

Fit To Be Tied

**Advanced
Macrame
Projects**

**Off Loom
Weaving**

**HANGING
CHAIR**

See page 3

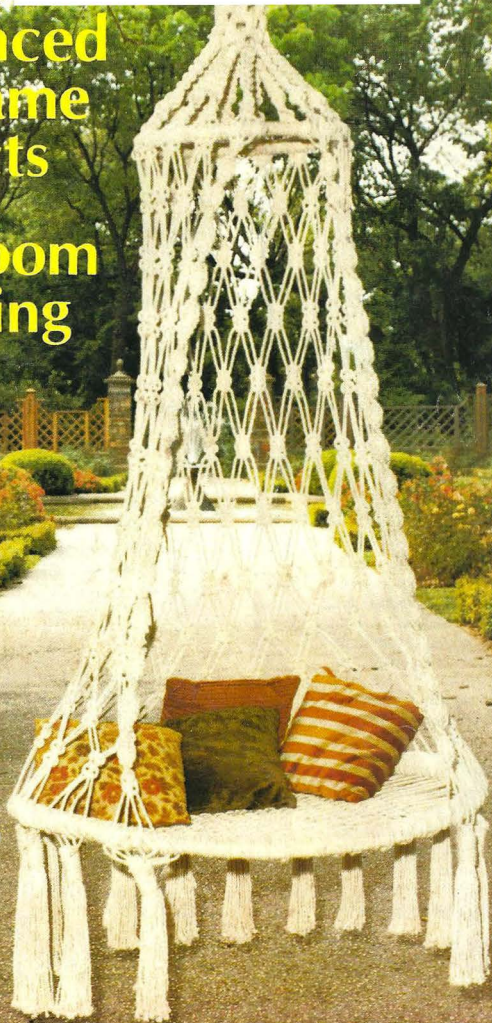

TABLE OF CONTENTS

- 1 HANGING CHAIR — Cover
(instructions page 3)
- 4 SWEETHEART — Variations #1,
#2, #3 (instructions page 9)
- 5 SUGAR & SPICE (instructions page 10)
JUST HAVING FUN (instructions page 11)
SAMY (instructions page 19)
- 6/7 BASIC KNOTS
- 8 FUZZY WAS HE? (instructions page 22)
TWIST A ROPE (instructions page 10)
OWL NECKLACES
SANDY OWL (instructions page 15)
- 17 HOOP A TOWEL (instructions page 18)
SAMPLER WALL HANGING
(instructions page 18)
DOWEL TOWEL (instructions page 16)
- 20 SAND & SEA (instructions page 16)
SALIDA DEL SOL (instructions page 14)
TURKISH DELIGHT (instructions page 14)
- 21 COLLAGE PAGE
EARTH-SEA AIR
BERRY PATCH
RINGS & STRINGS
LITTLE SPOTS (instructions page 11)
- 23 WEAVING TERMS, HINTS & BASIC WEAVE
- 24 CREATING A FORM — Back Cover
Butterfly (instructions page 12)
SIERRA — Back Cover Lamp
(instructions page 13)



Two weeks ago I couldn't say macrame now I am one.

All designs in this book are originals of Lyn Buerger and Boyd Bartley. Although instructions in this book have been tested the authors cannot accept responsibility for individual interpretations of knots, instructions and techniques. If you have a problem, be creative.

No portion of this book may be reproduced in any form without prior written consent of the publisher.

CORDS USED IN THIS BOOK: Lofted nylon, Tex-Twist (Ludlow polyester), polyolefin cable cord, Maxi-Cord, & misc. hand spun fibers in weavings. If you are unable to locate any materials please write: Dealer and distributor inquiries welcome.

Lyn-Arts, dba Forum Art Center

827 E. Park Row / #238 Forum Mall
Arlington, Texas 76101

SPECIAL THANKS TO

Publisher
FIT TO BE TIED

Editor
LYN BUERGER

Associate Editor/illustrator
BOYD BARTLEY

Photography
BLAUVELT STUDIO

Photography
NEIL MARTIN

Graphic Design
PATRICIA C. WILLIAMS

Caricature
BUDDY HICKERSON

Pottery
JOE DELWAIDE

Plants
BIT A GREEN

Editorial Consultant
HESTER BENDER

Encouragement
MY FRIENDS

*And a very special thanks
to my son, Jerry,
for putting up with me.*

HANGING CHAIR

see front cover

Finished Length 6'

Material needed:

600 yards approx.

(a) 28 at 15 yards (420)

(b) * 4 at 20 yards (80)

Plus enough to wrap hoops

*Put these cords through ring so that one end is 6 yards long and other end is 14 yards.

1 3" or 4" heavy duty metal ring

1 14" to 16" hoop (very strong)

1 hoop for bottom approx. 36" diameter. I used 2 oak hoops wrapped one inside the other for extra strength. (or substitute a solid plywood bottom, padded)

COMMENT: Be sure that knots are tight to avoid later settling.

Material used: 3/16" cotton rope, hard twist

Substitute: Tex-Twist

Fig. 1. ORDER OF CORDS IN CROWN KNOT and POSITION ON 1st HOOP

(a) Sets with 15 yard cords folded in half

(b) Sets with 20 yard cords folded 6/14 yards

Fig. 1

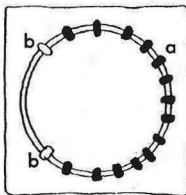

1. Put all cords through heavy ring (note order of sets relative to long cords.

2. Separate cords into sets of 8 cords (8 sets) with the (b) cords making one set. Crown knot 8" to 12".

3. Do any combination of square or half knots for approx. 12" using sets of 4 cords. (I did 8 square knots, 7 half knots, 3 square knots)

4. Double half hitch all cord onto 1st wrapped hoop. Be sure hoop is level and knots tight.

5. Begin knotting using alternating square knots per fig. 2. Approx. 6" between alternating.

NOTE: At point circled on fig. 2 let the two cords from alternating knots become filler cords in at least 2 half knots. Be sure each time to return cords to original position. Filler cords on (b) sennets are load bearing cords and must remain in proper position.

Fig. 2

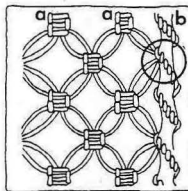

6. Macrame in alternating knots (I used double square knots) until desired length is obtained for chair seat position. Chair will settle some after finishing. Bottom of chair is finished with weaving pattern, using cords that you macramed with.

7. Double half hitch all cords onto bottom hoop leave opening for chair entry. Be sure that chair hangs somewhat level. Pull tight.

8. **Warping Seat:** Back cords are brought forward and double half hitched onto front of hoop, start center back. Pulled tight this will bow hoop into a very lovely functional oval. Return these cords to back and double half hitch next to their original position.

Fig. 3

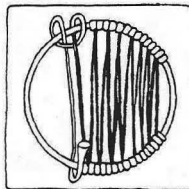

9. Side cords are carried across hoop using tabby weave through warp and double half hitched onto opposite side. Alternate from left to right side in weaving. Pull tight. Wrap cords into groups and tassel.

SWEETHEART #2 *See page 9*



SWEETHEART #1 *See page 9*



SWEETHEART #3 *See page 9*



SUGAR & SPICE

See page 10

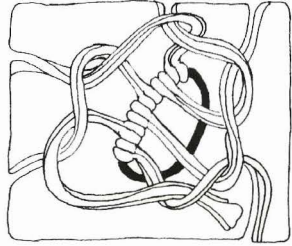

Crown knot with 6 sets of cords



JUST HAVING FUN See page 11



SAMY See page 19

BASIC KNOTS

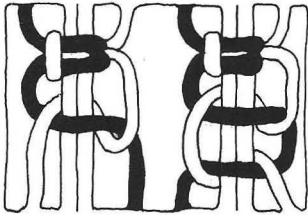

SQUARE KNOT

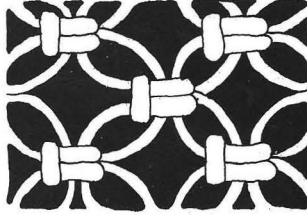

ALTERNATING SQUARE

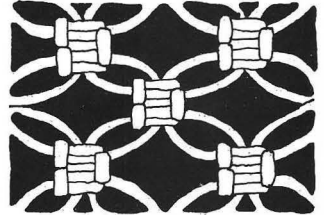

ALT. DOUBLE SQUARE

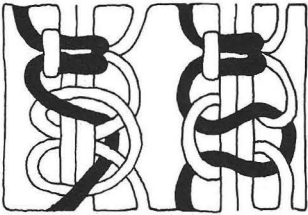

SQUARE KNOT SIMPLIFIED

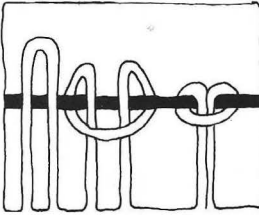

LARK'S HEAD

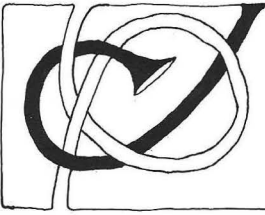

JOSEPHINE KNOT

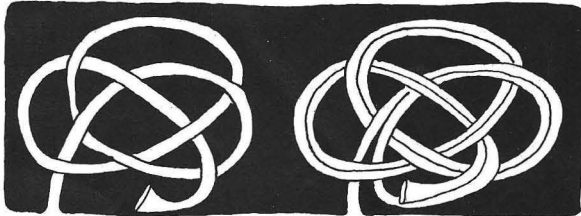
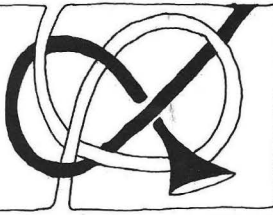

TURK'S HEAD

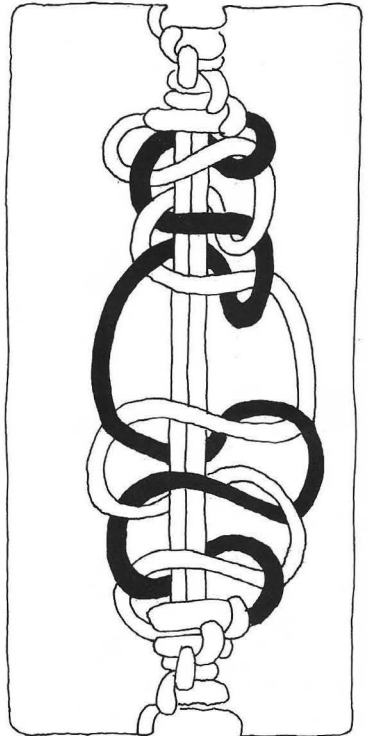

ALTERNATING TWIST

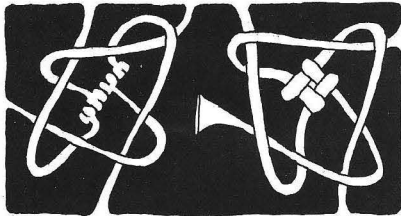

CROWN KNOT

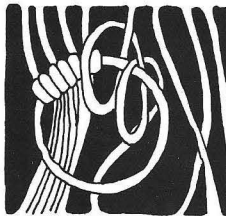

DOUBLE HALF HITCH ONTO RING

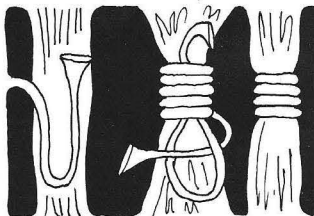
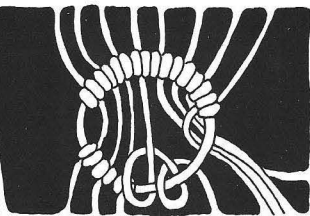

GATHERING CORD

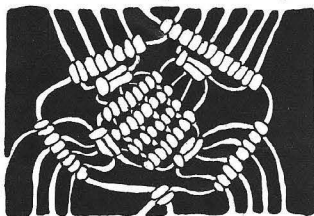

BERRY KNOT

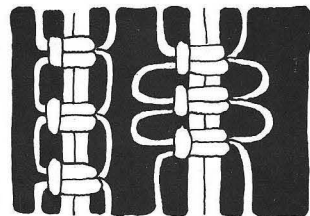

PICOT

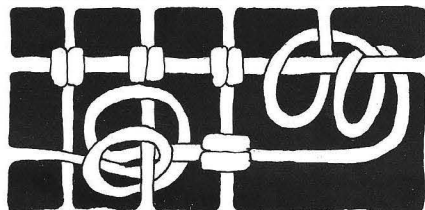

DOUBLE HALF HITCH VARIATIONS

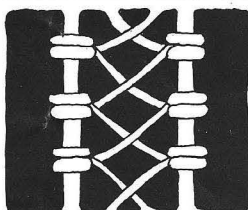

ALT. DOUBLE HALF HITCH

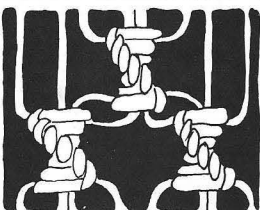

ALT. TWIST KNOT

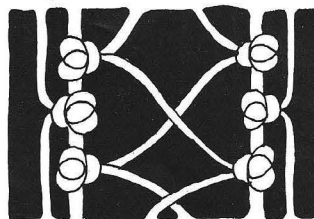

ALTERNATING LARK'S HEAD

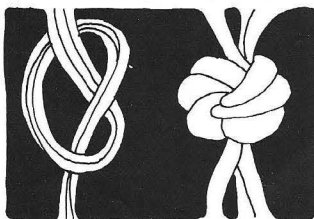

OVERHAND KNOT

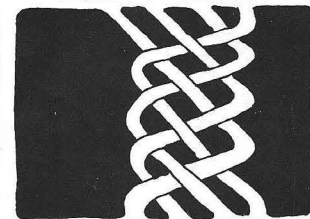

BRAID

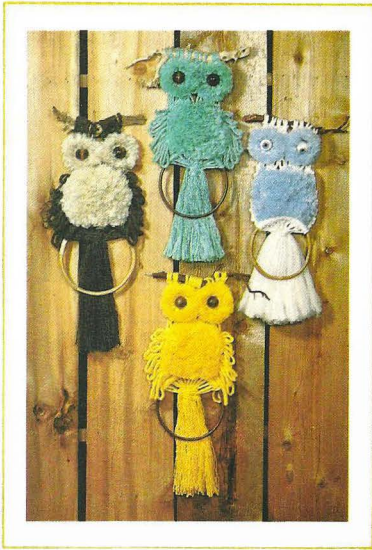

FUZZY WAS HE?

See page 22

OWL NECKLACES (below center)

Note: These macramés are small versions of larger owls shown here. See instructions for larger owls on pages 15 and 22. Cut cords 1 yard each using either waxed nylon, linen, cotton or the rattail cords. Owl will make-up in size depending on size cord used. The pictured samples shown on this page were made of waxed cotton and rattail.

Eyes: Can be beads inserted during macrame process or glass animal eyes added to finished macrame owl. Animal eyes come in many sizes to fit most any small owl you will macrame. See local craft shop.



TWIST A ROPE *See page 10*

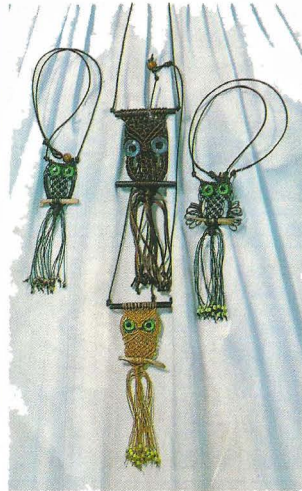

OWL NECKLACES *See above*

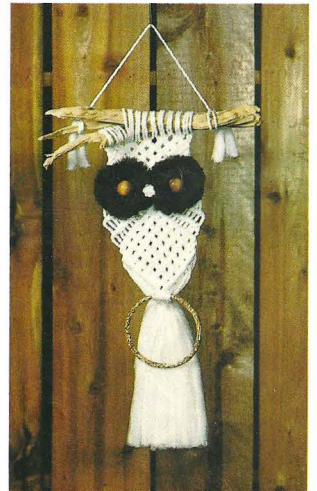

SANDY *See page 15*

SWEETHEART see page 4

COMMENT: As you can see this one basic pattern can be made a number of beautiful ways and lengths. Here are just three variations.

#1 12 cords 12 yards (144 yards)

#2 12 cords 12 yards (144 yards)

#3 12 cords 16 yards (192 yards)

Material used: 1/4" rope (lofted nylon, Maxi-cord, Tex-Twist, or 72/5 or 72/6 jute)

Supplies: 1 3 or 4" heavy duty metal ring for top
1 5" metal ring for bottom

#1 Instructions: Finished Length ring to table top 48", lofted nylon

1. Put all 12 cords through ring, fold in half. Separate into sets of 4 cords (6 sets) and crown knot for 6" to 8".

2. Do one button knot with each set of 4 cords immediately under crown knot. I find it easier to do if I use 2 cords from 2 adjacent sets, rather than using the sets of 4 directly out of the crown knot.

3. Alternate and do another row of button knots. Alternate and do 3rd row of button knots.

4. Under last row of alternating button knots, do 2 rows of alternating single square knots.

5. Drop to approximately 1/2 of distance to table top (15") and do alternating twist knots starting with center 4 cords of each set of 8 cords. (see illustration on knot page)

6. Double half hitch all cords to 5" metal ring down about 15" to 20".

7. Finish table bottom with either alternating square knots or another series of alternating button knots. This table is finished with alternating buttons. 1st row is 4 square knots, 2nd row is 6 square knots, 3rd row is 8 square knots, 4th row is 10 square knots.

#2 Instructions: Finished Length ring to table top 48", Tex-Twist

1. Put all 12 cords through ring, fold in half. Separate into sets of 4 cords (6 sets) and crown knot for 6" to 8".

2. Alternating button knots. 1st row 4 square knots, 2nd row 6 square knots, 3rd row 8 square knots, 4th row 10 square knots.

3. Working with sets of 8 cords, macrame alternating squares (4 square knots each sennet before you alternate) down to table top.

4. Double half hitch all cords onto 5" ring. Finish with alternating buttons each with 4 square knots.

#3 Instructions: Finished Length 70", lofted nylon

1. Put 12 cords 16 yards through ring folded in half. Separate into sets of 4 cords (6 sets) and crown knot 6" to 8".

2. Alternating button loops. 1st row has 4 square knots, 2nd row has 6 square knots, 3rd row has 8 square knots, 4th row has 10 square knots.

3. Working with three sennets of 8 cords macrame to table height (any combination of alternating square and twist knots. But remember that what you do on first sennet you will need to repeat again on the other two sennets.

4. Double half hitch all cords onto 5" metal ring. Bottom is alternating rows of button knots (4 square knots each).

5. Extra tassel on bottom I added to use up scrap cords.

HINTS

Rules for computing cord for your own design, based on folding the cords.

Alternating knots (simple design) = 4 to 6 times desired finished length

Alternating knots (complex design) = 6 to 8 times desired finished length

Straight knotting (simple & spaced)

Knitting cords = 6 to 8 times desired length

Filler cords = 3 times desired length

Straight knotting (complex)

Knitting cords = 8 to 10 times desired finished length

Filler cords = 4 to 6 times finished length

SUGAR & SPICE see page 5

Finished Length 65"

Material needed:

350 yards

(a) 8 at 20 yards (160) folded 6/14 yards

(b) 12 at 14 yards (168) folded in half

plus enough to wrap hoops

1 3" metal ring

2 6" metal rings

1 14" to 16" hoop wrapped

1 hoop just smaller than table top

(I used 24" glass and 22/23" hoop)

Material used: Lofted nylon

Substitutions: Tex-Twist (Ludlow polyester), 72/5 or 72/6 jute, or 1/4" rope

Fig. 1. ORDER OF CORDS IN CROWN KNOT AND POSITION ON 1st HOOP

(a) Sets with 20 yards cords folded 6/14 yards

(b) Sets with 14 yard cords folded in half

Fig.1

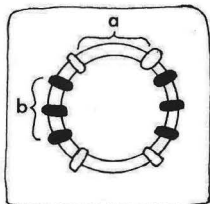

1. Put all cords through ring (note order of cords relative to sets of long cords) Separate into sets of 4 cords (10 sets) BE SURE THAT sets (a) and (b) are in proper order. Crown knot for 6" to 8".

2. Do twist knots with sets of 4 cord sennets for approx. 6" to 8". Double half hitch all cords to 6" metal ring. Be sure ring is level.

3. Double half hitch all cords to 1st wrapped hoop. Be sure hoop is level. Note spacing in fig. 1 above for groupings.

4. Begin knotting using alternating double square knots per fig. 2, leaving approx. 6" between alternating knots. The sennets with long cords (a) can be half knots or square knots.

NOTE: At point circled on fig. 2, let the two cords from alternating knots become filler cords in at least two half knots of (a). Be sure each time that you return cords to original positions.

Fig. 2.

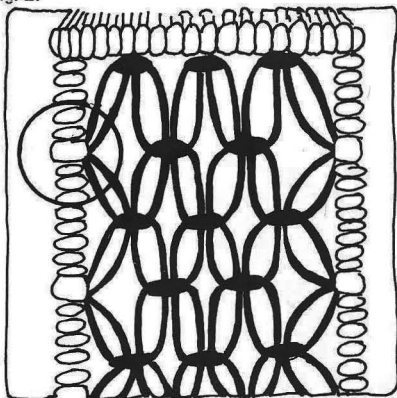

5. Continue until desired length is knotted. Be sure that knotting on both sides of table match in length and spacing or table will not be level.

6. Table can be finished in a number of ways. Use your imagination. We double half hitched onto the wrapped hoop and tasseled.

TWIST A ROPE see page 8

Necklaces, Bracelets, Belts, Etc.

Cut cords just over twice as long as you want finished rope. The principal is the same for any application and the following is instruction for the necklace on page 8. (finished length approx 15")

1. Put 1 yard lengths together of any combination of small macrame cord. (I used rattail, 2 dark green and 1 light green). Twist cords tightly together, but not to point, they buckle.

2. Don't let go of the ends, keep twisted taut and fold in half. Very carefully let go of the folded end. The cord will twist into a beautiful rope mixing all the colors that you have used.

3. Tape the ends and trim leaving just enough tape to hold until you attach fastener. Glue bell cap and attach fastener.

4. Wear plain or add large hole beads, or add the latest fashion — silk flowers. Now make skinny ones, fat ones, long ones, mix and match . . .

JUST HAVING FUN

see page 5

Finished Length 75"

Material needed:

208 yards: 16 cords 13 yards

1 4" metal ring

2 6" metal rings

Table top 16" to 20"

Material used: 1/4" cotton rope

Substitutions: Tex-Twist, polyolefin cable cord, 72/5 jute

1. Put 16 cords through ring, fold in half. Separate into sets of 4 cords (8) sets, and crown knot 6" to 8".

2. Using four cords per sennet, knot 2 sennets or twist knots and 2 sennets of square knots for approx. 8" to 10". (8 sennets in all)

3. Double half hitch all 32 cords to 6" ring.

4. Do 3 rows of alternating double square knots and double half hitch all cords to 6" ring.

5. Do 2 square knots on each set of 4 cords.

6. Alternate and do twist sennets (alternate each sennet so that one is left over twist and other is right over twist). After 6 half knots on left over twist sennets, do right over twists. On right over twist sennets, reverse and do left over twists. (One twist sennets turn inward toward the other, 6 knots per twist)

7. Do 2 rows alternating square knots.

8. Do 1 square knot under every other set. This starts center of each sennet of 8 cords (4 sets of 8 cords).

9. Double half hitch outside to inside, diagonal creating a "V".

10. Do 1 square knot in center of 8 cords at base of "V" using 4 cords.

11. Double half hitch from center out, diagonal, using filler cords of square knot for filler in DHH.

12. Do 3 rows of alternating square knots.

13. Double half hitch, diagonal, outside to center.

14. Do 2 rows alternating square knots.

15. Twist sennets using four cords each (6 left over twists, reverse and do 6 right over knots)

16. Do 3 rows alternating double square knots.

17. Repeat twist sennets of step 15.

18. Repeat steps 11 through 13.

19. Drop down about 8" from middle of last "V" and do 2 sennets of 3 square knots. Alternate and do 2 more rows of 3 square knots.

20. Double half hitch all cords to 6" ring. Add short cords to fill ring.

LITTLE SPOTS see page 21

1. Get an idea for the overall flow of your design. Do some pencil drawings. Then decide how best to interpret in fibers.

2. Shown here are three small designs using macrame knots and weaving. These designs are basically the same start with different executions.

3. The fun starts when you get into selecting color and texture. Be sure to go through your scrap barrel.

4. After you get started, listen to your design. It will tell you what it wants to do.

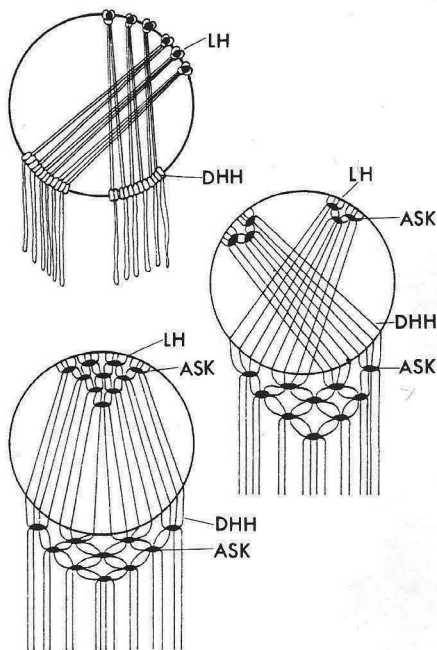

CREATING A FORM

see back cover

Butterfly

This is not a pattern

Finished Size: approx. 36" x 48"

Material used:

- 1-30" oak hoop
- 126 yards lofted nylon (21 at 6 yards)
- 1-6" metal ring (top wing)
- 1-4" metal ring (bottom wing)

Weaving fibers: polyolefin cable cord, and misc. hand-spun cords.

1. Pick a form to stimulate your imagination. A customer picked mine, because he wanted to give a gift to a butterfly nut.
2. Do some simplified drawings, keep in mind that you will be interpreting these lines in fibers.
3. With the butterfly I started by mounting cords, folded in half, with lark's head knots to top of hoop. I added cords as I needed them. I eventually ended up with 19 cords each 6 yards long.
4. I began knotting by starting with cord at point (a) on fig. 1. to form the top of the back wing.
5. Then I did the front wing using cord at point (b).
6. Add rings in design for spots on butterfly before you do the bottom of the wing.
7. Experiment by pulling different tension on the cords to create the form desired. You may, also, have to make use of single and triple half hitches in addition to double half hitches.
8. I found that for bottom wing I needed to add additional cords instead of using existing cords in pattern. (c)
9. Curved effect on bottom of bottom wing was gotten by adjusting tension on the cords.
10. Head and body of butterfly was made by adding new cords from base of wing out to hoop with lark's head knot. Realistic effect will be added later in hand-spun fibers.
11. Now get creative in tasseling and weaving.

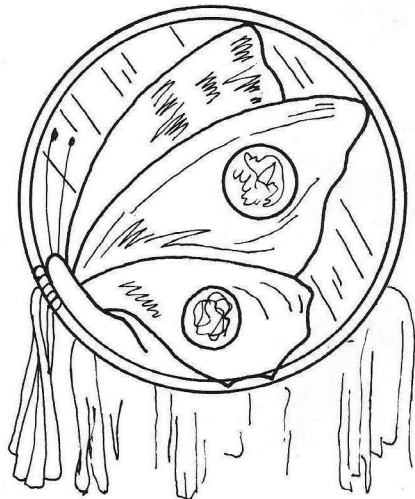
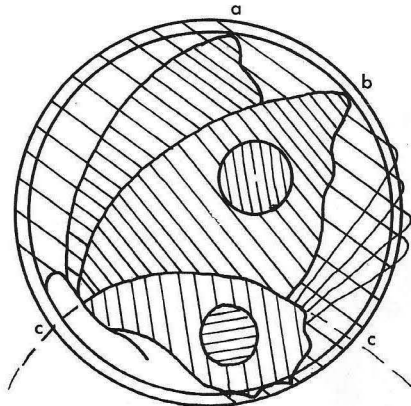

LOTS OF LUCK

SIERRA LAMP see back cover

Finished Length Approx. 6'

Material needed:

- 324 yards
- 16 at 13 yards (208)
- 32 at 3 yards (96)
- 20 yards to cover lamp electrical cord
- 1-3" metal ring
- 3-6" metal rings (1 with lamp hook-up if possible)
- 1-12" metal ring
- 1-15" metal ring
- 1-8' electrical cord
- 1-8" to 10" rib pot
- 1-ceramic light fixture

Material used: 3/16" cotton rope, hard twist

Substitution: 5/32 jute, polyolefin cable cord

1. Put 16 (13 yard) cords through ring, folded in center. Separate into sets of 4 cords (8 sets) and crown knot for approx. 24".

2. Double half hitch all cords onto 1st 6" ring. To make pattern more interesting I crossed sets of 4 per fig. 1, below. Be sure ring is level.

Fig. 1.

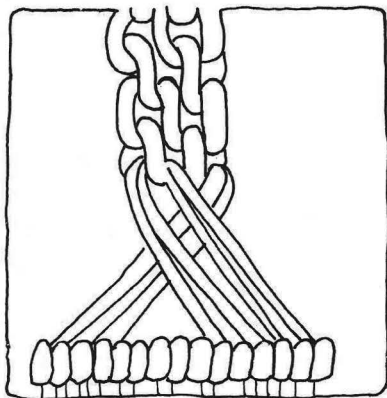

3. Do alternating square knots (or alternating double square knots) using sets of 4 cords, for approx. 12".

4. Double half hitch all cords into second 6" ring. Be sure ring is level.

5. Do 2 rows (6 half knots each) alternating half-square knots (twist)

6. Double half hitch onto 12" ring. Existing cords will not fill the 12" ring. Add 4 of the 3 yard cords between the sets of 4 cords. This will give you 96 working cords. If you have to add more than 32 cords to fill the 12" ring be sure to add so that you will have sets of 4 cords.

7. Now do either alternating square knots or alternating double square knots. (double square knots give a more open look) Do alternating knots for about 12".

8. Double half hitch all cords onto the 15" ring. If ring is not filled lark's head on short cords to fill ring (this can be done last using scrap cords). Trim and tassel all short cords, be careful not to cut any of the original 13 yard cords at this time.

9. Using the original long cords continue knotting down about 18" to 24" using either square or twist knots. Using 2 cords from each sennet drop down about 6" and do josephine knot

10. Double half hitch all 32 cords onto last 6" metal ring so that each set of 2 cross the next set of 2. Be sure ring is level. Trim and tassel.

11. **Lamp:** I attach lamp fixture by adding cords with lark's head at second 6" ring (inside) to secure pot and ceramic fixture. If you can find the 6" ring with lamp fixture hook-up attached use it instead.

12. **Cord Cover:** Cut 20 yards of matching cord. Do square and twist knots using lamp cord as filler and 20 yard cord folded in half as knotting cord.

HINT

If prescribed number of double half hitches does not cover ring, either add a half hitch or add cord depending upon which would best fit your design. Or use a decorative ring and let it show (metal, bamboo or rattan).

TURKISH DELIGHT

see page 20

Finished Length 48"

Material needed:

158 yards

12 at 12 yards (144)

1 at 4 yards for turk's head knot

40 at 9" for rya fluff

1-3" heavy duty metal ring

3-4" metal rings (2 top, 1 bottom)

1-14" to 18" glass

Material used: Lofted nylon

Substitutions: Tex-Twist, polyolefin cable cord, 72/5 or 72/6 jute

1. Put all 12 cords through 3" metal ring, fold in center. Separate into sets of 4 cords (6 sets) and crown knot 6" to 8".
2. Add turk's head knot with separate cord. Start knot on a flat surface, slide into position on hanger, adjust knot to fit snug, glue and cut ends. This is not necessary to function of table, only gives meaning to title. Omit if desired.
3. Double half hitch onto 1st 4" metal ring.
4. Drop about 4" and double half hitch onto 2nd 4" metal ring. The space between rings is for rya shag. Be sure rings are level and parallel.
5. Do 3 rows of alternating square knots under last ring using all 24 cords in sets of 4 cords.
6. Separate cords into sets of 8 cords (3 sets). Using 2 cords on outside and 4 cords in center of the 8, do half knot sennets for approx. 18" to 20" or until sennets make 3 complete turns.
7. Separate cords into sets of 4 cords. Do half knots until knots make 3 complete turns (approx. 18 half knots).
8. Rejoin eight cords by repeating step #6.
9. Separate cords again into sets of 4 cords and do half knot twist sennets. Knot until you reach desired length of table.
10. At level you want table to hang, switch from half knots to square knots for last 4" to 6".
11. Double half hitch onto last 4" ring. Tassel. If bottom ring is not filled with cord, add additional cords to ring with lark's head knot.
12. **Rya Shag:** Add 9" pieces with rya shag weave between top 4" rings. See weave page 23. Fluff can also be added with lark's head knots.

SALIDA DEL SOL (sunrise)

see page 20

Finished Length Approx. 30"

Material needed:

224 yards

12 at 6 yards (72)

12 at 5 yards (60)

24 at 3 yards (72)

20 yards to cover electrical cord

1-3" to 4" metal ring

1-6" metal ring (with lamp hook-up if possible)

1-10" metal ring

1-15" metal ring

1 ceramic lamp fixture set

1 8' electrical cord

Material used: Tex-Twist (Ludlow polyester)

Substitution: polyolefin cable cord, 72/4 jute

1. Put 6 yard cords through 3" ring, fold in half. Separate into sets of 4 cords (6 sets) and crown knot for 4" to 5".
2. Using sets of 4 cords, do 4 square knots. Mount all cords onto 6" ring with double half hitches. Be sure ring is level.
3. Add 5 yard cords to ring with lark's head knot (2 cords between each set of 4). You now have 48 working cords.
4. Do alternating twist knots, using sets of 4 cords. Do two rows, 7 knots each.
5. Double half hitch all cords onto 10" ring. Add 24 (3 yard) cords to this ring. (2 cords between the sets of four cords. You now have 96 working cords.
6. Do several rows of double alternating square knots. Leave about 1/2" between alternating rows.
7. Double half hitch all cords to last ring. Be sure that rings are level and parallel. If ring is not filled add additional short cords between other cords with lark's head knot. Tassel and trim.
8. **Electrical Cord:** Fold 20 yard cords in half, using extension cord as filler do either square knots or half knots to cover.
9. **Lamp Set:** Install fixture inside lamp after finished. Either attach with strong wire down through crown knot or use a 6" ring that has a lamp hook-up.

SANDY OWL see page 8

Finished Length 36"

Material used:

76 yards body: 12 at 6 yards
4 yards eyes: 24 at 6"
1-15" stick
2-2" metal rings (1-1/2" will do)
2-beads for eyes (just smaller than metal rings above)
1-7" to 10" hoop or a stick for perch

Material used: Tex-Twist (Ludlow polyester)

Substitution: Lofted nylon, 72/5 or 72/6 jute

1. Mount all 12 cords onto stick or branch with lark's head knot (cords folded in half)
2. Do no knots with outside two cords on both sides. Do alternating square knots using sets of 4 cords, see fig. 1. forming a "V" shape by dropping 2 outside cords each row.
3. Do 3 rows of double half hitches on both sides, from outside to center, diagonally. Double half hitch each row to each other in the center.
4. Do one button knot using four center cords with 4 square knots to form a beak.
5. Starting with center cords under button knot do row of double half hitches from center to outside at diagonal. Repeat for other side. Do 3 rows of diagonal double half hitches from center to outside, see fig. 1. Taper the spacing to get the wing effect.
6. Tummy is formed by doing single alternating square knots. Start with center 4 cords.
7. After diamond pattern is complete do one last row of diagonal double half hitches toward center from outside.
8. Double half hitch onto another stick for perch, or hoop for towel holder. Use 4 center cords only.
9. Finish by doing one or two square knots around all cords using two outside cords on either side as knotting cords. Trim and tassel.
10. **Eyes:** lark's head short cords onto metal ring, separate ply and brush to get fuzzy look. (Ludlow polyester/ Tex-Twist is the only cords that we have found that will work easily. Attach bead and ring to owl using small wire or waxed macrame thread.

Fig. 1

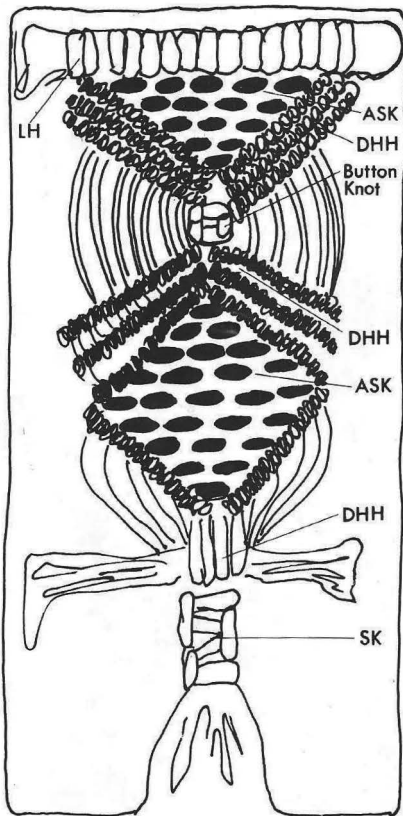

HINT

Practice the simplified square knot in the knotting section. It is quite fast after you get the hang of it.

SAND & SEA see page 20

Finished Length 6'

Material needed:

226 yards: 8 at 15 yards (120)

6 at 1 yard

8 at 10 yards (80)

50 at 12" for rya shag

1-3" metal ring for top

2-5" metal rings

Shells added to individual desires.

Material used: 1/4" cotton rope

Substitutions: Tex-Twist, lofted nylon or 72/6 jute

1. Put 8 (15 yard) cords through heavy duty ring, folded in half. Separate into sets of 4 cords each (4 sets). Crown knot for 6" to 8".

2. Mount all cords onto 5" ring with double half hitches.

3. Add 1 yard cords in spaces between sets of 4 (2 between each set) with lark's head knot.

4. Double half hitch all cords onto another 5" metal ring leaving about 3" between rings. Rings should be parallel and horizontal. This space is for rya shag.

5. Half knot twist on sennets of the long cords. approx. 8" to 12". Short 1 yard cords at trimmed and tasseled and shells added to them.

6. Alternate, taking 2 cords from each sennet to form new sennet. Drop down about 6" and do half knot twist for about 12".

7. Add 2 ten yard cords folded in half (one at the time) at this point on each sennet with double half hitches. Each of the 4 sennets now has 8 working cords. See fig. on page 20

8. Do alternating square knots starting with center 4 cords. Do 6 rows of alternating square knots.

9. Do 1 row of double half hitches from outside to center, diagonally forming a "V" shape.

10. Separate each sennet of 8 cords into sennets of 4 cords. Do half knot twist to desired length of table. I alternated the sennets with left over knots on one sennet and right over knots on next sennet.

11. Mount each cord of each sennet onto wrapped wood hoop with double half hitches reversed so that cords mount the hoop from the outside edge. This lets glass table top lay flat on hoop and not directly on sennet cords. Tassel and trim.

12. **Rya Shag:** 12" pieces are added between 5" rings at top with rya shag weave, see page 23. A lark's head knot can also be used.

Shells: Add shells with small wire or waxed thread to match cord.

DOWEL TOWEL see page 17

Finished Length Approx. 36"

Material needed:

112 yards

16 at 7 yards

7 at 1 yard

3-36" dowel rods 3/4" or 1" diameter

2-hoops 5" to 8"

1-set drapery rod end nobs

Material used: Maxi-Cord

Substitution: Tex-Twist, polyolefin cable cord, or 72/5 or 72/6 jute

1. Mount 16 cords (folded in half) onto 1st dowel rod with lark's head knots, 8 cords at either end, see picture page 16.

2. Do square knot design per fig. 1. Repeat twice.

3. Mount all cords to next dowel rod with double half hitches. Be sure dowel is parallel and horizontal.

4. Repeat square knot pattern per fig. 1.

Fig. 1

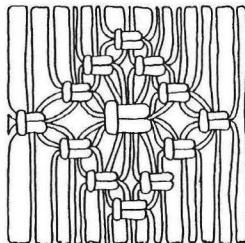

5. Double half hitch all cords to next dowel. Be sure dowel is parallel and horizontal. Tassel and trim.

6. **Center Section:** If you have any long scrap use 1 yard pieces to do alternating square knot pattern and attach hoops at desired length with double half hitches.

HOOP A TOWEL See page 18

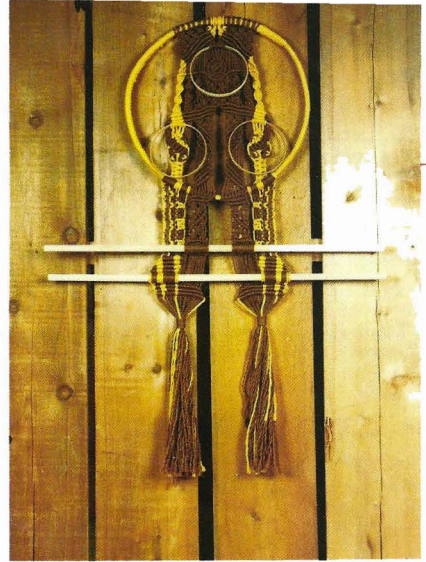
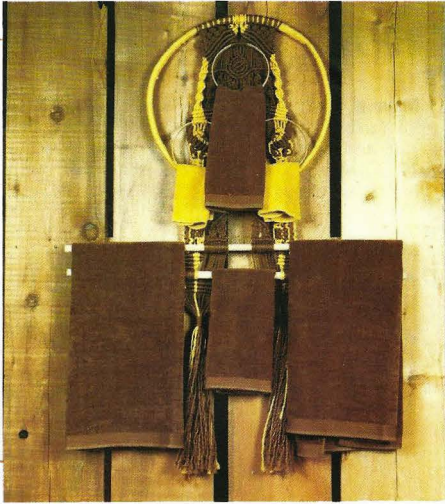

SAMPLER WALL HANGING See page 18

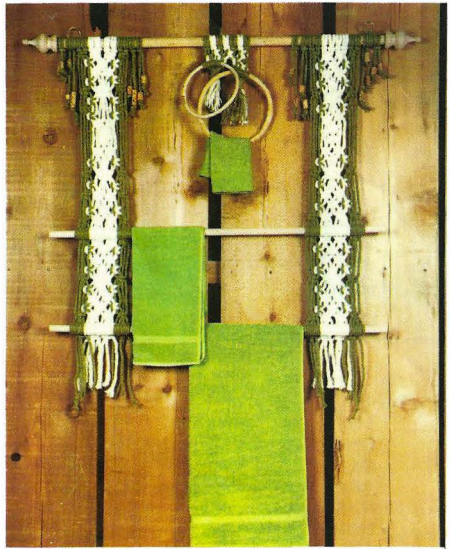

DOWEL TOWEL See page 16

SAMPLER HANGING

see page 17

Finished Dimensions: 24" x 36"

Material used:

- 116 yards 7/26 jute or equivalent
- 18 cords 6 yards (folded in half)
- 3 cords 2 yards (added at DHH)
- 2 cords 1 yard (to wrap tassels)

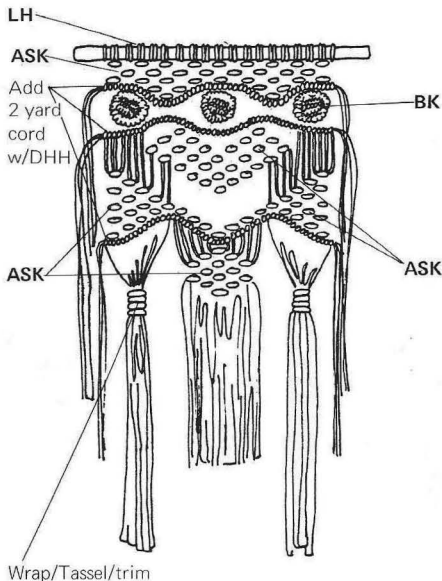

KEY

- LH** Lark's Head Knot
- DHH** Double Half Hitch Knot
- SK** Square Knot
- ASK** Alternating Square Knot
- HKS** Half Knot Spiral (or Sennet)
- DDHH** Diagonal Double Half Hitch
- BK** Berry Knot

HOOP A TOWEL

see page 17

Material used: polyolefin, or Macra Cord cable cord
96 Yards

- 16 at 6 yards
- 1-20" oak hoop
- 3-6" to 8" hoops

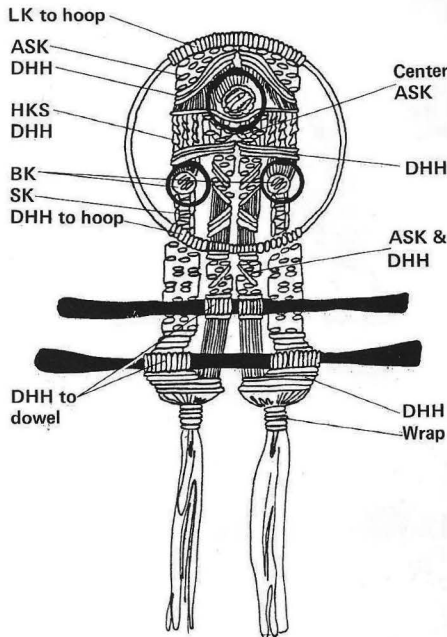

HINT

If you have trouble finding the size pot you want, remember there are potters around who will make you the size you want. If you live in a city that has a college a starving potter is usually easy to find.

Finished Length 6'

Material needed:

300 yards

12 at 15 yards(a)

12 at 10 yards(b)

1-3" or 4" heavy metal ring

2-6" metal rings (1 top, 1 bottom)

1-8" metal ring (top, under 6" ring)

1-4" metal ring (top under pot)

12 large beads (I used spun porcelain)

Material used: Lofted nylon

Substitutions: Tex-Twist, any 1/4" rope, 72/5 or 72/6 jute

1. Put 12 (15 yard) cords through heavy metal ring, (folded in half). Separate into sets of 4 cords (6 sets). Crown knot to hearts desire (6" to 8").

2. Do either square or half square knots with each set of 4 cords from crown knot for about 6".

3. Double half hitch all cords to 1st 6" metal ring. Be sure that ring is level.

4. The 6" ring is not covered. Add 12 (10 yard) folded in half cords to 6" ring with lark's head knots. Add 4 cords between other cords per fig. 1.

5. Using each set of 4 cords (12 sets) do 1 button knot (4 squares) all the way around the ring. Be sure

that you put 1 square knot under each button knot to hold it in place.

6. Add one bead to each sennet under button knot. Square knot under each bead.

7. Double half hitch all cords onto 8" ring immediately under square knot. Be sure rings are parallel.

8. Start sennets for pot with short cords using alternating double square knots. Knot about 8" to 12" before splitting off into separate sennets. Knot for about 12" in separate sennets with either square knots or half knot twist. Knot down until you have reached a comfortable length for pot you intend to use.

9. double half hitch 24 cords that make the pot holder onto the 4" metal ring. Tassel and trim.

10. Start sennets for table with long cords using alternating twist knots. Knot down to desired length for table top. When you reach desired length of table, switch to alternating square knots 6" to 12" depending on diameter of glass top you intend to use.

11. Double half hitch all cords from long sennets to last 6" ring. Use scrap cord to fill bottom ring and make tassel full. Trim and tassel.

Fig.1

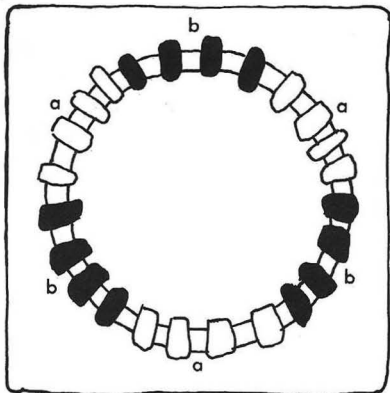

HINTS

Half knot twists — keep knots horizontal and even for neat twists. Left over knots twist in one direction, right over knots twist in other direction.

Raveling — measure, tape cord with celophane or masking tape and cut through tape. Both ends automatically sealed.

Wood rings are interesting and beautiful, but not where they will have to bear tension. They will break.

Measuring cord. — Measure one cord and use that cord to measure remainder of required cords. Don't let them slip as you go. Note: Lofted nylon does expand in diameter and shrink in length when it comes off the bolt. Allow for this condition when you cut your cords.



SAND & SEA see page 16

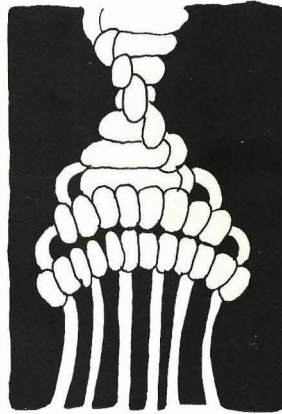

SALIDA DEL SOL See page 14



TURKISH DELIGHT See page 14



RINGS AND STRINGS



EARTH-SEA-AIR

BERRY PATCH

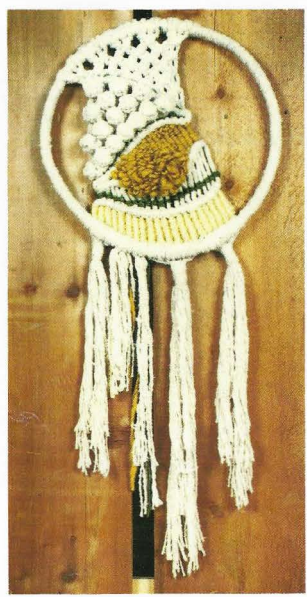

COLLAGE PAGE

There are no instructions for these off loom designs, except for brief information of Little Spots. Just wanted to present extra design ideas to help you get started.

LITTLE SPOTS *See page 11*

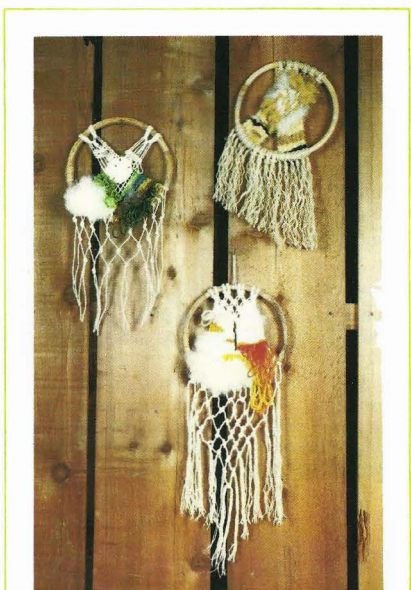

FUZZY WAS HE?

see page 8

Finished Length Approximately 24"

Material needed:

- 32 yards (body foundation)
 - 4 at 3 yards (12) (a)
 - 4 at 5 yards (20) (b)
- 25 yards (body fluff)
 - cut into 7" pieces
- 4 yards (eye fluff)
- 1 15" stick for top
- 2-2" metal rings for eyes
- 2 beads just small than rings for eyes
- 1 6" to 8" hoop for perch

COMMENT: The glass eyes used in some of our owls are available at most craft shops and they are glued in place in the hole of the bead.

Material Used:

Body foundation: Maxi-Cord, Lofted Nylon

Body & Eye Fluff: Tex-Twist (Ludlow polyester)

1. Lark's head all cords to stick (folded in half) in order per fig. 1., 2 longs, 4 shorts, 2 longs.
2. Do alternating rows of single square knots (6 rows, with slight spacing).
3. With Cord (b) on each side do 6 or 7 square knots with picots made with filler cords adjusted to simulate feathers, see fig. 1.
4. Do no knots with center 8 cords. These cords are to support tummy fluff.
5. Double half hitch all cords to a ring or perch.
6. Add fluff for tummy with 7" pieces by lark's head knot. Start lark's head additions just above ring and working up. Pack cords down into place.
7. Brush and trim fluff.

COMMENT: Tummy area will need some special care. I usually use some glue and small wire on the back side to help stabilize the whole tummy area.

8. **Eyes:** Add 6" fluff cords to rings with lark's head knot. Separate ply and brush. Secure ring with fluff to owl body with small wire or waxed thread. Bead eyes can either be wired in place or glued. Be careful that wire and glue do not show.

Fig. 1

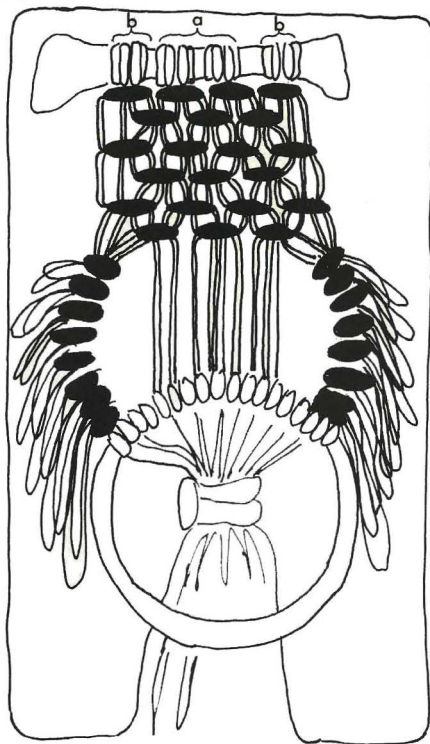

HINT

This hint takes a little practice to master, but is well worth the effort in doing a lot of double half hitches. Instead of looping the knotting cords over the filler cords one at a time, study the loops that the knotting cords make and practice making the loops with the knotting cords and then put the filler cord through. With practice you can do a whole row of DHH at one time.

WEAVING, TERMS, HINTS, & BASIC WEAVE

BEATER — tool which can be used to push weft down into place.

BUBBLING — weft is passed loosely through warp, into a slant, arch, bubble rather than straight (see fig.)

WARP — series of cords sometimes taut and vertical (not always though) through which the weft is passed to create a woven design. Warp cords should be strong enough that they won't break or stretch excessively. Be sure, also, they are rot resistant or at least have a long life because the warp is the backbone of your woven material.

WEFT — the cords or yarns used to weave across the warp. The weft yarns need not cover the warp completely. Keep design in mind.

YARN — Continuous length of cord, filament for weaving. There is an endless supply of weaving materials. Some are readily available for purchase and many you can produce yourself (ie. wood; fibers; hair of camel, goat, llama, rabbit; silk; cotton; linen; ramie; jute; hemp; rafia; reeds; slats; wood

strips; bamboo; fiberglass; metallic yarns; rayon; acetate; acrylics; saran; nylon; orlon; polyester . . .). As you can see the list goes on. Even strips of sewing material from your last sewing project and strips or twists or newspaper, but NOT THIS BOOK — PLEASE!!

1. Decide on an idea you want to illustrate or interpret. Do some pencil sketching and a lot of thinking.
2. Spacing of warp and weft will control, weight, feel, execution of design, etc.
3. Consider material for, color dynamics, texture, interest, contrast, and unity.
4. Complimentary colors used next to each other vibrate, mixed together they tend to become gray.
5. Neutral tones blend opposing hues nicely, but remember even neutrals have undertones that come out when added to another color. Put your materials together before you decide.
6. Your imagination and creativity are there, all you have to do is look for them.

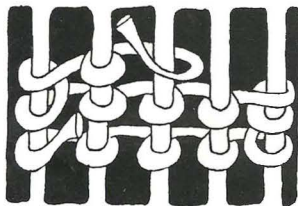

EGYPTIAN

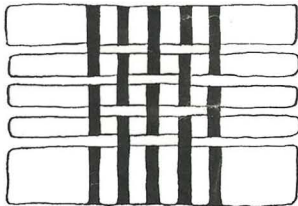

TABBY

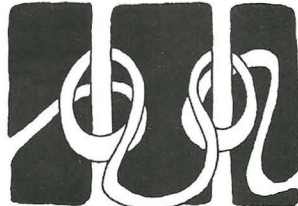

RYA

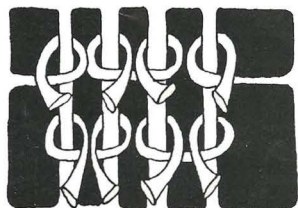

RYA SHAG



BUBBLING



SOMAK



SIERRA LAMP

See page 13



BUTTERFLY

See page 12

LYN ARTS / FORUM ART CENTER
ARLINGTON, TEXAS