

WOODHEAD PUBLISHING INDIA IN TEXTILES

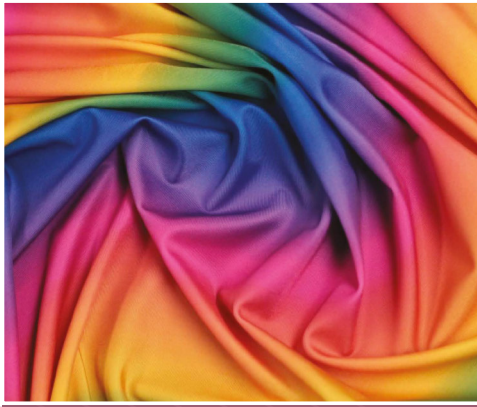

**Encyclopaedic Dictionary
of Textile Terms
Volume IV**

Mathews Kolanjikombil

WPI

Encyclopaedic Dictionary of Textile Terms

Encyclopaedic Dictionary of Textile Terms

Volume IV

Mathews Kolanjikombil

Senior Textile Processing Technologist

WOODHEAD PUBLISHING INDIA PVT LTD

New Delhi

Published by Woodhead Publishing India Pvt. Ltd.
Woodhead Publishing India Pvt. Ltd.,
303, Vardaan House, 7/28, Ansari Road,
Daryaganj, New Delhi - 110002, India
www.woodheadpublishingindia.com

First published 2018, Woodhead Publishing India Pvt. Ltd.
© Woodhead Publishing India Pvt. Ltd., 2018

This book contains information obtained from authentic and highly regarded sources. Reprinted material is quoted with permission. Reasonable efforts have been made to publish reliable data and information, but the authors and the publishers cannot assume responsibility for the validity of all materials. Neither the authors nor the publishers, nor anyone else associated with this publication, shall be liable for any loss, damage or liability directly or indirectly caused or alleged to be caused by this book.

Neither this book nor any part may be reproduced or transmitted in any form or by any means, electronic or mechanical, including photocopying, microfilming and recording, or by any information storage or retrieval system, without permission in writing from Woodhead Publishing India Pvt. Ltd. The consent of Woodhead Publishing India Pvt. Ltd. does not extend to copying for general distribution, for promotion, for creating new works, or for resale. Specific permission must be obtained in writing from Woodhead Publishing India Pvt. Ltd. for such copying.

Trademark notice: Product or corporate names may be trademarks or registered trademarks, and are used only for identification and explanation, without intent to infringe.

Woodhead Publishing India Pvt. Ltd. WebPDF e-ISBN: 978-0-429-89327-8

Typeset by Bhumi Graphics, New Delhi

Contents

Preface *vii*

Volume I

1. A	1
2. B	99
3. C	222

Volume II

4. D	409
5. E	511
6. F	552
7. G	659
8. H	704
9. I	761
10. J	794

Volume III

11. K	811
12. L	834
13. M	889

14. N	975
15. O	1006
16. P	1034
17. Q	1160
18. R	1165

Volume IV

19. S	1227
20. T	1405
21. U	1494
22. V	1507
23. W	1532
24. X	1586
25. Y	1588
26. Z	1605

Preface

It has been told the first thing that a business man should know, is—the little things of his business. This book is meant for textile personae, be it a textile student, textile chemist, a spinner, a weaver, garment maker or a merchandiser who may be an expert in his/her field but he/she may come across many terms in his/her day to day business which he/she is not familiar with but is related to his/her field which he/she should know, but nine times out of ten does not know. He/She may not have an expert in that field of that term near him/her to clear his doubt about that term. This book comes handy in such circumstances.

There is nothing scholarly in this book, but is a compilation of short easy understandable meanings of the textile terms enough to help the referrer to understand the term. I have come across dictionaries which gives the meaning of the textile terms in one sentence. But it may not be sufficient to give a full idea about it. But this book is a little different. The meaning of the terms is explained in a concise manner even with the help of diagrams or photos, wherever necessary, which is enough to clear his/her doubts. These terms and meanings have been collected right from my college days and throughout my career. I believe it is not complete, but, such as it is, the compilation is reliable. There are further terms which are being collected by the author which will be added in the next edition, probably. The author believes that he has produced a book which may be profitably consulted by all who are either interested or practically engaged in textile trade.

It has to be specially mentioned that students can use the present book as a reference guide for his/her immediate needs without going to many textbooks. For detailed study of any terms he/she can further refer to books specialized in that field. I may not suggest this book for a research student. The author has also tried to explain the construction of many fabrics new or old for general knowledge.

Hope this book will be greatly accepted by textile personnel. Any suggestions or corrections are welcome, which will be included in the next editions.

Mathews Kolanjikombil

Senior Textile Processing Technologist

Bangalore

Dedication

*This book is dedicated
to my Father (Thomas
Abraham) and my
Mother (Thankamma
Abraham) who solely
made me what I am
today.*

S

S Twist: See **Direction of twist**.

SA 8000: Social standards in textiles and clothing by Social Accountability International.

S-Finish: A term originally applied to the partial surface saponification. A term originally applied to the partial surface saponification of cellulose ester fibres (acetate and triacetate) by alkaline hydrolysis to reduce static charge and improve fabric handle. Alkali treatment of polyester. Nowadays the term has also been adopted for an analogous treatment of polyester fibres in which a controlled partial saponification with alkali (NaOH) is carried out to achieve a silk-like lustre and handle, reduce the buildup of static charges and improve anti-soil properties.

Sable: French for mottled effect.

Sable: A dark brown luxury fur which is very hard wearing.

Sabretache: A leather pocket hung from the left side of the sword hilt; a popinjay ornament.

Sabrina: Applique needlework, the leaves and petals of flowers made of coloured material edged with button hole stitches.

SABS: South African Bureau of Standards

Sacharilla Mull: A very delicate bleached cotton muslin, made of fine yarn with a low construction. It is given a very soft finish. Used for veils and turbans by the Moslems.

Sack: A business coat with pockets, made single and double breasted; a loose Chesterfield overcoat.

Sack Cloth: Very coarse cotton or jute fabric, woven plain, used for bags.

Sacking: See **Bagging and Heavy goods**. (1) Heavy, three or four end twill jute or hemp cloth of double warp and single filling, used for cement and ore bags; (2) Solid coloured flannels for kimonos.

SAD: SAD is a measure for soil pick up which is obtained by reflection measurement.

$$\text{SAD} = \log (\text{R-unsoiled}/\text{R-soiled})$$

Where

R = Reflection according to wavelength.

Saddening: Same as after treating.

Saddlecloth: In Arizona and Mexico masses of aloe fibre spread out in regular thickness and tacked to keep them in place. It is not woven.

Sadin: In the Bible means linen cloth.

Sadowa: Woollen dress goods with the nap being raised in circles, dots, squares, etc.

Safety Data Sheets: The ETAD (Ecological and Toxicological Association of the Dyestuffs Manufacturing Industry) has been issuing safety data sheets to affiliated dyestuff manufacturers since 1974 in order to support these efforts to protect environment and to provide information on the regulations to be complied with, details of the physical, toxicological and ecological properties, together with handling, transport, storage and safety aspects. The ETAD (Ecological and Toxicological Association of the Dyestuffs Manufacturing Industry) has been issuing safety data sheets to affiliated dyestuff manufacturers since 1974 in order to support these efforts and to provide information on the regulations to be complied with, details of the physical, toxicological and ecological properties, together with handling, transport, storage and safety aspects. The ecological details are listed under point 8 in the SDS, i.e. whether substances are biodegradable, toxic to fish, harmful to waste water bacteria, and details of the water pollutant toxicity classification of the product. More information concerning the exact chemical composition of the products, proper disposal and the by-product level present will be desired in future. If the content of the safety data sheet should change within twelve months of delivery, the supplier must automatically forward the client an updated version of the safety data sheet.

Safety stitch: A stitch formed by an over edge stitch reinforced by a chain stitch (or sometimes a lockstitch) further in from the material edge.

Safety valve: A pressure relief valve actuated by inlet static pressure and characterized by rapid opening or 'pop' up action.

Saffron: A fugitive yellow dyestuff derived from the flowers of the crocus; used formerly to some extent.

Sales invoices: Invoices of the goods sold.

Sail Cloth: A firm fabric in plain colours in plain or basket weave. It is made from cotton, or polyester and cotton, and is stiff and hard wearing. Used for trousers, dresses, children's clothes, men's summer jackets etc.

Sail test: Combined wear and laboratory test for Static charge. A test subject wearing a waist slip made from the fabric to be tested passes a polyester sail

fixed in an air conditioning chamber. The slip rubs against the sail and is charged. A second person assesses and records the charging and discharging per unit of time.

Sailcloth: A canvas/duck that is used for the manufacture of sails. Dense and tight, impregnated heavy fabric (linen, cotton, hemp, synthetic fibres) in plain weave. Used for tarpaulins, awnings, sails, window blinds, etc. Laminated fabrics are also finding use in this market.

Sail duck: See **Duck**.

Saint Andrew: In embroidery a stitch forming a St. Andrew cross in a square.

Saint Georges: Unbleached French linen of medium quality.

Saint Jago: Cotton goods in Sierra Leone, Africa.

Saint Jean: Coarse, unbleached French linen made in various widths.

Saint Lucie: Very fine French silk yarn.

Saint Maur: French serge made of pure silk or mixed with wool.

Saint Nicolas: French woollen serge, used by the army.

Saint Omer: Narrow, 17th century English worsted fabric.

Saint Rambert: Unbleached French linen.

Saint Remy: A grade of French organzine or raw silk.

Saint Vincent: Variety of raw cotton from the West Indies.

Sakalleridis: Valuable Egyptian Maco cotton.

Salampore: The tough fabric made in Nellore, India as work wear. Salampores were the preferred dress material for the slaves on the West Indian Plantations. But the West Indian Emancipation Act of 1833 sounded the the death knell of salampores, as “freed negroes refused, very naturally, to wear the grab of their slavery.

Salisbury: White Sort of white English woollen flannel.

Salt: An ionic compound that is formed by a neutralization reaction (reaction of an *acid* with a base) The best known salt, common salt, or sodium chloride (NaCl) is extensively used as an electrolyte in dyeing. Sodium sulphate is also used for this purpose. Many of the chemicals used in dyeing are technically salts, including many dyes.

Salt accumulation: When recycling e.g. rinsing water which is sometimes still cleaned in in-house waste water treatment plants, the salts remain dissolved in the water and are not removed. When the recycled water is reused

as process or rinsing water, more salt is added to the salt concentration already present from the first use of the water. If part or all of the water is used several times, the salt water concentration continues to increase imperceptibly and may become a source of interference.

Salt Dyes: See **Direct dyes**.

Saltillo: Woollen blankets made by the natives of Northern Mexico, with a large and richly ornamented medallion, consisting of various coloured concentric bands. This medallion is in the center of a ground covered with small all-over geometrical designs in vertical or diagonal rows. The leading colours of these blankets are blue or red with smaller quantities of green, yellow and black. The weave is usually very fine; the selvages are finished smoothly and without overcasting and the ends are finished with fringes. These blankets are used as ponchos or serapes.

Salting: This refers to incorrect precipitation of dissolved dyestuffs or textile auxiliaries as a result of excessive addition of electrolytes which results in bronzing and insufficient fastness to crocking.

Samardine: Plain French serge, made with eight ends and four picks in a repeat.

Samarkand: Medium size rugs made in Central Asia of wool, silk or cotton web and loose cotton or silk pile, tied in Senna knot. The design shows Chinese influence with five or less medallions, fret-work patterns and odd, stiff flowers. The colours are yellows, blues, reds, browns and white.

Samis or Samit: A medieval fabric made with very heavy silk or hemp warp containing six threads and flat gold filling (tinsel). Originally was made in Italy. It is believed by some to have been similar to velvet.

Sample: (1) A portion of a lot of material which is taken for testing or for record purposes.

(2) A group of specimen used, or observations made, which provide information that can be used for making statistical inferences about the population(s) from which the specimens were drawn.

Sample blankets/section blankets: Woven trial pieces with differing sections across the warp. These sections may vary in colour, yarn type and/or weave.

Sample, bulk: See **Bulk sample and Lot sample**.

Sample, discrete: See **Discrete sample**.

Sample, laboratory: See **Laboratory sample**. A sample taken to represent the lot sample or the original material and used in the laboratory as a source of test specimen.

Sample, lot: See **Lot sample**.

Sample skein: Skein reeled from the package or beam of the laboratory sample, and used in the laboratory as a source of specimens.

Sampling unit: An identifiable discrete unit or subunit of material that could be taken as part of the sample.

Sampling Vessel: This is a small vessel attached to the dyeing machine, in which quantities of sample are switched to the secondary liquor cycle. These are connected to the dyeing machine so that the test specimens (samples) can be incorporated into the liquor circulation during dyeing. The interconnecting valves between the dyeing machine and the sampling container should be closed to remove the sample. The liquor should then be drained off from the sampling vessel and this must also be vented if necessary.

Samuhu: (1) Good bast fibre, yielded by a species of the *Chorisia* tree in Argentine; used for cordage; (2) Silky, flexible but short fibre, yielded by a species of the *Bombaceae* in Paraguay; used for ponchos, etc. The Indians use the net-like bast for various purposes.

Sancowad Process: Short liquor dyeing process (Sandoz) for fully fashioned articles, stockings, socks, etc. with liquor-to-goods ratios of 1 : 1 to 1 : 2, using special textile auxiliaries which produce microfoam.

Sand: Used as a filter medium in fibre manufacture, particularly used in spinning packs for nylon or polyester production.

Sand Crepe: A type of crepe. A typical sand crepe with apparel weight will have a texture of 90 x 70 and is woven in small broken crepe weave. Short yarn floats in no discernible pattern give an irregular surface texture. Used for dresses and blouses. See **Crepe**.

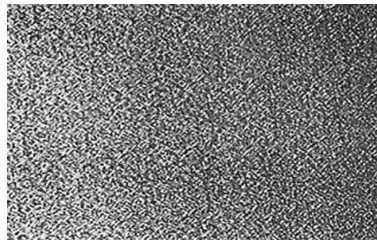

Sand filter: A layer of sand through which water or wastewater is passed and filtered.

Typically the sand is contained in open concrete tanks. **Rapid gravitys and filters** have a downward flow through the sand and are common in water

treatment. *See also* **biflow filter, continuous backwash up flow sand filter, moving bed sand filter, pulsed bed sand filter, slow sand filter, upward flow sand filter**. In stormwater management, a 0.5 m deep sand bed, down through which stormwater passes in order to remove much of the suspended matter before the stormwater enters the sewer. The typical sand size is 0.5 mm. The sand filter may be in an underground structure or it may be built just below ground level with a cover of topsoil and grass. Other storm waters and filters include *linear stormwater sand filter* or *peat sand filter*.

Sandarc Gum: Natural Resin from the bark of a North African cypress. Lemon yellow pieces, powdery, fresh surface fracture with glassy lustre. Melting point approx. 135°C. Soluble in alcohol, chloroform, distilled oils. Only used occasionally for silk ribbon finishes and lacquers.

Sanding: Sanding is distinguished from Emerizing in that only one roller is used as a tool per machine, whereas several rollers work on the fabric in emerizing. A guide roller advances the fabric as close as possible to the abrasive roller which operates at high speed. The distance determines the sanding effect and must therefore be accurately adjusted.

Sandwash silk: Firstly, the silk is treated with an enzyme (protease) in the drum washing machine in a weak alkali bath with a low liquor-to-goods ratio. This causes the fabric to peel slightly and at the same time, the mechanical strains on the fabric cause a slight napping of the silk fibres. Together with the appropriate final finish, this achieves the characteristic sandy soft handle. Ready-to-wear items are often finished in this way.

Sandwich: A method of preparing fibre mixtures by layering them horizontally in alternating layers with all elements in the proper proportion. Vertical sections are cut and fed to the next machine in the process, where blending is effected.

Sandwich dyeing: Method of impregnating used predominantly for synthetic fibrous material, mainly to dye light shades whereby the material, rather than being fed through the liquor and squeezed, passes in close contact between two endless absorbent cloths which constantly absorb liquor. Dyestuff from these liquors is thus transferred to the material to be dyed.

Sandwich effects in dyeing (greyness): A dye migration phenomenon in continuous dyeing. The dye migrates from the surface to the interior of the textile material or the dye is washed off the textile surface. As a result, the textile material only appears to be dyed in the middle whilst the surface has a whitish appearance which is often referred to as "greyness". The problem can be remedied or prevented by using appropriate dyeing systems.

Sanfor Knits: Brand name, which is no longer protected and which is a control standard, relating to cotton knitwear. The standard is achieved by Compressive shrinkage with additional light synthetic resin finish.

Sanfor-set: Brand name which is no longer protected which is a control standard. Limited to effects of textiles which have been finished using the Liquid ammonia process and are characterized by good shrink resistance under drying conditions in a tumbler drier. This process can also be used for lighter cotton qualities.

Sanforise: Mechanical compacting is one method of reducing residual shrinkage. The process forces yarns closer together and the fabric becomes thicker and heavier. As a result of this, the net yardage yield is reduced. A Sanforizer is a fabric compactor developed by Cluett Peabody. The term Sanforized, is their registered trademark and is used to market fabrics that meet certain shrinkage specifications. The term Sanforized is now generally accepted to mean a fabric that has low residual shrinkage and the term Sanforizing is used to describe shrinkproofing processes. While the patents on the machinery have expired, the trademark is actively promoted by Cluett Peabody. The effect of Sanforizing can be seen in figure 68 which shows that open fabric structure has been closed up somewhat. The process, figure 69, consists of a range where the fabric is first moistened with steam, to make it more pliable, run through a short tenter frame (pup tenter) to straighten and smooth out wrinkles, through the compressive shrinkage head and then through a Palmer drying unit to set the fabric. The fabric is wound into large rolls under minimum winding tensions. If the winding tension are excessive, the fabric will be pulled out and the degree of compaction lessened. Usually, a lubricant is added in preceding operations to assist in the realignment of the yarns as the fabric runs through the compactor. Selection of the proper lubricant is critical for some fabrics.

Sanforized: A material which has gone through the Sanforize treatment.

Sanforized Mark: A crimped, rippled, wavy, pebbled, or cockled place in the cloth showing distortion of the texture, produced due to the wrong operation in the Sanforising process.

Sanforset®: A trade mark of Cluett, Peabody & Co., Inc., denoting a controlled standard of shrinkage performance originally developed for denims. Fabrics bearing this trademark will not shrink under home-wash, tumble-dry conditions because they have been subjected to a liquid ammonia treatment and compressive shrinkage.

Sanfor-Set®: See **Ammonia process**.

Sanforising mark: See **Sanforized mark**.

Sangati: One of the finest grades of plain Dacca muslins.

Sangi: Cast Indian satin, made of tussah silk and cotton.

Sanglier: Closely woven French fabric made of hard twist worsted or mohair yarn.

Sanitary wear: In the broadest sense, sanitary wear refers to so-called anti-rheumatic clothing. The alleviating effect is provided in conjunction with electrostatic properties and high thermal retention (heat retention).

Sanitation: Process to control the germ count with the aim of avoiding the risk of undesired germs spreading, achieving an inhibiting effect and/or counteracting damage to material caused by microbes. Antimicrobial finishes; Sanitized finishing.

Sanitised Finishing: (Antimicrobial finishes). Protects textiles against the growth of bacteria and mycotoxins, achieving a deodorizing effect at the same time (sanitized finish). Currently used for lining fabrics, sportsgoods, stockings, etc. Sanitized finishing is achieved using e.g. quaternary ammonium compounds, halogenated phenols, salicylanilide derivatives, neomycin sulphate, etc.

Sansevieria Fibre: A fibre obtained from the leaves of various species of plants of the genus sansevieria, (tropical Africa, Sri Lanka). The sansevieria fibre from Sri Lanka is finer than the African equivalent, similar to Mauritius hemp. Use: for string, matting and coarse cloths.

Santos: Brazilian cotton, with a silky, white staple.

Sanyan: Variety of wild silk from West Africa.

Sanz: New Zealand. Standards organization.

Saponide: Term used abroad, especially in France, to refer to anionic organic detergent base materials, with the exception of soaps.

Saponification: Specifically in relation to manufactured fibres, saponification is the process of removing part or all of the groups from acetate or triacetate fibre, leaving regenerated cellulose.

Saponification number: The saponification number indicates how many mg of potassium hydroxide are required to saponify 1 g fat.

Saponised Yarn: Cellulose acetate filaments are treated to produce very strong yarn.

Sappy: Wool containing a large percentage of natural grease and subject therefore to excessive shrinkage.

Saraband: Small and medium size Persian rugs made of cotton warp and weft and close and short wool pile, tied in Senna knot. The design consists

almost without exception of rows of pears and many narrow borders in dark red, blue, etc.

Sarakhs Rugs: Heavy, all-wool Persian rugs, the long and close pile is tied in Ghiordes knot. The design consists of medallion and floral figures chiefly in rich red and blue.

Saran Fibre: A manufactured fibre in which the fibre forming substance is any long chain synthetic polymer compound of at least 80 % by weight of vinylidene chloride units ($-\text{CH}_2-\text{CCl}_2-$). This fibre, which has an excellent resistance to sunlight and weathering, and is used in lawn furniture, upholstery, and carpets.

Sarcina: Sarcina are earth- and air-borne bacterial microbes (in coccus or cuboidal form, sporadically forming spores). Also occur in perspiration (up to 45% on the upper arm). Sarcina can be harmless but also pathogenic.

Sardasi: Indian velvet, embroidered with gold or silver threads.

Saree: See **Sari**.

Sargia: Medieval Italian twilled fabric, made of wool and silk.

Sargues: French serge made of linen and carded wool.

Sari: A sari is a wrap-around robe used by Indian women which is often printed with many patterns. It is used as plain dyed also.

Sarille: Trade name for Courtaulds fibre. Soft cellulosic fibre, developed from viscose and used to produce warm fabrics. Mainly used in dress fabrics, household textiles as blankets, and often mixed with other fibres, such as wool, to reduce the cost.

Sarong: A Sarong is a Malaysian item of clothing for women which often has large characteristic batik patterns.

Sarplar: In England a bag of wool measuring 2,2,40 pounds.

Sarplier: A coarse, strong, plain woven cotton fabric; used in England for baling wool.

Sarpuz: Trade term for Persian and Anatolian knotted wool carpets; used as floor covering.

Sarraux: French linen canvas, made with blue checks; used by sailors for trousers.

Sarsenet: Plain, woven stout piece dyed English cotton cloth finished with high gloss, often calendered to give the appearance of a twill; used for lining, etc.

Sarsonet: Originally a fine silk Arabian fabric, it is now a net or veiling fabric used in millinery. Made from silk, nylon or polyeaster.

Sartex: Sartex is a Swiss association for textile labelling.

Sase: Acronym for stress at specified elongation; the stress experienced by a yarn or cord at a given elongation.

Sash: A waist-scarf.

Sash Ada Tari: Arabic term for bleached tanjibs (see) with a dark blue or lavender striped heading; used for head covering by the natives In Egypt.

Sashing: refers to strips of fabric that are sometimes put between blocks of a quilt to form a pattern or make the quilt larger. They are often made of patchwork.

Sateen: Similar to Satin but made in cotton or spun synthetic. Various satin weaves may be used in making sateen, but the 5 harness warp flush satin weave is by far the most common. It is soft and has a sheen and is often of loose construction. It is usually made in plain colours only. In pure Sateen weave the surface of the fabric consists of mostly weft floats only. The most common use of sateen is in lining of coats. It is made in different constructions. One

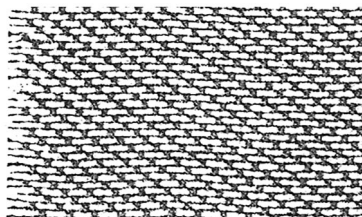
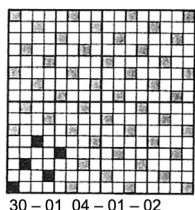

typical warp flush lining sateen texture is 110×60 , with 24s carded yarn in the warp and filling. For weft flush lining sateen a construction of 70×120 with 30s warp and 40s weft may be an example. The fabric is usually starched and calendered or shreinerised to get the glossy finish. Another use is as curtain linings. It does not wear particularly well; seams tend to pull and crack mark appear where hems are pressed.

Sateen Fabric: A fabric made from yarns with low lustre, such as cotton or other staple length fibres. The fabric has a soft, smooth hand and a gentle, subtle lustre. Sateen fabrics are often used for draperies and upholstery.

Sateen, fine: Fine sateen is used for dress goods and sleeve linings are made from combed mercerized yarns. A thread count of 140×90 with 60s warp and 80s filling could be used for such a sateen. Fine heavy sateens, made from 8-harness satin weaves are called Venetian.

Sateen, heavy: Are used for outer wear such as windbreaker jackets and sky suits. In construction, finish, and uses these sateens are quite similar to shee gabardine, but normally they are slightly heavier.

Sateen, tickings: They are used for pillow covers and similar articles. They are heavier than lining sateens, a typical construction being 100 × 50 with 12s warp and 20s filling.

Sateen: (a) A fabric made in sateen weave.

(b) Weave A weft-faced weave in which the binding places are arranged with a view to producing a smooth fabric surface that is free from twill (q.v.).

Note: To prevent confusion with “satin”, it is preferable to refer to this as “weft sateen weave”.

Sati-drap: French dress goods, made of cotton or silk warp and woollen filling of the same colour, forming a weft satin. It is fulled in the finish; obsolete.

Satin: Examples of satin weave fabrics are cotton damask, sateen, ticking, linen damask, silk, rayon or other synthetic damask, satin.

Satin, enness (silk): Warp of organzine and weft of tram with a 45° diagonal weave structure. Evensided twill with strongly marked slant ribbed effect.

Satin: A fabric that is very smooth on the right side (although sometimes both sides are satin weave). This smoothness is produced by weaving in an interlaced pattern. Satin weave fabrics are produced from all yarns including silk, acetate, nylon, viscose, polyester, cotton.

Satin-back: Any fabric of any fibre where the reverse side is of satin weave.

Satin, duchesse (silk): a thicker, richly lustrous satin.

Satin: (1) Name derived from atlas or satin weave. Generic term for various, mainly lustrous materials, predominantly manufactured using 5-weave satin. Worsted satins are either napless (e.g. satin de Chine) or finished with a fine nap; carded satins almost always have a napped finish. Fabrics with a particularly napped finish have an intense shine which is further emphasised by the weave. (2) Smooth fabric (silk, viscose, wool, flax, cotton, etc.) with high sheen, in atlas or satin weave, e.g. Duchesse satin, cloth; liberty, etc., see 1.

Satin d’Amerique: Satin made of mixture of silk and agave fibre.

Satin Back: Velvets or taffeta and other ribbons made with a reverse side of satin.

Satin Berber: Stout worsted fabric, made in satin weave and finished with a lustre.

Satin Bonjean: French worsted trousering, fulled in the finishing.

Satin de Bruges: Upholstery satin of silk and wool.

Satin Check: Highly finished English cotton fabric, woven in checks.

Satin de Chypre: Obsolete French silk satin.

Satin de Laine: (1) French twilled drapery, made of English worsted, in solid colours, printed or brocaded; (2) French dress goods and cloaking made in various coloured brocaded patterns in satin weave.

Satin de Lyon: Silk satin made with a twilled back, and finely striped face; used for lining.

Satin Cloth: A lightweight woollen dress goods, made in satin weave and lusted.

Satin Damask: (1) the best grade, lustrous linen damask, used for table linen; (2) rich silk satin with fancy Jacquard designs woven either in fancy weaves or in pile.

Satin Delhi: Fine worsted satin.

Satin Duchesse Fine, stout and very lustrous silk satin, woven in eight-end satin weave.

Satin Ermine: 40-end French silk satin ribbon, made with two sets of warp, one set forming a taffeta back, the other the satin surface, similar to the fur or the plush.

Satin Fabric: A traditional fabric utilizing a satin weave construction to achieve a lustrous fabric surface. Satin is a traditional fabric for evening and wedding garments. Typical examples of satin weave fabrics include: slipper satin, crepe-back satin, faille satin, bridal satin, moleskin, and antique satin.

Satin Figaro: Eight-end silk satin dress goods or millinery trimming, the warp being of alternately different coloured threads.

Satin fabric, warp knitted: The technical face of a satin fabric is similar to the face of a locknit fabric. The technical back of the fabric is smoother and shinier due to longer underlap movement of the front guide bar. It contracts in a widthwise direction when leaving the knitting zone due to longer underlap movement of the front guide bar. It has a curling tendency and greater risk of snagging.

Satin finish: High gloss given to cotton, wool or silk fabrics by calendaring.

Satin Foulard: Smooth and highly finished silk foulard.

Satin Grec: Solid coloured silk satin lining or dress goods made with single warp and high finish. Satin Grec is a 12-harness satin, in which a taffeta point is added to each place of interlacing, thus giving the cloth a much firmer hand.

Satin Jean: A stout, heavy cotton jean, made with a highly finished, finely twilled face.

Satin Lisse: Twilled, highly finished cotton dress goods in France, printed with small designs.

Satin Luxor: Rich, stout silk satin dress fabric, made with a corded face.

Satin Marabou: Thin, silk satin made with single marabou yarn (see) for warp.

Satin Merceilleux: A very soft silk dress fabric, woven in a seven-end satin weave and given a very high finish.

Satin National: Six or eight-end French silk satin dress goods.

Satin Onde: Five or eight-end silk satin, made with single warp; used as dress goods or millinery.

Satin Quilt: Bleached or coloured cotton quilt, made with fine warp and ‘filling, woven plain, a second, coarse filling forming raised patterns.

Satin Regence: Stout, rich silk satin dress fabric, made with ‘fine runs weftwise.

‘**Satin a la Reine:** Closely woven six-end silk satin.

Satin Rhadames: Fine silk satin dress fabric, made with fine diagonal lines running across the face.

Satin Royal: Double faced, silk satin with twilled stripes crossing the material.

Satin Sheeting: English cotton back thick satin, made of waste silk; used for dresses, etc.

Satin soleil: A version of satin weave, Satin Soleil shows a satin-like surface with a cross line appearance.

Satin stitch, in embroidery: Proceed with Straight Stitches worked closely together across the shape, as shown in the diagram. If desired, Running Stitch or Chain Stitch may be worked first to form a padding, underneath, this gives a raised effect Care must be taken to keep a good edge. Do not make the stitches too long, as they would then be liable to be pulled out of position. This stitch may be worked from right to left or left to right. The number of threads over which the stitches are worked may vary depending upon the effect desired.

Satin Stitch: The satin stitch is an over and over stitch and is used on materials of all kinds for marking linen, etc. The *padding* is the first step and should be done in long even stitches placed closely and over one another in the center. The size and proportions of the figure or letters determine the size of the thread. Fine thread gives the best results. The outline should be run twice;

this keeps the edge firm. An even darning or basting stitches, chain stitches or outline stitch may be used if the space is not too small. The padding may be worked in an embroidery hoop to keep it smooth and even. Scallops may be padded in the same way or worked flat.

Satin Stripe: A fabric of almost any fibre, including cotton, that has a satin weave shiny stripe alternating with a contrasting stripe of a different weave of thickness of the yarn, even of different colour.

Satin Sultan: French dress goods and cloaking, also a lustrous East Indian silk fabric.

Satin Surah: Twilled, very soft surah, finished with great lustre.

Satin Tick: Very stout, cotton fabric, made in satin weave; used for upholstery.

Satin Turc: (1) four-end satin in France, made with single warp. It is given a high finish and is used for shoe tops; (2) French fabric made of wool and silk warp and wool filling in seven end satin weave; used for shoe tops, trousers, etc.; similar to lasting. **Satin Vigoureux** Dress fabric having a satin face or satin stripes, the warp yarns being printed according to the vigoureux process (see), giving a mottled colour effect.

Satin Weave: One of the basic weaves, plain, satin, and twill. The face of the fabric consists almost completely of warp or filling floats produced in the

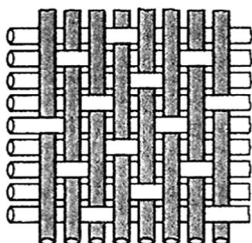

repeat of the weave. The points of intersection are distributed evenly and widely separated as possible. Satin-weave fabric has a characteristic smooth, lustrous surface and has a considerably greater number of yarns in the set of threads, either warp or filling, that forms the face than in the other set.

Satin, all silk: Is made with 300×100 construction with 18/20 denier warp and filling.

Satin, crepe-back: 50 to 100 denier acetate warp and 75 to 120 denier dull crepe twist acetate in the filling is used for this fabric. Textures range from 200×50 to 400×100 . A normal construction is 300×70 with 75 denier bright yarn in the warp and 100 denier dull crepe twist yarn in the filling.

Satin, plain: (Panne): A typical construction is 110×40 to 300×80 , with 75 to 150 denier lustrous yarn used in the warp and 75–300 denier yarn in the filling. The main feature of plain satin is its lustre and beauty.

Satin Zephyr: French dress goods, made of cotton warp and woollen filling, with a weft plush satin weave, fulled in the finish.

Satine: Twill lining that are given a glossy finish are called satine, sometimes.

Satinet: A cheap clothing material similar to cassimere, made with a cotton warp and a filling of short, inferior, shoddy wool which is mixed with enough long wool to enable it to be spun and woven in a way to bring that filling to the surface of the cloth; afterwards fulled, sheared, and the pattern printed on the face.

Satinette: Satinette is a combination of Satin and finette (cotton twill napped on one side in linen goods). The warp consists of lustrous viscose filament, the weft is cotton; the weave is in the form of 5-weave warp satin. The lustrous warp is generally found on the fabric face, whereas the cotton warp on the reverse side of the fabric is very napped. Used for night-shirts and pyjamas.

Saturated vapour: A vapor that is in equilibrium with its solid or liquid phase. A saturated vapor is at the maximum pressure (the saturated vapor pressure) at a given temperature. If the temperature of a saturated vapor is lowered, the vapor condenses. Under certain circumstances, the substance may stay temporarily in the vapor phase; i.e. the vapor contains more than the equilibrium concentration of the substance. The vapor is then said to be a supersaturated vapor.

Saturation, in colour chemistry: The attribute of colour perception that expresses the amount of departure from a gray of the same lightness. All grays have zero saturation (ASTM). See **chroma/chromaticity**.

Saturation bonding: A process of binding fibres into a nonwoven fabric by soaking the web with an adhesive.

Saturation Bonding: A method of making nonwoven fabrics in which a fibre web or batt is treated by overall application of an adhesive in the liquid form.

Saturation Limit: (1) The maximum intensity or purity of a colour. If the colour is as brilliant as possible, it is at saturation; if the colour is subdued or grayed, it is dull, weak, and low in intensity. (2) The upper limit concentration of a solute in a solvent, i.e., no more solute can be dissolved at a fixed temperature and pressure.

Saturation Value: The maximum amount of dye that can be absorbed by a textile fibre under defined conditions.

Saturator: A machine for thoroughly wetting fabrics with aqueous solutions or allowing interchange of liquor in wet-on wet processing like continuous bleaching, mercerization etc.

Saturator, in ETP: A pressure chamber in which air can be injected into water at (say) 4 atm pressure—e.g. as a part of *dissolved air flotation*. A saturator can be either unpacked (empty) or packed with stones or plastics medium. Packing helps to break up the bubbles and flow pattern. The retention time is normally from 30 to 60 s.

Saueressig Printing Machine: In this machine, the printing heads are arranged vertically one above the other, unlike conventional roller printing machines where they are positioned around a central cylinder. The colour boxes, doctor blades and furnisher rollers are all mounted on a hinged sub-frame which can be swung to one side of the Saueressig roller printing machine to facilitate the changing of printing rollers.

Saueressig roller printing machine: Roller printing machines in which the central cylinder is replaced by individual cylinders for each printing roller.

Savage: Bleached, stout woven and hard finished cotton shirting in Venezuela, used for collars and cuffs.

Savonnerie: French-made rug made in imitation of Oriental knotted rugs in rococo patterns.

Saw-tooth effect: Defect in screen printing in the form of graduated (stepped) repeated profiles of fine pattern details which run askew; particularly undesirable with fine floral designs or figured patterning, etc. Correction: e.g. by using even finer gauze screen, use of photosensitive screen coatings with a crossed mesh effect and by correctly developing illuminated screens.

SAWTRI: (South African Wool Textile Research Institute).

Saxoniene: French silk armure dress good of small patterns, having the warp in various colours; obsolete. Saxony (a) The finest class of wool, having a short, very fine but strong and elastic staple, with excellent felting properties owing to the large number of serrations; used for the best grades of fulled fabrics; (b) A worsted fabric, originated in England during the 19th century, made with a warp of half-bred, English and Botany wool and the filling of Saxony or South-Down wool; (c) Same as merino in Scotland; 4, means a white flannelette in Canada.

Saxony: Originally made in the province of Saxony, Germany, the name has to be used to describe any soft, plain weave woollen or worsted cloth with a slight nap. High grade yarns are used so the term always implies a good quality cloth. It may be plain or in small checks.

Saxony: (1) A high-grade fabric for coats, made from Saxony Merino wool. (2) A soft woollen with fancy yarn effects, used in sport-coat fabric. (3) A highly twisted worsted knitting yarn. (4) A term describing a cut-pile carpet having highly twisted, evenly sheared, medium-length pile yarns.

Say, Saye: An all-worsted, four-harness serge of black colour, made in England since the middle ages until the 19th century; it was used for linings and shirts by certain religious orders and for aprons by the Quakers. It was usually made of Holland, English or Spanish wool.

Say Cast: Coarse wool taken from the tail part of the fleece.

Sayette: General name in France for various twilled or plain woven goods mixed with little silk. Used for lining and furniture cover.

Sayetterie: French term denoting woollens containing some silk yarn. Schappe See **Shappe**.

SBR: See **Sequencing Batch Reactor**.

Scaffolding effect: A mixed fabric sample (e.g. cotton and polyester) has different burning properties (e.g. in a vertical flammability test) than a corresponding sample made from one of the pure fibre components. Therefore the fibre portion made from polyester fibre for example promotes better burning of the associated cotton as it is worked and spun into the blended yarn almost as a stable scaffold. The scaffolding effect therefore benefits the relative low combustibility of the polyester fibres (at best melting), whereas the relative high flammability of the cotton is increased still further by the "loose" distribution in the scaffolding, which increases the oxygen available.

Scallop: Curves or indentations along the edge of a fabric.

Scalloped Selvedge: An abrupt, narrow indentation in the selvedge of the cloth.

Scarf, in apparel: An oblong or square piece of cloth worn for warmth or as decorative item.

Scanning in photo-engraving: This process refers to the breaking up of coloured areas into colour points of varying sizes, which when observed give the optical impression of different colour intensities due to blending of the colour lying between the points on the printbase.

Scarf Cutting Machine: After the fringes of scarf fabric have been twisted and set, the individual scarves must be cut longitudinally or transversely along the unwoven warp or weft thread which is done on this machine.

Scatter rug: A small rug which is designed to be flexible and is usually cleaned by laundering.

Scattering: Diffusion or redirection of radiant energy encountering particles of different refractive index. Scattering occurs at any such interface, at the surface, or inside a medium containing particles.

Schappe (slivers): These are wool like slivers formed by repeated combing and consist of parallel running filaments of 50–250 mm. in length. An important factor in spinning this material is the regularity of slivers. These are processed on a spreader in a single fleece 3 m. long and then by repeated drawing into a uniform ribbon.

Schappe (Silk): (Chappe, Floret silk). This is taken from the beginnings and ends of the cocoon which can no longer be unwound after the vegetable glue has been decomposed in a putrefaction process. The schappe undergoes further processing in a similar spinning process to that used for worsted yarn. The comber waste which falls away provides Bourette. Schappe is used e.g. for machine sewing silk and for strong silk fabrics. See **Silk**.

Scherli: See **Broche/Scherli**.

Schiffli Embroidery: Shuttle embroidery, the machine being run by a motor instead of by hand. The movement of the carriages is caused by motor power and the pantograph is operated by hand. The cross stitches are visible on both sides of the goods and the work shows the bobbin threads on the back of the embroidery.

Schiffli Lace: The name of a machine (Embroidery) producing various effects on lightweight fabrics.

Schmidt's machine: A machine used to dye loose cotton, consisting of two cylindrical vats one mounted on the other. The outer vat hold the liquor and the inner one with a false bottom holds the material to be dyed. After loading the material its kept in position by a copper wire sieve. A paddle wheel is also provided at the centre of the vats to help the liquor to move upwards. The liquor is heated by steam pipes and is raised from the outer vessel and poured over to the inner vessel which percolates to the bottom due to the vacuum produced in the bottom due to the movement of the liquor and the paddle.

Schooner Pants: Spring bottoms, after the sailor style.

Schreiner: A fabric finishing process which smoothens the right side, often impressing a pattern at the same time.

Schreiner Calendar: Often it is desirable to increase fabric lustre without overly thinning the cloth. Schreiner is a method of doing this. Schreiner is actually embossing by the use of a very special pattern. The pattern roll has anywhere from 250 to 350 lines per inch, etched at 26 degrees from the vertical. These lines are lightly embossed into the fabric and being regular,

reflect light so as to give the surface a high lustre. This operation gives a silk-like brilliance to cotton fabrics. Schreinermercerized cotton fabrics gives the nearest resemblance to silk.

Scoop, In Zipper: See **Elements, interlockable.**

Scorch Test: American test method (AATCC) to determine the amount of damage to hardenable synthetic resin finishes due to Chlorine retention on cellulose textiles. Also records the specific buffer capacity for each synthetic resin and each catalyst. Working principle: chlorine treatment (2.5 g/l active chlorine, liquor ratio 1: 50, 25°C, pH 9.5, 15 min), rinse, dry, condition, scorch or press between two metal plates with constant pressure and temperature (185°C, 30 s), condition. Assess by comparing the percentage average decrease in breaking strength and any yellowing which may occur.

Scorching: The tendering of a fibre surface by heat so as to change the colour and texture of the surface.

Scotch Carpets: Pile carpets, similar to the Kidderminster, with design on both sides but in different colours.

Scotch Checks: White muslin with plaid checks in coloured cord. Used for dresses, etc.

Scotch ell: 37.2 inches.

Scotch Fingering: Soft twist woollen yarn for knitting.

Scotch Gingham: Trade name for the finest grades of gingham.

Scotch Plaid: Coarse, very durable twilled woollen fabric, made of native wool in Scotland in various tartan patterns.

Scotch Rug: A rag rug, made with a coarse two-ply cotton warp and long and narrow strips of wool rags.

Scotch Tweed: Woollen tweed made in twill weave using a white warp and highly coloured weft yarns. It has a rough, shaggy appearance, and is made in various weights for suits and overcoats.

Scotchguard: A registered showerproof finish applied to some fabrics.

Scott: A Highland tartan, composed as follows: Wide red field, split in the center by a narrow green stripe with a fine black line near each edge of the green; green stripe (measuring half the width of the distance between the edge of red field and the nearest black line) ; group (as wide as green stripe), composed of three red and two green stripes, the latter being wider and split in the center by a fine white line; green stripe, as above.

Scour: Essentially, thoroughly washing fibres or fabric to remove contaminants. Yarns and fabrics may be dirty, contain natural waxes or oils, or have been

treated with size or lubricants used in spinning, weaving or knitting. These can all interfere with dyeing, often leading to non-level results. Scouring is a large topic, and the process used depends on the fibre type and its condition. "True" scouring of greige cellulosic fabrics is typically done, after desizing, at the boil or at higher temperature in pressure vessels, with as much as 10 grams sodium hydroxide per litre of water, plus surfactants, and the process may last for several hours. Commercial scouring of wool may use solvents, similar to dry cleaning, as part of the process. White fabrics sold at retail have normally be scoured at the mill; "natural" fabrics usually have not (some "natural" fabrics have been scoured but not bleached).

Art dyeing literature often refers to what amounts to laundering as scouring. This is inadequate for greige fabrics, but often quite acceptable for "white goods". A long machine wash with the hottest water possible, about a gram of *soda ash* per litre of water (about a teaspoon per gallon) and some (preferably optical brightener free) detergent, followed by two rinses is usually acceptable. Sodium hexametaphosphate may be helpful if the water is hard. Woven white cottons often contain starch that will not be removed by such a limited process.

Scoured wool: Wool from the bulk of impurities has been removed by an aqueous or solvent washing process.

Scouring: A process where mill and natural dirt, waxes and grease are removed.

Scratch felt: Cheap quality woollen fabric made to resemble camel cloth. Poor wearing qualities.

Scray: That part of a processing machine where the fabric can be stored. The storage can be for giving time for reaction or synchronize the speed of one part of a machine to another, to avoid tension etc.

Screen: (1) A hollow, cylindrical, coarse-mesh wire device used in pickers and certain openers to form the loose staple stock into a sheet, or lap. The screen is mounted horizontally on a shaft on which it revolves freely. (2) A stencil used in screen printing. It is made of fine cloth, usually of silk or nylon, finely perforated in areas to form a design and mounted on a frame. The paste containing the dye is forced through the perforations onto the fabric, leaving the design. A series of screens, one for each colour, is used for multicoloured designs. (Also see **Printing**.)

Screen, in ETP: (1) A sieve made of a flat sheet of wire mesh or punched steel plate for separating granular material into sizes (*classification*). It can also be made of parallel, wedge shaped wires or bars or round wire either flat or formed into a cylinder, as in the *trommel*. In a *mechanical sorting plant*,

screens are an inexpensive first step and may also be used intermediately. (2) In the treatment of water or wastewater, a device that removes larger solids out of the flow. At reservoir intakes, screens are usually racks of massive bars. The bars may be vertical, horizontal or at a slope. They may be cleaned mechanically or by hand. At wastewater treatment works, and sometimes water treatment works, screens are part of *preliminary treatment*. *Coarse screens, medium screens* or *fine screens* may be used. They are usually designed for a velocity through the bars or mesh of 1.2 to 1.5 m/s at maximum flow. The most common are *bar screens*. Other types include *belt screen, cup screen, disc screen, drum screen, mesh screen, vibrating screen*. (3) An embankment or a wire mesh fence, up to 3 m high, built around a *landfill* especially on its lee side to catch wind blown refuse.

Screen Coating: The rotary printing screen system is based on seamless rotation screens. If the perforations in the rotary screen are sealed in places using a spec. lacquer (the rotary screen is then engraved) the coating unit can be used as a single-colour printing unit for a pattern. Light squeegee pressure makes it possible to apply a small amount of paste for vertical passage of the cloth. Hence coating will be the basis for the screen engraving to make the design. The coating will be as per the engraving methods adopted. For example if a manual photographic method is adopted the coating will have photographic chemical along with it. Coating is done using a coating machine and a squeeze to apply on the flat or rotary screens. After the coating the screen is cured for the coating to adhere to the screen so that it will withstand the wear and tear during printing operation in unengraved portions.

Screen Engraving: The method of engraving the design (one colour on one screen) on the coated screen. There are different methods available. Like manual photographic methods, Laser engraving, inkjet engraving etc.

Screen Films In Photo Engraving: These are used: (a) In film printing to copy texture or grid effects into the sample pattern. (b) In photo-engraving for printing rollers to copy the Hatching into the negatives of the colour separations by contact printing.

Screen Frames: (film screen frames). The screen gauze is supported by the screen frame. Wood, metal, plastics and combinations of the above, e.g. metal/plastic, are suitable for the production of screen frames.

Screen Lacquer: This is used for prelacquering (preparation) in Screen making, as a support for photosensitive layers and as a reinforcement coating.

Screen Magazine For Printing: Screen magazines were placed to the side of or in front of the printing table in the first screen printing machines (Hikisch, Teximpex). They are divided into sections which can be raised and lowered in

order to bring the desired screen to printing table height. Before printing, the movable screen frame is removed from the screen magazine and is slid back into the same compartment afterwards.

Screen Making: After the printing repeat has been designed and the colour separation has been produced, a flat screen is manufactured using the photochemical method, or alternatively a rotary screen is manufactured using the galvano-plastic method (or less often using the photosensitive lacquer process). The carrier layer is formed by coating with gelatine, which contains ammonia and potassium dichromate. During exposure, the unexposed layers may continue to swell and can be rinsed out at a later stage. Nickel foil cylinders can also be patterned using Laser screen engraving. See **Engraving; Positive process for screen making.**

Screen Mesh: (Screen mesh, screen gauze), (a) Silk: elastic, insensitive to pressure and impact, durable, sensitive to strong alkalis; (b) Phosphor bronze (alloy consisting of 93% copper, 6.75% tin, 0.25% phosphorous): extremely fine wires (0.09–0.03 mm), high resistance to alkalis and acids, low elasticity gives high accuracy of registration, sensitive to pressure and impact (bulges); (c) Polyamide, polyester: fine, even and durable fabric, resistant to chemicals, low moisture absorption, sensitive to highly concentrated caustic soda solutions.

Screen Print: This term is used instead of Screen printing predominantly in the graphics industry. Screen print denotes the printing process in which the dye paste is pressed through the substrate as through a sieve.

Screen Printing: A screen resist is made by covering a frame with bolting cloth of silk, metal or nylon filament yarns. The fabric is covered with a film and the design areas are cut out of the film. Some areas of the mesh are left open to allow the dyestuff to pass through and print the fabric. The frame is laid on the fabric, and the dye is placed at one end of the frame. A rubber knife moves the dye across the screen and forces the dye through the open mesh of the fabric. One screen is prepared for each colour. Screen printing is considered by many textile authorities to be newest method of decorating fabrics.

Screen Printing Carriage: In principle, this is a rigid frame with four runners which are positioned in such a way that the frame can be raised vertically to a height of approx. 100 mm by operating levers. During printing the screen printing carriage is moved along the table with the screen until the repeat device locks into place. After this has engaged, the carriage and screen are lowered so the screen lies against the goods to be printed. After printing, the screen is lifted off again by operating the lever and the carriage is moved to the next repeat or the next repeat but one.

Screen Printing Machine, Automatic: These are machines which carry out the entire printing process automatically when the screens are fixed in a stationary position while the fabric moves.

Screen Printing Squeegees: See **Doctor blade; Squeegee systems in printing.**

Screen Printing Tables: The table, in hand screen printing, on which the item to be printed is affixed, whilst with screen printing machines, the endless printing blanket runs over the screen printing table, on which the piece good, with a backing cloth if necessary) is affixed. Wool felt is often used under the printing blanket as a flexible layer.

Screen Sequence in Screen Printing: Particular care should be taken with the sequence of screens or print pastes as this can have a major influence on the printing result, especially if fine outlines, overlaps or resists are being printed.

Screen Washing: As soon as printing operation is over the screens are to be washed to avoid choke (blocking of the perforations of the engraved portions in the screen due to the drying up of the paste) up of the perforations. This choke up is very difficult to remove. Hence the screens are washed in special screen washing equipments. The outer screen wall is cleaned using a spray ring, and the inside is cleaned with a spray head with jets. Another possibility is the turbo spray washer which is attached to the central wash water feed on the inside of the screen: there are polyamide fibres on the rotating part which are hydro extracted on the screen wall due to the rotating centrifugal force in order to mechanically intensify the washing effect of rinsing with water.

Screw Feeds: Feed systems in which the action of the screw generates pressure that causes flow. The system usually consists of a container with a closely fitting screw unit.

Screw melter: (1) Screw extruder in which frictional forces between the screw and the heated barrel contribute to rapid melting of solid polymer. This configuration is capable of high throughput. (2) System in which a screw feed is used to feed polymer to a melt grid and to maintain a constant pressure at the grid.

Scrim: See **Cheese cloth:** (1) A generic term for A lightweight, open-weave, coarse fabric; the best qualities are made with two-ply yarns. A low-quality plain-weave fabric of the muslin type with traditional cover factors for both warp and weft of about (2) It is very similar to cheese cloth. Normally used for backing other fabric such as fur. Cotton scrim usually comes in white, cream, or ecru and is used for window curtains and as backing for carpets. The mass

per unit area of the fabric will vary with the 35–70 g/m² when the fabric is made from cotton. (3) Fabric with open construction used as base fabric in the production of coated or laminated fabrics.

Scrimp roller: Also called Scroll roller. Rollers or bars (rails) characterized by grooves or projections inclined at equal and opposite angles to the centerline on each half of the rollers and used for removing folds or creases during finishing operations.

Scroll roller: See **Scrimp roller**.

Scroop: The sound of rustle or crunch that is characteristic of silk. Scroop is a natural property of silk, but may be induced in other fabrics to a degree by various treatments.

Scrooping agents: (1) Common as a finishing agent on fibres to produce specific finishing effects. Different types of scrooping agents are available to take into account water, fibre, type of fabric and intended use. Softening of textiles. (2) These are used to produce a scroopy handle (craquant, See **Silk scroop**). The textile fabric is treated with Marseilles soap, followed by an aftertreatment with lactic or tartaric acid. More recent methods are based on the use of ethoxylated fatty acids or paraffin emulsions.

Scutching: This is a mechanical operation which, by breaking and beating the retted flax straw, separates the textile fibres in the stem of the plant from the woody matter and the bark. The next step would be 'hackling'.

Sculptured: A term describing a carpet with areas of contrasting depth produced by mixing cut pile and loops.

Scutcher (Finishing): A machine for continuously opening fabric which has previously been in rope form. Automatic and manual machines are available for this.

Scutching: The process of running a fabric in the scutcher. See **Scutcher**.

Scutching (flax): (breaking). This is the first stage in Flax processing after retting and drying, and involves breaking down the brittle woody tissue into shavings. It can be carried out either manually or mechanically using a pair of fluted rollers. It is followed by the scutching process.

Scutching Tow: Is the by-product of the scutching of flax straw, often being rescutched; it is classified in Ireland as coarse, fine and rescutched; used for ropes.

Scye Depth, in body measurements: The distance from the cervicale to a point level with the armpit.

SDC: Society of Dyers and Colourists (British) Their web site is at www.sdc.org.uk.

SE: Silk (mulberry silk).

S.E.B. (Single-End Break), in sewing: Refers to the singleend breaking strength of the thread or tensile strength when stress is applied across a singlestrand of thread until it ruptures. S.E.B. is usually measured in pounds, ounces, or grams.

Sea Island cotton: The best quality cotton fibre in the world. It is strong, soft and smooth and made into top quality cotton yarn and fabrics in both plain and printed. Since the production is very limited the fabric made out of these fibres are very expensive.

Sea jute: A brown, brittle fibre composed principally of lignocellulose (Lignin) and similar to Peat fibres and being obtained from dead plant material on the Southern Australian coast, where it is obtained in great quantities. Used mainly for insulation and packing.

Sea Silk: Term applied to the strong lustrous fibres yielded by certain algae.

Sea Weed Fibres: yielded by species of algae; used for cordage, fishing lanes etc.

Seal: Black or grey in colour, the hair is shiny and flat with coarse texture; not hard wearing.

Seal Plush: Silk plush cloaking imitating real sealskin, the dyeing material is tipped on the ends of the pile, which has to be straight and slanting in only one direction.

Sealskin: Fur of the Alaskan seal, usually dyed black or brown. It is very hard wearing.

Sealskin Plush: (musquash). An imitation sealskin. Furlike plush consisting of a backing fabric with pile on one side, 3-5 mm thick, extremely lustrous, made from Tussah or Schappe silk, the cheaper grades also of cow hair; dyed in the piece in black to imitate real sealskin; used for coats.

Seam: A line where two or more pieces of fabrics are joined, usually near the edge. A seam is the line of sewing that joins two or more pieces of fabrics, usually near the edge; it may be plain or ornamental. The most important are the overhand, felled, French, slot, lapped, flannel, and beaded.

Seam, book/booking: The raw edge hem done on a blind stitch machine, usually sewn in the side and back seam outlets, and on the bottom turn-up.

Seam, French: A closure between two pieces of material, made by stitching, turning, and re-stitching so as to conceal all raw edges.

Seam, open gorge: Both the collar and the facing are turned under, basted, and then the seam is felled (edges folded together) from the outside.

Seam, raised: A seam resulting after two pieces of fabric have been joined; one piece is folded back, and a second row of stitching is placed adjacent to the folded edge.

Seam allowance, in sewn fabrics: The width of the fabric used in making the seam assembly bounded by the edge of the fabric and the furthest stitchline. (The distance from the edge of a fabric to the parallel stitchline furthest from the edge.)

Seam assembly: The composite structure obtained when fabric(s) are joined by means of a seam.

Seam busting: Pressure open seams, often carried out as an intermediate operation during garment assembly.

Seam damage, in sewn fabrics: A reduction in seam efficiency caused by a change in the physical condition of one more of the components in a seam.

Seam detector for jet dyeing machines: This is used for fabric control (monitoring the dyeing process), to stop the passage of the cloth (for sampling), to count the piece cycle and to determine the cycle time. The seam detector consists of a sampling probe, electronic kit and a display unit. As the sampling probe passes the jet pipe (secondary cradle mounting also possible), through which the goods are being transported in rope form in the liquor, the pre-marked seam (marked using a ferromagnetic body Ø 50 mm, 0.1 mm thick) causes the impulse which controls the passage of the goods and stops the piece circulation.

Seam efficiency, in sewn fabrics: The ratio, expressed as a percentage, of the breaking force required to rupture a sewn seam to that required to rupture the fabric.

Seam engineering, in sewn fabrics: The procedures used to select a specific combination of sewing thread, stitch type, seam type, and stitch density to achieve the maximum sewn seam strength for a particular fabric type.

Seam failure, in sewn fabric: That point at which an external force (a) rupture the sewing thread, (b) rupture the fabric, (c) causes excessive yarn slippage adjacent to the stitches, or (d) causes any combination of these unacceptable conditions.

Seam finish: A treatment of the raw fabric edges of the of the seam allowance in a plain seam.

Seam grin: Gaping of seam under stress usually due to inadequate thread tension at sewing.

Seam interaction, in sewn fabrics: The net effect of the relationship between the combination of fabric, seam type, stitch type and stitch density on seam efficiency.

Seam mark: Also called stitch mark. A particular form of pressure mark (q.v.) in a fabric, and that is produced by the relief print-off of defects such as slubs or seams joining lengths of fabric, under excessive rolling tension or by contraction on the roll during wet processing.

Seam mark, in finished fabric: A pressure mark caused by the thickness of the seam being pressed against the cloth. A defect consisting of separated yarns occurring when sewn fabrics pull apart at the seams. Seam slippage is more prone to occur in smooth-yarn fabrics produced from manufactured filament yarns.

Seam opening: See **Seam busting**.

Seam protection: If a fabric with a seam is passed through the cutting device of a shearing machine, the shearing blade will destroy the fabric along the seam. The cutting device therefore raises up from the shearing table (or preferably vice-versa). As the seam passes through, a seam protection plate automatically slides between the fabric and the cutting device and covers the shearing point until the seam has passed.

Seam pucker: Generally unwanted material waviness along the line of stitching.

Seam ripper: A tool used to undo the seams and removing stitches.

Seam, sewn: See **Sewn seam**.

Seam slippage, in sewn fabric: The partial or complete loss of seam integrity manifested by yarn slippage parallel to, or adjacent to the stitch line.

Seam slippage: The movement of warp and weft threads away from a seamline under traverse stress.

Seam smoothness, in fabrics: The visual impression of planarity of a seamed specimen quantified by comparison with a set of reference standards.

Seam type, in sewn fabrics: An alphanumeric designation relating to the essential characteristics of fabric positioning and rows of stitching in a specified sewn fabric seam.

Seam welding: Any stitchless procedure for joining fabrics based on the use of thermoplastic resins or the direct welding of thermoplastic materials. Seam welding is an alternative to conventional needle-and-thread seaming operations that is extremely popular in the nonwoven field.

Seam, bound: A seam having its material edges bound with a strip of additional material.

Seam, butt: A seam which is sewn with the two material edges abutting.

Seam, flat lock: A butt seam formed using a flatlock stitch.

Seam, french: A seam in which two pieces of material are superimposed, stitched together and then folded over and stitched again to conceal the edges thus producing a flat folded seam with only one row of stitching visible.

Seam, inserted: A seam in which a single or number of plies of material is inserted between two other which are turned in. The complete assembly is sewn in one operation.

Seam, Lap-Filled: A seam formed with the edges of both plies of material concealed by interlapping. Two or more rows of stitches secure the turned pieces of material.

Seam, Overlock: A seam in which two or more edges of material are joined together, oversewn and edge trimmed in one operation, with the overedge stitches having two or more threads.

Seam, Plain: A seam formed by a row or rows of stitches joining two pieces material together face-to-face.

Seam, Rolled: A seam where the two edges of the materials to be joined are rolled together and secured by a single row of stitching.

Seam, taped: A seam which includes straight tape. Normally used to prevent or control stretching and for strength.

Seam mark: A particular type of pressure mark in the finished fabric. It is produced during finishing operations by the thickness of the seam used to join pieces for processing. See **Stitch mark**.

Seaming: Joining the overlap of two pieces of fabric, usually near their edges.

Seamless: A term that describes a tubular knit fabric without seams, e.g., seamless hosiery.

Seamless Hose: Made on the circular knitting machine without any seam and in one width throughout the whole piece. It is shaped on drying boards.

Seamless Knitting: A unique process of circular knitting, done on either Santoni or Sangiacomo knitting machines. This circular knitting process essentially produces finished garments with no side seams, which require only minimal sewing to complete the garment. Seamless knitting can transform yarn into complete garments in a fraction of the time it takes for traditional garment manufacturing, by minimizing the traditional labor-intensive steps of setting and sewing.

Seamless Technology: This term can refer to either “seamless knitting” (See Seamless Knitting), or “welding/bonding technology”, which uses a bonding agent to attach two pieces of fabric together, and eliminates the need for sewing threads. (See **welding**.)

Seasonal ranges: Ranges produced for the different seasons Spring/Summer and Autumn/Winter. Mid-season ranges may also be produced.

Seat: Part of trousers or similar garments covering the buttocks.

Seat Angle: The quantity of material (5-8 cm.) allowed at the seat on the underside for ease of movement.

Sebastopol: Fine twilled woollen dress goods with very fine, different coloured narrow runs visible only when the fabric is draped.

Secant Modulus: The ratio of change in stress to change in strain between two points on a stress-strain diagram, particularly the points of zero stress and breaking stress.

Second Cuts: Flibs, or short lengths of wool resulting from cutting wool fibres twice in careless shearing. An excessive number of second cuts decreases the average fibre length, and depreciates spinning quality.

Secondary Backing, in pile yarn floor covering: A material adhered to the backing fabric side of a pile yarn floor covering.

Secondary Colours: Green, orange, and violet, each of which is obtained by mixing two primary colours. Orange is made by mixing equal amounts of red and yellow; green is an equal mix of yellow and blue; and violet is made of blue and red.

Secondary Creep: The nonrecoverable component of creep. (Also see **Delayed deformation**.)

Secondary sedimentation tank, s. settling tank, s. clarifier: Sedimentation tanks used after biological treatment of a wastewater to settle out the *biomass* that has formed in the biological reactor from the treated effluent. These tanks are also known as biomass separators, *activated sludge settling tanks* or *humus tanks* (when used after *trickling filters*). *Radial flow* tanks are common but *horizontal flow* tanks are also used. Tanks are typically 2.5 to 4 m deep and the *surface loading rate* is from 20 to 45m³ per day per m² of tank surface area. In small treatment works, *pyramidal sedimentation tanks*, or *pebble bed clarifiers* may be preferred. See *secondary sludge*, *solids surface loading rate*.

Secondary sludge: Sludge from secondary sedimentation tanks (return activated sludge or humus sludge). In temperate climates secondary sludge is often returned to the primary sedimentation tanks and is there thickened

to give a mixed sludge. In hot climates this may be unsuitable because the secondary sludge becomes anaerobic very quickly and rising sludge is seen in the primary tanks. Flotation may be better than sedimentation for secondary sludges in warm climates. *See* **sludge production**.

Secondary treatment: In wastewater treatment, the treatment process that follows *primary treatment*. It is used to remove the remaining organic solids that have not been removed in primary treatment together with the 90% or more of the dissolved organics. *Aerobic biological treatment* is commonly used. Secondary treatment may also incorporate *nitrification* and *biological phosphorus removal*.

Second-hand filling material: An industry product which contains any filling material which has previously been used should not be offered for sale unless a clear and conspicuous disclosure of that fact is made on the label thereof and in all advertising and invoices relating to such product.

Second-Order Transition Temperature: The temperature at which the noncrystalline (amorphous) portions of polymer melt or become plastic. An inflection point or change in stress-strain properties occurs at this point; however, for most fibres, this change is small.

Seconds: (1) Imperfect fabrics (woven or knitted) containing flaws in the weave, finish, or dyeing, and sold as "seconds." (2) *See* **Yarn quality**.

Section Beam: (1) A large, flanged roll upon which warp yarn is wound at the beam warper in preparation for slashing. (2) Small flanged or unflanged beams assembled side-by-side on the shaft of a warp beam for further processing.

Section blankets: *See* **Sample Blankets**.

Section draws: This division of drawing-in drafts is used extensively in all manufacturing; for instance, in all fabrics having a ground warp and a binder warp, also in double-face goods, or where two different weaves are combined in one effect. One or more threads are drawn on the first section, then one or more on a second and third, if the harness is divided in so many sets.

Section Mark, in woven fabrics: Warp bands of different colour, texture or lusture.

Section Mark: Warp stripes/bands of different colour or texture or both that occur at regular intervals across part or all of the fabric width as the result of tension variation in the sections during section warping (q.v.) or because of differential dyeability of the warp yarns.

Section number: Section number = Total no. of threads/Creel loading capacity. If the calculation does not give an exact number, the last section

will be produced with a number of threads lower than the other sections, or the number of threads composing each section will be reduced so as to get all sections with one and the same number of threads.

Section warping: See **Sectional warping**.

Sectional warp beams: are warp beams with protruding pegs that separate the beam into sections, usually 1–2" wide each. The warp is wound into each section separately.

Sectional Warping: The parallel winding of several warp threads to produce the warp beam. The yarn is stretched on large frames and guided through grid-like devices in such a way that the threads are wound parallel to one another on the warp beam. For particularly high warp settings and fine material, cone sectional warping machines are used. In sectional warping, it is important to achieve an absolutely uniform tension when winding the individual warp threads. See **Warping Yorkshire Warping, Scotch Warping and Silk-System Warping**.

Section width: Section width = Reed width/number of sections. This way the total number of warp threads will occupy on the dresser a width equal to the width of the weaver's beam on which they will be finally wound.

Sediment oxygen demand: The residual solids discharged with treated waste water will, in time, settle to the bottom of streams and rivers. Because the particles are largely organic, they can be decomposed anaerobically as well as aerobically, depending on conditions. Algae which settle to the bottom will also decomposed, but much more slowly. The oxygen consumed in the aerobic decomposition of material in the sediments represents another Dissolved Oxygen demand in the water body.

Sedimentation: The settling of a suspension, either under gravity or in a centrifuge. The speed of sedimentation can be used to estimate the average size of the particles. This technique is used with an ultracentrifuge to find the relative molecular masses of macromolecules.

Sedimentation tank, settling t.: An important treatment process in which the tank is used to settle out solid material from the water or wastewater. In water treatment, sedimentation tanks are used after *coagulation* and *flocculation* and are normally known as *clarifiers*. *Primary sedimentation* is common in the treatment of domestic wastewater after *screening* and *grit removal*. Sedimentation tanks are used after biological treatment of a wastewater to settle out the *biomass* that has formed in the biological reactor from the treated effluent. These tanks have various names, including *activated sludge settling tanks*, *biomass separators*, *humus tanks* or *secondary sedimentation*

tanks. Sedimentation tanks may be *horizontal flow*, *radial flow* or *upward flow*. They are often designed on *surface loading rate*. The performance of the tanks may be upgraded by the use of *inclined plate and tube settlers*. In wastewater treatment, a clarifier is synonymous with *sedimentation tank*. In sludge treatment, *gravity thickening* tanks are a type of sedimentation tank.

Sedjadeh: Turkish name for medium sized Oriental carpets.

Seed Coat Fragment, in cotton: A portion of a cotton seed, usually black or dark brown in colour, broken from a mature or immature seed, and to which fibres and linters may or may not be attached.

Seed Cotton: Cotton, as harvested and before ginning, consisting of seeds with the fibres attached and usually including measureable amounts of foreign matter.

Seed: Fruit wall hairs.

Seed hair fibres: Vegetable hair fibres, which can be found on the seed husks of various plants. These include Cotton and Akund.

Seeded: Small dots strewn over the face of the fabric; same as powdering.

Seedy Wool: Wool containing numerous seeds or an appreciable amount of vegetable matter.

Seerloop Gingham: Gingham with slack-tension loops of yarn on the surface, often on the white lines only.

Seersucker: Cotton crimp crêpe with vertical stripes, also Craquelé. A fabric with puckered stripes alternating with the flat ones of various widths only. Stripes may be multicoloured or in a plain coloured fabric with a printed floral pattern on it. A favourite summer fabric is made on twin beam loom, which feeds the yarns at different speeds and the ouckers are therefore woven in and



are more or less permanent. Normally made in cotton, polyester/cotton and even Nylon also. A good seersucker construction is 100×60 with 30s yarn in the warp and filling. In woven seersucker, finer yarn may be used in the coloured stripes than in the white stripes. Used for lightweight casual cloth

such as shirts, skirts, beachwear, aprons and for tablecloths and kitchen curtains. Creases do not show.

(2) From synthetic fibres, e.g. patterned interwoven, shrinkable synthetic spun yarns with different shrinkage properties. At increased temperatures, the high shrinkage material shrinks and creates the embossed design together with the more shrink-resistant adjacent material.

(3) Similar non-fast effects can also be obtained by local application of substances which cause the fibres to swell. When producing a garment made from Crêpe prepared by steeping in caustic soda, a resist print paste which contains a water repellent agent is overprinted in the direction of the warp (as the crêpe effect is only possible in the direction of the warp). The garment is then padded using caustic soda liquor. During this process, a distance of 1–1.5 m should be maintained between the trough and the padding roller so that the caustic soda solution can create a water repellent effect on the areas for resist printing.

Segovie: Very fine French serge, made of Spanish wool with a nap on the face.

SEK, SchEK: Swiss commission for fastness.

Self bonding fibres: Bicomponent fibres consisting of polymers with different melting points. If they are heated to the temperature corresponding to the fibre with the lowest melting point, this acts as an adhesive for the other components.

Self bound seam-finish: A durable seam finish which launders very well is a finish for the raw edges of the seam allowances of a plain seam, in which one seam allowance encloses both raw edges. Stitch a plain seam, right sides of the fabric together, press to lie flat. Trim one seam allowance to 3 mm. (1/8 in.) wide. Turn under the other seam allowance 3 mm. (1/8 in.) and press in a crisp fold. Turn the seam allowance over the trimmed edge. Press in a second fold so that the trimmed edge is encased. Edgestitch the seam allowances together as close to the seam line to the seamline of the garment as possible.

Self-Casing: A piece of fabric where the hem edge is folded over and neatened to create a tunnel. A drawstring or elastic is then threaded through the tunnel to draw up the fabric.

Self cross linker: In contrast to reactive resins, which tend to react more with cellulose and crosslink these, self-cross-linkers tend to react more with themselves and form resin deposits in the pores of the fibre which promote crease resistance. Self crosslinking resins.

Self crosslinking resins: Resin finishing agents which predominantly react with themselves under specific crosslinking conditions (self crosslinkers, self

crosslinking agents;), which therefore also only enter into low crosslinking reactions with cellulose (in contrast to Reactive resin) such as Urea and Melamine-formaldehyde compound. See **Cross-linkers**.

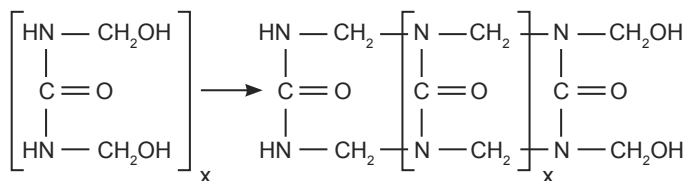

Resin forming self crosslinking mechanism in resin finishing.

Self-extinguishing: Term used in the Flammability test: after the ignition flame has been removed, the test fabric continues to burn for a short time, although the charred area does not increase significantly. The flame extinguishes itself, although there is still non-burned test fabric which could fuel the flame.

Self-goods: When the same material is used as a pocket lining, or in a waistband, collar and fly construction. Also called shell.

Self shade: (solid dyeing, plain dyeing). Monochromatism; occurs in fibre blends as Tone-in-tone dyeing.

Self smoothing fabric: Fabrics with an Anticrease finish.

Self stitching: See **Double stitching**.

Self twist spinning: A method of making a yarn from the roving fed to a drafting unit; the emerging strand of fibre is subjected to a cyclically reversing false twisting action which can be imparted in a number of ways. Two adjacent strands delivered from the false twist system are brought together by guides and the torque in the two strands causes them to wrap about each other. This wrapping action is defined as 'self twist' and produces a self twist pattern of -S-Zero-S-Zero- etc. in the yarn produced. The self twist yarn is then taken up as a cheese. Note: Further twisting may be necessary before this yarn can be used.

Self twist twisted (STT) yarn: A self twist yarn to which unidirectional twist has been added in a subsequent operation.

Self-bonding fibres: Bicomponent fibres consisting of polymers with different melting points. If they are heated to the temperature corresponding to the fibre with the lowest melting point, this acts as an adhesive for the other components.

Self-bound seam finish: A finish for the raw edges of the seam allowances of a plain seam, in which one seam allowance encloses both edges.

Self-cleaning: Rotating filter basket with a rinsing self-cleaning effect to discharge any lint present.

Self-extinguishing: Not defined; ASTM has a ban on this term in their standards. It has no meaning except in association with a specific test method or specific conditions of burning.

Self-fil yarn: This is a single yarn consisting of fibre slubbing (e.g. wool) and two fine synthetic filament threads which loop in alternating directions offset phase around the yarn compound which has been subsequently formed, and thus has the effect of strengthening the yarn.

Self-twist yarn: An inherently twist-stable, two-ply structure having a ply twist that is alternately S- and Z-directed along the yarn.

Selling price: The price the product is sold at.

Selvage: Same as Selvedge. See **Selvedge**.

Selvedge or Selvage: The narrow edge of woven fabric that runs parallel to the warp. It is made with stronger yarns in a tighter construction than the body of the fabric to prevent raveling. A fast selvage encloses all or part of the picks, and a selvage is not fast when the filling threads are cut at the fabric edge after every pick.

Selvedge cutting device: This is a device which is used to cut the selvages and remove the edge waste.

Selvedge feeler: Non-contact scanning device which operates mechanically or photoelectrically to guide the cloth, particularly on stenters.

Selvedge gassing machine: This is used to remove loose threads on the selvage by gas singeing.

Selvedge guider: An electronic or mechanical device for presenting fabric straight to stenter pins or clips.

Selvedge mark: A more or less regular mark in the finished cloth along the selvage produced by folded or doubled selvage during the finishing operation.

Selvage mark, in finished fabrics: A lengthwise crease mark along the selvage caused by an edge being folded or doubled.

Selvedge monitor: This is a safety device which switches the machine off if one or both of the selvages is no longer held by clips or the needle bar.

Selvedge printing machines: (selvedge printers). These are generally combined with inspection machines on measuring machines, or less commonly with fabric batching machines. Company logos or advertising slogans are printed on the selvages using heat transfer printing units.

Selvage or Selvedge: The thin compressed edge of a woven fabric which runs parallel to the warp yarns and prevents raveling. It is usually woven, utilizing tougher yarns and a tighter construction than the rest of the fabric.

Selvage uncurler: A device for straightening selvages and fabric edges which have rolled during processing or other ways.

Selvedge: The longitudinal edges of a fabric that are formed during weaving with the weft not only turning at the edges but also passing continuously across the width of the fabric from edge.

Note: Selvages are often up to 20mm wide and may differ from the body of the fabric in construction or weave or both, or they may be of exactly the same construction as the body of the fabric and be separated from it by yarns of a different colour. Although selvages may contain fancy effects or may have brand names or fabric descriptions woven into or printed on them, their main purpose is to give strength to the edges of the fabric so that it will behave satisfactorily in weaving and subsequent processes. (a) Leno Edge A set of threads that interlace with a leno weave (q.v.) either at the edge or in the body of a fabric. In the latter case, it prevents fraying when the fabric is severed in the direction of the warp.

Note: When in the body of the fabric, a leno edge is often referred to as a “central selvedge”.

(b) Sealed Edge. The cut edge of a fabric that has been treated by heat or chemical means to prevent fraying of the edge.

(c) Shuttleless-Loom Edge.

(i) In some cases, either one or both edges are different from the normal woven selvedge in that the weft is held in position at the turn by threads other than the warp threads, e.g. by the use of an independent thread to lock the weft in position at the edge, or by interlocking of the weft threads. In narrow-fabric weaving this type of edge is often called a “needle loom selvedge”.

(ii) In other cases, the weft is severed just beyond the edge of the fabric and the cut end is tucked into the shed (q.v.) formed on the next pick.

Selvedge, jacquard: A selvedge that has a jacquard-woven pattern or lettering.

Selvedge cutting device: This is a device which is used to cut the selvages and remove the edge waste.

Selvedge feeler: Non-contact scanning device which operates mechanically or photoelectrically to guide the cloth, particularly on stenters.

Selvedge gassing machine: This is used to remove loose threads on the selvedge by gas singeing.

Selvedge guider: See **Expander**.

Selvedge mark, in finished cloth: A lengthwise crease mark along the sledge caused by an edge being folded or doubled.

Selvedge monitor: This is a safety device which switches the machine off if one or both of the selvages is no longer held by clips or the needle bar.

Selvedge trimming Machine: See **Selvedge cutting device**. This is used to remove from the selvages loose, overhanging nonbound selvedge trailers which occur in weaving. The thread ends are cut off using a special shearing tool and extracted.

Selvedge uncurler: (scrollers). This is a device to uncurl, unfold and stretch fabric and knitwear selvages which have been rolled or turned up.

Selvedge unroller: These are used to open, unroll and stretch surface sensitive woven and knitwear with folded edges or rolled selvages.

Selvedge, tight: A continuous filament thread that has lost some of its filaments, usually as a result of abrasion or excessive tension during winding or weft insertion and that appears as a thin yarn.

Selvedge printing machine: (selvedge printers). These are generally combined with inspection machines on measuring machines, or less commonly with fabric batching machines. Company logos or advertising slogans are printed on the selvages using heat transfer printing units.

Selvyt: An unfinished velvet, made of harsh cotton, used for polishing cloth.

Semal: Cotton Silky fibre yielded by the Indian bombax malabaricum. It is straight and flattened and used for stuffing.

Seme: French for powderings or small patterns over the ground of the cloth, lace, etc.

Semi-automatic: Certain machine work stages are initiated manually but run automatically. Only part of the processes are automatic.

Semi-bright Wool: Grease wool that lacks brightness due to the environment under which it is produced, though it is white after scouring.

Semi-broad cloth: See **Broad cloth**.

Semi-collapsed balloon spinning: A system of ring spinning in which the rotating yarn balloon is eliminated at the start of an empty bobbin and is allowed to expand later when the bobbin is becoming filled with yarn. The small-balloon condition is achieved by allowing contact between the rotating balloon and spinning top. As the bobbin fills contact is broken and the yarn balloon is allowed to reform. Note (a): The system is often used for worsted and semi-worsted spinning. Note (b): Special spindle top extension are used to obtain the required effect.

Semi-continuous bleach: Open-width boiling and bleaching process for larger batches of cotton and cotton/ synthetic blends which are uneconomical for continuous plants. Device: impregnating device, Benteler batching device and open-width scouring machine.

Semi-continuous systems: In these mixed systems several operations are carried out with both continuous and discontinuous machines. For example, a continuous pad-batch machine is used to wet the fabric and a discontinuous system is then used for other treatments. These mixed systems are suitable for processing small and medium lots; they require reasonable start-up costs and grant quite good reproducibility.

Semi-decating: Semi-decating is a batch process requiring three steps: (a) Winding the fabric onto a perforated cylinder between a cotton decating apron, (b) Steaming and followed by cooling the fabric and (c) Unwinding and batching the finished fabric. Proper pressure, heat, moisture, cooling and time are prerequisites for quality results. The procedure requires that the fabric be wound onto a perforated drum between the interleaving cotton decating apron to form a reasonably thick roll. Steam is forced through the roll (inside - out) for several minutes to provide moisture and heat. Compressed air is then blown through the roll in much the same manner as the steam to remove some of the moisture and cool down the fabric. To insure that the effect is uniform from the inside to the outside of the roll, the fabric and blanket are rewound onto another perforated drum so that the outside layers become the inside layers and the cycle is repeated. At the end of the cycle, the fabric and blanket are separated and wound into individual rolls.

Semi-decatizing: See **Semi Decating.**

Semi-felting raising machine: Wire raising machine which guides the napping cylinder in the opposite direction to that of the direction of the cloth by moment reversal.

Semi-permeable membrane: A membrane that, when separating a solution from a pure solvent, permits the solvent molecules to pass through it but does not allow the transfer of solute molecules. Synthetic semipermeable membranes are generally supported on a porous material, such as unglazed porcelain or fine wire screens, and are commonly formed of cellulose or related materials. They are used in osmotic studies, gas separations, reverse osmosis water systems for homes and beverage industries, and in medical applications.

Equilibrium is reached at a semipermeable membrane if the chemical potentials on both sides become identical; migration of solvent molecules towards the solution is an attempt by the system to reach equilibrium. The pressure required to halt this migration is the Osmotic pressure.

Semi-pigmentation process for vat dyes: Principle: the dyebath is prepared cold with finely dispersed dyestuff, alkali and sodium dithionite and then heated slowly to vatting temperature, if necessary later to temperatures above 100°C (HT process) after reducing agents have been added.

Semi-restraint: Of or relating to a method of mounting that allows an object a limited degree of movement (for example , contraction or expansion of a fabric).

Semi suppressed balloon Spinning: See **Semi collapsed Balloon spinning.**

Semi-combed yarn: A cotton yarn made from slivers that do not have all the nails removed.

Semi-worsted spun: A term applied to yarn spun from sliver produced by carding and gilling in which the fibres are substantially parallel, the carded sliver not having been condensed or combed. Alternately, the yarn may be produced from a roving. Note: the above definition is descriptive of processing technique and not fibre content.

Semipermeable: This refers to the characteristic of a membrane which is permeable to specific molecules or ions, and to be impermeable to others. See **Osmotic pressure; Diffusion.**

Semi-poplin: See **Poplin.**

Semi-suppressed balloon spinning: See **Semi-collapsed balloon spinning.**

Semi-worsted yarn: (a) This refers to soft, full-bodied yarn, loosely or tightly twisted, produced in the semi-worsted spinning process for weaving, knitting, warp-knitting. Intermediate stage between Worsted yarn and Carded yarn. Is fuller bodied, but less strong than worsted yarn, as the short fibres are not separated using combs. Semi worsted yarn is stronger, but less full-bodied than carded yarn, on the other hand; clear finish. II. Fabric with a) a worsted warp and a carded weft or (b) twisted carded and worsted yarn, in the warp and the weft or (c) alternate worsted and carded yarns in the warp and the weft.

Semi-volie: See **Voile.**

Semiyoung: Black coloured Chinese velvet with cotton filling.

Sequestration: The formation of a complex with an ion in solution, so that the ion does not have its normal activity. Sequestering agents are often chelating agents.

Senegal gum: African Vegetable gums with predominant acacia content. Properties similar to those of kordofan gum, described under Gum arabic, but with less adhesive strength. Main varieties: poorest qualities: pador gum,

(dark amber to brown, often contaminated with sand and vegetable matter). Galam gums are purer and more water-soluble. The best qualities are found in salabreda gums which can be ground (most similar to kordofan, the purest form, colourless or slightly coloured).

Sengfangtchen: Chinese silk taffeta, white or ecru, with a 'finish; about 20 inches wide. The texture is very 'fine and regular. Used for drapery, painting, etc.

Senna Knot: One of the two kinds of knots found in hand-made Oriental pile carpets. A complete loop is formed by the yarn, thus having a pile extending from every space between the warp threads, thus making more knots and a denser and even pile than the Ghiordes knot.

Senneh carpets: (Senna carpets). The finest and most well-known Knotted carpets from Iran. Extraordinarily finely linked patterning in finely graduated, modest colours. 250,000–600,000 Turkish knots/m².

Senna Rugs: Very fine Persian rugs made in small sizes, usually with cotton web and very close and short wool pile tied in Senna knots. The design consists usually of small patterns covering the entire field or of a lozenge center medallion. White, red and blue are used the oftenest. Very fine khilims (see) are also made in the same design and colouring.

Separate element Zipper: A zipper consisting of two series of separately formed elements, each attached to one of the opposing edges of two tapes, which are engaged and disengaged by the movement of a slider.

Seperable Pin In Zipper: A tube like element attached over the bead at the bottom end of one striner.

Seperable Zipper: A zipper fitted with special components at the bottom of the chain, so as to complete disengagement and then reengagement of the two stringers.

Separator: A component of some open-end spinning machine located inside the rotor to direct the incoming fibres to the slide surface.

Sequencing batch reactor, SBR: A wastewater treatment that consists of a sequence of different cycles in a reactor, but flow neither enters nor leaves the reactor until the treatment is completed, i.e. it operates on a fill and draw. An example of biological treatment in a SBR for the removal of BOD and nitrification. Other cycles can be added, for example, after filling, the next sequences can be mixed anaerobic conditions, followed by anoxic conditions, followed by aerobic conditions in order to obtain *biological phosphorus removal*. The next sequence would be sedimentation allowing discharge of the effluent. The final sequence would be the inflow of more wastewater that

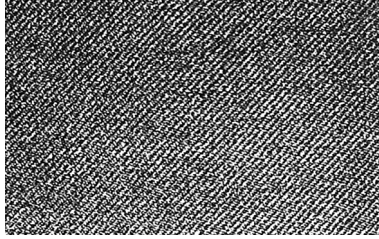

56 in. width. Serge is also made with 2/32s warp and 16s filling. Most serge is made with 2/2 twill weave. Serge usually dyed in Navy and Olive (for army) shades but sometimes made from stock dyed yarns. This fabric is an old favourite for semiformal for farmers.

Serge weave: Same as **Twill weave**.

Serge, double: It is constructed of two warps and two fillings. The weight runs from 12–20 oz. per yard.

Serge, French: It is a very high type of dress goods with a fine, lofty, springy feel. French serge is superior the average run of serge; the warp may be single or two ply worsted, filling is usually single worsted. The weight run from 6 to 10 oz. per yard and the fabric is usually piece dyed. Usually used for suits for ladies.

Serge, French-back: It is a men's wear of two warps and one filling. It runs from 16–18 oz. per yard in weight and was formerly used in winter suitings.

Serge, storm: This fabric is lower in texture than normal serge, but heavier. Usually made with 2/2 twill weave. Made from poorer grade stock, it has lustre and its harsh and wiry to the feel. Used as a protective outer wear like storm jackets, hence the name.

Serge d'Aumale: (1) XVIII century French serge, the warp made of slack twist woollen yarn and the filling of harder twisted single wool yarn; (2) Narrow and light French serge, used for lining.

Serge de Berry: In the 19th century a worsted in England, similar to lasting but heavier and woven with seven harnesses.

Serge de Blicourt: 18th century French wool serge made of slack twist warp and harder twisted single filling.

Serge de Boys: 17th-century English Worsted.

Serge Cloth: English woollen serge of smooth face and napped back.

Serge Denim: An 18th century pure worsted fabric in England. Believed to be same as serge de Nismes.

Serge de Rome: Piece dyed mostly black fine French serge, made of two-ply warp and very slack twist filling with 8-ends and four picks in a repeat. Made with or without double face. Also made of silk.

Serge De Nimmes: A coarse cotton fabric produced during the last century in Provence. Denim fabric for jeanswear; sail cloth trouser fabric, warp printed in indigo, originally white or brown. Specially sewn and riveted garments which are artificially aged (stonewash; sandblasted, biowash process). First jeans manufacturers to use serge de Nîmes: Lewis, Lee, Wrangler.

SerGING: (1) Overcasting the cut edge of a fabric to prevent raveling. (2) Finishing the edge of a carpet by over-sewing rather than binding. Generally, the sides of a carpet are serged and the ends bound.

Sericin: Silk gum. The gelatinous protein that cements the fibroin filaments in a silk fibre which accounts about 19-28% of the raw silk. It is removed in the process called degumming. Composition: 45% carbon, 32% oxygen, 17% nitrogen, 6.5% water. Sericin has a different amino acid structure to that of fibroin (Silk structure, see Tab.), i.e. basic and particularly acid groups in higher concentration (aspartic acid, glutamic acid, serine, threonine, tyrosine). Its isoelectric point is therefore pH 4.1, whereas that of fibroin is pH 4.9.

Sericulture: Rearing of silk worm and producing cocoon, including growing mulberry leaves for their food etc. all together is called sericulture.

Serpentine Twill: A twill weave made in wavy ridges.

Serpilliere: The coarsest grade of unbleached, loosely woven French canvas, made of hemp tow; used for bagging.

Served Yarn: In aerospace textiles, a reinforcing yarn such as graphite or glass around which two different yarns are wound, i.e., one in the Z direction and one in the S direction, etc., for protection or compaction of the yarn bundle.

Set: The number of threads found in the fabric within an inch width. In Bradford the number showing how often a beer (40 threads) is found within a width of 36 inches.

Set Checks: Large checks of the same colours are set at certain distance, forming the characteristic feature of the fabric, with other colours between.

Set Mark: A fabric defect consisting of narrow bars or bands across the full width of the fabric that may appear either as a tight, loose, or corduroy effect caused by loom stops improperly reset by the weaver. Set marks are sometimes caused by the weaver ripping out filling yarn and then not properly adjusting the pick wheel to obtain the proper relation between the fell of the cloth and the reed.

Set Point: An input in process control that defines the desired value or range of values of the variable that is being controlled.

Set Yarns: False-twist yarns stabilized to produce bulk.

Sett, in woven fabrics: The number of warp and weft yarns in fabrics (the number of stitches in knitwear) per unit of measurement, i.e. per 1 or 10 cm, often per cm². Magnifying glasses or yarn counters are used to determine the sett. The sett therefore corresponds to the distance from the centre of one yarn to another. Whether the yarns lie closely together or form open stitches is insignificant. Not to be confused with fabric density.

Sett: The warp **sett** is the number of warp ends per inch—usually abbreviated as **epi**. The weft sett is the number of weft picks per inch—usually abbreviated as **ppi**.

Setting: The process of conferring dimensional stability on fibres, yarns or fabrics, generally by means of moist or dry heat. The operation of setting is applied to textile materials of all kinds but assumes special significance in the treatment of synthetic-polymer materials such as nylon, polyester, etc.

Sew: To unite or fasten with stitches made with needle and thread.

Sew together: In order to pass large batches made up of a number of pieces efficiently through the production process of textile finishing, the individual pieces are sewn together. This is carried out on an industrial sewing machine.

Sewability: Ability to sew without skipped stitches or having the thread break. Several factors effect sew ability: improper needle size, wrong thread size, excessive tension, needle heat, worn or defective sewing machine parts, and improper machine settings. Thread likewise plays a key role in sew ability. Factors in thread sew ability include elongation, uniformity, ply security, lubrication, strength, and twist construction.

Sewing force: The force applied to a sewing thread at the needle eye during the penetration of the material by the needle.

Sewing hems: In sewing the hem, the needle should take up only the edge to be hemmed down and just enough to hold on the cloth or lining. In white work the stitches should be fine, showing as little as possible.

Sewing hole, Button: A hole in either the flange or shank used to attach the button to the substrate by means of a needle and thread.

Sewing machine, in sewing: A machine that uses needles and bobbin threads in stitch formation and is primarily for home sewing use rather than industrial use.

Sewing out: Sewing parts of a garment together with the raw edges turned in.

Sewing round: Sewing round the edges of a coat to join the outer material to the facing or the facing and lining.

Sewing Silk: Made of from three to 24 reeled cocoon filaments, twisted together slack in groups of left hand twist and twisted in the reverse direction under tension.

Sewing thread: A flexible small diameter yarn or strand, usually treated with a surface coating lubricant, or both intended to be used to stitch one or more pieces of material or an object to a material.

Sewing thread: See **Thread, sewing.**

Sewing thread lubricant: Due to the increased demand for sewing threads made from synthetic fibres and the use of higher sewing speeds in industrial applications, sewing thread lubricants based on simple organic substances such as waxes or stearates are no longer sufficient to control the development of heat in the sewing needle, i.e. to provide a heat shield. For high sewing speeds, silicone-based products have been found to be particularly suitable.

Sew-through flange button: A button that has two or more holes in its flange for passage of a needle and thread so that the button can be attached to a flexible substrate.

Sew-knit fabric: An alternative turn for stitch-bonded fabric.

Sewn seam, in sewn fabrics: A juncture at which two or more separate plies of material or materials of planar structure such as textile fabrics are joined by sewing, usually near the edge.

Sewn seam strength, in sewn fabrics: The maximum resistance to rupture of the junction formed by stitching together two or more planar structures.

Sew-though flange Button: The button that has two or more holes in its flange for passage of a needle and thread so that the button can be attached to the flexible substrate.

Sew-through shank button: A button attached to one part of a flexible substrate by means of needle and thread passed through a hole or loop in the integral shank and through the substrate.

Seydel converter: Tow-to-top processing equipment. Seydel combines the prestretching and breaking process in one machine.

S-finishing: See **S Finish.**

SFR: Swedish Association of Textile Engineers and Colourists.

SFS: Finnish Standards Organization.

Shade: A common term loosely used to describe broadly a particular colour or depth, e.g. pale shade, 2% shade, mode shade, fashion shade.

Shade (v): To bring about, in dyeing, relatively small modifications in the colour of a substrate by adding further small amounts of dye, especially with the object of obtaining a more accurate match with a required pattern or colour.

Shade Bar: See **Bar**; **Mixed weft**; **Mixed filling**.

Shade Buildup: (1) The increase of depth of shade during the dyeing. To achieve a uniform shade build-up in dyeing, combinations of dyes having similar rates of exhaustion should be used so that they will be taken up by the fibre as uniformly as possible in a specified period of time over a specified rise in temperature. (2) Dyeing of polyamide or acrylic fibres with dyes or dye combinations at increasing concentrations. The purpose here is to establish the depth of shade which corresponds to the maximum build up of the particular dye or combination.

Shade Change: Change of colour in any process or a wash fastness test. During a fastness checking there can be a depth difference in the shade and a tonal change. The shade change is graded with the help of a grey scale for shade change and the tonal change is indicated by a letter in brackets along with the grading number. For example a test result is graded as 3 and a tonal change to redder is shown as 3(R).

Shade of colour: (1) (position in colour space). (2) (dyeing) Colour.

Shade number: The number allocated to each of the 24 hues in the Chromatic circle.

Shade reproducibility: The possibility of achieving exact reproducibility of shade from the same dyeing recipe. In practice, two main problems influence shade reproducibility: on the one hand, poor reproducibility may be due to errors in weighing out the dyes specified in the recipe or inaccurate volume metering on the other. Moreover, variations in substrate pretreatment or the quality and/or source of the substrate itself can also influence shade reproducibility.

Shade variation: A coloristic term for a difference in colour (usually between a particular batch and a standard) which can also be expressed numerically by means of computer colour measurement, ΔE .

Shaded Filling: A defect consisting of a bar running across the fabric caused by a difference in appearance of the filling yarn, and occurring at a quill change or knot.

Shading: In cut-pile fabrics, an apparent change in colour when the pile is bent, caused by differences in the way light is reflected off the bent fibres. This phenomenon is a characteristic of pile fabrics, not a defect.

Shading: A side-to-side change in colour across the width of a fabric.

Shading, in carpet: See **Pile reversal**.

Shading, In Carpet: A change in the appearance of a textile floor covering owing to a difference in light reflection because of localized alteration in the orientation of the fibres, tufts or loops. Shading can occur as temporary shading, permanent shading or tracking.

Shading, Permanent: (in carpet). An irreversible localized change in orientation of the pile of textile floor covering (sometimes known as water marking, pooling, or pile reversal). See also Shading in carpet.

Shading, temporary: (in carpet) A reversible localized change in orientation described as a normal characteristic of certain cut pile floor coverings. See also Shading in carpet.

Shadow Embroidery: Shadow embroidery is worked on the wrong side of thin material, using the cat stitch. The outline of the design only shows on the right side, the body of the design being seen dimly through the material.

Shadow Lace: The density of the stitch forms the pattern in this type of machine-made lace. There is no outlining thread to make the design stand out. It is light and flimsy and is used for blouses, evening dresses, etc.

Shaft: (1) A term often used with reference to satins indicating the number of harnesses employed to produce the weave. (2) See **Harness**.

Shaft Mark: A fabric defect characterized by a number of floating ends, usually caused by a broken harness strap on the loom.

Shafty Wool: Strong, dense and well grown wool with good length and spinning characteristics.

Shag Carpet: A loosely tufted carpet construction with cut pile 1 to 5 inches in length and with greater than normal spacing between tufts.

Sham: A fabric covering for a bed pillow, usually of decorative fabric that matches the bed covering.

Shampoo, in cleaning of textiles: A solution of detergent in water formulated for specialized cleaning tasks.

Shank Eye, in Button: The hole or loop in the shank of a sew-through shank button or the hole in the loop of staple of a staple button.

Shank, in Button: That part positioned perpendicular to and at the centre back of the flange, and having a hole or loop for use in attaching the button to one part of a flexible substrate by means of a needle or thread, a ring, or a toggle.

Shantung: Shantung derives its name from the Chinese province where it originated. A rough plain weave silk fabric made of uneven yarns which gives

the material an irregular textured appearance due to the use of thicker yarns or long slubs in the weft. Originally made from wild (tussah) silk on hand looms in the Shandong (Shantung) province of China. Nowadays it may be produced from (a) pure silk, in which case the yarns retain all knots, slubs and other imperfections, (b) synthetic fibres or (c) cotton. An imitation silk shantung has also been produced using lower quality bourette silk. A usual texture ranges from 90×50 to 160×60 . It is usually made in 40 – 45 in. wide with 75 to 150 denier rayon or acetate in the filling. In usual practice if acetate is used in the warp, rayon is used in the weft, or vice versa. Average weight will be around 5 oz. per sq. yard. Plain is normally used. A light fabric with a nep structure in the weft; The effect is called 'Shantunn', the name applied to this typical woven fabric, which today is found on the market in practically all fibres like rayon, nylon, acetate etc.

Shape memory: The ability of a garment or other textile article to hold its manufactured shape as a result of durable-press finishing. These materials are able to recover their original set shape again after changes induced by e.g. laundering, since the resin finish is only cured after the fabric has been made up into the final shape of the garment.

Shaped Facing: A garment is finished with a piece of fabric, with seam allowance, that mirrors the garment shape. This example shows the inside of an armhole.

Sharps needles: Fine, medium length hand sewing needles most commonly used for hand sewing and are also used in fine hand embroidery. They range in size from 5 to 12.

Sharkskin: Made from worsted yarn, this is an expensive fabric in fancy or novelty weaves, sometimes mixing colours. It is of fine texture and very hard wearing. Acetate or Viscose Sharkskin is used for sportswear. It is crisp and washes well. Needs to be ironed carefully to avoid shine. Occasionally made in silk also. Worsted sharkskin is woven in a 2/2 colour effect twill, with a texture similar to serge. A texture around 70×60 with 2/36s worsted yarn in the warp and weft may be considered characteristic. The colour arrangement is usually 1 white, 1 black or coloured, 1 white and so on in both warp and filling. Usual width 56 in.

Sharkskin, warp knitted: It is more rigid and more stable in a lengthwise direction than satin fabric due to shorter underlap movement of the front guide bar. The technical back of the fabric is rough due to short underlap movement of the front guide bar.

Shaatzneez: A fabric mentioned in the Bible, made of wool and linen.

Shabnam: Indian name of a plain, next to the finest grade of Dacca muslin.

Shaded Twills: Twill weaves made in diagonals with increasing or decreasing floats. They are called single or double shaded, according to the diagonals being shaded in one or two directions.

Shadow Check: Patterns produced on various, always solid coloured goods by using right hand twist and left hand twist yarns both for the warp and the filling; stripe patterns are produced by using these two yarns only in the warp or in the filling.

Shadow Lace: Very light machine-made laces, having a mesh ground and shadow like patterns in closer mesh.

Shafts, in weaving: are the frames that hold the heddles. When a shaft is raised or lowered, all of the warp ends threaded through the heddles on that shaft are raised or lowered. (Harness is sometimes used as a synonym for shaft, although originally it was the name for the mounting that holds all of the shafts.)

Shaker Flannel: Soft, well napped white flannel, woollen with cotton warp and woollen filling; used for underwear.

Sham Plush: Made by raising a long nap from a twilled fabric, to imitate pile, or by using chenille filling.

Shamrock Lawn: Lightweight union fabric composed of cotton and linen.

Shanking: Very coarse and short merino clothing wool taken from the legs.

Shappe: Spun silk in Europe, which is partly degummed by fermentation.

Sharak: Arabic term for gray, bleached or dyed doriahs (see) used for outer garments by the natives in Egypt; originally it was made on hand looms.

Shark Skin: (1) A glossy waterproof cloth, used for raincoats.

(2) Rayon (acetate), synthetics, particularly Arnel. Worsted. Made in plain or twill (2 up 2 down). Has a heavy, semi-crisp texture. It is very smooth and slippery. Has a flat look. It is mostly made in white but some also comes coloured. It wears well and launders well particularly in Arnel. Has a tendency to turn yellow with age, but the Arnel remains pure white. Uses: All kinds of summer wear. Dresses, suits, and coats. Used extensively for sportswear, for men, women and children

Shash: (1) In the Bible means cotton; (2) A fine cotton muslin in Arabia; (3) Native East African name for a very thin, bleached cotton muslin.

Shawl: Originated in Cashmere, where it was made of pashmina. Some of the best grades are still being made in India on hand looms, the patterns are being embroidered into the ground.

The best French shawls and the Paisley shawls, made in imitation of these Oriental fabrics, are woven on power looms but the pattern is only on one side of the shawl. Other shawls are crocheted or knitted by hand or by the machine.

Shear rate: See **Rheology**.

Shear strength: The resistance to forces that cause, or tend to cause, two contiguous parts of a body to slide relatively to each other in a direction parallel to their contact.

Shear Strength, in carpet: Ability of adhesive to resist splitting.

Shear, to: Trimming the pile loops of knitted plush fabrics by Shearing.

Shearing: A dry finishing operation in which projecting fibres are mechanically cut or trimmed from the face of the fabric. Woollen and worsted fabrics are almost always sheared. Shearing is also widely employed on other fabrics, especially on napped and pile fabrics where the amount varies according to the desired height of the nap or pile. For flat-finished fabrics such as gabardine, a very close shearing is given.

Shearing blade: A metal cylinder with 12–18 helical knife blades around its circumference is one of the key elements of a shearing machine (Shearing). The milled cut of the cutting blades produces an oblique shearing action so that any lateral yielding of pile fibres can no longer occur.

Shearing brush: A brush roller to prepare the fabric pile for shearing. A brush with a fabric adjusting device in front of each shearing cylinder to achieve optimum alignment of the fibres for shearing, i.e. a pile laying brush.

Shearing Machine: (cropping machine) Shearing is carried out with one or several shearing cylinders accommodated one behind the other in older shearing machines or cylinders mounted one above the other in the modern machines.

Shearing range: A production line consisting of several shearing machines arranged one after the other for continuous Shearing. This is a much more productive alternative than the batchwise shearing of fabrics which would otherwise require several passages on a single machine.

Sheath in feathers: A covering at the quill point end of nestling feathers or nestling down which holds the barbs together.

Sheath Core fibres: Bicomponent fibres of either two polymer types, or two variants of the same polymer. One polymer forms a core and the other surrounds it as a sheath.

Sheath, in feathers: A covering at the quill point end of nestling feathers or nestling down which holds the barbs together.

Sheath-Core: A descriptive term for a multicomponent textile fibre consisting of a continuous envelope which encases a continuous, central, internal region.

Shed: The opening formed when the warp threads are separated in the operation of weaving. See **Warp shed**.

Shed: The opening formed when the warp threads are separated in the operation of weaving. See **Warp shed**.

Shedding: The first of the three basic motions in weaving, in which a shed is formed, by separating the warp into two layers.

Sheen gabardine: Gaberdine where a particularly fine twill line is used in a variety of cloth are called sheen gabardine. This may be made of 24s worsted warp and filing, with a 100×56 construction and with a $3/2$ 63 in. twill weave. Average weight will be 12 oz. Sheen gabardines are quite similar to sateens.

Sheep's wool: The fibrous covering of a sheep classified according to breed and origin (region of cultivation). According to some standards, only the Wool from sheep may be described as wool. Wool that is shorn from sheep bred exclusively for wool production represents a more or less coherent Fleece.

Sheepskin: This is the skin of the sheep or goat with the wool left on. It can be made with the wool on the outside or inside. A suede finish is usually applied to the shin side.

Sheer: (1) Made of any fibre mostly plain but could be various weaves. Any very light-weight fabric (e.g. chiffon, georgette, voile, sheer crepe). Usually has an open weave. They mostly feel cool. Triple Sheers Heavier and flatter than sheers. Almost opaque. Many are made from "Bemberg", which wears, drapes, and washes well. Sheers are used extensively for after 5 wear, as well as afternoon dresses in heavier weights, and some coats, lingerie, curtains, trims, etc. A fabric that is transparently thin or diaphanous.

(2) A warm fabric that is transparently thin or diaphanous such as chiffon, batiste, net, Organdie and voile.

Sheer velvet: See **Velvet**.

Sheers: Transparent, lightweight fabrics of different constructions and yarns, especially those of silk and manufactured fibres. Examples are chiffons, some crepes, georgette, and voile.

Sheet blanket: A thin blanket of cotton or cotton and synthetic blend having a nap on both sides.

Sheet Cast Button: A button fabricated from a cast sheet of formulated styrene modified polyester resin.

Sheet-dye process: (slasher-dyeing process) A conventional continuous dyeing process for the dyeing of cotton warp yarns in open-width form, chiefly with indigo.

Sheet, fitted: See **Fitted sheet**.

Sheet, flat: See **Flat sheet**.

Sheet, in textiles: A large rectangular usually plain woven fabricated product which is used over a mattress on a bed. The product may be carded or combed yarn in a wide range of constructions.

Sheeting: Since the introduction of fitted sheets and duvets, and particularly since coloured and printed sheets became popular, sheeting has been made available to us as piece goods. It can be plain or printed and in all colours. Most of it is 50% Polyester and 50% cotton for easycare. Used for sheets, pillow covers, duvet covers, valances, curtains etc.

Shelf Life: The period of time some product can be stored “on the shelf” before it degrades to some point of reduced effectiveness. Some chemicals, including dyes, have limited shelf life. They degrade over time, eventually becoming completely useless for their intended purpose. Useful shelf life may range from hours to hundreds of years. For example, an enzyme used for desizing might be specified as losing about 10% of its strength after storage at 20°C for six months – it is still very useful, just slightly weaker. Shelf life is generally maximized by storage at low temperature (sometimes even freezing, but this can damage some products). Chemicals should also usually be protected from long exposure to bright light, and dry chemicals should be protected from humidity by storage in tightly closed moisture-proof containers.

Shell: A fabric from which the garment is made.

Shenti: Loin cloth or hipskirt, highly pleated and decorated.

Sheperd’s plaid: See **Sheperd’s checks**. Twilled woollen fabric, made with black and white checks, formed by long and cross bars in black over white ground.

Shetland: (1) Originally, the term “Shetland” was a mark of origin for a yarn spun by hand exclusively from the wool of sheep bred and reared in the Shetland Islands. The wool from the Shetland sheep is particularly fine and imparts a soft handle to the textiles produced from it. (2) Currently, the term “Shetland” is applied loosely to all medium to coarse carded yarn fabrics produced from fairly coarse wool qualities (roughly equivalent to C quality), usually with a twill weave construction and a light to medium melton finish.

Shetland Lace: Bobbin lace made of black or white Shetland wool yarn.

Shetland Point: Needle-point lace made of Shetland wool in Italy.

Shetland Shawl: Fine knitted or crocheted light shawl made of Shetland wool.

Shetland Veils or Falls: Shawls, loosely knitted of wool, often containing camel, goat or alpaca hair, and made with scalloped edge.

Shetland Wool: (1) Very fine and lustrous wool, yielded by the Shetland sheep. The real Sh. wool is an undergrowth, found under the longer hairy wool and is not shorn but roo'd (or pulled by hand) in the spring. It comes in white, gray or brown, and is one of the costliest wools known. The wool is scoured and spun by hand, then treated with the fumes of sulphur and made up into hosiery, underwear, crochet work and very fine shawls; (2) English two-strand fine knitting yarn.

Shibori: A Japanese tie-dyeing technique In shibori, fabric, usually silk, is folded or twisted or tied or wrapped around a bamboo pole (often substituted with PVC or ABS pipe), and dye is directly applied. This simple statement does not do justice to the craft and its beautiful results.

Shier, in woven fabric: Fine warpwise cracks randomly distributed across the fabric width.

Shifu: Thread made from paper is an old Japanese tradition and has been used historically in clothing.

Shikhara: A bandhani design. See **Bandhani**.

Shikifugi: Cotton bed sheeting in Japan.

Shima Momen: Striped cotton fabrics in Japan.

Shiner: A relatively short streak caused by a lustrous section of a filament yarn. The principal cause is excessive tension applied to a yarn during processing.

Shipment: Goods or commodities which are transported together as a unit. A quantity of product for which for which a bill of lading has been signed by the carrier.

Shiraz: Persian, all-wool rugs made in all sizes. The medium long pile is tied in Ghiordes knot. The end selvage is often checked. The design consists of palm patterns, stripes with blue and red as prominent colours. Also called Mecca ruge.

Shiraz carpets: Contrary to expectations, Shiraz carpets are not produced in Shiraz itself but in the whole Fars area of which Shiraz is the capital. The various carpets known by this name are, in fact, woven by different nomadic tribes who have lived for centuries on the Fars tableland. The bazaar in the

town of Shiraz is the trading centre for these carpets. Some tribes use the Persian knot whilst others use the Turkish. In both cases, the number of knots per unit area varies considerably, e.g. 100 000–250 000 knots/m².

Shiraz Gum: See **Asiatic gums**.

Shirer: See **Crack**.

Shirey Yarn: Flax yarn with a flaw caused by improper setting of the reach.

Shirley Institute: A well-known British textile research institute based in Didsbury, Manchester, formerly the headquarters of the British Cotton Industry Research Association (BCIRA). The Shirley Institute was amalgamated with the Wool Industry Research Association (WIRA) in 1988 to form the British Textile Technology Group (BTTG).

Shirley stiffness test: This test measures the bending stiffness of a fabric by allowing a narrow strip of the fabric to bend to a fixed angle under its own weight. The length of the fabric required to bend to this angle is measured and is known as the bending length.

Shiro-momen: General trade term in Japan for unbleached (similar to nankeen), and bleached plain woven cotton goods. The harrow, plain woven cotton fabrics, made on hand looms and half bleached or often dyed blue are also called by this name; used for socks and clothes for the people.

Shirred Fabrics: A range of fabrics with one edge elasticated to a depth of 6–10 cm. (2½ – 4 in.) and sold as ready to sew skirt and sundress fabrics. Often of cotton fabric, but may be of others such as polyester, usually pointed. Used for casual clothes and children's tops and dresses.

Shirring, in garment making: Fabric is drawn up to create fullness using a fine elasticized thread down as shirring elastic. It can be used in a series of lines, depending on the effect required.

Shirting: Any fabric of any fibre that is closely woven and implies absorbent, hard wearing qualities. The most common are made from, cotton, silk, polyester and cotton.

Shirvan Rugs: All-wool rugs made in Caucasia. The warp and weft being of white, gray or dyed wool; the loose pile is tied in Ghiordes knot. The patterns are geometrical in blue, White, yellow and red colours. The ends are finished in long, knotted fringe.

Shirvan carpets: Provenance: the village of Shirvan is situated near the south-west shore of the Caspian Sea and the district of the same name in the southern part of Azerbaijan. Technical details: The warp and weft is in wool in antique specimens, in wool or cotton in those woven between 1850 and 1920,

and completely in cotton in modern examples. The pile is always in closely cropped wool. The Turkish knot is used to give a knot density of 150,000–250,000 knots/m². Modern examples usually have a higher knot density than the older or antique ones.

Shives: (1) All vegetable matter, except burrs, found entangled in the wool. (2) Short pieces of woody waste in flax which are almost entirely removed during the breaking and scutching operations involved in flax processing.

SHMP: Sodium hexametaphosphate.

Shock catalyst: A strongly acidic catalyst used in the application of resin finishes by the Shock-cure process, e.g. certain organic acids such as citric acid, mixtures of metal salts of strong acids with complex forming hydroxycarboxylic acids.

Shock cooling: Rapid cooling, e.g. of dyed goods, or a more or less exhausted dyebath, by partially running the dyeing machine and adding cold water. Purpose: to control the temperature, e.g. when making further additions of dye for shading. Shock cooling is also carried out after the heat-setting of synthetic fibres by impingement with cold air in order to stabilize the heat-setting effect.

Shock Drying: The shock-like drying of textile fabrics in jet drying (Jet driers).

Shock Dyeing: Rapid transfer of dye liquors into a dyeing machine.

Shock-Cure Process: A variant of the Dry crosslinking process; in this case, crosslinking is achieved by shock curing within a few seconds (20–60 s) either at high temperatures (170–190°C) with conventional resin finishing catalysts, e.g. magnesium chloride or, alternatively, at 140–160°C with so-called Shock catalyst. Both the drying and curing stages are usually combined in a single pass through a finishing stenter.

Shoddy: (1) The fibrous material made in the wollen trade by pulling down now or old knitted or loosely woven fabric in rag form.

(2) Droppings from woollen cards consisting of very short fibres that may be heavily changed with oil or dust.

Shoddy: Fibres made from ground-up rags and mixed with other fibres to reduce the cost.

Shoddy Shaken: A machine used for shaking shoddy reclaimed from under carding machines. It consists of a revolving cage, covered with perforated polished steel: having a revolving swift with long steel bars attached. The swift and cage revolve in opposite direction

Shoddy Wool: See **Shoddy (2)**.

Shoe Cloth: Very strong and durable worsted, woven with corkscrew weave, weighing between 12 and 18 oz. per yard. The warp ends vary from 80 to 150 per inch with picks ranging from 80 to 140 to an inch. The warp is usually double thread and the filling single worsted, sometimes also cotton. The cloth is usually made as single fabric; used for shoe tops.

Shoe Fold: A fabric folded from both ends into twelve or sixteen folds to the piece, the length of the fold depending upon the length of the piece.

Shoe Fold: See **Fold, shoe**. A manner of folding fabric. The piece is folded from both ends into twelve or sixteen folds. The length of the fold depends upon the length of the piece.

Shog, shogging: See **Warp knitted fabric**.

Shogged Stitch: Rachel stitch. In knit fabrics; used to form the edges of the garments.

Shooda: Commercial name for a lightweight twilled woollen dress fabric.

Shoot: Another name for weft.

Shooting Coat: A sack coat of corduroy, duck, etc., with capacious pockets, used by sportsmen. An old term.

Shooting Jacket: See **shooting coat**.

Shore Hardness: A hardness scale which is in common use internationally for vulcanized materials such as rubber as well as plastic rollers. Measurements are made with a hand-held tester in which the resistance of the material under test to the pressure exerted by a needle is read directly off a scale. It is, however, not altogether accurate. Measurements range between 40–100 Shore which can, however, represent different degrees of roller hardness for various makes of rubber.

Shorn pile: Pile that is removed when a specimen is sheered.

Short Bast Fibres: Cottonized bast fibres; Cottonized flax.

Short-Cure-Process: A 2-stage permanent-press finish. Stage 1: mild curing of finished fabric for a short duration at low temperature. Stage 2: final curing under severe curing conditions after the fabric has been made up into garments.

Short Liquor: In the sense of liquor with a low amount of liquid, e.g. 1 : 5. Opposite: Long liquor.

Short Liquor Jet: Waste water quantities and energy use are substantially decreased in dyeing in an exhaustion process using a short liquor-to-goods-ratio (MLR).

Winch beck	MLR 1: 30
Short liquor jet	MLR 1: 6
Airflow	MLR 1: 3

Short liquor ratio dyeing: Dyeing in accordance with the exhaustion processes in the short liquor-to-goods ratio, in general 1 : 10 and below, brings the benefit of less water and energy consumption.

Short Loop Drier: (festoon drier). Universal drying machine for delicate viscose fabric, for tubular jersey fabrics and for the gentle pre-drying of resin impregnated fabrics to avoid pre-curing and migration of the epoxy resin. Tension-free transport of the fabrics in the form of short loops passing in continuous travel over vigorously vibrating rollers, producing constantly changing points of contact.

Short period dyeing technique: Process for increasing productivity with the aim of reducing dyeing time to a minimum without jeopardising the leveling of the dyed goods.

Short period heat setting: (shock setting), takes place on special stenters, on which synthetic fibres are thermofixed in seconds at very high temperature.

Short-Cure Method: A 2-stage permanent-press finish. Stage 1: mild curing of finished fabric for a short duration at low temperature. Stage 2: final curing under severe curing conditions after the fabric has been made up into garments.

Short-Cut Staple: Staple fibre less than 0.75-inch long. Typically used in wet-laid nonwoven processes to make fabrics, or as reinforcement in plastics, concrete, asphalt, and other materials.

Short-Liquor Dyeing: Dyeing in low MLR.

Shot: (1) Name in England for pick; (2) Another name for changeable or mottled effect.

Shot: The term used to describe the effect created by using one colour of the warp and a totally different colour in the weft. Any fibre may be used, but the most effective are the shiny ones, such as acetate, triacetate, polyester and silk.

Shot, in pile floor covering: The number of filling yarns per row of tufts.

Shot effect: A changeable colour effect on a lustrous or shiny fabric in which the warp yarns and weft yarns are of contrasting colours. The fabric normally has a plain weave or a 2/2 twill weave when this effect is required.

Shot, in pile floor covering: The number of filling yarn per rows of tufts.

Shot Effect: The variable colour seen when certain fabrics are viewed at different angles. The effect is obtained by having warp threads of one colour and weft threads are of a contrasting colour.

Shot Taffetta: One of the most luxurious type of Taffetta, as it is made from two colours and can be seen to change the colour as the wearer moves.

Shooting Yarn: See **Yarn, shooting.**

Shoulder Circumference, in body measurements: With arms down at sides, the maximum distance around the shoulders at the top of the arm.

Shoulder Joint, in anatomy: The junction of collarbone and the shoulder blade.

Shoulder Length, in body measurements: The distance from the side neck base to the arms eye line at shoulder joint.

Shoulder Padding: Shaped inserts used as Interlinings in men's and women's jackets and coats to confer a desired shape. Shoulder padding usually consists of wool or cotton wadding (often lined with muslin) and/or an expanded foam material resistant to dry cleaning.

Shoulder point, in sleeves: The highest point on the sleeve cap; generally located at the center of the sleeve.

Shoulder Slope, in body measurements: The angle formed when the slant of the shoulder line deviates from the horizontal line that originates at the side neck base.

Shoulder, in Zippers: The bearing surface of an interlocking element by which the chain is contained inside the flanges of the slider.

Shower curtain: A hanging fabric used to prevent water spillage from the shower area.

Shower Proof Cotton And Latex: A base fabric of cotton, or polyester/cotton, resembling cheese cloth in appearance and sprayed on one side with Latex to make it shower proof. The layer of Latex is quite thin so the right side of the fabric is wrinkled like the Cheese cloth. It is soft fairly floppy cloth. Used for raincoats, jackets hats.

Showerproof: Treatment of a textile fabric so as to delay the absorption and penetration of water. In the case of a fabric, a degree of permeability to air is retained.

Showerproofing: A light proofing given to fabric by treating them with metallic salts, insoluble soaps or silicone based preparations. The thermal and ventilating properties and the general appearance are not much affected by these treatments. The term has no precise meaning and heavy rains should be expected to penetrate coats made from such material.

Shredding: The separation of compressed fibres in pulp sheets prior to acetylation in acetate manufacture.

Shrinkage: A decrease in one or more dimensions of an object or material.

Shrinkage: The reduction in a dimension of a fibre, yarn or fabric. Shrinkage may be induced by various treatments, e.g. wetting, steaming, alkali treatment, laundering, dry heat.

Shrinkage A negative change in the dimensions of textile products which involves a reduction in area (length and/or width) of a fibre, yarn, fabric or other textile due to the influence of various agencies, e.g. wetting, laundering, dry cleaning, etc.

Shrinkage in boiling water: Change in the length or width of a specimen immersed in boiling water, distilled or demineralised for a specific time.

Shrinkage of yarn in skein form: The change in loop length of a skein expressed as a percentage of the length prior to exposure to the shrinkage medium for e.g. boiling water.

Shrinkage in DP finished fabrics: Much of a fabric's residual shrinkage is the result of tensions applied to the fabric during wet processing. Some woven fabrics will shrink both in width and length during preparation and dyeing. These must be pulled out to maintain width and yardage yields. These stresses add to residual shrinkage. Knit goods are inherently wrinkle resistant; however, some are pulled out to a width wider than the fabric's knitted gauge and this too adds to residual shrinkage. Much of the stress induced shrinkage can be eliminated by mechanically compacting the fabric. Compacting will result in reduced yardage yields. Crosslinking also reduces fabric shrinkage. For this reason, chemical stabilization of cellulosic fabric has real economic value. Without resin finishes, the fabrics described here will have excessively high residual shrinkage. Fortunately, a good resin finish will stabilize the fabric and reduce the residual shrinkage to less than 2%. The degree of stabilization required by chemical finishes will depend on the fabric's previous history. In some cases, much more finish is applied than one would reasonably consider simply to keep residual shrinkage within the required tolerances. In these cases, reduced shrinkage is the real reason for DP finish rather than wrinkle resistance or non-iron features.

Shrinkage Force: The force generated by thermoplastic materials when they are subjected to elevated temperatures.

Shrinking Machines: Machines for the shrink-resistant finishing of textiles by mechanical compression in a moist hot state (Compressive shrinkage) or a tension-free treatment in a steam atmosphere. The objective is to achieve residual shrinkage values up to 1% max. in subsequent use.

Shrinkproof finishing: Grammatically speaking, this is a term that should really be restricted only to finishes capable of producing a fabric with a

residual shrinkage of zero (an absolutely shrinkproof fabric is not possible in practical finishing) but which is commonly used (erroneously) for finishes which reduce the residual shrinkage of textile fabrics to a level consistent with their fitness for purpose. The correct term for these finishes is Non-shrink finish.

Shrink-Resistant Finish: Non-shrink finish.

Shropshire: A breed of sheep in England and Australia yielding a long, fine, strong and lustrous wool.

Shroud: The last garment we wear.

Shusu: Japanese silk satin.

Shuttle: A boat-shaped device, usually made of wood with a metal tip that carries filling yarns through the shed in the weaving process. It is the most common weft-insertion device. The shuttle holds a quill, or pirn, on which the filling yarn is wound. It is equipped with an eyelet at one end to control rate. The filling yarn is furnished during the weaving operation.

Shuttle chafe mark: A fabric defect that is usually seen as groups of short, fine lines across the fabric, often running for some distance in the piece and usually in the same area. Although these marks run in the direction of the filling, they are actually caused by the shuttle rubbing across and damaging the warp ends, producing a dull, chalky appearance.

Shuttle looms: (shuttle weaving machines). In a shuttle loom, the weft is inserted by means of a Shuttle which is propelled over a race plate through the shed of separated warp yarns. The shuttle is propelled from side to side by a wooden shaft called a "picking stick" so that the weft yarn is inserted alternately from left to right and vice versa thus producing a closed selvedge (in contrast to all of the more modern Weft insertion systems introduced in the meantime).

Shuttle, boat: Boat shuttles (which look a bit like boats) are equipped with a central hinged rod on which a bobbin (a slender spool) wound with the weft thread is placed. The bobbin rotates as the shuttle is thrown, and the weft is pulled snug at the selvedge by the drag of the unwinding thread against the rotating bobbin.

Shuttle, End-feed: An end-feed shuttle has a shaft secured at one end that supports a pirn (like a bobbin but with narrower end). The weft is pulled off the narrow end of the on rotating pirn and tensioned with an adjustable tensioning device at the nose of the shuttle.

Shuttle, Stick: They are flat pieces of wood that are usually notched at each end so that the weft can be wrapped from end to end around the shuttle. The

shuttle must be turned over a time or two as it is brought out of the shed to free weft yarn for the next pick. The turn of the thread at the selvedge must be adjusted manually.

Shuttleless Loom: A loom in which some device other than a shuttle is used for weft insertion.

Shyer: See **Crack**.

SI: Le Système International d'Unités" or International System of Units; a modern metric system in which meters, kilograms, seconds, amperes, candelas and moles are the base units internationally adopted metric system of units. It has seven BASE UNITS and two dimensionless units, formerly called supplementary units. DERIVED UNITS are formed by multiplication and/or division of base units. Standard prefixes are used for decimal multiples and submultiples of SI units, along with standard symbols for both units and prefixes.

SI: Israel Standard.

SI: Sisal.

Si: (1) Sisal, 1988; this abbreviation was changed. (2) Symbol for the non-metallic element silicon (atomic number 14).

Siara: Variety of raw cotton from South America.

Sibirienne: Plain woven or twilled, thick woollen fabric with a long nap, finished with a high gloss.

SIBR: Suspended immobilised biomass reactors, i.e. a *moving bed biological reactor*.

Sibucara: Silky seed hair, grown on a species of the Bombax tree in Venezuela; used for stuffing.

SIC: Israeli Standards Organization.

Sicilan: A plain-woven mohair fabric; see **Brilliantine; Mohair**.

Sicilian: A lustrous, lightweight fabric, made of fine, hard spun cotton warp and mohair filling of lower count in plain weave.

Sicilienne: This was first made in Sicily as a coarse-weave lining fabric of mohair and cotton. It is now a plain woven fabric with heavy weft ribs, made from silk, cotton and oil mixtures resembling poplin appearance. It is very occasionally used as a dress fabric.

Sida: White, strong and lustrous bast fibre yielded by the sida plants in India, South America and Australia; used for cordage.

Siddo Rags: Rags consisting of interlining from garments the best type of siddo rags are from fabrics made from yarns of hair or blends of hair with wool made on the worsted system.

Sidebands: Fabrics in America, usually printed with a band effect near to one of the selvages. They are used for trimming purposes.

Side-By-Side Fibres: (S/S types) Bicomponent fibres.

Side-to-side shading: Tailing.

Siebenburgen Rugs: Small oriental Knotted carpets, which arrived in Siebenbürgen during the Turkish occupation of South-Eastern Europe and were used to decorate the churches in the manner of the independent principality at that time.

Siemens: Derived SI unit of Electrical conductance, e.g. for electrometric measurements. 1 S is equal to the electrical conductance of a conductor of electrical resistance 1.

Sieuhwakin: Chinese shawls made of embroidered white crepe.

Signaton: Rich silk dress goods of the Middle Ages, originated from the Orient.

Sign Cloth: Heavily starched, coarse bleached cotton muslin; used for signs.

Sight glass: Built into pipelines, condensate returns, etc. for checking the flow, purity, absence of bubbles.

Sighting dyes: Non-substantive dyes for the particular substrate, which can be added to colorless printing pastes to reveal repeat inaccuracies on blades and rollers and later washed off again (e.g. for white discharges, half-tone reserves, leuco vat ester dyes, stabilized azo dyes, phthalocyanine dyes). Frequently also colourless substances (e.g. fluorescent brightening agents) which fluoresce in UV light.

Silence Cloth: Heavy and thick bleached cotton flannel strongly raised on both sides and napped cotton fabric; used underlay for table cloth ironing boards and beds.

Silesia: A light, close-woven, fine twilled cotton fabric, dye in dark shades and calendared for a glossy finish, used for dress linings, and in tailoring for the bags of pockets etc. Made in a limited range of dark colours.

Silhouette: French, plain woven cloth of cotton warp and a different coloured linen filling, giving a scintillating effect.

Silicate boiler scale: (SiO_2), most dreaded modification of Boiler scale, caused by silicate in boiler feed water (even 5–10 mg/l SiO_2 is a risk to boilers

operating at high pressure). Has a particularly low thermal conductivity. 0.2 mm layer thickness causes local overheating, buckling of the tubes, etc.

Silicates: Salts of the meta, ortho and polysilicic acids. Not soluble, non-decomposed in any solvent. The aqueous solution has a limited service life (tendency to gradual flocculation or drying up). Even a small addition of acid causes gelatinous separation (Sodium silicate; Water glass).

Silicone-based dyes: These dyes serve to permanently dye glass fibres in dark shades, as well as to modify the properties of normal silicone oils and resins.

Silicone-based textile auxiliaries: Silicones represent important auxiliaries in the textile industry for processing and finishing. They have many advantages due to their universal application possibilities, problem-free handling, free choice of type of application, gentle cross-linking, great efficiency and slight environmental pollution.

Silicon Carbide: (carborundum), SiC, variously coloured (reddish, greenish blue, black) crystals, very chemical and heat resistant, diamond-like hardness, density 3.2. Is obtained from coal and quartz at over 2000°C. Use: as grinding and polishing material; for fire-resistant bricks and electrical resistance bodies.

Silicone cross-linking: For the silicone crosslinking of reactive-group olydimethylsiloxane at least trifunctional cross-linkers are required so that an elastic network structure is achieved, e.g. methyl hydrogen siloxanes, tri- or tetra- alcoxysilanes and triaminoalkylsilanes. Silicone cross-linking usually takes place in the presence of special catalysts and may drain off as condensation (OH terminal group), addition (vinyl terminal group) and as peroxide cross-linking (methyl terminal group).

Silicone catalysts: Hydrogen methyl polysiloxanes (Silicones) require special catalysts for cross-linking, the choice of which creates the possibility of influencing the overall effects of the fabric.

Silicone elastomers: High-molecular Polydimethylsiloxane with terminal hydroxyl groups, which cross-link with hydrogen methylpolysiloxanes in the presence of catalysts, e.g. tin alacyl compounds or silicic acid esters. Used in solvents or aqueous emulsions (solvent technique enables better effects) as Silicones in finishing, e.g. for elastic finishing of knitwear made of synthetic fibres, antifelting finish and the like.

Silicon Finishes for textiles: Give the textiles, if desired, hydrophobic properties (silicone additive of 1–1.2% of the dry weight of the fabric), protection against wet dirt, a soft handle and improvement to the sewability and abrasion resistance.

Silicone finishes, stripping: May be required with defective silicone finishes. Is difficult, however, particularly if the fault is not detected until after hardening. By means of an acid treatment with 60 g/l hydrofluoric acid (alternatively oxyl acid and suitable polyphosphates and acid-resistant wash-active substance) in 60 min at 80–90°C, if necessary with a subsequent chemical cleaning.

Silicone rubber: Synonym for Silicone elastomers. Poor resistance to abrasion. Resistance to acids is excellent to moderate, to solvents poor (aliphatic/aromatic hydrocarbons), to oxidation, ozone, sunlight ageing, excellent, to flammability moderate to good.

Silicone Softeners: Silicones provide textile substrates with a combination of soft handle, smoothness, gloss, fullness, elasticity and sewability with excellent permanence at the same time. The softening effect of the silicone oils is based on their slide performance both on the fibre surface and in the fibre itself. Amino-functional groups linked to polydimethylsiloxanes enable an improved orientation and substantivity of the silicone on the substrate. This leads to an optimally soft handle and is often described by the term “supersoft”.

Silicones: Silicones are Polysiloxane Polymers and fall under the class of materials known as organometallics. The element silicon is considered a metal and is found in abundance in nature as silica, SiO_2 . Silicon resembles carbon in that it is tetravalent and forms covalent bond with other elements. Simple tetravalent compounds are called silanes. Silicon forms a stable covalent bond with carbon leading to a class of materials known as organosilanes. For example methyl chloride reacts with silicon to form a mixture of silanes as shown in the box below. The mixture includes silanes containing methyl, chloro and hydrogen groups in varying proportions. Chlorosilanes rapidly react with water to form silanols which further condense to form siloxane linkages. Dimethyldichlorosilane will form linear polysiloxanes which are water clear oils with excellent lubricating properties. The viscosity of the oil will vary with the molecular weight. Utilizing appropriate monomers and reactive groups, polysiloxanes, better known as silicones, are also found as three dimensional resins and high molecular weight elastomers.

Silk: A fine, strong, continuous filament produced by the larva of certain insects, especially the silkworm, when constructing its cocoons. The silkworm secretes the silk as a viscous fluid from two large glands in the lateral part of the body. The fluid is extruded through a common spinneret to form a double filament cemented together. This double silk filament, which is composed of the protein fibroin, ranges in size from 1.75 to 4.0 denier, depending upon the species of worm and the country of origin. The filament of the cocoon is

softened and loosened by immersion in warm water and is then reeled off. Although raw silk contains 20 to 30% of sericin, or silk glue, and is harsh and stiff, silk is soft and white when all of the glue has been removed by steeping and boiling in soap baths. Ecu is harsher, as it has only about 5% of the sericin removed. Silk is noted for its strength, resiliency, and elasticity. The major sources of commercial silk are Japan and China.

Silk Bolting Cloth: See **Screen mesh, Screen gauze.**

Silk damage: Testing for damage to natural silk occurs by determining the viscosity of a solution of natural silk in concentrated aqueous lithium bromide solution.

Silk burlap: Silk fabric of linen weight, but feels light and drapes well. Various widths Used for suits and dresses.

Silk Camlet: Silk cloth of two-coloured warp, the filling being of a third colour.

Silk Cotton: A widely used term, applied to the fine and lustrous fibres yielded by the seed pods of a great number of trees and plants.

Silk dusting: Occurs due to the splitting up of silk under the effect of alkali or too great a mechanical stress in the working liquors and gives the fabric surface a whitish appearance, as if sprinkled with flour.

Silk dyeing: The most important dye classes are acid, metal complex (predominantly 1 : 2), direct and reactive dyes. Cationic, after chrome, vat (indigo) and vat leuco ester dyes are only used in special cases. In the high-fashion sector, classic brilliant shades in the red, blue and green range cannot as yet be replaced by more genuine products of equal value.

Silk grass: (Honduras silk grass) Longest type of bast fibres belonging to the Bromelia fibres (Central and South America). Cream-coloured, silky bright, fine and soft (surpassing the Cantala and Mauritius fibre).

Silk Grassy: General term applied to many lustrous fibres of the pineapple or other plants, especially the white, strong and silky fibre yielded by the *Furcroea cubensis*, in tropical America.

Silk Nankeen: English nankeen having silk satin stripes over a cotton foundation.

Silk Wadding: Waste silk resulting from spinning bourette silk.

Silkeen: A finely ribbed English cotton fabric, printed with coloured pattern over a coloured foundation and highly glazed.

Silk jacquard: Medium weight, luxurious silk patterned fabrics. Depending on the design, the Jacquard weave may give a moire' effect. The fabric drapes

well and as silk dyes so well will often be found in jewel-rich colours. Used for evening and bridal wear, luxury suits, blouses and kimonos.

Silk jersey: A fine lightweight knitted fabric, often printed. It drapes beautifully, wears well and always looks superb. Used for special outfits, dresses, blouses and long dresses.

Silk Mousseline: It is firmer than chiffon, and is cool and comfortable, but it does not wear well as laundering spoils it and dry-cleaning is always not satisfactory. Used for evening dresses. See also **Mousseline**.

Silk Noil: An attractive silk fabric of dress or suit weight, its feature is that it has small pieces of cocoon woven in it and these appear as dark cream flecks.

Silk ribbon finish: A finish done on yarn dyed pure silk fabric (Taffeta, Liberty structures) to get a full, solid hand feel without stiffness or hardness using resins and ether soluble gums in benzole. This type of finish explained is of historic importance only. Nowadays this finish done using suitable synthetic resins and additives.

Silk Satin: A very soft lustrous fabric for luxury lingerie. It is expensive and drapes beautifully but creases. Used for all items of lingerie, especially in conjunction with lace.

Silk scroop: A special finish applied on the fabric earlier days for a scroopy handle, craquant, crackly finish, crunchy feel, silk finish, silky handle by the treatment of textiles with soap or fat emulsion and organic acids (folic, lactic, acetic, tartaric, citric acid). The silk scroop is not usually stable in storage, leaves an unfavourable flabby handle and a slightly rancid odour due to the eliminated fatty acids due to humidity in the air. Nowadays the finish is imitated by other synthetic chemicals.

Silk Shantung: A medium weight silk fabric woven with irregular yarns. The fabric has a dull appearance and rough texture and is popular for blouses shirts and dresses. It is also referred to as Nankeen or Rajah and also sometimes carries the name of the province where the yarn is originated.

Silk Twill: A soft twill weave silk fabric without much body, usually printed. Printed squares often made up as scarves. Used for blouses decorative features, possibly pyjamas.

Silk weighting: The weighting process is carried out to increase the silk weight, providing fuller hand, more lustre and bulk, and making the fibre suitable for the manufacturing of fabrics to be used, for example, for ties. The weight increase is expressed as percentage weighting above or below the parity. Parity weighting means that the fibre regains the original weight it had before the degumming process:

Percentage weighting = (weight after weighting - raw weight) x 100/ raw weight.

There are many types of weighting; till some years ago, a few mills still carried out mineral weighting, but now this process has been abandoned definitively. Today, the most frequently applied type of weighting is synthetic weighting (or chemical linking).

Silk, Boiled Off: Silk with the gum (sericin) removed.

Silk, Raw: see **Raw silk**. Silk as it has been reeled from the cocoon.

Silk, spun: see **Spun silk**. Silk yarn consisting of short filaments obtained from silk wastes spun in a similar manner to worsted yarn.

Silk, Thrown: see **Thrown silk**. Raw silk that has been twisted or doubled and twisted.

Silkalene: A very light, printed, plain woven, glossy cotton fabric, made in the gray and calendered; used for lining, curtains, etc.

Silkworm Gut: Used for fishing lines; the silk worms are immersed in strong vinegar for a couple of hours and then pulled apart, each worm yielding two thick strings of great strength.

Silk union: A term used for fabrics that contain natural silk or filament yarns similar to silk in one thread system.

Silk waste: See **Bourette; Schappe (silk)**.

Siloxanes: Compounds containing Si–O–Si groups with organic groups bound to the silicon atoms. The silicones are polymers of siloxanes. Oxygen compounds of Silicon. Polysiloxanes: See **Silicones**.

Silver Cloth: French fabric, composed of 4-5 of wool and one-fifth of asclepias cotton

Silver number, silver index: A number to denote the bleach damage on cellulose fibres. The number indicates how much silver is reduced and separated from 100 parts test material numerical expression of bleach damage on cellulose fibres.

Silver test, in textile: Test solution is made as follows: Solution A: 1 g silver nitrate and 10 ml water. Solution B: 4 g sodium thiosulphate and 100 ml water. Mix solutions A and B, and add sufficient thiosulphate until the precipitate is dissolved. Then add solution C (4 g ammoniac and 100 ml water). Bring everything to the boil, filter and preserve the light-sensitive solution in brown bottles. Application: to test for hydrocellulose, especially with subsequent treatment with dilute ammoniac. Yellow-brown colouring according to the degree of damage. Also to test for wool damaged by sunlight (black coloring).

Silver prints: Graphite prints. Carried out with appropriate Metal powders.

SIM: Malaysian standards organization.

Simili Mercerising: A calendering process for increasing the lustre. The effect is similar to that obtained by mercerizing but not permanent.

Simple Machine Stitch Pattern, in sewing: A repeating segment of machine stitches, with each repeat consisting one or more stitches long.

Simplex Fabrics: Velour-type surface processing of knitwear made of cotton or synthetic fibres such as polyester, polyamide, acetate and triacetate. Originally limited primarily to glove qualities, for clothing fabrics including sport and leisure articles.

Simplex machine: One of the earliest machine designed to dye loose cotton. It consists of a rectangular vat fixed on supports. Steam pipes are fixed in the bottom of the trough. Above the steam pipes there is a free perforated plate on which two or more hooks are attached. Ropes are attached to these hooks which is taken above the trough on an eccentric pulley. Cotton is loaded above the perforated plate and closed above it with another perforated plate. The liquor is heated and the package of loose cotton is worked up and down by means of the eccentric pulley when a more or less even dyeing takes place.

Simulated grass matting: Rot resistant, coarse artificial grass matting made from coloured synthetic fibres, usually polypropylene.

Simulated Spun Yarns: Filament yarns that have been modified to have aesthetics similar to those of spun yarns. Simulated spun yarn have looped or hairy surfaces.

Simulation tests: Degradation test procedure to assess the biological level of waste water treatment plants. The degradation process is simulated in laboratory models under practical operating conditions, as in the aeration tank of a waste water treatment plant.

Sinamay: ‘Light, plain woven fabric, made by the natives of the Philippines of abaca fibres. It usually comes in contrasting coloured stripes; used for garments by the natives.

Sinclaii: A Highland tartan, composed as follows: *Green stripe; group (as wide as green stripe) composed of a black stripe, a fine white line and a blue stripe, the latter being wider than the black; “red stripe, being somewhat wider than all the stripes mentioned above; repeat, in reversed order, stripes mentioned between two.*

Singeing: Scorching, gassing of fibre ends protruding from surfaces on yarns, fabrics, etc. if a fluffy fabric is not required. An industrial defibrillation process

where rapidly-moving fabric passes over a flame or a very hot plate in order to burn away fibres poking up from the surface. Also see gassing. Singeing is predominantly carried out on textile fabrics manufactured from yarns in the form of knit-goods or wovens. The aim is to achieve a smooth and fibre-free surface, which is essential both for subsequent processing in textile finishing and for desired serviceability properties.

Singeing Machine: Especially used for woven and knitgoods with low-tension controlled throughput involving several singeing positions: tangential, counter roll and counter-fabric. Especially used for the technical pretreatment of knit-goods in tubular form prior to mercerization

Single-bath chrome dyeing process: Chromate dyeing process; Chroming of dyes.

Single-bath chrome mordant: Metal mordants, for mordant and chrome dyes.

Single-bath exhaustion process: Dyeing process in which several components are applied to the fibre in a dye bath, e.g. dispersion dyes and cotton, wool or cationic dyes.

Single-bath process: Treatment, especially for dyeing blended fibres, in a bath, i.e. with dyes for each component. Contrasting process Two-bath process, i.e. treatment in two consecutive baths. Variants: Single bath single-stage process corresponds to singlebath process. Single-bath two-stage process, whereby, at the end of the first treatment stage, the second stage is carried out in the same bath.

Single Breasted: A style of coat or other garment with minimum overlap and a centre front fastening.

Single broadcloth: See **Broad cloth**.

Single Canvas: A popular plain weave cotton, or cotton/polyester, embroidery canvas of fine construction, with easily distinguished holes between the warp and weft threads.

Single Cloth: Is woven with one set of warp and one set of filling, irrespective of the weave.

Single Coarse Raw Silk: Simple, coarse raw silk thread (8–10 cocoon threads) made from inferior cocoons, e.g. as inlay threads for spun metallic yarn.

Single Damask: Both the ground and the pattern, or only the ground is woven in five-leaf satin.

Single end sizing Process involving guiding threads through nozzles which separate several chambers from each other. Residual drying in heated pipes

(< 12 m long), subsequent batching on cross wound yarn packages. Owing to the fast speeds, not suitable for sizing warp ends in industrial standards. Applied to special yarns (e.g. asbestos threads, novelty yarns, sighting thread). Basic disadvantage: nozzle change for each size range.

Single Face Fabric: (plain jersey fabrics) Knitted fabrics with only right-side loops on one side of the fabric and only reverse-side loops on the other side of the fabric.

Single filaments: Monofilament chemical fibres.

Single Jersey: This is often wool, but sometimes may contain acrylic fibre. It is a knitted fabric that is thin and curls at the edges. The right side only has the stocking stitch appearance, the wrong side is the reverse and like hand knitting in effect. Single jersey may be plain or mixed colours, in random stripes. It is soft and drapery. Used for soft gathered dresses and suits.

Single jersey jacquard, weft knitted: A patterned single jersey weft knitted fabric usually made from two or more yarns of differing colour or texture to give a construction that consists essentially of knitted and float loops but may incorporate tuck loops. The surface pattern is derived from the chosen arrangement of the yarns knitted and float loops. The inclusion of tuck loops into the construction is to eliminate long lengths of floating thread from the back of the fabric.

Single jersey tuck jacquard, weft knitted: A patterned single jersey weft knitted fabric usually made from two or more yarns differing in colour or texture to give a construction that consists of knitted and tuck loops. The surface pattern is derived from the chosen arrangement of yarns knitted and tuck loops.

Single lapped seam: A lapped seam used to eliminate bulk when piecing interfacing and interlining edges together. The seam does not produce a finished appearance, and should not be used to seam the garment itself.

Single Level Pile, in floor covering: Having all pile tufts at the same level.

Single Phase Printing Process: The printing paste contains, besides dyestuffs, the chemicals required for the application, e.g. reducing agents with vat dyes or alkalis with reactive dyes.

Single Plush: A plain knitted fabric, made with one face yarn and having the backing yarn almost entirely on the back of the cloth. It is then napped; used for underwear.

Single poplin: See **Poplin**.

Single satin stitch: Embroidery stitch. See **Straight stitch**.

Single squeegee: Screen printing squeegee with one blade.

Single Stitch Zigzag, in sewing: A simple machine stitch pattern made by the needle moving up and down and alternately from one side to the other while the fabric moves through the feed mechanism in either the forward or reverse direction with all segments having equal length and width.

Single Strand Strength: The breaking strength of a single strand of yarn monofilament or cord, not knotted or looped but running straight between the clamp of the testing machine.

Single Twist: The amount of twist in each individual single yarn element in a tyre cord structure based on the length of the element after twist has been removed from the fabric.

Single yarn: See **Yarn, single**.

Single Weft Carpet: Single weft carpet is a Woven carpet, in which each row of knops is fixed in with only one weft.

Single voile: See **Voile**.

Single Yarn: The simplest strand of a textile material suitable for operations such as weaving, knitting etc.

Single Yarn: The simplest strand of textile material suitable for operations such as weaving and knitting. A singles yarn may be formed from fibres with more or less twist; from filaments with or without twist; from narrow strips of material such as paper, cellophane, or metal foil; or from monofilaments. When twist is present, it is all in the same direction. (Also see **Yarn**.)

Single-Knit Fabric: Made on knitting machines with one row of needles producing fabric that smooth and even on the right side, but uneven on the other side. The fabric is lightweight and tends to curl at the edges. Used for top and trousers.

Single-Phase weaving machines: There is a sequence in the primary motions of weaving and each of them is repeated once in each weaving cycle. The weft insertion which is the principal operation in weaving, takes place only at discrete intervals.

Single-Strand Breaking Force, in tensile testing: The breaking force of one strand that follows a specific path, usually straight line, between the clamps of a tensile testing machine.

Singling: The condition caused by the breaking of one or more strands in a plying operation with resulting unevenness in the finished product.

Singling: A yarn defect caused by the breaking of one or more strands in a plying operation with resulting unevenness in the finished product.

Singonne: Very stout, black, closely woven fullered and coarse woollen with a long nap; it sheds the water and is used in various European countries for winter clothing by the poorer classes.

Sinker: In weave design, a blank square indicating a filling thread over a warp thread at the point of intersection.

Sinker, in knitting: (holding down-knocking over): in textile terminology the sinker commonly used on plain circular knitting machines is called a 'holding down-knocking over' sinker. Its main function is to hold the sinker loop when the needle is moved from the rest position into the clearing position. It is controlled from the sinker butt by a sinker cam. It also takes over the formation of a new loop across the knock over edge (the area of the machine that the sinker loop is formed) at the end of loop formation. They have different shapes and dimensions depending on the machine type and the fabric design.

Sinker loop: this is the part of the stitch which is composed of loop feet belonging to neighbouring stitches.

Sinna Knot: See **Senna knot**.

Sinnerscher Circle: Approximate classification of the significance of four washing parameters (chemistry of the surfactants, washing time, temperature and washing mechanics) to define the cleaning efficiency of a drum washing machine.

Sipacheutoochwongyong: Black, curl pile silk velvet in China, made with serge foundation; used for hats, etc.

Sintering: Forming a bonded mass or fibre by heating the constituents of the mass or fibre without melting.

Siretz: Trade term for Russian uncleaned flax.

SIRO: "Scientific Industrial Research Organisation", Australian textile research organization

Si-Ro-Set colour fastness: Method of dyeing with Si-Ro-Set treatment, i.e. possible effect on the shade and possible staining of white wool and cotton as a result of the treatment. The dye should be selected according to the application of the finished goods, i.e., only reduction-insensitive dyes may be used in dyeing.

Si-Ro-Set process: Australian process for surface fixing and manufacturing of permanent creases and pleats on woollen articles such as trousers, skirts, etc. by treating with a solution of thioglycollic acid derivatives and subsequent shape fixing by steaming.

SiroSpun process: Process developed by CSIRO and IWS, by which a 2-ply yarn is produced at one spinning position, making twining redundant. This process allows a special spun-twisted yarn to be manufactured directly on the ring spinning machine.

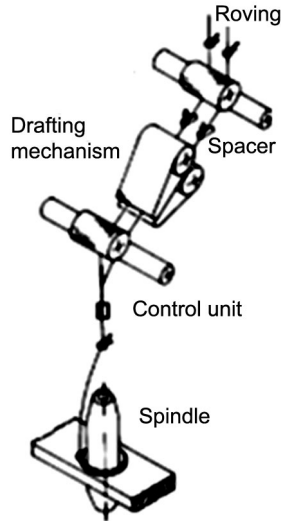

SIS: Swedish standards organization.

Sisal: Hard fibres of subtropical agave types (Mexico, Brazil, Africa, Indonesia). Named after the oldest port of exportation of Sisal in Mexico. Snow white to yellowish. Fibre bundle 60–150 cm long. Strength 35–55 cN/dtex. Not very resistant to seawater. Chemical composition: 65.8% cellulose, 10% water, 1.2% lignin, 0.3% fat and wax, 1–4% ash. Dyeable similar to Manila fibre. Application: binding yarn, cord, string, ropes, sacks, sail cloth, carpet industry, decoration materials, also for finer fabric. Sisal tow for upholstered materials.

SISIR: Singapore standards organization.

Sister's Thread: Same as **Nun's thread**.

Sistresay: From East India and Turkey, made with two warps, one silk, the other cotton, and a spun silk filling in damask patterns with coloured stripes.

Sivas carpets: Are fine, medium-size Knotted carpets from the north Anatolian city of Sivas. Warp and weft in cotton, pile in low lustre wool; the Turkish knot is used with approx. 280 000 knots/m².

Six Quarter: Goods Measuring 54 inches in width.

Sixth Combing: Wool taken from the lower part of the thigh; also called breech.

Size: In textiles, a material applied to yarns or fabrics to make them stiffer or temporarily bind fibres together. Sizing is used extensively, especially for cellulose fibres, to make them easier to process or protect them from damage during high-speed weaving or the like. A wide variety of compounds, including starches and other plant derivatives, and synthetic organic compounds, such as polyvinyl alcohol, are used for sizing. Sizing materials can interfere with dyeing, so it is important that they are removed by desizing, usually prior to scouring but sometimes as part of the scouring process.

Size, in button: A unit of measure for button diameter; one ligne is equal to 0.635 mm. (0.025 in).

Size mark: A fabric defect that consists of a rough or frosted spin caused by uneven application or drying of the size.

Size recovery: Size like PVA can be recovered by simply by washing the fabric with hot water and concentrating by suitable methods, say ultrafiltration, evaporation.

Size, Yarn: See **Yarn number**.

Sizing: A gelatinous film-forming substance in solution or dispersion, usually applied to warps but sometimes to wefts, generally before weaving. A generic term for compounds which, when applied to yarn or fabric, form a more or less continuous solid film around the yarn and individual fibre. Varieties applied to yarn (a) sizing applied to warp yarn to bind the fibres together and stiffen the yarn. (i) dope: applied to crepe yarn to set the twist and assist creping. (ii) Dressing: applied to sewing thread to bind the strands together and leave a pliable yarn. Varieties applied to fabrics include: (b) Sizing applied to fabric to improve their physical properties such as weight stiffness etc. (i) Dope: Applied to airplane fabrics to make them taut and to balloon fabrics to make them less permeable to gases. (ii) Dressing: applied to fabrics to produce a glazed lustrous effect.

Note:

- The main types of substance used are carbohydrates and their derivatives, gelatin and animal glues, linseed oil, polyacrylic acid and polyvinyl alcohol.
- The objects of sizing prior to weaving are to protect the yarns from abrasion in the healds and the reed and against each other, to strengthen them and, by the additional of oils and fats, to lubricate them.
- A size may be applied to carpets (e.g. starch) and occasionally to wool fibres (e.g. animal glue).

Sizing system, in garment construction: A method of designating garment sizes.

Sizing, Single End: The application of size to: (a) A thread supplied from a single package; the thread receives a side-traverse as it is wound on to a large drum on which it forms an endless sheet of yarn; this sheet is then cut and wound on to a beam under tension to produce a sample (or short length) warp. (b) A low density sheet of yarn in which the adjacent ends do not touch one another; the yarn is usually supplied either from a cone creel or a single warpers beam; the resulting beam is usually combined with other similar beams in a dry taping process, to produce a weavers beam(s).

Skein: A continuous strand of yarn or cord in the form of a collapsed coil. It may be of any specific length and is usually obtained by winding a definite number of turns on a reel under

prescribed conditions. The circumference of the reel on which yarn is wound is usually 45 to 60 inches. (Also see **Hank**.)

Skein: A continuous strand of yarn in the form of a flexible coil having a large circumference in proportion to its thickness.

Skein Break Factor: The comparative breaking strength of a skein of yarn adjusted for the linear density of the yarn expressed in an indirect system; the product of the breaking strength of the skein and the yarn number expressed in an indirect system.

Skein Breaking Tenacity: The skein breaking strength divided by the product of the yarn number in a direct numbering system and the number of strand placed under tension.

Skein shrinkage: A measure of true or intrinsic yarn shrinkage not including crimp contraction.

Skein strength: The force required to rupture a skein of yarn, expressed in units of force, as breaking strength.

Skeleton: Term applied to a coat made without lining.

Skene: A Highland tartan, composed as follows: Red stripe, split in the center by a green line; dark blue stripe, as wide as the red; red stripe, width and split as above; green stripe, as wide as one red and the blue stripes together; red stripe, width and split as above; green stripe, as above.

Skew straightener: A device for straightening skew distortion in textile fabrics, e.g. with the aid of rollers.

Skewness: A fabric condition resulting when filling yarns or knitted courses are angularly displaced from a line perpendicular to the selvage or side of the fabric.

Skewness: A fabric condition resulting when weft yarn or knitted courses are angularly displaced from a line perpendicular to the edge or side of the fabric in which the warp and weft yarns, although straight, are not at right angles to each other.

Skewness: The distance measured parallel to and along a selvedge between the point at which a weft yarn meets this selvedge and perpendicular to the selvedge from the point at which the same weft yarn meets the other selvedge.

Skin back: See **Broken filaments**.

Skin rug: A hand-woven Flat carpet in the form of a weft-figured carpet produced from a single weft consisting of narrow cut strips of skin at a predetermined width (also includes those rugs where the strips of skin are used in the warp with a yarn weft). The edges and ends of the rug are bonded.

Skin wool: See **Pulled wool**. Taken from the skins of slaughtered sheep, either removed by sweating, or by sodium sulphide or by lime (slipe wool). Production: as enzyme wool, as sweated wool (Mazamet wool, lime wool, slipe wool) by (a) shearing, or (b) by extraction with the hair roots, but after a prior treatment with milk of lime to dissolve the hair roots to give so-called lime wool which must consequently always be regarded as chemically damaged wool. See **Recovered wool**.

Skip: See **Float**. Flaw in cloth where a warp thread skips over more filing threads than intended.

Skip draws: The draws coming under this heading are used very extensively in silk weaving, especially for fabrics requiring a heavy warp and a large number of shafts. Enter first the odd and then the even shafts. An 8 harness draw of this kind, runs as follows: 1, 3, 5, 7, 2, 4, 6, 8.

Skipped stitch: A stitch which appears twice as long as the other stitches in a line of stitches. It is caused by failure in the stitch formation allowing the needle thread to return to the surface without being held by the bobbin (lower) thread.

Skirt: That part of a coat, dress or other garment which hangs below the waist.

Skirting: (1) In wool sorting the removal of the stained parts of the fleece, as the legs and the whole edge of the fleece; (2) Rag sorting term, meaning rags of women's dress goods and men's coat linings, containing cotton and wool.

Skyteen: A cotton shirting made in England with a five shaft, warp faced satin weave. It has stripes on a light indigo ground.

Skittery dyeings: An irregular speckled appearance in dyed goods produced by colour differences between adjacent fibres or parts of the same fibre due to a variety of causes (Skittery dyeing wool).

Slack end: (1) A warp yarn woven under insufficient tension. A warp yarn that appears puckered as the result of having been woven under less tension than the adjacent warp yarns.

(2) A warp yarn that appears puckered as the result of having been woven under less tension than the adjacent warp yarns.

Slack filling: See **Slack pick**.

Slack mercerization: A process for producing stretch in cellulosic fabrics. Mercerizing of cotton textiles on chainless mercerizing machines without tension. Fundamental requirements: suitable construction of the textile material (floating weaves), no tension during the mercerization process, the stretch effect is set by subsequent resin finishing. The process is mainly employed to produce weft stretch cotton fabrics and is sometimes referred to as “chemical stretch” or it is applied as part of the process for crease-resistant linen.

Slack pick: A single weft yarn woven under insufficient tension. See also **Loose pick**. A weft thread or part of a weft thread that has been woven into the cloth at a lower tension than the adjacent normal picks. **Slack filling**.

Slack Selvedge: Slack ends in the fabric edge. See also Baggy selvedge (Selvage), Loose edge, Stringy selvedge (selvage) Wavy selvedge (selvage).

Slack Selvage: A self-descriptive fabric defect caused by incorrect balance of cloth structure between the ground and selvage or by the selvage ends being woven with insufficient tension.

Slack Thread: See **Slack end**. A thread or pieces of thread which are slacker than the other pieces/threads.

Slack Twist: Refers to a yarn imperfection where insufficient twist is applied to the thread so it has very poor ply security.

Slack Warp: See **Slack end**.

Slaked lime: See **Calcium hydroxide**.

Slaking: See **Calcium hydroxide**.

Slam-Off, in woven fabric: A distortion due to the entrapment of the weft carrier in the shed. Compare **Smash**.

Slanting: Cross Stitch In embroidery a variety of cross stitch and but little used. The first part is same as the cross stitch, the return made like the gobelin stitch (see), can be used only on fine foundation.

Slasher: A machine on which slashing or sizing is done.

Slasher Sizing: A process by which warp yarns are sized during transfer from warpers beams onto loom beams. Two or more size boxes may be used in parallel and/or in tandem if the warp sheet is too close or effective sizing in one box or if it contains yarn with different fugitive tints.

Slashing: It is the process where size is applied to warp yarns for weaving. The purpose of size is to protect the yarn from the abrasive action of the loom.

Slat, in tufting machine: A patterning attachment consisting of two sets of inter meshing metal angular strips, (also called slats) mounted on a continuously moving roller chain. One set has a constant height whilst the other set has a profile machined according to the required pattern.

Slatted expander: Expander combinations consisting of wood laths to maintain a fabric web in the fully open-width state. Depending on requirements, the wood laths are available with or without a rubber covering.

Sleazy: Thin, lacking firmness, open-meshed; usually describes poor-grade fabrics.

Sleazy satin: A cheap, soft satin with high lustre, usually made from acetate or acetate/viscose. It is a thin fabric suitable for lining.

Sleeve: Sleeve is that part of the garment, which covers the arm portion of a body. The appearance of the sleeve can be determined by the position of the armhole, under arm seams, fullness added to any part of the sleeve and to the sleeve hem or cuff. As the arms are mobile, the sleeve should allow enough room for the movement. There are two categories of sleeves: -

- (a) **Set In Sleeves:** Cut separately from the bodice of the garment and fitted into the armhole shape. The standard set-in sleeve should smoothly cover the upper arm and shoulder socket. The armhole seam should fall on the shoulder where the socket joins the arm.
- (b) **Cut In One Piece Sleeves:** Cut in one piece with the bodice of the garment in called cut-in one sleeve, for example, Japanese Kimono sleeve, Raglan sleeve, Batwing, Dolman and Magyar sleeve.

Sleeve Cap: The curved top of the sleeve from front and back.

Sleeve center: Center of the sleeve.

Sleeve Length: The sleeves measured from the center of the neckline in the back to the end of the sleeve or cuff.

Sleeve Tacking: Stitches which attach the sleeve to the lining along the sleeve inseams and elbow seams.

Sleeve Vent: A finished slit or opening in the sleeve. Vents are usually secured by snaps or buttons at the base of the cuff.

Sleeve, Set In: A sleeve which is set into the scye.

Sleeve Lengths: *Long:* A sleeve covering the arm beyond wrist level including some portion of the hand also.

Bracelet: A sleeve covering the arm upto wrist level

Sleeve, 7/8th level: A sleeve covering the arm upto mid of the lower arm portion. Generally found in ladies tops.

Sleeve, 3/4th level: A sleeve covering the arm upto widest portion of the forearm. Generally found in ladies tap.

Sleeve, Elbow: A sleeve covering arm till elbow level. Generally found in ladies blouses.

Short: A short length sleeve covering half portion of upper arm. Generally found in summer wear.

Cap: A very short sleeve covering one-third portion of the upper arm. Generally found in ladies blouses and nightwears.

Sleeveless: It is a garment, which is without sleeve and has a finished armhole. Generally found in kids and ladies summers wear.

Sleeve, Magyar: A sleeve which is cut integrally with the body of the garment, the two sections being joined from neck to wrist. Wedge shaped pieces are inserted under the arm to allow freedom of movement.

Sleeve, Raglan: A sleeve with the armhole line extending from the front and back scye to the neckpoint so that the shoulder section is joined to the sleeve crown, eliminating the conventional shoulder and sleeve head seams.

Sleeve, Set in: The sleeve is shaped around the arm and has a seam on the underarm. The top of the sleeve, the sleeve head, is curved to accommodate the roundness of the shoulder. The sleeve is constructed and then 'set into' the bodice.

Sleeve, Bracelet/Three Quarter: This sleeve reaches half way between the elbow and the wrist.

Sleeve, Padded Shoulder: The shoulder is extended and the sleeve is heightened to accommodate a pad, to achieve a squared or rounded effect in the silhouette.

Sleeve, Raglan with Yoke: See raglan with dart. Here the raglan is extended to accommodate the top part of the bodice, achieving a 'yoke' effect. There is a seam along the top edge of the sleeve and at the underarm.

Sleeve, Dropped Shoulder: The shoulder is extended and shaped around the shoulder, rather like the capped sleeve. However there is more shaping and the extension is usually longer; also a sleeve is actually set into the armhole. The sleeve construction is modified by removing that part of the head that is now covered by the extension to the shoulder. The sleeve head then looks less curved.

Sleeve, Two Piece Tailored: A shaped sleeve that has a seam down the front and the back to allow for shaping.

Sleeve, Two Piece Tailored: A shaped sleeve that has a seam down the front and the back to allow for shaping. There is no underarm seam; consequently the sleeve is constructed in two pieces.

Sleeve, Capped: The sleeve is an insertion that just covers the shoulder point.

Sleeve, Cape: A full, flared sleeve that is set into the armhole. The sleeve could be cut as a circle to give more flare at the hem.

Sleeve, Capped (Extended Shoulder): This is an extension of the shoulder just covering the shoulder point.

Sleeve, Saddle Raglan: See raglan with dart. Here the seam for applying the sleeve to the bodice is shaped, it narrows along the shoulder line. This sleeve has a seam at the underarm and along the top edge of the arm to the wrist, including the shoulder.

Sleeve, Raglan with dart: The raglan sleeve is derived from the set in sleeve but with the shoulder added to the sleeve head. It was named after Lord Raglan who led the Charge of the Light Brigade in the Crimean War and wore raglan-sleeved jackets. This sleeve is cut in one piece but has a dart at the shoulder to accommodate the roundness of the shoulder.

Sleeve, Raglan with Seam: A normal raglan shaped sleeve with a seam along the top edge of the arm, and at the underarm. See **raglan with dart**.

Sleeve, Man's Shirt: A set in sleeve with two pleats at the buttoned cuff and a placket. Normally seen on men's shirts.

Sleeve, Long Bell: The upper part of the sleeve fits the arm, the lower part flares out into a full, bell shape.

Sleeve, Frill: The upper part of the sleeve fits the arm, the lower part has a deep, gathered frill attached at about elbow length.

Sleeve, Bell: Like the **long bell sleeve**, but much shorter, finishing around elbow length.

Sleeve, Pagoda: An eighteenth century sleeve that is fitted on the upper arm, with tiered frills on the lower part of the arm to the wrist. It can be longer at the back of the wrist. There are usually three tiers giving the appearance of a Chinese pagoda.

Sleeve, Leg of Mutton: A full, gathered sleeve head is set into the bodice and the long sleeve tapers to fit towards the wrist. Popular in the late nineteenth and early twentieth century, fashion frequently re-introduces the leg of mutton.

Sleeve, Juliet: A two-part sleeve similar in effect to the leg of mutton. The top part of the sleeve is full and gathered while the lower part of the sleeve is fitted to the arm and is seamed to the top part above the elbow.

Sleeve, Bishop: The reverse of the leg of mutton - the top part of the sleeve is fitted and then flares out towards the wrist where the sleeve is gathered onto a cuff. A popular 1960's style.

Sleeve, Peasant: A full, short sleeve that is attached to a full bodice with a raglan effect seam. The garment is drawn in with elastic or a drawstring at the neck and at the sleeve hem. There are many variations to this theme.

Sleeve, Lantern: A long set in sleeve constructed in two parts. The top part flares slightly from the sleeve head towards the wrist. The bottom part flares from a fitting wrist to meet the flare of the top. Both are seamed together a few inches above the wrist.

Sleeve, Short Lantern: The same principle as the lantern, but a much shorter version ending just past the elbow.

Sleeve, Drawstring Puffed: A full sleeve, short or long, with a drawstring to draw the sleeve to the desired size. The drawing up forms a small frill at the hem of the sleeve. Here the head is not gathered. (See also **puffed**.)

Sleeve, Draped: A set in sleeve that is slashed open at the top part of the sleeve where fullness is added; the underarm seam remains the original length. The extra fullness created is drawn up with a drawstring or elastic to fix it into place, creating a 'draped' effect.

Sleeve, Square Armhole: The armhole is shaped like a square with a right angle at the corner. The construction is as a set in sleeve.

Sleeve, Dolman/Magyar: This style is named from the Magyars in Hungary and was worn by peasants there. The shoulder seam extends through the top of the sleeve and the underarm seam follows from the side of the bodice through to the wrist. There are no other seams and any shaping is made from these two.

Sleeve, Petal/Lapped: This sleeve is cut without an underarm seam and is shaped and folded on the upper arm. It was very popular in the 1940s.

Sleeve, Mamaluke/Virago: A long, full sleeve that is partitioned into five, full sections. The five sleeve parts are drawn and seamed together to fit around the arm.

Sleeve, Strapped/Banded: The construction is that of a set in sleeve. From the neck point to the wrist is a narrow band of fabric giving a strapped effect.

Sleeve, Epaulet and Elbow Patch: A strap or tab on the shoulder, normally seen on uniforms, to carry caps. Here there is also a patch on the elbow to protect the garment and prolong its life in heavy-duty use.

Sleeve, Dolman with Gusset: See **dolman/magyar**. This dolman sleeve has a gusset set under the arm to allow for more 'lift'.

Sleeve, Kimono: A long sleeve that is a complete extension of the bodice to the wrist. The seam lines are along the top of the sleeve and at the underarm. A traditionally Japanese sleeve used on the garment with the same name.

Sleeve, Slashed Virago: See **mamaluke/virago**. This sleeve has the upper part incorporating slashing, a popular sixteenth century decorative effect. The slashing reveals the shirt or tunic underneath, giving a contrast. Here there is extra contrast with the lower part of the sleeve being constructed in a different colour or fabric.

Sleeve, Tippet on Elbow: Popular in the middle Ages. This was a pendant effect hanging from the elbow of a gown or tunic. It was similar in derivation to the liripipe.

Sleeve, Melon/Balloon: A very full, short set in sleeve, padded out to give the effect of a melon or balloon.

Sleeve, Batwing: The same principle as the kimono. This sleeve narrows towards the wrist and has a curved underarm seam. This particular example would be made from a knitted fabric.

Sleeve, Cartwheel/Circle: A short set in sleeve, designed to give an accordion effect.

Sleeve, Wing Ruffle: Like the capped sleeve but here the fabric extension has fullness added, the fabric being gathered and set onto the bodice creating a ruffle effect.

Sleeve, Bag: A long and very full sleeve that is gathered onto the cuff at the wrist. It has the effect of bagging on the lower part of the arm. This sleeve was popular in the fifteenth and sixteenth centuries.

Sleeve, Dalmatian/Angel: A sleeve that flares towards the wrist extending into a long point.

Sleeve, Buttoned Oversleeve: A medieval sleeve that has a contrasting sleeve layered over the base sleeve. The top sleeve can be unbuttoned to reveal the contrast beneath.

Sleeve, Puffed: A set in sleeve that has fullness at the sleeve head and base. It is set into the bodice and controlled at the base by a cuff or elastication to give a 'puffed' effect.

Sleeve, Double: A puffed sleeve with two layers - the base is opaque and the top sleeve is transparent to reveal the sleeve underneath.

Sleeve, Mahoitres: A 14th- and 15th-century sleeve popular in France. The sleeve is padded and bag shaped.

Sleeve, Hanging Sleeve: This is a very long sleeve that is open down the front seam and hangs vertically. It is part of a medieval gown or doublet.

Sleeve, Trailing Sleeve: This is similar to the hanging sleeve. The sleeve is constructed like a kimono and the opening for the hand is in the same position while the bottom part of the sleeve is stitched up.

Sleeving: Braided, knitted, or woven fabric of cylindrical form having a width less than 100 mm. (4 in.) [circumference less than 200 mm. (8 in.)].

Sley: The number of warp ends per inch of the fabric width exclusive of selvages.

Sleying the reed: is the placing of the warp threads through the dents of the reed. The number of dents in the reed and the number of warp threads in each dent determine the density—or sett—of the warp.

Slide surface, in rotor of an open end machine: That part of the internal surface of the rotor on which the fibres are deposited and are caused to slide to the collecting surface.

Slide Waste: A yarn defect that is similar in appearance to a slub. It consists of a mass of fibre encircling the yarn end and can be slid freely along the end.

Slider, automatic lock: See **Automatic lock slider**.

Slider, cam lock: See **Cam lock slider**.

Slider, flange lock: See **Flange lock slider**.

Slider, in zippers: The part that opens the zipper when it is moved in one direction and closes the zipper when it is moved in the opposite direction.

Slider, releasing, in Zipper: See **Releasing slider, in Zipper**.

Slider, automatic lock, in Zipper: See **Automatic lock slider.** A slider that provides automatic positive locking action on the chain when the pull is released.

Slider, cam lock, In Zipper: See **Cam lock slider, in Zipper.**

Slider, flange lock: See **Flange lock slider, in Zipper.**

Slider, flange lock, In Zipper: A slider with notches in the flanges of the slider that block the shoulders of the scoops when the stringers are pulled apart.

Slider, pin lock, in Zipper: See **Pin lock slider, in Zipper.**

Slider, ratchet locker, in Zipper: See **Ratchet locker slider, in Zipper.**

Slider, releasing, in Zippers: A slider with a mechanical means for loosening the slider on the chain.

Slip: Measure for wool, linen and jute yarns in England, equal to 1,800 yards.

Slip cover: A removable, fitted protective textile cover, often decorative and specifically made upholstered furniture.

Slip: (1) An important serviceability property of carpets, rugs, mats, etc. is that they do not slip on floors. (2) The resistance to slippage of warp over weft threads, or vice versa, in a woven fabric.

Slip stitching: Slip-stitching or invisible hemming is done on silk, wool, and thick material. The hem is pressed with an iron, a stitch as fine as possible is taken on the surface of the cloth and the needle slipped under and through the first fold, drawing the thread lightly. The needle and thread used in this stitch must be very fine.

Slip wool: See **Pulled wool.** Recovered wool obtained by treating pelts with lime and sodium sulphide or some other depilatory. This treatment loosens the wool which can then be pulled away without damaging the hide.

Slippage: Sliding or slipping of the filling threads over the warp ends (or vice versa), which leaves open spaces in the fabric. Slippage results from a loose weave or unevenly matched warp and filling.

Slipper Carpet: Warp-pile fabric made with coloured Jacquard figures, used for bags, slippers, etc.

Slipper satin: A closely woven satin made from good quality yarns, which make it hard wearing. It is less glossy than other satins due to the closeness of the weave, and a more elegant fabric because of this. It is used chiefly for footwear. Textures are high and the material comes coloured, black or white, or richly brocaded effects. Shiniest satin.

Slit tape: A fabric, 12 inches or less in width, made by cutting wider fabric to the desired width. Slit tapes are made primarily of cotton, linen, jute, glass, or asbestos and are used principally for functional purposes.

Slit-film yarn: Yarn of a flat, tape-like character produced by slitting an extruded film.

Sliver: A continuous strand of loosely assembled fibres that is approximately uniform in cross sectional area and without twist.

Sliver knitted fabric: A single jersey fabric in which untwisted staple fibres are knitted in at each loop to form a pile surface on the technical back of the jersey structure.

Sliver knitting: Circular knitting coupled with the drawing-in of a sliver by the needles to produce a pile-like fabric, usually for high-pile coats or heavy linings.

Slop Padding: A printing process used on chintzes and some calicoes. The fabric is first printed with resist after which the colour is applied to the entire face of the cloth by means of an unengraved roller.

Slope threshold: In this method the slope of the initial linear region is determined, and the point where the slope of the curve decreases to a specified fraction of the initial slope shown.

Slops: Baggy, overhanging knee or calf length breeches, often having lengthways slashes with protruding lining.

Slot seam: A complex seam formed on the inside of the object, having a decorative seam underlay slightly visible from the face side held in place by two visible rows of stitching. A slot seam allows you to place a matching or contrasting fabric underlay behind the edges of the seam.

Slot seam: A complex seam formed on the inside of the object, having a decorative seam underlay slightly visible from the face side held in place by two visible rows of stitching. The slot seam, used in cloth dresses and jackets, requires exact basting with silk or very fine thread with small, even stitches. If a coarse thread is used, the material will be badly marked. After basting, press the seam open as if it had been stitched, and baste the strap or under strip of the dress material (which has been cut perfectly straight and even) over the wrong side of the seam, having the center of the seam on the center of the strap. Stitch any width desired beyond the center through the three thicknesses. This will hold the seam in position. Now remove the bastings from the seam and the slot effect is complete. If desired, there may be a double

row of stitching, an extra row on the edge of the fold or plait. These seams may be finished at the bottom with arrow heads or stitched designs. The lines of machine stitching should not end without some ornament to *appear* to hold the plait.

Slough off: See **Slug**.

Sloughed filling: See **Looped filling**.

Slough-off, in woven fabrics: A defect caused by several coils of yarn slipping of the weft bobbin simultaneously and being woven into the fabric in a group.

Slow sand filter: One of the earliest filters for water treatment, developed in 1829 by James Simpson. It has a sand layer up to 1.0 m deep over a layer of gravel about up to 0.3 m deep. Perforated concrete or clay underdrains laid in the gravel remove the filtered water. The D10 *effective* size of the sand is 0.2 to 0.4 mm, with a *uniformity coefficient* of 1.6 to 2.5. The sand is drowned under about 1 m of water. The filter is cleaned every few weeks or months by draining the water and scraping off the top 15 to 25 cm of sand. This is repeated until filtration is no longer efficient, and the sand bed is then renewed. Slow sand filters are capable of removing tastes, odours, some bacteria and some protozoa from the water. The *surface loading rate* is 2.5 to 7m³/d per m² of filter surface area. In wastewater treatment, slow sand filters can be used for tertiary treatment with a surface loading less than 10m³m⁻²d⁻¹.

Slub: A abruptly thickened place (in a spun yarn) that has tapering ends and a diameter several times that of the adjacent normal yarn which is irregular and at several places along the length of the yarn, causing the fabric to have a surface interest and broken texture. A yarn defect consisting of a lump or thick place on the yarn caused by lint or small lengths of yarn adhering to it. Generally, in filament yarn, a slub is the result of broken filaments that have stripped back from the end to which they are attached. See **Slug**. Many yarns slub is an imperfection, but slub yarns are deliberately manufactured in other fibres as cotton, polyester, acetate, viscose and their blends. The resulting fabric may be of medium or heavy weight.

Slub Catcher: A mechanical or electronic device designed to aid in the detection and removal of slubs or neps in yarns, usually during coning.

Slub Fabrics: Fabrics made using slub yarn, mainly in knitted fabric form.

Slub silk: Silk yarn with nubs or balls of fibre at intervals. It is woven into fabric with an interesting surface structure. The fabric is usually dress weight and often crisp.

Slub Yarn: Any type of yarn that is irregular in diameter; the irregularity may be purposeful or the result of error. (Also see **Novelty yarn**, **Nub yarn**, and **Slub**.)

Slubber: A machine used in textile processes prior to spinning that reduces the sliver and inserts the first twist.

Slubbing: The name given individually or collectively to relatively thick fibrous strands and also to the strips of web from a condenser card that have been consolidated into a circular cross section by rubbing.

Sludge: Solids settled out from water or wastewater, but still containing high percentage of water. Sludge from wastewater treatment is known as *biosolids*.

Sludge blanket: The mass of sludge in a *sedimentation tank* or *clarifier*. The bottom of the blanket may rest on the bottom of the tank or it may be a suspension, as in the *sludge blanket clarifier*. The *settling regime* of the sludge blanket is either zone settling or compressive settling.

Sludge blanket clarifier, floc b. c., upward flow c., upward flow floc b. c.: A type of *solids contact clarifier* in which the inlet flow passes up through the suspended *sludge blanket*. The particles from the coagulated water are ‘filtered’ out by and amalgamate with the blanket. When the sludge level rises too high, some sludge is wasted from the tank. The top of the sludge blanket must be well beneath the top water level. The clarified water flows over weirs at the surface of the clarifier. The *surface loading rate* may be 40 to 120m³/d per m² of tank surface area, depending on the quality of the inlet water.

Sludge cake: Sludge that has been thickened to 80% can be picked up with a shovel and is called cake. *Filter plate presses* can reduce water works and wastewater sludges to less than 70% water. *Belt filter presses* and *centrifuges* can reduce wastewater sludges to about 75% water.

Sludge digestion: Usually *anaerobic sludge digestion*. a treatment that stabilises *raw sludge*. Fully *digested sludge* has little readily biodegradable organic matter. It is not smelly and about 50% of the solids are inorganic. Sludge can also be digested aerobically. See *aerobic digester*.

Sludge hopper: The lowest part of a *sedimentation tank*, where the settled sludge collects, either by flowing or being scraped in. This deep part is at the centre of an *upward flow tank* or *radial flow tank* and usually at the inlet end of a *horizontal flow tank*. Its capacity, in *primary sedimentation*, should be 1.4 litres per person, which should provide enough space for 24 h *sludge production*. With sides sloping at 60 ° to the horizontal, it should be deep enough to ensure some consolidation of the sludge by compression settling.

Sludge production: (1) The mass of *primary sludge* accumulated per day in wastewater treatment is estimated by multiplying the wastewater flow by its concentration of suspended solids and by the percentage removal of solids in the *primary sedimentation* tank (typically 60%). (2) *Secondary sludge* production is often stated as the number of kg of sludge produced per kg BOD₅ removed or applied to the *secondary treatment*, a figure sometimes known as the sludge growth index. For standard rate *trickling filters* it is about 0.7. For *activated sludge* it is about 0.75 at a *F:M ratio* of 0.4 per day and may drop to 0.4 at a F:M of 0.1 per day.

Sludge thickening: The difference between two sludges that are, respectively, 98 and 94% water is that the first, at 2% solids, occupies three times the volume of the second for the same weight of dry solids. Therefore, thickening gives good reductions in volume for small increases in solids content. Sludge may be thickened by a variety of techniques. *Gravity thickening* is common. *See belt thickening, centrifuge thickening, deep cone thickening, dissolved air flotation, rotary drum thickening.*

Slug, in glass filament: Unattenuated particles of glass of substantially larger diameter than the average filament diameter.

Slug, in raw silk: A thickened place several times the diameter of the yarn, 3 mm (1/8 in.) or over in length.

Slug general: An abruptly thickened place in the yarn or a bunch of lint entangled in the yarn, cord, or fabric.

Slurry: A watery or solvent suspension; e.g., titanium dioxide mixed with water for addition to polymers.

Small Chain: The binder warp in certain carpets, as Wilton or Brussels.

Smart packaging: A smart packaging is one that is able to sense and respond to a stimulus for a specific functional purpose. The term ‘functional purpose’ is key here, and responses that are purely aimed to be a visual effect – such as the use of thermochromic inks for visual impact only – are not considered to be within the remit of this section. They are however notable for providing design differentiation.

Smart Textiles/Smart clothing: Smart clothing is a “smart system” capable of sensing and communicating with environmental and the wearer’s conditions and stimuli. Stimuli and responses can be in electrical, thermal, mechanical, chemical, magnetic, or other forms. Textiles that can sense and react to changes in the environment, such as changes from mechanical, thermal, chemical, magnetic and other sources.

Smash, in woven fabric: A relatively larger hole in the cloth characterized by broken warp ends and floating picks. Compare **Slam-off**.

Smash: A relatively large hole in a fabric and characterised by many broken warp ends and floating picks, or a prominent mark that remains after the repair of such a hole.

Smear prints: Are formed by inadequately ground doctor blades in roller printing so that the print paste is insufficiently removed locally next to the engraved areas of the roller. The problem can be remedied by regrinding the doctor blade and/or by adjusting the position of the doctor blade against the printing roller.

Smoke Chamber Test, for carpet: Test method to measure smoke generation of carpet.

Smoking Jacket: A fancy coat for house (smoking) wear.

Smoldering: The combustion of a solid material without accompaniment if flame but generally with the production of smoke.

Smooth backing: (smooth coat). A smooth, less structured, back-coating with a lower degree of foaming applied to textile floorcoverings for the purpose of achieving good resistance to slippage and cutting.

Smooth foam backing: (flat foam). A smooth, non-structured, foam carpet back coating.

Smoothen, to: A term used in laundering for Mangling and Pressing. In wool finishing, the term is used for steeping (wet setting, crabbing).

Smoothing agent: is a special type of textile softener in which the smoothing effect is based on reducing friction between individual fibres or particles of finishing agents. Cationic products are more effective as smoothing agents than anionic or non-ionic products.

Smoothing and calibrating calendar: A special calendar for the thickness calibration and surface smoothing of needle felt nonwoven filters for liquid media.

Smoothness appearance: A subjective assessment criterion for the appearance of textile surfaces, especially for durable-press (DP) articles after household washing. The smoothness appearance is assessed by comparison with 3-dimensional standards (Wash and- Wear Standard, DP-Rating and the Monsanto Crease Formation Standards as photographs).

Smoothness effect: Smoothness appearance.

Smoothness number: This may be defined as the relative fibre-to-fibre resistance to friction where a low smoothness number corresponds to a

smoother effect achieved by the application of Smoothing agent. The untreated fabric, smoothness number = 100.

Smouldering: A slow, flameless, smoking burning of a fabric.

Smyrna: Greek cotton, having a medium v strong, harsh and fairly clean staple of dull white colour.

Smyrna Carpets: (1) A general trade name for Turkish carpets exported to Europe via the Turkish port of Smyrna (today's Izmir). These were usually copies of other well-known types of Turkish carpets produced in designs to satisfy European and American preferences and were often woven with inferior materials with a relatively low knot density. They were made principally in Ushak, Isparta, Sivas and Smyrna itself. (2) Coarse, soft, not very durable, deep-pile Medallion carpets of Greek origin.

Smyrna Rugs: (1) trade name for Turkish rugs made in Asia Minor and marketed through Smyrna; (2) in America, factory-made reversible rugs and carpets, made with chenille filling.

Snag, in fabrics: A yarn or a part of a yarn pulled or plucked from the surface.

Snag: (1) Yarns, fibres or filaments in the form of long loops that have been drawn out from the structure of a fabric by a protruding sharp object.

(2) A textile defect caused by (or due to) the pulling or plucking of yarn(s) or filaments from the fabric surface.

(3) A loop which has been pulled out of fine-knit hosiery due to the smoothness of the fibres (ladder). Drop stitches in smooth weft-knit fabrics are wales which, as a result of a broken thread or needle damage, are present as unformed threads.

(4) (pulled thread), a slub-like structure consisting of individual capillary fibres, 2–8 mm in length, which has been pulled out of the whole thread. It occurs mainly with polyamide yarns and knitted fabrics (hosiery).

Snagging resistance, in textile fabrics: The resistance to the formation of snags.

Snap: See **Snap fasteners**.

Snap action, in: The force required to disengage a snap fastener resulting from a pull in the plane parallel to the material which the snap fastener is attached.

Snap fastener: A device for attaching one material to another consisting of matching male and female parts, each of which is attached to a separate material so that the parts can be joined by a low compressive force and separated by

a low perpendicular tensile force. Small snaps (size 4/0 through 1/0) are for light weight fabrics and large sizes (1 through 4) are for heavy ones.

Snarl, See **Kink**.

Snarl: A short length of warp or weft yarn that has twisted on itself owing to lively twist (see twist liveness) or insufficient tension. The snarling may occur during or prior to the weaving process.



(a)

(a) Snarled Yarn

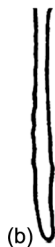

(b)

(b) Twist Free Yarn

Snicks: Flaws in the yarn, consisting of very thin places.

Snow Ball: See **Fuzz ball**, **Balling up**.

Snow cloth: The term used to describe any heavy outdoor cloth, particularly those with nap or pile.

Snubber Pin: A stationary pin or guide which induces a localized change in yarn tension. A draw pin is a type of snubber pin.

Soaking: Treatment of rayon yarns in a lubricating and sizing solution preparatory to hard twisting.

Soap: A substance consisting of sodium or potassium compounds of fatty acids used to improve the cleansing properties of water. Soap is a surfactant and was the earliest known detergent. Alkali salts of fatty acids with a minimum of 12, and a maximum of 18, carbon atoms. The first signs of surfactant properties are already apparent from 8 carbon atoms upwards. The hydrophilic part of an anionic surfactant is due to the presence of COO⁻ groups, and the hydrophobic part is due to the presence of an alkyl residue, e.g. sodium stearate C₁₇H₃₅COONa, sodium oleate, used as a cleaning agent. The basic method of making soap involved treating animal fat (mainly beef tallow), which is a triglyceride of octadecanoic acid (stearic acid), with caustic soda (sodium hydroxide; NaOH) to produce sodium octadecanoate (sodium stearate). More refined soaps are made from vegetable oils, such as palm oil, which contains hexadecanoic acid (palmitic acid). Liquid soaps (*soft soap*) are made using potassium hydroxide rather than sodium hydroxide.

Soap Flakes: They are actual small pieces of hard soap. Soap Flakes are produced from dried, cut, hard soap.

Soap Handle: The preferred handle for worsted yarn wool fabrics which, in former times, was achieved by using soap in scouring and milling.

Soap powder: Dried, pulverized Soap (produced from soap paste and sodium carbonate) with a total fatty acid and resin acid content of 5–40%.

Soap residues: (fatty residues). Coarse agglomerated residues of soap, fat, lime salts, and dark pigment soils, often appearing as numerous spots which are deposited on garments during washing. They are caused by using a soap with an excessively high fat content or (usually) by carrying out the first rinse with cold water. They can be eliminated by using Syndets or a slightly acidic rinse water.

Soaper: See **Soaping Machine**.

Soaping: (or soaping off) - with respect to dyeing, the process of washing dyed fabric with very hot (often boiling) water with surfactants, rarely actually soap, to remove dye that is not fixed to the fibre. Soaping off is important particularly with some reactive dyes, since a good deal of hydrolyzed dye is loosely bonded to the fabric, and must be removed to avoid staining of other garments or fabric in laundering. Soaping is also important in vat dyeing, where there are actual changes, including in hue, in the dye in the fibre. Though surfactants are often used, they may actually contribute almost nothing to the effectiveness of the process.

Soaping Machine: This type of machine consists of a vat with squeeze rolls for wetting out wool piece goods that only require a short milling treatment. When the addition of milling agent is made by pouring it into the machine, this does not result in satisfactory distribution of the product.

Soapstone: A soft type of talc which has a greasy feel and which is easy to carve to make ornaments. It was formerly known as steatite. See **Stearite**.

Soda : See **Sodium Carbonate**.

Soda Ash: Sodium carbonate; an antiquated but much-used term.

Soda-ash boil: The type of alkali used for scouring of cotton depends on the quality of goods.

For example, if coloured yarns present in the fabric, sodium carbonate is ideally suited because of its low pH. Cotton yarns to be dyed in dark shade should be scoured with 1–2% sodium carbonate solution for 30 min in presence of wetting agent.

Soda cellulose: (alkali cellulose). Represents the first stage in viscose rayon manufacture. Cellulose pulp is steeped in warm caustic soda liquor (17–18%)

for 1–2 h, and then pressed to remove excess solution. The treated cellulose is broken up in a shredder to form powdery crumbs. The crumbs are then aged for several hours during which time the caustic soda reacts with the cellulose to form soda cellulose.

Soda lime: A gray solid produced by adding sodium hydroxide solution to calcium oxide, to give a mixture of Ca(OH)_2 and NaOH on evaporation. It is used in the laboratory as a drying agent and as an absorbent for carbon dioxide.

Sodalite, cage zeolite: A blue, grey, yellow or colorless mineral consisting essentially of sodium and aluminium silicates with sodium chloride in a cubic crystalline form of the type $\text{Na}[\text{Cl}(\text{AlSiO})]$, which occurs in certain basic igneous rocks. The hollow structure of sodalite is important as a lattice unit in Zeolites.

Sodium Acetate: CH_3COONa ; a buffer 3 In dyeing, sodium acetate is almost always used together with acetic acid in moderately acid processes (that is, sodium acetate is rarely used without acetic acid, but acetic acid may often be used without sodium acetate). molecular weight 136. Colorless odourless crystals or anhydrous salt. Solutions in water are weakly alkaline. Uses: neutralization of mineral salt esters on cellulosic textiles; reduction of acetic acid acidity (buffering); neutralization of naphthol diazo solutions; aftertreatment of sulphur black (prevents tendering); additive for diazo solutions in dyeing and printing with naphthols, etc.

Sodium alginate: Sodium salt of Alginic acid, $\text{C}_{10}\text{H}_{18}\text{O}_{10}(\text{COONa})_2$; soluble in cold resp. warm water under rapid stirring (it is advisable to allow freshly prepared solutions to stand overnight). Boiling in water reduces the viscosity. Solutions are non-foaming. Stable to alkalis but sensitive to acids (especially below pH 3). The addition of a complexing agent (5–25% of the weight of alginate) is recommended in hard water. Solutions are sensitive to bacterial decomposition (the addition of 0.2% salicylic acid, formaldehyde, etc. can be used as a preservative). Uses: sizing agents, finishing agents, water-repellent impregnations. The main use of sodium alginate is as a thickener for textile printing (discharge pastes, roller and screen printing, easy to wash off, uniform viscosity, excellent penetration in printing, non-foaming, flows readily, good colour yields, sharp outlines). Suitability as a thickener for textile printing: especially important for reactive dyes, azoic diazo dyes, vat leuco ester and vat dyes; not suitable for cationic dyes, chrome dyes and naphthols.

Sodium aluminate: (aluminate of soda). Na_3AlO_3 or Al(ONa)_3 , molecular weight 144.25. Colorless small lumps or fine powder with 35% Al_2O_3 (stable to air) or 50% Al_2O_3 (somewhat hygroscopic, store in airtight containers);

both forms are readily soluble in water. Uses: waste water treatment, water softening, oil removal from feed water and desilification; mordant for dyeing alizarin red (on cotton), etc.

Sodium Bicarbonate: NaHCO_3 ; more properly called sodium hydrogen carbonate; also called sodium acid carbonate, and most commonly, baking soda. Sodium bicarbonate is used as a weak base (alkali) in some dyeing processes, often with reactive dye that is padded onto fabric, then batched for many hours. It has limited stability in solution, decomposing to sodium carbonate, carbon dioxide and water, especially at high temperature, so solutions generally should be made shortly before use. Sometimes this decomposition is used deliberately, usually with highly reactive dyes such as MX. A print paste made with sodium bicarbonate will have a pH around 8, and at this pH the dye will not hydrolyze rapidly and hence become useless. When the printed fabric is steamed, the sodium bicarbonate will decompose and the pH will rise to around 11, facilitating reaction of the dye with the fibre.

Sodium Bisulphate: NaHSO_4 ; also called sodium hydrogen sulphate or sodium acid sulphate. Sodium bisulphate hydrolyzes in water solution, and acts much like sulfuric acid. It can sometimes be used as substitute for sulfuric acid, and because it is a dry chemical, it can be safer to handle, though care is still necessary. Sodium bisulfate is often the basis for etchant pastes for devoré of cotton. "pH Down" for spas and swimming pools is usually sodium bisulfate. Do not confuse this with sodium bisulfite.

Sodium Bisulphite: NaHSO_3 ; a mild reducing agent, most used in dyeing as an antichlor; often actually sodium metabisulfite ($\text{Na}_2\text{S}_2\text{O}_3$), which behaves the same way. As an antichlor, sodium (meta)bisulfite reacts with sodium hypochlorite and hypochlorous acid, to almost immediately stop bleaching action. The product of the reaction is two acids which need to be thoroughly rinsed from the fabric. Typical use is about a gram (approximately 1/4 tsp) per litre of room-temperature water. Solutions should be prepared shortly before use (preferably within an hour) and with gentle stirring, since oxygen dissolved in the solution will destroy its effectiveness. Discard used solutions. Do not confuse this chemical with sodium bisulphate.

Sodium borate: (borax, sodium tetraborate, sodium pyroborate). $\text{Na}_2\text{B}_4\text{O}_7 \cdot 10\text{H}_2\text{O}$; molecular weight 382; density 1.7. White crystals or anhydrous powder. Soluble in water; the solution is fairly strongly alkaline. Uses: mild alkali, textile printing, application of alkali blue (wool dyeing); manufacture of hat proofs; addition to finishing liquors (as a preservative); solvent for alizarin dyes and casein; flame-retardant impregnations; component in soaps and gloss starches; flux.

Sodium Carbonate: soda ash; Na_2CO_3 ; a weak base Sodium carbonate is an extensively-used alkali in textile preparation and dyeing. It is typically used to adjust the pH of solutions to about 11. It is also used in scouring cellulose fibres. The most common industrial form is the anhydrous type. Sodium carbonate monohydrate ($\text{Na}_2\text{CO}_3 \cdot \text{H}_2\text{O}$) is the most common form sold for photographic use. Washing soda, if “pure”, is usually sodium carbonate decahydrate ($\text{Na}_2\text{CO}_3 \cdot 10\text{H}_2\text{O}$). Soda ash is hygroscopic, so it should be stored in a tightly-closed moisture-proof container. If so protected, it will keep indefinitely.

Sodium Chlorate: NaClO_3 (chlorate of soda) An oxidizing agent, sometime used as a *resist salt* to protect dyes from reduction in printing processes under acid conditions. Molecular weight 106.5; density 2.5. Colorless crystals, hygroscopic, toxic; water-soluble. Textiles moistened with sodium chlorate are readily ignitable. Uses: powerful oxidizing agent especially in textile printing and aniline black dyeing.

Sodium Chloride: NaCl ; common salt Sodium chloride is used in large quantities as an electrolyte in application of direct dyes and reactive dyes

Sodium chlorite: NaClO_2 ; molecular weight 90.5; white crystals or crystalline powder, odourless, very stable product. Acidic solutions decompose very rapidly: Uses: bleaching agent for cellulose (chiefly linen and cotton), cellulose pulp, paper, cupro, acetate and viscose fibres, as well as polyamide, acrylic, polyester and polyvinyl chloride fibres, waxes and straw products, edible and inedible oils, etc.; oxidation of vat and sulphur dyeings.

Sodium Chlorite Bleach: (1) Cellulosic fibres: sodium chlorite produces excellent bleaching effects with a high degree of fibre protection. It can be applied by full bath treatments or by discontinuous and continuous padding methods. Bleaching reaction only proceeds quickly enough in acidic media below pH 5. Damage to the fibre can occur at $\text{pH} < 3$. For full bath bleaching, organic acids (acetic or formic acid) are preferred to adjust the pH. In addition, diammonium or sodium phosphate are added as stabilizers. In pad-steam processes, organic acids are substituted by products which split off acids by the action of heat, i.e. so-called activators (e.g. ethyl acetate, chloral hydrate). (2) Synthetic fibres: with the exception of polyurethane and some individual acrylic fibre types, the sodium chlorite bleach is the suitable bleach for synthetic fibres in which the material is treated exclusively in a long liquor.

Sodium Dithionate: sodium hydrosulfite; dithionite is technically more correct. Uses: the most important reducing agent for stripping dyeings; reducing agent for the dyeing of vat, indigo and sulphur dyes; reducing agent for the printing of vat dyes by the 2-phase process; bleaching agent (especially for wool); antichlor; spotting agent (for dye, fruit, perfume, rust and ink stains,

perspiration, etc.). Sodium dithionite-formaldehyde compounds (so-called sulphonylates) are used for stripping dyes, and as more stable reducing agents for the dyeing and printing of vat dyes, and discharge printing.

Sodium Formaldehyde Sulphonylate: A reducing agent used in discharge techniques and for stripping dye; Formosul and Rongalit C are trade names; designated in Colour Index as Reducing Agent 2 This chemical is useful for discharge on cellulose and silk, but not usually on wool. It requires alkaline conditions that may damage wool (alkaline conditions can also reduce the sheen of silk). It does not contain free formaldehyde. Also see zinc formaldehyde sulphonylate.

Sodium Hexameta Phosphate: $\text{Na}_{(x+2)}\text{P}_x\text{O}_{(3x+1)}$, where $x = 6$ to 21 ; a *sequestrant* used to treat hard water; SHMP, often referred to in art dyeing literature as “metaphos” Sodium hexametaphosphate softens water by sequestering calcium and magnesium, effectively making them unavailable to participate in other reactions. Typical use would be about 0.5 grams per litre of water. Calgon T is one trade name for sodium hexametaphosphate, though retail Calgon products contain other chemicals, and are not the preferred products for dyeing applications.

Sodium Hydrosulphite: $\text{Na}_2\text{S}_2\text{O}_4$; a reducing agent used in discharge techniques, dye stripping, and in vat dyeing; more properly called sodium dithionite; dyehouse term is “hydro” or “hydros” For stripping, it is usually used in an alkaline solution at a temperature near the boiling point of water. This is the active ingredient in some of the “whiteners” or “dye removers” sold in small packages like the “household” dyes in the grocery store. It produces a rather strong sulfurous smell. Sodium hydrosulphite is a flammable powder, and must be handled with care. Do not confuse this with sodium hydrosulphide, which is used with sulfur dyes.

Sodium Hydroxide: NaOH; a strong base; commonly sold as beads or flakes, or as a 50% solution; also called caustic soda or lye, often just called “caustic” in dyeing Sodium hydroxide is used in some dyeing processes requiring very high pH. A solution of 4 grams per litre will have a pH of 13. It is common in vat dyeing, some reactive dye methods, and is used in mercerizing cotton. It is commonly used for industrial *scouring* of cotton. Sodium hydroxide must be handled with great care, since it will cause severe skin burns. It should be dissolved by SLOWLY adding it to stirred VERY COLD water, since a great deal of heat is liberated as it dissolves. Never use aluminum vessels or tools with NaOH: they will be corroded, and explosive hydrogen will be generated. Sodium hydroxide is deliquescent - extremely hygroscopic.

Sodium Hypochlorite: NaOCl Household type chlorine laundry bleach contains about 5% sodium hypochlorite as the active ingredient. Stronger

solutions are available for industrial use. See bleach, chlorine. Normally used as the hypochlorite lye: clear, yellow-green, free from calcium salts, stabilised (stable for cool storage during months); density 1.21–1.23 with 140–160 g/l active chlorine, equivalent to 147–168 g/l NaOCl.

Sodium Hypochlorite Bleach: In comparison to Calcium hypochlorite has an advantage in the absence of calcium, hard water salts. Therefore easier rinsing, weaker acidification (cost), softer fabric handle, also retains white effects better and helps to avoid local fibre damage by calcium chlorite particles. Clear disadvantage: AOX loading in effluent.

Sodium Hypophosphite: The most effective catalyst for promoting Durable Press properties. DP rating and shrinkage control equivalent to DMDHEU have been obtained. Catalyst is expensive higher than normal amounts are needed. The hypophosphite is a reducing agent. This is beneficial for maintaining white fabrics, however, it discolors certain dyes especially sulfurs.

Sodium m-nitrobenzene sulphonate: Often referred to by BASF's tradename Ludigol®. This chemical is a mild oxidizing agent that is sometimes used to protect dyes from degradation caused by reducing conditions that exist at high pH and high temperature, especially where air is excluded from the dyeing vessel. Such conditions are quite common in processes for some of the low-reactivity dyes, but very rare in processes for MX dyes, except in steam fixing. Recommended amounts for protecting dyes from reduction range from 1 to 10 grams per litre of dyebath. When used in printing it is sometimes called a resist salt. It is also used as an oxidizing agent for some vat dyes.

Sodium Metabisulphite: See **sodium bisulfite**.

Sodium m-nitrobenzene sulphonate: Used to inhibit the reductive effects of caustic and soda boiling, (bleaching dyed goods), as reserving agent for vat dyestuffs in discharge printing and similar methods.

Sodium N-benzylsulphanilate: Fine white to yellowish powder, easily soluble in water with neutral reaction. Extensively used in dissolving hydrotropic dyestuffs and as a dispersing agent, especially for vat and leuco-vat dyestuffs in printing: effective as a leveling agent, increases the yield and improves fixation.

Sodium nitrite: (nitrite, saltpetre). NaNO_2 ; molecular weight 69; density 2.17, white to pale yellow crystals, weakly hygroscopic, easily soluble in water, slightly soluble in alcohol. Applications: Diazotising azo dyestuffs (1 part sodium nitrite and 3 parts nitric or sulphuric acid; ratio is important to produce the required nitrous acid); dyeing with leuco-vat dyestuffs; in printing, etc.

Sodium number (SN): Expression for the required minimum alkalinity (to avoid hard water deposits) of feedwater in mg/l of NaOH. Calculation:

$$\text{SN} = \text{mg NaOH} + 0.222 \text{ mg Na}_2\text{CO}_3 + 0.667 \text{ mg Na}_3\text{PO}_4 \cdot 12\text{H}_2\text{O} + 0.222 \text{ mg Na}_2\text{SO}_3.$$

Sodium Perborate: NaBO_3 This is the bleaching compound that is most commonly found in laundry detergents that contain “colour safe” bleach. Such detergents often contain special activators that make the perborate work more effectively at moderate temperatures.

Sodium Percarbonate: A dry chemical made by reacting sodium carbonate with hydrogen peroxide Sodium percarbonate can be used as an alternative to hydrogen peroxide for oxidizing bleaching. It is considerably more expensive, but is safer to handle (relative to industrial-strength hydrogen peroxide). Oxi Clean[®] is a retail cleaning compound believed to be primarily sodium percarbonate.

Sodium peroxide: (sodium superoxide). Na_2O_2 ; molecular weight 78; density 2.81. Pale yellow, fine particulate powder (or compact granules of 0.3–1.5 mm \varnothing) 19–20% active oxygen, very hygroscopic, odourless; 97% purity. Application: Oxidizing agent for vat and sulphur dyestuffs; bleaching agent for silk, wool, cotton, linen, viscose, etc.) In soluble form after the addition of sulphuric acid (to neutralize) and addition of phosphate to make weakly alkaline, stabilizer etc. to produce a non-yellowing full white product (softer fabric handle and less fibre damage).

Sodium Phosphate: Primary sodium phosphate (monosodium phosphate, sodium dihydrogen phosphate) NaH_2PO_4 . Not as effective in promoting DP ratings. Requires higher temperature cure. Much less expensive than hypophosphite. Discolors whites at higher temperatures Does not affect dye shade. Application: Water preparation especially for boiler feed as corrective method after base exchange. Dosing ca. 20 g. sodium phosphate crystals/m³/l^o hardness whereby there is a minimum 1^o carbonate hardness from sodium hydrogen carbonate. II. Secondary sodium phosphate (disodium hydrogen phosphate). $\text{Na}_2\text{HPO}_4 \cdot 12\text{H}_2\text{O}$; density 1.53; molecular weight 358. Application: Water preparation especially for boiler feed (60 g/m³ and residual hardness) especially after the softening stage; weighting of silk, dyebath additive as a mild alkali (substantive sulphur dyestuffs), fixing agent for aluminium mordant (alizarin red), flame retardant impregnation, builder for laundering detergents. III. Tertiary sodium phosphates Trisodium phosphate.

Sodium sesquiphosphate: $\text{Na}_3\text{H}_3(\text{PO}_4)_2$. Known as a polyphosphate; changes on heating to a neutral mixture of alkaline mono-phosphates at 300–500°C. Application: as detergent and boiler de-scaling agent.

Sodium Silicate: $\text{Na}_2\text{Si}_3\text{O}_7$ and similar compounds, usually as a solution in water Sodium silicate is used as a stabilizer in hydrogen peroxide bleaching. It can also be used in direct application of reactive dyes to cellulose fibres. Here it is applied essentially full-strength after the dye is applied, acting as an alkali to cause the dye to fix to the fibre. Because it is a syrupy liquid, it makes the dye spread less than other postapplied alkalies. Care must be taken to avoid making solutions of sodium silicate acidic, since this will result in a water-insoluble gel that is extremely difficult to remove. Sodium silicate solution is also called water glass. It can be very irritating to skin. Application: Degumming of silk; caustic and keir boiling; stabiliser for peroxide bleaching; silk weighting; dyeing of alkali blue (wool); flame retardant impregnation; in printing; matting of viscose; soaping assistant; component in washing powder and liquid soaps; adhesives, etc.

Sodium Sulphate: Glauber's salt; Na_2SO_4 , molecular weight 142; density 1.46. Sodium sulphate is used as an alternative to common salt (sodium chloride) in some dyeing processes, such as those involving MX turquoise where it is a simple electrolyte. When used with some acid dyes for wool, it may act as either an electrolyte to enhance exhaustion, or as a retarder to aid leveling, depending on conditions such as pH. It is also used as a diluent for many dyes. Sodium sulphate is often sold in anhydrous form. It will absorb water from the air, so it should be stored in tightly closed containers. In the dye industry, some use "sodium sulphate" only to refer to the anhydrous form, known as "Duisburger sodium sulfates", white powder, iron free and 99.5–99.8% pure, water soluble with gentle heating and "Glauber's salt" to refer to the decahydrate form ($\text{Na}_2\text{SO}_4 \cdot 10\text{H}_2\text{O}$) is colorless crystals of high purity, easily efflorescent, water soluble with temperature lowering. Application: Salt in the dyehouse (neutral baths: like sodium chloride for salting out dyestuffs, increases dyestuff rate of exhaustion; acid baths: reducing acidity, slows the rate of exhaustion of dyestuffs); in standing baths for increasing the salt content and raising the boiling point; component in many powderform dyestuffs (diluent); additive in weighting formulations, etc..

Sodium stannate: (preserving salt, tin soda). $\text{Na}_2\text{SnO}_3 \cdot 3\text{H}_2\text{O}$; molecular weight 267. Easily water soluble crystals, solution (hydrolysed) strongly alkaline. Used as a swelling agent e.g. for viscose filament yarn (by diffusion of salt solution into the fibre) and, by thermal decomposition for the stabilising and storage of stannic acid gels (similar effect and improved by a treatment with barium chloride solution with the formation of barium stannate), as matting pigments. Application: weighting of silk; flame retardant impregnation (textile finish); matting of viscose.

Sodium stearate: (sodium salt of stearic acid). $C_{17}H_{35}COOH$ molecular weight 306.46. Saponified stearic acid. White flakes; soluble in water and alcohol. Application: manufacture of household soaps and tallow soaps, finish component, etc.

Sodium sulphide: (sulphuretted sodium). $Na_2S \cdot 9H_2O$; molecular weight 240. Fused mass or crystals (ratio 1 : 2), colorless (also weakly yellow), smell of hydrogen sulphide, hygroscopic, water soluble with alkaline reaction; gradually decomposes in the presence of air; reducing agent. Application: dissolving and dyeing with sulphur and vat-sulphur dyestuffs; de-hairing agent (tanning), etc.

Sodium sulphite: (sodium salt of sulphurous acid). $Na_2SO_3 \cdot 7H_2O$; molecular weight 252. White crystalline powder, ca 25% SO_2 , easily efflorescent (with oxidation to sodium sulphate), water soluble, weakly alkaline solution. Application: antichlor; reducing agent (printing); preservative; corrosion inhibitor in process water (binds acids), etc.

Sodium tetraphosphate: $Na_6P_4O_{13}$. Anhydrous sodium tetraphosphate contains ca. 60.4% P_2O_5 and 36% Na_2O , is hygroscopic and reacts weakly alkaline. In contrast tripolyphosphate will bind more calcium ions. Used as builder for paste/highly viscous synthetic detergents.

Sodium tripolyphosphate: (TPP, triphosphate, tripolyphosphate, sodium polyphosphate). $Na_5P_3O_{10}$; washing powder additive. Application: chelating agent for water softening; feed-water preparation; hot water supply systems; laundering; milling; after-rinsing, etc.

Sodium Thiosulphate: $Na_2S_2O_3$, a chemical used to neutralize chlorine in water for dye baths. The chlorine present in tap water can actually destroy small amounts of dye. This can be a problem, particularly when dyeing very pale shades where loss of a little dye can influence the final shade noticeably. Sodium thiosulfate is preferred for neutralizing chlorine for this application. Typical use would be about 0.15 grams per litre of bath. Sodium thiosulfate is the main ingredient in fixer (types sold as dry powder mixture) for black and white photographic processing. Most antichlor products for aquarium use are sodium thiosulfate.

Sodium tungstate: (sodium salt of wolframic acid), $Na_2WO_4 \cdot 2H_2O$; molecular weight 330; density 3.25. Colorless crystals, water soluble. Application: flame retardant and water repellent finishes.

Sodium Xylenesulphonate: $C_6H_3(CH_3)_2SO_3Na$. Highly effective hydrotropic agent for fat free soaps, scouring agents, washing powders and similar.

Sof: (1) A very fine, plain woven fabric, made by the natives of Kashmir of the finest sort of mohair; obsolete; (2) Very light, changeable or brocaded fine woollen from Asia Minor.

Soft dyeing technique: Term used for gentle handling of fabrics in the dyeing process with overflow or jet dyeing machines having controlled liquor flow.

Soft flow rope dyeing machines: Fabrics with a sensitive surface character that may be subject to creasing or surface roughening during the dyeing process are dyed on machines using the overflow principle in soft flow dyeing machines. Here the goods are not moved through a jet pipe but fall onto a smooth plate or are twice overflow-treated.

Soft Shell: Soft shell fabrics combine the benefits of hard shell fabrics with a breathable, flexible, comfortable fabric. Stretch wovens with a DWR treatment.

Soft silk: A silk from which the natural gum (sericin) has been completely removed by degumming.

Soft soap: See **Soap**.

Soft waste: See **Waste, soft**.

Soft water: Water with little or no *carbonate hardness* or *non-carbonate hardness*. It may originate in the hard rock areas or from peaty moorland, but not from chalk, nor from limestone formations. Soft water may be corrosive, as in *plumbosolvency*.

Soft window covering: Curtains, draperies, or other accessories on wall or window openings that are either lined or unlined and primarily constructed of textile fabrics.

Softener: A chemical or chemical mixture intended to give fabric a soft *hand*. Softeners act primarily as lubricants for fibres, allowing them to slide over each other more easily, giving a softer feel. Some also help reduce static electric charge build up, and some are antimicrobial. Many softeners are surfactants, and they may be cationic, anionic or non-ionic. Household laundry softeners are often based on cationic surfactants. Softeners can interfere with dyeing, so they should be removed by scouring. Some, such as silicones, can be quite difficult to remove.

Softener (Fabric): When the hand is made to drape more or to feel silkier, the fabric is said to have been softened. Chemicals that do this are called Softeners. Many softeners are derived from naturally occurring Fats, Oils and Waxes. Sources and reactions of fats, oils and waxes have been discussed in a Chapter 3. Some softeners are derived from synthetic raw materials. Many

of the compounds that work as softeners also function as surfactants or water repellents. These topics are covered in greater detail in other sections. It is hoped that the reader will come to appreciate that certain chemicals can serve many functions as textile finishes and processing auxiliaries. Softeners are divided into three major chemical categories describing the ionic nature of the molecule, namely Anionic, Cationic and Nonionic. Nearly all surfactants are softeners; however, not all softeners are surfactants. Surfactants are two-ended molecule, one end being lyophilic and the other hydrophilic. The lyophile is usually a long hydrocarbon chain, the essence of most lubricants. The ionic portion is responsible for water solubility, (a necessary feature for applying the softeners) and as will be discussed later, in how the molecule aligns itself at the fibre surface. This section will be devoted to describing the chemical structures of important softeners, some of their properties and their fabric uses. It is well to remember that the same chemical structure may describe a surfactant used for other purposes such as detergents, wetting agents, emulsifying agents etc.

Softener (water): Chemical(s) added to water to prevent hardness ions from interfering with other solutes Sodium hexametaphosphate (SHMP) is commonly used as a softener in dyeing. It will hold moderate amounts of hardness ions in solution. Soda ash will soften water, but it does it by formation of insoluble precipitates that can deposit on fabric or equipment, so SHMP is often added before soda ash to prevent this. Water softening systems which use common salt exchange hardness cations for sodium.

Softening point: The temperature at which substances without a sharp melting point change from viscous to plastic flow.

Softening range: The temperature range for synthetic fibres (according to each fibre type) that lies between becoming thermoplastic and the true melting point. It is not identical to the Transformation temperature but lies somewhat above.

Softness, in water: A relative absence of dissolved calcium, magnesium and other salts that react with soluble soaps to form insoluble precipitates.

Softness index: Calculated from the factors of surface smoothness or friction, yarn thickness and compressibility. Fabrics are tested as 1 cm. wide strips. Evaluation is based upon a 10 batch. The softness index indicates e.g. treatment with dist. water 1; with 0.5 gpl soap 1.10; after acidic bleach on cotton 1.36.

Sofu: Plain woven unbleached cotton sheeting in Japan, made usually 36 inches wide and 44/44.

Soie: French for silk.

Soie Mi-serree: French term for loose twist, glossy silk yarn for crochet.

Soie Mitorse: Half twisted silk yarn for embroidery. See **Mitorse silk**.

Soie Ondee: Silk yarn used for gauze; it is made by twisting a fine and coarse thread together.

Soie Ovale: French term for silk embroidery yarn.

Soie Platte: French floss silk yarn used for embroidery, tapestry, etc.

Soie Vegetale: Flax treated to have a high, permanent lustre. It bleaches and dyes well; used for braids, laces, etc. silk.

Soil affinity: The reduction in *Y* value between new and soiled fabrics.

Soil burial Test: A test of resistance of textile material to certain microorganisms present in soil. The samples are buried in soil for an extended period, then removed and measured for strength loss.

Soil Hiding: Ability of carpet to hide soil.

Soil redeposition: Redepositing of removed dirt from another fabric, onto the goods which is clean or relatively clean during washing or dry-cleaning processes. Anti-soil redeposition: Counteracts the re-deposition of dirt during washing.

Soil release: The property of dirt, especially oil based, being more easily released from textiles during cleansing processes. Synthetics and resin finished synthetic/cellulosic mixtures are poor in this respect in comparison to natural fibres.

Soil release Agent: Soil release products currently in use can be based on the following chemicals, for example: Silicium compounds, carboxymethylcellulose, ethoxylated compounds, polyglycol ester of terephthalic acid, acrylic acid polymers, and fluorochemicals.

Soil release Finish: Application of finishing processes that are specifically designed to ensure more efficient laundering of soil and stains. Good soil release effects are achieved through application of the Dual action principle, using fluorochemicals that are oleophobic and hydrophilic. See **Antisoiling finish**.

Soil repellency: Alternative term for Antisoiling finish Resistance to soiling as a finishing effect, which prevents soil penetration, or makes it difficult. Examples of soiling include dry soil (dust), wet soil (fruit juice, ink), oils and fats (engine oil and skin grease). Should not be confused with Soil release finish. Anti-soiling finishes.

Soil resist agent: Agents which are used in producing the Soil resistant finishes.

Soil resistant: Resistance against water-bound soil, fatty substances and pigment soiling.

Soiled end: Self explanatory.

Soiling: The staining or smudging of textile materials resulting from the deposit of dirt, oil undesirable dye, etc.

Soiling behaviour: Soiling behaviour of textiles is extremely dependent on the type of fibre, Soil release. No standardized tests exist for the soiling behaviour of carpets, because there are so many different types of soiling (dust, mud, lint of all types), and different colours and patterns. However, institutes use internal testing methods that permit absolute conclusions under specified conditions.

Soiling test: Wash or dry clean a test sample of a textile that has been artificially soiled, so that the level of optical brightening (Whiteness, degree of) achieved after washing or dry cleaning can be comparatively assessed. In principle, the soil test incorporates a combination of three soil types, such as carbon pigment, saponifiable fat, mineral oil (standard soil types).

Soil Resistance Merit Rating (SMR): Factor of soil resistance for carpets, taking into account the influence of colour. SMR indicates how high the soil concentration should be in a white test sample, so that the same apparent level of soiling as a specific colour can be achieved. The higher this value is, the greater the soil resistance of that colour. These values are defined on the basis of reflection measurements using a green filter (y value). Evaluation:

1.0–3.9 very bad

4.0–7.9 bad

8.0–15.9 fairly good

16.0–30.9 good

> 31.0 very good

E.g., white 1.0; mid-blue 33.0; coffee brown 190.0.

Soils: Soils can be defined as unwanted substances at the wrong place. Most common soils fall into one of four categories: (a) water borne stains, (b) oil borne stains, (c) dry particulate soils and (d) composite soils involving oil and grease adsorbed on particulate matter. Water borne stains are not much of a problem, the stains are soluble in the wash water. Food stains and dried blood, although not water soluble, are responsive to proteolytic enzymes found in most commercial detergents. Dry particulate soils such as flour, clay and carbon black are mechanically entrapped in the yarn interstices and reside on the surface of the fibre. Removal of particulate soils depends on overcoming the work of adhesion between the particle and the fibre surface, facilitating

the transport of detergent solution to where they reside and transporting the particle into the wash water. Mechanical energy (agitation) is important for latter.

Soisette: The name given to a fine cotton made from mercerized yarns. Its use is confined mainly to good quality nightwear and negligees, due to its softness.

So-Iron: A durable press rating. Fabric must have a smooth appearance after it is laundered dried (line dried or tumble dried). Fabric smoothness is referred to as Durable Press Rating (DP Rating) and is judged on a 1 to 5 scale. A 5 DP rating is the highest (most smooth) and a 1 is the most wrinkled. A 3.5 rating is considered commercially acceptable.

Soleil: The name of a very highly finished wool fabric woven in twill broken-rib effect. The weave and finish give the fabric a shiny appearance. The term is also used to describe any shiny, light reflecting fabrics in any fibres.

Solid braid, in rope: A braided construction in which each strand alternatively passes under and over one or more of the other strand while all strands are rotating around the axis with the same direction of rotation.

Solid Coloured: Fabric dyed in one colour.

Solid content: Dry substance content (in g) per kg of thickener, e.g. locust bean flour 20–25, locust bean flour derivatives 20–250, guar derivatives 40–250, starch ether 100–400, carboxymethyl cellulose 40–200, hydroxymethyl cellulose 15–40, crystal gum 250–330, carragheenes 50–100, polysaccharides 40–200, alginates 30–120, tragacanth 65–80, starch 80–100, polyvinyl products 100–200, polyacrylic products 200–250, British gum 500.

Solid-state polymerization: Reaction of the active end-groups within a solid polymer. It may be intentional as in heating and drying nylon 66 to increase the final degree of polymerization; or it may be undesirable such as that which occurs in fibres under high temperature conditions in tires that leads to increased degree of polymerization, cross-linking, and subsequent brittleness and loss of strength.

Solubilised sulphur Dyes: See **Solubilised vat dyes**. Sulphur dyes are insoluble pigments which are usually converted to soluble form with the addition of sodium sulphide and soda ash, which is the leucoform of the sulphur dye and is not stable. For the ease of application the sulphur dye can be converted to solubilised stable form by esterification of the leuco form and these are called solubilised sulphur dyes. These solubilised dyes are applied directly on the fabric and converted to original sulphur dye on the fibre fabric by suitable treatment.

Solubility: Symbol: *S* The amount of one substance that can dissolve in another to form a saturated solution under specified conditions of temperature and pressure. Solubilities are stated as moles of solute per kilogram of solvent (molality), or as kilograms of solute per cubic meter of solvent (density). The solubility of a solid in a liquid generally increases with temperature, whereas that of a gas in a liquid generally decreases. An increase in pressure on a gas above a liquid leads to a proportional increase in the solubility of the gas. See also **concentration**.

Solubilized vat dye: Also called Vat Leuco Ester Dyes. They are basically vat dyes which have been esterified by chemical reaction and thus made soluble for ease of application. The leuco compounds of a Vat or a Sulphur dyes are unstable unless special measures are taken.

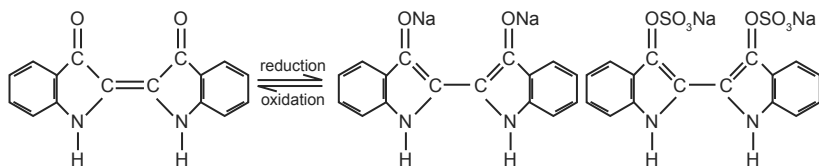

Indigo Dye Leuco form Anthrasol O, Solubilised dye by esterification

Dyeing with vat dyes is often accompanied by levelling problems since water-insoluble pigments are involved, which have to be made water-soluble by the addition of appropriate chemicals in order to dye the substrate. Vat leuco ester dyes, on the other hand, are already water-soluble products which produce very level dyeings. In most cases, these dyes have only slight substantivity and are used for dyeing and printing cotton as well as other cellulosic fibres. They are developed to the parent dyes using appropriate treatment after applying these on the fabric / fibre.

Solidonia: Proprietary name for a fibre of gloss and metallic whiteness and harsh feel, used for knit goods as substitute for silk or wool. It is made of a fibrous grass.

Solomon Bar: In macramé lace four threads braided together flat.

Solubility product: The equilibrium constant for a reaction involving a precipitate and its constituent ions is known as the solubility product.

Soluble: Capable of being dissolved, i.e., passing into solution.

Soluble chemical oxygen demand (SCOD): COD can be fractionated practically to particulate and soluble CODs. But there are little standardization on the definition of soluble versus particulate COD. Where filtration is the technique is used to fractionate the sample, the relative distribution between

soluble and particulate COD will vary greatly depending on the pore size of the filter. An alternative method used to determine the soluble COD involves precipitation of the suspended solids and a portion of the colloidal material. The COD of the clarified liquid corresponds to the soluble COD.

Solute: A material that is dissolved in solvent to form a solution.

Solution: A liquid system of two or more species that are intimately dispersed within each other at a molecular level. The system is therefore totally homogeneous. The major component is called the solvent (generally liquid in the pure state) and the minor component is called the solute (gas, liquid, or solid). The process occurs because of a direct intermolecular interaction of the solvent with the ions or molecules of the solute. This interaction is called Solvation. Part of the energy of this interaction appears as a change in temperature on dissolution. See also **heat of solution; solid solution; solubility**.

Solution-dyed: A type of fibre dyeing in which coloured pigments are injected into the spinning solution prior to the extrusion of the fibre through the spinneret. Fibres and yarns coloured in this manner are colour-fast to most destructive agents.

Solvent: A liquid capable of dissolving other materials (solids, liquids, or gases) to form a solution. The solvent is generally the major component of the solution. Solvents can be divided into classes, the most important being: *Polar*. A solvent in which the molecules possess a moderate to high dipole moment and in which polar and ionic compounds are easily soluble. Polar solvents are usually poor solvents for nonpolar compounds. For example, water is a good solvent for many ionic species, such as sodium chloride or potassium nitrate, and polar molecules, such as the sugars, but does not dissolve paraffin wax. *Nonpolar*. A solvent in which the molecules do not possess a permanent dipole moment and consequently will solvate nonpolar species in preference to polar species. For example, benzene and tetrachloromethane are good solvents for iodine and paraffin wax, but do not dissolve sodium chloride. *Amphiprotic*. A solvent that undergoes self-ionization and can act both as a proton donator and as an acceptor. Water is a good example and ionizes according to: $2\text{H}_2\text{O} = \text{H}_3\text{O}^+ + \text{OH}^-$ *Aprotic*. A solvent that can neither accept nor yield protons. An aprotic solvent is therefore the opposite to an amphiprotic solvent.

Solvent bleaching: Oxidation bleach with sodium chlorite in organic solvents. Peroxide bleaching of wool using tetrachloroethylene liquors was an example of an exhaustion process in Solvent technology in textile finishing. Aqueous emulsions of H_2O_2 in tetrachloroethylene have 100% attraction to hydrophobic wool, which they bleach during the drying phase, continuing for 24 hours until bleaching is complete.

Solvent bonding: A method of making nonwoven fabrics in which a solvent is used to soften the fibre surfaces in a web or batt and hence cause bonding.

Solvent dye: See **Solvent dyeing**. These water-insoluble but solvent-soluble dyes are devoid of polar solubilizing groups such as sulfonic acid, carboxylic acid, or quaternary ammonium. They are used for colouring plastics, gasoline, oils, and waxes. The dyes are predominantly azo and anthraquinone, but phthalocyanine and triarylmethane dyes are also used.

Solvent dyeing: (organic solvents). A process developed in the 1970s, which was designed to replace water as a dyeing medium with suitable solvents, because water was becoming more and more expensive and scarce. Solvent dyeing is only used in specialist dyeing areas as a complementary process for existing aqueous dyeing processes.

Solvent dyeing process: There are two different types of dyeing process: (a) Ionic dyeing process for polyamide and wool: water soluble acidic dyes and special tetrachloroethylene-soluble acidic dyes are used for both fibre types. Since hardly any dyeing occurs without the addition of a "solvent aid", it is essential to add water, because otherwise no ionic bond will be able to form between the dye and the fibre. (b) Non-ionic dyeing process for polyester: in this process, the coloristic advantages and the process advantages stand out particularly in comparison with the aqueous process. Tetrachloroethylene, ethylene glycol, diethylene glycol and glycerine are all examples of a possible solvent medium.

Solvent extraction: (liquid-liquid extraction). A method of removing a substance from solution by shaking it with and dissolving it in a better solvent that is immiscible with the original solvent.

Solvent impregnation: (solvent waterproofing). Specialist technique for waterproofing in organic solvents (benzine, heavy benzine, tetrachloroethylene, etc.) with Solvent impregnation agents. Important in dry-cleaning for re-impregnating garments after cleaning.

Solvent relative humidity: The humidity of air over a drycleaning bath and in equilibrium with the solvent and a small amount of water.

Solvent scouring: Washing off scrooping or solvent preparations (solvent finishing). In the treatment of polyester, it should be remembered that this type of fibre is capable of solvent sorption, which accelerates dye diffusion.

Solvent sizing: Sizing of warp ends (widthwise) using organic solvents. It is carried out in a completely sealed pressure system in a suitably constructed solvent sizing machine. Polystyrene, for instance, is applied cold, can

subsequently be removed from the fabric by means of tetrachloroethylene (desizing; extraction possible using ultrafiltration), and long-term experiments in the weaving industry have shown that this method is well suited to sizing.

Solvent spinning: See **Spinning, Dry-spinning**.

Sommier: All-wool, French serge, made very soft and napped on one or both sides; used for lining of winter garments. Comes in bleached, ecru or dyed in the piece.

Sorbitol: Hexahydric alcohol. Manufactured by reducing d-glucose or dextrose derived from starch or maize. There are different forms: a) white powder or colorless needle-shaped crystals, melting point 100–120°C, easily soluble in water, pyridine, methanol, acetic acid, phenol, not so easily in cold alcohol; b) syrupy solution with 70–80% sorbitol content, density greater than 1.26, neutral, non-reducing, odourless, non-toxic, sweet taste. Application: alternative to glycerine for sizing, finishing, dyeing, printing; for plasticizing rubber and glue; for softening the gelatinous layers on print rollers.

Sorption: The process of taking up or holding a material by adsorption or absorption or both.

Soumak Rugs: All-wool tapestry ruga woven in Transcaucasia. They come in all sizes. The design is geometrical. The hook is often used, the stitches being made in the herringbone fashion. It is also called Kashmir. Modern Soumarks are made in loose weave and with coarse dye.

Souple: Single filament of natural silk with the gum only partly boiled out (also called Mi-cuit).

Sourbassis: White or yellowish Persian raw silk of fine quality.

Source: To find suppliers of the required materials.

Souring: Any treatment of textile materials in dilute acid. Its purpose is the neutralization of any alkali that is present.

Soutache: Narrow rounded braid woven in herringbone effect with odd number of threads made either plain or fancy; used for trimming.

Space dyeing: Sectional printing or dyeing of yarn and cable in varying stages of processing, various colour shades, as well as in different intervals and lengths. In space dyeing it is scarcely possible to differentiate between dyeing and printing. The space dyeing process provides an opportunity to create interesting types of pattern. Multi-coloured, irregular motifs and imaginative effects on the fabric can be achieved by using yarn with partially bordered patches of colour. The washed out looking, asymmetrical patterns on upholstery covers and domestic textiles (floor coverings) are particularly dominant.

Spacer: Spacers are for supporting and sealing the yarn layers in yarn package dyeing.

Spacer Fabric: Spacer fabrics can be described as three-dimensional orthogonal structures with yarns in the x , y and z directions (Fig. below). Numerous definitions of a spacer fabric exist. Roye and Gries (2007) describe such materials as comprising a three dimensional yarn architecture and a three-dimensional textile architecture, produced by the weaving process (woven spacer fabrics), by circular knitting machines (weft-knitted spacer fabrics), or by double needle bar warp knitting processes (warp-knitted spacer fabrics). Two separate fabrics faces knitted independently and then connected by a separate spacer yarn.

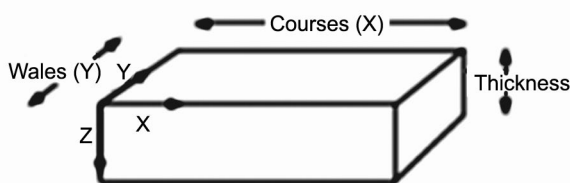

Schematic Diagram of Spacer fabric

These fabrics can be produced on both circular and flat knitting machines. Spacer fabrics have the properties of good breathability, crush resistance, and a 3D appearance.

Span length, in length testing of cotton with Fibrograph: The distance spanned by a specified percentage of the fibres in the test beard, taking the amount reading at the starting point of the scanning as 100%.

Spandex: A synthetic elastic fibre of polyurethane lycra (Invista, formerly Dupont) is a well-known brand of spandex. Spandex is found in fabrics either as bare fine filaments or covered with another fibre. Spandex can be dyed with disperse dyes and some acid dyes.

Usually where bare filaments are used, they are quite inconspicuous even if they are not dyed to match the fabric. Spandex will withstand most preparation and dyeing processes without damage, but is damaged by chlorine bleach.

Spandex fibre: A manufactured fibre in which the fibre forming substance is long chain synthetic polymer comprised of at least 85 % of a segmented polyurethane.

Spanish lace: The most common Spanish lace is made of silk in flat designs, usually floral, and held together with a mesh, but the term Spanish lace also refers to all lace made in Spain.

Spanish Stitch: In embroidery cross stitches arranged in a row to form a line on the face of the fabric and squares on the back.

Spanish Stripes: A lightweight, wide and fulled woollen cloth, originally made of Spanish wool with striped selvage, now made mostly in England. It is light, very soft and well finished with a light nap.

Spatterdash: A sort of overgaiter or legging.

Sparta carpets: Isparta carpets.

Sparterie: Stiff fabric, used in making hat bases as it can easily be shaped.

Spau press: Cold Flat press.

Specialty felt: One of a number of special purpose felt structure available for, but not limited to, specific use or application.

Specific area, of wool: The ratio of the fibre surface to fibre volume.

Specific gravity: Ratio of the mass of a material to the mass of an equal volume of water at 4°C. The range for modern fibres is not too great and is dependent to some extent on the liquid used as an immersant in measurements, because of fibre swelling and of possible absorption of liquid into fibre voids. (Also see **Density**.)

Specific gravity, of felt: The relative mass per unit volume of felt expressed as a percentage of mass per unit volume of water.

Specification: A precise statement of a set of requirements to be satisfied by a material, product, system, or service that indicates the procedures for determining whether each of the requirements is satisfied.

Specimen: A specific portion of a material or a laboratory sample upon which a test is performed or which is selected for that purpose.

Speck: (1) A contaminant in polymer such as gels, metal, or dirt that shows up as a dark spot. (2) A small particle of foreign substance that has not been removed from the stock before spinning.

Speck printing: The Specks that are usually not required in printing are produced artificially by using encapsulated dyes, so that the resulting print profile consists of dots of equal sizes in a mono or multi colour way. This print effect can be carried out on various different types of fibre if suitable dyes are used, for example in transfer printing on polyester.

Speckiness: See **Specky fabric**.

Specking: The removal of burrs, knots, and other objects that impair the finished appearance of woollens and worsteds.

Speckle: Uneven dyeing in yarns or cloths.

Specks, in woollen fabric: Small pieces of undyed vegetable matter which can be removed by carbonizing or can be covered by dyeing or inking.

Specky: A term used to describe dyed woollen fabric with specks of undyed vegetable matter on the face. The specks can be removed by carbonizing or covered by speck dyeing.

Specky cloth: See **Specky fabric**.

Specky fabric: Dyed fabric which shows small specks of undyed vegetable matter in the face.

Spectrophotometer: Photometric device that measures spectral transmittance, spectral reflectance or relative spectral emittance.

Spectral Curve: A colour's "fingerprint"—a visual representation of a colour's spectral data. A spectral curve is plotted on a grid comprised of a vertical axis—the level of reflectance intensity; and a horizontal axis—the visible spectrum of wavelengths. The percentage of reflected light is plotted at each interval, resulting in points that form a curve.

Spectrophotometric curve: A curve measured on a spectrophotometer; a graph with relative reflectance or transmittance (or absorption) as the ordinate, plotted with wavelength or frequency as the abscissa.

Spectroscopy: The study of methods of producing and analyzing spectra using spectroscopes, spectrometers, spectrographs, and spectrophotometers.

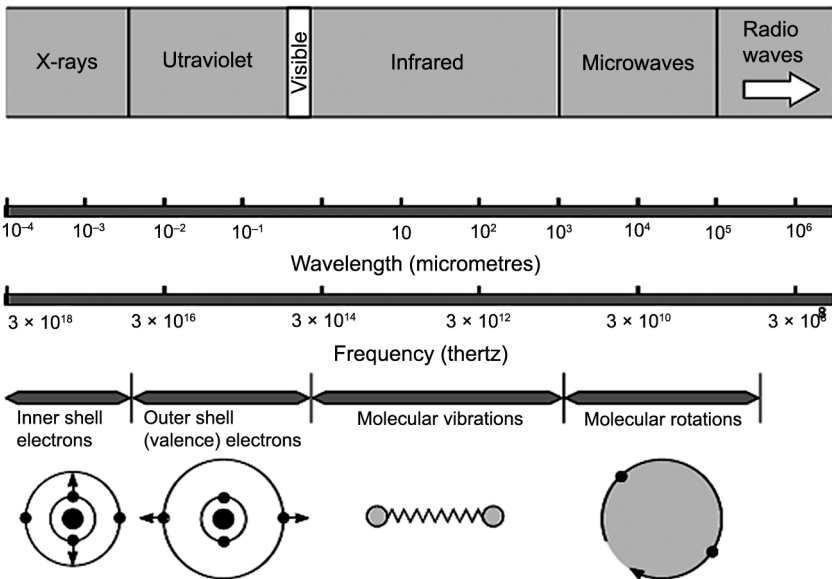

The interpretations of the spectra so produced can be used for chemical analysis, examining atomic and molecular energy levels and molecular structures, and for determining the composition and motions of celestial bodies.

Spectral Data: The most precise description of the colour of an object. An object's colour appearance results from light being changed by an object and reflected to a viewer. Spectral data is a description of how the reflected light was changed. The percentage of reflected light is measured at several intervals across its spectrum of wavelengths. This information can be visually represented as a spectral curve.

Spectral power distribution curve: Intensity of radiant energy as a function of wavelength, generally given in relative power terms.

Spectral energy distribution: The variation of energy due to the source over the wavelength span of the emitted radiation.

Spectral Power Distribution (SPD): The spectral power distribution (SPD) of a light source provides the required numerical description of it. The SPD gives the emitted power (watts per square metre of emitter surface per unit wavelength interval, $W m^2 nm^{-1}$) as a function of the wavelength.

Spectral transmittance: The percent of incident radiant energy passing through a given material and not absorbed in the process, as a function of wavelength.

Spectral distribution of energy: See **Spectral energy distribution**.

Spectrograph: A spectroscope equipped with a camera or some other device for recording the spectrum. Also see **Spectroscope**.

Spectrometer: (1) An instrument for examining the different wavelengths present in electromagnetic radiation. Typically, spectrometers have a source of radiation, which is collimated by a system of lenses and/or slits. The radiation is dispersed by a prism or grating, and recorded photographically or by a photocell. There are many types for producing and investigating spectra over the whole range of the electromagnetic spectrum. Often spectrometers are called *spectroscopes*. See also **spectrophotometer**.

(2) Any of various other instruments for analyzing the energies, masses, etc., of particles. *See* mass spectrometer.

Spectrophotometer: An instrument used to measure the transmission or reflectance of light as a function of wavelength. A form of spectrometer able to measure the intensity of radiation at different wavelengths in a spectrum, usually in the visible, infrared, or ultraviolet regions.

Spectroscope: An instrument for forming a spectrum for visual examination.

Spectroscopy: The identification of materials by the analysis of their spectra.

Spectrum: Spatial arrangement of components of radiant energy in order of their wavelengths, wave number or frequency.

Specular gloss: The relative luminous fractional reflectance of a specimen in the specular direction. Relative luminous fractional reflectance from a surface in the mirror or specular direction. It is sometimes measured at 60° relative to a perfect mirror.

Reflectance factor: The ratio of the light reflected from the specimen to the light reflected from the perfect reflecting diffuser under the same geometric and spectral conditions of measurement.

Specular reflectance: Reflectance of a beam of radiant energy at an angle equal but opposite to the incident angle; the mirror-like reflectance. The magnitude of the specular reflectance on glossy materials depends on the angle and the difference in refractive indices between two media at a surface. The magnitude may be calculated from Fresnel's Law.

Specular reflectance excluded (SCE): Measurement of reflectance made in such a way that the specular reflectance is excluded from the measurement; diffuse reflectance. The exclusion may be accomplished by using 0° (perpendicular) incidence on the samples. This then reflects the specular component of the reflectance back into the instrument by use of black absorbers or light traps at the specular angle when the incident angle is not perpendicular, or in directional measurements by measuring at an angle different from the specular angle.

Specular reflectance included (SCI): Measurement of the total reflectance from a surface, including the diffuse and specular reflectances.

Specular reflection: The reflection without diffusion, in accordance with the laws of optical reflection, as in a mirror.

SPF (Sun Protection Factor): SPF measures the effectiveness of sunscreen on the body. The test for SPF is done by using a living organism or body to measure the length of time it takes for the skin to redden without coverage or protection.

Spencer: Short, narrow-waisted jacket with lapels; sleeveless or short sleeved.

Spherulite: A common form of polymer crystallization from melts or concentrated solutions. These crystallites show a radial symmetry from a central point and have a distinctive maltese cross pattern of birefringence under the polarizing microscope.

Spider Leno: See **Net leno**.

Spider silk: Product of silk spider (Madagascar). Without silk glue. Extremely light. Strength, glaze and elasticity similar to genuine silk but finer. Spiders silk also known as gossamer is a protein fibre spun by spiders. Spiders use their silk to make webs. Many small spiders use silk threads for ballooning, the scientific term for dynamic kiting spider lings (mostly) used for dispersal. They extrude several threads into the air and let themselves get carried away with upwards wind.

Spider Weave: Name for weaves producing a net-like effect on the face of the cloth by floating and deflecting either the warp or the weft threads.

Spider Wheel: See **Catherine wheel**.

Spiking: Use of spikes fixed to one edge of a hinged table to facilitate the even laying up of fine material. The table top is tilted vertically for hanging the material and back to the horizontal for cutting.

Spin finish: “Oiling agents” consisting of oils or fats and surfactants the behaviour of which, depending on the task in hand and composition, comes somewhere between textile lubricants and textile softening agents. See **Lubricant**.

Spin multiplier: See **Twist Multiplier**.

Spin stretch Ratio: In man-made filament extrusion, the ratio of taken-up or haul off speed to the average speed of the spinning fluid as it leaves the spinneret.

Spin drawing: (1) The reduction of roving during spinning by a roller drafting mechanism similar to that used on the roving frame. (2) Combined spinning and drawing in one operation in melt-spun fibres.

Spindle: (1) Device on spinning and twisting machines for holding packages and the like for imparting a twist to or roll-batching yarn on a spinning frame, roving frame, twister, winder, or similar machine. A bobbin is placed on the spindle to receive the yarn as the spindle is rotated at high speed. (2) Hydrometer. (3) Threaded shaft for the transmission of turning motion.

Spindle tape: A woven narrow fabric of width normally not greater than 50 mm. usually of high warp density and designed for the transmission of power spindle wharves of small diameter.

Spinneret: A metal disc containing numerous minute holes used in manufactured fibre extrusion. The spinning solution or melted polymer is forced through the holes to form the fibre filaments.

Spinnerette: Same as **Spinneret**.

Spinning: The process or processes used in the production of yarns or filaments. (a) This term may apply to the drafting and twisting of natural or man-made fibres (see continuous spinning, intermittent spinning, open-end spinning), to the extrusion of filaments by spiders and silkworms, or to the production of filaments from glass, metals or fibre-forming polymers.

(b) In the spinning of man-made filaments, fibre-forming substances in the plastic or molten state, or in solution, are forced through the holes of a spinning jet (q.v.) or die at a controlled rate (extrusion). There are five general methods of spinning man-made filaments, but a combination of two (or more) of these methods may also be used. They are the following:

- (i) *Dispersion Spinning:* The process in which polymers that tend to be infusible, insoluble and generally interactable (e.g. polytetrafluoroethylene) are dispersed as fine particles in a carrier, such a sodium aliginate or sodium xanthate solutions, which permits extrusion into fibres, after which the dispersed polymer is coalesced by a heating process; the carrier is removed either by a heating or by a dissolving process.
- (ii) *Dry Spinning:* The process in which a solution of the polymer is extruded into a heated chamber to remove the solvent and leave the solid filament.
- (iii) *Melt Spinning:* The process as used in the manufacture of nylon in which the fibre-forming polymer is melted and extruded into air or other gas or a suitable liquid, where it is cooled and solidified.
- (iv) *Reaction Spinning:* The process in which polymerisation is achieved during the extrusion through spinning jet (q.v.) system of reactants.
- (v) *Wet Spinning:* The process as used in the manufacture of viscose rayon in which the solution of the polymer is extruded into coagulating media where the polymer is regenerated.

(c) In the bast fibre and leaf fibre industries, the terms “dry spinning” and “wet spinning” refer to the spinning of fibres in the dry state and in the wet state, respectively.

Spinning, general: (1) The process or processes used in the production of single yarns:

Yarn from staple fibre: The formation of yarn from sliver or roving by drafting and twisting. *Filament yarn or tow:* The formation of filaments by extrusion of fibre forming substance either in molten form, in solution or in a form suitable for regeneration.

Yarn from filament tow: The formation of yarn from tow by cutting or breaking drafting and twisting in a single operation often called direct spinning.

(2) Spinning: The process or processes used in the production of single yarns or of fabrics generated directly from polymer:

Yarn from Staple Fibre: The formation of a yarn by a combination of drawing or drafting and twisting prepared strands of fibres, such as rovings.

Filament Yarn: In the spinning of manufactured filaments, fibre-forming substances in the plastic or molten state, or in solution, are forced through the fine orifices in a metallic plate called a spinneret, or jet, at a controlled rate. The solidified filaments are drawn-off by rotating rolls, or godets, and wound onto bobbins or pirns. There are several methods of spinning manufactured filaments:

Dry Spinning: The process in which a solution of the fibre-forming substance is extruded in a continuous stream into a heated chamber to remove the solvent, leaving the solid filament, as in the manufacture of acetate.

Gel Spinning: A spinning process in which the primary mechanism of solidification is the gelling of the polymer solution by cooling to form a gel filament consisting of precipitated polymer and solvent. Solvent removal is accomplished following solidification by washing in a liquid bath. The resultant fibres can be drawn to give a product with high tensile strength and modulus.

Melt Spinning: The process in which the fibre-forming substance is melted and extruded into air or other gas, or into a suitable liquid, where it is cooled and solidified, as in the manufacture of polyester or nylon.

Phase-Separation Spinning: Extrusion of polymer and solvent at high temperature into a cooling zone. During the cooling process, a phase separation occurs, usually accompanied by crystallization of the solvent. Solvent can be removed before or after drawing.

Reaction spinning: Process in which an initial prepolymer is formed and then extruded into a reagent bath where polymerization and filament formation occur simultaneously. Spandex fibres can be made by this process.

Wet Spinning: The process in which a solution of the fibre-forming substance is extruded into a liquid coagulating medium where the polymer is regenerated, as in the manufacture of viscose or cuprammonium rayon.

Yarn from Leaf and Bast Fibre: In the manufacture of leaf and bast fibre yarns, the terms “wet spinning” and “dry spinning” refer to the spinning of fibres in the wet state and in the air-dry state, respectively.

Yarn from Filament Tow: The formation of a yarn from filament tow by a combination of cutting or breaking, drafting, and twisting in a single series of operations. Also known as converting.

Nonwoven Fabric: Fabrics can be produced directly from molten or dissolved fibre-forming substances by several continuous processes:

Flash Extrusion: The process in which a fibre-forming substance in a volatile solvent is extruded from a high-temperature, high-pressure environment into lower temperature and pressure conditions, causing the solvent to rapidly evaporate, leaving a lacy, net-like fabric.

Spinning, direct: The manufacture of yarn from sliver on the cotton system, bypassing the roving process.

Spinning, dry: Conversion of a dissolved polymer into filaments by extrusion and evaporation of the solvent from the extrudate. Solvent is removed through flows of warm gas suitably directed to the extruded filaments; gas temperature should be higher than the boiling temperature of the solvent, which will be extracted from the filaments, recovered and recycled.

Spinning, flash: A modification of the accepted dry spinning method in which a solution of a polymer is extruded at a temperature well above the boiling point of the solvent such that on emerging from the spinneret evaporation occurs so rapidly that the individual filaments are disrupted into a highly fibrillar form.

Spinning cake: (spindle crown), a yarn package which has been spun according to the centrifugal or so-called can or pot spinning method (rotating pot resulting in the shape of a ring-shaped cake with the characteristic hole in the centre. These slightly conical spinning cakes occur in different sizes but they are always in the form of compact blocks of yarn tightly wound in almost parallel layers.

Spinning frame: A machine used for spinning staple yarn consisting of a number of spinning positions for converting slivers, slubbings or rovings into yarns. It drafts the roving to the desired size, inserts twist, and winds the yarn onto a bobbin. The term is generally used to indicate a ring spinning frame, although it does cover flyer spinning and cap spinning on the worsted system.

Spinning limit: The finest yarn number that can be spun satisfactorily from a specified lot of fibre under specified conditions.

Spinning performance: A method for the evaluation of end breakage rate during spinning which is commonly expressed in units of ends down per 1000 spindle-hours, but may be based on other units such as 'spinnable limit' or ends down per specified time other than 1000 spindles-hours, yardage, or condition.

Spinning solution: A solution of a fibre-forming polymer (e.g., cellulose acetate) in a suitable condition to be extruded by either dry spinning or wet spinning.

Spinning test: The processing of a specific lot of stock into yarn for evaluation of processing performance and product quality at various stages of processing or both.

Spinning twist: The twist added to yarn during spinning to give it strength and other desired characteristics.

Spinning, dry: See **Spinning**.

Spinning, open end: See **Open end Spinning**.

Spinning, break: See **Spinning, open end**.

Spinning, cap: A spinning system in which the lower edge of a stationary cap is supported by the spindle, the lower edge of which guides the yarn on to the revolving spinning package which is traversed.

Spinning, collapsed balloon: A system of ring spinning in which the rotating yarn balloon is eliminated by contact with the top of the spindle. Note (a): The system is normally used for economic spinning of semi-worsted and woollen carpet yarns by permitting the use of larger package sizes and/or higher spindle speeds. Note (b): Special spindle top extensions are used to obtain the desired effects.

Spinning, direct: See **Spinning**.

Spinning, double roving: A system in which two rovings are fed to each spindle of a ring frame so producing a pseudo two-fold or two-strand yarn. The rovings are separated in the drafting system by means of special guides and the two drafted strands are combined after the drafting system.

Spinning, flyer: A spinning system in which yarn passes through a revolving flyer leg guide on to the package rotating at slightly different speeds.

Spinning, friction: A method of open-end spinning which uses the external surface of two rotating rollers to collect and twist individual fibres into a yarn. At least one of the rollers is perforated so that air can be drawn through it surface to facilitate the fibre collection. The twisting occurs near the nip of the rollers and because of the relatively large difference between the yarn and roller diameters, high yarn rotational speeds are achieved by the friction between the roller surface and the yarns.

Spinning, hollow spindle: A system of yarn formation in which the feed stock (sliver or roving) is drafted and the drafted twistless strand is wrapped with a yarn as it passes through a rotating hollow spindle. The binder or wrapping yarn is mounted on the hollow spindle and is unwound and wrapped around the core because of the rotation of the spindle. This technique may be used for

producing a range of wrap yarns, fancy yarns by using different yarn and fibre feed stock fed to the hollow spindle, at different speeds.

Spinning, jet: (Also called Airjet spinning). A system of staple fibre spinning which utilizes air to apply the twisting couple to the yarn during its formation. The air is blown through small holes arranged longitudinally to the yarn surface and this causes the yarn to rotate. The majority of systems using this technique produce faciated yarns but by using two air jets operating in opposing twist direction it is possible to produce yarn with more controlled properties but of more complex structure.

Spinning, ring: A spinning system in which the twist is inserted in a yarn by revolving traveller.

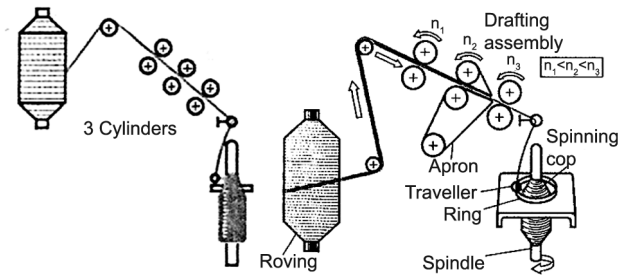

Ring Spinning (Schematic)

Principle of ring spinning

The yarn is wound on by the package rotating faster than the traveller.

Spinning, rotor: A method of open-end spinning which uses a rotor (high speed centrifuge) to collect and twist individual fibres into a yarn. The fibres on entering the rapidly rotating rotor as distributed around its circumference and temporarily held there due to the centrifuging force. The yarn is withdrawn from the rotor wall and because of the rotation of the rotor, twist is inserted.

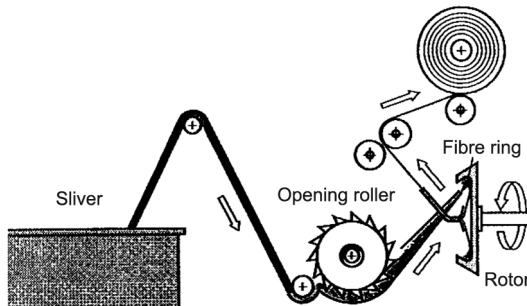

Principle of rotor spinning

Spinning, self twist: A method of making a yarn from rovings fed to a drafting unit; the emerging strand of fibres is subjected to a cyclically reversing false twisting action which can be imparted in a number of ways. Two adjacent strands delivered from the false twist system are brought together by guides, and the torque in the two strands causes them to wrap about each other. This wrapping action is defined as 'self twist' and produces a self twist pattern of -S-Zero-S-Zero- etc. in the yarn produced. The self twist yarn is then taken up as a cheese.

Spinning, Semi collapsed balloon: A system of ring spinning in which the rotating yarn balloon is eliminated at the start of an empty bobbin and is allowed to expand later when the bobbin is becoming filled with the yarn. The small balloon condition is achieved by allowing contact between the rotary balloon and the spindle top. As the contact is broken and the yarn balloon is allowed to reform. Notes (a) The system is often used for worsted and semi worsted spinning. (b) Special spindle top extension are used to obtain the required effect.

Spinning, Suppressed balloon: See **Collapsed balloon spinning**.

Spinning, Twistless: A system of yarn formation which relies on the use of a permanent or temporary adhesive to bond the fibres together. Note: Where a temporary adhesive is used it is removed during fabric finishing and the yarn (and fabric) strength is obtained through lateral pressure on the yarn produced by the yarn interlacings in the fabric. A similar fabric construction can be achieved by using warp spun yarns which have been produced with a soluble binder.

Spinning, warp: See **Spinning**.

Spinning, wet: It is the process in which a solution of the polymer is extruded into a liquid when the polymer is regenerated as in the manufacture of viscose or cuprammonium rayon.

Spiral yarn: Specialty yarn made by winding heavier, slackly twisted yarn around a finer yarn with a hard twist to give a slubby appearance.

Splash voile: See **Voile**.

Splice: (1) The joining of two ends of yarn or cordage by intertwining or interweaving strands. (2) The joining of two ends of yarn or cords by means of several knots joining individual yarns or strands the knots being staggered that is, located at some distance from each other along the yarn or the cord. (3) The joining of two ends of a material whereby ends are tapered, lapped and subsequently seized, bound, stitched or stapled.

Splice defective: A splice having irregular final twist, untrimmed ends or excessive thickness or thinness.

Spliced: Reinforced parts of hosiery where the wear is the greatest.

Splicer: Controllable ancillary device on automatic bobbin winders which carry out the splicing operation at the winding head when there is a thread break.

Splicing: (1) The joining of two ends of yarn or cordage. There are several methods used, e.g., by interweaving the strands, by the use of knots, by tapering, lapping, and cementing the ends, etc. Splicing technology is regarded as a genuine alternative to knot-free joining technology. (2) A method of reinforcing knits, e.g., the heels and toes of hosiery, by introducing an additional yarn for strength.

Splinter: Two or more staple fibres adhering together, causing a stiff cluster that resists pulling apart in normal processing, and reacting in the yarn spinning process similarly to higher than nominal denier fibre.

Splinter count: A measure of the number of coalesced fibres, mealy particles, or other such matter in staple fibre.

Split: Two or more lengths of fabric that are woven side by side and subsequently separated from each other by cutting along lines formed by leaving one or more dents. Fraying at the cut edges may be prevented by the use of a leno edge (q.v.) or other suitable means.

Split end: See **Broken filament**. (1) A defect in fabric caused by breakage of some of the singles yarns in a plied warp yarn. (2) A defect in manufactured filament yarn caused by breakage of some of the filaments.

Split stitch: A flat chain stitch used in old church embroidery. Bring the thread through at A and make a small stitch over the design, piercing the working thread with the needle. Split Stitch may be used as a filling where a fine flat surface is required.

Split weft(strained weft): A continuous-filament thread that has lost some of its filaments, usually as a result of abrasion or excessive tension during winding or weft insertion and that appears as a thin yarn.

Split Filaments: See **Broken filaments**.

Split Harness: A knot in each double-harness cord below the comber board and above the mail to form a loop long enough to allow a proper depth of shed. A rod is passed through the loops of each long row of harness cords so that each is capable of lifting all the ends in one row of cords independently of the figuring cards. The jacquard lifts the required ends to form the ground weave. The harness is used in weaving jacquards with a finely sett warp and move open weft.

Split-Draft Metier: An extrusion cabinet for dry spinning in which the drying medium (hot air) is introduced between the jet and the yarn outlet and flows in both directions.

Split-Flow Metier: See **Split-draft Metier**.

Split-Stitch, in knitted fabrics: A stitch in which one part of the yarn is knit and the other part is dropped.

Splitting: (1) In the processing of tow, a defect in which the integrity of opened tow is disturbed by separation or division into two or more segments longitudinally. Splitting can be continuous or intermittent, long or short term. (2) In slashing, the separation of sized yarn ends before takeup on the slasher beam.

Splitting resistance, in felt: The force required to overcome the interfacial strength of a material and specifically to separate a felt into two layers (of approximately equal thickness).

Sponge: (1) Name for a crepe weave made with equal number of warp and weft floats; (2) A honeycomb weave, made with small diamonds on a satin ground, resulting in very small cells.

Sponge Cloth: (1) coarse fabric, made of cotton waste and used for cleaning machinery; (2) fine dress fabric of cotton, wool or silk, made of nub yarn in twill weave.

Sponging: A pre-shrinkage process which involves the dampening with a sponge to woollen and worsted fabrics. The process is accomplished by rolling in moist muslin, or by steaming. This procedure is performed at the fabric mill prior to cutting to insure against a contraction of the material in the garment.

Spool: A flanged wooden or metal cylinder upon which yarn, thread, or wire is wound. The spool has an axial hole for a pin or spindle used in winding. (Also see **BEAM**.)

Spool (Axminster and gripper spool): A double flanged bobbin on which a number of threads of pile yarn are wound in a predetermined order for use in Spool Axminster and Gripper spool loom. The yarns from a spool for all or a part of a row in the carpet design.

Spool rack: Spool rack is a frame with thin horizontal metal rods that can support many spools of thread. Multiple ends can be unwound at the same time from the rotating spools to fill a section of a sectional warp beam or to pass through the slots and holes of a warping paddle.

Spoon bonnet: Small bonnet tied under the chin with a ribbon.

Spot: A small discolored area on, or in, a fabric.

Spot and stain removal: see **Spotting**. A cleaning procedure for localized areas using cleaning agents and mechanical action specific to the removal of the foreign substances present.

Spot bonding: See **Bonding, Point bonding**.

Spot clean: To remove localized spots and stains by treating them with cleaning agents and mechanical actions specific to the fabric, fibre and the product type and the foreign material present.

Spot weave: Spot designs are formed by extra warp or filling yarns. The yarns are inserted the entire length or width of the fabric, spots or dot designs are formed. The long floats on the back side are cut away, leaving the dots. The threads can be pulled easily. Filling threads are easy to cut but warp floats are difficult. Example: **Dotted swiss**.

Sport shirt, for boys: A shirt made in numerical sizes, designed for informal wear and may be worn with or without a jacket.

Sport shirt, for men: A shirt designed for informal wear and made with body sizes such as small, medium, or large, and may be worn with or without a jacket.

Sports jacket: Fashionable men's jacket with sack-shape cut; without shape, used as a summer jacket; shaped, used as a sports jacket (also high-quality, elegant designs, 250–500 g fabric weight) with shape retaining interlining also used as a holiday jacket (See **Topper**).

Sports clothing: Functional clothing for special requirements (Active wear); not to be confused with Sportswear.

Sportswear: Leisure sports and town and weekend clothing in the form of Casual wear in a functional but smart genre, with sports-like attractive details; includes knitted wear and imitation leather.

Spotclean: See **Spotting**.

Spotting: (1) A cleaning procedure for localized areas with cleaning agents and mechanical action specific to the removal of the foreign substances present.

(2) In England same as crabbing.

Spotting agent: Used for removing local contamination (spots, etc.) on textile goods.

Spotting powder: Used to absorb moisture during spotting in order to prevent the appearance of the feared stain borders. Active components: talcum, kaolin, fullers earth and gypsum.

Spray bonding: A process of binding fibres into a nonwoven fabric involving the spray application of a fabric binder to the fibre web or batt. See **Bonding**.

Spray-dampening: Finishing character work; particular usual for washing cloths and wool cloths and the like in order to impart the desired moisture content and heavy, soft handle to the fabric. In most cases with nonsupersaturated moist air after the drying frame (stenter drying) on the spraying machine by spray jets or rotating brush rollers according to the so-called “natural moisture” principle.

Spray dyeing machine: A form of Hank dyeing machine for dyeing hank yarn on perforated yarn-carrier tubes with firmly connected rotating hanks. The machine gently turns suspended hanks. The liquor is sprayed on the hanks through the perforations.

Spray finishing: Finishing with Spray dyeing machine, used particularly for pressure-sensitive silk, viscose filaments and blended fabric articles such as crêpe de chine, marocain crêpe, flamisol crêpe, georgette crêpe, bark crêpe, moss crêpe, blister crêpe, matelassé, hammer blow and even for taffeta and similar smooth articles as well as for dress fabrics and linen fabrics for correcting the final handle.

Spray finishing machine: Special machines derived from older spray dampening machines which apply finishing liquors in the form of powders or low viscosity mists through nozzles either on one or both sides as a form of pray finishing.

Spray printing: The pattern is produced by Stencils for spray printing. The thin and finely matched printing ink solutions are sprayed through the fine stencil voids on to the goods using nozzle atomizers or compressed-air spray guns (air extraction and safety spectacles required).

Spray spinning: Application of a fabric binder.

Spread stitches: See **Pin hole**.

Sprig: Patterns of flowers and leaves in hand -made laces, made separately and applied on a net ground.

Spring needle: A knitting machine needle with a long, flexible hook, or beard, that allows the hook to be closed by an action known as pressing so that the loops can be cast off. The hook springs back to its original position when the presser bar is removed. Also see **Latch needle**.

Sprouting: Defect in Brussels and tapestry rugs and carpets, consisting of some of the loops protruding above the surface.

Spunbond fabric: An alternate name for Spun-laid fabric.

Spun-bonded products: Nonwoven fabrics formed by filaments that have been extruded, drawn, then laid on a continuous belt. Bonding is accomplished by several methods such as by hot roll calendaring or by passing the web through a saturated-steam chamber at an elevated pressure.

Spun-dyed fibres: Man-made fibres dyed in the spinning paste (spun-dyed).

Spun fabric: A fabric made from staple fibres that may contain one or a blend of two or more fibre types.

Spun Glass: Glass thread of great fineness, dyed in various colours, braided and made into neckwear, as in Venice.

Spun laced fabric: A nonwoven fabric made from a staple fibre web or batt bonded by entanglement using high pressure water jets.

Spun laid fabric: A non woven fabric made by the extrusion of filaments which are laid down in the form of a web and bonded.

Spun polyester: Lightweight woven or knitted fabric that have a soft, wrm feel. Comfortable for sports and casual clothes, dresses and nightwear.

Spun rayon: Yarn spun from rayon staple fibres.

Spun silk: This is a type of silk yarn, although the fabric itself may be labeled this way. The yarn is made by breaking up the short fibres of waste silk and spinning them together, and this yarn is then woven into fabric. Although the fabric should be cheaper than silk as it is made from waste yarn e processing is lengthy and hence expensive. The fabric may be produced of any weight.

Spun yarns: A strand shaped structure made from Staple fibre which is held together by twisting



(spinning) as opposed to Continuous filament yarn.

Spunbond Fabric: Random webs.

Spun-dyed: Man-made fibres dyed in the spinning paste (spun-dyed).

Spun viscose: This is really the name of the yarn, but fabric also carry this title. They are in plain weave and may be plain or printed. These fabric were once considered poor in quality and performance but the fabric finishing techniques have improved so much that they are now good fashion fabrics. They are soft and drape well and are fairly warm, but they crease in wear and highly inflammable. Used for dresses, blouses, shirts nightwear, and childrens clothes.

Spyndle number: See **Yarn numbering system**. Count for dry-spun flax yarn and jute yarn, consisting of 48 cuts (or leas) of 300 yards each, which make up a spyndle of 14,400 yards, the weight in pounds of a spyndle being the count of the yarn.

Spyndle number, in jute: A direct yarn numbering system for jute rove and jute yarns in which the number of pounds per spyndle, or fourteen 400 yd (thirteen 167 m) length, is expressed as pounds per spyndle.

Square construction: See **Balanced fabric**.

Squeegee: The portion of a screen-printing apparatus consisting of a blade that forces the print paste through the screen onto the fabric.

Squeegee pass: The movement of the doctor blade from one side of the screen to the other. This movement can be carried out once or several times depending on the substrate, print style and printing press.

Squeegee pressure: Together with the Squeegee contact angle, this controls the amount of printing paste which is applied during flat and rotary screen printing. In the case of the magnetic-rod squeegee system, it is established by differences in the strength of the magnetic field, but in the case of the blade squeegee, it is determined by appropriately adjusted spring pressure (See Squeegee systems in printing).

Squeegee profile: The squeegee profile is characterized by the cross-section of the squeegee rubber. Depending on requirements, synthetic rubbers of different thicknesses are used which lead out on the side turned towards the screen gauze with the edge rounded off or cut flat or steep. Squeegee systems in printing.

Squeeze rolls: Rolls used to apply pressure for removal of water or chemicals from fabric.

Sress-strain curve: A graphical representation, showing the relationship between the change in dimension (in the direction of the applied stress) of the specimen from the application of an external stress, and the magnitude of that stress. In tension tests of textile materials, the stress can be expressed either in units of force per unit cross-sectional area, or in force per unit linear density of the original specimen, and the strain can be expressed either as a fraction or as a percentage of the original specimen length. See also **Load de-formation curve**.

Srinagar: Knotted rugs made in Kashmir, India, of very fine wool.

s/s type fibres side-by-side, Bicomponent fibres.

ST: (1) Tussah silk. (2) Mineral silicate fibres.

Stabilised Yarn: Yarn which has been subjected to heating and cooling or other setting treatment in order to reduce its tendency to shrink, contract. Twist Or snarl.

Stability: A term used to describe the tendency of a fibre or fabric to return to its original shape after being subjected to external influence, such as tension, heat, or chemicals.

Stability To Thermal Oxidation, for polyolefin monofilament: The time-to-failure, when polyolefin monofilaments are exposed to circulating air, at 125°C.

Stability To Thermal Oxidation, for polyolefin fabrics: That property of a fabric which resist breaking under a specified tensile strain, when exposed to a current of air at an elevated temperature.

Stable fabric: A textile fabric, the dimension of which does not change significantly during processing, with multiple passes through measuring devices or during use.

Stabilized Fibre: Fibre that is heat or chemically treated to set the fibre properties and prevent deterioration, shrinkage, etc. Also see **Heat stabilised, Heat setting, and UV Absorber.**

Stabilization, in effluent treatment: The biological process by which the organic matter in the sludge produced in the primary settling and biological treatment of waste water is stabilized, usually by a conversion to gases and cell tissue. Depending on whether the stabilization is carried out under aerobic or anaerobic conditions, the process is known as aerobic or anaerobic digestion.

Stabilizer: In Hydrogen peroxide bleach baths: A chemical compound which when added to an alkaline peroxide bleaching liquor, will control the rate and nature of decomposition of peroxide, thus providing a controlled process of bleaching with minimum tendering of the substrate. These substances are used to regulate the release of oxygen, help prevent oxygen decomposition by catalysts such as copper, manganese and iron, etc. and prevent the loss of oxygen and prevent local fibre damage. Stabilizers are usually not needed in hard water.

Staggered twill: See **Broken twill.**

Stain: An area of discoloration that penetrates the fabric surface.

Stain And Soil Retardancy: Fabric quality of retarding staining and soil.

Stain Blocking: Finishing effect. Active stain blocking prevents penetration of stains and dirt into the substrate (oil-repellent finish). Passive stain blocking

eases the removal of dirt which has got on to, or stains which have penetrated into the substrate (Soil-release finishing).

Stain removing table: A table specially made for the removal of stains on the garments or cutpieces. Usually used in garment industries it will have a Steel Table top provided with steam gun for wet and dry steam, spray guns, vacuum extraction and air blowers, various solvents and air blowers for drying the treated area etc. Steel Table top with perforations or even ss steel mesh as table tops are also used. The table is usually operated with the aid of foot pedals. Most of the stain removing table will have a swivelling sleeve board which also has a vacuum connection to an automatic vacuum vibrating valve which switches on when in use and is automatically switched off again when swivelled away from the working area. Spotting brushes are reserved for special purposes only.

Stain Repellency: Stain Repellency is the ability of a treated fabric to withstand penetration of liquid soils under static conditions involving only the weight of the drop and capillary forces.

Stain Repellent Finish: See **Oil repellency, Oil repellent finish.**

Stainblocker: A chemical substance which, when applied to a textile substrate, imparts partial or total resistance to staining.

Stained Cloth: Antiquated term for drapery painted with figures, to imitate tapestry.

Staining: (1) Any adventitious (unwanted) colour, owing to dye, dirt or iron, on textile material. A severe stain is one that will resist processing. (2) The fugitive or permanent coloring of material for identification purposes.

Stainless Steel: A broad class of corrosion-resistant iron alloys. Stainless steel is often recommended for vessels for dyeing. It is made of iron alloyed with metals such as chromium, molybdenum, nickel, and others. There are a great many stainless steel alloys. The best alloy for chemical resistance is "316S". "316" is almost as good, followed by "308", "304" and "18-8". You will sometimes see these numbers on the packaging or literature for higher quality stainless ware. High chloride ion concentration, particularly at high temperature, can corrode even the best stainless steel. This is unlikely to cause concern for home dyers. Because there is a possibility that stainless steel pots can become pitted from use in dyeing, and the pits may make it hard to completely remove contaminants, such pots should not be used for food purposes. Beware of aluminum rivets that are sometimes used to fasten handles to inexpensive stainless steel pots.

Stainless-Steel Fibre: (non-rusting metal fibres).Stainless steel metal filaments, e.g. metal filaments produced from stainless steel 18/8 or other stainless variants.

Stalagmometer: An apparatus consisting of a glass capillary with a specified orifice which is used to measure the Surface tension of a liquid by the drop method: suitable for dilute aqueous solutions (1–3 g/l). Measurements are based on a comparison, usually against the drop count of pure water: the results can also be converted into absolute values. Principle: low surface tension = smaller drops = a higher drop count. The apparatus is particularly suitable for determining the efficacy of surface-active textile auxiliaries in terms of the drop count and dependence on concentration (at the same temperature).

Stalk fibres: Bast fibres.

Stamped Velvet: Velvet having patterns stamped into the pile with heated engraved rollers.

Standard: A reference against which instrumental measurements are made. Standards are written agreements setting out technical specifications or other clearly defined criteria that are consistently applied as rules, guidelines or designations of properties to ensure that materials, products, processes and services fulfil the intended purpose.

Standard Atmosphere for preconditioning, in textiles: An atmosphere having a relative humidity of 5–25%, $\pm 2\%$ tolerance for the selected relative humidity, and a temperature of not over 50°C (122°F), with $\pm 1^\circ\text{C}$ ($\pm 2^\circ\text{F}$) tolerance for the selected temperature and used to partially dry the material before further treatment or conditioning.

Standard Atmosphere For Testing, in Textiles: An atmosphere for testing in which the air is maintained at a relative humidity of 65 $\pm 2\%$ and a temperature of 21 $\pm 1^\circ\text{C}$ (70 $\pm 2^\circ\text{F}$). (a) Standard Temperature Atmosphere An atmosphere having a relative humidity of 65 $\pm 2\%$ and a temperature of 20 $\pm 2^\circ\text{C}$. (b) Standard Tropical Atmosphere. An atmosphere having a relative humidity of 65 $\pm 2\%$ and a temperature of 27 $\pm 2^\circ\text{C}$.

Standard Atmosphere For Testing, in glass textiles: An atmosphere for testing in which the air is maintained at a relative humidity of at least 45% and no greater than 67 % , tolerance of $\pm 2\%$ for the selected relative humidity, and a temperature of at least 20°C (68°F) and not greater than 25°C (77°F) with a tolerance of $\pm 1^\circ\text{C}$ ($\pm 2^\circ\text{F}$) at the slected temperature.

Standard Condition: The state of being in moisture equilibrium with the standard atmosphere for testing.

Standard Condition for physical testing: The condition of a textile material that has been dried to approximately constant mass in an atmosphere that has a relative humidity not exceeding 10%, and then kept in the appropriate standard atmosphere for testing (q.v.) until it has reached equilibrium. In cases where a textile material is not likely to lose volatile matter other than water, or to change dimensions, the preliminary drying may be carried out in an oven at 50–60°C situated in the standard atmosphere for testing which is a convenient way of achieving a relative humidity of about 10%. When the oven is supplied with the supplementary standard atmosphere, an oven temperature of 60–70°C is required. Equilibrium with the standard atmosphere for testing may be assumed when successive determinations for mass at intervals of at least 2h show no progressive change exceeding 0,25% in the mass of the textile material.

Standard depth scale, in colour measurement: A series of dyed samples of different hue and chroma that have been accepted to have the same depth.

Standard depth of shade: Since dyeings vary in depth, it is common practice to determine a fastness property at a standard colour depth. Variations in the dye content of commercial dyes do not allow standardisation of colour depth of a dyeing on the basis of the % owf of the dye. The ISO recommends a series of reference colours in 20 different hues ranging from yellow to black. The standard depth is called the standard 1/1 depth. Black and navy are only available in two depths. For the other colours, other depths include the 2/1 standard depths, which are twice as deep as the 1/1 standards, or the 1/3, 1/6, 1/12 or 1/25 standard depths that are successively paler. For fastness testing, a dyeing is produced having a hue and strength matching as closely as possible one of the standard colours.

Standard deviation: Standard deviation is defined as the square root of the average of the squared deviations of the observations from the group average. Squaring the deviations eliminates negative signs and concentrates attention on the magnitude of the deviations and not their sign.

Standard Deviation, of a sample: A measure of the dispersion of variates observed in a sample expressed as the positive square root of the sample variance.

Standard dyeing time: [t_{70} -value, t_{70} (0.5)]. A parameter characterizing the dyeing process which is roughly inversely proportional to the dye diffusion constant. It gives the time in min at 100°C (at a liquor ratio of 40 : 1) required to achieve a bath exhaustion of 70% when dyeing is carried out at half the saturation depth (according to Hoffmann).

Standard Illuminant: Known spectral data established by the CIE for four different types of light sources. When using tristimulus data to describe a colour, the illuminant must also be defined. These standard illuminants are used in place of actual measurements of their light source.

Standard light source: See **Standard illuminant**.

Standard Moisture Regain: The moisture regain of a material at equilibrium with the standard atmosphere for testing textiles.

Standard Moisture Regain: Accepted moisture allowance for textile materials expressed in percentages of their dry weight.

Standard Observer 2,10 (CIE): (1) A hypothetical observer having the tristimulus colour-mixture data recommended in 1931 by the CIE for a 2° viewing angle. A supplementary observer for a larger angle of 10° was adopted in 1964. (2) The spectral response characteristics of the average observer defined by the CIE. Two such sets of data are defined, the 1931 data for the 2° visual field (distance viewing) and the 1964 data for the annular 10° visual field (approximately arm's length viewing). By custom, the assumption is made that if the observer is not specified, the tristimulus data has been calculated for the 1931, or 2° field observer. The use of the 1964 data should be specified.

Standard pressure: An internationally agreed value of 101 325 Pa (approximately 100 kPa), equal in non-SI units to a barometric height of 760 millimeters of mercury at 0°C or one Atmosphere.

Standard solution: A solution that contains a known mass of reagent in a definite volume of solution. A standard flask or volumetric flask is used for this purpose. The solutions may be prepared by direct determination of mass for primary standards. If the reagent is not available in a pure form or is deliquescent the solution must be standardized by titration against another known standard solution. See **primary standard**.

Standard temperature: An internationally agreed value for which many measurements are quoted. It is the melting temperature of water, 0°C (273.15 K). See also **STP**.

Standard white: (Ideal white). For comparative reflectance measurements, only those pigments capable of giving a full matt white of 100% white content with as near complete reflection of the incident light rays are used. Relatively few substances are able to satisfy these requirements in practice however. For colour measurement applications, the following two pigments are used as standard whites: (a) barium sulphate (2) freshly prepared magnesium oxide.

Standing bath dyeing: In exhaust dyeing where many batches of the same shades are to be dyed the standing bath dyeing is attractive in both cost reduction and environmental protection. In this method the dyebath is continuously used with the addition of exhausted dye in the previous batch and chemicals if necessary in order to restore the dyebath to its original state and ensure reproducible results.

Standing dyebaths: Dyeing from a standing bath makes use of exhausted dye liquors to produce further dyeings and therefore represents a worthwhile recycling technique. See **Standing bath dyeing**.

Standing Wire: A broad term describing fixed rods or strips extending through the loom reed, that control the height of the pile in a woven pile fabric.

Stannic chloride: (pink salt, tin tetrachloride, tin perchloride, tin (IV) chloride), SnCl_4 , molecular weight 260, density 2.229–2.26. Colorless, waterfree, corrosive, fuming liquid, almost chemically pure with a 45.4% tin content. Evolves heat on contact with water. Uses: mordant for alizarin dyeing, weighting of silk, clearing and softening of silk, manufacture of fuchsin, colour lakes.

Stannous acetate: (tin (II) acetate, acetate of tin), $\text{Sn}(\text{C}_2\text{H}_3\text{O}_2)_2$, molecular weight 236. Aqueous solution. Used as a reducing agent in discharges on substantive dyes (especially black).

Stannous chloride: (tin crystals, tin salt, tin dichloride, tin (II) chloride), $\text{SnCl}_2 \cdot 2\text{H}_2\text{O}$, MW 225, density 2.71. White salt, hygroscopic, soluble in water, powerful reducing agent. Uses: discharge printing, tin mordant (for shading alizarin red and pink on the yellower side to give fiery shades); aftertreatment (with soap) of alizarin red; resists (wool resists); spotting agent.

Stannous oxalate: (tin (II) oxalate), SnC_2O_4 , molecular weight 206.5. Uses: dyeing and printing of textiles; mordant for alizarin print pastes and dyeing (more vivid pink and red shades).

Staple: Natural fibres or cut length from filaments. The staple length of natural fibres varies from less than 1 inch as with some cotton fibres to several feet for some hard fibres.

Manufactured staple fibres are cut to a definite length, from 8 inches down to about 1-1/2 inches (occasionally down to 1 inch), so that they can be processed on cotton, woollen, or worsted yarn spinning systems. The term staple (fibre) is used in the textile industry to distinguish natural or cut length manufactured fibres from filament.

Staple crimp, in wool: (1) General- The natural waves in a grease lock. (2) Specific- One complete wave on undulation of crimped lock.

Staple length: Is the average length of Staple fibre which, in the case of man-made fibres, can be any predetermined cut length. The staple lengths (in mm) of some natural and regenerated cellulose fibres are as follows:

1–5 = jute

5–50 = recovered wool

10–25 = hemp

0–50 = cotton

15–50 = bourette silk

25–45 = flax

30–150 = viscose staple fibre

60–150 = schappe silk

70–200 = ramie

50–300 = wool

approx. 1000 = raw silk

Staple, in grease wool: A tuft or lock of fibres which naturally cling together, as found in a fleece.

Staple, in button: A looped metal shank securely positioned perpendicular to and at centre back of the button flange for use in attaching the button to one part of a flexible substrate by means of a needle and thread, a ring or a toggle.

Staple Fabric: See **Spun fabric**.

Staple Fibre, man made: See **Man-made staple fibre**. Fibre of spinnable length manufactured directly or by cutting filaments.

Staple Fibres, multiple length: See **Multiple length staple fibres**.

Staple Fibre, overlength: Overlength staple fibres. Man-made staple length that are at least 10% longer than the nominal or average cut length.

Staple glass, yarn: Yarn made from filaments that are nominally 200 to 380 mm (8 to 15 in.) in length.

Staple in grease wool: A tuft or lock of fibres which naturally cling together, as found in a fleece.

Staple length in grease wool: The length of a staple without stretching or disturbing the crimp of the fibres.

Staple: The conversion of staple into spun yarns suitable in evenness, size, twist, and strength for use in the weaving or knitting of fabrics. (Also see **Textile processing**.)

Staple Yarn: See **Spun Yarn**.

to as a thickener for some other types of dye. Starches are also chemically processed to produce dextrin, starch ethers (see Monagum) and starch esters. Unmodified starch has very low solubility in water. It is also used in finishing. Its use in all these operations depends on its adhesive or film forming properties and hence different starches (different origin) used for different purposes.

Starch Esters: These are starch products esterified with acetic anhydride, phosphoric acid or other acids which can be used as textile sizing and finishing agents. Starch esters produce more or less free-flowing pastes.

Starch Ethers: Starch ethers are made by reacting the hydroxyl groups in the anhydroglucose ring with appropriate reagents. These reactions add to the hydrophilic nature of the starch and decrease the ability to form hydrogen bonds between polymers, modifying solution and dry film properties. Examples are carboxylated starch, hydroxyethyl and hydroxypropyl starches.

Starch Indicator: Solution that is used to detect starch by a colour reaction. Starch indicator is usually a solution of iodine and potassium iodide in water (typically about 2.3% potassium iodide and 0.33% iodine in distilled water). It will react with starch to produce a violet to blue-black colour, depending on the specific type of starch. This can be useful for detecting starch size in fabrics. Mercerized cotton will also give a blue-black colour with this test, though the colour seems to appear slowly, whereas with starch it appears almost instantly.

Starch Lump: See **Hard size**.

Starch paste: External characteristics: opaque, sticky; iodine reaction: dark blue; solubility: insoluble in water; technical qualities: fibre adhering, pore blocking (suitable for use as a printing thickener), good covering properties, subject to chalking, readily forms dust. The starch films are non-transparent, of average strength and low elasticity.

Starch size: Starch is still the most commonly used sizing agent for the weaving of cotton and viscose fabrics and has the advantage of being biodegradable. The question of Size recycling, as in the case of synthetic sizing agents, does not arise with starch sizes.

Starch sugars: (starch syrup). As the end product of starch degradation, starch sugar is identical to Maltose (malt sugar) and Glucose (grape sugar). External characteristics: aqueous, without body; iodine reaction: colorless; solubility: readily soluble in cold water. Technical qualities: starch sugar has neither a stiffening nor a hardening effect and is hygroscopic.

Star dyeing: A process for dyeing (usually delicate) textile fabrics in Star dyeing machines, especially velour upholstery fabrics and other pile fabrics made of cotton, natural silk, acrylic, polyester, acetate, etc.

Star frame: A frame having radial arms resembling the points of a star with hooks placed fairly close together on each arm. It is used to suspend delicate fabrics, like silk in the open width state in Star dyeing machines, either from one edge (vertical star dyeing machine) or both edges (horizontal star dyeing machine). Starting from the centre of the frame, the fabric is suspended from the hooks to form a spiral batch. For fabrics with sensitive edges, a narrow cotton or linen strip is first sewn along the edge/s to be suspended.

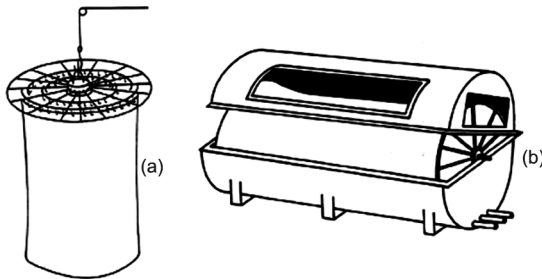

Star frames (a) Vertical (b) Horizontal

Start-Up Mark: See **Set Mark**.

Stash: It is your fabric collection.

Static: An accumulation of negative or positive electricity on the surface of fibres or fabrics because of inadequate electrical dissipation during processing. Static results in an electrical attraction or repulsion of the fibres relative to themselves, to machine parts, or to other materials, preventing the fibre from traveling in a normal path in the process.

Static Adhesion: In tire cord, the measurement of the strength of a cord-to-rubber bond under static conditions or very low strain rate.

Static charge: Whenever two materials are separated an electrostatic charge is developed in between them. The charge can be influenced by various factors like relative humidity, friction, distance between the objects etc. In textile it is important in case of the carpets. When the person walks on a carpet static charges are formed on the shoe and it is distributed all over the person and finally discharged to earth when the person touches any conductive material like door knob or an electronic equipment etc. During the discharge the person can feel a mild shock or it can affect a sensitive electronic equipment. The simplest solution to the problem is to increase the conductivity of the carpet so that when the surfaces are separated the charge is conducted away rapidly and cannot build up further. See **Walk Test**.

Static Crack: See **Shier**.

Static friction: Friction developed between two touching bodies at the time one body starts to move relative to another.

Static load in textile testing: A mass which exerts a force by means a mass alone without motion.

Stature: See **Height**.

Statute Galloons: Narrow cotton or silk braids, used in England for binding flannel underwear.

Stay: A piece of fabric or sometimes a tape used to hold another piece of fabric in place, or to add strength to a seam or tack; corsets.

Staying: Binding Tape to lace women's corsets.

Std Atm. For Preconditioning: See **Standard atmosphere for preconditioning**.

Std. Atm. For Testing: See **Standard atmosphere for testing**.

Steam black: Aniline black produced on the fibre with sodium chlorate as oxidizing agent and yellow prussiate of potash (potassium hexacyanoferrate II) as aniline black catalyst. Steam black is also referred to as prussiate black.

Steam boiler: Various types of steam boiler can be classified a) according to the steam pressure (low-pressure boilers up to 1.5 bar, high-pressure boilers above 1.5 bar); or b) according to the construction (natural circulation; controlled circulation boiler; forced flowthrough boiler).

Steam Calender: A machine used after the drying of finished knitgoods for steaming, compacting and stretching the fabric to the desired tubular width.

Steam Chest: A steam-heated cabinet used in manufactured fibre production. Usually refers to the heated cabinet in which spin-drawing is done or to the cabinet around a stuffer-box crimper.

Steam Cleaning: Often mistakenly used in place of Hot water extraction in the carpet cleaning. See **Hot water extraction**.

Steam Cure Process: A process for the continuous moist crosslinking of cotton with a nitrogen-methylol compound in the presence of a highly active catalyst mixture (magnesium chloride and citric acid) in a steamer supplied with superheated steam for drying and crosslinking (6–10 min at 130–140°C). Reaction takes place in the 15–5% moisture content range. Subsequent neutralization is not necessary.

Steam decatizing: A process in which decatizing is carried out with steam (also known as blowing) in contrast to Wet decatizing.

Steam finisher: An equipment used in garment industry, laundry for batchwise or continuous steaming of outerwear garments. It is a steaming cabinet or steaming tunnel through which garments are passed and a notable finish effect is produced especially in the case of blended fabrics.

Steam-setting method: A heatsetting method. Short staple polyester yarns including polyester/cotton blends are normally set by relaxation in saturated steam. The most effective means of stabilising these materials are to steam at 107°C on the ring spinners tube and soft dyeing packages under minimum tension. Steaming is carried out in an autoclave fitted with vacuum pump, e.g. two times 15 min at 125–135°C with intermediate evacuation or alternatively, for 60 min with saturated steam. Sewing threads receive special setting treatments, designed to confer stability whilst preserving their high tensile properties. Polyester garments, garment lengths and hosiery are also stabilised by steaming in much the same way as for yarns.

Steam trap: Steam traps. A self-acting device which, operating under steam pressure, automatically ejects condensed steam (condensate) from steam pipes, etc. without permitting the escape of steam. Various designs and systems are available, e.g. with float valve, ball valve or slide valve, bimetallic strip control (valve opens with a drop in pressure resp. temperature and closes with a rise in temperature).

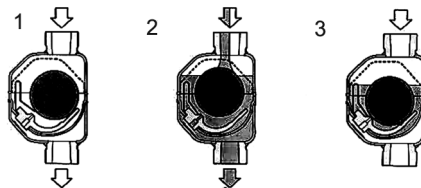

Working of a steam trap. 1. Cold condensate, 2. Hot condensate, 3. Steam

Steamer: (1) A program-controlled yarn steamer with radial through flow to ensure uniformity of the steaming effect. (2) An apparatus for steaming printed or padded piece goods, yarns, tops, hosiery, garments, etc. These steamers are of two types, (a) batchwise or discontinuous steamers and (b) continuous steamers.

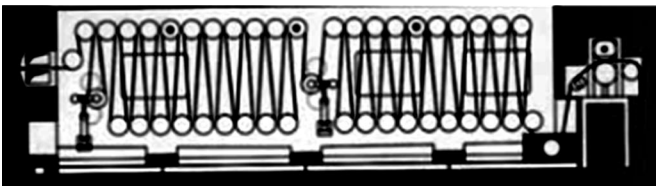

A steamer

Steamer grey: A light woven fabric which is run into a steamer together with printed goods to prevent the dried print pastes on a printed fabric from marking off on to adjacent layers of the same fabric during the steaming process.

Steaming: Finishing process causing general increase in moisture levels, increased swelling, and therefore, further effects, such as improved washing. There are further specific effects on wool-based fibres, including partial alleviation of tension (tension-free steaming), fluffing and raising the pile, removal of creases caused by laying, storage, pressing and decatizing, stripping of shine caused by pressing, etc. The best method to use is to steam for approx. 3 min with saturated steam, but complete saturation of the fibre should be avoided (detrimental effects to the handle).

Steaming at atm. pressure, fastness to: Capacity of the colour shade to resist being affected by steam (e.g. during steaming). The sample is placed between undyed cotton and the adjacent fabric for colour fastness testing. After rolling, the test sample is placed in the neck of a glass cylindrical flask, which is filled with boiling water. It is boiled for 30 min and then dried in warm air (< 60°C) without being touched. Any staining of the undyed adjacent fabric is evaluated using grey scales for fastness testing.

Steaming of prints: Prints are usually set or developed by steaming the various different substrates (details can be found under the relevant dye classification). The steaming process is carried out in open or sealed systems, either at atmospheric pressure or at pressure for temperatures in excess of 100°C.

Stearates: Stearic acid salts, e.g. aluminium stearate, which is used as a water-repellent treatment.

Stearite, soapstone: Mineral mass with a greasy feel, a derivative of Talcum consisting of 60–85% talcum, 5–7% magnesium carbonate, 0–24% barium carbonate, 0–2% lime, 0–2% beryllium oxide. Used to remove grease stains and as tailor's chalk.

Steel cord: A formed structure made by twisting together two or more steel filaments or steel strands.

Steel cord wrap: A filament wound helically around a steel cord.

Steel Fibres: See **Metal fibres**.

Steel strand: A group of steel filaments combined together to form a unit product.

Steeping: In textile processing, steeping is dipping and keeping the material for a stipulated time in water or chemical or a mixed recipe.

Steeple: Tall, conical women's head-dress with a flowing veil.

Steiner Tunnel Test: Method for testing the burning properties of carpets. The specimen is exposed to open flames in a tunnel. See **Flammability test**.

Stem stitch: In embroidery stitches placed next to each other to imitate the twine of a rope. Work from left to right, taking regular slightly slanting stitches along the line of the design. The thread always emerges on the left side of the previous stitch. This stitch is used for flower stems, outlines, etc. It can also be used as a filling, rows of Stem Stitch worked closely together within a shape until it is filled complete.

Stencil printing: Stencil printing was developed by the Japanese. Designs are cut in stencil paper which is coated with wax. The stencil designs are placed on fabric and colour is applied by sponge, air brush or by spray gun. This method is done on minimum fabrics like scarves and similar products.

Stenter: An open-width fabric-finishing machine in which the selvages are so held by attachments to a pair of endless travelling chains that the fabric is finished to a specified width.

(a) Attachments may be pins (pin stenter) or clips (clip stenter).

(b) Such machines are used for:

- (i) Drying;
- (ii) Heat-setting of thermoplastic materials;
- (iii) Fixation of chemical finishes.

See **Tenter**. There are different type of stenters: Horizontal stenter, vertical stenter, tier stenter, double return stenter. There are special stenters for knit goods.

Stentering: The process of drying textile fabrics on stenter driers; See **Stenters**.

Step-And-Repeat Machine: The step-and-repeat machine has a print roller pre-prepared with light-sensitive paint, upon which the positive slide is placed and exposed.

Step-Growth Polymers: As the name suggests, the step growth polymerization involves stepwise intermolecular condensation, taking place through a series of independent reactions. Each reaction involves a condensation process involving the loss of a simple molecule like H_2O , NH_3 , HeI , ROH etc. This type of polymerisation occurs if the monomer molecules have more than one similar or dissimilar functional groups. The step growth polymerisation starting with two monomers A and B as :

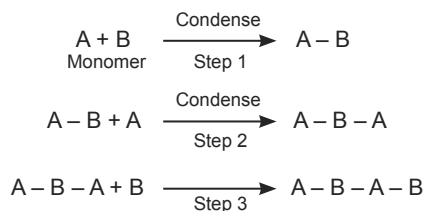

The stepwise process of chain growth thus goes on. This process can also occur in another way :

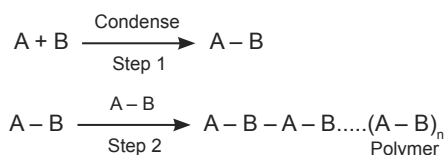

Stephanie Lace: Modern handmade lace in imitation of the Point Venise.

Stereochemistry: Applies to the spatial arrangement of atoms within the molecule structure, e.g. Stereoisomerism; Isomeric compounds; Isotactic polymers.

Stereoselective polymerization: In this type of polymerization one type of ordered structure is preferentially formed in contrast to the other.

Stereospecific polymerization: Polymerizations which yield ordered structures (isostatic or syndiotactic).

Stewart: Various Highland tartans, composed as follows:

Stewart, Royal: Wide red stripe; light blue stripe, almost one-eighth of the red; black stripe, wider than pale blue; group of yellow, black, white and black lines; green stripe, about one-quarter of wide red stripe*; red stripe, twice as wide as the green, split by one fine white line (in the center) and two, somewhat heavier black lines, the three lines spaced evenly; repeat, in reversed order groups mentioned between the two*. Old Stewart: Dark brown stripe, edged by red lines and split by a finer red line; dark green stripe, twice as wide as the former, divided into three even parts by two dark blue stripes, each edged by black lines; dark brown stripe, as above; dark blue stripe, split by two groups of narrow stripes, each group consisting of three black and two grey.

Stick-slip: Phenomenon occurring when boundary lubrication is deficient, manifested by alternative periods of sticking and slipping of the surfaces in contact.

Stiffened Fabrics: Stiffening Interlinings between the top cloth and the lining, Front fusing.

Stiffened Linen Extremely strong Buckram, board-like, hard, barely flexible, used for stiffening uniform collars.

Stiffening Agents: Used specifically for finishing and sizing. There are different types (a) Vegetable colloids: starches, mucilages, mosses, algae, gums. (b) Animal colloids: glue, gelatine, casein, protein sizes. (c) Synthetic colloids: polyvinyl products and similar, cellulose derivatives, synthetic resins.

Stiffness: Resistance to bending. (rigidity, flexural rigidity). Flexural rigidity is a measurement of the resistance exhibited by a material when subjected to bending.

Stilb: Unit of Radiant intensity per unit area. Radiant intensity is defined as the quotient of candela and square metres: $L = 1 \text{ cd/m}^2$.

Stilbene: (trans 1,2 diphenylethylene) Most of the Optical whitening agents are stilbene derivatives. They are usually derived from diamino stilbene disulphonated acids and as such they don't have any fluorescent property but an amino group is added on to the two benzene structure it shows fluorescent properties.

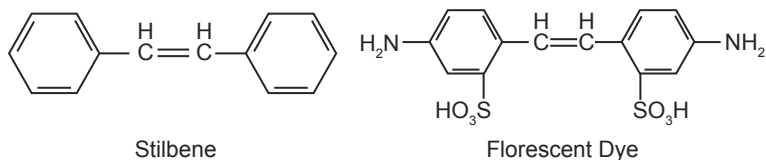

Stilbene dyes: Stilbene dyes are in most cases mixtures of dyes of indeterminate constitution that are formed from the condensation of sulfonated nitroaromatic compounds in aqueous caustic alkali, either alone or with other aromatic compounds, typically arylamines. The sulfonated nitrostilbene is the most important nitroaromatic, and the aminoazobenzenes are the most important arylamines.

Stiletto: This is a pointed metal with a wooden handle and is used to make eyelet holes or openings.

Stitch: The repeating unit of sewing thread formation in the production of sewn seams and stitching.

Stitch, in knitting: Stitch: stitch is the smallest unit in knitted fabric. A knitted fabric surface is formed by repeating it, side to side and one on top of the other. It consists of loop head, loop leg and loop feet. Plain stitch: this is

the technical face side of stitch where loop legs are above the neighbour stitch and loop head is below the neighbour stitch.

Stitch, in sewn seams: The repeated unit formed by the sewing thread(s) in the production of seams.

Stitch (Backstitch): Used at the beginning and end of stitching to reinforce and prevent raveling. Also called backtack or stay-stitch.

Stitch (aste): A stitching which holds the fabric in place until permanent stitching has been completed.

Stitch, Blind: A stitch that is not visible on one side of the fabric.

Stitch, Chain/Class 100: A stitch formed with one or more needle threads, the loops of which are passed through the material and through the loops of the preceding threads.

Stitch, Contrasting: When the stitching thread contrasts the garment colour.

Stitch, Double lock/class 400: A stitch formed with two or more groups of threads that interlace each other. The loops of needle thread are passed through the material where they are secured by looper threads; no bobbins used. This stitching ravel in one direction.

Stitch, Flat seam/class 600: Multi-needle stitches that provide the elasticity necessary for knits.

Stitch, hand/class 200: A stitch formed by hand with one or more needles---one thread per needle passing in and out of the material.

Stitch, Lock/class 300: A stitch formed with two or more groups of threads that interface each other. The loops of needle threads are passed through the material where they are secured by bobbin threads.

Stitch, overedge/class 500: A stitch formed with one or more groups of threads at least one of which passes around the edge of the material.

Stitch, safety: A combination chain-stitch and overedge stitch made simultaneously on the same sewing machine.

Stitch, Top: A second row of stitching close to the edge of a seam, after two or more pieces of fabric have been sewed together and turned to bury the raw seam margin side.

Stitch, Zig-zag: A stitch made on a sewing machine in which the needle bar comes down alternately on the right and left side of an imaginary center line. Also refers to the type of machine producing this stitch.

Stitch Bonding: A bonding technique for nonwovens in which the fibres are connected by stitches sewn or knitted through the web. Also known as quilting.

Stitch density, in knitted fabrics: Stitch density: this is a product of course density and wale density. It gives a total number of stitches in a square area of fabric. Stitch density tends to give more accurate measurement for fabric dimensions compared to course density and wale density, due to the fact that the adverse effect of tension on the course and wale densities may be eliminated.

Stitch density, in sewn fabrics: The number of stitches per unit length in one row of stitching in the seam.

Stitch gauge, in sewn fabrics: The perpendicular distance between adjacent parallel rows of stitching.

Stich in the ditch: Stich in the ditch is a technique for quilting the quilt top, batting and fabric back together by stitching very close to a seam or appliquéd edge on the top of the quilt.

Sticker: A distortion in the weave characterised by tight and slack places in the same warp yarns.

Stick-Slip: A phenomenon that occurs when boundary lubrication is deficient and manifests itself by alternate periods of sticking during which time the frictional force slowly rises to a peak value and slipping where the frictional force rapidly decreases to a minimum value.

Stitch type: A numerical designation relating to the essential characteristics of the interlacing of sewing thread(s) in a specified stitch.

Stitch Balance: Refers to the balancing of the sewing machine tension systems so that a proper stitch is formed. Generally, it is desirable to balance the stitch with minimum sewing machine thread tension.

Stitch Gauge, in sewn seams: The perpendicular distance between adjacent parallel rows of stitching.

Stitch Bonded Carpets: Loop pile carpets manufactured using the stitch-bonding technique. The stitch-bonded fabrics are then bonded on the reverse side and coated.

Stitch Bonded Fabric: A multicomponent fabric, one component of which is a series of interloped stitches running along the fabric length. The other component may be fibre web or batt, yarn or preformed fabric. Examples of stitch bonded fabrics are: (a) A film web or batt bonded by stitching yarns (arcane, maliwatt); (b) Cross laid yarn with or without machine direction yarn bonded by stitching yarns (malimo); (c) A structure in which either sewing yarns or other threads lying in the machine direction, are taken over sinkers

to form a loop pile (araloop, malipol); (d) A structure in which the stitching loops are formed from the fibres of the web or batt (arabeva).

Stitch-bonded nonwovens: Nonwoven fabric bonded with chain-stitch seams (stitch-bonding technique using long fibres, not sewing thread).

Stitch-bonded pile fabrics: In principle the many different qualities of stitch-bonded pile fabrics can be divided into the following categories: – type used for floor coverings, – type used for rear window shelves, – type used for car boot upholstery.

Stitch-bonded thread-layer fabric: Stitch-bonded fabrics made from criss-crossed thread layers piled on each other as a backing material, bonded with the stitches formed by warp threads that are sewn in.

Stitch-bonded weft pile fabrics: Stitch-bonded fabrics (Stitch-bonded composites) in which threads formed into pile loops are bonded to the backing material by means of sinker loops created by a pillar stitch chain.

Stitch bonding: A method of stitching webs of fibres together, resulting in a non-woven fabric.

Stitch Course: Stitches arranged adjacently to one another. In standard knitting they are formed consecutively, in warp knitting they are formed at the same time. The number of stitches in the stitch course is dependent on the stitch size.

Stitch density, in sewn seams: The number of stitches per unit length in one row of stitching in the seam.

Stitch density: Construction characteristic of all knit fabric types; calculated as the product of the stitch course count and the stitch wale count. This figure represents the number of stitches within an area of 100 cm².

Stitch gauge: This is the total stitch count (= needle count) per 11/2 inch (Engl.) = 3.81 cm fabric width. This stitch fineness is known as Gauge (g), which can also be abbreviated to gg. The higher the gg number (usually between 36 and 66), the more stitches there are in the knitted fabric, it is finely woven and therefore has better elastic properties. See **Cover factor**.

Stitch length (Loop length): This is the yarn length used in one stitch. It is generally calculated by dividing the course length, which is the yarn length used in one course, into the number of needles used in that course length. Loop length is very important in determining the fabric dimension, since fabric parameters such as course density, wale density and fabric weight are affected by the loop length.

Stitch sewknit fabrics: Variant of Malimo fabric, manufactured for instance from weft layers sewn (using pillar stitch) with woven fabric, Malimo fabric, expanded foam, fleece or knitted fabric as a basis fabric. Synthetic sewing thread is usually used. Use: imitation fur fabrics, friezé for coats, suedette, corduroy, upholstery fabrics.

Stitch type: A numerical designation relating to the essential characteristics of the interlacing of sewing thread(s) in a specified stitch.

Stitch wale: Stitches arranged above each other made by the same needle. The stitch wale count is dependent on the distance between the needles.

Stitch width: The distance between two Stitches, also characterized by the number of stitches per cm or inch. Mesh number. This is important in screen gauzes, for instance.

Stitch, Back-and-fore: A hand stitch employed for sewing linings and pockets. It involves taking a backstitch and the running stitch before the needle is removed.

Stitch, back: A hand stitch used to seam garment parts. So called because the needle, on emerging goes back to be inserted at the end of the previous stitch.

Stitch, blind: A stitch (either by hand or machine) which does not go right through the material.

Stitch, chain: A stitch formed with one or more needle threads and characterized by intralooping. One or more loops of thread are passed through the material and secured by intralooping with a succeeding loop or loops after they are passed through that material.

Stitch, covering chain: A type of chain stitch produced on twin or multineedle machines used for covering seams.

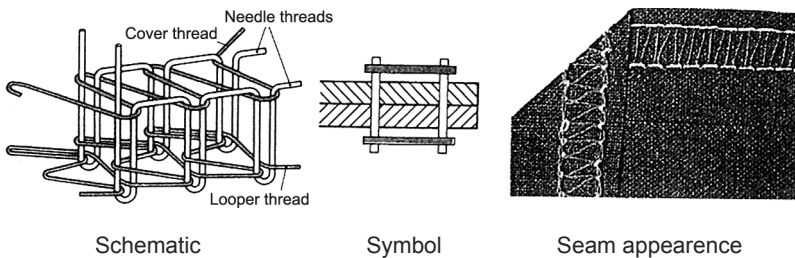

Stitch, cross: A handstitch formed by passing the needle alternately on and off the edge slightly through the material and in advance of the last stitch. Used as a substitute for falling or ornamentation of raw edges.

Stitch, Fagot: A form of lock stitch using modified zig-zag machine, for joining materials, allowing a narrow gap between two edges.

Stitch, Feather: A decorative stitch, similar to the fagot stitch, but in which the joining of two edges is not involved.

Stitch, in sewing: The configuration of the interlacing of sewing tread in a specific repeated unit.

Stitch, in knitting: Stitch is the smallest unit in knitted fabric. A knitted fabric surface is formed by repeating it, side to side and one on top of the other. It consists of loop head, loop leg and loop feet.

Stitch, Flat lock: A stitch formed by the 'flat lock' machine with four needles, four loopers and a covering thread.

Stitch, four thread Overedge: See **Stitch, Mock safety.**

Stitch, Lock: The plain stitch in which two separate threads are used. In formation one thread is passed through the material forming a loop on the underside, second is passed through the loop on the underside of the material. This loop is pulled into the material bringing with it the locking thread.

Stitch, Loop: A type of handstitch used for oversewing edges so as not to increase their thickness by having an edge turned in.

Stitch, Mock safety (four thread overedge stitch): A type of overedge stitch which has an appearance similar to that of a safety stitch on the top surface of the material but has a common looper thread joining the two rows of stitching which can be seen underneath the fabric.

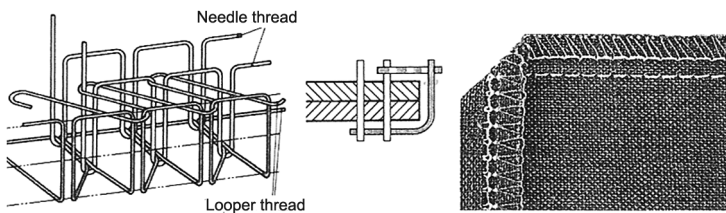

Schematic

Symbol

Seam appearance

Stitch, Single thread Overedge: A type of chain stitch, in which the needle thread loop is carried from the underside of the fabric over the edge and turned to the line of stitching to be secured by the needle on its next downward stroke. Varying amount amount of edge cover can be obtained by using machines employing more threads.

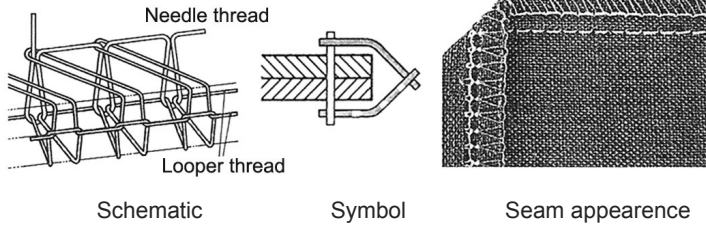

Stitch, three thread Overedge: See **single thread overedge stitching**. Here three threads are used in stitching.

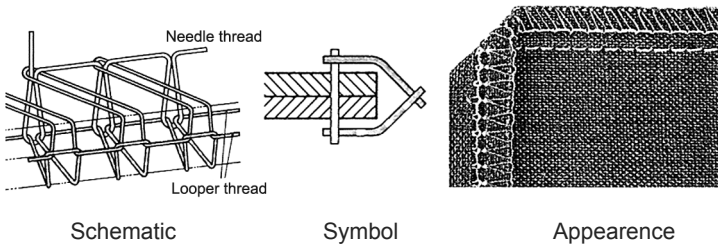

Stitch, two thread Overedge (edge looping): Here two threads that are used in stitching

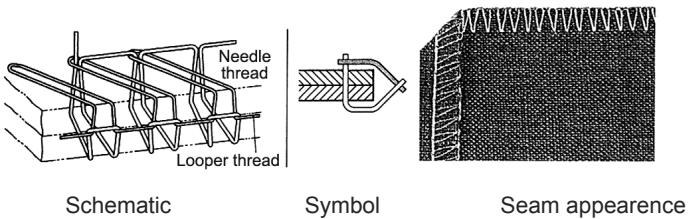

Stitch, two thread Overedge and double chain (Combination safety stitch): Safety seams are a combination of two stitch types. Thread consumption can be upto 16 m thread per 1 m seam.

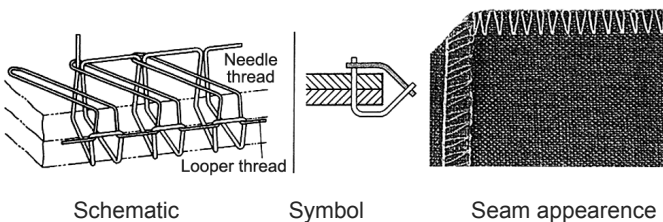

Stitch, two needle multithread chain: Two or more needle are interlaced on the underside by a looper thread on the needle side by a cover thread.

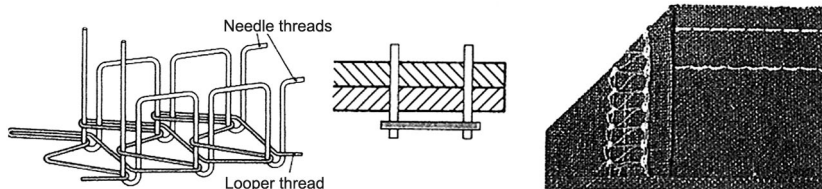

Stitch, plain: This is the technical face side of stitch where loop legs are above the neighbour stitch and loop head is below the neighbour stitch.

Stitch, Prick: A stitch made by passing the needle straight through the material at right angles to the surface alternately from one side to the other.

Stitch, Running: A stitch formed by an overedge stitch reinforced by a chain stitch (or sometimes a lock stitch) further in from the material edge.

Stitch, Skipped: A stitch which appears twice as long as the other stitches in a line of stitches. It is caused by failure in the stitch formation allowing the needle thread to return to the surface without being held by the bobbin (lower) thread.

Stitch type, in sewn seams: A numerical designation relating to the essential characteristics of the interlacing of sewing thread(s) in a specified stitch.

Stitched and pinked seam finish: Used for fabric which has a tendency to ravel, it is a finish for the raw edges of the seam allowances of a plain seam, in which each raw seam allowance edge is machine stitched and then cut to a zig-zag raw edge. Using a sewing machine thread with thread to match your fabric and pinking shears stitch a line of straight machine stitches 6 mm. (1/4 in.) in from the cut edge. Use short stitch, 15 stitches per inch. Pink just on the edge of the seam allowance, taking care not to cut into the stitching.

Stitched seam: See **Sewn seam**.

Stitchel: Hair-like wool with little serrations on the surface.

Stitches: Thread loops that are linked together and constitute the smallest units of Knitted fabrics. They consist of 1 head (upper part), 2 shanks (middle part) and 2 feet (lower part); each having 4 bonding points (2 upper and 2 lower, i.e. at the top and bottom).

Stitches Per Inch: Refers to the number of the stitches made in one inch of seam, starting at a needle penetration and measuring the lengths of thread between needle penetrations.

Stitches, in tufted pile floor coverings: The number of pile tufts per inch in the lengthwise direction.

Stitching: A series of stitches embodied in a material or materials of planar structure such as woven textile fabrics, usually for ornamental purposes or finishing an edge, or both.

Stock colour: Print paste with a high concentration of dye (large quantities are usually kept in stock), used in combination with other stock colour pastes or Reduction thickeners as mixes.

Stock dyeing: See **Dyeing**. The process of dyeing fibres in raw state (in the grain) before being spun.

Stock in process, in textiles (spinning): Staple fibres at any stage of manufacture between the opening of the bale and the completion of the spinning process.

Stock paste Print pastes consisting of all the necessary chemicals except for the dye.

Stock solution: A solution of known strength, made up with the intent of dilution or mixing before final use. Stock solutions are a convenient way of avoiding the need to weigh chemicals each time you need to use some. For example, if you need 0.27 grams of Smurf extract in a blue dye formula, and you have a stock solution of 10% extract, you would measure 2.7 milliliters of stock solution to get that amount. Some chemical solutions have limited shelf life.

Stock thickener: (stock thickening). Printing thickeners containing setting chemicals (large quantities are usually kept in stock), to which dye is added at a later point, in powder, paste or solution form.

Stock vat: It is not possible to vat individual vat dyes in a dye bath, they need to be dissolved in concentrated form. This method is known as stock vatting.

Stockinet: A plain, elastic texture made on a knitting frame, used for underwear, etc.

Stockinette: A knit fabric in tubular or flat form made with a plain stitch from yarns of wool, cotton, manufactured fibres, or a combination of these fibres. Stockinette fabrics are used for underwear, industrial applications, and other purposes. In heavier constructions, dyed and napped stockinette finds apparel uses.

Stocks: Solid silicon rubber compounds, which can, for example, be forced through calenders to coat fabrics.

Stola: Womens outer robe in the form of a shift, worn belted over the tunic.

Stoll-quartermaster universal wear tester: A versatile testing apparatus for measuring wear resistance of fabrics, yarns, thread, etc. It can be equipped with either of two testing heads, one for testing abrasion resistance of flat surfaces and the other for testing resistance to flexing and abrasion.

Stolling: Rib trim put on so that the rib is at right angles to the direction of the rib on the body.

Stomacher: Lengthening of the lower bodice front into a pointed or rounded peak.

Stone finish: A finish obtained by vigorous tumbling with pebbles.

Stone polishing: In print roller manufacture, the polishing process on copper print rollers during Copper electroplating. It occurs when agate stones (rolls) are pressed onto rotating rollers, causing the copper crystals that form vertically to be polished.

Stone washed fabric/garment: Denim fabrics (Jeans) dyed with indigo or other dyes are sized with a large quantity of starch and manufactured into garments. Once the textile has been made into a garment it is desized immediately (30 min at 60–70°C) and then treated with sodium hypochlorite. The technique is known as “Stone-Wash” or denim finishes because pumice stones are used as an abrasive agent to achieve special effects (1 kg of stone or sand per kg of fabric). The bleaching effects can be altered by varying the pH and liquor temperature of the sodium hypochlorite bath. The higher the temperature and the lower the pH (pH 8), the stronger the bleaching effect and the attack on the fibre. There are many other methods (mechanical, chemical, enzymes, or a combination of these) to make stone wash effect made today on any type of dyed materials like pigment dyed, reactive dyed, double dyed etc.

Stop mark: A visible range in the density of the weave across the width of the fabric caused by the tension on the warp not being adjusted properly after the loom has been stopped. See **Set mark**.

Stop motion: Any device that automatically stops a textile machine's operation on the occurrence of a yarn break, a high defect count, etc.

Stop, in Zipper: The device at the top and bottom of the chain or stringer that prevents the slider from leaving the chain.

Stop, Bottom, in Zipper: See **Bottom stop**.

Stop, Bridge top, in Zipper: See **Bridge top stop**.

Stop, Releasing, in Zippers: See **Releasing stop**.

Stop, Top, in Zippers: See **Top stop**.

Stopping motions: Electrical or mechanical devices employed on many textile machines when a fault develops in raw material feeding, arrangements

(openers, scutchers, spinning frames etc.) or a yarn breaks in winding, warping, weaving etc.

Store lighting : (TL 84), type of lighting for colour matching booths, defined as cool, white fluorescent light at a colour temperature of 4400 K. Some customers may ask colour matching of dyed/printed samples in these lights..

Storm Serge: In the United States a very light serge weighing about 7 ounces, made of single warp and filling; used for women's coats.

Storm Shell: Wind proof, wind resistant outerwear.

Stormwater, storm water: Water from any form of *precipitation*. In wastewater engineering it means the *overland flow* that enters the sewers, which can be estimated from the *rational method* or from *unit hydrographs*.

Stormwater drain system: Gutters, *stormwater sewers*, *combined sewers*, streams, ditches, etc. that are used to carry stormwater.

Stout: A property of certain fabrics, being the combination of close weave and weight.

Stoving: The process of bleaching raw wool or fabrics with sulphur fumes.

Stoving fastness: Level of resistance against the influence of sulphur dioxide. The guideline applies to wool and silk, even when mixed with other fibres. The fabric sample undergoing testing must be wetted for 5 min at 25°C in soap solution and squeezed at 100% liquor uptake. Fabric sample and control sample is then exposed to an environment containing sulphur dioxide for 16 h. Fabric samples are hung for 2 h in air without rinsing. Textile mixes are rinsed for 10 min after sulphur treatment and then dried at 60°C. The result is analyzed using the grey scale method.

STP: (NTP) Standard temperature and pressure. Conditions used internationally when measuring quantities that vary with both pressure and temperature (such as the density of a gas). The values are 101 325 pascals (Pa) (approximately 100 kPa) and 0°C (273.15 kelvin). See also **Standard pressure**; **Standard temperature**.

Stradella: A French woollen damask shawl.

Straight draws: These form the simplest and most common method of drawing-in. We begin with the first heddle on the left side of the shaft *nearest to the warp-beam*, then take the first heddle of second shaft and so on until all the shafts the set contains are used in rotation. This completes one "draw," and this operation is repeated until all the warp-threads are taken up.

Straight stitch, in embroidery: This is shown as single spaced stitches worked either in a regular or irregular manner. Sometimes the stitches are of

varying size. The stitches should be neither too long nor too loose. This stitch may also be worked on evenweave fabric.

Straight stitch, in sewing: A simple machine stitch pattern of straight, single stitch segments of equal length. The simple machine stitch pattern is by the down and up movement of the needle while the fabric moves through the feed mechanisms in either the forward or reverse direction.

Straightness in steel cord: The property of a cord characterized by a lack of deviation from its central axis over short lengths of a cord.

Strain: Deformation of a material caused by the application of an external force.

Strain recovery curve: See **Tensile hysteresis curve**.

Strain, Tensile: A relative length deformation exhibited by a specimen subjected to a tensile force strain is expressed as a fraction of normal length; also as a percentage.

Strand: (1) A single fibre, filament, or monofilament; (2) An ordered assemblage of textile fibres having a high ratio of length to diameter and normally used as a unit, including slivers, rovings, single yarns, plied yarns, cords, braids, ropes, etc.

Strand, Irregularity, in textiles: Variation in a property along the strand.

Strand, in braided rope: One of a number of similar units which are intertwined to produce a braided rope, each unit consisting of one or more yarns which are not twisted together and which follow a prescribed path through the braided rope etc.

Stranfa: Fibre obtained from straw; used in Germany as substitute for jute.

Strapping: Narrow width rib trim, usually 1 x 1 rib or of a half milano construction, applied so that the rib runs along the garment lengthways.

Strasse: Sort of floret silk obtained by converting dupions into waste.

Straw A general term for plant fibres obtained from stems, stalks, leaves, bark, grass, etc.

They are made into hats, bags, shoes, mats, etc., by weaving, plaiting, or braiding.

Strazza: See **Bourre**.

Strazza (Italian): Waste of silk in Italy.

Streak: A stain (rust, oil, dye, grease, soap etc.) extended as an irregular stripe in the cloth.

Streak Stitch: The open veins of leaves in hand-made laces.

Streak: An extended unintentional stripe of narrow width, often a single yarn.

Strength: A generic term for the ability of a fabric to resist strain or rupture induced by external forces.

Strength analyzer: An instrument which determines the tensile strength and elongation at breaking load for a test beard of cotton.

Strength count product: See **Break factor**.

Strength, Breaking: (1) The maximum internal cohesive forces of a material which resist rupture during a tensile test.

(2) The ability or capacity of a specific material to withstand the ultimate tensile load or force required for rupture. Breaking strength is particularly significant as the characteristic of a sample as distinct from a specimen.

Strength, Bursting: (1) General: The ability of a material to resist rupture by pressure. (2) Specific : The force applied at right angles to the plane of the fabric under specified conditions.

Strength, Tearing: See **Tearing strength**.

Strength, Tensile: See **Tensile strength**.

Streptocyanine dyes: Dyes in which both charged terminal atoms are not part of a heterocyclic ring are called streptocyanine dyes.

Stress: The resistance to deformation developed within a material subjected to an external force. Typical examples are tensile stress, shear stress, or compressive stress. Stress usually reaches a maximum at the time of rupture. When a textile material is subjected to a stress below that causing rupture, the stress gradually decreases or decays with time.

Stress-Strain Curve: A graphical representation of the stress and strain relationship of a material under conditions of compression, shear, tension, or torsion. A graphical representation, showing the relationship between the change in dimension (in the direction of the applied stress) of the specimen from the application of an external stress, and the magnitude of that stress. In tension tests of textile materials, the stress can be expressed either in units of force per unit cross-sectional area, or in force per unit linear density of the original specimen, and the strain can be expressed either as a fraction or as a percentage of the original specimen length. (Also see **Load deformation curve**.)

Stretch: General term for elastic textiles made from stretch yarn or stretch fabric, for instance. Slimline clothes are frequently fashionable, which means that stretch garments are popular in the ladies' outerwear fashion sector. Polyurethane elastomer fibres have a better chemical resistance, a higher level of elongation and better recovery properties than rubber thread, which was commonly used in the past.

Stretch Breaking: In conversion of tow-to-top, fibres are hot stretched and broken rather than cut to prevent some of the damage done by cutting.

Stretch cord: Collective term for different qualities of elastic cord. Depending on elasticity they are ideally woollen or cotton and textured polyamide, in addition the warp contains 2–6% elastic thread covered with textured polyamide. Example: Warp – approx. 85% textured polyamide and 15% elastomer yarn (elasticity 15–30% depending on quality); overall composition: 80% cotton, 16–17% polyamide, 3–4% polyurethane (elastomer fibre).

Stretch fabric, Woven: See **Stretch woven fabric.**

Stretch fabrics: (elastic fabrics), elastic textiles with comfortable wearing properties (retain shape and are crease-resistant), elasticated either lengthways/warp (ideally) and/or crosswise/weft. The yarns used for this are highly-elasticated synthetic textured yarns, elastomer and rubber thread wrapped with yarn, or corespun yarns, frequently in the form of synthetic mix yarns, with/without natural or synthetic fibres, and also specialist wool and cotton yarns (e.g. with Slack mercerization), etc. See Power stretch, comfort stretch.

Stretch ratio, Draw ratio: (1) Machine draw ratio: In a drawing process, the ratio of the peripheral speed of the draw roller to that of the feed roller (2) True draw ratio: In a drawing process, the ratio of the linear density of the undrawn yarn to that of the drawn yarn. (3) Residual draw ratio: The draw ratio required, in draw texturing, to convert a partially oriented yarn into a commercially acceptable product.

Stretch spinning: A term used in the manufacture of rayon. Rayon filaments are stretched while moist and before final coagulation to decrease their diameter and increase their strength.

Stretch stitch, in sewing: A complex machine stitch pattern or of various combinations of straight stitch, single stitch zigzag, or multiple stitch zigzag. It is produced by co-ordinated motions of needle and feed mechanism in forward or reverse direction.

Stretch towelling: A knit fabric with short loop pile to give it a thin Terry toweling appearance on the right side. It is produced in plain colours and in patterns and stripes. Made from cotton and polyamide, it has a great deal of stretch. Very useful for baby clothes, children's clothes, sports outfits, jumpsuits, bath robes etc.

Stretch woven fabric: A woven fabric which is capable of at least 20% stretch either in warp or weft direction, or both, under loads and conditions encountered in use, and of almost complete recovery on removal of the load.

Stretch yarn: See **Bulk yarn.** Yarns with exceptional elasticity, e.g. Textured yarns; Core-spun yarns Continuous filament synthetic yarns that have been altered through special treatments or modification to give them elasticity. Techniques include: twisting and untwisting, use of air jets, stuffer boxes,

knife blades, crimping, heat setting, curling, steaming, or looping. Use of these yarns gives fabrics a degree of elasticity and comfort.

Stretch yarns, dyeing: Usually in the form of tubeless cross-wound yarn packages (muff) on pack system dyeing machines with a cylindrical yarn carrier in the pack dyeing system (brick-type) or a packing system onto dye tubes.

Stretch, comfort: Stretch fabrics having, lower elasticity, yield on stretching, no body-shaping properties but mould to fit the body, used in ladies' hosiery, underwear, sportswear and outerwear.

Stretch, low power: See **Low-power stretch**.

Stretch, power: Stretch fabrics having high level of elasticity, with bodyshaping properties, for corsetry, swimwear, surgical stockings.

Stretch-spun fibres: Synthetic threads that have been stretched during wet spinning to increase their strength and fineness, e.g. cupro filaments and highstrength viscose fibres.

Stretched filling: See **Tight pick**.

Striations: Streaks or bands of various nature in fibres or fabrics.

Strié: A term describing any cloth having irregular stripes or streaks of practically the same colour as the background.

Strike: Term referring to the speed of dye uptake on the substrate (Half-dyeing, time of). First strike is the ending, which depends on substantivity, in padder dyeing.

Strike off: (1) Sample prints on fabric for pattern and colour approval.

(2) (knocking-over), term originating from old-style hand or block printing. Colour is applied to the print block in the colour trough, and the print is then positioned on the fabric. The print is strengthened by hitting the block with a small hammer, which transfers the dye onto the fabric. Nowadays the term strikeoff is used to mean the printing of a repeat run.

String: (1) Two or three-ply coarse thread of hemp or flax of various thickness and fineness; (2) A unit of ten feet, according to which woollen warps are calculated in Yorkshire, England.

Stringer, In Zippers: The tape, bead and element assembly that constitutes one side of a chain.

Stringy: (1) Thin, delicate stapled wool; (2) A flaw in the wool, consisting in slight matting, caused by imperfect scouring; (3) Defective raw cotton, the fibres forming strings, caused through the ginning of too wet cotton.

Stringy selvage: See **Slack selvage**.

Strip Test, in fabric testing: A tensile test in which the full width of the specimen is gripped in the clamps.

Strip test, Cut: See **Cut strip test**.

Strip test, Ravelled: See **Ravelled strip test**.

Stripback: See **Broken filament**.

Stripe Braid: Has stripes, often of different colours or materials interlaced with each other.

Stripping Yarn: Any yarn plain or fancy, used singly or as small number of threads and made from any textile raw material, to produce stripe effects in a fabric.

Stripper, in textiles: A product usually a reducing agent. That changes the coloring material, dye, or soil stain to reduced colour.

Stripping: Removal of dye from fabric Stripping is usually done with a reducing agent such as thiox, formosul or sodium hydrosulfite and often requires hot to boiling conditions. Some dyes are difficult to strip, and the result often is not white.

Stripping agent: (decolorizing agent). A product for Stripping of dyeings and prints. Reduction bleaching agents on a sodium dithionite basis or hypochlorites are usually used.

Stripping auxiliaries: is used to aid the Stripping of dyeings and printing. Has the task of supporting the brightening effect in the stripping reduction process by restricting the re-uptake of reduced, dissolved dyes. Sometimes also combined with Fibre protective agents, principally in wool. The addition of anthraquinone might be recommended in the stripping of naphthol, vat dyes, etc.

Stroll, in tufting: A pattern attachment consisting of a number of yarn roller which are capable of being driven at different speeds. The pattern is read from an acetate sheet on a pattern drum.

Strong wool: A term with several meanings including extra long staple wool from any wool clip, an Australian term for crossbred sheep, and description of British lustre wools.

Structured needle Felt: A pile fabric formed by subjecting a previously needled web or batt to a further punching operation with forked, single barb or side-hook needles. Rib, velour and pattern structures may be produced.

Studio: The place where a designer works. It can be anything from an area set aside on the factory floor to a large smart office, or even a suite of offices.

Strussa: Waste silk, obtained from double cocoons (duppions).

Strusa (Italian): See **Frisoni**.

Stubble, in shorn floor covering: The portion of the pile that remains after shearing.

Stubble Height: The distance the stubble extends above the backing fabric.

Stuff: An old eighteenth century word used to describe any fabric containing worsted yarns.

Stuffer box: A crimping device consisting of a confined space into which a tow, converted tow, a sliver, a yarn or a similar assembly of filaments or fibres is injected by feed rollers or other means such as fluid jets and in which the fibre assembly is packed and compressed into a configuration where the individual filament or fibres became folded or bent.

Stuffer box texturing: See **Texturing, stuffer box**.

Stuffer channel: (compression channel). Is used for compressing the piece goods together in a longitudinal direction when milling on a rotary milling machine for rope treatment or in open-width washing machines to relax the fabric.

Stuffer yarn: An extra backing yarn running in the warp direction through a woven pile floor covering.

Stuffers: Extra yarns running in the warp direction through a woven fabric to increase the fabric's strength and weight.

Stumba: Combing silk obtained from the waste of shappe silk; it is quite coarse and is used for filling yarn, coarse knitted fabrics, etc.

S-Twist: See **Yarn Twisting**.

Stylist: Designer who puts together a range of products.

Styboline: Felt made of woollen and linen yarn in France.

Styrene: An unsaturated hydrocarbon, ($C_6H_5-CH=CH_2$), prepared from coal tar. Polystyrene is a colorless, transparent plastic used for molding various articles for insulation, transparent parts, radio parts, etc.

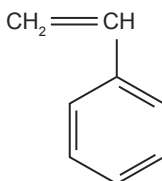

Styryl dyes: The styryl dyes are neutral molecules containing a styryl group $C_6H_5CH=C$, usually in conjugation with an *N,N*-dialkylaminoaryl group. Styryl dyes were once a fairly important group of yellow dyes for a variety of substrates.

Sublimation: The conversion of a solid directly to a gas, for instance, at standard pressure iodine, solid carbon dioxide, and ammonium chloride sublime, without passing through a liquid phase. At certain conditions of external pressure and temperature an equilibrium can be established between the solid phase and vapor phase. Some disperse dyes will sublime. This can make dyed fabric subject to fading due to heating, as from ironing at high temperature. Sublimation printing of synthetic fibres, mostly polyester, is used commercially. Typically, the pattern is printed on paper, then the dried pattern is heat transferred to the fabric. The dye gas penetrates the hot fibre, where it becomes physically trapped as it cools back to solid form. Washfastness is very high. There are now a number of special sublimation inks available for computer printers and others for screen printing, both for making transfers. One t-shirt maker also makes shirts that have a polyester outer layer and a cotton inner layer, also specifically for “digital” transfer printing.

Sublimation printing: A form of transfer printing (q.v.) that uses dyes that sublime readily and have substantivity (q.v.) for the substrate to which they are applied.

Sublimation Fastness: Fastness of a dye or dyeing against sublimation. Usually a property of Disperse dyes which sublimes and stains the adjacent fabric. See **Sublimation**.

Sublistatic® process: A method of applying print designs to fabrics containing manufactured fibres by paper-transfer techniques. Developed by Sublistatic Corp. (Also see Prin Heat Transfer Printing.)

Submerged spin process: Used for dyeing continuous yarn and cross spools with reactive dye substances using the cold residual process. Cross spools are impregnated in a dye bath by a centrifuge. Commercial interest is limited to Space dyeing.

Submerged test: Testing method for water repellent impregnation of textiles (particularly yarn, activity products and knitted fabrics). Technique: weigh textile to be tested, submerge in sieve 10 cm under water for 5 minutes whilst agitating sieve to free trapped air, remove from water, allow to drip for approx. 10 minutes, weigh and ascertain water absorption.

Submerged thermosol process: Follow-on process for (bleaching and) whitening synthetic fibres (also cotton mixtures): stretching process 2–5

min in hot fluorescent brightening liquor in the residence device (immersion accumulator), then squeeze out, dry and thermo fix. When fixing the fibre non-bound or diffused, whitener is thermosol fixed.

Substantivity: The attraction, under the precise conditions of test, between a substrate and a dye (or other substance) where the latter is selectively extracted from the application medium by the substrate. A dye that is substantive will leave the dye bath and be concentrated on the fibre in the bath. Without substantivity, most of the dye would simply remain in solution or dispersion in the bath. Dye substantivity is generally associated with the molecular structure of the dye, and often big molecules have high substantivity, while small molecules have low substantivity. Dye bath conditions, including temperature and additives such as salt influence substantivity. Substantivity is often produced in ways that differ from the final bond of the dye to the fibre. Also see **Affinity**.

Substituent: An atom or group substituted for another in a compound. Often the term is used for groups that have replaced hydrogen in organic compounds. For example, in chlorobenzene (C_6H_5Cl) chlorine can be regarded as a substituent.

Substitute: A cheaper or inferior fibre which takes the place of a more expensive one, as for instance cotton used instead of wool or silk.

Substitution reaction: A reaction in which an atom or group of atoms in an organic molecule is replaced by another atom or group. The substitution of a hydrogen atom in an alkane by a chlorine atom is an example. Substitution reactions fall into three major classes depending upon the nature of the attacking substituent. *Nucleophilic substitution:* the attacking substituent is a nucleophile (i.e. a molecule or ion that can donate electrons). Such reactions are very common with alcohols and halogen compounds, in which the electron-deficient carbon atom attracts the nucleophile and the leaving group readily exists alone. Examples are the hydrolysis of a haloalkane and the chlorination of an alcohol:

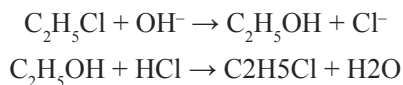

Electrophilic substitution: the attacking substituent is an electrophile (i.e. a molecule or ion that accepts electrons). Such reactions are common in aromatic compounds, in which the electron-rich ring attracts the electrophile. The nitration of benzene in which the electrophile is NO_2^+ is an example:

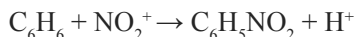

Free-radical substitution: a free radical is the attacking substituent. Such reactions can be used with compounds that are inert to either nucleophiles or electrophiles, for instance the halogenation of an alkane:

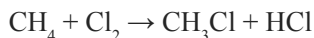

The term 'substitution' is very general and several reactions that can be considered as substitutions are more normally given special names (e.g. esterification, hydrolysis, and nitration). *See also* electrophilic substitution; nucleophilic substitution.

Substrate: Fabric to which coatings or other fabrics are applied. It can be of woven, knit, nonwoven, or weft-insertion construction. Generally, substrate properties are dependent both on fibre type and fabric construction. Usually the fabric is scoured, heat-set, and otherwise finished prior to coating or bonding. Many smooth-surfaced manufactured fibre fabrics require impregnation with a latex prior to coating to ensure adequate adhesion.

Substrate, in effluent treatment: The term used to denote the organic matter or nutrients that are converted during biological treatment or that may be limiting the biological treatment. For example the carbonaceous organic matter in waste water referred to as the substrate that is converted during the biological treatment.

Subtractive, colour chemistry: With reference to colour, removal of colours from light reflected from a surface. A surface that is illuminated by white light and that reflects all visible colours will appear white. The surface can be made to appear some other colour than white by altering it with materials that absorb or subtract colours present in the white light. The subtractive primary colours are designated cyan, magenta and yellow. If a white material is coloured with something that absorbs magenta, for example, then cyan and yellow will be reflected, making the material look what is normally called green. If another material is added that absorbs the cyan component "subtracts" cyan, then only the yellow is reflected, and the material looks yellow. If all colours are subtracted or absorbed, then the material appears black. Dyes used on fabric work according to subtractive principals. In theory, if truly pure cyan, yellow and magenta dyes were available, any other colour could be mixed from them. In practice, there are limitations. Colour theory and practice are complex topics.

Subtractive colour mixing: The subtractive primary colours are cyan, yellow and magenta and when mixed together they subtract from the light producing black. When different pairs of subtractive primaries are mixed, the colours red, green and blue are produced.

Subtractive primaries: Cyan, magenta and yellow. Theoretically, when all three subtractive primaries are combined at 100% on white paper, black is

produced. When these are combined at varying intensities, a gamut of different colours is produced. Combining two primaries at 100% produces an additive primary, either red, green or blue:

100% cyan + 100% magenta = blue

100% cyan + 100% yellow = green

100% magenta + 100% yellow = red

Suction-drum drier: Sieve-drum drier. Hot-air dryer for loose material, tow (fibre manufacturers), hank yarn, cloth and knitted fabrics. The material is sucked in through the perforated, rotating drum by airflow, soaked heavily and then dried.

Suede: The correct term is Suede Leather, because it is usually calfskin treated on the inside to give a napped or sueded finish. It is smooth and attractive and can be dyed in a variety of fashion colours. Readily available for sewing and can be made into a variety of garments.

Suede cloth: See **Suede, Suede Fabric.**

Suede Fabric: There is a wide variety of simulated suede or suede fabric available. Most types are fairly expensive, although advantage over real suede is that they do not take on permanent creases or show wear easily, and most of them are washable. The method of manufacture and fibre content vary. It is suitable for dresses, jackets for men and women, skirts, children's clothes, sports and leisure outfits.

Suede finish: See **Suede fabric.**

Suède leather: (1) Roughened Leather and is also called genuine suède leather (for example leather made from deer). It is either polished grain (e.g. Nubuk) or polished velour (e.g. lamb, sheep, calfskin, cow velour). Imitation suede leather Imitation suede. (2) (suède) Leather with a velvety rough or fluffy surface. The flesh side is cut and worn on the outside (for example Danish, suède leather). The grainy side is smoothed to obtain a special soft velvety texture (e.g. Nubuk Leather).

Suede look: "Swedish Leather" with suède characteristics, for example Duvetine and rough suede jeans material with flocked variants.

Suedette: See **Velour.** This is a five or eight stem reinforced satin material. A velvety effect is obtained by strongly roughing the right side of the fabric. Another name for this fabric is Duvetine.

Suedine: This is an imitation leather fabric with suède characteristics.

Sueding: (emerizing). This is performed on the surfaces of cloth or knitted fabrics. During emerizing the fabric is covered by a thin pile that does not

damage the machine or the structure of the fabric. The effect is dependent on the structure of the yarn and the surface.

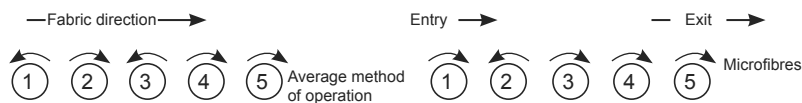

Optimum emerizing effects; direction of emerizing roller rotation relative to fabric direction

The shorter and thinner the fibre in the yarn, the lighter and easier it is to obtain the pile. The initial emerizing refining materials are also influenced by this.

Suèding machines: (emerizing machines). Material with suède leather characteristics is produced on the emerizing machine by the emerizing rollers which split and emerize the fibre. A carrier roller ensures the cloth is guided correctly under constant tension. The emery rollers which are wrapped in a spiral with emery paper are driven by a high performance motor and can be rotated (generally 950, 1200 or 1600 rpm), as desired, with or against the passage of fabric.

Suedoise: French serge, made with 8 harnesses and 4 picks in a repeat.

Suedyne: See **Velour**.

Suessen Heat Setting: Process using dry heat to set twisted yarn.

Suffolk Lace: English bobbin lace of plain patterns, the design usually outlined with a thick thread.

Sugar: (saccharide) One of a class of sweet-tasting simple carbohydrates. Sugars have molecules consisting of a chain of carbon atoms with $-OH$ groups attached, and either an aldehyde or ketone group. They can exist in a chain form or in a ring formed by reaction of the ketone or aldehyde group with an $-OH$ group to form a cyclic hemiacetal. Monosaccharides are simple sugars that cannot be hydrolyzed to sugars with fewer carbon atoms. Two or more monosaccharide units can be linked in disaccharides, trisaccharides, etc., by a glycosidic link. Monosaccharides are also classified according to the number of carbon atoms: a pentose has five carbon atoms and a hexose six. Monosaccharides with aldehyde groups are aldoses; those with ketone groups are ketoses. Thus, an aldohexose is a hexose with an aldehyde group; a ketopentose is a pentose with a ketone group, etc. The ring forms of monosaccharides are derived by reaction of the aldehyde or ketone group with one of the carbons at the other end of the chain. It is possible to have a six-membered (pyranose) ring or a five-membered (furanose) ring.

Sugar fibres: Cuban. Raw material fibre from the waste from sugar production.

Suint: Mainly from Wool fat and Wool grease suint (consists of between 8 and 58%).

Suint scouring: In this process the dusted raw wool is steeped in water at 16°C and then the liquor is withdrawn and clarified by sedimentation or centrifuging. The pH of the suint liquor is between 5.5 to 8.8. For removal of wax the suint liquor should be heated at 60°C when wax is emulsified. The material is then rinsed, washed with soap and finally rinsed in the subsequent bowl.

Suiting lace: The term is used to describe any type of firm lace which would be suitable and durable for formal garments such as jackets and skirts. The yarns are usually thick and matt and firm such as cotton and viscose. The motifs or designs are deliberately close together to provide stability and to prevent fabric from being too see through.

Sujini: Embroidered quilt made by women of Bihar India. See **Kanthas**.

Sulfamic acid and ammonium: Combinations of these compounds also function as non-durable flame retardants.

Sulfur fibre: A manufactured fibre in which the fibre-forming substance is a long chain, synthetic polysulfide in which at least 85% of the sulfide (-S-) linkages are attached to two aromatic rings (FTC definition). The raw material is polyphenylene sulfide which is melt spun and processed into staple fibres. These are high performance fibres with excellent resistance to strong chemicals and high temperature. They show excellent strength retention in harsh environments; are flame retardant; and are non-conducting. They find use in high-temperature filter fabrics, electrical insulation, coal-fired boiler bag houses, papermaker's felt, and highperformance composites.

Sulphate Pulp: Kraft pulp.

Sulphates: A salt or ester of sulphuric(VI) acid. Organic sulphates have the formula R_2SO_4 , where R is an organic group. Sulphate salts contain the ion SO_4^{2-} .

Sulphites: Salts from the sulphuric acids (H_2SO_4 ; Sulphur oxyacids). They are either acid salts (e.g. Sodium bisulphite) or normal salts (Sodium sulphite). Only alkali salts are soluble, and as a result have an alkaline hydrolysis reaction. Usage: they are reducers, bleachers and separators.

Sulfonated: A term describing a material that has been reacted with sulfonic acid, usually to impart solubility, dyeability with cationic dyes, or other properties.

Sulfonates: A salt or ester of a sulphonic acid.

Sulphonation: A reaction used in the dyes chemistry. By sulfonation is meant the introduction of an $\text{—SO}_3\text{H}$ group into a molecule. The operation results in a product which is usually very soluble in water, either in the form of the free sulphonic acid, as is often the case, or in the form of its salts. Of the salts, the inexpensive sodium salt is usually encountered. Sulfonation is effected: (a) With ordinary concentrated sulfuric acid (66°Be); (b) With 100 per cent sulfuric acid; (c) With fuming sulfuric acid (oleum), with the concentration of SO_3 varying from 5 to 70 per cent; (d) With chlorosulfonic acid, with or without diluent; or (e) by “baking” (dry heating) the acid sulphate of an amine, often in vacuum.

Sulphonation, degree of: A percentage of the organic bonded sulphuric acid and SO_3 in Fatty alcohol sulphates and similar sulphates. Fats are water-soluble during contact with the Sulphonic (acid) group.

Sulphonic acid: Any acid containing the sulfonic group, (SO_3H).

Sulphonyldiethanol: Used as a crosslinking agent for cotton. It can be made by the reaction of di-vinyl sulphone with alkali.



Sulphur dye: a class of dyes made by reacting sulfur with organic compounds; most are of unknown chemical structure Sulfur dyes are insoluble in water, and must be converted to a soluble form for application. The process is a quite similar to that used for *vat dyes*. Sulfur dyes are typically inexpensive, but dull in colour. They generally have good washfastness, but are sensitive to bleaches. Sulfur dyes on fabric, particularly some blacks, may decompose under warm, humid conditions, forming an acid. This can cause *tendering* of cellulose fibres, but can generally be prevented by making the finished fabric slightly alkaline. Sulfur dye is often used commercially to produce a good black at low cost on cellulosic fabrics.

Sulphamic acid Sufamic acid: $\text{NH}_2\text{SO}_3\text{H}$ Sulfamic acid, applied to wool typically by printing, followed by baking then steaming, fixes to the wool much like an acid dye. It is colorless and prevents the treated wool from taking up other acid dye, so it is an effective.

Sulphobetaines: Used for high grade finishing. Examples include Triethylsulphateamine, disodium salt.

Sulphonated fatty acids: These products are used in textile as surfactants. They are made by reaction of fatty acids and sulphuric acids in so doing, finally react (with the efflux of water) with a CH_2 -group and which explains, with

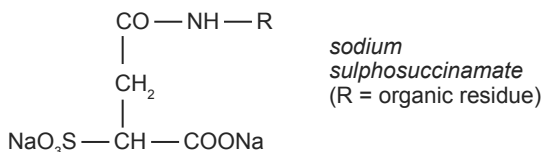

They are characterized by the presence of two entirely different ionisable groups (sulphonic acid group and carboxyl group) which differentiates them from other surface active agents. The consequent bifunctionality in interaction with the amide group yields specific characteristics which predestine them for use in emulsion systems. Thus certain sulphosuccinamates are used alone or in mixtures with e.g. potassium oleate sulphate or sodium lauryl sulphate as an emulsifier for latex compounds, as well as as an emulsifying and foaming additive in the manufacture of foamed carpet backing coatings.

Sulphoxylate, Sodium formaldehyde: ($\text{NaHSO}_2 \cdot \text{CH}_2\text{O} \cdot 2\text{H}_2\text{O}$) mostly 98–99%, stable (if protected against moisture and heat), soluble in cold water; used as: deoxidant in cloth printing (vat dyes), discharging of direct and naphthol dyeings.

Sulphoxylates, Zinc formaldehyde: (a) Primary salt $[\text{Zn}(\text{SO}_2\text{CH}_2\text{OH})_2]$, water-soluble; used for: stripping of dyeings, deoxidant in vat-dye printing, discharge printing of acetate fibres, etc. (b) Secondary salt $[\text{Zn}(\text{SO}_2\text{CH}_2\text{O})]$, not soluble in water, soluble in ethanoic acid or formic acid bath; used for: stripping of dyeings, discharge agent.

Sulphoxylate, Zinc acetate aldehyde: oxyethane sulphinic acid zinc: $[\text{ZnSO}_2(\text{CH}_2\text{OH})_2]$, difficult to dissolve in water, used for: stripping.

Sulphoxylate, Calcium formaldehyde: deoxidant for printing with vat dyes.

Sulphur dyeing: Dyeing with sulphur dyes. Dyeing is very similar to vat dyes, i.e. dye is applied in the reduced form on the substrate and oxidized to form the original insoluble form on the fibre. Na_2S is usually employed as the reducing agent in the presence of sodium carbonate. There are mainly two types of sulphur dyes – Normal and modified types. Normal types should be boiled with 1 to 3 times the amount of sodium sulphide. This solution must be filtered before being added to the dye bath. Modified types, on the other hand, are water-soluble or can be diluted with water and they can be prereduced or otherwise. Method of application as per manufacturers directions. The affinity of these solutions are very less and hence taken up by the substrate slowly. Material can be padded and steamed also. Oxidation is done after rinsing with hydrogen peroxide. It can be oxidized by dichromate, hypochlorites etc which is not well practiced now due to various reasons.

Sulphuric acid: H_2SO_4 ; A very potent inorganic (“mineral”) acid; a strong acid Sulfuric acid is used in some preparation and dyeing process, most often with wool. Concentrated acid will absorb water very rapidly, releasing heat in the process. Skin burns are caused by both this heating and by corrosive action, and can happen within seconds. See comments under acid regarding mixing. Sodium bisulfate (not bisulfite) can sometimes be used as an alternative.

Sultanabad: Medium and large size Persian rugs made with thick pile. The design consists of floral patterns in brilliant blue, red and green colours.

Sumach: Leaves and twigs of several species of Rhus, containing tannic acid. It is sold in the form of crushed leaves or as a powder (15–20% tannin).

Summer Silk: Same as **Louisine**.

Suningshow: Soft silk serge in solid colours, made in China; is about 32 inches wide.

Sunn: A bast fibre obtained from the plant *Crotalaria juncea*, south Asian, water-retted, coarse and hard. Used for cords and ropes.

Super Light Weight: Term used to describe a fabric used in outerwear, which allows for a minimum pack volume and weight. These lightweight, packable garments offer the most versatile weather protection. Some of these fabrics have a protection layer on the membrane, which provides durability. This means that the garments made from the extra lightweight fabrics need no separate lining.

Super Micro Fibres: The so-called supermicrofibres are finer than Microfibres by a power of ten; supermicrofibres are obtained by dissolving out the polyester “islands” in “islands in the sea” technology. They are generally of less than 0.1 detex. In island in the sea technology composite fibres are spun with many super microsize (less than 0.1 dtex) inside another polymer which can be later on dissolved and super microfibres can be separated. See fig. below.

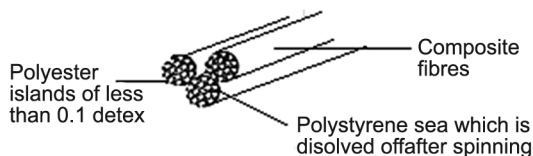

Superabsorbent: A material that can absorb many times the amount of liquid ordinarily absorbed by cellulosic materials such as wood pulp, cotton, and rayon. Absorbent compounds such as highly absorbent polyacrylate powders, can be used in the hygiene sector for the absorption of wetness which occurs suddenly.

Superba Heat Setting: Process using steam and pressure to set twisted yarn.

Supercop: (1) A wooden or plastic conical base on which weft is wound for use in a shuttle loom. (2) A weft package produced by winding a yarn on to the base defined above.

Superdull fibre: Superdull fibres are fibres with 1-3% titanium dioxide, which is used to dullen the fibre.

Superfine wool: The finest, most expensive wools used for mens suitings and luxury knitwear. Mainly from Australian Saxon Merino sheep.

Superimposed yarn layer: Bonded yarn fabrics which are arranged randomly or deliberately.

Supermicrofibres: The so-called supermicrofibres are finer than Microfibres by a power of ten; supermicrofibres are obtained by dissolving out the polyester "islands" in "islands in the sea" technology.

Supermilling: A class of acid dye Supermilling acid dyes offer moderate brightness and good to very good washfastness, but have poor to fair *leveling* tendency. Their leveling characteristics mean that extra care is required in the process to produce level results. There is no clear distinction between milling and supermilling acid dyes. These dyes are used for wool and work well on polyamide (nylon).

Supernatant: Denoting a clear liquid that lies above a sediment or a precipitate.

Superpolyamide fibres: Carothers (the inventor of the polyamide 6.6 fibre), used this name to denote all fibre-forming polyamides with a molecular weight over 10,000.

Superwash: A quality term defined by the International Wool Secretariat (IWS) for wool articles which have been finished to be resistant to machine washing.

Superwash wool: See **Super wash**.

Supewash process: See **Superwash process**.

Suples: Silk yarn dyed with only part of the gum removed.

Supported needle felt: A needled felt that is composed entirely of fibres physically interlocked and reoriented in combination with interlay, scrim, or foundation of knitted, stitched, bonded, or extruded structure.

Supukwenkin: Silk fabric similar to lustring; made in China; used for scarfs.

Surah: (1) Thread dyed warp of organzine and weft of tram with 45° diagonal weave structure. Even sided tewill with srtrongly marked slant-ribbed effect. A twilled silk similar to serge; first made in Surat, India.

(2) A soft twill fabric made from filament yarns, including silk, polyester acetate, triacetate. It is always printed, shiny fabric. It is not hard wearing, and tends to develop slippage at seams and points of strain, and creases easily. Used for loose dresses, blouses, scarves, ties and as a lining fabric.

Surah de Laine: Fine, twilled, soft dress goods, made of silk and wool.

Surcot: Women's or men's over garment, usually sleeveless and unbelted, often trimmed with fur.

Surface activity: Surface activity of a substance is generally related to the balance between hydrophilic and hydrophobic portions of its molecule. For example, among anionic surfactants C8-C12 alkyl hydrophobes tend to be predominantly wetting agents, while the C12-C15 homologues exhibit better detergency and emulsifying properties. They have different levels of surface activity due to the property of the molecules described above.

Surface active agent: See **Surfactant**.

Surface charge: The electrical charge on the surface of a substance.

Surface contour: Divergence of a surface from planeness rough (high) to slippery (low).

Surface energy: (1) The free energy of the surfaces at an interface that arises because of differences in the tendencies of each phase to attract its own molecules. (2) The work that would be required to increase the surface area of a liquid by one unit area.

Surface finishing: Finishing, mechanical or chemical which is made on the surface of a fabric to enhance the quality, appearance etc. In pretreatment, special surface finishing steps such as singeing, emerizing, brushing or roughening can be applied to the dry or wet goods, in order to shape the quality. Raising, shearing peaching, polishing, sanding are other finishes which are applied at various stages of processing which can be considered as the surface finishes

Surface friction: Resistance to slipping offered by surface harsh (high) to slippery (low).

Surface print: Prints with a greater colour intensity resulting from the concentration of dye printed onto the fibre surface. This effect is achieved by using suitable thickeners, which should be in combination with semi-emulsions if reactive dyes are used. For any other type of dye, thickener combinations containing starch should be used.

Surface printing machine: The pattern is printed by means of raised relief-type printing elements. In contrast to Roller printing machines, the surface

printing machine can print all wovens using the same rollers. The only difference is that print paste application to the print rollers is varied with a paste application device.

Surface reflectance: A small portion of the incident light (less than 2% with textile materials and paper) is immediately reflected from the surface due to different optical material/air density. This portion is termed surface reflectance or residual reflectance.

Surface tension: Surface tension is defined as the interfacial tension between a liquid and its vapor. Intermolecular forces acting on the molecules at the free surface of a liquid tend to minimize the surface area of the liquid and give the surface properties similar to those of an elastic skin under tension. When two dissimilar liquids make contact, these intermolecular forces will cause the shape of the interface to change until the potential energy of the entire molecular system is at a minimum. A very simple method of measuring surface tensions is with a du Noy tensiometer. This technique measures the force necessary to pull a platinum ring away from a liquid. For pure water, the force is 72 dynes/cm.

Surface water absorption, in a fabric: The process of removing liquid water from a surface such as human skin, dishes, furniture, car etc.

Surfactant: The word surfactant is coined from the expression “surface active agent”. As the phrase implies, a surfactant molecule possesses surface activity, a property associated with the chemical structure of the molecule. The characteristic feature of a surfactant molecule is its two ends attached by a covalent bond. The two ends have diametrically opposed polarities. The non-polar end is lyophilic (strongly attracted to organic molecules) while the strongly polar end is lyophobic (having little attraction for organic molecules) yet strongly hydrophilic (water loving). Duality of polarity causes the molecule to align itself with respect to the polar nature of the surfaces it contacts. When used in association with dyeing, this term almost invariably refers to a synthetic detergent. Detergents operate at the surface between a solvent (water) and some material that is to be removed from where it is, and made to enter solution or suspension in the solvent. One end of the surfactant molecule is hydrophilic (“likes” water, and the other is hydrophobic (“fears” or water; sometimes lipophilic - oil loving). Surfactants can be synthesized to have specific properties by varying the structure of the hydrophilic and hydrophobic ends. Surfactants are used to *scour* fibres or fabric, act as wetting agents in dyeing, as retarders in dyeing, and to help remove unfixed dye after dyeing. They may be classified as anionic, non-ionic or cationic. There are even types that can behave as anionic or cationic, depending on conditions.

Some fabric softeners are surfactants. There is a vast array of surfactants on the market.

Suri fibre: Fine animal hair originating from a species of South American camel. From a quality point of view, it is the best type of Alpaca fibre, having an even colour shade and even linear density (approx. 25 mm, about 90–110 scales per mm).

Surikome printing: Ancient Japanese technique, a multi-coloured version of Kasuri dyeing.

Surinam: Variety of raw cotton from Guyana; the fiber is white or yellowish, lustrous and strong.

Surtout: An overcoat cut in the style of a frock coat.

Suspended growth process, in ETP: Biological treatment process in which the microorganisms responsible for the conversion of organic matter or other constituents in the waste water to gases and cell tissue are maintained in a suspended form within the liquid.

Suspended solids, in waste water: Solids that are held in the waste water, which are not soluble. It can lead to the development of sludge deposits and anaerobic conditions when untreated waste water is discharged in the aquatic environment.

Suspended web: See **Brace web**.

Suspoemulsion: A mixture of anionic and non-ionogenic emulsifiers or anionic dispersants, with specific stabilizers and de-foamers. With a suspoemulsion, it is possible to combine biocides with varying physical and chemical properties, because it has a mixed structure.

Sutherland: A Highland tartan, composed as follows: dark green stripe, split in the center by a very narrow black stripe; black stripe, half as wide as the green; dark blue stripe, as wide as the green, split by a pair of very narrow black stripes, placed near the edges and spaced from each other and from the edge their own width; green stripe, width and split as above; dark blue stripe, as wide as above, split in the center by a single pair of very narrow, black stripes, spaced their own width.

Sutwan: Various Chinese piece dyed silk satins.

Suzeni: Embroidery Persian needlework, consisting of couched silk or gold threads.

SVCC: Schweizerischer Verein der Chemiker-Coloristen (Swiss Association of Chemical Colorists).

Swansdown: A narrow fuzzy decoration originally made from the downy breast feathers of the swan, but now more often made from synthetic fibre. Used to trim nightwear, evening gowns.

Swatch: A piece of fabric used as a representative sample of any fabric.

Sweated wool: Skin wool treated using the sweating process (sweating: controlled rotting process, the oldest biological method of dewooling). See **Mazametwool**.

Sweating: The process of removing wool from the skin, by exposing the skins, which are first soaked in water, to high temperature.

Sweatshirt Fabric: Acrylic or cotton knit fabric with a bumpy fleecy back in a variety of plain colours and striped designs. The yarns used are often marled. Some fabrics are quite thin; all stretch easily and lose their shape. Not hard wearing. Used for sports and leisure clothes.

Swedish lace: Swedish lace is said to be very very old. Fragments of cloth woven in this structure was found in the marshes in Sweden dating from the time of the Vikings. These structures are effected by the distortion of warps and wefts. The distortion of the warp and weft in this handsome structure results from the interlacing some of the threads from time to time so that the ends/picks slide to gether. The effect is emphasized by the use of smooth, plain, and particularly hard-twisted yarns and by washing the fabric. The manipulation is involved in the washing process allows the threads to come to the most stable configuration: Threads not held apart come together, It happens every time. Soft woollen yarns may be used to make warm and cuddly shawls, scarves and blankets. The structure of the cloth is somewhat blurred when those yarns are used, but the results are still lovely. Swedish lace needs four shafts. In a typical construction the ends carried on shafts 1 and 4 weaves plain weave everywhere.

Swelling: In textile usage, expanding of a fibre caused by the influence of a solvent or chemical agent. A property often used to facilitate dyeing.

Swelling agent in dyeing: See **Carrier**.

Swelling agent in printing: The absorbency of print pastes is frequently limited in regenerated cellulose fibres, and for this reason swelling agents are added to the print paste.

Swelling shrinkage: Results from the swelling and de-swelling of the constituent fibres of a fabric due to the absorption and desorption of water.

Swift: is an expandable cage that turns on a center rod to hold a skein of yarn so that it can be wound into a ball or directly onto the warping board.

Swim wear: Textile garments intended for wear in fresh, chlorinated or fresh water.

Swimming roller: (S roller), roller construction where the roller floats on a hydraulic cushion. The operation of the hydraulic chamber and the bearing pressure can deflect every S roller positively or negatively, or allow the flexible line of a conventional roller to be followed whilst applying even pressure. For many processes it is sufficient to operate using only one S roller in the padder or drying system. The situation is different in processes with a rapid reaction, such as before a hot flue or steamer, and during drying. Here the most important factor, as before, is that articles are smooth and identical on both sides. These requirements apply to a dye padder with two S rollers arranged horizontally.

Swiss applique: A very light, sheer cotton fabric, having small, separate (not continuous) patterns printed in only one colour. These patterns are raised and consist of finely ground cotton fibres which are stuck to the cloth with glue.

Swiss: Brussels Curtains with patterns outlined in chainstitch by the tambour machine.

Swiss Embroidery: Washable machine and hand embroidery made, mostly white over white, in Switzerland.

Swivel Weave: The Swivel weave differs from lappet in that designs are produced by extra filling yarns. Separate shuttles are placed at each point where the design has to be made. The shed is formed by the pattern, where the shuttle carries the yarn through the shed, the distance of the pattern. The extra filling floats on the back of the fabric, the long floats is cut away after weaving is completed. Example: **Silk sarees.**

Swiss mull: Very thin, bleached and dressed cotton dress goods.

Swiss muslin: Fine, thin cotton muslin, made in Switzerland; it is plain or dotted.

Swissing: Process of calendering bleached muslins between hot rollers.

Swivel Fabrics: Trade term for a variety of silk or cotton fabrics, having relatively heavy Jacquard figures or spots on a very light ground. They are used for dresses, waists, overdresses, etc. The dots or figures are either woven into the cloth with an extra filling, floating on the back of the cloth between the different patterns, and shorn away in the finishing process, or made as lappet work the extra thread forming a trailing design.

Swivel weaving: Consists of introducing a number of small shuttles besides the fly shuttle, which produce small designs on the foundation. There is one

shuttle for each figure, and they do not leave long floats. The result is similar to embroidery.

Swizzing calendars: Swizzing is a British term used to denote that the fabric runs through all of the nips at the same surface speed as the rolls. Swizzing calendars usually consist of seven to ten bowls and are run at ambient temperatures. The fabric effect is closed interstices, a smooth appearance and gloss without the high glaze characteristic of a friction calendar.

Syddo: A fairly stiff but flexible woollen; used for coat fronts in lieu of haircloth.

Symmetrical straight herringbone: See **Herringbone, symmetrical or pointed straight**.

Symmetrical 2/2 vertical herringbone: When the twill is turned 90 degrees to become a symmetrical 2/2 vertical herringbone, three ends floats appear every fourth pick. This twill can be woven on this straight threading; it cannot be woven on a straight threading because a straight threading allows the twill rib to move only in one direction across the weft as a regular 2/2 twill cannot be woven on a point threading.

Synchronisation: (Gk.: synchronos = at the same time), making two processes or machines operate simultaneously.

Syndiotactic polymer: A polymer structure in which the atoms that are not part of the backbone chain are distributed in a symmetrical and recurring manner above and below the backbone chain when the latter is in a single plane. Also see Atactic polymer, Isotactic polymer, Tactic polymer.

Syneresis: (Gk.), contraction; term applying to selfdrying in foaming; Foam performance evaluation.

Synergistic: (Gk.), concurrent influence causing increased interaction, i.e. more than the additive effect of a combination at a specific ratio, e.g. in the case of well-proportioned mixtures of surface-active substances. See Synergistic effect.

Synergistic effect: Effect that causes a combination of two surfactants for example (or other substances) to achieve a specific effect even at a low concentration within certain interactively defined concentration limits in a solution. The concentration is lower than the mix-ratio concentration that corresponds with the linear dependency for this effect. Any substances involved in this effect can also be compounds/mixes.

Syntan: Synthetic tanning agent There are many syntans, and many are proprietary mixtures of chemicals. They are sometimes used as postdyeing treatments for wool or nylon to increase washfastness.

Synthetic dyes: This term can be used to mean man-made dyes (also covers the old-fashioned aniline and tar dyes). They are manufactured using chemical synthesis. As opposed to Natural dyes, which are obtained from plants or animals, synthetic Dyestuff is manufactured on the basis of a chemical reaction involving basic material that was originally obtained from mineral oil (formerly coal).

Synthetic felt: This is a nonwoven fabric, fairly thin but with an interesting texture. It dyes well and is available in a range of bright clear colours. It has no grain but does not stretch. Used for decorations, appliqué etc.

Synthetic fibre: (synthetics) Fibres spun using various different processes from high-molecule, chainstructured substances manufactured synthetically, composed of low-molecule modules of the following main synthetic fibre groups: (a) Polymer fibres, e.g. polyacrylonitrile, polyethylene, polyvinyl chloride. (b) Polycondensation fibres, e.g. polyester, polyamide. (c) Addition polymer fibres, e.g. polyurethane.

Synthetic filaments: Dated term for Elementary filament made from synthetic fibres, Filament; Capillaries; Fibrils, single end threads; but also for Filament yarn.

Synthetic filament yarn: Filament yarn made from synthetic fibres.

Synthetic finishing Agents: Synthetic colloids.

Synthetic leather: (synthetic suede), term for Imitation suede; Artificial leather banned on the grounds that the term is anti-competitive.

Synthetic monofilament: Monofilament made of synthetic fibre with $\text{Ø} > 0.1 \text{ mm}$.

Synthetic resins: synthetic resins are substances and preparations that can react primarily with themselves in coating and impregnation, or steeping, such as

- melamine resins,
- urea/formaldehyde resins,
- phenol resins,
- polyester resins.

Monomers that are not able to react with themselves are not categorized as synthetic resins. Use: auxiliaries in all aspects of textile finishing, for resin finishing, wet crease-resistant, hydrophobic, slip-resistant and antisludging finishes. Permanent handle, stiffening, weighting, backcoating finishes; hat stiffening; permanent embossing, Schreiner, chintz effects; sizing; coating; laminating; permanent impregnation; nonwoven fleece impregnation; flocking adhesive; binding agents for pigment printing, etc.

Synthetic rubber: Typical examples are butadiene polymers, chloroprene polymers or mixed polymers (Polyblends), e.g. made from ethylenepropylene diene, isobutene-isoprene, butadiene-acrylonitrile, butadiene-styrene or sulphochlorinated polyethylene. : Butadiene-acrylonitrile-rubber; Styrene-butadiene rubber; Epichlorohydrine rubber; Isoprene; Polyester elastomers; Polyurethane rubber; Silicone rubber.

Synthetic suede: Synthetic velours.

Synthetic thickener: Weakly crosslinked copolymers of oleofinic monomers containing carboxyl groups with a high molecular weight, which act as polyanionic bodies in the range of pH 7–10 as thickeners with similar rheological properties to an Emulsion thickener.

Synthetic velour: A term covering the following: synthetic leather knit (synthetic leather), imitation suede, imitation leather, microfibre whirled pile, synthetic leather, synthetic suede, suede imitation. “Leather imitations and synthetic leather” is the only generic term considered by certain standards.

Synthetic washing agents: Syndets, i.e. washing agents manufactured from synthetic detergents.

Synthetic waxes: (artificial wax, man-made wax), used as additives in sizing, finishing, waterproofing, etc. Polyethylene glycols (solid), Montan wax or paraffin oxidation products (Fatty acids, synthesis of) in the form of esterized (and natural) fatty acids and alcohols, with or without further additives, also as soft and hard waxes with widely varying melting points (approx. 70–100°C) are used as synthetic waxes.

Synthetics: This applies to (1) Synthetic fibres. (2) Synthetic detergents.

Synthetic detergents: See **Detergents**.

Synthetic weighting: The monomer used for synthetic weighting is often derived from acrylic or methacrylic acid. The silk weighting with acrylonitrile and methymethacrylate has been studied and described thoroughly; in this process, starters are formed by a redox system based on iron salts (Fe⁺⁺) and hydrogen peroxide, persulphates and other substances.

T

T: Abbreviation for temperature.

TA: Triacetate fibres.

Talc: (French chalk) An extremely soft greenish or white mineral, a hydrous silicate of magnesium ($Mg_3Si_4O_{10}(OH)_2$). Purified it is sold as talcum powder. It is also used as a lubricant, an electrical insulator, a filler (in paint, rubber, and paper) and an ingredient of some ceramics.

T.S.P (trisodium phosphate(V)): (sodium orthophosphate; Na_3PO_4) A white solid prepared by adding sodium hydroxide to disodium hydrogen phosphate. On evaporation white hexagonal crystals of the dodecahydrate ($Na_3PO_4 \cdot 12H_2O$) may be obtained. These crystals do not effloresce or deliquesce. They dissolve readily in water to produce alkaline solutions owing to salt hydrolysis. Trisodium phosphate is used as a water softener.

Tab, in garment making: A bagged out piece of fabric that is buttoned or studded into place. In can be used on pockets and fastenings or to control fullness.

Tabard: Men's knee or ankle length closed outer robe, draped in many folds, usually unbelted, used ancient times.

Tabaret: Stout, fine silk drapery fabric with alternate stripes of satin and moire in different colours.

Tabbinet: (1) Fine drapery poplin of silk warp and wool filling with moire finish; (2) Also a thin moire taffeta lining.

Tabby: (1) British equivalent of moire; (2) A thick and coarse taffeta or worsted fabric with moire finish; (3) Cotton velvet, made with weft pile and plain ground.

Tabby sample, in tyre cord: The section of the tyre cord fabric between two tabbies that have been woven separately with a distance of 0.5-1.0 m.(18-36 in.) between them.

Tabby, in tyre cord: A short length of plain weave fabric normally woven at each end of a roll of tyre cord fabric for the purpose of supporting and holding the cords in proper position with respect to each other.

Table linen: Fabric used on dining table like Table cloth, napkin etc. It can be white, plain dyed, printed or even with designs.

Table printing: Flat screen printing. High-quality, multi-coloured prints, e.g. in small runs on silk (e.g. scarves), are printed on tables with a moving film printing carriage.

Table raising/polishing/shearing machine: Raises, polishes and shears in a single run. Both sides of the material can also be processed in a single run without the use of a turning device (back-to-back). An electrically-heated polishing cylinder with beaters ensures lustre. The shearing table can be replaced by a roller for heavily-coated or reverse-side-coated articles for example.

Tablet weaving: Thin Persian knotted carpets with short, smooth woollen tufting. Precise, richly decorated, fine patterns in light colour on background colours of sand, red, matt blue and natural white. Also produced as medallion and hunting carpets. 220,000–250,000 Persian knots per square metre.

Tabriz Rugs: Usually large size Persian rugs with cotton warp; the short and very close wool pile is tied in Ghiordes knot. The favorite design consists of a large center medallion with curved outlines and fine floral and animal patterns. Often several small medallions are used with inscriptions.

Tachometer: Revolution (speed) counter for measuring revolutions of machine shafts, rollers, drums etc. Produced as tachometer for measuring number of revolutions per minute and as an automatic counter for any other period of time. Available in various versions for manual use (checks), fixed installation (works checking of pieces or meter count), the latter also provided with electrical contacts, and registration unit etc. (Oscilloscope).

Tack: Condition of adhesive when it wets the surface sufficiently to form a bond.

Tack, for rubber and rubber compounds: A property that causes two layers of these materials, when pressed together, to adhere at the area of contact.

Tack, in testing rubber coated cords: The force required to separate two identical test specimens under controlled pressure and dwell time.

Tack, in glass tyre cord: The force requires to separate two identical test specimens under controlled pressure and dwell time.

Tack tear: The measurement of the resistance of a coated fabric to tearing under conditions simulating an installation that has been tacked in place.

Tackiness: The property of being sticky or adhesive.

TAED combining with H_2O_2 . As per acetic acid is an unstable compound it disintegrates immediately:

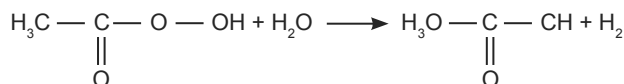

Thus in the lower temperature range TAED produces a significant bleaching effect in the washing bath which at 60°C corresponds virtually in terms of performance to the bleaching effect achieved by perborate at boiling point. The TAED-Perborate bleaching system kills off microbe germs at 40°C and therefore produces hygienic washing results.

Taffet: Taffeta.

Taffeta: A smooth plain weave fabric made from even from yarns of light or medium weight, usually from shiny filament fibres which give the fabric sheen. Taffeta is characteristically crisp and is usually plain coloured but can be printed. Originally a silk fabric but now more likely to be composed of acetate, triacetate, nylon or blends of these. Made in plain or tabby weave, the

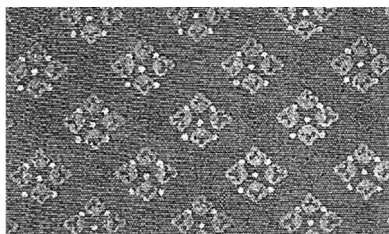

textures range from 60×50 to 200×60 , will always have more ends than picks per inch. One all rayon taffeta can be made of 150 denier warp and weft with texture of 70×46 . Another construction may be 90×60 with 100 denier rayon in the warp and 150 denier rayon in the weft. It is not hard-wearing, hence used mainly for evening wear stiff petticoats, lampshades and drapes, and small items such as cummerbunds, artificial flowers, umbrellas, evening bags, stage costumes and linings.

Taffeta (Silk): Organzine warp (possibly slightly weighted degummed), fabric has a papery handle, with typical rustling. As a rule it is woven with dyed yarns, as further treatments especially at high temperature may cause the fabric to lose its characteristics. In some cases these fabrics are very crease prone.

Taffeta, Faille: Made with a crosswise rib weave. Has a distinct rib effect and is usually quite heavy and firm. Paper Taffeta Plain weave, very light in

weight and treated to give a crisp, paper-like finish. Shot Taffeta Usually plain weave, woven with one colour in the warp and another colour in the filling, which gives the fabric an iridescent look. If fabric is moved in the light this colour changes. Silk version of chambray.

Taffeta Flannel: A lightweight, unshrinkable wool fabric, made in plain weave with coloured stripes and checks; used for sporting shirts.

Taffeta Prismatique: Lustrous, French all-silk taffeta. The warp is coloured in the various shades of the rainbow. The filling is white.

Taffeta, Tissue: Plain weave, very light weight and transparent. Warp-print Taffeta, usually a plain weave, the warp yarns are printed before the filling is inserted. The fabric has a very fuzzy design when design is distorted as fabric is woven.

Taffeta Weave: See **Plain Weave:** Plain weave in silk ware. This is the simplest and oldest method of interlacing. The odd numbers of warp-threads cross the even numbers after every pick; hence of two warp-threads one will always go over the first pick and under the second, and the other end under the first and over the second pick. Taffeta cloth, therefore, has the same appearance on both sides, and in cotton and wool weaving this weave is technically—and properly indeed—called the Plain Weave. It has the smallest repeat, 2 warp-threads and 2 picks, and the exchanging of warp and filling is the most frequent possible. The cloth thus produced is firmer and stronger than that obtained with any other weave.

Taffetine: Plain woven, lightweight lining, made with closely placed organzine warp and coarser cotton, linen or silk filling. It is slightly stiffened.

Tafta: Persian plain woven, rich silk fabric, made of hard spun, ply yarn.

Tag Locks: Large locks of britch wool clotted with dung and dirt.

Tags: Broken or dung-covered wool and other wastes that are swept from the floor of shearing areas.

Tagging: The practice of cutting the dung locks off sheep. Usually this operation is done immediately prior to shearing, and it may be done prior to lambing.

Tahiti: Cotton of the Sea Island type, the staple is good, silky, but irregular in length; contains a large percentage of unripe fibre.

Tahkli: A small, metal-whorl supported spindle.

Tahuari: Native Peruvian name for a thin, fibrous bast of the Couratari tree; used for clothing, blankets, etc.

Tailing: Gradual transition from dark to light shades of the same colour tone in textile printing and dyeing. In the course of this transition one or both edges (listing, side-to-side shading) or the end (ending) of a batch demonstrate lighter or darker colouring as compared with the centre of the fabric.

Tailing and listing: In textile printing and dyeing the gradual transition of a colour shade from dark to light in textile printing and dyeing. See **Tailing**.

Tailors canvas: Buckram; Linen interlining.

Tailors chalk: This is used for marking measurement and pattern details on fabrics. It usually consists of finely pulverised clay or in the form of small plates cut with sharp edges (coloured ones with the addition of mineral dyes), also made of soapstone and talcum.

TAK dyeing: Serves to produce multi-colour effects on carpets. Background colour is first applied to a strip of carpet up to 5 m wide by first dipping/squeezing. Then up to four further batches of dye are floated over the width of the carpet strip using special equipment. To fix the dye, the carpet strip is subjected to steaming and then rinsing processes.

Take-up motion: Loom movement in which the weft is added to the main body of the fabric.

Take up, in fabrics: The difference in distance between two points in a yarn as it lies in the fabric and the same two points after the yarn has been removed from the fabric and straightened under a specified tension, expressed as a percentage of the straightened length.

$$\text{Take up} = [(l_y - l_{\text{fab}}) / l_y] \times 100.$$

Take-up, twist: See **Twist take-up**. The change in length of a filament, yarn, or cord caused by twisting, expressed as a percentage of the original (untwisted) length.

Take-up, yarn: See **Yarn take up**. The difference in distance between two points in a yarn as it lies in a fabric and the same two points after the yarn has been removed from the fabric and straightened under specified tension, expressed as a percentage of the straightened length. In this sense, take-up is contrasted to the crimp of a yarn in a fabric, which is expressed as a percentage of the distance between the two points in the yarn as it lies in the fabric. Take-up is generally used in connection with greige fabric.

Take-up Roller, in openend spinning machines: A pair of closely set, continuously rotating cylinders which withdraw the spun yarn from the rotor.

Talanche: Plain or striped coarse cloth of flax and wool in France; used for garments by the poorer classes.

Talcum: (light white, magnesium silicate, talc), $3\text{MgO} \cdot 4\text{SiO}_2 \cdot \text{H}_2\text{O}$. Density 2.7–2.8. Flaky or crystalline substance, shiny appearance like mother of pearl, (non) transparent, colourless or light white in colour, soft and greasy to touch, not soluble in water. It is characterised by its property of rapidly absorbing moisture.

Talitan: Chinese cotton rugs with overcast edges; used as bed covers.

Tall oil: Tall oil is a by-product obtained from converting wood pulp to paper. The black liquor contains a mixture of triglycerides (about 50%) and rosin (about 45%). The triglyceride portion becomes an important source of fatty acids after it is properly refined.

Tallow: Tallow is the hard fatty deposits in beef and mutton. It contains of 30% palmitic, 14% stearic and 48% oleic acid. Its hard, solid, physical state comes from the high saturated acids content. It is an important source of many softeners because of its abundance and low price. Tallows are often hydrogenated to increase the saturated acid content giving rise to a class of materials called hydrogenated tallow.

Tallow soap: Sodium stearate. Derived from congealed fish-oils. Utilized inter alia as a substitute for Marseilles soap, in particular for soap soda rollers. It is suitable for washing temperatures of 40–60°C.

Tamaito: Japanese term for a grade of silk waste obtained from the duppions.

Tambour: (1) The narrowest size of passing embroidery thread; (2) Embroidery, having- the design executed in in chain stitch on a machine made net ground, with the help of a hook. (3) Smooth, hollow roller (printing cylinder; presser roller), sometimes bombarded with rubberised wool or woollen felt fabric in Rouleaux print. Driven by means of pressure rollers. (4) The central, large cylinder on raising machines and in spinning machinery (carding, combing machines).

Tambour muslin: An open and clear muslin; used for embroideries, curtains, etc.

Tambour Work: Tambour work is of Eastern origin, consisting of embroidery in chain and other stitches over a sheer material stretched in a frame.

Tamet: Woven Term in England, denoting fabrics woven both sides alike and without a wale.

Tamis: Plain and open woven and very smoothly -finished worsted; used for sieves.

Tamise: (1), originally an English, all-wool or silk mixed open face, light fabric. (2), French silk dress fabric, made with satin stripes on a sheer, plain

woven ground; (3), lightweight, thin, plain woven woollen dress goods with a corded face. See **Marquissette**.

Tammies: Twilled, highly finished fabrics of worsted and cotton; used for drapery, etc.

Tangent modulus: The ratio of change in stress to change in strain derived from the tangent to any point on a stress-strain curve.

Tangent modulus: The ratio of change in stress to change in strain derived from the tangent to any point on a stress-strain curve.

Tanglelaced fabric: See **Spunlaced fabric**.

Tanner Dirt contaminated scum formed when scouring woollen goods in the scouring or milling machine.

Tanners' Wool: Is removed from the skin of slaughtered sheep through lime.

Tannic acid: A mixture of compounds derived from oak bark, nutgall and other natural sources; no well-defined chemical composition Tannic acid treatment, followed by treatment with tartar emetic, has been used to improve the wash fastness of dyed wool or nylon. Syntans are now used for this purpose.

Tannic acid/tartar emetic after treatment of Polyamide: Dyeing carried out with acid and metal complex dye substances has improved wet-fastness characteristics (water, sweat and washing fastness). Work process: Rinse after dyeing and treat with 2% tannin and 1% acetic acid (80%) for 15 minutes at 70°C. After the tannic acid has been absorbed, add to the same bath 1% cracked wine lees (potassium antimony(III)-oxide of tartrate) solution and continue treatment at same temperature for 15 minutes and rinse.

Tannic acid/tartar emetic mordant: Dyeing stain with sufficient uptake and fixing of cationic dyeing substances on cellulose fibres, particularly for medium to dark colourations. Used before dyeing with cationic dyestuffs in the dyeing of cellulose, wool and silk.

Tannin: (gall tannic acid, tannic acid). A compound used for tanning earlier days because of its capacity to form insoluble substances with metal salts. Now, its uses are limited. A light coloured powder (Density 1.35) which can dissolve in one part water and two parts alcohol, glycerine and related solvents. It has a strong tanning effect; 0.5% solution precipitates glue and gelatine; in combination with metal salts (iron, copper, mercury, lead) it forms insoluble or barely soluble tannins and in combination with cationic dyeing substances it forms insoluble colour varnishes.

High-quality tannin contains 65–76% tannic acid (best quality 75–80%), Used for staining (superseded by Thiophenols) for cationic dyestuffs (particularly

water tannin); for colour varnish fabrication (colour fastness increase as an after treatment); decrease in the affinity of wool against certain colour substances.

Tanning: Process for refining animal skins or pelts to make leather. It is carried out using Tanning agents and works on the principle of starting with tannage from weaker solution and finishing with concentrated tannage solutions.

Tanning agents (Tannic acids): Chemicals used for tanning animal skins. They are normally soluble in water or forms colloids; it prevent rotting; precipitate glue and protein solutions and convert animal skins into leather; with lead salts they mostly result in insoluble precipitates.

The presence of numerous phenolic-OH groups in the molecule is characteristic.

Tannin stains, removal of: (1) Warm glycerine; (2) 20% solution of tartaric acid (warm/hot); (3) Hot isopropanol.

Tapa cloth: A non-woven cloth, made in the South Seas, of beaten bark fibres of the mulberry tree. Not often used outside the Pacific Islands.

Tape: (1) A narrow, woven fabric not over 8 inches in width. (2) In slide fasteners, a strip of material, along one edge of which the bead and scoops are attached, the bead sometimes being integral with the strip. Also see **Slit tape**, **Non-elastic woven tape**.

Tape ends, in zippers: The tape extending beyond the stops at either or both end of the stringers or to which continuous monofilament elements are attached.

Tape fibres: Spliced, slit or split fibres. Fabricated of sheet materials, Tape yarns or flat threads, cut lengthwise or through lengthwise split fibrils, and cut into staple fibre lengths.

Tape yarn: Yarn of a flat, tape like character produced by splitting an extruded film.

Tape yarns, stretched: Stretched Tape yarns in degrees of fineness ranging from 300–3000 tex.

Tape width, Exposed in Zipper: See **Exposed tape width**.

Tape, in textiles: A narrow fabric with a mass per unit area of less than 0,5 kg/m² (0.1 lb/ft² or 15 oz./yd² or 510g/m²) or 26 lb./100 yd per 1 in.(25.4 mm) of width and which is used primarily for utilitarian purposes.

Tape, in Zippers: A strip of material along the edge of which the bead and elements are attached.

Tape, elastic: See **Elastic tape**.

Taped: Two or more separate warp ends run through one heald and woven as one.

Tapestry: A highly ornamental fabric, woven on a jacquard loom, which has an embroidered look. Cotton and worsted yarns are used in many colours, usually showing a picture. A heavy fabric used for upholstery, curtains and bedspreads. At the present tapestry is made either on high (vertically stretched) or low (horizontal) warp, the principle being the same in both cases. The stout warp is stretched, from 8 to 22, within an inch space, and the patterns worked from the wrong side by means of small shuttles. In the design only the filling is visible. Each weft extends continuously only the width of that particular coloured field, the edges of these different coloured fields being properly interlaced with each other to form a continuous fabric. When in use the tapestry is hung with the filling running vertically. Tapestries are ornamental textiles, used mostly for covering walls, curtains and also for upholstery. They are distinguished by the style as verdures, gothic renaissance, etc., and by the origin. Since the 12th century Arras, in France, also Brussels and Lille, were the most famous places for tapestries, succeeded by the Gobelin, Savonnerie, Beauvais and Aubusson tapestries since the 17th century.

Tapestry Back: A single shed back, given to carpets in order to increase their wearing quality.

Tapestry Carpet: It is made with three sets of warps, one forming the loop pile, and only one frame. The pile warp is printed before weaving with the desired pattern in any number of colours, this being the difference between the tapestry carpet and Brussels carpet, although the two are similar in appearance.

Tapestry needles: These hand sewing needles are stout needles with a long eye and a blunt point. They are used for pulled and drawn work and silk ribbon embroidery.

Sizes 13 to 28.

Tapestry Stitch: Similar to gobelin stitch.

Tapestry velvet carpets: A cut pile carpet woven from printed pile warp or single frame of yarn. It was traditionally woven on a tapestry carpet loom with bladed wires.

Tapestry weave: A weft-faced plain weave where the weft threads are packed closely together so that the warp is hardly seen. Tapestry is often associated with the large pictorial wall hangings of medieval and later Europe. However, strictly speaking, tapestry is a distinctive woven structure- a weft-faced plain weave with discontinuous wefts.

Tapeta: Carpets and rugs of ancient Egypt, mentioned by Homer; some made with linen warp and woollen weft.

Tapis: French for 1, carpet; 2, several fancy Oriental fabrics.

Tapiserie: French for tapestry.

Tapiserie d'Auxerre: Consists of net embroidered with soft wool yarn in satin stitches, forming geometrical designs.

Tar stains, removal of: First remove the dark (dark brown or Black) stains with the following chemicals and the again rework the left out yellow stains with the solvents given afterwards. (a) benzene; (b) benzene/carbon tetrachloride (or tri-, tetrachloroethene) 1 : 1, possibly with glycerine (= dye protection) in equal parts; (c) carbon disulphide or acetone; (d) chloroform (ether)/carbon tetrachloride; (e) benzene/carbon tetrachloride 1 : 5 with diethyl ether/ethanol. If this does not produce satisfactory results, soak with concentrated grease-solvent soap (possibly overnight). Rework yellow stains: (a) 3% ammoniac; (b) (silk) 20% sodium tetraborate solution, possible reductive post-bleach; (c) particularly for brown residues: Mixture of 75% oleic acid and 25% carbon disulphide, rinse with pure solvent.

Tarare: (1) French, pure or cotton mixed linen of good quality, used for curtains; (2) French hemp canvas, unbleached; made about 27 inches wide and used for furniture covering.

Tare: The mass of all external and internal packing materials (including bobbins, tubes etc.) of a case, bale, or other type of container, varying from less than two to over five per cent of the total weight.

Tarlatan: An open, plain-weave coarse cotton with a starched finish, resembling coarse net. Highly inflammable. Used in millinery and for stiffening belt as well as for extra stiff petticoats or bustle effects. Often used for stage costumes.

Tarlton: Plain woven, very open and light cotton fabric, dyed in the piece. Used for dresses, etc. See **Tarlatan**.

Tarmate: Waste silk, obtained from stained or imperfect cocoons.

Tarpaulin: Water-resistant fabric used to protect loads or materials from the elements. May be a coated fabric, a fabric with waterproof finish, or a fabric that is tightly constructed to prevent water penetration.

Tartan: (1) Authentic Tartan designs belong to individual Scottish clans, although they are now worn by many other people. The cloth is woollen or worsted in twill weave, each tartan is an elaborately coloured check design. The traditional garment is the pleated kilt, but tartan cloth is also used for trousers, shawls and fashion garments. Elaborately checked fabric is available which is not authentic tartan, often made from acrylic and blends of wool

and acrylic or cotton. The weight of the cloth varies considerably; handle according to fibre content and thickness. (2) woollen or worsted dress goods woven in twill or basket weave in plain patterns, usually in blue, green, red and yellow colours; (3) In Argentine, Uruguay and Paraguay flannelettes, woven with plaid patterns and napped on both sides. Some of the better grades are also made of wool.

Tartan checks: See **Tartan**.

Tartan fabric: (plaid fabric). Does not denote origin but is a generic term for all boldly-checked fabrics with predominantly green, red and blue colour shades. Woollen tartan fabrics can be fabricated from carded yarn or worsted filaments; important is the strong patterning.

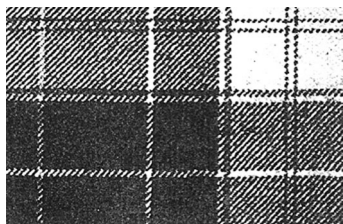

Tartan

There are distinct summer and winter weights. The most frequent weave is the 1:4 twill, in same-sided twill as well as Plain weave. Worsted tartan fabrics are usually sheared; those made of carded yarn have a clear surface to lightly milled, occasionally also finished with long combed finish, causing the colours to flow delicately into one another. Used for dresses, skirts and coats.

Tartanella: Tartan plaids made of wool mixed with cotton or linen.

Tartar emetic: Antimony potassium (or sodium) tartrate This was once commonly used with tannic acid to improve the wash fastness of dyed wool or nylon.

Tartaric acid: (dioxy succinic acid), $C_4O_6H_6$ molecular weight 150; density 1.759. Salts = tartrates. Tartaric acid is a strongly dissociated acid (1% solution pH 2.1; 10% solution pH 1.6). Has a harmful effect on fibres when they are subjected to solution steam; reducing agent. Softening of textiles and silk scroop fabrication (silk, viscose); preservation agents (finishing agents for protein-based substances); spotting agents (lightening, freshening, etc.).

Tasar silk: See **Tussah silk**.

Tassel: Tufts of cotton, wool, silk, metal or chenille yarn, with a more or less ornamental head and a long, open or looped end. The finer qualities are used

for dress and coat trimmings, while the heavy grades are used on curtains and upholstered furniture.

Tassel Cloak: Semi-circular shoulder cape closed at the front by a cord or chain on a pair of decorative plates (tassels).

Tassel Stitch: In Berlin wool work for making fringes and is a variety of the plush stitch (see); it is worked with a mesh and the wool doubled.

Tatami mats: Smooth floor covering, frequently used in Japan, made of Tatami straw. This is derived from Tatami grass, a type of rush cultivated in Japan, China and Taiwan.

Tato: Abbreviation of the German Tagestonne dayton(s), tons/day.

Tattersall: Large, loud check woollen cloth. Often in black and white with another colour. Often worn on race course. Used for overcoats, caps, hats, and capes for men.

Tatting: A lacy work of varying coarseness, depending on the thread used (usually crochet thread) It is worked using a shuttle with thread wound on to it, and using the fingers of the other hand in conjunction with it. Usually used only for edgings, motifs or table mats.

Taunton: A medium and coarse grade of English broadcloth, weighing 11 oz. per yard; was made since the 16th century.

Taunton Serge: 18th century worsted serge in England; worn by women.

TCF Process: (textiles continuously formed). Direct technique for fabrication of spun fleeces and spot bonded nonwovens fabricated of viscose. Spun threads contain the components hydrozyl methyl cellulose xanthate (HMCX), cellulose and caustic cellulose in concentrated ringed layers. The thermoplastic component is HMCX, which has a sticking effect during hot calendaring of the spun fleece and is transformed into cellulose during the process. A bonding agent is not required.

Tcharhad: Little square hand knotted rugs in Persia.

Tchechen Rugs: See **Chichi rugs**.

Tchembert: White or fancy cotton muslin in Turkey.

Tcherkess Rugs: See **Circassian rugs**.

Tcheutche: Closely woven, very soft Chinese washable taffeta. It does not crease and is used for garments.

TDI: Abbreviation for toluene diisocyanate.

Tear: Percentage of tops to noils. A 4:1 tear would refer to wool that had 20% waste.

Tear drop, in woven fabrics: A fabric condition characterised by short elliptical deviations of one or more adjoining picks. Tear drops are most pronounced in taffetas and grosgrain weaves.

Tear resistance, in textiles: The resistance to the tearing force applied on a material.

Tear strength: The force necessary to tear or tear through a strip of fabric in the direction of its length. Measurable with special clips on the tensile strength tester, where values can be read directly from a scale.

Teariness: See **Tear drop**.

Tearing energy: The work done in tearing a material.

Tearing force: The force applied to propagate a tear initiated under specified conditions. It is the work done in tearing the specimen divided by twice the length of tear.

Tearing strength: The force required either (a) to start or (b) to continue or propagate a tear in a fabric under specified conditions.

Tearing strength, in fabrics: The capacity of a material to withstand the ultimate tearing force required to propagate a tear after its initiation.

Tearing tester elmendorf: Used to establish initial tearing and further tearing values (= Elmendorf values) of particularly highly refined cotton fabrics by applying a strain with pendulum stroke testers.

Tease: To open and disentangle fibres prior to carding.

Teasel: (1) Process to raise the nap, especially of woollens, by scratching the cloth.

(2) A plant with a large prickly head (*Dipsacus fullonum*) used for raising or fulling fabric.

Teasel cards: Dry teasel plant heads for rod teasel machine and roller card raising machines. See **Raising machines**.

Teasel Cloth: Another name for nap faced fabrics.

Teazer: See **Willey**.

Technical grade: A term applied to chemicals sold for general industrial purposes. Technical grade chemicals are usually somewhat less pure than "reagent grade" or "analytical grade" chemicals, and are much cheaper. Technical grade is now rather rare in small packages from laboratory chemical suppliers. Package sizes from industrial chemical vendors often range from about 25 kg or 50 pounds up to rail car lots. "Tech" grade chemicals are very suitable for textile dyeing. Also see grades of chemicals.

Technical textiles: Frequently used term for textiles used for technical purposes, for preventive or auxiliary functions in consumer and utility goods as well as in the production of goods and services (Industrial textiles). These are textiles, whose fibre substance and form, texture or weaving technique, impregnation, coating, rubberising or composite construction render them independent technical products, are used in technical products, or demonstrate technical or special industrial properties. Another definition is textile materials and products manufactured primarily for their technical and performance properties rather than their aesthetic or decorative characteristics'. 2 groups of technical textiles:

- *Agro tech:* Agriculture, Aquaculture, Horticulture and Forestry.
- *Build tech:* Building and Construction.
- *Cloth tech:* Technical components of footwear and clothing.
- *Geo tech:* Geotextiles and Civil engineering.
- *Home tech:* Technical components of furniture, Household textiles and Floorcoverings.
- *Indu tech:* Filtration, conveying, cleaning and other industrial uses.
- *Med tech:* Hygiene and Medical.
- *Mobil tech:* Automobiles, Shipping, Railways and Aerospace.
- *Oeko tech:* Environmental protection.
- *Pack tech:* Packaging.
- *Pro tech:* Personal and property protection.
- *Sport tech:* Sport and Leisure.

Techum fibre: Palm fibres (Brazil), white and solid, similar to flax, sometimes coarser, high moisture absorbency without feeling damp, used particularly for upholstery material.

Tedco mercerising process: Technique developed by the Norwegian Textile Institute and the Institute for Industrial Research in Oslo for treating fabrics in liquid ammonia. The technique is derived from the Prograde process. The fabric is passed through liquid ammonia at $-33/35^{\circ}\text{C}$ causing an immediate reaction to occur. Reaction time is 10 seconds maximum. The fabric is then stretched and fed over heated drums where the ammonia evaporates and is recycled, except for a residue of 3%. The remaining 3% can be removed by steaming. The resulting ammonia steam mixture is incinerated.

TEGEWA: German association of textile and leather aids and staining and washing raw material industry (Verband der Textilhilfsmittel-, Lederhilfsmittel-, Gerbstoff- und Waschrohstoff-Industrie e.V.).

Teklan: Courtalds modacrylic fibre. It is strong and hard wearing but also soft, warm and light and can be bulked. It has good resistance to sunlight, bacteria and chemicals and above all nonflammable. Used mainly in woven and knitted dress materials, and household textiles, such as net curtains, and furnishing materials.

Telomer: See **Telomerization**.

Telomerization: The formation of an addition oligomer. So-called specific Polymerization uses compounds (so-called "telomer") resulting in end groups, which are determined in advance, and renders possible a controllable, stage-by-stage increase of polymerization by addition 1 : 1, 1 : 2, 1 : 3, 1 : x up to several thousand. Telomerization results in a wide range of synthetic waxes, plasticizing agents, lubrication oils, textile aids, plastics, synthetic fibres, etc.

Temperature of zero birefringence: The temperature at which the refractive indexes of a material are equal in two perpendicular directions (longitudinally and transversely for a fibre).

Temple: A part of the loom helping in the draw of the fabric after weaving. See **Temple mark**.

Temple mark, in woven fabrics: Small holes, impressions, marks or distortions adjacent to the selvedge caused by poorly adjusted or improper temples. See also **Bad temple, pick up place, rough place**.

Temporary hardness: The hardness of water due to bicarbonates. This hardness can be removed by boiling of the water, which converts bicarbonates to carbonates, which are not attributing to hardness.

Temporary stitches: Stitches, which are ripped off after a permanent stitch has been made, are called temporary stitches. For example-Basting stitch, Permanent stitch.

Tenacity, in a tensile test: The force exerted in the specimens based on the linear density of the unstrained specimen.

Tenacity: The tensile strength expressed as the force per unit linear density of the unstrained specimen.

Tenacity: The tensile stress when expressed as force per unit of the linear density of the unstrained material. For e.g. gf/tex.

Tenacity The maximum specific strength of a fibre or yarn that is developed in a tensile test taken to rupture point.

Tenacity-at-rupture: The tenacity of the force-at-rupture.

Tenacity-as-specified elongation (TASE): The tenacity of a material at its force-at-specified-elongation.

Tenacity, breaking: See **Breaking tenacity**. The tenacity corresponding to the breaking load for e.g. gf/tex.

Tencel®: Acordis Fibres (Holdings) Ltd. trademark for their lyocell regenerated cellulose fibres There are two types of TENCEL®. “Conventional” TENCEL®, is subject to vibrillation, which is exploited to produce a “peach skin” finish. TENCEL® A100 is treated to cause cross-linking of cellulose fibres, which prevents fibrillation. TENCEL® has much higher wet strength than other regenerated cellulose fibres such as viscose rayon. It can be dyed much like cotton.

Tender Fleece: A sort of wool separated in wool sorting from others; they have a weak place in the fibre.

Tender Wool: Wool below the normal tensile strength.

Tendering: Weakening of a fibre, normally meaning as a result of chemical degradation Cellulose fibres can be tendered by acids or by excessive action of *oxidative bleaches*.

Teneriffe Work: Consists of making laces similar to the filet with starlike patterns.

Teneriffe Lace: An inexpensive lace typified by a wheel design or spiders web motif. These are often joined to make mats or added to table linen. It is similar to Paraguay Lace.

Tennis Flannel: Same as outing flannel.

Tennis Shirting: Soft, twilled, cotton or woollen shirting, made in fancy stripes, often napped on the back.

Tennis Stripes: Light, twilled woollen dress goods with narrow, coloured stripes.

Tensile: Relating to tension in, or on a material.

Tensile elasticity: The most important type of Elasticity which is measured after pre-tensioning under gradually increasing load (stress-strain behaviour). Evaluation of the figures to attain, for example:

- (a) Elastic elongation: Retraction of the test specimen when the load is removed as % of the initial length.
- (b) Degree of elasticity: Ratio of elastic elongation to overall elongation, as %.
- (c) Modulus of elasticity (E-modulus): Ratio of tensile stress to the elongation unit. Measure of the resistance of a fabric to changes in form.

Tensile force (Load): (tensile load). The force in the direction of traction acting on the test sample at any one time during a simple Tensile strength test: the maximum measured tensile force on rupture of the test sample is known as the maximum tensile force; in relation to fineness = tensile strength; in relation to the initial cross-section = tensile stress.

Tensile hysteresis curve: A complex load elongation or stress strain curve obtained under either (a) when a specimen is successively subjected to the application of a load or force less than that causing rupture, and the removal of the load or force according to a predetermined procedure, (b) When a specimen is stretched less than the breaking elongation and allowed to relax by removal of the strain according to a predetermined procedure.

Tensile recovery curve: See **Tensile hysteresis curve**.

Tensile strain: The strain on a material subjected to tension. The relative length deformation exhibited by a specimen subjected to a tensile force. Strain may be expressed as a fraction of the nominal gauge length or as a percentage. Also see **Elongation**.

Tensile strain recovery: The percent of recoverable extension impressed on a fibre under specified conditions.

Tensile strength: The maximum resistance of a material to deformation in a tensile test carried to rupture; that is, the breaking load, or force, per unit cross sectional area of the unstrained specimen.

Tensile strength: The strength shown by a specimen subjected to tension, as distinct from torsion, compression or shear.

Tensile strength: The strength of a material under tension as distinct from compression, torsion or shear.

Tensile strength: The breaking load (or force) per unit cross sectional area of the unstrained specimen.

Tensile strength tester: Testing machine to find out tensile strength of a material.

Tensile stress: The stress within a material subjected to tension. The resistance to deformation developed within a specimen subjected to tension by external force. The tensile stress is commonly expressed in two ways, either as (a) the tensile strength, i.e., the force per unit cross-sectional area of the unstrained specimen, or as (b) tenacity, i.e., the force per unit linear density of the unstrained specimen. The latter is more frequently used in textile testing.

Tensile stress: In a Tensile strength test the quotient from the Tensile force and the initial cross-section.

Tensile test, in textiles: A test in which a material is extended in one direction to determine one or more of its force-extension, or stress-strain, characteristics; for example, breaking force, elongation at break.

Tensile testing machine: An apparatus designed to impart or transmit, force/extension, or stress/strain, to a material and to measure the effect of the action.

Tension: A uniaxial force tending to cause the extension of a body or balancing force within that body resisting the extension.

Tension-recovery chart, in tension testing: A continuously plotted graph of tension versus extension resulting from a tension recovery cycle.

Tension-recovery cycle, in tension testing: The continuous application of tension on specimen with a momentary hold at the maximum tension, followed by a return to zero tension at a controlled rate.

Tension bar: A bar composed of weft yarn that has been stretched more, or less, than the normal weft prior to, or during, weaving. This abnormal stretch may have been imposed: during winding, by faulty manipulation or by some mechanical fault in the machine; during weaving, by incorrect tensioning in the shuttle; or may have arisen owing to the faulty yarn having been excessively moistened at some stage and consequently stretched more than the normal yarn under the normal applied tensions. Such a bar may appear as a Cockled bar in those cases where stretch has been sufficient to cause cockle on subsequent contraction of this weft.

Tension box, in weaving: When a warp is wound sectionally, it is first threaded in a tension box that tensions each thread evenly and spreads the threads to the width of the section.

Tension, loop: See **Loop tension**.

Tension Control Weave: A type of decorative weave, characterized by a puckered effect which occurs because the tension in the warp yarns is intentionally varied before the filling yarns are placed in the fabric.

Tension test, in textiles: A test designed to measure the tautness in a textile strand or fabric.

Tent fabric: Stout waterproof cotton duck or canvas, used for tents and awnings.

Tent Stitch or Petit Point: In embroidery only half of the cross stitch, repeated.

Tenter frame: A machine that dries fabric to a specified width under tension. The machine consists essentially of a pair of endless chains on horizontal tracks. The fabric is held firmly at the edges by pins or clips on the two chains

that diverge as they advance through the heated chamber, adjusting the fabric to the desired width. Also called Stenter frame.

Tenterhook willow: See **Willey**.

Tenter Mark: See **Stenter mark**. A visible deformation on the side edge body of a fabric caused by due to pressure from clips or pins.

Tenter Mark: See **Clip mark**.

Tenuguiji: A soft and plain woven cotton fabric; used as toweling in Japan; it comes in 12 and 15 inch widths and often hand printed. It is also used for table covers, center pieces and extensively for advertising.

Terephthalic Acid: Para-phthalic acid, $[C_6H_4(COOH)_2]$. Used to produce polyester resins, fibres, and films by combination with glycols.

Terinda: This is a special polyester fibre made by ICI.

Terpenes: **Turpentine, pine oil etc. which are handy as stain removers, solvents and emulsifiers comes under the chemical group of Terpenes.** They are cycloaliphatic and hydro-aromatic hydrocarbons with the general formula $(C_5H_8)_n$ Used in components for solvent soaps or emulsions for

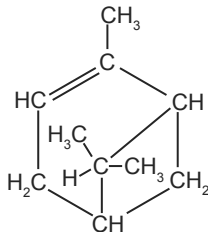

boiling cotton, for linseed oil sizing agents, antifoam agents, for dissolving rubber, polyacryl acid esters and artificial resins (for print thickeners), for stain removing purposes, etc.

Thermal Insulation: The ability of a fabric to retain heat.

Thermoregulation: The ability to maintain a constant temperature independent of dynamic (changing) environmental conditions.

Terpolymer: A product of the polymerization of three different monomers.

Territory Wool: A designation originally given to wools originating in regions west of the Missouri River. Now applies to western range wools, not including Texas and California.

Terry Cloth: First used in terry towels or Turkish towels, terry cloth is used in so many ways as beach wear, sportswear etc. today. It is woven with two sets

of warp and one filling, one warp forming rows of loops on the face or back or on both sides, which are not cut. It comes bleached, dyed, in coloured patterns or printed. The loop piles can cover the entire cloth or form patterns. It is made of cotton, linens, wool or silk and used for a great variety of purpose. When made of cotton or linen it is also called Turkish toweling. The warp which forms the loops is dressed on a separate warp beam and is kept very slack. In weaving, a number of picks are let in, quite far apart from each other, before beaten up hence terry is designated as 3, 4, 5 or 6 pick, according to the number of picks put in in one row of loops. When the picks are beaten up they will slide over the stoutly stretched ground warp but the friction is sufficient to pull the pile warp with it, the section of that warp between each pick, originally far apart, forming a loop on any or both sides when beaten up. A normal terry construction for apparel use in 64 x 24 with 16s cotton warp and filling. Frequently the pile warp yarn is more loosely twisted than ground warp yarn to obtain greater absorbency. It comes in stripes, checks, plaids effects in various colours. Used for towels, bathrobes, etc.

Terry cloth identification: (1) *Frotté*: (a) woven on standard weaving machine, (b) looped fabric surface, (c) effect may be produced by using frotté, (d) loops cannot be pulled out. (2) *Terry fabric*: (a) woven on terry weaving machine, (b) loops formed by the pile warp, (c) loop thread can be pulled out in the warp direction.

Terry Fabric: A material with a woven warp pile or a knitted fabric, with uncut loops on both sides, and which is used for such products as toweling, beachwear, and bathrobes.

Terry Towel: A textile product with end hems or fringes and side hems or selvages which is made with loop piles on one or both sides, generally covering the entire surface or forming stripes, checks or other patterns.

Terry Velour: A pile weave cotton fabric with an uncut pile on one side and a cut pile on the reverse side. Terry velour is valued for its soft, luxurious hand. Typical uses include towels, robes, and apparel.

Terry Velvet: A velvet with a looped pile, produced in the same way as the Terry Toweling.

Tertiary Colours: Shades that are obtained by mixing the three primary colours or by mixing one or more of the secondary colours with gray or black.

Terylene: ICI's polyester fibre, produced from petroleum and its byproducts. It can be successfully bulked. It is extremely hard wearing and mixes well with many other fibres such as cotton, wool, viscose etc. It does not catch light but melts. Used in all types of dresses and furnishing fabrics.

Teshike: Lightweight Japanese silk cloth, treated against perspiration.

Testbeard, in length testing of cotton: A portion of the test specimen that has been combed and brushed into a 'beard' which protrudes from the outside of the comb(s) or clam(s).

Test: (1) A single observation made on one (test) specimen.

(2) A series of observations of which the average, or some other function, is considered a significant result for a sample.

Test beard, in length testing of cotton: The portion of the test specimen that has been combed and brushed into a 'beard' which protrudes from the outside of the comb(s) or clamp(s).

Test method: A definitive procedure for the identification, measurement, and evaluation of one or more qualities, characteristics, or properties of a material, product, system, or service that produces a test result.

Test skein: A small skein which has a prescribed length of yarn and is used for determination of linear density or breaking load or both.

Test specimen: The cotton fibres placed randomly on a pair of Fibrograph combs for fibre length measurements.

Test specimen, in cotton length with the length Analyzer: The cotton fibres protruding randomly from the base of a Motion Control inc., specimen clamp for fibre length measurement before being combed or brushed.

Test specimen in cotton maturity tests: The series of slides observed by one technician as one half of the test.

Test specimen, wool top: A length of specified mass taken at random from a length of wool top selected as a lab sample.

Test specimen: See **Specimen**.

Test, tensile: See **Tensile test**.

Test, tension: See **Tension test**.

Tete de Negre: (1) French name for a dark brown colour; (2) French woollen fabric with a knotted face, similar to petersham.

Tetrachloroethylene: (perchloroethylene, per) C_2Cl_4 . Colourless fluid, clear as water, neutral, evaporates rapidly, characteristic smell, anaesthetizing, nonflammable. Stabilized, non-decomposed tetrachloro ethylene corrodes metals at temperatures up to 140°C even if water is not present. Advantages of tetrachloro ethylene compared with water for cleaning outer clothing: textile compatibility: no fibre swelling, no shrinkage, causes no deterioration

of shape; high density: stable for use in highly-mechanized processes, good dirt removal properties; low surface tension: rapid moistening, rapid dirt penetration; grease dissolving: cleaning without temperature increase; rapid evaporation; rapid, energy-saving drying; low evaporation heat: bath regeneration by means of distillation, waste concentration in residue, well directed disposal. As far as the care of outer clothing is concerned, Dry-cleaning has advantages with regard to maintaining the value of the textiles and to cleaning performance, lower time requirement, lower energy requirement and lower material consumption, since the solvent used is always recovered and the residue is disposed of efficiently. The use of tetrachloro ethylene does, however, involve certain risks.

Tetrafluoroethene: (CF₂:CF₂) A gaseous organic compound (a fluorocarbon and a haloalkene) used to make the plastic polytetrafluoroethene (PTFE). See **polytetrafluoroethene**.

Tetrafluoroethylene Fibre: See **Polytetrafluoroethylene fibres**.

Tetrakis (Hydroxymethyl) Phosphonium Chloride (THPC): THPC is the most important commercial derivative and is prepared from phosphine, formaldehyde and hydrochloric acid at room temperature. It contains 11.5% phosphorous and is applied by a pad-dry-cure → oxidize → scour process. $\text{PH}_3 + 4\text{CH}_2\text{O} + \text{HCl} = (\text{HOCH}_2)_4\text{P}^+\text{Cl}^-$ The compound is highly reducing in character and the methylol groups condense with amines to form insoluble polymers. It is applied with urea, dried and cured. Control of pH and the oxidation state of the phosphorus is important in determining the flame retardant properties and the durability of the finish. The release of HCl may cause the fabric to tender during curing unless pH is controlled. The final step in finishing requires oxidation of P+3 to P+5 with hydrogen peroxide. This step too must be controlled to prevent excessive tendering of the fabric. An alternative to the THPC is THPS. Sulfuric acid is used instead of HCl and the corresponding phosphine sulphate is formed in place of the phosphine chloride.

Tetrakis (Hydroxymethyl) Phosphonium derivatives: The bulk of today's durable flame retardant for cellulose centers around the use of derivatives of tetrakis (hydroxymethyl)- phosphonium salts (THP). These derivatives can be applied by padding, drying, curing and oxidizing to yield serviceable flame retardant fabrics. Add-ons are high and the handle of the fabric is stiffer so the finish is normally used for protective clothing applications.

Tetrakis (Hydroxymethyl) Phosphonium Hydroxide (THPOH): THPC is usually partly neutralized with amines, amides and/or alkali. Complete neutralization of THPC with sodium hydroxide yields a compound referred

to as THPOH. The distinction between THPC used in a partially neutralized condition and THPOH is difficult to define. If the curing agent is basic as is ammonia, the distinction become meaningless. THPOH-ammonia has received a great deal of commercial attention. The major advantage over THPC is reduced fabric tendering and reduced stiffness. Fabrics padded with THPOH give off formaldehyde during drying.

Tex: A unit for expressing linear density, equal to the mass in grams of yarn, filament, fibre or other textile strand. It is the mass in grams of 1000 metres of fibre, yarn, or other textile strand, that is used in a direct yarn numbering system. The multiple and submultiples recommended for use are the following:

Kilograms per kilometre kilotex (ktex)

Milligrams per kilometre millitex (mtex)

Decigrams per kilometre decitex (dtex)

Example: A yarn of 2.5 km has a mass of 40g. $Tt \text{ (tex)} = 40/2.5 = 16 \text{ tex}$

In case of folded and cabled yarns, individually yarn number is indicated, followed by a multiplication sign and the number of components.

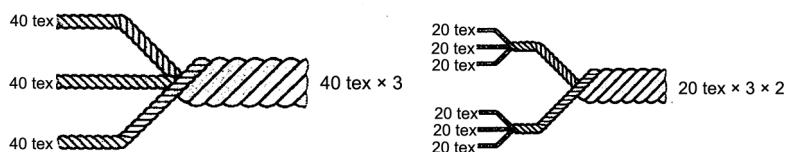

Tex System The direct decimal system based on metric units that has been adopted by ISO as a universal system for designating the linear density of fibres, filaments, slivers and yarns.

Tex ticket number: The designator assigned to a sewing thread to indicate the approximate linear density.

Texas: General trade name of cotton grown in Texas and Oklahoma, the staple measuring from seven-eighths to one inch in length and varying in quality according to the season.

Texas Storm: Proof Commercial variety of late maturing upland cotton, the staple measuring 23–26 millimeters; the yield is 33–35 per cent.

Texas Wood: Commercial variety of medium maturing upland cotton, the staple measuring 22–25 millimeters; the yield is 34–36 per cent; also called Peterkin.

Textile: Originally a woven fabric, now generally applied to; (a) Staple and filament suitable for conversion to or use as yarns, or the preparation of on

woven fabrics, (b) Tarns made from natural or man-made fibres, (c) Fabrics and other manufactured products made from fibres as defined earlier , and (d) Garments and other articles fabricated wholly from one or more of the above elements, and articles made principally from the above when the products retain the characteristic flexibility and drape of the original fabrics. Any item manufactured from natural or man-made fibres or filaments, e.g. yarns, threads, cords, ropes, braids, lace, embroidery, nets and fabrics made by weaving, knitting, braiding, felting, bonding and tufting.

Textile Auxiliaries: (assistants, agents processing aids), considered as belonging to Textile chemicals. Textile auxiliaries on the one hand make it possible to or have a positive effect on the execution of a textile process, and on the other hand have a positive effect on quality, efficiency by helping to reduce or eliminate faults and damages. Textile auxiliaries are thus found in all types of textile processes from fibre production, processing, finishing and make-up of finished goods to subsequent textile care in washing, dry cleaning and soil removal.

Textile care: This encompasses the maintenance of efficiency of textiles including amongst other things. See **Textile cleaning**.

Textile chemicals: All chemicals (including Textile auxiliaries), which are used in Textile finishing and should be biodegradable.

Textile fibre, general: A generic term for the various types of matter that form the basic elements of textile fabrics and other textile structures.

Textile fibre, specific: A unit of matter that is characterized by having a length at least 100 times its diameter or width and which can be spun into a yarn or made into a fabric by interlacing in a variety of methods, including weaving, braiding, knitting, felting and twisting.

Textile Fabric: A planar structure consisting yarns or fibres.

Textile finishing: Textile finishing usually includes treatments such as scouring, bleaching, dyeing and/or printing, the final mechanical or chemical finishing operations, that during this stage are carried out on textile products (staple, sliver or top, yarns or filaments, woven or knitted fabrics) to enhance their basic characteristics like dye penetration, printability, wettability, colour, hand, and appearance. By textile finishing, also mean all the processing operations that, though included in the so called finishing stage, are generally applied to the fabrics to improve their appearance, hand and properties, at times in accordance with their field of application.

Textile Floor Covering: A product having a use-surface composed of textile material and generally used for floor covering.

Textile labeling: Details of the raw material composition of textile products. (a) Between processing stages as a rationalization measure. (b) For the consumer as a protective measure when purchasing textiles in accordance with Textile labeling regulations.

Textile markers: (1) Textile markers in the form of paste in tubes for marking raw materials with 4 different writing heads (for different types of material), resistant to all finishing stages. (2) (markers, fabric markers, signal markers) are used for Marking of grey fabrics in wet and/or dry processing (fabrics, number strips, garment bags, laundry). Suited to each process type (finishing, dry cleaning, laundering) with appropriate fastness and yet capable of being easily removed (e.g. with soap). Colours usually white, yellow, red and black. Textile marker types: Liquid as inks, semi-liquid in tubes or pens, solid as pencils.

Textile Materials: A general term for fibres, yarn intermediates, yarn, fabrics, and products made from fabrics that retain more or less completely the strength, flexibility, and other typical properties of the original fibre or filaments.

Textile Modulus: Obsolete term, See **Young's Modulus**.

Textile Processing: Any mechanical operation used to translate a textile fibre or yarn to a fabric or other textile material. This includes such operations as opening, carding, spinning, plying, twisting, texturing, coning, quilling, beaming, slashing, weaving, and knitting.

Textile ribbon: See **Ribbon, in textiles**. A fine textured, narrow fabric which weighs less than 2.6 lb. per 100 yd. per inch of width (approximately 15 oz./yd² or 510 g/m²) and which is used primarily for trimming or decorative purposes.

Textile Standards: In many countries it is the responsibility the Specialist Standards Committee of the Textile and Textile Machinery Industry to establish of standards for the entire textile industry, textile machinery constructors and the clothing industry and are issued by them as standards for that country. In the area of textile testing methods they work closely with the specialist standard committee for "Materials Testing". See **Industrial standards**. These Standards are available everywhere so that one country can refer the requirements of another country when the former is exporting to the latter.

Textile Whiteness Scale: (textile whiteness standard, cotton whiteness standard), derived from the Ciba-Geigy white standard. Division into 18 sections (each comprising 10 units) on a scale from 70 to 240. The lowest section of 70 is applied to max. bleached, non-brightened cotton and the highest level of 240 to intense white effects achieved with optical brighteners.

See **Whiteness scale**.

Textile tape: See **Tape, in textile**.

Textile, webbing: See **Webbing, in textile**.

Textile, non-combustible: See **Noncombustible textile**.

Textile-reinforced concrete. In fibre-reinforced concrete the fibres are short [usually no longer than 2 in. (5 cm)] and discontinuous, textile-reinforced concrete contains continuous woven or knitted mesh or textiles. Conceptually, such reinforcement acts similarly to conventional steel reinforcing bars or welded steel wire fabrics. But these fabric materials are noncorrosive and can have mechanical properties that are superior to those of steel. The fabrics can be pre-manufactured in a wide variety of ways, thereby lending themselves to new applications, especially for repairing or strengthening existing concrete structures.

Textiles: These are understood to include half- and fully-finished fabrics made from spinnable Fibres. They are therefore structures which consist of textile fibres in their smallest components and are further processed by means of textile processes (spinning, weaving, knitting, etc.). Textiles are frequently influenced more by their structure than by the type of fibre.

Textometer: Device for measuring moisture content of textiles which determines the residual moisture using the principle of conductivity. There are various versions of the device: easily transportable battery unit, universal device for monitoring processes as well as a version with electronic regulation for monitoring and automatic control of sizing machines, fabric driers and the like.

Textured Fabric: Fashionable fabrics for underwear, clothing and outerwear with raised or depressed waffle-like pattern effects (lace-like tied warp and weft threads).

Texture: The surface appearance and hand of a textile material. A term describing the surface effect of a fabric, such as dull, lustrous, wooly, stiff, soft, fine, coarse, open, or closely woven; the structural quality of a fabric.

Texture, in carpets or pile floor coverings: The detailed configuration of loops, cut pile ends, and individual fibres in a pile layer.

Textured: An adjective used to describe continuous filament manufactured yarns (and woven and knit fabrics made therefrom) that have been crimped or have had random loops imparted, or that have been otherwise modified to create a different surface texture. Also see **Textured Yarns and Texturing**.

Textured glass yarn: A yarn processed from continuous filament yarn in such a manner to induce bulk to the yarn by disorientation of filaments.

Textured Yarn: (1) A yarn that has been so processed as to introduce durable crimps (q.v.), coils, loops or other fine distortions along the length of the fibres or filaments.

(a) The main texturing processes usually applied to continuous-filament yarns made from or containing thermoplastic fibres, are as follows:

- (i) The yarn is highly twisted, heat-set and untwisted, either as a continuous process (false twisting) or as a three-stage process. This continuous method for producing textured yarns utilizes simultaneous twisting, heat-setting, and untwisting. The yarn is taken from the supply package and fed at controlled tension through the heating unit, through a false-twist spindle or over a friction surface that is typically a stack of rotating discs called an aggregate, through a set of take up rolls, and onto a take-up package. The twist is set into the yarn by the action of the heater tube and subsequently is removed above the spindle or aggregate resulting in a group of filaments with the potential to form helical springs. Much higher processing speeds can be achieved with friction false twisting than with conventional spindle false twisting. Both stretch and bulked yarns can be produced by either process. Examples of false-twist textured yarns are Superloft[®], Flufflon[®], and Helanca[®]. (Also see **Textured yarns, Coil Yarn.**)
- (ii) The yarn is passed through a heated “stuffer box” (stuffer box crimping). The crimping unit consists of two feed rolls and a brass tube stuffer box. By compressing the yarn into the heated stuffer box, the individual filaments are caused to fold or bend at a sharp angle, while being simultaneously set by a heating device. (Also see **Textured yarns, Crinkle Yarn.**)
- (iii) The heated yarn is passed over a knife edge (edge crimping). : In this method of texturing, thermoplastic yarns in a heated and stretched condition are drawn over a crimping edge and cooled. Edge-crimping machines are used to make Agilon yarns. (Also see **Textured yarns, Coil Yarn.**)
- (iv) The heated yarn is passed between a pair of geared wheels or some similar device (gear crimping). In this texturing method, yarn is fed through the meshing teeth of two gears. The yarn takes on the shape of the gear teeth. (Also see **Textured yarns, Crinkle Yarn.**)
- (v) The yarn is knitted into a fabric, heat-set and unravelled (knit-deknit). In this method of texturing, the yarn is knit into a 2-inch diameter hose-leg, heat-set in an autoclave, and then unraveled and wound onto a final package. This texturing method produces a crinkle yarn. (Also see **Textured yarns, Crinkle Yarn.**)

- (vi) Loops are formed in individual filaments by over-feeding into a turbulent airstream (air-textured). Also called Air Jet Method, in this method of texturing, yarn is led through the turbulent region of an air jet at a rate faster than it is drawn off on the far side of the jet. In the jet, the yarn structure is opened, loops are formed, and the structure is closed again. Some loops are locked inside and others are locked on the surface of the yarn. An example of this method is the Taslan process.

(Also see Textured yarns, Core-Bulked Yarn and Entangled Yarn.)

- (vii) Bicomponent Fibres (q.v.) are differentially shrunk.

(b) Processes (i) and (iii) above produce yarns of a generally high stretch character. This stretch character is frequently reduced by reheating the yarn in a state where it is only partly relaxed from the fully extended condition, thus producing a yarn with the bulkiness little reduced but with a much reduced retractive power.

(c) Fabrics that contain textured yarns have increased bulk, opacity, and moisture absorbency and improved thermal insulation properties with a warmer handle (q.v.); some textured yarns also confer extensible or “stretch” properties on fabrics made from them.

(2) Yarns that develop stretch and bulk on subsequent processing. When woven or knitted into fabric, the cover, hand, and other aesthetics of the finished fabric better resemble the properties of a fabric constructed from spun yarn. (Also see **Texturing**.)

(a) **Bulked Yarn:** Qualitative term to describe a textured yarn. A bulked yarn develops more bulk than stretch in the finished fabric. (b) **Coil Yarn:** A textured yarn that takes on a coil or spiral configuration when further processed. A coil yarn can be either a torque yarn or a nontorque yarn. A coil yarn can be formed by the false twist or edge crimp methods. Some bilateral fibres become coiled on further processing. (c) **Core-Bulked Yarn:** A bulky or textured yarn composed of two sets of filaments, one of which is straight to give dimensional stability and forms a core around and through which the other set is coiled or looped to give bulk. (d) **Crinkle Yarn:** A torque-free textured yarn that is characterized by periodic wave configurations. Crinkle yarns can be formed by the stuffer box, gear crimping, or knit-de-knit methods. (e) **Entangled Yarn:** A textured yarn of one variant that develops bulk by the air-jet texturing method. (f) **Modified Stretch Yarn:** A stretch yarn that develops more bulk than usual but less bulk than a bulked yarn in the finished fabric. (g) **Non-torque Yarn:** A yarn that does not rotate or kink when permitted to hang freely. A nontorque yarn may be the result of plying

two equal but opposite torque yarns. (h) **Set Yarn**: A textured yarn that is heat relaxed to reduce torque. Set yarns are not stretch yarns. (i) **Stretch Yarn**: Qualitative term to describe a textured yarn. A stretch yarn develops more stretch than bulk in the finished fabric. (j) **Torque Yarn**: When a torque yarn is permitted to hang freely, it rotates or kinks to relieve the torque introduced into the yarn during texturing.

Texturing: This term is used to include all process stages downstream of the actual texturing process. In the filament yarn sector these include: Intermingling: normally accomplished by air-jet techniques; Assembling: combination of multiple yarns with zero twist; Coning (winding): transferring the yarn onto a suitable carrier.

Texturing, air jet: The yarn is fed through a turbulent air stream, created by a jet. Usually the air is cold but occasionally hot air or steam may be used. The air jet causes entangled loops to be formed in the filaments. The resulting textured yarn is very bulky with permanent crimps and loops. Can be used for non-thermoplastic filaments.

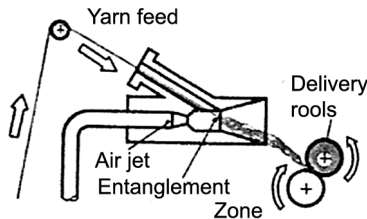

Texturing, False twist: The yarn is drawn through a heated zone whilst a predetermined, high level of false twist is inserted followed by cooling and untwisting. The heat softens the filament and the deformation imparted by the twist is permanently set during cooling. This is the most economical and hence most commonly used.

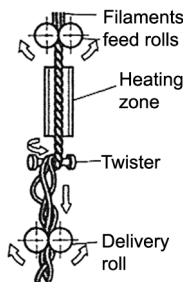

False twist texturing, schematic

Texturing, knit-deknit: The yarn is knitted into a tube on a circular knitting machine. The knitted fabric is heat set and then unraveled. The shape of the knitted loops is set into the yarn which develops a boucle' (crinkled yarn) appearance.

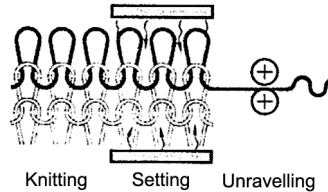

Texturing, stuffer box: The yarn is fed into a heated chamber where it is compressed. The zig-zag deformations are permanently set by subsequent cooling. The filaments can no longer lie close together so the yarn is bulky.

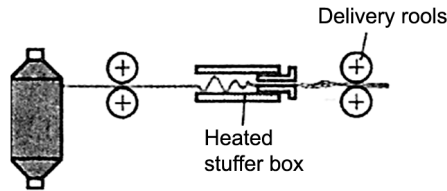

Texturing machines: Machines used for texturing. See **Texturing**.

Texturizing: The treatment of smooth filament yarns by permanently modifying the orientation of the molecular structure giving it more textile character. The changes to texturized yarns are: improved softness, volume and covering power, increased thermal insulation effects and an end-use required increase in elasticity. Thermoplastic filament yarns are particularly suitable for texturizing, i.e. yarns which are deformable under the influence of heat. These are mainly polyamide and polyester yarns.

Theoretical oxygen demand: Organic matter of animal or vegetable origin in waste water is generally a combination of carbon, hydrogen, oxygen and nitrogen. The principal groups of these elements present in the waste water are, as previously noted, carbohydrates, proteins, oils and grease and products of their decomposition. If you take any of these chemicals, ThOD will be the oxygen required for the complete decomposition (for example we take the case of Glycine ($\text{CH}_2(\text{NH}_2)\text{COOH}$ - in first step organic carbon and nitrogen are converted to carbon dioxide CO_2) and ammonia (NH_3) respectively. In second and third steps, ammonia is sequentially to nitrite and nitrate. The theoretical Oxygen Demand is the sum of oxygen required for all three steps.

Thermachrome process: (thermacrome process). Transfer print process for transferring paper prints in up to 4 colours onto synthetic fibre textile piece goods. The paper is printed with thermoplastic pigment print pastes which are transferred onto the textile material on passing a heated calender. This process is limited to the printing of labels and emblems.

Thermal blanket: A blanket woven so that cells or openings are created in the fabric so that air warmed by the body is trapped between the yarns, such as textured or leno weaves. The product can be napped or unnapped.

Thermal bonded batting: A textile filling material that contains low melting point fibres or polymers which, when heated fuse the batting material together.

Thermal bonding: See **Thermobonding**.

Thermal character: Apparent difference in temperature of the fabric and the skin of the observer touching it.

Thermal character: A tactile property of a textile material. It is the difference felt in the temperature of the material and the skin of the person touching it.

Thermal conductance: See **Thermal transmittance**.

Thermal conductivity: Time rate of unidirectional heat transfer per unit area, in the steady-state, between parallel planes separated by unit distance, per unit difference of temperature of the planes.

Thermal conductivity coefficient: See **Heat conductivity**.

Thermal conductivity of Textile materials: The technical thermal conductivity (λ) indicates the quantity of heat which flows through two opposite surfaces of a cube of 1m edge length per hour when the temperature difference between both surfaces is 1°C (→ Heat retention).

Thermal conductivity in W/m · °C:

glass	1.000
polyethylene	0.337
polypropylene	0.221–0.302
polyamide	0.209–0.290
m-Aramid	0.128
viscose (filament)	0.071
viscose (spun fibre)	0.063
asbestos	0.058
cotton	0.058
triacetate	0.058
acetate	0.050

polyester	0.046–0.081
wool, silk	0.046
air	0.025

Thermal drying of sludge: Heat can be used to dry wastewater sludge from 25 to 30% solids down to 90% solids. This minimizes the volume of the sludge. Drying is important prior to incineration of wastewater sludge, otherwise an external fuel source has to be used in the incinerator. A common technique is the use of a *rotary drum dryer*.

Thermal end point, in testing of thermal protective material: The crossing point of the sensor response on the recorder chart and the human tissue burn tolerance criteria overlay.

Thermal fixation See Dyeing. The use of dry heat to achieve a degree of permanence when applying colorants to textile materials.

Thermal resistance: The reciprocal of thermal transmittance.

Thermal resistivity: The reciprocal of thermal conductivity. Time rate of unidirectional heat transfer per unit area, in the steady state between parallel planes, per unit difference of temperature of the planes.

Thermal shock: Heat treatment at 200°C: I. Thermo-stabilization of synthetic fibres within 1 second. II. Rapid fixing of dyes (particularly of reactive dyes) during printing and continuous dyeing within 20–60 seconds.

Thermal shrinkage of textile yarns and cords: Contraction in length caused by heat.

Thermal stability: Stability of a material against temperature variations.

Thermal stability of dyes: Thermal stability when subjected to contact heat (ironing, fixing, drying), hot air (fixing, drying) and steam (steaming, decatizing, pleating).

Thermal stability of fibres: The impact of dry heat can bring about changes to fibre properties, the extent of which depends on the specific thermal stability of the fibre (heat stability) as well as the duration and temperature of treatment. As not only recognizable changes in chem. and technological properties, such as yellowing and greying, can be effected, it is advisable to check for other non-visible signs of temperature impact. This applies particularly to synthetic fibres (Softening range; Melting point).

Thermal transmittance: Time rate of unidirectional heat transfer per unit area, in the steady-state, between parallel planes separated by unit distance, per unit difference of temperature of the planes.

Thermal welding, in garment: Process by which flexible thermoplastic films as well as polyester needle felt and nonwovens are joined by welding

in garments. There are two main thermal welding techniques, namely the hot edge and hot air methods. In either case heat is supplied to the inside of the seam, to soften the thermoplastic components, after which the assembly is forwarded between two transport rollers where it is pressed and securely bonded. Starting, stopping and sharp corners are problematic.

Thermally bonded seam: A seam formed by heat and pressure.

Thermally Stabilized: See **Heat stabilized**.

Thermobonding: A technique for bonding fibres of a web with melt able powders or fibres, using infrared heating, hot air, or hot-calendaring. (Also see Bonding, Bonding with Binder Fibres and Powder-bonded non-woven.)

Thermochromism: Thermochromism is the term used to describe a change of colour as a result of a temperature change. Thermochromic dyes and pigments find application where this colour change is used to indicate a temperature change, for example in plastic strip thermometers, medical thermography and non-destructive testing of engineered articles and electronic circuitry. They may also be used in thermal imaging and for a variety of decorative or novelty effects.

Thermocolour markers: (temperature measuring pencil). Usually metal salts of complicated structure whose colour change at certain temperatures is based on oxidation or separation of water, carbonic acid and ammonia. Temperature measuring dyestuffs are also used as measures of heat radiation.

Thermofixation: Fixation of a dye on the fibre/fabric by application of heat only.

Thermoflush: Procedure for shortening the rinsing process for reactive dyeing by means of intermediate steaming several times, thereby reducing water consumption.

Thermofusion: Procedure whereby dry fleeces are completely bonded just by means of heating and subsequent cooling, e.g Spot-bonded nonwovens. The bonding of nonwovens of bi-components and other fibres or fibres mixtures is carried out using thermofusion systems, in every case using only hot air without steam or binders.

Thermogravimetric analysis: Analytical technique in which the rate of change in weight of a material undergoing continuous heating versus temperature is plotted. Used in analysis of polymers to provide information on such parameters as degree of crystallinity, glass transition temperature, thermal stability, etc.

Thermolabels: Self-adhesive thermos papers, coated with plastic, printed for 37.8–260°C and for five temperature ranges in 8 different arrangements (reaction speed: 2–5 seconds).

Thermometer papers: Paper strips or rolls with heat-sensitive covering (also self-adhesive) in series of varying heat degree gradations (37.8–254°C). At a certain temperature each strip changes its colour from white to black instantaneously and constantly at a quoted reaction speed of $\pm 1\%$ of the standard value.

Thermomigration: Desorption in the form of migration of dyes, particularly of disperse dyes on polyester under the influence of dry heat and in the presence of surfactants.

Thermoplast print blanket adhesives: Adhesives which are effective from a certain temperature and which are used in film printing where they are heated to the necessary temperature by means of heated rollers. Thermoplast adhesives, vulcanized in rubberized continuous printing blankets, allow the preheated fabric to be printed without glueing and washing using the preheated printing sheet to position the pattern for printing.

Thermoplastic: A textile that is deformable (but not changed chemically) by the application of heat and pressure. The salient feature is that the deformation can be repeated.

Thermoplastic resins: Fibres which demonstrate a softening range and are therefore thermoplastic. This property is also utilized during heat setting, See **Thermoplastics**.

Thermoplastics: Glass-like, hard solids that are thermoplastic are used in textile finishing for improving texture, draping properties, stiffness, durability, scrub-fastness and dimensional stability. See **Thermoplastics**.

Thermoplastics: (plastomers). Substances which are transformed reversibly into a plastic and therefore formable state when heated to a certain temperature (specific softening temperature). This does not involve any chemical change and the substance returns to its original hard or elastic state when it cools down. Thermoplastics can change from one state to the other as frequently as required.

Thermoset: A term used to describe a plastic that, once formed, does not melt when heated.

Thermosetting process: See **Thermo-set Process**.

Thermosol fixation: See **Dyeing, Thermal fixation**.

Thermosol pad steam process: A method which can be followed for dyeing polyester blended fabric. The fixation of disperse dye on synthetic fibre

(say, polyester) is done by thermosol method. The cotton dye is fixed by pad steam method. Since reduction clear before cotton dyeing is no possible in many cases a cotton reserve auxiliary is often used to avoid cross staining of disperse dye on cotton.

Thermosol process: See **Dyeing, Thermal Fixation.**

Thermosol stiffening: Fabric stiffness and stiff texture brought about by Thermosol fixation particularly of knitted fabrics in textured yarns which can be removed by subsequent wet treatments or on the mechanical breaking machine.

Thermotropic polymer: Polymer that exhibits liquid crystal formation in melt form.

In thermotropic polymers there must be a balance between having the necessary degree of molecular perfection to preserve the liquid crystal formation and the amount of imperfection to permit melting at workable temperatures. These polymers give high-modulus, highly oriented, extrusion products.

Thermoweave process: Yarn or filament fibre used for producing carpet yarns by the bonding process are rolled and deep-frozen. This roll is sliced and the slices are bonded onto an underlay material.

Therm-set Process: Permanent-press process for cotton and polyester/cotton. The textiles are impregnated and dried with DHDMEU and a weak resin finishing catalyst (glycolic acid) before crosslinking and after-curing with a 1% magnesium chloride hexahydrate catalyst solution to fix pleats and creases in a pressing process.

Theta temperature: A temperature at which a polymer of infinite molecular weight starts to precipitate from a solution.

Threading cross: is the "x" formed by alternate warp ends because they each take a different path over and under a pair of pegs on the warping board: over/under for one end and under/over for the alternate end. If the openings created by the pegs are maintained when the warp is removed from the warping board, the crossing of the threads is also maintained and keeps them from shifting their order.

Terry towel: A textile product with end hems or fringes and side hems or selvages which is made with loop pile on one or both sides generally covering the entire surface or forming stripes, checks or other patterns.

Thibet: An all-wool stout dress goods or coating, well felted and given a smooth and soft face, showing an indistinct twill. Often made with a cotton warp. It comes usually in solid piece dye or in mixtures.

Thibet Shawl: Made in France of wool and waste silk with various coloured patterns woven into.

Thick and thin places (major defect in fabrics): Places in the fabric where, for 25 cm. (1 in.) or more the count varies more than a specified percentage from the specified count.

Thick and thin places (minor defect in fabrics): Places in the fabric where for less than 25 cm. (1 in.) the count varies more than a specified percentage from the specified count.

Thick filling: See **Coarse pick**.

Thick place, in fabric: Yarn defect characterized by a diameter greater than that of the adjoining segments and extending for 6 mm. (1/4 in.)

Thick place: A textile that is deformable (but not changed chemically) by the application of heat and pressure. The salient feature is that the deformation can be repeated.

Thick weft: See **Coarse pick**.

Thick-and-thin yarn: A novelty yarn of varying thickness.

Thickeners: Usually water-soluble, swell able substances with colloidal character which are used in their thickened state as thickeners for printing with aqueous solutions of dyes, pigments and the like are used to prevent running (flowing) of the printed pattern on textile material (Print paste application).

Thickener, Natural: (1) *Plant-based products:* Starch, particularly wheat starch, swelling starches, roasted maize starch, types of gum (See Vegetable gums) such as gum arabic, industrial and synthetic gum; Locust bean flour, Tragacanth, extracts of lichens, mosses, types of seaweed, such as: Alginates; Agaragar, carrageen. (2) *Animal products* Albumen; Gelatine; Casein; Glue. (3) *Mineral products (earth)* China clay; Kaolin; Colloidal solution.

Thickener, artificial: (modified natural products): Cellulose derivatives; Starch ethers; Starch esters; Ethoxylated or monoacetic converted meal.

Thickener, synthetic: (synthetics and synthetic resins): particularly polymerisates on the basis of polyvinyl alcohol, polyacrylate, also chlorinated rubber.

Thickener, emulsion: Used for pigment printing, in a oil -water emulsion.

Thickness of textile fabrics: The distance between one surface and its opposite.

Thickness: The distance between one surface and its opposite; the distance between the upper and lower surfaces of the material, measured under a specified pressure.

Thigh girth, in body measurements: The maximum circumference of the upper leg close to the crotch.

Time-to-break: The time interval during which a specimen is under prescribed condition of tension and is absorbing the energy required to reach the maximum load.

Thin end: See **Fine end**.

Thin filling: A weft yarn smaller in diameter than normally being used in that fabric..

Thin filling bar: See Fine filling bar, Filling bar, fine.

Thin pick: A yarn defect characterized by a segment that is substantially (at least 25 %) smaller in diameter than the average diameter than the average diameter of the yarn.

Thin place: A yarn defect characterized by a segment that is substantially (at least 25%) smaller in diameter than the average diameter of the yarn.

Thin place: A prominent band (q.v.) in which there is a decrease in the pick density of a woven fabric or in the stitch density of a knitted fabric, compared with that of the normal fabric.

Thin shade: Term used particularly when sampling dark colours to describe missing Bloom or character.

Thin Spot: See **Crack mark**.

Thio: Greek. "Thios" = Sulphur.

Thiobenzanthrone: Anthraquinone dyes of the Benzanthronoid vat dyes group. Condensation of 3-mercaptobenzanthrone with chloroacetic acid, fusion with potassium hydroxide and oxidation.

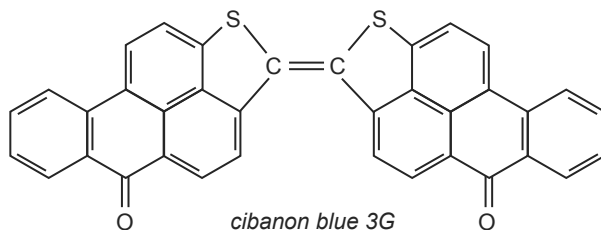

Thiocarbamide: Thiourea.

Thio compounds: (Gk.: thios = sulphur). They are derived from oxygen compounds whose oxygen was substituted by usually divalent sulphur. Examples are sulphurous acid ($H_2S_2O_3$) and sodium thiosulphate ($Na_2S_2O_3$).

Other thio compounds are, for example, thioethers (alkyl sulphides) of the type $H_3C_2-S-C_2H_5$ and thiophenols of the type $(C_6H_5)SH$.

Thiocyanates: SCN-type compounds, e.g. thiocyanic acid HSCN and its salts, thiocyanates, such as potassium thiocyanate and KSCN. Thiocyanates are usually colourless and easily soluble; only lead thiocyanate is difficult to dissolve; copper, mercury and silver thiocyanates are not soluble. With iron(III)-chloride solution ($FeCl_3$), soluble thiocyanates result in a typical blood-red colour (iron detection).

Thiocyanate/tin discharges A very aggressive discharge system Tin salt discharges which are carried out under stringent conditions.

Thiodiethylene glycol (thiodiglycol): $S(CH_2-CH_2-OH)_2$. Substance with a molecular weight of 122 and b.p. at $282^\circ C$ which is used as a dye solvent and fixation accelerator for vat printing. Contact with hot hydrochloric acid results in the formation of mustard gas: $S(CH_2-CH_2-Cl)_2$.

Thiodiglycol: Also called thiodiethylene glycol or 2,2'-thiodiethanol Thiodiglycol is sometime used to increase solubility of acid dyes, particularly for making printing pastes. It is very hazardous if mixed with hydrochloric acid. It is difficult to obtain, and there may be restrictions on its sale in some countries.

Thioethers (alkyl sulphides, type: $R-S-R1$) alkyl-substituted Mercaptans and/or dialkyl derivatives of hydrogen sulphide such as dimethyl sulphide (CH_3-S-CH_3) or methylethyl sulphide ($CH_3-S-C_2H_5$). They are used as the basis of textile auxiliaries. Thus, for example, the thioether, dodecylmethylethyl sulphide, results in the corresponding cationic sulphonium compound.

Thioglycolate number: Test for evidence of damage to wool (particularly in the case of acid damage) in which the solubility of wool in alkaline thioglycolate solution is determined and quoted as a percentage. Untreated wool has a thioglycolate number of 15.9; after treatment with sodium carbonate: 0.00–6.8; with H_2O_2 : 18.7–25.8, with H_2SO_4 : 27.0–89.5. Determination of the thioglycolate number (based particularly on peptide splitting) is a valuable supplementation of alkali solubility determination (specifically on initiating cystine splitting).

Thionyl chloride: An acid chloride of sulphurous acid: $SOCl_2$; colourless liquid which produces smoke when exposed to air, smells suffocating and is strongly light-refracting. It splits in water to HCl and SO_2 . Thionyl chloride is used among other things for providing evidence of polyvinyl alcohol sizes; pass steam through of an aqueous fibre extract, after cooling add thionyl chloride until yellow coloration indicates total solution has taken place:

change of colour to black-brown, then black precipitation as positive evidence for formation of characteristically coloured polyenes.

Thiourea: Sulphonate urea, sulphonate carbamide, thio carbamide). $\text{H}_2\text{N}-\text{CS}-\text{NH}_2$; molecular weight 76, density 1.40. Thiourea is used as a softening agent to increase the durability of heavy silk; for preventing over-oxidation when developing vat leuco ester dyes; as a vulcanization accelerator; as a padding auxiliary. Thiourea is used less and less frequently for printing polyamide with acid and substantive dyes. As a stable reducing agent in stripping and discharge effects on dyeings formamide sulphinic acid is used from the oxidation of isothiourea.

Thiourea Dioxide: Thiox; a reducing agent used in discharge, stripping and vat dyeing; also called formamidine sulfinic acid or thiox; sometimes abbreviated TUDO; Colour Index Reducing Agent 11 Thiourea dioxide is popular discharge agent. It can also be used for bleaching wool, since will not damage the fibre like chlorine bleach will. Thiourea dioxide is considered to be safe, from a health risk point of view. Thiourea itself, which may exist in very minute proportions in thiox, is known to be a carcinogen. Extra care in handling is warranted. Thiox powder is flammable. Carboxymethyl starch (Monagum) is suitable as a thickener if required.

Thiox: Thiourea Dioxide. A safe replacement for sodium hydrosulfite in vat dyeing, discharge printing, and general colour stripping on cellulose and protein fibres. Good shelf life if stored in a dry location. Five times stronger than sodium hydrosulfite.

Thong hole, in Zipper: The opening at the end of a pull.

Thornproof tweed: A wool type suiting fabric produced from highly twisted yarns containing thorn proof tweed that are closely set to give the cloth a firm and hard handle. Two fold yarns consisting of differently coloured singles are commonly used.

Thousand-point roller: (kiss roller). Has fine point engraving and is used for Kiss roll padding on the printing machine, i.e. for transferring a fine liquid film that may contain additional chemicals and dyestuffs. It is used for pre-moisturizing less absorbent fabrics, for dyeing one side of a fabric and for ludigol treatment, etc.

THPC: Abbreviation for tetrakis-hydroxymethylphosphonium chloride which is used for washing- and dry-cleaning-resistant Flame-retardant finishing of cotton. Originally this finishing process was carried out using a nitrogen methylol compound, such as trimethylolmelamine, under dry crosslinking conditions. Nowadays the finishing process is usually carried out using THPC

urea or substituted melamine products and subsequent gas- or aqueous NH₃ treatment.

THPOH: Abbreviation for tetrakis-hydroxymethyl phosphonium-hydroxide which is used for flame retardant finishing. THPOH is volatile at higher temperatures and the flame-retardant effect can therefore be partially reduced during machine stops in the finishing process.

THPOH-NH₃-Finish: Permanent Flame-retardant finishing for cotton and rayon staple fibre with THPOH or THP salts, such as, for example, THPC.

THPS: Abbrev. for tetrakis ammonium-hydroxymethyl phosphonium sulphate which is used for Flame-retardant finishes of cellulose and cellulose/ polyester mixtures with a minimum proportion of 65% cellulose. The application process involves impregnation, which is carried out first, followed by drying, condensation and after-washing. The finish withstands 50 household washes. When used after the condensation process with the addition of finishing agents it results in a crisp, stiff handle.

Thread: (1) (a) The result of twisting together, in one or more operations, two or more single, folded or cabled yarns (see **under yarn**). (b) A product as defined in (a) above and intended primarily for sewing purposes and known as a sewing thread. (c) A component of silk yarn, and that is the product of winding together, without twist, a number of baves (q.v.), e.g. a 3-thread silk yarn is the result of folding three such products together. 1. The term “thread” is frequently used to describe single yarns.

(2) The term “thread” is also used in such expressions as “threads per unit length”, irrespective of their nature.

Thread break, in sewn seams: A mode of failure in sewing evidenced by rupture of the sewing thread.

Thread-by-thread: (Fr.: fil à fil), fabric in plain weave 1/1 or twill 2/2 which is characterized by a special pattern achieved by alternate weaving of light and dark yarns in warp and weft directions. Fil-à-fil fabrics created in this manner are also known as “Pepper and salt articles”, black and white and grey-white in point patterns. Thread-by-thread fabrics are used for manufacturing outer clothing.

Thread count: Number of threads in warp or weft direction of a screen gauze per cm (= fabric-no.) or per inch (mesh number).

Thread Fabric: Plain woven, very strong, heavy cotton fabrics, made with ply warp and single filling, the latter placed very far apart from each other. The fabric is used for foundation for tires.

Thread holder: The device on which sewing thread yarn is wound so that it can be transported to and run off smoothly at, the sewing operation. It may be in the form of cone, spool, or tube.

Thread, element attaching, in Zippers: The thread that secures the continuous monofilaments to the tape.

Thread, gut: See **Stuffer yarn, Yarn, Stuffer**.

Thread per sq. cm.: The sum of the number of warps threads per centimetre and the number of weft threads per centimetre in a woven fabric.

Thread per unit length: The number of warp threads (ends) or the number of weft threads (picks) in a specified length of fabric. (a) The unit of length is usually taken as the centimetre, but with fabrics that have less than 10 threads per centimetre, it is advisable to use a unit length of 1 decimetre (10 cm). (b) With fabrics that have more than 10 threads per centimetre, the actual count may be taken over 2 cm, 3 cm or 5cm and the result given by calculation in threads per centimetre. (c) Counting may be done at the following stages of manufacture:

- (i) Finished: The count is taken when no further processing in the piece is prescribed. In all cases, the condition of the fabric at the time the count was taken should be noted.
- (ii) In the Loom: The position of the count should be agreed on. It is usually taken between the fell of the fabric and the take-up roller, with the fabric under weaving tension.
- (iii) Loomstate :The count is taken after the fabric has been removed from the loom and relaxed from weaving tension, but before it is subjected to any further treatment that may modify its dimensions.

Thread out: See **End out**.

Thread Size: Many different thread size systems are used in the world for sewing threads. Generally, the thread size refers to the diameter or thickness of the thread. The Tex Size system can be used universally for all of its thread products. Other thread size systems used include the Cotton Count System; the Metric System, the Denier System and the Silk System used for both Silk and Mercerized Cotton threads.

Thread, Element attaching, In Zipper: Obsolete term.

Thread, silk, for silk threads: A synonym for ply, e.g. 2 thread and two ply, may both be used to describe a silk thread.

Thread sewing: A flexible small diameter yarn or strand usually treated with a surface coating, lubricant or both intended to be used to stitch one or more pieces of material or an object to a material.

Thread-up: Fabric path or thread-up in a Steamer.

Threading hook: A threading hook (or heddle hook) is a long slender piece of flat metal with a handle at one end and a tight curve at the other to catch and pull warp threads through the heddles.

Threading, in weaving: The threading is the order in which each warp end passes through a heddle on a specific shaft.

Treadls: The treadles are pedals attached to shafts to make them go up and/or down in all of the combinations required by the weave structure.

Threeply carpet: (Scottish carpet). Reversible carpet made of three interwoven fabric layers.

Three-Quarter: Goods Measuring 27 inches in width.

Three-quarter cloths: Shorn soft and semi-dull brushed fabric (woollen cloth), belonging to the class of so-called fine cloths, in linen weave, not too heavy, i.e. below 400 g/m².

Three-roller yarn: Generally cotton or viscose spun yarns (as opposed to two-roller yarns) from so-called three-roller spinning which works on the principle of the stretching process (3-cylinders as pre-spinning machine, also known as flyer, for stretching, twisting and parallel alignment of tow).

Three-stage drip-in dyeing process: This is used for reactive dyes in exhaust dyeing processes. Especially recommended for jet dyeing machines. Constant temperature of 60°C. Addition of dye in two stages and of trisodium phosphate in three stages.

Threaded-Roll Process: A high-speed method developed by Celanese for converting crimped continuous filament tow into highly bulked, uniformly spread webs of up to 108-inch widths. The webs are useful in a variety of products, such as cigarette filters, sleeping pillows, and battings.

Threadbare: A fabric which lost all its nap and the foundation threads are visible.

Threadlines: The fibre lines of a manufactured fibre in extrusion or subsequent processes.

Thread out: See **End out**.

Threadup: The process of directing or threading fibre or fabric through all machine positions to start or restart a process, or the configuration resulting therefrom.

Thready: Fabric finished to show every thread on the face.

Three-Bar Fabric: A tricot fabric made on a machine equipped with three guide bars.

Three-Dimensional Weaving: To produce three-dimensional textiles, yarns are simultaneously woven in three directions (length, width, and thickness) rather than in the conventional two. The types of structures that can be produced fall into four broad classes: (a) contoured fabrics, (b) expandable fabrics, (c) interwoven fabrics (Also see Double weave), and (d) contoured interwoven fabrics.

Threeply Carpet: (Scottish carpet). Reversible carpet made of three interwoven fabric layers.

Threshold effect: Delayed precipitation of low solubility compounds that is shown by polyphosphates and also by complex phosphates in similar fashion.

Throats, In Zipper: The two opening in a slider that receive the stringers.

Through and Through: Wool fabrics, the face and back of which are made alike.

Throughput: The amount of raw material processed in a specific time. This is the actual amount, not a percentage.

Throw: A removable unfitted protective textile cover, used over upholstered furniture.

Throwing: The operation of doubling or twisting silk or manufactured filament yarns.

Thrown silk: See **Silk, thrown**. Same as reeled silk, and is made into organzine or tram.

Thrown Singles: A single silk filament “thrown” with about 15 turns to the inch.

Throwster: A company that specializes in putting additional twist in yarn. More recently, the term also applies to a company that specializes in texturing yarns.

Thrum: A waste length of warp (yarn) or of fabric, or both, formed during the preparation of loom for weaving. (a) A thrum may be formed as follows:

- (i) During the adjustment of a loom at the commencement of the weaving of the warp. When the loom is correctly adjusted, the portion of the warp that contains picks inserted for testing the adjustment of the loom mechanism is cut off.
- (ii) During warp replenishment in a loom. The old warp is twisted or knotted to the new warp and, if the new warp is drawn through by weaving, the point in the woven fabric at which the twisted or knotted warp ends occur is called a “through” because the fabric is cut through to remove the thrum containing the imperfect fabric formed by the twisted or knotted warp ends.

(iii) During loom operations away from the loom. In the above cases, a thrum consists of portions of the old and the new warp ends twisted or knotted together.

(b) A thrum may also be: (i) A length of warp ends cut from the warp for the purpose of evaluating the percentage of applied size; and in repairing end-breakages in the warp concerned; (ii) Any loose end(s) of warp; (iii) A bundle of coarse yarns tied together by twine for use in making a mop.

Thunder and Lightning: Same as Oxford gray.

Tiaoyong: Warp printed Chinese silk plush.

Tibet Wool: (Tybet). Term used for unmilled fabrics sorted as Rags and used to produce Reclaimed wool of quality category II.

Tibetan cashmere: is derived from the Tibetan goat which lives in Tibet and is closely related to the cashmere goat. Tibetan cashmere is somewhat rougher and a little more glossy in appearance. Production, properties and utilization are similar to cashmere. Animal hair fibres.

TIC: Abbreviation for “Total Inorganic Carbon”; value used in Biological waste water treatment, quoted in mg/l waste water or in mg carbon/g substance.

Ticket number: The tex ticket number assigned to a sewing thread to designate its approximate linear density of the sewing thread.

Ticking: A very strong, closely woven twill fabric. It is stiff and recognised mainly by the fact that it is woven in narrow stripes of a colour and white, but it can be plain. It is usually made of cotton, although sometimes linen is added. The coarsest ticking are called straw tickings because it was used as covers for straw filled mattresses. A characteristic construction is 64×50 in 2/1 twill with 12s warp and 14s filling. Regular tickings usually woven with 2/2 twill with a characteristic construction of 80×90 with 12s warp and 16s filling. Finest ticking usually called sa teen ticking are made with the 5 harness warp flush satin weave. The construction will be around 100×50 with 14s warp and 20s filling. Not an attractive fabric, normally used loomstate, although it occurs occasionally as a fashion fabric for womens jackets and trousers. Main use of tickings are mattress and furniture covers and as backings for rubberised materials.

Ticking, nankin: Same plain weave fabrics which has the same type uses are sometimes called Nanking tickings. It is made with unbleached yarn in the warp and solid coloured yarn in the weft. A typical texture is 80×80 with 22s warp and weft.

Ticking: Densely woven, generally striped patterned linen, cotton or half linen fabrics in twill weave. See **Drill fabrics, Ticking, nankin.**

Tie: (tying). This is carried out for patterning of: – warp or weft threads (→: Ikat; Kasuri dyeing), – fabrics (See: Bandhana; Plangi; Shibori technique). Tying is carried out by binding with threads which prevents penetration of the dyes on subsequent dyeing. Machine tying of yarns has also been carried out for some time using wires which give reproducible patterning.

Tie & dye: A technique of dyeing to produce unique patterned effects by tying and or knotting the material before immersion into a dyeing bath, to resist penetration of dye. Fabrics are made into tiny puffs with some object inside and tied with a waxed thread wherever the dye has to be prevented. The fabric is immersed in the dye solution. If two or more colours are desired the thread is removed and the fabric retied. After drying the object is removed. Other methods of tie and dye include folding the fabric and stitching it and pulling the threads to draw the fabric to resist the dye from penetrating into the fabric, called as tritik. Tie & dye fabrics are quite popular in apparel and home furnishings. See **Bandhani**.

Tie cloth: Any soft or crisp fabric suitable for men's ties or cravats, including tie silk and Faille, Pongee, in twill weave, acetate, polyester or silk fibres.

Tie-back: See **Sticker**.

Tie-up: The tie-up shows the shafts that must be raised and/or lowered by each treadle to make each shed required by the weave structure.

Tieing technique: Fabrics (and in many cases finished items of clothing, particularly T-shirts) are tied in a certain way along the lines of tie-dyed batik or tie dyed technique prior to dyeing resulting in interesting patterns. Dependent on the type of Tie, effects known as the "Mukeka Mutono Special", the "Grill" or the "Tortoise" are given.

Tier drier: Driers through which textiles are moved in several tiers.

Tight end, in woven fabrics: A yarn which was woven under excessive tension or has shrunk more than a normal amount.

Tight filling: See **Tight pick**.

Tight end: A warp thread or part of a warp thread that has less crimp in the fabric than have the adjacent normal ends. This may be owing to weaving under greater tension or to abnormal stretching of the yarn during some process prior to weaving. It may be caused by excess moisture, e.g. during winding, and consequent contraction during finishing.

Tight pick, in woven fabrics: A filling yarn which was woven under excessive tension or has shrunk more than a normal amount, which may cause puckering at the junction with normal picks giving a wavy or ruffled surface appearance.

Tight pick: A weft thread or part of a weft thread that has less crimp than have the adjacent normal picks. This may be owing to a weft yarn having been inserted under greater tension than that imposed on the other weft yarns, or to the relaxation of a weft yarn subsequent to insertion, or to abnormal stretching of a yarn during some process prior to weaving. It may also be caused by the presence of excess moisture, e.g. during winding, and consequent contraction during finishing. (See also **shiner**.)

Tight selvedge, in woven fabric: Self descriptive. Selvedge yarn shorter than warp yarn in the body of the fabric.

Tight spot, in textured yarn: Faults in fabric twist textured yarn consisting of small isolated regions of twisted yarn each containing a few turns of twist.

Tight threads: Warp or weft threads caused by too great a tension (usually due to the state of humidity during weaving so that these threads in the fabric shrink during drying) which can result in unevenness in fabrics which has to be eliminated by stitching or at least improved.

Tight/slack thread: A thread or pieces of thread which are tighter or slacker than the other pieces/threads.

Tight twist end: A single end with higher than normal twist.

Tightness factor: See **Cover factor**.

Tile (or brick) repeat: A simple repeat where the motifs are repeated rather like a simple brick wall pattern. The second row slides halfway across, in a width ways direction.

Tillandsia fibre: (1) (American moss, tree hair, Louisiana moss). This is produced from the jointed and branching stem of the rootless tendril creeper (tree parasite) whose three metre long stem hangs from branches in beard-like fashion. The unpeeled raw fibre is grey-greenish white; the peeled pure fibre is brownish black and is often dyed black artificially. The fibre bundles are separated using boiling sodium carbonate solution. Tillandsia fibre is characterised by great durability and strength and is often used as a substitute for horse hair and as upholstery material. (2) Kenaf.

Time of half-dyeing: Time in minutes which is required for 50% of the amount of a certain dye contained in the liquor to be absorbed by the fibre. Unsuitable as a basis for selection of combination dyes for cationic dyes on polyacrilonitile. Compatibility value is better suited.

Time management: Making the best use time to achieve what is necessary.

Time-to-break: The time interval during which a specimen is under prescribed condition of tension and is absorbing the energy required to reach maximum load.

Timing, Advanced in knitting: is the reverse of delayed timing. The cylinder loops rob from the dial, producing tighter dial loops; advancement can only be about one needle.

This type of timing is sometimes used in the production of figured ripple double jersey fabrics, where selected cylinder needles can rob from the all knitting dial needles

Timing, Delayed, also called rib or interlock timing the dial knock over occurs after about four cylinder needles have drawn loops and are rising slightly to relieve the strain.

Timing, in knitting: The order the needles in the dial and cylinder go through the knitting cycle in relationship to one another. The cylinder needles that correspond to dial needles may go through the knitting cycle before or after the dial needles.

Timing, Needle: is the relationship between the loop-forming positions of the dial and cylinder needles measured as the distance in needles between the two stitch cam knock-over points.

Timing, Synchronized: also known as point, jacquard and 2×2 timing, is the term used when the two positions coincide with the yarn being pulled in an alternating manner in two directions by the needles, thus creating a high tension during loop formation.

Tin chloride: (tin (II) chloride, read tin two chloride) SnCl_2 ; also called stannous chloride 2. Formerly, tin (II) chloride was often used as a reducing agent for discharge printing. In most cases sodium formaldehyde sulphonylate or zinc formaldehyde sulphonylate has replaced it in modern processes. It still finds some application for discharge on acrylic fabrics. It is also used as a mordant with some natural dyes.

Tin salt discharges: Reductive discharges with tin(II)-chloride. No longer generally used on cellulose fibres. Was used frequently prior to introduction of sulphonylates. On acetate and triacetate. See **Acetate fibres in discharge printing.**

Tinsalt weighting: Weighting of silk using TinSalts. The disadvantage is the strength reduction of silk at higher weighting.

Tinsel: Very narrow, flat strips of gold, silver or other metal, used as cover for core yarn or used directly for embroidery and brocades.

Tint: (verb) To mix white pigment with absorbing (generally chromatic) colorants.

(noun) The colour produced by mixing white pigment with absorbing (generally chromatic) colorants. The resulting mixture is lighter and less saturated than the colour without the white added.

Tinting Of Bleach Goods: (blueing dyes). Blue, red and violet dyes for application during Tinting of bleached goods. In small quantities tinting dyes achieve a significant increase of the white appearance both with optically-brightened material and with optically brightened ground white. Dyes used for this purpose are as brilliant as possible in order to reduce the absorption range for as narrow a band as possible. On the other hand dull tinting dyes, such as mixtures of a brilliant dye with grey, reduce the brightness unnecessarily.

Tip Definition, in carpet: Visible single ends of cut yarn.

Tip Effects: Tip effects on pile fabrics; vivid patterned woven fabrics or furs are produced by surface coloration of the extreme tips of the pile. See **Emboss printing**.

Tip printing: Only the surface of the embossed sites of the fabric is dyed on the embossing calendar directly after embossing, namely by means of an overdyeing unit situated on the cloth delivery end. An intensified relief effect is relatively easily obtained by this process. Localized tip-dyed effects can also be produced with suitably engraved rollers. See Embossed printing.

Tipping, wool: See **Wool, tipping**.

Tippy Dyeing: The tips of woollen fibres are exposed to light, weather and environmental influences during their growth. For this reason tips and root-ends dye differently (Skittery dyeing wool). The extent of the colour difference between tips and root-ends depends not only on the wool but also on the category of dye and the process used.

Tip-Sheared Carpet: A textured pile carpet similar to a random-sheared carpet, but with a less defined surface effect.

Tiraz: Very rich Arabian silk fabric with names of Sultans and other prominent people interwoven; used as material to write on in medieval Europe, when it was solid coloured.

Tiretaine Serge: Usually made with linen or hemp warp and inferior woollen 'filling, occasionally also of all wool. It is a strong, stout fabric, finished either pressed or with the nap raised; used for working dresses in France.

Tirtey: Reasonably-priced and generally durable fabrics which consist in the warp of fine-threaded strong cotton or rayon staple fibre yarns but of carded yarn (often reclaimed wool with the addition of cellulose) in the weft. Finished with either Melton or brushed effects.

Tissue: The term used to describe a light transparent cloth in any fibre. It usually means one that has body and is not soft and floppy.

Tissue: (1) A general term used especially in Great Britain for woven fabric, but usually applied to thin, sheer fabrics. The term is also used as an adjective to denote thinness and sheerness. (2) A term applied to 15th century cloths of gold and medieval silk damask with gold and silver threads interwoven. In Jacquard weaving today, tissue is decorative yarn added to fabric in addition to base fabric. Derived from the French "tissue" which means fabric.

Tissue Taffeta: The finest, lightest taffeta. It is most transparent and normally only used for underwear or for lining fine garments.

Tissute: French serge, having eight ends and four picks in a repeat.

Tissuti: See **Amamee**.

Titan Braid: A coarse, flat military braid made of coarse long wool. Called also Hercules braid.

Titanium dioxide: Titanium(IV) oxide, TiO_2 ; molecular weight 70, density 3.8. The white powder is not soluble in water or dilute acids. It is used as a white pigment with a high covering capacity in paint coatings and as a matting agent for fibres, in paint and frosted glass. It is usually supplemented by calcium or barium sulphate. A compound (TiO_2) that occurs naturally in three different forms (rutile, anatase, and brookite).

Titer: See **Density, linear**.

Titration: is used for quantitative content determination of a solution to be tested by means of a normal solution of known content which flows into it (using a burette or a pipette), Normal solutions. The end of the reaction (neutralisation, oxidation, reduction, precipitation) is shown by the colour change of an added indicator. The content calculation is made from the relationship between the utilized quantity of solution to be tested and the consumed normal solution.

Titre: French term for the size of the silk thread. It is expressed in deniers in Europe. The international denier being the weight of 10,000 meters of silk yarn. The titre in England and in the United States is expressed in the weight of 1,000 yards in drams.

Titrimetry: See **Titration**.

Tjap print: Japanese stamp batik which is carried out using so-called tjaps, stamps made of copper strips (block fastened). The process is more rapid than the free-hand method using the See **Tjanting**.

TLV: Abbreviation for Threshold Limit Value.

TLV values Maximum threshold limit values in the workplace are the highest permissible concentrations of substances such as gas, steam or other airborne substances which, on the the basis of current knowledge, do not impair the health of employees in the case of repeated long-term exposure and likewise do not place undue strain on them (BAT value).

Tobacco cloth: See **Cheese cloth**. A thin, lightweight, open cloth used to shade and protect tobacco plants.

Tobines: Stout, strong, twilled silk dress goods in France.

TOC: Abbrev. for Total Organic Carbon.

Tochirimen: A cotton crepe made in Japan.

TOD: Abbrev. for Total Oxygen Demand = total content of oxidisable substance (inorganic and organic substance, including nitrogen and sulphur) which is quoted in mg oxygen/l waste water or in mg oxygen/g substance.

Tod: Equal to 28 pounds; used for measuring wool and top in England.

Toe closing: In knitting hosiery, this term refers to closing the toe opening. It may be knit closed, or in tube hosiery, sewn closed.

Toga: Outer robe of the Roman ruling class; an oval woollen cloth folded lengthways and draped artistically around the body.

Toggle, in button: A clip used to fasten a staple button to the flexible substrate.

Toile: This is the French for fabric. (a) A broad term describing many simple plain weave twill fabrics, especially those made from linen. (b) Sheer cotton and linen fabrics.

Toile d'Alsace: Fine thin French linen dress goods, made white or printed.

Toile d'Araigner: Open work French woollen dress goods.

Toile Bleue: Fine linen dyed light blue.

Toile a Bluteau: Sort of bolting cloth in France.

Toile de soile: Warp and weft of schappe twisted thread; a soft rather matt fabric.

Toile a Chapeau: In France highly glazed, and stiffened linen or cotton fabric; used for hat shapes.

Toile de Chinese: Damask table linen in France.

Toile Ciree: Fine French oilcloth.

Toile de Coffre: French household linen of good grade.

Toile Colbert: Loosely woven cotton or woollen canvas; used for embroidery.

Toile De Coton: Light dress goods of mixed cotton and linen with woven stripes and printed patterns.

Toile E cru: Unbleached linen.

Toile d'Emballage: Packing cloth.

Toile d'Embourrure: Linen cloth used as lining.

Toile de Frise: A very fine Holland linen.

Toile de Halles: Stout, unbleached linen.

Toile de Laine: Very soft, light weight, French dress goods, made of merino wool, usually all black, in plain weave.

Toile de Lille: Fine French table linen, often made with coloured stripes.

Toile de Mulquinerie: In France name for the finest lawns, cambrics, linen batiste, etc.

Toile du Nord: French gingham, made in checks with a smooth finish.

Toile d'Orange: Fine stout calico made in France.

Toile d'Ortie: Sort of French batiste made of nettle fibre.

Toile d'Ourville: Unbleached French canvas.

Toile de Religieuse: French for nun's cloth.

Toile Satinee: Very soft and thin 'French cotton cloth, in plain colour or printed.

Toile de Saxe: Plain woven French dress goods, made with cotton warp and worsted filling.

Toile de Sion: Medieval printed linen.

Toile de Sole: Very light, plain woven silk fabric; used for scarfs.

Toile a Tamis: Blue buckram, with prominent stripes.

Toile a Veste: A striped or checked, or solid coloured, plain woven cotton or linen fabric, used for lining in France.

Toile de Vichy: Light French linen dress goods in pink and white or blue and white stripes.

Toile Victoria: All-worsted, light French fabric of plain weave in the 19th century.

Toile a Voile: Sail cloth.

Toile de Vosges: Coarse, stout, plain woven cotton fabric, made in France for the African markets.

Toilet Cloth: Another name for quilt.

Toja: Same as Bun ochra.

Tokhfil: Two-ply silk thread, reeled from spools by the natives in Central Asia; used for filling.

Tol: A fine and narrow strip of cloth often woven with complicated patterns. Made by the natives of the Caroline Islands and used as girdle, apron, etc.

Tolerance: The amount of acceptable difference between a known correct standard (usually the customer's specifications) and a set of measured samples.

Tolerance, in mathematics: Prescribed limits of variation for specified.

Tolerances, when included in a contract: The limits to which the average (or other specified) value observed for a specific characteristic of a lot of material must confirm to constitute a valid delivery. The observed values must have been obtained by specified test methods on sample representatives of the materials to be tested.

Tolotzin: White bast fibre, yielded by the *Heliocarpus* tree in Mexico.

Tonder Lace: (1) Danish bobbin lace originated in the middle of the 17th century. Early specimens show Flanders influence with trolley latter specimens have fine Malines foundation with various running designs; (2) Drawn work made of fine cambric.

Tone-in-tone dyeing: (1) "Same shade" dyeing in the sense of a single colour shade (Self shade) with mixed-fibre articles and yarn mixtures; both components of the mixture demonstrate the same colour shade. (2) "Colour shift". An example is the Multicolour process in which only one type of fibre is used but of which a section has assumed greater capacity to absorb or to resist dye as a result of appropriate pretreatment. The dyeing process results in different colour shade intensities with the same colour shade. (3) Dyeing of ombre or shaded effects.

Tonga Salempore: A loosely woven, netlike cotton fabric of plain blue colour, made with wide white headings and a stiff finish; used for garments by the natives in South Africa.

Tongue tear strength: The average force required to tear a rectangular sample with a cut in the edge at the center of the shorter side. The two tongues are gripped in a tensile tester and the force required to continue and tear is measured.

Toning: Previously-practiced method of after shading (Shading) on fast dyes, usually vat and sulphur dyes, (due to the lack of suitable products in these groups) with small quantities of brighter dyes from other categories (usually cationic dyes). This has the effect of reducing overall fastness to a greater or

lesser extent. Dyes with 1 : 2-metal complex dyes are used predominantly for toning using acid dyes.

Top: After-dyeing of fibres in mixtures, particularly to light dyed fibres in single-bath or two-bath systems. Used predominantly for reserve and for creating two- or multi-colour effects.

Top, in man-made fibres: A sliver obtained by drafting, along with breaking or cutting a multifilament tow. (a) Worsted process: A sliver in which the fibres have been parallelized and usually combed. (b) Man made fibres or tow to top process: A sliver obtained by drafting, along with breaking or cutting a multifilament tow.

Top, in wool: A continuous untwisted strand of wool fibres from which the shorter fibres or noils have been removed by combing.

Top, in worsted processes: A sliver in which fibres have been parallelised, and usually combed.

Top cloth: Generic term for all materials which determine the external appearance of an item of clothing.

Top colours: Colors used on the ground colour to form a design.

Top dyeing: (1) The process of covering with an additional dye, not necessarily of the same colour or class, to obtain the desired shade. (2) Fibre in top form is placed in cans and dyed in a batch-dye vessel with reverse cycling capability. An expensive process that is used primarily for fancy yarns.

Top fusing: Term used to describe the direct bonding of lining fabrics for collars and sleeves.

Top stop, in Zipper: A part affixed between or immediately above the interlocking elements on either or both stringers, to prevent the slider from leaving the chain.

Topcoat: A light overcoat.

Topper: (1) Automated machine for trouser waist-band steam pressing machine after dry cleaning. It replaces the time-consuming and technically expensive process of manual steaming or pressing of trouser waist-bands. (2) Garment manufacturing term: a) leisure jacket with the face edge and under seam at right angles; (b) short, elegant gentleman's summer coat, fashionably wide and with lightly padded chest.

Topping dyes: Dyes for topping which as far as possible do not dye the foreign fibre or only slightly. They should be simple to apply.

Topstitching: Often used for decorative purposes, but can add durability. A line of stitching that shows on the face side in the finished article,

usually stitched while having the face side of the fabric up, but when sewn close to the seam edge, it is called edge stitching and can be used instead of understitching. See **Understitching**.

Toque: Small flat hat with a narrow brim or brimless.

Torchon lace: A coarse lace made from cotton or linen thread, often with a shell design. It is inexpensive and not hard wearing, due to the fact that the threads are loosely twisted and it is quickly made.

Torque: A moment (of forces) which produces or tends to produce rotation or torsion.

Torque yarn: See **Bulk yarn**.

Torque yarn: Yarns which are fabricated discontinuously by means of high twist, fixation and un-twisting (“conventional” or “classical” process) or continuously (false twist process). Simple yarns with twisting tendency (Up-twisting of suitable high twist yarns with S- and Z-twist gives compensating possibilities).

Torsion, residual: See **Residual torsion**. Revolutions made by a specified length of cord when one end in a flexed position and the other allowed to turn freely.

Tortin: Low grade French wool carpets.

Tossed pattern: An arrangement of motifs where the motifs in a repeat do not occur at regular intervals. It is as if the designs are dropped in a fairly random way onto the fabric.

Total colour difference DE*: The CIE Lab Colour Space total colour difference between two samples is termed DE* and is equal to the square root of the sum of the squares of DL*, Da* and Db*. Where the designation Da* for a difference in red/green value and the designation Db* for a difference in yellow/blue value. CIELAB total colour differences ΔE* can be expressed either as the co-ordinates of colour space or as the correlates of lightness, chroma and hue. Hence

$$\Delta E^* = [(\Delta L^*)^2 + (\Delta a^*)^2 + (\Delta b^*)^2]^{1/2}$$

or

$$\Delta E^* = [(\Delta L^*)^2 + (\Delta C^*)^2 + (\Delta H^*)^2]^{1/2}$$

Total colour management: Special software for recording, monitoring and evaluating dye strength, substrate routine, correlation, transferability from laboratory to production, specification and corrections calculation for continuous and exhaust dyeing, batch production, storage contents and recipe

recording, machine programmes, management programmes, colour kitchen software etc.

Total crotch length, in body measurements: The distance from the right shoulder line midway between the neck base and the shoulder joint, down the back through the crotch and over the projection of the right breast to the starting point.

Total denier (Of Tow): The product of the denier per filament times the number of filaments in a tow.

Total elongation of rope: The entire elongation at any given applied force.

Total hardness: The total of Temporary and Permanent Hardness of a water sample.

Total irradiance: Radiant power integrated over all wavelengths at a point in time expressed in watts per square meter (W/m^2).

Total mass, in pile yarn floor covering: The mass of all matter in the mass per unit area expressed in grams per square metre (Ounces per sq. yd.) or in grams per linear metre. (ounces per linear yard).

Total oxygen demand, TOD: TOD can be measured by the depletion of oxygen in A nitrogen oxygen carrier gas in a platinum catalysed combustion chamber.

Total reflectance: Reflectance of radiant flux reflected at all angles from the surface, thus including both diffuse and specular reflectances.

Total reflectance factor: The total reflectance factor is indicates the relation between the reflected and the incident light. It independent of the illuminant used in the measuring instrument . This statement is valid as long as no fluorescence is present. With fluorescent, e.g. optically brightened samples the total reflectance factor heavily depends on the distribution of energy and the intensity of the illuminant used in the photometer. For this reason with optically brightened samples it is essential to use an illuminant similar to daylight.

Total thickness, in floor covering: The distance between upper and lower surfaces of a material including the pile and backing measured under specified conditions (pressure).

Total vertical trunk length, in body measurements: The distance from the right shoulder line midway between the neck base and the shoulder joint, down the back through the crotch and over the projection of the right breast to the starting point.

Total weight: The mass per unit area expressed in ounces per square yard or grams per square meter.

Toughness: The property of a material by virtue of which it can absorb energy.

Toughness, breaking: The actual work per unit volume (or per unit mass) of material that is required to rupture the material. It is proportional to the area under the load elongation curve from origin to breaking point.

Toughness At Rupture: Toughness of a material to breaking or tearing apart.

Tournay carpet: Named after the Belgian town, a wire insertion pile velour carpet with numerous and varied coloured warp pile giving sharply defined jacquard patterning; also seen as Face-to-face Tournay carpet in a double velvet technique.

Tow: (1) The coarse, entangled and shorter flax fibre, separated from the linen in the hackle; used for tow yarn, upholstery, binder twine, lining refrigerator cars, etc. (2) Combed top. 3. 3. spin, fibre tow: manufactured form of chemical fibres which are combined taken off the spinning jets as a bundle of parallel aligned, single endless fibres; virtually no twist Multifilament with counts of > 3 ktex. Further processing is by means of cutting and breaking (converting) or by stretch-break or texturing. (4) Marine rope.

Tow conversion into staple fibre: This is a process, by which fibre is cut into staple yarn employing mechanical cutting devices called “staple cutters” and generally placed in the final stage of the fibre production lines. With the time, various fibre cutting systems have been developed, but only few are now still operative, at least for the production of standard staple fibre for textile use. E.g. “Lummus” staple cutting machine, “Gru-gru” staple cutting machine.

Tow dyeing process: Dyeing facilities (perforated-drum or perforated conveyor system) for continuous processing for the dyeing of spinning tow.

Tow Linen: These are the shorter, less desirable flax fibres separated from bast line fibres in hackling. Tow linen is usually carded and spun into a woollen-style yarn. A wonderful use for tow linen is to knit bath mitts -- a situation where you want all of the rough, scratch nature of this yarn.

Tow, in manufactured fibres: A twistless multifilament strand suitable for conversion into staple fibres or sliver, or for direct spinning into yarn. A large strand of continuous manufactured fibre filaments without definite twist, collected in loose, rope-like form, usually held together by crimp. Tow is the form that most manufactured fibre reaches before being cut into staple. It is often processed on tow-conversion machinery into tops, sliver, or yarn, or on tow-opening equipment to make webs for various uses.

Tow yarn: Yarn spun from tow.

Towel: An absorbent textile product used for drying or wiping.

Towelling: Towelling is madder from terry cloth which is given elsewhere. The heavier weight terry cloths are used for towels have atypical construction of 60×30 with 2/20s warp and 10s filling. Still heavier construction are used for bath matts. The heavier towels are made in plain weave either from cotton or a mixture of cotton with linen tow. An average construction is about 40×36 with 15s warp and 8s filling. Huck back or huck towels have a pebbled surface caused by the weave. A common huck back texture is 60×40 with 16s warps and 10s filling.

Towels, glass: These are the costliest of the kitchen towels. They are made of linen or of long staple cotton yarns. After being carefully combed to remove all lint the yarns are spun with high twist and are then singed to remove all protruding fibres. Linen or part linen glass towels are made with plain weave with a typical construction of 60×40 with 20s warp and 15s filling and decorated with coloured stripes.

Toxic Unit Acute (TU_a): The TU_a is defined as reciprocal of the waste water concentration that caused the acute effect by the end of the exposure period.

Toxic Unit Chronic (TUC): The TU_c is defined as the reciprocal of the effluent concentration that caused the acute effect by the end of the exposure period, are no different from the control

$$TU_c = 100/\text{NOEC}$$

where NOEC = No-observed-effect concentration.

Tracery: Name for the raised work in Honiton bobbin lace.

Tracing Braid: Narrow military soutache.

Tracing Cloth: Fine, plain woven cotton or linen cloth finished with heavy dressing, but transparent; used by artists and architects for drawing or tracing.

Tracing wheel: Used to make mark perforations on the fabric to indicate seams, darts, and the position of pockets, necklines, pleat widths, etc. By using a carbon paper, these can be used to transfer markings on both sides of the fabric. The tracing wheel should be made of steel and have sharp edges.

Track suit fabric: A synthetic knit with slightly sueded backing made from polyester or polyester/cotton. It is of medium thickness, and in plain bright colours, black and white. Used for track suits, anoraks, trousers, shorts and it is an excellent fabric for children's clothes.

Tracking (in Carpet): A general change in the appearance of a textile floor covering from edge to middle of a narrow band caused by repeated walking over the same area which may result in a localized change in the orientation and may be irreversible. See also Shading in carpet.

Trademark: Legally protected word and/or symbol denoting goods which have been fabricated in the same way by a certain company and can be differentiated from similar goods, such as, for example, the Indathren trademark. Trademark designation by the letter ® represents the so-called “Registered Trade Mark”. (Quality symbols.)

Tragacanth: (gum tragacanth), Vegetable gums produced from the southern *Astragalus* species which has various forms, is up to 20 cm long and yellow-red brown in colour (also bleached white); normally found in powder form. Tragacanth consists of 50–70% Bassorin.

Good quality tragacanth is transparent. The following types are differentiated: Smyrna tragacanth, Morea tragacanth (Greek), Syrian tragacanth.

Tram (Silk): Yarn of two or more greige threads which have been doubled without preliminary twisting and twisted with 150-200 twists per metre. A lofty voluminous yarn, soft and supple when boiled off it has an elegant lustrous effect. Dyed as yarn it is a preferred weft material for colour woven material. More strongly twisted it can also be used for knits.

Tramlines: (1) Localized faults in fabrics, in the warp direction (dent stripes). (2) Missed sections in direct printing due to uneven repeat.

Trame: French for tram and for filling in general.

Trammage, in woven crepes: A puckered area in which a filling yarn has twist running in the same direction for several picks instead of alternating S and Z twist.

Tramped Dornoch: Scotch linen cloth.

Transcendent, in testing: This is the meaning that many people connect with the word quality. It implies that the product has an elusive something that makes the product better than all the competing products. Another view is that the product is superior to all competing products in every way possible. The problem with this approach is that quality cannot be defined in a way that can be used for quality management.

Transesterification: In the production of polyester from dimethyl terephthalate and ethylene glycol, the process of exchanging ethylene glycol for the methyl groups to obtain bis-®-hydroxyethyl terephthalate. The methanol generated in the reaction is removed as it is formed to drive the reaction to completion.

Transfer coating: Process for coating or laminating fabrics in which adhesives and coating compounds are not applied directly to the fabric width but are first applied onto a specially prepared paper (release paper) or endless metal band, onto which they are dried and subsequently combined with the fabric. This circumvents the problem of unwanted push-through of coating compounds.

Transfer printing: Indirect Transfer printing processes. Printing does not take place directly onto the fabric but onto paper. During the transfer printing process a paper printed with special disperse dyes is brought into contact with fabrics, knitted fabrics or nonwovens made of synthetic fibres (particularly polyester, triacetate, possibly polyacrylonitrile and polyamide) at a temperature of 190–215°C for 18–30 s. This causes the greater part of the printed dyes to sublime from the paper and be adsorbed onto the fibre material causing it to take on the pattern.

Transfer paper printing/gravure screen size: For printing paper for Transfer printing with water based printing pastes on a vertical roller printing machine a 60 mesh screen is used. Eight colours can be printed onto the paper using the Portalrouleaux printing machine prior to drying in an overhead drier. Disperse dyes are normally used.

Transfer printing calenders: For standard fabric widths with a roller diameter on the electrically heated cylinder of approx. 800 mm, for production speeds of approx. 10 m/min.

Transfer printing Dyes: Non-sublimation-fast Disperse dyes which (when printed on an intermediate carrier) are transferred to the textile substrate during transfer printing at high temperatures.

Transfer printing papers: Are available in two categories: omnibus and exclusive quality. The former quality is supplied at a reduced price to all interested parties without any type of limitation, usually with a minimum quantity of 500 m. The second quality can be reserved for certain companies for the duration of a year or longer at a corresponding surcharge with no minimum quantity being specified. Manufacture is by means of gravure printing, offset printing, screen printing.

Transfer printing Resist Effects: Printing over or under a board with a print paste in which a blocking agent ensures that the dyes on the board are not transferred. There are two possibilities: a) blocking agent in the form of reactant resins, e.g. hexamethoxy methyl melamine and acid catalysts; b) blocking by means of metal salts with complex-forming capability. All salts of multi-valent ions such as iron, chrome, cadmium, aluminium can adopt this function. Copper is the most suitable in the form of acetate in a copper/amine complex.

Transfer tail: A long end of yarn wound at the base of a package that permits increased warping or transfer efficiency by providing an easily accessible connecting point for the succeeding package.

Transition temperature: A temperature at which some radical change, usually a phase change, in the appearance or structure of a substance occurs.

Examples of transition temperatures are melting point, boiling point, and second-order transition temperature.

Transmittance: The ratio of transmitted light to incident light under specified geometric and spectral conditions. Regular transmittance (of transparent materials) is the ratio of undiffused transmitted light to incident light.

Transmittance factor: The ratio of the light transmitted by a specimen and evaluated by a receiver to the light passing through the same optical system and evaluated by the receiver when the specimen is removed from the system.

Transparency: The measure of light transmitted by a transparent medium. It is a function of the wavelength of light and decreases exponentially as the wavelength of the incident light increases. The transmission ratio is the ratio of the transmitted luminous flux to that incident upon a transparent medium. It is the reciprocal of opacity.

Transparent: Describes a material that transmits light without diffusion or scattering.

Transparent prints: Cotton fabrics can be made transparent (parchmented) by printing with suitable chemicals. See Transparent and opal finishes.

Transparent velvet: Lighter in weight than Chiffon Velvet, soft and silky with good draping qualities. Made with a silk viscose or acetate backing and viscose or nylon pile.

Trapezoid tear tester: See **Elemendorf tear tester**.

Trapezoid tearing load: The force required to propagate a tear in a specimen that has been prepared in the shape of a trapezoid and the which has been clamped for testing on the opposing edges of the nonparallel sides.

Trapped end: An end that is unable to unwrap or unwind from the beam. Trapping of an end may be prolonged or intermittent depending upon the cause of trapping (e.g., rolled ends at the selvage, short ends, or mechanical difficulties).

Trasfer paper printing: See **Transfer printing**.

Trash, in cotton: Undeveloped seeds, motes, small bits of seed coat, or particles of leaf appearing as specks.

Trash removal device, in open end spinning machines: A system for removing impurities from the opened feed stock before the fibres conveyed to the rotor.

Trashmeter: An instrument which optically measures the amount of trash on the surface if raw cotton sample as presented to the viewing window.

Traveller: A C-shaped, metal clip that revolves around the ring on a ring spinning frame. It guides the yarn onto the bobbin as twist is inserted into the yarn.

Travers: French term for various weft striped fabrics.

Traverse length: The lateral distance between the points of reversal of the wind on a yarn package.

Traverse ratio: See **Wind ratio**.

Traverse winding: Winding of threads with slight traverse movement resulting in the individual thread layers not being located exactly above one another. This strengthens the spool edges and a better spool form results.

Treadling: The treadling (treadling order, treadling sequence) is the order in which the treadles are depressed, i.e., the order in which each shed is made.

Treated fabric: A fabric to which a finish has been applied in order to change the original level of a specific property or properties for example: water repellency, crease recovery, soil resistant, soft handle, water absorbency etc.

Tree Bark: A term describing the rippled or wavy effect sometimes seen when a bonded fabric is stretched in the horizontal (widthwise) direction. This defect is caused by bias tensions present when two distorted or skewed fabrics are bonded.

Tree beard: Colloquial term for Tillandsia fibre.

Trellis: Leviathan Stitch In embroidery a large, diagonal cross with upright cross stitches in the center and between the arms of the cross 1, French term for the net ground as distinct from the pattern in hand made laces; 2, coarse, stout French canvas, made of unbleached hemp; used for bags, trousers for farmers, etc. Embroidery made with coloured materials, the background being cut away; the pattern is usually a climbing vine. French for fancy braid

Trellis Work: See **Trellis**.

Trentaine: French dress goods made of natural wool, having 3,000 warp ends.

TREX : English textile machinery association.

TRI: Textile Research Institute.

Triacetate fibre: A manufactured fibre produced from cellulose triacetate in the forms of filament yarn, staple, and tow. Cellulose triacetate fibre differs from acetate fibre in that during its manufacture the cellulose is completely acetylated whereas acetate, which is diacetate, is only partially acetylated. The FTC notes that a fibre may be called \ triacetate when not less than 92%

of the hydroxyl groups are acetylated. Fabrics of triacetate have higher heat resistance than acetate fabrics and can be safely ironed at higher temperatures. Triacetate fabrics that have been properly heat-set (usually after dyeing) have improved ease-of-care characteristics because of a change in the crystalline structure of the fibre. (Also see **Acetate fibre**.)

Triacetin: Glycerol triacetate. A type of plasticizer for acetate fibres. It is widely used to add firmness to cigarette filter rods.

Triaxial fabrics: Completely isotropic fabrics made in a weaving process employing three yarns at 60° angles to each other. These fabrics have no stretch or distortion in any direction. With equal sizes and number of yarns in all three directions, the fabric approaches equal strength and stiffness in all directions.

Tricel: A branded acetate fibre.

Tricel suede: Soft, supple knit fabric with pile surface and also may be punched. Used for a variety of fabrics for sports and leisure clothes.

Tricel velour: Acetate yarn (Branded) knitted in combination with nylon or polyester results in a rich pile fabric that is soft and comfortable to wear. Fabrics dye well and therefore carry rich strong colours well and also black. Pale colours tend to look patchy but are very attractive. Used for jumpsuits, skirts, casual clothes, leisure wear, and in heavier weight for drapes and furnishings.

Tricelon: A branded name for a blended yarn of acetate and nylon.

Trichloethane: (1,1,1-trichloroethane, methyl chloroform), $\text{CH}_3\text{-CCl}_3$; molecular weight 133.42; density 1.31-1.35; boiling point 74°C (azeotropic mixture with water at boiling point 65°C with 95.7 wt.% trichloroethane). Colourless liquid; volatile; evaporation index 2.6. Not easily flammable. Good solvent for lubricating greases, mineral oils, resins, waxes, tar, vinylidene chloride.

Trichloroethylene: (tri, ethylene trichloride), HC1C=CC1_2 . Colourless liquid, clear as water, nonflammable, evaporates easily, smell similar to chloroform, strong anaesthetizing effect, prolonged presence on the skin causes "burn blisters". Does not corrode standard construction metals (except light metals) at temperatures under boiling point. Not easily soluble in water; hygroscopic; miscible with almost all organic solvents. Dissolves light and heavy greases, oils, resins, rubber, waxes, tar, oil-based dyes (if not too resinated, otherwise + alcohol + benzene soap), bitumens. Dissolving tendency for certain acetate, naphthol and vat dyes; also for polyvinyl chloride fibres (becoming hard and brittle), certain plastic parts (buttons, zips, buckles and the like) as well as plasticised finishes.

Trichloropyrimidine: The basis of certain commercially available reactive dyes.

Trichlorotrifluoroethane: (R113), $\text{CF}_2\text{Cl}-\text{CFC12}$, boiling point 47.6°C ; density 1.58. Refrigerant used in chemical cleaning for cleaning leather, furs and delicate items of clothing in special cleaning machinery.

Trichromat: Perception of colour by the normal sighted.

Trichromatic: Three-coloured (Chromatic), the normal perception of colour (Trichromat).

Trichromatic colour coordinates: Colorimetric measures. In this context the following concepts are identical: trichromatic system X,Y,Z = trichromatic components = norm colour values X, Y, Z. Trichromatic coordinates or coefficients = norm colour value proportions x, y, z.

Trichromatic colour values Identical with the so-called trichromatic Colorimetric measures, also known as tristimulus values or tristimuli.

Trichromatic dyeing: Dyeing with triple combination of yellow (or orange), red and blue (basic colours). Widely used in the dyeing of wool and synthetic fibres, not generally used for dyeing cellulose fibre. Colour triangle.

Trichromatic printing: (three colour printing). Use of printing rollers with appropriately graded engraving depth or templates with corresponding grid with which multi-colour pattern is achieved by means of multiple fall-ons. A 4th roller or template is often used for black or grey.

Tricks: In knitting, the slots which space the needles.

Tricomponent fibre: A fibre consisting of three polymers which are chemically different, physically different, or any combination of such differences.

Tricot: Tricot is one of the most popular fabric structures; It is used for lingerie because it is comfortable, long wearing, and resists runs and fraying. It is a light weight, warp knit fabric characterized by vertical ribs or wales on the right side and slight crosswise ribs on the wrong side. Has a thin texture, made from very fine or single yarns. Glove silk is a double bar tricot (very run-resistant). Tricot machines use bearded needles and they can operate extremely high speeds. Almost any fibre can be made into tricot, including silk, viscose, polyester and nylon. Also used for sportswear, bathing suits, gloves.

Tricot Beam: A metal flanged beam, commonly 42 inches in width, on which yarn is wound for use as a supply for the tricot machine.

Tricot de Laine Woollen suiting used for sailors, etc., in France.

Tricot Ecossais: Variety of crochet work, made with stitches taking in five loops at a time.

Tricot Flannel A heavy and thick flannel, which is quite elastic.

Tricot fabric, warp knitted: It is produced by two fully threaded guide bars which have 1 ∞ 1 lapping movement. The fabric has a light weight and it can be split very easily due to short underlaying movement. The loop will not incline towards one direction, the wale therefore will remain vertical. The appearance of tricot fabrics may generally be improved by using a coloured yarn which gives vertical stripes in the fabric.

Tricot Fabric Yield: The number of square yards per pound of greige or finished tricot fabric.

Tricot Knitting: See **Knitting**. A warp knit fabric in which the fabric is formed by interlooping adjacent parallel yarns. The warp beam holds thousands of yards of yarns in a parallel arrangement, and these yarns are fed into the knitting area simultaneously. Sufficient yarns to produce the final fabric width and length are on the beam. Tricot knits are frequently used in women's lingerie items such as slips, bras, panties, and nightgowns.

Tricot Section: See **Tricot beam**.

Tricot weave: (1) Created in fabrics by tying reverse warp threads (warp rib tricot) or reverse weft threads (transverse tricot) as well a special weave (diagonal tricot). (2) A form of ground structure used in warp knitting in which the threads are transferred from one needle to its neighbour and returned.

Tricotine: The name implies a knit fabric, but it is in fact a firm, durable, clean-finished, warp faced twill-weave with a fine steep twill line. Also known as Cavalry Twill. Dress fabric woven as as double twill, giving a pair of diagonal lines on the right side. It may be made from any fibre, including worsted, polyester, acrylic viscose. Used for trousers, uniforms and coats. See **Cavalry Twill**.

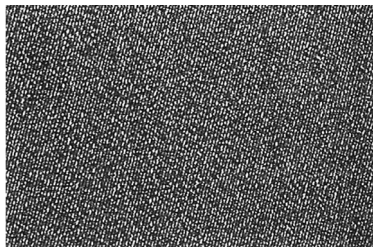

Triethanolamine: $N(CH_2-CH_2-OH)_3$; density 1.119–1.124; boiling point 270–279°C. Reaction product of ethane oxide on ammonia. Thick oil similar in consistency to glycerine, slightly fishy odour, sticky, hygroscopic, absorbs carbonic acid from the air, very alkaline.

Used as emulsifiers, pasting agents for vat dyes, solvents for acid dyes. Also used as additives in lubricating oils. Component part of wetting, cleaning, softening, sizing and finishing products.

Triethylsulphateamine, disodium salt: Used as a resin finishing agent for alkaline wet crosslinking and for two-step processes.

Trimellitic anhydride: (TMA). $C_9H_4O_5$, a hemimellitic acid. Colourless crystals. Use: for synthetic resins, adhesives, textile auxiliaries, surfactants, polyvinylchloride softeners.

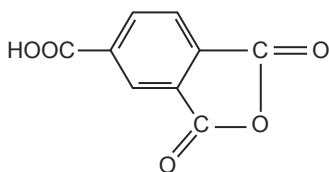

Trim, in textiles: To cut off a portion of a material.

Trimer: A polymer consisting of three monomer units. (Also see Cyclic trimer).

Trimmings: Pieces used to decorate or complete products.

Triphenylmethane dyes: See **Diphenylmethane dyes**.

Triple-beam balance: A weighing device. This term refers to a laboratory-type balance scale. "Triple-beam" simply refers to the fact that there are three bars on which weights slide to counterbalance the item on the pan. Typically, one bar has a weight for tenths or hundredths of a gram, one has a weight for grams, and one has a weight for tens of grams. Often additional weights can be hung from pins to increase the total capacity. Triple-beam balances are moderately priced and quite useful in dyeing. A type with a single pan where the mechanism is below the pan (as opposed to a hanging pan type) with a resolution of a tenth of a gram is a good choice for general dyeing use. There are now many electronic scales available that are very easy to use, but typically a good deal more expensive for comparable capacity and resolution.

Triple Cloth: Made with three sets of warps and three sets of fillings, forming three different layers of cloth, tacked together during the course of weaving.

Triskelion cross section: A trilobal cross section in which the radiating arms are curved or bent. (Also see Cross section.)

Tristimulus: Of, or consisting of, three stimuli; generally used to describe components of additive mixture required to evoke a particular colour sensation.

Tristimulus colourimeter: An instrument that measures tristimulus values and converts them to chromaticity components of colour.

Tristimulus Data: The three tristimulus values that combine to define or generate a specific colour, such as R 255/G 255/B 0. Tristimulus data does not completely describe a colour—the illuminant must also be defined. Also, in device-dependent colour models such as RGB, the capabilities of the viewer or colour-rendering device must also be defined.

Tristimulus filters: Optical filters used in conjunction with specific colour lamps to obtain a response function approximating the tristimulus functions of the CIE Standard observer for source C.

Tristimulus Values (CIE): Percentages of the components in a three-colour additive mixture necessary to match a colour; in the CIE system, they are designated as X, Y and Z. The illuminant and standard observer colour-matching functions used must be designated; if they are not, the assumption is made that the values are for the 1931 observer (2° field) and illuminant C. The values obtained depend on the method of integration used, the relationship of the nature of the sample and the instrument design used to measure the reflectance or transmittance. Tristimulus values are not, therefore, absolute values characteristic of a sample, but relative values dependent on the method used to obtain them. Approximations of CIE tristimulus values may be obtained from measurements made on a tristimulus colorimeter that gives measurements generally normalized to 100. These must then be normalized to equivalent CIE values. The filter measurements should be properly designated as R, G and B instead of X, Y and Z.

Tristimulus values X,Y,Z: See **Tristimulus values**.

Tritinum: Medieval silk fabric, made with three-ply warp.

Tritik: (Plangi-Tritik, crimped batik). Plangi technique, in which yarn, threads or bast is drawn into the fabric in ruffles corresponding to the pattern and then gathered before dyeing, in order to produce resists during the dyeing process.

Trolly Lace: Term for bobbin laces having the patterns outlined with a heavy cord.

Tromp: “Tromp” is an old way of saying “step” on a treadle. Tromp as writ means to step on the treadles in the same order as the shafts are threaded (also called “treadle as drawn in). If the shafts are threaded 1-2-3-4; to tromp as writ or treadle as drawn in, you step on the treadles in that same order, 1-2-3-4.

Tropical: Light worsted yarn goods in linen or Panama weave, plain or patterned (yarn or colour-effect patterns); up to 300 g/running m; with napless finish. Used for men and boys’ outerwear and women’s outerwear summer

clothing. Fine hard-twisted worsted fabric in plain weave is wrinkle resistant and breathable and have been termed ‘coo-wool’.

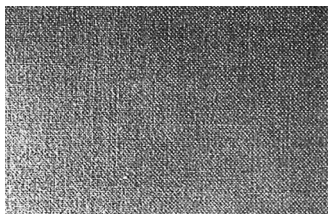

Tropical Cloth: Very light men’s wear fabric, used for summer clothes, made usually with cotton warp and mohair filling, showing various colours and designs.

Tropical Weight: Suitings weighing from 9 to 11 oz. per yard.

Tropical worsted: A plain or fancy weave worsted cloth, very light in weight and mainly in light colours, beige and white. An excellent cloth for hot weather as the high twist worsted yarn makes it cool. It pleats and creases well. Used for men’s suits, women’s suits, etc.

Trousering: A large variety of woollen and worsted fabrics, also cotton worsteds, used for trousers.

Trousers: Garments for the lower limbs; widely, but erroneously, known as “pants.”

Trubenizing: (Trubenizing process), for the purpose of chemical stiffening of men’s laundry (without using finishing products). Method for stiff collars: a lining which has been soaked with cellulose acetate and swollen with solvent (acetone) is inserted between the outer fabrics beforehand and then bonded to them using a hot iron. This type of collar is soft when wet, washes well and always achieves its original stiffness again (without the use of a finish) after ironing.

True: Fibres are called true which have a uniform diameter.

True designs: In weaving, those parts of a section blanket where a weft section is woven on the warp section for which it was intended.

True guage length: A precise length between wee-defined bench marks located on the specimen while under known tension in the unsupported portion between the holding clamps and free from contact with any snubbing surfaces or other surfaces which could result in non-uniform strain.

True rise, in body measurements: The vertical distance (Plumb line) from the waist level at the side to the crotch.

True tensile strength: The maximum tensile stress expressed in force per unit area of the specimen at the time of rupture. (Also see **Tensile strength**.)

Truffette: Fine, narrow, bleached French linen; used for handkerchiefs, shirts, etc.

Trunk: Length Medium long women's hosiery, reaching above the knees, but shorter than opera hose.

Trunk: Double the length of a coverall, from the center of the neck hole at the back to the point of the leg separation on the seat seam.

Trunk hose: Short, heavily padded breeches tied at thigh, often with differently coloured slashes.

Trunnions, In Zipper: The two pivots at the ends of the pull that fit into the bail.

True guage length: A precise length between well-defined bench marks located on the specimen while under known tension in the unsupported portion between the holding clamps and free from contact with any snubbing surfaces or other sources which could result in non-uniform strain.

Truxillo: Inferior Spanish wool.

Tsatlee: Raw silk reeled in northern China, according to the primitive, native methods, producing uneven and irregular yarn.

Tsudzure-no-nishiki: Japanese brocade made of strong silk warp and twisted gold paper filling, made like gobelins.

Tsumugi: A narrow and very expensive Japanese silk fabric made as follows: the silk is spun into a heavy yarn and woven into a coarse cloth with cotton warp. This cloth is run several times through the vat and then buried in the ground. After the cotton warp had rotted, the silk is rewoven into a fabric, the spots which were left unaffected in the dye, forming a mottled design; used for kimonos.

Tuanse: A Chinese satin.

Tuareg: Wool rugs made in Morocco.

TS: Turk. Standardlari = Turk. Standard.

T-Shirt Formerly a short-sleeved vest; today, this is a term used for a multitude of different fashionable casual shirts, with or without sleeves (short or long sleeved), coloured, printed, and decorated with motifs, etc.; made from knitwear.

T.S.P: (or TSP) – Na_3PO_4 , trisodium phosphate; also called “sodium phosphate, tribasic” TSP is sometimes used to produce pH in the range of

about 12 for dyeing processes. It may be used in scouring. Strong solutions can be very irritating to skin, so handle it with care.

Tsatlee silk: Chinese Grège yarn from live cocoons, products from the cottage industry, non-uniform.

T screens: Rotary screens for printing transfer printing papers. They have a particularly smooth surface and 80 mesh size to compensate for the sensitivity of transfer printing to any unevenness in the screen due to low absorption capacity of paper.

TSE: Turkish Standards Association.

TT process: Thermofixation and thermosol process.

TTZ: Cloud point index.

Tub: See **Beck, Jet dyeing machine.**

Tub dyeing machine: To shorten the liquor ratio in yarn dyeing, the dyeing volume (otherwise a dyeing boiler) is sectionalised into a number of tubes. A dye column is dyed separately in each tube.

Tube: (1) A cylindrical holder or bobbin used as a core for a cylindrical yarn package. (2) A cylindrical yarn package.

Tubeless cross-wound yarn package: Wound packages without a batch centre (dyeing tubes). Promotes better penetration of dye.

Tubing: Braided, knitted, or woven fabric of cylindrical form having a width of 100mm. (4 in.) or more (Circumference of 200 mm. (8 in.) or more.)

Tubular fabric: A fabric woven or knit in a tube form with no seams, such as seamless pillowcases, some knit underwear fabrics, and seamless hosiery. (Also see Circular knit fabric).

Tubular fabric dye padder: Padder for the continuous dyeing of tubular cotton wear with reactive dyes according to the CPB method. After impregnation of the tube which is width guided through, it is blown up like a balloon by air-injection nozzles and then squeezed out.

A warping device is used to lay the edges of the tube marked by the squeezing process.

Tubular fabric dyeing: (1) Term from piece dyeing which is used for fabric or knitwear with the edges sewn together to form a tube and dyed on the winch as an effective way of countering selvedge curling. (2) Dyeing of tubular knitwear

Tubular fabric mecerising machine: Tubular knitwear which has not been cut open should be mercerized without fixing the fold creases. For this reason,

the impregnated hose is blown during stabilisation in the following steps A = roller-vat type impregnation zone using the squeezing unit; B = mercerization cartridge with controllable lateral and longitudinal tension and end squeezing unit; and C = wash, neutralizing and rinsing step.

Tubular fabric slitting machine: (tube openers). They are used to slit open tubular knitted goods to expose the surface of the fabric to the finishing process. The slitting process can be achieved using burners (welding) or cutters. A cut thread or Separating course is provided for this purpose and is picked up by electronically controlled units. The tube slitting machine detects the separating course using a photo electronic device and opens the tubular wear automatically.

Tubular fabric turning machine: Device for turning tubular knitwear using aerodynamics. The tubular wear is pushed on to the turning tube (length 3 000 mm, Ø 180 mm). The end of the piece is drawn into the tube opening aerodynamically and this turns it at the same time. Fabric speed is 600 m/min (loading) and 300 m/min. (unloading).

Tubular felt: (felt sleeves). Industrial wool felt in the form of continuous woven or nonwoven pressed felt for covering rollers (lapping), for sizing and finishing machines, calendars, for transferring printing in roller printing, etc. also used as an underlay for machine foundations and seals, etc.

Tubular gauze: Tubular fabric made from screen gauze used on nickel screens in rotary-screen printing.

Tubular knit goods: See **Tubular fabric**.

Tuck: (1) Lightweight cotton or silk fabric, made with pleats running from selvage to selvage and formed with a separate warp and a filling usually heavier than that used for the ground weave; used for shirts, waists, etc.

(2) A flat fold in a fabric; there is difference between a tuck and a plait.

Tuck, in rope: A free strand of rope placed between rope strands during rope splicing.

Tuck Knitting: Framework knitting, in which a number of loops are accumulated on a needle, thus forming the design.

Tuck stitch: A knitting stitch made when a needle receives a new yarn without losing its old loop. This is the stitch which has the reverse V shape. The loop head of a tuck stitch together with the previous loop head are held by the feet of the following stitch. Normally, a tuck stitch with more than four successive tucks on the same needle should not be used due to high yarn tension and needle damage (not more than six adjacent tucks due to freely floating and

snagging). The tuck stitch reduces the lengthwise elasticity of the fabric and the fabric length, while it increases the widthwise elasticity and width of the fabric. It also increases the fabric thickness and needs theoretically less yarn.

Tucked seam: A complex seam formed on the inside of the object with neither raw edge.

Tucking position, in knitting: The needle butt follows the cam track and is pushed upwards by the cam. The old loop moves downwards and opens the latch of the needle. Sinker still moves towards machine centre, thus fabric is held down in the sinker throat. However, the old loop is still on the latch. This position is also used to produce tuck stitch.

Tucks: This is the stitch which has the reverse V shape. The loop head of a tuck stitch together with the previous loop head are held by the feet of the following stitch. Normally, a tuck stitch with more than four successive tucks on the same needle should not be used due to high yarn tension and needle damage (not more than six adjacent tucks due to freely floating and snagging). The tuck stitch reduces the lengthwise elasticity of the fabric and the fabric length, while it increases the widthwise elasticity and width of the fabric. It also increases the fabric thickness and needs theoretically less yarn.

Tucks, in garments: Tucks are folds of fabric stitched down either all or part of the way, such as released tucks. Their purpose is mainly decorative although they may also be used as a shaping device. They are usually folded on the straight and each tuck is formed from two stitching lines that are matched and stitched. The distance from the fold to the matching line determines the tuck's width. Tucks that meet or overlap slightly are called blind tucks; those with predetermined space between them are spaced tucks; and a pin tuck is a very narrow tuck, usually about 3 mm (1/8 in) wide. Light to medium weight fabrics are suitable for tucking, but design and print should be considered before purchasing the fabric. Tucks can be added to plain garments by pre-tucking the fabric before it is cut.

Tucks, corded: Fold the tuck, positioning the cord inside the tuck along the fold. Pin in position and, using a zip foot, stitch close to the cord.

Tucks, cross: First stitch the lengthwise tucks and presses in one direction, then form the cross tucks at right angles to the first set and stitch. Be sure to keep the first set of tucks facing downwards.

Tucks, Released: These dart tucks are usually used to control fullness at the bust or hip. They are mainly formed inside and can be released at one or both ends. Be sure to reinforce the ends. Press carefully to avoid creasing the folds.

Tucks, shell: First stitch the tuck, then hand stitch a few overhand stitches every 1 cm (1/2 in) to form a scallop. Alternatively, blind stitch by machine,

with the tuck under the foot and the fold to the left of the needle, allowing the zigzag stitch to scallop the tuck.

Tucking defect, in knitted fabrics: One or more unwanted tuck loops.

TUDO: Thiourea dioxide.

Tuft: (1) A cluster of soft yarns drawn through a fabric and projecting from the surface in the form of cut yarns or loops. (2) The portion of pile-like material that comprises a tufted fabric or carpet. (Also see **Tufted fabric** and **Tufted carpet**.)

Tuft, in pile yarn floor coverings: Those cut or uncut loops which are attached to the backing fabric at one binding site and which form a part of the fabric face.

Tuft bind, in pile fabrics: The force required to pull a tuft from a cut pile floor covering or to pull free one leg of a loop from a looped pile floor covering.

Tuft element, in pile yarn floor covering: A segment of yarn bound to a backing fabric at a binding site so that two portions (legs) of the yarn project above the backing fabric, one portion on each side of the binding site.

Tuft height, for pile yarn floor covering: The length of the tuft leg.

Tuft Leg, for pile yarn floor covering: One of the two portions of a tuft element that project above the backing fabric on the pile side of the floor covering.

Tuft length for pile yarn floor covering: The length of the tuft element measured while extended in a straight line under zero tension.

Tuft bind: Force required to pull a tuft from carpet.

Tufted Carpet: Carpet produced by a tufting machine instead of a loom. It is an outgrowth of hand-tufted bedspreads. Today, broadloom tufting machines produce over 90% of all domestic carpeting. Tufting machines are essentially multi needle sewing machines that push the pile yarns through a primary backing fabric and hold them in place to form loops as the needles are withdrawn. The loops are then either released for loop-pile carpets or cut for cut-pile carpets. The pile yarns may be either pre-dyed or uncolored, in which case, the greige carpet is then piece-dyed or printed. In either case, a latex or other binding agent is applied to the backstitch to lock the tufts in place and to secure the secondary backing fabric. Formerly, all carpets were woven, either by hand or machine. The significantly greater productivity of tufting has revolutionized the carpet industry and made soft floor coverings available to the mass market.

Tufted embroidery: Lace fabric, usually composed mainly of cotton and possibly nylon to create a firm base, with gold, silver or coloured tufts inserted into the right side of the fabric in pattern.

Tufted fabric: A fabric with a pile consisting of tufts or loops formed by inserting yarn into a previously prepared backing fabric. Cotton sheeting, lightweight duck, or other fabric decorated with fluffy tufts of multiple, soft-twist cotton yarns or manufactured fibre yarns closely arranged in continuous lines or spaced at intervals to produce the type of fabric called

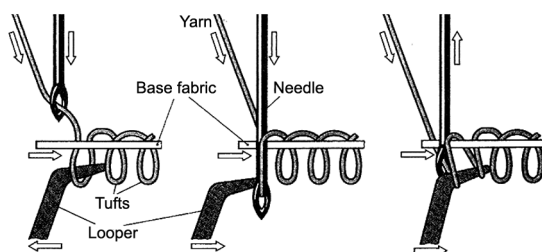

Tufted fabric production schematic

candlewick. The tufts are inserted and cut by machine in previously woven fabric or are woven in by the loom and afterwards cut to form the tufts. They have a chenille-like softness and bulk and are erroneously called chenille. Patterns vary from simple straight lines and elaborate designs to completely covered materials resembling long pile fabrics. They may be white, solid coloured, or multicoloured. Tufted fabrics are used for bedspreads, bath mats, and robes, etc.

Tufted fabric: Any fabric made from any yarn or mixture of yarns in which a pile is created by inserting an extra yarn, often thicker than the backing. Some tufts are locked in position and are easily removed (e.g. Candlewick).

Tufted textiles: These are fabrics which are made by inserting yarns, into a usually textile backing, using one or more needles, forming loops (pile loops). The loops may be cut and/or fixed to the backing using an adhesive or by heat sealing.

Tufting: The manufacture of Tufted textiles, in particular Tufted carpets, using the tufting technique.

Tufting, in upholstered furniture: Localised indentation of upholstered furniture surfaces and cushions, by the use of or appearance of buttons, providing an aesthetic treatment.

Tufting machine: A machine for producing tufted carpets.

Tufting needle: An instrument for inserting tufts into a premade substrate. As in a sewing machine needle the eye and the point are at the same end. The needle is grooved on one side, to take the yarn and chamfered on the other side to lead the looper on to the needle.

Tufts to a carpet backing: Bonding a secondary backing to a primary backing, or increasing fabric body or stiffness.

Tugop: Bast fibre, yielded by a species of the Artocarpus tree in the Philippines; used for twine and cordage.

Tulle: Made in silk, nylon, cotton. Weave is normally Guaze, knotted, leno, made on a lace machine. Name is derived from Tulle, France. First made by Machine in 1768. Has a hexagonal mesh and is stiff. It is difficult to launder. Comes in white and colours, and is very cool, dressy, and delicate. Uses: It is a stately type of fabric when used for formal wear, and weddings. It is also used for ballet costumes and wedding veils.

Tulle Crinoline: Same as pleated tulle, made with gradually increasing meshes, which force the tulle into pleats.

Tulle Grec: French tulle made with meshes larger than in ordinary tulle.

Tulle, warp knitted: Plain net fabrics made on a bobbinet machine or simulated by warp knitting. The honeycomb-type structure may be used as such or as a base for embroidery, for sophisticated blouses and dresses, trimmings, layering or veils.

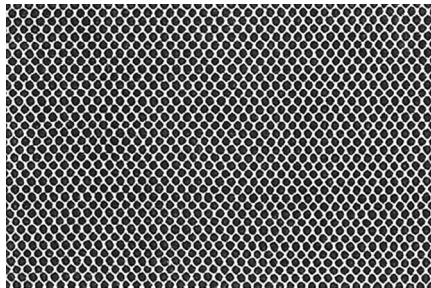

Tumble drier: A drying machine with a rotating, perforated drum, in which the material is spun loosely, without tension, and discontinuously or continuously.

Tumble dry: Drying with hot air in a tumbler, the usual term for the drying method used when testing the fabric smoothness of resin-finished textiles after household washing (Wash-and-Wear Standards).

Tumbler finishes: After treatment agents for washable textiles, for the application of active substances (finishing, anti-static, fragrance) during the

drying process in the tumble drier or drum drier. Form of application: as foam spray (carrier: cloth/item being washed), spray (carrier: drum walls), pad impregnated with active substance (fixed by adhesive to tumble drier paddles) and Sheets.

Tumbler shrinkage: Unwanted shrinkage, which can arise when items of clothing made from heavy cotton fabrics are dried excessively in a tumble drier after washing.

Tunic: Women's or men's shift style robe sewn from two pieces of fabric.

Tunis Crochet: A very easily executed crochet, made only in straight work with single ribs.

Tunnel test: See Flammability tests.

Turbelik: Turkish name for Oriental rugs, intended to be hung over graves; the designs are always tree and flower patterns.

Turbidity: The decrease in optical transparency of a solution because of the presence of particulate matter.

Turbidity, in waste water: Turbidity, a measure of the light transmitting properties of water, is another test used to indicate the quality of waste discharges and natural waters with respect colloidal and residual suspended matter.

Turbidity unit, TU: Various units are used to measure turbidity in water. One method is to use a suspension of silica. Another method is to compare the water to a standard formazin solution as measured in a *nephelometer*. This gives the *nephelometric turbidity unit* (NTU) or *formazin turbidity unit* (FTU). The 1998 EU Drinking Water Directive states that the turbidity must be acceptable to the consumer. A value of 1 NTU ex water treatment works is the desirable maximum. The WHO guideline maximum value is an average of 1 NTU for drinking water.

Turbostapler yarns: High-bulk yarns (strongly textured yarns). Manufactured on a turbostapler. A tow made up of high-shrinkage fibres of varying lengths is passed through electrically heated plates then stretched, thus gaining high residual shrinkage.

Turka fibre: Brown or white coloured soft fibre yielded by the bark of the apocym venetum, grown in Asia and southern Europe; used for twine, baggings, etc.

Turkey red oil: TRO is sulfated castor oil. Ricinoleic acid, the major acid in castor oil has both a hydroxyl group at the C₁₂ position and a C=C at the C₉ position. Both of these groups are converted to sulphate ester linkages so castor oil can have a degree of substitution up to 6.

Turkey Red: (1) A fast and bright scarlet dye, yielded by the madder and formerly extensively used on wool and cotton preceded by various elaborate processes of mordanting. The modern Turkey red, a fast and brilliant scarlet, is a synthetic dye; (2) plain woven or twilled cotton fabric of various grade, dyed with Turkey red; used for dresses, trimmings, etc.

Turkey red oil: (red oils, T' red oils). Consist of Sulphonated surfactants and similar products. Used as wetting, dye penetration and levelling agents.

Turkish Knot: Used in russ; it is formed by the yarn being twisted about the warp threads, two ends of the pile alternating with every two threads of the warp. See **Ghiordes knot**.

Turkish carpets: Oriental carpets from Anatolia and Asia Minor. Original with traditional patterns of flowers stylised to a greater or lesser extent (tulips, daffodils, hyacinths). Introduced to Europe from 15th century and used in particular as wall hangings and table covers.

Turkish towel: Cotton or linen fabric having loop piles formed by a separate set of warps. Is bleached. Used for towels, bath robes, etc. See under terry cloth.

Turkman Rugs: See **Genghis rugs**.

Turkoman: Made with silk or cotton warp and thick chenille filling; used for drapery.

Turmeric: A fugitive direct yellow dye yielded by the roots of the curcuma tinctoria in India and China.

Turn: The distance parallel to the axis of a yarn or rope in which a strand makes one complete spiral. (Also see TWIST.)

Turned and stitched seam-finish: see **Clean-finished seam-finish**. Fold under a 6 mm. (1/4 in.) edge on the seam allowance and press a crisp edge. Edge stitch next to the folded edge. Use thread matching to the fabric. It is a gooway to finish an unlined Jacket for casual wear. Used on light and medium weight fabrics as it does make the seam allowance bit bulkier close to the seam.

Turn-over: The turned in extremity of trouser legs and sleeves.

Turned-over edge: See **Curled selvedge**.

Turn-up: The bottom of trousers.

Turning: The reversing of two or more pieces of material that are seamed together for pressing or topstitching.

Tuskin: A woollen fabric made in England under Edward VI, believed to have been of blue or gray colour.

Tussah: Made in silk, usually plain but also in twill. Made from wild or uncultivated silkworms. It is coarse, strong, and uneven. Dull lustre and rather stiff. Has a rough texture with many slubs, knots, and bumps. It is ecru or tan in colour and it is difficult to bleach. It usually doesn't take an even dye colour. Wears well and becomes more rough looking with wear. It wrinkles a little, but not as much as some. Various weights. Appears in filament and staple form. Uses: In lighter weights, dresses. In heavier weights, coats and suits and ensembles.

Tussah silk: A coarse silk produced by a wild silkworm. There are three main types (a) *Antheraea mytila* (largely indian); (b) *Antheraea pernyi* (largely Chinese); (c) *Antheraea yama-mai* (largely japanese). It is brown in colour and usually spun, since most cocoons cannot be reeled. The yarn has an uneven slub which gives a rough texture to the cloth. Used for suits, dresses, skirts, shirts etc.

Tutorette process: A mechanical shrinking process for cotton/polyester blend fabrics, licensed by Bancroft Far East Inc. in Japan and using the Everest Shrinking Machine (Manuf.: Hunt & Moscrop). Tutorette textured seersucker is a finished crêpe. The regular pattern of the textured surface is achieved by a flatbed embossing calendar. An artificial resin finish is used to fix the embossing.

Tuxedo: See **Dinner Jacket**.

Twanse: Stout Chinese silk satin, finished with little gloss. Comes in solid colours or patterns.

Tweed: Much like homespun in appearance, both being either twilled or plain. They are made from rough worsted yarn spun at home. In tweed the yarn is harder twisted, giving a more distinct twill. Tweeds are commonly woven in a 3/2 twill weave other weaves usually used are plain, broken twill and herringbone weaves. Typical plain woven tweed will have a construction 84 × 20 with two run woollen yarn in warp and filling. It is generally more compact, less rough, and better finished than homespun. Commonly used for sportswear, suits, coats, overcoats, and ensembles.

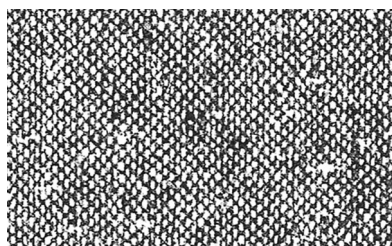

Tweed, Donegal: Plain and herringbone woven similar to Irish tweeds, white nubs are often observed in the warp while filling has nubs of various colours, usually red, blue or green.

Tweed, Harris: Woollen fabric hand woven on Harris and other islands of the outer herbides off western coast of Scotland. The woollen yarn in in this tweeds are made of long, strong wools and the cloth wears exceptionally well.

Tweed, Irish: Usually made with a white warp and a filling of dark shade of blue, brown, black or grey. It is made of 2/2 twill weave often with nub yarns. Irish tweed is normally a little softer and lighter than Harris tweed.

Tweed, Linton: Soft tweed made with Australian Merino wool along with some other animal fibres to make it softer. The fabrics is made only in Carlisle, England.

Tweed, scotch: Similar to Harris tweed in construction white warp and stock dyed fillings are often vivid and highly contrasting.

Tweed Jersey: The old traditional term tweed, which implies hairy, has been applied to a modern fabric. This is a thick knit fabric with fancy knobbls and a hairy surface. It is extremely stretchy and would be suitable for patterns labeled 'knitted fabrics'. The fibre is likely to be acrylic with some wool and nylon. Used for sift suits and dresses.

Twelve-harness satin: A weave similar to eight-harness satin except in warp-faced fabrics warp yarns show on the face of the fabric eleven out of twelve adjacent yarns and in filling-faced fabrics filling yarns show on the face eleven out of twelve adjacent yarns.

Twill: A very rugged fabric woven in 2/2 twill weave with textures ranging from 70 × 40 to 160 × 80 and the width vary from 35 in. to 45 in. The greatest use of twill is in linings and even for infants wear. Usually 150 denier right yarn is used in warp and weft. Sometimes rayon warp and acetate filling or vice versa, is also used. All acetate twill is also uncommon. 110 × 70 may be a typical construction. Cloths in twill weave: Cotton- Jeans, ticking, drill, Canton flannel, denim, gabardine covert cloth, khaki, serge; Linens: Ticking and table and towel twills; Silk: Twill foulard, serge; Wools: serge, worsted cheviot, gabardine, covert, flannel, tweed, unfinished worsted, sharkskin, broadcloth; Rayons, acetate and blends: Gaberdine, foulard, flannel; Polyester: Suitings such as serge and gabardine.

Twill angle: See **Twill Ridge**.

Twill braid, in rope: A braided construction in which one strand of one direction of rotation about the axis passes over two strands of the opposite direction and it in turn passes under the next two strands of opposite direction.

Twill carpet: Flat carpet, woven from coarse yarns in twill weave (Dutch carpets, Parisian, Sayette runners).

Twill damask: See **Damask, twill; False damask.**

Twill ridge: The diagonal ridge in twill weave fabrics.

Twill weave: A weave characterised by diagonal lines produced by a series of floats staggered in the warp direction. Floats are normally formed by the filling (a weft –faced twill) Examples of twill weave fabrics are cotton denim, gabardine, khaki, ticking, whipcord, wool broadcloth, cashmere, flannel, gabsardine, melton, serge, tweeds, whipcord, silk syrah etc.

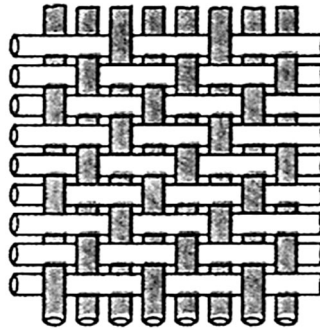

Twill, block: Twills may be woven blocks of warp-faced and weft-faced areas side by side in both in warp and weft directions. Such a twill is called a block twill.

Twill, broken: Broken twills are formed by reversing the pattern part way through the repeat. Usually the break will be at the centre of the repeat, with only one reversal, but more complicated breaks can be made. (Fig) or in the weft direction, and no twill line will be generated.

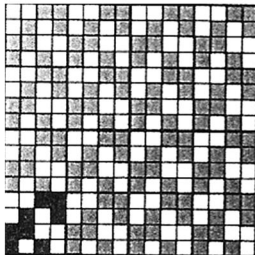

Developed from
20 – 02 02 – 01 – 01

Pattern Draft

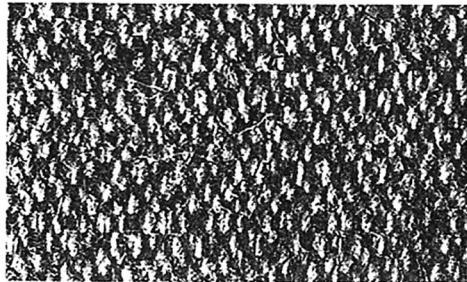

Flattened twill

Twill, even: When the number (or sum of numbers) above the line and the number (or the sum of numbers) below the line are equal the twill is said to be an even twill. In an even twill neither the warp nor the weft predominates.

Twill, Flattened: Flattened twills are usually weft faced, which means that the twill line is formed by the weft yarn and the warp is mainly on the back of the fabric.

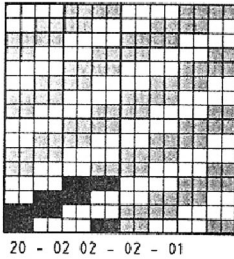

Pattern Draft

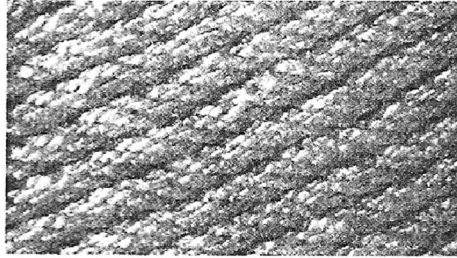

Flattened twill

Usually, the weft floats are longer than the move number which, in turn, is greater than one.

Twill, left handed: In a regular twill adjacent picks never float over or under the same set of warp ends. If the first two ends of a 2/1 twill are lifted for the first pick, then the second and third ends may be lifted for the second pick and the first and the third ends lifted for the third pick. Likewise, if the twill is woven as $\frac{1}{2}$ twill, the first end is lifted for the first pick followed by the second and then the third if we maintain in the same direction. Twills may progress to the left or right. The former is called a **left handed twill** and the latter is called a **right-handed twill**.

Twill, steep: With equal densities of warp and weft, the simple twills display a twill line of about 45. A steep twill line can be obtained either by increasing the relative density of warp or by using a move number of two in the pattern, or by special constructions.

Twill, uneven: See **Twill, even**. When the number or sum of numbers above line and the number or the sum of numbers below the line it is called an uneven twill. The warp shows more on one face and the weft on the other face. Because the number above the line is not equal to the number below the line a three-shaft twill is an uneven twill.

Twills, right handed: See **Twills, left handed**.

Twill, waved: By changing the direction of the twill line at regular intervals a wave, or zigzag effect can be created either across the fabric or along its

length. Diamond checks can also be made. The twill lines come to a point at the reversals.

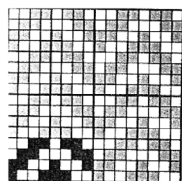

Pattern Draft

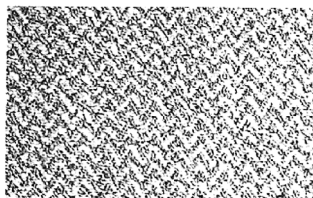

Waved twill

Twills: Materials with the twill structure.

Twilo process: A spinning process in which yarn is made by binding fibres with an adhesive, then removing the adhesive after the yarn is made into fabric.

Twilo yarn: A twist-free yarn, ribbon-like in appearance (viscose staple fibre, HWM-, polynosic fibres) of good uniformity from wet-drawn fibre bundles, bonded with hot-water soluble adhesive or polyvinyl alcohol binding fibres (5–11% by weight). The fabric possesses substantial covering property. Once the binding agent is washed out the yarn strength in the fabric decreases. Twilo yarns possess good strength, covering property, softness, sheen properties.

Twine: (1) A term applied loosely to a variety of textile strands used for tying such articles as parcels, bundles, bales etc. (2) An aggregate of fibres or yarns compacted into a partially or completely balanced twisted structure of indefinite length, generally used for tying or binding.

Twist, in textile strands: The helical or spiral configurations induced by turning a strand about its longitudinal axis.

Twist: The number of turns about its axis per unit length observed in a yarn or other textile strand.

Twist: Durable plain or twill worsted fabrics, often made with multicoloured folded yarns for a speckled effect. Used for jackets, trousers and suits.

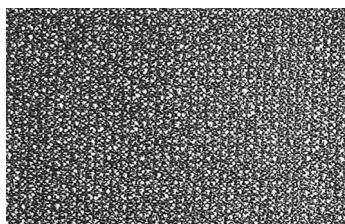

Twist: (a) The spiral disposition of the component(s) of a yarn and that is usually the result of relative rotation of the extremities of the yarn(s).

(b) The number of turns per unit length of yarn, e.g. turns per metre.

NOTE:

Twist Designation:

- (i) Twist in Single Yarns
 - S twist
 - Z twist
- (ii) Twist in Folded Yarns
 - ZS twist
 - SZ twist
 - ZZ twist -on-twist (q.v.)
 - SS twist -on-twist (q.v.)
- (iii) Twist in Cabled Yarns
 - ZSZ twist (formerly “cabled twist”)
 - ZZS twist (formerly “hawser twist”)

The first symbol designates the direction of twist in a single yarn, the second symbol designates the direction of twist in the folding operation, and the third symbol the direction of twist in the cabling operation.

Twist direction: See **Twist, direction of.** The twist of spun yarns denotes the amount of twist applied to a yarn (twist) to fix the bundle. The direction is denoted by S- (right-hand) and Z-twist (left). If the direction of inclination of the fibres appearing at the surface of yarn (or of the single components of a



folded yarn) is to the right, when the yarn is held vertically, then it is called Z Twist and when it is to the left it is called S Twist. The number of turns (degree of rotation) relating to 1 m yarn length (T/m) depends on the fineness, raw material and ultimate application of the yarn to be spun and the spinning process. The relationship between twist, raw material and fineness is expressed by the formula $T/m = \alpha_m R(Nm)$.

Twist Fabric: A plain knitted fabric, each loop being twisted as it is formed.

Twist factor: The product obtained when the twist expressed in turns per centimeter is multiplied by the square root of the yarn number expressed in tex.

Twist multiplier: The quotient of the twist expressed in turns per inch and the square root of the yarn number in an indirect system.

Twist of spun yarns: See **Twist, Twist direction.**

Twist factor (Twist multiplier): A measure of the “twist hardness” of a single yarn, determined by the multiplication of the turns per unit length by the square root of the linear density of the tex system.

Typical twist factors:

Fibre Length	Short	Medium	Long
Knitting	-	2400-2875	2010-2500
Weft	3150-3650	2875-3350	2400-2875
Semi-warp	3550-3830	3350-3650	2875-3260
Warp	3830-4790	3650-4300	3260-3750

Twist liveliness: The effect caused by unbalanced torsional forces in any yarn, and of sufficient magnitude to give rise to difficulties in processing or defects in the resulting fabric.

NOTE: Examples of this are snarling (see snarl) in processing and spirality (q.v.) in knitted fabric.

Twist on Twist: English mill parlance for yarns with especially elastic properties, the twist of the two-fold being the same as the twist of the single yarn.

Twist setting: A process for fixing twist in yarns to deaden torque and eliminate kinking during further processing. There are several methods that use steam to condition the packages of yarns.

Twist Stitch: Same as **cord stitch.**

Twist take up: The change in length of a yarn or other textile strand caused by twisting, expressed as a per cent of the original untwisted length.

Twist texturing: A texturing method in accordance with the mechanical/thermal principles; the two different processes are torsion crimping and friction texturing. The following phases are followed as a continuous process during manufacture:

- high-twisting,
- heating and cooling to fix the twist,
- down twisting (doubling).

The process is essentially based on the twist principle, although it is not only two (or more) yarns being twisted together, but a multifilament being twisted around its own axis. The high-twisted fibres are thermo fixed and the twist again applied. This gives rise to high bulk yarns.

Twist, balanced: See **Balanced twist**.

Twist, cable: See **Cable twist**.

Twist, contraction: See **Twist take-up**.

Twist, cord: See **Cord twist**.

Twist, corkscrew: See **Corkscrew twist**.

Twist, Direction of: See **Direction of twist**. The direction of twist in yarn and other textile strands indicated by the capital letter 'S' and 'Z'. Yarn has 'S' twist if, when the yarn is held in a vertical position, the visible spirals or helices around its central axis conform in the direction of slope to the central portion of the letter 'S' and 'Z' twist if the visible spirals or helices conform in the direction of slope to the central portion of the letter 'Z'.

Twist, final: See **Final twist**. The number of turns per unit length in a single yarn component of the plied yarn or the plied yarn component of plied yarn component of a cabled yarn as the component lies in the more complex structure.

Twist, hawser: see **Hawser twist**. The construction of a cabled yarn, cord or rope in which the single and first ply twist are in the same direction and the second ply twist are in the opposite direction and S/Z/S or Z/S/Z construction.

Twist, original: The twist in a single or plied yarn component of a plied or cabled yarn as the component was before incorporation in to the more complex structure.

Twist, set: To dissipate or render latent any unbalanced twisting moment of force in a yarn by suitable treatment such as steaming.

Twist, single: The amount of twist in each individual single yarn element in tyre cord structure based on the length of the element after the twist has been removed from the cord.

Twisted or laid rope: Rope made from three or more strands which are laid or twisted together in a twist direction opposite to the twist direction in the strands.

Twisted Multifilament Thread Construction: Thread made from continuous filaments of polyester or nylon that are twisted together into a cohesive bundle and then plied to make the thread.

Twist factor at break: See **Torsional strength**.

Twisting: (1) The process of combining filaments into yarn by twisting them together or combining two or more parallel singles yarns (spun or filament) into plied yarns or cords. Cables are made by twisting plied yarns or cords. Twisting is also employed to increase strength, smoothness, and uniformity, or to obtain novelty effects in yarn. (2) A very high level of twist is added to single or plied yarns to make crepe yarns. This operation generally is called creping or throwing. (3) The process of adding twist to a filament yarn to hold the filaments together for ease in subsequent textile processing, etc.

Twit: A short section of real twist in false-twist yarn that prevents crimp development and hence causes a pinhole effect in fabric. Also called twist bleed or tight spot.

Twitt: A term applied to yarn which is irregular, that is thick and thin, the thin places being below the count required and thick places above. The defect is caused by material being drafted at an irregular rate.

Twitty: Unevenly spun yarn.

Two bath pad-batch process: For reactive dyes. A semi-continuous principle: goods are padded with neutral dye solution, dried, padded with alkali and salt, batched up and given several hours' dwell time

Two bath pad-steam process: Another term for the Pad-steam process. A continuous dyeing process, in which the goods are padded in the 1st bath with dye, in the 2nd with the chemicals necessary for fixing, and then briefly (max. 60 s) fixed in steam. Examples: for vat dyes, caustic soda and sodium hydrosulphite, for reactive dyes a saline alkali or sodium silicate solution.

Two bath process: Working with two baths in series. For example, in the case of polyester/wool blends, the polyester content is dyed first in one bath, with over dyeing of the wool in a fresh bath. Opposite: Single-bath process.

Two Faced: See **Double Faced**.

Two phase flash age process: In this variation of the Two-phase printing process, goods printed with alkali free reactive dyes are fixed in a flash ageing plant which consists of a pad, preferably a Mini-Fluid, and a flash ageing steamer. Fixing involves application from the pad of either an alkaline saline liquor of varying composition or sodium silicate or a combination of sodium silicate and caustic soda.

Two phase mercerising process: A process whereby in the 1st phase cotton is impregnated with 24–25% caustic soda and in the 2nd phase with dilute alkaline solution of approx. 11%.

Two stage twisting: A system of producing a yarn, which consists of stage-1-Inserting a low level of twist into a yarn or yarns by ring twisting, stage 2-taking the product of stage 1 and up and twisting to insert the desired amount of twist.

Two tone effect: E.g. on fabrics (woven, knitted goods) which fashion requires should contain two colours (for more colours Multicolour effects), distributed evenly or randomly; e.g. jaspé, melange, vigoureux, changeant (two different-coloured yarns in warp and weft), thread-by-thread (double twill), mouliné twist.

Two-for-one twister: A twister that inserts twist at a rate of twice the spindle speed.

For example, at a spindle speed of 2,000 rpm, 4,000 turns per minute are inserted in the yarn.

Two-front button: A button in which the face and back shape are identical.

Two-phase flash-age process: In this variation of the Two-phase printing process, goods printed with alkali free reactive dyes are fixed in a flash ageing plant which consists of a pad, preferably a Mini-Fluid, and a flash ageing steamer. Fixing involves application from the pad of either an alkaline saline liquor of varying composition or sodium silicate or a combination of sodium silicate and caustic soda.

Two-phase printing process: The preferred method for vat dyes (Colloresine process; Flash ageing) and reactive dyes. Principle: print on the printing dye paste, dry, pad with fixing chemicals (for vat dyes: alkali + electrolyte), then steam, usually without interim drying (100–140°C, 20 s up to 8 min) and wash. Particular advantages include: unlimited fastness of the dye pastes and prints on printed materials, extremely quick fixing of dyestuffs, low energy consumption for fixing. Disadvantage: high chemical consumption.

Two-phase vat discharge prints The discharge dyeing of direct and reactive dyed backgrounds using vat dyes is only possible using the classic vat printing method with sodium formaldehyde sulphoxylate, which requires long fixing times; with two-phase vat discharge printing the advantages of the Two-phase printing process can also be of benefit to discharge printing. The goods to be printed are padded with reactive dye of the alkali free vinyl sulphone type, dried, and then overprinted with vat-dye paste, which, apart from the dye, only contains formaldehyde sulphoxylate. The alkali necessary for both dye types is padded on and the discharge print completed using the Twophase flash ageing process. The desired rapid decomposition of the formaldehyde sulphoxylate is achieved by a heavy metal complex catalyst, e.g. cobalt dimethylglyoxim, which is added to the printing dye paste.

Two-phase wet fixation process: Hoechst system), for reactive dyes (Wet fixation process, Caustic shock process). Fixing in the two-phase wet fixation process is carried out in the wet fixation trough, a simple, inexpensive device, available in various sizes. The fixation liquor, consisting of a strong alkaline saline solution or, as has proved preferable, 600 ml sodium silicate 38–40°Bé and 200 ml 33% caustic soda, heated indirectly to 95–105°C. Fixation of the goods under these conditions takes approx. 10s.

Two-sided effect: In the case of textiles made from blended fibres, provided two-tone or Multicolour effects are not required, all fibres are dyed by means of tone-in-tone dyeing. Otherwise the goods would have an uneven appearance. In the case of certain fabric types, each side of the fabric has a different shade.

Two-sidedness: See **Two-sided effect**.

Two-tone effects: E.g. on fabrics (woven, knitted goods) which fashion requires should contain two colours (for more colours Multicolour effects), distributed evenly or randomly; e.g. jaspé, melange, vigoureux, changeant (two different-coloured yarns in warp and weft), thread-by-thread (double twill), mouliné twist.

Tying-in: The tail end of the exhausted weavers beam is tied to the beginning of the new warp. If every end of the new beam is tied to the corresponding end of the old beam, the drawing process can be omitted. Following the tying-in process, all knots are pulled through the drop wires, heddles and the reed. The loom is ready for operation.

Tying: on the warp usually refers to the tying of small groups of warp threads to the front apron rod.

Type I Apparel (AATCC): Apparel defined for general heavy work; it may be subjected to breaking and tearing stresses, indoor or outdoor.

Type II Apparel (AATCC): Apparel designed for light work or leisure activities; it will not be expected to undergo severe physical stresses.

Typha fibres Strong, woolly fibres belonging to the Bast fibres group, obtained from the leaves of the reed mace. Only of localised significance. Spun alone, or (usually) with flax (tow), jute, recovered wool, etc. Used as a replacement for jute and hemp, or for coarse woven fabrics.

Typp: An obsolete yarn numbering system. The number of 1000 yard lengths of yarn per pound.

Tyre bead: That part of a tyre that comes in contact with the rim and that is shaped to secure the tyre to the rim.

Tyre bead wire: A monofilament steel wire with a metallic coating, usually bronze, used in forming a tyre bead.

Tyre builder fabric: Fabric consisting of tire cord in the warp with single yarn filling at extended intervals.

Tyre construction: The geometry of the various layers of tire fabric in the final tyre.

Three constructions are commonly used. (a) **Bias Tire:** In this construction, tire fabric is laid alternately at bias angles of 25 to 40° to the tread direction. An even number of layers (or piles) is used. (b) **Radial Tire:** In a radial tire, tire fabric traverses the body of the tire at 90° to the tread direction. Atop the tire fabric are laid alternating narrow layers of fabric at low angles of 10 to 30° to the tread direction; the belt that is formed around the tire body restricts the movement of the body. (c) **Bias/Belted Tire:** This tire construction combines features of the preceding two. The first layers of fabric are identical to the bias tire. The belt is added in alternating layers at 20° to the tread direction.

Tyre cord: A twisted or formed structure composed of two or more single or plied industrial yarn elements having the same nominal twist, direction of twist, length, and tension.

Tyre cord fabric: A fabric consisting of tyre cord warp with widely spaced single yarn weft. A loose fabric woven to facilitate large-scale dipping, treating, and calendaring of tyre cords. Usually, 15 to 35 tyre cords per inch of warp are woven into a tyre fabric by 2 to 5 light filling yarns per inch. In these fabrics, the strength is in the warp and the filling only holds cords in position for processing. The filling yarns are normally broken during tyre molding. The warp cords are polyester, rayon, nylon, aramid, glass, or steel and range in strength from 30 pounds to over 100 pounds per cord. A 60-inch fabric would normally have a warp strength of about 7,000 pounds. Such fabrics are used for tyre carcasses and tyre belts. More conventional square woven fabrics are used in certain parts of a tyre such as the bead, chafer, and wrapping. (Also see **Tyre cord**.)

Tyre-builder fabric: See **Fabric, tyre builder**.

Tyrian Purple: Red dyestuff, yielded by several species of the murex, a snail in the Mediterranean; used extensively and highly prized by the ancient people. Tyrian purple. A purple colour obtained from certain shell fish, such as *Buccinum* and *Purpura*. It is mentioned by Pliny as being discovered in 1400 BC. It was a lost art in the Middle Ages.

Tyrlind Striped: French dress goods, made with silk warp and heavy schappe filling, forming cross ribs.

U

U.L. Down: ‘Ultra Light Down’ is used in women’s and men’s jackets. The concept is to make the lightest and warmest insulation layer available. U.L. Down jackets weigh less than a t-shirt, blocks more wind and is warmer than even the heaviest fleece jackets and compress to the size of a water bottle. This outerwear can be used when warmth is critical, minimal weight is paramount, and space is at a premium.

Ulang: In the Chinese markets, stout and strong worsted satins.

Ulster: (1) The name often used to describe a heavy overcoat, but it is in fact the name of a thick cloth napped on the right side. The pile is flattened, but still lies in one direction. Once often used for men’s and women’s traveling cloaks, but now mainly confined to men’s overcoats. A classic ulster is double-breasted; modern sport and short ulster are single-breasted.

(2) A heavy, fulled and rough woollen winter coat material of coarse yarn (often pure virgin wool, but also an admixture of shoddy and rayon) with a Melton finish; usually with a woven-in lining, named after an Irish province. The weave of the outer fabric is usually twill and herringbone; that of the inner fabric is 4-ply evenly spanned twill.

Ultimate oxygen demand(UOD): Either the *theoretical oxygen demand* or the ultimate biochemical oxygen demand, the maximum value of the BOD test, ordinarily reached after 25 to 30 days’ incubation. The UOD is the sum of the ultimate *carbonaceous BOD* and the ultimate *nitrogenous BOD*.

Ultracentrifuge: Used in colloidal chemistry to determine molecular weight and sedimentation rate of particles suspended in either liquids or gases. It can attain a centrifugal force of 260,000 to 1 million g (motor driven at approximately 30000 rpm).

Ultrafiltration: A membrane extraction process (Permeation) using membranes or cellulose film applying hydrostatic pressure difference to separate colloiddally dispersed dissolved substances from molecularly dispersed substances and macromolecules, colloids, most bacteria, some viruses, proteins. Pore diameter from 02–50 nm. Typical operating range will be 0.005–0.200 um. Ultrafiltration is suitable for cleaning waste water from the dyeing and textile industry.

Ultra-light weight: Term used to describe a fabric used in outerwear, which allows for a minimum pack volume and weight. Lightweight packable garments offer the most versatile weather protection. Some of these fabrics have a protective layer on the membrane, which provides durability. This means that the garments made from extra lightweight fabrics need no separate lining.

Ultramarine (-blue, blue powder, washing-blue): Mineral dye obtained by heating together kaolin, sodium carbonate, sulphur and charcoal. A fine brilliant blue powder (of variable composition), also blue-green, violet and red. Insoluble in all solvents.

Usage – component of white conditioner in printing; frequently used in the blueing of bleached goods, underwear, feathers, etc.; dyeing of plastic, rubber, wax cloth, leather, paper; as marking dyes, etc.

Ultra-sonic: Higher than audible sound with a frequency above approximately 16 kHz up to approximately 106 kHz. Infrasound up to 16 Hz; audible sound 16–16,000 kHz; ultrasound above 16,000 Hz. Ultrasonic is a specialist area of more general acoustics which studies the behaviour of mechanical oscillations in solid, liquid and gaseous media (sound). In reference to the characteristics of the human ear, high frequency and no longer audible oscillations are termed ultrasound or hyper-sound.

Ultraviolet: A form of electromagnetic radiation, shorter in wavelength than visible light. Like light, ultraviolet radiation is produced by electronic transitions between the outer energy levels of atoms. However having a higher frequency, ultraviolet photons carry more energy than those of light and can induce photolysis of compounds and photoionization. Light that is just beyond the visible portion of the light spectrum at the blue end. It is primarily ultraviolet light that is responsible for fading of colours, and that makes fluorescent compounds glow. Longwave ultraviolet, “blacklight”, with a wavelength of around 365 nano-meters, is the preferred source for exposing many photosensitive materials such as silkscreen emulsions. It is also useful for inspecting fabrics to detect optical brighteners. Longwave UV sources can be found in the form of fluorescent tubes. Tubes that appear white when off also emit considerable visible light and are best as exposure sources. Tubes that appear very dark purple don’t produce much visible light and are best for inspection sources. The dark purple type can often be purchased at novelty shops. “Germicidal” lamps are shortwave UV emitters. This wavelength, typically about 254 nano-meters can cause eye damage. In one classification system, the ultraviolet spectrum is referred to by three wavelength classes: UB-A (315–400 nm), UV-B (280–315 nm) and UV-R (280–400 nm). Ordinary

glass is fairly transparent to longwave UV, but nearly completely opaque to shortwave UV. Quartz is a much more effective material for making lenses and prisms for use with ultraviolet. See also **Electromagnetic radiation**.

Ultraviolet curing of polymers: Polymer systems capable of being cured by irradiation need not have a complex structure and may comprise of only a single chemical substance. For reactive components such as acrylates, the energy level of accelerated electrons is high enough to begin radical polymerization. However if UV light is used as a source or irradiation, a photo-initiator is usually required in order to generate sufficient radicals to start the polymerization reaction.

Ultraviolet degradation: Weakening or deterioration caused by exposure to ultraviolet rays of sunlight or artificial light.

Ultraviolet fluorescence of textiles: Fibres emit fluorescence in the ultraviolet region, e.g.

Faintly yellowish, whitish (USA)	cotton
Pale yellowish	cotton, mercerised and bleached
Straw yellow	viscose, unbleached
Sulphur yellow with blue shadow	viscose, bleached
Intense yellow	polyester
Yellowish green polyacrylonitrile	
Blue-green	polyvinylchloride
Bluish violet, brightly luminous	acetate
Reddish white, milky	cuprous
Bluish white	wool, unbleached; silk, scoured; casein
Pale bluish, whitish	wool, bleached.

Ultraviolet lamp (quartz lamp, quartz-mercury lamp, mercury lamp): Artificial source for the generation of ultraviolet radiation. For lamps used in analysis, the visible component of light from such sources is removed using a special filter.

Ultraviolet radiation (UV radiation): Includes light of a wavelength from approximately 140 nm to 360 nm. Ultraviolet radiation is present in sunlight but is nevertheless invisible to the human eye, since it lies beyond the violet portion of the visible spectrum.

Note: The limits of the spectral range of ultraviolet radiation are not well-defined and may vary according to the user. Committee E.2.1.2 of the CIE distinguishes in the spectral range between 400 and 100 nm

UV-A 315–400 nm

UV-B 280–315 nm

UV-C 100–280 nm

Ultraviolet resistance: Ability to retain strength and resist deterioration on exposure to sunlight.

Ultrasuede: Unbleached cotton.

Umbrella fabrics: A thick and light fabric (often printed) made from yarn-dyed polyamide threads and made water repellent.

UMIST: English textile research organisation in Manchester.

UNARI: Burmese Standardization Association.

Unbalanced colourways: When there is no similar colour relationship between colourways, giving the colourways a different appearance to the original design.

Unbleached: Cotton and linen fabrics, left in the natural “grey” state.

Unbleached linen (Écru linen, raw linen): Naturally coloured, unbleached.

Unboiled silk: See **Ecru Silk**. Ecru silk (bast silk) is barely degummed silk (maximum 4% loss) – only grease, wax and resinous substances removed.

Unbonded batting: A textile filling material which is neither needle punched, resin bonded, nor thermal bonded.

UNCO: Una Norma Colombiana, Colombian Standard.

Uncollapsed cake: Rewound cake in crossed layers of yarn, mechanically stronger with improved dyeing characteristics (package and pin up system).

Uncut pile fabrics: Pile fabric before cutting the piles.

Underarm length (in body measurements): With the arm down, the distance from the armpit to the inner wrist bone.

Undercoat hairs (down hairs, wool hairs): Shorter and finer hairs forming the inner layer of an animal’s coat, usually unmarked, soft/elastic, curled with good felting quality.

Undercoat: The body-coat.

Undercollar: The underside of a collar; usually, but not necessarily, of softer material.

Underlap: This is the other section of stitch in a warp knitted fabric. The yarn is horizontal and appears at the back of the fabric. It can cover 14 needle spaces or more, depending on the design of machine and fabric.

Underlay: A cushion or padding material used under rugs or carpets to give greater resiliency and longer service.

Under-press: To press the underside of a garment section during manufacturing to open the seams and give it shape.

Under-stitch seam finish: Under stitching is a second row of stitching sewn along the seamline crease on the inside edge of the garment or on the facing edge. It helps to hold the seam allowances in place and keep them from rolling out which would flatten the edge of the garment. Used for neckline areas, on under collars, on cuff facings, on the backside of lapels, on front edge facings or any areas where a sharp seamline crease needs to be maintained.

Undertone: Each hue has an undertone which is its underlying primary colour. It is the undertone of a hue that determines its temperature. A blue undertone gives a hue a cool bias and a red one gives it a warm bias. Each hue can have either a warm or a cool undertone, regardless of the actual hue. Therefore blue, although generally a cool colour, can have a warm bias if the undertone is red. This is also true of the warm hue red, which with a blue undertone becomes cool. Thus each primary hue can have a warm and a cool variation.

Underwear: Clothing worn next to the skin under outer clothes. Underwear is intended to absorb the moisture emanating from the skin through perspiration and release this to the outer air. If the rate of absorption is greater than that of evaporation, the textile remains wet against the skin and this leads to an unpleasant sensation.

Undrawn tow: Tow which is not undergone drawing process. Tow fibre is similar to staple but it is cut up at a later stage in production than staple. The short fibre stock of varying lengths removed in breaking, scutching, hackling, or combing.

Undrawn yarn: Extruded yarn (filaments), the component molecules of which are substantially unoriented. Undrawn yarn exhibits predominantly plastic flow in the initial stages of stretching and represents an intermediate stage in the production of a manufactured yarn.

Undulated twills: Twills with curving diagonal lines are called undulated twills and can be made using four shafts.

UNE: Spanish Standards Association.

Uneven dyeing: Cloth which shows variations in shade due either to incorrect dyeing methods or faulty materials.

Uneven dyeing for fashion effects: Either intentionally dyed unevenly as per requirements of the fashion or make uneven appearance of dyed fabric

by mechanical or enzyme treatments or other methods. Example is faded, or vintage look in Jean materials.

Uneven shrinkage: A wavy, warp-wise condition in the fabric that prevents it from lying flat on a horizontal surface.

Uneven surface: An irregular surface characterized by non-uniformity in the physical configuration of the yarns or fibres making up the surface of the fabric.

Uneven yarn: A yarn that varies in diameter to an abnormal degree.

Unevenness (in textiles): Variation in the linear density of a continuous strand or of a portion of a strand.

Unfinished worsted: Despite the name, it is not necessarily wool and is finished. It is characterized by a slight nap. It is a plain weave, heavy weight men's suiting and may be plain or check. Used for men's suits and women's heavy duty trousers.

Unfinished worsted: A worsted fabric with a relatively soft hand and a light nap.

UNI: Italian Standards Association.

Unidirectional fabric: A fabric having reinforcing fibres only in one direction.

Uniform cloth: Cloth suitable for uniforms; usually a stout, fullered, woollen cloth, similar to kersey.

Uniformity: The most important determining factor when assessing goods according to quality, e.g. in terms of pattern, finish, weight, length, thickness, section, strength, stretch, etc. Calculated as: % U (uniformity) = 100 – deviation in % (See **Deviation**).

Uniformity index (in fibre length testing of cotton): The ratio between the mean length and the upper-half-mean length expressed as a percentage of the upper-half-mean length.

Uniformity ratio (in fibre length testing with fibrograph): The ratio between two-span lengths expressed as percentage of the longer length.

Ungummed silk: Which has the natural gum removed by boiling in solution of soap.

Uni: French for single coloured or plain effect.

Union: The term has two meanings – (1) A fabric made from the union of two fibres, e.g. cotton and worsteds, or cotton and linen; (2) A striped fabric from two fibres and then dyed, the fibres taking the dye differently and therefore

producing a coloured stripe. This was often produced as a cheap, hard wearing cotton cloth and made into men's working shirts, worn with white cardboard or celluloid collars and cuffs which are removed at home.

Union braid: Worsted or mohair braid, made of more than two cords.

Union carpets: In England, double carpets with pile on both sides; held together by a binder filling.

Union cassimere: Soft and fulled fabric, made with cotton warp and woollen filling; has checks or stripes; used for men's cheap clothing.

Union cloth: A napped shoddy fabric, made with cotton warp in England.

Union cord: Stout, round cord made of cotton and linen; used for lacing.

Union damask: Made with cotton or linen warp and worsted filling, woven with satin figures over satin ground; used for hangings, etc.

Union dye: A dye that is a mixture of two or more different classes of dye; used typically to dye blends of fibres. "Household" dyes, of the sort sold in grocery stores, are usually union dyes containing a direct dye which will work on cellulose fibres, and an acid dye which will work on wool or nylon. Industrially the union dyes may be of the other combinations, such as reactive and disperse dyes for dyeing cotton-polyester blends (often with two distinctly different sub-processes).

Union dyeing: Dyeing of union fabric, i.e., fabric blends containing wool.

Union fabric: The blended fabric containing wool.

Union linen: Made with cotton warp and linen filling.

Union silk: A fabric made usually with cotton warp and silk filling; used as umbrella cloth.

Union yarn: Made of a mixture of cotton and wool.

Unisyn concept: Universal desizing technique for water soluble synthetic size. Water soluble sizes of all types can be washed out cost effectively on a continuous wash production line by using the Unisyn technique (BASF) with the application of

1 g/l wetting agent,

2 g/l dispersing agent,

3 g/l sodium hydroxide.

UNIT: Instituto Uruguayo de Normas Tecnicas, Uruguay Institute for Technical Standards.

Unit sampling (in wool): A portion of material that is taken at one time from one physical location and that is combined with similar portions to make up the laboratory sample.

Universal indicator (multiple-range indicator): A mixture of indicator dyestuffs which shows a gradual change in colour over a wide pH range. A typical formulation contains methyl orange, methyl red, bromothymol blue, and phenolphthalein and changes through a red, orange, yellow, green, blue, and violet sequence between pH 3 and pH 10. Several commercial preparations are available as both solutions and test papers.

Unlevel dyeing: Faults occurring in the dyeing of textiles of all varieties. The dyestuff is not levelled (levelling properties), but instead is spread unevenly over the textile material. Unlevel dyeing may be caused by, among others, any of the following factors: omitted or inadequate pre-treatment, packing too tightly in apparatus, a too weak or a too strong dye bath circulation, inappropriate or faulty dyeing conditions and inappropriate choice of dye.

Unlevelness: The absence of levelness in the dyeing or printing or any other process. See **Unlevel dyeing**.

Unopened staple: Staple fibre in bunches or clusters in the bale in such a condition that it will not process smoothly through carding and subsequent operations in the spun-yarn plant.

Unroved: Unravelled.

Unrelaxed yarn: Yarn in which the tension during the manufacturing process has not been released. The relaxation is done usually by steaming.

Unsaturated steam: Superheated steam. Steam may be either saturated or superheated.

Saturated steam is a vapour and, at a particular pressure, has a definite temperature, the saturation temperature. Superheated steam is a gas and, at a particular pressure, may have any temperature in excess of the saturation temperature.

Unsupported needle felt: A needle felt that is composed entirely of fibres physically interlocked and reoriented with, and of themselves without an interlay, scrim or extruded structure.

Untreated: A descriptive term for glass fibre yarns having no applied chemicals or coatings, other than the minimal lubricant or binder used to control intra-fibre abrasion.

Updraft metier: A dry spinning machine in which the air flows within the drying cabin and is counter current to the yarn path (upward).

UPF (Ultraviolet Protection Factor): The UPF rating indicates how effective a fabric is at blocking out solar ultraviolet radiation from reaching the skin. UPF ratings range from 15 to 50 with higher ratings indicating more effective blocking and therefore better protection for the wearer of a garment. Fabrics that test higher than UPF 50 are rated as UPF50+. UPF testing involves the process of exposing a fabric to ultraviolet radiation (UVR) and measuring how much radiation is transmitted through the sample. Different wave-lengths of radiation in the UVR spectrum have different effects on human skin and this is taken into consideration when calculating the UPF rating. Factors that contribute to the UPF rating of a fabric are as follows:

- (1) Composition of the yarns (cotton, polyester, etc.)
- (2) Tightness of the weave or the knit (tighter improves the rating)
- (3) Colour (darker colours are generally better)
- (4) Stretch (more stretch lowers the rating)
- (5) Moisture (many fabrics have lower ratings when wet)
- (6) Condition (worn and faded garments may have reduced ratings)
- (7) Finishing (few fabrics are treated with UV absorbing chemicals)

Upholstered furniture: Furniture covered with such materials as textiles or leather and generally with padding or cushions or both.

Upholstery crepe: A woven crêpe made from cotton, usually printed.

Upholstery fabric: The exterior fabric covering applied to a furniture unit; it can be woven, warp-knitted, raschel-knitted fabrics and stitch-bonded fabrics in wool, polyamide, polyacrylonitrile, cellulose and blends.

UPN: Urad pro Normalizaci a Mereni, Prag; Polish Office of Standardization and Metrology.

Upper-arm girth (in body measurements): The maximum circumference of the arm usually midway between the elbow and the shoulder joint.

Upper-arm length (in body measurements): With the arm bent, the distance from the shoulder joint along the outside of the arm usually midway between the elbow and the shoulder joint.

Upper-half-mean length (in fibre length testing of cotton): The mean length by number, of the longer one half of the fibres by weight.

Upper quartile length, in testing of cotton fibres: That length which is exceeded by 25% of the fibres by weight in the test specimen.

Upright pile finish: Plush fabrics with pile made from cotton fibres are impregnated with synthetic resin, brushed, dried and set. The pile stands up again after being pressed down.

Upright pile velvet: Raised fabric with velvety appearance. The napped fibres stand vertical (opposite Nap velour). See **Pile lifter**.

Uptwister: A machine used for twisting yarns in an upward path from a rotating vertical supply package to a horizontal take-up package. Used for spun yarns and to a small extent for adding twist to a few filament yarns.

Uptwisting: The process of twisting yarn on the uptwister. The yarn to be twisted, which has been wound on a balanced support package, is placed on a revolving spindle. The yarn from the revolving supply package is fed upward through a gathering eye or guide, over a stop motion and a tension bar or bars, through a traversing guide, and onto the revolving collecting package.

Urban Tool's Groove Rider: Austrian Urban Tool Company has already commercialized iShirts which have a pocket made with elastic fabric for a mobile phone or iPod, so the devices won't slip out. A recently developed product is a shirt with a music player controlled by a smart fabric touchpad. The smart fabric touchpad is one of ElekTex's technology products (Comprehensive Merchandising Support, 2007).

Urea: An organic nitrogen compound (NH_2CONH_2). Urea is used in dyeing for a number of purposes. Urea helps increase the limit of solubility of few dyes, such as MX, in water. This can be useful when strong solutions are to be made for tie-dyeing. From 5% to 20% w/v can be used. Urea is used as a humectant. In tie-dyeing or similar processes, it helps prevent fabric from drying out during the long periods when it is left in the open for the dye to fix. Urea increases the swelling of fibres and can break hydrogen bonds, aiding penetration and mobility of dye. Large amounts of urea, up to 30% w/v, are used in some cold pad-batch dyeing processes for wool. Most urea sold is synthesized from natural gas (Urea is sold as an "organic nitrogen" fertilizer. Pure urea will be designated 46-0-0 when sold as such).

Urea formaldehyde compound: The reaction of an amide -N-H with HCHO to form a -NCH₂OH is often termed Methylolation because the reaction product is called an N-methylol group. Accordingly urea can be methylolated with up to 4 moles of formaldehyde and the reaction products used as crease resistant finishes. When 2 moles of HCHO are reacted with one mole of urea, dimethylol urea is formed. Being di-functional, it is capable of serving as a cross-linking agent.

Urea formaldehyde resin: See **Urea formaldehyde resin**.

Urea free printing (urea in textile printing): Dye manufacturers try to replace urea as a hydrotropic agent with low molecular surfactants. Since the spray technique, using rotor damping may in the meantime be described as

technically dated. The use of this device has proved to be more successful than a print steamer on a semi-technical scale in order to fix reactive prints on viscose without using the waste water problematic urea. In normal setting, yields of 60% effectively fixed dye (referring to the dye used, the K/S value is = 100%) the best colour yields are achieved at approximately 30% rotor damping before entering the steamer.

Urea/Formaldehyde (U/F): See **Urea formaldehyde compounds**.

Urease: Urea-breaking enzyme, belonging to Hydrolases; Amidases. Gradual degradation into ammonia and carbonic acid results with water absorption: in which partially decaying ammonium (hydrogen) carbonate forms again. Urease was of great importance in wool finishing with urine (wool washing, indigo vat). Manufacture in purely crystalline state from the jack and soya bean since 1926. 1 g of urease splits almost 60 g of urea in 1 min at 20°C. Urease is inactivated by low quantities of heavy metal ions (Cu) (immobilization of active groups through complex formation), which can be reversed again by adding cyanides or hydrogen sulphide.

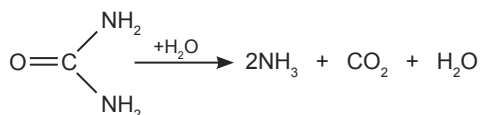

Urena fibres: Bast fibres (e.g., aramina fibre, congo jute) from many tropical countries (Brazil, Madagascar), similar to Rosella as a jute substitute.

Urethane: The name of a group of organic chemical compounds or resins built from isocyanate, a very reactive material that liberates gas during reaction to produce foams of various types. Two types of compounds that react with isocyanate to form foam are polyesters and polyethers. Polyurethanes are used for foams and in other compounds in fibre form. The polyester variety should not be confused with polyester fibres. See **Spandex fibre**.

Urethane elastomer: Polyurethane elastomer fibres.

Urethane group: Basically weaker compared with the Carbamide group (–NHCO), affinity only to disperse and selected acid dyes (below pH 2).



Urethanes (carbamates, ester amides): CO(OR) (NH₂), the compounds of carbonic acid intended here can be interpreted as esters of Carbamic acid. Due to their chemical relationship to urea they are called urethanes (of Urea), whose structural principle is represented in Polyurethanes.

Urquhart: A Highland tartan, composed as follows: Dark green stripe, split in the centre by a very narrow black stripe; black stripe, less than one third of the green; dark blue stripe, wider than the green, split by a red stripe in the centre (one-sixth the width of the blue) and by a pair of very fine black lines near each edge.

Useable area (carpet): Useable layer in fitted carpets; the surface of fitted carpets needed in use.

Use-surface (for pile yarn floor covering): That part of a textile floor covering directly exposed to the traffic.

User based (in quality testing): In this definition, quality is considered to be an individual matter and the highest quality products are those that best satisfy the customer's preferences. The drawback of this definition is that the consumer preferences vary widely so that it is difficult to aggregate these preferences into products that have sufficiently wide appeal.

USP (A.P.): United States of America Patent (American Patent).

USS: United States Standard.

Uster tester: An instrument that provides a continuous measurement of the variation in weight per unit length of sliver, roving, and yarn.

Usuji Sofu: Light weight and plain woven cotton sheeting made in Japan.

Utility percale: See **Percale**.

Utility stitches: These are the basic stitches found on a sewing machine which are used to sew seams, hem, insert zippers and elastic. Examples of utility stitches are the straight stitch and zig-zag stitch.

Utrecht velvet: A hard wearing upholstery velvet. The base cloth is closely covered with the pile which is arranged so that there is no gap.

UV absorber: Polymer additives that absorb light in the UV region or that trap radicals produced in fibre during photo-oxidation. They provide stabilization against actinic degradation. Some critical applications include geotextiles, recreational surface polymers and fibres, tenting tarpaulins, etc.

UV degradation: The breaking down of fibres or fabrics when exposed to ultraviolet rays.

UV fluorescent dye: Fluorescent dyes in combination with UV irradiation. Application – UV marking pen is used for the invisible labelling of material faults and pre-programmable material positions (combination using UV irradiation), also for valuable fabrics (carpets, fleeces, furs, etc.) for invisible sighting using recognition features. Constructed on a wax basis and in the

form of Retouching pencils. The fabric spot to be marked must be ironed so that UV dye penetrates into the fabric. Chiefly used for wool and wool blend fabrics, as cotton and synthetics do not absorb any wax.

UV lamp: Ultra Violet Lamp

UV radiation: Ultraviolet radiation.

UV-A type fluorescent UV lamp: A fluorescent UV lamp where radiant emission below 300 nm is less than 2% of its total light output.

UV-B type fluorescent UV lamp: A fluorescent UV lamp where radiant emission below 300 nm is more than 10% of its total light output.**Union linen lawns:** As the name implies, these are made of cotton and linen yarns. The cotton in most cases forms the warp and linen as filling. Union linens are plain woven fabrics made in various textures with regard to ends and picks per inch, and also the quality and counts of yarn. The goods are used for various purposes, principal among which are furniture coverings, summer outing suits and dusters.

Upcycling: Using waste textiles, either pre- or post-consumer, and adding value to them by printing or stitching, and making them into new products.

V

V-bed flat-knitting machine: A latch-needle weft-knitting machine with two needlebeds at a 90° angle to each other in the form of an inverted V. Each needlebed is at a 45° angle to the horizontal. These machines are used primarily to produce collars, sleeves, sweater strips, and rib trims.

Vacuole: (Lat.: vacuus = empty), a cell cavity found especially in plant and algal cells, including vegetable fibres, which takes up a large part of the cellular volume; fibre cavities, intermicellar regions.

Vacuum: (Lat.: vacuus = empty), virtually air-free space, negative pressure. Although, literally, a vacuum is defined as a space totally devoid of any matter, which does not exist on earth, the term is used loosely for an enclosed space within which the pressure of a gas or air lies below that of air at the normal atmospheric air pressure of 1 bar.

Vacuum (v): To clean using an electrically powered machine to create suction in order to remove loose, particulate soil and lint.

Vacuum Breaker: A ventilating valve for steam heated equipment (e.g. feed water tanks) to protect the tank/unit against the build-up of excessive vacuum pressures. A vacuum is formed, e.g. in the feed water de-aerator by the choice of superheated steam to raise the water temperature and introduction of cold water at the same time, due to condensation of superheated steam which is still present. To prevent the build-up of excessive vacuum pressures, therefore, a flow of air into the de-aerator must be ensured by a suitable device as soon as a negative pressure develops in order to equalize the pressure.

Vacuum Drier: This type of drier is based on the principle of a Suction-drum drier and has been designed particularly for drying yarn on packages or in the form of hanks at temperatures of only 40–70°C. The 3-phase vacuum drier works intermittently by alternating cycles of heating up under pressure and evacuation to allow vaporization at a lower boiling point.

Vacuum Dyeing: Fibres from which all the air has been removed in a vacuum wet out more rapidly and a draw roller. In the suction cap zone, air is removed from the fabric by a vacuum of 3325 Pa. The cap is sealed against the rotating draw roller. Sealing of the suction cap and the liquid vacuum pump ensure a constant vacuum of 3325 Pa is maintained even during continuous

operation. For fabric entry, the vacuum cap allows the fabric to leave the draw roller approx. 170 mm horizontally. The resultant impregnated fabric is squeezed off in the nip of a 2-bowl padder with deformation-resistant bowls. Up to 30% higher liquor pick-up is possible with vacuum impregnation.

Vacuum Extraction Of Piece Goods: Surface water adhering to woven fabrics is easily removed through suction extraction by exploiting the principle of gas kinetics with the aid of a vacuum. In this process, the wet fabric passes over a suction slit

Vacuum Extractor For Yarn Packages: A device for extracting water from yarn packages with a branch circuit to a vacuum station and an interrupter valve. The rapid intermission frequency developed by the latter produces shock-like suction pulses which entrain the bound water. Residual moisture content after extraction is approx. 100%.

Vacuum Extractor in padding: An impregnation technology for applications on the padder which removes the air present in the fibre's intercapillary spaces by means of a vacuum (3325 Pa) immediately before entry into the liquor

Vacuum impregnation: An impregnation technology for applications on the padder which removes the air present in the fibre's intercapillary spaces by means of a vacuum (3325 Pa) immediately before entry into the liquor. After leaving the liquor, the fabric enters the air again. The penetration of liquor is more rapid and complete due to the extraction of air before immersion.

Vacuum impregnator: A machine used for vacuum impregnation. See **Vacuum impregnation.**

Vacuum Mercerisation: Vacuum treatment during mercerization. See also Vacuum treatment during mercerization.

Vacuum Plated Button: A button that is flash metal coated in vacuum chambers and subsequently coloured to simulate other metal finishes.

Vacuum sieving machine: A Print paste sieving machine which operates on the vacuum principle.

Vacuum Strainers: Strainers used for thick solutions which normally does not filter with gravity force. Very commonly used in filtering printing pastes, vacuum applied outside the filter mesh which forces the paste to pass through it.

Vacuum Suction Device: An open-width suction unit designed to reduce the liquor content of a textile fabric before drying, and before or after the application of chemical liquors (wet-on-wet treatment) for the removal of unbound water. Savings in drying energy are achieved. Vacuum suction units

can also be retrofitted to existing machines. The use of an under liquor vacuum suction unit allows, e.g., the desizing of tightly woven airbag fabrics.

Vacuum Transfer Printing Machine: The objective of this type of transfer printing machine is to achieve higher production speeds and improved print quality. It is essential that the air-permeable stainless steel conveyor, textile fabric and transfer paper are transported together before entry into the vacuum zone in order that the fabric passage can be checked and corrected if necessary without any intervention in the vacuum zone.

Vacuum treatment during mercerization: Immediately before impregnation, entrained air is evacuated from the textile material which allows cold NaOH liquor to be forced into the still unswollen interior of the fibres by external overpressure during immersion.

Vacuum yarn steamer: With automatic dosing of chemical additions. This type of steamer can be preprogrammed from 50–150°C in increments of 1°C with steaming times of 2–120 min (punched card controller).

Vagabundo Effect: In addition to the “stone wash” treatment of denim articles to obtain various effects (e.g. “snow wash”, “moon wash”, “gold wash”, etc.) as well as sand-blasting to produce a fine, velvety handle, another process designed to give denim articles a modish character has established itself.

Val Lace: See **Valenciennes Lace**, Short for of **Valenciennes Lace**.

Valencia vesting: A cloth for waist coats, woven with a cotton binder warp and a silk figuring warp with a worsted weft. It was popular in the early 19th Century.

Valenciennes Lace: A hand made flat type of Bobbin Lace. It is only made of linen thread, but cotton imitations are quite common. The lace is typified by the ground fabric, either roundmesh or diamond, and of the same thread as the decorative design.

Valonia: Acorn cups of certain species of oak from South Europe, containing 25–35% of tannic acid.

Valora: See **Velour**.

Value, in colour chemistry: Indicates the degree of lightness or darkness of a colour in relation to a neutral gray scale. The scale of value (or V, in the Munsell system of colour notation) ranges from 0 for pure black to 10 for pure white. The value scale is neutral or without hue.

van der Waals equation: An equation of state for real gases. For n moles of gas the equation is $(p + n^2a/V^2)(V - nb) = nRT$ where p is the pressure, V the volume, and T the thermodynamic temperature. a and b are constants

for a given substance and R is the gas constant. The equation gives a better description of the behaviour of real gases than the perfect gas equation ($pV = nRT$). The equation contains two corrections: b is a correction for the non-negligible size of the molecules; a/V^2 corrects for the fact that there are attractive forces between the molecules, thus slightly reducing the pressure from that of an ideal gas. See also **Gas laws**; **Kinetic theory**.

Van Der Waals Forces: Intermolecular forces as a result of localization of electrical charge within molecules or crystals named after the Dutch physicist and Nobel Prize winner, J. D. van der Waals (1837–1923). They vary inversely as the sixth power of the interatomic distance and are due to momentary dipoles caused by fluctuations in the electronic configuration of the molecules. A molecule considered as a whole is electrically neutral. Because of the way in which electrons are held, there may be local areas that appear to have positive or negative electric charge, either permanently or temporarily. These charges lead to attraction between molecules. Van der Waals forces are weak and easily broken, but they can be important in dyeing. They can be important in *affinity*, and hold dye molecules on the fibre near to where a much stronger bond may ultimately be formed.

Vanadium dichloride: (Vanadous chloride). VCl_2 , molecular weight 122. Derivation: from ammonium metavanadate. Used as a catalyst in the dyeing and printing of aniline black (in solution 1: 1000).

Vandyke: A pointed scallop in laces and embroideries.

Vandyke Stitch: In embroidery a raised couching in Vandyke points.

Vane, in feathers: The section that consists of a solid stiff collection of barbs, as distinguished from the section near the quill point that has soft fluffy barbs.

Vanillin(Poly) Ester Fibre: A polyester fibre produced from vanillin (3-methoxy-4-hydroxybenzaldehyde) derived, among other things, from wood lignin (1 kg wood gives 0.5 kg lignin), then converted to protocatechuic acid and subsequently to a condensable oxy acid with epichlorohydrin.

Vankye stitch: An embroidery stitch in the shape of the fishbone.

Vantean Process A finishing process to produce a high lustre on wool fibres. It involves a preliminary impregnation (mordanting) with a nickel catalyst which, after an intermediate wash, remains in the endocuticle. Subsequent chlorination is accelerated to such an extent that the exocuticle peels off resulting in a smooth fibre surface.

Vapeur: A very fine and loosely woven French cotton muslin.

Vapour Phase Process: See **Gas phase crosslinking**.

Vapour Pressure: The pressure exerted by a vapor. The saturated vapor pressure is the pressure of a vapor in equilibrium with its liquid or solid. It depends on the nature of the liquid or solid and the temperature.

Vaporloc system: The cloth in open width form is first saturated with sodium hydroxide solution (5-9%) along with wetting agent at 70°C padded and then entered into vaporloc reaction chamber which operates at 30 lb/in² (2 atm.) at a temperature of 134°C with a reaction time of 90–120 sec. The fabric is deposited on roller-bed system and thus allows the fabric to be in a relaxed state inside the pressure chamber. The fabric passes in between the low friction teflon material and the centre beam special seals enables the generation of necessary pressure inside the steamer. The cloth content inside the steamer is about 200 meters. The production speed is of the order of 120 m/min. The goods after scouring are washed off first with hot water and then with cold water.

Variable: A quantity to which any of the values in a given set may be assigned.

Variable data: Measurements which vary and may take any of a specified set of numerical values.

Variable Temperature Dyeing: Dyeing methods on the basis of drawing out at different dyeing- bath temperatures. Varying degrees of drawing effectiveness are demonstrated at individual temperatures, temperature ranges or stages, i.e. the substantivity, degree of fixation and drawing speed react differently in different temperature ranges. There are temperature stage-dyeing processes using increasing and decreasing temperatures.

Variable-Tension Rolls A system of rolls to adjust fabric tension by changing the wrap angle of the fabric around guide rollers or guide rods. When variable tension rolls are installed at the entry to a continuous processing plant, they are also sometimes described as the fabric feed system (consisting of 2 tubes only).

Variance: In Statistical analysis, variance is a measure of the dispersion of the distribution of a random variable. The square root of the variance is called the Standard deviation(s), and is the most widely used measure of variability.

Variant: A manufactured fibre modified in polymer configuration or by additive during manufacture, resulting in a change in the properties of the fibre. Examples are flame-retardant variants, deep-dyeing variants, high-tenacity variants, low-pilling variants, and cotton-blending or wool-blending variants.

Vase carpets: Oriental carpets with coloured representations of flower vases surrounded by palmettes and stylised floral motifs.

Vasquine: Thick, spongy fabric, made of Che fibres extracted from the pine needles.

Vat: (1) An alkaline sodium dithionite bath either without dye (blank vat) or with Vat dyes (dye vat). In the latter case, the vat dye is present as the soluble Leuco compound of the water-insoluble parent vat dye and is able to exhaust on the fibre in this form (Vat acids).

(2) The term “vat” was originally used to describe a wooden tub used for the fermentation of indigo.

Vat Acids: The leuco compound of a vat or sulphur dye which, in this (water-soluble) form, possesses affinity for the fibre. A vat acid is a very weak acid. Principle: all vat dyes contain the characteristic $>C=O$ group (keto group). In an alkaline sodium dithionite vat, the addition of hydrogen (= reduction, hydrogenation) takes place first of all to form the $>C-OH$ group which corresponds to the leuco form as the vat acid.

Vat Dye: A classification of dyes that are converted from a water-insoluble pigment form to a soluble leuco form (using a reducing agent), applied by immersion to fabric, then converted back to the insoluble form (by oxidation). The name comes from “vatting” which once meant using natural fermentation processes in a vat to produce the reducing conditions to make the dye soluble. Indigo, the blue of blue jeans, is a common vat dye. Vat dyes, with the notable exception of indigo, are generally very lightfast and washfast. Many have very good resistance to chlorine bleach. Multiple applications of dye may be required to build strong shades because of limited substantivity. Sulfur dyes use processes similar to vat dyes, but are distinguished by their sulfur content. Some modern vat dyes are supplied in already-reduced soluble form. Occasionally art dyes will say something is vat dyed when they mean it has been dyed with any dye type in a large volume of solution, as opposed to by direct application of dye or other techniques. This use should be avoided.

Vat Dyeing, Oxidation Of: An important stage in the development of correct shades in vat dyeing. After dyeing, the leuco vat dye which is present in its water soluble reduced form (enol form) must be reconverted into its insoluble keto form again. In exceptional cases this can be achieved by aerial oxidation (e.g. by hanging in air); as a rule, however, the oxidation stage is carried out in baths containing suitable oxidizing agents. The rate of oxidation is dependent above all on the constitution of the dye as well as on the type and concentration of oxidizing agent used and the temperature and pH of the oxidation bath. The most favourable pH for oxidation is from 10–11. The concentration of

oxidizing agent and the conditions of oxidation (temperature and time) should be kept to the minimum required in order to prevent damage to the fibre.

Vat Printing: The reduction process necessary for the fixation of vat dyes on the fibre can be carried out in two ways: (a) Potash process (“all-in” process): in this case the print paste contains both a reducing agent (e.g. sodium formaldehyde sulphonylate) and an alkali (potassium carbonate = potash). The thickeners normally used are starch-ethers, locust bean gums, alginates, etc. After printing during steaming, the shade of a vat dye changes to its so-called vatted colour, e.g. a blue may change to yellow or a green to red (usually the complementary colour is formed). After steaming, the printed fabric is finally oxidized and soaped. (b) Two-phase process: this method is only possible for prints on white (i.e. undyed) fabric and offers optimum process reliability. The water-insoluble vat dyes are printed first as pigments. Thickeners capable of undergoing coagulation are used to prepare the print pastes, e.g. locust bean gums and their modifications. Prints are finally developed by impregnation in a bath containing reducing agent/sodium carbonate or sodium dithionite/caustic soda followed immediately by steaming. This bath also contains sodium tetraborate which coagulates the thickener and prevents the vat pigments from bleeding out of the thickener film, thus ensuring sharp printed outlines. Excess liquor is squeezed off through a nip and the printed goods are steamed immediately to reduce the vat dyes to their soluble leuco compounds, in which form they can penetrate the fibre. Finally, the printed goods are oxidized, soaped and washed off as in (a) above.

Vat Yellow Paper: See **Indanthren yellow paper**.

Vatting: The process of converting Vat dyes from the water-insoluble (pigment) into the water-soluble substantive form (Leuco compounds) by reduction, usually with sodium dithionite and caustic soda.

Vatting test: An unreliable test for hydro-, oxy and photocelluloses. Cellulose which has been chemically damaged has reducing properties which are sufficient to convert Indanthren Yellow G (flavanthrene) in alkaline dispersion into its blue leuco compound. Procedure: treat the sample in an alkaline bath with the dye. Formation of a blue colour indicates chemical damage.

V-belts: (Vee belts) Transmission belts, drive belts with a tapered cross-section which run in the corresponding vee-tapered grooves of pulleys. V-belts are usually made of a rubber composition reinforced with V-belt cord. To transfer higher forces, several identical V-belts are used parallel to one another. Advantages: minimum possible distance between shafts, less wear, non-slip characteristics.

VCRS: Abbreviation for the Swiss Federation of Dry Cleaners (Verband Chemischer Reinigungsanstalten der Schweiz).

VDF: Abbreviation for the Society of German Dyers (Verein Deutscher Färber).

Vector dye media for multicolour printing: The usual colour solids conceived as colour ellipsoids can also be represented more simply as colour polyhedrons resp. as polyhedral colour lattices with defined colour edges and corners as colour vectors, e.g. in the form of four, five, six and seven vector colour solids. The seven vector colour solid has, e.g., 448 different coloured edges and 128 coloured corners. It is used for calculating mixing ratios of the yellow, magenta and cyan primary colours employed in typography.

vee notch weir: (1) A vee-shaped notch in a thin plate for measuring the flow of a water. For a 90° notch, the flow, Q in m³/s, is calculated by $Q = 1.42H^{2.5}$, where H is the measured head (in m) at the weir. (2) A type of *weir plate*.

VEGAT: Abbrev. for the Federation of Swiss Yarn and Tricot Finishers (Verband Schweizerischer Garnu. Tricotveredler).

Vegetable Dyes: Natural dyes

Vegetable Dyes, Sources: Yellow: Following plants dye Yellow. **Agrimony.** '*Agrimonia Eupatoria*'. **Ash.** '*Fraxinus excelsior*'. Fresh inner bark. **Barberry.** '*Berberis vulgaris*'. Stem and root. Birch. Leaves. **Bog Asphodel.** '*Nartheceium ossifragum*'. **Bog Myrtle or Sweet Gale.** '*Myrica Gale*'. **Bracken.** '*Pteris aquilina*'. Roots. Also young tops. **Bramble.** '*Rubus fruticosus*'.

Broom. *Sarothammus Scoparius*. **Buckthorn.** *Rhamnus frangula* and *R. cathartica*. Berries and Bark. Common dock. '*Rumex obtusifolius*'. Root.

Crab Apple. '*Pyrus Malus*'. Fresh inner bark.

Dyer's Greenwood. '*Genista tinctoria*'. Young shoots and leaves. **Gorse.** '*Ulex Europæus*'. Bark, flowers and young shoots.

Vegetable Dyes, Black: Following plants dye Black. Alder. '*Alnus glutinosa*'. Bark, with copperas. Blackberry. '*Rubus fruticosus*'. Young shoots, with salts of iron. Dock. '*Rumex*'. Root.

Elder. Bark, with copperas.

Vegetable Dyes, Blue: Following plants dye blue: Devil's Bit. '*Scabiosa succisa*'. Leaves prepared like woad. Dog's Mercury. '*Mercurialis perennis*'. Elder. '*Sambucus nigra*'. Berries.

Privet. '*Ligustrum vulgare*'. Berries with alum and salt. Red bearberry. '*Arctostaphylos Uva-Ursi*'. Sloe. [A] '*Prunus communis*'. Fruit. Whortleberry

or Blaeberry. '*Vaccinium Myrtillus*'. Berries. Woad. *Isatis tinctoria*. Yellow Iris. *Iris Pseudacorus*. Roots.

Vegetable Dyes, Brown: The following plants dye Brown: Alder. *Alnus glutinosa*. Bark.

Birch. '*Betula alba*'. Bark. Onion. Skins. Larch. Pine needles, collected in Autumn.

Oak. '*Quercus Robur*'. Bark. Red currants, with alum. Walnut. Root and green husks of nut.

Water Lily. '*Nymphaea alba*'. Root. Whortleberry. '*Vaccinium Myrtillus*'. Young shoots, with nut galls. Dulse. (Seaweed.); Lichens.

Vegetable Dyes, Green: Following plants dye green: Elder. '*Sambucus nigra*'. Leaves with alum. Flowering reed. '*Phragmites communis*'. Flowering tops, with copperas. Larch. Bark, with alum. Lily of the valley. *Convallaria majalis*. Leaves. Nettle. *Urtica dioica* and *U. Urens*. Privet. '*Ligustrum vulgare*'. Berries and leaves, with alum.

Vegetable Dyes, Purple: The following plants dye purple: Byrony. '*Byronia dioica*'. Berries. Damson. Fruit, with alum. Dandelion. '*Taraxacum Dens-leonis*'. Roots.

Danewort. '*Sambucus Ebulus*'. Berries. Deadly nightshade. '*Atropa Belladonna*'.

Elder. '*Sambucus nigra*'. Berries, with alum, a violet; with alum and salt, a lilac colour.

Sundew. '*Drosera*'. Whortleberry or blackberry. '*Vaccinium myrtillus*'. It contains a blue or purple dye which will dye wool and silk without mordant.

Vegetable Fibre: Natural cellulosic fibres; Cellulosic fibres, regenerated; Natural fibres; Fibres.

Vegetable Flannel: A coarse, hygienic cloth, made from the fibres of the pine needles.

Vegetable Gums: (natural gums). Carbohydrate high polymers insoluble in alcohol and other organic solvents which are obtained as dried exudations from various African and Asian trees and shrubs mainly of the acacia type in tropical areas. They are amorphous substances with very complex polysaccharide constitutions and are generally soluble or dispersible in water to give solutions with adhesive characteristics.

Vegetable Hair Fibre: Single cell seed hairs (Cotton; Akund) or fruit wall fibres (Kapok) of various plants the original purpose of which is to disseminate or protect the seeds. Natural cellulosic fibres; See **Fibres**.

Vegetable matter, in wool top: The pieces of burre, seeds, shive, leaves, twigs, grasses etc. which have escaped removal in processing, also foreign vegetable fibres such as hemp, sisal, etc., if present.

Vegetable matter base, in raw wool: Oven-dried scoured burrs, seeds, twigs, leaves, grasses etc., free of mineral matter and alcohol-extractable matter in raw wool.

Vegetable matter present, in raw wool: The weight of vegetable matter base present in the raw wool, adjusted to a moisture content of 12%, an alcohol extractives content of 1.5%, and a mineral matter content of 0.5%.

Vegetable Silk: See **Akund**.

Vegetable tanning: A considerable number of plants and bark woods offer technically economic yields of tanning agents on extraction. Most of these vegetable tanning agents are extracts from horse chestnut trees, wattle, quebracho bark, oak woods, mimosa bark, oak barks, valonia acorns, myrobalan fruits and other plants rich in tanning agents. These vegetable tanning agents are complex compounds of high molecular weight with numerous phenolic hydroxyl groups.

Veiling: An open ended fabric, usually net, made from silk, acetate, viscose, nylon. It is made plain or possibly with flocked spots for millinery, and often embroidered with elaborate patterns for bridal veils.

Vein: The open place in a cloth, caused by a broken warp.

Veining: Long incompletely drawn nodules in spun filaments, e.g. in finished polyamide fabrics caused by soiled polyamide starting materials in spinning. These nodules dye much darker than normal filaments.

Vel line: French woollen winter coating; has a curl pile surface.

Velour: The French for velvet. This is a fabric with short warp pile. There are many types of Synthetic Velour now available for a variety of uses, but originally velour was a thick woven overcoating made from top quality wool with a soft close nap on the right side. A napped surface woven fabric or felt in which the surface fibres are laid in one direction to present a smooth appearance. Generally used as coating material, but in lighter weights and with check patterns, it is also used for dress goods. Usually it is of 10-20 oz. per yard. Various types of yarns are used to make several types of velour. Some velours are made with synthetic and wool blends. There are also many fabrics similar to velour but with a slightly different finish. These are sold under different names as suedyne, suedette, lustora, duvedelaine and valora. An expensive fabric used for men's and women's coats.

Velour, Warp: See **Velour**. A French word derived from the Latin *vellosus* = “hairy”. *Velour* is a general term for Warp velvet (Velvet). The pile is formed by an additional warp thread system, i.e. two warp thread systems are used, the ground warp and the pile warp, and one weft thread system. *Velour* is produced as wire and double velvet. Wire velvet can be produced as cut velvet (*velour-coupé*) with cutting wires, as curled velvet with an uncut pile (*velour-frisé*) as well as mixed velvet (with alternating cut and uncut pile). Patterned warp velvets are also produced. Numerous modifications exist, e.g. with transverse stripes (*velour-chiffon*), transparent (*velour-transparent*), so-called mirror velvet (*velour-moiré*), or additionally patterned with a swivel embroidery stay.

Velours: French for velvet.

Velours a Deux Pells: French term for velvet with a pile made of two-ply yarn.

Velours a la Reine: Crossribbed silk fabric, made with one set of wrap and two sets of fillings, the ribs alternating with two picks of the liner filling.

Velours Biseautes: Velvet galloon with higher pile on one edge than on the other.

Velours Bombes: French silk velvet, consisting of alternate stripes of cut and uncut velvet.

Velours Broche: Brocaded velvet.

Velours Cameleon: Changeable velvet, made with two sets of pile warps, each of a different colour.

Velours Chine: Silk velvet, the pile -warp of wh.ch is printed with pictures, etc., before weaving.

Velours Cisele: French for velvet upon velvet; originally -made with two different rods, now the uniform deep pile velvet is subjected to heavy pressure, laying down the pile in certain parts of the fabric. The standing pile is shorn short and the pressed-down pile is steamed and brushed up.

Velours Couche: A velvet woven with a straight silk pile, which in the finishing process is crushed or laid down; used for coats, trimmings and drapery.

Velours d'Angleterre: Silk weft pile velvet.

Velours d'Italie: Crossribbed fabric made of silk and cotton, the ribs alternating with two fine fillings.

Velours d'Oran: A warp pile French velvet, both sets of warp containing ends ranging from single yarns to five-ply yarns, arranged in natural and reversed

order several times the entire width of the fabric. The two sets of warps are placed in such a manner that the five-ply yarn in one set corresponds to the single yarn in the other, and vice versa.

Velours de Gueux: Velvet made of a single set of linen or heavy cotton warp and fine cotton filling, forming the pile.

Velours de Hollande: Cut velvet originally made of all silk, with good organzine warp and filling.

Velours de Genes: Usually all-silk velvet, the warp, filling and pile made of organzine.

Velours du Nord: Silk velvet having a longer pile than velvet but shorter than plush.

Velours Ecrase: Silk velvet having highly finished, crushed pile, lying in different directions.

Velours Epingle: Lightweight, solid coloured French silk velvet.

Velours Figure: Figured velvet.

Velours Francais: Obsolete French velvet, made with two sets of silk warp of different colours, one being single yarn and the other three-ply yarn. There are also two sets of different coloured boiled off silk filling.

Velours Frappe: Velvet having raised patterns produced by pressing the pile with heated cylinders.

Velours Frise Uni: Lightweight French silk velvet with single, double or triple pile; used for dresses, millinery, etc. comes in solid colours.

Velours Gandin: Silk velvet over satin foundation; used for drapery, etc.

Velours Glace: A velvet having the pile slightly dressed -with size and pressed down in different directions, producing a frosted effect.

Velours Gregoire: French velvet of the first part of the 19th century, showing pictures woven in pile.

Velours Miroii: Glossy silk velvet with a crushed pile.

Velours Ombre: Warp pile velvets, usually ribbons, made in ombré effects.

Velours Ottoman: French silk fabrics made with two sets of warp, one forming the foundation in plain weave, the other forming floats, half of the warp floating on the face, the other half on the back.

Velours Ras: French for uncut velvet.

Velours Rayes: Striped velvet.

Velours Russe: Velvet dress fabric made -with varicolored diagonal cords.

Velours Sculpte: Velvet having patterns formed with the pile shorn different lengths; see velours cisele.

Velours Simule: Obsolete term for a plain woven fabric made with silk warp and cotton filling. Both the warp and the weft contain threads of various thickness.

Velours Travers: Half wool dress goods velvet with weft stripes.

Veloutine: (1) French dress fabric, made with thick woollen warp, forming cords and soft merino filling; finished with a nap. (2) A lightweight weft-pile fabric with a pronounced twill effect mainly used for linings. (3) A fine cord fabric produced from a silk warp and a wool weft.

Velure: Same as velours.

Velutine: A short pile velveteen, the back sized in the finished.

Velveret: Usually wide cotton velvets made to imitate silk, often having ribs or finished with printed designs. The filling usually crosses two warps at once. Made in England, United States, etc.

Velvet: Velvet, once only silk, may now be cotton, nylon. Acetate, viscose, polyester, modal etc. Velvet is identified as cloth with a pile of no more than 3 mm. length. The fabric is woven with a warp pile and additional yarn. In production wires are inserted to lift this yarn and the when withdrawn, there are loops which are cut or not according to the type of velvet being made. The anchored pile loops can have a V-shaped or a W-shaped form. In the nature of things, the W-form is more firmly anchored. A distinction is also made between warp velvet (Velours) and weft velvet. Velvet is one fabric that dyes truly; There are no bad colours in velvet fabrics, all are rich and attractive. Used for all types of special dresses for men, women, children and there are also special furnishing velvets. An average velvet construction is 150 x 100 with 50 denier bright rayon ground and pile and 75 denier bright rayon filling. It weighs around 4.5 oz. per sq. yard. Some of the varieties of velvet are (a) Bagheera is a fine uncut pile, velvet with a rough surface that makes it crush resist (b) chiffon velvet is a soft light weight velvet with the pile pressed flat (c) Cisele is made by a contrast in cut and uncut loops. (d) Lyons is a stiff thick pile velvet which is used for hats and dresses, suits and evening clothes. (e) Nacre velvet: is one in which back is usually of one colour and the pile another. (f) Transparent or sheer velvet: is lightweight soft velvet with thin silk or rayon back and a heavier rayon pile. For instance 60 denier rayon can be used for ground warp and weft and 150 denier rayon for the pile warp.

Velvet Carpet: A woven carpet in which the pile ends are lifted over wires that are inserted in the same manner as the filling and that cut the pile as they are withdrawn.

Velvet Fabric: A warp-pile woven fabric with short, dense cut pile that produces a rich fabric appearance and soft texture. Two methods are used for weaving velvets. In the double-cloth method, two fabrics are woven face to face with the pile ends interlocking. A reciprocating knife cuts through these pile ends to produce two separate pieces of velvet. In the second method, pile ends are lifted over cutting wires that are inserted with the filling and that are withdrawn to cut the pile. Velvet is produced in a wide range of constructions and types. Originally made of silk, but now also of cotton or manufactured fibres giving fabrics that are sometimes washable. The fabric can be specially finished to make it crush-resistant and water-repellent or it may be embossed or patterned by burn-out printing.

Velvet Finish: Consists in heavily napping woollen fabrics; the nap is shorn or left as it is.

Velvet Pile Carpets: A collective term for carpets produced by various methods of manufacture with a cut plush-like pile. Cut-pile carpets. (a) A cut-pile carpet made in the same manner as tapestry carpets, but substituting cutting wires for looping wires. (b) A non-jacquard carpet with the same construction as a Wilton carpet.

Velvet Rug: Carpets and rugs woven on the same principle as warp pile velvets.

Velvet Satin: A silk fabric made with patterns in pile over a satin foundation.

Velvet Stitch: See **Raised stitch**.

Velvet, cisele: A velvet with a pattern formed by contrast in cut and uncut loops. Faconne Velvet Patterned velvet made by burnt-out print process. The design is of velvet with background plain. Lyons Velvet A stiff, thick pile velvet. Used for hats, coat collars, also for suits, coats and dresses, when thick velvets are fashionable.

Velvet, nacre: The back is of one colour and the pile of another, so that it gives a changeable, pearly appearance. Transparent Velvet (Chiffon Velvet) Lightweight, very soft, draping velvet made with a silk or rayon back and a rayon pile. Panne Velvet Has a longer or higher pile than velvet, but shorter than plush. It is pressed flat and has a high lustre made possible by a tremendous roller-press treatment given the material in finishing. Now often made as knit fabric.

Velveteen: A fabric in twill or plain weave made with a short closely packed weft pile in imitation of velvet. The fabric usually cotton, that is made in the same way as Courduroy, but the surface is completely covered by the short-cut pile. It may be plain or printed and it varies in weight. The colours are good and and it is equally as attractive as velvet. Its great advantage is that it is not difficult to sew.

Velveton: Medium to heavy cotton sateen with an emerised or raised and cropped suede surface, like Duvetine and Moleskin. Firm, durable and washable. Used for trousers, jackets, trimmings and furniture covers.

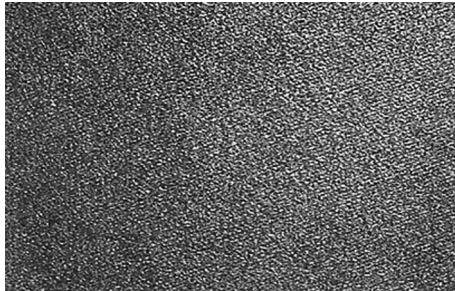

Venetian: A cloth milled and cropped bare in finish.

Venetian: A well-known fabric term used to describe a highly lustrous twill cloth originally made in Venice from silk. When made in satin weave from wool, it is the cloth worn by Arabs visiting Mecca. Venetian for men's suiting is made from worsted yarn, but women's cloth can be made from synthetic varieties, usually polyester. Used for suits, skirts, trousers- expensive. See **Sateen, fine**.

Venetian Carpet: Originally made with various coloured worsted warp and some cheap filling which was hidden, the pattern being on both sides in warp stripes; of English origin.

Venetian Crepe: It is made with raw silk warp and very coarse tilling, two right hand twist and two left hand twist alternately; used for mourning.

Venetian Embroidery: On batiste foundation, the patterns are outlined with 'buttonhole stitches, the ground is cut away and the parts connected with bars.

Venetian Lace: Floral motifs and designs connected with picots and brides. The effect is irregular. Originally a Needle point Lace.

Venetienne: (1) French dress goods made of fine Italian (yellow) silk with ribbed weave like gros de Tours, and printed or left in one colour; (2) French woollen dress goods, finished with slight fulling.

Venise: Very fine damask table linen made in Holland and France; the pattern consists of large flowers.

Venturi: A particular type of jet in the form of a tube which is narrower in the centre and wider at the ends. This shape produces a higher rate of fluid flow in the central region.

Verandol: In Cuba a pure linen or cotton mixed cloth, white or beige. The white is used as dress goods, the beige as bed cover.

Verdigris: Green basic copper (II) carbonate formed on the surface of copper exposed to moist air (patina).

Verification: The act or process of verifying.

Verify: (1) To determine whether a previously calibrated instrument, standard solution, or other standard is still properly calibrated.

(2) To establish that an operation has been completed correctly.

Vermont: Australian term for wool yielded in Australia by sheep which descended from the merinos.

Verona Serge: Lightweight serge, made of mohair and cotton or worsted and cotton in mixture effect.

Vertical Drier: A sieve-drum drier of vertical design based on the through-flow principle which offers the highest heat transmission coefficient and maximum drying performance in the smallest space. Heat recovery is determined by the machine construction. The specific heat losses in this type of drier are low due to its compact design and effective heat insulation (without thermal bridges).

Vertical Flame Test: See **Flammability test**.

Vertical Flammability Test: See **Flammability test**.

Vertical Migration: (selective migration). The variable rate of migration of a dye combination through the cross-section of a textile fabric. This behaviour is exploited intentionally for the production of Two-sided effects by vertical migration between the face and back sides of a textile material to give either a different colour on each side (two-colour effect) or different depths of the same shade (dark/light effect). See **Migration**.

Vertical Open Width Washing Machine: A machine with a series of open-width compartments for washing off or impregnating fabrics with chemical liquors (e.g. in pretreatment). See **Roller vat**.

Vertical organisation: Mills that take in fibre, spin yarns, dye these and then either weave or knit these into fabric/garments.

Vertical Padder: A Padder with a vertical arrangement of squeeze rolls. See **Padder**.

Vertical roller printing machine: A roller printing machine formerly produced by Some manufacturers with a vertical arrangement and an individual pressure roll for each engraved printing roller or rotary screen. The colour boxes, doctor blades and furnisher rollers are all mounted on a hinged sub-frame which can be swung to one side (like a gate) thereby offering the advantage of easier and quicker servicing compared to conventional roller printing machines.

Vertical space-dyeing printing unit: A development for Space-dyeing (Micro-Space) with vertical fabric transport from bottom to top and up to 6 pairs of printing rollers (print stations) as modular units. Splashing of print pastes at high speeds is prevented with this system and the practical application of lint doctors is possible.

Vertical star dyeing machine: An upright star dyeing machine where vertical movement of the loaded star frame in the dye liquor is actuated by a cam.

Vertical Suedeing Machine: (sanding, emerizing). A surface finishing machine for the Sanding and Emerizing of knitted and woven fabrics. The fabric runs tangentially against the sanding resp. emerizing rollers.

Vervise: A woollen fabric, made in England under Edward VI, believed to have been of blue or gray colour.

Vetterman Drum Test, in carpet: Instrument used to test appearance retention.

VI: (1) Viscose fibres, (2) Abbreviation for Viscosity index.

Vi: Vicuna.

Vibraire process: A continuous felting process for yarns and slivers co-developed by the Fibre Research Institute TNO Delft and the IWS England. The yarn is passed, together with the felting liquor, through a tube which is subjected to intense vibrations (also known as the Periloc process).

Vibroscope: An instrument for determining the mass per unit length of a fibre.

Vicara: See **Cashmere**.

Vichy: (1) Gingham in Chile, Bolivia and Spain, often in large checks and plaids, and stiffly -finished; (2) Fine gingham in Servia; (3) General term in Turkey for cheap gingham and yarn dyed cotton plaids, usually having a stiff, starchy finish. (4) A cotton dress fabric generally made with two different coloured yarns.

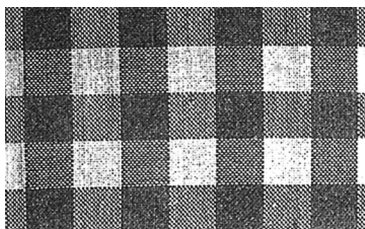

Victoria: Sometimes called Victoria Lawn, this is a stiffened cotton 90 cm. (36in.) wide and used as an interfacing.

Victoria Crepe: English, all-cotton crepe of lustrous finish.

Victoria Lawn: Plain and very closely woven heavy English lawn, about 38 inches wide, having as high as 100 by 175 ends in a square inch. Comes white or printed. Used for dresses, the lighter weights for underwear.

Victoria Shawl: French shawl, made on the Jacquard loom with four embroidered borders and warp fringes at both ends; obsolete.

Vicuna: (1) Very long, soft brownish hair yielded by the South American vicuna goat related to the llama and the guanaco (Peru and Bolivia). Only the undercoat hair is processed— deep yellow to reddish brown, soft, silky-glossy, curly and fine (10–20 mm, around 84 scales/mm).; (2) Trade name for yarn composed of coarse wool and cotton or all-cotton finished in imitation of woollen yarn; (3) A soft twilled cloth similar to cheviot, finished with a soft nap, made of the Andes vicuna, an animal threatened with extinction, hence its name. The hair is soft and pale brown and makes the most expensive and luxurious cloth there is. (4) Imitation of the above, made of soft wool, often mixed with cotton, slightly fullered and napped; used for men's suits and overcoats. See also **Vigogne yarn**.

Vienna Cross: Same as Persian cross stitch.

Viewing Booth: A enclosed area with controlled lighting that is used in graphic arts studios, textile manufacturing, service bureaus, and printing companies as a stable environment for evaluating proofs and press sheets. Viewing booths are generally illuminated using graphic arts industry-standard D65 lighting, and are surfaced in neutral gray colours.

Vigogne: French for Vicuna.

Vigogne Yarn: (1) Originally made of a mixture of cotton and wool, of varying proportions (in Europe 20 per cent cotton, 80 per cent wool), used for cheap hosiery, etc.; (2) In Germany, Russia and Italy yarn made of all cotton and cotton waste, finished to look like wool.

Vigoureux Printing: (tops printing). Diagonal or transverse striped printing of combed wool tops (using relief rollers). The twisted and drawn essentially homogenous blends produce mixtures of different coloured fibre. In most cases, black is used for printing which gives grey colour-blend effects depending on the depth of colour in the mixture and cover in non-printed areas. Zebra-striped patterns are produced which blur after drawing and spinning.

Vigoureux yarn: Mottled yarn which is made by printing stripes in a single colour on combed top in Vigoureux printing and then doubled and stretched several times.

Viloft: A versatile viscose fibre, hollow when seen in the cross section, produced by Courtaulds. It is soft, warm, absorbent, and dyes well. Used in blends with polyester, and fabrics often resemble cotton. Made into knitted and woven fabrics and also pile and loop fabrics. Used for sportswear, underwear, toweling, ribbed toweling, and terry toweling.

Vimoutiers: Coarse and loosely woven French unbleached linen, sometimes dyed yellow.

Vinal Fibre: American generic name for polyvinyl alcohol Fibres. A manufactured fibre in which the fibre-forming substance is any long chain synthetic polymer composed of at least 50% by weight of vinyl alcohol units and in which the total of the vinyl alcohol units and any one or more of the various acetal units is at least 85% by weight of the fibre (FTC definition). Vinal fibres show good chemical resistance but soften at comparatively low temperatures. Vinal fibres are used for apparel, industrial goods, and fishnets.

Vinal-Vinyon: Vinal fibres are made from polymers containing at least 50% vinyl alcohol units and in which at least 85% of the units are combined vinyl alcohol and acetal crosslink units. The fibre is inexpensive, resembles cotton in properties, and is produced in Japan. A very soft fibre which is similar to acrylic. It has excellent flame retardency. Used mainly for children's nightwear.

Vincel: Branded cellulosic fibre. It closely resembles cotton, but is slightly weaker. Vincel (modal) is soft and absorbent and on its own is made into fabrics for nightwear, but can be blended with other fibres such as cotton, for additional body.

Vinegar: Dilute acetic acid, typically around 5% Vinegar is a convenient acid for many dyeing processes, although a lot may be required because it is so dilute. Much of the white vinegar sold is made by diluting concentrated acetic acid produced by synthesis from natural gas. Vinegar diluted with 10 parts of water will give a pH of around 4.2.

Vinyl group: The group $\text{CH}_2\text{:CH-}$.

Vinyl: Short form for Polyvinyl chloride (PVC).

Vinyl: A univalent radical, $(\text{CH}_2=\text{CH-})$, derived from ethylene.

Vinyl Sulphone Dyes: As a Sulphatoethylsulphone dye, the commercial form contains a protected reactive group. In this ester form, they only have moderate substantivity. A type of reactive dyes, generally used for cellulosic fibres but with some use for wool. Vinyl sulphone reactive dyes are intermediate in reactivity, so they are applied above room temperature, but well below the boiling point of water. The actual reactive dye, vinyl sulphone, is not released until the required alkali is added for dyeing to take place so they can be stored as solutions for much longer periods than highly reactive dyes. In this form, the dye is now reactive showing high substantivity. Wash fastness may be somewhat inferior to some other reactive dyes. Vinyl sulfone dyes can be a good choice for dyeing the background colour for discharge, since they are quite easy to discharge with reducing agents. There are also simple chemical resists, that work well with these dyes, preventing fixation to the fibre, so they find application in printing processes. Remazol is a popular brand name.

Vinyl Sulphone: See **Vinyl sulphone dyes**.

Vinyl Sulphone Group: $-\text{SO}_2-\text{CH}=\text{CH}_2$. Reactive group which reacts with the OH groups of cellulose: $-\text{SO}_2-\text{CH}_2-\text{CH}_2-\text{O}-\text{Cell}$ in the presence of alkali. See **Vinyl sulphone dyes**.

Vinylal: Generic name for fibres based on Polyvinyl acetate, i.e. acetylated, making the polyvinyl alcohol fibres insoluble in water.

Vinylidene Chloride: A chemical material obtained from ethylene, a petroleum product, and from chlorine. It is used for the manufacture of textile monofilaments and film. It is more commonly identified in the U.S. as Saran. (Also see **Saran fibre**).

Vinylidene fibre: Polyvinylidene chloride fibres.

Vinylon: Since 1948, generic name for polyvinyl alcohol fibres made in Japan.

Vinyon: Generic name for a fibre made from vinyl chloride. Vinyon is defined as a fibre in which at least 85% of the polymerized monomer units are vinyl chloride. Vinyon fibres have high chemical and water resistance, do not burn, but do melt at relatively low temperatures and dissolve readily in many organic solvents, thereby limiting their application. It is resistant to chemicals, softens at low temperature. More commonly referred to as Polyvinyl chloride (PVC).

Vinyon Fibre: A manufactured fibre in which the fibre-forming substance is any long chain synthetic polymer composed of at least 85% by weight of vinyl chloride units.

Violanthrone: See **Dibenzanthrone**.

Virgin Wool: Wool which has never been reclaimed from any spun. Woven, knitted, felted, braided, bonded, or otherwise manufactured or used product.

Virginia: (1) French silk fabric, made in an eight-leaf twill weave; (2) Six or eight-leaf figured serge made with single or ply warp.

Visible matter in cotton testing: Foreign matter deposited in the waste boxes of the machine during the test.

Visible Radiation: Visible light is a narrow band of electromagnetic radiation from 400 to 700 nm (1 nm equals 10^{-9} meters) detected by the human eye. Radiation falling below 400 nm is ultraviolet radiation, and that falling above 700 nm is infrared radiation; both are unseen by the human eye.

Visible Spectrum: The region of the electromagnetic spectrum between 380 and 720 nanometers. Wavelengths inside this span create the sensation of colour when they are viewed by the human eye. The shorter wavelengths create the sensation of violets, purples, and blues; the longer wavelengths create the sensation of oranges and reds.

Viscoelasticity: Property of a substance which, when subjected to shear, compressive and tensile stresses, shows both viscous and elastic properties (Viscosity, Rheology). Plays a decisive role in textile printing. As the polymer molecules are subjected to increased stress, the viscosity of the swollen thickener spontaneously drops and increases again as the stresses are relaxed.

Viscometer: A device designed to measure the viscosity (resistance to flow) of the fluid. Many types exist from simple calibrated glass tubes to extensively instrumented, on-line shear viscometers. (a) Capillary viscometer. (b) Flow cup (c) Falling-ball viscometer (d) Rotary viscometer (e) Vibration viscometer (f) Compression or extension viscometer.

Viscometer, torsion type: (visco printogram). Used to determine the Viscosity of printing thickeners; See **Viscosity of printing pastes**.

Viscose: (1) Hollow fibre usually made from wood pulp. The fibre is soft and absorbent and can be used alone and mixed with other fibres to produce fabrics of all types and weights. Due to its versatility viscose is one of the most commonly used synthetic fibres. (2) Spinning paste, thick, viscous, made from alkali cellulose and carbon disulphide dissolved in caustic soda solution. Starting material for See **Viscose fibres**.

Viscose fibre: The generic name for fibres formed by the regeneration of cellulose from viscose (q.v.) by treatment with a solution of electrolytes (salts and acids). (See also **spinning bath**).

Viscose Embossed Satin: A firm patterned satin for bridal wear but it does not drape well, so designs should be structured; avoid gathers.

Viscose high tenacity fibres: (rayon cord, supercord, all-skin fibres and modal fibres), developed with the aim of increasing strength, dry modulus, fatigue resistance and dimensional stability, etc. This aim was realized to a limited extent using older spinning methods (such as the Lilienfeld and Lanusa principle and stretch spinning similar to cupro). By modifying viscose (Modified fibres) the production of high strength viscose fibres with thickened Covering layer and super-strong viscose fibres in all-skin structure with high-strength and high elongation. Use: as a filament for industrial fabrics, tyre cord, fabric linings, conveyor belts and drive belts. As a staple fibre: alone or in a mixture for rainwear, uniform fabrics, work clothing and protective clothing.

Viscose Modified Fibres: See **Modified Fibres**.

Viscose Process: (1) One of the methods of producing rayon. (Also see **Rayon fibre**).

(2) The chemical process used in the manufacture of cellophane. (Also see **Viscose solution**).

Viscose Rayon: One type of rayon. It is produced in far greater quantity than cuprammonium rayon, the other commercial type. (Also see **Rayon fibre**.)

Viscose Solution: The solution obtained by dissolving cellulose xanthate in caustic soda, from which viscose filaments and cellophane are produced.

Viscosity (Lat.: viscum): (1) Thickness, internal friction, internal resistance of a fluid against the relative movement of two neighbouring layers, i.e. the resistance a substance offers to flow. (2) Cellulose: A term applied specifically to signify the viscosity (see (1) above) of a standard solution of cellulose in cuprammonium hydroxide solution of specified copper and ammonia content. The flow behaviour of a mixing is best described by a flow curve relating apparent viscosity (in mPa.s) to shearing stress (in Pa). If the shearing stresses operative in the sizing were known, the apparent viscosities of the mixings at these stresses would be related to their sizing behaviour. Without this knowledge, measurements at some arbitrary stress (say 100 Pa) have to be used. These are of value in characterising a particular type of size and can often be related to the take-up of size by the warp.

Viscosity of Print Pastes: The rheological behaviour of print pastes plays a part in textile printing which is not insignificant. Apart from tensile loads, shear forces in particular act on the pastes (Rheology in printing and coating). However, viscosity measurement has been introduced into printing practice

indirectly as thickener manufacturers use the flow properties to characterize thickeners and then use this information in formulation recommendations.

Visible radiation: Any radiant energy capable of causing a visual sensation.

NOTE: The limits of the spectral range of visible radiation are not well defined and may vary according to the user. The lower limit is generally taken between 380 and 400 nm and the upper limit between 760 and 780 nm (1 nanometer, 1 nm = 10.9 m).

Visible Region of the Spectrum: See **Visible radiation**.

Visible waste in cotton testing: Foreign matter deposited in the waste boxes of the achine during testing.

Viyella: A trade name describing an old-established, classic fabric. However at times the name Viyells is generically used. The fabric still has the same composition as the original, i.e. 55 per cent lamb's wool and 45 per cent cotton, and it is a fine, soft twill weave material. It was first produced in 1983 in Britain and for a long time was used almost exclusively for children's clothes, babywear and nightwear. Later, it became a popular fabric for blouses and shirts. Now, mostly due to improved designs, it is used for top fashion clothes.

Viyella Pure Wool: This fabric, as well as Viyella Challis and Viyella Pure cotton, has been introduced recently by the manufacturers, William Hollins. Used for skirts and blouses, it is produced in a range of checks, floral and Persian designs, also co-ordinated plain and prints.

Vocational career apparel: Career apparel which is generally subject to abusive wear and for which durability is a more important attribute than appearance.

Voile: Voile is a high twist yarn, but the term Voile refers also to a fine, light, plain weave fabric made in a variety of yarns. A characteristic single voile is 60 × 56 with 50s warp and filling. A ply voile will be similar but will be with 2/100s yarn. Cotton, and also polyester with cotton, produce a soft comfortable fabric used for blouses, dresses, children's clothes and sometime for mens shirts. Voile is also made from silk.

Voile, full: A voile in which warp and weft are ply yarn, See **Voile**.

Voile, imitation: A voile in which warp and weft are simple yarn (Indian mull). See **Voile**.

Voile, semi: A voile in which warp is ply yarn and weft is simple yarn.

Voile, silk: A fine silk voile in which warp and weft natural silk.

Voilette: French machine-made lace, having a very fine mesh ground. Along the edge it is embroidered with light flower design while the body is trimmed 'with dotted powdering or fine trailing lines.

Voile Fabric: A sheer spun cloth that is lightweight and soft. It is usually made with cylindrical, combed yarn. Voile is used for blouses, children's wear, draperies, bedspreads, etc.

Voile Yarn: Fine, hard-twist (gas-singed) cotton or worsted ply yarn.

Volatile: Readily vaporized at a relatively low temperature.

Volatiles: Materials readily vapourisable at relative low temperatures.

Volatility: Property of having a low boiling point or temperature of sublimation at normal pressure. Likewise, having a high vapor pressure at ambient conditions.

Volume ratio: Millilitres/litre (ml/l).

Volume Resistivity: The ration of the potential gradient parallel to the direction of current flow in a compound to the current density after a specified time of voltage application.

Vraio Reseau: In real laces the net ground which was made either by the needle or with the bobbins.

V-Shaped Creel: V-shaped creel: in this creel type, the creel boards are assembled in form of endless chains. While warping is carried out from the outer sides using the already creeled up bobbins, the subsequent yarn lot can be creeled up on the empty spindles positioned inside the creel. This interior room serves at the same time as storage and bobbin exchange station.

The yarn lot can be changed by simply pushing a button, which starts the electrically drive of the chains. The empty bobbins move towards the inside of the creel, the full bobbins towards the outside.

VSM: (1) Swiss standards organization. (2) Swiss textile machine organization.

VST: Association of Swiss Textile Specialists (Vereinigung Schweizer Textilfachleute). United with VeT to form SVT.

VSTV: Association of the Swiss Textile Finishing Industry, Zurich (Verband Schweizerischer Textilveredlungsindustrie).

VTCC : Verein der Textilchemiker und Coloristen. Today VDTF.

Vulcanised Fibre: Cellulose-plastic (plasticized using zinc chloride solution; paper webs "welded" by roller pressure) in the form of slabs, rods and tubes. Horn-like, tough, hard to leather-like soft and pliable. Absorbs little water (also water-proof impregnated). Resistant to oils and hydrocarbons, etc.

Low flammability. Can be machined in any way to make gearwheels, sealing washers and suitcases (and the like).

Vulcanization: An irreversible process, usually accomplished through the application of heat, during which a rubber compound through a change in its chemical structure (for example cross linking) becomes less plastic and more resistant to swelling by organic liquids and elastic properties conferred, improved or extended over a greater range of temperature.

Vulcanization: A process of improving the quality of rubber (hardness and resistance to temperature changes) by heating it with sulfur (about 150°C). Accelerators are used to speed up the reaction. Certain sulfur compounds can also be used for vulcanization.

VY: Vinylal.

W

W: Abbreviation for Watt.

WA: Angora fibre.

W/O, Water-in-oil emulsions: (W/O emulsions). See **Emulsion; Emulsion thickener.**

W/V : Weight by volume.

W/W: Weight by weight.

Wadding: (1) Cotton wadding is thick and lightweight. It is sandwiched between two papery layers of non-fluffy, shiny covering which hold it together. The wadding can be split to half depth. Use for quilting, shoulder pads etc. Polyester wadding is more open and springy and firmer than cotton. It is available in various thicknesses, i.e. 2 oz. 4 oz. 8 oz. 8 oz. per metre. Use for shoulder pads, quilting, padding embroidery.

(2) Waste silk, obtained from the inner smooth skin of the cocoon, left over after the reeling.

Waffle pique; waffle honeycomb: Woven cotton fabric in which warp and weft threads form ridges and hollows giving a cellular appearance. Fine qualities for blouses and trimmings; heavier types of towels and bathrobes.

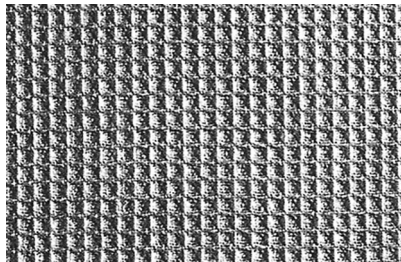

Waffle honey comb

Waist, in anatomy: The part of the body at location between the lowest rib and hip identified by bending the body to the side.

Waist girth, in body measurements: The circumference of the waist immediately below the lowest rib.

Waistband (one-piece): A single thickness of fabric that is doubled and stitched to the top of a pant.

Waistband (Two-piece): When two identical pieces of fabric are placed back-to-back at the top of a pant, raw edges turned inside, and joined with two widely spaced rows of titching. The pant body is inserted between and along one edge.

Wale, in knitted fabrics: A column of loops in successive courses that is parallel with the loop axes.

Wale, in woven fabrics: One of a series of raised portions or ribs lying warpwise in the fabrics.

Wale: A diagonal raised line formed by a twill weave on the face of the fabric, usually woollens and worsteds.

Wale count: The number of wales in a knit fabric per unit length. For example: wales per inch.

Wale density: Number of wales per centimetre of fabric width (wale density), this is the number of vertical columns composed of stitches per unit length of fabric through the fabric width (generally, 1 cm of fabric is taken).

Wall-To-Wall Carpeting: A term for carpets that are laid from wall to wall (fitted carpets). Contract carpet.

Walk test: (1) Method of testing wear resistance, such as soiling properties and pile firmness in textile floor coverings. The sample is spread out in an area where people frequently walk, usually together with a comparable carpet that has known properties. Soil pick-up, wear, colour change, etc. are monitored over several months. (2) Test to establish the electrostatic properties of textile floor coverings. (AATCC Test Method 134 – 1979): in this test a person walks backwards and forwards in a specified manner with specified soles and heels over a carpet which has been conditioned for at least 3 days in dry air (23°C and 25% relative humidity). The test person carries a sensor connected to a static voltmeter which registers the voltage absorbed by the body. The test is carried out with three standardized shoe soles: (a) BAM = natural rubber; (b) Neolite = synthetic rubber, and (c) polyvinyl chloride = a typical synthetic shoe sole material. If the voltage exceeds the sensitivity threshold, the carpet has not withstood the Walk Test. The sensitivity threshold is the voltage at which only few people are aware of any static shock or discomfort. In general, 2000–3000 V has been agreed upon and, for this test, the limit has been fixed at 2000 V.

Walking Coat: A compromise between a single breasted sack and a cutaway frock, more nearly resembling the latter, but shorter and with pocket flaps on hips.

Walking foot: Walking foot is a special foot that insures uniform material feed when sewing multiple layers of fabric. This is the best foot to use when quilting and sewing on your binding.

Wammus: A sort of Cardigan jacket.

Wand: A tool used to deliver cleaning solution to carpets and apply vacuum to remove the solution. A *wand* usually consists of an extension handle and a *cleaning head*. Various types are light weight wand, drag wood (heavy duty) and power wand which has a motorized rotating or vibrating part to aid soil release.

Warangal carpets/rugs: Carpets made in Warangal, Andhra Pradesh, India in 17th and 18th centuries or earlier. The Warangal Rugs were prized for two traits. Firstly, their exceedingly fine count of the stitches, about 12000 to the square foot and secondly, they were the only examples in which silk was ever used in carpets with a perfectly satisfactory effect. Birdwood describes a late 17th to an early 17th century Warangal Carpet that took almost 10 years to complete. "It is a marvel of weaving. There are 400 knots to every square inch of it, giving a total of 3.5 million for the entire surface, and so complicated is the pattern that a change of the needles was required for every knot." Cheap 'thug carpets' from the jail factories and the stratospheric price killed the Warangal Carpets.

Wardrobe: Clothing, in particular outerwear, dresses, general outer garments, in French it also applies to underwear.

Warm-dyeing vat dyes: Vat dyes that act in a heated environment on the basis of the IW dyeing method.

Warmth to Weight Ratio: A measurement used to evaluate the effectiveness of an insulated product in relation to weather conditions and the environment. The insulation with the best rating is down. Down provides the best warmth to weight ratio over almost any other insulation material, which is why you will see down garments and sleeping bags as the primary choice for use in almost every high altitude, cold weather expedition.

Warp: A yarn running lengthwise in a woven fabric.

Warp: A group of yarns in long lengths and approximately parallel, put on beams or warp reels for further textile processing including weaving, knitting twisting, dyeing etc.

Warp (n): (1) Threads lengthways in a fabric as woven. (2) A number of threads in long lengths and approximately parallel, which may be in various forms intended for weaving, knitting, doubling, sizing, dyeing or lace-making.

Warp (v): To arrange threads in long lengths parallel to one another preparatory to further processing. In addition to beaming, the following methods of warping are practiced: ball warping, cross-ball warping and chain warping. The primary stage of these methods of warping is the withdrawal of the ends from a warping creel and their assembly in rope form, a form that may conveniently be used for wet processing. For convenience of handling, this rope may be: (a) wound into a ball (ball warping); (b) machine-wound onto a wooden roller into a cross-ball cheese (cross-ball or cheese-ball warping); (c) shortened into a link chain (chain warping). A number of these ropes may be assembled into a complete warp on a beam in a dressing frame, or may be split and dressed and incorporated in warps made by other methods. (See also section warping.)

Warp bands: See **Sextion mark**.

Warp beam: A large spool or flanged cylinder around which the warp threads, or ends, are wound in a uniform and parallel arrangement. Also see **Beam**.

Warp beam centrifuge: Centrifuge for beam dyeing machines or card lap beams, usually upright rather than horizontal.

Warp bow: Deviation of the warp yarn from a straight line; alternatively, curvature of the warp yarns.

Warp control: See **Let-off**.

Warp drawing: Warp-drawn fibres may be taken up on packages other than beams.

Warp dyeing process: This process is used for the manufacture of warp patterned carpets. Pile yarns are wound in parallel onto drums with dye liquor application systems, they are dyed in stripes, and finally the dye is set using steam.

Warp elongation and tension: Stretch or tension measured in the warp direction of the fabric.

Warp-faced twill: A twill weave in which the warp yarns produce the diagonal effect.

Warp knit: See **Warp-knitted fabrics**.

Warp knit fabric: A fabric that is knit with the yarns running lengthwise, e.g., tricot, milanese, and Raschel.

Warp knitted Terry: This is a warp knitted fabric and is made with an extra warp sheet of pile yarns which are caused to form loops bound into a ground fabric. Applications include furnishings and bedsheets.

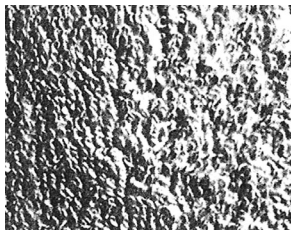

warpknitted terry

Warp knitted plush or velour: In this warp knitted fabric, the pile loops are cut to give a fleecy or velvet like surface. Applications include beach, leisure and sports wear and ladies outer wear.

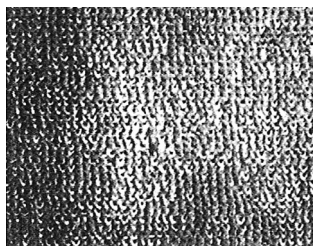

Warpknitted plush or velour

Warp knitted velour: See **Warp knitted plush**.

Warp patterned carpets: Multi-coloured machine-woven carpets in which the pile yarns are dyed using the Warp dyeing process.

Warp pile: The extra set of warp yarns that forms the surface in a double-woven pile fabric, including types such as velvet and velour. Upholstery fabrics such as mohair, plush, and friezé are produced by this method. Also see **Pile** and **Velvet fabric**.

Warp Print: Same as **Chine**. (Chiné printing). Printing the warp thread system of woven fabric with thin print pastes (complete print penetration), drying, and then, in most cases, weaving immediately (to avoid extreme pattern displacement). Dye setting and washing processes are carried out once the fabric has been woven. Small pattern displacements are inevitable, and they produce the characteristic blurred and slightly jagged appearance. This technique is used in particular for articles where complete print penetration is required (e.g. curtains). Two-phase print processes are frequently used for warp printing.

Warp printed carpet: A true warp printed carpet is a wire carpet. The pattern is created before weaving, using the Warp printing technique on the pile warp

yarns. This type of warp printed carpet (tapestry or velvet- type carpets) typically exhibits settled patterning.

In contrast to this, multi-coloured printed carpets have a certain degree of pattern bleed after weaving.

Warp printing: See **Warp print**.

Warp printing process: A Variant of Space dyeing.

Warp rib tricot: Tricot with ribs running in the direction of the warp (lengthways). The opposite of this is Transverse tricot.

Warp Ribbed: Fabrics having ribs or cords running in the direction of the warp.

Warp side: In a loom, the back of the machine is where the warp beam is called the warp side.

Warp Stitch: In embroidery, a stitch by which warp threads are drawn together to form a pattern after some of the weft threads have been removed.

Warp sheet: A sheet comprising up to several thousand ends that are combined to make up the warp during preparation for weaving or warp knitting.

Warp Sizing: Sizing of the warp in wovens in preparation for the weaving process. The evenness is particularly useful in practice for reasons relating to technology and economy. For this reason the aim is to reduce unevenness in the sizing along the warp.

Warp Sizing and dyeing: Process for dyeing cotton warp during sizing. Only used for a few types of fabric, such as denim, blue jeans.

Warp streak, in woven fabric: A narrow band running lengthwise and characterized by apparent differences in colour from the adjoining ends. Warp streaks should not be confused with reed marks.

Warp stripes: The one or more faulty threads giving rise to zones of different aspect; it can be due to scraping or rubbing from members of production machines or to inaccurate reeding.

Warp velvet: (wire velvet, velours). Smooth or patterned Velvet, in which the pile layer consists of an additional warp system (pile warp).

Warper-Sizer-System: The warp yarn runs from the warping reel frame straight into the sizing machine with no sectional warping process. This means that each thread in the multi-thread warp is sized individually. This system is particularly suitable for warp preparation of untwisted synthetic fibres (e.g. fine titre of polyamide and polyester threads).

Warpers beam: In a beam warping process as an intermediate stage warpers beam which may contain upto 1000 ends are produced.

Warping: Whereas warp threads with the required sett are wound individually onto the sectional drum or a sectional warp beam in Sectional warping, there is also a type of warping where the warp yarn is wound onto warping beams to the intended weaving width but with a reduced sett. More and more beams of this type are being consolidated into a standard warping beam. This technique is primarily suitable for long warps of a single colour. Multi-coloured yarns are usually warped sectionally.

Warp-knit: Warp-knitted fabrics.

Warp-knit nonwoven pile fabric: Nonwoven knitted fabric consisting of a basic material with additional nonwoven fibre. The nonwoven fibre is bonded into the basic material by forming it into pile loops.

Warp-knit stitch-bonded nonwovens: (stitchbonded nonwovens). Nonwoven knits consisting of fibre fleece, bonded by means of a row of sliding needles with tongues that are pushed into and pulled out of the fabric, causing loops of fibre (stitches) to be formed.

Warp-knitted Fabric: Textile fabric manufactured from one or more thread systems by forming stitches. Warp-knitted fabrics, unlike Weft-knitted fabrics or knit goods (single-thread knits), are formed into stitches from several adjacent threads (warp) at the same time. The process of forming stitches is less time consuming than in weft-knit manufacture, and it is not possible to chafe the fabric.

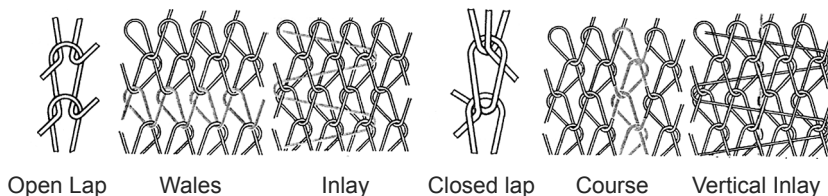

Warp knitted fabrics are made with at least one sheet of warp yarns. Usually there are two sheets of warp each on its own beam. Each individual yarn is drawn through a guide which is mounted on a guide bar. Movement of the guide bar lapping cause the thread to be lapped around the needle which may be bearded, latch or compound needle. After the yarns are lapped the needle bar is moved so as to cause the loop to be formed simultaneously at all the needles resulting in a whole knitted course. Finally the guide bar is displaced sideways (shogged) by one or more needles before the next cycle produces another course. Shogging of the guide bar determines the structure of the fabric.

Warp-knitted spacer fabrics: Warp-knitted spacer fabrics are normally manufactured on double needle bar Raschel machines (with gauges between 22 and 32 needles per inch) by knitting the face and back layers simultaneously on each needle bed, with guide bars passing between the needles of both beds as they oscillate from the front to the back of the machine. The setup involves guide bars 1 and 2 knitting the front fabric layer on the front needle bar only, and guide bars 5 and 6 knitting the back layer on the back needle bar only. Guide bars 3 and 4 carry the spacer yarns and knit on both needle bars in succession.

Warp-knitting: See **Warp knitted fabric.**

Warp-to-filling seam: A sewn seam in which warp yarns are perpendicular to the sewn seam on one side of the seam and parallel to the seam on the opposite side of that seam.

Warp-to-warp seam: A sewn seam in which yarns in the warp direction on both sides of the seams are perpendicular to the seam.

Warping board: It is a square frame with evenly spaced sturdy pegs along the sides of the frame and pegs that can accommodate a cross along the top and the bottom. Warp threads are wound on the board in order and measured by a designated path around the side pegs.

Warping order: The smallest number of ends in colour and/or count that repeats across the fabric.

Warping paddle: It is a device that allows the winding of multiple warp ends in the same pass around a warping board while keeping them separate and aligned and providing a cross of individual ends. One type of paddle is equipped with two rows of holes that keep the threads separate; the cross is picked by hand at the cross pegs on the warping board. Another type had alternate slots and holes that keep the threads separate and also form a cross of individual ends when the paddle is raised and then lowered at the cross pegs.

Warping reel: Warping reel can also be used to wind the warp. Some reels are vertical; the reel spins on a vertical axis and the warp is wound around it through a path that goes from the top to the bottom of the reel and back again. Some reels are horizontal; the reel spins on a horizontal axis and the warp is wound around it from one end to the other and back again. Reels can accommodate longer warps than boards and can be faster to use (the longer the warp, the greater the savings in time).

Warping, sectional: See **Sectional warping.**

Warping sticks: are thin slats of smooth wood about 1/8" thick, 3/4" wide, and longer than the width of the warp.

Wash & wear or easy care: A generic term applied to garments which satisfactorily retain their original neat appearance after repeated wear and suitable home laundering with little or no pressing or ironing. See **Wash-and-wear**.

Wash and wear finishing: The finishes applied on cotton, linen, viscose and its blends with synthetic fibres to achieve the effect on the fabric which can be used directly after washing and drying (without ironing). Resin finishing agents, catalysts and additives, applied using low-cost process techniques combined with mechanical finishing phases still ensure the best wash and wear finish (See **Resin finishing**). There are different levels of finishes in this which is ascertained using wash and wear standards. See Wash and wear standards.

Wash and wear standards: Photographic and three-dimensional standards for the assessment of wash and wear properties. AATCC 124-1973: Smoothness of textiles. AATCC 88B-1973: Appearance of garment seams. AATCC 88C-1973: Appearance of ironed creases on garments, in each case after domestic washing. Samples for testing of specified sizes are washed under defined conditions, dried (drip dried, spin dried, tumble dried) and allocated the grades relating to the comparative standard (1–5). 1 is the lowest grade possible, and 5 is the highest (Monsanto crease photographs).

Wash fastness testers: Mechanical instruments for measuring wash fastness. Consist of a water bath, in which sealed stainless steel or glass containers rotate on a horizontal axis. The containers hold the sample with the prescribed test solution, and possibly a set number of steel balls. Usually also suitable for testing other types of fastness (e.g. peroxide washing, hypochlorite washing, milling fastness, dry cleaning fastness, etc.).

Wash fastness testing: Test to establish the resistance to all types of industrial and domestic washing. The specimen is treated together with control fabric samples in a suitable mechanical washing device. After the test is completed, the specimen is rinsed twice in cold distilled water, squeezed, rinsed for 10 min in flowing water, the specimen is opened on 3 sides, dried at max. 60°C and then assessed (using grey scales to check the colour change and level of bleeding).

Wash liquor: An aqueous detergent solution used for the physical removal of extraneous substances from textile materials

Wash/rub test: Test for pigment dyes and prints, by rubbing with the washing solution to check the adhesive properties of the binder.

Wash satin: A soft, fine, inexpensive, white, cream or flesh-coloured satin, made from silk or, more usually, acetate, or triacetate. It washes and irons well.

Wash-and-wear: A generic term applied to garments which satisfactorily retain their neat appearance after repeated wear and suitable home laundering with little or no pressing or ironing. A wash-and-wear garment is essentially free from undesirable wrinkles both during wear and after laundering and retains any original pressed-increases or pleats. The garments should meet normal consumer demands for durability, colour, stability, and shrinkage. The performance of a wash-and-wear fabric or garment depends on several factors, including the types and amounts (percentages) of fibres used, the fabric construction, the finishing treatment, the presence of a coloured pattern (either woven or printed), and the methods used for washing and drying. These factors determine, in any specific instance, if a fabric or garment's performance will meet customer requirements. Variable conditions result in the varying behaviour of a specific fabric or garment. Garments are labeled to specify the appropriate care for optimal performance.

Wash-and-wear finishing: See **Resin finishing**.

Wash board, in hosiery: A roddy effect caused by uneven tension between feeds on the knitting machine.

Washable goods: Washable textiles, divided into the following categories: Coloured articles wash; Delicate articles; Laundry for 100°C wash. See: **Wash and Wear; Machine-washable wool**. Care labeling of textiles provides information regarding washability.

Washable suede: Particularly useful if colours are pale. Suitable for most garments.

Washdown: A change in appearance to give a worn or laundered look resulting from washing, scouring, chemical, mechanical, or other treatment, including any combination of such treatments.

Washer wrinkles: See **Crowsfeet marks**.

Washfast acid dye: A vague term for a group of acid dyes that have good washfastness properties. This term is sometimes used by dye sellers for a group of dyes selected for good washfastness properties. Often the dyes come from the pre-metallized, milling or reactive classes.

Washing: Process in which heavy or slight soiling is removed and transferred to the water in the form of a solution or dispersion. Washing has the effect of cleaning surfaces. The resulting effect is several physical/ chemical processes.

Washing agents: Washing agents or Detergents remove fat and soiling substances from textiles. In the context of textile finishing, detergents are specially adapted to suit each finishing process, e.g. for raw wool scouring, washing after dyeing and printing, etc. Laundry and domestic detergents are specifically included under the category of detergents. Domestic detergents can be classified depending on their use into the following categories: Heavy duty detergent; Mild washing agents; Special washing agents. Depending on the method of manufacture, detergents can be classified as mix and spray (cold and hot sprayed) products. Depending on consistency there is a distinction between detergents in powder form and liquid products.

Washing agent additives: The chemicals and filling agents added in the washing agent formulation mainly for enhancing the versatility of the washing agent. Main additives used are builders (try polyphosphates, Na-Al silicates), bleaching agents (soda perborates), bleach activators (TAED), others CMC, Sodium sulphate, sodium silicates, enzymes, perfumes, pigments, optical brighteners etc.

Washing detergents: Products manufactured from Surfactants; Phosphates; Perborates or alternative products and other complementary components as specified by the Detergent and Cleaning Agent Law. They act in conjunction with water to produce a cleaning effect, or are intended for cleaning (according to an additional suggestion: or products that can be used as additives and auxiliaries in washing and cleaning processes), which can finish up in environmental waters after use. The definition also includes particular textile and leather auxiliaries and industrial cleaners.

Washing lubricants: See **Textile lubricants**.

Washing machine methods: (1) Machine wash: A process in which products or specimens can be washed, bleached dried and pressed by any customary commercial or home methods, including a sour rinse commonly used in commercial laundering. (a) Hot: Initial water temperature directly from hot water tap from 54–66°C (130–150°F). (b) Warm: initial temperature setting 32–34°F (90–110°F) hand comfortable. (c) Cold: Initial temperature setting same as cold water tap up to 29°C (85°F). (2) Home launder: Same as (1) but exclude commercial laundering. (3) Small load- Smaller than normal washing load. (4) Delicate or gentle cycle: Slow agitation and reduced time. (5) Durable press (Also permanent press) cycle: Cool down rinse or cold rinse before reduced spinning. (6) Separately: Wash alone or with like colours. (7) Wash inside out: Turn the product inside out to protect face of the fabric. (8) No bleach: Excludes all bleaches. (9) No chlorine bleach: Permits bleaches other than chlorine. (10) Warm rinse: Initial water temperature setting

32–43°C (90–110°F) (11) Cold rinse: Initial water temperature setting as cold water tap upto 29°C (85°F). (12) Rinse thoroughly: Rinse several times to remove detergent and soap. (13) No spin: No spin: Remove material start of the final spin cycle. (14) Do not use roller wring nor wring by hand.

Washing off: The removal of scouring agents, preparations, sizes, chemicals, textile auxiliaries, non-set dyes and finishing agents. Washing off has a high level of influence on water use, and therefore also on costs and the problem of waste water. With discontinuous washing off, the textile stays in a machine and the washing and rinsing liquors are added or exchanged. Keeping the liquor ratio as short as possible lowers water consumption. With continuous washing off, the textile runs through several individual machines or sections, and the rinsing liquor is directed in counter-flow, i.e. there is a fresh water supply at the point at which the textile leaves the machine. Turbulence is used to ensure that the liquid lamella between the textile and the liquor is constantly broken up (increasing kinetic energy).

Washing powder: Specific term for Washing agents in powder form.

Washing soda: Sodium carbonate. Washing soda, if “pure”, is usually sodium carbonate decahydrate ($\text{Na}_2\text{CO}_3 \cdot 10\text{H}_2\text{O}$). Retail washing soda may contain additives such as detergents, salt and optical brighteners, and is therefore not a good substitute for soda ash for dyeing.

Wash-n-wear: See **Wash-and-wear**.

Wash-off factor: (C_0/C_n), this refers to the fact that the chemical/soil concentration C_0 is taken into account at the point of fabric in feed, and the residual concentration C_n at the point of fabric exit. C_n is reduced by the concentration of substances to be washed off the fabric in the machine to the value. $C_n = \text{initial concentration/wash-off factor}$.

Wash-out jeans: Denim garments that change in appearance after a domestic wash cycle. One variant of the pigment dyeing process is the wash-out finish. This consists of pigment dyes to shade depth that are manufactured using reduced quantities of binders. Fabrics are only subjected to a washing process (mill-wash, stonewash) when they have been partially made up into a garment, but usually this is not done until the garment is fully made up. The formulae for these articles, in particular washing methods, vary from firm to firm, and are usually trade secrets.

Washing, Hand methods: (1) Hand wash: Products must be laundered by hand with gentle squeezing action and can be bleached dried and pressed by any customary methods. (a) Cold: Initial water temperature as cold tap water up to 29°C (85°C). (2) Separately: Initial water temperature

32–45°C (90–110°F) (a) Cold: Hand wash alone or with light colours. (3) No Bleach: Excludes all bleaches. (4) No Chlorine Bleach: Permits use of other bleaches. (5) No wring or twist Handle to avoid wrinkles and distortions. (6) Rinse thoroughly: Rinse several times to remove detergent soap and bleach. (7) Damp wipe only: Surface clean with damp cloth or wipe sponge.

Waste: A material removed, rejected, or otherwise lost in various manufacturing processes.

Waste water: Strictly speaking, water that is soiled by domestic, commercial and industrial use, as well as drain precipitation water from built-up land (roofs, roads), contains impurities in solute, colloid and solid forms.

Waste, burr-wool: See **Burr-wool waste**. Waste removed by the burr guard of cards or burr pickers having a very short fibre and full of burr and seeds. The nature of waste varies according to the wool from which the burrs are taken.

Waste, card: See **Card waste**. Short fluffy waste thrown out of the carding machine.

Waste, cotton: See **Cotton waste**. Material removed from seed cotton ginned lint. Or stock in process by any cleaning or processing machinery and usually consisting of undesirable fibres or a mixture of cotton fibres with foreign matter.

Waste, hard: see **Hard waste**. Waste from reeling, warping, winding, weaving and cop bottoms.

Waste, invisible: See **Invisible waste**. Weight loss due to dust, moisture, loose fibre etc. Carried away by the air stream during the cotton testing.

Waste, lap: See **Lap waste**. Waste of long fibres formed in drawing and spinning processes by the breaking of the ends between the front rollers and the bobbins. This may be reprocessed.

Waste, soft: See **Soft waste**. Waste from slubbing, roving and wool tops.

Waste, spinners: See **Spinners waste**. Broken and tangled threads and lengths of yarn left on bobbins and spinning machinery in the manufacture of yarn.

Waste, sweeping: The sweeping from the floors of the various rooms in the mill. This is usually of a short and fluffy character.

Waste, thread: See **Thread waste**. The waste left on bobbins or collected during spinning and weaving. (See also waste, thrum; Waste, hard etc.)

Waste, thrum: See **Thrum waste**.

Waste, visible, in cotton testing: See **Visible waste**. Foreign matter deposited in the waste boxes of the machines during testing.

Waste water: Strictly speaking, water that is soiled by domestic, commercial and industrial use, as well as drain precipitation water from built-up land (roofs, roads), contains impurities in solute, colloid and solid forms.

Waste water load: Amount of impurities. Pollution in flowing water containing substances that consume oxygen (Waste water; Waste water pollution; Summation parameters). Calculated as a quotient of the limiting value per head of population and low water drainage.

Waste water pollutant load: Calculation of Waste water pollution, waste water quantity/unit time. Conventional value is the Population equivalence.

Waste water pollutants: They are aggressive, toxic and inorganic and organic compounds as well as their ions which impede biodegradation (See **Waste water pollution**). Given as a concentration in mg/l. Permitted waste water threshold limit values for discharging waste water pollutant are aimed at the required protection of the sewerage system, biological and the outfall channel. See **Waste water treatment**.

Waste water pollution: (1) Contaminants accumulating in waste water. Stemming from textile finishing substance burdens in the waste water: dyes (absorbable, non-absorbable), acids, alkalis and neutral electrolytes, oxidants (chrome compounds, bleach liquors, nitrites, nitrates, etc.), reducing agents (sulphur compounds), plastic emulsions/dispersions, finishing agents (e.g. fermentable starch products), metal salts, especially salts from heavy metals (toxic substances) such as copper, chrome(III), chrome(VI), mercury, lead, zinc, zirconium and such ions. Textile auxiliaries/wetting agents, surface-active substances, thickeners, lubricants/oils, sequestering agents and phosphates, tannin-like products amongst others. (2) Results from domestic, technical and agricultural water consumption as well as polluted rainwater.

Waste water pretreatment: Hydrocarbons and colloiddally dissolved dyes as well as some auxiliaries can be flocculated by the addition of electrolytes, e.g. iron or aluminium salts. The pH should also be controlled to complete the precipitation and a suitable flocking auxiliary added. This is waste water pretreatment.

Waste water treatment: Waste water treatment methods are classified as follows:

(1) Physical (mechanical): (a) sedimentation, (b) filtration, (c) distillation, (d) sorption, (e) freezing out. (2) Chemical: (a) neutralization, (b) ion exchange, (c) oxidation, (d) reduction, (e) catalysis. (3) Biological: (a) aerobic treatment, (b) anaerobic treatment, (c) activated sludge process, (d) fungus treatment.

(4) Physical/chemical: (a) flocculation and precipitation (coagulation), (b) ventilation, (c) activated carbon filtration, (d) foam fractionation, (e) solvent extraction, (f) combustion, (g) osmosis, h) electrolysis.

Watch Pocket: A small pocket in the garment, typically located just below the front waistband of men's trousers and used to accommodate change or a pocket watch.

Water: The chemical compound H_2O , widely available anywhere in the world.

Water alkalinity: If the titration of a 100.0 ml water sample with 0.01 M sulphuric acid consumes V ml of acid, the alkalinity is given by:

$$\text{Alkalinity} = 10 \times V \text{ ppm CaCO}_3$$

Water calendar: See **Water mangle**.

Water crimp: See **Crimp, types of**.

Water decarbonisation: Removal of temporary hardness (Water hardness salts) using appropriate. Water softening process, e.g. so-called lime decarbonisation via precipitation process or so-called hydrogen decarbonisation with ion exchangers, which contain carboxyl groups and work according to the principle of desalination.

Water degasification: Release of dissolved gases: air, oxygen, carbonic acid, etc.

1. Mechanical: watering, vacuum. 2. Thermal (especially for atmospheric oxygen): heating above 100°C (high pressure enclosed vessels or low pressure at $40\text{--}60^\circ\text{C}$). Residual oxygen content approx. 0.5 mg/l, practically no free carbonic acid.

Water demanganizing: Manganese content rarely exceeds 1–2 mg/l, but often becomes unpleasantly noticeable in quantities of 0.1 mg/l in mains water. Manganese makes dark brown stains, which are difficult to remove.

Water desalination process: See **Ion exchanger**.

Water equilibrium: Term in dry cleaning for the final state of water distribution between treatment liquor and textile.

Water fastness: Resistance of dyeings and prints to the effects of water.

(1) Light strain (DIN 54 005-73): test sample with adjacent fabrics well moistened (surplus water poured away), 1 hour weighted with 4.5 kg tested at 20°C , separated and dried at 60°C and assessed using grey scales.

(2) Heavy strain (DIN 54 006-73): as 1., but tested for 4 hours at 37°C and/or 16 hours at 20°C . AATCC test: 18 hours. Assessment using grey scales.

The perspirometer from AATCC (Atlas Electric) or the hydro test equipment (Schröder) is used as the tester.

Water glass: (Sodium silicate), is produced by melting quartz sand (SiO_2) and sodium carbonate, whereby approximately the following ratio exists in the product which is of interest to the textile industry: 8% sodium oxide and 27% silicon dioxide. The exact structure of water glass cannot only be given by 37–40°Bé, but it is well-known that the structures SiO_2-3 , a chain structure, and Si_4O_6-11 , a band structure, represent the main constituents.

Water hammer: **Water hammer** is produced in steam and condensate return piping by rapidly moving/retarded water drops or by combination of steam and hot condensate with colder condensate.

Water hardness: Hardness is defined as the presence of soluble calcium and magnesium salts in the water. If these are present in the form of bicarbonates, the hardness is temporary. Permanent hardness arises when water contains soluble salts of calcium and magnesium such as chlorides and sulphates. It is unaffected by boiling the water. The use of hard water in a textile dyeing or finishing mill can have some serious consequences. These include:

- (a) precipitation of soaps;
- (b) redeposition of dirt and insoluble soaps on the fabric being washed – this can cause yellowing and lead to unlevel dyeing and a poor handle;
- (c) precipitation of some dyes as calcium or magnesium salts;
- (d) scale formation on equipment and in boilers and pipelines;
- (e) reduction of the activity of the enzymes used in desizing;
- (f) decreased solubility of sizing agents;
- (g) coagulation of some types of print pastes;
- (h) incompatibility with chemicals in finishing recipes.

Water hardness , degree Of: See **Water hardness scale**.

Water hardness scale: The definition of one degree of hardness, however, varied from one country to the next. It is much simpler to express hardness in mg/l or ppm of CaCO_3 .

Various units used for water hardness

Unit of water hardness	ppm CaCO_3
1 British degree	14.3
1 American degree	17.2
1 French degree	10.0
1 German degree	17.9
1 mmol/l CaCO_3	100

Water hardness units: See **Water Hardness scale**.

Water hardness, Determination of: Complexometry offers a suitable method for total, calcium and magnesium hardness, which works simply, rapidly and accurately (0.05°d). See **Water hardness salts**.

Water hardness salts: Water-dissolved calcium and magnesium salts (total hardness) cause the “hardness” in water. The hydrogen carbonates break down when boiled by releasing the carbonic acid holding them in solution (temporary, carbonic acid or carbonate hardness). The remainder is resistant to boiling (permanent, mineral acid or permanent hardness). Magnesium salts produce magnesium hardness; calcium salts, calcium or lime hardness. The units of hardness are different depending on the country and are usually given in mVal = millival (Water hardness units).

Water jet weaving machines: These machines are produced only by few companies and are used for the manufacture of light and medium weight fabrics with standard characteristics and in water repellent fibre materials, primarily multi-filament synthetic yarns. These machines use water jet for weft insertion. Water jet machines are extensively used in East Asia, but have limited importance in other countries. They are characterized in particular by high insertion performance and low energy consumption.

Water lock: The installation of a water seal prior to the delivery of fabric from a steamer ensures an air free passage of the latter through the steamer, e.g. by immersing the lower exit rollers inside the steam chamber in the liquor contained in the 1st after treatment bath.

Water mangle, water calendar: A mangle with two squeeze rolls for the dewatering (pre-drying) and simultaneous smoothing of textile fabrics. A water mangle is often used before drying piece goods in rope form after pretreatment.

Water marking: See **Pile reversal**.

Water marks: (1) Differences in light reflection from a textile fabric caused by the action of otherwise harmless water sprays or water drops. The effect is due to a temporary swelling which occurs particularly with regenerated cellulosic fibres sensitive to wetting. (2) Moiré effects caused by the pressure of one layer of fabric on another. (3) Undesired marks due to the presence of wet spots on a textile fabric prior to continuous dyeing (or beam dyeing) which reduce dye uptake in localized areas. (4) Variations in the pile orientation of pile fabrics causing differences in light reflection.

Water of crystallization: (water of hydration). Water which is chemically combined in many crystalline substances. This water may be held in the

crystal in various ways. Thus, the water molecules may simply occupy lattice positions in the crystal, or they may form bonds with the anions or the cations present.

Water pockets: If batch rolls containing wet fabric in the open-width state are inadvertently kept standing during, e.g. a prolonged machine stoppage in wet sheets, tenting, tarpaulins, etc. This term must not be confused with the term Water repellent.

Water softening: Removal of *hardness* from water. The calcium and magnesium ions can be removed by chemical precipitation. Alternatively, cation *ion exchange resins* can be used to exchange the calcium and magnesium for sodium ions. Ion exchange resins that exchange other cations for hydrogen ions, produce an acid water, because the bicarbonates, sulphates and chlorides become carbonic acid, sulphuric acid and hydrochloric acid. However, by mixing this with hard water all the bicarbonates in the raw water can be removed and the acids in the softened water are neutralised—e.g. $\text{Ca}(\text{HCO}_3)_2 + \text{H}_2\text{SO}_4 = \text{CaSO}_4 + 2\text{H}_2\text{O} + 2\text{CO}_2$

The carbon dioxide can be removed by aeration. This process reduces the *carbonate hardness* to zero, although some *non-carbonate hardness* remains.

Water treatment: *Screening*, then *coagulation, flocculation* and *clarification* or *dissolved air flotation*, followed by *filtration* and *disinfection*, is a typical treatment which converts raw water to drinking water. It removes colour, suspended and *colloidal* matter from reasonably clean water but cannot reduce their *salinity* without *desalination*. A range of other processes may be used in water treatment to remove specific ranges of contaminants in the water. Examples include *activated carbon filters, ion exchange* and *membrane processes*. The *sedimentation* that occurs during *raw water storage* can also be regarded as part of the water treatment.

Waterproof: A term applied to materials that are impermeable to water; waterproof fabrics have had all their pores closed and are also impermeable to air and very uncomfortable.

Water proof finish: The production of a Water repellent finish (analogous to a waterproof or water pressure resistant finish) on a textile fabric. Waterproof and water repellent finishes.

Waterproofing: The production of a Water repellent finish (analogous to a waterproof or water pressure resistant finish) on a textile fabric. See **Waterproof and water repellent finishes**.

Water quality for dyehouse: The typical water quality for textile processing can be summarised as below:

Typical Dyehouse Water Quality

Component	Permissible Concentrations, mg/l
Hardness	0–25 CaCO ₃
Iron	0.02–0.1
Manganese	0.02
Silica	0.5–3.0
Alkalinity to pH 4	35–65 CaCO ₃
Dissolved solids	65–150

Water repellency: The property of a fibre, yarn or fabric characterised by its resistance to wetting by water. Water Repellency is more difficult to define because various static and dynamic tests are used to measure water repellency. Generally speaking water repellent fabrics are those which resist being wetted by water, water drops will roll off the fabric. A fabric's resistance to water will depend on the nature of the fibre surface, the porosity of the fabric and the dynamic force behind the impacting water spray. The conditions of the test must be stated when specifying water repellency. It is important to distinguish between water-repellent and water-proof fabrics.

Water repellency Test: (1) A severe test method for textiles with a hydrophobic (water repellent) finish. Procedure: a specimen of the textile fabric is lightly stretched over a wooden frame inclined at an angle of approx. 15° (attached to a glass plate with a rubber band if necessary) and placed 50 cm below the outlet of a dropping bottle. Water drops (previously adjusted to a rate of 100 drops/s) are allowed to fall on the same area of the textile specimen until a perceptible wetting occurs (as indicated by a darker colour in the wetted area). Good water repellent impregnations should be able to resist at least 20 of these drops without any wetting. Alternative: Spray test. (2) This test method is used for the evaluation of water repellent and waterproof finishes. The test is based on the principle of subjecting a textile test specimen to the action of simulated rain with simultaneous rubbing on the underside of the fabric. The water repellency of the fabric is assessed by measuring the water absorption (%) and the quantity of water which has passed through it (simulated rain values). Pfersee testing instrument; Hydrophobic finishes, evaluation of; Spray test.

Water Repellent: Fabrics that have been treated with a finish which cause them to shed water and resist water penetration, but are still air-permeable. Treatments can include wax coatings, resins, silicones, and fluorine derivatives. Such treatments do not close the pores of the fabric, while waterproof finishes do.

Water repellent fabrics: Water Repellent Fabrics have open pores and are permeable to air and water vapor. Water-repellent fabrics will permit the passage of liquid water once hydro-static pressure is high enough.

Water resistant: A degree by which water is able to penetrate a fabric. Not to be confused with water-repellent. However, the terms are often used interchangeably.

Water resistance: Resistance to wetting and penetration by water.

Water retained, in textiles: The amount of water absorbed by the fibres, adsorbed on the surface of the fibres, and held within the void of the fabric after immersion, measured under specified conditions.

Water retention: The moisture remaining in and on the material after a specified mechanical treatments. In this method water retained by fibre masses includes the water absorbed from the prevailing atmosphere, water imbibed following immersion and moisture adhering to the fibre surfaces after being subjected to 1000 times normal gravitational acceleration for one hour.

Water softening: The removal from water of dissolved calcium, magnesium, and iron compounds, thus reducing the HARDNESS of the water. The compounds are potentially damaging because they can accumulate in pipes and boilers. They also react with, and therefore waste, soap. Temporary hardness can be removed by boiling the water. Permanent hardness can be removed in a number of ways: by distillation; by the addition of sodium carbonate (which causes dissolved calcium, for example, to precipitate out as calcium carbonate); and by the use of ion-exchange products such as Permutit (utilizes zeolites) and Calgon (utilizes polyphosphates).

Water-Proof Fabrics: Water-Proof Fabrics are resistant to the penetration of water under much higher hydrostatic pressure than are water-repellent fabrics. These fabrics have fewer open pores and are less permeable to the passage of air and water vapor. The more waterproof a fabric, the less able it is to permit the passage of air or water vapor. Waterproof is an overstatement, a more descriptive term is impermeable to water. A fabric is made water-repellent by depositing a hydrophobic material on the fibre's surface; however, Waterproofing requires filling the pores as well.

Water softening agents: The function of these products is to eliminate the harmful effects of Water hardness salts and other metal salts by complex formation (use of appropriate sequestering agents). Suitable products are based on salts of polycarboxylic acids, polyphosphates or preparations containing these agents. Such water softening agents are used in all fields of textile dyeing and finishing.

Water softening processes: For the removal of Water hardness salts.

(1) Cultonex process with milk of lime or lime water. In this process, the water hardness is brought down to 2–4°d by stoichiometric dosing. (2) Lime-soda water softening process with high carbonate and non-carbonate hardness. This process brings the water hardness down to 1–2°d. (3) Soda regeneration process, used specifically for non-carbonate hardness (boiler feed water). (4) Trisodium phosphate water softening process: the addition of trisodium phosphate produces a floccular sludge. Water is softened to 0.1°d by this method. V. Baryta process for water with a high non-carbonate hardness (sulphur oxide), residual hardness 1–2°d. (5) Ion-exchange processes for complete water softening.

Watt: It is defined as the power when work of 1 J is done in 1 s or an equal heat transfer occurs in 1 s. In electrical applications, 1 W is the product of 1 ampere and 1 volt. Derived units of power, electrical energy and heat are all quotients obtained from a statutory unit of energy, work or quantity of heat, and a statutory unit of time. $1 \text{ W} = 1 \text{ J/s}$, $1 \text{ W} = 1 \text{ Nm/s}$.

In the SI system, the watt has now replaced the former unit of mechanical power, i.e. horse power (HP). Conversion: $1 \text{ HP} = 745.70 \text{ W}$.

Watteline: Watteline is a very loose, soft tricot construction, raised on the back. It is used for waddings and padding between top cloth and lining.

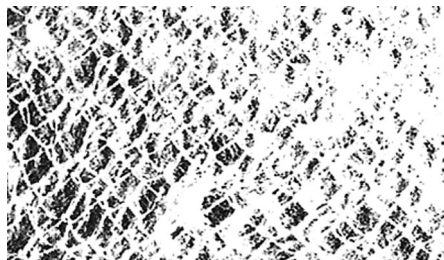

Wave: A physical activity that rises and then falls periodically as it travels through a medium.

Wave shed: A shed in a multiface weaving machine where several sheds are formed in the direction of weft and move laterally. The sheds may be formed by healds driven individually or by a series of narrow heald frames at various stages of heald timing.

Wavy cloth: A cloth that will not lie flat on a cutting table.

Wavy Face: A surface condition characterised by a considerable variation in yarn diameter.

Wavy selvage: See **Slack selvedge**. An undulating selvedge that does not lie flat. Causes: the use of different materials in fabric and selvedge, overturned selvedges due to creased edges, defective beaming, defective temple adjustment on the weaving machine, etc.

Wax: A special group of low melting, thermoplastic organic mixtures generally opaque in appearance. Some are hydrocarbons, others are esters of fatty acids and alcohols. Soluble in most organic solvents, insoluble in water. Saponification of saponifiable waxes yields Fatty acids and Fatty alcohols. Waxes form protective coverings to leaves, stems, fruits, seeds, animal fur, and the cuticles of insects, serving principally as waterproofing. For example, waxy deposits on some plant organs add to the efficiency of the cuticle in reducing transpiration, as well as cutting down airflow over the surface and forming a highly reflective surface, thus reducing energy available for evaporation. They may also occur in plant cell walls, e.g. leaf mesophyll. They are used in varnishes, polishes, and candles.

Wax resists: (wax and resin resists) are employed as mechanical resists in resist printing (especially batik articles) for the production of pure untainted white effects that are almost impossible to achieve with reductive discharges. Wax resists consist mainly of natural resins (pine resin, colophony), beeswax, ceresin, stearin, spermaceti, tallow, etc. melted with turpentine oil or rectified petroleum. They are applied to bleached fabric by hand block printing or from heated rollers with deep engravings on a printing machine. To avoid sticking and smearing, the printed material is sprinkled with kaolin, diatomaceous earth or fuller's earth. The goods are then dried by hanging in air for 2–3 days, washed cold and subsequently dyed, usually with cationic or selected acid, direct and mordant dyes as well as indigo. The dyes used must not be soluble in benzene or solvents since, after cold dyeing, rinsing and drying, a passage through benzene must be given to remove the wax (only benzene produced from benzene and toluene is suitable, not petroleum spirit).

Weak acid/Weak base: See **Acid, weak** or **Base, weak**.

Wear fastness properties: In Colour fastness testing, a distinction is made between those colour fastness properties that are of particular relevance to the end consumer, e.g. colour fastness to light, washing, chlorinated water, sea water, water spotting, perspiration, rubbing, dry cleaning, etc. i.e. properties which relate to the performance of a dyed or printed textile in use, and those which are only important in textile manufacturing processes, e.g. colour fastness to decatizing, stoving, sublimation, vulcanizing, etc.

Wear, wear and tear: When applied to textile materials, the term “wear and tear” refers to the gradual and unintentional wearing away of a textile surface

due to specific mechanical effects such as friction (textile wear resistance. See **Abrasion resistance**).

Wear level: The number of wear refurbishing cycles to which an item has been subjected.

Wear-refurbishing cycle: One complete series of events that may be terminated by laundering or dry-cleaning.

Wear-test: A test in which textiles are subjected to wear service conditions and evaluated for performance.

Weak web: A web of fibre that, when being transferred from the card doffer to the calendar rolls to form sliver, does not have sufficient strength from fibre cohesion or clinging entanglement to hold itself together while forming a continuous bridge in processing.

Weak yarn: A yarn that is found to be either below standard breaking specifications or to be weak enough to cause an abnormally high degree of stops in textile processing.

Wear resistance: See **Textile serviceability**.

Wear service conditions: The specific conditions under which a garment is worn e.g. at school, at work, at leisure etc.

Wear test: A test for fabric wear, abrasion, flexibility, washing, crushing, creasing, etc., in which the fabric is made into a garment, worn for a specific time, then assessed for performance.

Wearable Computing: Wearable computing refers to a computer that is inserted into the personal space of the user, is controlled by the user, and has both operational and interactional constancy, i.e., is always on and always accessible. Most notably, it is a device that is always with the user, and into which the user can always enter commands and execute a set of such entered commands, and the user can do so while walking around or doing other activities (Mann 1998).

Wear, wrinkle resistance: A term applied to textile fabrics which satisfactorily maintain their appearance by recovery from sharp folds, imposed during wear.

Weather: Climatic conditions at a given geographical location, including such factors as sunlight, rain, humidity, and temperature.

Weathering: (1) The action of atmospheric agencies or elements on substances exposed to them. (2) The discoloration, disintegration, etc., that results from this action.

Weathering fastness: (colour fastness to weathering). Determination of the resistance of dyeings and prints on textiles of all kinds to the action of weathering. Accelerated weathering conditions can be achieved in the laboratory by exposing test specimens to conditions that involve changes in temperature, relative humidity and radiant energy, with or without a direct water spray (simulated rain) in an attempt to reproduce changes in the material similar to those observed after long-term, continuous, outdoor exposure. A suitable test apparatus uses filtered xenon arc radiation and an additional water spray.

Weather resistance: Ability of a material to resist degradation of its properties when exposed to climatic conditions.

Weather-o-meter: An instrument used in measuring the weather resistance of textiles. It can simulate various weather conditions such as sunlight, rain, dew, and thermal shock.

Weathering is accelerated to the degree that the effects of years of normal use are attained in only a few days.

Weave: See **Weaving**.

Weather-o-meter: A laboratory testing device for determining the resistance of textile materials to weathering.

Weather resistance: Ability of a material to resist degradation of its properties when exposed to climatic conditions.

Weave pattern: A plan (drawn on graph paper) used as a guide in weaving operations that employ harnesses.

Weave, plain: A fabric pattern in which each yarn of the weft passes alternately over and under a yarn of the warp and each yarn of the warp passes alternately over and under the weft yarn.

Weave, twill: A weave characterized by diagonal lines produced by a series of float staggered in the warp direction, floats are normally formed by the filling.

Weave Structure: The weave structure is the order in which warp and weft threads go over and under each other, i.e., the interlacement. If they interlace alternately, the weave structure is plain weave.

Weavers beam: During the process of warping as an intermediate stage a warpers beam is made having up to 1000 ends are produced. The threads of 6-10 of this warpers beam are combined at the slashing (sizing) stage and wound to a **weavers beam (loom beam)**.

Weavers knot: When a yarn breaks or is otherwise discontinuous, it must be repaired and joined back together. In some cases at winding and normally at

creeling or at the knitting machine, weaving machine, a “fisherman’s” knot or a “weaver’s” knot may be used to join the ends of the yarn together.

Weavers side: In a loom, the front of the machine is where the fabric beam is called the weavers side.

Weave repeat: The smallest number of different intersections between warp and weft that, when repeated in either direction, gives the weave of the whole fabric.

Weaving: The conversion of yarn into fabric by interlacing two independent yarn systems, i.e. the warp and the weft, on a weaving machine or loom. In a weaving machine, the warp yarns are passed from a warp beam (wound warp) to the fabric beam (wound fabric).

During this process, each warp yarn is led through an eye on a heald attached to a harness. The harness lifts some of the warp yarns, e.g. the even-numbered warp yarns, and depresses the remainder to form a gap between them known as a “shed” through which the weft is inserted. This operation is known as shedding and the insertion of weft is called “picking”. The sley beats up the weft to the edge of the woven fabric.

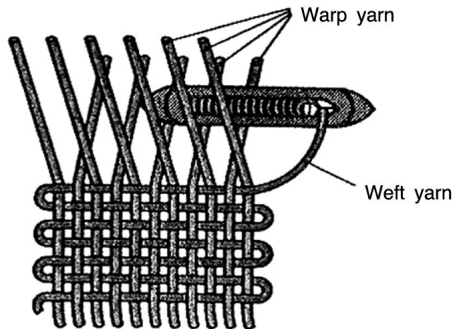

Principle of weaving

Weaving, shaft: warp sheet passes over the back rest roller and lease rods, through heald shafts and reed and over the breast beam to the cloth roller. The heald eyes of each heald shafts are threaded in a set pattern e.g., yarns 1, 3, 5, 7, 9 or yarns 2, 4, 6, 8 etc. By raising and lowering of the healds a shed is formed in the warp yarns through which the weft yarn can be drawn. For a plain weave at least two shafts are needed. After the weft has been introduced the reed beats it up into the fell of the cloth. The range of pattern which can be woven on a shaft loom, is limited by the number of shafts which can be accommodated on the machine.

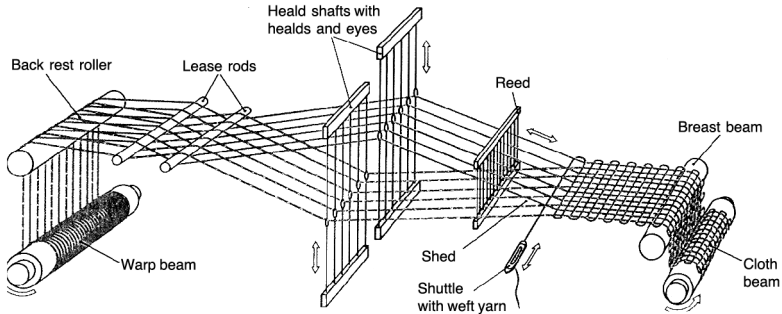

Principle of Shaft weaving

Weaving, Jacquard: The lifting of each warp yarn can be controlled individually. This is effected by either a punched card or an electronic control system according to the required weaving pattern. The technique is named after it's inventor, J.M.Jacquard a Silk weaver of Lyon.

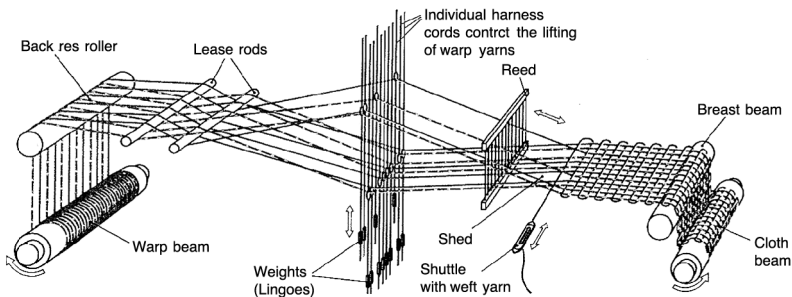

Schematic drawing of Jacquard weaving

Weaving machine, circular: In a circular weaving machine, the warp is circular and there are continuously circulating shuttles running around the periphery in a wave or ripple shed. The shuttles cannot leave the shed and have a continuous motion. Shuttles are driven electromagnetically and each shuttle runs in its own shed.

Weaving machine, double rapier: In double rapier weaving machine, the weft yarn is inserted half way into the shed by one carrier and then taken over in the centre by the other carrier and drawn out to the opposite side of the fabric.

Weaving machine, jet: In a jet loom the weft thread is propelled across the loom by a jet of water or compressed air. In this case the mass of the weft carrier, i. e. water or air jet is reduced to a minimum, say 1.5 g.

Weaving machine, multi-shuttle: A multipiece weaving machine in which the weft insertions are by shuttles.

Weaving machine, multipiece: A narrow fabric loom equipped for the simultaneous weaving of two or more pieces.

Weaving machine, single rapier: In a single rapier weaving machine, the weft insertion is done by one rapier to the full width of the warp.

Weaving, primary motions: Shedding, picking, and beating up together is called the primary motions of weaving.

Web: (1) The wide film of fibres that is delivered from the card. (2) A similar product of other web-forming equipment, such as that formed by air deposition and used to make nonwoven fabrics. (3) A term loosely used for lightweight nonwoven fabrics.

Web slitting machines: (fabric slitting machines), are used to slit running fabrics down the middle or in longitudinal strips of predetermined width. They are designed for installation on production machines.

Webbing: Strong, narrow fabric, closely woven in a variety of weaves and principally used for belts and straps that have to withstand strain (e.g., automobile seat belts, reinforcement of upholstery, suspenders, etc.). Elastic webbing is made with spandex or rubber yarns in part of the warp or filling, or both.

Webbing, elastic: A textile webbing containing rubber or other elastomers to permit rubber like stretch in at least one direction.

Webbing, in textiles: A stout narrow fabric with a mass over unit area of at least 0.5kg/m^2 (0.1 lb/ft^2) for each 25.4mm (1.0 in.) in width.

Webby Wool: A thin fleece with poor staple formation and a large number of cross fibres.

Weft: See **Filling**.

Weft: (a) Width-way threads as woven in a fabric. (b) Yarn intended for use as in (a) above.

Weft cracks: Cracks present in individual and sometimes neighbouring weft yarns in woven crêpe fabrics produced from viscose or cupro yarns. Causes: embossing conditions too severe, or fibres weakened by oxidized linseed oil sizes.

Weft detector: An electronic device for indicating: (a) The presence of weft during weaving, normally on non-shuttle looms; (b) That the weft on the pirn in the shuttle is becoming exhausted.

Weft distortion: Weft distortion is caused by external mechanical forces acting on a woven fabric (mechanical distortion) as well as internal latent tensions already contributed by the yarns themselves, or which have developed during the processes of manufacture (shrinkage distortion). – Skew distortion: a condition in which one side of the fabric is further advanced in relation to the other thereby causing a diagonal distortion of the weft yarns. Thus, although the warp and weft yarns may still be largely straight, they no longer lie at right angles to each other. – Bow distortion: a curvature in the path of the weft yarns, i.e. although the left and right ends of the weft yarns are at the same height they are displaced either forwards or backwards in the centre of the fabric in relation to the edges. – Combined bow and skew distortion: the weft follows a curved path and the ends of the weft yarns are not at the same height. – S-shaped distortion: the weft is wavy and lies in a series of small curves. It is largely dependent on the weave pattern. – Irregular distortion: the weft yarns may follow any path across the width of a woven fabric. This type of distortion usually involves a combination of straight skew and various bow-shaped components.

Weft face fabric: Any fabric in which the warp is completely covered with weft.

Weft feeders: These are intermediate feeding devices, which are also called weft storage feeders or weft accumulators, play today an important role in the new age weaving machines where the weft is unwound overhead from the cone and is subjected to abrupt accelerations due to the drawing-off tension exerted by the insertion element (rapier, projectile, fluid). The balloon which is formed at each insertion can cause coil sliding and snarls, owing to the difficulty of braking adequately the yarn and to the high unwinding speed of the yarn from the cone, which results into abrupt stresses, varying with diameter and speed variation. The present weaving speeds made thus absolutely necessary the use of an auxiliary apparatus placed between the cone and the insertion device. This apparatus positions the thread in a way as to favour its unwinding under lower stresses, and at the same time takes off from the package the necessary thread length, also making the most of the dead times between an insertion and the other, therefore with lower unwinding speeds and more continuously.

Weft fork: A mechanical device for monitoring the presence of weft during weaving, normally on shuttle loom.

Weft insertion: (1) Any one of the various methods, shuttle, rapier, water jet, etc., for making a pick during weaving. (2) A marriage of warp knitting and weaving brought about by inserting a length of yarn across the width of the knitting elements and fastening the weft yarn between the needle loop and the underlap.

Weft insertion machine: See **Weft insertion machines.**

Weft insertion systems: A distinction is made between the following weft insertion systems used on weaving machines (See Weaving): (1) Shuttles, as used in Shuttle looms. (2) Projectiles (gripper shuttles) used in projectile weaving machines (3) Rapiers used in Rapier looms (4) Jets: a) Air insertion b) Water: an intermittently directed jet of water is used.

Weft knitted fabrics: Knitted fabrics in which one or more thread systems run widthwise across the fabric forming all of the loops in each course. Weft knitted fabrics are produced on flat and circular knitting machines. Typical weft-knit fabrics include double knit, fully fashioned, interlock, jersey, knitted fleece, knitted terry, rib knit, etc.

Weft-knitted spacer fabrics: Weft-knitted spacer fabrics can be manufactured using cylinder and dial machines (circular double jersey) or V-bed machines (electronically controlled flat knitting machines). Fabrics can be produced on both machines where two sets of needles have the ability to create two individual layers of fabric that are held together by tucks. As the spacer stitches are of the tuck variety, the spacer yarn is generally hidden on the technical back of the two plain surface layers. This has the advantage of preventing a rough or harsh feel to the material.

Weft knitting: See **Weft knitted fabrics.**

Weft slubs: Consist mainly of short irregularities in the weft direction (easily visible when viewed against the light). Weft slubs are almost always caused by defective material (impurities), spinning defects (variations in yarn count or titre, differences in twist, irregular yarn, uneven yarn thickness), or defective dyeings (streaky dyeings).

Weft yarn: See **Weft, filling.**

Weft, filling: Threads or yarns running across the width of a Woven fabric (Weaving) from selvedge to selvedge and at right angles to the warp. The weft binds the warp yarns (Warp) by interlacing with them to form a woven fabric structure and also serves as a filling material. Each weft yarn is called a pick.

Weft-knit fabric: See **Weft knitted fabric.**

Weftless fabric: (ref. tyre) A sheet of parallel cords surrounded by uncured rubber compound.

Weftless tape: Advertising tape; Typing tape: A material in strip form that consists of a number of set warp threads held together by an adhesive.

Weight: The force exerted on a body by gravity.

Weight: To determine the mass of a material.

Weight, as used with fabrics: Mass per unit area.

Weight, commercial: See **Commercial mass.**

Weight, in warp knitting: The number of yards per pound of finished fabric.

Weight, fabric, finished: See **Finished fabric weight.**

Weight, fabric: Mass per unit area expressed in grammes per square metre (ounces per square yard). Also expressed in grammes per linear metre (ounces per linear yard) or inversely as metre per kilogram (linear yards per pound).

Weight of cloth: See **Weight, fabric.**

Weight per Metre: Mass per metre of the fabric. In the same construction, weight per metre will vary as per the width of the fabric. Mainly used for finding out the weight of the lot, provided the length of the lot is known. Weight per square metre multiplied by the width in metre gives the weight per metre.

Weight per square metre: Mass per square metre of the fabric. This represents the characteristic, construction, finish etc of the fabric. If we know the weight per metre, weight per metre divide by the metre in width gives the weight per square metre of the fabric.

Weight reduction: Process by which the weight of the fabric is reduced by suitable methods, usually by partly dissolving the fabric (warp or weft or both). Mainly done on synthetic fabric or their blends, where the yarn is partly dissolved, still gives enough strength to make up into garments.

Weighted silk: Silk that has been treated with metallic salts during dyeing and finishing to increase the fabric's weight and improve its drape. Over-weighting can cause deterioration of the fabric.

Weighted silk: See **Weighting of silk.**

Weighting: The addition of metallic salts to silk to increase the weight and impart a firmer handle.

Weighting finishes: See **Weighting, synthetic.**

Weighting of silk: The silk fibre has a remarkable property of absorbing certain metallic salts, still retaining much of its lustre. This process is known as "loading" or "weighting," and gives increased body and weight to the silk. Silk without weighting is known as "pure dye," of which there is little made, as such goods take too much silk.

Weighting, synthetic: Chemical principle for weighting with methacrylamide: The monomer used for synthetic weighting is often derived from acrylic or methacrylic acid. The silk weighting with acrylonitrile and methymethacrylate

has been studied and described thoroughly; in this process, starters are formed by a redox system based on iron salts (Fe⁺⁺) and hydrogen peroxide, persulphates and other substances.

Welded Shell: The outer layer of a bonded or welded garment, such as a jacket.

Welding: There are two basic methods for applying bonding or welded seams. The first method uses an adhesive film, and the application of heat to glue or laminate two substrates together. The second method involves gluing or attaching two fabrics, using ultrasonic technology. The creation and channeling of high frequency vibratory waves cause a rapid buildup of heat in synthetic fabrics to create the bonding.

Well, in buttons: The recess in the centre of a sew through flange button that gives aesthetics and identifies the face side.

Welline: (Fr. = waved) A wave-shaped Ratiné effect. It involves carded yarn ratiné material with a wave-like structure. The waves may be oriented longitudinally, transversely or diagonally. The basic material of the cloth is wool velour. In order to achieve a particularly fine effect, cashmere, mohair, camel hair or alpaca is used as upper weft.

Welsh tapestry: Brightly coloured fabrics in geometric designs that resemble tapestry-work. The cloth is double-sided and reversible, plain weave, made from coarse Welsh woollen yarns. The cloth is constructed so that, although the same colours appear on both sides, the arrangement is reversed and gives a different colouring. Used for capes, coats, blankets, shawls, cushion covers.

Welt: (1) A finished edge on knit goods, especially hosiery. In women's stockings, it is a wide band knitted from heavier yarn than the leg and folded on itself. (2) A small cord covered with fabric and sewn along a seam or border to add strength. (3) A seam made by folding the fabric double, generally over a cord, and sewing it. (4) A term sometimes used for piqué.

Welt Lining: Interlining for pocket welts.

Welt seam: A complex seam formed on the inside of the object with one trimmed raw edge enclosed and one stitching line visible on face side.

Welt stitch: See **Float stitch**.

Welled seam, in upholstered furniture: Seam sewn with a strip of covered cord between two fabric pieces, joined so that the welting shows on the exterior of the furniture unit.

Welting, in upholstered furniture: A cord covered by strips of exterior fabric, used in welted seams of upholstery covering.

West of England: Very high quality woollen cloth, produced in the Cotswold, U.K. area. The type of cloth varies, e.g. it may be flannel, and it often has a characteristic window pane check design. Used for men's suits, trousers, and overcoats, and for women's coats.

Wet and dry bulb hygrometer: If the bulb of a glass thermometer is surrounded by a wet sleeve of muslin in an atmosphere that is not saturated, water vapour will evaporate into the air at a rate proportional to the difference between the actual humidity and 100% humidity. Owing to the latent heat of evaporation, heat is drawn from the thermometer bulb, thus cooling it. This cooling effect has the consequence that the temperature indicated by a wet bulb thermometer is lower than the air temperature. By mounting two identical thermometers together, one with a wet sleeve and one with a normal bulb, the two temperatures can be read directly.

Wet cleaning: The removal of water soluble or emulsifiable soil from garments often carried out on a draining board using water in the presence of a detergent. It is also a process for cleaning garments etc. made from fabrics, e.g. vinyl coated materials liable to be damaged by dry cleaning.

Wet crease resistance: The property of a fabric whereby it does not acquire creases when squeezed in a wet state. Wet crease resistance includes an anti-creasing capacity, in other words the ability of the fabric to lose creases acquired during wear when immersed in water.

Wet crease resistant finishing: A process in resin finishing for improving wet crease resistance. Processes particularly suited for this are those which enable the cross-linking of cellulose when in a swollen state (Wet cross-linking process).

Wet cross linking process: A resin finishing process for cross-linking cellulose in a swollen state by means of hydrolysis resistant resin finishing agents in the presence of strong acid, e.g. hydrochloric acid, or strong alkali, e.g. sodium hydroxide solution, at room temperature.

Wet decatizing fastness: See **Potting fastness**.

Wet development: Fixation of dyeings and prints carried out in an aqueous medium. Prints are with vat leuco ester, naphthol and reactive dyes in particular on cotton, linen and viscose.

Wet dwell (batch) fixation: The fixation of compounds (e.g. resin finishes or reactive dyes or peroxide) by dwelling of the goods in a wet state.

Wet fastness: A collective term generally used for the demand that during use dyeings and prints exhibit colour fastness to Water, Perspiration, Washing and Wet ironing, whereby more specialist demands also include fastness to Alkali fastness of dyeings and prints; fastness to cross dyeing; Fastness to sea water as well as wet light fastness.

Wet finishing: (wet processing). The term encompasses all wet treatment processes such as bleaching, dyeing, printing, impregnation, mercerising, carbonising, milling, etc. in contrast to Dry finishing of fabrics.

Wet fixation process: A special fixation process used for prints in which the dye is applied without or with only a proportion of the fixing chemicals, and in which fixation follows without intermediate steaming and in a bath containing no, or only a proportion of, the fixing chemicals. For example: for reactive dyes, a caustic shock process; for vat leuco ester dyes, a nitrite process.

Wet forming: The production of a nonwoven fabric web from an aqueous suspension of fibres by filtering the short fibres onto a screen belt or perforated drum.

Wet impregnation: (1) See **Impregnation**. (2) See **Water-impermeable finishes**.

Wet lamination: Instead of using foil to stick together the separate layers (dry lamination), an adhesive is used which is applied to both sides of the middle layer (e.g. by spraying) of the lamination package before it enters the two-bowl padder. Once the adhesive has been heat hardened, the laminate is batched.

Wet-laid non-woven: Fabric made by the wet-forming process. The short fibres typically have more random orientation in the web and the web has more isotropic properties than carded webs.

Wet laying: The process of forming a fibre sheet by paper making technique, for nonwoven fabric products.

Wet modulus: Describes the force in cN/dtex which is theoretically required in order to stretch a fibre in a wet state by 100%. The force measured is the force which is required to stretch the fibre in a wet state by 5%, and this figure is then multiplied by a factor of twenty. A high wet modulus serves as a criterion of dimensional stability. *See* **Modal fibres**.

Wet-on-dry finishing: The application of finishing liquor to dry goods.

Wet on wet dyeing process: In a wet on wet continuous dyeing production each of a series of passes through the padder involve the application of dyes or chemical onto the wet goods emerging from the preceding pass. In wet on

wet application for example preceding padder can have a for example, 70% pick up (either wet on dry or wet on wet) next padder can have a pick up of 90% (newly acquired pick up of 20%). The advantages of this dyeing process are a saving in drying energy and a high rate of passage of steam, thus providing a significant cost reduction and making the process particularly suitable for dyeing voluminous textiles such as terry and cord fabrics. Example: The dry, absorbent terry material is passed through hot naphthanilide solution on the first padder. The preparation cools during the ventilated stage. Developing with a diazo solution follows wet-on-wet on the second padder. A ventilated stage guarantees complete reaction (diazotisation). Further process can follow as usual.

Wet on wet impregnation: The wet-on-wet technique for coating is greatly favoured in some areas of continuous finishing. The reasons for this are to be found in the undeniable advantages such as saving on drying energy and thus costs, as well as the dispensing with a drying pass, a reduction in textile handling requirements and an increase in drying capacity. The problem of entrapped air (as in dry-on-wet impregnation = wetting) does not arise here, but instead there are other problems.

Wet on wet padding: A padding process in which the material to be padded in wet, e.g. from a previous process stage. Wet on wet impregnation is slightly complicated as there will be a dilution of the bath due to the seepage of the liquor from the fabric to the bath. A proper analysis of the liquor exchanges are carried out and a stronger solution is added to the bath to keep the concentration in the bath same.

Wet on wet printing: The overprinting of two print pastes where the first is not yet dry; a common process.

Wet pick up: This is the pick-up of the bath on to the fabric by the wet on wet padding operation. See wet on wet padding, wet on wet impregnation. Usually the wet fabric will have the 2nd bath solvent on it (usually water). In a usual procedure the fabric is passed through water to even the water on the fabric and give a higher squeeze and passed through actual padding bath and the second mangle where expression is kept high (low squeeze) The pitch up will be the difference between the second mangle and first mangle.

Wet processing: A common term used in various senses, also as wet finishing:

1. Finishing using an aqueous solution (in contrast to Dry finish employing organic solvent liquor).
2. Wet treatment processes in finishing technology such as wet decatizing, kier-boiling, bleaching, mercerising, carbonising, milling, dyeing, etc.
3. As a pre-treatment for all finishing processes which precede dyeing, in other words in addition to those under II. also, for example, singeing, thermofixation, raising, etc.

Wet scrubber: The use of water to assist in the removal of dust particles or polluting gases, such as SO_2 , by contacting the dirty gas stream with liquid drops. The liquid flow divided by the gas flow is about 10^{-3} . Wet scrubbers allow particles less than $1\mu\text{m}$ to be collected on a $50\mu\text{m}$ droplet of water and then use a simple technique to remove the water droplets. The pumping of water maybe costly and the discharged wash water is polluted. For SO_2 removal, the wash water is alkaline (see **flue gas desulphurisation**). Many types of wet scrubber exist such as *baffle type scrubber, collision scrubber, cyclonic spray scrubber, ejector Venturi scrubber, low energy scrubber, moving bed scrubber, packed bed scrubber plate tower scrubber, spray chamber, Venturi scrubber*. A *dry scrubber* and *semi-dry scrubber* are techniques to minimise water usage.

Wet transfer printing: A facility for the wet transfer printing process on acrylic, polyamide and wool and comprising an impregnation padder, transfer calender (of the felt calender type) and a J-wash box. Even light and extremely sensitive qualities are suitable for this wet transfer printing process.

Wet transfer printing process: In contrast to a dry transfer printing process, the transfer of dye in the wet transfer printing process takes place by migration in the aqueous phase or in an organic phase, formed by wetting or other additives, at temperatures of $100\text{--}150^\circ\text{C}$.

Wet sizing: Conventional Sizing in contrast to Solvent sizing.

Wet soiling: The application of soil from a liquid medium.

Wet spinning: A spinning process used in the production of chemical fibres (especially viscose, cupro, polyvinyl alcohol) based on the principal of precipitation fibre formation or coagulation in an aqueous precipitation bath which takes place once the spinning solution has passed out of the spinning nozzle.

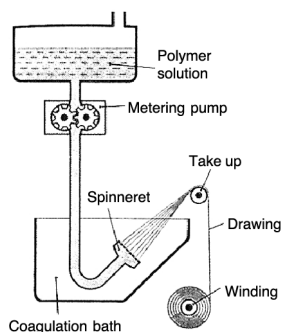

Wet spinning (Schematic)

Wet steam: Steam containing water droplets, in contrast to Dry steam. In the process house the wet steam is made by different method, one being passing the steam through water or by spraying limited fine droplets in to the steam.

Wet steamer: A steamer which can produce and use wet steam for processing. Most of the processing say, bleaching, colour fixation etc needs wet steamer.

Wet strength: The measurement of the strength of a material when it is saturated with water, normally relative to the dry strength.

Weatherometer: A testing machine used to expose thread to accelerated weathering conditions and measure its effect on colour fastness, strength and other physical characteristics.

Wet-laid nonwoven fabric: A fabric made from a fibre sheet formed by paper making techniques, normally followed by adhesive bonding. The material may contain a high percentage of non-textile. E.g. **Wood pulp**.

Wet-on-dry finishing: Most common finishing process, whereby the finishing liquor is applied on dry goods.

Wet-Spun Flax: The process of spinning line flax where the fibres are smoothed by moistening them as they are spun. Traditionally, spinners licked their fingers and drank a lot of beer. More prosaically, you can get little wooden buckets to hold the water and can hang by a leather thong from the wheel. Or even a bowl of water. You should coat the inside part of the bobbin (where the fibres wind around) with paraffin or some other sealant if you don't want to damage your bobbin.

Wether: A male sheep or goat castrated before sexual maturity. Because it's (the operative phrase) isn't caught up breeding, all of its nutrition goes into the fibre thus producing a better quality fibre. Fleeces from wethers cannot be entered into most wool shows but are worth watching for.

Wether Wool: Any fleece clipped after the first shearing is called wether wool. This wool is usually taken from sheep older than fourteen months, and these fleece contains much soil and dust.

Wettability: See **Wetting, Wetting agent**.

Wetting: The ability of a liquid to spread on a smooth solid surface is dependent on the polar nature of the solid and the surface tension of the liquid. (a) Wetting is the tendency of a liquid to spread out across a surface. A Wetting angle of zero corresponds to being fully spread out. The greater the wetting angle between solution and surface, the poorer the wetting. (b) The wetting of a solid body may be described in terms of the angle θ between it and a droplet of liquid, e.g. water, applied to its surface.

Wetting agent: A chemical that helps water penetrate a material or form a film over its surface; usually a *surfactant*. Water containing surfactants will

easily spread on paraffin surfaces and have lower contact angles on Teflon. Surfactants used this way are called wetting agents, or penetrating agents when used to wet out repellent fabrics. (A non-polar solid surface such as paraffin wax or Teflon will cause a drop of pure water to bead-up and not spread). Wetting agents are often used in dyeing to help the dye solution penetrate to the individual fibres (they don't usually help the dye penetrate from the surface of the fibre to the interior of the fibre). They can help in some fibre arts dyeing processes, but too much in a dye solution used for direct application may make the dye spread more than is wanted.

Wetting agent test methods: (1) Physical method using measurement of: (a) surface tension (simple to conduct), such as elevation method, bubble pressure method, annular separation method (Surface tension). (b) Wetting angle. Demanding and only of limited validity. (2) measurements of the wetted textile surface: (a) droplet method: a drop is allowed to fall onto a stretched sample of fabric from a micro-burette, then the patch of liquid is measured. (b) elevation method: strips of fabric, weighted at the bottom, are dipped vertically into the wetting fluid and the height of the wet portion of fabric above the fluid surface is measured after a specified time. (3) Sink (immersion) method, simple and quick: (a) (AATCC standard test method 17). (b) Hydrometer method: the increase in apparent specific gravity of the fibre is measured while the wetting liquor penetrates the fibre.

(4) Diverse: the wetting process itself is not measured, but rather the results of it, for example swelling, dimensional change, electrical conductance, etc.

Wetting angle: The angle of contact between a drop of liquid resting in contact with an even surface, the drop of liquid being in a stable state and lens shaped, and the tangent to that surface; or, in a transmission sense, the relationship of a fibre to dirt (wetting angle 90° and often almost 180°). Hydrophilic materials display a wetting angle of $0-90^\circ$, and are capable of being wetted by water. Materials which tend to be water repellent display a wetting angle greater than 90° and are thus hydrophobic (e.g. paraffin, ceresin wax with a wetting angle of $105-110^\circ$).

Wetting process: Process in which the fabric is wetted by various methods. It can be with the help of wetting agents or without wetting agents, if fabric is already absorbs water. Wetting process is necessary for many further textile processing.

Wetting promoters: These are textile additives not possessing surface activity but which nevertheless make wetting possible without accompanying generation of foam. They are absorbed by fibres and then impart the wetting process. They are known as special "air removing" wetting agents, in particular phosphoric acid trialkyl ester.

Wetting power: (wetting ability, wetting strength) The degree of capability for Wetting based on the Capillary activity of wetting agents.

Wetting properties: This is the ability of a textile surface to be wetted. A fibre may be well wetted by water if there are chemical groups on its surface which can take up water, for example because of hydrogen bridges, dipolar forces or ionic forces. Groups such as $-\text{COO}_\theta$ and $-\text{SO}_3_\theta$ are strongly hydrophilic; OH, OR, NH_2 and $\text{C}=\text{O}$ groups are weakly hydrophilic.

Wevenit: See **Double pique**.

WF: Virgin wool.

WG: Vicuna.

Whale oil: Sperm oil is a liquid wax occurring in the head of a sperm whale. Cetyl alcohol is the major fatty alcohol component of the wax ester while the acids are oleic (14%) palmitoleic (17%), palmitic (11%) and linoleic (9%). The wax oil is very stable to hydrolysis and to oxidation. Its viscosity is low so it makes an excellent lubricant. It was once the main ingredient in synthetic fibre spin finishes.

Wheat starch: A columnar, crystalline, forming a pure white homogeneous “flour” (greyer than potato starch). The handle is similar to maize starch. It is often adulterated using potato starch (detectable under magnifying glass or microscope). Its water content is 15–18%.

Wheel cast button: See **Rotation cast button**.

Wheelchair-resistant: Characteristic of a textile floor covering which enables it to withstand the pressure and abrasion imposed by a wheelchair.

Whip: The extra warp thread which forms the figures in lappet weaving. It is not interwoven with the fabric itself, except at the end of each run.

Whip roll: See **Back rest**.

Whipcord: Atwill weave fabric using bulky yarns to give a raised look to the twill ribs.

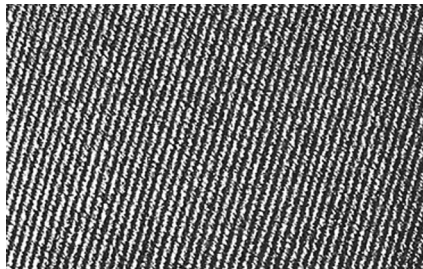

Although originally always wool or worsted, possibly with cotton filling, it is now made in any fibre, including nylon, polyester, acrylic, viscose, cotton and blends. According to fibre content and weight, it is used for making tough riding and sports clothes; light sports clothing such as tennis and Squash shorts; Children's clothes, men's trousers; and car seat covers.

Whipped cream: A type of crepe fabric produced from false-twist textured polyester yarn.

Whipped gathers: To gather, whip the rolled hem without hemming, making overcasting stitches towards you, even and not too fine. Use coarser thread than for hemming. This gathering thread is used to hold down the edge as well as for drawing up the gathers and it not to be taken out, as is the ordinary gathering thread. It should *not* catch in the roll. Have the thread the length of the plain space to which it is to be sewed and regulate the gathers as you do the gathering. After the edge is rolled, whipped and gathered, it is sewed to the garment by the little scallops or raised parts made by the whipping. This is used only for making ruffles or gathering on very fine hand work.

Whipped-in filling: See **Pulled-in filling**.

Whipping stitch: The back stitch is made by placing the needle back to the last stitch, bringing it out once the length of the last stitch, then placing the needle back into the last stitch, and so on, making the stitches follow each other without any space between. This is used in all places that are to bear great strain.

Whirled pile finish: The treatment of raw goods with special, usually round brushes for the manufacture of whirled plush fabrics (woven imitation furs).

Whiskers: Fine fibrils or crystals from polymers, metals, etc.

Whitaker process: Knit-deknit method; Space dyeing.

White: A sensory perception; according to Ostwald, the sum of all Chromatic colours and a body which reflects all visible colours.

White chate' mark: ("white abrasion"), rubbed areas on satin-like goods (especially on silk), and also frequently on poplin clothing in dry cleaning and laundry, caused by faulty mechanical influences.

White goods: A very broad term which implies any goods bleached and finished in the white condition. Some of the cotton white goods are muslin, cambric, dimity, lawn, long cloth, organdy, voile, etc.

White Light: Theoretically, light that emits all wavelengths of the visible spectrum at uniform intensity. In reality, most light sources cannot achieve such perfection.

White-on-White: Some fabrics, such as men's shirting or broadcloth, poplin, madras, etc., are made on a dobby or jacquard loom so the white motifs will appear on a white background.

White spirit: A liquid hydrocarbon resembling kerosene obtained from petroleum, used as a solvent and in the manufacture of paints and varnishes.

White wool: Wool having shade variation from true white to creamy white but free of pigmented, dyed, or otherwise coloured wools.

White, Visual assessment: Visual assessment of white is influenced by the colour of the surroundings and of the background (a light grey - i.e. neutral - plate, coloured ground or bleached and not brightened paper or cotton are best), by the angle of observation (45° to the observer is optimum), by changes of position of the samples and by personal factors. To avoid these the sampling should be done in a cabin kept neutrally grey and under standard lighting. Method a): hold the samples one in each hand at an angle of 45° ; exchange the samples several times from hand to hand. Method b): wind the samples around a glass or plastic sheet free of fluorescing or UV absorbing compounds and hold as in a; the samples overlap alternately. Method c): lay the samples next to each other flat on a white or light grey ground free of optical brightener and press flat using a glass sheet which does not absorb UV; change positions several times.

Whitener: Fluorescent brightening agents, Florescent whitening agent.

Whiteness formulae: Used in calculating the Whiteness, degree of Distinction is made between: (a) Whiteness formulae which are based directly on measured physical values, e.g. from Stephansen (not for samples treated with brightening agent): $W_{st} = 2 \cdot R_{46} - R_{62}$.

(b) Whiteness formulae which are based on colour values, e.g. from Berger: $WB = Y + 3.448 \cdot Z - 3.904 \cdot X$. These correspond better to the characteristics of the human eye.

After years of investigation the CIE has decided to recommend the following whiteness formulae. CIE whiteness formula for D65/10°: $W = Y + 800(0.3138 - x) + 1700(0.3310 - y)$

Whiteness index: The opposite of Saturation in Chromatic colours and not to be confused with Lightness even though a solid colour may appear brighter the more white it is, for example when it appears under above average illumination which causes an almost total white sensitivity as it approaches the level of being blinding.

Whiteness reduction: When a fluorescent brightening agent is added to a bleached fabric the whiteness is increased. Any factor contributing towards a reduction in fluorescence also leads to a reduction in the whiteness effect and are thus undesirable in the brightening process. The phenomenon which appears as a reduction in fluorescence is often referred to in the literature as simply 'Fluorescence quenching' or whiteness reduction. Thus, fluorescence quenching becomes a collective term describing a series of negative final effects which are brought about by, for example, an excessive concentration or the addition of foreign substances (so-called quenchers) to solutions or to absorbing agents.

Whiteness scale: A comparative series of textiles treated with brightening agent and used for the evaluation of the intensity of fluorescent brightening agents.

Whiteness value: A number which characterizes whiteness as a visual perception of white. Whiteness samples of differing appearance can receive the same whiteness value, for which reason the whiteness value can be calculated more precisely from measurements using the Whiteness formulae.

Whiteness, degree of: A dimensionless number giving a measure of White content and used as a scale for evaluating the effect of bleaching, for example, or the brightening of goods involved in dry cleaning or the colourlessness of lubricating oils and the like. The degree of whiteness is determined by various formulae for Whiteness, measurement of.

Whiteness, measurement of: Even though white is also considered as a colour it differs from the chromatic colours in the sense that white products show a high degree of brightness combined with very low colour saturation. Thus the chromaticity of white is very weak. This makes the evaluation of white samples fundamentally more difficult than that of normal dyeings. This is due to the fact that, that white is a concept of subjective quality subject to a great degree, to the influence of personal taste. A bluish white is preferred to a yellowish white provided that the two differ only in terms of their hue. Absolute evaluation differs from relative evaluation by including an exact definition of the illumination; this means the excitation of the brightening agent corresponding to an average level of daylight, and reference of the degree of whiteness and the hue calculated against an existing scale of whiteness. This method alone offers reproducibility which is adequate to all practical needs and a capacity to compare results obtained using different instruments. An evaluation using the Ganz whiteness formula has the advantage of including a correction for UV.

Whitney: An overcoating cloth made in wool. It is soft and thick with a free-finish on the rightside that produces a wavy line effect. If made from good quality woollen yarn, it is an excellent and hard wearing cloth.

Wholesalers: Essentially, businesses that buy from a manufacturer and, without changing the product, sell it in smaller quantities to retailers or smaller manufacturers.

Wick: A woven or a braided narrow fabric or a yarn or a group of yarns that has/have particularly good capillary properties.

Wickability: The ability of a fibre or a fabric to disperse moisture and allow it to pass through to the surface of the fabric, so that evaporation can take place.

Wicking: (1) Cord, loosely woven or braided tape, or tubing to be cut into wicks. (2) Dispersing or spreading of moisture or liquid through a given area, vertically or horizontally; capillary action in material.

Wicking-test: Test of the absorbency of fabrics following pretreatment for dyeing or finishing. Strips for testing are suspended vertically with their lower ends in the test liquid, and the elevation with time is measured (the wick effect). The test is important in the assessment of fabrics in minimal application techniques.

Wickproof, in tyre fabrics: A term used to describe a fabric that shows no air wicking.

Wide elastic fabric: An elastic fabric that is at least 150mm or 6 in. in width.

Width, of flat knit fabrics: The perpendicular distance between the selvages when the fabric is under zero tension and free of fold or wrinkles.

Width, of circular/ tubular knit fabrics: Twice the perpendicular distance between the enclosed edges of a flattened tube of fabric that is under zero tension and free from folds and wrinkles.

Width, of raised surface fabrics: The dimension included within the outer limits of the nap or pile, but excluding the selvages, or otherwise agreed upon by the purchaser and seller.

Width, of fabric: The distance from the outer edge of one selvedge to the outer edge of the other selvedge, measured perpendicular to the selvages while the fabric is held flat under zero tension and is free of folds and wrinkles.

Width, of fabric woven on a shuttle less loom: The distance between the outer warp on one side to the outer warp on the other side, measured perpendicular to the warp yarns while the fabric is held flat under zero tension and is free of folds or wrinkles.

Widthwise Direction, in textiles: The direction in a machine made fabric perpendicular to the direction of movement of the fabric followed in the manufacturing machine.

Wigan: Named after the English village of the same name the cloth is produced by the converter from light weight sheeting or inexpensive print cloth. A dull-finish, plain weave cotton cloth, usually in dark colours but resembling sheeting. It is highly starched and calendared, to make it stiff. Its main use is as a backing or interfacing in men's jackets, and coats, but it is not easily obtained on the roll.

Wigwan: A converted cotton cloth, dyed black, brown or gray, and given a firm starched, plain calender finish, and used for interlinings in men's and boys' clothing to give body to the garment.

Wild Silks or Tussah Silks: Produced by various silk worms or other insects which are not artificially cultivated. Such silks are often difficult or impossible to reel, are of brownish colour and of uneven diameter and stronger than mulberry silk. Most of the wild silk is torn up for waste silk and is used for pile fabrics or woven into pongee. The most important wild silks are produced in China, Japan, India and Africa.

Willesden Canvas: Plain woven cotton fabric, rendered waterproof by treating it with solution of ammoniacal copper oxide and pressing it between hot calendars.

Williams unit: A wet-processing unit for open-width processing of fabric. The fabric passes up and down over rollers in the liquor. The unit is widely used for dyeing, washing, pretreating, and after treating.

Williams unit: A variant of a type of Roller vat which has an extremely restricted liquor volume. Each assembly comprises four vertical stainless steel containers, each of a U-shaped form. The separation between the casings inside the U is only 0.5 cm, meaning that there is an extremely short liquor ratio. The liquor is heated by a steam jacket to temperatures of 90–95°C (or to temperatures above 100°C if high pressure steam or hot oil is used).

Willow: A stiff fabric woven from esparto grass and cotton; the result is similar to Sparterie. Used for making the foundations of hats.

Willey; willow; teaze: To open and disentangle fibres prior to scouring and/or carding.

Willey; Tenterhook willow; Fearnought, Teaser; Cockspur willey: A machine consisting of bladed or pinned rollers for opening cleaning and mixing staple filament fibre materials as a preliminary to scouring (for greasy wool) or carding (for most animal and synthetic fibres) various machines of

different designs exist to meet specific materials requirement. This includes Single cylinder or Double cylinder willey, Dust willey, Wool willey etc.

Wilton carpet: Woven carpet in which the pile yarns are woven in as an integral part of the carpet, being held in place by the filling, usually made on a loom with a Jacquard head. The pile may be formed by wires and hooks or by weaving between two backings, in which case, the pile ends are cut to form two separate carpets. Wilton carpets are made in two types: (1) cut pile, e.g., tournia, Wilton moquette, plush, and velvet, and (2) loop pile, e.g., Brussels.

Wimple: A band of linen wrapped around a women's head and chin, supplemented with a brow band (fillet) or crown.

Wincey: A strong fabric made of cotton warp and wool filling in plain weave or twilled; used in England for winter underwear and men's shirts.

Winceyette: A plain-weave cotton fabric that has been brushed to give a warm soft feel. It may be plain or printed. It washes well. Used for nightwear, sheets, pillow cases, babywear.

Winch: (reel, windle, winder). A device, mechanically powered or hand driven, of adjustable circumference used to wind on or off (batching, reeling) rope or yarn. According to DIN/ISO a winch is: a rotating guide or transporting structure, the circumference of which is composed of individual carrying elements. The winch may be an open or closed structure.

Winch beck: Winch with difference. The principle is as follows: The beck, or vat, has a narrow boiling chamber at the side which can also serve for the addition of dye and the like, and which is separated from the remaining liquor and the goods by means of a perforated dividing wall.

Winch, Wince: (reel, windle, winder). A device, mechanically powered or hand driven, of adjustable circumference used to wind on or off (batching, reeling) rope or yarn. According to a winch is: a rotating guide or transporting structure, the circumference of which is composed of individual carrying elements. The winch may be an open or closed structure.

Wind ratio: The number of wraps that an end or ends make from one side of the wound package back to the same side.

Wind Resistant: The ability of a fabric to act against or oppose the penetration of wind or air, but it is not totally windproof.

Wind way: The number of wraps or turns that an end or ends make from one side of the wound package to the directly opposite side.

Wind, multiple: See **Multiple wind**. The winding of two or more ends to a tube or core in parallel form so that the ends form a compact flat ribbon.

Winding: Winding is the process of transferring yarn or thread from one type of package to another to facilitate subsequent processing. The rehandling of yarn is an integral part of the fibre and textile industries. Not only must the package and the yarn itself be suitable for processing on the next machine in the production process, but also other factors such as packing cases, pressure due to winding tension, etc., must be considered. Basically, there are two types of winding machines: precision winders and drum winders. Precision winders, used primarily for filament yarn, have a traverse driven by a cam that is synchronized with the spindle and produce packages with a diamond-patterned wind. Drum winders are used principally for spun yarns; the package is driven by frictional contact between the surface of the package and the drum.

Winding a warp: Winding a warp is the process by which all the threads in the warp are measured and aligned in order. Usually this is done by placing each end in a premeasured path on a warping board or warping reel. The order of the ends is maintained by the threading cross.

Winding fallers: Any wool as shorn from the living sheep. The term is in use to distinguish this wool from other forms such as skin wool.

Winding system in open end spinning: A device which forms the yarn package.

Window panning: A fabric defect caused by non-uniform yarn. When thin sections of yarn become grouped together, the resultant increase in the transparency of the fabric is called window panning.

Windows, in Zipper: The opening in the pin lock and cam lock sliders through which the locking pin and cams, respectively, may extend.

Windproof: The ability of a fabric to be non-permeable to wind and air.

Windsor: Plain woven English fabric, made with different coloured tufts, which are introduced into the fabric in the loom with the aid of little hooked needles.

Windsor Brilliant: A washable English cotton dress goods, finished with a high lustre.

Windsor Duck: Printed duck, made in England for summer dresses.

Windsor Louisine Pine: English washable printed cotton dress goods.

Wipe, in upholstery cleaning: To clean the coated upholstery fabric with a sponge or cloth wetted with mild detergent, soap solution, or coated fabric cleaner formulated for the purpose.

WIRA: An English textile research institute

Wire Ground: The separately made raised silk net ground in hand-made Brussels lace.

Wire sleeve: A flexible dyeing sleeve made from stainless steel wire used as a package during the treatment of yarns which may shrink significantly.

Wires per unit length, In piled yarn floor covering: The number of binding sites per unit of the floor covering length. Wires in the widthwise direction being the usual means of forming the pile.

Wiry end: See **Tight twist end**.

Wiry Wool: Wool that is in-elastic and has poor spinning capacity. It is usually straight and may be the result of poor breeding.

Witch Stitch: Same as Herringbone stitch.

Witney Blanket: English woollen blankets, made with dense nap.

Witney Serge: English woollen serge, napped on both sides.

WK: Abbreviation for **Camel hair**.

WL: Abbreviation for **Llama hair**.

WM: Abbreviation for **Mohair**.

WN: Abbreviation for **Rabbit hair**.

WO: Abbreviation for **Wool**.

Wo: Abbreviation for **Wool**.

W/O: Abbreviation for oleaginous. See **Emulsions**, i.e., water in oil system.

Woad: A blue Natural dyes (a vat dye) obtained from the leaves of the golden flowering woad plant (weld, dyer's weed) and squeezed into the form of a ball. Its working ingredient is Indigo. Woad was superseded by indigo, which has 30 times the concentration of dye, at the beginning of the nineteenth century.

Wonder tape: Wonder tape is a double faced transparent tape that eliminates pinning and thread basting. It is especially helpful for positioning your quilt binding to the back, zippers, pockets and trims. Wonder Tape disappears after washing and won't gum up your needle when you sew.

Wood dyes: These are dyes used in the dyeing of various types of wood and are usually cationic dyes, acid dyes and metal complex dyes.

Wood grain: A fabric defect that consists of filling wise streaks resembling the irregular appearance of wood grain in lumber. Wood grain is usually caused by strained filling in quilling, the tension being more pronounced near the butt of the quill.

Wood pulp: The cellulosic raw material for viscose rayon and for acetate.

Wood pulp yarns: Yarns produced from wood pulp.

Woody fibre: These are the fibres in deciduous trees which lend them their strength and also serve to transport air and water. They are 0.5–1.5 mm in length, are narrow and have thick walls. Their ends are pointed. An analogy is found in components of the central lamella in →: Bast fibres; Hard fibres.

Woof: Comes from the Anglo-Saxon “owef”. It is another name for the warp or warp yarn. Sometimes in advertising textiles, the word has been used to imply filling yarn, and made to interchange with the other term, weft.

Wool: The fibrous covering of the sheep, *Ovis* species. The yarn is spun from fibres which are variable in length and randomly oriented to one another. They are intermingled and produce a bulky yarn with a fuzzy surface. Wool is popular not only for its quality of warmth. Because of its breathing properties, wool allows perspiration dry on the skin, which in turn triggers the body’s cooling effect. This also prevents perspiration from being absorbed into the fabric as happens with other fibres that have a rapid absorption rate. Very fine fibres weighing only 120–300 g per metre are now used for poplin, gabardine, panama.

Wool top: A continuous untwisted strand of wool fibres from which the shorter fibres or noils have been removed by combing.

Wool, in generic sense: The fibre from the fleece of the sheep or lamb, or Angora or Cashmere goat (and may include the so-called specialty fibres from the hair of the Camel, Alpaca, Llama, and Vicuna).

Wool base: Oven dried scoured wool free from alcohol extractable matter, mineral matter, vegetable matter, and all impurities.

Wool, carbonized and neutralized: See Carbonised and neutralised wool. A term descriptive of scoured wool processed to destroy cellulosic impurities by treating with a mineral acid or an acid salt drying and baking, crushing, and dusting out the embrittled cellulosic matter followed by neutralization of the acidified wool.

Wool, carded: See **Carded wool**.

Wool Classifier: The person who sorts the “Wool Clip” into the appropriate “Grades”.

Wool Clip: The total yield of wool short during one season from the sheep of a particular region.

Wool, combing: Wool that strong and strictly of combing length that is 2” (50 mm.)

Wool Combs: A variety of combs used to produce fibres for worsted spinning. The single-pitch and 2-pitch combs are what I call the peasant combs and are great for producing semi-worsted yarns. English combs are the multi-pitch combs (4- to 5-pitch) used to prepare a true worsted prep.

Wool content: The quantity of new and recycled wool, as defined in the Wool Products Labeling Act, which is determined by chemical analysis.

Wool crepe: Soft, drapy fabric for dresses, usually lightweight but heavier types may be used for ladies suits. A slack weave fabric with typical crepe surface. Sometimes the wrong side appears smooth by comparison.

Wool felt: A felt composed wholly of any one or a combination of new or recycled wool fibres.

Wool, Grease: See **Grease wool**. Wool taken from the living sheep and which has not been commercially scoured.

Wool Mark: The trade mark indicates goods made of pure new wool that meet the quality standards of the International Wool Secretariate. These quality assurance include fastness to light and liquid, abrasion resistance and tensile strength.

Wool, New: See **Virgin wool; Wool, virgin**.

Wool, Pulled: Wool taken from the pelt of a slaughtered sheep and which has not been commercially scoured; also called *slipe wool*; *skin wool*.

Wool, Raw: See **Raw wool**. Wool or hair of the sheep, in the grease, pulled or scoured state.

Wool, Recycled: See **Recycled wool**.

Wool, Reprocessed: See **Reprocessed wool**. The resulting fibre when wool has been woven or felted into a wool product which without ever having been utilized in any way by the ultimate consumer, subsequently have been made into fibre state.

Wool, Reused: See **Reused wool**. The resulting fibre when wool or reprocessed wool has been spun, woven, knitted or felted into a wool product which after having been used in any way by the ultimate consumer subsequently has been made into fibrous state.

Wool, scoured: Wool from which the bulk of impurities has been removed by an aqueous or solvent washing process.

Wool, tippy: Wool in which the individual staples has a spear shaped or pyramid shaped tip.

Wool, virgin: The term virgin or new as descriptive of a wool product or any fibre or part thereof shall not be used when the product or part so described is not composed wholly or otherwise manufactured as used product.

Wool Mousseline: It is made from worsted yarn into a plain or printed lightweight woo. Excellent for dresses. See also **Mousseline**.

Wool nonfelting: The nonfelting wool is produced by chlorinating the normal wool. The anti-felting effects achieved by the traditional wool chlorinating process using chlorotriazine-type products have so far not been achieved by any alternative method or product.

Wool or silk poplin: Poplin-type wool or silk material.

Wool Roller: The person in a shearing shed who skirts the fleece, then rolls it. The fleece is then classed.

Wool run: An indirect yarn numbering system, equal to the number of 1600 yd lengths per pound.

Wool stretch cord: Fabric with the appearance of ribbed tweed, but with elastane yarn woven into it. The fabric is hard wearing, comfortable, warm, crease resistant and washable. Used for men's ready-made trousers.

Wool Union: Term used for mixtures of wool and cotton and mixtures of animal hairs and natural or regenerated cellulose fibres in general (wool, mohair and other animal hairs mixed with cotton, viscose and cupro fibres). The mixing ratios of the two types of fibre can vary considerably. The term wool union is used almost exclusively in dyeing technology.

Wool-spun: Of, or pertaining to, material produced by the woollen system of yarn spinning as distinct from materials made by the worsted system of spinning.

Wool/polyester flannel: A thick warm fabric made from wool with polyester and other fibres. Used for coats, jackets, capes, children's clothes.

Woollen: (1) Of, or pertaining to, materials produced by woollen system of yarn spinning as distinct from materials made by the worsted system of spinning. (2) 'Woollen' applies to wool, reprocessed wool or reused wool.

Woollen blended: Description of yarns spun on the condenser system and having wool as a main component or descriptive of fabrics, garments or yarns made from such yarns.

Woollen card: A type of roller card used in the woollen spinning system, usually consisting of three cards in tandem: the breaker, intermediate, and finisher sections.

Woollen cloth: Fabric made of wool.

Woollen count: The two systems used to determine woollen yarn counts in the U.S. are the run system and the cut system. The run system has a standard of 1600 yards per hand, while the cut system is based on 300 yards per hank.

Woollen Cut: A woollen yarn measure. A 1-cut woollen yarn has 300 yards in one pound of yarn.

Woollen run: See **Wool run**.

Woollen spun: Of or pertaining to, materials produced by the woollen system of yarn spinning as distinct from materials made by the worsted system of spinning.

Woollen system: A spinning system employing a minimum of drafting and producing yarns of low bulk density. Roving is produced by rub aprons in the condenser section at the front of a roller top card. There is roller drafting, or other intermediate process between carding and spinning.

Woollen yarns: Yarns spun from wool fibres which have been carded but not combed or gilled.

Woolmark : International wool mark introduced in 1964 by the International Wool Secretariat (IWS) and lodged in more than 100 countries all over the world for legal protection. Guarantees pure Virgin wool and other quality characteristics. Only valid if the label is firmly sewn in and provided with a code number.

Work: Physics: product of force and distance: SI unit = joule.

Work recovery: The percent of recoverable to the total work required to strain a fibre a specified amount under specified conditions.

Work Recovery curve: See **Tensile hysteresis curve**.

Work-to-break: The total energy expended to tear apart a material.

Work to rupture: The total energy required to rupture the material.

Working elongation of rope: Elongation which is immediately recoverable when tension is removed from the rope.

Working loss: The irrecoverable loss of weight or yardage of a textile material that occurs during a textile process.

Work-to-break: The total energy required to break a measured material.

Workwear: Clothing worn for work, the wearer himself being responsible for its general condition, as opposed to Industrial protective clothing. The rules are different in Germany for personnel working in hospitals and shopping centres, etc. (representation workwear).

In this case, for reasons of safety at the workplace (particularly for personnel working near moving or rotating parts) the following rules apply: workwear must always be in perfect condition including footwear (non-slip soles).

Worn denim look: Fashion trend for casual wear, particularly for Jeans made from denim fabric such as blue warp (grey weft). Gives the impression of previously worn garments which must not only be produced by the “washout” effect (indigo-colour with the typical appearance of frequent washing = washed jeans) but also may be produced by use in wearing (“controlled” abrasion effect). This can also be achieved by gently treating with enzymes.

Worsted: Worsted yarn is spun from combed wool. Combing is a process where the shorter fibres of wool are removed and the longer ones left lying parallel. The result is smooth, even yarn. Manufacture is usually divided amongst several mills to do the combing, spinning, weaving, dyeing and finishing. Worsted yarn blends very well with other fibres.

Worsted blended: Descriptive of yarns in which the fibres are reasonably parallel and having combed wool as the main component or description of fabrics or garments made from such yarns.

Worsted card: A type of roller card user for worsted-system processing. It usually comprises two cards in tandem; the unit has a roller that carries the stock from the first card to the feed-in of the second card.

Worsted count: An indirect yarn numbering system in the worsted system equal to the number of 560 yd lengths per pound.

Worsted fabric: Fabrics made from (single or twist) worsted spun yarns in the warp and the weft. In most cases, relatively fine thread, light to medium weight, smooth and napless cloth qualities. Anything from pure virgin wool, viscose or man-made fibres, including mixtures, can be used. The fabrics can be wool, yarn or piece-dyed.

Worsted spinning: High quality threads prepared from staple fibre. The origin of the textile fibre can be natural or synthetic. In the main, wools and wool mixtures are spun with polyester, polyacrylonitrile or other man-made fibres. The fibres are single or twisted during weaving or knitting to produce the fabrics. The cloth and knitwear is most widely used in women’s and men’s outer clothing.

Worsted spun: Of or pertaining to, materials produced by the worsted system of yarn spinning as distinct from materials made by woollen system of spinning.

Worsted system: A system of textile processing for manufacturing spun

yarns from staple fibres usually over 3 inches in length. The main operations are carding, combing, drafting, and spinning. There are three basic systems of worsted yarn spinning: the Bradford (or English system), the French (Alsatian or Continental system), and the American system.

Worsted yarn: Yarn spun from wool fibres which have been carded, and neither combed or gilled, or both.

Worsted-spun: Of, or pertaining to, materials produced by the worsted system of yarn spinning as distinct from materials made by the woollen system of spinning.

Wound dressings: The application of textiles to wound healing involves products for covering minor wounds, burns, ulcers and other deep skin wounds. Antimicrobial wound dressings manufactured by means of a bi-layer of silver-coated, high-density polyethylene mesh on a rayon adsorptive polyester core delivers nanocrystalline silver from a non-adhering, non-abrasive surface.

Wound (yarn) package: See **Package**.

Woven carpet: Carpets which are woven by machine or on hand looms (Machine-woven carpets).

Woven fabric: A structure produced when at least two sets of strands are interlaced, usually at right angles to each other, according to a predetermined pattern of interlacing, and such that at least one set is parallel to the axis along the lengthwise direction of the fabric.

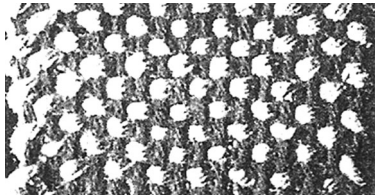

Woven interfacings: These are all grained, even if they are iron-on varieties, so they must be cut to the same grain as the garment section.

Woven-as-Drawn-In: Used often with weaving overshot patterns. This is the order of treadling that will give the finished fabric a squared pattern with a diagonal line running through it.

WP: Alpaca.

Wrap angle, in yarn friction testing: The cumulative angular contact of the test specimen against the friction inducing device, expressed in radians.

Closed faced fabric, I bonded, fused, laminated fabrics: The face or shell

fabric of closed construction so that no open face areas appear.

Wrap fibre: The so-called covering fibres of rotor-spun yarns which, among other things, improve the abrasion resistance during practical use. Research has shown that the total number of wrap fibres is smaller for a larger rotor and that coarser and longer fibres form approximately four times as many wrap fibres as finer and shorter fibres.

WRAP/FLA: US based certification programs in Social standards in Textiles and clothing.

Wrap-in, in vinyl coated glass yarn: A method of completing a package after break by wrapping the two ends together on the package without spicing or tying a knot.

Wrapper fibres: Fibres which wrap around the main body of a staple fibre yarn during yarn formation in the production of the open end and fascinated yarns.

Wrinkle: An unwanted crease, generally short and irregular in shape, on the fabric or garments.

Wrinkle: An undesirable crease in a fabric generally short and irregular in shape.

Wrinkle Mark: The marks formed on the garments during wearing.

Wrinkle recovery: That property of a fabric which enables it to resist the formation of wrinkles when subjected to a folding deformation.

Wrinkle resistance: That property of a fabric which enables it to resist the formation of wrinkles when subjected to a folding deformation.

Wrist, in anatomy: The joint which articulates between the end of the lower arm and the hand.

Wrist girth, in body measurements: The circumference over the prominence of the inner and outer forearm bones.

Wrong draft: See **Wrong draw**.

Wrong draw, in woven fabrics: One or more incorrectly drawn warp ends in the harness or reed. See also **Wrong draft, Misdraw**.

Wrong lift: An incorrect interlacing of warp and weft thread caused by a heald shaft or jacquard harness cord being in the incorrect position, as a result of the fault in the pattern chain, (pattern stitching) or faulty mechanical action (machine stitching).

Wrong pick: See **Mispick**.

Wrong side: See **Back side**. It is the side of the fabric that is unfinished and on the inside of the project.

Wronz: Wool Research Organization of New Zealand Inc., New Zealand. Textile research organization. Scope of activities: wool research (See **Wronz wool scouring process**), information service, commercial test projects, annual report and report series.

WRONZ wool scouring process: Process used to achieve slight destabilization of wool-fat emulsions: (a) Small wash trough with 1/3 of the usual bath capacity, vigorous bath circulation and mechanical movement of wool. The system includes the removal of flocks and solid particles, fat recovery and utilization of waste heat. (b) Breaking the emulsion using N-pentanol.

WS: Cashmere fibre.

WU: Guanaco fibre.

WV: Virgin wool.

Wuzzing: A way of removing excess moisture by centrifugal force. Hold onto the end of the skein firmly and spin it around like a helicopter blade.

w/v: Abbreviation for weight/volume Solutions are sometimes specified as being made as some percentage weight/volume. This means that the substance dissolved is measured by weight, and the final solution is measured by volume. For example, 5% sodium chloride w/v would mean that 5 grams of salt would be dissolved in enough water to make a total solution volume of 100 millilitres (or, say, 150g to make 3 litres, etc), and would be labeled "Sodium chloride 5% w/v". Solutions are most commonly made this way, and it can be assumed to be this way unless otherwise specified. Also see **w/v**.

w/w: Abbreviation for weight/weight solutions are sometimes specified as being made as some percentage weight/weight. Both the substance dissolved and the final solution are measured by weight. For example, a 10% solution of urea w/w would be made by dissolving one pound of urea in 9 pounds of water, and would be labeled "Urea 10% w/w". This method is sometimes preferred in industry since automatic mixing equipment is often designed to handle everything by weight rather than volume. Also see **w/v**.

WY: Abbreviation for Yak fibre (hair).

X

X: In the United States wool trade, denotes a full blood or high grade merino wool.

X (in colour chemistry): (a) One of the three CIE tristimulus values, the red primary; (b) Spectral colour-matching functions of the CIE standard observer used for calculating the X tristimulus value; (c) One of the CIE chromaticity coordinates calculated as the fraction of the sum of the three tristimulus values attributable to the X value.

Xanthate: A salt of xanthogenic acid. It is produced as a result of the effect of carbon disulphide on sodium alcoholate. See **Cellulose xanthate**.

Xanthating: Introduction of a xanthate group by chemical reaction. See **Xanthate**.

Xanthene dyes: Introduction of an oxygen bridge into the triphenylmethane dye molecule leads to the xanthene dyes. The colour is shifted from blue to red. The restricted rotation of the phenyl groups inhibits non-radiation de-excitation and gives rise to very strong fluorescence. See **Triphenylmethane dyes**.

Xenobiotic: A synthetic chemical foreign to that environment.

Xenon reference fabric: A dyed polyester fabric used for verifying xenon-arc equipment test chamber temperature conditions during a lightfastness test cycle.

Xenon-arc lamp: A type of light source used in fading lamps. It is an electric discharge in an atmosphere of xenon gas at a little below atmospheric pressure, contained in a quartz tube. See **Light fastness testing; Xenotest, Light Fastness Tester**.

Xenotest light fastness tester: It is an instrument for light fastness testing. The basis of these instruments, which can vary in size, is 1 or 3 vertically arranged xenon emitters surrounded by variable optic filter systems that allow the spectral distribution to be varied from "sunlight through a window" (light fastness) to "sunlight in the open air" (weather fastness). A high correlation to sunlight can be achieved. This means that the light fastness results achieved correspond closely with those that occur naturally. The advantage is that

the high level of radiation means that the test duration is shorter (ratio is approximately 1:9 for the central European climate).

Xerga: Spanish term for serge; twilled woollen blanket in Spain.

Xerogels: Gels that have lost their liquid as a result of vaporization, extraction by suction, etc., and are below their glass temperature state. They are not gels in the true sense (See **Lyogel**). Since they have the spatial structure of a polymer and are filled with air, they can be classified as (hard) foams. The best known xerogel is silica gel.

X-rays: X-rays consist of a bundle of rays (traveling at a speed of 300,000 km/s) produced on the same principle as cathode rays (and reflected by the anode opposite the cathode) that can penetrate substances and enable their structure to be detected. They are stopped to a greater or lesser degree by solid substances (e.g., metals), broken down into a clearly defined line spectrum by crystals. The wavelength or oscillation count for each atom is characteristic (in direct ratio to the atomic charge and number).

XX soft: (a) English mill term for very soft and yielding folded thread, the single yarn containing about twice as many twists as the doubled; (b) In the United States, wool trade denotes full blood merino wool.

XXX: In the United States it denotes the wool from a cross between a Saxony and common merino.

Xylodine: Name given to a paper yarn made by twisting and coating with glue and fibre a strip of paper.

Xylolin: (a) Plain woven fabric made of cotton warp and paper yarn filling. Used for cheap working clothes; (b) Paper yarn made in Germany and Austria. It is used for carpets and backings for carpets.

XYZ colour measurement system: See **Colourimetric measures; Colourimetry; Chromaticity diagram.**

Y

Y (in colour chemistry): (a) One of the three CIE tristimulus values, equal to the luminous reflectance or transmittance, the green primary; (b) Spectral colour matching function of the CIE standard observer used for calculating Y tristimulus value; (c) One of the CIE chromaticity coordinates calculated as the fraction of the sum of the three tristimulus values, attributable to the Y value.

Yachan: Silky seed fibre of the *chorisia insignis*, used for stuffing.

Yacht cloth: Piece dyed fine flannel of a serge weave with a rough finish; used for clothing.

Yak: Hairs that are categorized as fibres of animal origin from the Tibetan yak. These are the long hairs on the belly and tail.

Yama-Mai silk: A species of wild silk yielded by the *Antheraea*, the Tussah spider in Japan and China which is extremely similar to real silk in lustre and fineness. It is regular, and is white, yellowish or greenish in colour.

Yard (yd): English unit of length; 1 yd = 0.9144 m; 1 m = 1.0940 yd.

Yard goods: Fabric sold on a retail basis by the running yard.

Yardage: The amount or length of a fabric expressed in yards.

Yarkand: Large and heavy rugs made in Central Asia with cotton web and long, loose, wool pile tied in Senna knot. The Chinese influence is very much marked in the design, consisting of dragons, fret pattern, fish, or other animals, mostly in bright yellows, pinks, reds, blues, greens, etc.

Yarn: A generic term for a continuous strand of textile fibres, filaments, or material in a form suitable for knitting, weaving, or otherwise intertwining to form a textile fabric. Yarn occurs in the following forms:

- (a) A number of fibres twisted together;
- (b) A number of filaments laid together without twist (zero twist yarn);
- (c) A number of filaments laid together with more or less twist;
- (d) A single filament with or without twist (a monofilament);
- (e) One or more strips made by a lengthwise division of a sheet of material such as a natural or synthetic polymer, a paper or a metal foil used with or without twist in a textile construction.

A textile product of substantial length and relatively small cross-section that consists of fibres or filament(s) (or both) with or without twist:

- i. Assemblies of fibres or filaments are usually given other names during the stages that lead to the production of yarn, e.g. tow, slubbing, sliver, roving (q.v.). Except in the case of continuous-filament fibres or tape yarns, any tensile strength possessed by assemblies at these stages would generally be the minimum that would hold them together during processing;
- ii. Staple, continuous-filament and monofilament yarns are included;
- iii. No distinction is made between single and cabled yarns;
- iv. Zero-twist and self-twist staple yarns are included;
- v. Zero-twist continuous-filament yarns are included.
- vi. By the definition of fibre and filament, paper, metal-film and glass yarns are included.

Yarn (boucle or loop): Boucle or loop yarns are compound yarns made by aspecial folding process which results in wavy or looped projections. Fabrics will have a more or less grainy handle and a textured surface. Examples: Boucle', Frise', Frotte'.

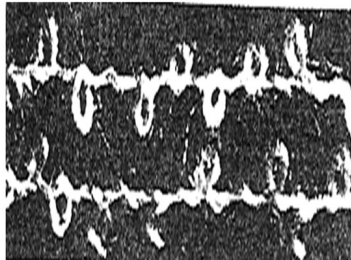

Yarns (bourette or knop): Bourette or knop yarns are folded yarns containing short, often coloured bunches of fibres or yarn at regular or irregular intervals. The knops may be formed during spinning or during folding. Fabrics will have a structured appearance. Fabric example, Donega Tweed.



Yarn (chenille): It is a cut pile yarn; it is soft and voluminous. These yarns are made by cutting special fabrics into strips. They are used in furnishing fabrics and knitwear.

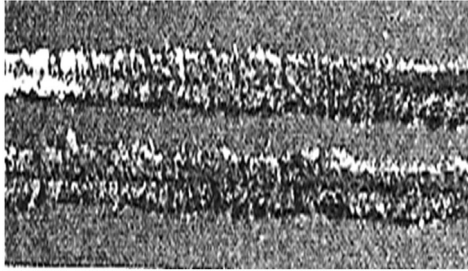

Yarn (crepe’): Crepe yarns are used to make fabrics with a wrinkled surface and a sandy handle. They are made from highly twisted yarns. Fabric examples, crepe’ de chine, georgette, crepon, marocain.

Yarn (Jaspe or mouline’): These yarns are made by folding two or more differently coloured yarns made from different fibres with different dyeing behaviour. They give mottled appearance. Fabric example: Fresco.

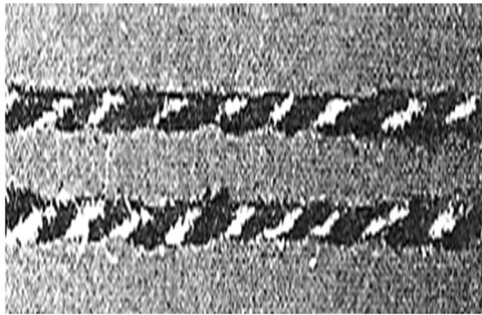

Yarn (mixture or ingrain): They are made by mixing fibres of different colours during spinning. This results in heather effect. Fabric example: Marengo.

Yarn (mélange or vigourex): Melange or vigourex yarns are spun from combed sliver or top which has been printed with stripes. The appearance is somewhat like mixture. These are also produced by mixing dyed and undyed loose fibres also.

Yarn (Mottle or Marl): These are made by spinning from two-colour roving or from two roving of different colours. The appearance is like mouline, but with less sharp contrast.

Yarn (slub): Slub yarns are single or folded yarns having long thick places, regularly or irregularly disposed. The slub effect is made either in spinning or in folding. Fabric may have the character of linen or wild silk, which is favoured in furnishings.

Yarn appearance: The visual effect obtained by viewing a sample of yarn wound with a designated traverse on a blackboard of designated size. Descriptive terms for yarn appearance are

- (a) single yarn –one yarn that contrasts with adjacent yarns;
- (b) multiple yarns –two or more yarns that contrast with adjacent yarns;
- (c) lean yarn – a yarn having a smaller diameter than the normal population;
- (d) bulky yarn –a yarn having a greater diameter than the normal population;
- (e) light yarn –a yarn that appears to be lighter than the normal population;
- (f) dark yarn –a yarn that appears to be darker than the normal population;
- (g) intermittent yarn –a yarn that is non-uniform in colour intensity along its length, appearing as light and dark sequences.

Yarn break(in sewn seams): A mode of failure evidenced by yarns rupturing at the seam or at any other area in the test specimen.

Yarn carriers: This can mean: (a) Perforated inserts on which the yarn is wound; (b) Spindles or perforated tubes onto which the yarn packages are put so that the liquor can flow through them; (c) Moveable material carriers that can be inserted into the dyeing machine, with a hollow base into which the spindles or dyeing tubes can be inserted.

Yarn clearer: A device designed to cut or break when it detects changes in mass or diameter which exceed set limits. Yarn clearers are normally part of, or an addition to, a winding machine.

Yarn composites: Flexible and porous fabrics (bonded fabrics) made from threads or thread layers and bonded by sewing, glueing, plasticizing, fibre bonding, or combinations of these techniques.

Yarn construction: A term used to indicate the number of single yarns and the number of strands combined to form each successive unit of a plied yarn or cord.

Yarn construction number (for asbestoes): A system designed to show the construction namely, the cut of the single yarn, the number of plies and whether reinforcements are present.

Yarn count: Deprecated term, used as specific yarn numbering system. See **Linear density of fibres and yarns**.

Yarn delivery (in knitting machine): Yarn tension presented to a needle hook that has to be uniform, constant and as low as possible, in order to get uniform, good fabric appearance and also to prevent yarn breaks. Therefore, several different types of yarn delivery devices are used. These devices are divided into two main groups, those for constant yarn consumption per unit time on given feeders (positive feeding, yarn metering) and those for variable yarn consumption per unit time on a feeder (negative feeding, yarn storage). The first one is used for simple fabric designs with no large pattern repeat area. The second one is used for jacquard designs that have a large pattern area and most of the feeders have varying yarn consumptions per unit time.

Yarn distortion (in woven fabrics): A condition in which the symmetrical surface appearance of a fabric is altered by the shifting or sliding of warp or filling yarns.

Yarn driers (air stream): This type of dryer is used for drying yarn packages (on perforated inserts) in columns on spindles or perforated tubes as a discontinuous process. If yarn packages with a large quantity of wound yarn are used in the compression column dyeing process, the yarn packages have a high level of flow resistance, and for this reason they are dried using a high frequency dryer after continuous centrifugal drying.

Yarn dyed: Dyed in yarn make-up, e.g. in hank form (dyeing of yarn in hank form), as a yarn package, or spool, and in continuous form.

Yarn dyed fabrics: Fabrics, the yarn of which was dyed before woven.

Yarn dyeing differences: Variations in take-up of dyes by yarns, resulting in streaks in finished fabrics.

Yarn feeding position (in knitting): A new yarn is fed into the needle hook by a yarn feeder, while the needle is moved downwards by following the cam track. Holding down-knocking over sinker begins moving away from the machine centre. The old loop starts to close the latch of needle (castoff) by moving upwards.

Yarn finish: Cotton or linen sewing thread is soaked in starch and wax or paraffin, dried, stretched (lusted) and brushed to give it a smooth surface. See **Glossing; Lustring**.

Yarn fleck: A mixture of yarn of spotted and short streaky appearance due to the introduction of a minority of fibres of different colour and/or lustre.

Yarn humidifying agent: These are used for humidifying yarns, to set the required humidity level and maintain it during the course of subsequent

textile finishing processes as well as to cause an increase in strength or shape retention. Stabilized wetting agent solutions with added preservatives, bactericides or anti-fungal products are usually used.

Yarn intermediates: A generic term for products obtained during the conversion of fibres to yarns, including card webs, laps, slivers, roving, tops, etc.

Yarn number: The value, actual or nominal, or a yarn in a specific yarn numbering system. A measure of the fineness or size of a yarn expressed either as 'mass per unit length' or 'length per unit mass' depending on the yarn numbering system. Yarn number is an indirect system and are frequently termed yarn counts. For example, No. 20 – cotton count, No. 45 –worsted count. Direct yarn number (equal to linear density) is the mass per unit length of the yarn which is equal to the mass of yarn specimen divided by length of the yarn specimen. Indirect yarn number (equal to the reciprocal of linear density) is the length per unit mass of yarn. Indirect yarn number equals to the length of yarn specimen divided by mass of yarn.

Yarn number (equivalent single): The yarn number based on the observed mass per unit length of plied yarn, a cabled yarn or a yarn whose number has been changed by processing, such as twisting or bulking.

Yarn numbering system: A system for expressing yarn fineness or size as a relationship between length and mass. Two systems are in use –

(a) Direct yarn numbering system: It expresses yarn number in terms of mass per unit length (linear density). Examples of direct yarn numbering system are

- (i) *Denier* – Number of grams per 9000 m
- (ii) *Grex* – Number of grams per 10000 m (obsolete)
- (iii) *Spindle number* – Number of ponds per spindle or 14400 yds. (13167 m) length, expressed as pounds per spindle
- (iv) *tex* – The number of grams per 1000 m.

(b) Indirect systems: Expresses yarn number in terms of length per unit mass (reciprocal of linear density). Examples are

- (i) *Count, cotton*– The number of 840 yards length per pound; generally used for yarns spun on the cotton system.
- (ii) *Count, metric* – The number of metres per 100 gram.
- (iii) *Count, worsted*– The number of 560-yard length per pound; Generally used for yarns spun on the worsted system.
- (iv) *Cut* – (a) For asbestos, glass: The number of 100 yards lengths per pound; (b) Wool: The number of 300 yards length per pound.

- (v) *Hank* – A synonym for the indirect yarn number (count) of slubbing or roving.
- (vi) *Lea* (linen) – The number of 300 yds. length per pound.
- (vii) *Run* – The number of 1600 yard lengths per pound, generally used for yarn spun on the woollen system.
- (viii) The number of 1000 yard lengths per pound (obsolete).

Yarn number (in jute): Mass per unit length of a yarn measured as the number of pounds per 13,167 m (14,400 yd.) and expressed as pound per spindle.

Yarn number(resultant): See **Yarn number (equivalent single)**.

Yarn package: A length or parallel lengths of yarn suitable for handling, storing, or shipping.

Yarn quality: Various grades of yarn designated by the producer with respect to performance characteristics, e.g., first quality, second quality, etc.

Yarn severance: A numerical value expressed on a percentage basis from a test that is used as an index of the degree of cutting of fabric yarns by the sewing machine needle in making sewn seams.

Yarn slippage (in sewn seams in sewn fabrics): The displacement of one or more yarns from the original position, causing differences in alignment, spacing or both.

Yarn take-up (in fabric): The additional length of yarn used to make a given length of fabric.

Yarn (asbestos): A twisted assemblage of (a) asbestos fibre, (b) asbestos and other fibres, (c) asbestos and other fibres with an insert of cotton or other yarn reinforcement.

Yarn, backing (in pile fabrics): The base yarn that holds the pile in place, formed by the stuffer yarn and the warp and weft of the fabric. See **Backing yarn**.

Yarn (blended): A single yarn spun from a blend mixture of different fibre species. See **Blended yarn**.

Yarn (bulk): See **Bulk yarn**.

Yarn (bulked): Same as *bulk yarn*, *Yarn*, *bulk*. They are texturized yarn which is voluminous with crimps and loops having normal extensibility and elasticity. The term bulked yarn is often used generally to cover all continuous filament textured yarns and bulked staple fibre yarns.

Yarn (cabled): A yarn formed by twisting together two or more plied yarns. The individual plied yarns have the same nominal length and tension.

- (a) Combinations of folded yarns and single yarns may be described as cabled yarns, e.g., a single yarn is twisted together with two-folded yarns to give softness to the resulting yarn.
- (b) In the tyre-yarn and cord sections of the textile industry, cabled yarns are termed “cable cords” or “cords”. These terms include two-fold continuous-filament man-made fibre yarns, a traditional example being 1,830 dtex rayon cord, single twist 480 t/m (Z), and cabled twist 480 t/m (S).
- (c) For terms concerning twist designation in cabled yarns, See twist (b). See **Cabled yarn**.

Yarn (carded): Yarns made from fibres that have been carded but not combed in the manufacturing process. See **Carded yarn**.

Yarn (chenille): A type of fancy yarn consisting of a cut pile which may be of one or more of a variety of fibres, helically disposed around axial threads which secure it. Chenille yarns are usually used in the manufacture of furnishing fabrics and other broad and narrow fabrics.

Yarn (cloud): A type of fancy yarn made by using two threads of different colours in such a manner that each thread alternately forms the base and cover to ‘cloud’ the opposing thread. It is made by alternate fast and slow deliveries from two pairs of rollers.

Yarn, cockled: See **Cockled yarn**.

Yarn, combed: Yarn made from fibres that have been carded and combed in the manufacturing process. See **Combed yarn**.

Yarn, combination: A ply yarn twisted from single yarns of different fibres, for e.g. silk and rayon, rayon and acetate, etc. See **Combination yarn**.

Yarn, craft: See **Craft yarn**.

Yarn, doubled: See **Yarn folded**.

Yarn, eccentric: A fancy yarn; an undulating gimp yarn.

Yarn, elastomeric: A non-textured yarn which can be stretched repeatedly at room temperature to at least twice its original length and which after removal of the tensile force will immediately and forcibly return to approximately its original length. See **Elastomeric yarn**.

Yarn, fancy: A compound yarn comprising of a twisted core with an effect yarn wrapped around it so as to produce a wavy projections on its surface. In single yarn, the irregularities may be due to the inclusion of knots, loops, curls, slubs, etc. In plied yarns, the irregularities may be due to variable delivery

of one of its components or to twisting together dissimilar single yarns. See **Fancy yarn**, **Boucle' yarn**.

Yarn, filament: A yarn composed of filaments assembled with or without twist. See **Filament yarn**.

Yarn, filler: See **Stiffer yarn**.

Yarn, filling: A yarn intended for the use in the weft (filling). See **Filling yarn**.

Yarn, flat: (a) A multifilament yarn with no twist. The term is still used in respect of these yarn after a small amount of twist has been introduced by subsequent processing, e.g. Add-in over-end winding; (b) A synonym for straw yarn.

Yarn, gimp: A compound fancy yarn comprising a twisted core with an effect yarn wrapped around it so as to produce wavy projections on its surface.

Yarn, high bulk: See **Bulk yarn**.

Yarn, high bulked: Man made staple fibres can also be made into bulky, voluminous yarns. Such high-bulk yarns are usually made by blending acrylic fibres of high and low potential shrinkage. During a subsequent heat treatment, the high-shrinkage fibres contract causing the other fibres to buckle. A similar effect can be obtained by using bicomponent fibres. See **Yarn high bulk**; **Bulk yarn**.

Yarn, industrial: A yarn composed of continuous filament usually of high breakage tenacity, produced without or with twist and intended for application in which functional properties are of primary importance. For e.g., in reinforcing material in elastomeric products (tyres, hose, belting) to protective covering, etc. See **Industrial yarn**.

Yarn, knicker bocker (or knop yarn or nepp yarn or knicker yarn): A fancy yarn. A yarn made on the woollen system and showing strongly contrasting spots on its surface that are made either by dropping in small balls of at the latter part of the carding process or by incorporating them in the blend and so getting the carding machine that these small lumps are not carded out.

Yarn, kraft: A yarn made by twisting a strip of paper manufactured from the wood pulp by the sulphate process.

Yarn, loop: A compound yarn comprising of twisted core with an effect yarn wrapped around it so as to produce wavy projection on its surface.

Yarn, mercerized: A cotton yarn, which has been treated with a solution of caustic soda under condition of caustic concentration and temperature which effect a permanent or irreversible swelling effect on cellulose. Commercially

caustic treatment is supplemented by the application of tension. See **Mercerised yarn**.

Yarn, mock chenille: A double corkscrew yarn.

Yarn, non-torque: See **Bulk yarn**.

Yarn, plied: A yarn formed by twisting together two or more single yarns in one operation.

Yarn, self-blended: A single yarn spun from a blend or mixture of the same fibre species.

Yarn, shotting: A single filling yarn used in weaving gunny sacking.

Yarn, silk: (a) Grenadine – A yarn composed of more than one strand with the twist in the plied yarn in the opposite direction from the twist in the individual components, each twist having a minimum of approximately the following number of turns per inch depending on the number of strands used

Strands	Minimum no. of turns
2 (13 to 15 Denier or equivalent)	32
3	30
4	28

(b) Organzine – Two or raw silk strains twisted in the singles, doubled and twisted in the opposite direction in the ply. Turns per inch in the singles and ply usually within the limits of 10–20 turns generally used as warp; (c) Tram – Raw silk yarns doubled and twisted with a low number of turns per inch and generally used as weft.

Yarn, single: The simplest strand of textile material suitable for operations such as weaving knitting, etc. See **Single yarn**.

Yarn, slub: A yarn in which slubs may be deliberately created to produce a desired effect.

Yarn, snarl: A compound yarn in which snarls or kinks are projecting from the core.

Yarn, spiral: A plied yarn displaying a characteristic smooth spiralling of one component around the other.

Yarn, spun: See **Spun yarn**.

Yarn, stabilized: It is a textured yarn which have been given additional setting treatment to reduce their elasticity and crimp extension.

Yarn, staple glass: See **Staple glass yarn**.

Yarn, stretch: Yarns produced by texturing filament yarns which are highly elastic with crimp extension up to 150–300%. See **Stretch yarn**.

Yarn, stripe: A yarn that contains elongated knops.

Yarn, stuffer: See **Stuffer yarn**.

Yarn, textured: See **Textured yarn**.

Yarn, torque: See **Bulk yarn**.

Yarn, union: A yarn made by twisting together yarns of different fibres.

Yarn, warp: A yarn intended for use or used in the warp of a woven fabric.

Yarn, warp knitting: A yarn intended for use or used in the making of a warp knit fabric.

Yarn, woollen: A yarn spun from wool fibres which has been carded but not combed or gilled. See **Woollen yarn**.

Yarn, worsted: A yarn spun from wool fibres which have been carded and either gilled or combed or both. See **Worsted yarn**.

Yarn, zephyr: A variety of soft worsted yarn characterised by a low twist and spun from wool which is fine or finer in average diameter than United States standard 64s grade tops. See **Zephyr yarn**.

Yarn, zero twist: (a) A continuous filament yarn in which there is no twist; (b) A multi-folded yarn in which there is no folding twist.

Yarn, doubled (folded yarn, plied yarn, doubled yarn): A yarn in which two or more single yarns are twisted together in one operation, e.g. two-fold yarn, three-fold yarn, etc.

Note: In few sections of the textile industry, e.g. the marketing of hand-knitting yarns, these yarns would be referred to as “two-ply”, “three-ply”, etc.

Yarn finishing: Cotton or linen sewing thread is soaked in starch and wax or paraffin, dried, stretched (lusted) and brushed to give it a smooth surface. See **Glossing; Lustring**.

Yarn mercerizing: Yarns are mercerized continuously in hank form or as a continuous run of yarn. For yarns in hank form, the following method is still in use in a few cases – yarn is soaked in caustic soda solution 25–50 °Bé (at 10–20°C), it is squeezed off and tensioned to the original length. Washing takes place under tension.

Yarn number: A measure of the fineness or size of a yarn expressed as mass per unit length or length per unit mass, depending on the yarn numbering system.

Yarn number, jute: Mass per unit length of a yarn measured as the number of pounds per 13,167m (14,400 yd), and expressed as pounds per spindle.

Yarn numbering system: A system expressing yarn size as a relationship between length and mass. There are two types yarn numbering systems – (a) Direct numbering system in which number of mass per unit length is expressed as the number; (b) Indirect numbering system where number of length units per unit of mass are expressed as the number.

Yarn package: (1) Piece make-up – Piece goods wound onto a yarn package carrier (batching roller); (2) Yarn make-up – Package where the support (spindle or insert) is removed when the process is finished, a yarn spool or winding structure without an insert. Other winding forms for commercial purposes are clews or skeins (for crochet, knitting and embroidery yarns), reels (for sewing silk) and other winding structure for wide-wound yarns.

Yarn package (in dyeing): When dyeing yarn on packages, the type and quality of winding, but also the package and insert system, have a particular influence on the quality of dyeing. Conical yarn inserts continue to be used widely even though they have few disadvantages in comparison with modern cylindrical insert systems – uneven package flow, insert/spacer leaking, low batch weight, unfavourable liquor ratio, high personnel costs for loading and unloading the carrier, unsuitable environment for using robots for loading and unloading.

Yarn package (preparation of): Automatic yarn package winding takes on an important function in the textile production process. A package must be properly wound in order to be suitable for productivity in subsequent stages, whether for twisting, warping, weaving or knitting. “Quality packages” reduce the frequency of out-time and avoid errors.

Yarn package (winding machine): A machine used for winding yarn on to the dyeing tubes. The essential purpose of a yarn package winding machine is to ensure that the yarn package is calibrated from the point of view of density, shape and weight, as well as to the machines and processes for the subsequent finishing phases, so that production is guaranteed. Perforated dye tubes are used as a yarn carrier, usually made of plastic, either disposable or re-usable, and either conical or cylindrical in shape (on axially flexible inserts). There are two different winding methods, random winding and precision winding; it can be done by precision winding or random winding, former being most widely used.

Yarn printing: Yarn printing is done to cause certain fuzzy coloured patterns after weaving, knitting or tufting. For this technique, yarns are printed either in hank form (single shade/pearl printing, or multi-colour/ombré printing), or in warp form (warp printing) or in knitted form (space dyeing).

Yarn printing machine: Parallel winched hanks are printed under tension with relief print rollers (Hank yarn printing machine).

Yarn raising: A yarn raising machine is suitable for raising yarns for hand and machine knitting in the range Nm 20 and coarser. The raising process is carried out by raising rollers on individual threads.

Yarn singeing: In order to remove the hairiness of the yarn and improve the shining of the same, yarn singeing is done. The yarn is passed through a gas flame at high speed where the protruding fibres are burned off.

Yarn singeing machine: See **Gassing machines**.

Yarn slippage(in sewn fabrics): The displacement of one or more yarns from the original position(s) so as to cause differences in alignment, spacing, or both in one or more fabric yarns.

Yarn steamer: See **Batch steamers**.

Yarn steaming: In a free state, the yarn has the tendency to untwist or to form loops and snarls. Cross-wound yarn packages which are processed as weft yarn therefore need to be fixed well. Vapour penetration of wound yarn packages, type of steam, temperature accuracy and reproducibility of programmes have all become more significant in yarn steaming. Yarn fixation is generally carried out in pressure steam chambers with vacuum and excess pressure ranges. The steam is supplied either directly from the steam network or indirectly via an integrated water bath.

Yarn Tensioner: In winding staple yarns, sufficient yarn tension is used to cause breaks in thin places while the yarn is being wound. This permits the thin places to be cut out, the yarn to be repaired and winding to continue. Variations in running tension alter the level at which the thin places are removed and so affect the yarn regularity of the final product. Here the yarn tensioner is used to take care of the yarn winding regularity. There are various forms of tensioner, the simplest of which works by merely deflecting yarn around fixed posts. This is called capstan.

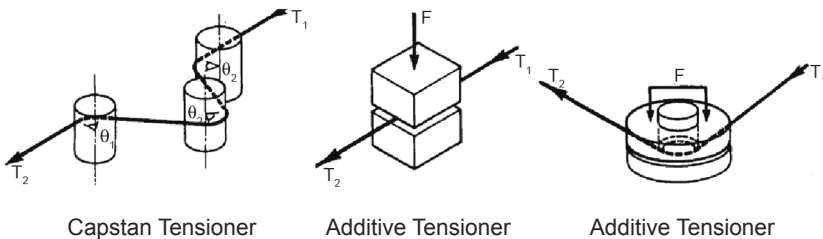

Tensioner. Another tensioner is uses a deadweight or spring to give a fixed increment of tension. This type is Tensioner is called additive tensioner. There is also a system in which both these principles are used and it is called a combined tensioner.

Yarn twist: See **Twist of spun yarns.**

Yarn-to-cord conversion efficiency: In tire cord, this is a measurement relating tensile strength of untwisted yarn to tensile strength of cord. Increasing cord twist or increasing yarn diameter lowers conversion efficiency.

Yaws: Flaws in cloth, consisting of thin places.

Yaxci: Very soft, flexible and lustrous sisal hemp from Yucatan.

Yearling: (1)Wool obtained at the second year's shearing.

(2) A sheep or goat that is 12–18 months of age.

Yellow (in colour theory): One of the process ink colours for printing. Pure yellow is the “blueless” colour; it absorbs all wavelengths of blue from light and reflects all red and green wavelengths.

Yellow weed: A mordant dye. See **Natural dyes.**

Yellowing: The propensity of heavily dressed bleached goods to turn yellow as the result of disintegration of the bleaching chemicals.

Yellowing of DP finishes: Yellowing of DP finished fabrics can be caused by a number of conditions. For example, excessive curing temperatures and/or excessive catalyst will scorch cellulosic fabrics. Few reactants have colour bodies which cause yellowing. Usually nitrogenous compounds discolour with heat. Buffers are often added to commercial finishes to combat yellowing problems.

Yellowing of wool: When wool is exposed to radiation from the sun (or similar light sources in the spectrum), two apparently opposite processes can be observed – wavelengths of between approximately 280–400 nm result in yellowing and fibre degradation, whereby the short-wave, higher-energy portion of 280–330 nm (blocked by window glass) has a significantly more damaging effect than the range of approximately 330–400 nm.

Yellowing on storage: In the wide majority of cases of white goods yellowing on storage, three yellow components were found. These yellow components occurred individually, but also in varying blending ratios. These yellow components have been identified as one nitrophenol derivative and two quinone compounds. This yellow body forms easily due to the effect of nitrogen oxides on the sterically hindered phenol 2,6 di-tert. butyl-4-nitrophenol. The formation of compound I is also possible if there is a substituent in opposition, however.

Yield: (1) Number of linear or square yards of fabric per pound of fibre or yarn; (2) The number of finished square yards per pound of greige fabric.

Yield: (1) Wool designated commercial composition obtained by processing a lot of raw wool, expressed as a percentage of the raw wool.

(2) The amount of fabric delivered off a knitting machine in terms of its weight per unit length or area, or the number of linear units delivered per unit weight. For example, ounces per yard² or ounces per square yard or yards per pound.

Yield (of wool): The percentage of a designated commercial composition obtained by processing a lot of raw wool.

Yield strength: The stress at which a material exhibits a specified limiting deviation from the proportionality of stress to strain.

Yield (in raw wool): The combined weight of clean wool fibre present and vegetable matter present as a percentage of the raw wool weight.

Yield, finished (in knitted fabrics): The number of finished square yards per pound (square metres per kilogram) of finished fabric. See **Finished yield (in knitted fabrics); Yield (in knitted fabrics)**.

Yield, greige (in knitted fabrics): The number of finished square yards per pound (sq. m. per kg) of greige fabric. See Greige yield (in knitted fabrics).

Yield point: The point on the load-elongation, or stress strain curve, at which load, or stress, ceases to be linearly proportional to the elongation, or strain; that is, the point beyond which the work is not completely recoverable and permanent deformation takes place.

Yield point (in stress-strain curve): The point beyond which work is not completely recoverable and permanent deformation takes place.

Yerges: Thick, coarse, felted woollen fabric, used for horse blankets.

Yerli: Fine staple wool yielded by the sheep near Smyrna, called kivirdjik, having small horns and a narrow tail. Used for carpets, cloth, blankets, etc.

Yesteklik: Turkish name for small mats, having a soft pile and used for pillows; also called Anatolian mats.

Yolk: The natural grease and suit covering on the wool fibres of the non-scoured fleece, and excreted from glands in the sheep's skin. Usually the finer the wool, the more abundant the yolk. Yolk serves to prevent entanglement of the wool fibres and damage during growth of the fleece.

Yoke (self): The entire back of a garment is one piece and has a single yoke superimposed on the outside.

Yoke (two-pierce): Two identical pieces of fabric are joined to a shortened back piece to produce the total back.

Yokeless shirt: The front and backs of a shirt are joined without a yoke facing.

Yoke (variations of): Three variations of yokes are as follows –

- (a) Shoulder yokes
- (b) Waist yokes
- (c) Hip yokes

Yoke (square): The bodice is split into two, straight across the back or front of a garment using a variety of proportions. It allows contrasting fabrics and other methods of creative construction to be used.

Yoke (cape or storm flap): The top part of this construction echoes the shape underneath, but flare is added to create the cape effect. This part is then laid over the original shape. The storm flap has less flare and simply provides an extra layer of protection during poor weather – found on rainwear and protective garments.

Yoke (tucked): As the square yoke, but a pleat or tuck has been added horizontally and top stitched down.

Yoke with pocket: This pocket is like the epaulette pocket. It is set into the yoke seam.

Yokohama: Crepe that is very fine, close woven crepe, for coats, etc., not transparent.

Yomud: Rugs made of wool and goat hair in Turkestan with medium long and close pile. The design consists of diamonds with angular hooks around the edge in the centre and trailing, angular vine or stripes in the borders. The colours are blues, warm reds, greens, etc.

Youghal lace: The best among the Irish point lace. See **Irish point**.

Young's modulus (in the stress strain curve for an elastic material): The ratio of change in stress to change the strain within the elastic region of the material.

Young's modulus: This is used to characterise the elasticity of fibres. Gradient of the tangents on the stress-strain curve through its origin (approximately elasticity modulus).

Ypres: (1) Fine medieval worsted from flanders; (2) Bobbin lace similar to the Valenciennes (see), having a square mesh ground, the threads being twisted four times around each other.

Yucca fibres: Similar to Sisal, a leaf bast fibre which is obtained from the 25–60 cm long leaves of the yucca plant (*yucca filamentosa* L.) e.g. from the native family Liliaceae of Southern North America. They are harvested twice a year. Fibres are developed either chemically (lime preparation) or by boiling under pressure, which releases lignin from the yucca fibre to a large extent. Short elementary fibres (approximately 1.3–1.5 mm), breaking length 40–67 cN/tex.

Uses: For twine, agricultural twine, also for carpet fabrics, tarpaulins, etc.

Yuenchingwacheinyong: Chinese figured velvet.

Yuruk: Rugs; small and very durable rugs made by the nomad Yuruks in Asia Minor of goat's hair or dark wool. The long wool pile is tied in Ghiordes knot. The design is composed of very large but simple geometrical devices of brilliant colours over a dark brown field. They are finished with a selvage all around and the ends have a short fringe or braid.

Yutun: Wool camlet made in China in all widths, used by natives for winter clothing. The warp is of silk and the filling of wool.

Yuzen printing (Ju-Sen printing): Artisanal printing process practiced in Japan. A forerunner to modern screen printing. Named after its inventor, the artist Yuzensai Miyasaki (1654–1736). Papery sheets are produced from the bast of the mulberry tree by pasting together several layers, these are stiffened and then made watertight with oil. The screens are manufactured from these by cutting out the motives. Print paste is applied in various ways e.g., hair brush, besom, doctor blade and spray nozzles on paper funnels. This method is used to produce high-quality prints on kimono materials. Depending on the process technique used, direct print or resist effects are obtained.

Z

Z (in colour chemistry): (a) One of the three CIE tristimulus values; the blue primary; (b) Spectral colour-matching function of the CIE standard observer used for calculating the Z tristimulus value; (c) One of the CIE chromaticity coordinates calculated as the fraction of the sum of the three tristimulus values attributable to the Z primary.

Z Twist: See **Twist**.

Zacate: Mexican name for various species of fibrous grasses; used for making mats and ropes.

Zackel: Coarse and long carpet wool, yielded by the Hungarian sheep.

Zafiri: Raw cotton of brown staple, grown in Egypt.

Zanella: Smooth and highly lustrous, atlas construction lining fabric (cotton and also cotton warp +worsted yarn weft = wool/cotton union-Zanella).

Zanella: Serge, made with cotton warp and worsted filling; used for making lining and umbrella covers.

Zanzibar cloth: Grey cotton goods, made in India.

Zappara: In Southern Europe, the agave fibre which is used in braids, horse blankets, etc.

Zapupe: A white, strong, glossy, soft and pliable fibre yielded by a species of the agave in Mexico. It is used for making ropes and coarse fabrics.

Zararas: Ordinary cotton prints in Latin American countries.

Zardozi: Old Indian gold embroidery (silk yarn wrapped with metal foil) on heavyweight fabrics.

Zarts solution: Dyestuff mixture for differentiating between cupro (violet/blue colouration) and viscose fibres (= pink/red colouration) in fibre blends. Reliable method of differentiation.

Zaza printing method: Yarn sheet printing process (similar to the vigoureux printing process) in which yarn sheets run between a relief and a felt roller which is supplied with printing paste from the printing paste trough via a rubber roller, printing paste being transferred to the yarn material in raised places of the relief through felt roller contact pressure. Five shades can be produced with one ground colour and four pairs of rollers.

ZE: Abbreviation of Zein fibre.

Zegna sports' iJacket: Ermenegildo Zegna is a worldwide brand. Zegna Sports has produced the iJacket, which has become a prominent Italian product for men. It is compatible with the Apple iPod. During routine chores or exercise such as hiking, the user is able to access the music player through a fabric keypad. This product also uses Elek Tex's interface with Bluetooth so there is no need to reach for one's mobile phone. The fabric keypad on the outside of the jacket can be used to answer or hang up a call. Because this product has characters that are comfortable to wear, and functions of music player and cell phone, we expect positive reactions from consumers.

Zein fibre: Man-made protein fibres from the zein contained in maize meal. Spun by the wet spinning process (precipitating bath: dilute sulphuric acid, acetic acid and zinc sulphate). Dry strength 11 cN/tex at 40% elongation. Used in a blend with cellulosic and other fibres (increases elasticity, improves crease resistance) for warp and weft knitted fabrics and woven pile fabrics.

Zeolite: A member of a group of hydrated aluminosilicate minerals which occur in nature and are also manufactured for their ion-exchange and selective-absorption properties. They are used for water softening and for sugar refining. The zeolites have an open crystal structure and can be used as molecular sieves. See also **Ion exchange**; **Molecular sieve**.

Zephyr: Originally, a good quality light-weight worsted yarn, but now refers to fine and soft sheer gingham type cottons. Also called *Zephyr gingham*. See **Gingham**.

Zephyr: Plainweave, very soft, lightweight, sheer fine, woollen flannel, mixed with silk. Often colour woven with stripes on white ground.

Zephyr gingham: Fine soft gingham, finished without dressing.

Zephyr yarn: Soft spun worsted yarn, made of soft merino wool with three or more strands; used for embroidery. A variety of soft worsted yarn characterised by a low twist and spun from wool which is as fine or finer in average diameter than 64's grade tops.

Zerbase: Persian double-faced silk fabric interwoven with gold or silver threads.

Zero discharge layout: Design of an industrial plant to release no effluent, whether cooling water (by closed recirculation system) or industrial effluent.

Zero-moisture: See **Moisture-free (the preferred term)**.

Zero-twist: Twist-less, devoid of twist.

Zibeline: A heavy coating fabric with a long, shaggy nap laid in one direction. Usually woollen, but there may be other fibres such as acrylic included. Strong colours are normally used and the cloth is often striped. Made with heavy coarse yarns which can be woollen or blended with mohair. This fabric is often woven as a double cloth so as to obtain added weight, warmth and durability. Used for women's coats, capes, children's coats. Also called Zibeline.

Zig-zag stitch: It is a utility stitch on a sewing machine which allows seams to stretch. It may also be used on the raw edge of fabric to prevent fraying.

Zig-zag twill: A twill weave, producing a zig-zag effect.

Zig-zagged seam-finish: A finish for the raw edges of the seam allowances of a plain seam, in which machine zig-zag stitching is placed 3 to 6 mm (1/8 to 1/4 in) from the raw edge.

Zimmer Rotary Printing Machine (Johannes Zimmer): Rotary printing machine manufactured by Zimmer company who has been for many years a worldwide leader among the producers of machines for textile and carpet finishing (digital printing systems, flat screen and rotary screen printing, coating, steaming, washing, drying). Zimmer, Kufstein, Austria. The special features of the machines were Zimmer rotary screen printing machine: this uses a magnet roll squeegee, which guarantees steady rolling of the screens and also makes it possible to use a screen stretching device which is independent of the machine. This makes it possible to fit narrow screens for narrow printing widths on wide rotary printing machines without the need to fit additional units.

Zinc carbonate ($ZnCO_3$): Its molecular weight is 125.4. Use – In textile printing (mordants, white resists, discharge agents in printing, the latter for weighted silks).

Zinc chloride ($ZnCl_2$): Its molecular weight is 136.2. White salt, extremely hygroscopic, easily soluble in water. Easily splits off hydrochloric acid when heated. Use – In textile printing (for white resists on bromine indigo, etc.), (rarely) antiseptic for sizes and chemical finishes, etc.

Zinc chloride/formic acid solution: Used in fibre identification. 100 ml of zinc chloride solution, density 1.566 (produced by dissolving 100 g of moisture-free $ZnCl_2$ in 100 ml of water, and setting the density to 1.566) are mixed with 6 ml of 98–100% formic acid.

Use – (a) Solution cold: Differentiating between 2.5 acetate and triacetate (2.5 acetate = dissolved, triacetate = merely slightly swollen). Polyamide 3, polyamide 6 and polyamide 6.6 produce Koch's contraction reaction at room temperature. Vinylal fibres reveal the same reaction as with zinc chloride-

iodine solution, but faster and with no staining. Polyacrylonitrile is insoluble; (b) Solution at 70°C (10 min) dissolves silk, slowly dissolves regenerated cellulose, does not dissolve wool, regenerated protein fibres, cotton and bast fibres.

Zinc chloride-iodine solution: Dissolve 66 g anhydrous zinc chloride and 6 g potassium iodide in 34 ml water. Next add iodine until the solution is saturated. The solution should be stored in a dark bottle as it is light-sensitive. Reactions with fibres –

- (a) Cellulosic fibres: Blue colouring, regenerated cellulose shows a deeper blue colouring than natural cellulose; woody cellulose = yellow; material which has been well broken down = blue. X- and V-transverse splits in bast fibres are heavily dyed. Natural celluloses swell, cottons show a similar reaction to that in cuprammonium.
- (b) Animal fibres are not dyed.
- (c) Acetate: Dissolution with yellow colouring and no swelling.
- (d) Polyacrylonitrile: Dissolution with swelling. Insoluble types also exist. No yellow colouring.
- (e) Polyamide, polyurea fibres: Yellow colouring and Koch's contraction reaction without dissolution.
- (f) Polyester, polyvinyl chloride: No yellow colouring or dissolution.
- (g) Polyvinyl alcohol: Initially greyish-blue, then the fibre core becomes a strong blue and is distorted into a zig-zag formation. Eventually becomes straight again and generally yellow in colour.

Zinc chloride solubility test: This is a solution of zinc chloride (54 °Bé) or 100 g molten zinc chloride + 85 ml water + 4 g zinc oxide at 100°C dissolved in approximately 15 min. Only dissolves pure silk (not tussah-silk) and acetate (gelatinous type is dissolved) in fibre blends.

Zinc chlor-iodide solution: Compound consisting of iodine, potassium iodide and zinc chloride. Used to test for acetate, cupro and viscose in fibre blends. The following colourings occur – yellow = acetate; brown = cupro; green = viscose; other fibres do not change colour.

Zinc dust: Grey powder, finely divided metallic zinc (some zinc oxide). Strong reducing agent. Used for producing indigo vats and for discharges in textile printing in olden days.

Zinc equivalent: A number related to the contents of *copper*, *zinc* and *nickel* in sludge, which can be used to estimate the safe amounts of these metals to

beapplied to the soil. The zinc equivalent should not exceed 250 mg/l and is calculated by multiplying the copper content of the sludge by 2 and the nickel content by 8, and adding them to the zinc content.

Zinc-lime-vat: Used in indigo dyeing, mainly for ordinary cotton yarn, lighter-weight piece goods and paste resist printing (Vat dyes in resist printing). Dye vat: 1000 l contain 400 g of zinc dust (flushed with water) + 2 kg of dissolved lime (mixed to a paste), left to stand overnight, indigo addition as necessary. In the case of yellow vat dye, begin with dyeing.

Zinc oxide (zinc white): ZnO. Molecular weight 81; density 5.78. Loose white powder, practically insoluble in water, soluble in acids (salt formation); temporarily yellowing when heated (slightly luminescent in the cooled state). Use: Much used pigment for viscose delustring (fixated with fatty sulphonates; dyed with cationic or direct dyes for coloured delustring); for sodium dithionite resists; resist for aniline black in printing; for producing damask effects in printing; for neutralizing naphthol-diazo- solution; production of cements, drying agents, etc.

Zinc formaldehyde sulphonylate: Colour Index Reducing Agent 6, used for discharge. This discharge agent works best in mildly acid conditions, so it is preferred, over sodium formaldehyde sulphonylate, for work on wool. It is also often used in discharge screen printing of garments.

Zinc sulphate (white vitriol) $ZnSO_4 \cdot 7H_2O$: Molecular weight is 288. Colourless crystals; weakly acid. Use: Alkali binders in naphthol dyeing, for printing mordants, as an antiseptic for sizes and chemical finishes (out of date).

Zins: General trade term in Russia for the best grade of flax, formerly taken by the church as tax.

Zip fastener (tape): A narrow fabric which may be knitted or woven and with high lateral strength, constructed so as to be suitable for the attachment, generally by sewing, or of a nylon or similar spiral along one edge. There are several different methods of incorporating the fastening elements integrally as a part of weaving process. The tape may also be formed with abeaded or thickened edge comprising of one or more suitably sized, cords to which metal or other teeth may be attached.

Zipper: A slide fastener consisting of inter-lockable elements each attached to one of the opposing edges of two tapes and a movable part called a 'slider' that spans the inter-lockable elements, which when moved in one direction causes the elements on one tape to interlock with the elements of the other tape and when moved in the opposite direction, causes the elements to disengage.

Zirkas: In Germany and Austria, a woollen or worsted dress goods, made in four-leaf, even-sided twill in various coloured patterns.

Zirpro: Zirpro treatments are a treatment developed by the International wool Secretariat, which improves flame retardance in wool fabrics.

Zirpro process: Flame retardant finishing of wool by applying titanium/zirconium salt. Application is basically possible in any wool processing stage, i.e. as loose stock, tops, yarn (hank or yarn package), piece goods (woven or knitted fabric) and carpets.

Zone of inhibition: Clear area of no growth of a microorganism, cultured onto the surface of an agar growth medium in proximity to the borders of a specimen placed in direct contact with this agar surface. A zone of inhibition occurs as a result of the diffusion of an antimicrobial agent from the specimen.

Zouave jacket: A short jacket reaching about to the waist and cutaway in front.

Z-polyethylene: Gravure printed polyethylene after its inventor Ziegler.

Z-twist: Spun yarn twist.

Zulu cloth: Twilled and closely woven cloth used for embroidery foundation in England.

Zw: Abbreviation of the no longer admissible concept–Rayon staple fibre.

Zwitterions: Term borrowed from colloquial speech for compounds which have in the same molecule a positively charged group (ammonium and sulphonium ions, more rarely carbenium or phosphonium ions), and also a negatively charged group, and can therefore be understood as intramolecular salts.

Zymosis: (a) Fermentation. (b) Reactions induced by enzymes.