

WOODHEAD PUBLISHING INDIA IN TEXTILES



**Encyclopaedic Dictionary
of Textile Terms
Volume III**

Mathews Kolanjikombil

WPI

Encyclopaedic Dictionary of Textile Terms

Encyclopaedic Dictionary of Textile Terms

Volume III

Mathews Kolanjikombil

Senior Textile Processing Technologist

WOODHEAD PUBLISHING INDIA PVT LTD

New Delhi

Published by Woodhead Publishing India Pvt. Ltd.
Woodhead Publishing India Pvt. Ltd.,
303, Vardaan House, 7/28, Ansari Road,
Daryaganj, New Delhi - 110002, India
www.woodheadpublishingindia.com

First published 2018, Woodhead Publishing India Pvt. Ltd.
© Woodhead Publishing India Pvt. Ltd., 2018

This book contains information obtained from authentic and highly regarded sources. Reprinted material is quoted with permission. Reasonable efforts have been made to publish reliable data and information, but the authors and the publishers cannot assume responsibility for the validity of all materials. Neither the authors nor the publishers, nor anyone else associated with this publication, shall be liable for any loss, damage or liability directly or indirectly caused or alleged to be caused by this book.

Neither this book nor any part may be reproduced or transmitted in any form or by any means, electronic or mechanical, including photocopying, microfilming and recording, or by any information storage or retrieval system, without permission in writing from Woodhead Publishing India Pvt. Ltd. The consent of Woodhead Publishing India Pvt. Ltd. does not extend to copying for general distribution, for promotion, for creating new works, or for resale. Specific permission must be obtained in writing from Woodhead Publishing India Pvt. Ltd. for such copying.

Trademark notice: Product or corporate names may be trademarks or registered trademarks, and are used only for identification and explanation, without intent to infringe.

Woodhead Publishing India Pvt. Ltd. WebPDF e-ISBN: 978-0-429-89330-8

Typeset by Bhumi Graphics, New Delhi

Contents

Preface *vii*

Volume I

- | | |
|------|-----|
| 1. A | 1 |
| 2. B | 99 |
| 3. C | 222 |

Volume II

- | | |
|-------|-----|
| 4. D | 409 |
| 5. E | 511 |
| 6. F | 552 |
| 7. G | 659 |
| 8. H | 704 |
| 9. I | 761 |
| 10. J | 794 |

Volume III

- | | |
|-------|-----|
| 11. K | 811 |
| 12. L | 834 |
| 13. M | 889 |

14. N	975
15. O	1006
16. P	1034
17. Q	1160
18. R	1165

Volume IV

19. S	1227
20. T	1405
21. U	1494
22. V	1507
23. W	1532
24. X	1586
25. Y	1588
26. Z	1605

Preface

It has been told the first thing that a business man should know, is—the little things of his business. This book is meant for textile personae, be it a textile student, textile chemist, a spinner, a weaver, garment maker or a merchandiser who may be an expert in his/her field but he/she may come across many terms in his/her day to day business which he/she is not familiar with but is related to his/her field which he/she should know, but nine times out of ten does not know. He/She may not have an expert in that field of that term near him/her to clear his doubt about that term. This book comes handy in such circumstances.

There is nothing scholarly in this book, but is a compilation of short easy understandable meanings of the textile terms enough to help the referrer to understand the term. I have come across dictionaries which gives the meaning of the textile terms in one sentence. But it may not be sufficient to give a full idea about it. But this book is a little different. The meaning of the terms is explained in a concise manner even with the help of diagrams or photos, wherever necessary, which is enough to clear his/her doubts. These terms and meanings have been collected right from my college days and throughout my career. I believe it is not complete, but, such as it is, the compilation is reliable. There are further terms which are being collected by the author which will be added in the next edition, probably. The author believes that he has produced a book which may be profitably consulted by all who are either interested or practically engaged in textile trade.

It has to be specially mentioned that students can use the present book as a reference guide for his/her immediate needs without going to many textbooks. For detailed study of any terms he/she can further refer to books specialized in that field. I may not suggest this book for a research student. The author has also tried to explain the construction of many fabrics new or old for general knowledge.

Hope this book will be greatly accepted by textile personnel. Any suggestions or corrections are welcome, which will be included in the next editions.

Mathews Kolanjikombil

Senior Textile Processing Technologist

Bangalore

Dedication

*This book is dedicated
to my Father (Thomas
Abraham) and my
Mother (Thankamma
Abraham) who solely
made me what I am
today.*

K

K index: (1) Index in general is used for characterizing a commercial grade of polyvinylchloride, calculated from its viscosity in solution and indicating its molecular weight. Polyvinylchloride with a K value of approximately 68–80 is usually used for coating. (2) Index is used for the classification of basic (cationic) dyes with respect to their rate of strike (Association index K). (3) Index is used in association with machines for measuring fabric length because of the effect on standardized length measurement due to the stretching of the material.

KA: Casein fibres.

Kabakaraman rugs: Coarse and heavy, small rugs made by the nomad Karamanian in Asia Minor. The warp and weft are of heavy and coarse wool. The long and very loose pile is tied in G-hordes knot. The design is usually that of a prayer rug.

Kabistan rugs: Very fine rugs made in Caucasia with cotton web, occasionally wool warp, and short, wool pile, tied closely in G-hordes knot. The designs are geometrical, stars and diamonds and pearls in rows often occur. The field is often divided into horizontal rows of pears or finely blended stripes. The border often contains conventionalized animal figures. The ends are finished with a narrow selvage and a loose or knotted fringe. The sides are overcast, occasionally having only one warp thread left.

Kabylo: French shawl, made with carded warp and filling.

Kachoji: Mosquito netting in Japan.

Kadu: Sleeping mat in Java, made of palm leaves.

Kaffir hemp: Very strong, white bast fibre, yielded by the South African, the *Grewia occidentalis*; used for rope and cloth toy the Kaffirs.

Kaffir sheet: Very coarse, twilled cotton fabric, with fancy coloured heading; used for garments by the natives of South Africa.

Kaga: Trade term for the medium grade Japanese silk fabrics.

Kagotsuko printing: Typical Japanese resist printing process, comparable with paste resist printing. See **Resist printing**.

Kaikai: A thin, cheap Japanese silk fabric.

Kaimakani: Fine sheer cotton cloth; used in Turkey to bind the turbans with.

Kairens: Turkish wool rug of good quality; used as floor and furniture cover.

Kairuan: Rug from Tunis, made by the natives of wool with hand tied knots.

Kaisarich rugs: Very bright-coloured hand-knotted rugs; the cotton or silk pile is tied in Ghiorde's knot; made in Kaisa, in Asia Minor.

Kakarally: Very fine and thin layers of fibrous bast, obtained from the Monkey-pot tree in South America; used for wrapping, cordage, baskets, etc.

Kakeda fine: Japanese raw silk.

Kalamal: Striped cotton fabric with a white ground; used in Turkestan for dresses.

Kalasisis: Ancient national robes for men and women; narrow shell with straps, richly ornamented, shift style, transparent and finely pleated.

Kalga: Indian applique work; used for curtains and covers.

Kalamkari: Traditional printing with vegetable colours in India.

Kalmuck (fries, swanboy): In general, a 2-sided strongly raised soft cotton fabric, weight and roughened effect are even more marked than in Melton; twill(cross) weave with back pick or as double cloth, striped or with a check pattern. Also long-haired, coarse, thick woollen fabrics. Application for heavy blankets, bed padding, table under-cloths, back-cloth materials, ironing board and mangle covers.

Kaloz process (lime and ozone): It is a combined process for effluent cleaning, as a single stage or sequentially (better results) by the precipitation of organic/inorganic impurities using calcium hydroxide. By the use of the correct techniques, even fused and difficult to oxidise substances be made to oxidise more easily. Particularly suited for the cleaning of textile effluents due to its good decolourising effect.

Kama: Japanese trade term for the cotton cop.

Kambaliya: A *bandhani* design. See **Bandhani**.

Kamdani: Ancient Indian gold embroidery (silk thread wrapped in metal foil) of lighter style on fine fabric.

Kanakin: Generic trade term in Japan for a variety of plain woven cotton goods, shirting and print cloths.

Kanthas (embroidered quilts): Made from old saris and dhotis, for generations, by women of West Bengal, India, using coloured threads from borders for motifs and white and off-white thread from ground fabric for

quilting. Rich folklore and landscape of rural Bengal with its green paddy fields, rhythm of seasons, festivals and daily life, rivers with boat and fish, animals, birds and plant life inspire the repertoire of motifs of *kanthas*. A style similar to the *kantha* are made in the neighbouring states of West Bengal called *Ledra* in Jharkhand, and *Sujini* in Bihar, India

Kaolin: China clay, porcelain clay, terra alba, $\text{Al}_2\text{O}_3 \cdot 2\text{SiO}_2 \cdot 2\text{H}_2\text{O}$, density 2.1–2.6. White, loose powder, practically insoluble in water. Application – with starches and oils for filling and softening of finishes (bleached cotton goods, light coloured lining fabrics); pigment for viscose de-lustring (fixed in particular by sulphonated surfactants); also as spotting powder; as tailor's chalk, etc.

Kapok: Vegetable hair fibres from the fruit pod of tropical cotton of the *Bombaceen* family (kapok, cotton or silk cotton; East and West Africa, India, Java, Sumatra, Mexico, Brazil). The fibre resembling cotton but silkier, it is a seed fibre which is round, smooth and light. It is only used as a bulky soft filling in upholstery, cushions, mattresses, toys, etc.

Karabagh carpets: Knotted carpets from the Southern Caucasus, patterning and colours similar to Kazakh carpets, but shorter pile made of less lustrous wool. Approximately 1,50,000 Turkish knots per m^2 .

Karl-Fischer method (KF process): Simple and volumetric process for water determination, based upon the fact that iodine oxidizes sulphur dioxide to sulphuric acid in the presence of water. Particularly suitable in the presence of the smallest quantities of water in organic solvents, dyes, also in textiles.

Kasan: In Germany and Austria, a woollen dress goods that is similar to a stout flannel.

Kasha: (1) Kasha may also be a cotton flannel, with a napped right side, slightly ecru in colour and made as sheeting.

(2) A softly napped fabric with a crosswise streak caused by darker hairs, may be made of fine wool and Tibet goat hair.

Kashan carpets: Knotted carpet from Central Persia. Fine ornamentation on a matt red, violet or dark blue background. Around 3,50,000 Persian knots per m^2 . Low, smooth pile made of fine wool.

Kasheda: Indian fabric, made of wild silk, often mixed with cotton, and embroidered.

Kashgar: Coarse cotton rugs with long loose wool pile tied in Senna knot. They are made in Central Asia. The design consists of Chinese fret, dragons, fish, etc., in bright pinks, orange, yellows, etc.

Kashgar cloth: Thick but light dress goods made of Kashgar wool; It has a long, napped face.

Kashkai: Collective name for Kermanshah, Shiraz and Mecca rugs.

Kashmere silk: A fine silk produced in Kashmir, India.

Kashmir rug: Another name for Soumak rugs.

Kashmir shawl: See **Cashmere shawl**.

Kasida: Sort of Dacca muslin (see), embroidered in floss silk; used for scarfs, turbans, etc.

Kassapbatchi: Coarse Turkish skin wool; used for carpets.

Kasuri: See **Kasuri dyeing**.

Kasuri dyeing (Kasuri-Resist): Laborious, old Japanese dyeing technique of a white patterning on coloured ground by the partial resist of warp and weft threads and subsequent over-dyeing.

Kata aya: General trade term in Japan for twilled cotton shirting.

Katox-system: An effluent treatment system that can be used together with other systems to create a complete effluent treatment plant for textile processes. It is based upon an activated carbon system that carries biologically active media in cyclone baths.

Kattun: German for calico.

Kawamatta: Trade term for inferior grades of Japanese silk fabrics.

Kawabata system: System developed in Japan for handle evaluation (Kawabata system of handle evaluation). Describes fabric handle in terms of 0 (slight) to 10 (very marked) with an overall rating scored as 0 (unacceptable) to 5 (excellent). In this system, various characteristics are used for handle evaluation:

- (a) Fukurami = fullness and softness
- (b) Hari = "non-drape" stiffness
- (c) Kishimi = scroopy handle
- (d) Koshimi = stiffness and elasticity
- (e) Numeri = flexible smoothness
- (f) Shinayakasa = suppleness with softness
- (g) Sofutosa = soft handle feel

These characteristics can be detected using four devices:

- (i) KES-F-1 for measuring fabric behaviour under tensile and shear loading.

- (ii) KES-F-2 for measuring bending behaviour.
- (iii) KES-F-3 for measuring fabric behaviour under compressive loading.
- (iv) KES-F-4 for measuring surface characteristics of the fabric.

A complete evaluation of a fabric can take 6–8 hours depending upon type.

Kawokawo: Silky, yellowish seed hair of the Bombax tree in the Malay States.

Kaya: A mosquito netting made in Japan.

Kazakh carpets: Tightly knotted, long pile carpets from the Caucasus. The large, bold, geometric patterning in bright dark-red, blue, green, yellow and light ivory is typical. Dull silk sheen wool pile. 120000–200000 Turkish knots per m². The term Kazakh carpets is often wrongly used as a collective term for Caucasian carpets.

Kazeto: Japanese trade term for a spool containing about 54 feet of hand spun cotton yarn.

Kasuri: A hand woven cotton fabric in Japan, showing irregular white checks on a blue ground. It is made in plain weave of yarn, which is tied up at certain intervals with a string before dyeing. These places remain intact by the dye and form the white spots. It is used mostly for clothes for the native school children.

KE: Kenaf.

Kedis: Stout cotton shirting and lining in Asiatic Turkey.

Kefieh: Printed cotton cloth, measuring about 42 inches square; used as head covering in Asia Minor.

Keith: Commercial variety of early maturing, prolific cotton from Alabama, the staple measuring 24–26 millimetres; the yield is 32–34 percent.

Kekchi: Raw cotton from Guatemala, the staple being of good length and quality.

Kelly: Commercial variety of prolific and late maturing American cotton, the staple measuring 26–30 millimetres; the yield of lint is 30–31 percent. Also called Marston.

Kelly green: A strong mint green colour.

Kelt: Scotch frieze made of natural black faced wool.

Kelvin: The unit of thermodynamic temperature; the SI unit of temperature for which an interval of one Kelvin (K) equals exactly an interval of one degree Celsius (1°C) and for which a level of 273.15 K equals exactly 0°C. According to this scale, short wave radiation (light wavelength) has a high

colour temperature and, conversely, blue light has a high colour temperature and red light a low colour temperature. In practice direct sunlight is 5000–65000 K, blue diffuse light is 5700–6600 K, white light with a completely overcast sky is 6400–6900 K and with a clear blue sky is 19000–24000 K.

Kemea: Indian all-silk taffeta made with flower patterns.

Kemp fibre: A medullated animal fibre in which the diameter of the medulla is 60%, or more, of the diameter of the fibre.

Kemp: Diseased wool fibres, with unevenly developed medulla which causes streaks in dyeing. It is a coarse, white and undeveloped fibre.

Kemuku: Japanese silk waste, yielded by the outer skin of the cocoon in reeling.

Kenaf: Bimli-jute, Gambo hemp, Ambari hemp, Bombay hemp, Mestha, similar to jute bast fibres (India, Soviet Union, China, Korea, Taiwan, Philippines, South Africa, Brazil, Cuba). The basic fibres have irregular wall thickness, an average length of 2 mm and a width of 20 μm . As jute substitute and mixed with jute for the manufacture of packing material, ropegoods and fabric. In addition to the fibre extraction, the plant is also used for the production of oil.

Kendal: A coarse English tweed of green colour in the 14th Century; used for clothing.

Kendyr fibre (Turka fibre): It is of the bast fibres family. A winter resistant plant fibre from Turkestan. The stalk is cut annually; preparation takes place in a similar way to flax. The pure white, 80–120 cm long bast bundle with fibre strength up to 55 cN/tex can be processed by linen and tow spinning; by cottonising the kendyr fibre can also be used for fine spun yarn (mixing with cotton). The most important field of application is in the manufacture of highly rot-resistant fishing nets.

Kennedy: A Highland tartan, composed of a green ground, dark-blue and black checks and red and yellow lines.

Kensington quilt: Has large patterns formed of coarse thread on a fine plain woven ground.

Kenting: Thin, sheer Silesia linen fabric.

Kentucky jean: Very strong, stout, weft face fabric, made with cotton warp and wool filling in satin weave; used for trousers, etc.

Keratin: One of a group of fibrous insoluble sulphur-containing proteins (scleroproteins) found in ectodermal cells of animals, as in hair, horns, and nails. Leather is almost pure keratin. There are two types: α keratins and β

keratins. The former have a coiled structure, whereas the latter have a beta pleated sheet structure (Gk.: horn material), High molecular Protein substance (sclera protein) containing cysteine.

Keratose: High-molecular wool oxidation product, consisting of β -keratose (cuticula), α -keratose (microfibrils) and γ -keratose (matrix).

Kerf: In England, the flock resulting from shearing the cloth.

Kermanshah rugs: Usually all-wool Persian rugs. The medium long, close pile is tied in Ghiordes knot. The design usually consists of floral patterns, often small palm leaves in rows.

Kermel: Kermel is a polyamide-imide fibre made from either trimellitic anhydride chloride and a diamine or a diisocyanate. These polymers have reasonable thermal stability, very resilient and have excellent flame-resistance.

Kermer: A shawl made of pure silk, or mixed with cotton, worn by the women in Egypt.

Kermes: Red colouring matter, yielded by the dried bodies of the *coccus ilicis*, a small insect. It is ground up in hot water, producing the carmine. Extensively used in past centuries to dye silk and wool fabrics. Active component – carmine acid, related to Cochineal. Mordant dyes for wool and silk. Light fastness and luminosity of equal value to the expensive purple.

Kerr: A Highland tartan, made as follows – Wide red bar, split in the centre by three narrow black stripes which are spaced their own width from each other; black stripe, about one-sixth in width of the red bar; dark green bar, same in width as red bar, split with a pair of black stripes (as wide as those in the red bar) near each edge, these black stripes being spaced from the edge of the green bar and from each other their own width.

Kersey: (1) A woollen cloth originated in Kersey, Suffolk in 11th Century. Medium to heavy weight, similar to Melton and beaver. It has a lustre caused by the use of cross bred wool and is a very heavy, thick wool coating fabric which has been fulled and also felted. Nap often has direction. Often twill weave, although the face finish that is applied conceals this. It is a conventional cloth in appearance and not much used now except for classic overcoats or in lighter weight for a classic black dress. It may contain some acrylic fibre nowadays. Gives good wear and is dressy looking. Blues, browns and blacks are the most popular colours. Very similar to beaver but it is fulled more, has a shorter nap and a much higher lustre. Uses: Men's overcoating, uniforms, women's coats, and skirts.

(2) A heavy, closely woven cloth with a smooth face and glossy finish.

Kerseymere: A fine, twilled, woollen cloth of peculiar texture, one thread of warp and two of wool being always above.

Kerseyne: Light English fabric, made with cotton warp and woollen filling; used for men's clothes.

KES-F-System: Kawabata's Evaluation System for Fabrics. See **Kawabata system**.

Kettle cloth: Made of cotton and polyester, plain weave stiff fabric, with a dull surface and a slight slub in the weave, which may be coloured. Used for men's light summer jackets, trousers for men and women and other casual dresses.

Kevegik: Turkish skin wool of merino sheep.

Kevlar: Kevlar, modified nylon, poly (p-phynylene terephthalamide) represents a break-through in high modulus aromatic polyamide fibre and mainly used as reinforcement tyres, conveyers belt etc., made by DuPont.

Key-lock principle: In 1894, Emil Fischer developed the theory to explain enzyme specificity, that the surface of an enzyme possesses a pocket (the "lock"), into which the substrate fits sterically like a "key", enabling the process of enzymatic catalysis to function.

Keymo: A finishing process, rendering woollens and worsteds unshrinkable by a bath of sulphuric acid.

Khabbikutah: Collective name for various non-descript short pile, knotted Persian rugs.

Khadi (Khaddar): An Indian handloom fabric usually made with hand spun yarn. It will have a characteristic rough appearance because of the unevenness of the spun yarn due to the hand spinning. Propagated by Mahatma Gandhi during the Indian Independence struggle, to replace the machine made cotton imported from Europe.

Khaddis: Indian name for wooden looms used in earlier days.

Khaiki: A plain woven and washable light Japanese silk fabric.

Khaki: (1) A light, yellow-brown coloured cotton cloth used for army service in hot countries; (2) A khaki-coloured cloth of cotton, wool, or combinations of these fibres with manufactured fibres used primarily in military uniforms and work clothes.

Khali: Natural brown felted Persian fabric, embroidered in coloured silk and silver flowers.

Khandeish: Indian cotton, having a harsh, strong, and very dirty staple of golden colour.

Kharajobi: Name for a great variety of gold and silver embroidery made in India.

Kharjikhani: Indian embroidery work in gold and silver.

Kharwa: Red Indian cotton fabric; used for ticks.

Khasa: Cotton muslin from India.

Kheetee: Indian chintz.

Khemir: Silk shawl from Egypt.

Khersek: Heavy Persian woollen rugs with a shaggy pile.

Khes: Stout Indian cotton fabric made with check patterns or coloured, often gold border.

Khilim rugs: These come in all sizes made in Anatolia, Persia, Turkestan and several of the Balkan States. They are woven by hand and have no pile, the weft being of hard twisted wool. The design, which is alike on both sides, consists of angular geometrical figures in a great variety of colours. They are used for divan covers and portieres.

Khiva: Fine, all-wool rugs of small size, made in Turkestan, the short, close pile being tied in Senna knot. The design consists of octagonal figures or the prayer rug pattern in rich reds, blue, ivory and a little green.

Khokti: Yellowish or brown cotton cloth made in India. It is very durable, smooth, and glossy, the finest grade being similar to the best brown Holland.

Khoktibanga: Variety of East Indian raw cotton, having a yellowish but good, strong staple.

Khonia: Indian cotton shawl with richly embroidered design.

Khorassan:(1) Variety of Persian wool of long and fine staple; (2) Medium and large size Persian rugs with close and medium long fine wool pile tied in Senna knot and clipped unevenly. The pattern consists usually of fish or palm design the latter having smaller ones placed in each large one. The border usually has trailing palm leaves. Magenta and blue are characteristic colours.

Khoseb: Originally a fine muslin from Egypt; used for turbans.

Khudurangi: Native East African name for a coarse cotton fabric, dyed with henna.

Khum: Dyed Terry cloth in Turkey; used for long coats by the natives.

Khuskus, Cuscus: The roots of this grass (*Andropogon Muriaticus*) are used in India for mats and baskets.

Khustka: Shawl from Southern Russia, embroidered with coloured floral designs.

Kibisu: See **Frison**.

Kick tape: A binding of twill or herringbone twill, usually, 3/1. Originally made with silk warp and polished cotton weft, but now made with mercerized cotton warp or rayon warp and weft and woven in such a way as to give the article a stiff handle.

Kidderminster carpet: Double cloth carpets, in which two layers of cloth, manufactured from two warp and weft systems, lie on top of each other. The patterning is created by the threads of the cloth layers alternating, i.e. the wefts are inserted in tiers, which are sometimes formed by the warp threads of the upper cloth and sometimes by those of the lower cloth. This has the effect on the pattern that a red figure on a blue background on the front appears on the back as a blue figure on a red background (reversible carpet). It is woven without the use of heald shafts exclusively with Jacquard machines, with the depth of the harness being split according to the number of cloth layers. The Scottish or tree-ply carpet consists of three layers of cloth. These flat but thick carpets usually made of wool yarn were first produced in the English town of Kidderminster.

Kidney: Cotton Trade name for Brazilian cotton.

Kienchow: Silk Foulard with pressed in patterns, made in China; is about 16 inches wide.

Kikci or Kikoy: A heavy grey cotton sheeting in the Eastern parts of Africa, having yellow, black and red border stripes; used for garments by African tribes.

Kier: A pressure vessel used for boiling textile material.

Kier boiling: In kier boiling (alkali-boiling) of cotton materials, the cotton is heated with dilute NaOH solution under pressure for several hours, in the absence of oxygen. Small quantities of detergents and solvents are frequently added. The objective is to eliminate the waxy cotton cuticle, the natural oils, waxes and proteins as well as various salts and soluble cellulose and carbohydrate derivatives. It also helps to remove any size residues. The removal of the hydrophobic constituents of the cotton fibres renders them absorbent. In many modern plants, much faster, continuous processes of this type use higher concentrations of NaOH. They are, however, less efficient than the classical kier process because of the short treatment times.

Kier boiling fastness: It is a fastness assessment whether a dyed or printed material is able to withstand weak NaOH under pressure. Test method – treat test piece wound in raw cotton fabric of 10 fold weight for 4 h at 120°C and 98 100 Pa in the kier boiling liquor with a liquor ratio of 1:50 in the pressure

boiler. Solution I: 4 ml/l NaOH 35.5%; Solution II: 4 ml/l NaOH 35.5% + 4 g/l m-sodium m-nitrobenzene sulphonate. Evaluation with grey scale.

Kier decatizing: A finishing process for wool and its blended fabrics for achieving dimensional stability, voluminosity, handle and sheen. These are rolled up with backcloths (satin or molleton fabric) and treated in an evacuated boiler with saturated steam. Remaining shrinkage value is below 1%.

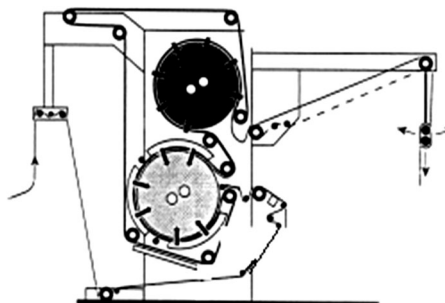

Double drum kier decatizing machine

Kier lining: Treatment of pressure kiers and bleaching boilers with milk of lime, cement and water glass solution to prevent kier and bleach stains when the material touches unprotected boiler walls.

Kier stains: It arises due to unfavourable working conditions, such as hard, turbid water, poor, one-sided liquor circulation, inconsistent packing of the kier boiling material (channelling), wrong rinsing (cold instead of boiling hot), etc. This usually causes brownish deposits and uneven stains, which can only be removed by repeating the kier boiling or hot acid souring and boiling with sodium carbonate.

Kiering: The process of boiling of textile in a large pressure vessel called Kier.

Kilim: See **Khilim**.

Kilim carpets: Woven, bright, originally Turkish flat carpet with coarse wool weft. Sometimes with woven perforations, i.e. small open cracks on the border lines of the multi-coloured pattern. Used as floor carpet on thick felt underlay.

Kilmarnock: (1) A coarse 18th Century Scotch serge; (2) See **Kidderminster**.

Kilo: (Gk.: chílioi = thousand), unit prefix for one thousand times = 1000.

Kilogram: A unit of mass (weight) in the metric system; approximately equal to 2.2 pounds avoirdupois. 1 kg is the mass of the international kilogram prototype of a platinum-iridium body stored in the vicinity of Paris. In

processing, since one litre of water weighs one kilogram, it makes calculations such as percentage of a chemical owg, or liquor ratio, etc., easy.

Kinari: Trade term for Persian pile runners of various characters and origin.

Kincob: Fast Indian silk muslin, richly interwoven with gold or silver brocade (zari); used for men's and women's dresses. It was made in Varanasi but until 16th Century, the best of this material was coming from Ahmedabad. Commonly known as kimkhwab (anglicized to kincob, although the root word is Chinese kim-hoo-gold flower). These Ahmedabad brocade were sold four times their weight in gold on African East coast. The beauty of Ahmedabad's kincobs lay in the colourful inter-weaving of silk into designs with gold and silver threads. They were also famous for their strength and durability. First the Portuguese piracy, and then the rise of Surat as a centre of weaving under the English wiped out the craft completely in Ahmedabad.

Kindergarten cloth: Stout, heavy, plain woven cotton fabric, usually made with yarn dyed warp stripes. The warp is single yarn, two ends drawn in. The number of ends is almost three times higher than the number of warps; used for children's clothes.

Kinetic chain-length: It is defined as the average number of monomer molecules contained per radical which initiates a polymer chain.

Kinetic friction: Friction developed between two bodies in motion. Compare *Static friction*.

King: An improved variety of early maturing commercial variety of prolific upland cotton, the staple measuring 25–28 millimetres; the yield of lint is 32–34 percent.

King bobbin: One-sided conical packages with precision cross-winding.

King spool: A thread cone that has a vertical tube with a horizontal base.

King's blue: A light blue colour, resulting from mixing ultramarine and **Cremnitz white**. See **Cobaltblue**.

King's yellow: A brilliant yellow colour.

Kingfisher blue: A brilliant blue colour. Also referred to simply as 'kingfisher'.

Kinik: Variety of Turkish raw wool.

Kinjishusu: Japanese silk satin with a partly or completely gilded face; used for kimonos.

Kink: A short length of yarn that has spontaneously doubled back on itself to form a loop in the yarn or fabric.

Kink (in fabric): A short length of yarn that has spontaneously doubled back on itself to form a loop.

Kink (in rope): An abrupt bend or loop in the rope, which is the result of an unbalanced twist relationship in the rope structure.

Kinkale: Light bast Indian silk, brocaded with silk or gold threads.

Kinking: The doubling back of yarn on itself to relieve torque imparted by twisting or texturing.

Kinky thread: See **Kink**.

Kiotonan: Chinese satin with damask figures.

Kir-Shehr rugs: Made in Angora, Asia Minor, the warp, and weft are of dyed wool, the long pile is tied in Giordes knot. The Arabic designs are in brilliant greens, reds, and blues. The sides and ends are salvaged.

Kiss dyeing process: Dyeing liquor application onto the fibre tips or on the back, often for carpet material.

Kiss print: Special printing technique used in the rotary screen printing of carpets. Carpet transport on a needled backcloth, which can be adjusted by electric push-button control. By controlling the height between backcloth and template a tunnel is formed, the height and thickness of which correspond with those of the carpet. Because this does not alter the position of the pile, a sharp printing edge is obtained.

Kiss roll (lick roller): See **Kiss roll applicator; Cover roller**.

Kiss roll applicator: A kiss roll applicator consists of a drum rotating in a trough containing the finish. A layer of liquid is picked up by the drum surface. This liquid is transferred onto a fabric “kissing” the exposed section of the drum. Kiss roll applicators are relatively simple devices. Within certain ranges, the wet pick-up can be adjusted to meet whatever is desired by controlling the variables stated above. However, uncontrolled variations in fabric speeds or drum rpm will cause unwanted variations in fabric properties.

Kitay: Fancy coloured Chinese silk and cotton cloth.

Kittool or Kitul: Black, very coarse, straight, smooth, glossy and strong fabric, obtained from the leaves of the kit tool palm found in India and Sri Lanka; used for strong ropes, brushes, mats, etc.

Kleanka: A Russian buckram.

Km: Camel hair; Kilometre.

Knap: Coarse, blue woollen, used for sailors’ clothes in England.

Knee (in anatomy): The joint between the lower and upper leg.

Knee break-out test: A method to evaluate the performance of fabrics, especially boys' wear, when subjected to abrasion, stretch, and impact forces under conditions which simulate ordinary wear at the knee.

Knee girth (in body measurements): With the leg straight, the circumference of the knee over the kneecap and parallel to the floor.

Knee lifter: A lever under the sewing machine table which, when operated by the machinists knee, lift the presser foot.

Kneeing: (1) An unstable condition arising in melt spinning wherein the extrudate forms an inflexion on leaving the spinneret instead of drawing down directly from the orifice. The molten filament thus has a knee-like shape, just below the orifice.

(2) Abnormal behaviour of a spinning threadline (especially in melt spinning) in which one or more filaments form an angle (knee).

Kneipp linen: Porous, rough faced, twilled linen fabric, made in Germany and Austria; used for towels and underwear. Originally it was knitted.

Knib: Technical term for knots, or uneven places on the silk fibre.

Knickerbocker: (1) Rough faced wool and cotton mixture dress goods, made with nub yarns. It comes in mixture colors.

(2) In weaving, an effect produced by rough knotted yarns; similar to boucle and bourette.

Knickerbocker yarns: Yarns with coloured nubs made by printing the card sliver.

Knickerbockers: Knee breeches.

Knife (in tufting machine): A flat sharpened blade which operates in conjunction with the looper to cut the formed loops to form cut pile carpet.

Knife-coating principle: The knife application unit (spreader) consists of the doctor blade holder; the doctor blade with lateral limit blocks and possibly a doctor blade liner. The coating substance is applied to the doctor blade which is set at a defined distance between knife and fabric using the doctor blade holder. In continuous coating, the base material moves under the fixed doctor blade which causes the coating of the coating substance on to the material depending on the doctoring speed, doctor blade tilt angle, doctor blade profile, doctor blade distance, base material tension, paste viscosity.

Knife coaters: A knife-coater is a metering device that continuously spreads viscous liquids onto fabric. This type of equipment is commonly used in the coated fabrics industry. It consists of a stationary knife blade positioned over a fabric support. The material applied to the fabric is fed to one side of the knife blade as the fabric moves continuously under the spreader. The amount deposited on the fabric is controlled by the gap formed between the blade and the fabric.

Knife-on-blanket coating: Doctor blade for coating and laminating which is supported on an endless rubber blanket.

Knife pleat: A pleat with folds lying flat and facing in one direction.

Knifing: Carpets with polyacrylonitrile or polyamide cut pile are drawn under a doctor blade to align the pile in warmed state.

Knit fabric: Knit fabric are made from all fibres and blend of fibres. The thickness and weight may be anything from very fine to coat weight.

Knit texturing: See **Texturing, Knit**.

Knit-de-knit: See **Texturing, Knit-de-knit method**.

Knit-de-knit method (Whitaker process): A knit-pressure-fixation-rewinding process for the texturizing of yarns (similar crinkle).

Knit-miss: A form of tricot knitting in which yarns on each bar of a two-bar machine are knit at alternate courses only. This type of knitting permits the use of heavy-denier yarns without creating undesirable bulkiness in the fabric.

Knits: Knitted material.

Knitted carpet (knitted velvet pile carpet): It is created from knitted fabric bonded to a stabilising fabric. A backing is then attached to this composite material. The pile layer is usually roughened, creating the knitted velvet pile carpet. See **Stitch bonding, Raschel** and **Raschel batt-on-base carpet**.

Knitted composites: Bonded in the interweaving or cross-stitch methods; similar to stitch bonded fabrics. See **Bonded fabrics**.

Knitted curtains: The development of Rachel machines for high production with unlimited possibilities, development of filament yarn which is best suited for the curtains, attractive pricing of knitted materials has caused the manufacture of knitted curtains (warp-knitted fabrics) into an important branch of knitting.

Knitted fabric: A structure produced by interloping one or more ends of yarn or comparable material. Collective term for warp-knitted and knitted fabrics

– Textile materials made of stitches; loop and floating using single or multi-thread systems with a horizontal or vertical thread path. Unlike woven fabric which consists of two thread systems crossing each other at right angles, warp knitted and knitted fabrics are textile materials of which the smallest unit is the stitch.

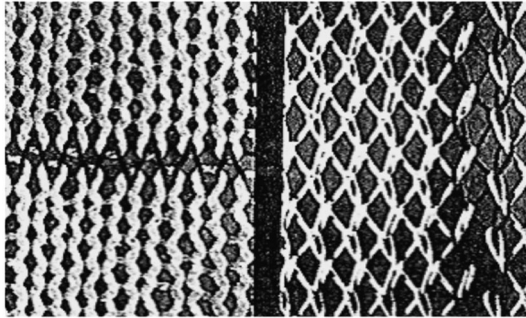

Knitted fabric: See **Fabric (knitted)**.

Knitted loop (in weft knitting): A basic unit of any knitted fabrics consisting of a loop of yarn meshed at its base with a previously formed loop.

Note: The point of mesh with the previously formed loop is usually open but may be crossed. The component part of the knitted loop may be identified as back loop. A knitted loop viewed such that it meshes through the previous loop away from the viewer face or plain (weft knitting); a knitted loop viewed such that it meshes through the previous loop towards the viewer. Needle loop: The upper curved portion of a knitted loop derived from that part of the loop formed by the needle. Sides or legs: The part of the knitted loop that connects the sinker and needle loops. Sinker loops: The lower curved portion of a knitted loop derived from that part of the loop formed by a sinker on machine employing this type of element.

Knitted plush: Plush cloth (e.g. for imitation fur), manufactured knit goods with cut plush loops that are firmly bonded to the knitted base. Manufactured on circular knitting machines and tubular hosing machines.

Knitted welt: A secure edge of a knitted fabric or garment made during or subsequent to knitting usually parallel to the courses and at the starting end of the fabric.

Knitting: A method of constructing fabric by interlocking series of loops of one or more yarns. The two major classes of knitting are warp knitting and weft knitting, as follows:

- (a) *Warp knitting* – A type of knitting in which the yarns generally run lengthwise in the fabric. The yarns are prepared as warps on beams with one or more yarns for each needle. Examples of this type of knitting are tricot, milanese, and raschel knitting.
- (b) *Milanese knitting* – A type of run-resistant warp knitting with a diagonal rib effect using several set of yarns.
- (c) *Raschel knitting* – A versatile type of warp knitting made in plain and Jacquard patterns; the latter can be made with intricate eyelet and lacy patterns and is often used for underwear fabrics. Raschel fabrics are coarser than other warp-knit fabrics, but a wide range of fabrics can be made. Raschel knitting machines have one or two sets of latch needles and up to thirty sets of guides.
- (d) *Tricot knitting* – A run-resistant type of warp knitting in which either single or double sets of yarn are used. See **Tricot**.
- (e) *Weft knitting* – A common type of knitting in which one continuous thread runs crosswise in the fabric making, all of the loops in one course. Weft knitting is of two types, i.e. circular and flat knitting.
- (f) *Circular knitting* – The fabric is produced on the knitting machine in the form of a tube, the threads running continuously around the fabric.
- (g) *Flat Knitting* – The fabric is produced on the knitting machine in flat form, the threads alternating back and forth across the fabric. The fabric can be given shape in the knitting process by increasing or decreasing loops. Full-fashioned garments are made on a flat-knitting machine. See **Flat-knit fabric**.

Knitting machine: A machine for the production of fabric by warp knitting or weft knitting. The different type of warp and weft knitting machines are classified and names primarily, according to (a) the type of fabric or garment they are intended to produce; (b) the type of needles used; (c) the format and arrangement of their needles or their needle beds. Machines are also distinguished by the type of patterning control used and by whether they are hand or power operated.

Knitting machine (double bed): Double-bed circular knitting machines are equipped with two series of needles – one series of needles fits in the circular needle-bed called “cylinder”, while the other series is accommodated inside radial grooves positioned at 90° with respect to the cylinder, on a special circular plate called “dial”. Double-bed circular knitting machines usually incorporate latch needles, but a few manufacturers also offer machines

equipped with compound needles. The cams that command the various needles are fastened to two cam frames, one around the cylinder and the other above the dial.

Knitting machine (large diameter): Large-diameter circular knitting machines are those having diameter from 24 to 40 inches. Large-diameter machines are mostly designed for manufacturing tubular fabrics, while a more restricted number of large-diameter machines are used to manufacture fabrics similar to those manufactured with flat knitting machines.

Knitting machine (medium diameter): Machine diameters from 8 to 22 inches are called medium diameter knitting machines. Medium-diameter machines are designed for the production of body-sized tubular fabrics as well as fabrics with welt and separation thread, ideal for the underwear market.

Knitting machine (single bed): Single-bed circular knitting machines are equipped with only one series of needles sliding in the grooves of a circular needle-bed. The needles are usually latch needles, but a few manufacturers have designed machines equipped with compound needles. The cams, which drive the movement of the needle forming the stitch, are placed outside the needle-bed; each feed system is provided with its own cam group.

Knitting machine (small diameter): These are the machines which having diameters from 3 to 6 inches. Small-diameter machines are designed for manufacturing hosiery. The architecture of these machines differs from standard circular knitting machines above all from a technical point of view, but also for considerable differences in the type of available accessories.

Knitting (double cylinder): A circular knitting machine with two cylinders, one superimposed above the other. It is equipped with one set of double-ended needles that can be caused to knit in either cylinder as required to make plain, rib, and purl knitted structures. This arrangement is commonly used in hosiery knitting machines and garment length knitting machines.

Knitting machine (circular): A knitting machine in which the needles are set radially or in parallel in one or more circular beds. Used without further classification, the term generally refers to a weft knitting machine of this type.

Note: Machines with diameters less than 165 mm are often termed smaller diameter machines.

Knitting machine (hosiery): A knitting machine for the production of hosiery. Most are small diameter latch needle circular knitting machines.

Knitting machines (garment length): A knitting machine adapted for the production of individual garment panels, in series, rather than for continuous

production of fabrics. The term is most commonly used to specify this type of circular weft knitting machine.

Knitting notation: It is a simple, easily-understood, and symbolic representation of a knitting repeat sequence and its resultant fabric structure that eliminates the need for time-consuming and possibly confusing sketches and written descriptions.

Knitwear: Garments made out of knitted fabrics.

Knock-over position (knitting): The new yarn is drawn through the old loop, thus new yarn produces a new loop. If knock-over position is shifted vertically, stitch length can be changed.

Knops (knots): (1) Symptom of a fault – caused by knots or knot-like thickenings due to inextricably entwined fibres;(2) Yarn effect – in the form of dot-like or knot-like thickenings, fluffy places, etc., in slub yarns;(3) Weaving effect – as the V- or W-weave loop formation in pile fabrics (pile loops); also similar in pile carpets;(4) Denepping – removal of unevenness in fabrics (knots, spun-in wool flock, curls, trapped pieces of thread, etc.) using tweezers and fabric relaxation. The dyeing of undyed or off-shade dyed weaving points using so-called retouching pencils, this occurs after weaving or before or after wool scour.

Knop yarn: Same as nub yarn in England.

Knopp work: Framework knitting, with two sets of needles and Jacquard attachment, which regulates the accumulation of loops on certain needles and thus forms the design.

Knot: A joining by tying together.

Knot breaking force (in tensile testing): The breaking force of a strand having a specified knot configuration tied in the test specimen portion of a strand mounted between the clamps of a tensile testing machine.

Knot breaking load: It is a deprecated term. Use the preferred term – Knot breaking force.

Knot breaking strength: Strength expressed in terms of knot breaking force.

Knot density: Slub or knot density, number of knots, or slubs in relation to 1 m² of an oriental carpet. Top quality pieces contain up to 1 million; normal material 50000–500000; cheap pieces only approximately 15000 knots or slubs.

Knot (long) in raw silk: Knots, which have loose ends from 3 to 25 mm in length. See **Long knot**.

Knot (type ‘O’): One in which the bight is below, the bight crosses over the right hand end.

Knot (type ‘U’): One in which, when bight is below, the bight crosses under the right hand edge.

Knot (very long) in raw silk: Knots, which have loose ends exceeding 25 mm in length. See very long knot.

Knotted laces: Made in Italy, Dalmatia, etc., by tying lengths of thread into knots by the hands, the knots forming patterns like the macrame.

Knotted work: Laces made by knots; either tatting or macrame.

Knots (1): Used to join ends of yarn or thread together. Most textile companies use “weavers” knots, or air splices. Most knots will cause the thread to break but most air splices will sew through the needle without breaking. There are many types of knots – single weaver’s knots, double weaver’s knots, tension knots (for the connection of threads coming from opposite directions, e.g. broken ends), cats head knots (connection of parallel threads).

Knots (2): There are two kinds of knots forming the pile in oriental rugs, one is the *Turkish or Ghiordes*, the other the *Persian or Senna* (see). The fineness of the rug is judged by the number of knots to a square inch.

Knottling: A process used for macrame, fishing nets and carpets.

Knottling(in weaving): If a new drawing-in operation is not necessary (this expensive operation is avoided whenever possible) because no style change is needed, the warp is taken from the beam store and brought directly to the weaving room, where it is knotted on board the loom to the warp prepared with the knotting machine.

Knottling machine: See **Knottling (in weaving)**.

Knotted carpets: Pile carpets created by the knotting of brightly coloured threads in a warp system. With the exception of weaving technology, the oldest and most common process for the manual production of carpets. We differentiate between Persian and Turkish knots. See **Oriental carpets**.

Knubbs: In England, the very closely woven, hard and fine inner layer of the cocoon; used for waste silk. See **Frisons**.

Knuckle (in zippers): See **Crimp (in zippers)**.

Ko: Coir fibres.

Ko Hemp: Very durable, soft, fine and silky bast fibre yielded by the *Pueraria thunbergiana* in China, India and Japan; used for summer clothing fabrics.

KOB: Abbreviation for children's outerwear.

Kokura: A hand-woven Japanese cotton fabric made in plain or twill weave and comes in five varieties, all having ribbed effect.

Kokura Hanaoji: A hand-woven Japanese cotton fabric made of ply yarn, with weft cord effect. In weaving, three or four warp ends are drawn through one heddle. This cloth is cut into strips, rolled and sewn together to form cord for the Japanese clogs.

Kokura Kabanji: A cotton duck made on handlooms in Japan, mostly ply yarn being used and weft cord effect produced; used for trunk covers.

Kokura Obiji: A hand-made Japanese fabric, made of silk warp and cotton filling or of all-cotton with weft cords. It is usually plain woven and comes mostly in dark blue with a single plain or ornamented stripes; used for sashes by the natives.

Kolinsky mink: See **Mink**.

Kompon: A plain woven, stout linen in China; used for garments by the natives.

Konieh rugs: Heavy all-wool rugs made in Asia Minor, the medium long pile is tied in Ghiordes knot. Many of the old samples have a hexagonal field and rich colours. Modern K. rugs have a great variety of colours. The sides and ends are finished with a selvage.

Konje: Native African name of the bowstring hemp fibre.

Koomach: Cotton cloth in Russia, usually dyed bright solid red and also indigo or green; used for blouses, women's dresses, etc.

Kora cloth: Colloquial name Greige fabric in India.

Korako: Native name for the New Zealand flax, yielding fibres suitable for fine fabrics.

Kordofan gum: Gum Arabic.

Kotonin: Cottonized flax.

Kotzen: Rugs and laprobes, made in Austria of coarse goat's hair with a very long hair on both sides.

Koujong: Very soft, fine, twilled woollen, made in China.

KP: Kapok.

Kracher: Thick and knotty points in yarn.

Kraft pulps: Pulps prepared in the alkaline liquor consisting of sodium hydroxide, sodium carbonate, and sodium sulphide. Also called sulphate pulp.

Kraft yarn: A yarn made by twisting a strip of paper manufactured from kraft pulp. See **Yarn kraft**.

Kraftcord: This yarn produced by tightly twisted plant fibre is sometimes used in carpet backings.

Krätzen: More or less sharply limited points in hosiery after dyeing, at which hosiery stitches are more dense and irregular, presumably points which, due to bagginess during the fixing of the raw material, did not lie close to the hosiery form and therefore had inadequate tension.

Kron: The best sort of Russian flax. Kuba Oriental all-wool rug, having a long and fine pile in light colours.

Kronos titanium white: Titanium dioxide (from Norwegian ilmenite) in different types with varying TiO_2 content (up to 98%). Chemically barely corrodible, unchanging white with maximum covering effect. Used for printing dyes, delustring, paints.

Kroy shrinkproofing process: Continuous process for shrink proofing wool tops in which there is a direct chlorination step with no intervening chemical reaction followed by anti-chlorination and neutralization. Provides better hand and strength than do conventional shrink proofing.

Kubleka Munk value (K/S): Describes the optical properties of a coloured sample as a double constant made up of K = light absorption (absorption constant of dyes) and S = light dispersal (determined by textile material). If K/S values for the maximum absorption wavelengths are displayed logarithmically as a function of the dyestuff concentration C , then in the ideal case this produces a straight line with a gradient of 45° , with dyeing or printing errors, for example, showing up as measuring points that deviate from the straight line. Calculated using the formula $K/S = (1-B) / 2B$, where B = luminosity coefficient.

Kulah rugs: Prayer rugs from the Turkish city of Kula. Velvety smooth pile, approximately 150000 knots per m^2 . The large red or blue prayer niche is framed by a border with stylised, often tiny flowers. The *masarlikula* (cemetery kula carpet) is a special type.

Kulkan: Richly brocaded silk shawls, made in Persia, similar to the cashmere shawls.

Kumbi: Soft and silky seed fibre of the *Cochlosper mumgossypium*, a tree in India; used for stuffing.

Kurbelstickerei: German term for machine embroidery, the design being of tape over a net ground; used for curtains.

Kurdistan rugs: (1) Coarse and rough rugs, made in Mesopotamia of all-wool with a heavy, long and loose pile tied in Ghiordes knot. Dark coloured natural wool is often used. The ends are finished with braided fringe; (2) Fine all-wool rugs made in Persia, the close short pile is tied in Ghiordes knot. The pattern consists of small figures covering the field of a conventionalized blossoming tree or a diamond shaped centre medallion in blues and reds. The end selvages contain one strand of coloured wool.

Kuriwata: Japanese trade name for ginned raw cotton.

Kurk: Fine soft wool, yielded by a species of white goat in Persia; used for shawls which are finished with a hairy back.

Kurrijong: Dark, tenacious bast fibre yielded by a species of the *Commersonia* in New South Wales; used for nets.

Kusters dyeing range: Continuous dye range for carpets. The unit wets the carpet, applies dyes and auxiliary chemicals by means of a doctor blade, fixes the dyes in a festoon steamer, and washes and dries the carpet in one pass through the range. An optional auxiliary unit may be installed to randomly drip selected dyes onto the background shade for special styling effects. This process is called TAK dyeing.

Kyrle: Fancy woollen yarn; used for various overcoatings and dress goods.

Kz: Cashmere.

L

‘L’ Designation: The sequence number given each AATCC Blue Wool Lightfastness standard according to the number of AATCC Fading Units required to produce a colour change equal to Step 4 on the AATCC Gray Scale for Colour Change.

L*, A*,B*

La: A very strong and light mat, made of the leaves of the pandanus in the Tonga Islands: used for sails.

Label printer: A small flat-film printing machine for textile tapes or fabric patterns to be subsequently cut. Different types are used in a thermal print process, either single-coloured textile labels or multicolour, wash fast, and printed on one or both sides.

Labile complex: An unstable (liable to change) coordination compound.

Labrador blue: The dark blue of the mineral labradorite. The most common colours of labradorite are blue and green although it can also display gold, red, pink, purple and bronze.

The marvelous display of colour is caused by light reflected from the unique spacing of the planes of crystals often producing a three-dimensional image. See **coloured gems**.

Laboratory sample, in wool top: Portions drawn from the lot in accordance with the described procedure.

La uie: Large plant, similar to the pandanus. The leaves are used by the natives of Samoa for clothing mats.

Lac: A fairly fast orange or crimson dye yielded by the dried bodies of the coccus laccae, an insect living on flag trees. It was used formerly as mordant dye, but is very little in use now.

Lace: Open width fabric of various constructions and elaborate designs. Any fibre may be used but the most common are now nylon, viscose and cotton. Made as edging as well as wide-width fabric, it is with few exceptions, machine made. Narrow lace is used flat, pleated or gathered as decoration, wide lace is mainly used for lingerie, night wear, formal dresses, such as wedding outfits. Cheaper varieties are sometimes used as curtains and bed spreads.

Lace bark: Yielded by the *Lagetta lintearia* tree in Jamaica. It is a fine thin lace-like bast; used for dress trimmings, hats, also for cordage.

Lace, bobbin: Bobbin lace is a kind of plaited structure made from 4 to 400 bobbin yarns. The yarns are worked into a pattern by twisting and crossing the threads. The pattern is outlined by pins stuck in a pillow. The lace may be formed directly on the pins or may be pinned to the pattern on the pillow as it is formed. Also known as pillow lace. Well known examples are laces of Brussels, Chantilly, Antwerp, and Valenciennes.

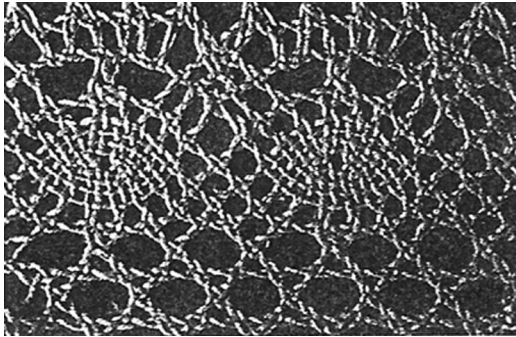

Bobbin lace

Lace, embroidery: Embroidery lace is made by hand or machine application of embroidered patterns to a base fabric. After the pattern has been embroidered, the base fabric may be wholly or partly removed, either by cutting or by using burned out technique.

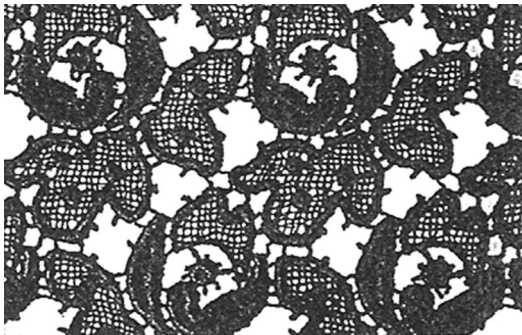

Embroidery lace (burnt out)

Lace, Raschel: Raschel lace is made on a warp knitting machine with latch needles. Most handmade laces can be pretty well imitated on a warp knitting

machine. Machine made laces are now much more common than hand made because of the volume and cost advantage over bobbin laces.



Raschel lace

Lace cloth: A sheer and light fabric, woven of fine yarn in leno or mock leno weave; used for dresses, etc.

Lace galloon: This is a fine, delicate copy of the genuine Valenciennes lace on the weaver's lace machine. Knitted ribbons of this type are called galloons. Chiefly made of cotton but also containing a small proportion of polyamide for strength.

Lace machine: The Machines for manufacturing Lace. See **Lace making**.

Lace making: Simultaneous braiding (interlacing) and twisting of threads (yarn, twist) in a diagonal direction for the manufacture of laces, small covers and similar items. These are classified into handmade lace (lace pillow), which in terms of quantity no longer has any significance, and machine-made on lace making machines. In the last case, the bobbins travel around each other in the warp sheet.

Lace stitch: In this knitting stitch structure, loops are transferred from the needles on which they are made to adjacent needles to create a fabric with an open or a raised effect.

Lace Tweed: Very light-weight Raschel-knitted fabrics made of natural silk, crêpe or polyamide warp. The bulky, roving or even wadding-type weft material is predominant and covers the warp (spun thread fine support structure). No qualitative requirements have developed.

Lacklustre, lack-lustre: Lacking in brightness or lustre. See **Dull**.

Lacquer-black: A glossy lustrous black colour as in '*Madonna with long lacquer-black tresses*' (*The Evening Standard* 1.2.99).

Lacquer printing: Local gloss print chiefly produced in film printing using film (hole) screens, on thin fabrics and in Rouleaux printing (Chintz prints).

Matt to high gloss effects are achieved with a certain degree of relief effect (depending on the thickness of the metal screen which ranges from approx. 0.3–1 mm).

Lace work: Open work hosiery.

Laced running stitch: Embroidery stitch. Running stitch can be laced with a contrasting colour to form a decorative border. Use a pointed needle for lacing and do not pick up any of the fabric.

Lacet: (1) Silk or cotton braid used to form patterns for laces, and, (2) Lace made of such braid.

Lacets bleu: French couil (see); used for trousers.

Lacis: Name for darned netting in the 15th century.

Lacquers: In most cases substances soluble in volatile solvents which form a thin, adherent, continuous film on the substrate by evaporation or physico-chemical processes. Lacquers are classified according to their composition as follows: (a) Oil- (resin) lacquers: Not used extensively now, these are the oldest type of so-called “long-oil” varnishes with resin (e.g. mix of copal, linseed oil, oil of turpentine) or without resin (e.g. so called enamel lacquers for white internal and external coatings consisting of oil of turpentine, zinc white, boiled linseed oil, and wood oil additive). (b) Cellulose lacquers: First among these are the different high-gloss collodium lacquers corresponding to the oldest type of so-called zapon varnishes (made from dissolved collodium wool or cheap film-formers or celluloid in amyl acetate) and pure nitro lacquers (nitrocellulose dissolved in ethyl or butyl acetate etc. diluted with toluene etc.) used in lacquer printing and in pigment and bronze printing etc. Plasticizers are used as softeners. (c) Synthetic resin lacquers: among these are, for example, phenolic resin lacquers made from phenolic plastic, spirits and another solvent, either as a so-called stove enamel (where infrared drying at 90–150°C follows curing) or “cold cure” lacquers with the later addition of very dilute acid (used as wood lacquers in particular).

Lactic acid: $\text{CH}_3\text{CH}(\text{OH})\text{COOH}$; MW 90. Used as a wool mordant, in the manufacture of numerous dye mordants, as a substitute for tartaric acid and citric acid (leads to the softening of textiles to produce soft, silk handle without weakening the fibre or lustre), as a dye solvent (diphenyl and aniline black pad dyes) and in aniline-black dyeing (aniline lactate), leather dyeing and finishing and for spotting agents, etc.

Ladder: Stitch Used in embroidery and made by running parallel or zigzag bars over an evenly wide space or by working the bars on the material to imitate the rungs of a ladder.

Ladder: See **Run**. Appearance of a flaw in weft knit fabrics, especially women's hosiery. Arises as a result of a wale or wales having been mechanically undone or opened following thread breakage, where in addition to the stitch originally affected, those stitches connected to it also become undone in succession.

Ladder braid: Open work braid, made similar to a ladder; used for laces and for trimmings.

Ladder tape: Stout cotton tape; used for Venetian blinds.

Ladder web: A crochet warp knitted narrow fabric consisting of two wales or columns of stitches spread apart by the width of the slat of the Venetian blind. Weft yarn crosses from one wale to the other from a ladder like structure which separates and positions the slats of the blind. Knitted ladder web is usually made from polyester yarn and headset after manufacture.

Ladder proof finishes: (snag and ladder proof and antisnag finishes). Treatment of knitted fabrics usually made from fine yarns, and stockings against laddering and snags. Antisnag agents are used for this purpose. They are applied during exhaustion or spraying processes.

Ladies cloth: A fine, wide, wool flannel, slightly napped, similar to broadcloth.

Ladik rugs: Small, all-wool rugs, made in Asia Minor; the weft is coloured; the short and close pile is tied in Ghiordes knot. Scarlet red and white are often used. The ends are finished with a red selvage.

Ladines: Eighteenth century woollen fabric in England.

Lagos: Variety of African cotton having a moderately strong and coarse staple of brown colour and very irregular in length.

Lahore: (1) Knotted cotton and wool rugs made in India. The design consists usually of alternate rows of palm leaves; (2) English dress goods, made of cashmere wool.

Laid fabric: A fabric made without filling yarn, the parallel warp yarns being held together by means of rubber latex or other binding material. See **Fabric laid**.

Laid-in Fabric: A knit fabric in which an effect yarn is tucked in, not knitted into, the fabric structure. The laid-in yarns are held in position by the knitted yarns.

Laid-in yarn: See **Axial Yarn**.

Laid work Embroidery, consisting of couching.

Laine: French for wool.

Laine brodee A two-fold yarn, made of an open and firm Australia wool, and used as weft in genuine Beauvais and Gobelin tapestries.

Laine de Carmenie: Persian goats' hair.

Laine elastique: All-wool, dull black, light French dress goods made in crepe and corded effect.

Laine de terneaux: Variety of French merino wool.

Laisot: Strong French linen canvas of good quality, made 48 inches wide.

Laizes: French laces, consisting of a clear net ground and powdered patterns, in dots or small flowers.

Lake, lac: A dark-red crimson resin deposited on certain trees and plants by the insect *coccus laccae* (possibly *laccifer lacca*) originally used as a dye or pigment or glaze. (Compare **cochineal** and **kermes**). The term has for many centuries come to designate any insoluble compound of organic matter produced from plants, vegetables, coal-tar or clay which absorbs colorant and is used to produce pigments of many different colours with a high degree of translucency.

Lake: Fine medieval woollen fabric; used flexible bast fibre, yielded by an Indian shrub, and used for ropes.

Lama: Plain or twilled flannel-like French woollen lining with a slight nap; comes in plain colours or stripes.

Lama-barchent: In Germany and Austria, a very softly finished cotton fabric woven with two sets of filling threads of different colours, one forming the face and the other the back and napped on both sides.

Lambsdown: A plated knit cloth, the face made with very heavy and spongy fleece raised from slack twist woollen yarn, while the back is of hard spun cotton; used for children's coats, carriage robes, etc.

Lambskin: A very closely woven cotton fabric, made in an eight-leaf, weft face satin weave, containing a very large number of picks. The fabric has a woolly nap raised on the face; used for working clothes.

Lamb's wool: Soft resilient wool shorn from lambs upto seven months old. Usually used for knitwear and in small amounts, mixed with other fibres in fabrics.

Lamé: French for "trimmed with leaves of gold or silver" Made with silk or any textile fibre in which metallic threads are used in the warp or the filling. The main fibre of the fabric can be silk, viscose, acetate, triacetate, nylon or polyester also. Lamé is also a trade mark for metallic yarns.

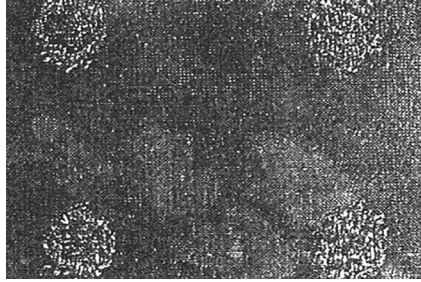

Usually a figured weaves but could be any. Often has pattern all over the surface. The shine and glitter of this fabric makes it suitable for dressy wear. The term comes from the French for “worked with gold and silver wire”. The fabric is thin and drape well. Uses: Principally for evening wear.

Lamellar macromolecule: In crystalline areas (in the plane of the paper), the structure of two-dimensional or lamella macromolecules in the sense of so-called chain grids (Pleated sheet structure), for example, in the case of cellulose (lamella), wool (keratin grates), synthetics (crystallite) and silk.

Lamella: (1) A thin leaf or disc. (2) The term membrane lamella is used in fibre histology, for example, in the case of cellulose fibres and synthetic polymers. The two-dimensional system consisting of cellulose chains arranged in parallel and bonded to each other via hydrogen bonds represents the building block for the three-dimensional *Micelle*.

Lamella separator, lamellar plate clarifier, tilted plate separator: A settling device with parallel, steeply inclined plates, about 50 mm apart.

Lament: A Highland tartan, composed of the following colours; *Dark green stripe; white stripe, measuring less than half the width of the green dark green stripe, repeated ; black stripe, as wide as green; stripes of dark blue, black, dark blue, black, each as wide as white one; dark blue stripe as wide as green; stripes of black, dark blue, black, dark blue each as wide as the white; black stripe, as wide as the green; repeat group described above between two *; black stripe, as wide as green one; dark blue stripe, as wide as green one group of three stripes, black, blue black, each as wide as white; blue stripe, as wide as green; black stripe, as wide as green.

Lametta: Thin metal thread used in brocades.

Laminar flow: Streamline flow in a viscous fluid, such as molten polymer, near a solid boundary.

Laminated fabric: A layered fabric structure wherein a face or outer fabric is joined to a continuous sheet material, such as polyurethane foam, in such

a way that the identity of the continuous sheet material is retained, either by the flame method or by an adhesive, and this is in turn normally, but not always, is joined on the back with a backing fabric such as tricot. See Fabric, laminated.

Laminated fabric, in fabric roof systems: A flexible material composed of superimposed layers of textile fabric firmly united by bonding or impregnating with an adherent polymeric material to one or more surfaces.

Laminates: Laminated materials. Made of foam backed fabric, where the fabric is usually inexpensive acrylic jersey, a nylon or acetate jersey and sandwiched between the two, a thin layer of synthetic foam. The layers may be stuck together by adhesive or more usually, all three are passed through a machine which applies flame on both sides of the foam to melt it. The three layers are then pressed together. Used for children's clothes, women's jackets etc.

Laminating: Bonding together of two or more layers of similar or differing flat textile materials such as woven, knit goods, films, felt, paper, nonwovens, fleeces and foam films.

Laminating calendar: This is used to bond textile or paper webs by hot-melt spray coating or with thermoplastic films.

Laminating carpet: Term formerly used for Bonded-pile carpets.

Laminating technology: Bonding textile materials with other non-textile flat materials such as paper and plastics. Techniques:

- (a) Adhesive is applied to one laminate component in the form of a paste (coating process), powder (powder point coating process) or melt (roller melt process) and this is pressed with a second or third component.
- (b) The surface of a foam is melted using a flame and pressed onto a textile material (Flame laminating).
- (c) A (foamable) thermoplastic is first applied to a carrier such as paper (release paper) or continuous metal band and released at the moment of bonding (transfer or reverse process). This process can be used to produce very thin coatings. The flame laminating process, using thermoplastic foams, is widely used, for example, in the manufacture of car upholstery.

Lamot: Native Philippine name for Manila hemp.

Lamparillas: All-wool or linen or silk warp, lightweight fabric in solid colour, stripes, or figures, made in Flanders in the 18th century.

Lampas: Originally a fabric from India, (East India) was a printed silk fabric, similar to brocade. But nowadays the name is given to a woven fabric with a rep ground and a satin like pattern formed by the warp yarns. A contrasting effect is achieved, too, with the weft yarns so that the same colours appears in the pattern as in background. Very elaborate designs are be produced. It is a heavy fabric, usually made of cotton, iscose, acrylic, or mixtures now. Used for curtains, and furnishings.

Lampas du Japon: Rich French silk brocade, made with warp ribs; used for dress goods, drapery, etc.

Lana del tambor: A Venezuelan silky seed hair, grown on a species of the Bombax tree; used for stuffing.

Lanameter: An instrument used for measuring fibre fineness including that of chemical fibres. It consists of a desk-shaped housing which has a diagonally arranged measuring matt disc upon which the fibres magnified 500 times are projected. The thickness measurement is accurate to within 0.001 mm.

Lance: Clip-spot (fr: lancer = to throw)A term applied to fabric with an associated group patterning (figuring). This is formed by a second warp and/or weft system in which threads interlace with only a few warp threads at intervals across the fabric and float over or under the rest of the warp threads

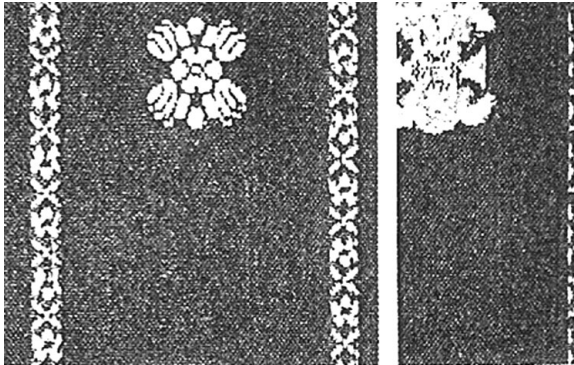

to produce tiny dots or spokes on the ground. The patterning only appears in stripes even if the pattern itself shows no stripe arrangement. The threads not required for patterning on the face float or are woven in at points on the reverse (in contrast to Broché).

Lances: General French term for fabrics in which certain of the filling threads are crossing only a number of warp threads, floating for the rest.

Lanella Fleece: Name for a fibre prepared from a grass; it is carded with shoddy and used for cheap clothing.

Langely: A unit of total solar radiation equivalent to one gram calorie per square centimeter of irradiated surface. NOTE: The internationally recommended units are: Joule (J) for quantity of radiant energy, watt (W) for quantity of radiant power, and meter squared (m²) for area. The following factors are to be used: 1 langely = 1 cal/cm²; 1 cal/cm² = 4.184 J/cm² or 41840 J/m².

Lanilla: Hard worsted serge of medium quality on the western coast of South America.

Lanolin: Purified wool grease, chiefly a mixture of cholesterol esters. It is used in salves, cosmetic, grease paints, and ointments.

Lanometer: (Rapid Lanometer) – instrument for testing the thickness of fibres, particularly wool. The total cross-section of 100 parallel bundled fibres is measured using a special caliper. Dividing the measurement by 100 gives the average fibre thickness. See **Lanameter**.

Lansdown: Soft dress goods made with silk warp and worsted filling in a three harness twill weave.

Laos: Silk crepe, made with raw silk warp and tussah filling, the latter being alternately two picks of right hand twist and two picks of left hand.

Lap: A continuous, considerably compressed sheet of fibres that is rolled under pressure into a cylindrical package, usually weighing between 40 and 50 pounds. The lap is used to supply the card.

Laps: Loops are termed '*laps*' in warp knitting because the warp guides lap their yarn around the needles in order to form the loop structure. The loops (overlaps) may be open or closed.

Lap splitting: A condition caused by a lap that will not unwind in carding in the same thickness as it was wound in picking. This splitting of the sheet of fibre can result in either a thicker or thinner sheet being fed into the card.

Lap waste: See **Waste, lap**.

Lap, Asbestos: A flat compressed form of carded or otherwise felted asbestos fibre with or without carrier fibres.

Lap, closed, in warp knitting: *Closed laps* produced when a subsequent underlap goes in the opposite direction to the preceding overlap, thus lapping the same yarn around the back as well as around the front of the needle.

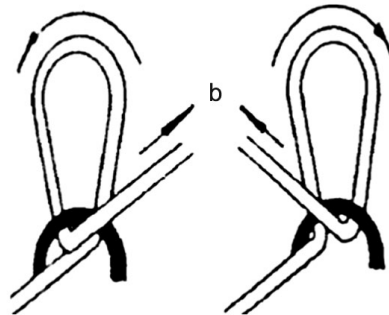

Closed Lap

Lapel: The upper part of the front edge of a Jacket or coat which holds back on to the fore part. The length of the lapel extends from the gorge seam to the break.

Lapel roll: The fall and the curl of the lapel downwards from the break seam of the collar to the first button. The term 'roll' applies chiefly to a soft finish lapel, not one which is pressed almost flat on the crease line.

Lapel seam: The seam caused by sewing the back edge of the lapel strip to the front edge of the fore part becomes the "lapel-seam".

Lap-felled seam: A seam formed with the edge of both plies of material concealed by interlapping. Two or more rows of stitches secure the turned pieces of material.

Lapidary blue: A brilliant blue.

Lapis lazuli: A bright blue; also 'lapis lazuli blue'. A mineral used from the 13th century to make ultramarine. For many years the only known deposit was in Badakhstan in Afghanistan. Its vivid blue is the result of its sulphur content. See **Ultramarine**.

Lapped seam: A complex seam formed on the inside of the object with both raw edges enclosed, and having one visible line of topstitching on the face side and a small fold formed by the topstitching. Used for yolks and applied pieces like gussets, where one section of the garment is lapped over the other for sewing.

Lapped seam: In the lapped seam the edges are folded each within the other or one over the other so that both sides are alike. If made of heavy material, the raw edges are left unturned; in muslin or linen the edges are in turned, lapped, basted and the hem stitched on both edges or hemmed down on both sides by hand.

Lappet: See **Ballooning eye**.

Lappet: A woven fabric with patterns, usually geometric produced by floating threads on the right side of the fabric. These floats are not so long. An example is a zig-zag stripes in white yarn on a coloured plain weave ground. The techniques are also used to form woven spots, produced by cutting the floating yarns between the spots. Any fibres including mixtures are used in this type of fabric.

Lappet weaving: A process of decorating plain woven or gauze fabrics with embroidery-like effect simultaneously with the weaving of the ground. The pattern is formed by an extra warp thread, heavier than the ground, trailing in the direction of the filling.

Lapping: A term describing the movement of yarn guides between needles, at right angles to the needle bar, or laterally in relation to the needle bar, or laterally in relation to the needle bar during warp knitting.

Lappings: Used for iron printing cylinders in roller printing. These can be made from ramie or viscose in the warp and wool in the weft.

Lard: Lard is the soft, white fatty deposit found in hogs. The best grade is called leaf lard and is used for frying foods. The difference between lard and tallow is the presence of the polyunsaturated linoleic acid which is responsible for the softer physical state. The fatty acid composition is 43% oleic, 10% linoleic, 27% palmitic and 14% stearic acid.

Large repeat prints: Large repeat printed articles are on the one hand the Sari and sarong of traditional Far-Eastern ladies' clothing and traditional clothing of the black African population and on the other, table cloths, bed linen, curtains, terry towels, ready-to-wear patterned ladies' outer clothing, flags and printed carpets.

Large Repeat Rotary Screens: These combine the advantage of a high print speed offered by the rotary screen with that of a large format offered by the flat screen. For reasons of stability, the perimeter of the screen can only be increased to 2 m. They are used for printing table cloths, carpets, deco fabric and clothing materials with special patterns.

Larkspur: The pale greenish-blue colour of the plant of the same name; a colour in Winifred Nicholson's '*Chart of Colours*' 1944.

Lase: An acronym for load at specified elongation: the load required to produce a given elongation of a yarn or cord.

Laser: A device for producing an intense beam of coherent light. It is used for cutting, spectroscopy, photography, biomedical investigations, etc.

Abbreviation for “Light Amplification by Stimulated Emission of Radiation”, i.e. light amplification by excited emission of radiation. The laser is an instrument for producing very small, concentrated spots of high-intensity light.

Laser screen engraving: An electronically controlled diamond tipped engraving tool is used to engrave/apply the design to the screen directly at high speed and with high precision. The edges of the burnt out holes are sharply contoured and are sealed by the singeing and melting process. The lacquer used for this purpose is not related in any way to the original photosensitive lacquers and can be selected from an existing range of the most durable lacquers (even self-cross-linking).

Lash-In: See **Jerk-in**.

Lashed-In filling: See **Pulled in filling**.

Lashed Pile: Weft pile fabrics, the pile picks interwoven with three warp ends after each float. This secures a fast pile.

Lasting: A narrow and very stout English worsted, woven with double or three-ply warp, and single filling in a five-leaf satin weave; used for shoe tops.

Lastrile fibre: (1) See **Rubber**. (2) A manufactured fibre in which the fibre-forming substance is a copolymer of acrylonitrile and a diene composed of at least 10% by weight, but not more than 50% by weight, of acrylonitrile [-CH₂-CH(CN)-] units (FTC definition). Lastrile fibres are fibres formed from copolymers of acrylonitrile and a diene such as butadiene and contain 10%-50% acrylonitrile units. Lastrile fibres have not been commercially produced. The major proportion of butadiene within the copolymer suggests that the fibre would have extensive elastomeric character.

Latch needle: One of the two types of knitting machine needles. The latch needle has a small terminal hook with a latch that pivots automatically in knitting to close the hook. The fabric loop is cast off. The latch then opens, allowing a new loop to be formed by the hook, and loop-forming and casting-off proceed simultaneously. (Also see **Spring Needle**.)

Latent acids in Dp finishing: Ammonium chloride, amine hydrochloride are used to cure U / F and M/F resins when fast, low temperature curing is wanted. Disadvantages are fabric pH is acidic. Ammonium salts give rise to trimethyl amine, fish odor.

Latent crimp: Crimp in fibres that can be developed by a specific treatment. Fibres are prepared specially to crimp when subjected to specific conditions, e.g., tumbling in a heated chamber or wet processing.

Lateral: A descriptive term for a textile fibre composed of two or more polymers at least two of which have a continuous longitudinal external surface.

Lateral holding strength: The force required to disengage a snap fastener resulting from a pull in the plane parallel to the material to which the snap fastener is attached.

Lateritious, Latericeous: Brick-red.

Latex yarns: Yarns extruded from latex, elastic rubber yarns (Rubber fibres) that are subsequently vulcanized.

Latex: The raw material from which natural rubber is made. It is used to produce stretch yarns, but is of less importance after the introduction of spandex.

Latile: A grass; used for fine braids, etc., by the natives of the Solomon Islands.

Lattice braid: Same as **Ladder braid**.

Lattice stitch: In embroidery, slanting bars are run across a long, narrow, open space, forming latticework.

Lattice-Tulle : The name of a knitted or fine woven curtain with regular lattice-structure. Also named raschel tulle. The dimension stability of Tulle is not very good.

Lauhala: Fine mats, made of pandanus leaves by the natives of Hawaii; used for covers.

Launderability, in buttons: Ability of a button to undergo multiple cycles of launderings without damage such as cracks or loss of finish.

Laundering: A process used to refurbish a textile products or parts thereof by (1) cleaning it in water containing a cleaning agent, and possibly bleach, (2) drying it, and (3) usually ironing or pressing it.

Launder-o-meter: (wash-O-meter) A standard laboratory device for testing a cloth's colorfastness to, and shrinkage in, washing and dry-cleaning. An american standard washing machine consisting of a heated boiler with motorised drive for using 10–20 screw-on bottles (500 ml capacity and 42 rpm) that contain 15 steels balls (6 mm dia) to mechanically manipulate the test samples during testing. This apparatus is especially recommended for laundering and milling durability testing but is also used as a wet fastness testing and HT dyeing machine.

Laundry: Industrial plant (large-scale plants are usually of industrial form) normally engaged in the Washing of Laundry.

Laundry marker: Textile markers (inks, pencils, ballpoint pens, and marker pens) especially designed for the laundry and dry cleaning, with appropriate practical durability but easily removed in case of spotting.

Laurel: A dark yellowy green.

Lauric acid: $C_{11}H_{23}COOH$. Component of coconut oil, laurel oil and sperm oil. Among other things, used for the manufacture of textile auxiliaries such as detergents.

Lava-red: An intense orangey-red.

Laval: Various French linen fabrics.

Lavena: Fine, lightweight woollen dress goods of natural colour.

Lavender: Pale lilac; having the colour of lavender flowers; also lavender grey and lavender blue. Possibly derived from the Latin *lavare*, to wash. Referring, particularly in the US, to homosexuality – see the **Lavender List**.

Laventine: A thin silk used for sleeve linings.

Lawn: (1) The name lawn derives from the name of Laon, France, where it was made first. A very fine smooth fabric. It is lighter in weight than cambric, may be bleached, plain dyed or printed, and has a slightly stiff finish which may be permanent. It is a plain-weave fabric made from cotton or linen and is cool and absorbent and hard-wearing. A typical texture is 72 x 60 with 45s warp and 60s weft, using carded cotton yarns. Fine lawns can be made with combed 70s for warp and 90s weft. Spun synthetics are also used instead of cotton. Lawn is crisper than voile but less crisper than organdy. A very popular fabric for women's summer dresses, baby clothes, blouses, nightwear, underwear etc.

(2) Bleached linen, cotton or half linen fabrics with a linen finish. Mainly used for regularly washed articles.

Lay: See **Lea**.

Lay: (1) Plaiting down a fabric is called laying. It can be a free plaiting as happens in most of the processing machines or can be a precision laying as in the cases of garment production laying for panel cutting.

(2) It can be a set of laid fabric for a purpose.

Lay out, in designing: The arrangement motifs in the framework of the design frame.

Lay out, in sewing: Lay out, in sewing is the cutting chart on the pattern instruction sheet that shows placement of the pattern pieces on the fabric.

Lay, Direction Of: See **Direction of twist**.

Lay-on-air stenter: An air control system for the fabric running in parallel to the fabric pathway and using a combination of slit and jets.

Lay-on-air stenter: An air control system for the fabric running in parallel to the fabric pathway and using a combination of slit and jets. Two fans in a vertical shaft with changeable direction of flow. These ventilators, in each field, allow an over and under-flow of air to be split through regulating flaps to control the air flow. The fabric is carried by the stream of hot air emerging from the jets without the aid of any additional guiding mechanisms.

Laying: (1) The doubling process in manufacturing ropes.

(2) The process of forming a lay. See **Lay**.

Lazouri lake: A blue pigment.

Lazy Kate: The device used to support full bobbins while plying. A fairly traditional design, involves two vertical posts that support the bobbins. Rather like a free-standing ladder. Another form, favored by Schacht, has the bobbins supported horizontally with the addition of a breaking cord to control the backspin. Now, Alden Amos favors a vertical support with the addition of leather washers to help slow down the backspin. At this time, there is no image available.

LC50, LD50: The lethal concentration (LC) or lethal dose (LD) at which 50% of the organisms die when exposed to that concentration or dose of the substance. The exposure time is short at 48 hours or sometimes 96 hours. It is also known as the TLM (median tolerance limit) or MLD (median lethal dose).

LC-50 and LD-50 values: These parameters are used to describe the lethal concentration (Lethal limit) of toxic substances. The acute toxicity is given as the average lethal dose (50% of tests) in mg/kg live body weight for oral toxicity (LD-50) and as the lethal concentration in mg/l for inhalation toxicity (LC-50).

LCP: Short form for Liquid Crystal Polymer.

LDPE: Low-density polyethylene; See **Polyethylene**.

Lé: French carpet-width measurement unit. 1 lé =approx. 70 cm.

Lea, in cotton yarns: The number of 120 yard lengths of yarn over pond; an indirect yarn numbering system.

Lea, in linen yarns: The number of 300 yard lengths of yarn per pound; an indirect yarn numbering system.

Lea, in worsted: A length of 80 yards per pound; an indirect yarn numbering system.

Lea: (1) Measure for wet spun linen yarn; it means the number of 300 yard (274.32 m.) cuts that weigh one pound. Twelve leas make a hank, 200 leas or 16 & Half hanks make a bundle. See cut and yarn number. (2) A skein used for yarn strength tests. The skein contains 80 turns each 1 & half yards (137.16 cm) in length (A.S.T.M.). (3) Also represents a unit of length in reference to other fibres and varies: 120 yards (109.73 m) of cotton yarn, 120 yards (109.73 m) of spun silk and 80 yards (73.15 m) of worsted.

Lea count constant: See **Break factor**.

Lea product: See **Break factor**.

Lea skein: A skein of length and circumference specified for the specific yarn numbering system involved commonly to determine the linear density and strength of yarns.

Lea strength: Tensile strength giving the no. of lbs tensile load required to break 1 lea of a particular yarn.

Lea Test: Skein strength test (fibre-bundle tensile strength).

Leachate, percolate: When water passes through a *landfill* it becomes contaminated with various organic and inorganic pollutants. This wastewater is known as leachate. Leachate generation occurs once the absorbent characteristics of the waste are exceeded. The leachate contains material dissolved from the landfill including Na, Cl and sulphate. Organic material in the landfill biodegrades to simpler organics which may be washed out in the leachate giving a BOD of several thousand mg/l. Some of the organic nitrogen in the fill decomposes to ammonia and the ammonia content of the leachate can be several 100 mg/l. Ferric compounds in the fill are reduced to more soluble ferrous ions and leachate may contain 100 to 1500 mg/l of Fe. The leachate also contains suspended solids and it has a brownish colour. As the organic material in the fill becomes more stabilised, the contaminants in the landfill decrease and the BOD reduces to less than 100 mg/l. The ammonia and iron content of the leachate also reduce substantially as the fill ages.

Leaching: The removal of any substance or dye from textiles by the percolating action of a suitable liquid.

Lead: The colour of the metal lead, particularly in the form used for roofing purposes.

Lead-blue: A greyish blue.

Leader: This is the length of yarn attached to the center core of a bobbin or shank of a spindle to aid in starting your yarn.

Leader cloth: Fabric used to lead the production fabric the machine. Leader cloth is usually a part of the machine. When production cloth has to be started it is stitched on to the leader cloth and run through the machine and taken out. When the machine is to be stopped it is stitched again to the end of the production fabric and left on the machine after the production fabric has been removed at the delivery end of the machine. In jig, it is cheap fabric which is used as the first layer on the jigger and also in drying and steaming and other continuous processes to lead the piece goods. Often made from polypropylene (low dyeability and economic). See **Back grey**.

Leader mark: See **Decatizing mark**.

Leaden: A dull grey colour.

Leaf-green: Having the colour of leaves; sometimes the yellowy-green of young leaves. One of the colours in the **Ostwald circle**.

Leaf fibres: Sub-group of Hard fibres in the form of woody fibres and vascular bundle components from the leaves or leaf sheaths of numerous sub-tropical plant species (such as sisal and manila). Fibre extraction by manual or mechanical methods; fibre preparation by rotting often produces poorer qualities.

Leaf stitch: Embroidery stitch Bring the thread through at the stem point and make a sloping stitch to the one side of the leaf. Bring the thread through at the other point of the stem joining the leaf (next to the first point and make a sloping stitch to the other side of the leaf.

Bring the thread through at point next to the second point on opposite side of the leaf, then continue working alternate stitches on each side in this way until the shape is lightly filled.

When this stitch is used there is usually an outline of Stem Stitch or Chain Stitch worked round the shape.

Leamington Axminster: Small size machine-made Axminster rugs in light colours for bath rooms.

Lean: Wool with a harsh handle; spins unsatisfactorily.

Leas Ties: Also known as lees ties and lease ties. This is such an interesting term that pops in and out of textiles. I asked a longtime weaver which was correct. She said it wasn't so much correct but where you learned to weave. The fact that a term used in measuring linen yarns is "lea" makes me think leas ties came from that direction. So what are they? They are the short threads tied around hanks of yarn to help keep them from tangling while being washed,

dyed, and stored. They are also the short threads tied around a warp to allow you carry it from the warping board/mill to the loom. They serve the same process of keeping the threads in order. They are tied by running a thread at right angles to the warp/hank and interweaving through and coming back at opposite angles. Kind of a series of sideways figure 8's.

Lease rods: See **Lease sticks**.

Lease sticks: Lease sticks are two rods or flat sticks longer than the width of the warp. They are placed in the openings of the cross. The cross is maintained in the space between the lease sticks, keeping the threads in order for threading or slewing.

Lease, Weaving: A lease in a warp in a loom at the rear of the healds which is maintained by two traverse or lease rods, often oval in cross section.

Leasing: The renting of capital commodities and long service items or industrial plant by lease financing or lease-purchase agreements. Used increasingly as an alternative means of finance in the textile and finishing industries.

Leasing reed, in sectional warping: A leasing reed forms the shed into which the strings which separate odd from even threads are inserted. To permit this operation, the leasing rod frame is knocked over and two deflection bars bring all the threads to same level. The odd reed dents are interrupted by welding spots, whereas the even dents are completely practicable; the downwards reed movement permits to the welding spots to drag the odd threads downwards. This way the shed for the insertion of the first lease cord is formed. In a second stage the comb moves upwards, dragging the odd threads upwards; thus the second cord can be inserted into the new shed.

Leasing rod frame: A leasing rod frame is one which during warping separates the threads into various layers, so that they can go through the subsequent expanding comb without mutual crushing. It serves also to create the room necessary to insert the leasing strings for the sizing operation.

Least count, in tensile testing: The smallest change in the indicated property that can customarily be determined.

Leather: The hide or skin of animals prepared by Tanning. The thickness and type varies according to the source.

Leather cloth: A coated, light calico cloth, elastic and waterproof for table cloths and the lining of hats, etc.

leather brown: The brown tan colour of shoe leather.

Leather tanning: A high degree of stabilisation of the leather structure is achieved through the bonding of chrome to carboxylic acid groups, thus

forming so called binuclear chrome complexes between two carboxylic acid groups of the amino acids in the collagen structure. The stability is so high that the collagen fibres are resistant to boiling. The process is termed collagen tanning and it is this which turns hide into leather.

Leavers lace / Calais lace: A generic term for laces made on Leavers machine. Used for curtain this fabric is a very finely patterned Tulle-lace. Today this material can be perfectly produced on Lace-Raschel machines. Fibres used are : Polyester, Polyester/Cotton blends, Polyester/Acrylic blends. Limited dimension stability, hanging-out is possible. If cotton is used, shrinkage may occur during household washing.

Lechuguilla: Fibre yielded by the plant of same name growing wild in Mexico. The fibre is very strong, coarse and is used for bags, ropes, etc. Also called ixtle.

Ledra: Embroidered quilts made by the natives of Jharkhand, India. See **Kanthas**.

Leek-green: The green of the vegetable of the same name; sometimes an olive green. See **Prasinous**.

Left hand twist: Any single or ply yarn, the final twist of which is from right to left.

Left twill: Any diagonal twill, running to the left.

Left handed twill: See **Twill, left handed, Left twill**.

Leghorn: The yellow colour of straw; from Leghorn in Italy (now Livorno) which produced a particular kind of wheat from which Leghorn straw hats and bonnets were made. The straw when harvested was green in colour, but was bleached before being used.

Legs, in Zippers: The two portions of a separate element that affix the element on the bead.

Lehriya: Striped turban fabric made in Rajasthan, India. It is composed of harmoniously arranged diagonal stripes, they were originally dyed in yellow and red and used for turbans made for Rajput community of Rajasthan. The lehriya was also patronized in the nineteenth and 20th century by Marwari merchant class of Rajasthan, who wore turbans of multicoloured lehriya fabric, mostly featuring pachranga (five coloured) design, considered auspicious because of the special position of number five in the Hindu mythology. The satranga flaunts the seven colours of the rainbow. Unidirectional stripes are known as lehriya, while the diagonal stripes intersecting at right angles to form checks are the Mothra.

Leicester: Good English wool, spinning about 40s to 44s yarns. The staple is very lustrous, light and long.

Leisure: In England the selvage of velvets and silks.

Leisure wear: Style of clothing which, in comparison to the so-called conventional-classical clothing, is designed more to meet the user's requirements and place more emphasis on comfort with light fabrics and a casual style with the trend of fabric compositions towards synthetic mixtures and ease of care; used for shirts, ladies' suits, dresses, men's jackets, trousers, suits and trouser suits.

Lemon: A vivid yellow; the colour of the outer part of the fruit of the same name.

Lemon Chiffon: One of the colours in the **X11 Colour Set**. It has hex code #FFFACD.

Lemon chrome: A brilliant yellow pigment.

Lemon yellow: A strong yellow composed in a number of different ways one of which includes strontium nitrate

Length analyzer: An instrument which determines the upper-half-mean length and length uniformity index of a test beard of cotton.

Length of lay: The length of one layer of the fabric laid on the cutting table. In the CAD based cutting, the lay length is decided by the software to get the maximum efficiency in cutting taking into consideration of all the sizes of the garment and the packing ratio of different sizes of the garment.

Length, Bending: See **Bending length**.

Length, Breaking: See **Breaking length**.

Length distribution, of staple fibres: A graphic or tabular presentation of the proportion or percentage (by number or by weight) of fibres having different lengths.

Length distribution, of fibres: A graphic or tabular presentation of the proportion or percentage (by number or by weight) of fibres having different lengths.

Length, of a Fabric: The distance from one end of the fabric to the other measured parallel to the side edge of the fabric while it is under zero tension and it is free of folds or wrinkles.

Length, effective fibre: See **Effective fibre length**.

Length group: All fibres, or pulls, whose length fall within a given length interval.

Length interval: A class interval of 3mm (1/8 in.) usually designated by its midpoint length in odd numbered sixteenth of an inch.

Length, Mean: See **Mean length**.

Length of lay, in steel cords and strands: The actual distance required to make one 360° revolution in any element in a strand or cord.

Length of tear, in fabric: The measured distance propagated by a tearing force from the initiation of the force until its termination.

Length, traverse: See **Traverse length**.

Length, skein loop: See **Skein loop length**.

Lengthwise direction, in textile: The direction in a machine made fabric parallel to the direction of movement the fabric followed in the manufacturing machine.

Leno: (1) Leno is the name given to the structure made when the weft is passed between warp ends or a group of ends that have been twisted around each other before the shed is made. The leno weave produces an open-textured fabric that may be sheer or heavy. It is produced by the doup attachment to the basic loom. The doup attachment controls the warp threads horizontally as well as vertically and the unusual warp interlacing prevents slippage of the filling and reduces shrinkage. Examples include mosquito nets, household bags and curtains.. Most often, the designs formed in leno fabrics are stripes, which add textural interest.

(2) Light weight cotton or silk fabrics, having two sets of warp, crossing' each other in the weave; used for dresses, waists, etc. See **Marquissette**.

Leno crepon: A fabric comprising of a cotton crepon background cloth with leno-weave style embroidery may be white or in a contrasting colour and it is usually worked in stripe formation. Used for blouses, shirts and dresses.

Leno fabric: (àjour fabrics, filigree work, gauzes), in most cases, transparent fabrics with Gauze weave, leno weave such as àjour fabrics, etamine, net curtain fabrics, gauzes, marquissette and similar weaves; also used for fashion effects in dress and blouse fabrics.

Leno voile: A plain-weave cotton voile fabric with an open, leno drapy fabric. Used for children's clothes, blouses and nightwear.

Leno weave: A weave in which two adjacent warp yarns cross each other between the picks. This type of weave gives firmness and strength to an open weave fabric and prevents slippage and displacement of warp and filling yarns.

Leontine: French silk dress goods, made with two-ply warp in white, blue and black colours.

Leopard: A buff-coloured, short-haired, flat fur, with black rosette markings. Very hard wearing.

Leslie: Highland tartan, consisting of the following: Wide dark green stripe; narrow black stripe; wide dark green stripe; very fine white line; black stripe, made a little narrower than green one; dark blue of same width as the black; red stripe, as wide as black between the green ones; dark blue stripe repeated; wide black stripe repeated; fine white line.

Let-off: This motion delivers warp to the weaving area at the required rate and at a suitable constant tension by unwinding it from the weavers beam.

Let off mark, in woven fabrics: A corrugated defect pattern distributed across the fabric width. Let off marks are caused by badly adjusted let-off motion in a loom.

Let-off motion: A device for controlling the delivery and tension of the warp during weaving.

Lethal concentration (LC): Constituent concentration estimated to produce death in a specified no. of test organisms in a specified time period (eg., 96-h LC_{50}).

Lethal index: Concentration of a Poison in mg/m³/min. required to lead to the death of an adult fish.

Lethal limit: Lethal limit for poisons: LC-50 and LD-50 values; Death rate for fish in effluent. See **LC-50** and **LD-50 values**.

Lettuce green: The yellowish green colour of lettuce leaves.

Leuco: Leuco refers to vat dyes in the reduced form; in general a prefix meaning white. Vat dyes are converted from the insoluble pigment form to the soluble leuco dye form by means of a reducing agent and an alkali, often sodium hydrosulfite and sodium hydroxide. Sulfur dyes are also converted to leuco form for application. Once on the fibre, the leuco form is converted back to the insoluble pigment by oxidation. In spite of the formal definition of leuco as a prefix, dyes are often still coloured in the leuco form (for example, leuco indigo is yellow-green).

Leuco compounds: Water-soluble colourless reduction compounds, for example, vat and sulphur dyes, in aqueous and alkaline liquors (Vat) that are fibre substantive and are rendered insoluble through oxidation to become fixed in the fibre.

Leuco sulphur dye: Powder-form of (Sulphur dyes) which already contain the reducing chemicals necessary for solution and dyeing. Applied without the addition of sodium sulphide. No longer commercially available.

Leucorhodina: A medieval silk fabric of very pale pink colour.

Levant red: See **Turkey red**.

Levantine: A stout twilled silk, each side finished equally but of different colours.

Levantine pour: Leaf, double-faced, closely woven silk serge, having single or ply warp. Comes mostly in solid colours, but also in stripes.

Level: Uniform in shade over the surface of a piece of dyed fabric or along the length of dyed yarn Level dyeing is usually the objective in commercial processes. Some dyes, such as leveling acid dyes, are easy to accomplish level results with. They do not bind tightly to the fabric in the dye bath, and dye can leave the fibre and re-enter the dye bath. Other dyes, such as reactive dyes, don't level as easily, and greater care is required to achieve level results. In general, level dyeing is promoted by good agitation, careful control of the rate of rise of the temperature of the dye bath, control of pH, and sometimes by use of special leveling agents or *retarders*. It is often the case that the dyes that level most easily are the least *washfast*.

Level loop: A term describing a tufted or woven carpet with uncut, equal length loops composing the pile surface.

Level pile, for pile yarn floor coverings: Pile in which all tuft legs are of substantially same length.

Levelling: (1) The process of correcting an uneven dyeing to an even dyeing by any suitable process. There are auxiliaries/chemicals available which can help in the migration of dye from a higher concentrated area to a lower concentration area to make the dyeing level. There are also other technic of making the dye migrating to the dye bath and redepositing. Sometimes the process in which an unlevel dyeing is completely stripped and new dyeing is done, is also called leveling in a processors point of view even though in technical point of view it is not leveling.

(2) Migration leading to uniform distribution of dye in a dyed material. Leveling may be a property of the dye or it may require chemical assistance.

Levelling acid dye: A class of acid dyes Leveling acid dyes typically offer bright colours and level easily. Unfortunately, the same property that makes it easy to get level results causes wash fastness that is not as good as that of many other acid dye classes. Leveling acid dyes are often used for wool.

Levelling agent: A dye bath additive to promote level dyeing; see **Retarder**.

Levelling capacity of dyes: Levelling properties; also the ability of a dyestuff to cover differences in exhaustion onto a substrate. The property of the dye, on the fibre, to migrate from a site of higher concentration to a site of lower concentration. The levelling capacity is dependent on time, temperature and additions of electrolyte and auxiliaries.

Levelling dyes: General term for acid dyes with outstanding levelling properties for dyeing wool.

Levelling roller, sectional warping: The levelling roller permits to carry out the warping under low thread tension, and to attain at the same time a compact winding. When processing mono-filament or multi-filament yarns in fine counts which do not stand high compression, it is possible to cut out the levelling roller.

Levelness: This term is used to describe the uniformity of distribution of a finishing substance on and within goods after a particular treatment.

Leviathan: (hebr. liwiathan = giant), continuously operating plant for washing loose wool which is sluiced through 5–7 wash vats (2500–4400 l capacity) by means of (fork, drag and shake) rakes in accordance with the pass-on principle.

Leviathan canvas: Coarse, open canvas used for embroidery. At felled seam

Leviathan stitch: Called also Railway stitch; used in embroidery. It is composed of three long stitches next to each other crossed by a fourth in the middle.

Leviathan wool: Thick, soft wool yarn for embroidery.

Levi's Redwire DLX iPod Jeans: The international American brand Levi's has added a music player on their symbolic blue jeans in contrast to tops where you are more likely to find music player items (Comprehensive Merchandising Support 2007).

L/H: Abbrev. denoting an aqueous Emulsion, for example an oil (Gk.: lipos) in water (Gk.: hydro) system.

LI: Flax (linen).

Liage: French term for an extra warp which binds the extra brocade weft thread.

Liberty: (1) Originally an East Indian tussah silk cloth, printed in Europe; (2) Light, pliable and highly finished silk fabric; used for dresses, trimmings, etc.

Liberty print, lawn: High quality, light weight, plain woven cotton fabrics made with fine or very fine yarns. Printed and lightly stiffened for dresses and blouses.

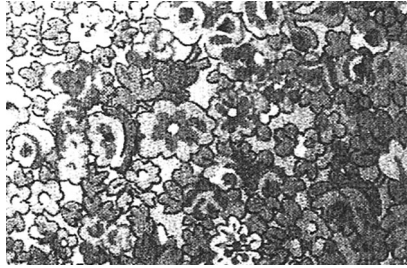

Lichen-green: The whitish-green of the lichen plant.

Lickerin: A part of the feed mechanism of the card. It consists of a hollow, metal roll with a spirally grooved surface containing a special saw-toothed wire. The lickerin opens up the tufts of the picker lap as it is fed to the card and transfers the fibres to the main cylinder.

Lickerin loading: A condition whereby fibres are imbedded in the lickerin wire clothing so as to resist transfer to the cylinder clothing.

Lienoillo: Gray cotton goods in South American countries.

Lienzo: Unbleached cotton sheetings and shirtings in Argentina, Paraguay and Uruguay.

Lif: Name for the fibre yielded by the leaf stalks of the date palm in Arabia and Africa; used for ropes, coarse cloth, etc.

Lifting plan: An indication of the order in which the heald shaft are lifted on each pick in one weave repeat. Also called Peg plan or Chain plan.

Light: (1) Electromagnetic radiation of which a human observer is aware through the visual sensations that arise from the stimulation of the retina of the eye. This portion of the spectrum includes wavelengths from about 380 to 770nm. Thus, to speak of ultraviolet light is incorrect because the human observer cannot see radiant energy in the ultraviolet region. (2) Adjective meaning high reflectance, transmittance or level of illumination as contrasted to dark, or low level of intensity.

Light (colour): (1) Lightness. (2) Term used for classification according to “white and pastel shades”.

Light cabinet: Colour-matching cabinet.

Light damage: See **Photochemical fibre degradation, yellowing of textiles.**

Light edges: See **Edge-to-edge unevenness**.

Light end: See **Fine end**.

Light end: The low boiling fraction in distillation.

Light fading: Exposure to light, through photochemical reactions, causes damage to dyeings; recognizable as changes in the colour tone.

Light fastness: A measure of how resistant a coloring material, such as dye, is to fading due to exposure to light. There are a number of textile industry standard methods for valuating how lightfast dyed fabric is. Differences in the light fastness of individual dyes mixed to make a specific colour can result in a colour shift over time as the dyes of lesser fastness fade while others fade much less. Light fastness mostly depends on the molecular structure of the dye itself, but can be influenced by the fibre or contaminants.

Light filling: See **Thin filling**.

Light pick: See **Thin filling**.

Light sensitivity: See **Photochemical reactions**.

Light source: An object that emits light or radiant energy to which the human eye is sensitive. The emission of a light source can be described by the relative amount of energy emitted at each wavelength in the visible spectrum, thus defining the source as an illuminant. The emission also may be described in terms of its correlated colour temperature.

Light weight duck: See **Duck**.

Lightness: Perception by which white objects are distinguished from gray, and light-coloured objects from dark-coloured.

Ligne: A unit of measure for buttons, one ligne equals 0.635 mm (0.025 in.)

Lignin: A mixture of natural aromatic organic compounds found in woody and grassy plant material. Lignin occurs in bast fibres such as linen. Lignins are normally removed from fabric to be dyed, since they may dye easily but with poor fastness. Lignins extracted from wood pulp used to make paper are used to make some types of surfactants.

Lilac: The pale purple colour of lilac blossom. See **Anil**. Pertaining to lesbianism; See **Lavender**.

Lille lace: A bobbin lace, the earlier specimens have straight edges, the patterns being outlined with a heavy cordonnet, the hexagonal ground is a very light and fine mesh, each mesh having two sides made of a single thread and four sides of two threads twisted together. A very fine textured bobbin lace, with patterns outlined in thicker threads, characterized by a dotted design. Resembles Mechlin Lace.

Lima: Raw cotton from Peru; the staple is rather coarse and harsh.

Limbacher Artikel: (simplex knit), suede-type finished knitted fabric made from cotton, used for gloves in particular. Strong alkali treatment is used to achieve a more compact structure.

Limbaki: A synthetic fabric for swimwear which has a pile.

Lime: the green or yellowish green of the fruit, lime.

Lime-baryta process: Water softening process used where there is a high level of sulphate hardness and high permanent hardness. Degree of softening up to approx. 1–2°.

Lime blue: A moderate blue.

Lime green: A greenish yellow or olive colour; a pale green.

Lime soap: Lime soap is produced by the displacement principle converting soluble Na stearate soap into insoluble Ca stearate soap (lime soap) according to the following equation:

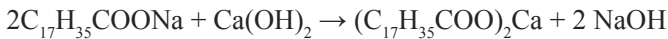

109.3 g sodium stearate soap is converted into lime soap by 10 g CaO which corresponds to 1 m³ water at 1°.

Lime-soda boil: A method of scouring cotton. In this process the fabric is boiled with milk of lime which convert the fatty acid into insoluble lime soaps. The lime soap is then converted into free acids on acidification and calcium is washed away as calcium chloride. The deposited free acid is then converted to soluble soaps on subsequent boiling with sodium carbonate. This method is tedious and not economical as two boils are required to remove the natural impurities.

Lime soda process: Lime water softening process

Lime water: Calcium oxide.

Lime water softening process: Oldest method used for precipitating out hardness salts with calcium hydroxide; also used for de-acidifying water (stoichiometric amounts). Softening is possible up to around 2–4° depending on the non-carbonate hardness. Not very suitable for water with a high chloride content as this increases the solubility of calcium carbonate.

Lime wool: Skin wool, (slipe wool) obtained by de-hairing, i.e. by separating the wool from the skin by hydrolysis using calcium carbonate, sodium sulphide. Results in wool which is generally damaged.

Lime yellow: A medium yellow or greenish yellow.

Limestone: A brownish grey colour.

Limerick lace: An Irish hand- or machine-made lace, in which the patterns are embroidered on to the net with a darning stitch. This is a fine lace.

Limiting oxygen Index: A relative measure of flammability that is determined as follows. A sample is ignited in an oxygen/nitrogen atmosphere. The oxygen content is adjusted until the minimum required to sustain steady burning is found. The higher the value, the lower the flammability.

Limiting quality level (LQL), in acceptance sampling: The fraction of non conforming items at which the process average can be considered barely tolerable; the process average at which the risk of acceptance is called the Consumers risk.

Limerick Lace: Irish needlework, executed either by stitching patterns with heavier thread over machine made net ground or by buttonholing the edges of the pattern traced over lawn or muslin, cutting away the ground and applying the whole on machine made net.

Limoges: (1) coarse French bagging made of strong hemp yarn; (2) a cotton and linen cloth, made in coloured stripe for beds in Switzerland; (3) an obsolete French guipure lace.

Lin du pays: Trade term for dew retted flax from Premesques and Beaucamps, France.

Lincere: The finest linen fabrics in ancient Greece, made with double warp and single filling.

Lincoln: Lustrous and thick English wool, used for yarns from 38s to 40s.

Lincoln green: A yellowish green colour being the colour of cloth of the same name and associated with Robin Hood and his band of outlaws.

Linden green: A greenish yellow.

Lindsay: A Highland tartan, made as follows: Wide rose coloured bar, split in the center with a pair of very narrow, dark blue lines; dark blue stripe about one-fifth the width of the rose bar; dark green bar, slightly narrower than rose one, split with a pair of dark blue, narrow stripes near each edge, these stripes being spaced from the edge and from each other their own width; dark blue stripe, about one-fifth the width of the rose bar.

Line: (1) Name for hackled flax, which is numbered either as warp numbers (for fine dressed line), the numbers, ranging from 25 to 100 indicating the lea of a fair warp yarn which can be spun of that line. With the other numbering, used in Scotland, the number indicates the pounds per spindle of 14,400 yards of yarn; dressed line is a thoroughly hackled flax; (2) Standard of measurement for the width of ribbons, being 1-11 inch; (3) The rib on the braid.

Line Flax: Line flax is the long flax fibre that has been drawn off of the hackles. The finest preparation is often used for wet-spun linen, but line can also be dry spun.

Line Fleece: A fleece of wool midway between two grades in quality and length, which can be thrown into either grade.

Line yarn: Linen yarn spun from the longer flax fibres; spun up to 300 leas.

Linear density: Mass per unit length expressed as grams per centimeter, pounds per foot,

or equivalent units. It is the quotient obtained by dividing the mass of a fibre or yarn by its length.

Linear integrator, in textile unevenness testing: An integrator that operates continuously and reports the unevenness for a certain, and unchanging, time past.

Linear lea: An indirect yarn numbering system in the linen spinning system equal to the number of 300 yard length per pound.

Linear Polymers: These are the polymers where monomeric units are linked together to form long straight chains. The polymeric chains are stacked over one another to give a well packed structure.



Linear chain

As a result of close packing, such polymers have high densities, high tensile strength and high melting points. Common examples of these type polymers are polyethylene, polyester and nylon etc.

Linear pressure: This refers to the pressure per cm of roller length in the nip of two press-rollers.

Lined work: A twill, made by the symmetrical combinations of the broken diamond twills, like the bird's eye.

Linen: Yarn, thread, or fabric made from flax fibres.

Linen: A very strong yarn of high lustre made from flax fibres. The resulting fabric is also called linen. The yarn can be used for all types of weave and all weights of fabric from fine lawn to suiting and house hold furnishing.

Linen, birds eye: See **Birds eye linen.**

Linen, butcher: See **Butcher Linen**.

Linen canvas: Tailors close, even weave beige coloured canvas of excellent quality. Used in men's coats in conjunction with hair canvas. It is also called Holland or Flax canvas.

Linen checks: Blue and white striped or checked all linen cloth; used for dresses and aprons.

Linen fabrics: Fabrics made of the fibres of the flax.

Linen-look: Fabrics made to resemble plain-weave linen suiting, which were developed when linen became very expensive for dress wear. They have the typical uneven slub yarn and a crisp even finish. Most have a crease resist or crease recovery finish applied to them. The fibre content may be 50% cotton with remaining polyester or they may be mainly viscose fibre. Used for shirt-waister dresses, trousers for men and women.

Linen numbering systems: The systems for numbering linen yarn are:

In Scotch, dry spun yarn one spindle (or spangle) contains 2 hesps, or 4 hanks, or 24 heers, or 48 cuts, or 5,760 threads, or 14,400 yards.

In Ireland and England 1 bundle contains 16 2-3 hanks, or 200 cuts, or leas, or 24,000 threads, or 60,000 yards. In Austria one schock contains 12 bundles, or 60 pieces, or 240 hanks, or 4,800 cuts, or 288,000 threads.

The Dorset and Somerset system takes the weight of 21,600 yards (called "dozen" or 12 half hanks).

In France the paquet contains 360,000 yards.

In Belgium the paquet contains 180,000 yards.

According to the numbering based on the metric system, the number gives the kilometres (1,000 metres) of yarn contained in one kilogram (2.2 pounds).

Linen twill: A twill fabric made of linen in light weight and usually used for embroidery.

Linen union: Linen union is smooth or figured fabrics (tablewear) made from flax (tow) and cotton yarn, in either warp or weft.

Linen weave: Same as plain weave.

Linen yarn: Spun of flax fibre. Dry spinning, employed in Scotland, gives a very strong yarn.

Linoleum: A floor covering made on burlap base. Oxidized linseed oil is mixed with ground cork and other pigments. This composition is rolled over the burlap base. It comes in plain, printed or inlaid. The plain has a uniform surface in one colour; printed linoleum has patterns printed in colours; inlaid

has patterns of different coloured compositions which go through to the burlap base lining the flax fibre is first macerated in hot water, which separates the fibre into its short, ultimate components; this is used for the fine counts.

Linnet: A French-make lining fabric of unbleached linen.

Lingerie knit: A very wide tricot fabric of all weights which is easy to sew. 'Power net' is a two-way stretch fabric used for foundation garments.

Lining: Material used to cover part or all of the inside of a garment.

Lining: A lining fabric can be made from silk, viscose, acetate, triacetate. Polyester etc. The fabric suitable for lining are either plain weave, satin or twill and they are usually slippery to enable the garment to be put on and off with ease. Some fabric like acetate is cheap but not durable, others like silk or polyester satin or pongee is more durable.

Lining fabric: Fabric that is used to cover inner surfaces, especially when the inner surface is of a different material than the outer. May refer to garment lining, lining for boxes, coffins, etc. Generally of smooth, lustrous appearing fabrics, but also of felt and velvet. Both manufactured fibres and natural fibres are used.

Linittest: Wash fastness tester which can also be used as a laboratory dyeing machine; can also be used for HT-dyeing.

Linizing: Permanent finish to make cotton fabrics look like linen e.g. with strong caustic and cuprammonium solutions whereby the fabric surface is partially dissolved and subsequently coagulated.

Link-and-link: See **Purl**.

Linked processes: Refers to the connection of the various steps of fibre-to-yarn processing via pneumatic fibre-transport systems, on-line monitoring, and process control. Process linking results in less labor-intensive processing. A typical linked system might include all stages from bale opening through carding.

Linking: A sewing process used to attach knitted trimmings to body pieces by chain stitching individual stitches to the body.

Links-links fabric, purl fabric: Knitted fabrics which only have purl stitches visible on both fabric faces. The purl stitch courses conceal the adjacent plain stitches, as can be seen in the crosswise extension of the fabric.

Linon: Plain and closely woven fine, very light, glossy, washable cotton or linen fabric; used for dresses, waists, etc. It comes in white or solid colours. It is the French for lawn.

Linon a jour: A gauze-like linen fabric used as dress goods.

Linnoxyn: Linseed oil is (air) oxidised and polymerized to form a thin, transparent, skin, e.g. by the oxidation of (linseed-) oil size

Linseed oil: Linseed oil is high in linoleic (60%) and linolenic acid (25%). These oils will polymerize through the double bonds to form hard lustrous finishes on wood. Their major uses are as wood and furniture finishes and in oil based paints.

Linsey: (1) A term used to describe any waste or rags containing wool.

(2) A coarse fabric with a cotton warp and a blended yarn of cotton and waste wool for the weft. The weave is plain twill, usually in stripes across the width. Used for aprons and overalls.

Linsey-Woolsey: A fabric no longer made or used; it was a cheap, coarse cloth of wool and cotton or linen.

Lint: The main seed hair of the cotton plant. A form of waste; Fibre fragments aggraded from textile materials; also loose short fibres or fluff.: An inherent fault in silk only apparent after degumming or dyeing. It is characterised by fine fibrils of fibrillae that become separated from the filament, so giving a speckled, disheveled appearance.

Lint ball: See **Fuzz ball**, **Balling up**.

Lint content: That portion of a mass of cotton fibre consisting of fibre, including normal, moisture content, but excluding foreign matter.

Lint cotton: Loose cotton fibres in any form, either raw or processed, free of seeds, and not bound together in yarn or faric.

Lint doctor: In roller printing, the Doctor blade removes excess print paste, the lint doctor is located on the opposite side of the printing roller, behind the printing surface formed by the roller and printing cylinder, to remove excess print paste left on the roller after printing. This prevents the print paste from contaminating the following fabric.

Lint, In loose cotton: Fibres mostly of spinnable length.

Lint, ginned: See **Ginned lint**.

Linters: The short fibrous material adhering to the cotton seed after the spinnable lint has been removed by ginning and which is subsequently recovered from the seed by a process called delinting.

Linthee: A Chinese silk taffeta.

Linton tweed: See **Tweed**.

Lipases: Used in desizing to improve the removal of fats/oils of animal and vegetable origin even at temperatures at which the fatty materials are in solid form. To remove triglyceride-based size lubricants from fabrics.

Lipophilic groups: Lipophilic groups are molecular groups which have an Endophilic reaction in an organic, non-gaseous phase.

Lipophobic groups: Lipophobic groups are molecular groups which have an Exophilic reaction in an organic, non gaseous phase.

Liquid ammonia treatment: A process using anhydrous liquid ammonia (Sanforset) has been commercialized for stabilizing Denim fabrics. Smooth drying ratings and reduced residual shrinkage were improved without losses in strength and abrasion resistance. The improvement was not to the level one would expect of durable press but enough to warrant the expense. A variation of this process has also seen commercial usage. Cotton shirting fabric was passed through the liquid ammonia process and then topped with a low level of DMDHEU. The DP performance was higher than if the resin had been used alone. The losses in strength and abrasion were minimized by the low level resin treatment. The liquid ammonia process involves passing the cotton fabric containing a controlled, low level of moisture into a pad bath of liquid ammonia. The ammoniated fabric is put through a Palmer unit and removing the ammonia while the fabric is pressed flat against the drum.

Liquid crystal: A liquid in which the molecules are oriented parallel to each other resulting in birefringence and interference patterns visible in polarizing light.

Liquid crystal Polymer: Polymers such as aramids or the thermotropic polyesters that form liquid crystals when in the appropriate state, (concentrated solution or melt). Most liquid crystal polymers have in their structure a succession of para-ring structures. The liquid crystal formation is thought to relate to the fact that there is a limiting concentration of rod-like chains that can exist in a random arrangement in a solution or melt. Once this concentration is reached, ordering or alignment of the chains is necessary to accommodate them. Fibres from liquid crystal polymers generally have high modulus and tenacity, good chemical resistance, and high temperature resistance. They are used in a wide range of applications including protective apparel, tire cord, composites, ropes and cables, etc.

Liquid dyes: Liquid paste. Easy to handle, simple to measure, therefore well-suited for automated yarn dyeing and continuous plant. Formulation of Dyestuff.

Liquefied natural gas (LNG): Liquid methane, obtained from natural gas and used as a fuel. See **methane**; **Natural gas**.

Liquefied petroleum gas (LPG): A mixture of liquefied hydrocarbon gases (mainly propane) extracted from petroleum, used as a fuel for internal combustion engines and for heating.

Liquor ratio (or liquor to goods ratio): The ratio of the weight of the dyebath or other processing bath to the weight of the goods being dyed or processed. For immersion dyeing in art dyeing processes, a common liquor to goods ratio is 20:1. That is, for each kilogram of fibre to be dyed, 20 kilograms of dyebath are used. In the metric system, this is easy to calculate, since one litre of water weighs one kilogram. High liquor ratios are generally avoided, since they often cause poor exhaustion of the dye, though this is not true for all dye types. Modern commercial dyeing equipment often works with low liquor ratios. Very low ratios may be used for methods where essentially all of the dye solution is to be absorbed by the fibre, such as padding.

Liquor: A solution of dye and/or other chemicals.

Liquor goods ratio: Liquor-to-goods ratio: The ratio of goods (kilograms) to liquor (litres), defined more precisely as: the ratio of the dry weight in kg of the goods, including all associated materials, measured immediately prior to the finishing process, to the volume in litres of the entire treatment liquor in the system at a temperature of 20°C at the time of the measurement.

Liquor level: Either the level or the quantity of liquor contained within a dye bath, etc.

Liquor pick up: See **Pick-up**. The amount of liquor picked up by the fabric in any process. The pick-up of liquor in the pad mangle is dependent upon:

- the squeezing pressure of the squeezer,
- the textile material,
- composition of the pad dyeing liquor,
- temperature of the dyeing liquor,
- throughput speed of the goods.

Liquor quantity: Liquor-to-goods ratio.

Liquor ratio: See **Liquor goods ratio**.

Liquor stability: The physical and chemical resistance of dyeing and other treatment liquors.

Liquor wedge: It arises in both horizontal and vertical broadloom washing machines between the guide roller serving as principal washing element (a) and the travelling sheet of fabric (b), i.e. shortly after the installed spray pipe

(c) which constantly applies a film of liquor to the fabric. As a consequence hydrostatic pressure builds within the liquor wedge and forces liquor through the fabric.

Lirelle: Trade name for a polyester fibre developed by Courtauld's high degree of wet strength. It is used alone or mixed with other fibres as cotton.

Liro- (G): Pale.

Lisardes: (1) An East Indian and Persian cotton cloth; (2) A coarse Egyptian linen cloth.

Lisere stout: French silk cloth made with weft brocaded flowers and Jacquard figures with the warp.

Lisiere: French for selvage.

Lisle: This fabric, now superseded by finer synthetics, was a knitted material made from mercerized cotton yarns. Originally made in France, it was used in large quantities for women's stockings before the invention of nylon.

Lisle: Hard spun thread, made of long staple, combed cotton, the yarn is gassed and is used for hosiery and underwear.

Lisle yarn: A high-quality cotton yarn made by plying yarns spun from long combed staple. Lisle is singed to give it a smooth finish.

Lisse: (1) French for warp; (2) A silk gauze used for dresses.

List: The selvage.

Listed: Fabrics having damaged selvage.

Listing: An uneven dyeing effect in which there is a variation in colour between that of the selvedge and that of the centre of a piece-dyed fabric.

Listing: Same as **Tailing**.

Listones: Silk and velvet ribbons in Latin-America.

Litmus: A blue pigment obtained from lichen used as an indicator in solution or by colouration of paper. A distinction is made between red litmus paper, which reacts to an alkali by turning blue, and blue litmus paper, which reacts to an acid by turning red. Its neutral colour is violet.

Litre: (typically spelled 'liter' in the U.S.A.) Symbol: l. Fluid measure, i.e. spatial or volumetric measurement equal to 1000 cm³ of water at 4°C and standard pressure, which equals 1 l or 1000 ml. On this definition, one liter is the same as 1000.028 cubic centimeters. One litre is approximately 1.06 US liquid quarts, or 0.88 imperial quarts. One litre of water weighs, for practical purposes, 1 kilogram.

Litt: Medieval name for dyed fabric.

Liuse: Chienyong Scarlet red cut silk velvet from China.

Livery: The dress or uniform of servants.

Livery Cloth: See **Boxcloth**.

Livery tweed: Very strong and durable whipcord tweed, made of wool in England. Used for uniforms and liveries.

Livid: Bluish; black and blue; lead colour; pale. A word with a history of shifting meanings.

Originally indicating black and blue (the colouring of bruising) from the Latin *lividus*, but used to designate many other colours including lead-colour; grey; ashen; blackish; and purple. Possibly from the Old Slav word '*sliva*', a plum (from which the Russian drink *slivovitz* originates). As from the 20th century the word has taken on the meaning of 'intensely angry' – possibly in reference to the fact that intense anger can give rise to all or any of the above colours. That the colour word has been hijacked in this way is remarkable particularly seeing that anger is usually associated with the colour red (see, for example, **red mist**).

livid- (L): Ashen, black and blue, blueish.

Living ring: See **Revolving spinning ring**.

Lixivitation: The process of separating a soluble substance from an insoluble by the percolation of water.

Lixivium: (Lye.) A term often used in old dye books, water impregnated with alkaline salts extracted by lixivitation from wood ashes.

Lizard: A rigid snake skin, not usually available for sewing, except sometimes as a trimming. Mainly used for shoes and handbags.

lizard-green: A shade of green resembling the colour of a lizard.

Llama: The hair of the fleece of various animals found in South America. Types of hair include alpaca, vicuna and guanaco.

Llama fibre: See **Llama, Llama hair**.

Llama hair: South American ruminant, member of the camelidae (camel family); its wool is of various colours, having coarse guard hairs with a diameter up to 150 µm and fine under hair with a diameter of 20–35 µm; it has around 100 almost invisible scales per millimetre.

Llanchama: Native Brazilian name for the interior, fibrous bark of the couratari tree; used for clothing, ropes, etc.

LL fabrics: Links-links fabric, purl fabric.

Lm: Llama hair.

Lm: Lumen, SI unit of luminous flux. See **Lux**.

LNG: See **liquefied natural gas**.

Load: Deprecated term, use the preferred term force.

Load: To apply a force.

Load ratio: The ratio of the filling weight of goods in kg to the volume in litres of, e.g., the washing or dry cleaning drum.

Load-at-specified-elongation (LASE): Deprecated term. Use the preferred term, Force-at-specified-elongation (FASE).

Load, breaking: See **Breaking load**.

Load-deformation curve: A graphical representation of the relationship between the change in dimension (in the direction of the applied force) of the specimen resulting from the application of an external load, and the magnitude of that load. The load may be expressed in units of weight (such as pounds or kilograms) and the deformation in either units of length (such as inches or millimeters) in tension or compression tests, or degrees in shear tests. In a tension test, a load-deformation curve becomes a load-elongation curve. Deprecated term. Use the preferred term, Force-deformation curve.

Load-Elongation curve: Deprecated term. Use the preferred Force-elongation curve.

Load-recovery cycle, In elastic fabric testing: A continuous curve or plot of load versus elongation (with movement stopped momentarily at point of reversal) describing the elongation and recovery of an elastic fabric. Also known as the loading and Unloading cycle.

Load, median: See **Median load**.

Load, peak: See **Peak load**.

Loaded: See **Weighted**.

Loading and unloading cycle: See **Tension recovery cycle**.

Loading of Silk: See **Weighting of silk**.

Loaf Cotton: Raw cotton formerly grown in Montserrat, West Indies.

Localized emboss (colour) printing: Principle of a local synthetic resin application (by means of roller or screen printing), which is embossed in the customary

way on the Embossing calendar and then cured. This produces a wash proof design fixed on the synthetic resin sites, similar to *Chintz* printing, and is a coloration process provided that the synthetic-resin precondensate printing paste contains suitable colorants. Printing is followed by pre-dry, emboss, dwell, cure, etc.

Lochrea: Coarse, bleached Irish linen.

Lock: A tuft of wool.

Lock thread canvas: A lattice-effect embroidery canvas, very rigid and kept flat by warp threads locked round the weft threads to avoid movement.

Locknit: See **Locknit fabric**.

Locknit fabric, warp knitted: It is produced by two fully threaded guide bars. Splitting problem is less than that of Tricot fabrics. Locknit fabrics contract widthwise when leaving the knitting zone. It has a curling tendency. Coloured stripes can be obtained by using coloured yarns. The front guide bar generally requires approximately 30% more yarn than the back yarn.

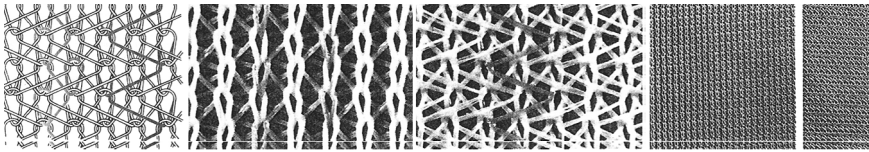

Locknit schematic

Locknit Face

Locknit back

Lockout: Wool with a stringy formation.

Locks: A term used in wool sorting for short oddments of wool which falls from the skirting tables or rare swept up from the boards. In some countries it can include soiled lefts and pieces from near the rumps of a sheep.

Lockstitch (301 Stitch): A stitch that is formed with a needle thread and a bobbin thread that is inter-locked in the center of the seam being sewn. Even though the same amounts of needle and bobbin thread are consumed, the needle thread requires 5 to 7 times more tension than the bobbin thread. Some of the advantages of using a lockstitch in a seam include: the stitch is reversible, produces the tightest of all seams, and uses the least amount of thread.

Locust bean flour: (fine flour), the ground seeds of the fruit of the locust bean, or carob tree, a leguminous plant native to the Mediterranean, giving a very light, almost dusty whitish or light brown flour.

Loden: (1) Dark green after the cloth of the same name.

(2) A thick, fulled, soft fabric, made in Austria and Germany. Predominantly woollen, coloured blended coarse material made from spun virgin wool and fleece (heavily milled and carded, not cropped), also with admixtures of camelhair, alpaca or mohair for higher quality.

(3) Woven woollen goods in an unfinished state (unsized). Heavily milled to make it dense and durable. Used for suits, costumes and overcoats.

London purple: A shade of purple.

Loden cloth: This is a heavy cloth woven from the fleeces of a mountain sheep. It is sift and thick and characteristically green in colour. The fabric is also waterproof, because the rough wool used is oily and coarse and prevents water penetration. Used for coats, capes, duffle coats especially in mountain countries.

Loft: The properties of firmness, resilience, and bulk of a fibre batting, yarn, fabric, or other textile material.

Lofty: A term applied to an assemblage of fibres to denote a relatively high degree of openness and resilience or large volume of a given mass.

Lofty Wool: Wool that is open, springy, and bulky in comparison to its weight. This type of wool is desirable.

Logan: A Highland tartan, made as follows: Dark green stripe; a group, somewhat narrower, composed of red, black, yellow, black, red stripes of even width; dark green stripe; black stripe, wider than green; dark blue field (over four times wider than black stripe), traversed by fine red stripes, spaced from each other the distance of their width; black stripe.

Logwood: A very deep and permanent black dye obtained from the chipped wood of haematoxylon Campechianum, a tree in Central America and surrounding islands. It is used for dyeing silk, which is mordanted and loaded previously by various salts.

Lohi: Men's shawls in India.

LOI: The original term Limited Oxygen Index has in the meantime been shortened to Oxygen Index, i.e. to OI, and may be described as limiting oxygen level.

London shrinking process: The purposeful restoration of the temporary stretching or tension arising in wool or wool-mix fabrics as a result of the production process by applying the principle of Shrinkage. The fabric is laid in a tension-free state in damp decatizing wrappers for approximately 12 hours with subsequent slow and tension-free drying. In the process a cloth shrinks by approximately 5–10%.

London-shrunk: Shrinking machine for wool and wool-mix fabrics. The fabric travels tension-free from the feed roller in a loose loop to the steam cylinder and then over a sloping, polished heating plate where weft and warp are allowed to relax entirely. The speed of the fabric and the steam intensity may be regulated to achieve any desired shrinkage effect suitable to any fabric.

Londres: Very wide, fulled woollen dress goods of English origin. See also **Londrin**.

Londrin: Light, fulled French and English woollens exported to South America and the Levant.

Long and short stitch: An embroidery stitch. This form of Satin Stitch is so named as all the stitches are of varying lengths. It is often used to fill a shape which is too large or too irregular to be covered by Satin Stitch. It is also used to achieve a shaded effect. In the first row the stitches are alternately long and short and closely follow the outline of the shape. The stitches in the following rows are worked to achieve a smooth appearance.

Long cloth: Plain and closely woven bleached or printed, fine and soft cotton fabric; used for underwear. It has very little sizing and is often gassed.

Long cross stitch: In embroidery a variation of the cross stitch (see) the two stitches crossing each other, forming not a perfect square but an oblong.

Long Draw: This is a woollen-spinning technique.

Long Ell: Twilled English fabric made of hard spun single or two-ply worsted warp and woollen filling.

Long knot, in raw silk: Knots that have loose ends from 3 to 25 mm in length.

Long liquor: Used for a liquor containing a large quantity of fluid, e.g. 1 : 40. Opposite: Short liquor.

Long noil: The best grade of silk noils in England.

Long poll: In England a plush with shaggy pile.

Long slug, in raw silk: A slug which exceeds 10 mm (1/2 in.) in length or which is very much larger in diameter than the yarn.

Long staple: A long fibre. In reference to cotton, long staple indicates a fibre length of not less than 1-1/8 inches. In reference to wool, the term indicates fibre 3 to 4 inches long suitable for combing.

Long staple Fibre: See **Long staple**.

Long Wool: Wool from such breeds as the Lincoln, Leicester, and Cotswold. It is large in diameter and up to 12:15 in. in length.

Longcloth: An old fashioned term referring to the first fabric to be produced in long lengths and rolled. If this term is used now, it simply means a plain weave cotton mainly used for handkerchiefs.

Longotte: Plain woven French cotton cloth, much heavier and stouter than calico.

Longs: Trade term for ready-made clothing cut to fit tall, thin men.

Look: Term used to describe a fashion trend or style, appearance of a garment or fabric. e.g. the used look, safari look, etc.

Loom: A machine for producing fabric by weaving.

- (a) *Automatic Loom:* A loom on which the shuttles or pirns are changed automatically.
- (b) *Circular Loom:* A loom on which the shuttles travel simultaneously on a circular path through a wave shed (q.v.).
- (c) *Shuttle Loom:* A loom that uses a shuttle (q.v.) to insert the weft.
- (d) *Shuttleless Loom:* A loom in which the weft is drawn from a stationary supply and is inserted by means other than a shuttle.

There are three main types of shuttleless looms:

- (i) Gripper-Projectile (gripper-shuttle) loom in which the weft thread is taken through the shed by a projectile fitted with a jaw that grips the end of the weft thread during insertion of the pick.
- (ii) Jet Loom in which the weft thread is taken through the shed by a jet of liquid or air.

Note: Because of the nature of these weft insertion methods, the weft yarn in the fabric is in lengths of one or two picks. Consequently, means are usually provided for forming acceptable edges. (See also **Selvedge**.)

- (iii) Rapier Loom in which the means for carrying the weft thread through the shed is fixed in the end of a rigid rod or of a flexible ribbon, that (in both cases) is positively driven. Rapier looms may have a single rapier to carry the weft across the full width, or two rapiers that operate from opposite sides of the loom.

Loom barré: A repeated unevenness in the fabric, usually running from selvage to selvage, and caused by uneven let-off or take-up or by a loose crank arm.

Loom beam: See **Weavers beam**.

Loom efficiency: Loom efficiency is defined as

$$\text{Loom efficiency} = \frac{\text{Actual Production}}{\text{Calculated Production}} \times 100$$

Loom Figured: Fabrics having patterns woven in the loom as against printed or embroidered patterns.

Loom finished: A term describing fabric that is sold in the condition in which it comes from the loom.

Loom fly: Waste fibres created during weaving, that are woven into the fabric.

Loom, air jet: See **Weaving machine, jet**.

Loom, Chief motions of: In order to interlace warp and weft thread to produce a fabric on any type of loom three operations are necessary- (a) Shedding: separating the warp threads into two layers to a tunnel known as the shed (b) Picking: Passing the weft thread through the shed, (c) Beating up: Pushing the newly inserted length of weft, known as the pick, into the already woven fabric at a point known as the fell. These three operations are often called the chief (or basic primary) motions of the loom (weaving). These operations must occur in a given sequence, but their precise timing in relation to one another is also of extreme importance on a power loom.

Loom, Shuttleless: A weaving device that carries the filling yarn through the shed by the use of air or water jets and grippers.

Loom, water jet: See **Weaving machine, jet**.

Loom-finished: Fabric marketed in the condition in which it comes from the loom, and which is given no further finishing. See **Greige Fabric, Loom-state**.

Loom-state fabrics: (loom-state plain weave, loom-state cloth), woven fabric coming from the weaving machine into the trade. The goods as such are not finished but usually merely brushed on a cleaning machine and if necessary steamed. Such loom-state fabrics may be raw fabric (e.g. untreated cotton, homespun etc. = loom-state cloth; hand woven linens = loom-state plain weave) or dyed fabrics (yarn dyed, printed, bleached) or patterned, etc.

Loom-state: Fabric as it comes from the loom, usually unbleached, containing *size*, and maybe a bit dirty. Loom state is essentially synonymous with *greige* or *grey*. Sometime it may imply that the fabric has not been inspected for flaws.

Looney: An oblong, flattened pad, used in pressing and giving form to the collar, lapels and shoulders of a coat.

Loop: (1) Any loop or swag of material, e.g. a loop of yarn, a loop of fabric (in a long loop drier or similar device). Loop fabrics are similar to Bouclé fabrics, except that while the latter's decorative threads possess only knot like thickenings or small loops, loop fabrics have larger round loops which, in the case of strong patterns, may have a diameter equivalent to that of a pencil. (2) (pole stitch, plush stitch) a basic element of knitted fabric in combination with Stitches appearing on the reverse side as regular long loops of thread (plush stitches) which are connected with plain stitches.

(3) Loose, plain woven fabric with large loops on the surface, made by weaving with loop yarns in the weft. Used for jackets and costumes.

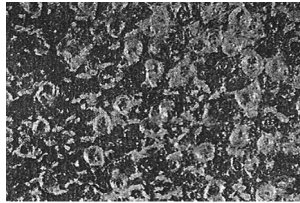

Loop breaking force, in tensile testing: The breaking force of a specimen consisting of two lengths of strands from the same supply looped together in a specified configuration and mounted between the clamps of a tensile testing machine.

Loop breaking load: Deprecated term. Use the preferred term Loop breaking force.

Loop breaking Strength: Strength expressed in terms of loop breaking force (see **Loop breaking force, strength**).

Loop column: See **Tuft**.

Loop drier: Drying machine in which piece goods are moved through the drier in long loops (long loop drier, suspended loop drier) or short loops (Short loop drier) with the reverse side suspended on the rail so that the right side of the goods may dry without contact or tension. Drying systems.

Loop elongation: The maximum extension of a looped yarn at maximum load, expressed as a percentage of the original gauge length.

Loop knot: A snarl or curl produced by a filling yarn due to the excessive length of one or more cocoon filaments.

Loop of yarn, Knitted: A length of yarn bent to shape for incorporation into a knitted structure.

Loop pile, for pile yarn floor covering: Pile in which for each loop a tuft leg of one tuft element is connected to a tuft leg of another tuft element at another

binding site so as to form a loop which projects above the backing fabric between the binding sites of the connected tuft elements.

Loop pile Carpets: A pile floor covering in which the pile is of uncut loops.

Loop row: See **Tuft**.

Loop stitch: A type of hand stitch used for over sewing edges so as not to increase their thickness by having an edge turned in.

Loop stitch: Blanket or loop stitch, used to ornament the edge of blankets, etc., and for finishing the edge of stockinet or web material, is worked from left to right, the edge of the material being held towards the worker. Start with three or four running stitches along the edge so the line of stitching will cover them. Insert the needle the desired width from the edge, draw it towards you down over the thread, being careful not to draw the thread too tightly over the edge of the flannel. Fasten the thread by taking running stitches under the last blanket stitch on the wrong side.

Loop strength, in sewing: The strength when one strand of thread is looped with another strand and then broken. This strength test gives an indication of the brittleness of the fibre being tested. Most polyester sewing threads will have loop strength of approximately 1.5 times the single-end breaking strength.

Loop tension, in elastic material testing: The total tension at any specified extension that is exerted on a specimen in a loop formation.

Loop tenacity: The strength of a compound strand formed when one strand of yarn is looped through another strand, then broken. It is the breaking load in grams divided by twice the measured yarn denier or decitex. Loop tenacity, when compared with standard tenacity measurements, is an indication of the brittleness of a fibre.

Loop wheel machine: A bearded needle circular weft knitting machine in which the knitting takes place on a set of vertically mounted needles, the yarn being manipulated with the aid of a bladed wheel.

Loop yarn: A fancy yarn formed by wrapping an effect thread round a twisted core so that loops protrude from the yarn surface.

Loop, Back: A knitted loop formed on the dial needles on a knitted machine.

Loop, Face: A knitted loop formed on the cylinder needles on a knitted machine.

Loop, Float: A knitted stitch when a needle holds its old loop and does not receive a new yarn. It connects two loops on the same course but not in adjacent wales. Also called a miss-loop.

Loop, held: Held loop is an old loop that the needle has retained. It is not released and knocked-over until the next, or a later, yarn feed. A held loop can only be retained by a needle for a limited number of knitting cycles before it is cast-off. A new loop is then drawn through it, otherwise the tension on the yarn in the held loop becomes excessive even though there is a tendency to rob yarn from adjacent loops in the same course.

Loop, Knit: A stitch in a knitted fabric where the yarn is formed into a loop shape by the knitting elements. Knitting meshes or interlocks these loops to form a fabric.

Loop, needle: is the basic unit of knitted structure. When tension in the fabric is balanced and there is sufficient take-away tension during knitting, it is an upright noose formed in the needle hook. It consists of a *head and two side limbs or legs*. At the base of each leg is a foot (F), which meshes through the head of the loop formed at the previous knitting cycle, usually by that needle. The yarn passes from the foot of one loop into the foot and leg of the next loop formed by it.

Loop, sinker: Sinker loop is the piece of yarn that joins one weft knitted needle loop to the next. On bearded needle weft knitting machines, *loop-forming sinkers* form the sinker loops in succession between the needles – hence the origin of the term sinker loop. On latch needle weft knitting machines, however, the sinker loops are automatically formed as the needles, in succession, draw their new loops.

Loop, Tuck: A knitted stitch when a needle receives a new yarn without losing its old loop.

Looped filling: A woven-in loop caused by the filling sloughing off the quill or by the shuttle rebounding in the box.

Looped pile: A pile surface made of uncut looped yarns.

Looped pile floor covering: A pile floor covering in which the pile is composed of uncut loops only.

Looped Yarn: See **Kink**.

Looper, in tufting machine: A hook shaped flat metal plate, which together with the needle, forms the loops during tufting process.

Looper: A stitch forming part which carries the under thread on some types of sewing machines.

Looping: Generally, a method of uniting knit fabrics by joining two courses of loops on a machine called a looper.

Looping bar: A bar inserted in the bottom of an extrusion meter around which the dried filaments pass as they leave the spinning cabinet.

Loop-knot: See **Kink**.

Looper Thread: Refers to the bottom thread used on a serger or over-lock machine, and the threads that cover the edge of an over-edge seam. Loper threads feed directly off the cone into the sewing machine eliminating bobbin changes.

Loopy edge: See **Loopy selvedge**.

Loopy selvage: A weaving defect at the selvage of excessive thickness or irregular filling loops that extend beyond the outside selvages.

Loopy selvedge: An improperly woven selvage of uneven width or a selvage containing irregular filling loops extending beyond the outside selvages. See also **Beaded selvedge**, **corded selvage**, **loopy edge**, **rough selvedge**.

Loopy yarn, in bulk yarns: See **Bulk yarn (textured)**.

Loose back: Trade term for quilts, having the stitching warps floated on the back. Also name for welts where the wadding fillings are not interwoven with the warp.

Loose course, in knitted fabrics: A row of loops in the widthwise direction that is larger, looser, or longer than the stitches in the main body of the fabric.

Loose edge: See **Slack selvedge**.

Lost end: An end on a section or tricot beam that has been broken at some stage in warping and has not been repaired by a knot.

Loose filling: A fabric defect that is usually seen as short, loose places in the filling caused by too little tension on the yarn in the shuttle or by the shuttle rebounding in the box. Loose filling can often be felt by an examiner when passing a hand over the surface of the fabric.

Loose pick: See **Slack pick**.

Loose stock: A fine, light and loose structure composed of either smooth or tangled individual fibres (naturally washed, cut or torn). For example, loose viscose stock (or viscose flock) refers to piles of viscose fibres, usually cut to 30–150 mm, delivered for the purpose of yarn manufacture. Similarly, loose cotton is also referred to as loose cotton stock.

Loose stock dyeing: Loose fibres, pressed into a cake in a suitable casing, may be dyed with through flow liquor. The case has both a perforated inner wall and a perforated outer wall. Reversal of the direction of rotation of the axial pump allows the flow direction of the liquor to be switched between inside to outside and outside-to-inside.

Lorna forte: Heavy cotton duck, made in Portugal.

Lot: See **Production lot**. A unit of production.

Lot, acceptance sampling: See **Acceptance sampling lot**.

Lot, in acceptance sampling: That part of a consignment or shipment consisting of material from one production lot.

Lot, in acceptance sampling of cotton: The main stock, supply, source of fibres to be sampled.

Lot, in bonded, fused, or laminated fabric: A single run on the bonding or laminating machine in which the processing is carried out without stopping or changing processing conditions, and consisting of either a single dye lot or a single grey goods lot.

Lot, Production: See **Production lot**. That part of one manufacturer's production made from the same nominal raw material under essentially the same conditions and designed to meet the same specification.

Lot, Sample: One or more shipping units taken at random to represent an acceptance sampling lot and used as source of laboratory samples.

Lot sample, in cotton: A relatively large sample taken in the field to represent a consignment, shipment, or lot, for the use in the preparation of the laboratory samples. See **Sample lot**.

Lot sampling unit: A portion of material taken to represent a lot and used as source of laboratory sampling units or test specimens or both.

Lot size: The number of units in a Lot, batch.

Lot system: Dependent upon the organizational combining of all customer orders falling within a period of time so as to make a single large manufacturing order, which may then proceed as a unit through all manufacturing stages up to dispatching (one-way throughput has time advantages, avoids leaving single items behind and improves production control).

Lot tolerance fraction defective (p₂): The process average at which the quality is considered barely tolerable; the process average at which the risk of acceptance is called the consumers risk.

Lot, wool top: The entire quantity, not exceeding 20000 pounds (9100 kg.) of a single combing that comprises a single unit for which a test for neps, vegetable matter, or coloured fibre, or all three combined is desired.

Lotanza: A white linen cloth in Cuba.

Louis Quinze: Lace Imitation tape lace. The patterns are made of braid and connected with bars.

Louisiana: A number of commercial varieties of short staple upland cotton from Louisiana and neighboring States.

Lousine: A plain silk with a glossy texture, and a coarse surface like a very small basket weave. It now often contains synthetic fibres on silk, Used for dresses and coat linings. Hard-wearing.

Lousiness: Flaw in silk or cotton cloth showing speedy spots in the finished goods.

Louver cloth, in coated glass yarn fabrics: A woven netting having an approximately even spaced mesh of fewer than 12 by 12 yarn per 25.4 mm (1 in.).

Lovat: (1) Dull green; from the Scottish town and used in reference to Tweed cloth. Originally 'Lovatt'. Sometimes 'lovat green'.

(2) Although this really describes a colour, it is often used for woollen over coating of good quality in typical lovat colour, which is greeny-grey.

Love: A very sheer, plain silk fabric in England.

Low add-on: Low wet pick-up.

Low-density polyethylene (LDPE): See **Polyethylene**.

Low foaming: The weak foaming characteristic of general purpose washing powders intended for use in a drum washing machine. In resin finishing, it is predominantly compounds based on 4,5-di-hydroxyethene urea which are used, which demonstrably do not split off any formaldehyde in the finishing process, and which in the product itself are set to be low-formaldehyde.

Low/high solids thickeners: Thickening with a small or large amount of Solids content. Low solids thickeners = slow drying, soft elastic film. High solids thickeners = rapid drying, film more or less brittle/hard, contours standing sharply, but danger of splitting off.

Low liquor dyeing: Dyeing process for yarn packages in circulating liquor machines (stacking system) with liquor reduced approx. 50%. Liquor direction exclusively from the inside to the outside.

Low-power stretch: That property of a fabric whereby it exhibits high-fabric stretch and good recovery from low loads.

Low pressure kier: Various designs of kiers are available. Low pressure or open kiers are generally made with a hinged lid, and the scouring liquors are circulated by injector system or by the provision of an external multitubular heater and pump. The steam injector located at the centre of the kier permits the heating of the bath and the liquor is circulated from bottom to top before spraying it on the fibre. Open kiers are mainly used for linen, yarn and cloths made of loosely woven goods and knitted materials etc. which will not stand high pressure boiling in alkaline solutions. This type of kiers are also preferred for coloured woven goods which operates at atmospheric pressure

below 100°C The main disadvantage of this type of machine is the dilution of the bath by condensed steam on account of direct steam heating system.

Low residual shrinkage: Fabric must shrink less than 2% when laundered.

Low rows: A carpet defect characterized by rows of unusually low pile height across the width of the goods.

Low water immersion: A dyeing technique where the liquor ratio is very low, with the intent of producing nonuniform mottled appearance LWI is popular for fabrics for quilting. Typically, a piece of fabric is stuffed fairly snugly into a container, and enough dye solution to barely wet the fabric is poured in. The container and contents are set aside to *batch* for some time. Sometimes multiple colours are used. This is an art dyeing technique that is not used commercially.

Low temperature dyeing: Method of dyeing with direct dyes on cellulose fibres by exhaust method, at the lowest possible temperature (40–60°C).

Low wet pick up: Minimum-liquor application; application of finishing liquors to textiles without excess liquor which would subsequently need to be removed. The principal aim is the capillary saturation of the material, e.g. cotton approx. 35% liquor loading, in general < 40%.

Low Wool: Wool of low 1/4 blood or lower in quality. Same as “**coarse wool**”.

Lowest-Observed-Effect Concentration (LOEC): Lowest constituent concentration in which the measured values are statically different from the control.

Lowland Wool: These breeds are characterized by producing wool that is generally coarser, and only wavy or quite straight, and of longer staple (over 4 inches). These wools are especially suited for the production of combed yarns, which are worked up into worsted fabrics.

Lowry: Name of an improved cylindrical cotton bale formed from a continuous flat coil, fastened with wire ties and enclosed in ‘bagging. Average weight 250 pounds.

LP: Low pressure.

LPG: See **Liquefied petroleum gas**.

LR: Abbrev. for Liquor-to-goods-ratio, in job specifications.

Luana: A fabric characterized by a crosswise rib effect, usually made with a filament yarn warp and a spun yarn filling.

Lubricant in sizing: Lubricants are added to reduce the coefficient of friction and reduce drag as the yarns run over stationary objects. A thorough discussion of these will be found in the section describing oils, fats and waxes.

Lubricant: A material used to reduce friction between surfaces. Lubricants are often applied to yarns that are used for knitted fabrics such as jersey. They help protect the yarn from damage and the machinery from wear. Lubricants can interfere with dye uptake and must be removed by thorough scouring.

Lubricity, in sewing: Refers to the frictional characteristics of thread as it passes through the sewing machine and into the seam. Good lubricity characteristics will minimize thread breakage and enhance sew ability.

Luca: Cloth Medieval fabrics woven of silk and gold or silver in Italy.

Lucet: A layered shaped hand tool of ancient origin, about 70-150 cm. long, made from thin rigid material such as wood, horn ivory etc. It was used making square knotted cords with low stretch and good strength characteristics and was widely used until the advent of the industrial revolution when the manufacture of cords and laces became a machine operation.

Lucetted cord: Square knotted cord produced with the aid of a lucet.

luci- (L): Light.

Ludigol: BASF trade name for sodium m-nitrobenzene sulfonic acid

Luftspitze: Is a lace made on shuttle machine in cotton over a wool foundation or in silk or wool on cotton foundation. After the embroidering is done the foundation is destroyed with chemicals which do not affect the work itself thus leaving a lace like product.

Lukchoo: Chinese fabric, about 16 inches wide, made of silk and cotton. It is often blue and is used for clothing.

Lug: See **Bail**.

Lule: Term applied in the Levant markets to very thick Oriental rugs of heterogeneous origin. These rugs are not folded but rolled.

Lumen: Unit of Luminous flux. See **Lux** and **Phot**.

Lumen, in vegetable fibres: The central canal of the fibre.

Luminance factor: Colour measuring spectrophotometers measure the amount of light reflected from an object in relation to the amount of incident light for all wavelengths of interest. It suffices for colorimetric purposes to measure 16 values with an interval of 20 nm in the visible region of the spectrum, from 400-700 nm. These measured values are termed the total reflectance or luminance factor. They can be expressed as a percentage between 0 and 100% or as a ratio between 0 and 1.

Luminescence: Emission of light not caused by incandescence but rather by physiological processes, chemical action, friction or electrical action. (See both **Fluorescence** and **Phosphorescence**.)

Luminescent: Most dyes and pigments owe their colour to the selective absorption of incident light. In some compounds, colour can also be observed as a result of the emission of visible light of specific wavelengths. These compounds are referred to as luminescent. The most commonly encountered luminescent effects are fluorescence and phosphorescence.

Lumineux: A lightweight French silk fabric, made in variegated effect and 'finished with a lustre; used for millinery trimmings.

Luminosity function (y) (CIE): A plot of the relative magnitude of the visual response as a function of wavelength from about 380 to 780nm, adopted by CIE in 1924.

Luminous dyes: Fluorescent dyes.

Luminous flux: The derived SI unit is the lumen (unit symbol: lm).

Lump: See **Slub, slug**.

Lump: In the English trade cloths woven 130 yards long and 90 inches wide to toe split and cut into half lengths; also any fabric which is woven double its length it is sold in the market.

Lumps: Plain woven, bleached cotton cloth made in England 32 inches wide, with 64 ends and 64 picks in a square inch; used for calicoes.

Lunenburg Flax: A fine variety of German flax.

Luneville Lace: French narrow bobbin lace made of hemp thread with double ground, now obsolete. At the present bobbin-made flower sprigs are sewn to machine-made net.

Lupis: Native name for the fine, white and glossy fibrous layer of the *Musa textilis*; used for delicate fabrics in the Philippine Islands.

Lurex: It is a metallic yarn produced in various colours by coating thin sheets of aluminium on both sides, using thermoplastic resin. The yarn is slippery and breaks easily but will not tarnish. It can be incorporated into a variety of woven and knitted fabric; It is also used for embroidering fabrics and also made into sewing threads.

Lusca: Silk fabric of unknown construction of the Middle Ages.

Lustra fabrics: (from "lustre"). For these goods, highly lustrous wools or hair are used; besides coarse wools, these include mohair and alpaca. In some cases the warp is of viscose and the weft of more lustrous material.

Lustre, Button: The degree of brilliance exhibited in pearlized or pearl buttons.

Lustre: That property of a textile material by virtue of which the latter exhibits differences in the intensity of light reflected from within a given

area of material when reflected from within a given area of the material when the angles of illumination or viewing are changed. The term is frequently associated with the adjectives bright or dull to distinguish between varieties of manufactured fibres.

Lustreine: A fine, wide, wool flannel, slightly napped, similar to broadcloth.

Lustreing: The finishing of yarn or fabric by means of heat, pressure, steam, friction, calendaring, etc., to produce lustre.

Lustora: See **Velour**.

Lustre in textile finishing: By chemical addition or by mechanical means the surface reflection or shining can be increased in textiles. Usually mechanical finishing like calendaring supported by heating, friction, shearing, singeing etc. will increase the shining if fabric appreciably.

Lustre lining: In England a lining fabric, made with cotton warp and a mohair or lustrous worsted filling. It is woven in 4 and 1 weft twill.

Lustre orleans: English fabric of the 19th century, made with cotton warp and bright Yorkshire or Lincolnshire wool filling.

Lustre wool: English long wool, having a strong long and glossy staple; used for dress goods. Lincoln and Leicester are included, also the wools grown in Indiana and Kentucky.

Lustre yarn: Glossy hard spun woollen yarn made of long, soft and lustrous wool.

Lustrene: Lightweight, twilled and mercerized cotton lining.

Lute-, luteo- (L): Yellow, yellowish-brown, yellowish-orange

Luteo-virescent: Greenish yellow.

Luteolous: An orangey-yellow.

Lutestring: (1) narrow black silk ribbon, used for eyeglasses; (2) fine, warp ribbed silk dress goods of high finish.

Lux: Unit of Illumination.

Luxor: A soft, ribbed silk satin; used as dress fabric; also obsolete French woollen dress goods.

Lyons thread: Gold filled thread with copper core; used for braids, trimmings, etc.

LWI: Low water immersion.

Lycra: A two way stretch fibre, Lycra is the Trade mark for a spandex fibre made by E.I. du Pont de Nemours & Co. It has remarkable elasticity and instant

recovery. It is very strong and withstands repeated wash and wear, It has a high resistance to abrasion but its low absorbency enables articles to dry quickly. Fabrics have a neat, flat appearance. The fibre is resistant to perspiration and is not affected by seawater, hence can be very suitable for sportswear and swimwear. It is mixed with other fibres, only a small percentage is sufficient to give the necessary stretch, recovery and holding power. Used for foundation garments, exercise wear, swimwear, sportswear etc.

Lye: Sodium hydroxide solution of high strength (rarely, potassium hydroxide).

Lynx: Silky, soft long fur of this wild cat; colours vary from fawn to grey.

Lyocell: A regenerated cellulose fibre made from wood pulp Lyocell is produced with a process that is environmentally friendly in that the chemicals used are nearly completely recoverable and reusable in the process.

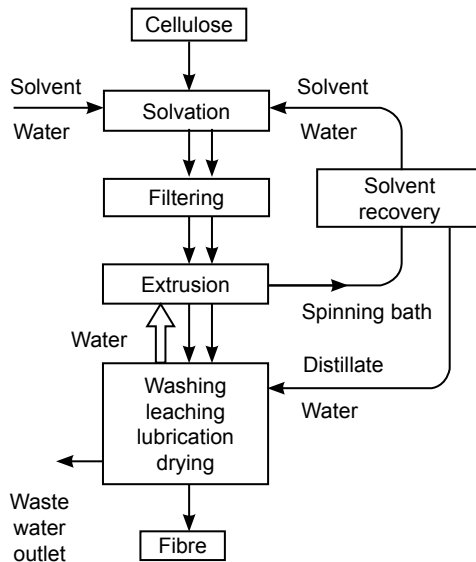

Lyocell manufacturing Process

It is stronger, both wet and dry, than other regenerated cellulose fibres such as viscose rayon, and is also stronger than cotton. In general, lyocell can be dyed much like any other cellulosic fibre. Tencel is one brand-name lyocell fibre.

Characteristics: Lyocell fibre is stronger than other cellulosic fibres. It is inherently absorbent, having a water imbibition of 65%-75%. Lyocell retains 85% of its dry tenacity when wet, making it stronger when wet than cotton. The fibre has a density of 1.15 g/cm³.

End uses: Lyocell fibre is suitable for blending with cotton or other manufactured fibres.

Because of its molecular structure, lyocell has the tendency to develop surface fibrils that can be beneficial in the manufacture of hydroentabled and other nonwovens, and in specialty papers. For apparel uses, the fibre's unique fibrillation characteristic has enabled the development of fabrics with a soft luxurious hand. The degree of fibrillation is controlled by cellulose enzyme treatment.

Lyogel: Fluid-rich Gel of the jelly type. Opposite: Xerogel.

Lyons velvet: A fine quality thick velvet with a stiff, erect, high pile. The backing may be visible through the pile but it is good quality fabric. The backing is made from silk or sometimes linen, viscose or cotton. The pile is silk.

Lyophilic: Prevailing tendency, in a substance which is distributed in a liquid medium, towards endophilia. Solvent-affinity, solvent-attracting characteristic (similar to *Hydrophilic* property). One also speaks of "lyophilic groups" in connection with textile auxiliaries. Opposite: Lyophobic.

Lyophilic groups: Molecular group, which behaves in an Endophilic manner in relation to a liquid phase.

Lyophobic: Solvent-fleeing, anti-solvent, solvent-repelling characteristic (similar to Hydrophobic). Opposite: Lyophilic. When the solvent is water, the word *hydrophobic* is used. The terms are applied to: (a) Ions or groups on a molecule. In aqueous or other polar solvents, the lyophobic group is nonpolar. For example, the hydrocarbon group on a soap molecule is the lyophobic (hydrophobic) part. (b) The disperse phase in colloids. In lyophobic colloids the dispersed particles are not solvated and the colloid is easily solvated. Gold and sulfur sols are examples. *Compare* lyophilic.

Lyophobic groups: Molecular group which behaves in an Exophilic manner in relation to a liquid phase.

Lyotropic: (Gk.) Phenomenon in which the solubility of a substance which is hard to dissolve in a solvent is increased by the addition of a third substance. This third substance is termed a "lyotropic agent".

Lyotropic Polymer: Polymers that decompose before melting but that form liquid crystals in solution under appropriate condition. They can be extruded from high concentration dopes to give fibres of high modulus and orientation for use in advanced composites, tire cord, ballistic protective devices, etc.

M

MA: (1) Modacrylic fibres, (2) Low wet pick-up.

Ma: Manila fibre.

Ma: Symbol for Myria (ten thousand times).

Mackerel blue: A silvery greenish blue.

mxn lapping fabrics: The most popular mxn lapping fabrics are 1×1, 2×1 and 3×1 lapping fabrics. An increase in the underlaying distance (m) leads to an increase in fabric weight, fabric cover factor, smooth appearance at the technical back of the fabric, extensibility in the wale direction and stability in course direction and leads to a decrease in extensibility in the course direction. The most popular fabric designs (one or two fully threaded) which are also described below are produced by this type of lapping.

MA process: Low wet pick-up process as an impregnation process with only low pick-up of finishing liquor, thereby shorter drying times.

MAC: Modacrylic fibres.

MAC: Maximum Admissible Concentration.

MacAdam unit: Colour difference formulae.

Macalister: A Highland tartan, the composition of which is as follows: The ground is red, traversed by very narrow pale blue and white lines, dark blue stripes and green stripes of two different Widths. These lines and stripes are arranged in groups, in every instance a very narrow stripe of the red ground being visible between the parts of each group. These groups follow in order: *Pale blue line, wide green stripe, pale blue line; stripe of red ground, wide green stripe; white line, wide dark blue stripe, white line, two narrow green stripes, white line, narrow dark blue stripe, white line; strip of the red ground, the width of the wider green stripe; repeat groups described above between the two *, In reversed order; wide strip of the red ground; pale blue line, wide green stripe, pale blue line; strip of the red ground, wide green stripe; white line, narrow green stripe, pale blue line, white line, pale blue line, narrow green stripe; strip of the red ground, the width of the wider green stripe; narrow green stripe, pale blue line, white line, pale blue line, narrow green stripe, white line; strip of red, the width of the wider green stripe; pale blue line, wide green stripe, pale blue line; wide red stripe.

Macalpine: A Highland tartan with a dark green ground, arranged as follows: Wide green strip, split in the middle with a narrow black stripe; a group of stripes (twice as wide as the green strip) composed of two black stripes (about twice the width of the black in the middle of the green) at the edge of the group with two very wide black stripes inside. One of these wide black stripes is split with a white and the other with a yellow narrow stripe in the center, the order of the white and yellow being the same in each repeat.

Macana: A closely and plain-spun fine cotton fabric, made with colored checks.

Macarthur: A Highland tartan, composed of the following on a dark green ground: Yellow stripe with a green bar on each side, six times its width; black stripe, twice as wide as the yellow; green stripe somewhat narrower than this black; black bar, about 6 times as wide as yellow stripe; green stripe, as above; black stripe, twice as wide as the yellow.

Macaulay: A Highland tartan, with a red ground, composed as follows: A very wide red field, split by a black stripe in the middle; dark green stripe, two and-half times as wide as black; red stripe, as wide as black one; dark green bar, the width of the black stripe and half of the red field; this green bar is split in the center by a narrow white line; red stripe, the width of the black one; green stripe, two-and-half times as wide as black one.

Macbean: A Highland tartan, the bright red ground of which is traversed by wide groups of stripes, in which the white, black and green lines are very narrow and of equal width and the dark blue stripes are about half the width of the green and dark red ones. The arrangement of the stripes in a group is: *White line, blue stripe, black line, white line, black line, blue stripe, white line, black line, green stripe, black line, white line, narrow stripe of the ground, dark red stripe (split with green line), narrow stripe of the ground, white line*, green stripe; repeat stripes and lines mentioned between the two *, in reversed order. Red ground, somewhat less than half the width of the entire group.

Macbeth: A Highland tartan, composed as follows: 'Yellow stripe; black stripe, somewhat wider; group of white line, black line, white line, black line, total width same as black stripe; green stripe, twice as wide as black*; red stripe (twice as wide as green), split by two black lines and a white line between, spaced; repeat group described between two *, in reversed order; dark blue stripe, just half the width of the entire complete group of stripes.

Macclesfield silk: A high-textured, hard wearing spun silk. The silk yarn is twisted to give a crepey texture, and it is traditionally striped or small patterned. Used for men's ties and women's classic shirts.

Macdonald: A Highland tartan, one repeat of which is as follows: Very wide green stripe, split by two pairs of red stripes, those on the outside being about twice as wide as the inner ones; black stripe, one-quarter the width of the green; red line; dark blue stripe, the width of the green one and split the same way with two pairs of red stripes.

Macdonald of Clanranald: A Highland tartan one repeat of which is: A wide field of dark green, split in the middle by a white stripe and at each side a narrow red line and a red stripe (wider than the white one) the lines and stripes spaced; black stripe, same in width as the distance between the outer red stripe and the edge of the green field; narrow red line; dark blue field (about four-fifths the width of the green one), split by a pair of red stripes (as wide as in the green field) the space between these stripes and the edge of the blue field being equal to the width of the black stripe.

Macdonald of Slate: A Highland tartan with a bright red field. Wide, dark green stripes are placed almost four times their own width from each other; one-third the width of these stripes, and on 'both of their sides are very narrow green stripes.

Macdonald of Staffa: A Highland tartan with a bright red field, on which the stripes are arranged as follows: 'black line; red stripe with a narrow green stripe near to each edge; dark blue stripe, half the width of the red; red stripe, as wide as the first red one, split in the center by a narrow white stripe*; green stripe, as wide as the red and split with a fine, narrow line of white; red field, three-and-half times as wide as the green stripe, split with six dark green, two black and four dark blue stripes, arranged as follows: Green near to each edge, in the center are two pairs of blues, with a pair of green stripes on each side, the inner stripes having a black stripe next to them; repeat group described above between two *, in reversed order.

Macdonell of Glengarry: A Highland tartan, made as follows: Black stripe; narrow red line; blue field, four times as wide as black stripe, split by two pairs of narrow red stripes, of which the outer ones are about twice as wide as the inner ones; red line; black stripe, as above; dark green field, as wide as the dark blue, split by 2 pairs of red stripes of same width and position as found in the blue field and with an additional white line between the two pairs.

Macdougall: A Highland tartan composed of the following: 'Fine green line, near to much wider, dark green, red and dark green stripes of even width; gray stripes, narrower than the former, split by a fine red line in the middle; dark blue stripe, wider than green; red stripe (as wide as the first red) split by a fine green line; green field, three times as wide as red stripe*, gray stripe, split with white and edged with red line on each side (this group being as wide as red

stripe) ; repeat group described between two *, in reversed order; large field of red (the width of the two green fields and the gray stripe between) split by a fine white line in the center, with a narrow gray stripe on each side of the white line, spaced its own width.

Macduff: A Highland tartan composed as follows on a red ground: ‘dark blue, a wider black and a still wider dark green stripe, next to each other*’; red tripe (as wide as the above group), split into three even parts by two narrow black stripes; repeat group mentioned above between two *, in reversed order; red field, made somewhat wider than red stripe.

Mace snag test: A test for evaluation of snagging performance. A fabric sample is mounted on a revolving drum in contact with a miniature mace that tracks randomly across the sample. The spikes of the mace effect the snagging. The test predicts results in actual wear.

Mace snag tester: Testing device for checking the formation of snags in chain hosiery.

Maccio: (1) Coarse bobbin lace made of cotton in Brazil; (2) A variety of Brazilian cotton, having a soft, pliable staple.

Macewan: A Highland tartan, composed of dark green bars on blue and black ground and split by red and yellow lines.

Macfarlane: A Highland tartan, composed as follows: ‘Dark green stripe, bordered on the outer edge with a black and on the inner edge with a white, line; a narrower red stripe, split with a black line; dark blue stripe, bordered on the outer edge with a fine white line on the inner edge with a heavier ‘black stripe; narrow red stripe * ; wide white stripe, split with a dark green stripe; repeat group mentioned between two*, in reversed order; bright red field, being half the width of the entire group of stripes.

Macgillivray: A Highland tartan, composed as follows over a red ground; wide red field, split by a pair of narrow pale blue stripes, each edged with a fine dark blue line on the outside;*pale blue stripe, of same width; very narrow red stripe; dark blue stripe, as wide as pale blue and red stripes combined; very narrow red stripe; dark green stripe, as wide as dark blue and red combined*’; red stripe (as wide as dark green, dark blue and two red stripes combined) split by a narrow dark blue stripe in the middle with a narrow pale blue stripe on each side, these stripes spaced their own width; repeat group described between two *, in reversed order.

Macgregor: A Highland tartan, composed as follows, over a bright red field: Group of three dark green stripes, the middle one being a little wider. This one is split by a white stripe, which in turn is outlined by fine black lines.

The green stripes are spaced one-third their own width from each other in the group, the red space between each group being the width of two green stripes and a red between combined.

Machlipatanam Chintz: Printed dress material manufactured at Machalipatanam, Andhra Pradesh, India. The word chintz is apparently rooted in the Sanskrit chitra (meaning variegated or speckled). The Machlipatanam chintz (old name Masulipatanam) were especially prized, and even in the 19th century they could hold their own in the markets of Burma, the Straits and Persian Gulf against the cheap, machine made cloths from Manchester. Mostly block printed, the Machlipatanam Chintz were famous for two traits: firstly, ‘the freshness and permanency of dyes, the colour being brighter after each washing” and secondly, a strong Persian influence in the design, probably due to the coastal towns trade with Persia.

Machine Cotton: In England cotton thread used in sewing machines.

Machine direction: The long direction within the place of the fabric, i.e., the direction in which the fabric is being produced by the machine.

Machine gauge: The number of needles on a knitting machine per unit of length (generally, the number of needles in one inch length on the needle bed). For a given machine diameter or width, coarser machine gauges tend to knit narrower fabrics and have fewer feeders (fewer cams) due to fewer needles on the machine and a larger knitting cam, respectively.

Machine Lace: A large variety of cotton, wool or silk laces, made on machines.

Machine made Carpets: Machine produced carpets, in the narrower sense, term for machine spun or knotted carpets.

Machine pitch: This is the distance between two neighbouring needles. Cam system (knitting system): one came together with one feeder forms a cam system or knitting system for weft knitting technology.

Machine stitch, in sewing: The resulting arrangement of sewing threads in a repeating unit formed by a sewing machine. It is also called a seam.

Machine stitches, finishing: See **Finishing Machine stitches.**

Machine stitches, Bound: (1) **Self bound seam.** This seam is used to give finishing to the seam margins either on the wrong side or the right side, with help of the extra seam allowance of one piece of the fabric by turning it & placing it over the first seam & giving a edge seam over the fold.

(2) **Bounded Seams:** These seams finish is desirable when one is sewing with fabric that fray easily; also behind the seams when sewing with furs. Main bounded seams are (a) **Open Bound Seam:** Binding is an excellent finish for

fabrics that tend to fray such as tweed and heavy, coarse weaves, as well as for unlined jackets and coats. Stitch a plain seam. Press the seam, and then press it open. With the Binder on the machine and fine bias seam binding, bind each seam edge, using, either straight stitching or an open zig-zag stitch. To prevent seam edges from stretching or fraying in loosely spun fabrics, place a row of stitching 3 cm (1/8 inch) from the seam edge before applying the binding.

(3) **Net Bound Seam**: Delicate fabrics that fray easily, such as chiffon velvet and sheer metallic, may have seam edges bound with nylon net, which prevents fraying without adding bulk. Cut the net into 1 cm strips and insert, attach that bias strip on the seam edges. unfolded, into the Binder with napped or right side up. Stitch, using a medium-width zig-zag stitch. (4) **Plain Bound Seam**: This seam is practical for household items such as cushions, simple loose covers and articles made of plastic. After stitching a plain seam, trim the seam edges to .6 cm (1/4 inch). Press. Insert both edges into the Binder and stitch, keeping the seam edges well into the scroll as you sew.

Machine twist: A hard-twist sewing thread, usually of 3-ply construction spun with S twists and plied with Z twist, especially made for use in sewing machines.

Machine thread, in sewing: Most threads are made of cotton because it is suitable for many different kinds of fabric. Cotton threads are mercerized and available in sizes ranging from No: 20, which is coarse, to No. 80, which is fine. The weight of the fabric determines the size of the thread to be used. The super sheen variety of thread is fine, strong and colorfast and is recommended for most sewing. For terry cotton and other synthetic fabrics, spun, polyester thread may be used. While working with synthetic thread, the upper and lower tension of the sewing machine should be kept slightly loose. When a perfect match of thread is not available, darker shade should be used.

Machine-washable wool: Woollen items, mostly knitted fabric, which are washable in domestic washing machines with a care cycle (ca. 40°C) according to particular Antifelting finish without damaging the appearance of the fabric, handle or wearing characteristics.

Antifelt finishing is generally carried out in the combed top. IWS standards for machine washable items (Superwash).

Machine washable: A label given to garment which can be washed on domestic washing machine, as per care cycle mentioned.

Machine-spun Carpets: Machine spun textile floor coverings like Pile wire; Double plush; Reversible; Axminster carpets.

***Machine zigzagged seam finish**: Used for fabrics that fray. This stitch finish needs a modern machine featuring stitch combinations. Set the stitch regulator

to a short stitch length (about 15 stitches per inch) and a medium width stitch. Zigzag stitch as to close the cut edge as possible. It has the stretch which makes it a good seam finish for knits. Used where under arm and crotch seams needs the edges finished together all-in-one after they are double stitched and trimmed.

Mackinac: Using heavy woollen yarn made from recycled wools and wastes, this fabric is of double cloth construction in a pallid design. It is a strong durable cloth, but of medium price and quality. It is a very common fabric with miners, lumber jackets and hunters. It is also used for camping blankets, heavy outdoor shirtings and cold weather jackets.

Mackinaw: Named for MacKinac Island, Michigan. Made of Wool. Ordinary grade of wool and often has shoddy re-used or remanufactured wool mixed in. Sometimes a cotton warp is used. Twill or double cloth. Weave is concealed. A heavy woollen fabric heavily felted and napped on both sides. Construction is like Melton but the structure is not seen due to felting and napping. They are spun in large checks with coarser woollen yarns when compared to Melton or brightly coloured, or different colours on each side.. Used for blankets, cloaks, lumber jackets for cold climates. Also called ski cloth or snow cloth. In addition to cheaper woollen yarns cotton or waste yarns are often mixed. Also called Mackinac. Used by miners, lumbermen, hunters, trappers, fishermen, and cowboys use much of the fabric for jackets, mackinaws and coats. Also used for blankets, shirts, and some heavy sportswear, windbreakers.

Macinnes: A Highland tartan, composed as follows over a bright red ground; red stripe; group of two black and two red stripes of even width, entire width same as former red stripe; black stripe (over twice as wide as first red stripe), split by a narrow pale blue stripe in the middle; group of two red and two black narrow stripes, as above; red stripe, same as first one mentioned; yellow and red stripe of even width; dark blue stripe, as wide as yellow and red together; red and black stripe of even width, as wide as dark blue; dark green, twice as wide as dark blue, next to black, with another black stripe along its other edge*; red stripe, one- third of which taken by a white stripe; repeat group described above between two*, in reversed order.

Macintosh: A Highland tartan with a bright red ground; the design is composed as follows: *dark blue stripe; a narrower red stripe; green stripe, as wide as the first two combined; *red stripe, as wide as the green, split by a narrow blue line in the middle; repeat, in reversed order, group described between two *; wide red bar.

Mackintosh: Obsolete, waterproof coating. It was rubber on cotton with an adhesive to joint the two. The rubber perished in a short time and the fabric

could not 'breath' and so caused condensation. Now the name Mackintosh has become generic to a waterproof coat, whatever the fabric.

Macintyre: Highland tartan, composed as follows on a dark green field: Two wide, dark blue stripes, each split by a red stripe, spaced from each other by the width of the red stripes; dark green bar (as wide as two dark blue stripes and space between together), split by a white stripe in the middle.

Mac Iver: Commercial variety of late maturing upland cotton from South Carolina, the staple measuring 22-2'5 millimeters; the yield is 30-32 per cent.

Mackay: A Highland tartan, composed as follows over a dark green ground: A black, two dark blue and another black stripe of equal width, spaced from each other by one-eighth of their own width; green bar (as wide as a black and blue stripe, with a spacing between combined), split by a black stripe, as wide as green spacing.

Mackenzie: A Highland tartan, composed as follows: Dark green bar, split by a narrow white stripe, which is edged on each side by a black line; black stripe and dark blue stripe, each as wide as green on each side of above narrow group; narrow red stripe, edged with black lines, as wide as white and black group; repeat, in reversed order, stripes described between two ; black stripe, as above; dark blue bar, twice as wide as black stripe, split near each edge by a pair of fine black lines; black stripe, as above.

Mackinaw: A heavy double fabric, made in striking colored patterns of all wool or mixed with shoddy; it is more or less felted and finished with a good nap; used for coats.

Mackinaw Blanket: Very heavy, all-wool blanket, dyed red, blue or spun in stripes; used for camping and outdoor life, as it is almost waterproof.

Mackinaw Flannel: Very heavy, napped, woollen fabric, usually red or blue; used for shirts, etc.

Mackinlay: A Highland tartan, composed as follows: dark green stripe, one third of which is occupied, in the center, by a red stripe, edged with black lines; wide black stripe, half of entire green stripe; dark blue stripe, three times as wide as black, split near each edge by a pair of narrow black stripes; wide black stripe, as above; repeat group described between two ; wide black stripe, as above; dark blue stripe (twice as wide as black stripe) split by a pair of narrow black stripes in the middle; wide black stripe.

Mackinnon: Highland tartan, composed as follows, over a red ground; Green stripe; red stripe, split with white and edged with black; next to black dark green stripe, twice as 'wide; red stripe, twice as wide as green; narrow green and wider dark blue, next to each other, as wide together as green stripe;

narrow red stripe; wide green stripe, somewhat wider than wide red stripe; red stripe, less than half the width of former green stripe; group of dark blue and green (of equal width and placed next to each other) as wide as red stripe just mentioned; “group of red, black and red stripes of equal width, each as wide as half of the former group; repeat, in reversed order, groups mentioned between two.

Mackintosh: Cloth treated with rubber; sometimes two layers of cloth are united with pressure, having a rubber layer between; used for raincoats.

Maclachlan: A Highland tartan, composed as follows: Wide rose bar, split by one pair of narrow black stripes placed near one edge and spaced evenly from each other and the edge; wide black stripe, as wide as former two narrow black stripes and two rose spaces; dark blue bar, about three times as wide as wide black stripe, and split by a green stripe in the center; wide black stripe*: rose bar as wide as blue bar, and split in the center by a pair of narrow black stripes; repeat groups mentioned between two, in reversed order.

Maclaine of Loehbuie: A Highland tartan, composed as follows: Two dark green stripes, with a pale green between, of equal width, and next to each other, the pale green being split by a yellow line in the center; red bar of the same width as combined group.

Maclaren: A Highland tartan, composed as follows: Dark green bar, split in the center by a narrow, yellow stripe, which is edged by black lines, each green stripe being further split by a narrow, red stripe, placed nearer to the outer edge; black stripe about one-eighth of green field; dark blue bar. slightly narrower than green field.

Macllean of Duart: A Highland tartan composed as follows: Wide, dark green stripe; a group (narrower than green stripe), containing a fine line of black, white, black, yellow, a stripe of black and line of pale blue *; dark blue stripe, as wide as above group; repeat, in reversed order, groups mentioned between two *; red field (as wide as entire complete group above) split in the center by narrow lines in pale blue with black between, placed very close to each other.

Maclennan: A Highland tartan; see description under **Logan**.

Macleod: A Highland dress tartan, composed as follows: Three wide black stripes, divided by very narrow yellow lines; wide yellow bar (somewhat wider than former group), split in the center by a narrow red stripe.

Macmillan: A Highland tartan, composed as follows: Wide yellow bar, split by a narrow crimson line in the center, each half being split again in the center by a wider crimson line. A crimson bar, as wide as the yellow one, split near to the edge by a yellow stripe and in the middle by a pair of fine lines.

Macnab: A Highland tartan, composed as follows: Wide red stripe, split in the center by a narrow crimson stripe; crimson stripe (more than half the width of the red stripe) split by two narrow dark stripes, and spaced their own width and placed near the edge away from the rep stripe*; dark green stripe, measuring half the width of first red one; repeat group mentioned between two, in reversed order.

Macnaughton: A Highland tartan, composed as follows: Wide green stripe; black stripe, half of the green; dark blue stripe, half of the green; red stripe, about two and a half times as wide as the green, split by a dark 'blue stripe (half of the green), this being split again by a fine black line; repeat group, in reversed order, mentioned between the two. In the filling the wide red stripe is split by a solid dark blue stripe, half the width of the green.

MacNeil: A Highland tartan, composed as follows: Black stripe; dark blue stripe (more than twice as wide as black), split by a white stripe, which leaves on each side a blue stripe equal in width to the black; black stripe; dark green stripe, as wide as the blue, split in the center by a narrow stripe, outlined by blue, the green on each side is as wide as the black stripe.

Macnicol: A Highland tartan, composed of black and green stripes and black, green and pale blue lines on a red ground.

Maco: Variety of raw cotton from Egypt, reddish/brownish/yellow, first-rate Egyptian cotton; very fine, longitudinally stapled fibres, uniform spun yarns.

Maco cotton: See **Maco**.

Maco cotton test: These are tests to identify Maco Cotton. Common tests are: (a) Staple length. (b) Boil sample with thinned nitric acid: real maco turns yellow; reddish tone disappears. If the colour shade becomes considerably, deeper however, simple steaming was carried out. (c) Effect of concentrated sulphuric acid: chromatic shades of colour are produced with direct dyeing. (d) Boiling with tin salt and hydrochloric acid: decolorizing with sulphur dyeing. If you hold lead acetate paper over the reagent glass opening when boiling, dark brown/black dyeing appears with sulphur dyeing. (e) With potassium hexacyanoferrat (II) and hydrochloric acid: blue coloration with iron buff dyeing.

Macphee: A Highland tartan, composed as follows over a bright red ground: Wide dark green bars with narrow green line along each side (spaced its own width); these groups of three are placed from each other farther than their width, each alternate red space being split by a fine white or yellow line.

Macpherson: Several Highland tartans. The dress tartan is composed as follows: Wide red stripe, divided into three even parts by two narrow dark

blue lines; green stripe, as wide as one section of the former red and a blue line combined; very fine yellow line; black stripe, as wide as a single section of the red; dark blue about twice as wide as the black, split in the center by a pair of fine black lines; red stripe, as wide as dark blue, split in the center by two fine white and 'between these two fine black lines, all placed very close to each other; repeat, in reversed order, group mentioned between two.

Macquarrie: A Highland tartan with a red ground, composed as follows: Wide stripe of dark green; red field, a little over three times the width of green stripe, split near to each edge by a pair of closely spaced very narrow green stripes.

Macqueen: A Highland tartan, composed as follows: Wide red bar, divided into four even parts by three narrow black stripes; a black bar, considerably wider than the red, split in the center by a narrow yellow stripe.

Macrae: A Highland tartan, composed as follows: Dark blue stripe, split in the center by red line; a narrow white line, separated from the blue stripe by a narrow red line, is along each edge; red stripe, wider than the blue, split in the center by a pair of closely spaced green lines; green stripe, wider than the red, divided into three even parts by two narrow red lines; repeat, in reversed order, groups mentioned between two; red field, as wide as the two wide red and green stripes combined, divided into five equal parts by four groups of closely spaced groups of three dark blue lines each, the middle line in each group being somewhat wider than the lines on the outside and the blue groups measuring the same width as the red, between the groups.

Macrame': A type of knotted construction. Used sometimes in carpets, threads are elaborately knotted by hand from the warp threads which stick out of carpets. Can be used as a needlework technique with typical varied knottings, e.g. for flower garlands wall decoration etc.

Macrame' lace: A revived craft with modern application, this was originally a Spanish knotted lace in geometric patterns, often with fringed ends. Any thread, yarn, wool or string may be used to produce fine or coarse designs. The threads are anchored to a board which may have a paper pattern on it. Motifs may be made or complete items such as mats, bags etc.

Macrofibrils: Macro form of fibres. Normally any basic polymer structure by bonding (for example hydrogen bonding in cellulose) forms microfibrils and these micro fibrils are organised to form macro fibrils. These macro fibrils are organized into fibres. In case of wool, designation for cell units of the fibrillar type in Wool structure, e.g. firstly in the sense of spindle cells and secondly where there is no direct connection with the actual fibrils (bundles). Integrated process of sulphur-rich keratin proteins, which show a variable affinity for

heavy metals after reduction. Macro fibrils in inter macrofibrillar material are a biological unit in keratin fibrils.

Macrolattice A repeating structure in very small micro fibrils of alternating crystalline and amorphous regions. Yarn properties are thought to be governed by morphology at the macrolattice scale.

Macromolecules: (a) Expression for polymers (coined by Staudinger), high molecular so-called “gigantic molecules” made of at least several hundred atoms with molecular weight > 10 000. Structure made of Monomers, either thickly knotted or cross-linked (starch, aminoplasts, phenolic plastics) or more or less longitudinally stretched Chain molecules (Polymers) as in cellulose, polypeptides, etc. Classification into a) natural macromolecules (e.g. starch; cellulose; pectins; caoutchouc; proteins; enzymes); (b) converted (regenerated) natural macromolecules (e.g. viscose; vulcanized caoutchouc; leather) and (c) synthetic macromolecules (e.g. polymerization-, polycondensation-, polyaddition products). Special natural macromolecules are mostly mixtures of macromolecules similar in construction, but different in size.

Macroscopic: Visible with naked (so-called unarmed) eye; e.g. small individual fibres of a yarn, whose surface structure is however Microscopic.

Madagascar lace: Has the threads twisted into loops and scallops; made by the natives of Madagascar.

Madam: Soft finished white shirting In Turkey.

Madapolan: (1) A bleached or dyed, occasionally printed, plain cotton fabric with a soft finish in a wide range of qualities used for ladies wear. (2) Plain spun, sized cotton fabric, heavier than chiffon; used for embroidery foundation in German, Swiss and Austrian factories, and also for shirts; (3) Various fine bleached cotton muslins in Serve.

Madai: Strong and silky seed hair, grown on the giant *Asclepias* in India.

Madder: A plant, called *Rubia tinctorium*, grown in Asia, the root of which yields a rich and fast scarlet dye. Effective component: alizarin (dioxyanthrachinon) Mordant dye for wool and cotton. Total fastness even surpasses indigo. Was already mentioned in the Bible (Egypt, Persia and India). Had its heyday during the 17th century.

Madeira embroidery: Is worked upon fine cambric in eyelet patterns, similar to the modern English embroidery.

Madeira lace: The early specimens are coarse torchon laces; afterward bobbin laces made in imitation of malines and other laces.

Made-to-measure polymers: It is possible to construct polymer molecules chemically using their chemical structure so that they are either extremely

flexible and form irregular balls in melting or else are even in liquid crystal form even before solidifying into stiff rods in a strictly parallel packing. The material spectrum of made-to-measure polymers ranges from polyethylene with flexible tangled molecules to polymers with noticeably restricted flexibility (polyester on polyethylene terephthalate base) and also the stiff-chained liquid crystal polyesters (LCP) or even to the extremely rigid structures of carbon polymers, which include, for example, carbon fibres, carbon glass and carbon-fibre-reinforced composites (CFC).

Madras: Originally made from a fine cotton warp and silk weft. Today madras is made from long staple cotton yarns, preferably combed yarns. Sometimes fine spun synthetics are used in weft to resemble the original Madras. 70 x 70 with 40s warp and weft can be considered as a typical construction of an

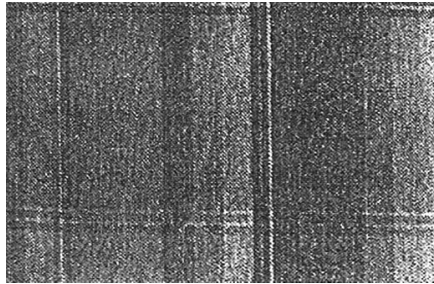

average grade. A fine grade madras made with 2/80s 70 × 70 texture in plain weave with fine stripes, cords or small checks, but are usually accentuated by weaving the decoration ends on a satin basis. Bright shades are favoured in Madras apparel fabrics. Madras curtains are spun with a plain leno weave, with large floral designs inserted using jacquards. Uses: Men's and women's sportswear of all kinds, dresses, separates, shirts.

Madras Cotton: A soft cotton, rather like gingham, but including more colours. It is often rough and unfinished and colours bleed when washed. It is also inclined to fade

Madras gauze: A very light fabric, the foundation of which is in gauze weave, the designs being formed by an extra heavy weft; the floats are cut away; used for dresses, etc.

Madras gingham: See **Gingham**.

Madras Lace: Black and white silk and cotton bobbin lace, made in Madras in Maltese patterns.

Madras muslin: Made in Far East, this has a fine and open gauze foundation of cotton, with figured textures and design in thick, soft spun, weft threads.

IN better quality fabric, two or more different colours are introduced. An inexpensive fabric used for sarees, blouses, nightwear.

Madras shirting: A fine, lightweight, and often colourful, cotton material of better quality than Madras Cotton. The fabric is plain with spun stripes in satin weave, which may be another fibre such as viscose, or in an expensive fabric, like silk. Used for men's shirts, women's dresses.

Magazine screen printing machine: Magazine screen printing machines were the first step towards full mechanization of screen printing. The development started from the fact that a machine with the smallest space required was requested for reasons of space. The printing table is only large enough to enable printing of a report and is equipped with moveable back grey printing in the form of an endless ribbon. The printing screens in question are accommodated in magazines of different design. A distinction is made between staple magazines and magazine screens. So-called "Carousel suspension" and "Serial magazines" are recognized in magazine screen design.

Magenta: A bluish-red colour Magenta is the "official" *subtractive* reddish colour. (Comments paralleling those for *cyan* apply.) In the *MX* reactive dye family, Red MX-8B and Red MX-5B are good magentas. Many dye sellers in the textile arts market call this "fuchsia".

Magnesium chloride: (chlorinated magnesium), $MgCl_2 \cdot 6H_2O$; molecular weight 203. Melted and in crystals, very hygroscopic, water-soluble. Application: finishing additions (hygroscopes, binders and hardening agents), etc.

Magnesium hardness: (MgH), unit per degree of magnesium oxide (MgO) 7.15 mg/l water. See **Water hardness salts**.

Magnesium silicate: Agent for stabilising and controlling the oxygen output in bleaching agents; slightly alkaline to neutral, resistant to temperature and alkalis.

Magnesium sulphate: (epsom salt, sulphuric acid magnesium), $MgSO_4 \cdot 7H_2O$; molecular weight 246; density 1.68. Colourless crystals, often impure, resistant to damp air, weathered in dry air, water-soluble. Application: finishing addition (hardening and sealing agent in particular for cotton goods) in flame-retardant impregnation.

Magnetic rating: An empirical value that reflects the effect of magnetic particles such as magnetic iron compounds, in asbestos material as measured by a magnetic analyzer.

Mahogany or Anacardium gum: Vegetable gums from Brazil, Martinique and Guadeloupe, which are very similar to gum arabic. Reddish colour. Besides

mainly arabinose also contain bassorin and dextrin. They are not completely water-soluble.

Mahout: (1) In the Levant trade a fine and light, fulled cloth, made in Europe, of fine Spanish wool; (2) Also a coarse woollen fabric, used in Egypt and Asia Minor for garments.

Maibafi: Very thin Japanese reeled silk.

Maiden: The name for the posts that support the flyer on a spinning wheel. Maiden and the base that supports them is called the mother-of-all.

Maifoss process: Dyeing to achieve “2 shades” on the same wool fibre or on different wool fibres in one dye bath. Particularly selected dyestuffs are used for this; besides these you can use dyeing auxiliaries, which also increase the colour contrast.

Mail cloth: A highly finished silk cloth spun like honeycomb; used for embroidery foundation.

Mailles de bas: Plain French serge dress goods, having eight leaves and four picks in a repeat.

Maize starch: Starch extracted from Maize. Crystals, pieces, powder. White/yellowish/red, a little more gloss than wheat starch. Handle as wheat starch (not so crunchy). Seldom distorted. Water content 12–14%. Heated bloating: swelling at 50°C, start at 55°C, end of glueing at 62.5°C. Paste: Greater adhesive and stiffening strength than wheat and potato starch, less than rice starch; acidic production thinner; alkaline thicker. Reaction against chemicals such as potato starch. Chemical finishing handle: very hard, but very pithy. Application: Sizing of yarn, finishing etc.

Majagua: Very long bast fibre, yielded by the *Hibiscus tiliaceus* of Central America. Does not deteriorate in water.

Majestic 88 needles: These hand sewing needles are English needles with a special coating allowing easy stitching through cotton batting or difficult - to - needle fabrics. Sizes 9, 10 and 12.

Major defect: A defect other than critical, that judgment and experience indicate is likely to materially reduce the usability of a product for its intended purpose.

Major imperfection, in fabric grading: A deviation in a roll of fabric that judgment and experience indicate is likely to have an adverse effect upon subsequent processing of the fabric.

Makaloa: Fine mats, made with colored geometric patterns of the young leaves of a sedge, *Cyperus laevigatus*, in Hawaii; used for garments, etc.

Makatlik: Turkish name for Oriental runners; used as divan covers.

Malabar: Indian cotton handkerchiefs printed in brilliant contrasting colors.

Malachra: Long, fine and silky fibre of the *Malachra capitata* in the West Indies; used for ropes.

Malasap: Coarse fibre used for cordage in the Philippines.

Malborough: See **Malbrouk**.

Malbrouk: Obsolete French wool serge, made very smooth, with small designs. It had a hard twist, single warp. The spacing of the warps and that of the picks was about equal.

Malcolm: A Highland tartan, composed as follows: Dark green stripe; group of the same width as green, composed of black, pale blue, black, yellow and 'black lines of equal width; dark green stripe, as above; black stripe, as wide as green; dark blue stripe more than twice as wide as green, split in the center by a pair of closely spaced fine red lines; 'black stripe, as above.

Malefique: A stout, twilled Belgian worsted fabric; used for bags in pressing oil.

Malida: Indian fabric made of goat's hair; the best grades contain large proportion of the hair of the Thibet goat.

Malifil process: Stitched-bonded composites from bonded threads, e.g. from an untwisted thread with polyamide threads "sewn in".

Malimo: A type of fabric constructed and made in East Germany and produced at a great speed using three sets of yarns, filling yarn placed across the warp and a third system which stitches them together. Technically this fabric is neither spun nor knitted. It is very stable and doesn't move or 'give'. It is often ribbed in appearance. It is mainly acrylic but other fibres may be used. Used for curtains tablecloths for indoors and out, bedspreads and chair covers etc.

Maline: Trade name for hexagonal open mesh, plain net of silk or cotton, usually finished with size; comes in black and white; used for trimming dresses and millinery.

Malines: A stout, plain spun worsted of two or three-ply warp and single filling of a different colour.

Malines Lace: Bobbin lace with sprigs or dots outlined with a heavier cordonnet over a hexagonal or round mesh ground. It is made in one piece of white flax thread.

Malino: Very long, strong leaf fibre, yielded by the aloe in Hawaii; used for cordage.

Malipol fabric: Stitch-bonded fabrics as a combined stitch-bonded yarn composite fabric type. Conventional textile fabrics (e.g. viscose staple fibre) with pile loops (1–7 mm) threaded to one side of the fabric using stitch bonding and the back of the fabric covered with stitches. I.e. chain plush fabric with pile threads bonded using stitch formation in contrast to tufted fabrics, where loops sewn in have to be bonded with adhesive on the back. Application for Terry fabric goods, duvets, furnishing fabrics, carpets, rugs, coat fabrics in types of fleece and velour, car upholstery and technical textiles.

Maliwatt fabric: Stitch-bonded fabrics made out of over sewn nonwovens, with/without binding bonding; for interlinings, felts, upholstering fabrics, coating base for artificial leather, technical purposes; also layered agents for clothing fabrics, raised lining fabrics and artificial leather.

Mallory fatigue test: A test to measure the endurance properties of tire cord.

Malmal: Native East African name for bleached cotton muslin. Also generic term for the finest cotton muslins in India, often embroidered in gold. See also **Mull**.

Malo: A very fine netted fabric in Hawaii, made of olona fibre, and used for loin cloth by the natives. Often feathers are sewed to it.

Malt: Aqueous extract from germinated cereal grains (barley); contains amylase and maltase as diastatic, starch degrading (condensing via dextrines to maltose) enzymes (ferments). Malt diastases.

Maltase: A glucosidase as an enzyme of malt (malt diastases), which the starch decomposition (into maltose) already effected by the amylase continues to form glucose.

Malt diastase: Obtained from germinating barley; consist of α - and β -amylases (Diastases). The effective malt diastatic enzyme decomposes starch into maltose. Effectiveness: PHs of 4.5–6.2, 50–65°C and quantities of 3–20 g/l of sodium chloride addition have an active effect. Alkali, copper, tin and lead salts act as enzyme poisons.

Malt enzymes: See **Malt diastase**.

Maltese lace: Similar in appearance to Cluny Lace, it is heavy and often incorporates regular wheel designs and squares. Used mainly in small areas such as corners of handkerchiefs and table linen.

Mamaki: Fibres yielded by the *Pipturus albidus* in Hawaii; used for coarse cords and ropes.

Mammoth: Two commercial varieties of late maturing upland cotton from Georgia, the staple measuring 28-30 millimeters; the yield is over 30 per cent.

Mamoudis: Very soft, fine, yellowish linen, originally from Persia.

Manchester Cottons: (1) Originally woollen fabrics made formerly in England, measuring 22 yards in length, three quarter yard in width, and weighing 30 pounds at least; (2) At the present a great variety of cotton fabrics made at Manchester, England.

Manchester velvet: All-cotton velvet made in England with plain weave back.

Manchu Crepe: Cotton or silk crepe, made with very fine warp stripes of colored silk thread.

Mandarine: French fabric, spun with cotton warp and silk filling.

Mandrel: Thread shaft for transmitting a rotary motion.

Mandrel jack: Machine for fitting printing rollers on mandrels onto the steel shaft.

Mandrell: The core around which the impregnated filaments are placed to form a specified shape in composite manufacture.

Mandrenaque: Cloth from the Philippines made of cotton warp and palm fibre filling.

Mandypyta: Raw cotton from Paraguay, yields a reddish brown staple; used for ponchos.

Mandyu: Native name of three kinds of raw cotton in Paraguay, yielding white staple.

Mangle: A system of two rolls which is used to squeeze the fabric in wet processing. It can be same type or a combination of two type rolls. Ebonite/Rubber (Synthetic or natural) or Rubber/Rubber are very common.

Mangling: The process of squeezing the fabric while passing through two rolls. See **Mangle**.

Manila: Fibre obtained from the leaf stalks of the abaca plant. It is generally used for cordage.

Manila fibre: See **Manila**.

Manila hemp: Very light, tenacious and lustrous fibre, yielded by the *Musa textilis* in the Philippine Islands; used for ropes and for the finest sheer fabrics. The principal classes are current, fair current and brown. The quality grades are marked as: Fair, medium, coarse and coarse brown. The fibre is also called very short (less than 4 feet), short (4 to 5 feet), normal (5 to 8 feet), long (over 8 feet).

Manillese: Embroidered and often knotted drawn work made of agave fibres in the Philippine Islands.

Manirito: A useful fibre, yielded by the bark of a species of the sour-sop in Venezuela.

Man-made fibre: A class name for various genera of filament, tow, or staple produced from fibre forming substances which are chemically synthesized or modified. (a) Made from natural polymers: Regenerated cellulose; Man-made protein fibres; Mineral fibres. (2) Made from synthetic polymers (Synthetic fibres): Polycondensation fibres; Polymerization fibres; Addition polymers.

Man-made protein fibres: (protein man-made fibres, regenerated protein fibres), nozzle-spun manmade fibres made from natural polymers on base of protein solids:

(a) *Vegetable origin:* vegetable protein fibres such as: Zein; Arachin fibre; Glycine.

(b) *Animal origin:* animal protein fibres such as: Casein; Fibroin.

Man-made protein fibres, distinguishing tests: Boiled in 0.1% ninhydrin solution for 1–2 min fibres appear dyed as follows: groundnut protein fibres = greyish brown, zein fibres = grey-blue, milk casein fibres = faint purplish blue, soya fibres = undyed.

Man-made staple fibre: Fibre of spinnable length manufactured directly or by cutting filaments.

Mannose: Belonging to the simplex sugar types. Occurring as a component of similar sugar polysaccharides, e.g. predominantly involved in the structure of Locust bean flour (galactomannan, carob). In its pure state (commodity) white, sweet-tasting crystal powder, easily water soluble.

Manofast: A trade name for thiourea dioxide.

Manometer, pressure gauge: Pressure measuring device for gas, vapour and air pressure (also fluid pressure), which exceeds or falls below normal pressure. There are different types:

(1) Fluid manometer: Simplest type (similar to Barometer) as an open U-tube filled with fluid (mercury, paraffin oil or coloured kerosene), connected on one side or (for differential pressures) on both sides, board mounted, mm pitch, reading off the level stand above and below (rounded distance). Only for low excess pressures (often below 1 bar). (2) Diaphragm pressure gauge: oval housing, airtight clamped diaphragm (corrugated sheet metal), one side with overpressure connection, another side with pushbutton, little gear wheels, pointer and calibrated measuring scale. 3. Tube spring manometer: tube spring

bent in three-quarter circle (Bourdon tube) with oval cross section made of brass or (for maximum pressure) bored steel tube, one side above with excess pressure connection, other side closed with lever-operated transmission, counting segment, gear wheel, pointer and calibrated measuring scale.

Manta: (a) In Central America, term for gray cotton sheetings; (b) In Colombia, various kinds of cheap cotton fabrics or plain spun goods.

Manta Blanca: Bleached cotton sheeting in Mexico.

Mantel Grijn: Cross ribbed Dutch camlet, made with two-ply goats' hair warp and worsted filling, having warp ribs.

Mantelle: A medieval English worsted.

Manteau: Courtly women's outer robes; bodice and usually open skirt from the same material, used in ancient times.

Mantilla: Shawl, usually triangular covering the shoulders and sometimes the head.

Manto: Plain black shawl, worn by Chilean women; usually made of wool or mixed with cotton.

Manufactured fibre: A class name for various genera of filament, tow or staple produced from fibre forming substance which may be (a) polymers synthesized from chemical compound, (b) modified or transformed natural polymers, (c) glass. The term manufactured usually refers to all chemically produced fibres to distinguish them from the truly natural fibres such as cotton, wool, silk, flax, etc.

Manufacturing based, in quality testing: This definition is concerned with engineering and manufacturing practices based on conformance to requirements or specifications. These specifications are set by design and any deviation from them implies a reduction in quality. Excellence is not necessarily in the eye of the beholder but rather in the standards set by the organisation.

Maolao su Chiyong: Scarlet red Chinese silk velvet.

Marabout: (1) A delicate thin silk fabric made from twisted raw silk. Used for blouses, linings and lampshades. (2) White silk thread used for crepe, made of three strands twisted together very hard, and dyed in the gum; (3) A very light silk dress fabric, or ribbon, similar to the crepe in appearance, spun of marabout yarn in plain weave; 3, five or eight leaf, silk satin; used for millinery. It is made with single warp.

Marabout silk: See **Marabout**.

Maracapas: A Philippine fibre; used for ropes.

Maragnan: Formerly the best grade of raw cotton grown in the West Indies; now less known.

Maranham: Raw cotton from Brazil with glossy, yellowish and strong staple, sometimes quite dirty.

Maratarong: Philippino name for a coarse fibre used for cordage.

Marble cloth: See **Marbled cloth**.

Marble silk: A soft lightweight silk fabric with a mottled appearance. This effect may be achieved by the use of multicoloured yarns or by wrap printing. Used for blouses, as a lining fabric, and for lampshades.

Marbled Cloth: A silk and wool dress goods in England, spun with a mottled face in various colors, produced by multi-colored weft.

Marbre: A medieval French worsted, spun to imitate the veins of the marble.

Markal I process: Old scouring process by ICI. The dry cloth first passes through trichloroethylene (TCE) in the dewaxing vessel which is divided into number of separate compartments. From the last compartment the cloth passes through a solvent seal and heavy mangle where much of the solvent is removed from the cloth. The cloth then passes through a chamber into which steam is injected. Thus rapid evaporation of solvent in the cloth and the mixture of steam and TCE vapour is condensed and returned to the solvent seal where the solvent and water are separated.

Markal II process: The Markal II process consists of effecting simultaneous scouring and desizing by using suspension of enzyme in TCE and surfactant solution. The treated sample is then passed through steaming chamber for 10-20 sec. where the solvent is flashed off. The fabric is then given normal wash to remove the size. See **Markal I process**.

Markal III process: Markal III process combines bleaching with scouring and desizing by using emulsion of aqueous hydrogen peroxide in the TCE-surfactant solution, again followed by steaming and washing-off. See **Markal I process, Markal II process**.

Marceline: Also called Merceline. A light, thin silk fabric that is almost transparent. Used for lining hats and lightweight clothes.

Marcella: A fine cotton pique; used for Bedding.

Marduff: Native name in East Africa for stout, twilled gray cotton fabrics; used for tents, sails and native dresses.

Marengo: Suit and coat material (similar to fine Loden), not a fabric quality, only a colour description. This concerns very dark-coloured, almost black materials, which are brightened up by a small white component of 1–4% (= radial-line colour). The four-weave symmetrical twill is almost exclusively found as a weave. There are marengos both in worsted yarn warp and weft and in carded spun yarn in both thread systems.

Marengo yarn: Black and white mottled yarn, e.g. made of wool or silk (worsted or carded yarn).

Margherita: Italian embroidered, machine-made net.

Marie antoinette: Curtain, having applique sprays, flowers, and leaves of cord and tape.

Marine fibre: Poseidonia Australia, obtained from the bottom of the gulf in South Australia. The fibre is not very strong and is brittle when dry. It is believed to be New Zealand flax submerged and rotted in salt water. It has good affinity for basic dyestuffs, but acid, salt and sulphur dyes produce little result. This fibre has been discovered only lately and was experimented with as wool substitute for cheap clothing and rugs but no satisfactory result was obtained.

Marine stripes: Good quality English calico shirting of equal stripes in blue and white.

Marker: In the floor coverings industry, a distinctive threadline in the back of a carpet that enables the installer to assemble breadths of carpet so that the pile lays in one direction or so that patterns match.

Marking, in sewing: Marking is the transfer of various pattern symbols from the pattern to the fabric.

Marking chalks: Are used for marking/sighting piece goods in the finishing phase. Consist of dye pigments stored in wash-active substances. Should not be decomposed during operating processes before the piece washing (e.g. steaming, burning at high temperature, etc.); otherwise risk of dye fixation on the fibres.

Marking cotton: Cotton thread, usually dyed blue or red; used to embroider the outlines of a pattern.

Marking inks: Chalk dyes; Laundry markers, but also dyes, which are applied to yarns for labeling without being fixed properly. Must therefore be easily washed out.

Marking off in wet goods: Bleeding or destaining of colorations and printing in fabrics laying on top of each other in a wet or moist state.

Marketing: The business of selling goods, including advertising and packaging.

Marl effect yarn (Filament): Two single continuous filament yarn of different solid colour or dyeing properties (Subsequently dyed) doubled together.

Marl Single or two-ply: Yarn in England, used for filling; It is made in two coloured effect, usually one colour twisted around the other.

Marl yarn: See **Marled Yarn**.

Marled Yarn: Two different colour threads are spun together, not necessarily in equal quantities, to form a marled yarn.

Marmato: A medieval silk and gold brocade; said to be identical with arramas.

Marmot: A cheap fur from a small rodent. It is not used in its original state, but dyed to imitate more expensive furs, such as mink.

Marocain: See **Crêpe Marocain**.

Marocs: French woollen serge, of various qualities, made with a nap on the face.

Marquise: Finish High gloss imparted to fine cotton satins.

Marquissette: An open loose fabric spun in a fancy leno construction, or drop weave sometimes with spots or other designs included. It can be made from cotton, silk or wool, but is now mainly glass fibre nylon or polyester, orlon and made as a curtain fabric. A rayon Marquissette can be made in 20 x 20 to 70 x 50 with 75 to 150 denier yarn in warp and weft. An average nylon Marquissette has 70 denier semi-dull nylon in warp and weft, in 50 x 50 texture. Very lightweight, open, sheer, mesh fabric. Wears very well and launders very well. Comes in white, solid colours and novelty effect. Sometimes with a swivel dot or clip spot (marquissette). Uses: Window curtains, dressy dress wear, such as bridal parties or after 5 wear.

Married fibre clump: A defect that occurs in converter top. It consists of a group of unopened, almost coterminous fibres with the crimp in register.

Marron elastic fabric: An elastic fabric that is less than 150 mm (6 in.) in width.

Marry-muff: An old time coarse fabric worn by the common people in medieval England.

Marseilles: A stiff, double faced, quilted white cotton cloth, similar to pique, made in plain weave with large embossed patterns; used for shirt bosoms, men's vests, women's dresses, bed covers, etc.

Marseilles quilt: Marseilles quilt is a double cotton cloth, composed of two plain spun fabrics, one warp being the stitching warp and one weft a heavy

wadding filling. The figures are embossed, formed by Interweaving all threads with each other, but the two fabrics are not united at the ground.

Marseilles soap: Fatty, mild Soap made from olive oil, cotton oil, etc., white, or green, bar or needle shaped.

Marseilles work: Consisted originally of outlining flowers and other ornaments with stitches over a previously padded linen or canvas ground.

Marsella: Heavy, bleached, twilled linen, given a soft finish.

Marselles: A sort of figured pique, used for women's and children's clothes and for men's coats.

Marston: Commercial variety of late maturing cotton from Louisiana, the staple measuring up to 30 millimeters; the yield is 30–31 percent.

Martin: Commercial variety of late maturing, prolific cotton from Louisiana, the staple measuring 26–30 millimeters; the yield is 30 percent.

Martiniques: An 18th-century woollen fabric in England.

Masalia: Lightweight cotton fabric, spun in a twill, producing more effect. It is given a smooth, glossy finish.

Mascades: Silk cloth, used in Latin America as head cover.

Mascaret: Loosely spun, high finished worsted satin with spun figures.

Mashru: Fabric made of mixture of silk warp and cotton weft a style of weaving limited to Pathan, Mandvi and Surat in Gujarat, India for the use of orthodox Mohammedans. The fabric was developed as religious customs disallowed certain muslim communities from letting silk touch their body. The “double sided mashru” the term meaning ‘permitted’ was an intelligent way of wearing garment that had cotton inner and lavish exterior. Mashru is a heavy fabric with a satin glaze appropriate for winters and its characteristic patterns include bold, colourful stripes of various widths as well as pinhead sized dots assembled in floral or geometric pattern.

Masloff: Wide, stout, Russian woollen dress goods.

Mass: The quantity of matter in a body. Mass is determined in two ways: the *inertial mass* of an object determines its tendency to resist change in motion; the *gravitational mass* determines its gravitational attraction for other masses. The SI base unit of mass is the kilogram.

Mass colouration: (spin dyeing). In this process also called jet dyeing, finely distributed dye pigments, which withstand the thermal and chemical demands of the spinning process, are added to the spinning solution/melting of synthetic fibres. Used, for example, in polyamide for upholstery fabrics, carpets, floor

carpeting, automobile articles; in polyester for upholstery fabrics, menswear, work clothing.

Mass per unit length: Linear density of fibres and yarns.

Mass per unit volume: Picograms/litre of solution (pg/l), nanograms per litre of solution (ng/l), Micrograms per litre of solution (ug/l), milligrams per litre of solution (mg/l), grams per cubic metre of solution (g/m^3), etc.

Mass ratio: Milligrams/ 10^9 milligrams (ppb), Milligrams/ 10^6 milligrams (ppm).

Mass, commercial: See **Commercial mass**.

Massiru: Plain spun, light East Indian silk cloth; used for garments.

Mastic cloth: Embroidery canvas spun in alternate wide stripes of basket weave in cotton and waste silk satin.

Mat: A textile floor covering of predetermined shape and limited dimensions.

Mat Weave: See **Basket weave**, or **Hopsack weave**.

Matabie: General term in East India for all fabrics having spun or printed gold or silver patterns.

Matapalo: Fibrous bark, yielded by a species of fig tree in Peru; used for garments by the Indians.

Matching Process in wool sorting: Consists in grouping the parts of corresponding quality from various fleeces.

Matchings: The different sorts of wool into which the fleece is divided in wool sorting.

Matelasse: French for “cushioned or padded or quilted”. A pooching or quilted effect fabric. Figured made on jacquard or dobby loom, in double cloth weave. In one type, the cloth consists of warp and weft with an extra weft, used as a padding and held in place by an extra stitching warp. The back of the cloth is a fine, loosely spun web of warp and weft interlacing. The fabric is made on a dobby or a jacquard loom. The fibres used may be silk, viscose, acetate, nylon, polyester or combinations. The fabric also may contain metallic threads. The pattern stands out and gives a “pouch” or “quilted” effect to the goods. Crepe yarn in double weave shrinks during finishing causing a blistering effect. in upholstery, coarse yarns cause blistering. Comes in colours, novelty effects, and some with metallic yarns. Gives good wear and drapes well. If washable, it must be laundered with care. It is very attractive and suits quite plain styles. Uses: Some cotton matelassé used for bedspreads, dresses, suits, ensembles.

Material Balance: A mathematical representation of material flow through a reaction system. The input material is accounted for throughout its various transformations.

Material, textile: Fabric, material, e.g. dyeing material, cleaning material, textile material; should always be regarded as fibre loading in the technical finishing sense.

Mathematical model, statistics: An equation or set of equations that describes a system.

Matheson: A Highland tartan, composed as follows: Wide red field, split in the center by a group of five dark green stripes, of which the middle one is much heavier, each pair on the side being fine lines; *dark blue stripe about one-eighth of the red field; dark green stripe (as wide as the blue) split in the center by a pair of narrow red lines; red stripe, somewhat narrower than the blue; two narrow green and red lines alternating; dark blue stripe, as above*; dark green stripe, twice as wide as the blue, divided into three equally wide parts by two narrow red lines; repeat in reversed order, group described between two*.

Matrimonio: Soft finish, bleached cotton bed sheeting in Venezuela; about 52 inches wide.

Matrix: A descriptive term for a textile fibre in which one or more polymeric fibrous material(s) is dispersed in another.

Matrix fibre: (1) A manufactured fibre that is essentially a physical combination or mixture of two or more chemically distinct constituents or components combined at or prior to the time of extrusion (i.e., produced in fibre form), which components if separately extruded would each fall within different definitions of textile fibre. (FTC definition). Matrix fibril fibres have the fibril constituent randomly arranged across the cross section of the matrix. When the fibril component is in high concentration it may actually form a fibrillar network in the matrix. (2) In aerospace textiles, a thermoplastic fibre used with reinforcing fibre to form a composite after consolidation with heat and pressure. (3) In nonwovens manufacture, fibres that are blended with low-melt fibres to form a thermally bonded fabric.

Mats: Pile-free, usually braided or spun underfloor coverings made of bast fibres. Also made of gum, plastic and fine metal filaments as door models.

Matt effect: See **Basket weave**.

Matt jersey: A jersey fabric of almost any weight with a dull surface due to the fact that it is knitted from crepe yarns.

Matt white printing : Printing using pastes, which contain white pigments and binders. Often used on dyed material.

Matta: Short staple cotton grown on the lowlands around Pernambuco, Brazil.

Matter, extractable: See **Extractable matter**.

Matthews: Commercial variety of very prolific, long staple, early maturing American cotton; the staple measuring 35-40 millimeters; the yield is 29 per cent and above.

Mattis: Late maturing commercial variety of American cotton, the staple measuring 25-30 millimeters; the yield of lint is 30-32 per cent.

Mature cotton: Cotton whose fibre wall has thickened to an acceptable level.

Mature fibre, Cotton: Self explained. (1) A mature cotton fibre treated with caustic soda solution – Fibres that have swollen into unconvoluted and almost rod like shapes where total wall width is equal to or greater than the lumen width. (2) Cotton fibres observed under polarized light: Fibres that appear yellow, yellow green or green and are yellow or light yellow upon rotation to the subtractive position (thro' 90°) and show little or no parallel extinction on removal of selenite plate.

Mature fibres: (cotton fibres observed under polarized light)- fibres that appear yellow, yellow green, or green and are yellow or light yellow upon rotation to the subtractive position (through 90°) and show little or no parallel extinction on removal of the selenite plate.

Maturity, cotton: An important cotton fibre characteristic which express the relative degree of thickening of the fibre wall. It is sometimes defined as the ratio of the cross sectional area of the circle having the same perimeter as that of the fibre, or the ratio of average wall thickness to the radius of the circle having the same perimeter as that of the fibre. However, in practice, direct measurement of the degree of the wall thickening is seldom carried out and the average maturity of a given of a given sample of cotton is by one or more of several indirect tests which are often used to discover the proportion fibres having a maturity greater than some selected level.

Maturity index: Relative indication of cotton fibre maturity. See **Goldthwait test**.

Maturity, Cotton, test for: See **Goldthwait test**.

Maubois: French droguet made of silk.

Maud: Obsolete term, but it used to describe checked woollen traveling rugs spun in different shades of grey.

Mauritius fibre; Mauritius hemp: A fibre from the leaf of the plant *Furcraea gigantea*.

Mauritius hemp: Trade name for the strong leaf fibre, yielded by the *Furcraea gigantea* in 'Mauritius (aloe fibre), Brazil (pita fibre), Central America (fique fibre), West Indies and East Africa inter alia; used for cordage, gunny bags; similar to sisal.

Mausari: Thin, open face but coarse cotton fabrics, made in India; used for mosquito netting. Generally made in check pattern.

Mauveine: (aniline purple), first synthetic (cationic) dye, which the then 18 year old Perkin discovered by chance in 1856 (called aniline purple, later mauveine, Perkin's mauve, Perkin violet) and a few years later industrially manufactured on a large scale, whereby he also thoroughly understood how to solve the application problems

Mawata: Silk cocoons that have been simmered and opened onto a wooden frame.

Maxey: Commercial variety of prolific American cotton, the staple measuring 30–35 millimeters; the yield is 30–32 per cent. Also called Meyers Texas.

Maximum pick up: More than 100% of liquor application (compare: Low wet pick-up; Addition high-wet pick-up). Using special machines, (see Fig.), a fabric is loaded with as much liquor as it can just carry without dripping before it then, for example, goes into a steamer.

Dry fabric with high we pick up out

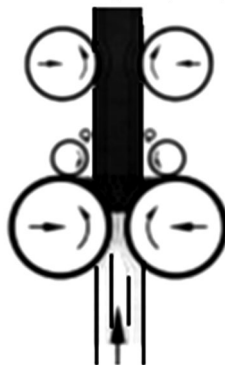

Dry or we fabric in

Maxwell: A Highland tartan, composed as follows: A wide green stripe, split by a red stripe in the center; on each side of green stripe, and separated from it by a red stripe is a black stripe, about one-fifth the width of the green stripe;

a red field (as wide as the group measured between the outer edges of the two black stripes), split in the center by a pair of narrow green lines.

Mayenne: A fine, bleached French linen.

Mayo twill: See **Campbell twill**. Name for a twill, producing short, zigzag figures in alternate colours.

Mazamet wool: Sweated wool from Southern French town of Mazamet, where most Australian sheepskins come to be processed.

MBAS, MBS: Methylene blue active substances.

MBF: A moving bed sand filter.

MBBR: A moving bed biological reactor.

MBR: A membrane bioreactor, but can also mean a moving bed biological reactor.

MBT: Mechanical biological treatment.

MCB: Monochlorobenzene.

MCL: Maximum contaminant level.

MCPA: See **Chlorophenoxyacetic acids**.

MCLG: Maximum contaminant level goal. See **Maximum contaminant level**.

MDPE: Medium density polyethylene.

MDR: Multiple drug resistance.

MDTOC: Minimum detectable threshold odour concentration.

MD: Modal fibre.

MDI: Abbreviation for diphenylmethane diisocyanate or diisocyanatodiphenylmethane.

MDPE: See **Medium Density Polyethylene**.

ME: Metal fibres.

Mean: Average.

Mean deviation unevenness, in textiles: The average of the absolute values of the deviations of the linear densities of the integrated lengths between which unevenness is measured and expressed as percentage of the average linear density for the total length within which unevenness is measured.

Mean Fibre Diameter: The average diameter (thickness) of a group of fibres from an animal.

Mean length, in cotton: The average length of all the fibres in the test specimen based on weight length data.

Mean length, in testing of cotton fibres: The average length of all fibres in the test specimen based on mass length data.

Mean temperature, in thermal transmittance of textiles only: The average of the hot plate temperature and the temperature of the calm, cool air that prevailed during the test.

Measurement process: The act of quantifying a property or dimension.

Measurement value: The numerical result of quantifying a particular property or dimension.

Measure cutting: The cutting of a garment to individual measurements.

Measuring Gauge: Used to mark even widths for hems, pleats, etc. It is available in chart paper and can be made at home in different widths.

Mechanical dewatering of sludge: Dewatering of sludge that uses a mechanical device such as *belt filter press*, *centrifuge*, *filter plate press*, tube press, vacuum filter, etc. For wastewater sludges, belt filter presses and centrifuges are common. The filtrate from the dewatering of wastewater sludge can have a high BOD. Dewatering of raw wastewater sludge is very malodorous. Waterworks sludges are difficult to dewater and filter plate presses are often chosen.

Mechanical filtration: This may mean one of several things: *mechanical dewatering of sludge*, *microstraining*, use of a *pressure filter (2) or screening*.

Mechanical finishing: Changing the appearance or physical properties of a fabric by a mechanical process such as calendaring, embossing, bulking, compacting, or creping.

Mechanical finishing: Mechanical finishing processes can be referred to as those processes generally carried out on open-width dry fabrics, with or without heat application, which give the fabric good dimensional stability (shrink proof and shape retention) and modify the “hand” of the textile product by altering its structure (at least its surface structure) Dry finishing

Calendaring: a lustrous, dense and compact appearance can be obtained by means of friction, pressure and heat.

Ciréing: this calendaring operation is carried out using special calendars and exploiting the combined actions of heat, friction and polishing agents.

Embossing: this particular type of calendaring process allows engraving a simple pattern on the fabric.

Sueding: thanks to this process, the fabric has a much softer hand and an improved insulating effect thanks to the fibre end pulled out of the fabric surface. This process is carried out by means of a roller coated with abrasive material.

Raising: the fibre end pulled out to the fabric surface imparts an insulating effect. This process is carried out by means of hook-needles running in different directions on the fabric.

Shearing: the fibre ends on the fabric surface are cut by using special cutting tools.

Singeing: the fibre ends pulled out to the fabric surface are burnt by means of a flame (see **preliminary treatments**).

Mechanical flocculation, in ETP: A common method of flocculation, capable of improving

the clarity of raw water or wastewater by the gentle movement of a picket fence stirrer or of paddles at speeds of the order of 70 mm/s for 15 minutes. It is usually used after coagulation and then followed by clarification or dissolved air flotation.

Mechlin lace: A soft, filmy lace in which even the denser decoration is filmy. Often used for bridal veils.

Mecklenburgh: (1) 18th century woollen fabric in England, sometimes made with silk flowered patterns; (2) Stout English wool damask. The ground is of colored hard twist warp stripes with colored flower patterns.

Me-Complex dyes: See **Metal complex dyes**.

Mecomba: Native East African name for the cloth-like bast, obtained from the (*Brachystegia* tree; used by the natives for clothing).

Med fibre: A medullated animal fibre in which the diameter of the medulla is less than 60% of the diameter of the fibre.

Median, for a series of observations: After arranging them in order of magnitude, the value that falls in the middle when the number of observations is odd or the arithmetic mean of the two middle observations when the number of observations is even.

Median load, in tensile testing: That load level that is exceeded by half the recorded peaks and which in turn precedes the other half of the recorded peaks, in a specified distance of cross-head travel.

Medium density polyethylene, m. d. polythene, MDPE: A thermoplastic plastic which has a density of between 0.945 to 0.955 g/cc, which is lower than

high density polyethylene (HDPE), but greater than low density polyethylene. It is light and flexible. It may be used for landfill liners but HDPE is more common. MDPE can be used for irrigation pipes, but water pipes and sewers normally use HDPE. MDPE is sometimes used for sliplining as a water pipe rehabilitation technique.

Medallion lace: Motifs are cut or made from a piece of heavy lace and inserted into the cloth. Used for lingerie, table cloth etc.

Medalloion carpets: These carpets have perfectly circular or elliptical motif on self-coloured primary backing in the centre of the carpet. Similar designs can be found along the edge of the carpet or in the corners.

Medical clothing: Medical clothing functions as telemedicine that provides real-time feedback to wearers, and alerts bystanders, if necessary, by applying a sensor or microchip to the clothing or textile product. It can be used to monitor the user's individual heartbeat rate, respiration rate, and temperature, or to record a soldier's wound status in a war, etc.

Medicis: French bobbin lace, similar to the Cluny.

Medium Wools: Usually 1/4, 3/8, and 1/2 blood wools, OR wools grading 50's to 62's, OR wools with a 24 to 31 micron count.

Medley cloth: A mixture cloth, dyed in the wool, originated in the early part of the 17th century in England.

Medulla, in mammalian hair fibres: The more or less continuous cellular marrow inside the cortical layer in most medium and coarse fibres.

Medullated fibre: An animal fibre that in its original state includes a medulla.

Meherjun: Coarse Persian carpet wool.

Meisen: A plain-weave lightweight Japanese Silk, with a blurred pattern achieved by colouring the yarn before weaving them. Used for blouses dresses.

Mercerised yarn: Instead of Mercerising in fabric form, in certain cases the yarn is mercerized and made into fabric, most frequently in knitted form. The method is much costlier than the fabric mercerizing, but the mercerizing effects are usually better as in the yarn form mercerisation more complete due to better absorption of caustic soda.

MEK: Max. permissible concentration of harmful emissions in the exhaust air. Can be determined on the basis of the Maximum emission concentration, in view of the chimney height. So an MEK of ca. 40 kg/h of trichloroethylene or tetrachloroethane and 50 kg/h of benzene is produced from an exhaust gas conduction height of, e.g., 10 m.

Melamine/Formaldehyde: Melamine can react with up to 6 moles of formaldehyde to form a variety of products. Commercially, trimethylol and hexamethylol melamine are the more important condensates. In storage, the hydroxymethyl (N-methylol) groups tend to polymerize and liberate formaldehyde. By converting them to the methoxymethyl derivative, the shelf life is much improved. Most of the commercial products are methylated.

Melange: (1) French for mixture effect; (2) Yarn spun from printed top; (3) Colour effect on fabrics spun from such yarns.

Melange flocking: Flocking or flock printing using blended flock material.

Melange yarn: Mélange yarn made of bleached/unbleached or treated/untreated fibres, which only appears mottled after dyeing.

Melange' yarn: Yarn made from dyed fibre and undyed fibre to get the melamine effect. The same effect can be brought by mixing two classes of fibre and making into yarn (a blend) and dyeing one component also, but this is possible in case of blended yarn only.

Melded fabric: A nonwoven fabric of a base fibre and a thermoplastic fibre. The web is hot-calendered or embossed at the softening point of the thermoplastic fibre to form the bond.

Meles Rugs: Small, coarse, all-wool rugs made in Asia 'Minor; the loose and short pile is tied in Ghiordes knot. Very bright reds, blues and yellows are usually used in a great variety of designs. The sides and ends are finished with a selvage and there is a fringe at the ends.

Melt: A material in the molten state.

Melt blend: See **Biconstituent fibre**.

Melt blowing: A process in which a polymer is melt extruded through a dye into a high velocity stream of hot air which converts it into fine and relatively short fibres. After quenching by a cold air stream the fibres are collected as a sheet on a moving screen.

Melt flow Flow rate: Melt index measured at 125°C.

Melt index: The weight in grams of a thermoplastic material that can be forced through a standard orifice within a specified time.

Melt spinning: Some polymeric fibres are spun by melting the polymer to a liquid state. The liquid is forced through the spinner opening under pressure and cooled by a jet of air to form the filament. Melt spinning requires no chemical reactions and no solvent recovery system.

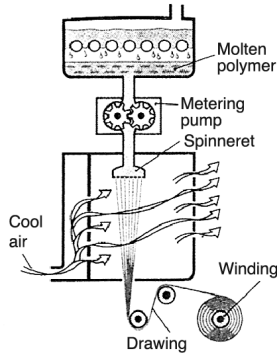

Melt Spinning (schematic)

Melt Strength: Ability of plastic to hold the die shape.

Melt Temperature: Temperature of plastic in an extruder.

Melt viscosity: The resistance of molten polymer to shear deformation. It is primarily a factor of intrinsic viscosity and temperature. It is an apparent polymer viscosity measurement in that it is only true at a specific shear stress and shear rate combination.

Melt-dyed: Synthetic fibres dyed in the melted form during melt spinning.

Melt-fracture: An unstable melt spinning condition in which the surface of the extrudate become rough and irregular.

Melting, in testing thermal protective clothing: A material responds evidenced by softening of the fibre polymer.

Melting point: The temperature at which the solid and liquid states of a substance are in equilibrium; generally, the temperature at which a substance changes from a solid to a liquid.

Melton: A firm medium weight wool cloth in a close plain weave, with a felted nap but not one way nap. It is dull in appearance and comes in white and all men's suiting colours. Rigidly constructed, it is dull, and lusterless and finishing treatments cover up all the interlacings and warp and wefts. It used to be coating fabric, but now it is mainly used as an aid to tailoring, because it does not dray, it is full of backing collars, as the raw edges can be used to reduce bulk. Mostly used for men in overcoating, uniform cloth of all kinds (army, navy, etc., as well as police and firemen), pea jackets. Also used for heavy outer sports garments and coats for women.

Meltonette: A lightweight fabric, which resembles Melton cloth, and is used for women's wear.

Membrane: (1) A skin. A membrane filter is consequently one of skin thickness, but the term usually means a polymer membrane as used in a membrane process. Compare membrane filtration; See **semi-permeable membrane**.

(2) A highly engineered polymer film containing controlled distribution of pores. Membranes act as a barrier permitting the passage of material only upto a certain size, shape and character. Membranes are used as the separation mechanism in reverse osmosis, electrodialysis, ultra filtration, nanofiltration, and microfiltration, as disc filters in laboratories, and as pleated final filter cartridges, particularly in pharmaceutical and electronic applications.

Membrane biological reactor, Membrane bioreactor, MBR : A biological treatment process for wastewater where a membrane process (typically microfiltration or ultrafiltration) is used for separation of the treated effluent from the biomass in the bioreactor. The effluent should contain no suspended solids or micro-organisms, such as bacteria. The membrane separation unit may be separate from, or immersed in the bioreactor. In the separate system, membrane fouling can occur due to the biomass coating the outside of the membrane. Air bubbles on the outside of the membrane or backwashing through the membrane or chemical flushing through the membrane are processes used to minimise membrane fouling. The bioreactor is typically an activated sludge plant, but the bioreactor may be an anaerobic process (membrane separation anaerobic treatment), in which case no air bubbles are used in the bioreactor.

Membrane filtration: (1) A method of direct counting of coliform or other bacteria in water. A measured diluted volume is filtered through a membrane of pore size small enough (0.45 μ m) to hold back bacteria. The membrane is then incubated face upwards in a selective medium at a suitable temperature and after 18 h the colonies that have developed are counted. As in the most probable number method, these counts are only an estimate. Counting is done under a hand lens and suspect colonies can be transferred to liquid or solid medium for confirmation of their properties. Membrane filters are also used for sampling algae or for concentrating bacteria from a water in which they are known to be scarce—e.g. a drinking water, where the expected count is less than about 30 bacteria per ml. Techniques such as bioluminescence and fluorescent staining can be used to adapt membrane filtration to a more rapid detection method. (2) The use of a membrane process to treat water or wastewater.

Membrane fouling: Membranes used in reverse osmosis (RO) or nanofiltration should last 5 years. However, the membrane may become

fouled by suspended matter or bacteria growing on its surface. The inlet water may require treatment (e.g. coagulation, filtration and disinfection) prior to RO or nanofiltration. Polyamide membranes used in RO can be attacked by chlorine and so excess chlorine must be removed i.e. dechlorination. Salts may precipitate on the salty side of the membrane due to concentration polarisation. This also causes membrane fouling.

Membrane processes: Various processes use **semi-permeable membranes** to hold back salts or fine solids or pathogens in order to remove these components from water or wastewater. **Reverse osmosis** is a popular method for **Desalination**. **Microfiltration**, **Nanofiltration** and **ultrafiltration** can be used in water and wastewater treatment for the removal of colloids or colour or pathogens. **Electrodialysis** uses membranes plus a voltage and can be used for desalination. See **Concentration polarisation**, **Ion exchange membranes**, **Membrane fouling**, **membrane biological reactor pervaporation**.

Men chijimi: Cotton crepe in Japan.

Mende: Fine, smooth French serges of various grades; used for lining.

Mending: A process in spun fabric manufacture in which weaving imperfections, tears, broken yarns, and similar defects are repaired after weaving; especially on woollen and worsted fabrics to prepare them for dyeing, finishing, or other processing.

Mending: A finishing process in cloth manufacture in which weaving imperfections, tears, broken yarns, etc. are repaired after the cloth is taken from the loom. Largely done on woollen and worsted fabrics, to prepare them for further finishing.

Menhofu: Cotton duck in Japan.

Menin lace: Bobbin lace, similar to the Valenciennes with the threads of the mesh ground twisted three and a half times. See **Valenciennes**.

Menneru: Trade term in Japan for flannelette.

Menouffieh: Variety of Egyptian cotton, having a good, silky staple.

Menzies: A Highland tartan, composed as follows: Wide red field; "two white stripes with a narrower red between, the group being about one-third the width of the red field; red stripe, as wide as a white and the red stripe together in the previous group*"; "White stripe (as wide as the just mentioned red stripe and the group together) split near each end by a narrow red line; repeat, in reversed order, the stripes mentioned between the two *.

Meraline: Narrow-striped, all-wool dress goods in England.

Mercer, John: Inventor of Mercerisation process for cotton. See **Mercerisation**.

Mercerisation: Treatment of cellulosic textiles in yarn or fabric form with a concentrated solution of sodium hydroxide whereby the fibres are swollen, the strength and dye affinity of the material are increased and their handle is modified; named after its inventor, John Mercer Mercerizing cotton can significantly improve its dye uptake, especially if there are immature fibres present (1844). The additional effect of enhancing the lustre by stretching the swollen material while wet with caustic and then washing off was discovered by Horace Lave (1889). “Slack” mercerizing, which does not require tension, but causes the fabric to shrink, can be done at home, but requires a great deal of care because of the caustic used. Typically it is done using about 20% to 25% sodium hydroxide solution at around 20°C. Fabric becomes very stiff and hard to handle until the solution is all washed out. In industrial practice, in chain mercerizing shrinkage of the fabric is allowed followed by re-stretching and washing on a clip stenter. In chainless mercerizing the fabric is effectively prevented from shrinkage by transporting over rotating drums/rollers.

Mercerised: Fabric or yarn which has undergone the Mercerisation Treatment.

Mercerising: The process of mercerization treatment.

Mercerization: See **Mercerisation**.

Mercerizing: See **Mercerising**.

Mercerising machine; Mercerising plant : The Machine used for mercerizing. Mainly there are two types. (a) Chain mercerizing machine. (b) Chainless mecerising Machine. The main defference is in the satabilisation zone, the other areas like impregnation and washing off zone remains similar, in the former stabilization is done on chain and in the latter stabilization is done on Rollers where the fabric is not allowed shrink by transporting the cloth from Roller to roller giving no chance to shrink. Chain mercerising machine occupies larger space and costlier, while the chainless merceriser occupies less space and cheaper.

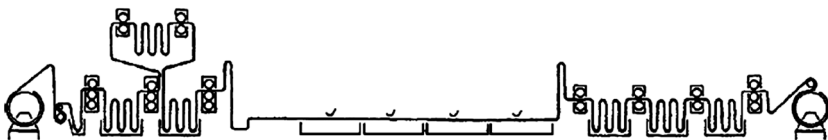

Schematic drawing of chain mercerizing plant, consisting of two impregnation sections with interconnected draw zones. Chain stabilization section with subsequent washing plant.

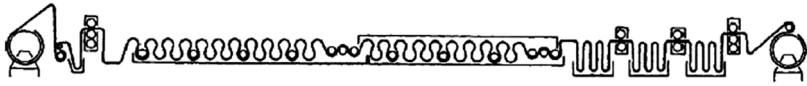

Schematic drawing of chainless Mercerizing plant, consisting of mercerizing section and stabilization section with connected cloth guide and subsequent washing plant.

Mercerized wool: Wool is treated for a brief period at a low temperature in an 80 degree Tw. solution of caustic soda; this gives a high lustre to the wool and strengthens it, but the fibre cannot be felted after.

Merezhiki: All-white hand embroidery over linen, made by the peasants in Ukraine.

Merge: A group to which fibre production is assigned based on properties and dyeability. All fibres within a merge can be expected to behave uniformly, and for this reason, can be mixed or used interchangeably.

Merchandise: Goods for sale.

Merchandise beam: Same as Cloth roller, see Cloth fell.

Merchandising: Having the right goods of the right quality at the right time, in the right place, in the right quantity, at the right price.

Merchant converter: A supplier of finished fabric who buys loom-state material and commissions its further processing.

Machine gauge: The number of needles on a knitting machine per unit of length (usually this unit length is an inch).

Merino: From pure-bred merino sheep mostly from Australia and South Africa. It gives the finest grade, soft, expensive wool fleece. .Note: Merino wool usually has a fibre diameter of 24µm or less. The wool is used in good quality cloth, blankets etc. Sometimes mixed with other wool to reduce the price.

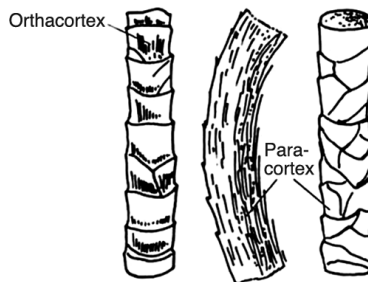

Typical appearance of the merino fibre

Merino: (1) Wool from purebred Merino sheep. Merino wool usually has a mean fibre diameter of 24 microns or less. (2) A yarn of blended wool and cotton fibres.

Merino extrafine wool: A highly refined and superbly soft yarn. Used alone or mixed with other luxurious yarns such as silk, alpaca, cashmere.

Merletto: Italian for lace.

Merveilleux: (1) Diagonal silk lining, given a lustrous finish; (2) A very fine and heavy silk satin, with a twilled back.

Mesh, in coated glass yarn fabrics: The number of warp yarn or ends per linear 25.4mm (1 in.) followed by the number of filling yarns or picks per linear 25.4 mm (1 in.)

Mesh (1): The open spaces in nets, knitting, crocheting and lace.

Mesh (2): Netting fabric, plain or printed, with holes from 3mm (1/8 in.) to 1 cm. (3/5 in.). Some are made from cotton, others from polyester. Used for tops and vests.

Mesh fabrics: A broad term for fabric characterized by open spaces between the yarns. Mesh fabrics may be spun, knit, lace, net, crochet, etc.

Mesh fineness: For the labelling of the fineness of Screen mesh materials, are used for different systems depending on material: silk bolting cloth (screen silk): numbers 0–25 (8–16 for fineness of 50–200 stitches per inch; 8–11 for normal design; 11–14 for sharp contours and 15–16 for the finest half-tone drawings). Phosphor bronze: mesh fineness lie between 90 and 350 threads per inch (110–180 as normal fineness, 200–350 for the finest designs). Synthetic fibre threads: labeling according to threads/cm (12–200).

Mesh number: Parameter for screen mesh, which indicates the number of openings/inch (= 2.55 cm), is however only meaningful using the diameter of the individual openings (see Fig.). As with constant mesh number the screen throughput is proportional to the opening diameter; besides the mesh number the screen manufacturer publishes a whole series of additional information, such as:

- hole diameter,
- number of holes per cm²,
- throughput in %,
- type of hole distribution,
- vertical and horizontal hole geometry.

Mesh sizes: The mesh numbers used in the past to describe sieve openings indicated the number of holes (or wires) per lineal inch; thus, a higher number

had smaller openings. The diameter of the wires affects the hole size. Sieves therefore are now defined by the size of opening and the wire diameter in mm.

Meshtester: Device for measuring rotary screens for screen printing with regard to manufacturing-related differences in the open area.

Meshhed rugs: Medium and large sized all-wool Persian rugs with medium long pile tied in Ghiordes knot. The design has usually very large palm leaves placed diagonally and also animal forms. Deep blue and red are the characteristic colours.

Meshi: In the Bible means silk.

Messaline: The name has come from Messalina, wife of Emperor Claudius. She wore a great deal of plain soft silk and this type of fabric was named after her. It is a lustrous, soft, silky fabric in a satin weave, usually in plain colours. It may now be polyester, acetate, triacetate, as well as silk fibre. This is an expensive silk, which drapes well, and is perfect in black for special occasion dresses.

Mestiza: South American name for merino wool yielded by the cross of pure merino and the native creola sheep.

Meta: A chemical prefix, usually abbreviated *m*, that denotes that two substituents on a benzene ring are separated by one carbon atom.

Metachromasy: Property of certain dyes to show a different shade depending on concentration, aggregation, solvents and substrate. If, for example, you place an alcoholic solution of pinacyanol in sufficient concentration in a reagent glass here, this appears dark red. The thin layer, which flows down on the glass walls after the solution is tipped out, is, however, blue. This is a result of different strengths of absorption of different wavelengths of light by the dye. Red is not noticeably absorbed. The strongest absorption of the dye is in the orange parts of the spectrum at about 605 nm. The absorption subsides in the shorter wavelength range, but is still strong enough that with sufficiently large layer density or concentration the eye can no longer distinguish light let through here. So only red light is let through. By reducing the layer density, green and blue rays still have an effect on the eye as well, which results as the colour effect of blue.

Metal cast button: A button produced by the casting of molten metals and metal alloys into single cavity or multiple cavity moulds.

Metal complex dyes 1:1 Type: See **Metal Complex dyes.** Among these dyes primarily the 1:1 chromium complexes containing sulfonic acid groups have achieved commercial importance.

They must be applied from a strongly acid bath, which imposes certain limits on their range of applications. The 1:1 metal complexes are not suitable for polyamide, which is partially decomposed under the dyeing conditions for these products. Their main area of application is in the dyeing of wool, but they are also suitable for leather dyeing.

Metal complex dyes 1:2 Type: See **Metal Complex dyes**. Because of their structure 1:2 metal-complex dyes exhibit anionic character. Those which have gained commercial importance are primarily the ones that are free of sulfonic acid groups and for which adequate water solubility is provided by nonionic, hydrophilic substituents, such as methylsulfone or sulfonamide groups. The introduction of 1:2 metal-complex dyes which are applied from a neutral to weakly acid bath, represented a significant technical advance over the strong-acid-dyeing 1:1 chrome complex dyes. It has led to better protection of the fibre material, simplification of the dyeing process, and improvement of the fastness properties.

1:1:1 metal-complex dyes: Mixed complexes made from one coloured, one colourless component and one metal central atom (variation from 1 : 2 complex).

1 : 2 metal-complex dyes, Dispersed: These dyes do not contain any water-soluble groups and are applied as disperse dyes on polyamides. Good light and wet-fast, building up to the deepest tones. Tendency to streaky dyeing in brighter shades. Usually dull tones.

Metal complex dye: (or metallized dye) – dye in which typically one or two dye molecules form a close permanent association or “complex” with a metal atom. The metal associated with the dye is held by what is more or less electrical charge attraction of more than one part of the dye molecule for the electrons of the metal atom. The metal is often copper, chromium or cobalt. There six types: 1 : 1 metal-complex dyes;, 1:1:1 metal-complex dyes, 1 : 2 metal-complex dyes, Dispersed 1 : 2 metal-complex dyes, Pre-metallized direct dyes, Phthalogen metal-complex dyes.

Metal detecting device: Device for the local monitoring (detecting) of the smallest particles of leading metals to prevent damage to calendar bowls and shearing blades. Used at fabric speeds up to 400 m/min.

Metal embroidered lace: A lace fabric as base, usually of viscose, with embroidery worked in nylon an metal yarns.

Metal fibres: (MTF, ME), textile processed metal filament and staple fibres. Recently spinnable cut forms of metal filaments or Metallized yarns, e.g. up

to 5–15% compared with other long staple fibres in fashionable glitter effect yarns. Metal filaments are manufactured from high-grade steel filaments in the nozzle extraction process. Uniformity, high strength, abrasion resistance, electrical conductivity, temperature resistance, low extensibility. Chiefly used as an addition, e.g. in carpet yarns; prevents electrostatic charge. After sizing, 100% yarns can be processed in weaving and knitting. Steel filaments are, e.g., used for tyre cord.

Metal foil printing: Works according to the transfer printing technique. Fabrics are firstly pre-printed with adhesive and afterwards treated together with the metal foil in a transfer calendar

Metal powder printing: Earlier days it was generally called bronze printing because bronze powder was the main metal powder used in printing. Now, metal printing is basically designing technique for the manufacture of gold, silver and graphite printing effects in hand block, screen, spray or roller printing. Precursor of Pigment printing. Fixation of metal powder usually with aqueous plastic dispersions.

Metal salts in DP finishing: Magnesium chloride is a mild catalyst that can be used at high temperatures. It is non-corrosive and presents the fewest side reaction problems, e.g. shade change, fibre damage etc. Zinc nitrate and zinc chloride are more reactive than magnesium chloride. Zinc presents effluent disposal problems. Zinc nitrate cause dye shade changes.

Metal thread fabrics: There are a few fabrics, for example Silk from the east, which have real silver or gold threads spun into them. The problem with these is that the thread tarnishes. Normally advised to keep the garments in tissue paper to reduce the action of the atmosphere.

Metal-complex Dyes: See **Metal Complex Dyes.**

Metallic fibre: A manufactured fibre composed of metal, plastic-coated metal, metalcoated plastic, or a core completely covered by metal (FTC definition). They are available in “yarn” form as well as in staple form for spinning with other fibres. A core yarn with a metal surface is produced by twisting a strip of metal around yarn of natural or manufactured fibres.

The most important characteristic of metallic fibre and the chief reason for its use in textiles is glitter. Metallic fibres are used as a decorative accent in fabrics for apparel, bedspreads, towels, draperies, and upholstery. A relatively new application for metallic fibres is in carpet pile, where they are being used in small percentages for control of static electricity.

Metallic yarn: See **Metallised yarn.**

Metallisable dyes: See **Dyes**.

Metallised yarn: From a textiles point of view, it is more correct to say Metallized yarns.

Metallised yarn; Metallic yarn: A yarn which has fine metal as a component. Note: There are several types, the best known of which are: (a) Yarns in which separate metal fibres metal fibres or filaments are included (b) Metal of narrow strip section usually lustrous. The metal may be coated with film such as viscose, cellulose acetate, butyrate or polyester. The film may be coloured. (c) Yarn on which metal is deposited e.g. by chemically, or by electric arc or by adhesive (cf. tinsel yarn) (d) multiend yarns in which at least one single yarn is metallic.

Metameric colour match: A colour match between two materials in which the colors are identical under some lighting conditions but not under others. Metameric colour matches are common when different pigments or dyestuffs are used to colour the two materials.

Metameric index: Two samples, which, for example, have the same colour in daylight, possibly have a different colour when the illumination is changed, if they have different spectrum reflection curves and are therefore metameric. A metameric index is used for the quantitative labelling of this undesirable property, e.g. in order to discover the sample which shows the smallest metamerism, when comparing several colour recipes for the post-dyeing of a pattern. If both samples do not have a colour difference in daylight D65 ($\Delta E = 0$), the metameric index of this sample pair for an illumination change from D65 to another light source is equal to the colour difference of the samples in this other light source.

Metamerism: A phenomenon exhibited by a pair of colours that match under one or more sets of illuminants (be they real or calculated), but not under all illuminants. Or A marked change in the colour of an object with a change in the spectral composition of the light by which it is viewed. NOTE: Metamerism can be judged only with reference to the changes occurring in other objects in the fields of view as the illumination is changed.

Metameric match: A colour-match that is judged to be satisfactory under a particular illuminant but not under other illuminants of different spectral composition.

Metap weave-knit Process: A technique combining weaving and knitting in one operation with two independent yarn systems wound on warp beams. In the fabrics produced, spun strips are linked together with wales of stitches. Generally, the fabrics have 75-85% spun and 25-15% knitted structure.

Meter: See **Metre**.

Metering: The term “metering” in wet finishing is understood to mean the addition of a given quantity of solid or liquid active material to a liquid treatment medium (dye or treatment liquor) over a period of time (metering time). According to this definition, the term “metering system” covers the metering volume, metering concentration, metering mechanics, metering curve as well as the type and composition of the metered substances.

Metering pump, in spinning: A positive displacement device that pumps a measured amount of polymer solution to the spinnerets.

Metering station: Plant for the metering of particular quantities of dye and chemicals. Supplied as a ring main via mixing station or metering unit directly to the dyeing plant.

Metering Zone, in melt spinning: Section of extruder controlling rate of flow into die.

Methacrylic acid - Ethyl acrylate co-polymers: Monomers containing carboxylic groups can be polymerized with vinyl and acrylic co-monomers to yield a range of co-polymers with varying carboxyl content. Co-polymers of methacrylic or acrylic acid and ethyl acrylate have been found to be particularly useful as soil release agents. An acid content of 70% or less give relatively high molecular weight emulsion polymers whereas higher proportions of acid renders the polymer water soluble and of lower molecular weight. A particularly good combination for soil release is 70% methacrylic acid and 30% ethyl acrylate. The data shows that when a 70/30 MAA/EA co-polymer is added to a typical durable press finish containing DMDHEU, the fabric possesses excellent soil release with fair durability.

Methenamine Pill Test: See **Flammability test**. Flammability test using a methenamine pill.

Methine dyes: Methine dyes and polyene dyes are characterized by a chain of methine groups that forms a system of conjugated double bonds.

Methylhydrogen fluid silicones: Methyl hydrogen dichlorosilane offers a route for making a linear polysiloxane fluid with latent crosslinking potential. Hydrolysis of the dichloro groups will occur rapidly with water to form a linear polymer. Stable emulsions can be prepared, as long as the aqueous pH is maintained between 3-4. When these emulsions are applied to a fabric with a tin catalyst (e.g. dibutyltin-dilaurate), the Si-H group hydrolyzes to the silanol and condenses to form a crosslink. These offer a way of improving durability.

Methyl cellulose: (cellulose methyl ether), corresponding to the 3 OH groups existing in the cellulose molecule per glucose unit, the etherification using methoxy groups CH_3O can lead to mono-, di- and trimethyl celluloses.

Methyl orange: (golden orange, helianthine, orange III, orange IV D), cationic orange dye; extremely sensitive to acid. Sodium salt of p-dimethyl amino azobenzene-p sulphonic acids. Soluble in water, insoluble in alcohol. Application: methyl orange test (change in colour at pH 4).

Methyl orange test: Methyl orange test is used (with 0.1 g to 100 ml of water) dissolved as an indicator. Reaction to alkali pale yellow; to mineral acid traces rose coloured. Neutralisation point: orange. Change to red/yellow at pH 3.1–4.4.

Methyl red: Cationic red dye, p-dimethyl-aminoazobenzene-o-carboxylic acid. Soluble in alcohol and acetic acid, almost insoluble in water. Used as an indicator (0.5% alcoholic solution) in the titration of weak bases. Yellow in alkali solution, red in acid solution (change in colour at pH 4.2–6.3).

Methyl violet: Cationic violet dye. Mixture of salts containing hydrochloric acid from tetra, penta and hexamethylpararosaniline. Soluble in water; sensitive to acid. Used as cationic dye for dyeing and printing. Dye for inks, ink pads, typewriter ribbons, photocopy paper, etc. As an indicator (Methyl violet test).

Methyl violet test: Indicator for traces of acids, which results in violet/greenish yellow change of colour occurs in the pH range 3.2–0.1. pH 3 violet; pH 2 blue; pH 1 green; pH 0 yellow.

Methylcellulose test on textiles: Solution of 0.5 g of benzamide indigo blue RRLS to 1 l of distilled water. Load fabric sample, treat for 3 mins, rinse, perhaps dry. Methylcellulose contents are (on every fibre material) immediately dyed dark blue, which is clearly visible under a magnifying glass, but most certainly microscopically. Starch is stained to an extent by this, but not cellulose glycolate.

Methyl dye: Blue and violet cationic dyes.

Methylene blue method: is used for the control and determination of the concentration of cleaning boosters in organic solvents in dry-cleaning. a certain quantity of solution from a cationic substance is added to a mixture of several ml of liquor with anionic dry-cleaning detergents, chloroform and an aqueous acid solution of methylene blue. Two layers are obtained Test method: an upper one containing water with a methylene blue colour and a lower chloroform layer, which should have the same blue colour as the upper

layer at the end of the reaction. Pure chloroform, indicator solution (sulphuric acid solution of methylene blue) and titration solution (approx. 1% solution of cetyl pyridinium chloride) are required for titration. Depending on the concentration of dry-cleaning detergent in the liquor, e.g. 5 ml of liquor is added (at 0.5–1% dry-cleaning detergent content) or 1–2 ml (at 2–4% dry-cleaning detergent content).

Methylene blue number: Characterizes the content of the carboxyl groups in damaged cellulose (oxycellulose). Wash out sample in diluted methylene blue solution and determine the dye uptake using colorimetry of the dye bath before and after washing out. More accurate, but more awkward is the Reversible methylene blue method.

Methylene blue test: For the testing of: (a) Oxy- and photocellulose. Wash out using methylene blue (cationic dye), rinsing with hot water. With damaged material, a lasting blue dye occurs (not however to undamaged cellulose). (b) Acid, alkali and mechanically damaged wool. This has improved dye affinity (test by counting the darker and brighter fibres under a microscope). (c) Linen compared with cotton: after washing out and thorough washing, linen remains permanently dyed, cotton does not.

Methylated DMDHEU: Modifying DMDHEU has been the most successful approach for reducing HCHO release. Among the first modified versions were those made from purer starting materials and rigidly controlling the stoichiometry. Later versions led to alkylated DMDHEU and two types have become commercially important products, methylated and glycolated DMDHEU.

Methylene blue testing: See **Methylene blue test**.

Methylolacryamide: This chemical contains an N-methylol group and acrylamide group, toxic. Used, amongst other things, as resin finishing agents in the so-called ambivalent crosslinking, usually together with cyclic N-methylol compounds. Finishings with moderate dry, but outstanding wet creasing angles, soft, smooth fabric handle. After-washing required.

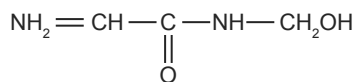

Methylol melamines: Melamine-formaldehyde compounds. Aqueous solutions of methylol melamines, less stable under storage conditions, self-polymerization in storage, therefore usually in powder form; only a few resin finishing products on a methylol melamine base.

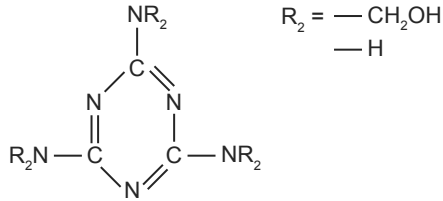

Methylol ureas: See **Urea-formaldehyde compound**.

Methylation: Introduction of *Methylol* group, e.g. conversion of NH-group containing compounds with formaldehyde to N-methylol compounds.

Metier: A spinning machine for producing manufactured fibres. The bank of cells or compartments and associated equipment used in the dry spinning of fibres, such as cellulose acetate and cellulose triacetate.

Metier twist: The amount of twist present in yarn wound at the metier.

Metre: (m) Unit of length; defined as the distance, through which the light in a vacuum passes during an interval of $1/299792458$ of a second.

Metric count: An indirect yarn numbering system for silver roving, and yarn, equal to the number of 1000m per kilogram.

Metric number: (metric count, Nm), a mass-related length for the Linear density of textile fibres and yarns. The designation Nm is permitted under the new law of units of measurement, as it derived from SI basic units such as mass and length. A larger Nm corresponds to a finer yarn. As this system is however contrary to the Tex system (a large number indicates a thick yarn) and by using the designation Nm a risk of confusion exists with Nm = Newton metres, the metric number should not be used any more as an indication of yarn fineness.

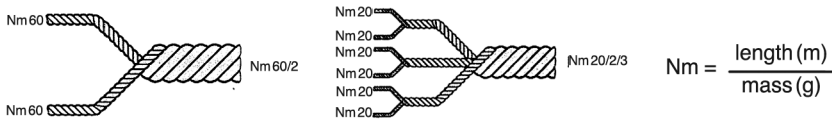

Metric system: In general terms, a system that is internationally consistent, and is based on units that are related to others by powers of ten (for example, a millilitre is $1/1000$ of a litre) The international consistency of this system and the general ease of calculations makes it vastly superior to systems with pounds and quarts and feet, etc., which define different quantities in different countries. Also see **SI**.

Mexicaine: French silk dress goods and ribbon made with narrow stripes and small figures on a taffeta foundation.

Mexican Embroidery: Made with ingrain cotton, silk or wool on muslin, cambric or linen; used for dresses, towels, etc. Usually only outlines of the patterns are embroidered.

Mexicans: A variety of gray English cotton goods, made for export; spun with well sized, coarse warp and medium fine filling, containing about 72 threads each way.

Meyers: Texas Commercial variety of prolific upland cotton, the staple measuring 30-95 millimeters; the yield is 31 per cent. Also called Maxey.

Mezzetta: Raw silk from Sicily.

MH: Abbrev. for Mohs' hardness scale, Hardness scale.

Micellar bundle: Bundled micelles, which consist of so-called fibrils, for example in Wool structure. One talks of : Micelles; Crystallites; Individual fibrils. of so-called fibrils, for example in Wool structure. One talks of : Micelles; Crystallites; Individual fibrils.

Micelle: When a surfactant is dissolved in water it forms a more or less ordered agglomerates of molecules called micelles. Pure water has a surface tension of about 72×10^{-3} N/m. As the surfactant is dissolved in the water the surface tension of water falls down rapidly, till it reaches a point called critical micelle concentration (CMC) where the surface tension levels off. At this point the surfactant molecules begin to orient themselves into clusters in the solution, the clusters being more or less lamellar or spherical.

Micellar chain: Designation in crystalline cotton structure for: Micelle; Crystallites.

Micelle starches: Starches reduced in their micellar size by steam, pressure, heating or mechanical measures. Particularly well suited to sizing purposes; therefore important for size boiling.

Miroil: French for the gloss given the fabrics in the finish.

Microaerophils: They are group of microorganisms that grow best in the presence of low concentration of oxygen.

Microcrystalline waxes: are higher melting (150°F), have higher melt viscosity and are soft microcrystals obtained by subjecting the wax distillation residue to a solvent crystallization process. The residue is dissolved in a mixture of benzene a methyl ethyl ketone and then allowed to crystallize.

Microbial damage to textile: The damage of fibres and fabric caused by bacteria, mildew and other microbes. It is generally promoted by a high moisture content, relatively high temperature, individual optimum pH (for bacteria pH 7–8.5; for fungi pH 4.5–7.5) and especially in a contaminated state. Cellulose materials are attacked by earth bacilli, fungus, moulds, bacteria especially at higher humidity and temperature of the range 25–35°C (tropical climate). Wool is also damaged by earth bacilli, pathogenic type bacteria and fungus. Since wool are having comparatively higher moisture regain power these type of damage is more frequent. Synthetic materials are more or less unaffected by bacteria.

Microbial growth curve: A graph showing the rate of growth of a particular species of micro-organism for a specific food input. It is not necessarily accurate to use this growth curve to describe population growth in complex microbial systems such as **Activated sludge**. See **Growth phases of microbes**.

Microdenier: Refers to fibres having less than 1 denier per filament or 0.1 tex per filament.

Microdisperse: One commercial form of vat and disperse dyes marketed. These forms will have particle size of 0.2 to a max. 1 mm. and made into fine dispersions for the ease of application.

Microemulsions: Microemulsions are the ones with smaller particle than normal emulsions. Normal emulsion are of particle size of > 300 nm. They are normally white in colour. Microemulsions are the ones with particle size 100 – 10 nm. They are bluish in colour and less than 10 um are as clear as water.

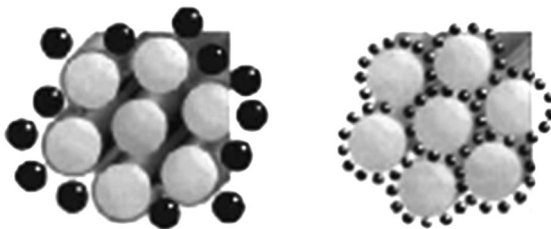

Macro emulsion Microemulsion

Microencapsulation: Enclosing materials in capsules of less than one micron to over 2000 microns in diameter. These can contain polymer additives that can then be released under certain conditions of use or processing.

Micro-encapsulation: It is a designation for the encapsulation of finely dispersed, fluid or solid phases by coating with film-forming polymers.

Microfibres: The usual definition of a microfibre is one that has a count of less than 1.0 denier or decitex. A typical PET yarn might contain 30–50 filaments, each with a denier in the range 2.0–3.0. A microfibre yarn may have well over a hundred filaments of 0.5 denier.

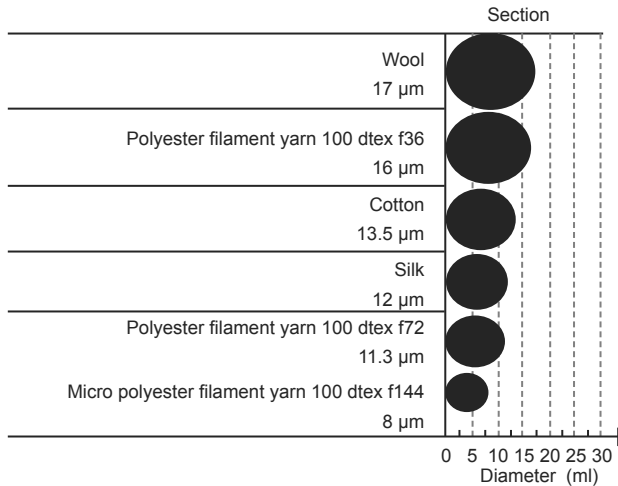

Sizes of different fibres

Microfibre batting: A textile filling material containing fibres, such as polyester or olefin, which have a diameter of less than 10µm.

Microfiltration, in ETP: Filtering water through a cartridge of pore size 0.1–0.5 µm that can remove particles down to the range of 0.05 to 0.5 µm like TSS, turbidity, protozoan oocysts, some bacteria and viruses. The operating pressure is 2–7 bar. The micro-filter membrane requires periodic backwashing. Microfiltration can filter out micro-organisms and it is useful for the removal of *Giardia* and *Cryptosporidium* from water and the process is used in a number of large scale water treatment plants. It has also been used for the removal of micro-organisms from wastewater effluents.

Micronaire value: A dimensionless number characterizing the fineness of cotton fibre. The value is defined on the Sheffield 60 600 micronaire device (standard device). All different devices must be calibrated to it. The micronaire value scale ranges from 2.3–8.0 corresponding air stream of 9.9 to 60.6 l/min).

Micronaire method: A means of measuring fibre fineness by determining the resistance of a sample to a flow of air forced through it.

Micronire reading: A relative measurement of fibre fineness derived from the porous plug air-flow method.

Micro-organism, microbe: Microscopic organisms that include actinomycetes, algae, bacteria, cyanobacteria, protozoa and some fungi.

Micropore finishing: In this method of finishing coated fabric is made porous for air and sweat to pass through where as heavy rain is kept out. The method is to lay about 0.7mm thick finishing layer on the fabric and the bombarded with electron beam on to the fabric surface to produce 1 million pores per square metre. Polyacrylate, polybutadiene, polyurethane and certain polyvinyl chloride coatings and laminates are particularly suitable. Already manufactured textile materials are not suitable for this process.

Microporous coating: Coatings with breathable properties. The coated fabric will transmit vapors at the same time it will be water proof. Such coatings are produced when coating drying is condensed by the use of calenders and re-waterproofed or given a finishing lacquer . This is absolutely essential, as the pores are somewhat larger than those of the remaining poromers (15–50 mm) and therefore have relatively poor water impermeability. The number of pores is approx. 500 000 per cm². Another process is by products manufactured by “coagulation” (precipitation, clotting) are distinguished by special softness and textile characteristics, unlike any other coating processes. These coatings can be further provided with a closed top film, which increases water impermeability. This top film thereby prevents the contamination of the coating from soiling and pore clogging.

Microtubules, in cotton: Cellulose microfibril orientation angle is an important factor in fibre strength. The orientation of cellulose microfibrils in the cotton fibre secondary cell wall is regulated by the orientation of structures in the cytoplasm collectively called the cytoskeleton. Principal components of the cytoskeleton are the filamentous structures known as microtubules and microfilaments. Microtubules are composed of two proteins, *a*- and *b*-tubulins, and microfilaments are composed of the protein, actin.

Microwave drying: The application of microwaves and high frequencies in fabric drying. The heat transfer in the fabric, from the surface toward the inner part, takes place with a certain difficulty due to the poor thermal conductivity of the fabric with subsequent problems to obtain a temperature uniformity in the whole heated mass, in relatively short times. By means of radio frequency waves, heat develops inside the material in a quantity that is proportional to the water dispersed in it. Radio frequency: 13.56 and 27.12 MHz. Microwaves: 915 and 2,450 MHz. Usually high frequency is applied to very thick fabrics (hanks, packages, bales) or to produce fast binding of latex layers, while microwaves are used for high-speed thermal treatments of yarns and fabrics. A drying unit includes the following elements: a) generator; b) electrodes; c) drying compartment.

Microwave moisture measurement and controls: Microwave technology is used for measuring the moisture content on fabric at various stages like padder (to measure the expression after padding and variation across the width), stenter to control the moisture at the exit of the stenter and there by the speed control of the stenter. The principle is to pass a defined microwave emission beam onto the damp fabric and the proportion of microwaves not absorbed because of its density is measured and related to the humidity by calibration.

Microwax: Used for water proof finishes. They are hydrocarbon wax made from de-paraffined products (paraffin gatch, petroleum gatch, etc.), obtained after de-oiling/cleaning. Colour black/brown/yellow/white; consistency sticky, soft malleable to hard. Has higher setting range/melting point of 55–90°C compared with commercial paraffins and a very fine crystal structure.

Midani Silk: Warp faced fabric with cotton filling, having narrow colored stripes divided by narrow white stripes.

Mid-neck girth, in body measurements: The circumference of the neck approximately 25 mm (1 in.) above the neck base.

Mid-thigh girth, in body measurements: The circumference of the upper leg between the hip and the knee.

Mi-fils: The finest and thinnest French cambric.

Mi-florence: Light, plain spun silk lining, finished with a high gloss.

Mi-torse: Half twisted French embroidery silk.

Mignardise: Crochet work using narrow braid to form the body of the pattern.

Mignonette[?]: A knitted silk or viscose fabric used for underwear. It is finer than tricot.

Mignonette: (1) Plain cotton netting; used for curtains; (2) French calico with small pattern.

Mignonette Lace: Narrow bobbin lace of lightweight made in the 16th century and 17th century of white flax thread; used for headdress. The mignonette pattern is very small and delicate.

Migration: The movement of an added substance, e.g. a dye or an alkali, from one part of a textile material to another.

Migration: (1) Movement of dye from one area of dyed fabric to another. Includes movement of colour from the dyed area to the undyed area of cloth. This is usually a property of the dye and greatly depends on the molecular size. (2) Movement of fibres which go from the center to the outside surface of yarn and back again periodically. (3) Migration power of a substance in or on the substrate from places of higher to places of lower concentration.

Migration in intermediate drying: This happens due to too little substantivity of the dyes under drying conditions and also to high moisture absorption. Migration tendency is greater in polyester/cellulose blend fabrics than in cotton and is encouraged by uneven drying. The smaller the particles of the dye the stronger the migration during drying. The coarser the yarn or the more densely beaten the fabric, the stronger the migration effect. Recommendations for avoidance: as little liquor pick-up as possible during padding. Resting of the damp fabric after padding or drying. Effective drying evenly across the whole width of the cloth. Avoid shock drying. Use products, which cause a change in the particle size under drying conditions. Only use wetting agents as far as necessary.

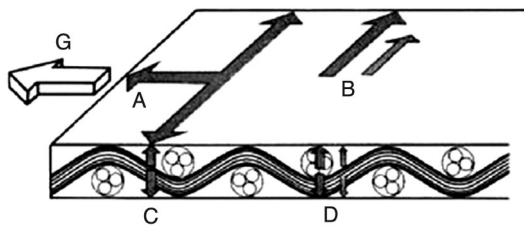

Diagram showing the migration types during pad-dry processes

Migration propensity of dyes: Capacity for Migration, in order to even out concentration differences. The levelling capacity of dyes is not only dependent on dye properties, but also on the textile material and dyeing process. The migration propensity of dyes is jointly responsible for their Levelling behaviour. (Dye migration in drying).

Migration inhibitors Substances: Which are added to the pad liquor in order to prevent the migration of dyes when drying. The alkaline saponification of polyacrylonitrile facilitates the manufacture of water-soluble products, which can be used as migration inhibitors in the thermosol dyeing process.

Migration test: (1) Sandwich test: three fabric sections of 15 x 30 cm are padded and then closely fastened on top of each other on a pin frame. This is then dried in a hot air flow under precisely defined conditions. It is fixed, reductively cleaned or boiled with soap depending on the dye classification. The outside of the fabric (1, top or bottom), the middle fabric layer (2) as well as the inside of the fabric (3, top or bottom) are assessed. (2) Hair-dryer test: a padded fabric is laid onto a wire grid and dried from above using a hot air hair-dryer at a distance of 20 cm. The front and back of the fabric section are assessed with regard to difference in depth of colour or shade of colour after drying. (3) Crease test ("concertina test"): a fabric strip 75 cm long and

6 cm wide is padded and folded in book form. The small fabric staple length is dried between two glass plates in the drying cabinet at a given temperature.

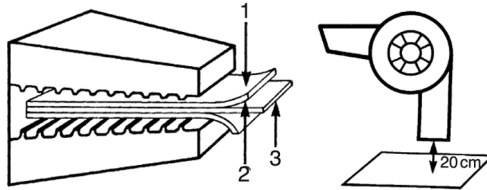

Sandwich test for migration Hair-drier test for migration

Mikado: A fine and light all-silk taffeta.

Mil: A unit of length, 0.001 inch, commonly used for measuring the diameter of wires and textile monofilaments.

Milan braid: A corded flat mohair braid; used for trimming.

Milan point: A needle point tape lace with a picot edge. Once hand made, but the simplicity of the design easy to imitate by the machine. Originally plaited gold and silver lace and reticella. Later fine needle-point laces, made with scroll designs, large flat flowers in cloth stitch. At the present a machine made lace, the design outlined with silk.

Milanaise: Narrow braid or corded fabric in which the cord effect is produced by leno weaving. One end is made to cross a number of ends in an alternate crossed and open shade sequence.

Milas rugs: One of the finest and most beautiful Anatolian Prayer mats. Smoother, rather shorter pile with approx. 150 000 knots per m². Colourful, bright colours. Varied patterning varying from small flat stylized flowers to geometric shapes.

Milanese: A low quality cotton fabric of about 17 × 14 tex with approximately 30 ends × 28 picks per cm.

Milanese knitting: See **Knitting**. Knitted fabric with very fine gauge, with almost equal elasticity both ways. It is a warp knitted fabric made with flat bearded needles and thread laying attachment; used for underwear.

Milanese Lace: An embroidered drawn work, made of abaca by the natives of the Philippine Islands.

Milassa: Hand knotted all-wool rugs of Asia Minor; the pile is tied in Ghiordes knot. They come either in striped design or in prayer rug patterns, with old gold as leading colour.

Mildew: A whitish growth caused by spore-forming fungi that grow in a warm, moist, confined atmosphere. The formation of mildew may cause discoloration, tendering, or variation in dyeing properties in cellulosic fibre.

Mildew resistance: The degree to which fabrics are unaffected by certain fungi that cause odor and discoloration.

Mildew-resisting agent: See **Fungicidal finishes; Antimicrobial finishes.**

Military Braid: Flat, coarse ribbed worsted, braid; used for trimming uniforms.

Milium: The trade name for a fabric which is insulkated by applying aluminium flakes to its back. The fibre of the fabric may be cotton, acetate, viscose, nylon, polyester. The insulation keeps out the cold in winter nad heat in summer. It was once a common coat lining, now mainly used for certain lining.

Milk of lime: Calcium oxide.

Mill end: A remnant or short length of finished fabric, like remnants, seconds, short ends of fabrics spun at the mills.

Mill engraving: After producing the master pattern die (Pattern die) the actual mill engraving is carried out on the engraving mill (engraving machine). The hardened relief engraving is thereby pressed against a rotating copper printing roller with a thrust up to 7 tonnes until the required engraving depth has been reached. Mill engraving is precision work, as the repeats in height and width must turn into each other without any transition.

Mill grain, in grain: Grain which is imparted to rubber sheeting while being mixed or conditioned in a rubber mill and which is parallel to the direction the rubber moves in the mill.

Mill run: A yarn, fabric, or other textile product that has not been inspected or that does not come up to the standard quality.

Mill wrinkle: See **Crease.**

Mille fleurs: All over pattern of small flowers. Used in dresses and blouses.



Mille Point: (1) Twilled English woollen, of high finish, with small patterns. (2) Tiny allover dot pattern.

Mille Raye: Originally a percale with many narrow black and white stripes; also a modern cotton and silk dress goods with numerous, very narrow stripes.

Milled composite fabrics: Bonded fabrics made from e.g. nonwoven wool (blends) bonded using felting and milling.

Milli- Symbol: m A prefix denoting 10^{-3} . For example, 1 millimeter (mm) = 10^{-3} meter (m).

Milligram, mg: One thousandth of a gram; 1mg, 1000 micrograms, 10^{-3} gram.

Milligram equivalent per litre, milliequivalent per litre, meq/litre: A way of expressing the concentrations of substances in water instead of using mg/l. The concentration in mg/l is divided by the equivalent weight. A solution with a strength of 1 meq/l has one-thousandth of the strength of a normal solution.

Millimole per litre, mmol/litre: The concentration in mg/l divided by the gram molecular weight of the substance. A solution with a strength of 1 millimole/l has one thousandth of the strength of a molar solution.

Milliners needle: These hand sewing needles are long, narrow needles with a small round eye. They are used in Baltimore Applique, as well as sewing beads and French knots. They range in size from 3 to 9.

Milling: (1) The process of treating fabric in a fulling mill, i.e., fulling. (2) In silk manufacturing the twisting of the filaments into yarn. (3) A grinding process, i.e., ball-milling of dyes and pigments.

Milling auxiliaries: (milling soaps) are used for the support of felt formation (thread end) in the milling of wool. This mostly concerns surfactants or preparations based on them.

Milling dye: a class of acid dye There is no clear distinction between milling acid dyes and super milling acid dyes. They come in a range of colors, including some bright shades and a large choice of "pure" (as opposed to mixtures) colors. Wash fastness is generally quite good. Light fastness varies from poor to very good. Retarders are usually used to help achieve level results. Application temperature is typically at or near the boil. These dyes are used on wool and polyamide (nylon). The term "milling" is said to refer to a process of making wool felt; milling dyes don't wash out badly in the process.

Milling process: Matting and condensing (increased shrinkage in length and width) of wool piece goods (possibly also with a proportion of extraneous fibres) in the hot damp state, preferably of more open carded yarns. Milling is carried out in acid (See **Acid milling**) and/or alkaline liquor.

Milling shrinkage testing: (1) Mark in a metre on grey goods in the sealing department.

After milling, the difference between raw and finished length produces the felting shrinkage (in %, referring to the raw length). (2) Subtract percentage finishing loss (difference between raw and finished fabric weight) from the raw weight; divide the difference by the current finished weight per metre.

Milling Theory: It is also called felting theory. Milling is a process of fibres getting tangled and formation of a homogeneous top layer from loose fibres by use of friction, impact or pressure in the presence of heat and moisture. The main reason of felting is the scaly surface of the wool fibre.

Millimeter of mercury: See **mmHg**.

Millitron[®] process: Computer-controlled carpet spray printing, whereby dye solution is sprayed into the carpet pile from nozzles. As it is processed without screens, there is no contact with the carpet surface, therefore no deformation of the pile material and, when changing patterns, no machine stoppage.

Millon's reagent: Used for following tests. (1) For the testing of protein substances (finishing analysis); reagent easily decomposable; always prepare freshly before use (consisting of 20 g of mercury and 40 g of nitric acid, heat in water bath until dissolved, leave for 24 hours, pour off precipitate; with protein, is turbid until precipitation, pink hue during heating); optimum pH range for reaction: neutral to weak acid. (2) For the testing of wool damage, i.e. degraded wool (reaction to the amino acid tyrosine). Boil sample with solution of mercury nitrate in nitric acid. This initially results in a white precipitate, which is then dyed reddish-brown (violet). 3. Testing of animal fibres (silk, animal hair fibres, casein) besides man-made fibres. It results in a red to reddish-brown hue when heated (animal fibres).

Milnerised process: Finishing process using application of resin finishing agents, catalysts and additives together with sizing agents and dyes on warp yarns made from polyester/cotton.

Miltons: Thick and well fulled woollen suiting; used for hunting garments in England; came usually in brown, red and blue colours.

mmHg: (millimeter of mercury) A former unit of pressure defined as the pressure that will support a column of mercury one millimeter high under specified conditions. It is equal to 133.322 4 Pa, and is almost identical to the torr.

Mina cloth: Stout twilled cloth of wool and cotton.

Mineral dyes: Inorganic coloured pigments known as so-called paints. Hardly used for textile dyeing and printing any more. The Mineral khaki formed on the fibre is of some interest.

Mineral fibres: A generic term for all non-metallic, inorganic fibres, which may be natural, such as asbestos, or manufactured from such sources as rock, ore, alloys, slag, or glass.

Mineral khaki: An excellent mineral dye produced on the fabric. Method: Using blends of soluble chromium salts (higher quantity used results in greenish tone) and iron salts (higher quantity used results in brownish khaki). Process:

- (a) Impregnate on the 3 milling padder with the above blend (density 1.18).
- (b) Short steaming or drying (hotflue).
- (c) Passage through a) a bath (density 1.06) of 1 part caustic soda liquor 40°Bé and 3 parts sodium carbonate calc. (formation of chromium oxide and iron oxide on the fibre) or b) weak sodium carbonate solution and then diluted hypochlorite solution. Alternatively it is slowly heated to 80°C on the jigger using iron (II) sulphate and chromium salt; then follows rinsing, soaping, cold and hot final rinsing.

Mineral silicate Fibres: Belonging to the group of mineral fibres; industrially manufactured fibres made from the melting of rocks. Only for industrial purposes.

Mineral weighting: Weighting of silk using inorganic salts (tin-phosphate-silicate weighting).

Mineralization: Introduction of metal ion.

Minimum Care: A term describing home laundering methods. A care label used for fabrics which can be washed satisfactorily by a normal home laundering and used or worn after light ironing. Minimum care fabrics, garments, and household textile articles can be washed satisfactorily by normal home laundering methods and can be used or worn after light ironing. Light ironing denotes ironing without starching or dampening and with a relatively small expenditure of physical effort.

Mink: A very distinctive long pale brown fur from an animal which can be ranch bred or wild. There are also Chinese Mink or Kolinsk Mink, which is of unusual colourings, e.g. silvery blue and black. Mink is luxurious, but it is also hard wearing. It is often used for hats.

Minor defect: A defect that is not likely to materially reduce the usability of the product from its intended purpose or is departure from established standards having little bearing on the effective use of operation of a product.

Minor imperfections, in fabric grading: A deviation in a roll of fabric that judgement and experience indicate is likely to have no bearing on subsequent processing of the fabric.

Miralene: Polyester fibre, crinkle or boucle type yarn based on Terylene.

Miralon: A process applied on nylon yarn for bulking the yarn. The bulking makes the fibre warmer, as air is introduced, and also softer to the feel.

Mirror velvet: Velvet produced in the normal way, but with a pattern made by pressing the pile flat in different directions and giving a shimmery or mirror effect.

Mirecourt Lace: Originally a French bobbin lace, similar to Lille (see), lately bobbin made sprigs are applied on -machine net ground.

Misclip: See **scalloped selvedge**.

Misdraw: See **Wrong draw**.

Mis-Knit, in knitted fabric: A deviation from the designated knitting pattern.

Mispick, in spun fabrics: A pick not properly interlaced which causes a break in the weave pattern. See also **Double pick, Wrong draw**.

Misprint, in printed fabrics: Colours or patterns, or both, either missed, or partially missed, or incorrectly positioned relative to each other.

Misregister, in printed fabrics: Colours or patterns not correctly positioned (compare Misprint).

Missing end: See **End out**.

Missing pick: See **Broken pick**.

Missing thread: A thread or pieces of ground or effect threads which are missing in the fabric weave.

Miss pinning fault: (stenter miss clipping). Appearance of fault on fabrics due to occasional non-gripping of the fabric edges on the part of the clips on the stenter.

Miss-stitch: A knitting construction formed when the needle holds the old loop and does not receive new yarn. It connects two loops of the same course that are not in adjacent wales. Also known as float-stitch.

Mistral: This is a crepe effect worsted cloth. Twisted warp and weft yarns are used.

Mitafi: Variety of Egyptian cotton, having a fine, long, strong staple of dark brown colour; extensively cultivated.

Mitcheline Quilt: A double cloth, spun with two sets of warp and two sets of filling, the figures formed by interchanging the two fabrics. The two fabrics are united together throughout the entire structure.

Miter: is a diagonal seaming at a corner. This is done at the corners of quilt borders to make them look like the corner of a picture frame.

Mitkal: Narrow cheesecloth or cotton sheeting, gray or bleached, made in Russia.

Miwata: Japanese trade name for unginned cotton.

Mixed Checks: English striped or checked fabric, the white stripes being of linen and the colour of cotton.

Mixed end, in spun fabric: A warp yarn differing from that normally being used in the fabric.

Mixed filling: Filling yarn differing from that normally used in the fabric, e.g., yarn with the incorrect twist or number of plies, yarn of the wrong colour, or yarn from the wrong lot.

Mixed Fabrics: Contain more than one kind of fibre.

Mixed filling, in spun fabric: A weft yarn differing from that normally being used in the fabric.

Mixing: The blending of several varieties and grades of cotton or wool to obtain a uniform average as to colour, strength and length of the fibres.

Mixture: (1) Yarn which is spun of fibres in more than one colour but each kind of 'fibre being only of one colour. (2) Fabric spun of such yarn.

Mixture Crepe: Made of silk warp and hard spun cotton filling; used for dresses, waists, etc.

ML, megalitre One million litres, 1000 m³, 1000 t of water.

MLC: (1) Minimum lethal concentration. *See* **Minimum lethal dose**. (2) Median lethal dose. *See* **LD50**.

MLE process: Modified Ludzack-Ettinger process.

Mld: Megalitres per day, i.e. 1000 m³/d.

MLD: Shortened form of minimum lethal dose (lethal limit), i.e. smallest known lethal basis for humans. In inhalation poisons, the criticality limit for gases, vapours and volatile suspended matter is usually given in ppm (cm³ gas/m³ air), for non-volatile suspended matter (dust, smoke, aerosol, etc.) in mg matter/m³ air.

MLR: Material Liquor Ratio. It is most important feature of the dyeing machines. If 100 kg of fabric is dyed in a bath of 1000l dye liquor its MLR is

said to be 1:10. Now a days it is of utmost important because of the limitation of effluent discharges and controls. It is always preferred a machine with lowest possible liquor ratio without affecting the quality of dyeing. Lower liquor ratio means less chemicals, dyes, salt, steam water and energy, less load of waste water, thus overall reducing the dyeing cost. In exhaust dyeing many machines have been developed to reduce MLR, airflow dyeing is one of the most successful of them. In yarn dyeing the air pad method is used to reduce the MLR when dyed with partial loading.

MLSS, mixed liquor suspended solids: The dry suspended solids in mixed liquor (mg/l). Conventional activated sludge plants operate at 2000 to 3500 mg/l but oxygen activated sludge plants may operate at 6000 to 8000 mg/l. See also return activated sludge.

MLSS: Mixed liquor suspended solids The dry suspended solids in *mixed liquor* (mg/l). Conventional *activated sludge* plants operate at 2000 to 3500 mg/l but *oxygen activated sludge* plants may operate at 6000 to 8000 mg/l. See also **return activated sludge**.

MLVSS: Mixed liquor volatile suspended solids The dry volatile *suspended solids* in mg/l of *mixed liquor*. MLVSS is often considered to be about 70% of the *MLSS* and may be used in preference to *MLSS*.

MME: Mechanised metal extraction.

Mo: Mohair.

Mobile creel: See **Creel, Mobile**.

Mocado: The mock velvet of the 16th and 17th centuries; not now made.

Mocha leather: Fine, soft sheepskin leather from Africa and the Middle East. If available, it is easy to sew.

Mock dyeing: A heat stabilization process for yarns. The yarns are wound onto packages and subjected to package dyeing conditions (water, pressure, temperature) but without dye an chemicals in the bath.

Mock flat-felled seam: See **Double welt seam**.

Mock french seam: A complex seam formed on the inside of the object with raw edges enclosed and no stitching rows visible on the face side; similar in appearance to the french seam but constructed differently.

Mock leno: A fabric having weave with a combination of weaves having interlacings that tend to form the warp ends into groups (with empty spaces

intervening) in the cloth, thereby giving an imitation of the open structure that is characteristic of leno fabrics. Mock leno fabrics are used for summer shirts, dresses, and other apparel, and as a shading medium in Jacquard designs. See **Mock-leno weave**.

Mock leno weave: A weave in which the warp yarns remain parallel but form open warp stripes by programmed interlacing of warp and filling yarn simulating a leno appearance. A weave that has open spaces between groups of warp yarns and between groups of weft yarns and a similar appearance to that of a leno weave (q.v.).

Mock-space loom: A multitier loom in which all pieces being spun in any one row are so spaced as to lie immediately above or below the landing of those in a vertically adjacent row.

Mock Satin: Strong, stiff weft faced wool satin with flower patterns spun into.

Mock Twist: A fancy single yarn; used for dress goods, similar to the double and twist (see) but the two colors are not outlined as sharply and regularly. It is produced by intermittent feeding of dyed and undyed stock in the spinning frame.

Mock voile: A plain weave cotton fabric spun from hard twisted single yarns, (instead of two fold) spun with one thread per dent.

Mockado or Mokario: Fabrics used for clothing in the 16th and 17th centuries in England. (a) one was a woollen fabric, often mixed with silk, heavily napped and spun with figures; (b) another solid colored napped woollen fabric was also called mock velvet.

Modacrylic fibre: A manufactured fibre in which the fibre forming substance is any long chain synthetic polymer compound of less than 85 % but at least 35 % by weight of acrylonitrile units ($-\text{CH}_2-\text{CHCN}-$) Although modacrylics are similar to acrylics in properties and application, certain important differences exist. Modacrylics have superior resistance to chemicals and combustion, but they are more heat sensitive (lower safe ironing temperature) and have a higher specific gravity (less cover). The principal applications of modacrylic fibres are in pile fabrics, flame-retardant garments, draperies, and carpets.

Modal fibres: (abbrev.: CMD, MD), regenerated Cellulosic fibres with a high resistance and high wet modulus, manufactured by the addition of modifiers and by variable spinning speeds (wet elongation 15% at 2.25 cN/dtex load). This includes both Polynosic fibres and High wet modulus fibres. Modal fibres have a higher degree of polymerisation (DP 350–600), higher resistance, wet modulus, dimensional stability and alkaline resistance compared with normal viscose fibres. HWM fibres have lower alkaline resistance and lower

brittleness compared with polynosic fibres.

Mode: The value of the variate for which the relative frequency in a series of observations reaches a local maximum.

Modena: Light weight dress goods from Italy, made of mixture of silk waste, cotton and wool.

Moderne: Thin French cloth made of mixture of waste silk with cotton or wool.

Modes: In bobbin and needle-point laces various stitches which fill out the patterns. Also called fillings, jours and lead work.

Modesty piece: Decorated, triangular insert for the neckline of a bodice.

Modica: Raw silk from Sicily.

Modified biochemical oxygen demand test: (BODT, so-called closed bottle test), in which is indicated the measurability of the Biochemical oxygen demand (BOD) utilised in the microbial oxidation of organic substances and the % measuring result of the theoretically necessary calculable oxygen demand for final oxidation, i.e. mineralisation of the test substances (% BODT). With this method, the BOD5 value comes to hand incidentally as it were.

Modified DMDHEU: Modifying DMDHEU has been the most successful approach for reducing HCHO release. Among the first modified versions were those made from purer starting materials and rigidly controlling the stoichiometry. Later versions led to alkylated DMDHEU and two types have become commercially important products, methylated and glycolated DMDHEU.

Modified fibres: Viscose, high tenacity and high wet tenacity fibres with a particular structure caused by spinning in the presence of Modifier (small additions of aliphatic amines, polyamines, quaternary ammonium compounds, polymers of ethylene and propylene oxide amongst others). These altered spinning conditions produce new valuable properties with suitable draw stretching: higher strength, higher working capacity, denser, homogeneous cross-sectional structure (all enveloping structure), lower swelling power and better wet tear strength.

Modified grab test, in fabric testing: A tensile test in which the control part of the width of the specimen is gripped in the clamps and in which lateral slits are made midlength of the specimen serving all yarns bordering that portion of the specimen held between the two clamps.

Modified starch: The working properties of starch solutions (viscosity, retrograding point, penetration into yarns etc.) are influenced by the source of starch. The reader is referred to any of a number of well written books and reviews extolling the virtues of the various natural starches. In addition to naturally occurring variations, there are chemical modifications where some of the natural starch properties are altered to make them more useful.

Modified worsted system: A worsted system for spinning man-made fibres which relies on pin control of fibres during sliver weight reduction, but which bypasses the system of combing required with wool to remove noil.

Modifier: Modification agent, in Modified fibres these assume important structural modifying functions as spinning auxiliaries, which result in the slowing down of the conversion on the spinning bath/ thread surface and thereby encourage the formation of

all cover fibres with improved dry and wet properties.

Module, for inflatable restraints: An assembly composed of an inflator, a cushion, a mounting device, a trigger, and a cover.

Modulus: The property of a material representative to deformation. The ratio of change in stress to change in strain following the removal of crimp from the material being tested; i.e., the ratio of the stress expressed in either force per unit linear density or force per unit area of the original specimen, and the strain expressed as either a fraction of the original length or percentage elongation. Also see **Young's modulus**.

Modulus, Chord: See **Chord Modulus**.

Modulus, Initial: See **Initial modulus**. The slope of the initial straight portion of stress-strain curve (load elongation curve).

Modulus, Secant: See **Secant Modulus**. The ratio of change in stress to change in strain between two points in a stress strain curve.

Modulus, Tangent: See **Tangent modulus**. The ratio of change in stress to change in strain derived from the tangent to any point in a stress strain curve.

Modulus, Textile: See **Textile Modulus**. The ratio of change in strain in the initial straight line portion of the stress-strain curve following the removal of any curve.

Modulus, Young's: See **Young's Modulus**. For perfectly elastic materials: It is the ratio of change in stress to change in strain within the elastic limit of the material.

Mogador: Even though earlier this term was used for a silk fabric used for mens cravats, it is now used for an acetate fabric resembling faille. It is mainly used for mens ties.

Moghan carpets: Knotted carpets from the South-East Caucasus. Moghan Steppe. Medium high wool pile with approximately 150,000 knots/m². Coloured design with a lot of bright yellow in the bright variation of geometric flourishes, flower and animal motifs.

Mohair: The hair of the Angora goat, *Capra* species found in Turkey, South Africa and USA.

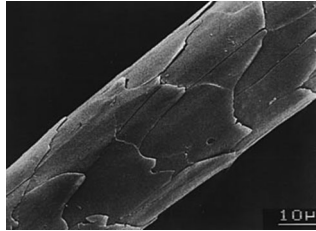

Magnified Mohair fibre

Unlike Sheep's wool this hair is not curly. It is dyeable and having a lustre and stronger than wool. It can be mixed with other yarn to make warm lightweight fabrics.

Mohair suiting: Mohair can be combined with worsted yarn, or spun alone, to produce a very lightweight, shiny, attractive suiting. Used for men's lightweight suits dinner jackets etc.

Mohair wool: Thick, spongy open fabric, in plain weave, with a very hairy texture. Its composition is usually 70% Mohair and 30% wool. It is very bulky and can be used for warm, lightweight lined coats, but is best for simple wrap-over jackets, sleeveless waistcoats, etc. which are unlined, and is excellent for shawls and stoles.

Mohr bleach: Combination bleach for cotton fabric in three stages:

- (a) Pre-boil grey fabric in (used) peroxide bleach liquor.
- (b) Chlorine bleach with sodium hypochlorite.
- (c) Peroxide bleach (used liquor is used for each following batch).

Mohwal: Bast fibre of the *Bauhinia vahlii* in India; used for ropes.

Moiré: A finish with a wavy, watermark effect that can be applied to a variety of fabrics of almost any fibre, but is most used on silk, acetate triacetate. The fabric is passed through engraved cylinders which press the water mark onto the fabric. The finish is not necessarily permanent.

Moire: The "watered" effect given in the finishing process to mostly silk but also cotton and wool fabric. This effect is produced in various ways; (1) see

Moire antique; (2) the fabric is passed between engraved cylinders which press the moire design into the face. This moire is not as lasting as the first one. Ribbed fabrics are better adapted for both these moire effects, although many smooth fabrics, like taffeta, are treated this way. (Besides these moire effect is produced by printing the fabric, the various colors overlapping each other; moire effects are also obtained by certain weaves.



Moire a Pois: Moire silk fabric, spun with small satin dots on the face.

Moire Anglaise: Same as Moire antique.

Moire Antique: A mechanical finish. To produce this finish the fabric is folded lengthwise with face in, the selvages covering each other and stitched together. The fabric is then dampened and passed between hot cylinders. This moire effect is lasting and shows the greatest variety of designs.

Moire' effect: Are produced by interference from two linear systems. Moiré interferometry processes, which are used for the testing of surfaces, offer extensive detection. These processes are based on the fact that the overlay of the transmission functions of two equal, easily bent together, optical gratings produce characteristic intensity patterns in the form of light/ dark stripes. In screen printing, moiré effects can in particular be put down to the fact that the thread system of the mesh and the fabric to be printed knit into each other. A certain screen angle of the combining linear systems can prevent the appearance of moiré. Moiré is produced in roller printing if very fine longitudinal stripes are printed on coarser fabric qualities. In order to avoid this, the fabric is calendared before printing. In decatizing, moiré is produced in the interaction of the weft threads of wool fabrics and cotton back grey (worn out).

Moire fabric: (from French: marmoire = marbled), most easily ribbed material (silk or viscose filament) with imprinted (lustrous) pattern effects, in plain, satin or twill weave, predominantly one colour. Antique moiré: with indefinite linear guidance, produced by pressing two material webs lying on top of each other. Renaissance moiré: with stronger "soaking". Application: for garment, furnishing, upholstery fabrics and similar.

Moire francaise: Moire made in stripes. Another variety called moire ronde.

Moire metallique: A frosted watered effect on silks.

Moire' tafetta: Taffeta weave fabric made from silk or synthetic fibres and then embossed with a moiré pattern. The embossing may be or may not be permanent depending on the fibre and processing.

Moirette: Plain spun cotton fabric, made of fine warp and thicker polished filling, finished in a moire effect by pressing.

'Moire' finish: Also called **Watered effect**. A wavy, rippled or watered appearance on a spun rib fabric and that is produced by the action of heat and heavy pressure from rollers.

NOTE: The appearance is caused by differences in the reflection of light by the flattened and the unflattened portions of the ribs, and there is no definite repeat in the pattern.

Moiring: Making moiré effect by any method.

Moist-cure process : Wet crosslinking process.

Moist-dwell process: Fixation of compounds (e.g. resin finishing agents) by dwelling of the fabric in a moist state. See **Wet cross-linking process; Cross-linking**.

Moisture, as used with textiles: Water absorbed, adsorbed or resorbed by a material.

Moisture: (moisture content). Humidity, being moist, light dampness, water (vapour) content.

Moisture as-is: Deprecated term. See **Moisture content**.

Moisture as-received: Deprecated term. See **Moisture content**.

Moisture content: (1) The amount of moisture in a material determined under prescribed conditions and expressed as a percentage of the mass of the moist material, that is, the original mass comprising the oven-dried substance plus any moisture present.

(2) That part of the total mass of a material that is absorbed or adsorbed water, compared to the total mass (compare Moisture pick up, Moisture regain).

Moisture content, at moisture equilibrium: The moisture content of a material in equilibrium with air of known, or specified, temperature and relative humidity.

Moisture equilibrium: The equilibrium reached by a particular material with the surrounding atmosphere with respect to moisture i.e. when it no longer takes up moisture from, or gives up moisture to, the surrounding atmosphere.

Moisture equilibrium, for preconditioning: The moisture condition reached by a material during free exposure to moving air in the standard atmosphere for preconditioning.

Moisture equilibrium, for testing: The condition reached by a sample or specimen during free exposure to moving air controlled at specified conditions.

Moisture equilibrium, for testing- for industrial yarns and tyre cords: The condition reached when, after free exposure to a test atmosphere which is in motion, two successive weighing not less than 4 h apart, show not more than 0.1% progressive change in mass of the specimen or sample.

Moisture free: The condition of a material that has been exposed in an atmosphere of desiccated air until there is no further significant change in mass.

Moisture free weight: (1) The constant weight of a specimen obtained by drying at a temperature of 105°C in a current of desiccated air. (2) The weight of a dry substance calculated from an independent determination of moisture content (e.g., by distillation with an immiscible solvent or by titration with Fischer reagent).

Moisture free, in textiles: A descriptive term for a material that (a) has been exposed to a flow of desiccated air at a specified temperature until there is no further significant change in mass, or (b) has been treated by a distillation process using a suitable solvent.

Moisture pick-Up: The mass of absorbed and adsorbed water that is held by the material, compared to the mass of the dried material.

Moisture pick-Up, at atmospheric-equilibrium: The moisture pick up of a material in equilibrium with air of known, or specified, temperature and relative humidity.

Moisture Properties: All fibres when exposed to the atmosphere pick up some moisture; the quantity varies with the fibre type, temperature, and relative humidity.

Measurements are generally made at standard conditions, which are fixed at 65% RH and 70°F. Moisture content of a fibre or yarn is usually expressed in terms of percentage regain after partial drying.

Moisture regain: The amount of moisture in a material determined under prescribed conditions of temperature and humidity, compared to the mass of the dried material.

Moisture regain, of different fibres: The amount of water resorbed by a dried material at specified equilibrium conditions of temperature and humidity, compare to the mass of the dried material.

20.50 Alginate
 18.25 Wool combed top, worsted yarn
 17.00 Wool carded yarn
 15.50 Worsted yarn with 25% wool
 14.00 Reclaimed wool
 14.00 Caesin fibre
 13.75 Jute
 13.50 Zein fibre
 13.00 Viscose and cupro
 12.50 Jute
 12.00 Flax, hemp, Ramie
 11.00 Natural silk
 10.50 Cotton, Mercerized
 10.00 Flax, Hemp
 9.00 Acetate (de-oiled, desized)
 8.50 Cotton
 6.25 Polyamide 6 and 6.6 staple fibre
 6.00 Acetate (with 3% oil)
 5.75 Polyamide 6 and 6.6 filament
 3.00 Triacetate
 3.00 Polyester filament
 2.00 Polyacrylonitrile
 1.50 Polyester staple fibre; Polyethylene; Elastane
 0.40 Polyvinyl chloride
 0.00 Glass Fibe
 0.00 Polyethylene

Moisture regain, commercial: See **Commercial moisture regain**.

Moisture, wet-Basis: deprecated term, See **Moisture content**.

Moiting Process: Moiting process consists of picking out all sticks, leaves, etc., from the wool fleece in the sorting.

Moity wool: A term mainly used in UK for wool containing vegetable matter picked up by the sheep while grazing.

Mojo: Very tough, durable bast fibre of good elasticity, yielded by the m. tree in Honduras; used for ropes.

Mokho: Raw cotton grown in Senegambia. The staple is fine, silky and white.

Molaine: In England various fabrics, made of cotton warp and wool filling.

Molar: (1) Denoting a physical quantity divided by the amount of substance. In almost all cases the amount of substance will be in moles. For example, volume (V) divided by the number of moles (n) is molar volume $V_m = v/n$.

(2) Denoting a solution that contains the mole of solute per cubic decimeter of solvent.

Molarity: A measure of the concentration of solutions based upon the number of molecules or ions present, rather than on the mass of solute, in any particular volume of solution. The molarity (M) is the number of moles of solute in one cubic decimeter (litre). Thus a 0.5M solution of hydrochloric acid contains 0.5 . (1 + 35.5)g HCl per dm^3 of solution.

Molded garments: Textiles, which are brought out of the tubular form into the physically suitable form using mechanical/thermal deformation, e.g. for ladies' wear.

Mole: Essentially, an amount of a chemical equal to its molecular mass, but measured in grams, rather than atomic mass units; (more formally, amount of a substance containing approximately 6.02×10^{23} molecules or formula units) For example, sodium chloride has an molecular weight of approximately 28. Twenty-eight grams of sodium chloride would be one mole. If this was dissolved enough water to make one litre of solution, the solution would be said to be 1 molar sodium chloride.

Molecular weight: The weight of a molecule; the sum of all atomic weights of all the atoms in the molecule; expressed in atomic mass units (defined as exactly one twelfth the mass of a carbon-12 atom); this term is obsolete and should be replaced with molecular mass or relative molecular mass (r.m.m.) Water, for example, has a molecular weight of about 16 (for the oxygen) plus 2 (for the two hydrogens), or 18. The molecular weight of cellulose is in the millions. The concepts of molecular weight and moles are useful in understanding, among other things, *pH* and variations in effectiveness of different hydration states of a compound.

Moleskin: A strong cotton fabric slightly napped and sheared on the wrong side. It is similar to duvetyne but somewhat longer and closer nap. It is spun with a filling backed weave usually at a ratio of one face pick to two backing picks. A typical construction is 50 x 200 with 2/20s warp and 15s filling. Once only a cloth for protective clothing, particularly dungarees and trousers, because of its durability and additional warmth on the inside, but other fibres such as worsted may be used to produce good quality fabric for men's suits, and it is also made as aligning fabric. The term now refers to any cloth with short mole-like nap.

Molieton: French for Melton.

Molinos: (1) In Austria a plain spun cotton fabric, made of medium fine yarn; it is often printed and is used for shirts, etc. (2) In Mexican a variety of raw cotton, has a yellowish, glossy staple.

Molisch's test: For the testing of carbohydrates and/or their derivatives (e.g. methyl celluloses, cellulose glycolates, etc.). Two drops of a 10% solution of naphthol in chloroform are added to the solution to be tested and carefully lowered using concentrated sulphuric acid; a reddish violet ring is produced on the interface of both liquids. This reaction also takes place in the presence of proteins. Distinction: leave solution with reddish violet ring for 10 mins, then shake it. Deep blue dyeing of the whole solution = carbohydrates and/or their derivatives. Faint purplish brown dyeing = protein.

Mollet: In France, a very narrow fringe of silk or gold.

Molleton: Long-haired, soft wool material (lightly milled) with slightly visible weave under the hair surface; also in cotton, then thicker (e.g.: Beaver cloth; Kalmuck). The cotton molleton materials in practice represent a heavier type of beaver; they are also occasionally described as heavy flannel. They are also found in plain fabric and twill; raw dyed, bleached white and piece-dyed, more rarely designed yarn dyed. Heavier qualities are produced using backing weft. Molleton materials are always raised on both sides.

Mollier diagram: Gives information about steam conditions by means of isobars and isotherms. Describes the correlation between heat content and entropy(s) of the Steam.

Momie: (1) Cloth Black dyed dress goods of cotton or silk warp and wool filling. It is similar to crepe. (2) French for mummy. A cloth of puckered or fluted appearance.

Momme: Japanese weight, equal to 3.675 grams, used to measure and express the weight of silk fabrics. Weight of original Japanese silk for 1 yard length.

Monagum: A trade name for carboxy methyl starch, a starch ether

Moncahiard, Mocayar: Plain or twilled French fabric of silk warp and woollen filling. It is made mostly black.

Mon-Chirimen: A very fine Japanese silk crepe of high lustre, used for embroideries.

Monforizing: Continuous mechanical shrink proof finish on the monforizing system, consisting of padder as a damping system, nozzle dryer as a pre-drying system, palmer with overfeed device and felt calendar for final drying. Machine Manuf.: Monforts.

Monfor-Matic: Computer-controlled guidance system for heat treatment machines (e.g. stenters, hot flue, etc.) with processing sequence of measured values on screen in vertical arrangement (linearly indicating diode instrument); for central analysis and display stages of treatment sections. Mode of operation contact free, maintenance-free. Manuf.: Monforts.

Monk's cloth: See **Abbots cloth**. Made of wool, cotton, linen, silk, rayon, or synthetics in 4 x 4 basket weave. Quite heavy, due to construction. It is difficult to sew or manipulate as the yarns have a tendency to slide, stretch and fray. May sag in time depending on the compactness of the weave. It can also be made in other basket weaves. Quite rough in texture. Uses: (a) Draperies, all types of upholstery and house furnishings. Also used for coats and suits for women and sports coats for men. (b) Medieval English worsted, the piece measuring 12 yards by 45 inches.

Monkey-Jacket: A short jacket cut in the sack form, fitting close to the waist and flaring out at the bottom.

Monochromatic colour scheme: Monochromatic colour schemes comprise two or more colours that are variations of one hue. These colour combinations are considered to be harmonious due to the colour relationship.

Monochromatism: Colour blindness.

Monofil: See **Monofilament**.

Monofilament: A single filament which can function as a yarn in commercial textile operations, that is, it must be strong and flexible enough to be knitted spun or braided. Any single filament of a manufactured fibre, usually of a denier higher than 14. Instead of a group of filaments being extruded through a spinneret to form a yarn, monofilaments generally are spun individually. Monofilaments can be used for textiles such as hosiery or sewing thread or for nontextile uses such as bristles, papermaker's felts, fishing lines, etc.

Monomer: The simple, unpolymerized form of a compound from which a polymer can be made.

Montagnac cloth: A curly, woollen fabric with an astrakhan like pile, produced by cutting some weft floats and leaving others uncut. It is subsequently brushed to form a very warm and durable fabric.

Montbeliard: Stout French ticking, made with blue and white checks or cross stripes.

Montcayer: Fine French dress goods, mostly in black, made of silk warp and two or three-ply worsted in plain or twilled weave.

Monteiths: English cotton handkerchiefs with white dots over a colored foundation.

Monzome Shusu: Japanese silk satin, spun with stripes.

Mood/theme boards: Visual presentations of ideas to illustrate a mood or a theme.

Moon: Commercial variety of American cotton, maturing in medium time, the lustrous and strong staple measuring 30-35 millimeters; the yield is 31-33 per cent.

Moonga: Species of brown colored wild silk yielded by the *Antheraea* in Assam and East India. See **Muga**.

Moorish Lace: A drawn work of antique origin, still made in Morocco.

Mops: (type of steaming table for napped fabrics). Designation for the steam table used particularly in the finishing of brushed fabrics, which is built on in many cases.

Moquette: (1) One of the best known and hardest wearing furnishing fabric, used for covering cahirs, upholstery, curtains and drapes, tablecloths, etc., and probably the most popular until the advent of the more luxurious Dralon velvet. Moquette can be made three types, one with cut pile, another incut, and one combining cut and uncut. The pile is worsted, mohair, or nylon, the backing wool or cotton. Its great advantage is that, although apilecloth, it doesnot become flattened by pressure, eg., sitting on it.

(2) (a) Colourfully patterned Plush, manufactured using several pile warps or by printing (print moquette), then with smudged pattern contours; for upholstery covers, divan covers and similar. (b) Single-coloured, densely spun velour wire carpets. Designation also for carpets with corresponding appearance manufactured in a different way, e.g.

flocked carpets.

Moqui: Blanket Plain spun, all-wool blankets made by the Moai Indians in the U.S.A. The design consists mostly of black, blue and brown stripes.

Morzad: A bandhani design. See **Bandhani**.

Mora hair: Curly fibres yielded by the Southern moss, in the Gulf states and Central and South America; used for stuffing.

Moravian: English sewing cotton of 8 strands.

Mordant: A chemical that aids attachment of a dyestuff to fibres by bonding to both the fibre and the dye A mordant must have high affinity for both the dye and the fibre, acting to attach the dyestuff to the fibre. Mordants are necessary for dyes that have very low or no natural affinity for the fibre. They are often salts of metals such as chromium, copper, tin or iron. Mordants may

be applied before, with or after the dye, depending on the nature of the dye, the fibre and the mordant. The mordant (e.g. aluminum hydroxide or chromium salts) is precipitated in the fibres of the cloth, and the dye then absorbs in the particles. Some mordant, especially chromium compounds, are very serious health hazards.

Mordant dye: A dyestuff that requires the use of a mordant. There are very few synthetic dyestuffs currently in use that require a separate mordant, except for some dyes for wool, where mordant dyes are still quite popular. Since chromium is almost exclusively used as the mordant on wool, chrome dye has become essentially synonymous with mordant dye. Many natural dyes (plant extracts, etc.) require a mordant. The mordant used can significantly influence the hue produced with a particular dyestuff.

Mordanting: The process of impregnating textiles with some mordant, not dyestuffs themselves but usually salts, which will fasten the dye applied after.

Morea: Variety of raw cotton from Greece.

Moreas: Fancy striped satin of cotton warp and silk filling, finished with high gloss.

Moreen: (1) Originally a Dutch, all-worsted, cross ribbed camlet, with a moire finish; (2) A plain spun stout fabric, made in England, one side ribbed and watered and the other made smooth with a high finish. It is made of hard spun worsted, but also of cotton, in the latter case the filling being polished yarn. Used for skirts (formerly) and for upholstery.

Moresque: A multicolored yarn formed by twisting or plying single strands of different colours.

Morfil: Stout, twilled, Belgian worsted fabric used for bags for pressing oil.

Moriche: Very tough and durable leaf fibre yielded by the Ita palm in Venezuela; used for cordage.

Morocco leather: A term now refers to leather that has been tanned chemically although it once referred to leather only from Morocco.

Morpholine Test: For the rapid identification of certain man-made fibres. The following characteristics result when immersing in morpholine (morpholine): polyvinylidene chloride fibres: slightly darker, after a few minutes morpholine becomes opaque and dyed almost black. Polyvinyl chloride fibres, post-chlorinated: dissolve clearly reddish brown. Polyvinyl chloride fibres, not post-chlorinated and vinyl chloride vinyl acetate copolymer fibres: no effect.

Morphology: The study of the fine structure of a fibre or other material. (Gk.: morphe = form/shape; logos = science), science of structure, shape formation and surface structure, e.g. of textile fibres. The morphology of a fibre loading

is of particular importance to the finisher, i.e. for example the order structure and the clearance volume.



Morphology of a fibre arrangement using the example of a rope.

Morris Rug: Closely spun modern English rugs, dyed with vegetable dyes and having simple floral, usually acanthus designs. Named after William Morris, its originator.

Morrison: A Highland tartan composed of green, black and blue stripes and white and yellow stripes over a red ground.

Mortling: Name in England for wool taken from dead sheep.

Mosaic Canvas: Very fine embroidery canvas, made of silk or cotton.

Mosaic Lace: Modern Venetian bobbin lace, the patterns being composed of many small sprigs and medallions applied to a net ground.

Mosaic Rug: A cut pile rug, made in England, the pile of which is glued in colored pattern to a canvas foundation, instead of spun to it.

Mosambique: (1) Woollen dress goods with the nap raised in squares, dots or other 'figures; (2) A light, sheer French fabric, made with yarn dyed cotton warp and mohair filling; comes in stripes and checks.

Moscovite: A dress silk, spun with organzine warp and cotton filling, forming ribs; comes mostly in light colors.

Moscow: Heavy, shaggy woollen overcoating.

Moscow canvas: Made in fancy patterns with gold, silver, blue and black threads interwoven, resembling plaited straw. Used for embroidery.

Mosey: An under-jacket, usually made of baize or flannel, and worn instead of an undershirt, usually under the vest, but over the shirt in cold weather, but in moderate or warm weather as an outside garment, and is also called a "wammus."

Mosquito bar: Similar to mosquito netting, having several warp and weft threads placed closer to each other at regular intervals.

Mosquito netting: An open face, very light cotton fabric, nowadays more with synthetic fibres, spun in gauze weave, dyed in solid colours.

Moss: Yarn Coarse woollen yarn of fuzzy or nubbed surface, used for embroideries.

Moss crêpe: (mimosa), small patterned garment crêpe with mossy character made from viscose delustrated in spinning.

Mosses: Large hanks of reeled silk, weighing about one pound each, produced by the natives of China in the home industries.

Mossing: In England same as napping.

Mosul embroidery: The Oriental patterns are filled closely with herringbone stitch and are heavily outlined.

Mosul rugs: Made in (Mesopotamia, usually all wool, but warp and weft are, sometimes, of cotton and the soft, silky pile of goat's or camel's hair, tied in Ghiordes knot. Yellow and brown colors are often used. The design consists of various geometrical patterns and several border stripes. The ends are finished with a narrow web or fringe.

Mota: Thick cotton cloth made in India.

Motchenetz: Trade term for Russian, water retted flax.

Mote: A small piece of seed or vegetable matter in cotton. Motes are removed by boiling the fibre or fabric in sodium hydroxide, then bleaching. When not removed, they can leave a dark spot in the fabric.

Mote (2), in raw cotton: Whole developed seed or seed parts of any size or age covered with Fuzz and short fibres and in rare cases, some mature lint fibres.

Mote knife: Doctor blade.

Mote trash: See **Trash**.

Motes: Appearance of fault in cotton in the form of fibre knots felted into each other as growth motes (skin residues, unripe and dead cotton, moisture effects, etc.) or processing motes (torn and spun together, chiefly ripe fibres, which are produced in the ginning and on the carding machine). This also includes the so called small husk motes with fragments of outer husk and with them frequently complete bundles of Cotton fibre tufts.

Mother-of-all: The whole stand that supports the maidens, bobbin, and flyer.

Mothproofing: Mothproofing is a chemical finishing of fabric to prevent the growth of , fur moth (and/or their larvae), the anthremus, attagenus beetle, etc., which live as Textile parasites on keratin-containing substances (wool

amongst other protein fibres, fur, duvet feathers, etc.). Also called **Insect repellent finishes**. Mothproofing agents should also protect against carpet beetles amongst other harmful insects. Insecticides are more or less poisonous. The earlier used DDT, Dieldrin etc. is banned in almost all countries. These have been replaced by other chemicals which are not poisonous to human.

Motley: (1) Medieval English mixture worsted, 7 yards long and 45 inches wide: (2) Same as mixture.

Motif: Recurring element in a design.

Motif print: Self-coloured or two-colour, if necessary, also multicoloured print of individual figures, emblems or strokes with the aid of printing screens of different sizes, usually in accordance with the pigment printing process. Predominantly made from tricot on semi-finished or finished products.

Motril: Variety of raw cotton from Spain. It has a white to reddish yellow, lustrous, strong fibre.

Mottle Yarn: Yarn which is mottled.

Mottled: Mixed (bright/dark), speckled, checked. See **Colour blend**.

Moufflin: A double faced thick coating fabric which is soft and has an open, airy surface. The yarns used are mainly wool, or wool mixed with acrylic or mohair. Used for coats and capes.

Moulding: Seamless shaping of textiles made from thermoplastic man-made fibres.

Moule: Soft, thick but light woollen overcoating, made in France.

Moulinage: French for silk reeling.

Mountain flax: Another name for asbestos.

Mountmellick embroidery: Raised Irish embroidery, executed on a heavy, firm fabric with a number of heavy, fancy stitches. The design is in natural or conventionalized flowers, leaves and also scrolls.

Mourning crepe: Is a dull black fabric which may or may not be given a moiré effect.

Mousseline: The French word literally means muslin, but we used it to describe a better quality wool or silk fabric of this nature. General name for a broad range of soft, sheer, light weight, plain spun fabrics made from cotton, silk or finer than muslin.

Mousseline de Laine: Plain spun, soft, light and open fabric, made of fine gassed worsted yarn, often mixed with cotton and somewhat heavier than Mousseline.

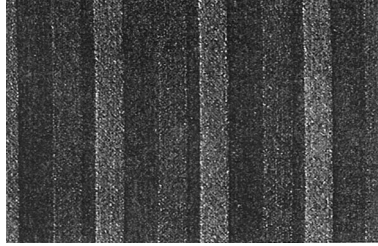

Mousseline De Soie: A plain and open weave fine and light fabric, made of silk. It is silk muslin. Sheer, open, and lightweight. It is something like chiffon but with a crisp finish produced by sizing. It does not wear well and it does not launder. *Uses:* Evening wear, and bridal wear. Trimmings. Also used in millinery as a backing.

Mouth width, in Zipper: The measurement between the slider flanges at the point where they bear against the shoulders of the interlocked elements or at the outermost edges of the bead if the bead extends beyond the elements.

Mouth, in Zipper: The opening in a slider that receives the chain.

Movable Retainer, In Zipper: A movable or sliding device performing a similar function to that of the fixed retainer, the purpose being to permit separation of the two stringers from the bottom, without necessity of opening the zipper from the top.

Moving bed biological reactor: M. B. bioreactor, m. b. biofilm reactor, MBR, MBBR, suspended immobilised (immobilized) biomass reactor, SIBR Plastic media is used in an *activated sludge* aeration tank so that biomass can grow on and in the solid media together with the normal suspended bacterial culture in the tank. The plastic media is in suspension in the aeration tank and mixing is normally by diffused air but mechanical mixing may be used. The aeration tank is followed by a sedimentation tank and settled activated sludge from the sedimentation tank may or may not be returned to the start of the aeration tank, depending on the design. The media is often small hollow polyethylene cylinders but other designs have been used including 12 mm cubes of polyurethane pads (LINPOR process). The addition of the media can relieve an overloaded activated sludge plant or allow an existing plant to have extra treatment capacity. When this system is utilised as a *roughing filter* loadings of 4 kg BOD/d per m³ of aeration tank have been achieved, although loadings of 1 kg BOD/d per m³ of aeration tank are more typical for full treatment.

Moving bed scrubber: Floating b. s. A *wet scrubber* containing spheres of plastics, glass, marble, etc., which are fluidised by dirty gas rising up through

them. The wash liquor is sprayed down over the spheres. The pressure drop is directly proportional to the flow rate of the liquor. Particles of 0.1µm size can be collected, as well as viscous liquids. If the spheres are of hollow plastics, they may need to be held down by an upper constraining plate. There may be more than one bed. These scrubbers are efficient in the absorption of sulphur dioxide when using a caustic scrubbing liquor.

Mouth width: of zippers: The measurement between the slider flanges at the point they bear against shoulders of the interlocked elements or at the outermost edges of the bead if the bead extends beyond the elements.

MPI (Multi Product Injection): A dispensing system in which you can programme for dye and chemical addition for dyeing and finishing processes (Thies)

MR Process: (Menschner, Rotta), for wool fabric fixation. An enhancement in the quality of wool fabrics is possible in the MR process through the combination of physical treatment and chemical finishing.

Ms: Mulberry silk.

MSDS: Material Safety Data Sheet. This is a reasonably detailed specification for the possible safety hazards associated with a product. They are prepared by the manufacturer of the product. Unfortunately, they are often not available for products that are regarded as “consumer” products, even if the product poses serious safety hazards. For an excellent Internet resource for MSDS and other safety information, try www.siri.org/msds or www.hazard.com/msds

MSI: Magyar Szabványügyi Intézet, Hungarian Standards Institute.

MSZH: Hungarian Standards Association.

MTF: Metal fibres.

Mucuna: Strong leaf fibre, yielded by the *Mucuna urens* in Brazil; used for ropes.

Muddai: Very strong, silky fibre, yielded by a species of *asclepias* in India; used for ropes. It is mixed with cotton when spun; has good affinity for dyes.

Muff: A loose skein of textured yarn prepared for dyeing or bulking. In the bulking operation, the yarn contracts and the resulting skein resembles a muff.

Muff dyeing: See **Dyeing**.

Muga: (1) Species of brown wild silk, yielded by the *Antheraea* in Assam; (2) Stout, coarse silk fabric, made in India.

Muga cloth: Also called Assam silk. It is obtained from a species of Indian moth, and is wild silk producing a rough surfaced lightweight fabric.

Muga silk: This golden yellow silk is the prerogative of India and is the pride of Assam state. It is obtained from semi-domesticated multivoltine silkworm *Antheraea assamensis*. These silkworms feed on the aromatic leaves of Som and Soalu plants and are reared on trees similar to that of the tasar. Muga silk is a high-value product and is used in the manufacture of products such as sarees, mekhalas and chaddars.



Muka: Native name for the fibre yielded by the New Zealand flax.

Mulberry: A plant whose leaves are eaten by silkworm.

Mule spinning frame: A spinning machine invented by Samuel Crompton in 1782 and termed “mule” because it was a combination of the machines invented by Arkwright and Hargreaves. It was once widely used for spinning wool and to a lesser extent for very fine counts of cotton yarn. Its action was intermittent and slower than that of the more current ring spinning frame. It drew out and twisted a length of yarn and then wound it in the form of a cop, or bobbin, then repeated the cycle. See **Spinning frame**.

Mule yarn: Single, more or less (loose) twisted cotton weft yarn for soft materials, as a filling weft and similar.

Mull: A type of lightweight cotton voile, which was once a dress fabric but is now almost entirely confined to use as an underlining fabric. It is also used for eastern turbans. Lawn, voile and cabric give better service in wear as dresses and shirts, but not mull.

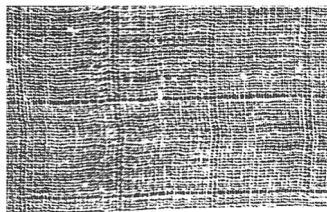

Mull Muslin: A fine, undressed white muslin; used for dresses.

Mulmul: Closely spun East Indian cotton muslin. See **Mull**.

Mullen bursting strength: An instrumental test method that measures the ability of a fabric to resist rupture by pressure exerted by an inflated diaphragm.

Multan: Knotted rugs made in India. They have geometrical designs in deep blues and reds.

Multiaxial fabrics: The structure results from several layers of monoaxial fabrics (fleeces, fabrics; see Fig.) arranged shifted together. The resulting physical properties such as strength and extensibility are clearly above those of monoaxial arrangements.

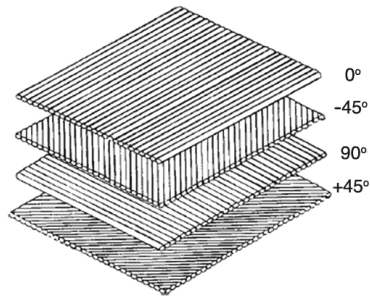

Multiaxial composite material.

Multibath Process: American description for multi-purpose baths, which facilitate various finishing stages in one bath.

Multicellular: Multicell, e.g. viscose fibres with a thin cell wall structure and triangular diameter.

Multicoloured effect: Achievement of heterochromatic marks using discharges, printing, fixation differences, resists, weaving and similar on textile fabrics.

Multicolour effects: Multicolour effects on textile fabrics; e.g. Colour craft process; Differential dyeing or also spray dyeing effects, e.g. on fabrics in special machines

Multicomponent fibre: Bicomponent fibre made from various synthetic fibre components of the matrixfibril type.

Multi-phase weaving machines: In these looms, during the weaving operation several sheds are opened simultaneously and weft is inserted in them by several carriers. Several phases of the weaving cycle take place at any instant so that several picks are inserted simultaneously.

Multifibre strip: A strip of fabric made using different fibres and is used in washfastness testing to assess the staining rating of a dyeing on different fibres.

Multifilament: A yarn consisting of many continuous filaments or strands, as opposed to monofilament which is one strand. Most textile filament yarns are multifilament.

Multifilament yarn: See **Multifilament**.

Multiflora: Commercial variety of early ripening upland cotton from Alabama, the medium long staple forming clusters of bolls.

Multi-liner, in ETP: A lining system at the base and sides of a *landfill* site in which more than two liners are installed. This may be appropriate for landfill sites containing very hazardous waste material. The liners may be three or more separate liners with drainage layers above each liner. Alternatively, the first two layers may be a *composite liner* and then a third liner is placed below with a drainage layer between the composite liner and the third liner. Drainage layers are also installed above the composite liner to collect the leachate and below the third layer.

Multi-media filter, multi-layer filter., mixed media filter: A downflow *rapid gravity filter* that uses three or more media, often anthracite at the top (coarsest and least dense), sand in the middle and garnet (finest and most dense) at the bottom. Polystyrene may be added as an extra layer on top and magnetite as an even finer, denser layer at the bottom. Other materials have been used and they should be chosen to suit the water or effluent to be filtered. The grain size varies from 1 to 2 mm at the top to less than 0.5 mm at the bottom to give *coarse to fine filtration*. The filters are backwashed, but because of the differing densities of the various media, the layers remain separated after *backwashing*. Water works may adapt their *rapid gravity sand filters* to become multi-media filters in order to increase the throughput of water.

Multilobal cross section: See **Cross section**.

Multilevel pile: For pile yarn floor covering: Pile in which some tuft legs are substantially longer than others.

Multiple gripper weaving machine: This projectile weaving machine is a versatile unconventional loom a gripper projectile transports a single weft yarn into a shed. It has the advantage of a combination of wide width and high speeds.

Multiple length staple fibres: Manmade staple fibres that are two or more times the nominal cut fibre length.

Multiple stitch zigzag, in sewing: A simple machine stitch pattern of alternating diagonal segments with each segment of two or more stitches having equal length and width.

Multipolymer fibre: See **Copolymer Fibres**.

Multipore fibre: See **Imitation Suede**.

Multi Product Injection: See **MPI**.

Mummy canvas: Similar to Mummy Cloth, but with a coarse mesh and an irregular, rather than creepy surface. Used for embroidery.

Mummy cloth: Also called Grannie cloth and Momie cloth: A fabric with a crinkled surface like crepe, but made with non-crepe yarns and spun on a dobby loom. It can be bleached, dyed or printed. The fibres include silk warp and woollen filling or cotton with silk. The fabric lacks lustre, and has been a traditional mourning fabric, but is not used much now. The name is also used for fine linen fabric used in Ancient Egypt, for wrapping Mummies.

Munj: Strong and elastic fibre which stands water well; is yielded by a species of the sugar cane in India; used for ropes, mats, and baskets.

Mungo: (1) Also Called Shoddy. A cheap, poor quality woollen cloth made from mill wastes. Because the fibre staple is too short it does not wear well. Colours are often poor and drab. It is normally not used for clothes but may be used for some types of stage costumes.

(2) Waste yarn from woollen mills which is mixed with other yarn, such as cotton to produce cheap cloth for special use such as backing fabric.

Munroe: A Highland tartan, composed as follows: Wide red stripe, split near each edge by a thin blue and yellow line, the two lines placed next to each other, the blue being on the outside; *green stripe, half the width of the red; red stripe, half the width of the green, split in the center by a narrow blue and yellow line, placed next to each other; dark blue stripe, half the width of the green; *red field, one and one half times wider than the first red stripe mentioned, split near to each edge by a narrow yellow and blue line (placed next to each other with the yellow line on the outside) and split in the center by three green stripes, spaced from each other by their own width; repeat, in reversed order, groups mentioned between the two (*).

Munsell Colour Charts: A three-dimensional colour system developed by Albert Munsell that is based on the attributes Munsell Hue, Munsell Value, and Munsell Chroma.

Munsell colour system: The colour identification of a specimen by its Munsell hue, value and chroma as visually estimated by comparison with the Munsell Book of Colour.

Murata® Spinning: See **Air jet spinning**.

Murga: Native name of the Indian bow string hemp.

Muriatic acid: An antiquated but much-used term for hydrochloric acid. Most muriatic acid sold in hardware stores is as strong as commercial hydrochloric

acid sold for laboratory purposes. Sometimes it is somewhat diluted, but still is dangerous and must be handled with great care.

Murray of Athole: A Highland tartan, composed as follows: Green stripe, split by a red line in the center; black stripe, half the width of the green; dark blue stripe, a little wider than green one, split in the center by a red stripe, outlined with a fine black line; black stripe, as above; green stripe, split by red, as above; black stripe, as above; dark blue stripe, twice as wide as the black, split near each edge by a pair of narrow black stripes, spaced from the edge and from each other their own width.

Murray of Tullbardine: A Highland tartan, composed as follows: Red stripe; group (twice as wide as red stripe), consisting of fine blue line, fine red line, black stripe, fine red line, fine blue line, red stripe, blue stripe, red stripe, fine blue line, fine red line, blue stripe (narrow), fine red line, fine blue line, red stripe, blue stripe, red stripe, fine blue line, fine red line, folack stripe, fine red line, fine blue line; red stripe, as the first one; *dark blue stripe, little less than half the width of the red; red stripe, as wide as the blue, split by a fine green line near the edge next to the blue; green stripe, half the width of the first wide red*; red stripe, almost twice as wide as the green, split by two blue and a narrower black stripe; repeat, in reversed order, stripes mentioned between the two (*).

Mururuni: Leaf fibre, yielded by a palm in Brazil; used for hats, baskets, etc.

Mushroo: An Bast Indian cotton back silk satin, figured with white or gold flowers, some having wavy stripes of yellow and gold.

Mushroom apparel flammability tester: See **Flammability tests, Mushroom apparel flammability tests.**

Mushroom test: A test developed by American National Bureau of Standards Using Mushroom Apparel Flammability tester

Mushy wool: Dry, fuzzy wool, yielding large percentage of noil in combing.

Muslin: Named after the palce Mosul in mesopotomia. Soft spun cotton, very open weave, with a rough finish. Ideal to use as a pressing cloth. Muslin as a dress fabric is rarely used now mainly due to the heavy shrinkage of this fabric. A characteristic construction is 64 square with 30s warp and 40s filling common widths are 30, 36, and 40 in.

Musimet: Coarse cotton muslin, usually sized.

Muslinette: In England a thick variety of muslin; used for dresses.

Muslin, as applied to bedsheeting: A plain weave fabric with not fewer than 180 yarns/in².

Muslin (Silk): Slightly transparent flowing fabric, made of warp of crepe threads with an S or Z twist and weft of crepe threads with 1S/1Z twist.

Musquash: The coat of Musk-rat. It is a long downy, grey fur with darker brown, but is often dyed to various colours including pale honey.

Muss resistance (Wrinkle Resistance): The fabric must not wrinkle when a garment is worn. Wrinkling performance can be expressed in crease recovery terms. Crease recovery angle are used to measure crease resistance or crease recovery.

Mussel silk: (byssus silk, sea silk, etc.), natural silk-like hair of different large ham mussels (Mediterranean, Normandy) belonging to the Natural protein fibres, which are held tightly on the rocky ground with the fibre tuft produced and are torn off there. Reconditioning by kneading by hand using soap, carding, drying, washing using citric acid and hot platelets. Outer smooth, gold shimmering gloss, colour brown to olive green. 2–3 threads of mussel silk are twisted with a barely 200 kg/year. Application: (Italy) for shawls, stockings, gloves, bags, etc. thread of natural silk. Precious, rare material. Production

Mussiness: Surface distortion in a fabric characterized by undesirable unevenness due to many minor deformations.

Mutagenic agents: (Lat.), substances hazardous to health, which damage hereditary factors and trigger mutations, i.e. can cause changes in hereditary makeup.

Mutagenic agents also partly act as Carcinogens.

MUT: (environmental-friendly textile label). Label for textiles kind to the environment, awarded by the Verein für verbraucher- und umweltfreundliche Textilien

MX Dye: A family of “cold” reactive dyes, first developed by Imperial Chemical Industries of Britain, and designated “Procion MX”; chemically MX dyes belong to the dichlorotriazine family A number of companies now manufacture MX dyes. They are by far the most popular dyes for textile artists working with cellulose fibres. They can also be used for wool and nylon in processes where they behave as acid dyes. There are around a dozen “pure” MX dyes in common use, and all can be used quite successful in mixtures with each other. There are magenta, yellow and cyan shades that are excellent “subtractive primary” colors. MX dyes are less popular with industrial dyers than some other reactive dyes, partly because their very high reactivity makes the dye process harder to control, partly because they are fairly expensive, and partly because goods require extensive washing after dyeing to remove

hydrolyzed and unfixed dye. Care should be taken to avoid breathing MX dye dust, since it is known to cause respiratory allergies. The use of "Procion" alone to denote MX dyes is incorrect since there are other Procion dye families.

MWS: (metres head of water). Metre water column. Unit for Pressure (-heights, liquid columns) no longer in use. $10 \text{ MWS} = 9806.65 \text{ Pa}$.

Myrobalans: Tannin-containing, small rock hard fruits (Bengal, India) and/or fruit parts or their extract. Good myrobalans have a wrinkled exterior and contain 38–40% tannin; worse are smaller, unwrinkled with 25% tannin content. Stoned myrobalans have approx. 50–53% tannin content, 24–34% liquid and 65% solid extracts. Good myrobalans correspond approximately to 1/3 tannin. Used as tannin for tanning.

Mysore Silk: Soft, fine, undressed south Indian silk dress goods, made plain, dyed or printed, mostly in floral patterns.

N

Nabo: Native name of the strong fibre, yielded by the Nauolea in the Philippines; used for cords, ropes.

Naboika: Russian homespun linen, printed with fast colours by means of wooden blocks; used for clothes, religious vestments, covers, etc.

Nacarat: (1) Orange red coloured fine linen in Latin-America; (2) In Portugal a fine crepe or muslin, dyed in flesh colour, which is used by women as rouge.

Nacre': (1) (Fr.), Nacré print, flowing print; like mother-of-pearl, iridescent, changeable effect; (2) Silk fabrics woven in colours producing effects similar to the mother-of-pearl.

Nacre' velvet: A velvet in which the backing is woven in a different colour from the pile, giving an interesting, changeable appearance in wear. See **Velvet**.

Nae: Hawaiian name for a netting, having a very fine and close mesh; used for garments.

Nail: 2¼ inches.

Nainsook: A soft, fine, light cotton fabric made from combed yarns, in plain weave, often mercerized, similar to Batiste in the piece. The construction and the yarns used in nainsook is the same as that of lawn. A lawn fabric which is not given the starch finish to make it crisp is actually nainsook or English nainsook. In case of French nainsook it may be slightly starched and calendared. Once a popular dress fabric but now mainly used for lingerie and baby clothes or for summer dresses and curtains.

Nak: Medieval name for cloths of gold.

NALCC: A leading American specialist textile cleaning organization.

NALI: English textile cleaning specialist organization.

Namad: Felted carpets of Persia and India.

Namazlik: Turkish name for prayer Rugs.

Named: Persian felt rug with patterns of coloured wool pressed into it. See **Namad**.

Nambali: Silk fabric with religious names printed on; used for garments in India.

Namdaz: (1) Felted woollen cloth, made in Tibet. Is often embroidered and used for rugs and carpets.

(2) Felt rugs, made in Kashmir, India. Often embroidered by men with chain stitch crewel work embroidery.

Namitka: A fine sheer veil, woven in southern Russia from homespun silk by the peasants and used for head ornament.

Nanako: Plain woven Japanese silk fabric.

Nancy: Embroidery French needlework, combining embroidery in coloured silk with drawn work.

Nanduty: Very fine lace made of cotton or pita fibre in South America. It is made in small squares joined together.

Nankeen: (1) A peculiar fabric of a pale dull yellow or orange colour, woven out of the fibrous tissue which lies between the outer and sap-wood of a tree or shrub that grows in the East Indies and especially in China. The name is derived from the city of Nankin. An imitation is made out of cotton, coloured with Annato. The genuine nankeen is never more than eighteen or twenty inches wide and is used for light summer clothing. (2) Cotton cloth in Roumania, having a white warp and pink, red or yellow coloured filling; it is finished with a size. (3) English and French all-cotton, very stout, plain, woven fabric, dyed in the yarn and made in solid colours, stripes, with equal number of threads in the warp and weft in a square inch; used for clothing.

Nankin ticking: See **Ticking**.

Nankinet: (1) Similar to nankin but not woven as close; (2) Fine, fancy coloured percales.

Nano-: Symbol: n A prefix used with SI units, denoting 10^{-9} . For example, 1 nanometer (nm) = 10^{-9} meter (m).

Nanofiltration, in ETP: Filtration of treated water through membrane assembly sieve having pore size lower than 2nm, applying hydrostatic pressure difference to filter small molecules down to a molecular weight of 200, some hardness and viruses. Typical operating range of pore size will be 0.001-0.01 μ m. The operating pressure is 10–40 bar which is less than *reverse osmosis* but higher the *ultrafiltration*. Nanofiltration can filter out micro-organisms, organic and colour molecules and some larger salt molecules from water.

Nanotechnology: The technology of devices at the nanometer scale. In such small devices the quantum mechanical nature of electrons has to be taken

into account fully. Instruments such as the ATOMIC FORCE MICROSCOPE which can identify and manipulate individual atoms are very useful in nanotechnology.

Nanometer: (nm) – Unit of length equal to 10^{-9} meter (a.k.a. one billionth of a meter, or a milli-micron).

Nansu: Nainsook in Venezuela.

Nap, in raw cotton: A large mass of curled or matted unorganized fibre or fibres that is found after opening and picking, but which disappears during carding and subsequent processing.

Nap: The downy substance, covering either side, entirely or partly, of a woollen or cotton fabric. It is formed by the loose fibres of the warp or weft threads, and is produced by scratching the cloth and thus raising the nap. In this respect it is distinctly different from the pile (see) which is always formed by a cut yarn separate from the ground of the cloth.

Nap cloth: The term used to describe thick, soft double fabrics (900–1000 g/m²) made from carded yarns usually of high quality merino wool. The typical appearance is achieved by a separately-inserted 3rd weft thread, the nap weft, which is a long float thread, later napped (thus also called the “raised thread”) giving rise to fluffy tufts of hair on the surface of the fabric. Depending on weave, comes in ribbed, diagonal or herringbone effect; wool dyed or piece-dyed. Used for high-quality men’s coats.

Nap finish machines: Mainly Brushing machines for the production of brushed or napped finishes on grey goods. In the widest sense they also include Raising machines.

Nap velours: A napped fabric, usually wool, in which the raised fibres all lie in a parallel direction. Opposite Upright pile velvet.

Nape: The starting point from which the length and the shoulder measures are taken for a coat. A vertebral protuberance located on the back central part of the neck at its junction with the thorax or trunk.

Napery: Table and household linen.

Naphthalene C₁₀H₈: Consisting of two contiguous benzene rings. A product of crude oil (rare) and coal tar. Small white laminations with a distinctive smell. Insoluble in water, soluble in organic solvents.

Naphthalene process: A pad steam process for the continuous dyeing of loose wool, with the addition of emulsified naphthalene.

Naphthol dye: See Naphthols.

Naphthol dyeing: Naphthol dyeing is carried out on the fibre by combining (coupling) two soluble components, a naphtholate and a diazotized base. The base is either diazotized in the dye shop itself, a complicated process, or obtained from the dye manufacturer as a stabilized diazotized fast colour base, the dyeing salt. There is a large number of combinations, capable of achieving bright yellow, orange, scarlet and red shades which are not available in the vat-dyeing ranges, and more muted burgundy, brown, navy blue and black shades. Naphthols are characterized by good fastness, in particular fastness to boiling. Some combinations are also weather-resistant. The dyeing technique for naphthol dyeing requires promoting the main reaction to form an azo dye, and avoiding the secondary reaction of hydrolysis to a compound no longer suitable for coupling.

Naphthol dyeing test in UV light: Place a test dye sample in a 50 ml beaker, and fill with sufficient blank vat to cover the sample (36 g/l caustic soda, 35.5% and 24 g/l sodium hydrosulphite); boil until the original dye appears a dirty yellow; remove the sample with a glass rod, squeeze the sample out on the glass side of the beaker, place on a round filter paper (preferably on a glass base) and leave to dry. Examine the test samples under an analytic quartz lamp: strong luminescence indicates naphthol dyeing.

Naphthols; Naphthol dye: (1) Name of hydroxy-derivatives of naphthalene with one or more OH groups. They are used as intermediate products (α -naphthol, β -naphthol) in dye synthesis (Phenols; Cyclic hydrocarbons). (2) Developing dyes (obsolete ice colours), produced on the fibre, usually by means of a two-bath application, they are insoluble azo dyes from naphthols (primers) and fast colour bases or dyeing salts (developers), with around 2000 combinations possible.

Naphthols in direct printing: Naphthols can be directly printed by many methods. (1) Low affinity naphthols can be padded and dried on a hot flue and printed with diazotized fast colour salt. The ground naphthols are removed in subsequent soaping along with an alkali binder. (2) Low coverage prints can be done by printing naphthols, dried and padded with diazotized fast colour salts. (3) Fabric is printed with naphtholate, antediazotate, caustic soda and weak oxidizing agent and dried. The non-developed antediazotate can be converted into a developable diazo compound by steaming and subsequent passage through a hot electrolytic bath containing formic acid, acetic acid or by steaming in acid ager, rinsing and boiling with soap. (4) Fabric is printed with a combination of naphtholate and diazoamino compound, wetting agent and caustic soda (suitably thickened) are printed, dried, with acid bath treatment and finally soaped. (5) Fabric can be printed with a combination of naphtholate and antediazosulphonate. Also fixed using neutral steam.

Naphthols in discharge printing: Most Naphthol dyeings can be discharge printed because of the ease of splitting of the azo pigments with the help of reducing agents.

Naphthols in resist printing: Mainly of academic interest, naphthols can also be used in resist printing. (a) White resist can be printed with aluminium sulphate along with an organic acid like tartaric acid (suitably thickened). (b) Coloured resists can be printed especially with reactive dyes. The goods are printed, dried, briefly steamed, padded with slightly thickened variamin blue, ventilated, rinsed briefly, immersed in a boiling bath with sodium disulphite, rinsed, boiled with soap with sodium carbonate.

Naphthoquinone: Dyes of the anthraquinone naphthalene derivatives. Dyes can be made by condensation of 5-aminobenzo- α -phenazine-4-sulphonic acid with 2,3-dichloro-1,4-naphthoquinone.

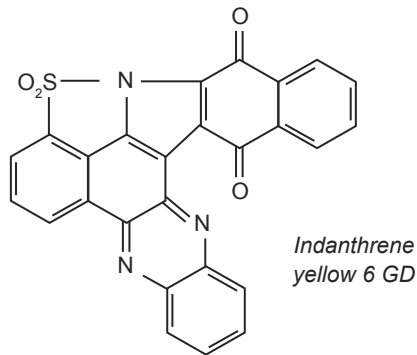

Naphthoylene-benzimidazole: Dyes of the anthraquinone naphthalene derivatives. Example is the dye made by heating a mixture of o-phenylenediamine and 1,4,5,8-naphthalene tetracarboxylic acid in glacial acetic acid or pyridine solution.

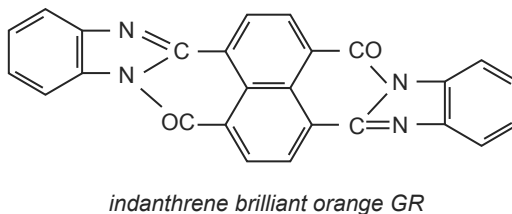

Napiei: (1) Double faced coating with wool face and vicuna or goats' hair back. (2) Good grade of floor matting, made of hemp and jute.

Napier Cloth: A once-popular double-face cloth for women's wraps, one side wool, the other of hair.

Napolitaine: A French flannel, originally made with all-woollen warp and filling, loosely woven, not fullled, and dyed in the piece, striped or printed; used for dresses, scarves, etc.

Nappa leather: This is the skin of sheeps or goats that has been tanned by a Californian Process using oil.

Napping: A finishing process that raises the surface fibres of a fabric by means of passage over rapidly revolving cylinders covered with metal points or teasel burrs. Outing, flannel, and wool broadcloth derive their downy appearance from this finishing process. Napping is also used for certain knit goods, blankets, and other fabrics with a raised surface.

Narrow band pass radiometer: A relative term applied to radiometers that have a bandpass width of 20 nm or less at 50% of maximum transmittance and can be used to measure irradiance at wavelengths such as 340 or 420, \pm 0.5 nm.

Narrow elastic fabric: An elastic fabric that is less than 150mm or 6 in. in width.

Narrow fabric: A textile fabric not exceeding 300 mm. in width. This includes tapes, ribbons, and webbings. They can be produced from any textile fibres, including elastomers by weaving, braiding, knitting or by any other methods. They can also be made by cutting or slitting wider fabrics into narrow strips.

Narrow fabric dyeing: Narrow fabric lengths are wound into hanks and dyed in a circulating-liquor machine like yarns on sticks or wound directly onto bobbins. Wider narrow goods are dyed by the continuous process.

Narrow Fabric: A textile fabric not exceeding 300 mm. (12 in.) in width.

Narrow fabric finishing: Narrow fabrics are woven in working widths of up to 300 warp threads, but usually as narrow textiles substantially less in width, on special looms, and it is in this form that they must be heat-set or crease resistant finished (possibly following pre-treatment and/or dyeing). This is carried out on cylindrical dryers, around which the narrow fabric passes several times.

Narrow-Fall: A small flap closing the opening in the front of trousers, with two or three button holes at the top and corresponding buttons sewed on the waist-bands, to which it was buttoned. See **Front-Falls**.

Narrow Wale: Narrow diagonal ribs, round or flat, on some woollens and worsteds.

Narrowing, In knitting: The reduction of the number of stitches for the purpose of shaping.

Narumi-shibori: Japanese cotton and silk crepes, dyed as follows: After taken from the loom the fabric has many small knots tied into it by means of wax thread and placed in the dye. After taken out of the dye, the wax thread is removed, leaving behind spots untouched by the dye. These spots form small conical prominences, as the dye also slightly shrinks and crinkles the fabric.

Nate: A French mercerized cotton cloth.

Natte: French term for a basket weave silk fabric made with different coloured warp and filling.

Natural (Lat.): Original, e.g. cotton can be called a natural cellulose fibre in contrast to regenerated cellulose fibres (viscose, acetate). Natural protein fibres are wool and silk, in contrast to man-made protein fibres such as casein fibres.

Natural: Refers to undyed or unbleached cotton or wool.

Natural cellulosic fibres: belong to the group of natural fibre materials of vegetable origin:

- (a) Vegetable hair fibres: Cotton; Kapok.
- (b) Bast fibres: Flax; Hemp; Jute; Kenaf; Kendyr fibre; Nettle fibres; Ramie; Rosella; Sunn fibre; Typha fibres; Urena fibres.
- (c) Hard fibres: Agave fibres; Alfa grass; Bromelia fibres; Coir fibres; Henequen; Manila fibre; Mauritius hemp; Sea jute; New Zealand flax; Palm fibres; Panama; Pine apple fibre; Raffia bast; Sanseviera fibre; Sisal; Yucca fibres.
- (d) Others: Paper yarns.

Natural colours: The colour of undyed textile goods prior to dyeing, which needs to be taken into account when formulating the recipe. Sample dyeing is essential.

Natural dyes: Are obtained directly from the various plants and animals, as for instance indigo, cochineal, etc.

Natural dyes: There is a vast number of plants whose extracts can be used for the dyeing of wool, silk cotton and linen; there are also a few examples of dyes of animal origin. Different parts are used depending on the plant, whether the whole plant, the bark, the heartwood, the leaves, the roots or the fruit. For various reasons, e.g. due to the dyeing behaviour, the fastness or the biological availability, only some of these have gained widespread acceptance as dyes. E.g., (a) Cis-bixin (annato) from the seed pods of the fruit of the rocou

tree, for food, oils, margarine, cheese rinds etc. (b) Carminic acid (cochineal) is obtained from the female cochineal insect (*coccus cacti*) and is used as a wool, silk, food and cosmetics dye. (c) Carotene is obtained mainly from carrots, red palm oil and pumpkin seeds, and is used primarily for food and pharmaceutical purposes. (d) Carthamine is obtained at quantities of 0.2–0.3% from flowers of the safflower (*carthamus tinctorius*). (e) Curcumin occurs in the root tubers of the curcuma genus, native to east Asia. (f) Euxanthinic acid is obtained from the urine of cattle which have been fed on the leaves of the mango tree. (g) Fustine and fisetine, obtained from young fustic (tanner's sumac). 1 kg wood dust yields approx. 40 g dye. (h) Haematin from logwood (*campeachy*), the heartwood of *haematozylum campechianum*. It is obtained from 10–12 year-old trees. (i) Hypericin is found in the ratio 1.2–1.5 g/kg in the dried, ground flowers of St John's wort. (j) Indigo is obtained from East Asian *Indigofera* genus and European woad (*isatis tinctoria*) and dyes wool and cotton (principle dye used for jeans). (k) Juglan is found in the ratio approx. 2 g/kg in fresh walnut shells. (l) Kermesic acid is a derivative of anthraquinone, which is obtained from the kermes insect (*kermes ilicis* or *kermes vermilio*). (m) Madder dyes are hydroxyanthrachinones, obtained from the root rind of various plants of the *Rubia* genus, e.g. madder (*rubia tinctorum*). (n) Laccaic acid, consisting of at least 4 components, occurs at 0.5–0.75% in sticklac, the raw material of shellac, which is obtained from the *Coccus laccae* insect. (o) Lawson is obtained from henna and is suitable for the dyeing of wool and silk, and as a hair colour. (p) The example of archil, which is obtained from a slow-growing lichen native to southern lands, shows how excessive use and over-exploitation in the Middle Ages has led to an enduring shortage of the dye plant. (q) Phoenician purple (6,6',-dibromic indigo) is obtained from the shell *Murex brandaris*, or other types, and is used to dye wool and silk. (r) Rutin is contained in the leaves, flowers and fruits of numerous plants, e.g. types of buckwheat and Chinese yellow berries. (s) Saffron is obtained from the stigmas of crocus plants and is used to dye silk as well as a food colouring. Very large quantities of these sources has to be extracted to get even 1 g. of the dyes which makes it very impractical for industrial uses.

Natural fibre: Textile fibrous material of natural polymers of plant, animal and mineral origin. Fibres; Mineral fibres; Natural cellulosic fibres; Natural protein fibres.

Natural gas: Gas obtained from underground deposits and often associated with sources of petroleum. It contains a high proportion of methane (about 85%) and other volatile hydrocarbons (ethane, propane, and butane).

Natural protein fibres: Fibrous materials of animal origin belonging to the overall category of natural fibres. They are subdivided into the following

groups: (a) Wools and hair: sheep's wool (Wool), camel wools (Alpaca; Llama hair; Vicuna; Guanaco), Camel hair; Hare and rabbit fibres; Angora rabbit hair; Goat hairs Mohair; Cashmere; Cashgora; Tibetan cashmere), other hair (Dog hair; Human hair; Cattle hairs; Horse hair, Hog's bristles). (b) Silks: Mulberry silk; Wild silks (Anaphe silk; Eri silk; Fagara silk; Muga silk; Tussah silk; Yamamai silk), other silks (Mussel silk; Spider silk).

Natural textiles: Natural textiles are defined as follows: – Natural textiles: garments made from pure, untreated natural fibres, or those which have been dyed but without chemical treatment. – Natural fibres: fibres of animal or plant origin (wool, silk, natural cellulose fibres, not mineral fibres or regenerated cellulose), preferably cultivated without the use of pesticides. – Untreated natural fibres: neither resin finished nor chemically treated (from antifel to silk weighting). – Natural fibres without finish: unbleached, plant dyed, unadulterated fibre surfaces for skin contact, without the influence of chemicals, resin coating or toxic substances, on the properties of the natural fibre. Lubricants (paraffin lubricants) and sizes (modified potato starch) must be capable of washing out.

Naturell: In Germany and Austria a very light and soft finished, plain woven cotton fabric; used for underwear.

Naught duck: See **Duck**.

Navel: A component of an open-end spinning machine located on the axis of the rotor through which the yarn is withdrawn from the rotor and which modifies the twist of the yarn inside the rotor.

Navajo Blanket: Heavy, stiff wool blanket, woven with geometrical patterns always in straight or zigzag lines in bright colour combination on primitive, upright frame by the Navajo Indian women. It is very closely woven and waterproof. The first specimens were of native wool or unraveled bayeta, the yarn of which was often twisted harder. Later German town yarn and cotton warp was introduced. Most blankets are alike on both sides.

Navajo Ply: Basically a hand-crocheted loop used to create a three-ply yarn.

Navy Twill: Heavy weight, navy blue wool twilled flannel; used for working shirts.

NBS: (1) National Bureau of Standards, Washington, an American textile research body; → Technical and professional organizations. (2) New British Standards.

NBS Unit: See **Colour difference formulae**.

NCH: Standard abbrev. for non-carbonate hardness, permanent hardness.

NE: Dutch Patent.

Neale process: The use of sodium hydrosulphite in combination with sodium boron hydride in vat dyeing.

Near-silk: Trade term for several mercerized cotton linings.

Neat: Combing wool taken from the sides of an average lustre fleece; used for yarns from 32s to 36s.

Neatening: Finishing a cut edge to prevent fraying. Various methods include: turning the edge, pinking overedging, or taping.

Neatness in raw silk: An expression of the degree of freedom of raw silk yarn from loops, nibs, and hairiness as defined.

Neck base girth, in body measurements: The circumference of the neck over the cervicale at the back and at the top of the collar bone at the front.

Necking: (1) The sudden reduction in the diameter of an undrawn manufactured filament when it is stretched. (2) Narrowing in width of a fabric or film when it is stretched.

Neckline: A neckline is an outline or contour of the bodices around the neck or shoulders. It frames the face and directs the eye to or away from the face. A neckline must have an opening or should be large enough to pull through the head. Finishing can be given to the neckline with facing, piping binding and ribbing or with a collar for instance. We have various necklines as jewel, round, 'V' sweet heart etc.

Various Types of Necklines.

Basic/Plain/Jewel: A simple round neckline, which would be faced.

U-Neckline: A deep neckline in the shape of a 'U'.

Scoop: A shallow but wide neckline.

Square: A square neckline, which would be faced with mitred corners.

Horseshoe: A deep horseshoe-shaped neckline, which would be faced.

Built up / Funnel: A high neckline that extends up the neck.

Sweetheart: A feminine, angular, shaped neckline that frames the breasts and neck.

Décolleté: A deep and wide neckline popular in the nineteenth century.

Wide Square: As the name suggests a wide, square shaped neckline that would be faced.

V-Neckline: A faced V-shaped neckline.

Halter: The bodice of a garment is extended round the neck to form straps and a fastening. There is usually only a band of fabric across the back.

Bateau: A wide and shallow neckline that would be faced.

Slashed: A shallow but wide neckline, it is effectively a slit in the garment that is faced.

Sabrina: A wide but shallow neckline that has insets over the shoulder. These may be in a contrast or self-fabric.

One Shoulder: An asymmetrical neckline where the garment is supported by strapping on one shoulder only. The other is bared.

Keyhole: A **jewel neckline** with a slit at the front or the back which is faced and fastened, edge to edge, at the neck with a single button and **rouleau loop**.

Scalloped: A decoratively edged neckline that would be faced.

Inset: A jewel neckline with a slit that has an elasticated insertion.

Racing/ Athletic: The main focus is on the back where the neckline and armholes are cut away to create an 'X' effect. Used in sportswear and casual wear.

Envelope: A wide neckline where the back overlaps over the front and is usually made from a knitted fabric and trimmed with a fine rib.

Crew: A snug-fitting neckline trimmed with a knitted rib as in **tee shirts and sweatshirts**.

Wrap-over Bateau: Similar to the envelope neckline but with a narrower overlap not quite reaching to the sleeve. This example is finished with a knitted rib.

Strapless (Princess Line): A princess line bodice with a band and a notched front but no straps for support.

Off the Shoulder: A feminine neckline where the shoulders are bared revealing the whole neck.

High Cowl: A draped neckline, usually cut on the bias to create more soft folds of draping. This example has a high cowl draping from a funnel or built up type neckline.

Mitred: A square shaped neckline finished with a deep band with mitred corners.

Cowl Inset: See **high cowl**. There is a large inset of fabric, cut on the cross, to allow for soft drapes.

Elasticised: A full neckline that is controlled by elastication.

Drawstring: As the elasticised neckline but here controlled with an adjustable drawstring.

Wide Cowl: See the **high cowl** but here wider and much draped.

Graduated Ruffle: A V-shaped inset of fabric that is trimmed with a pleated and graduated ruffle. The graduation ends at the point of the 'V'.

Sugar Bag: A full neckline that is pulled together with a drawstring or band a few inches down from the edge, this creates a frill effect.

Ruffle Set in Seam: A curved neckline with an inset of fabric outlined with a pleated ruffle

Pleated Ruffle: A V-shaped neckline trimmed by a graduated and pleated frill.

Circular Ruffle: Rather like the Pierrot collar but not as deep.

Necktie: A decorative band of fabric worn around the neck and tied in a knot or a bow.

Needle: (1) A thin, metal device, usually with an eye at one end for inserting the thread, used in sewing to transport the thread. (2) The portion of a knitting machine used for intermeshing the loops. Several types of knitting needles are available. (Also see **Spring needle** and **Latch needle**.) (3) In nonwovens manufacture, a barbed metal device used for punching the web's own fibres vertically through the web.

Needle, in sewing: A thin shaft of drawn steel wire used for sewing pointed at one or both ends with an eye or hook for thread or yarn. The primary stitch-forming device used on all sewing machines to carry thread through a seam. Needles have nine parts including butt, shank, shoulder, blade, groove, scarf, eye, point, and tip. Needles come in a variety of types and sizes depending on the type of sewing machines and the sewing application.

Needle bar, tufting machine: A rigid bar, running the width of the tufting machine in which the tufting needles are mounted at fixed intervals.

Needle Bar: A flat metal plate with slots (tricks) cut into it at regular interval into which needles slide during the knitting process.

Needle bed: Flat metal plate with slots at regular intervals in which the knitting needles slide on the knitting machine.

Needle bonding: Fixing process for Tufted textiles; Needle punched nonwoven fabric, e.g. an alternate insertion and withdrawal of a number of needles in nonwoven fleeces, or similar in the case of napped needle felt fabrics and batt-on-base woven felts.

Needle cooler: A device for blowing a jet of cool air on to the needle while sewing.

Needle cord: A dress fabric, usually of cotton. With very fine cords along the length of the fabric and very short pile. It may be printed or plain, and is hard wearing and usually washable, with one way pile. It is a fine ribbed corduroy.

Needle damage, in sewn fabrics: The partial or complete yarn severance or fibre fusing caused by a needle passing through a fabric during sewing.

Needle feed: The feed mechanism in which the feeding of the material is accomplished or assisted by the needle which moves forward by one stitch while it is through the material.

Needle Felt: See **Punched felt**.

Needle felting, Needle bonding: Fixing process for Tufted textiles; Needle punched nonwoven fabric, e.g. an alternate insertion and withdrawal of a number of needles in nonwoven fleeces, or similar in the case of napped needle felt fabrics and batt-on-base woven felts.

Needle gauge: The distance between needles on a multineedle sewing machine. It is directly connected to the strength of the needle which must bear the stress and strain generated during the various technical cycles of the knitting process. The gauge of the needle is directly proportional to the gauge of the machine.

Needle loom: A machine for bonding a nonwoven web by mechanically orienting fibres through the web. The process is called needling, or needle punching. Barbed needles set into a board punch fibre into the batt and withdraw, leaving the fibres entangled. The needles are spaced in a nonaligned arrangement. By varying the strokes per minute, the advance rate of the batt, the degree of penetration of the needles, and the weight of the batt, a wide range of fabric densities can be made. For additional strength, the fibre web can be needled to a woven, knit, or bonded fabric. Bonding agents may also be used.

Needle loom (Non-Woven): A machine for producing needle felt. A needle beam reciprocates vertically at rates up to 2000 cycles per minute. Felting needles are mounted on a board at a density of 300 to 5000 per metre width and pass through a web or batt which is supported between bed and the stripper plates.

Needle loop: A loop of yarn drawn through a loop made previously. This is the part of the stitch which is composed of loop head and loop leg.

Needle plate: That part of the bed which has openings for needle and feed dog penetrations.

Needle pluck test: A modified burning test for the detection of synthetic fibres spun from the melt (polyamide, polyester) which during the burning test can be drawn out by a needle to form a fine thread following melting, by a heated iron. The needle draw test does not work specifically with polyacrylonitrile, acetate and triacetate.

Needle point: This was originally a type of fine drawn thread work, but it has developed into a craft in which satin stitch and buttonhole stitch are worked over a basic thread.

Needle-point Lace: Laces made with the needle, irrespective of style or design; see bobbin lace.

Needle positioner: A device on a sewing machine which ensures that the needle will stop automatically either in or out of the fabric as required.

Needle punched batting: Textile finishing material that is stabilized but mechanically entangling the fibres.

Needle punched carpets: Textile floor coverings produced by the needling of bonded fibre fleeces (Needle punched felt). May be composed of several different layers (top layer, lining, backing layer). The mechanical needle punching of the nonwoven fabric is known as pre-fixing. In post-fixing, binding agents are used. Nonwoven fabrics with a thermoplastic fibre content are fixed using heat treatment. The fixing needles penetrate the nonwoven fabric either vertically or at a slight angle.

Needle punched nonwoven fabric: Bonded fabrics of the Needle punched felt type and needle punched wadding. Fixed by needling with or without shrinkage or needling with thermoplastic bonding.

Needle punching: The process of converting batts or webs of loose fibres into a coherent nonwoven fabric on a needle loom (q.v.).

Needle set-out: A term that refers to long periods of time when certain needles are removed from the knitting cycle. The process is used to make sweater cuffs.

Needle Size, sewing: Refers to the diameter of the needle measured at the needle eye. Today the most common needle sizing system used around the world is the metric system. The metric number represents the percent of a millimeter. Common needle size application:

Light weight, 60–70

Medium weight, 75–110

Heavy weight, 100–120

Needle slot: A groove that houses a needle in the cylinder or dial of a circular-knitting machine or the needle bed of a flat-bed machine.

Needle specifications, knitting: The typical “European” specifications for a needle includes a word, a number (usually a four digit number) and a final combination of letters and numbers. For example: Vota 78.60 G.02 The capital letter at the beginning of the word (“V”), identifies the origin of the needle (obtained from a wire, pressed or die-cut), the type, the number of butts and the type of tail.

The other capital letters have a very precise meaning, except for the vowels “e” and “a” which are added to make the word pronounceable, and indicate the shape and the height of the butt, the eventual existence of a groove and its size, the length of the tail and some other features of the needle.

The next group of numbers identifies the needle according to the length and the gauge.

The first part (78 in the example) indicates the whole length rounded off to the mm (in our case that makes 78 mm); the second part indicates the gauge of the needle in hundredths of millimetres (in our case the gauge of the needle is equal to 0.60 mm).

The final group of letters and numbers has to be read as follows.

The first capital letter indicates the needle manufacturer (for example Z for Torrington, E for Exeltor, G for Groz-Beckert).

The next number is used to distinguish a specific needle among all the needles produced by the same manufacturer.

The next letter refers to some particular features of the needle: for some needles an “A” indicates that the latch has been fixed with an angular pressed pin while an “R” means that the latch has been fixed with a straight pressed pin.

For other needles, the latch fixing method is indicated by a “0” before the last number.

A “0” indicates that the latch has been fixed with a standard pressed pin; no “0” means that the latch has been fixed with a screw pin.

Needle, knitting: The needle is the basic element of loop formation. There are three most commonly used types of needle: the latch needle, the spring-beard needle and the compound needle. We can divide a needle into three main parts: the hook, which takes and retains the thread to be looped; the hook opening and closing device, which allows the hook to alternatively take a new thread and release the previous one; a system allowing the needle to move and form the loop.

Needle work: All kinds of plain and decorative works (embroidery and lace) executed with the needle by hand.

Needled fabrics: The product of the needle loom (q.v.). Needled fabrics are used for rug pads, papermaker’s felts, padding, linings, etc.

Needling; Needle punching; Needle felting; Needle bonding: The use of barbed needle mounted in a needle loom, to entangle a fibre web or batt by mechanical reorientation of some of the fibres within the structure.

Negative feed: When the yam is pulled off the warp beam by the knitting action of the needles during the loop forming step.

Negrepelisse: French woollen cloth, thoroughly fulled with long raised nap; mostly black.

Negretti: A large species of native Spanish sheep, yields fine and soft wool.

Neo-batik: A technically improved development of Batik. Patterns in molten wax are applied to wellstretched textiles (usually natural silk), and aqueous or alcohol-based dye solutions applied with a cotton wool pad. It is then dried and the wax removed by dissolving in organic solvents, or by ironing between sheets of blotting paper. Then the fabric is steamed to fix the dye. In this way, combinations of wax resistance and different colour schemes can be used to produce unlimited effects.

Nep: A small knot of entangled fibres that usually will not straighten to a parallel position during carding or drafting. Or one or more fibres occurring in a tangled and unorganized mass.

Nephelometer: A device used to measure mainly low turbidity water with results expressed in Nephelometric Turbidity Units (NTU).

Neps: See **Nep**.

Neppy dyeings: Clumps of tangled thin-walled immature cotton fibres (neps) scattered throughout the surface of cotton fabrics, which resist dye uptake and appear as white or pastel-coloured specks on the dyed fabric.

Neri: Grade of waste silk, obtained from the inner smooth skin of the cocoon, left over after the reeling.

Nessler's reagent: Nessler's reagent is used for the detection of ammonia (in water) and for the detection of damaged cellulose (yellow to orange, later grey colouring).

Nessu: Native name in East Africa for nainsook.

Net: A transparent fabric that is neither woven or knitted, but rather the yarns are knotted to form a mesh. Net may be made of cotton, viscose, nylon, polyester or other fibres, according to its ultimate use. Made in varying sizes of mesh and used for curtains and dance dresses, veilings and trimmings. Net can be made by hand or machine in a variety of mesh sizes and weights matched to varying end uses, i.e., veils, curtains, fish nets, and heavy cargo nets.

Net Canvas: Made of cotton or linen with an open texture, in black or white and stiffened with gize; used for embroidery ground.

Net curtain fabrics: Fine, usually transparent fabrics made from suitable yarns. They must be washable and resistant to stretching and ironing; those made from synthetic yarns generally do not require stretching or ironing after washing. There are various different manufacturing methods for net curtain fabrics: looms (fine muslin, voile, etamine, marquissette, Madras), bobbinet machines, a form of bobbin lace machine (bobbinet, tulle and lace curtains), raschel knitting or crocheting machines (raschel or galloon curtains), knotted lacework machines or by hand (lace curtains), and embroidery machines (dotted muslin, burnt-out or air lace).

Net leno: Leno fabrics having the crossing warp (see) floating on the face of the fabric and forming zigzag lines.

Net rate: In a fibre production process the total throughput less waste and inferior or off-grade material.

Net silk: Another name for thrown silk.

Nets: Generally wide-meshed fabrics which are produced by weaving, knitting, crocheting or on raschel looms.

Netting: (1) See **Marquissette**.

(2) In nautics, network made of cord or rope.

(3) The process of knotting threads into meshes that will not ravel.

Nettle cloth: (1) Mentioned in 16th-century English manuscript; is of unknown structure.

(2) A light, sheer fabric, woven of the stem fibres of the nettle in Germany.

Nettle fibres: The nettle class of fibres comprise of Common Nettle (*Urtica dioica*), China Grass (*Urtica nivea*), and Ramie (or rhea). Short, fine stem fibre yielded by the nettle; used for twine, cloth, etc., in Austria, Germany, etc.

Network analysis: A generic term used for several project planning methods, of which the best known are PERT (Programme Evaluation and Review Technique) and CPA (Critical Path Analysis).

Neuilly: French machine-made tapestry made in imitation of the real gobelins.

Neutralization: The stoichiometric reaction of an acid and a base in volumetric analysis. The neutralization point or end point is detected with indicators.

Neutrals, in colouring: Neutrals, or neutral colours, are sometimes referred to as earth tones. Each neutral is a combination of all three primary colours of any percentage mix. Neutrals are often muddy in appearance as they are produced by mixing colours that are opposite on the colour wheel – known as complementary colours – which effectively cancels each other out when

mixed. Theoretically, this cancellation produces non-colour, i.e. black. In reality, because colours are never 100% pure but contain some impurities, the result is not black but a dirty nondescript colour. For instance, a neutral may be produced by mixing complementary colours orange and blue.

Neutron-absorbing fibre: Polyethylene fibre modified with boron used in the nuclear industry for reducing neutron transmission.

New look: Post warwomen's fashion revival from Paris designed by Christian Dior in the forties.

New Zealand Cotton: Fine, strong bast fibre, yielded by the young branches of the ribbon tree in New Zealand; used for fishing lines.

New Zealand Hemp: Long, soft, white, silky and very strong leaf fibre yielded by the Phormium tenax in Australasia; used for ropes, twine, matting and cloths. The base mark is "fair Wellington."

NF: (1) New Zealand flax or hemp (Phormium), (2) Non-ferrous metals. (3) French standard.

Ngutunui: Native name for a species of the New Zealand flax (see) yielding fibres suitable for the finest fabrics.

NI: Indonesian standard.

Nib: See **Nibs**.

Nibs, in raw silk: Small thickened places less than 3mm. in length.

Nickel screens: Are made for rotary printing using the discharge or rotary screen processes. Nickel screens cannot be recycled, i.e. cannot be re-used for other patterns. → Rotary screens for screen printing.

Niddy-Noddy: A traditional, low-tech way to wind a skein and measure yarn. This image of the elusive niddy-noddy shows a very good quality, homemade one. For the less crafty, or to dry damp skeins, consider making one out of 3/4 or 1" pvc.

Nikki-plush: Circular-knit pile fabric (sheared plush). The grey cloth undergoes shearing during finishing, whereby the loops are cut to give a velvety look. The fabric has the elasticity of jersey. Used for outer clothing; also printed. Circular-knit pile fabric finishing.

Nimes: French piece dyed, wool dress fabric of medium quality, originally having 2,200 warp ends.

Ninon: A fabric sometimes called triple voile, which is plain weave and sheer. It usually made of viscose, acetate or sometimes polyester. A sheer, fairly crisp fabric, heavier than chiffon. Much like voile, but more body. The warp

yarns are often grouped in pairs. Washes well, particularly in the synthetics. Uses: Mostly used for curtains, and some for evening or bridal wear.

Nishiki: A very rich gold and silver brocade, made in Japan.

Nip: (1) A defect in yarn consisting of a thin place.

(2) Passage of material (full-width piece goods) between two rollers, in pad dyeing, calendering and similar. The roller nip is the contact line between the two rollers which concentrates the pressure of the two rollers. (3) The gap between two nip rollers (Fig.). There are two types, hard nip rollers, as found in calendars (steel and flexible rollers) and elastic nips between two elastic rollers.

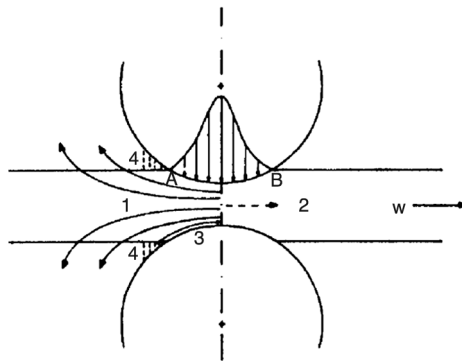

Fig. Diagram showing the squeezing process in the nip. 1 = return flow of liquor; 2 = capillary transportation; 3 = return of liquor to be applied; 4 = liquor wrung out.

Nip creases: Creases occurring at regular intervals along a fabric selvage subsequent to a nipping operation such as calendering or padding. Such creases are caused by a loosely wound selvage or improper let-off tension, which allows the fabric to fold over or gather at the selvage prior to entering the nip of the rolls.

Nip padding: A particular type of padding. With the two-roller pad the lower roller is wrapped with cloth and dips into the padding liquor; the fabric is passed between both rollers. Used especially in resist printing, as the short contact with the liquor prevents the resist from softening.

Nip pressure profile: With the aid of, e.g. carbon paper, impressions can be obtained of the evenness of the squeezing pressure across the full width of the nip.

Nipco rollers: Deflection-free (elastomer) rollers with hydraulic power transmission Pressure generation with even pressure on outer mantle by means

of individual hydraulic supports; load can be applied externally in groups, every 2000 mm, e.g. 5 zones. The Nipco calor roller can be precisely heated from the inside. Used for pads, calendars and other squeezing equipment.

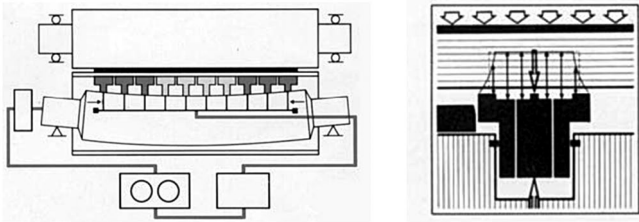

Nipco roller system for the control of an individual pressure stamp (Kleinewefers KTM).

Nitrate discharges: See **Oxidation discharges for indigo ground.**

Nitration: A reaction commonly used in dyes manufacture. Nitration means the introduction of the nitro group, $-\text{NO}_2$, into a molecule. It is accomplished: (a) with dilute or concentrated nitric acid; (b) with mixed acid, i.e., a mixture of nitric and sulfuric acid, sometimes containing some water; (c) by first sulfonating the compound and then nitrating the sulfonic acid, thereby splitting out the sulfo group and replacing it by the nitro group; (d) by oxidizing with dilute nitric acid a previously formed nitroso compound; and (e) by treatment of a diazonium compound with hot, dilute nitric acid, introducing simultaneously a hydroxyl group and a nitro group (e.g., nitroresol from p-toluidine).

Nitrification, in effluent treatment: The two-step biological process in which ammonia is converted to nitrite and then to nitrate.

Nitrification–denitrification: Nitrification followed by denitrification, resulting in bubbling away of nitrogen gas. The process can be undertaken in a wastewater treatment works by having nitrification in the aerobic biological treatment process followed by a denitrifying filter. Alternatively the process can be incorporated into one system with adaptations of the activated sludge process, as in the AAO process, Bardenpho process or the modified Ludzack–Ettinger process where the nitrified wastewater is recycled back to the anoxic tank at the start of the treatment process. Another alternative is the use of a pre-anoxic filter.

Nitrobacteria: Micro-organisms (e.g. bacterium coli commune, typhus bacillus) which oxidise organic nitrogen compounds (ammonia, nitrites, etc.) in the ground, ground water, etc., to nitrates. Nitrobacteria are of significance in connection with the water supply for textile processes.

Nitro Dyes: These dyes are now of only minor commercial importance, but are of interest for their small molecular structures. The early nitro dyes were acid dyes used for dyeing natural animal fibres such as wool and silk. They are nitro derivatives of phenols, e.g., picric acid or naphthols.

Nitro rayon: (Chardonnet rayon), the first man-made fibre (1884 by the Earl of Chardonnet). Produced from Nitrocellulose, using ethanol and ether.

Nitrocellulose: See **Cellulose trinitrate**.

Nitroso dyes: Nitroso dyes are metal-complex derivatives of *o*-nitrosophenols or -naphthols. Tautomerism is possible in the metal-free precursor between the nitrosohydroxy tautomer and the quinoneoxime tautomer.

N-methylol group: See **N-Methylol compounds**.

N-methylolacrylamide: See **Methylolacrylamide**.

N-methylolpolyethyleneureas: A crease-resistant finish; products of the reactions of polyethylene amines or imines, urea and formaldehyde, e.g. from diethylene triamine, urea and formaldehyde:

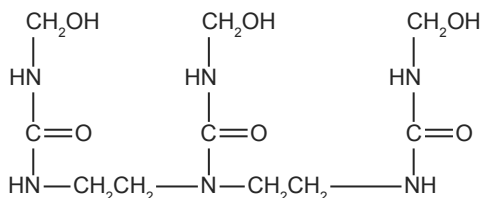

NMMO Process: NMMO stands for N-methyl morpholine oxide, a cyclic amine oxide, in which cellulose is very soluble. The NMMO process is a solvent spinning process in which a Lyocell fibre is produced from cellulose in only a few stages, without the supplementary addition of chemicals. The technique is one of the most ecofriendly process compared with conventional processes which causes of waste water and air emissions and produces much better fibre with comparatively higher dry and wet strength and wet elongation. Moreover, the NMMO solution can be reused.

NOEC (no-effect concentration): When surfactants are biologically degraded, for example, the first stage of the oxidation can be at the hydrophobic end of the chain:

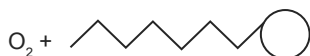

The surfactant loses its effectiveness as a surfaceactive substance, i.e. if during biodegradation the surfactant concentration drops below a certain level, and

it is no longer detectable using the usual tests, and no longer foams or toxic to fish.

No iron: Another term for crease resist finish. The literal expression of the purpose of this finish: no ironing is necessary after the washing process. The most frequently used term is: See **Wash and Wear**.

No-Observed-Effect Concentration (NOEC): Highest constituent concentration at which the measured effect are no different from the control.

Noble Comb: Used commercially in producing worsted yarn.

Node: An English cotton dress fabric having a boucle face and having twisted knots either in the warp or the filling.

Noil: Short fibres removed while combing, applied particularly for wool, but also to other fibres as cotton, silk, rayon etc.

Nomad carpet: Oriental carpets, plush-like, with pile cropped to a greater or lesser extent, warp, weft and knotted sheep or goat wool pile (100,000–300,000 knots per m₂). Mainly narrow pieces (prayer mats, rugs, mats). Design (work of nomads) differs slightly in pattern, width, colour, often distorted and creased.

Nomex: A modified Nylon, poly(p-phynyleneterephthalamide) which is practically flame proof.

Nominal gauge length in tensile testing: (1) The length of a specimen under specified pre-tension measured from nip to nip of the jaws of the holding clamps in their starting position at the beginning of the test, and including any portion of the specimen in contact with bollard or snubbing surfaces.

(2) The length of a specimen under specific pre-tension between frets, in instruments where the specimen is not held by clamps, for example in a vibroscope.

(3) The length of a specimen measured between the points of attachment to the tabs while under specified pre-tension.

Nominal pressure: The maximum permissible Working pressure in bars at 20°C. It is therefore sufficient when denoting the application range of a pipework component (piping, fittings) to give the nominal pressure.

Nominal temperature: The temperature given on measuring instruments at which they should be used. If not given, it is 20°C. If two temperatures are quoted, this means the limits of the temperature range in which the appliance should be used.

Non Battue: Loosely woven French linen canvas of inferior grade.

Noncarbonate hardness: Hardness caused by chlorides, sulphates, and nitrates of calcium and magnesium. Evaporation of waters containing these ions makes the water highly corrosive.

Non-biodegradable: Description of something that is not broken down by microbes and has an *oxygen demand* only if it is a chemical reducing agent. It has no *biochemical oxygen demand*.

Non-conforming: A description of a unit or a group of units that does not meet the unit or group tolerance.

Non-conformity: An occurrence of failing to satisfy the requirements of the applicable specification; a condition that results in a nonconforming item.

Nonpareilles: Camlet like French cloth, made either of all wool or mixed with goats' hair or linen yarn. See also **lamparillas**.

Nonpolar compound: A compound that has molecules with no permanent dipole moment. Examples of nonpolar compounds are hydrogen, tetrachloromethane, and carbon dioxide.

Non-chlorine bleach: Bleaching with chemicals other than one containing chlorine.

Nonelastic woven tape: A woven narrow fabric, weighing less than 15 ounces per square yard, made principally of natural and/or manufactured fibres, including monofilaments, but not containing rubber or other similar elastic stands.

Nonformaldehyde DP finishes: Several countries such as Japan and Germany have even more stringent HCHO requirements than the USA. Because of this, there has been and continues to be interest in non-formaldehyde DP finishes. There are products that fit the description "non-formaldehyde" finishes like Dimethyl-4,5 Dihydroxyethylene Urea (DMeDHU), Butanetetra-carboxylic acid (BTCA) etc.

Nonionic: Those that develop no ionic charge on the water solubilizing end.

Non-Ionic: Descriptive of a chemical that does not ionize in solution, but remains in intact molecular form Some *surfactants* are non-ionic.

Nonionic surfactants: This is the second most important group of surfactants. They are mainly chemicals whose molecules have the usual hydrophobic 'tail' connected to a short polyethylene oxide chain. This will usually have about five to twenty $-\text{CH}_2\text{CH}_2\text{O}-$ units linked together and forms the polar hydrophilic 'head' to whose oxygen atoms water molecules can hydrogen-bond. A wide range of products is available with different types of hydrophobic groups and

varying degrees of polymerization of the polyethylene oxide chain. Some have polypropylene oxide 'heads', usually promoting oil solubility.

Non-lint content: That portion of a mass of cotton fibre which is essentially foreign matter.

Nonmetameric: Shades which are not changing in different lights.

Nonseperable zipper: A zipper having two stringers that are permanently attached to each other at one or both ends.

Non-shrink finish: The finish which prevents shrinking.

Nontorque yarn: See **Textued yarns**.

Non-Wetting agent: The opposite of Wetting agent. A textile-processing agent without specific capillary activity.

Nonwoven blanket: A blanket produced by bonding or interlocking of fibres, or both, accomplished by mechanical, chemical, thermal, or solvent means or a combination thereof.

Nonwoven fabric: An assembly of textile fibres held together by mechanical interlocking in a random web or mat, by fusing of the fibres (in the case of thermoplastic fibres), or by bonding with a cementing medium such as starch, glue, casein, rubber, latex, or one of the cellulose derivatives or synthetic resins. Initially, the fibres may be oriented in one direction or may be deposited in a random manner. This web or sheet of fibres is bonded together by one of the methods described above. Normally, crimped fibres that range in length from 0.75 to 4.5 inches are used. Nonwoven fabrics are used for expendable items such as hospitable sheets, napkins, diapers, wiping cloths, as the base material for coated fabrics, and in a variety of other applications. They can also be used for semi-disposable items and for permanent items such as interlinings.

Nonwoven fabric, Thermally bonded: Textile fabric composed of a web or batt of fibres containing heat sensitive materials, bonded by application of heat with or without pressure. The heat sensitive material may be in the form of fibres, bicomponent fibres or powders.

Nonwoven, wet-laid: Nonwovens of short-staple polymer fibres, produced by spraying from spinning nozzles (polymer solution or melt) onto, e.g. perforated conveyor belt. Used for filter mats, insulation purposes, etc.

Nonwoven pile fabrics: Pile fabric manufactured by the nonwoven fabric manufacturing method.

Nonwovens: See **Non-woven fabric**.

Nonylphenolpolyglycoether: A product of addition of ethylene oxide to nonylphenol.

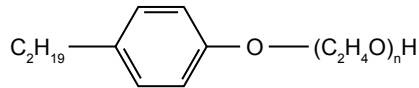

Polyglycol ethers: A washing and wetting agent.

Normal Mixture: Knit goods, made of a mixture of cotton and wool, the colour being black and white mixture.

Normal solutions: Solutions with precisely determined contents for titration. The 1/1 normal solution (1 n solution) contains the Gram equivalent or vol of a chemical substance dissolved in precisely 1 litre distilled water.

Norman Embroidery: Conventional designs filled with crewel wool, parts of the pattern being covered with open fancy embroidery stitches in floss silk.

Normandy Laces: Bobbin laces, made in imitation of Malines and the Chantilly lace.

Normandy Val: Trade name for machine made lace, similar to the shadow lace.

Norsk Tekstilforskningsinstitut: Norwegian textile research organization.

Northamptonshire Lace: English bobbin laces, made in imitation of Lille, Valenciennes and Brussels laces. The mesh ground is very fine.

Norwegian Yarn: Fine, slack-twist yarn, made of Norwegian lambs' wool in natural white, gray or black; used for hand knitting in England.

Norwich crepe: A 19th century English fabric, made of silk warp and worsted filling in colours different from each other or dyed two shades of the same colour. It is woven both sides alike, without a wale and is finished with a gloss; used for women's dresses. In the 17th century, it was an English worsted crepe dyed in black.

Norwich Shawl: A fine English silk shawl, originally made with checks and stripes and embroidered afterwards; later it was made of printed silk yarn.

None: French for knotted.

Notation systems: Ways of graphically representing woven and knitted structures.

Notches: Small cuts made in the edges of garment parts, which are used as guides during garment assembly.

Notions, in quilting: Are items other than fabric or a pattern that are used to complete sewing projects. Common items include quilting pins, needles, thread and chalk.

Nottingham lace: The term is often used to describe a flat, coarse lace used for curtains, bed spreads and table cloths, but Nottingham is the home of the machine-lace industry, so the word is also used to describe any lace made on a Nottingham-type machine.

Nouveaute: French for novelty; fabrics and trimmings outside of the staple lines.

Novaloid: Novaloid is the designation assigned by the FTC for a class of flame retardant fibres made from cross linked phenol-formaldehyde polymer. The fibres of this class in U.S. production are called Kynol and are manufactured by American Kynol, Inc. The fibre is golden yellow in colour and possesses good physical and chemical properties. The fibre is thought to be formed through spinning phenol-formaldehyde prepolymer, followed by heating the fibre in formaldehyde vapour to crosslink the structure. The fibre has low crystallinity with a tenacity of 1.5-2.5 g/d (14-23 g/tex) and an elongation at break of about 35%. The fibre has a specific gravity of 1.25 and a moisture regain of 4%-8%. It is inert to acids and organic solvents but is more susceptible to attack by bases. The fibre is totally heat resistant up to 150°C. It is inherently flame retardant and chars without melting on exposure to a flame.

Novato: A woollen or silk fabric; used in the 16th and 17th century in England.

Novelty Tweed: A description indicating that the cloth is tweed like, but that is one of the conventional tweeds that are easy to recognize. Usually a cloth with some decoration or distinguishing feature.

Novelty yarn: A yarn produced for a special effect. Novelty yarns are usually uneven in size, varied in colour, or modified in appearance by the presence of irregularities deliberately produced during their formation. In singles yarns, the irregularities may be caused by inclusion of knots, loops, curls, slubs, and the like. In plied yarns, the irregularities may be effected by variable delivery of one or more yarn components or by twisting together dissimilar singles yarns. Nub and slub are examples of novelty yarns.

Novoloid fibres: A manufactured fibre containing at least 85% by weight of a crosslinked phenol formaldehyde polymers or novolac i.e. Novoloid is extremely flame resistant and non melting. Its primary use is flame proof protective garmets.

Noyales: (1) Fine French bleached linen, sometimes mixed with cotton; (2) Unbleached, French hemp sailcloth, the strongest .grade made with a six- ply warp.

Nozzle: (1) The spout through which something is discharged, i.e., oil in finish application or fibres in web laying. (2) A term sometimes used to refer to spinnerets. (3) Part of a jet dyeing machine/jet.

NP: Norma Portuguesa Definitiva; Portuguese standard.

NRC: "National Research Council", Canadian textile research organization

NS: Norsk Standard, Norwegian standard.

NSO: Norwegian standards organization.

NTV process: (low-temperature dyeing process). The dyeing of polyamide carpet piece goods on a wind beck at temperatures below boiling point (e.g. 70–80°C).

Nub yarn: An irregular thread containing small spots or nubs, very similar to Slub but the irregularities are definitely nubs.

Nucleation: A process by which crystals are formed. Crystals form initially on minute traces of foreign substances that act as the nucleus, then grow by external addition

Nucleophilic addition: A class of reaction involving the addition of a small molecule to the double bond in an unsaturated organic compound. The initial part of the reaction is attack by a nucleophile and the unsaturated bond must contain an electronegative atom, which creates an electron deficient area in the molecule. Nucleophilic addition is a characteristic reaction of aldehydes and ketones where polarization of the C=O carbonyl causes a positive charge on the carbon. This is the site at which the nucleophile attacks. Addition is often followed by the subsequent elimination of a different small molecule, particularly water. See **condensation reaction**.

Nucleophilic substitution: A reaction involving the substitution of an atom or group of atoms in an organic compound with a nucleophile as the attacking substituent. Since nucleophiles are electron rich species, nucleophilic substitution occurs in compounds in which a strongly electronegative atom or group leads to a dipolar bond. The electron-deficient center can then be attacked by the electron-rich nucleophile causing the electronegative atom or group to be displaced. In general terms:

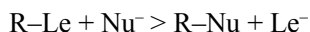

where Nu⁻ represents the incoming nucleophile and Le⁻ represents the LEAVING GROUP. There are two possible mechanisms for nucleophilic substitution. In the S_N1 (substitution, nucleophilic, monomolecular) reaction the molecule first forms a carbonium ion; for example: RCH₂Cl > RCH₂⁺ + Cl⁻

The nucleophile then attaches itself to this carbonium ion: $\text{RCH}_2^+ + \text{OH} \rightarrow \text{RCH}_2\text{OH}$.

In the $\text{S}_{\text{N}}2$ (substitution, nucleophilic, bimolecular) reaction the nucleophile approaches as the other group leaves, forming a transition state in which the carbon has five attached groups. The preferred mechanism depends on several factors: (1) The stability of the intermediate in the $\text{S}_{\text{N}}1$ mechanism. (2) Steric factors affecting the formation of the transition state in the $\text{S}_{\text{N}}2$ mechanism. (3) The solvent in which the reaction occurs: polar solvents will stabilize polar intermediates and so favour the $\text{S}_{\text{N}}1$ mechanism. There is a difference in the two mechanisms in that, for an optically active reactant, the $\text{S}_{\text{N}}1$ mechanism gives a racemic mixture of products, whereas an $\text{S}_{\text{N}}2$ mechanism gives an optically active product (*see* illustration). *See also* **substitution reaction**.

Number duck: *See* **Duck**.

Nun's Cloth: A very thin, plain woven black woollen fabric, similar to bunting; used for mourning wear, for dresses for nuns, office coats, etc.

Nun's Thread: Very fine, bleached linen thread, made by the nuns in Italy and Flanders since the 16th century; used for laces.

Nun's veiling: A fine, lightweight plain-weave, plain coloured, worsted or silk fabric, which is very soft and thin. It is now used for dresses, but was at one time used only for religious gowns. Originally dye only black, brown and grey, but as a dress fabric it is produced in fashion colours. Used for dresses, blouses and nightwear.

Nutria fur: This comes from a small South American animal and is similar to Beaver.

Nutrients, in effluent treatment: Both Nitrogen and Phosphorous, along with carbon are essential nutrients for growth. When discharged to the aquatic environment, these nutrients can lead to the growth of undesired aquatic life. When discharged in excessive amounts on the land, they can also lead to the pollution of ground water.

Nylon: A manufactured fibre in which the fibre forming substance is any long chain synthetic polyamide having recurring amide groups (-NH-CO-) as an integral part of the polymer chain (FTC definition). The two principal nylons are nylon 66, which is polyhexamethylenediamine adipamide, and nylon 6, which is polycaprolactam. Nylon 66 is so designated because each of the raw materials, hexamethylenediamine and adipic acid, contains six carbon atoms. In the manufacture of nylon 66 fibre, these materials are combined, and the resultant monomer is then polymerized. After polymerization, the material is hardened into a translucent ivory-white solid that is cut or broken into

fine chips, flakes, or pellets. This material is melted and extruded through a spinneret while in the molten state to form filaments that solidify quickly as they reach the cooler air. The filaments are then drawn, or stretched, to orient the long molecules from a random arrangement to an orderly one in the direction of the fibre axis. This drawing process gives elasticity and strength to the filaments. Nylon 6 was developed in Germany where the raw material, caprolactam, had been known for some time. It was not until nylon 66 was developed in the United States that work was initiated to convert caprolactam into a fibre. The process for nylon 6 is simpler in some respects than that for nylon 66. Although nylon 6 has a much lower melting point than nylon 66 (a disadvantage for a few applications), it has superior resistance to light degradation and better dye ability, elastic recovery, fatigue resistance, and thermal stability. Two other nylons are: (1) nylon 11, a polyamide made from 11-amino-undecanoic acid; and (2) nylon 610, made from the condensation product of hexamethylenediamine and sebacic acid. Nylon 610 has a lower melting point than nylon 66 and the materials for its manufacture are not as readily available as those for nylon 66. Experimental work has been conducted on other nylons.

CHARACTERISTICS: Although the properties of the nylons described above vary in some respects, they all exhibit excellent strength, flexibility, toughness, elasticity, abrasion resistance, washability, ease of drying, and resistance to attack by insects and microorganisms. **END USES:** Nylon is used for apparel such as stockings, lingerie, dresses, bathing suits, foundation garments, and wash-and-wear linings; for floor coverings; for tire cord and industrial fabrics; and in-home furnishings such as upholstery fabrics.

Nylon 11: See **Nylon**. $\{-\text{NH}-(\text{CH}_2)_{10}\text{CO}\}_n$ Nylon II is produced by self-condensation of 11-aminoundecanoic acid in Europe and marketed under the name Rilsanite. It is melt spun (mp 189°C) into fibre and possesses essentially the same properties as nylon 6 and 6,6. It has high strength (5-7.5 g/d), low specific gravity (1.04), and low water regain (1.2%) and melting point 189°C. Nylon II has excellent electrical properties and is used in electrical products as well as in brush bristles, tire cord, lingerie, and hose.

Nylon 3: See **Nylon**. $(-\text{CH}_2-\text{CH}_2-\text{CO}-\text{NH}-)_n$.

Nylon 4: See **Nylon**. $\{-(\text{CH}_2)_2-\text{CO}-\text{NH}-\}_n$. Nylon 4 is produced by polymerization of pyrrolidone using carbon dioxide catalyst. Nylon 4 is melt spun (melting point 273°C) to give a fibre of about 60% crystallinity. The fibre is of moderate dry strength (4.5 g/d) and slightly higher wet strength, with a higher specific gravity (1.25) than nylon 6 and 6,6. The fibre has excellent elongation and recovery properties and a water regain comparable to cotton (8% at 21°C and 65% RH). Nylon 4 is easily laundered and can be dyed

easily to give colorfast shades but has limited wrinkle recovery properties and is sensitive to hypochlorite bleaches. Although a major attempt was made to commercialize nylon 4, market conditions limited the penetration of this new fibre type and production was discontinued. Nylon 4 is no longer being produced.

Nylon 7: See **Nylon**. $\{-\text{NH}-(\text{CH}_2)_6-\text{CO}-\}_n$.

Nylon 12: See **Nylon**. $\{-\text{NH}-(\text{CH}_2)_{11}-\text{CO}-\}_n$.

Nylon 6,10: See **Nylon**. $\{-\text{NH}-(\text{CH}_2)_6-\text{NH}-\text{CO}-(\text{CH}_2)_8-\text{CO}-\}_n$. Nylon 6,10 is produced by condensation polymerization of hexamethylene diamine and sebacic acid and is melt spun (mp 216°C) into fibres. It resembles nylon 6 and 6,6 in many ways. It is primarily used in brush bristles. Moisture absorption is low at 2.14% at 20°C and 65% Relative Humidity.

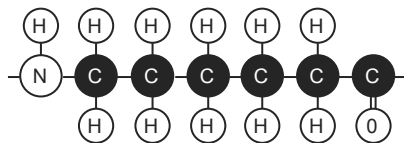

Repeat Unit of Nylon 6

Nylon 66: Polyamides are linear macromolecules containing amide group ($-\text{CO}-\text{NH}-$) at regular intervals. Different types of polyamide are made by using starting material (monomers) of different sizes (different numbers of carbon atoms). Nylon 6 has six carbon in repeating unit and Nylon 66 has two sets of six carbons in repeating unit.

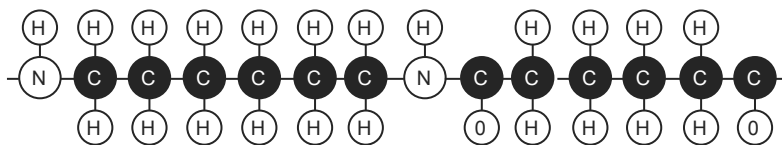

Repeat unit of Nylon 66

Nylon 6T: Modified Nylon. Nylon can be modified in different ways to get different properties including handle, temperature resistance, dyeability, tenacity etc. In Nylon 6T the repeat units are changed i.e., $\{-\text{NH}-(\text{CH}_2)_6-\text{NH}-\text{CO}-\text{C}_6\text{H}_4-\text{CO}-\}_n$. It is a very high heat stable fibre, it melts at 370°C.

Nylon cire: Waxing process applied to light weight plain weave nylon, a very thin shining fabric used for rain coats, anoraks, protective clothing for cyclist etc.

Nylon Dyeing assistants: These are auxiliaries used in the dyebath to assist in getting even dyeing of nylon. These are surfactants which have an anionic group and can be ionized in the dyebath. In nylon dyeing the the ionized acid forms positive group in the fibre ($-\text{NH}_2 + \text{H}^+ \rightarrow \text{NH}_3^+$). Acid dye anion is bound on to this positive sites. The binding force is fairly strong and hence there will be a rushing of the dye as soon as the positive sites are formed can cause an unlevel dyeing. The Nylon dyeing assistants prevents this rushing up by the formation of electrostatic bonds by sulphonate or sulphate groups present in these assistants in competition with the dye anions (R-SO_3^-). Since the dye anion bonding is supported by hydrogen bonds, van de Waals forces etc they are more stable while the leveling agents bonds are slowly replaced by dye anions thereby giving a level dyeing. Usually a surfactant like a fatty alcohol sulphate ($\text{R-O-SO}_3\text{Na}$) like dodecyl benzene sulphonate, Turkey Red Oil or their mixtures can act as a nylon dyeing assistant.

Nylon fibre: See Nylon.

Nylon jersey: Similar to tricot but heavier. A very useful lining or mounting fabric. Although in many other linings, polyester fibre has superseded nylon, this is not the case with nylon jersey. It is hard wearing and has a limited amount of 'give' which will prevent the outer fabric from losing its shape.

Nytril fibre: A manufactured fibre containing at least 85% by weight of a long chain polymer of vinylidene dinitrile [$-\text{CH}_2-\text{C}(\text{CN})_2-$] and having the vinylidene dinitrile group in no less than every other unit in the polymer chain (FTC definition). Nytril fibres have a low softening point so they are most commonly used in articles that do not require pressing such as sweaters and pile fabrics. They are also blended with wool to improve shrink resistance and shape retention.

NZSR: New Zealand Standards Recommendation; the New Zealand standards mark.

O

O and M, operation and maintenance: O and M is a major problem in some countries for water and waste treatment schemes. A lack of finance for spare parts and for labour may exist. The availability or funding to employ technical staff may be absent. Programme schedules for O and M may not exist or not be implemented. In water supply, poor installation and illegal connections can aggravate the difficulties in maintaining the scheme.

Oak leaf braid: A jacquard woven narrow fabric, traditionally 2.4 to 4 cm. (1 to 1 ¾ in.) in width, having a conventional oak leaf and acorn design contained within a border, woven with a cotton warp and either mohair or continuous filament viscose weft. It is customarily used as uniform cap-band.

Oatmeal: See **Oatmeal cloth**. A sort of armure weave, with a resemblance to oatmeal.

Oatmeal cloth: An old fashioned term which was used to describe any fabric, usually wool. That had a coloured, pebbled effect resembling oatmeal.

Oats: Early maturing commercial variety of American cotton, the staple measuring 20–25 millimeters; the yield is 32–34 per cent.

Obermaier loose cotton dyeing machine: This has got a stainless steel cylindrical vessel and another perforated carrier, also cylindrical vessel less than the dia of the outer vessel. The perforated cylindrical carrier has a solid bottom and a perforated central tube which is connected to a seating which fits into the another seat provided at the bottom of the outside vessel which in turn is connected to a centrifugal pump by suitable pipe connections. Cotton is packed into the carrier and lowered in the pouter vessel carrying the liquor. When the pump is run the dye liquor passes through the central tube and into the package and goes out into the vessel through the perforations. After some time the direction of liquor is changed from inside to outside to outside to inside by changing the direction of the pump and the dyeing takes place.

Observer, in colour chemistry: The human viewer who receives a stimulus and experiences a sensation from it. In vision, the stimulus is a visual one and the sensation is an appearance.

Observer, standard: see **Standard observer**.

Ocelot: This is a fairly coarse textured thin fur, but is very hard wearing. Like Leopard, it has spots, but they are more oval in shape.

Octane number: The percentage of isooctane in a blend of isooctane and *n*-heptane that gives the same anti-knock properties as the fuel being tested. Higher octane normally gave increased engine efficiency but modern petrol (gasoline) engines can be highly efficient with lower octane fuels.

Odjaklik: Turkish name for Oriental hearth rugs, usually having a center field with pointed ends.

OE Spinning: A spinning method. The basis of all OE spinning processes is the separation of a fibre tape feed into individual fibres, which are given a twist through various media, and are spun continuously into an “open end” stripping thread.

OE Yarn: See **Rotor spun yarn.**

Oeil de Perdrix: (1) A fancy ground in old French laces, consisting of brides, ornamented with groups of knots; (2) Plain French serge dress goods, made with eight leaves and four picks in a repeat.

Oeillet: French for eyelet.

Off pressing or pressing off: The final pressing operation on a garment after assembly.

Off square, in woven fabric: The difference between the percentage of warp crimp and the percentage of weft crimp.

Off-clip: See **Scalloped selvedge.**

Offset guide: Guide fitted to the exit of a false twist spindle, which causes a deflection in the yarn path, thus assisting the elimination of tight spots from the yarn.

Offset printing: The patterned coloration takes place indirectly via a rubber blanket, with printing colour paste being applied beforehand to the printing plate or roller, from the roller to the rubber blanket, and only then to the material which is to be printed. During the printing process, the printing mould with the non-reversing image passes through the “moistening and dyeing unit”. Through moistening, the non-printing parts become dye-repellent, so that only the printing, water-repellent parts take up the dye paste. This dye paste is “deposited” on a rubber cylinder, which transfers the laterally reversed print image onto the running paper, with slight pressure.

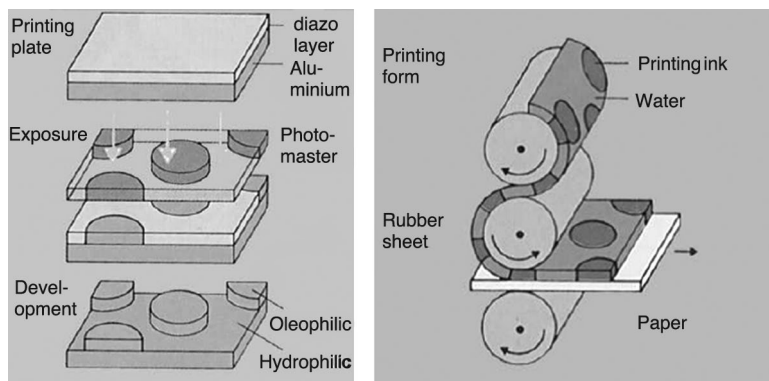

Exposure and development Printing

Off-sorts: The by-products of sorting -- shorts; britch wool, kemp, gray wool, stained wool, etc.

Ogees: Symmetrical onion shapes.

Ogilvie: A Highland tartan of very complicated composition, consisting of wide red and blue stripes, narrower and red stripes and lines of blue, black, red and yellow.

Ohm: Unit of electrical resistance which yields a current strength of 1 A at a voltage of 1 volt; or the resistance of a mercury thread 106.3 cm long and a cross-section of 1 mm^2 at 0°C . The resistance is in direct proportion to the length, and in inverse proportion to the cross-section of a conductor. Resistance in ohms = length (m) multiplied by specific resistance in ohms (resistance of a substance of 1 m in length and 1 mm^2 cross-section) divided by the cross-section (mm^2).

Oil circulation heating: (Circulating hot oil unit). In order to obtain a greater evenness of temperature in the stenter frame, one can heat with hot oil, circulated by a pump, which has a flow temperature of around $40\text{--}50^\circ\text{C}$ higher than the target temperature in the stenter frame, through separate heating, i.e. where the frame temperature is 190°C , the oil temperature is approx. 240°C . Independent of boiler room.

Oil cloth: A cotton fabric that has been treated on one side with a drying oil to make it impervious to water. Usually Linseed oil varnish is used. It is mainly used as a table or shelf covering, before laminated plastic appeared. Also used for bags and raincoats. These type of cloth has been completely superseded by modern coated clothings.

Oil Emulsion: Emulsion system of water-in-oil (W/O).

Oil Finish: Finish with an oily, greasy handle, e.g. for anoraks. Originally, a non-permanent coating with vegetable oils. Permanent effects were only achieved through padding with Silicone elastomers.

Oil of Vitriol: Sulphuric acid.

Oilproof: A term describing fabrics that are impervious to oil.

Oil repellence of textiles: This is the capacity to withstand wetting and penetration by oily liquids. Oil is not absorbed, but is repelled in droplets. The effect is achieved by the application of oil-repellents in the oleophobic or oil-repellent finish. It is brought about by the fact that the forces acting between the oil-repellents and the oil droplet are weak in comparison with the forces acting within a drop of oil.

Oil repellency: Oil Repellency is tested by placing a drop of oil on the fabric and observing whether the drop resides on top the fabric or whether it penetrates. A homologous series of hydrocarbons decreasing in surface tension is used to rate the fabric's oil repellency. The hydrocarbon with the lowest surface tension to remain on top and not penetrate is indicative of the fabric's repellency; the lower the surface tension of the liquid, the better the fabric's resistance to oily stains.

Oil repellent: A term applied to fabrics that have been treated with finishes to make them resistant to oil stains.

Oil repellent finish: The textile auxiliaries used for Water-repellent finishing are not sufficient to protect textiles against grease and oil stains. For this, special products are used, e.g. Fluorocarbon polymers, which are used in the form of emulsion, sometimes in padding, sometimes in the exhaustion method. However, these products in turn do not provide a good water-repellent effect, which is why in practice oil repellents and water-repellents are always used together. Some of the products available on the market provide effects which are resistant to washing and dry cleaning. Used with the Soil release finish.

Oil separator: A tank which separates oil from water or wastewater, such as an API separator, flotation tank, grease trap, inclined plate and tube settlers, oil coalescer, oil grit separator.

Oiled silk: (insulating silk). Transparent, impregnated and printed fabric for raincoats, umbrellas, swimsuits, furnishing fabrics, etc. Manufactured according to a special process, such as elasticised urea resins. To avoid surface sticking, it is recommended that less elasticized urea resins are included, and that the mixture is thinned with alcohols or glycol ethers to immersion consistency. Usually dried at 80°C; this can also be accelerated by the addition of weak acids.

Oil emulsion: Emulsion system of water-in-oil (W/O).

Oil finish: Finish with an oily, greasy handle, e.g. for anoraks. Originally, a non-permanent coating with vegetable oils. Permanent effects were only achieved through padding with Silicone elastomers.

Oil-hydraulic batching drive: Flexible drive for all winding operations with hydraulic motors, which guarantee the constant goods tensions for each winding size.

Oil-in-water emulsion: See **Aqueous emulsion**.

Oil repellence: This is the capacity to withstand wetting and penetration by oily liquids. Oil is not absorbed, but is repelled in droplets. The effect is achieved by the application of oil-repellents in the oleophobic or oil-repellent finish. It is brought about by the fact that the forces acting between the oil-repellents and the oil droplet are weak in comparison with the forces acting within a drop of oil.

Oil-repellent: See **Oil-repellent finishing**.

Oil-repellent finishing: The textile auxiliaries used for Water-repellent finishing are not sufficient to protect textiles against grease and oil stains. For this, special products are used, e.g. Fluorocarbon polymers, which are used in the form of emulsion, sometimes in padding, sometimes in the exhaustion method. However, these products in turn do not provide a good water-repellent effect, which is why in practice oil repellents and water-repellents are always used together. Some of the products available on the market provide effects which are resistant to washing and dry cleaning. Used with the Soil release finish.

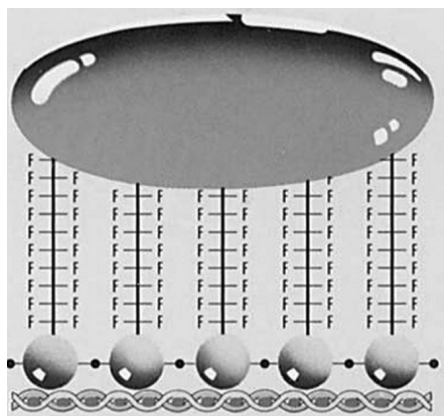

Principlr of oil repellent finish

Oiling: The oiling process aims at minimising resistance during the various operations that transform staple into yarn (e.g. Preparation process for the willowing, carding and spinning of wool fibres or cellulose flocks or blends. Purpose: Increasing sliding properties through Textile lubricants with a film-forming characteristic which ensures an effective protective shell, lowers friction, and encourages stretching ability, flexibility, mouldability, etc. In the case of cellulose, there is in addition the elimination of electrostatic charges) and then yarn into fabric (e.g. for the purpose of better processing in knitting-hosiery, warp knit and weft knit fabrics). Operating conditions: staple is sprayed with oil emulsions in water stabilised with surfactants (favouring the subsequent elimination).

Oilskin: Fabric of any natural or synthetic fibre that has been treated with linseed oil varnish. Used for protective clothing but is obsolete now.

Okinawa Jyofu: Fine and lightweight dress goods made of the leaf fibres of the banana tree in Japan; used for summer dresses.

Okra: (1) White, very light but brittle and not very strong fibre yielded by a species of hibiscus in India, the West Indians, etc.; used for ropes, cordage, etc; (2) Commercial variety of early maturing American cotton, the staple measuring 24-26 millimeters, forming small bolls; the yield is 30-32 percent.

Olala: Native Hawaiian name for the young leaves of a sedge, dried and bleached and used for fine mats.

Olanes: Printed cotton cloth in Cuba with small, usually dark red designs over a white foundation.

Olefin: Generic name for fibres derived from polyethylene or polypropylene. It is resistant to weather, mildew and chemicals, making it useful in rugs, upholstery and furnishings. It is lustrous dyes well and hard wearing.

Olefin Fibre: A manufactured fibre in which the fibre forming substance is any long chain synthetic polymer composed of quantity least 85 % by weight of ethylene, propylene or other olefin units except amorphous polyolefin qualifying under rubber. See **Rubber**.

Olefin sulphonates: a-Olefin Sulphonates are produced by reacting linear a-olefins (usually in the C_n-C range) with SO₃ and air to give mainly 2,3-alkenesulfonic acid and 1,3-sultone. Subsequent alkaline hydrolysis converts the sultones to alkene sulphonates and hydroxyalkane sulphonate. A typical product ratio is 7:3:1 alkene sulphonate/hydroxyalkane sulphonate/disulphonate. Low levels of vinylidene sulphonates are also present. Compounds with an alkyl chain length in the range below #14 are used in

liquid detergents, while those above *C14* are used in spray-dried powders. The hydroxy group gives the product mixture enhanced water solubility, but the double bond makes the mixture unstable to bleach. α -Olefin sulphonates are less sensitive to water hardness than most anionics and are readily biodegradable.

Olefin (polyolefin/polypropylene): A manufactured fibre characterized by its light weight, high strength, and abrasion resistance. Olefin is also good at transporting moisture, creating a wicking action. End-uses include active wear apparel, rope, indoor-outdoor carpets, lawn furniture, and upholstery.

Oleic acid (Olein, $C_{17}H_{35}-COOH$): One of the main raw material for the manufacture of soap. It is formed as a by-product of the manufacture of stearic acid. It is a colourless (pure state) to yellowish-brownish oil (unsaturated fatty acids; odourless; solidifies at 4°C, melts at 14°C; water insoluble; forms easily soluble alkali salts to form Soap. Uses: soap manufacture, lubricants for wool (absence of mineral oil, stearin, and similar substances, which are difficult or impossible to saponify).

Olein acid: Oleic acid.

Olein soap: Soap. Olein with special emulsifiers (mostly OE addition compounds), possibly with corrosion- preventing additives. With water, directly yields finely dispersed working emulsions.

Oleophilic: A term describing a substance that has a strong affinity for oils. Opposite of Oil repellent (oleophobic). Some synthetic fibres, as well as cellulose and cotton which have been given a noniron/ crease-proof finish with synthetic resins, are strongly oleophilic, but also Water-repellent (hydrophobic). Such materials are therefore easy to soil with oil, but difficult to wash with an aqueous liquor.

Oleophobic: A term describing a substance that does not have a strong affinity for oils.

Oligofilament: Term used to describe a filament consisting of a few (2–16) continuous chemical fibres.

Oligomer: A polymer molecule consisting of only a few monomer units. (Greek: oligos = few, meros = part), few duplicated parts. Low-molecular attendants in High polymers. Can be thought of as by-products not preventable by reaction kinetics (Pleionomers) in the synthesis of fibre polymers. Can be extracted using organic solvents. The structure is linear and cyclical.

Oligosaccharide: A carbohydrate formed of a small number of monosaccharide units (up to around 20). See **Sugar**.

Olive Oil: Olive oil contains 82% oleic acid and 8% linoleic acid. It is virtually pure triolein. It is a high grade salad oil, remaining liquid when refrigerated. It is also highly prized as a cooking oil.

Olona: Very strong and durable bast fibre yielded by a species of the nettle (*Touchardia latifolia*) in Hawaii; used for fishing nets, cords and lines.

Omb, Omg, Omf: See **owf, owb, owb**, respectively; the 'm' stands for 'mass', which is preferred to 'weight' in modern scientific language.

Ombré: The French word for 'shadow' used to describe any fabric in which the colour fades gradually from light to dark; sometimes a stripe effect is achieved, sometimes an attractive all-over shading. Fabric printed in this way may be of any type of fibre.

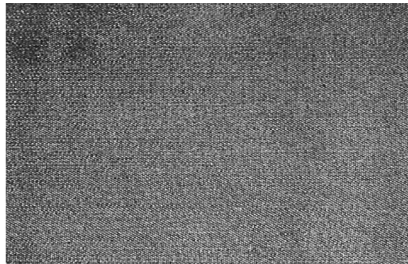

Ombre printing: Printing with shaded effect. The effect is usually brought by the technique in engraving very effectively done by laser engraving, manual engraving is less effective.

On-all cotton: Raw cotton purchased under a procedure whereby the price, (Points on or off futures) as agreed between buyer as setter, but the actual futures price is left to be fixed within a stipulated period. The buyer has the right to 'call' any time within the stipulated period.

Onde: (1) A French word meaning waved, used in relation to textile fabric to describe a wave effect produced by calendaring or weaving. (2) A light French woollen dress goods; (3) French term for moire effect on silk and wool fabrics.

Ondee: Yarn made of a fine and a heavier strand.

Ondine: A thick, cord bengaline in which every cord is crinkled.

Ondule: This fabric is of similar appearance as in Ombre, i.e. wavy effecting the warp direction, also of French derivation but is produced by groups of warp threads being forced from side to side using an nodule reed that moves up and down during the weaving of a series of picks. The material is often used in curtains and furnishing fabrics.

Ondule' reed: A special reed that has a group of dented or spaced wider at the top and closed at the base and vice versa alternatively used to produce an Ondule' fabric.

O'Neill's H3 Series, Comm. Emt Jacket: Global sportswear company O'Neill is a major brand in the manufacturing of products for wakeboarding, surfing, snowboarding, etc. They have developed the Comm. Emt jacket for snowboarding, using ElekTex's technology. Techniques used by O'Neill are based on ElekTex's techniques, but the Comm. Emt jacket has big, special feathers, which are warm, waterproof, and also maintain the music player and cell phone in many environments like wakeboarding, surfing, snowboarding, etc. These factors show that music player clothes have to develop further to maintain ability not only in everyday life but also under various circumstances.

Onium dye: Cationic dye, in which the central atom effects one atom bond more than corresponds to the number of its valency electrons. The relevant anion is connected to the cationic complex via an ion bond.

Onium compounds: (cation-active compounds), definition as Complex compounds, in which the central atom effects one atom bond more than corresponds to the number of its valency electrons. Since, in onium compounds, the cation represents the active constituent, the onium compounds used in textile finishing are termed cation active (auxiliaries).

On-line: An ERP system in which the data input and output terminals and the central computer which processes the data are directly connected. The output data can be seen online.

On-line controller: A controller which checks and controls all the parameters on continuous runs of material. These include e.g. synchronous controllers, loop and tension controllers and band thickness controllers.

On-line quality control: In a manufacturing process, on-line testing of the goods currently in production is used in order to prevent non-permitted variations in quality being produced at a production location (e.g. colour). On-line testing is thus an early warning system within quality assurance, to prevent "freak values". The online testing can be inter connected to automatic adjustments of the parameters on the machine to get better consecutive results (e.g. moisture content after padding, GSM of fabric in compacting, online pH control etc.

ÖNORM: Austrian standard.

On-stream: The state of having been brought into production. The term is usually used for chemical and metallurgical plants or processes.

Onteora Rug: American rug woven on hand looms. The weft consists of piece ends of coloured denims, forming blocks, stripes and arrows as designs.

Opal batiste: Fine-filament, milky-looking cotton batiste, named after the semi-precious stone opal. Simple cotton yarns, usually maco yarns, are used for this. Finish: pre-mercerising, bleaching, acid treatment and final mercerising without tension. This creates a shrink effect which lends the fabric its milky appearance. Opal comes dyed, printed and embroidered in delicate colours, as well as in white. Used for summer clothing fabric, decorative aprons and in the cleaning industry.

Opaque finish: (1) In the case of thin knits, reduced transparency is often desirable, and this can be achieved through a calendar process. (2) Black-out curtains are intended to prevent any light entering; this is achieved by coating.

Open area (printing screen): See **Printing area**.

Open box washer: Washing machine in which the washing compartments are open.

Open Band: Yarn twisted to the right hand.

Open decatizing: See **Decatizing**.

Open end spinning: The production of spun yarns by a process in which the sliver (q.v.) or roving (q.v.) is opened or separated into its individual fibres or tufts and is subsequently reassembled in the spinning element into a yarn. (See also spinning). This system of spinning is based on the concept of introducing twist into the yarn without package rotation by simply rotating the yarn end at a gap or break in the flow of the fibres between the delivery system and the yarn package. Because the twisting element can be compact and the mass of material to be rotated is small, very high twisting speeds can be attained. The process, in a sense combines the traditional processes of roving and spinning in one operation. Present work is directed toward incorporating the drafting operation into the process by using card sliver as the feedstock. This can facilitate process linking.

Open face: A fabric defect consisting of an open appearance of the fabric which permits the filling to “grin” through the warp ends in the center portion of the fabric.

Open lace: See **Darned lace**.

Open lap: Is produced either when a subsequent underlap is in the same direction as the preceding overlap or an underlap is omitted so that the overlap of the next knitting cycle commences in the needle space where the previous overlap finished.

Open place: See **Crack mark**.

Open place: See **Crack**.

Open-shoulder construction: A method used on better coats that is characterized by hand-sewn lining shoulder seams.

Open width Centrifuge: Centrifuges for piece goods in their open-width state, also for warp- and weft tie beams.

Open width dyeing machines: These systems are used for dyeing open-width and well-flattened fabrics. These systems can be used also for carrying out pre-dyeing treatments (for example upgrading, bleaching, mercerising), dyeing treatments and wetting operations for both types of treatment. Among the systems used for open-width treatments it is worth pointing out mercerizing machines, jiggers, pad dyeing machines, beam dyeing machines, continuous washing systems, stenters.

Open width processing: The treatment of fabric at its full width in the unfolded state in contrast to rope form processing. It may be carried on rollers through the processing media or be held on a roll as in beam dyeing or cold pad batch.

Open width washers: An open width washer can be a simple box containing a series of vertically stacked rollers where the lower rollers are submerged in the wash water. Fabric enters the box at one end and traverses the box by going over and under each stack. Any number of these boxes can be arranged in series to provide the appropriate amount of rinsing. More sophisticated boxes will be divided into several compartments. Squeeze rolls are placed between them to speed up the removal of impurities. Some are equipped with spray nozzles which also facilitate the flushing action. There are other type designs also.

Open-width dyeing machines: These systems are used for dyeing open-width and well-flattened fabrics. These systems can be used also for carrying out pre-dyeing treatments (for example upgrading, bleaching, mercerising), dyeing treatments and wetting operations for both types of treatment. Among the systems used for open-width treatments it is worth pointing out mercerizing machines, jiggers, pad dyeing machines, beam dyeing machines, continuous washing systems, stenters.

Open Work Fabrics: Are fabrics like lace and net which can be made by different techniques like leno, bobbinet or warp knitting etc.

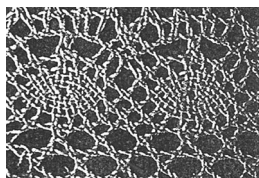

Open Wool: Wool that is not dense on the sheep and shows a distinct part down the ridge or middle of the back. Usually found in the coarser wool breeds.

Opening: The second step in commercial wool processing (after sorting). The purpose is to open up the fleece in order that scouring will be more effective.

Openness value (OV), in fibre mixing: The openness value (OV) is a measure of how ‘fluffed up’ the fibre mass has become on passing through a beater system, i.e., the effectiveness of the degree of opening. Since we are concerned with changes in tuft density, and to take account of different fibre densities, OV is defined as the product of the specific volume of the fibre mass and the specific gravity (SG) of the constituent fibres (or for a blend of fibres the sum of the product of their relative proportions and their SGs).

Openwork: In embroidery, laces, knitting and crocheting interstices in a ground of closer texture, often to form or enhance a pattern.

Opening: (1) A preliminary operation in the processing of staple fibre. Opening separates the compressed masses of staple into loose tufts and removes the heavier impurities. (2) An operation in the processing of tow that substantially increases the bulk of the tow by separating the filaments and deregistering the crimp.

Open lap: If the overlap and the next underlap are made in the same direction, an open lap is produced.

Openness, in garments: The provision for leg stance in the angle of the leg seams.

Opera flannel: A narrow and very smoothly finished lightweight wool flannel, usually dyed in light colours; used for women’s and children’s garments.

Oporto: Coarse Portuguese wool; used for carpets.

Optical brightener: A fluorescent dye used to make white textiles appear brighter; often called just “optical” in dye industry; also called fluorescent brighteners or fluorescent brightening agents (FBA) Optical brighteners are colorless dyes that work by emitting visible light, typically in bluish hue, when exposed to invisible ultraviolet light. This bluish tint helps mask the residual yellowish cast of bleached cellulosic fibres and wool, making the fabric appear a more neutral white. These are “colour substances” which absorb light in the ultra-violet range and emit it again in the visible range. They therefore bring about an optical illusion on textiles, in that they raise the level of whiteness of the goods. This characteristic is associated with their chemical structure, as follows: Cellulose fibre brighteners are derivatives of diamino stilbene di-

sulfonic acid. The speciality of this product is that it has trans-configuration, since only this form has a planar π -electron system enabling mesomerism in the excited state:

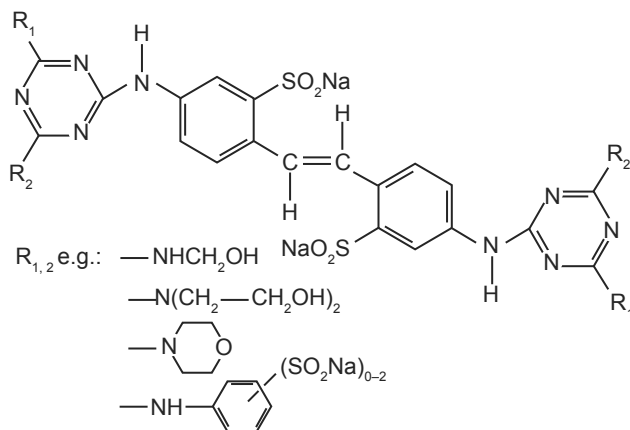

Most fully-bleached commercial white fabrics have been treated with these brighteners. Fabrics and garments that are truly prepared for dyeing should not contain brighteners. Optical brighteners can interfere with some dyes by competing for the “dye sites” on the fibres. It is almost impossible to remove brighteners once they are applied. Most commercial laundry detergents contain optical brighteners, which is primarily the reason that they are not the best choice for scouring fabric prior to dyeing. When detergent containing optical brighteners is used to wash brightener-free fabric that has been dyed to pale shades, noticeable shade change may occur.

Optical brightening: The process of applying optical brightening agent on fibre, fabric or any other material.

Optical fibre: Cladded core fibre made of inorganic or organic glass, whose core (diameter 5–100 μ m) has a higher refractive index than the sheath. Through total reflection, light which enters at one end of the fibre and emerges at the other end transferred with as little loss as possible. Used for information transfer, lighting engineering, etc.

Optical finishes: Lustre may be imparted to a fabric by physical means. The techniques basically involve flattening or smoothing of the surface yarns using pressure. Beating of the fabric surface or passing the fabric between hard calendaring rolls under pressure and with some friction will tend to flatten out the yarns and lower light scattering by the fabric surface, thereby improving reflectance and lustre. Lustre may be improved further if the calendaring rolls

are scribed with closely spaced lines which will be imprinted on the fabric to reinforce light striking and reflecting from the fibre surface. Similar techniques can be used to impart optical light interference patterns to the fabric (moiré'). Thermoplastic fibres which can deform under heat and pressure can most readily be modified to impart lustre.

Optical properties: A general term used to refer to the relations of yarn or fibres with light. It includes such parameters as birefringence, refractive index, reflectance, optical density, etc.

Optimization: The organisation of technical and economic systems or processes in order to achieve a given aim in the best possible way, taking into account all secondary conditions. The optimization of finishing processes must be the aim in every firm. Process control through measuring and control equipment represents the means for this.

Optimum twist: In spun yarns, a term to describe the amount of twist that gives the maximum breaking strength or the maximum bulk at strength levels acceptable for weaving or knitting.

Opus Anglicum: Medieval Latin name for embroidery made in England by chain stitch worked in circular lines.

Opus Araneum: Medieval name for a coarse darned netting.

Opus Consutum: Medieval Latin name for applique.

Opus Filatorum: Medieval name for darning embroidery on a square mesh foundation.

Opus Pectineum: Medieval Latin term for a brocaded silk fabric woven on hand looms with the aid of a comb-like instrument.

Opus Plumarium: Medieval Latin name for embroidery in feather stitch.

Opus Pulvinarium: Medieval Latin name for embroidery made on open canvas ground with silk or wool in cross stitch.

Opus Saracenicum: Medieval Latin term for tapestry.

Opus Scissum: Latin name for the first cut work.

Opus Tiratum: Latin name for drawn work.

Orange peel effect: Local shrinkages in two-layered fabrics such as e.g. synthetic leather; occurs particularly when non-woven fabrics are used as carriers. The cause is likely to be an uneven fibre distribution in the non-woven fabric.

Orbis printing: (Tschekonin method). Patterning by means of a semi-solid coloured (mosaically composed) gelatine mass which has been applied to a

metal roller, and which is produced beforehand and cut out in accordance with the pattern. Printing takes place with this, until the printing mass has been used up (i.e. similar to Offset printing). A new roller can then be produced in the same way. Strong prints are produced by this method.

Orchil: Violet dyestuff, used for animal fibres, obtained from a lichen (*rocella tinctoria*).

Orenburg Shawl: A framework knitted fabric, made by shifting certain loops sideways the distance of several needles and thus forming the design.

Orifice: Hole in end of flyer, directing the yarn to the bobbin, may also be a hook or pig's tail.

Organdie: The sheerest cotton fabric made of very fine 100% cotton yarn. Its crisp finish is due to the application of a sulphuric acid process. Organdie creases very easily and used in small areas such as collars, cuffs, bows sashes and cumbernunds, and in India as Sarees. It can be used as an interfacing fabric in lightweight garments and also as a mounting material. It is sometimes used for hats.



Organdy or Organza: (silk) Warp and weft non-degummed Organzine yarn woven in a lattice structure. A light very transparent fabric characterized by a rather stiff handle (Organza is a registered trade mark).

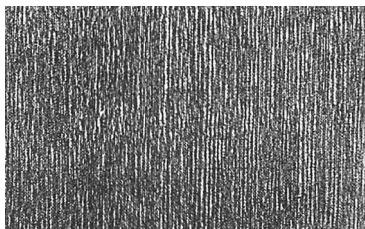

Organdy: It is a light weight, sheer, stiff, transparent plain weave cloth of typical construction 82×74 with 80s warp and 100s weft. Sometimes finer yarn counts are also used. Yarns are combed and are even mercerized.

Organdy is always stiff. The stiff crisp finish is obtained either by treatment of the cloth with sulphuric acid at certain concentration or by other permanent, semi-permanent or temporary finishes.

Organdy finish: See **Transparent and opal finishes.**

Organic: In this glossary, this term carries the chemist's meaning: a chemical that is derived from carbon and hydrogen. It does not imply that the chemical had a biological origin, or that it is not dangerous.

Organoliths: They are mainly organic ion exchangers and is mainly divided into two groups. (1) Artificial organoliths (carbon exchangers): sulphonated high molecular humus coals (brown coal, peat, wood), as acid-resistant ion exchangers. (2) Synthetic organoliths (exchanger resins, synthetic resin exchangers, resin exchangers): porous condensation and polymerisation synthetic resins with a large inner surface, with numerous reaction-capable, ionforming acid or basic groups. (a) Cation exchangers are, e.g. condensation products of aromatic basic bodies of an acid nature, such as mono-valent or poly-valent phenols, aromatic and aliphatic sulphonic or carboxylic acids, with aldehydes, sulphonated phenol resin, sulphonated styrene, carboxylic acid resin, oxysulphonic acid resin, etc.; e.g. (in 3-dimensional terms):

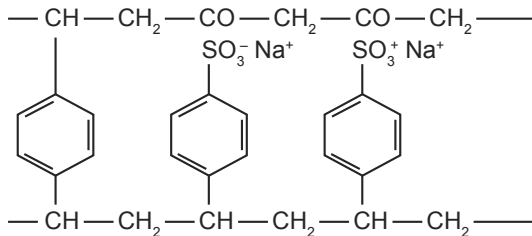

(b) Anionic exchangers are, e.g., condensation products of aromatic and aliphatic amines with aldehydes and related compounds of quaternary polyamines, etc.; e.g. (in 3-dimensional terms):

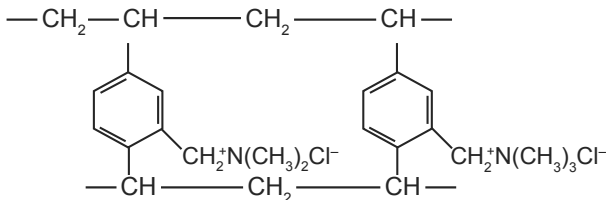

In textile these are mainly used in infeed water treatments, demineralisation (e.g boiler feed water and even in effluent treatment plants).

Organopolysiloxanes: Organic silicon compounds of an oily or resin-like condition. Used for water-impermeable finishes.

Organosiloxanes (organopolysiloxanes): See **Silicones**.

Organza: Similar in appearance to Organdy (Organdy), but made from silk viscose or polyester fibre. It is fine stiff and wiry and creases very easily. Used for evening wear and trimming and may also be used as interfacing in fine fabrics.

Organzine: Silk yarn from two or more twisted greige threads single yarns are given a preliminary twists and two or more are doubled and twisted again in the reverse direction. The preliminary twist consists of 600-700 and the subsequent one 500-600 twists per metre. Organzine yarn has a stiff handle and produces a tightly closed effect. In the boiled off state a soft lustre is produced. It is a preferred yarn for warp for plain and coloured woven fabrics, but is also used for knits, which have recently made increasing headway in to fashion collections.

Organzine yarn: See **Yarn, Silk**.

Oriental carpets: Hand-made carpets of Asia, especially Asiatic Turkey, Persia, Bokhara, Afghanistan and India. They have either hand-knotted pile or are woven similar to tapestry. The material is usually wool, but the finest Persians have silk pile. The design is characteristic of each district and good examples of carpets show beautiful rich and finely blended colours. Genuine, tightly-woven plush carpets, originating from the Orient: usually hand-knotted (typical Knot density), always knotted through (each individual knot and each pattern discernable on the reverse), irregular pattern, often not quite uniform colour (slightly stripey in the background), fringed edge formed of warp threads. Main groups: Smyrna carpets; Persian carpets; Nomad carpet. Dyeing: previously with vegetable dye (usually good fastness to light, frequently not sufficiently fast to water and washing); European imitations of Oriental carpets are more resistant to washing and cleaning.

Orientele: Single faced, ribbed, French silk dress goods with a high finish, made with ply warp. There are 18 warp ends and 18 picks in a repeat.

Orientation: a) The degree of parallelism of fibres, usually as a result of a combing or attenuating action on fibre assemblies that causes the fibres to be substantially parallel to the main axis of the web (q.v.) or strand. b) A preferred direction of linear molecules in the fine structure of fibres and usually caused by so stretching an extruded fibre that the length direction of the molecules tends to lie parallel to the main axis of the fibre. c) In the case of natural fibres, a preferred direction of linear molecules laid down during growth, e.g. a spiral around the fibre axis in cotton.

Orientation, in Button: The degree of order and spatial alignment of pearlescent pigments to the button resin formulation or to the formulation used for coating.

Orifice: Generally, an opening. Used specifically to refer to the small holes in spinnerets through which the polymer flows in the manufacture of fibres.

Original twist: The twist in a single or plied yarn component of a plied or cabled yarn as the component was before incorporation into the more complex structure. See also **Twist, Original**.

Orleantine: (1) French serge dress goods, made with 10 leaves and 10 picks in a repeat; (2) French dress goods made with two-ply warp, having eight leaves and six picks in a repeat.

Orlon: One of the first acrylic fibres made by du Pont. It melts at high heat, but does not catch fire. It is warm and absorbent, blends very well with wool and other fibres, and is used extensively in knitwear and dress fabrics.

Ormuk: A fine, soft fabric, made of the hair of young camels in Turkestan.

Ornamental stitches: The ornamental stitches most frequently used are (a) outline, (b) chain, (c) cat or herringbone, (d) blanket or loop, (e) feather, coral or briar, (f) hemstitching, (g) French knots, (h) button hole, and (i) cross stitch. Excepting the cross stitch, these are all variations of the plain and button hole stitches.

Orraye: Heavy and closely woven silk satin of Persian origin with embroidered flowers; it is made alike on both sides.

Orsey Silk: Same as organzine.

Ortho: A chemical prefix, usually abbreviated *o*, signifying that two substituents appear in adjacent positions on a benzene ring.

Orthopedic and surgical felt: A white, soft, low density, highly resilient felt.

Ortigao: Strong bast fibre, yielded by a species of the nettle in Brazil; used for nets, clothing, etc., by the natives

Ortigue: A coarse French packing canvas.

Osman: A very firm terry cloth made in England, the loops being beaten up on four picks.

Osmotic pressure: Symbol: π The pressure that must be exerted on a solution to prevent the passage of solvent molecules into it when the solvent and solution are separated by a semipermeable membrane. The osmotic pressure is therefore the pressure required to maintain equilibrium between the passage of solvent molecules through the membrane in either direction and thus prevent

the process of osmosis proceeding. The osmotic pressure can be measured by placing the solution, contained in a small perforated thimble covered by a semipermeable membrane and fitted with a length of glass tubing, in a beaker of the pure solvent. Solvent molecules pass through the membrane, diluting the solution and thereby increasing the volume on the solution side and forcing the solution to rise up the glass tubing. The process continues until the pressure exerted by the solvent molecules on the membrane is balanced by the hydrostatic pressure of the solution in the tubing. A sample of the solution is then removed and its concentration determined. Osmosis is a colligative property; therefore the method can be applied to the determination of relative molecular masses, particularly for large molecules, such as proteins, but it is restricted by the difficulty of preparing good semipermeable membranes. As the osmotic pressure is a colligative property it is directly proportional to the molar concentration of the solute if the temperature remains constant; thus π is proportional to the concentration n/V , where n is the number of moles of solute, and V the solvent volume. The osmotic pressure is also proportional to the absolute temperature. Combining these two proportionalities gives $\pi V = nCT$, which has the same form as the gas equation, $PV = nRT$, and experimental values of C are similar to those for R , the universal gas constant. This gives considerable support to the kinetic theory of colligative properties.

Osnaburg: A traditional coarse cotton cloth, named after German town Osnaburck where it originated, woven with uneven yarns and often incorporating cotton waste. If the cotton used is fresh (new), it is called Clean Osnaburg. Sometimes it contains partially cotton waste it is called P.W. Osnaburg. A typical construction is 36 x 30 with 7s warp and weft. It is plain weave, resembles crash in appearance, and is the basic fabric from which Cretonne may be made.

Ostads: A twilled and thoroughly fulled woollen cloth with nap raised, shorn and calendered; now obsolete. Originally from Holland.

Ostwald hue number: The number allocated to each of the 24 hues in the Chromatic circle.

Otting process: Multicolour process for colouring carpets, with the work being done without thickening.

Otto witt theory of colour: An early theory of dyes first formulated by O. Witt provided a basis for understanding the reaction between colour and structure of the molecule. According to the O. Witt colour theory a dye is made up of two essential kinds of parts, Chromophores and Auxochromes. He designated a group that produces colour as a chromophore (Greek, Kuroma = colour + Phors = carrier). Chromophores are unsaturated groups. Presence of at least

one such group is essential to produce a colour in an organic compound and a molecule containing such a group is called as chromogen.

Ottoman: A heavy fabric with broad, flat crosswise ribs of even size. Some Ottoman have small ribs, and Ottoman cord have alternating wide and narrow ribs.

Ottoman cord: See **Ottoman**. Basic yarn used may be silk or wool, but now more likely to be acetate, viscose, triacetate, or cotton. The weft cords are usually cotton yarn covered by the warp yarns. It is a stiff unyielding fabric. Used for plain dresses, coats and curtains.

Ottoman cloth: Light to heavy, stiff cloth with transverse ribbing, where the ribs are distinct and can be of even or different sizes (approx. 3–5 per cm). Worsted yarns are practically the only suitable type to use as warp yarn, and the weft can either be worsted yarn or carded yarn. Bonding: smooth or patterned ribs. Woollen ottoman cloth is primarily used for ladies' suits and coats, upholstery and soft furnishings. Fabrics used for suits and coats are often raised on the reverse side to provide better heat insulation. Usually they are piece-dyed goods.

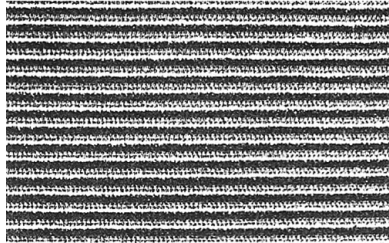

Ottoman rib: Finely ribbed ottoman cloth in particular falls into the *épinglé* category, and is primarily used for covering upholstered furniture.

Ottoman: A lustrous plain woven silk fabric with heavier cross ribs than *faïlle*. The warp completely covers the filling, which is of cotton.

Ottoman Cord: A silk or wool dress fabric, made with very heavy warp, forming ribs and much -finer, hard spun filling, which entirely covers the warp in plain weave.

Ouate Vegetale: French trade term for various tree cotton fibres; used for stuffing.

Ounce: (1) (fluid) – volume equal to approximately 29.57 millilitres in the US, or 28.41 millilitres in Canada and Britain.

(2) (weight, avoirdupois) – approximately 28.35 grams.

Ounce Thread: Fine linen yarn for laces and embroideries. Also called Nun's thread.

Oushak Rugs: Usually large sized, all wool rugs made in Asia Minor. The medium long, soft and loose pile is tied in Ghiordes knot.

Outerwear: Garments such as shirts, blouses, trousers, skirts, jackets, coats, as opposed to underwear. See **DOB; HaKa; KOB.**

Outflow quench: Air for cooling extruded polymer that is directed radially outward from a central dispersion device around which the filaments descend.

Outing cloth: An old fashioned term which was used to describe a variety of flannel-type woollen fabrics. They are plain or striped and often used for blazers, cricket trousers etc.

Outing Flannel: (1) An all-wool or cotton mixed fabric; used for men's and women's outing garments. It is woven with a four-leaf, even-sided twill, full, napped, shorn and pressed; (2) A flannelette, made in imitation of the above.

Outline: Thin, sketchy lines drawn around (print) patterns; contour, bordering. In print designing: Fine line printing. Clarity is mainly dependent on the thickeners used.

Outline stitch: The outline stitch is the simplest of all embroidery stitches. Take a long stitch on the surface, with the needle pointing towards the chest in the line to be covered, and a short back stitch on the under side of the material. The effect of the under or wrong side of the material is exactly that of an ordinary back stitch. The beauty of this stitch depends upon its regularity and in always keeping the thread on the same side of the needle.

Outseam: The distance from the bottom of the trouser leg to the top of the pant at the waist. The measurement is taken along the outside leg seam that joins the front and back leg panels, and includes the width of the waistband.

Outside seam: A seam formed in which in which the completed seam allowance is located on the exterior of the object, usually on the face side of the fabric.

Outside-leg length, inbody measurements: The distance from the side waist to the soles of the feet, following the curve of the body.

Ouvre: French term for fabrics having checks and other small patterns, produced on an ordinary loom. See **Damasse.**

Oven: Enclosed heating equipment used by garment manufacturers to apply heat for the purpose of applying heat to a garment to set, or cure (bake), a durable press finish on the article.

Oven dried wool: Wool dried to moisture equilibrium under specified conditions.

Oven dry: The condition of a material that has been heated under specified conditions of temperature and humidity until there is no significant change in mass.

Oven-dried: A descriptive term for a material that has been heated under prescribed conditions of temperature and humidity until there is no further significant change in the mass of the material.

Oven-dry mass: The constant mass obtained by drying at a temperature of 105–110°C.

NOTE: A ventilated drying oven (that has a positively induced air current) or other suitable oven must be used for determination of the oven-dry mass.

Oven-dry weight: The constant weight of a specimen obtained by drying in an oven under prescribed conditions of temperature and humidity.

Overhanding: See **Whipping stitch**.

Overall: Work wear usually designed to be worn over everyday clothes to give protection to body and part of the leg of the wearer.

Overcasting: Overcasting is a slanting stitch used to keep raw edges from ravelling. This stitch, like over sewing, may be worked from right to left or from left to right.

Overcheck: Two checks of different colours woven over each other, or a check design introduced over a ground check. Generally, the overcheck is of a different colour.

Overcoat: (top coat) Dark, self-shaded or conservatively patterned (mottled) carded yarn cloths (e.g. Marengos); high-quality fabric in almost all types of finish. The fabric is used for smart, timeless coats of the same name.

Overcoat stitch: Embroidery stitch. Bring the laid threads through at one point and hold with left thumb. The bring through the working thread at the same point and work small Satin Stitches closely over the laid threads, following the line of the design. The laid threads are taken through to the back of the fabric to finish. This stitch resembles a fine cord and is useful for embroidering delicate stems and outlines.

Overcoating: Fabrics woven especially for overcoats—covert, kersey, melton, beaver, frieze, vicuna, whipcord, cheviot, chinchilla, etc., made of both wool and worsted.

Overcut: A staple fibre that is longer than nominal length. Usually, the length is a multiple of 2, 3, or more times the nominal length. An overcut is

caused by the failure of filaments to be cut to the desired length during staple manufacture.

Overknit: See **Double pique**

Over drying: Excessive drying of fibre material, so that the capillary water content is removed. Heat and over drying are damaging to a greater or lesser degree for any textile fibres, if allowed to take effect under uncontrolled conditions as opposed to controlled heating.

It can result in thermal splitting of polymer chains. (Drying.)

Over dyeing: When dyeing takes place on top of a previous colouring process.

Overedge stitch: A type of chain stitch, in which the needle thread loop is carried from the underside of the fabric over the edge and turned to the line of stitching to be secured by the needle on it in next downward stroke. Varying amount of edge cover can be obtained by using machines employing more threads.

Over edging or over locking: The use of overedge stitching either by hand or machine to bind the edge to avoid fraying. It is sometimes used as a decoration and often described as overlocking or serging if done by machine.

Over feed devices: Device particularly on pin stenters, to allow lengthways shrinkage during fabric tensioning (see Fig). Over feed devices consist of two pairs of powered rollers located above the clip chains, which feed the fabric to the chains at a higher speed than the chains are capable of. This means that the fabric edges are fed onto pins while they are in a crimped position. Clip stenters have specially constructed clips with slits.

Overfeed systems: See **Over feed devices**. Fabric advancing devices for compression and crimping, e.g. on pin stenters, compacting, sanforizing machines, etc.

Overflow dyeing machines: This rope dyeing machine system for woven cloth and knit goods, is particularly suitable for delicate fabric types, and was designed on the basis of the overflow principle, which is easily manageable.

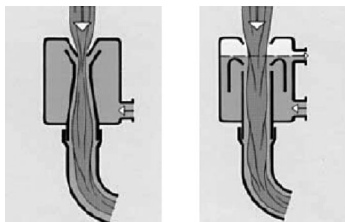

Nozzle System

Overflow system

Overlap, in knitting: Overlap refers to the section of stitch in the warp knitted fabric. The yarn that is wrapped around the needle hook is called the overlap. Overlap is rarely taken across two needle hooks.

Overlength: See **Overcut**.

Over locking: A sewing process which cuts and forms stitches round a raw edge, preventing the fabric from unraveling. This is the generic name given to over-edge stitch machines used to trim and cover the rough edges of the fabric in order to present a clean and neat appearance where seam edges are visible. Over lock machines are also used for the assembly of some types of knitted articles such as T-shirts.

Overplaid: Apparently a larger plaid woven on top of a smaller plaid or stripe design.

Overprint: In dyeing, a direct print covering lighter colour shades, not affecting the dye underneath.

Over-reduction Undesirable characteristic of certain vat dyes, caused by factors such as an excessively high dyeing temperature, excessive levels of sodium dithionite in the dye liquor, extended dyeing periods, or a combination of these factors.

Oversack: An overcoat.

Oversewing: See **Whipping stitch**.

Overshirt: An outer or top shirt.

Overshot: See **Float**. Term in England for floats formed by the weft.

Oversleeve: Separate sleeves of almost any material worn by bookkeepers, clerks, etc., to protect shirt or coat sleeves.

Overspraying: A term sometimes used to describe the application, by spraying, of a fibre lubricant to staple fibres during opening and blending.

Overspun: Irregular yarn, showing too much twist at the thin places.

Over-the-counter: A term that usually refers to direct sales to a retail customer in a store, as opposed to wholesale marketing.

Owb(or o.w.b.): On weight of bath; usually expressed as percentage; omb is on mass of bath - preferred modern usage The amount of some constituent of a dye bath or other process bath based on the weight of the bath. For example, something specified as 6% owb would require 6 gram of that item per 100 gram of bath. Since the bath is invariably mostly water, which weighs 1 kilogram per litre, calculations in the metric system are much easier.

Owf (or o.w.f.): On weight of fibre, usually expressed as percentage; omf is on mass of fibre - preferred modern usage Often this is synonymous with owg but distinction may be appropriate when considering a particular fibre in a blend.

Owg (or o.w.g): On weight of goods; usually specified as percentage; omg is on mass of goods - preferred modern usage The amount of dye or auxiliary chemicals used is often based on ratio to the weight of the goods to be dyed. For example, if a formula calls for 3% dye owg, and 400 grams of fabric are to be dyed, the required amount of dye would be 3% of 400 grams, or 12 grams. Owf may be more accurate when blended fibres are considered.

Oxford weave: A modification of plain weave in which two warp yarns weave together as one.

Oxford: Bi/multi-coloured woven cotton shirt fabric with a “sturdy” appearance; usually calico weave; occasionally also available as Panama or cotton twill weaves. Due to its soft, voluminous effect, it is also known as “non-raised flannel”. 2-thread warp and coarser weft, causing the Panama effect.

Oxford cloth: A cotton fabric that looks as if it were woven with a basket weave, oxford actually has a fine warp and a coarse filling. A characteristic construction is 76 x 38 with 36s warp and 15s weft. Combed mercerized yarns are used, especially in the warp. Now a days it is made with a cotton viscose or modal mixture cloth, usually in basket weave and often with a white filling yarn. It is an inexpensive fabric more expensive if mercerized cotton is used. Mainly used for shirts, light suits, dresses.

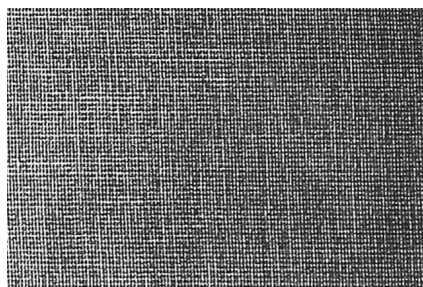

Oxford Gray: Various fabrics, made of yarn containing black and white fibres mixed in various proportions.

Oxidative washing agents: This type of washing agent can consist of soap, alkali (sodium carbonate, phosphates, etc.), stabilizers (magnesium silicate)

and a source of oxygen (sodium perborate, percarbonate, perpyrophosphate). Oxygen salts ensure that the alkali level is not too high and will therefore cause no damage. Modern oxidative washing agents contain appropriate synthetic surface active detergents instead of, or in addition to, soap.

Oxidising agent: A chemist's term for any chemical that causes loss of electrons from another chemical with which it reacts; the oxidizing agent is itself reduced (see reducing agent) in the process. Oxygen is the oxidizing agent whence the name comes. Chlorine is another strong oxidizing agent. As an example, when sodium reacts with chlorine, sodium chloride (common salt) is formed. Sodium loses an electron in the process (going from Na to Na⁺), and chlorine gains an electron (going from Cl to Cl⁻). Strong oxidizing agents + - must be handled with care, since contact with substances that burn may cause fire.

Oxo Wool: A flax substitute for wool.

Oxycellulose: Cellulose damaged during oxidation (more or less broken down by oxidizing acids, bleaching agents, kier-boiling, etc.). The properties are analogous with those of photocellulose and Hydrocellulose. Test: oxycellulose on its own: Gold purple reaction; Nessler's reagent; Phloroglucinol reaction. In addition, as with hydrocellulose, with: Prussian blue reaction; Fehling's solution; Methylene blue test; Vatting test, Turnbull's blue reaction.

Oxycellulose, test for: See **Gold purple reaction**.

Oxygen demand: (waste water), The usual methods of analyzing waste water pollution are the Chemical oxygen demand (COD), measured by the amount of potassium dichromate (K₂Cr₂O₇) used, or the Biochemical oxygen demand (BOD).

Oxygen fading: See **Ozone fading**.

Oxygen number of plumage: A measure of the degree of cleanliness; the amount of oxidisable water soluble and fine suspended matter present in the water extract.

Oxygen depletion: Bacteria are responsible for the depletion of most organic impurities, consuming oxygen at the same time. It is essential that the microorganism/ waste water interface provides water-soluble conditions, and that the molecular weight is low, to ensure that penetration into the bacteria cell is possible. The bacteria cells do not absorb polymers.

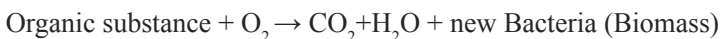

Oyah Lace: Coarse Turkish crochet lace made of coloured silk yarn.

Ozier: Early maturing .commercial variety of upland cotton, the staple measuring 25-28 millimeters, forming medium bolls; the yield is 30-32 percent.

Ozonation, in ETP: The injection of an *ozone* air mixture into clean filtered water, normally to disinfect the water but sometimes for other reasons, such as removal of colour or oxidation of manganese. Ozone quickly decomposes to oxygen. It is made on-site in an *ozoniser*. Ozone is a powerful disinfectant. For water disinfection, 5 to 10 minutes contact time is needed if there is 1% ozone in the ozone-air mixture injected into the water. It is a more efficient disinfectant than chlorine, but ozone decomposes in a few minutes whereas chlorine residuals last many hours. Ozone has a lower tendency to make undesirable *disinfection by-products* than chlorine (*see bromate*). The main disadvantage is the cost of making the ozone and the lack of any *residual disinfectant*. For wastewater disinfection, the lack of any residual ozone can be an advantage, because, in *chlorination*, the chlorine residual can be a problem for the receiving water.

Ozonator: A device which generates ozone by passing a high voltage current through a chamber containing air or oxygen. Used as a disinfection system.

Ozone (O₃): oxygen molecule with three atoms. Individual free oxygen atoms (known as “oxygen in status nascendi”, which have an extremely high level of oxidation energy Ozone bleach) accumulate around O₂ molecules and combine with them to form ozone.

Ozone bleach: Industrial development of an old type of bleach known as grass bleach, designed specifically for linen, less suitable for cotton. It has not been implemented on a large scale, both for cost reasons and also because it has no particular advantages over other bleaching processes.

Ozone fading: (oxygen fading), the appearance of oxidative bleaching of blue, red and yellow dispersion dyes caused by the effect of atmospheric ozone, which is similar in appearance to gas fume fading. This effect is most common in acetate, triacetate and polyester dyes. Heat treatment of triacetate and polyester improves fastness to ozone fading. Ozone fading can be prevented, by using anti-oxidation agents such as diphenyl ethylene diamine (also used as a gas fading inhibitor) and para-octylphenol (which has no gas fading inhibition properties), which means that using the methods detailed here, both gas and ozone fading can be prevented at the same time.

Ozone fastness: Common in the USA, meaning the resistance of textile colour to the effects of atmospheric ozone in the following conditions: (a) Air humidity below 65% at normal temperature; (b) High air humidity of at least 80% at a raised temperature (40°C). Samples, and also control samples, are subjected to the effects of ozone in special chambers under the above conditions. The colour change is evaluated by means of a grey scale after a certain number of cycles.

Ozu Aya: In the Japanese trade name cotton jean.

Ozoniser, ozonizer: An electrical discharge unit operating at 5000 to 20 000 V and 50 to 500 Hz, which converts some of the oxygen in air to ozone. It produces air with about 1% ozone. Dust and moisture must be removed from the air before entering the ozoniser, otherwise flashover occurs.

P

P.F.D.: Short form for Prepared For Dyeing.

P.F.P.: Short form for Prepared For Printing.

PA: Polyamide fibres.

Pack, in spinning: (1) The complete assembly of filters and spinneret through which polymer flows during extrusion. (2) A unit of weight for wool, 240 pounds. (3) Linen yarn measure, equal to 60,000 yards.

Pack duck: In England a coarse, stout linen fabric; used for packing.

Pack life: The time during which a pack assembly can remain in use and produce good quality yarn.

Pack Thread: Very strong twine; used for tying bundles. It is made two or three ply, of hemp or flax, in various thicknesses and fineness.

Package: See **Packages**. Wound package, consisting of a tube and winding, e.g.: Pirn; Crosswound yarn package; Flanged bobbin; Hollow cop.

Package build: A general term that applies to the shape, angles, tension, etc., of a yarn package during winding. Package build affects performance during subsequent processing.

Package density: Density of a package is its g/volume. Uniformity of package density is important.

Package dislocation: Deformation of crosswound yarn packages, yarn slides off the dyeing tube.

Package dyeing: Also called **Pack dyeing**: The forced circulation of dye liquor through packages of fibre, yarn or fabric, without limitation of temperature. Advantages: Short liquor ratio, direct use of the yarn package for warping or warp yarns on the sizing machine. Disadvantages: Absolute evenness cannot be guaranteed in hard packages.

NOTE: The use of the term “pressure dyeing” in this connection is deprecated. (See also **high-temperature dyeing**.)

Package dyeing: See **Dyeing**.

Package winding: The winding of a Package (Crosswound yarn package) determines its properties during further processing and thus the quality of the

end product and the effectiveness of production. This has a critical influence on characteristics such as for example consistent package density or good run-off characteristics. Traditionally, there are two package winding systems: Random winding and precision winding.

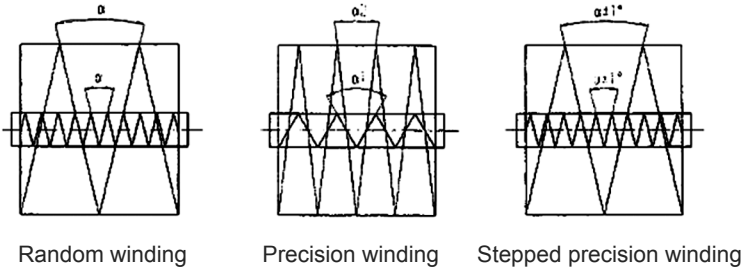

Package dyeing machines: (1) Yarn packages are packed and if necessary, compressed on material carriers, which are transported by conveyors and craneways to the dyeing machine in question. In dyeing machines supplied with a centrifugal pump or an axial pump the dyeing liquor flows through the yarn package columns. Dyeing machines, circulating liquor type. (2) Dyeing machines for crosswound yarn packages, bottle package, combed top bobbins, card sliver and warp beams.

Package hardness testers: The package hardness is an important criterion for faultless full penetration dyeing. A densimeter, which detects the Shore hardness, is used for hardness testing.

Package hydro-extractor: (package centrifuge) Centrifuge hydro-extraction of yarn packages. These are deformed in normal centrifugal baskets, which is why baskets with spool carriers or single spool centrifuges are used.

Packages: A large selection of forms for winding yarn is available to meet the requirements of existing machinery and a variety of package builds is used to ensure suitable unwinding in later stages of manufacturing. Since a package with flanges cannot be unwound easily and quickly by pulling the yarn off overend, most packages are flangeless with self-supporting edges. Some can be unwound at speeds up to 1500 yd/min. The accompanying diagram shows six common types of yarn packages.

Packed bed filter: Any treatment process in which a solid medium is packed into a tank or tower. Examples in water and wastewater treatment include anaerobic filter, pre-anoxic filter, denitrifying filter, nitrifying filter, rapid deep bed filter.

Packed bed scrubber: A type of wet scrubber consisting of a tower packed with media (typically plastic media or metal mesh or wooden slats) down

which the reagent (scrubbing or wash water) trickles. The air flow to be cleaned normally flows up through the tower (i.e. countercurrent to the scrubbing liquid). Gases with a high concentration of particulates may clog a packed tower. A packed bed scrubber can also be used as an entrainment separator. *See Moving bed scrubber.* (1) A bioscrubber. (2) The term may be used to mean a packed tower aerator.

Pad: (1) Impregnation on a padder. Differentiated according to procedure e.g. Pad-batch process; Pad-dry- process; Pad-jig-process; Pad-Roll-Process; Pad-Steam-Process.

(2) A flat, compact cushion or mattress shaped implement laid upon the lap-board or any other press-board and used in “pressing-off” and giving form and finish to a garment. Its elasticity accommodates it to any inequalities of the garment and therefore the whole surface is reached by the pressure of the iron and made smoother and solider than it could be without its use. *See Looney.*

Pad batch: A sequence of operations involving padding and batching without intermediate drying.

Pad batch process: (Cold pad batch dyeing), performed on the padder; high performance fabric opening and rolling machines guarantee crease-free material flow without edges rolling up from material entry to the nip. On the way from the nip to the rolling point the material is fed over additional rubberized rollers. The fixed material feed prevents the material from stretching lengthways and the edges from rolling up. This requirement to prevent rolling up on the batch roller is achieved by an adjustable hydraulic force on the last transfer roller. The material tension is modified to suit the process using a computer controlled centre roller. The following material qualities can be dyed economically, gently and with reproducible effects using the pad-batch process:

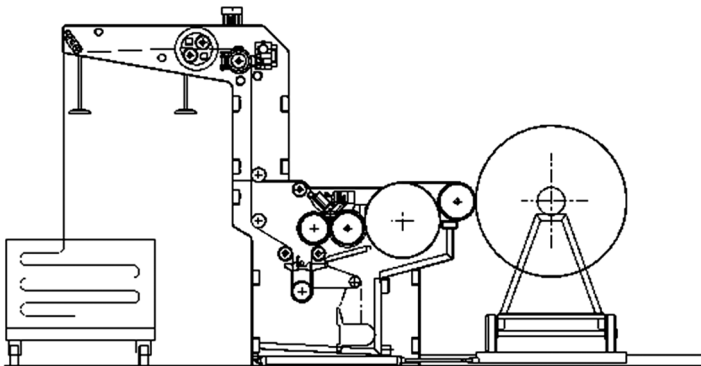

- (a) Knitted fabrics: Single jersey, interlock, lining fabrics, nikki plush,
- (b) Woven fabrics: Mercerized and non-mercerized cotton fabric, inlet material, cord, terry fabric.

After the padding and cold dwelling the material must be washed in a suitable manner.

Pad dyeing: See **Dyeing**. Pad dyeing (continuous or semi-continuous systems). This process is carried out using mechanical means (pad-batch wetting). The dyeing liquor is distributed homogeneously onto the fabric (i.e. also the dye is distributed homogeneously). In a second stage the dye penetrates into the fabric and is then fixed. At the end of the process the material is washed.

Pad printing: Complete printing of a material with the Kiss roll; Thousand-point roller or hatching roller.

Pad process: Used for padding (Padding). The material is impregnated with liquor containing the dye or chemical on the padder, whereby the substantivity of the application product is almost eliminated due to shorter submersion time and shorter liquor ratio. Unlike the exhaustion processes, material flow is continuous, as the first work stage, if necessary followed by a second wet treatment (wet-on-wet-padding).

Pad roll: A sequence of operations involving padding and wet batching with a provision for intermediate heating. In this process goods are padded through the scouring solution and then batched open width onto rolls which rotate slowly for several hours ranging from 6 to 24 h depending upon the type of cloth. The goods are then washed and rinsed in open width washers.

Pad-Develop-Thermosol-Process: Pad-dyeing technique for polyester/cotton using vat leuco ester and disperse dyes.

Pad-dyeing: The Pad process is replacing discontinuous dyeing methods for woven fabrics to an ever greater degree. Function mode of padder with swimming rolls.

Pad-fix-process: Pad-dyeing process for polyester spun tow. The tow, which is padded with the dye dispersion, is either packed into a packing cylinder or wound onto a perforated cylinder and dyed in the liquor in the HT circulation machine.

Pad-steam-roll system: After impregnation with scouring liquor, the fabric is quickly pre-heated in a steam chamber or by an infra-red radiation. When it has reached a high enough temperature, the fabric is introduced into a transportable reaction chamber heated by steam injection, where it is stored in a rotating roller. The reaction time is of the order of 1-1.5 h at 100°C.

Padder: Open-width dyeing machine, padding machine for open-width treatment, padding, impregnating, (padder) delustering etc. of piece goods (loose material on special padders.) The task of the padder is to remove the excess liquor absorbed in the dyeing trough by uniform squeezing across the entire width of the fabric.

Padder-Jig-process: Garment panels are padded with dye solutions and developed or fixed on the jigger. The process is of particular practical interest in the dyeing of cotton and linen woven fabrics using vat dyes and also direct dyes to a lesser extent. Advantage: Better penetration and dyeing of larger batches. Disadvantage: The discontinuous vatting can sometimes cause lack of end-to-end uniformity in the full bath of the jigger, because some of the dye is transferred into the blank vat. These faults can be rectified by the addition of padding liquor to the bath at the start and end of the first passage.

Pad-roll bleach: Semi-continuous process for cotton, cotton/polyester mixes, reclaimed cellulose. Material is impregnated with bleaching liquor and batch rotated and dwelled in a heated chamber.

Pad-Roll-Process: Discontinuous pad-dyeing process for dyeing cellulose fabrics with direct dyes, in batches of up to 5000 m. The woven fabric impregnated with the dye is heated up to approximately 100°C in a pre-chamber by IR emitters and wound in an adjoining travelling and heatable chamber. When winding is complete the chamber is connected to a steam line (direct and indirect), whilst the skein slowly turns (“roll”). Dwell time is dependent upon the colour depth.

Pad-steam continuous dyeing: A continuous dyeing process for many dyes where the dye and chemical is padded in one or two padders and steamed for fixation and the further treatment is done continuously. One of the widely accepted method of dyeing in the open width form.

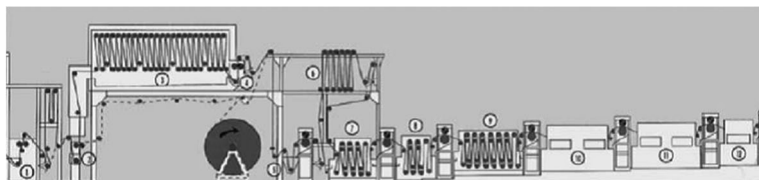

Pad Steam Range

Pad-steam process: A process of continuous dyeing in which the fabric in open width is padded with dyestuff and, if necessary, with a reducing agent, and is then steamed. (See also **padding**.)

Pad-thermofix process: General term for the pad dyeing process using reactive and/or disperse dyes.

Pad transfer technique: Low wet pick-up technique by transfer, e.g. QS-process.

Pad-wet fixation process for reactive dyes: Pad-wet fixation process for reactive dyes (Hoechst), continuous process according to the principle: Padding with neutral dye solution, drying, passage through hot, saline, alkali solution.

Pad-wet process: Dyeing process, in which development or fixation of the dye after padding takes place without an intermediate drying stage.

Pad-winch process: (Pad-Winch beck), process for dyeing difficult to penetrate woven fabrics (above all those made of viscose staple fibres with direct dyes). Material is padded with the dye solution and then treated by boiling with a sodium sulphate or sodium chloride

solution on the winch beck, whereby the dye is fixed.

Padder-jig: Combination Padder with Jig dyeing, whereby the upper padder roller functions as a jiggging roller. Used for discontinuous dyeing (Pad jig-process) with vat, vat leuco ester, reactive dyes, etc.).

Padding: (1) The application of a liquor or a paste to textiles, either by passing the material through a bath and subsequently through squeeze rollers, or by passing it through squeeze rollers, the bottom one of which carries the liquor or paste. The entire padding function can be divided into elementary functions: (a) Submersion of the textile material in the liquor for mixing. (b) Squeezing the loaded textile material for proportioning. (c) Transport of the reaction mixture (textile material with defined product application).

(2) A dyeing method with very low liquor to goods ratio, where typically only enough strong dye solution is used to saturate the fabric Padding can have the advantage of high dye yield. Padded goods are usually "batched" - wrapped in plastic and left for some period of time for the dye to attach to the fibre, or steamed to fix the dye quickly. Padding methods are sometimes used for other textile processes such as bleaching.

(3) Felt, cotton or wool used for giving shape to garments.

Padding machine: A machine used for padding. See **Padding, Padder**.

Paddle dyeing machine: A machine used for dyeing garments, hosiery, and other small pieces that are packaged loosely in mesh bags. The unit consists of an open tank and revolving paddles that circulate the bags in the dyebath.

Paddock: (1) It is a worsted cloth which resembles gaberdine in weight and moisture repellency.

(2) A rather long, slightly formfitting overcoat, somewhat similar to the Newmarket.

Pador gum: Lowest quality class of Senegal gum.

Padou: A narrow silk ribbon in France.

Paduasoy: Stout, rich Italian silk fabric; name obsolete, the fabric being known as peau de sole.

Paenula: Ancient oval or diamond shaped cape with head opening, closed all around or slit at the front; often with a hood.

Pailletine: (1) (Yarn) rice straw yarn for furnishing fabrics. (2) (material) Fine clothing material similar to Paillette; 8 Thread, reinforced satin.

Paillette: (1) Sequins, mica; thin perforated metal or glass plates for applying to clothes.

(2) Light, shiny clothing, blouse or lining satin with a soft handle (Satin de Chine); 5 or 7 thread warp satin.

Pailletine: (1) (Yarn) rice straw yarn for furnishing fabrics. (2) (material) Fine clothing material similar to Paillette; 8 thread, reinforced satin.

Paisley: A fine fabric always with scroll designs. Originally only from Scotland, a 'paisely' meant a shawl made in fine soft woollen yarn, with a woven pattern. Original designs are from India. Real paisley cloth is very expensive, but anything of any fibre or mixture printed with the traditional elaborate multicoloured scrolls is described as paisley design.

Paisley pattern: Distinctive tear drop/mango shape decorative pattern based on traditional on Indian pine or cone motifs.

Paita: Variety of raw cotton from Peru; see **Payta**.

Pajamas: A two piece ensemble consisting of a top and bottom generally used for, but not limited to, night wear.

Palampores: A kind of chintz bed-cover, sometimes made of beautiful patterns, formerly made at various places in India. The word palampore is originated from the Hindi/Persian word Palangposh (Bedcover) but palmpores were not just ordinary counterpanes. The printing is done using laborious kalankari (printing with natural vegetable dyes) technique that involved penpainting a part of the overall design with a mordant, then dyeing. The dye would fix to the cloth where the mordant has been applied, and the artist would then sketch another part of the design for dyeing in a different design fir dyeing in a different colour. The process is repeated till the entire design is complete. Since it is time and labour intensive the Palampores is never cheap.

Palempore: See **Palampore**.

Paletot: A long, loose overcoat.

Palla: Ancient rectangular woollen cloth used as a robe by women out of doors; often covered the head.

Pallium: Ancient men's rectangular woollen cloth outer robe, wrapped the body, over the tunic.

Palmer: Open-width tensioning device on the felt calendar for decatizing/drying open-width materials.

Pallas: French pile fabric; used for coating, made of cotton warp and filling and long goats' hair warp. It is either dyed black in the piece or printed in fur effect.

Pallav: The end part of Sari worn by Indian women. On wearing the sari the pallav comes out over the shoulder towards behind of the person, or sometimes in the front of the person, in different type of wearing a sari. Pallav will have different pattern compared to the other parts of the sari. The nature of design will be in harmony with the body of the sari. There is always a distinct relationship between the border, body and the pallav. Some saris will have Pallav at both ends (usually the nine yard Saris). The two pallavs are embellished differently. This enable the wearer to drape the garment from either end with different pallav each time.

Palm fibres: Vegetable fibres of numerous palm types belonging to the group of Hard fibres, mainly in the form of so-called vegetable horse hair substitute, for brushes, braiding, upholstery material, etc. We differentiate between the dwarf palm fibre (Algeria, Morocco, Spain), the date palm fibre (similar to coir fibres) and further bassine, crin d'Afrique, kitul fibre, panama fibre, para fibres (the most important), piassava fibre, rafia bast, tecum fibre. They are all of regional importance only.

Palm Oil: Palm oil has a high content of a C16 saturated acid (40% palmitic acid). It also has a high content of oleic acid, 43%. This combination of fatty acids is ideal for making good toilet soaps

Palmer: A Palmer unit is a large heated cylinder with an endless rubber belt pressing against it. Normally used along with Sanforising, Safor-set processing units in the final stage of the finishing process to give an ironing effect with sheen, for the fabric. Open-width tensioning device on the felt calendar for decatizing/drying open-width materials. Modern design Pin wheel.

Palmet: Strong black leaf fibre yielded by the *Prionium palmita* in South Africa; substitute for horsehair.

Palmette: Shawl made in France with a foundation of two-ply wool warp and combed wool filling, and carded wool yarn for the figures.

PAM: Modacrylic fibres.

PAN: Polyacrylonitrile fibres.

Panache: French for high and variegated coloured effect.

Panama: Very lightweight cloth used for men's summer and tropical wear and women's dresses. The yarns used are cotton and worsted in the Traditional Panama cloth, although other fibres such as polyester and viscose are sometimes used. The cloth has recognizable square-weave effect, and is usually in plain colours.

Panama: Plain woven worsted dress goods, dyed in the piece; hopsacking made of coarse yarn in basket weave, made plain or in two colours. There is also a dress goods of cotton warp and double wool filling producing an effect similar to the texture of the Panama hats.

Panama canvas: Thick, cream coloured, basket weave canvas; it is beetled and used for embroidery.

Panama weave: Consists of several warp and weft threads crossing each other at once, producing a mat like effect.

Pandanus: A palm in East Africa, India and Polynesia; the leaves are used for mats, baskets, hats.

Paneled Back: The inside back of a coat made with broad facings of the goods around seams and edges, and filled in with (panels of) silk or other lining.

Pang: A Chinese silk dress goods.

Pangalo: A new variety of Egyptian cotton; the staple is described as brownish, of silky gloss and strong.

Panier: Framework for 18th century hooped skirt; typically very wide, but flattened at front and back.

Panna satin: See **Satin**.

Panné Satin: A satin fabric with an unusually high lustre because of the application of very heavy roll pressure in finishing. Panné satin is made of silk or one of the manufactured fibres.

Panne' velvet: Knitted backing of polyester, silk or acetate lustrous, lightweight velvet fabric, usually made of silk with a short pile on the right side that is pressed flat during manufacture.

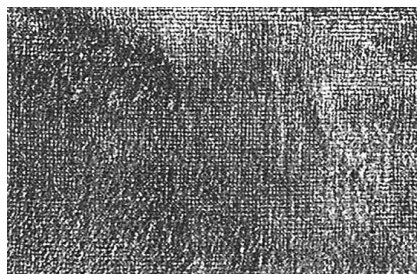

This gives the effect of a shiny shimmery velvet. The fabric is soft and floppy comfortable to wear. It is easiest of all velvets to sew. Used for evening wear, robes, leisure clothes, tops and trousers.

Pannus: A medieval silk fabric, made in Italy.

Pantaloon: Originally calf or ankle length narrow breeches, later full length and held with stirrups.

Panting: Same as trousering.

Pantograph: (micrograph), drawing instrument used in pantograph engraving (Engraving) for the manufacture of calendar rollers. The pattern is transferred from zinc plate onto a calendar roller, which is painted with acid resistant paint, by a heated diamond pantograph, and the engraving is enhanced by etching.

Pantone: A company and its trademark. The Pantone company produces a wide range of colour guides useful in almost any industry dealing with colour. The colours in the guide are widely accepted as standards. Colours are sometime seen described as a Pantone number: Pantone applies a unique number to each colour.

Papeline: Originally a lightweight dress goods, made in Avignon, France, of silk warp and silk waste filling in plain colours, or figured; one side had a selvage of different colour than the warp.

Paper cambric: Lightweight, lustrous cotton lining.

Paper cloth: Cotton, hemp or jute fabric coated with paper on one or both sides, between heavy rollers; used for boxes, etc.

Paper muslin: Light weight cotton muslin, sized and given a lustrous finish; used for lining.

Paper tafetta: A fine-weave, light-weight taffeta which has been treated to make it crisper than usual, hence the name paper. The crispiness is usually a permanent finish.

Paperwork, in designing: Designers initial drawings and design ideas produced on a paper.

Papering: The insertion of cold and heated board elements (paper) prior to pressing, usually in a hydraulic press.

Paper makers felt: A fabric made from wool or manmade fibres or mixtures of both, fabricated as an endless belt for use on a paper making machine to form an endless conveyer belt for pulp or wet paper in its passage through the machine. These products are now also made of various constructions, woven and nonwoven, of manufactured fibres and monofilaments.

Paper yarns: (1) Made of cut narrow strips of spinning paper which (possibly after previous folding) are twisted together on a spinning machine in a moistened state (drilled). Sulphite paper or (tear resistant) sodium or sulphate paper or mixtures of these are used. Finenesses from 33–1000 tex, resistance to tearing from 4–7 cN/tex at 4.5–7% elongation at tear.

(2) Wood pulp yarn is created by twisting together band shaped, wet strips of wood pulp, without previous processing into spinning paper. Finenesses from 33–2000 tex, resistance to tearing 7–9 cN/tex. Application: For carpet underlays, carpet runners, wall coverings, bags, cord, hat braiding, etc.

Papery: Excessive smoothness given to the cloth with the aid of sizes in the finishing process.

Papoon: Plain woven cotton fabric; used in India; made of different coloured warp and filling or in small checks.

Papyrus: The paper reed, *Cyperus papyrus*, of Egypt: the stem fibres are used for cloth, sails, mats, cords, etc.

Para: (1) A chemical prefix, usually abbreviated *p*, indicating that two substituents on a benzene ring are separated by two carbon atoms. (2) Variety of raw cotton from Brazil.

Parachute cloth: A close-weave, lightweight, synthetic fibre or silk fabric with high bursting and tearing strengths.

Paraffin: Paraffin waxes come from a purified mixture of solid hydrocarbons obtained from the distillation of petroleum. This mixture contains C₂₃ to C₃₃ hydrocarbons. Straight chain hydrocarbons are solids, branched ones are oils. The distillate fraction contains both straight and branch chain isomers since they have identical boiling points. When the distillation fraction is chilled, the straight chain hydrocarbons solidify and can be filtered from the oil.

Paraffin: A wax extracted from crude (petroleum) oil (North American usage; in Britain, paraffin means kerosene) Paraffin wax (actually a number of waxes with somewhat different characteristics) is used, by itself or in mixtures with other waxes such as beeswax, as a dye *resist* in batik. It quite brittle and cracks easily. “Canning wax”, sold in North America (and elsewhere, presumably) for sealing home-made jam and jelly and the like, is paraffin. Most candle wax, other than beeswax, is paraffin.

Paraffin waxes: See **Paraffin**.

Paraformaldehyde: Mixture of different polyoxymethylene-dihydrates, DP 3–100, approx. 95% formaldehyde content, develops gaseous formaldehyde from 100°C (space disinfection).

Paraguay lace: Single threads are used to produce spiders web effects/ wheel design, which are then woven together.

Parahyba: Variety of raw cotton from Brazil, having a fairly strong, harsh staple of white colour.

Paring-Off: The process of paring-off the surplus cloth along the margin of a garment, when the edges are made raw.

Paring-Shears: Shears or scissors made expressly for paring the edges of garments.

Paralleling: The process of aligning fibres to produce a more uniform, smoother, stronger yarn.

Parchment cotton: A fine, plain woven colon fabric in England, sized and finished to resemble parchment.

Parellle laying: In the production of a web or batt from single or superimposed card webs laid in the direction of carding for the manufacture of non-woven fabric.

Parallel winding: Even or uneven, slightly helical thread winding, with threads lying side-by-side or one on top of each other. Yarn packages, preparation; Random winding.

Paris Embroidery: Consists of small leaves and berries embroidered with white cord on pique or with floss silk on coloured satin or cloth.

Parisienne: (1) A silk cloth in France made with small patterns; (2) A figured orleans, very fashionable in the middle of the 19th century in France and England; (3) Very soft, lightweight French dress fabric, made black, of merino wool.

Paropa: A fabric made of silk and wool, used in England during the 16th and 17th centuries. Also called peropus.

Part run: A partially filled bobbin that occurs when an end breaks before the completion of a doff cycle. The total weight of yarn normally wound during a cycle is not obtained on the bobbin at the break position. The number of part runs is used as a measure of spinning performance.

Part set: A term that indicates that all guide eyes in a guide bar do not have a **yam** from the warp.

Part wool felt: A felt composed of any one of or a combination of new and recycled wool fibres mixed with one or more man-made fibres, vegetable fibres, or animal fibres other than wool.

Parthenos: French silk velvet dress goods.

Parti-coloured: Hose of different colours, or garments with panels of different colours.

Partial cleavage: In textiles a transverse gouge cut or other crosswise rent in the fibre. Clearly penetrating at least the cuticle of the fibre.

Partially oriented Staple: Staple fibres cut from tow that has been drawn less than normal so that only partial longitudinal orientation of the polymer molecules exists.

Partially oriented yarn: Filament yarn in which polymer molecules are only partially aligned (by reducing the draw ratio).

Particle filtration (PF): Filtration rated in the range of 1 to 75 microns. Typically handled by cartridge filter.

Particulate: Minute, separate pieces of matter.

Partlet: Ancient women's broad shoulder collar used to cover a wide neckline.

Partridge Cord: A mottled corduroy.

Pashim, or Pashmina: Very fine, downy wool found under the hair of the cashmere goat in India; it comes in gray, white or drab colours and is used for the finest rugs and shawls.

Pashmina: Woollen shawls having one-sided embroidery (they have distinct obverse and reverse face) made in Kashmir, India. However on some shawls the embroidery appears similar on both sides of the shawl. In the finest shawls, embroidery on each side of the shawl bears different motifs, accomplished by splitting the warp and embroidering a different motif on each side.

Passing: Thread consisting of a narrow flat strip of gold twisted around a silk core. Used for embroidering and tapestry work. The smallest size is called tambour.

Passing off, in designing: Intentionally trying to deceive customers into thinking a design is by a particular individual or company. This happens frequently with designer labels and branded textiles.

Paste resist printing: Synonym of paste resists (Resist printing): Purely mechanical pre-printed resist made of many high solids thickeners, thickener containing a weighting agent (e.g. kaolin, zinc oxide, lead carbonate, etc.), preferably using indigo and vat dyeing.

Paste resists: See **Paste resist printing, Resist printing.**

Pastille: (1) Pattern consisting of dots only. (2) Round dots, usually of velvet or other thick material woven or applied to nets, veils, etc.

Pastourelle: Plain French serge, made with eight harnesses and four picks in a repeat.

Patagonian: Long staple, heavy shrinking wool from Southern Chile, washes very white; used for hosiery.

Patch Pockets: Pockets made wholly on the outside of a garment.

Patchwork: Needlework, consisting of joining various coloured and shaped clippings of materials with fancy stitches, to form quilts, covers, etc.

Patent Axminster: Pile carpet woven on power loom, chenille being used for filling.

Patent Beaver: All-wool beaver cloth of very fine quality, filled very thoroughly, making the fabric almost waterproof.

Patent Flannel: A very light and sheer English flannel.

Patent leather: A varnished leather that is very expensive. Used mainly for shoes and hand bags.

Pathogens: Communicable diseases can be transmitted by the pathogenic organisms that may be present in the waste water.

Patole: Bordered silk fabric with printed, embroidered or hand painted patterns, made in India. It is made about a yard wide.

Pattern: (1) An arrangement of form; a design or decoration such as the design of woven or printed fabrics. (2) A model, guide, or plan used in making things, such as a garment pattern.

Pattern attachment: A device which controls the pile yarn feed so as to produce a high and low pile surface.

Pattern co-ordination: Co-ordination usually achieved by using selected shapes and motifs from the main design to produce related patterns.

Pattern direction: The way a pattern lies on a fabric.

Pattern draft, in weaving: Point paper design: The diagrammatic representation of the construction is called pattern draft or point paper design. It is marked and read from bottom left to the top right. Vertical columns represent the warp yarns and horizontal rows represent the weft yarn. A mark placed in any cell indicates that the warp is lifted over the weft at that insertion. Absence of a mark indicate the reverse (warp remains below weft). Each cell represent a warp and weft interlacing.

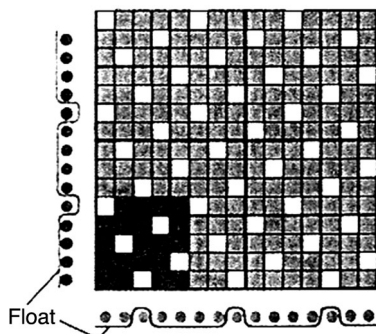

30 – 04 01 – 01 – 03

Pattern Draft of satin weave

Pattern row: Pattern row is a horizontal row of needle loops produced by adjacent needles in one needle bed. In plain weft knitted fabric this is identical to a course but in more complex fabrics a pattern row may be composed of two or more course lengths. In warp knitting, every loop in a course is usually composed of a separate yarn.

Pattern wheel: In a circular-knitting machine, a slotted device for controlling individual needles so that patterns can be knit in the fabric.

Pattu: A pattu is a woollen wrap around woven by women in the hills of Himachal Pradesh, and Kashmir, India. A woven silk material made in Rajasthan, and other parts of India. Pattus are woven on pit – looms, were available only in natural camel or sheep wool shades and had deep contrasting borders. The emergence of synthetic dyes changed that colour coding. Pattu follows a twill weave method but uses a heavy weft- that is wound on small sticks which are shuttled across- for its two ends, lending them an embroidered appearance. The motifs are usually geometric within linear bands. A typical pattu will be always in two segments that are neatly stitched in the centre as the width of the traditional looms are narrow.

Patwa: Very strong bast fibre, yielded by the *Bauhenia vahlii*, a climbing plant in India; used for cordage; also called mohwal.

Paukpan: Bast fibre yielded by the *Aeschynomena aspera*, a small bush in Burma; used for cords and hats.

Paunch Mat: A thick mat woven of ropes and flattened; used in ships.

Payta: Variety of raw cotton from Peru, the staple is of grayish colour, little lustre and strong.

PB: Elastodiene fibres.

PBI: Polybenzimidazole fibre. Made by Celanese Corporation. It is obtained by reacting diaminobenzidine and diphenylisophthalate and is used as an alternate to asbestos in high temperature filtration and thermal protection clothing. Its moisture regain is high at 14.4%, which permits high degree of comfort. Polybenzimidazole, or PBI is nonflammable, comfortable, flexible and used in apparel for space and for drogue chutes and under suit for astronauts.

PC: Polyacrylonitrile fibres.

PCP: Penta chlorophenol.

PE: Polyethylene fibres.

Pea Jacket: A short coat of thick closely woven cloth, worn in rough weather.

Peak force, for pile floor covering: The force required to separate two or more layers and registered on a chart as a peak, that is, a value exceeding the value immediately preceding and following it.

Pearl: See **Purl**.

Pearl printing: Performed on the hank (Yarn printing) using a suitable yarn printing machine, in the form of point single colour illuminating dye.

Pearl yarn: (knitted yarn), pearl ply yarn made up of two different (heavily) twisted single threads (usually with opposing twist).

Peasant Combs: Single-pitch and 2-pitch hand combs used to produce a semi-worsted fibre preparation.

Peasecod-belly: Spanish doublet with heavily padded breast, with a ridge down the middle.

Peat fibres: Peat contains residues of grass, swamp plants, mosses etc. that have decomposed in the absence of air. The dark brown or black strands it contains (approx. 15 cm long) consist of cellulose fibres, which provide a spinnable material.

Peau de Cygne: As the name implies, a very soft satin, woven in fine soft yarns with a lustrous finish. Used mainly for expensive lingerie.

Peau de Soie: Originally made from silk, the term is now also used to describe fabrics made from synthetic fibres, such as polyester and acetate, that have the typical look of Peau de Soie. It is an 8-shaft satin with one point added on the right or left to the original spots, giving the fabric a somewhat grainy appearance. With matt finish on both sides., and is usually a firm, heavy fabric in plain colours. Used for formal dresses.

Pebble: A term often used to describe the characteristic appearance of a crepe fabric.

Pebble-weave fabric: A fabric with an irregular or rough surface texture formed by either a special weave or by the use of highly twisted yarns that shrink when they are wet.

PECE: Post-chlorinated vinyl chloride polymer. The post-chlorination process increases chlorine content from 57% to 64%. The resulting polymer is soluble in acetone and can be wet spun.

Pectinases: Specific Enzymes (belonging to the hydrolases and carbohydrases), which gradually break down high molecular pectins (and hemicellulose) to single galacturonic acid. Pectinases play a decisive role in the biological retting of stalk bast fibres. Used in the retting of Flax. Long and controlled is possible with use of enzyme preparation and no bacterial or fungal contamination occurs like that in dew and water retting. Also pretreatment of flax with SO₂ brings about sufficient break down of the woody straw to speed up enzyme action and to prevent bacterial and prevent bacterial and fungal contamination.

Pectins: High molecular, carbohydrate-like vegetable substance, composed mainly of methylated polygalacturonic acid in a glucosidic bond.

Peel adhesion: The force required to delaminate a structure or to separate the surface layer from a substrate. Peel adhesion is the usual measure of the strength of the bond between fibre reinforcements and rubber in tires and other mechanical rubber goods.

Peeler: In beaming, a defect caused by a portion of an end sticking or remaining on the beam, causing the filament to strip back or peel until it is broken. Although they are often associated with ringers, peelers are not necessarily defects that will circle the beams.

Peg top: Trousers cut wide and full around the hips and narrowing sharply down to the ankle.

Peg-plan: The method of instructing the dobbie mechanism on a loom to lift the required shafts.

Pegging: A finishing process for velveteen consisting of applying friction with blocks of wood or soapstone to impart a gloss or sheen to the fabric.

Pegging jets: A technique for freeing a plugged hole in a spinneret by rubbing the face with a piece of wood. Use of the technique has been discouraged because of damage to the spinneret.

Pegging plan: Synonymous with the lifting plan for dobbies where pegs inlays control selection.

Pekin: These are fabrics in which stripes of a different interlacing run in the direction of the warp. In combining these weaves it is advantageous to have them contrast distinctly, for instance, a short weave such as taffeta or Gros de Tours, with a longer and looser one such as satin, sergé or cannele, also changes from warp to filling effects. Care must be taken to arrange the joining of the two weaves so that the last thread of one weave will cross the first thread of the other. This will prevent the threads from either stripe to slide over into the other, and so make a clean cut line.

Pekinese stitch: An Embroidery stitch. Work Back Stitch is usual way, then interlace with a thread to tone or thread of a different colour. But the loops should be pulled slightly when working.

Pelerine: A device for transferring stitches from the cylinder to the dial or vice versa on a circular-knitting machine.

Pelletes: See **Bassini**.

Pelt: A sheep skin with the wool attached.

Pelts: Term for the hairy outer skin of smaller animals in particular, e.g. rabbits, goats, etc.

Pencil Locked: A fleece with narrow staples or lock formation: indicates an open fleece that has less density and probably more vegetable matter. This type of lock formation is genetic and is passed on to offspring.

Pendant groups: Groups attached to the main polymer chain or backbone. An example is the methyl groups in polypropylene.

Penetration: (1) Penetration of a fibrous mass with the applied liquor, which if possible must wet all surfaces if uniformity of product application is to be guaranteed before fixation. (2) Characteristic feature of printed fabric (roughly comparable to full penetration dyeing), which is particularly dependent upon the type of fabric and thickener. A thick, dense fabric or a suitable filter paper is used to evaluate the penetration capacity of a thickener. Penetration percentages are best obtained by a comparative whiteness measurement. Penetration is = 0% if the printing on a thick fabric remains invisible on the reverse side, i.e. the material still shows its original high, intrinsic degree of whiteness (for thinner fabrics 0% is never achievable, print with very high thickener concentrations is always visible on the reverse). Therefore: Penetration = 100%, the colouring is the same on the reverse and right sides.

Penta-screens: Second generation of Rotary screens for screen printing with mesh values of 125–215. Finer designs can be achieved by using screens with higher mesh values (Mesh number). This is made possible by better mastery of the hole/web ratio by altering the cross-section of the engraving from the sawtooth type to drop-shape. Penta screens require a new special paint.

Improved uniformity and higher printing speed and low doctor blade pressure at the same printing paste viscosity are further advantages.

Pepita: (Houndstooth) These are particular types based on 2/2 twill. The former is said to be named after a Spanish actress and does not show the prominent jagged edges to the squares, which are a feature of houndstooth.

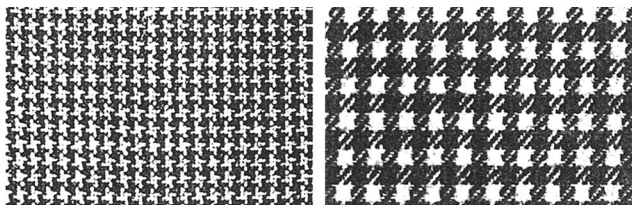

Pepita

Houndstooth

Peplos: Women's rectangular woollen cloth robe, wrapped around the body and fastened over the shoulders.

Pepper-and-salt: Colour patterning effect, also known as thread by thread, in which a light thread alternates with a dark thread in warp and weft, giving rise to a diagonal stripe. Grey shades are typical, but beige brown and other colour combinations are also possible.

Per cent mean deviation unevenness, in yarns: The average of the absolute values of the deviations of the linear density from the average linear density expressed as a percentage of the average linear density within the tested length of the strand.

Per Cent Mean Range Unevenness, in yarns: The average of the ranges of linear density found within segments of equal length, expressed as a percentage of the average linear density equal to within the tested length of strand.

Peracetic acid: Molecular weight 76. A 40% organic acid with 8.6% oxygen. Is classed as explosive; colourless; slightly ionized at pH 8.2. Commonly used as polyester and polyamide bleach, for the stripping of triacetate dyes and also as an oxidative bleaching and stripping agent for proteins and other alkali sensitive textiles, particularly for bright fabrics, for polyamide/ cotton mixes (optimal 65–80°C; not damaging to fibres) and acetate materials (pH 6–8).

Per acids: Acids created by to the action of hydrogen peroxide (H₂O₂) on normal acids, which contain the –O–O–H group instead of –OH, e.g. caro's acid H₂SO₅; Peroxy disulphuric acid H₂S₂O₈; peracetic acid. CH₃COOOH; performic acid. Oxygen releasing principle:



Percalé: A fine print cloth is sometimes called paercalé. Originally a trade name for sheeting made from combed yarns, but today the name is used to describe any fine cloth of medium weight that is woven in plain weave, (180 to 250 threads per square inch). A typical percalé structure is 80s square with combed 40s warp and combed 50s filling.

Percalé: A medium weight, plain weave, low to medium count cotton-like fabric. End-uses include sheets, blouses, and dresses.

Percalé, as applied to bed sheeting: A plain weave fabric with no fewer than 180 yarns/in².

Percaline: Cloth is similar to percalé but woven with still finer yarns and lighter in weight is called a percaline. Light weight cotton print cloth similar to lawn, with a bright soft finish. Usually the yarn is mercerised.

Percent by mass: $\text{Mass of solution} \times 100 / \text{Combined mass of solute+solvent}$. % (by mass)

Percent by volume: $\text{Volume of solution} \times 100 / \text{total volume of solution}$. % (by vol)

Percent UV blocking: 100 minus the UV Transmission. See **UV Transmission**.

Percentage composition: The fibre content expressed as percentages.

Percentage cover: Cover Factor as a percentage of the maximum possible for a particular weave structure.

Percentage point: A difference of 1 % of the base quantity.

Percentage by weight: (weight per cent), is a percentage mass relationship, i.e. grams in relation to 100 gram units, e.g. dye mass stated as a percentage of material weight. Where percentage figures are given in recipes, solvent concentrations etc., and no further information given, the percentage by weight is usually referred to, in solutions Per cent by volume. Conversion:

$$\text{Percentage by weight} = \text{Per Cent By Volume} / \text{density}$$

Perching: (1) A closely woven, plain-weave, spun fabric used for dress goods and sheeting, generally 80 x 80 threads per inch or better.

(2) Examining and correcting raw woollen cloth for and of knots, burs, holes and other imperfections before filling.

Perchloroethylene: See **Tetrachloroethylene**.

Persian carpets: Oriental carpets of Persian origin. Usually dense knotting of 400,000 to 1 million knots per m² with fine patterning. Names such as Bakhtiari carpets; Bijar carpets; Hamadan carpets; Isfahan carpet; Kashan

carpets; Shiraz carpets; Senneh carpets; Seraband carpets (Mir) describe the province of origin.

Percieved value: The value of a product seen to have.

Percolating filter: Used in biological Waste water treatment for enriching the waste water with air.

Performance Fabrics: Fabrics made for a variety of end-use applications, which provide functional qualities, such as moisture management, UV protection, anti-microbial, thermo-regulation, and wind/water resistance.

Performance requirements: How a fabric or product has to function.

Perfume treated textiles: Fabrics are treated with perfumes to give a fresh scent while wearing. In new technology the finishes are capable of refilling with fresh scent when the available scent fades away.

Perkin, Sir William Henry: Founder of the modern dyestuffs industry. (1838–1907), English chemist. In 1856, at the age of 18, discovered the first technically usable coal-tar dye (aniline purple or mauvine) when looking for a quinine synthesis.

Perlon: A branded polyamide fibre.

Permanganate number: (1) Permanganate number. For quantitative determination of fibre damage to cellulose. Oxycellulose and hydrocellulose are dissolved from the fibre by repeated boiling and detected using a potassium permanganate solution. Permanganate number = number of millilitre 0.1 n KMnO_4 solution, consumed by 1 g fibre. (2) Waste water permanganate consumption. Method: Boil 1 g material with NaOH and titrate dissolved organic products with 0.1n KMnO_4 . KMnO_4 consumption up to 10 ml normal, 10– 13 ml little damage, above this significant damage. When making the calculation, deduct the basic value for unbleached material. The Permanganate number can also be an important method of detecting cotton materials kier boiled in the presence of air.

Permanent deformation: The change in length of a sample after removal of an applied tensile stress and after the removal of any internal strain (e.g., by boiling off the sample and allowing it to dry without tension). The permanent deformation is expressed as a percentage of the original sample length.

Permanent finish: A term for various finishing treatments, chemical and/or mechanical, applied to fabric so that it will retain certain properties, such as glaze of chintz, crispness of organdy, smoothness of cotton table damask, and crease, crush, and shrinkage resistance of many apparel fabrics during the normal period of wear and laundering.

Permanent finish: Applications or finishes on textiles, which resist the stresses of use and care, e.g. washing, chemical cleaning.

Permanent growth: See *Secondary creep*.

Permanent hardness: A type of water hardness caused by the presence of dissolved calcium, iron, and magnesium sulphates or chlorides. This form of hardness cannot be removed by boiling. Compare temporary hardness. See also *Water softening*.

Permanent pleating: There is a wide variety of permanent pleated fabric available. It is usually knife pleated, narrow pleats on fine fabric, wider ones on thicker fabrics. The fabric may be of almost any weave, including knit, and may be closely woven or have a lacy pattern. If the fibre is synthetic the pleating will be permanent and therefore washable, but if natural fibres other than cotton are included the pleating cannot be heat set and is therefore probably not permanent. Many fabrics are sold in matching colours, one plain cloth, the other pleated so that garments combining both can be made.

Permanent press: Garment shape is maintained during wearing and washing. Creases must be sharp, flat areas must be smooth. Creases are rated on a 1 to 5 scale. A 5 rating is perfect. See **Durable press**.

Permanent press finishing: Originally used exclusively as a collective term for Resin finishing processes (dry cross-linking), in which the final fixing or stabilizing of the material takes place during garment manufacture. This produces items of clothing with excellent permanent dimensional stability, sharp ironing folds and pleats, nonshrink seams and particularly good smoothness after washing. Fixation is therefore not performed flat, but shaped. Also a common term for conventional resin finishing, however only for items with high-quality finishing effects.

Permanent set: See **Secondary creep**.

Permanent-press finish for wool: Collective term for: Antifelting finish and Non-shrink finish.

Permanent Stitches: Stitches, which are not ripped off after being made, are called permanent stitches. For example-Hemming.

- (a) *Back stitch:* It is a firm hand stitch for awkward areas where machining is tricky. It looks like a machine stitch on the right side but stitches overlap each other on the wrong side. To make this stitch bring the needle out a stitch length beyond where the thread emerges. Insert the thread again at the end of the previous stitch.
- (b) *Half back stitch:* When one does not have much time and a permanent stitch is needed, one can opt for half back stitch. In this stitch, the needle is carried on half-length of the first stitch

- (c) *Prick stitch*: It is a variation of back and half back stitch. It is used to attach Zipper by hand & also to attach sari falls. Back through one or two threads of the fabric, & a bigger distance is taken in front. It is done from the right side of the garment.
- (d) *Hemming*: This stitch is used to fold the raw edges of the fabric or to flatten the seam. It also works from the wrong side of the fabric. This stitch works from right to left with the hem draped over the fingers of the left hand. To make this stitch pick up a thread from the fabric just below the folded edge of the hem and then slip this thread from the fold in the hem itself. It is of three types:
 - (e) *Visible hemming*: This stitch is strong stitch used to fold hemline of a garment. This is called visible hemming because stitch is visible at the right side of the garment as we take three to four strands of fabric to make this stitch.
 - (f) *Invisible hemming*: This stitch is used to attach facing and piping. This stitch is called invisible hemming because we take only one or two strands of fabric to make this stitch and because of it; the stitch is not visible at the right side of the fabric.
 - (g) *Slip hemming*: This is an invisible stitch used to draw two edges together invisibly as in a hand-sewn lining. Slip the needle through the fold and immediately below the needle comes out. Take a small stitch of the fabric. Reinsert the needle immediately above.
 - (h) *Catch stitch*: An invisible stitch worked loosely taking up only a thread of fabric from top and bottom alternately, inside a hem or to hold the inner edge of the seam in interfacing in place.
 - (i) *Herringbone stitch*: This stitch is used on the hemline or during the hemming. It is used for heavy fabric as thick and heavy fabrics needs to be hold at both folds. To achieve this, sewing proceeds diagonally up and down, as in cross stitch, but the needle is brought back slightly behind the previous stitch each time so that it will cross over it.

Permeable: Allowing some material to pass through.

Permeability: The rate of flow of fluid under differential pressure through the material.

Permeate: That portion of the feed stream which passes through a membrane, leaving behind a more concentrated stream.

Permeator: A hollow fine-fibre membrane element itself consisting of thousands of hollow fibre.

Permutit: (Trademark) A substance used to remove unwanted chemicals that have dissolved in water. It is a zeolite consisting of a complex chemical

compound, sodium aluminum silicate. When hard water is passed over this material, calcium and magnesium ions exchange with sodium ions in the Permutit. This is a good example of ION EXCHANGE. Once all the available sodium ions have been used up, the Permutit can be regenerated by washing it with a saturated solution of sodium chloride. The excess sodium ions then exchange with the calcium and magnesium ions in the Permutit.

Peroxide: With reference to textile processes, usually used to mean hydrogen peroxide, though there are many organic and inorganic peroxides.

Peroxide cold bleach: Same process as Peroxide cold-pad-dwell process; Cold pad batch bleach; Cold dwell process. Very suitable as a pre-bleach. Only recommended for clean husk-free raw material.

Peroxide cold-batch dwell process: Bleaching process specifically for cotton circular goods. Method: (a) Impregnate with bleaching and brightening solution on padder using expander for circular material; (b) dwell in heat insulated vehicle; (c) rinse on rope washing machine.

Peroxide pad steam method: The most common process for bleaching cotton fabric. Care has to be taken to avoid heavy metals like iron, which can cause pin hole damage due to the uncontrolled release of nascent oxygen.

Perrotine: Printing machine named after its inventor, Perrot, which can be considered as the first stage in the mechanisation of block printing.

Per salts: Genuine salts of Per acids, such as for example ammonium persulphate or potassium persulphate. Application: Oxidizing agent in dyeing and printing, kier boiling, desizing, bleaching agent; disinfectant.

Persian carpets: Oriental carpets of Persian origin. Usually dense knotting of 400 000 to 1 million knots per m² with fine patterning. Names such as: Bakhtiari carpets; Bijar carpets; Hamadan carpets; Isfahan carpet; Kashan carpets; Shiraz carpets; Senneh carpets; Seraband carpets (Mir) describe the province of origin.

Perso-z reagent: Dissolves only silk from silk/wool mixes at 45°C. Consists of 10 g zinc chloride in 10 g water and 2 g zinc oxide.

Perspiration: Sweating of the human being. There are two types of perspiration by human being: (a) Acidic, (b) Alkaline. See *Perspiration fastness*.

Perspiration fastness: Resistance of dyeing and printing to human sweat. (a) Determination according to DIN 54 020: one sample each is treated with an undyed accompanying fabric in an alkaline or acidic testing solution for 30 min (liquor ratio 1 : 50) at room temperature (slight mechanical action for better penetration). After the removal of excess testing solution the test pieces are individually exposed to a pressure of 12.5 kPa between two plates and are

treated for 4 h in a warming cupboard at $37^{\circ}\text{C} \pm 2^{\circ}\text{C}$. After opening, the test pieces are hung to dry at max. 60°C . The change in colour and the bleeding are evaluated against the grey scale. (b) Perspiration fastness according to AATCC: a) Alkaline: 10 g/l sodium chloride, 4 g/l ammonium carbonate, 1 g/l disodium phosphate (Na_2HPO_4) and 0.25 g/l histidine monohydrochloride, pH of the solution = 8; b) acid: 10 g/l sodium chloride, 1 g/l lactic acid 85%, 1 g/l disodiumhydrogenphosphate and 0.25 g/l histidine monohydrochloride, pH of the solution = 3.5. Procedure: treat test piece for 15–30 minutes in the solutions (a) and (b) individually, squeeze (squeezing effect 250–300%) and load 10 kg for 6 h (or more) in perspirometer at 38°C .

Perspiration Resistant: A treatment on a fabric which allows a fabric or a dye to resist perspiration.

Perspirometer: A device by AATCC for testing Perspiration fastness. Sample is treated at a pressure of 4.5 kg between glass plates for at least 6 h at 38°C .

Persulphate desizing: Procedures for the removal of starch sizes generally use enzymes because, unlike oxidizing agents, this rules out damage to the cotton. The latter are therefore only found in isolated cases, for example in cases where the size contains enzyme poisons.

Persulphate desizing can be used both after the cold dwell process and after the steaming process. In order to avoid fibre damage, max. 0.5% sodium persulphate can be used in the cold dwell process, and no more than 0.2–0.35% (in relation to the material weight) in the steaming process. Application takes place in an alkaline medium. Without the alkali, complete desizing is impossible.

Persulphates: (peroxysulphates, dioxysulphates) Salts of peroxysulphuric acids ($\text{H}_2\text{S}_2\text{O}_8$ Sulphur oxyacids), such as the highly water soluble ammonium, potassium or sodium persulphates. Application: Bleaching and strong oxidizing agent for vat dyeing and printing; desizing agent; bleaching agent for wool, waxes, fats and oils.

Perylene tetracarboxylic acids: It is a group of anthraquinone dyes comes in anthraquinone dyes with a perylene structure and condensation product of 3,4,9,10-perylene tetracarboxylic acid with p-chloroaniline.

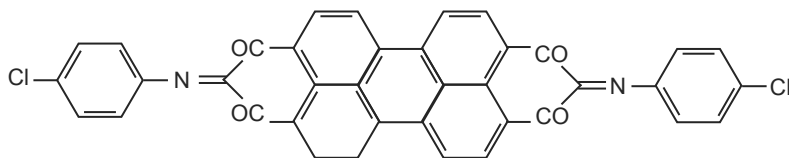

Indanthrene Scarlet R

PES: Polyester.

PET: Often used as an abbreviation for polyester in the Anglo-Saxon language area.

Petersham: (1) Narrow and ribbed belting used for tops or skirts, stiffening waistbands etc. It is in plain weave; the warp is fine and a thick weft gives a warp rib structure. In various widths from 2 to 5 cm. (3/4 to 2 in.) It may be cotton, viscose or polyester, sometimes elastic inserted.

(2) Originally a thick napped overcoating fabric associated with Lord Petersham, but rarely found now.

(3) A heavy woollen, woven or felted kind of cloth for overcoating. It has a rough, knotty surface, and is sometimes called “nigger-head.” A very heavy, close-felted kind of this

cloth is also called “cordington” ; the finer, softer kinds “chinchilla.”

Petticoat: Stiff, dome shaped underskirt, usually layered and decorated worn by ladies in the fifties.

PETP: Polyethylene terephthalate.

Petroleum sulphonates: Petroleum sulphonates are prepared by sulphonation of hydrocarbons; most commercial products are actually byproducts of petroleum refining. In the case of “natural” petroleum sulphonates, they are produced by sulphonation of crude oil fractions. The purpose of the sulphonation is removal of a portion of the aromatics from the oil and the resulting by product/co-product stream is a complex mixture of sulphonated aliphatic and (mainly) aromatic hydrocarbons. To complicate matters, the term petroleum sulphnates is also applied to materials produced by sulphonation of synthetic materials, such as alkylbenzenes (detergent alkylate). In this case, a higher boiling alkylbenzene feedstock is used than for the production of surfactants for household detergents. The products therefore have only limited water solubility.

Petticoat finish: In particular in polyamide and polyester items to achieve a permanent stiffening finish using aminoplasts and/or thermoplastic artificial resins.

PFD: (or pfd): Prepared for dyeing.

PFP: (or pfp) Prepared for printing.

pH: A measure of acidity or alkalinity representing the logarithm of the reciprocal (negative logarithm) of the concentration of hydrogen ions. The pH of the textiles is generally determined on aqueous extract of the textile being tested. A measure of the concentration of hydronium (H^+ , H attached to

a molecule or water) in a solution; $\log[\text{H}^+]$ (that is, the negative base-10 logarithm of the concentration of hydronium) ³ +Acids have pHs less than 7; bases have pHs greater than 7. A pH of 7 is neutral. The normal pH range is 0 to 14. Note that although the pH scale is logarithmic, it does not mean that 10 times as much of a base/acid in solution will increase/decrease the pH by 1 unit. This is true for strong acids and strong *bases*, but is not true for weak acids and weak bases.

pH of fibre extracts: Determination procedure: Fibre samples are leached for 60 min at room temperature in distilled water in a liquor ratio of 1 : 5, 1 : 10, 1 : 20 and 1 : 50 (in polyethylene bottles). The pH of the extracts is measured with a glass electrode and plotted against the associated liquor ratio in a co-ordinate system. The curve obtained is extended to intersect with the pH ordinate. This point is the pH (extrapolated) at a liquor ratio of 1 : 0 and corresponds with the pH of the fibre. It can be determined both graphically and by calculation and is applicable for all fibrous material (for wool only at $\text{pH} < 3$ or > 11).

pH Down: As a spa or swimming pool additive, a chemical to reduce pH. pH Down is almost always sodium bisulfate, which is typically in the form of tiny spherical beads.

pH Up: As a spa or swimming pool additive, a chemical to increase pH. pH Up is usually “pure” sodium carbonate (soda ash). Because it can often be purchased at grocery or hardware stores, usually reasonably cheaply, it may be a good alternative to buying soda ash from a dye vendor. Sometimes sodium bicarbonate is sold for increasing pool pH. It is not equivalent to soda ash.

Phase Change/Discolour textile materials: Phase change textile material reacts to temperature change. It does not respond to a change in body temperature, but when there is a temperature change outside, phase change materials melt or solidify. Discolor material is also known as Chameleon material. It changes colour when exposed to heat.

Phase change materials: A hydrophilic compound applied to a fibre or fabric which results in superior breathability and a moisture management system within the fabric that helps to maintain a comfortable body temperature when the garment is worn.

Phases beam: A beam on which each of the ends is wound from the same depth of each of the bobbins on the creel. Phased beams are prepared when yarn properties vary from the inside to the outside of the bobbins in order to prevent warp streakiness in the finished fabric.

Phase-separation spinning: See **Spinning**.

Phenolic: (1) Containing or pertaining to phenol. (2) A resin or plastic made by the condensation of a phenol with an aldehyde and used particularly in coatings and adhesives.

Phenyl: A chemical radical, (C₆H₅-), derived from benzene. It is the basis of many aromatic derivatives.

Phloroglucinol: 1,3,5 trioxybenzene), C₆H₃(OH)· 2H₂O. White or yellowish crystals, soluble in water, easily soluble in alcohol and ether; reduced Fehling's solution in heat. Application: Detection of lignin and pentose (Phloroglucinol reaction).

Phosphorescence: Emission of light that persists for a noticeable time after the removal of the excitation source.

Phosphoric acid: An inorganic acid having the formula (H₃PO₄).

Phosphorylase: Ferment (magnesium adenylic acid protein), which splits starch into glucose (in test tube also artificial starch structure from glucose), whereby inorganic phosphate is inserted at the dissolved link point of the glucose molecule and splits glucose-I-phosphate.

Photo sensitized degradation of Cellulose: Although light of wavelengths greater than 310 nm cannot degrade cellulose directly, some other compounds such as dyes and some metallic oxides can absorb near-ultraviolet radiation or visible light and in their excited states can induce the degradation of cellulose. These reactions are designated photosensitized degradation but do not have a common mechanism. The photochemical tendering of cotton fabrics containing vat dyes has been recognized for many years. Emphasis has been placed on practical problems involving textile performance rather than on mechanistic studies. It is known that this sensitized deterioration depends on the presence of oxygen in contrast to direct photolysis. The cotton cellulose is also subjected to degradation upon exposure to high-energy radiation. The radiation sources have included cobalt-60, fission products in spent fuel rods, and high voltage electrons generated by linear acceleration. High-energy radiation causes oxidative depolymerization of cellulose in the presence or absence of oxygen to yield hydrogen, one-carbon gaseous products, and multicarbon residues. At low doses, fibrous properties are retained.

Photochromism: Photochromism is generally regarded as the reversible interchange of a single compound between two molecular states, which show different absorption spectra when activated by light. Or in simple words in textile context "the change of colour of a dyeing changes on exposure to light, but reverts to its original state after the sample is kept in the dark. The extent

of this photochromism is expressed as a grey scale assessment given alongside the rating for fastness to light.

Photodegradation: Degradation caused by the absorption of light (particularly ultraviolet light) and consequent chemical reaction.

Photographic printing: See **Printing**. Photographic prints are made similar to that used in making photograph. A negative is placed on the fabric and light is transmitted to it and the design is developed. The fabric is washed and the design is as permanent as a photo.

Photonic clothing: Photonic clothing is a general term for clothing that has an embedded or detachable illuminator and a digital control device emitting light while preserving the characteristics of the conventional clothing. Due to the chemical properties of clothing materials, the existing clothing undergoes varying degrees of fabric discoloration in accordance with temperature and light of the surrounding environment. By contrast, however, the photonic clothing enables wearers to control the degree of illumination with a light-emitting device.

Photonic clothing, colour-changing: This type of photonic clothing has a function that enables the wearer to choose and control colours and patterns of the garment's luminescent part by regulating the mode of light emission on the optical fibres. The application of this comparatively simple function is suitable for functional sports clothing and safety garments.

Photonic clothing, colour-responding: These are garments that are the kind of photonic clothing with colours that automatically vary with surrounding colours or that allow wearers to adjust them as they please. The photonic clothing with colour recognition capabilities consists of a bare garment made of optical fibre and other fibres, a colour sensor that perceives colours surrounding the clothing, RGB LED that emits light of colour recognized at the optical fibre end point, and a colour control module. Colours that the wearer inputs with the colour sensor change to colours similar to what the optical fibre of the photonic clothing has sensed.

Photonic clothing, sound-responding: It is a kind of smart clothing capable of changing colours or light emission amount by reacting to external vibration or sound. Smart clothing adjustable to external vibration consists of a bare garment made of optical fibre and other fibres, a vibration sensor that perceives vibration external to the clothes, and a colour light control module that adjusts light emission of RGB LED to correspond to the level of vibration sensed on the optical fibre end point. In an environment such as a club where music is present, the wearers are able to experience various effects, with the area and

the size of their garment's luminescent parts made to change according to the loudness of external sound.

Photosensitive coatings: Photosensitive coatings are increasingly competing with chrome gelatine in the manufacture of screen printing screens. These coatings mainly use Polyvinyl alcohol which has been sensitized using chromium salts. Such photosensitive coatings have better adherence, contain no water soluble components when illuminated and always have sharp, unchanging contours. The screens are coated cold, in daylight. It should be noted that these coatings require slightly longer illumination times.

Photosensitive coating of screens: Layer of photosensitive lacquer applied to the gauze during the manufacture of screen printing templates, which hardens due to the effect of light.

Photosensitive lacquer: Forms the basis for the creation of printing screens, because once illuminated it takes on lacquer-like solidity and resistance, i.e. after illumination no further reinforcement is necessary (Positive process for screen making).

Photosensitive layers: Photosensitive layers are used in screen making. One of the methods of screen making, water soluble photosensitive layers are coated on the screen or bolting cloth and exposed to light with the design on a transparent sheet covering them. On exposure, the portion where light has fallen water-insoluble compounds (e.g. chrome gelatine) are formed. On washing the unexposed portion, where the photosensitive layer remains water soluble are washed off and the design is exposed on the screen.

Phototropism: (Gk.), colour change due to UV light. Occurs if the dye reflects the UV part of daylight with longer wavelengths than that of visible light. This can be caused by after-treatments, such as anti-crease finishing, chintz finishing, etc. The normal shade generally only returns after long periods in the dark or when the material is irradiated with red light. See **Photochromism**.

Phthaleins: Dyes derived from xanthene or triphenylmethane-carboxylic Acid. Typical representatives are phenolphthalein, fluorescein, eosin.

Phthalic acid: An organic acid obtained by oxidation of various benzene derivatives and having two adjacent (ortho) acid (COOH) groups on the benzene ring.

Phthalocyanine dyes: The term phthalocyanine was first used by R. P. Linstead in 1933 [1] to describe a class of organic dyes, whose colours range from reddish blue to yellowish green. The name phthalocyanine originates from the Greek terms *naphtha* for mineral oil and *cyanine* for dark blue. In

1930–1940, Linstead et al. elucidated the structure of phthalocyanine (H₂Pc) and its metal complexes.

Phulkari: (Literally means flower work) Dazzling drapes worked with the darning stitch, were traditionally embroidered by women in the Punjab and Haryana in India, to be gifted to their daughters and daughter-in-law at weddings, ceremonies and festivals. See also **Bagh**.

Physical finishes: Physical finishing methods for textiles include optical finishing, brushing and napping, softening, shearing, and compacting of the textile structure.

Piassava fibre: Palm fibres (Africa, Brazil) for mats, brushes, brooms, ropes, braiding, also stiff fabric. Light to dark coloured, containing silicic acid. Dyeing properties similar to coir.

Pick (n): (a) A single operation of the weft-insertion mechanism in weaving. (b) One or more weft threads inserted between successive beat-ups. See **Beating-up**.

Pick (v): To pass the weft through the warp shed in weaving. See **Picking**.

Pick: An individual weft yarn.

Pick: The number of threads within a given space.

Pick bar: A bar in which the pick spacing is different from that in the normal cloth This is a general term which covers no. of specific faults like starting place, weaving.

Pick count, in woven fabrics: The number of filling/weft yarn per inch of the fabric.

Pick counter: (1) A mechanical device that counts the picks as they are inserted during weaving. (2) A mechanical device equipped with a magnifying glass used for counting picks (and/or ends) in finished fabrics.

Pick glass: See **Pick Counter, Piece Glass**.

Pick-up: Quantity of any liquor taken up by the substrate in any process. It is expressed in percentage of the dry weight of the substrate .

Pick up place: See **Temple mark**.

Pick-out mark: (1) A weftwise band or bar characterised by a chafed or fuzzy appearance due to the pulling out of the original picks.

(2) A filling wise band or bar characterized by a chafed or fuzzy appearance due to pulled-out picks.

Pick-out place: (1) See **Temple mark**.

(2) A place in the woven Fabric where the pick is missing.

Pick-and-pick: A woven fabric with alternate picks of yarns of two different colours or kinds

Picker: (1) A machine that opens staple fibre and forms a lap for the carding process used in the production of spun yarns. (2) That part of the picking mechanism of the loom that actually strikes the shuttle. (3) A mechanical device used to open fleece before carding. The swing picker looks, for all the world, out of something from an Edgar Allen Poe horror story. Not recommended for the faint-of-heart, children, or those who don't pay attention.

Picker lap: A continuous, considerably compressed sheet of staple that is delivered by the picker and wound into a cylindrical package. It is used to feed the card.

Picker sticks: The two sticks that throw the shuttles from box to box at each end of the brace plate of the loom.

Picking: (1) The second of the three basic motions in weaving, in which the weft is passed through the warp shed. As the harnesses raise the heddles or healds, which raise the warp yarns, the shed is created. The filling yarn is inserted through the shed by a small carrier device called a shuttle. The shuttle is normally pointed at both ends to allow easier passage through the shed. In a traditional shuttle loom the weft or filling yarn is wound onto a quill and mounted inside a shuttle. The filling yarn emerges through a hole in the shuttle as it moves across the loom. A single crossing of the shuttle from one side of the loom to the other side is known as a pick. As the shuttle moves back and forth across the shed it weaves an edge or selvage on each side of the fabric which prevents the fabric from ravelling.

(2) The rectification of the face and the back of a carpet after manufacture, including insertion of missing tufts, replacement of incorrect ones and repair of broken yarns in the backing (local mending).

(3) A process carried out before the final stage of fabric finishing to remove, by hand, any contamination (such as kemp (see kemp fibres), wrong fibre, coloured hair, etc.) that has not been removed by previous processing. NOTE: This process is carried out in particular during the finishing of suitings, face-finished fabrics and cream or off-white fabrics.

Picking order: The smallest number of picks in colour and/or count that repeats up and down the fabric.

Picklock wool: A term used in wool sorting mainly in UK for the second best sorts from the fleeces.

Picks per inch, finished: Number of picks per inch on the finished woven fabric.

Picks per inch, in loom: Number of picks per in the loom state woven fabric.

Picks per inich, in grey: Number of picks per inch on a grey woven fabric.

Picolay: Compact cotton fabric with a plain weave, embossed with a diamond pattern to resemble diamond pique. Used for childrens clothes, table cloths.

Picot: The term is used to describe a loop edge. This may be found on many types of lace and edgings.

Picot: (1) A small loop woven on the edge of ribbon, or a purl on lace. A picot edge may also be produced by a hemstitching machine. (2) A run-resistant loop usually found at the top of hosiery.

Pictorial and figurative designs: Designs featuring visual representation of objects, people and animals.

PID control: (Proportional-Integral-Differential), generally valid temperature control principle that uses an additional measuring device to rule out variations in temperature control due to the delayed response of the control elements and guarantee an optimal constant temperature.

Piece: A standard length of a fabric, such as 40, 60, 80, or 100 yards.

Piece dyed fabric: Basically means a dyed fabric, which fabric is dyed in the fabric form, i.e., after weaving.

Piece dyeing: (1) See **Dyeing**. The process of dyeing a fabric after weaving. (2) A section in the processing department where the fabric is dyed in piece form.

Piece dyeing machines: (1) (with fabric movement) The following general principle applies: the piece goods move, whilst the liquor remains stationary; for example Winch beck, Jigger, Padder, Jet dyeing machines, Overflow dyeing machines. However, a clear demarcation of this type cannot be made. In jet dyeing machines, for example, both the material and the liquor are in motion.

(2) (with liquor movement) The following general principle applies: The liquor moves and the item to be dyed remains stationary; for example: HT beam dyeing machines; Star frames. Only the discontinuous working mode is possible.

Piece glass: (pick counter). A magnifying glass with horizontal and vertical measuring scales for determining the yarn count (woven fabrics) or stitch density (knitted fabrics).

Piece goods: See **Piece**.

Piece-dyed goods: A piece of standard length after dyeing.

Piecing: A thick place in a spun yarn caused by poor splicing.

Piecing: See **Slug**.

Piecing: The joining of two or more ends of sliver, roving, yarn, etc.

Pied de poule: See **Check pattern fabric**.

Piecing out: The act of sewing together the pieces, which sometimes occur in the facings of garments, is called “piecing them out.” “Dograbbing.”

Pierced Cocoons: Cocoon from which the moth have been allowed to emerge so that they mate and produce eggs.

Pigment: A coloured substance that is insoluble in water, usually in the form of a fine powder. Pigments are used to colour many types of paint, including some textile paints, and almost all “inks” used for screen printing (“silkscreen” printing). Pigments need some sort of binder to hold them onto fabric. Azoic dyes and vat dyes actually form pigment inside fibres. These pigments are physically trapped inside the fibre, so no binder is necessary. Inorganic pigments are often oxides of metals, such as iron oxide or titanium dioxide. Many organic pigments are chemically similar to parts of dye molecules, but lack the necessary features to make them soluble and to bond, unaided, to the fibre.

Pigment, leafing (Bronze): So called leaf forming ‘fat rich pigments’ which float on liquid surface and orientate to give a highly reflecting film.

Pigment, non leafing (Non-Bronze): ‘Low fat’ pigments which are completely wetted out and therefore do not float but orientate within the binder film.

Pigment dyeing: (1) Colouring fabric with pigments mixed with a binder; this term is considered to be improper, since ‘dyeing’ is generally restricted to application of colorants that are soluble, and pigments are insoluble. Some pigment application processes are much like dipping the fabric in a dilute paint. Newer processes involve pretreating the fabric with substantivity-producing agents that actually make the process more like true dyeing, where the pigment preferentially leaves the bath and attaches to the treated fabric. So-called pigment dyed fabrics often have, by design, poor wash fastness, to produce an aged appearance. Commercially, pigment dyeing is generally used more for finished garments than for fabrics.

(2) In terms of procedure it resembles the classic proofing process with pad-dye impregnating, drying and curing. The pigment dyeing process makes use of water-insoluble pigment dyes of either inorganic or organic nature which

are fixed to the fibres with the aid of a fixing agent. Since no affinity between fibre and dyestuff is involved, dyeing can be carried out on all fibres and fibre blends.

Pigment dyeing Process: The dye is padded, the material is dried and heat set. After-treatment is not necessary. Good fastness. Wash fastness depends upon the binder and not the dye. Suitable pretreatment necessary to create good absorbency, as are faultlessly functioning padder and drier (dye migration). Only light shades and possibly some medium shades are possible because the rubbing fastness is insufficient in darker shades. The pigment dyeing process is suitable for all natural and synthetic fibres and is used primarily for cheap qualities.

Pigment printing: Printing technique based upon a system of pigment and binder. Water insoluble white or coloured pigments with no fibre affinity are fixed to the textile material using synthetic resin binders. It differs from normal printing in that the dye is present in the form of insoluble bodies with no affinity to the substrate. See **Printing**.

Pigment tafetta: The only taffeta fabric without shine. Dull pigmented yarns lacking lustre used but the fibres are usually silk or manmade.

Pigmentation process of vat dyeing: In a package dyeing machine, for example, these distribute the non-vatted dye first, in order to then make it soluble at the end of the exhaustion phase in the form of pigment adsorbed on the fibre surface. Normally the following procedure is followed for vat dyeing: Pre-vatting in the liquor.

Pigmented yarn: A dull or coloured yarn spun from a solution or melt containing a pigment. (Also see **DYEING, Mass-Coloured**.)

Pigmenting process, in solvent technology: Breaking down of insoluble product additives into pigments, using mechanical pressure, they are then removed mechanically, for instance by after-print cleaning (polyester, polyamide, triacetate weaves and knits). For fixed prints a high pressure tetrachloroethylene liquor jet is applied, causing insoluble (acrylate) films (print thickeners and synthetic sizes) to be broken down into pigments, which, in an insoluble state, are washed off and flushed away as unfixed print dye residues. Operating speeds in solvent continuous technology are > 50m/min. The print thickeners or sizes accumulate with dye in the form of a thick solvent-free sludge, which is disposed of as hazardous waste.

Pigskin: This is easily recognised by the little holes or pores where once the bristles of pigs grew. Very hard wearing. Used for gloves, coats, belts, handbags etc.

Pilate: A deprecated term, see preferred term **Pile lifting**.

Pile, in pile fabrics: The raised loops or tufts (cut loops) that form all or part of the surface.

Pile, in carpet: That part of a carpet consisting of textile yarns or fibres, cut or looped projecting from the substrate and acting as use-surface.

Pile: (1) A fabric effect formed by introducing tufts, loops, or other erect yarns on all or part of the fabric surface. Types are warp, filling, and knotted pile, or loops produced by weaving an extra set of yarns over wires that are then drawn out of the fabric. Plain wires leave uncut loops; wires with a razor-like blade produce a cut-pile surface. Pile fabric can also be made by producing a double-cloth structure woven face to face, with an extra set of yarn interlacing with each cloth alternately. The two fabrics are cut apart by a traversing knife, producing two fabrics with a cut-pile face. Pile should not be confused with nap. Corduroys are another type of pile fabric, where long filling floats on the surface are slit, causing the pile to stand erect. (2) In carpets, pile refers to the face yarn, as opposed to backing or support yarn. Pile carpets are produced by either tufting or weaving. (Also see **Cut pile** and **Loop pile**.)

Pile Bursting: The appearance of a cut pile of a carpet achieved by different process producing a volume of apparently greater than that which was occupied before the application of this process.

Pile Carpets: See **Carpet, pile** Carpets with pile or Pile layer (pile loops), in the form of knotted carpets, tufted carpets, or woven carpets; Axminster carpets; Bouclé carpets; Brussels carpets; Chenille, Plush carpet; Tapestry carpet; Tournay carpet; Velvet carpet.

Pile carpet woven over wires: Pile carpet produced in a single operation on a loom in which steel rods are used to form the pile and to determine its length.

Pile Crush: The bending of upholstery or carpet pile that results from heavy use or the pressure of furniture.

Pile Cutting Machine: Special form within the group of Shearing machine. Whilst classical shearing machines always cut in several passes, new models make only a single shearing passage. Long pile items are cut to the desired pile height in a single stage. This makes it possible to economically reuse the cut off fibres.

Pile Lifting Machine: A machine used for the Shearing of fabrics for the alignment of the pile or fibres to be sheared.

Pile Fabric: Any cloth of any fibre that has a raised surface if individual fibres, making a furry surface. Pile may be uncut in manufacture, e.g., terry toweling, or cut, e.g., Velour. The direction of the pile on the cloth may be felt

or it can sometimes be observed by holding the length of the cloth vertically. Where the pile is running upwards, the cloth will look a different shade from where it is running downwards. The cloth can be made with the pile running in either direction.

Pile firmness: See **Knops resistance**.

Pile floor covering: A pile fabric intended for use as a floor covering. The pile may be in the form of cut loops or loops or both. Either cut loops or loops may vary in height.

Pile formation: Undesired phenomenon in velour materials, particularly carpets. Pile fibres lie to one or other side in patches, giving rise to a blotchy appearance on the surface of the velour.

Pile height: A measurement that uses a small graduated ruler inserted until it touches the backing to measure the pile from the top surface of the primary backing to the top of the tuft.

Pile height, effective: See **Pile length, effective**.

Pile knit: Any fabric with a knitted construction as the base and a lopped or cut pile on the surface. Examples are stretch toweling, Jersey velour.

Pile knitted fabric: Manufactured according to the type of Plush cloth with pile surface, i.e. cut/ shorn, pile quite short up to 14 cm long. Application for lining fabrics, outer cloth, imitation fur, blankets etc.

Pile lay, in floor covering: The direction in which most of the pile fibres lean in the original, uncrushed carpet.

Pile layer: Wear layer in carpet material which contains an additional pile forming material above a special Carpet primary backing.

Pile length, effective, in carpet: The length of the fibre or one leg of a tuft from the place where it emerges from the substrate to its farthest extremity or half the length of a loop measured between the two points where it emerges from the substrate.

Pile lifter: Used in carpet shearing machines, for example, for aligning each pile row for shearing using a pile lifting roller fitted with special needles.

Pile lifting: The process of raising the pile on a textile.

Pile lofting: See preferred term Pile lifting.

Pile lifting machine: Pile lifting machine is used in the Shearing of fabrics for the alignment of the pile or fibres to be sheared.

Pile loops: (1) In pile fabric systems that have closed or cut open yarn loops, typically for Pile carpets. (2) Thread sections of the Pile warp between the cutting/untying or bonding points. Knops.

Pile mass above bacing: The mass of the pile that can be shorn or cut.

Pile mass per unit area: The mass of the pile yarn in the given area including that forming the base of the tufts or held in the backing.

Pile opening: With the aid of a pile opening machine pile threads, which are usually made of twisted yarns, are gently opened in wool plush items, for example. The material is processed wet to minimize the material loss.

Pile patterning: The surface of pile fabrics or pile knitted goods can be patterned using different methods: – stencil brush– whirling brush– partitioned shearing tables, which are rotatable and driven.

Pile rake: A hand tool with smooth circular plastic tines used for pile lifting.

Pile reversal: A persistent change in the direction of pile lay in certain areas, resulting in an apparent visual difference of shade.

Pile root, in carpet: That part of the tuft and or loop, excluding dead yarns which is in the substrate.

Pile thickness, pile yarn floor covering: The difference in the unextended height of the tuft elements above the backing measured as the difference between two parallel plates exerting a specified compression on the pile and the backing and on the backing with the pile removed.

Pile thickness (Effective): The difference in the thickness of carpet before and after the pile above has been shorn away.

Pile thread: Yarns forming the characteristic pile in Velvet or Plush fabrics. This is done by placing the threads placed across thin metal rods (pile wires) during weaving, which are subsequently pulled out, creating loops over the base fabric, which can also be cut open. If the pile yarn is a warp thread this creates warp velvet; if it is a weft thread it creates weft velvet.

Pile volume ratio: Ratio of the actual volume of the pile-forming fibres above the substrate to the total volume of the effective pile.

Pile warp: Warp ends for the creation of the Pile layer and its bonding into the Carpet primary backing.

Pile weave: Pile fabrics are formed by having the basic plain or twill weave as a backing and a third yarn is woven to yield a surface pile. The pile may be warp pile or weft pile. For making ground fabric, plain or twill weave is used, the extra set of filling yarn floats over three or more warp yarns. The floats are cut and brushed up to form pile. This is called filling pile. Examples are

velveteen and corduroy fabrics. If an extra warp yarn floats over the filling yarn, it is called warp pile. Examples are velvet, velour and rug velvet.

Pile weight: (1) Weight in grams of the pile yarn processed per m² of carpet. (2) Weight in g/m² of the pile material protruding above the carpet base; determined by shearing (shaving) the pile.

Pile wire: A metal rod over which yarn is woven to generate a pile fabric.

Pile yarn floor covering: A textile product in which yarn or yarn segments are attached intermittently to a backing fabric to project above the backing fabric and form a pile, in the form of cut loops, or both, with the yarn entering the backing fabric substantially perpendicular to the plain of the backing fabric.

Pile yarns: Threads in Velvet or Plush, which form the characteristic pile. This occurs by threads being placed across thin metal rods (pile wires) during weaving, which are subsequently pulled out, creating loops over the base fabric, which can also be cut open. If the pile yarn is a warp thread this creates warp velvet; if it is a weft thread it creates weft velvet.

Pile yarn mass, for back coated pile yarn floor covering: The mass per unit area of pile yarn.

Pile, carved: The pile of a carpet in which, after manufacture is subjected to a shearing operation with the object of creating different levels of pile, in general on the periphery of certain elements or designs formed by the pile.

Pile, curled: The pile of a carpet, in which curl has been induced in the pile yarn by over twist or by other means.

Pile, cut: The pile of a carpet consisting of legs or tufts or individual fibres.

Pile, cut loop: The pile of a carpet formed during the manufacture by loops and tufts of different lengths or of the same length loop pile.

Pile, sculptured: A pile in which a pattern is created by having areas of different lengths of pile and/ or by omitting pile in certain areas.

Pile, textured: A pile in which the surface character is varied. E.g. by having areas of different characteristics or by a combination of different yarn or pile types. E.g. Soft and hard twist etc.

Pile, tip-sheared: The pile of a carpet originally consisting of loops of different lengths, which has been subjected after manufacture to a shearing process to cut the tips of the longer pile loops.

Pile, uncut: The pile of a carpet consisting of loops.

Pills: Bunches or balls of tangled fibres which are held to the surface of a fabric by one or more fibres.

Pill: A small accumulation of fibres on the surface of a fabric. Pills, which can develop during wear, are held to the fabric by an entanglement with surface fibres of the material, and are usually composed of the same fibres from which the fabric is made.

Pill build-Up: The pills which are formed on the surface of a fabric due to abrasion, wear etc, are in the form of small balls. This on further wear will cause pulling put more fibres from the body of the fabric and the pills will grow bigger and bigger. This phenomenon is called pile build up. After a certain size, as per the fibre type, this pills will fall off as the fibre connecting the pill and body of fabric can no longer hold them.

Pill formation: Synthetic fibre fabrics and its blends have got a tendency of forming small balls due to entanglement of the fibres on abrasion and wear of the garment. This process of ball formation is called pill formation.

Pill Test: Method for testing the burning behaviour of carpets. A methenamine pill is ignited upon the test piece and the combustion effects evaluated.

Pillar stitch, in warp knitting: See warp knitting. Chains of loops in unconnected wales are produced. They must be connected together by yarns supplied for a second guidebar.

Pillar Stitch: So-called single chain stitch seam, in which all stitches consist of one thread system and are easy to undo again, e.g. as decorative stitching and as piece goods sewing.



Pilling: (pills, from the Lat. pila = hair balls), faulty, knop-like places that arise at points on clothing that are subject to particular wear due to the undesired rolling together of fibre ends on the surface of the fabric. It gives rise to a rough material surface (pilling effect) which is virtually impossible to dye uniformly. Most common on mixed fabrics and knitted goods made of wool with synthetics (polyamide, polyester or polyacrylonitrile fibres), also in pure synthetics.

Pilling Test: See **Pill Test**.

Pilling resistance: Resistance to the formation of pills on a textile fabric.

Pillow lace: See **Lace, bobbin**.

Pills: Bunches or balls of tangled fibres that are held to the surface of the fabric or yarn by one or more fibres.

Pilot: A woollen cloth generally made in navy blue and used for seamen's coats. It is usually a heavily milled 2/2 twill with a raised, brushed finish.

Pin check, Pinhead, Pick and Pick: Made of worsted, also made in cotton and rayon. A minute check effect caused by a combination of weave and colour. It has the appearance of tiny white dots appearing in rows, vertically, and horizontally. Holds a sharp crease, tailors and wears exceptionally well. In time, it is inclined to shine with wear. A cheaper imitation is made from viscose but this is not hard wearing. Used for men's suitings, women's skirts. In cotton, it usually has a white dot on a blue ground and it is used for work clothes.

Pin clips: See **Clips**.

Pin cord: A very fine needle cord fabric.

Pin drafting: Any system of drafting in which the orientation of the fibres relative to one another in the sliver is controlled by pins.

Pin holes, in fabrics: A very small hole approximately the size of the cross section of a pin, formed due to the breakage of the yarn by mechanical or chemical action.

Pin lock slider, in Zipper: A slider that incorporates a projection on the pull that fits between adjacent interlocking elements of a zipper when a pinlock slider is in the locked position.

Pin locking, in Zippers: Projection on a pull that fits between adjacent scoops of a fastener when a pin lock slider is in the lock position.

Pin mark: A series of holes near the edge parallel with the lengthwise direction of a fabric caused by the holding device on a pin stenter frame. See also **Clip Mark**.

Pin retainer, in Zipper: A tubelike element similar to the separable pin attached over the bead at the bottom end of the stringer opposite to the separable pin. This element is designed to hold the fixed retainer in position.

Pin stripes: The name given to any cloth with very fine pin-width stripes. Usually associated with men's worsted suitings.

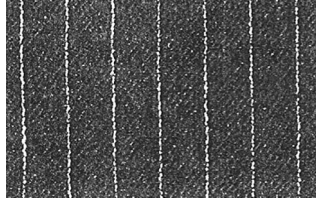

Pin Tucks: Tiny lines of pleats that are stitched down. They can be any distance apart and are purely decorative. They are seen on shirts, blouses, skirts etc., usually on lightweight fabrics.

Pin, Separable, in Zippers: A tube like element attached over the bead at the bottom side of the stringer.

Pin-wale corduroy: See **Corduroy**.

Pin-drafting: A system of drafting in which the fibres are oriented relative to one another in the sliver and are controlled by rolls of pins between the drafting rolls. It is primarily used for long fibres in the semi-worsted and worsted spinning systems.

Pina: The vegetable leaf fibre from the pineapple plant.

Pina cloth: A fine plain woven cloth for which the yarns are produced from the fibres of the leaves of the pineapple plant. It is a stiff wiry fabric and makes a good base for embroidery.

Pineapple cone: Biconical package, conical with spherical face. Crosswound yarn package.

Pineapple fibre: A fibre obtained from the leaves of the plant *Ananas comosus*, capable of being processed into fine fabrics.

Pineapple fibre: (pineapple leaf fibre) *Bromelia* fibres.

Pineapple leaf fibre: See **Bromelia fibres**.

Pinhead: A small pinhead-sized opening usually found about 10 to 12 inches from a selvage.

Pinheads usually run in a fairly straight line along the warp and are formed by the shuttle pinching the filling, causing small kinks that show up as small holes in transmitted light.

Pinhole: A very small hole in hosiery or woven fabric.

Pinion barré: A fine, filling wise fabric defect appearing as one or two pick bars in an even repeat. It is caused by a faulty loom pinion.

Pinked seam finish: Pinking a seam edge is only a ravelling stop gap which works best on firmly woven fabrics. You will need a sharp pair of pinking

shears for this seam finish. Pink just on the edge of the seam allowance, taking short even strokes.

Pinking: Sewing of a material either to prevent fraying or to decorate at the raw edge.

Pinning: On a Pin Stenter there are two pin chains on to which fabrics are pinned at both selvages and carried through the stenter chambers for drying, finishing or heat setting of the fabric etc. At the entry of the stenter there is a pinning mechanism to pin the fabric at the selvages exactly.

Pint: A volume measure equal to half a quart; in the US, 1 pint is equal to 16 fluid ounces, in Canada and Britain, pint equals 20 fluid ounces.

Pinwale: A very narrow wale or rib in corduroy. Also written pin wale.

Piping: (1) A strip of material with or without a filling applied folded, normally to the edge of a garment. (2) A narrow fabric having a cord on one edge. (3) The operation of applying piping on a fabric.

Pique: Originally piques were fabrics with cords in the weft direction. As it is undesirable to weave cloth with cords in the weft direction today nobody makes pique of the old name. Today pique is a cloth of fine Bedford cord construction. A weave of real pique is rather complicated. It has two warps: A face warp and a backing warp, usually in a proportion of two ends of face to 1 end back. It has 3 wefts: a face weft which forms the surface of the cords; a cutting filling which forms the grooves between the cords; a coarse stuffer weft which is held between the backing warp and the face warp, under the face warp, to accentuate the cords. An average construction is 100 x 160 with 30s for the face warp and 2/30s for the back warp, 30 for face and cutting weft and 10s for the stuffer. In case of Bedford cord pique, a typical construction can be 150 x 80 with 40s warp and 20s stuffer and 40s filling. Besides Bedford cords there are other pique derivatives. Pique (Fr: stepped), the characteristic stepped property is a result of the weave, sometimes also by an embossing treatment. Genuine piqué (fur piqué) consists of a fine plain weave top cloth

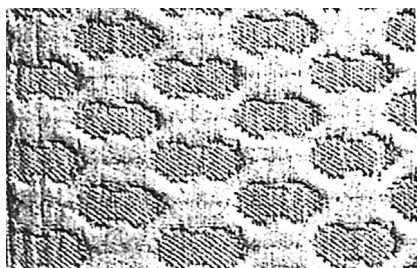

Pique

and a coarse back cloth. The effect is created by filling and figuring wefts made of thick material and bound according to a pattern, which imprint onto the fine threaded surface to form the embossed pattern. In double piqué the material has two right sides. In press piqué, a non-genuine piqué, the figuring pattern is pressed into the smooth fabric by the embossing calender; often made durable by a special synthetic resin finish. Once always made in cotton and in white, but now small amount of other fibres may be used. Piqued fabric can also be made from other fibres also. Cotton pique is stiff and absorbent. Used for tennis clothes, it is hard wearing.

Pique Anglais: Solid coloured French serge, having eight leaves and eight picks in a repeat.

Pique' voile: See **Voile**.

Pique, fast-back: Refer *Loose-back pique*. In case of a construction with four shafts one may weave in to the stitching warp, and this is called a fast; back pique.

Pique, loose-back: Simple pique has horizontal ridges that run from selvedge to selvedge. The first two shafts are alternated to start the plain weave, and then a soft squishy wadding weft that will not show on the face is inserted under the face warps and over the stitching warps. The wadding pick is inserted halfway through the weaving of the face fabric, which positions it nicely in the centre of the cord. The stitching warps float on the back of the fabric. With three shafts this is the only option. This structure is called a loose-back pique.

Piquete: Corded twilled French vesting, made with eight warps and four picks in a repeat.

Piramides: 17th century fine and narrow English worsted, made with two-coloured yarns.

Piripiri: Fine stem fibre of the *Pipturus argenteus* in Tahiti; used for cords, nets and bags.

Pirl: Gold or silver thread made spiral by winding.

Pirle: An English finishing process, rendering the woollen fabrics waterproof and unshrinkable.

Pirn: (1) A support slightly tapered with or without a conical base on which yarn is wound for use as weft. (2) A single-headed bobbin with cone shaped head and barrel 'which varies in length. The pirn is the yarn-supply for the shuttle used in weaving.. (3) Short or long package, with or without cone, primarily for filling yarn.

Pirn barré: A fabric defect consisting of crosswise bars caused by unequal shrinkage of the filling yarn from different points on the original yarn package.

Pishteh: In the Bible means flax and linen.

Pita: Very long, strong, glossy, white and silky fibre, yielded by the various agaves and pineapples in Central America. Used for threads, fine hammocks, etc.

Pitch: The balanced insertion of sleeves into the garment, controlled by balance marks in the scye line.

Pitch, in woven pile floor covering: The number of pile yarn end in 27" measured in the weft wise direction.

Pitch, rope: The distance parallel to the axis of a rope in which a strand makes one complete spiral.

Pitch: See **Gauge**.

Pitch, for pile floor covering: The number of binding sites in 686 mm (27 in.) of width.

Pittman: Commercial variety of early maturing and prolific cotton from Louisiana, the staple measuring 23-25 millimeters; the yield is about 31 per cent.

Pixel: A tiny picture element that contains red, green, and blue information for colour rendering on a monitor or a scanner. When generating colours, pixels are similar to dots of ink on paper. A monitor resolution description in terms of pixels-per-inch (ppi) is similar to a printer resolution description in terms of dots-per-inch (dpi).

pK value: Is the pH at which a compound splits off a proton by the addition of alkali or attaches a proton by the addition of acid. Plays a role in reactions of amino acid side chains of wool. For example, if the pK_S value of per acetic acid lies at pH 8.2; at this pH there are the same concentrations of per acetic acids and per acetate anions.

PKN: Polish standards association Technical and professional organizations.

PKS bleach Process: (peroxide continuous fast process), the continuous immersion bleach process without a padder is suitable for the bleaching of all cotton, cotton mix and linen fabric as well as coloured fabric, particularly where relatively high demands are made of the material quality, such as good absorbency.

PL: Polyester fibres.

Placarder: French term for a resist dyeing process by which the ground will take the dye but the pattern remains white.

Placket: An opening provided in a garment or an extra piece material applied to that opening for reinforcement or as a style feature which may incorporate fastening.

Placket, Tape faced: The tape faced placket is stronger and may be used in children's drawers, etc., in place of a gusset to strengthen the end of the opening. A single piece of tape folded back as for a loop is stitched along all edges, making an opening without a lap. This offers as much resistance as a gusset and is more quickly done.

Placket, Faced: In a third kind of placket, the opening is faced with a continuous piece of tape on both sides and finished with a piece of material on the outside. See illustration. This makes a strong and simple placket. When a tape cannot be used, a hem or facing may be made on the under side of the opening and a facing on the upper side, over which the on-set piece is stitched. The on-set piece and facing may be cut from one piece, but the fitting is more troublesome. In figured goods, the piece set on should match the pattern exactly.

Plagae: Linen sheeting in ancient Rome.

Plaid: Plaids are basically in a checked design, either square or rectangular. The checks are often simple, sometimes produced by only two or three colours. The word plaid was originally used only for the Scottish tartan shawl worn by Highland women of U.K..

Plain curved seam: This is a basic plain seam but curved as is required when stitching the outside edge of rounded collars or cuffs and when applying facings to curved armhole and neckline edges.

Plain dyed fabric: Single coloured, unpatterned.

Plain fabric: Manufactured in plain weave, (usually) smooth material made of flax or cotton of different fineness, density and finish (the finest plain fabric = batiste).

Plain fabric, Weft knitted: A fabric in which all the component loops are of the same sort and meshed in the same manner. The fabric may also be described as a plain single jersey web or stockinet. The appearance may be described with reference to the surface of the structure (a) face; Technical face: The surface of a plain weft knitted fabric that consists wholly of face loops (b) Back; technical back: the surface of a plain weft knitted fabric that consists wholly of back loops.

Plain Gauze: Leno weave where the warp threads cross other warps always in the same direction.

Plain net (Bobbinet): On the plain net or bobbinet machine a series of pairs of thread carriers (bobbins) swing backwards and forwards through the warp sheet whilst progressing from one side of the machine to the other, and back again. The bobbin yarns are thus looped around the war yarns in a spiral formation leaving a regular series of holes in the fabric, in honey comb effect. The machines can be provided with jacquard mechanisms for figuring and pattern threads can be provided in the warp. Patterns also can also be applied on plain net fabric by subsequent embroidery. Applications: veils, laces, drapes etc.

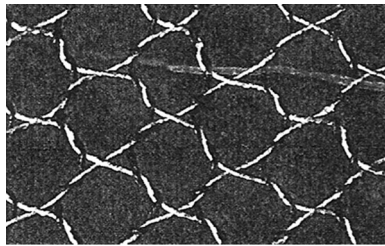

Plain net (Bobbinet)

Palin knit fabric: See **Flat knit fabric**. Single jersey fabric with all face loops on one side and all reverse loops on the other.

Plain loom: Loom used for weaving plain weave, with no attachment for designs, pattern, checks etc.

Plain princess seam: A princess seam is a seam with opposing curves; one seam edge curves out and the other one curves in.

Plain raschel fabric: Raschel-knitted fabrics, in which a guide bar forms the base and a further guide bar inserts a weft in accordance with the pattern, which achieves the side connection of the stitch wales (e.g. weft pattern).

Plain satin: See **Satin**.

Plain seam: A basic seam formed by a single joining line. A seam formed by a row or rows of stitches joining two pieces of materials together face to face. This is the workhorse seam of clothing construction, usually of 10 to 12 stitches per 2.5 cm. (per 1 in.). (a) *Straight:* This is the most common seam used to sew two pieces of fabric together the length of the stitch is between ten to twelve stitches per inch. The width of seam for fashion sewing is usually 5/8 inch and usually 1/2 inch for industry sewing. (b) *Bias Seam:* Hand-tuck bias seams, leaving the threads loose at the ends. Allow your work to hang overnight before stitching. Always use a shorter stitch length for a bias seam Fabric requires a 2 mm (12) stitch length on a straight seam requires a 1.5

mm (15) stitch length on a bias seam to increase the elasticity of the seam. Stitch with the grain. Bias seams are given on a garment as a style line such as while joining 'v' shaped yokes. In the bodice or in case of 'v' shaped skirt yokes. Bias seams can be given in the form of decorative tucks & seams on a garment. (c) (i) *Curved*: Curved seams are quite commonly used when sewing together a garment. In many cases, the curved seam is the style line of the garment, such as princess seams, bodice yokes or skirt yokes. (d) (ii) *Right-Angle Seam or Corner Turns*: This seam with a 90-degree angle usually found in a style line. The sewing method used to turn a corner can be applied to any angular seam found on many parts of a garment. (e) *Double-Stitched Seam*: Use this seam is sheer fabrics and lace for curved as well as straight seams. Place the first row of stitching on the seamline. Press. Place the second row of stitching within the seam allowance, about .6 cm (1.4 inch) from the first row, using a fine multi-stitch zig-zag. Straight stitching may also be used. Trim the seam allowance. (f) *Lapped Seam*: Use lapped seams when joining sections of interfacing and interlining to eliminate bulk. Lap one edge over the other, with the seam lines meeting in the center. Stitch through the center, using a multi-stitch zigzag or straight stitching. If the seam edges are too wide, trim after stitching. (g) *Lapped seam*: This seam is most often used for yokes & applied parts such as gussets. One section is lapped over the other & topstitched. Fold under the seam allowance on the section to be lapped & press flat. Place the sections together right sides up, matching the fold to the seam line accurately & baste in position. Stitch close to the folded edge through all thickness. (h) *Double seam*: For Double top seam, place a row of seam parallel to the first row of top seam, a pressure foot distance away from it towards the same side. (i) *Abutted Seam*: Use an abutted seam for non-woven interfacings and interfacings of hair canvas. Lawn and similar fabrics. Trim away the seam allowance on both sections. Bring the two edges together and pin over an underlay of a lightweight fabric the underlay should be 2.5 cm (1 inch) wide and slightly longer than the seam. Stitch from the right side, using the multi-stitch, zigzag. Widest stitch width 1.5 – 1 mm (20) stitch length. Backstitch at each end. The abutted line should be aligned with the center of the presser foot. Straight stitching may also be used on each side of the abutment. (j) *Top-Stitched Seam*: Top stitching is used as a styling point along the finished edge of a garment or along the seam within a garment. When preparing a curved. Topstitched seam, stay-stitch near the seam line on both the overlap and the underlap. Fold under the seam allowance on the overlap and pin, tack, trim and press. Lap the folded edge a full seam's width over the underlap. Then pin and tack remove the first tacking. Topstitch from the right side, close to the folded edge. If the stitching line with tacking as instructed for Top Stitching.

Plain stitches: Stitches may be divided into plain and ornamental. The plain stitches are the (a) basting, (b) running, (c) the running and back stitch, (d) half back stitch, (e) back stitch, (f) overhand or whipping stitch, (g) overcast, (h) hemming, and (i) blind or slip stitch.

Plain (Tricot) stitch, in warp knitting: see **warp knitting**. Each yarn works in a zigzag fashion lapping between two neighbouring wales. All laps are closed.

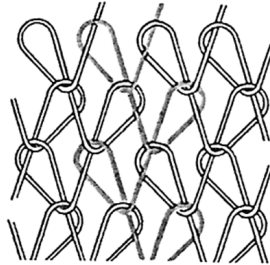

Tricot stitch

Plain straight seam: See **Plain seam**.

Plain surface fabric: A fabric which does not have any intentionally raised fibre or yarn surface such as pile, napped, or tufted surface.

Plain weave: The simplest of all weave interlacings, in which the odd warp threads operate over one and under one weft thread throughout the fabric and the even warp threads reverse this order to under one, over one throughout. A plain weave does not necessarily result in a plain surface effect or plain design in the fabric, e.g. variation in the yarn counts warp to weft or throughout the warp or weft (or both) and variation of the thread spacing warp to weft can produce rib effects (see taffetta, poul, faille and grosgrain), while colour patterning of the warp or weft (or both) results in colour-and-weave effects.

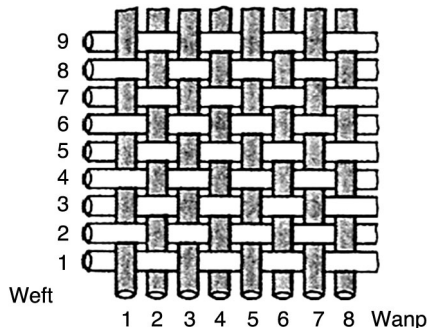

Plain weave cotton fabric: Collective term for plain weave fabrics of different finenesses and thread densities made of single cotton yarn (nettle cloth, coarse cotton cambric), which are sometimes used raw, bleached, dyed or printed. The 3 basic qualities in increasing fineness of the fabric structure are (a) Cretonne; (b) Renforcé; (c) Calico.

Plainback: An English worsted fabric, originated in the 19th century; it is made of single yarn with a twilled face and plain back in imitation of jean.

Plain dyed fabric: A fabric dyed in single coloured, unpatterned.

Plaited goods wagon: Means of internal transport for materials in stacked or rope form.

Plaited stitch: Or herringbone stitch used in embroidery to imitate the herringbone effect.

Plaiter: Device for stacking material in folds.

Plaiting: (1) See **Braiding**. (2) The arrangement of fabric in widthwise folds.

Plaiting down: Stacking of continuous fabric lengths in a zigzag form. Takes up more space than batching.

Plangi: (Malyasian: bright, recessed spot), a resist technique that is still widespread in South East Asia and Africa (like the Japanese Shibori technique) for the patterning of clothing materials. Before dyeing yarn package or binder resistance take place (Ikat), which appears as recessed pattern after dyeing. Stitch plangi is called Tritik. In a wider sense the plangi technique is performed by folding, knotting or weaving, by screens, by resist application (sludge, paste, wax) and by negative resists using dye mordanting. Often several techniques are combined.

Planning: Managing and controlling events to achieve a goal and making the best use of resources.

Planting: A process in weaving by which the various coloured extra warps are interchanged.

Plasma: Plasma is the least organized collection of electrons and atomic nuclei, i.e. it is a mixture of these two components. Material is made of atoms which can be subdivided into electrons and nuclei. In gas phase the matter is in the form of atoms, liquid phase atoms forms unordered bonds and in solid phase they are in ordered bonded state and in most cases symmetrical organization of atoms as in case of crystals. The removal of the atomic bond between electrons and atomic nuclei, typical in plasmas, gives rise to the decisive difference between gases and plasmas.

Plasma Treatments: Plasma treatment is a surface modifying process, where a gas (air, oxygen, nitrogen, argon, carbon dioxide and so on), injected inside

a reactor at a pressure of approximately 0.5 mbar, is ionized by the presence of two electrodes between which is a high-frequency electric field. The need to create the vacuum is justified by the necessity to obtain a so-called cold plasma with a temperature no higher than 80°C. This, with the same energy content that can be reached at atmospheric pressure at a temperature of some thousands of degrees C, permits the treatment of fabrics even with a low melting point such as polypropylene and polyethylene, without causing any form of damage.

Plastic: A high polymer, usually combined with other ingredients such as curatives, plasticizers, and fillers. It can be moulded under heat and pressure and then machined accurately in its hardened state. General term for a wide range of substances.

Plastic-coated textiles: In its widest sense, this group also includes materials of various fibre composition with coatings, rubberizing and coating finishes. More specifically, it is used to describe products in which yarns, knitted goods from cellulose, natural or synthetic fibres are overall coated with synthetic polymers (during manufacture or as a subsequent permanent finish).

Plasticizer: (1) A chemical added to polymers and resins to impart flexibility, workability, or stretchability. (2) A bonding agent that acts by solvent action on fibres.

Plastisol: With reference to textile arts, a type of screen printing ('silkscreen') ink which consists of a coloured pigment, fine particles of polyvinyl chloride, and a plasticizer. Plastisol ink does not dry. It must be heated to the point where the PVC particles melt and mix with the plasticizer and pigment to form a flexible coloured plastic film. Plastisol ink stays on fabric simply because it surrounds and encapsulates the fibres mechanically. This is by far the most popular type of ink for commercial screen printing of t-shirts and the like.

Plastisol coating: (paste coating), working method using Plastisols, consisting of synthetic resin, softener, pigment, stabiliser, etc. in premixed form, which is spread upon the fabric or knitted goods, upon which the resin is hardened.

Plate felting machine: For the manufacture of fabric felts, which are usually used as technical felts. In the plate felting machine the upper plate (50°C) describes a circular or elliptical path, whereas the lower plate (40°C) is fixed. The pressure is mechanically applied.

Plate heat exchanger: Reclamation of heat energy by means of compression moulded plates, which are sealed at the edge. The two media involved in the heat exchange are alternately led through gaps. The heat exchange takes place directly via the exchange surfaces (glass, metal, plastic). There is no exchange of moisture nor dirt transfer from the escaping air flow to the external air flow.

Plated fabric, Knitted: A fabric knitted from two yarns of different properties of which are used in the same loop whilst positioned one behind the other. The special feature of the fabric is that each loop exhibits the characteristics of one yarn on the face side and the characteristics of the other yarn on the reverse side. In the plain weft knitted fabrics when all are formed in the same direction characteristic of one yarn is visible on the surface composed of the face loops while the characteristics of the other are only visible on the reverse surface composed of the back loops.

Plated fabric, cross: An arrangement of a plated face stitch (knitted on one set of needle) and of an adjacent plated reverse stitch (knitted in the same course on the other set of needles) the relative positions of the face yarn and the back yarn in the face stitch being interchanged in the reverse stitch.

Plated fabric, float: The knitting of a plated fabric in which the relationship of the two yarns in is reversed in certain stitches within the same course to give a patterned or fancy effect.

Platille: A fine quality of pure French linen.

Platt: Machine lace made flat without any raised work. The pattern is worked by threads running in zig zag line between straight and parallel threads. Some of these laces have the design outlined by a heavier thread while others are made without this outline.

Pleat: Three layers of fabric involving two folds or reversals of direction; the back fold may be replaced by a seam Pleats are sharp folds of fabric introduced to allow for expansion or to provide style features, which are pressed flat and stitched to place on the top edge. They are heat set into thermoplastic fabric such as polyester and nylon etc.

Pleating: Creation of very varied shapes and arrangements of folds on textiles using Pleating machines. Permanent, wash-resistant pleating can be produced.

Pleating machine: Used for Pleating: (a) Knife, squeezing and group pleating machines for the generation of a wide range of different patterns (approx. 1 mm to several cm underlay area and fold width). (b) Crystal pleating machines for the generation of vertical folds (approx. 1–5 mm fold height). (c) Accordion pleating machines for upstanding folds (5–50 mm fold height). The pleating temperature is always dependent upon the fibre type (thermofixation):

Cellulose 150–200°C

Fibre mixes 150–210°C

Polyamide 6 180–194°C

Polyamide 6.6 190–208°C

Polyacrylonitrile 120–160°C

Polyester 160–180°C.

Pleats: Pleats are sharp folds of fabric. Which are pressed flat and stitched to place on the top edge. They are heat set into thermoplastic fabric such as polyester and nylon etc.

Pleats, Accordion: Narrow straight pleats usually parallel to one another.

Pleats, Box: The fabric is folded equally on both sides and the edges of the pleat meet at the centre of the back of the pleat. It is the combination of two flat folds in opposite direction.

Pleat, Broomstick: Gathers unevenly spread. As the name suggests they are very uneven pleats.

Pleats, Cartridge: These resemble box pleats, but box pleats are very solid pleats whereas these are soft & free flowing pleats. These pleats generally open up or broaden and have a slight flare unlike box pleats.

Pleats, Crystal: Very fine pleats like accordion pleats but much smaller.

Pleat, Inverted: A single reversed box pleat where the pleat is not seen from the front, just the two edges meeting together. These have narrow falls towards one side.

Pleat, Kick: A small pleat placed in a garment to allow more movement, usually in a tight skirt.

Pleats, Knife: Pleats of any width, similar to accordion pleats, but all face the same direction when folded.

Pleat, Re-inforced Inverted: As the inverted pleat, but with the addition of re-enforcements to keep the pleat in a certain position.

Pleats, Sunray: Pleats radiating from a single point usually the centre of full circular skirts.

Pleats, Top – stitched: Any kind of pleat, but part of the pleat is topstitched to create a fixed shape that then contrasts with the unstitched pleat.

Pleats, Watteau: Pleats at the back of a gown, known as the Robe à la Française. The pleats are known as Watteau pleats and are stitched down at the back of the neckline and then allowed to fall freely to the ground.

Pleats, Unpressed: Any kind of pleat that has not been pressed. They have a rounded appearance.

Pleures: French term for pulled wool, taken from sheep that died of natural causes.

Plie: Piece material laid in uniform widths; hanging in plie (e.g. when suspending silk goods), i.e. hung folded on the stick. The stick has three notches for suspension loops, onto which the piece ends can be attached.

Plied yarn: A yarn formed by twisting together two or more singles yarns in one operation.

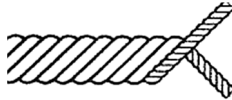

Plied yarn Duck: Duck with plied yarns in both warp and filling (army, numbered and special used ducks).

Plissé: A fabric consisting of alternating wrinkled and plain stripes, often in different colours. The fibre content is usually polyester with cotton. Sometimes crinkled crepe effect can be obtained by special chemical treatments, on ordinary light weight cotton cloth. Caustic soda solution treatment is one type. Caustic soda solution is printed in narrow stripes, whereby those portions are shrunk compared to the unprinted portions. This untreated stripes will pucker causing the crinkling crepe effect. When the stripes in the crinkled crepe are rather wide, the cloth is called plisse. This is a semi-permanent finish which is liable to lessen with constant washing and particularly with ironing. It is a soft cool summer fabric and is used for casual blouses and skirts, beachwear and children's clothing.

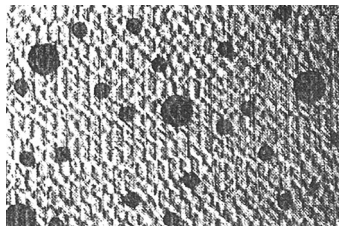

Plisse'; Tisse': Made with very strongly twisted threads which are shrunk in the pretreatment to produce a pleat or relief like fabric appearance.

Plodan: In the 16th century a coarse woollen made in two or three coloured checks worn in Scotland by citizens' wives for cloaks. Believed to be the early form of plaid.

Plommett: A 16th-century fabric in England, made of worsted and silk or linen, the piece weighing 4 lbs. and measuring 14 yards.

Plucked Wool: Shorn from a carcass several days old.

Plucker: (opener, willow). Preparation machines in spinning. Classified as tearing, beating, striking, oil lubrication, mixing, carding plucker, etc. according to application.

Pluckings: Short clean fibre produced at the end of a scotching machine where operatives dress and square pieces of flax ready for selection.

Pluie: Lustrous dress goods and tapestry, made in France of silk or camel hair warp with gold or silver threads interwoven in the filling.

Plugging value: In the manufacture of acetate fibres, a measure of filterability. It is the weight of solids in an acetate dope that can be passed through a fixed area of filter before the filter becomes plugged. It is expressed as weight of solids per square unit of filter area, e.g., g/cm².

Plumage: The out growth of fowl, consisting of feathers and down (waterfowl) or feathers only (non-waterfowl).

Plumetis: Embroidery in feather stitch over a clear and light ground.

Plumules: Downy waterfowl plumage with under developed soft and flaccid quill with barbs indistinguishable from those of down.

Plush: (1) Any cut pile fabric that has a pile length of more than 3 mm, a velvet. The yarns can be almost any natural or synthetic usually acrylic, and many of the fabrics are now washable. Made in various weights for dresses, curtains drapes and upholstery.

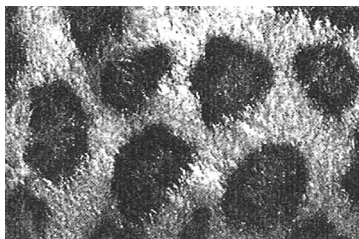

(2) Knitted plush: Plush-like appearance due to pile formation in tricot by a plush loop. Plush cloth. See **Single plush; Double plush**.

Plush Stitch: A stitch applied in Berlin work to form a fringe along the edge of the embroidery and it is left either in loop form or is cut.

Plush carpet: General term for carpets with cut open pile warp (thread pile); either shorter velour-like (velours carpet, Tournay carpet) or longer pile (plush carpet). Named according to material and pattern: Hair yarn, linen, wool, knotted, striped plush carpet, etc. Manufactured in the form of Wire carpets or as Face-to-face carpets (face-to-face tournay carpet).

Plush cloth: (plush fabric, knitted plush), 2–3 thread Knitted fabrics usually made of ground thread and plush thread. The latter are formed into long loops and either closed, curled, frizzy (thermal underwear, jogging suits,

lining material, etc.) or cut, shorn for velvet, pelt or fur like pile goods (lining material, outer material, fake fur, blankets). Pile-knitted fabrics.

Plush trimming: Trimming the pile loops of knitted plush fabrics by Shearing.

Ply: (1) The number of single yarn twisted together to form a plied yarn; also the number of plied yarn twisted together to form a cord.

(2) Individual yarn in a plied yarn or in a cord.

(3) One of the several layers of fabric.

Ply adhesion: See **Ply security**.

Ply broad cloth: See **Broad cloth**.

Ply poplin: See **Poplin**.

Ply Security, in sewing thread: Refers to a sewing thread's ability to stay together during the sewing process. The most common type of thread break is caused by a loss of ply security. When the plies open up during the sewing process they are much more susceptible to breaking and causing an unravelled type of thread break.

Ply voile: See **Voile**.

Ply yarn: Thread made of two or more Yarns twisted together. We talk of 2-ply, 3-ply, 4-ply yarn, etc. Soft ply-yarn made of numerous slightly twisted yarns is also called a wick.

Plying: Twisting together two or more singles yarns or ply yarns to form, respectively, ply yarn or cord.

PN: Polska Norma, Polish standard.

Pneumatic guiders: Expander and edge uncurling device. Works with 2 pneumatic blowers and photoelectric sensors; material is scanned and expanded using compressed air. Differs from mechanical guiders due to non-contact, low tension material guidance.

Pneumatic squeeze: In this screen printing squeegee the squeegee rubber is held pneumatically and can be changed quickly and easily.

Pochote: Very fine and lustrous fibre yielded by the *Eriodendron anfractuosum* in Mexico. It is similar to the kapok. The fibre is used for fine cloth and for hats, in this case mixed with rabbit's fur.

Pocket: A bag for practical or decorative use formed by the inserting or attachment of material to a garment. Pockets may have flaps, jettings or welts. E.g. include- cross pockets, have pocket, jetted pocket, and patch pocket

Pocket, patch: A pocket attached to the outside of the garment and constructed of self-fabric.

Pocket, quarter: The angle from the side seam.

Pocket, rule: A patch pocket attached on the outseam, halfway between the hip and the knee of the garment; usually found on coveralls.

Pocket, serged: A pocket formed by joining two pieces of fabric and joining the edges with safety-stitching.

Pocket, slash: A pocket that must be entered through a slash on the garment. The pocket pouch is suspended from and attached to the slash.

Pocket, stitch and turn: Formed when two pieces of fabric are joined along the edges and turned so that the raw seam margin is inside of the finished pocket.

Pocket, stitched/topstitched: The same as stitch and turn pocket, except with an added row of stitching along the folded edges.

Pocket, swing: The pocket pouch is suspended from and attached.

Pocket, in Zipper: The cavity of an element designed to receive the head.

Pocket, in Zippers: The cavity of a scoop designed to receive the head.

Pocket Drill: Stout, unbleached cotton drill, used for pockets.

Pocket Facing: A piece of shell (outer) material super-imposed on the top of the pocket material at its opening to conceal the lining.

Pocketing: Cotton velvet used for overcoat pockets; also napped cottons used for the same purpose.

pOH: A measure of the concentration of hydroxide ions (OH⁻) in solution - $pOH = -\log[OH^-] = (14 - pH)$; see **pH**.

Poil-grege: (high twist grey pile yarn). Highly twisted Grège threads with approx. 1000–2000 twists/m.

Poile de Chevre: Fine, soft French dress goods made with coloured silk or cotton warp and angora filling.

Point: (1) In hand-made laces denoting fine quality, irrespective of the make; (2) French term for stitch in laces.

Point a l' Aiguille: Lace sprigs made with the needle, irrespective of the design.

Point Anglaise: French for feather stitch.

Point bonding: A method of making thermally bonded nonwoven fabrics in which heat and pressure are applied to specific areas by the use of embossed calendar rollers to cause local bonding.

Point D'Alencon: Same as **Alencon lace**.

Point D'Angleterre: Originated in England as bobbin lace, improved upon by Flemish needle point stitches in the 17th century. The ground shows great variety, the net ground being bobbin-made around the patterns. Often cordonnet or ribs are produced by plaiting the threads and also bobbin made brides or fancy needle jours are employed.

Point d'Esprit: The name describes net fabrics that has embroidered spots or squares on the surface, but the term is often used in relation to any light weight fabric such as voile that is decorated with satin-stitched spots. Unusually polyesters, cotton and sometimes silk First made in France in 1834. Dull surfaced net with various sized holes. Has white or coloured dots individually spaced or in groups. Used for dresses, wedding gowns, curtains, bassinettes, evening gowns, etc.

Point d'Anvers: Same as Antwerp lace.

Point Applique: Applique lace, made of needle-point sprigs attached to a net ground.

Point d'Arabe: Coarse French bobbin curtain lace of Arabian origin, made of ecru cord with large patterns.

Point d'Armes: An embroidery stitch used on transparent materials for leaves and flowers, showing on the face a hemstitch while the threads are crossed in the back in a close lattice fashion.

Point d'IAttache: A variety of stitches in embroidery, by which fancy material is attached to the foundation.

Point de Biais: Embroidery stitch consisting of slanting satin stitches made of different length.

Point de Brabancon: A flat filling used in needle-point laces, consisting of rows of buttonhole stitches linked together.

Point a Brides: Generic term for laces with bars in the ground.

Point Brode: Bobbin lace sprigs, made with raised work.

Point de Bruges: See Bruges lace.

Point de Bruxelles: .See: **Brussels lace**.

Point de Cable: Same as rope stitch.

Point Cam pan: Narrow French bobbin lace edging of the 17th century.

Point a Carreaux: A French bobbin lace made with a simple, trellis-like pattern.

Point de Chainette: Same as **Chain stitch**.

Point de Champ All laces having a mesh ground, irrespective of style.

Point de Chant: See **Point de Paris**.

Point Chaudieu: In macrame lace a chain bar, formed by looping one thread around the other.

Point Chemin de Fer: Same as **Railway stitch in embroidery**.

Point de Cone: In guipure lace a cone shaped form stretching over four square meshes and filled in with cloth stitch.

Point de Cordova: A filling in needle-point laces, made stretching three threads close to each other and darning dote over.

Point de Cote: Same as **Rope stitch**.

Point Coute: See **Darned lace**.

Point Crochet: A lace made by crocheting; the various sprigs are made separate and joined together with bars, resulting in a guipure lace.

Point Croise: An embroidery stitch which forms in the front rows of continuous short stitches (like the hemstitch) while the thread is crossed in the back.

Point de Croix: Same as **Cross stitch**.

Point de Diable: An embroidery stitch, consisting of a star with eight rays in a square.

Point de Dieppe: Same as **Dieppe point**.

Point Double: See **Point de Paris**.

Point Duchesse: See **Bruges lace**.

Point d'Epine: Same as **Feather stitch**.

Point d'Escalier: Same as **Ladder stitch**.

Point d'Espagne: Heavy guipure-like needle-point lace of the 17th and 18th centuries somewhat resembling **Point de Venise** and made of gold or silver thread with thick cordonnet outlines.

Point d'Echelle: A variety of ladder stitch in embroideries in which the bars are stitched across an open space.

Point d'Esprit: (1) Machine net with small dots scattered all over. (2) Light and open stitches in needle guipure laces, consisting of loops forming various patterns in the square meshes.

Point d'Etoile: A stitch over square mesh ground in needle-point laces; it is a more or less ornate star, covering nine or 16 squares.

Point Evantail: In guipure laces fan shaped spots formed by darning stitches.

Point Faisceau: A heavy stitch in needlepoint laces, consisting of herringbone stitches joined with a loop in the centre.

Point de Feston: A filling in needle-point laces, consisting of festoons fastened with a knot at every loop.

Point de Feuillage: In raised macramé lace a bar made with four threads.

Point de Filet: A ground in needle-point laces made by fastening loc-ps to each other in buttonhole stitch, which form a filet mesh.

Point de Flanders: See **Brussels**.

Point de France: Term applied to French needle-point laces similar to the Point de Venise started by Colbert in the 17th century.

Point de Gauze: Very fine needle-point mesh for Brussels lace.

Point de Genes: (1) A species of Aetzstickerei (see), made on a wool ground; (2) A stitch over square mesh in needlepoint lace; two or three threads are stretched diagonally across several squares of the mesh and fastened together by darning.

Point de Gerbe: A stitch in guipure lace, made by looping a thread several times around the opposite sides of a square mesh, forming buttonhole loops on one side; the threads are drawn together at the middle in a buttonhole stitch.

Point de Gibeciere: A bar in macramé lace formed by four threads, divided into two even groups and looped over each alternately.

Point de Gobelin: See **Gobelin stitch**.

Point de Grecque: A ground in needlepoint laces, consisting of darned square spots alternating with octagonal meshes.

Point Guipure: See **Guipure lace**.

Point de Havre: Narrow French needlepoint lace of the 17th and 18th centuries, similar to Valenciennes.

Point d'Hongrie: French rug of hemp warp and silk filling with various figures.

Point d'Irlande: Inferior machine imitation of Venise lace

Point draws: Point draws are a combination of a regular straight draw from back to front and one from front to back, the first and the last shafts only being used once, while the rest receive two ends each in one repeat of the draw.

Point Jesuit: Crochet imitation of Venise laces made in Ireland.

Point de Jours: In embroidery open spaces with buttonholed edge and some filling.

Point Lace: Made by the needle and thread. The term “point” applied also to very fine bobbin laces.

Point Lache: In needle-point laces triangles filling half of the square meshes; they consist of rows of buttonhole stitches linked together.

Point Lance: An embroidery made with short, straight and broken stitches in coloured wool.

Point de Malines: (1) Same as Maline lace. (2) A filling used in needle-point laces, consisting of small circles, buttonholed all around and connected with each other in a zig-zag line.

Point de Marli: A bobbin made net used as ground for bobbin laces in the 18th century.

Point de Medicis: Old name for Italian needle-point lace with raised cordonnet.

Point Mexique: In Mexican embroidery the outlining buttonhole stitch in black or coloured silk.

Point de Milan: Lace with a small mesh ground and large trailing scroll pattern.

Point a la Minute: Cross and star shaped titches; used to fill in small spaces.

Point de Moscow: Early Italian needlepoint laces in Russian designs. See also *Russian lace*.

Point Natte: (1) Embroidery made with pieces of bright satin applied on a dark foundation, the edges fastened with braid; the pieces of satin are embroidered in floss silk or wool yarn. (2) An embroidery stitch arranged in herringbone effect without a center line.

Point Neige: (1) Needle-point lace of very fine design ornamented with various loops and picots. (2) A crochet work, made with regular open places and stitches radiating from each opening; used for quilts and jackets.

Point Net: Net made by the needle and used as ground for applique laces before the invention of the bobbinet.

Point None: Same as **Buttonhole stitch**.

Point Noue: In needle-point laces a knotted buttonhole stitch.

Point Ondule: Double bar in macramé lace.

Point d’Or: See **Point de Pois**.

Point de Paris: Narrow French bobbin lace of the 17th century, similar to Brussels.

Point de Paris: Ground For black bobbin laces, consisting of hexagons and triangles.

Point paper design, in weaving: See **Pattern Draft**.

Point Passe: Same as **Satin stitch in embroidery**.

Point Pecheur: Italian bobbin lace, made in white or black, similar to the Maltese lace.

Point Perle: Same as **Satin stitch**.

Point Plat: In laces such patterns which have no raised parts.

Point Plat: Applique 'Modern Belgium lace of bobbin made sprigs applied to machine-made net.

Point de Plume: A padded satin stitch.

Point Plumetis: Same as **Feather stitch**.

Point de Pois: An embroidery stitch, consisting of small dots.

Point de Poste: See **Point de Pois**.

Point de Pyramide: Same as **Point da Cone**.

Point de Raccroc: Same as **Raccroc stitch**.

Point de Ragusa: Same as **Ragusa lace**.

Point de Repasse: See **Cloth stitch**.

Point de Reprise: A filling in needle-point laces, consisting of darned triangular spots.

Point a Reseau: Needle-point lace, the pattern being formed by the meshes of the ground.

Point de Riz: In embroidery short, irregularly scattered stitches with a fancied resemblance to rice.

Point de Rose: (1) one of the most delicate needle laces, made originally in Venice, where the art revived of late. The beautiful and intricate patterns are made in raised effect, connected with bars; (2) a stitch in embroidery, consisting of broad buttonhole stitches over a padded surface.

Point Russe: Short straight stitches in fancy embroidery, forming geometrical patterns, Irke stars, diamonds, crosses, etc.

Point de Sable: See **Point d'Armes**.

Point Saracene: French tapestry made in imitation of Turkish carpets.

Point Serre: A stitch in needle-point laces; the thread is carried diagonally across each square mesh, looped and drawn tight and carried across the following meshes in zigzag line.

Point de Sorrento: Ground in needle-point laces; it consists of a series of long loose loops, each worked around by a number of loose buttonhole stitches.

Point Tiellage: A stitch in needle-point laces; the thread is carried diagonally across a square mesh and twisted half way around the knot in the corner and carried afterwards through the next mesh. A second thread is carried between the same corners of the squares, but as it is twisted the opposite way around the corners, it forms a slight angle with the first thread.

Point de Tigre: Same as **Overcast stitch**.

Point Tire: See **Drawnwork**.

Point de Toile: See **Cloth stitch**.

Point Tresse: 16th-century pillow lace of human hair.

Point de Tricot: In crocheting forming large open squares by chain stitches; used for fancy quilts, made of heavy wool yarn.

Point de Tulle: (1) See **Mignonette**. (2) A very fine ground in needle-point laces.

Point Turc: (1) A filling in needle-point laces, consists of rows of interlinked festoons fastened to straight threads. (2) Same as ladder stitch in embroidery.

Point de Valenciennes: (1) Same as Valenciennes lace. (2) A filling in needlepoint laces, consisting of squares separated by open work; the squares are made of rows of buttonhole stitches linked together.

Point de Venise: (1) the finest of the needle-point laces, the characteristics being the padded cordonnets, the design often being raised repeatedly, the great variety and fineness of the stitches and the rich ornamentation of the edges of the patterns and the brides with picots and stars; (2) A filling in needle-point laces, consisting of rows of festoons, the loops in every alternate row being fastened with four buttonhole stitches.

Point paper: A special paper for designing woven fabrics. The standard point paper used is ruled in groups of 8 x 8, separated by thicker bar lines.

Pointed 2/2 straight herringbone: See **Herringbone**.

Pointille: French for small dots.

Poiret twill: Named after poiret, the French designer. This is a firm, twilled worsted material, but its twill is pronounced, and steeply angled. A typical construction is 3/3, 45 degree twill but may be made in a 63 degree twill weave also. The fabric normally has twice as many ends as it has picks in the construction. Used for women's wear dress goods.

Poise': Out-dated measure for dynamic Viscosity. Replaced in the SI system by Pascal seconds (Pa · s): 1 P = 0.1 Pa·s.

Poke bonnet: Richlydecorated bonnet-hat with a broad brim; tied with ribbons under the chin.

Polacrylate sizes: Polyacrylate based sizing agents. Conventional polyacrylate sizes primarily in the form of sodium or ammonium poly salts:

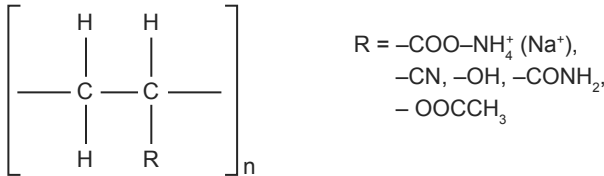

Polyacrylate sizes of very different chemical composition in the form of “universal sizes” are an important class of size products for filament yarns in general. They produce good effects when used in water jet power looms, with a size film that is resistant to the influence of cold, neutral water. After weaving the polyacrylate sizes, present in acidic form, can be made water soluble again at an alkaline pH and washed out. New generation moisture insensitive and thermostable sizes by partial or total substitution of ammonium or sodium in specific copolymers (acrylonitrile/acrylic acid) by earth alkalis (e.g. magnesium, sodium, calcium salts). Such Polyacrylate sizes can be completely washed off even after raw thermofixing because they are soluble in hot and cold water at high concentrations (up to approx. 25%).

Polar: Terminal, working in opposite directions (Dipoles). For example, in textile auxiliary products the polar arrangement of the hydrophilic group in relation to the hydrophobic group. In the wetting process, water molecules are in a polar arrangement to the auxiliary at the boundary layer, if the latter aligns its hydrophilic (negatively charged) groups against the positively charged groups of the surrounding water.

Polar bond: Another name for Ionic bond.

Polar group: Functional group, the electron distribution of which gives the molecule a considerable Dipole moment (Polar). It determines the affinity to markedly polar liquids (particularly to water) and the Hydrophilic molecule character.

Polarin: Curl pile fabrics with a cut mohair pile.

Polemite: Holland and French solid coloured camlet, made of two-ply Angora warp and worsted filling, forming cross ribs.

Polished cotton: A plain-weave cotton fabric, often inexpensive, that has been calendared to give it an attractive shine. The calendaring does not

survive laundering so garments have to be starched, unless a resin finish is added, when the finish is permanent. Many weights of cotton may be polished and used for curtains, loose covers, dresses etc. Handle as for curtains, loose covers, dresses etc.

Polished Twine: Two-ply coarse hemp or flax twine with a smooth finish; used in stores to tie packages with.

Polishing: Usually done on commercial sewing thread, the process involves burnishing the plied yarn.

Polishing: The treatment of tanned skins or of fabrics particularly pile fabrics, to increase the lustre by mechanical means, without compressing the material.

Polka Dot: Round printed dots differing in colour from the ground.

Polka Gauze: Swivel embroidered dots scattered over a gauze ground; used for dresses, etc.

Poll: (1) French term for pile; (2) silk thread used as core for gold tinsel, consisting eight or 10 reeled filaments twisted together.

Poll seaux: Coarse, stout French linen canvas of various widths.

Polledavy: Unbleached French hemp sailcloth.

Pollution: Any damaging or unpleasant change in the environment that results from the physical, chemical, or biological side-effects of human industrial or social activities. Pollution can affect the atmosphere, rivers, lakes, seas, and soil. Air pollution is caused by the domestic and industrial burning of carbonaceous fuels, by industrial processes, and by gases in car exhausts. Among recent problems are industrial emissions of sulphur (IV) oxide, a cause of acid rain, and emissions of chlorofluorocarbons (CFCs), previously widely used in refrigeration, aerosols, etc., and linked to the depletion of ozone in the stratosphere. Carbon dioxide, produced by burning fossil fuels, is slowly building up in the atmosphere, which could result in an overall increase in the temperature of the Earth due to its greenhouse effect. Car exhausts also emit carbon monoxide and, if leaded gasoline (petrol) is used, lead. Atmospheric CO has not yet reached dangerous levels, but vegetation near main roads has in the past been found to contain a high proportion of lead, with levels sufficiently high in urban areas to cause concern about the effects on children. Leaded gasoline has thus been banned in many countries. Photochemical smog, caused by the action of sunlight on volatile hydrocarbons and nitrogen oxides from car exhausts, is a problem in several countries. Catalytic converters have helped reduce harmful emissions from vehicle exhausts.

Water pollutants include those that are biodegradable, such as sewage effluent, which cause no permanent harm if adequately treated and dispersed, as well as those that are non-biodegradable, such as certain chlorinated hydrocarbon pesticides (e.g. DDT) and heavy metals, such as lead, copper, and zinc in some industrial effluents, which cause heavy-metal pollution. When these pollutants accumulate in the environment they can become very concentrated in food chains. The pesticides DDT, aldrin, and dieldrin are now banned in many countries. Water supplies can become polluted by leaching of nitrates, pesticides, or animal wastes from agricultural land. The discharge of waste heat can cause thermal pollution of the environment, which can be reduced by the use of cooling towers. In lakes, rivers, and the sea, spillage from tankers and the discharge of inadequately treated sewage effluent are the main problems. Other forms of pollution are noise from aircraft, traffic, and industry and radioactivity from improper disposal of radioactive waste.

Pollution index: (waste water), characteristic figure relating to waste water, derived from measured COD values ($\text{mg O}_2/\text{l}$), BOD values and water quantity in l/kg material; See Waste water evaluation.

Polo Cloth: The name given to top quality highly napped fabric that is made into sportswear and polo caps and coats, jackets etc. Mainly produced in expensive looking shades of brown, Made from wool, it may be woven or knitted.

Polonaise: Corded silk dress goods, made in France.

Poly-1,4 cyclohexylene dimethylene terephthalate fibre: Poly-1,4- resembles polyethylene terephthalate in most properties: The cyclohexylene group within this fibre provides additional rigidity to the molecular chains, but the packing of adjacent polymer chains may be more difficult due to the complex structure. As a result, the fibre has a lower tenacity than polyethylene terephthalate. It has a tenacity of 2.5-3 g/d (22-27 g/tex) and exhibits lower elongations than polyethylene terephthalate. It has a lower specific gravity (1.22-1.23) than polyethylene terephthalate. The fibre melts at $290^\circ\text{-}295^\circ\text{C}$ and is attacked and shrunk by trichloroethylene and methylene chloride. The fibre has good chemical resistance. The major trade name for this polyester is Kodel II. The fibre is somewhat superior to polyethylene terephthalate in certain end-use properties including better recovery from stretch and better resistance to pilling. The fibre has superior resiliency and is particularly suited for use in blend with cellulose and wool, as a carpet fibre, and as fiber fill.

Poly-m-phenylenedibenzimidazole fibre (PBI): PBI was developed by the U.S. Air Force and Celanese as a flame retardant fibre for use in aerospace applications. The fibre is spun from N,N-dimethylacetamide followed by derivatization with sulphuric acid to form a golden fibre. It has moderate strength (3 g/d or 27 g/tex) and good elongation at break (30%), a moderate density (1.4 g/cm³), and a high moisture regain (15%). Fabrics from the fibre possess good hand and drape and are stable to attack by ultraviolet light. PBI does suffer from poor dye ability, however. In addition to its low flammability, the fibre has a high degree of chemical and oxidation resistance, does not show appreciable heat shrinkage up to 600°C and generates only small quantities of smoke and toxic gases on ignition. In recent years, it has shown potential as a replacement for asbestos, as a flue gas filter material, and as an apparel fabric in specialized applications.

Poly-p-ethyleneoxybenzoate fibre: This fibre was introduced by a Japanese firm as A-Tell. The properties of the fibre are very similar to the polyesters containing terephthalate units in most respects including tensile properties, specific gravity, melting point, chemical resistance, and sunlight resistance. As a result, the FTC expanded the polyester category to include the polymeric p-ethyleneoxybenzoate esters. The fibre is produced by reaction of ethylene oxide with p-hydroxybenzoic acid, followed by melt spinning. The fibre has a tenacity of 4-5.5 g/d (36-50 g/tex) and an elongation at break of 15%-30% with nearly complete recovery from low elongation. Its specific gravity of 1.34 and moisture regain of 0.4%-5.0% are nearly the same as that of polyethylene terephthalate polyester. The fibre melts at 224°C and softens at about 200°C. The fibre is reported to be even more resistant to attack by acids and bases than terephthalate-based polyesters. The properties of this fibre were not sufficiently different from other polyesters to achieve reasonable market penetration, and the fibre has been discontinued.

Poly tetrafluoroethylene fibres: Fibre made of polytetrafluoroethylene chains. These fibres of high physical and chemical stability are made by melt spin process and cold drawn into extremely fine threads. They are beige-brown in colour, soft slippery, cross-section round. Properties: density 2.3; normal moisture absorbency 0.02% (unwetable); virtually non-flammable (glows in flame); softening point approx. 327°C; at 225°C, 15% fall in tear resistance; at 310°C full strength loss; m.p.400°C with decomposition. ; strength dry/wet 16-27 cN/tex; elongation dry/wet 13-15%; dermatologically harmless; resistant to mildew, bacteria, insects, weather resistant; almost totally resistant to acids, alkalis, organic solvents; difficult to dye (disperse dyes; spin dyeing). Application: for technical purposes (filter cloth, packing material, protective clothing, dye bags, screen printing gauze, etc.), also for non-wovens

Polyacrylates: Polyacrylates: I. Polyacrylic acid salts; Polyacrylic acid ester of following formula.II.

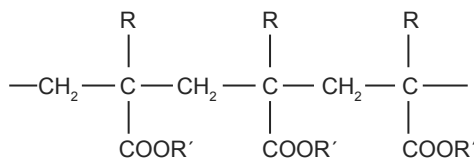

Polyacrylate

Polyacrylate products are for example used as finishing agents, coatings, binders for pigment printing, fibres, laminating agents, adhesives, sizes, thickeners, materials.

Polyacrylic acid. Polyacrylic acid is a water soluble polyelectrolyte that has excellent adhesion to nylon therefore it is used to size filament nylon yarns.



The affinity is through hydrogen bonding of the $-\text{COOH}$ with amide and amine end groups in the nylon polymer. Application for sizes, finishes, adhesives, binders, etc. Polyacrylic acid ester and Polyacrylic acid salts are of greater importance.

Polyacrylic acid salts: Sodium and Ammonium salts of Polyacrylic acid.



Water soluble, produce solid, elastic films with antistatic properties. Application: Sizing agents, finishing agents, thickeners for synthetic dispersions in coating finishes, coatings.

Polyacrylonitrile: (polyacrylic acid nitrile, polyvinyl cyanide), polymer of Acrylonitrile.



Used in emulsions or dispersions (particularly copolymers with butadiene, styrene, vinyl ether) primarily for wash fast finishes, for coating and laminating,

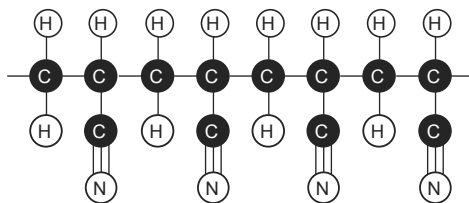

Repeat unit of polyacrylonitrile

as a material and for synthetic fibres (Polyacrylonitrile fibres; Modacrylic fibres). Acrylonitrile polymer emulsions with ammonium chloride as a catalyst can develop, when hardening, a toxic bi-chloromethylether (lung cancer hazard).

Polyacrylonitrile fibres: Group of synthetic polymeride fibres, the chain of which is made up of at least 85% Acrylonitrile. Polyacrylonitrile fibres are produced by dry or wet spinning and drawing (8–12 fold). Further processing from single titre 0.6 dtex upwards. The cross-section varies, usually dumbbell-like (dry spinning process) or kidney-shaped (wet spinning process).

Poly-addition: This operation joins together several molecules and redistributes the valence links existing in the monomers, however without removing secondary products.

Many unsaturated compounds which are characterized by the presence of a double link between two adjacent carbon atoms as ethylene and its derivatives, polymerise according to this reaction; within this category fall e.g. acrylic and polyolefin fibres. Among the most used polymers there are ethylene derived molecules with one or more substitutes of hydrogen atoms.

For example: $\text{CH}_2 = \text{CHX}$

Where X = H, CH_3 , Cl, CN, OH and other groups.

The chains which are thus formed originate from simple openings of double ethylene links and are therefore characterized by links only among carbon atoms.

Polyalcohols: Alcohols with several OH groups, which includes glycols, glycerol $\text{C}_3\text{H}_5(\text{OH})_3$ and sugar alcohol, but specifically high molecular alcohols such as polyglycol, polyglycerol, polyvinyl alcohol, cellulose (approx. 10 000 -OH groups).

Polyamide: A synthetic polymer family used for fibres and solid plastics; protein fibres are also technically polyamides, but the term is almost always used only for synthetic materials Nylon is a polyamide, and the oldest of the commercial synthetic polymers. Polyamide can be dyed with acid dyes or disperse dyes. Some MX dyes will also work well for nylon if applied as if they were acid dyes (at acid pH and high temperature). Fully imidized, manufactured fibre formed from the condensation polymer of an aromatic dianhydride and an aromatic diisocyanate. The fibre is produced by dry spinning. It is a high-shrinkage fibre used in the formation of mechanically stable nonwoven fabrics. These fabrics are made without binders or resins; bonding apparently results from the local temperature and pressure that develop during shrinkage.

Polyamide dyes: Practical term for dyes for dyeing polyamide fibres. Selected dyes, specifically for dyeing polyamide, are disperse, acid and metal-complex dyes, which are usually classified into specific ranges. Developing, chrome and reactive dyes are also suitable. Pigment dyes can also be used for light shades.

Polyamide fibre: See **Polyamide**.

Polyaramide fibres: See **Aramid fibres**.

Polyarylate: High-temperature-resistant aromatic polyesters from bisphenols.

Polybenzimidazole fibre (PBI): A manufactured fibre in which the fibre-forming substance is a long chain aromatic polymer having recurrent imidazole groups as an integral part of the polymer chain. (FTC definition). The polymer is made from tetraaminobiphenyl and diphenyl isophthalate and is dry spun from a dope with dimethylacetamide as a solvent. Characteristics: A high-performance fibre with high chemical resistance that does not burn in air. It has no melting point and does not drip when exposed to flame. The fibre and fabrics from PBI retain their flexibility, dimensional stability, and significant strength without embrittlement even when exposed to flame or extreme heat. The fibre emits little smoke in extreme conditions. It processes well on conventional textile equipment, having processing characteristics similar to polyester. It can be used in 100% form or blended with other fibres. It has a high moisture regain and low modulus with comfort properties similar to cotton. The natural colour of PBI is a gold-khaki shade, but it can be dyed to almost any medium to dark shade with conventional basic dyes. End uses: With excellent thermal, flame, and chemical resistance, combined with good comfort properties, PBI is a good fibre for many critical uses including: firefighter's protective apparel, aluminized proximity gear, industrial apparel such as pants, shirts and underwear, protective gloves, welder's apparel, aircraft fire-blocking layers, aircraft wall fabrics, rocket motor insulation, race car driver's apparel, and braided packings among others.

Polyblends: See **Biconstituent fibres**.

Polybuteneterephthalate (PBTP): Polytetramethylene terephthalate fibre.

Polycaproamide fibres: Rare term for Polyamide fibres of type polyamide 6 or polyamide 6.6.

Polycaproamides: Group of polyamide fibres of type polyamide 6 (base Caprolactam).

Polycarbonate Fibres: Polycarbonate fibres are linear polyesters of aliphatic or aromatic dihydroxy compounds with carbonic acid and has excellent resistance to heat and weathering.

Polycondensation products: (polycondensate, polycondensation resin, polycondensation plastic), products of Condensation polymerisation, in the form of plastics or synthetic resins, such as : Alkyd resins; Epoxy resins; Urea-formaldehyde compounds; Ketone resins; Melamine-formaldehyde compound; Phenolic plastics; Polyamides; Polycarbonates, Polycondensation fibres; Polysulphides.

Polychlal fibre: A manufactured, bicomponent fibre of polyvinyl alcohol and polyvinyl chloride. Some vinyl chloride is grafted to the polyvinyl alcohol (Japanese Chemical Fibres Association definition). The fibre is emulsion spun into tow and staple. Characteristics: Polychlal fibres have a soft, lamb's wool-like hand and moderate moisture regain. The fibres are also characterized by high flame resistance and high abrasion resistance. End uses:: Polychlal fibres are suitable for end uses such as children's sleepwear, blankets, carpets, curtains, bedding, upholstery, nonwovens, and papermaking.

Polychromatic: Multi-coloured, bright. Opposite of Monochromatic.

Polychromatic dyeing: For fabrics and carpets. In principle this consists of aiming separate jets and dye solutions at continuously running lengths of material, before and whilst the material passes through squeeze rollers. The application device consists of a number of colour jets and is attached to two or more rods. The length of the rods is the same as the width of the application machine. The nozzles direct the jets of dye liquor at an inclined plate and from there onto the length of material (Dye Weave) or directly onto one of the two squeezing rollers (Flow Form). The nozzle rods can be moved backwards and forwards and in this manner form patterns and colour mixtures (Space dyeing).

Polychromatic printing: Multi-coloured printing with a printing roller.

Polychrome: Bobbin lace made of fine silk threads of various colours.

Polycondensation: See **Condensation polymerisation, Polycondensation fibres. Polycondensation products.** By polycondensation, two molecules of same type or of different types are joined together to form macromolecules by removing simple secondary products as water, hydrochloric acid, alcohol. The prerequisite for reactions of this type is the presence in the molecule (monomer) of two terminal reactive groups with functional properties. The molecules composed of 2,3,4...n monomers are named dimers, trimers, tetramers (oligomers)...polymers. Some of the mostly used monomers are: (1) Aliphatic di-acids HOOC-R-COOH (used for nylon 6.6). (2) Aliphatic di-amines $\text{NH}_2\text{-R-NH}_2$ (used for nylon 6.6) Aliphatic amino acids $\text{H}_2\text{N-R-COOH}$ (used for nylon 6). (3) Aromatic di-acids HOOC-Ar-COOH (used for

polyester). (4) Diols (bi-functional alcohols) HO-R-OH (used for polyester) etc.

Polycondensation, Melt: The production of polyethylene terephthalate from dimethyl terephthalate and ethylene glycol, and nylon 66 are prepared by using melt polycondensation technique. In this method, one of the monomers used is solid, which cannot decompose around its melting point. The reaction has to be carried out in an inert atmosphere of N_2 or CO_2 to avoid side reactions such as oxidation, decarboxylation, etc.

Polycondensation, Solution: In the solution polycondensation technique, all the reactants are dissolved in an inert solvent as a solution, therefore, the whole system is in a homogeneous phase. In this method, the reaction can be carried out at low temperature during which mass and heat transfer processes are comparatively easier. The solvent can also help as an entrapping agent for the by product formed; hence the removal of the by product from the final product and solution becomes easy. This technique is useful in the preparation of liquid polyester resin from the glycols and unsaturated dicarboxylic acid using high boiling aromatic hydrocarbon as solvent.

Polycondensation fibres: Currently the most important main group of Synthetic fibres (natural fibres also belong to the group of polycondensation fibres), which are created by Condensation polymerisation, i.e. by a condensation reaction between the different molecules (intermolecular condensation), whereby smaller molecules, such as water or alcohol, form due to splitting or as a secondary product. Unlike Polymerization fibres, the main chain contains carbon and foreign atoms (usually nitrogen, sulphur, oxygen) or linking polar groups ($-COONH-$, $COO-$, etc.).

Polycondensation products: (polycondensate, polycondensation resin, polycondensation plastic), products of Condensation polymerisation, in the form of plastics or synthetic resins, such as : Alkyd resins; Epoxy resins; Urea-formaldehyde compounds; Ketone resins; Melamine-formaldehyde compound; Phenolic plastics; Polyamides; Polycarbonates, Polycondensation fibres; Polysulphides.

Polycotton: A short form for polyester/cotton blended fabric.

Polyelectrolyte: A *polymer* that carries ionisable groups. When dissolved in water, they acquire many positive or negative charges (cationic or anionic polyelectrolytes). As a *coagulant aid*, a polyelectrolyte is added to water in small quantities to help in the *flocculation* of fine suspended solids or colour molecules by reducing their surface charges and also by enmeshing fine solids or colour molecules in the long chain molecules of the polyelectrolyte. They are used in the *conditioning* of sludges from water or wastewater treatment.

Most of them are *polyacrylamides* or compounds of polyacrylic acid. A few are polyamides or quaternary ammonium compounds. Non-ionic polyelectrolytes are a misnomer. They are either *ampholytic* or do not ionise at all, and should not be called polyelectrolytes.

Polyene and polymethine dyes: Polyene and polymethine dyes are two structurally related groups of dyes which contain as their essential structural feature one or more methene (CH=) groups. Polyene dyes contain a series of conjugated double bonds, usually terminating in aliphatic or alicyclic groups. They owe their colour therefore simply to the presence of the conjugated system. In polymethine dyes, electron-donor and electron-acceptor groups terminate either end of the polymethine chain, so that they may be considered as typical donor—acceptor dyes.

Polyester: A man-made fibre of great strength. It is treated in various ways and mixes well with other fibres like cotton. A manufactured fibre in which the fibre-forming substance is any long chain synthetic polymer composed of at least 85% by weight of an ester of dihydric alcohol and terephthalic acid (FTC definition). The polymer is produced by the reaction of ethylene glycol and terephthalic acid or its derivatives. Fibre forms produced are filament, staple, and tow. The process of production resembles that of nylon. Polymerization is accomplished at a high temperature, using a vacuum by one of two methods. (1) The glycol and a terephthalate ester react to form a polymer chain, releasing methanol; or (2) the glycol and terephthalic acid react directly to form the polymer

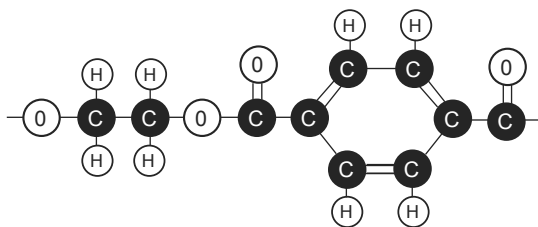

Repeat unit of the Polyester macromolecule

with water as the by-product. As with nylon, the filaments are spun in a melt-spinning process, then stretched several times their original length, which orients the long chain molecules and gives the fibre strength. A somewhat generic term used for a variety of synthetic polymers used both for solid plastics and for fibres; polyethylene terephthalate is probably the most common Polyester is are harder to dye than many other fibre polymers. It is dyed almost exclusively with disperse dyes. Because of its high glass transition temperature, dyeing is usually done at high temperature (around 130°C) in

apressure vessel. Carriers can be used for dyeing at the boil. Washfastness of polyester is very high because it is almost impenetrable to water even at the boil. Some polyester is formulated to allow dyeing with basic dyes. Polyester containers (often labelled PET or PETE), very popular for beverages, can be used for dye solutions, at least for short term storage. Polyester is attacked by strong alkalis. A few stitches of brightly-coloured polyester thread can be handy for 'labelling' items being dyed in almost any process other than disperse dyeing, because they will retain their original colour.

Characteristics: Polyester fibres have high strength and are resistant to shrinking and stretching. Fabrics are quick drying and tend to have wrinkle resistance and crease retention, wet and dry. Polyester is used alone and in blends. It has been one of the first fibres to be developed in fabrics with durable-press features. **END USES:** Polyester is widely used in many types of apparel fabrics such as textured knits and wovens, durable-press blend fabrics, shirtings, dress goods, rainwear, worsted-blend summer suitings, sleepwear, underwear, bloused, and lingerie. It is also used extensively in floor coverings and for tire cord and other industrial uses such as sewing thread. Polyester fiberfill is used in filled items such as quilted jackets, comforters, pillows, furniture cushions, and sleeping bags.

Polyester chiffon: See **Chiffon**.

Polyester cotton: Polyester and cotton are mixed in various percentages according to the weight and type of fabric produced. The advantage over 100 % cotton is that the polyester reduces creasing and provides good draping qualities. It also makes the fabric more hard wearing. It may be plain, or printed or woven in patterns. Used for blouses, shirts, nightwear, children's clothes etc.

Polyester crepe': A soft synthetic crepe in a wide range of plain colours, which has largely replaced other types of blouses, dresses, evening wear, lounging pyjamas, negligees. It is hard wearing.

Polyester dyes: Simplified practical term for dyes for Dyeing of polyester fibres.

Polyester elastomers: (polyester rubber), Elastomers based upon polyester, which require no cross-linking. Some properties: unusual resistance against impact/bending cracks, good fabric adhesion; resistance against diluted acids good, against concentrated acids poor; against solvents excellent/good; against oxidation (ozone) excellent; against sunlight good; against ignition moderate to good.

Polyester fibre: The generic name for fibres made from a synthetic linear polymer that contains, in the chain, at least 85% (m/m) of an ester

of a substituted aromatic carboxylic acid, including but not restricted to terephthalate units $p(-R-O-CO-C_6H_4-CO-O-)$ and para substituted hydroxyl benzoate units $p(-R-O-C_6H_4-CO-O-)$.

Polyester fibres in printing: Disperse dyes are used for direct printing procedures. They can be classified on the basis of their fixing properties:

fixation type and time,

- hot air 15–30 s,
- saturated steam 45–60 min,
- high pressure saturated steam 20–30 min,
- superheated steam 2–9 min.

When fixing in superheated steam, hot air or contact heat on hot cylinders fixation accelerators, e.g. based upon alkyl phenols, can be useful.

Polyester gauze: The low moisture absorption, which results in good deformation resistance is particularly beneficial for Screen making. Polyester gauze also possesses good light resistance and low elongation with good elasticity. Polyester gauze has to a large degree supplanted Polyamide gauze, although dye paste penetration and abrasion resistance are somewhat lower.

Polyester georgette: See **Georgette**.

Polyester honan: A fine textured fabric with a silky finish and a slub yarn across it. It resembles a heavy georgette but is softer to touch.

Polyester jersey: Close plain knit fabrics often printed, in various weights from very thin to fairly heavy. The light weight fabrics drape well and are soft, slippery and shiny, although those made from spun polyester are a matt. These fabrics often cause static problems which may be lessened by using appropriate finishes. Used for dresses, robes, evening clothes, light suits.

Polyester polyamide biconstituent fibres: It represent a two-phase system, composed of a polyester matrix containing evenly distributed polyamide fibrils. Acid and metal-complex dyes only dye the polyamide component. As the dyeing effect is only superficial it can be influenced by treating the biconstituent fibres in such a way as to bring about an increase in the polyamide content in the surface layers of the fibres and the formation of micropores, thus promoting the diffusion of the dye solution.

Polyester resins: High molecular cross-linking products made of unsaturated Polyester and unsaturated polymerizable compounds (e.g. styrene). Of interest for lacquers, coatings and materials, because many polyester resins are available as more or less viscose fluids (so-called casting resins), which only

harden after the addition of a catalyst (peroxy compounds) and accelerator, e.g. with excellent strength, proven on fibre glass materials as a binder.

Polyester satin: A satin that creases very little, due to its fibre content, and is soft and comfortable to wear and drapes well. It is made in various weights suitable for lingerie, blouses and evening wear. It has less lustre than satins made from shiny fibres like silk, or acetate.

Polyester sheer: Firm vision net used for curtains. Fibres vary but polyester is mainly used, because it does not lose its colour. Fibre combinations include polyester and silk, and polyester, acrylic and nylon.

Polyester voile: Very fine polyester curtain net made in various widths. It is soft, crapes well and keeps its colour.

Polyester-polyamide biconstituent fibres: It represents a two-phase system, composed of a polyester matrix containing evenly distributed polyamide fibrils. Acid and metal-complex dyes only dye the polyamide component. As the dyeing effect is only superficial it can be influenced by treating the biconstituent fibres in such a way as to bring about an increase in the polyamide content in the surface layers of the fibres and the formation of micropores, thus promoting the diffusion of the dye solution.

Polyetheretherketone fibre (PEEK): A manufactured fibre from polyetheretherketone polymer with high temperature and chemical resistance used in composites as a matrix material and in other industrial applications.

Polyetherimide fibre (PEI): A manufactured fibre spun from polyetherimide polymer having high temperature resistance, excellent processibility, and toughness. Used for matrix materials in composites and in other industrial applications.

Polyethers: By the polymerization of ethylene oxide we obtain the simplest type of aliphatic polyethers, polyethylene oxides (Polyglycol ethers; Polyethylene glycol), which also includes, for example, polyvinyl ethers. Aromatic polyethers usually contain built-in benzene cores. Linear aliphatic and aromatic polyether with a melting point of approx. 130–150°C possess the ability to form synthetic fibres.

Polyethersulfone fibre (PES): High molecular weight fibres from polymers containing sulphone ($-\text{SO}_2-$) groups and aromatic nuclei. They demonstrate high thermal stability and chemical inertness.

Polyethylene: $(-\text{CH}_2-\text{CH}_2-)_n$. A synthetic “olefin” polymer (plastic) Polyethylene, particularly high-density polyethylene (HDPE), is a good choice for containers for many dyeing processes. It has good chemical resistance,

but generally should not be subjected to boiling water (see polypropylene for an alternative). A great deal of the commercial packaging for household chemicals and food products is made from polyethylene. Some fabric sizing compounds and softening compounds are polyethylene derivatives.

Polyethylene emulsions: Polyethylene emulsions dry down to form hard, waxy films. When the emulsion is applied to fibres, a waxy coating deposits on the surface reducing its coefficient of friction. These coatings offer good protection against needle cutting and thread breakage and improve abrasion resistance and tearing strength. To be emulsifiable, the polyethylene polymer is first oxidized by passing air through the melt. Oxidation converts some polymer end groups to $-\text{COOH}$ and the quantity of carboxyl groups is controlled. Both low and high density polyethylene are processed this way. A number of grades of polyethylene polymers are available differing in melting point, melt viscosity, molecular weight and carboxyl content. Dispersions with anionic, nonionic and cationic character are made by selecting appropriate auxiliary emulsifier. Selecting an emulsion with the proper ionic character is important otherwise the finishing bath will become unstable and break out. Stable water emulsions with solids up to 20% are commercially available. The alkali salt of the polymer's carboxyl group is an important factor in the stability of the dispersions.

Polyethylene fibre: A manufactured fibre made of polyethylene, often in monofilament form as well as continuous filament yarns and staple. Ethylene is polymerized at high pressures and the resulting polymer is melt spun and cold drawn. It may also be dry-spun from xylene solution. Characteristics: Polyethylene fibres have a low specific gravity, extremely low moisture regain, the same tensile strength wet and dry, and are resistant to attack by mildew and insects. These qualities have made polyethylene fibre suitable for industrial applications, geotextiles, outdoor furniture, and similar applications. Polyethylene fibre does not dye, and in most cases, it is coloured by the addition of pigments and dyes to the material prior to spinning. It has a low melting point, a property that has restricted its use in apparel.

Polymer: A substance composed of long chain molecules, sometimes with more than 1000 atoms, and built up from simple molecules (monomers) linked together. Many are synthetic, but they may be of natural origin, such as *cellulose*. Different polymers may be formed from different unions of one monomer, so that they have the same formula but different linkages.

Polypropylene, PP: A *thermoplastic* material that is commonly used for food packaging. It is also used as a membrane for *microfiltration*. Its tolerance to chlorine is limited.

Polythene fibre: See *Polyethylene fibre (Olefin)* (a) high-density polyethylene (HDPE), 0.96g/m², produced by low-pressure polymerisation; and (b) low-density polyethylene (LDPE), 0.93g/m², produced by high-pressure polymerisation.

Polyethyleneglycols: Higher molecular weight polyoxyethylene analog are wax-like.

Polyethylene glycol esters: Polyethylene glycol esters of fatty acids have wax like properties.

Polyethylene glycols: Similar to diglycol or triglycol, for example, etherification product of several glycerol molecules in linear structure or in the form of complex polymers. Also mixed glycol-glycerol ethers, which become more similar to higher Polyethylene glycols with increasing oxyethylation. Like Glycerol, proposed for dyeing and printing purposes.

Polyfunctional: Multiple actions, e.g. a chemical compound with several Functional groups, or a multipurpose machine.

Polyglycol ethers: Addition products of ethylene oxide (ethylene oxide addition products) to fatty alcohols, fatty acids, amines, alkyl phenols, alkyl naphthols, etc. Polyglycol ethers form the group of non-ionogenic surfactants. A cationic character is also possible, because the water molecules, in aqueous solution with the residual valency of its atoms, attach to the residual valencies of the ether oxygen atoms. This additive compound then stabilizes to form co-ordination compounds. Polyglycol ethers are textile auxiliaries and due to their chemical resistance are often used as wetting, dispersing, levelling, stripping and, above all, washing agents, as well as emulsifiers and scrooping agents.

Polyhydroxyl fibres: Fibres, which have hydroxyl groups as prosthetic groups, above all cellulose and cellulose regenerate fibres, also appropriately modified synthetic fibres.

Polyimide fibre: See **Aromatic polyimide fibres**. An aromatic polyimide introduced by Upjohn Company for use in flame retardant, high-temperature applications. The fibre is spun from the polymer by wet or dry processing techniques using a polar organic solvent such as **N,N-dimethylformamide** to give a fibre with a round or dog-bone cross section. The highly coloured fibre may be crimped at 325°C using fibre relaxation. The fibre has a tenacity of 2-3 g/d (18-27 g/tex) and a 28%-35% elongation at break. The fibre has a moisture regain of 2.0%-3.0% and melts at about 600°C.

Polymannuronic fibre: Alginate fibre type, so called because Alginic acid represents a polymer dimannuronic acid (with pyranose structure).

Polymer: A macromolecular material formed by the chemical combination of monomers having either the same or different chemical combination. A compound in which there are very large molecules made up of repeating molecular units (monomers). A polymer has a repeated structural unit, known as a mer. Polymers do not usually have a definite relative molecular mass, because there are variations in the lengths of different chains. They may be natural substances (e.g. polysaccharides and proteins) or synthetic materials (e.g. nylon and polyethene). The two major classes of synthetic polymers are thermosetting (e.g. Bakelite) and thermoplastic (e.g. polyethene). The former are infusible, and heat may only make them harder, whereas the latter soften on heating. See **Polymerization**.

Polymer doping: It was found that polyacetylene manufactured according to the so-called Shirakawa process acquires a high electrical conductivity if it is brought into close contact with an oxidizing agent (in this case iodine). This process is now called doping, in an analogy to semiconductor physics. Conductivity rose by a billion fold compared to undoped polyacetylene.

Polymer etching: Low-pressure plasma can be used to chemically change the fibre surface. Oligomers are decomposed from the fibre surface in an inert gas plasma according to the following chemical mechanism (on polyester fibres). In a longer treatment (1 min) and high power input (in watts) the etching is

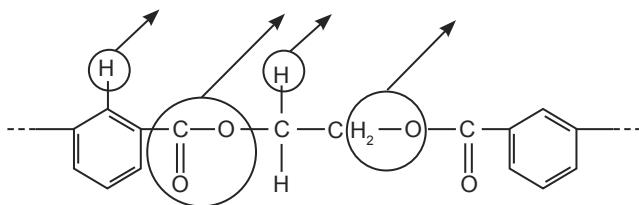

associated with a roughening of the fibre surface, increased refractive index and apparently darker colouring. Etching of wool fibre surfaces creates a sheen due to the partial removal of cuticle irregularities. In a longer treatment (1 min) and high power input (in watts) the etching is associated with a roughening of the fibre surface, increased refractive index and apparently darker colouring. Etching of wool fibre surfaces creates a sheen due to the partial removal of cuticle irregularities.

Polymerization: The process in which one or more compounds react to form a POLYMER. Homopolymers are formed by polymerization of one monomer (e.g. the formation of polyethene). Heteropolymers or copolymers come from two or more monomers (as for nylon). Heteropolymers may be of different types depending on the arrangement of units. An alternating copolymer of

two units A and B has an arrangement: $-A-B-A-B-A-B-$ A block copolymer has an arrangement in which blocks of one monomer alternate with blocks of the other; for example: $-A-A-A-B-B-B-A-A-A-$ In a graft copolymer there is a main chain of one monomer ($-A-A-A-A-$), with short side chains of the other monomer attached at regular intervals ($-B-B-$). Stereospecific polymers have the subunit repeated along the chain in a regular way. These are tactic polymers. If one particular group is always on the same side of the chain, the polymer is said to be isotactic. If the group alternates in position along the chain the polymer is syndiotactic. If there is no regular pattern, the polymer is atactic. Polymerization reactions are also classified according to the type of reaction. Addition polymerization occurs when the monomers undergo addition reactions, with no other substance formed. Condensation polymerization involves the elimination of small molecules in the formation of the polymer. See also **Cross linkage**.

Polymerisation, Emulsion: Emulsion polymerisation is a most widely used industrial technique. The monomers *e.g.*, butadiene, chloroprene, vinyl acetate, vinyl chloride, acrylates and methacrylates, etc., are used to polymerised by this method. A very high molecular weight product can be achieved by this technique. In this system, the monomer is dispersed in the aqueous phase as a uniform emulsion, and the emulsion is stabilised by surfactants (*i.e.*, surface active agents), protective colloids and by certain buffers.

Polymerisation, Group Transfer (GTP): Group transfer polymerisation (GTP) is a new technique of polymerisation. This process has few advantages over other, as it is found to impart perfect control in producing polymer chains with terminal functional groups. GTP does not require a very low temperature to bring about polymerisation. Many of the examples occur at room temperature. In this technique, initiator, generally organosilicon and a bifluoride catalyst is used. The monomers, *e.g.*, nitriles, α,β -unsaturated esters, carboxamides, ketones can be polymerised by this process. The formed polymer consists of the excellent yields with narrow molecular weight distribution.

Polymerization, Plasma: If gaseous, radical polymerizable gases (with double bonds in monomers) are allowed to flow into an evacuated plasma generating device, which contains synthetic fibres, and a plasma luminous discharge is generated, then plasma polymerization can be observed on the fibre surface by grafting:

More conductive fibres can be generated in this manner, for example by the grafting of organometallic polymers. Fire resistant textiles are created by the use of monomers containing phosphorus. Surface fluoridation is performed by first removing surface oligomers by argon etching, followed by impregnation with fluorocarbon monomers and finally grafting with CF_4 plasma gas.

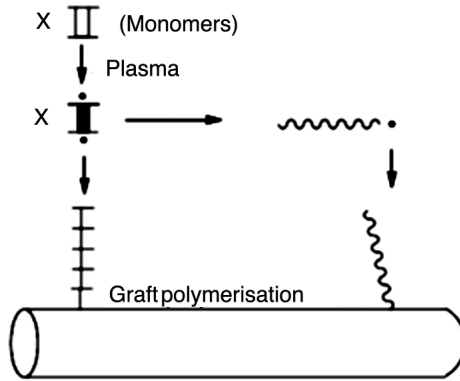

Polymerisation, Suspension: Suspension polymerisation is a heterogeneous system, where polymerisation proceeds to 100% conversion and the product is obtained as spherical beads or pearls. For this reason, this technique is known as beads or pearl polymerisation.

By this technique only water-insoluble monomers can be polymerised. In the form of fine droplets, the monomer molecules are suspended in water and mixed with surface active agents and water-soluble protective colloids. During polymerisation process, stirring remains continue. The initiators are monomer soluble. The continuous aqueous phase separating the monomer droplets acts as an heat transfer medium and hence the exothermicity is quite under control.

Polymerization cross-linker: Reactive compounds, which are capable of polymer formation and cellulose cross-linking, e.g. N-methylol acrylamide, N-methylol methacrylamide, N-methylol polyethylene urea. They yield a favourable ratio of resistance to tearing and abrasion in Resin finishing.

Polymerisation fibres: Extensive main group of synthetic fibres, the macromolecule of which contains the same or different continuous long carbon chains, formed by Polymerization, which is unique to all polymerization fibres (unlike Polycondensation fibres), and which differ from each other due to side chains containing other foreign atoms (chlorine, fluorine, cyanogen, etc.) or groups ($-\text{CH}_3$, $-\text{OH}$, $-\text{CONH}_2$). This group includes e.g. polyacrylonitrile fibres, polybutadiene fibres, polyolefin fibres, polystyrene fibres, polytetrafluorethylene fibres, polyvinyl alcohol fibres, polyvinylacetate fibres, polyvinylchloride fibres, polyvinyl fluoride fibres, polyvinylidene cyanide fibres, polyvinyl copolymerization fibres.

Polymerization products: (polymerizate, polymerized synthetic resins, polymerization plastics), products of Polymerization, either in the form of

Plastics or Synthetic resins, e.g. : Polyacrylic acid; Polyacrylic acid ester; polyacrylates; Polyacrylonitrile; polybutadiene; Polychlorobutadiene; Polyethylene; Polyisobutene; Polymerization fibres; Polymethacrylic acid ester; Polystyrene; Polytetrafluorethylene; polyvinyl alcohol; Polyvinyl ethers; Polyvinyl acetals; Polyvinyl chloride; Polyvinylidene chloride; Polyvinylpyrrolidone.

Polymerise: To undergo polymerization. To react molecules resulting in their combining and forming relatively long-chain, large molecules.

Polymethacrylic acid (PMAA): Poly(methacrylic) acid is completely water soluble and functions as a soil release finish. However the proper amount of cross-linking is necessary before the finish to functions properly. Table 9 shows that the soil release rating are influenced by the inclusion of a diepoxide crosslinking agent. When PMAA is crosslinked with only the diepoxide, marginal SR ratings are obtained. However if a small amount of diepoxide is added with DMDHEU, the soil release ratings are vastly improved. Increasing the amount of diepoxide causes the SR rating to drop again. This data supports the contention that the ultimate properties of the cured film deposited on the surface of the fibre determines soil release.

Polynosic: Derived from the French “polymère non synthétique” (non-synthetic polymer). Since 1961 the trade name, protected by trademark law, has been “Association Internationale Polynosic” – members for Polynosic fibres. The scope of protection is controversial, because countries with a fibre declaration of “polynosic” do not recognize it as a generic term. The trademark associated with certain modal fibres, it is a manufactured cellulosic fibre with properties similar to cotton, but the fibres are softer. Modified viscose fibres, subgroup of the cotton-like Modal fibres. Differ from High wet modulus fibres due to their good alkali resistance (mercerizability). They possess a characteristic uniform structure of fine fibrils in a rather homogeneous arrangement distributed over the entire round cross-section. Therefore, they have good penetration and reactivity at low swelling (approx. 60%) compared to finishing resins. They have good dimensional stability due to the high wet modulus. The fibre is more difficult to dye than cotton. Polynosic is often mixed with cotton and other fibres.

Polynosic fibre: A regenerated cellulose fibre that is characterised by a high initial wet modulus of elasticity and a relatively low degree of swelling in sodium hydroxide solution.

Polyolefin: Any long chain synthetic polymer composed of at least 85 weight % of ethylene, propylene or other olefin units (monomers), except amorphous (noncrystalline) polyolefin qualifying under Rubber.

Polyolefin fabric: A fabric woven from polyolefin monofilaments.

Polyolefin fibre: See **Polyolefin**.

Polyolefin fibre: A fibre made from a synthetic linear polymer obtained by polymerising an unsaturated hydrocarbon (e.g. ethylene $\text{CH}_2=\text{CH}_2$ or propylene $\text{CH}_2=\text{CH}-\text{CH}_3$) to give a linear saturated hydrocarbon. A polyolefin fibre is generally defined as a manufactured fibre in which the fibre forming substance is any long chain synthetic polymer compound of at least 85 % by weight of ethylene, propylene, or other olefin units except 'amorphous' (non-crystalline) polyolefins qualifying under rubber. (See also polyethylene fibre and polypropylene fibre, rubber.)

Polyolefin monofilament: A flat single filament of the slit film type, which can function as yarn in commercial textile operations.

Polyoxyamide fibre: Copolymeric fibre with good comfort properties, particularly high moisture absorption and transfer, and intrinsic softness.

Polyoxyethylene thioether: Surfactant of polyoxyethylatedthioether type.

α -polyoxymethylene: $\text{HO}-\text{CH}_2-\text{O}-(\text{CH}_2-\text{O})_x-\text{CH}_2-\text{OH}$, a polyoxymethylene-dihydrate with DP = 2 to above 100, reductive action, is split by sodium sulphite.

γ -polyoxymethylene: $\text{H}_3\text{C}-\text{O}-\text{CH}_2-\text{O}-(\text{CH}_2-\text{O})_x-\text{CH}_2-\text{O}-\text{CH}_3$, a polyoxymethylene-dimethylether, DP = 2 to above 100, no longer has reductive action, no splitting by sodium sulphite.

Polyphosphates: Phosphates with varying degrees of condensation and a chain-shaped molecular structure. Diphosphate (= pyrophosphate = two chain), triphosphate (= tripolyphosphate = three chain), tetraphosphate (= tetrapolyphosphate = four-chain), etc. up to high molecular polyphosphates = Graham's salt ($25\text{Na}_3\text{PO}_4$). When dissolved in water, polyphosphates show the typical behaviour of complex formers. They dissociate max. at 30%. In water softening (i.e. bonding e.g. of calcium ions) initially non-dissociated sodium atoms (or H atoms in polyphosphoric acids) are continuously exchanged. The solubility of the complex salts decrease with increasing calcium content. If there are excess calcium ions, dissociated sodium ions are also replaced by calcium and water insoluble calcium polyphosphates. It follows from this that polyphosphates must always be dosed in a certain stoichiometric excess, in order to obtain soluble calcium (or other metal) complexes. Application: for masking water hardness and heavy metal ions, in washing, bleaching, dyeing, printing, resin finishing, as a component of domestic and industrial washing agent. The following general structural formula applies for polyphosphates:

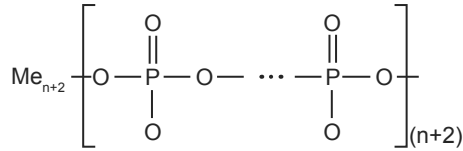

Polypropylene: A synthetic “olefin” polymer (plastic).

Polypropylene fibre: $\{-\text{CH}_2-\text{CH}(\text{CH}_3)-\}_n$ Polypropylene containers are a good choice for many dyeing processes. Polypropylene has excellent resistance to most chemicals used in dyeing, with the possible exception of some disperse dye carriers. It can be used at the boiling point of water, though it can't be used on a stove top. A great many household plastic containers are made from this polymer. Polypropylene is also used for fibres, mostly for carpets, but finds some use in garments. It cannot conventionally dyed so it is coloured by “dope dyeing” (pigments are added to the raw material). A manufactured, olefin fibre made from polymers or copolymers of propylene. Polypropylene fibre is produced by melt spinning the molten polymer, followed by stretching to orient the fibre molecules. Characteristics: Polypropylene fibres have a number of advantages over polyethylene fibres in the field of textile applications. The degree of crystallinity, 72 to 75%, results in a fibre that is strong and resilient, and does not fibrillate like high-density polyethylene.

Polypropylene has a high work of rupture, which indicates a tough fibre, and may be made with tenacities as high as 8.0 to 8.5 grams per denier. The melting point of polypropylene is 165°C, which is low by comparison with nylon or polyester, but is high enough to make it suitable for most textile applications. So light that it actually floats, polypropylene fibre provides greater coverage per pound than any other fibre. It is highly resistant to mechanical abuse and chemical attack. Uses: Polypropylene fibres are widely used in industrial, carpet, and geotextile applications. They have found important uses in fishing gear, in ropes, and for filter cloths, laundry bags and dye bags. The excellent chemical resistance of polypropylene fibre is of advantage in the filtration and protective clothing fields. Fibrillated polypropylene yarns are widely used in indoor-outdoor carpets. Staple fibre finds application in blankets, pile fabrics, underwear, and industrial fabrics; it is being developed for carpets, candlewicks, knitted outerwear, hand-knitting yarns, and upholstery.

Polypropylene glycol: Colourless, non-volatile, does not corrode metals, highly to slightly soluble in water, cold resistant. Application: for lubricants, solvents, non-ionogenic cleaning products, synthetic resins, softeners, etc.

Polyreflets: French plush having patterns produced by the inclination of the pile at different angles.

Polysaccharide: A high-molecular-weight polymer of a monosaccharide. The polysaccharides contain many repeated units in their molecular structures. They can be broken down to smaller polysaccharides, disaccharides, and monoisotactic saccharides by hydrolysis or by the appropriate enzyme. Bio-polymers made up of ten or more simple sugar (like glucose) units Starches and cellulose are polysaccharides. (Below 10 sugar units, a specific numerical prefix is usually used, such as in “disaccharide”.) Important polysaccharides are heparin, inulin, starch, glycogen (sometimes known as animal starch), and cellulose. See also **Carbohydrates; Sugar**.

Polysalts: See **Polyelectrolytes**.

Poly-set-process: Two-stage Permanent-press process: Stage I cross-linking in the presence of weak catalysts such as zircon acetate. Stage II after manufacture using strong catalysts such as zinc nitrate.

Polysilicic acids: Higher Silicon oxo acid e.g. of the type $(\text{H}_2\text{SiO}_3)_n$, the most well-known salt of which is water glass or Sodium silicate.

Polysiloxane polymers: See **Silicons**.

Polystyrene: A synthetic polymer made from styrene (phenylethene). Expanded polystyrene is a rigid foam used in packing and insulation.

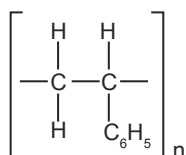

Polystyrene fibres: Synthetic polymer (plastic) Polystyrene is extensively used for disposable food service and packaging items. Solid polystyrene is used for disposable cutlery, glasses and portion cups. Foamed polystyrene is used for plates, packaging trays, coffee cups and the like. Polystyrene has poor resistance to many organic chemicals. Do not use it for storage of dry dyes. Polystyrene items are very convenient for short-term handling dye powders when weighing or mixing dyes.

Polysulphonated dyes: See **Acid dyes**.

Polytetrafluoroethylene fibre (PTFE): Fluorine-containing manufactured fibres characterized by high chemical stability, relative inertness, and high melting point. Made by emulsion spinning, a process that essentially results in fusion of fibrils by passing an emulsion through a capillary, then drawing the resulting fibre. The fibre has a moderate tensile strength and is particularly resistant to the effect of high temperatures and corrosive chemicals. Having

very low frictional coefficients, it has a slippery hand. Its principal uses are in packaging and filtration media.

Polytetramethylene terephthalate fibre: Polyester modification, which can be dyed without a carrier, e.g. for domestic textiles. Density 1.31; melting point up to 224°C; glass transition temperature 40°C.



Polythioethers: Synthetic polymers with Thioethers (alkylpolysulphide), e.g. of type $[-\text{CH}_2\text{CH}_2\text{S}-]_x$. They form the basis for synthetic rubber like products and as synthetic fibre formers (Polymethylene sulphone fibres).

Polythioureas See **Polyureas**.

Polyureas: Organic conversion products of di-isocyanates and diamines, e.g.:

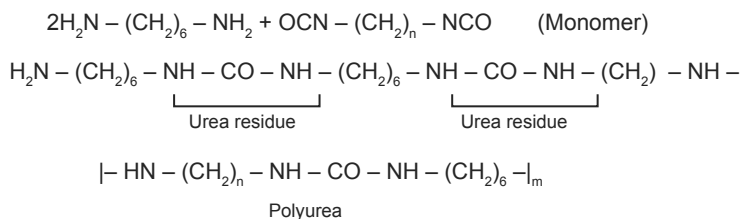

Application: adhesives, cements; animalization; hydrophobing; fibre material (Polyurea fibres); moulded plastics; synthetic leather, etc.

Polyurea fibres: Further development within the group Polyurethane fibres made of spun Polyureas as. The properties of the polyurea fibres largely correspond with those of polyurethanes, having the following advantages compared to the latter: Low density of 1.07 and significantly higher melting point of 237°C.

Polyurethane: A synthetic polymer containing the group $-\text{NH}-\text{CO}-\text{O}-$ linking the monomers. Polyurethanes are made by condensation of isocyanates ($-\text{NCO}$) with alcohols.

Polyurethane fibre: See **Spandex fibre**.

Polyurethane elastomeric fibres: These are, elastomer fibres made of high polymers, which consist primarily of segmented Polyurethanes. The elastomer behaviour owes its elastic stretchability to amorphous soft segments (60–80% by weight), and to crystalline hard segments (40–20% by weight) for chain coherency (elastane fibres). Polyurethane elastomer fibres have rubber-like high elasticity.

Polyurethane rubber: (urethane rubber), synthetic rubber based upon Polyurethane elastomer fibres.

Polyvinyl acetate: Thermoplastic synthetic polymer of vinyl acetate (produced from acetylene and acetic acid). Application: particularly for finishes (weighting, stiffening effects, hat stiffeners, ladder proof finishes, cheap coatings (synthetic leather, nitrate cellulose line end), laminating, pigment print pastes (production shortly before processing due to rapid hardening), lacquer raw material, adhesive, seam free floor covering.

Polyvinyl acetate fibres: Vinyl acetate is represented in copolymers with polyvinyl chloride and polyacrylonitrile fibres as a modification component. Polyvinyl acetate fibres can be dissolved.

Polyvinyl acetate sizes: Polyvinyl acetate, as waterproof sizes for polyester chains for use on water jet weaving machines. Properties: good water solubility and adhesiveness.

Polyvinyl alcohol: Polyvinyl alcohol is manufactured by hydrolysing polyvinyl acetate. The reason is because vinyl alcohol does not exist as a monomer, tautomerization favours the more stable acetaldehyde. Polyvinyl acetate, however, can be hydrolysed into polyvinyl alcohol under acidic or basic conditions. Either method leaves undesirable salts that are difficult to remove. The preferred commercial method of hydrolyzing polyvinyl acetate is to use catalytic amounts of sodium methoxide in methanol. The parent polyvinyl acetate forms branches during polymerization by a chain transfer mechanism at the methyl group of the ester. However, the corresponding polyvinyl alcohol is lower in molecular weight and virtually linear. The branch points are ester linkages which are broken during the hydrolysis step. The branches become linear, lower molecular weight fragments. This accounts for both lower molecular weight and the linearity of the PVA.

Polyvinyl alcohol fibre: A manufactured textile fibre developed in Japan. It is made by dissolving polyvinyl alcohol in hot water and extruding this solution through a spinneret into a sodium sulphate coagulating bath. In Japan, the fibre is used in apparel, household, and industrial fabrics.

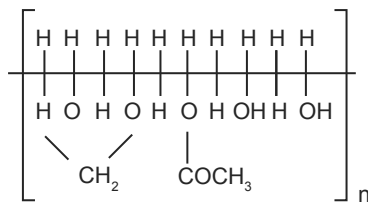

Polyvinyl chloride: A synthetic polymer (plastic) Polyvinyl chloride (PVC) is a very widely used plastic that varies from rigid to very flexible, depending

upon additives. It has quite good resistance to most dyeing chemicals, with the exception of carriers for disperse dyes. PVC pipe, intended for plumbing

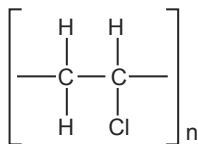

use, is popular for 'forms' around which to wrap fabric for direct dye application techniques such as shibori. Temperature resistance depends on additives and varies considerably. PVC is used extensively as water-proofing coatings on fabrics and for imitation leather.

Polyvinyl chloride fibres: Group of synthetic polymer fibres (the first commercially available synthetic fibres) made of at least 85% Polyvinyl chloride (if lesser proportion: Polyvinyl chloride copolymer fibres), which can also be post-chlorinated, whereby two polyvinyl chloride fibre types can be differentiated:

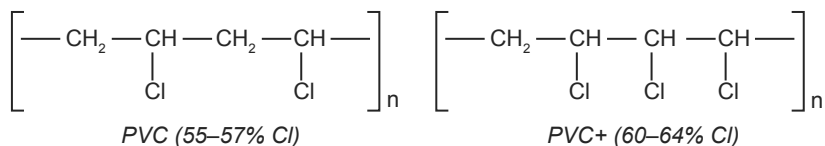

Polyvinyl chloride copolymer fibres: Vinyl chloride copolymers, group of modified polyvinyl chloride types in the form of multipolymer fibres. Application: technical fabrics, protective clothing; also heat-pressure welded with other fibres, however usually mixed due to low strength and high expansion (cotton, wool, viscose staple).

Polyvinyl ethanoate: See **Polyvinyl acetate**.

Polyvinyl ethers: Synthetic polymer of Vinyl ether. Particularly polyvinyl methyl ether. Soluble in water and organic solvents. Resistant to saponification. Reversible coagulation point at 30°C in aqueous solution. Generates full soft handle. Application: sizing agent, finishing agent, printing thickeners (organically soluble); adhesive; lacquer raw material; softener for nitrate cellulose.

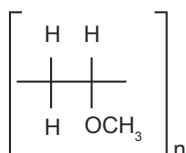

Polyvinyl fluoride: Polymerized vinyl fluoride, produced from acetylene and hydrogen fluoride (polymerization at 810 bar). Polyvinyl fluoride fibres are

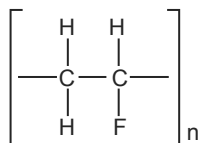

produced in the melt spin process and drawn (100%). Properties: melting point 175–200°C; softening point 130°C; temperature resistance and shrinkage are superior to those of polyvinyl chloride fibres, as is their resistance to light and chemicals; insoluble in xylene; very difficult to dye (thus spin-dyeing). Dyed polyvinyl fluoride is used as a heat resistant fibre glass application.

Polyvinyl formal fibres: Polyvinyl alcohol fibres that are subsequently hardened with formaldehyde (degree of formalization approx. 35–45% of the OH groups) are also termed polyvinyl formal fibres.

Polyvinylidene chloride: Synthetic polymer; of asymmetric dichloro ethylene, produced by, e.g. chlorinated vinyl chloride and HCl splitting. Application: emulsion for lacquer, adhesive, for coating; (acrylonitrile copolymer:) acid resistant pipe and container lining, also tank linings for benzene and petroleum products See **Polyvinylidene chloride fibres**.

Polyvinylidene chloride fibres: See **Polyvinylidene chloride**. Synthetic polymer fibres of min. 80% vinylidene chloride. When spun and drawn, such polyvinylidene chloride fibres mainly form horsehair-like monofilaments (for wear-resistant cushion and grille cloths, filter cloths, sieve fabrics, conveyor belts, ropes, bristles, decorative materials) and also for continuous filament yarn and smooth and curly fibres (for nonwovens, technical felts, upholstery and grille cloth, blankets, carpets, etc. Properties (largely similar to polyvinyl chloride fibres, superior, e.g. against solvents, more recent polyvinylidene chloride fibres also in thermal behaviour): Density 1.65–1.75; normal moisture 0–0.1%; strength dry/wet 13–21 cN/tex; elongation, dry/wet 20–30%; difficult to burn, dirt repellent, resistant against mildew and bacteria, good resistance against cold acids (except H₂SO₄ conc.), alkalis (except concentrated) and most organic solvents including acetone (if they contain oxygen, e.g. dioxane, there is a swelling or softening effect); heat resistance differs depending upon origin: shrinks even at 60–75°C (softens at 90–135°C), sometimes boiling resistant, softens at 115–140°C, shrinking range starts at 145–155°C and melting point 150–175°C. Chlorine resistance poor; dyeable with disperse dyes. Detection: Morpholine test.

Polyvinyl derivatives: They are polymerization products of vinyl derivatives, which have in common the vinyl group $\text{CH}_2=\text{CH}-$ (polyvinyl group: $-\text{CH}_2\text{CH}-$). Normally called plastics or synthetic resins. Important polyvinyl derivatives are $\text{CH}_2=\text{CH}-\text{CH}=\text{CH}_2$ divinyl (butadiene), $\text{CH}_2=\text{CH}-\text{C}\equiv\text{CH}$ vinyl acetylene, $\text{CH}_2=\text{CH}_2$ ethylene, $\text{CH}_2=\text{CH}-\text{HCO}$ acrolein $\text{CH}_2=\text{CH}-\text{Cl}$ vinyl chloride, $\text{CH}_2=\text{CH}-\text{F}$ vinyl fluoride, $\text{CH}_2=\text{CH}-\text{OH}$ vinyl alcohol (unstable) $\text{CH}_2=\text{CH}-\text{OCOCH}_3$ vinyl acetate, $\text{CH}_2=\text{CH}-\text{OCH}_3$ vinyl methyl ether, $\text{CH}_2=\text{C}(\text{CH}_3)_2$ isobutylene, $\text{CH}_2=\text{CH}-\text{C}_6\text{H}_5$ styrene (vinyl benzene), $\text{CH}_2=\text{CH}-\text{CN}$ acrylonitrile (vinyl cyanide), $\text{CH}_2=\text{CHCOOH}$ acrylic acid, $\text{CH}_2=\text{CH}-\text{COOCH}_3$ methacrylic acid ester $\text{CH}_2=\text{C}-\text{CH}_3\text{COOH}$ methacrylic acid, $\text{CH}_2=\text{C}-\text{CH}_3\text{COOCH}_3$ methacrylic acid methyl ester.

Polyvinylidene dinitrile: (polyvinylidene cyanide, ethylidene dicyanide, 1,1-icyanoethene), synthetic polymer of vinylidene cyanide. Used as copolymer (vinylidene cyanide/vinyl acetate 1 : 1) for the production of Polyvinylidene dinitrile fibres.

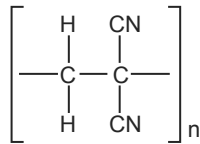

Polyvinylidene dinitrile fibres: (dinitrile fibres), copolymer fibres of type polyvinylidene dinitrile, 50–230% drawn, cashmere-like character. Properties: cross-section kidney shaped, density 1.18; normal moisture take-up 2–3%; softening point 171–176°C; melting point 175°C; breaking strength 20–40 cN/tex (wet 15 cN/tex); elongation at break dry/wet 30–35%; burnable similar to cotton; good weather resistance; good resistance against mildew, rotting, insects; low shrinkage even after repeated boiling wash (max. 1%); Application: pure or mixed (wool, cotton), particularly for knitgoods, high quality pile fabrics (e.g. imitation fur coat materials, downy soft, elegant fall, no pilling), for nonwovens, etc.

Polyvinylidene group: ($-\text{CH}_2-\text{CR}_2-$); See **Polyvinylidene chloride** ($\text{R} = \text{Cl}$); see **Polyvinylidene Dinitrile** ($\text{R} = \text{CN}$).

Polyzymes: Amylases, belonging to the class of bacterial enzymes, however not so heat resistant; effectiveness from 40°C; high liquefaction power, low saccharification power for starches. Bred from cultures of *aspergillus oryzae* on wheat germ.

Pompadour: A silk term for small floral effects.

Pompadour Serge: English woollen serge with small flower patterns.

Poncho: (1) A narrow woollen blanket, made with cotton warp and woollen filling napped and well filled, being made quite waterproof; used in camping; (2) Cotton or woollen fabric, made in plain, twill or rep weave with fringes at the ends, usually with coffee brown stripes; used as overcoat in Argentine, Uruguay and Paraguay, having a slit in the centre for the head.

Pond: No longer permissible unit of force. SI unit is Newton. Conversion: 1 p = 9.80665 mN; 1 kp = 9.80665 N.

Pongee (silk): Greige warp, greige or tram weft. Fabric has discrete lustre. Habota's silks are mostly light fabrics 30-60 g/m², often known as pongee.

Pongee (ponge): The word pen-chi, from which pongee has been derived, was originally the name of a Chinese silk. Tussah silk was used for the fabric and was normally woven on hand looms. Light silk fabric of slightly rough feel with excellent draping qualities, but it may now be acetate, triacetate, nylon, or other fibres, all resembling the silk fabric in weight and handling. It is plain weave material notable for its high lustre. Its weight ranges from light to medium. And may be plain dyed or printed. Uneven yarns are used in the cloth and there are usually more picks than ends. Used for blouses, soft dresses, nightwear, and in plain colours as a lining fabric. A typical rayon pongee will have a construction of 64 × 72 with 50s in the warp and 30s in the filling. It is finished usually at 38 in. width and weighs around 3½ oz. per sq. yard.



Ponge venezia

Pongee Imperial: A rich, plain woven and highly finished silk dress goods, made of pongee silk.

Pongee Print: A fine and light cotton goods with a soft finish, printed with stripes and dots; used in South Africa.

Ponson Velvet: Heavy velvet, made all silk or only with silk pile; used for women's coats and cloaks.

Ponte di Roma: A common double-knit fabric construction with a four-feed repeat produced with the dial and cylinder needles in interlock gaiting. The fabric is plain and looks the same on both sides.

Pontiac: Dark grey, stoutly knitted and waterproof woollen fabric; used for skirts and coats for outdoor wear.

Poodle cloth: A medium or heavy fabric characterized by loops of yarn on the surface. It may be wool, acrylic or other yarns or mixtures. Mohair is also sometimes included. It is in plain colours or random effects. Used for jackets or coats and warm dresses.

Pooling: See **Pile reversal**.

Poor appearance: Small blemishes that individually do not warrant a string (q.v.) but that, when the fabric is assessed overall, render it unacceptable (in part or in whole).

Poor cover: A faulty fabric in which the warp or weft yarns show through the covering yarns when not so required by the construction.

Popcorn: (1) A special-effect yarn containing short, thick spots. (2) In polymer manufacture a term used to describe oversize, deformed chip.

Poplin: The name poplin comes from the word papaline, fabric made in the papal town of Avignon, France. It was used for church vestment and hangings. The material is somewhat like broadcloth, but fewer picks per inch and heavier yarn is used for filling. A characteristic construction may be 100 x 40 with 40s warp and 20s filling. All rayon, poplin is made in textures ranging from 80 x 40 to 100 x 50 with warp of 75, 100, 120, or 150 denier rayon and filling 150, 200, 250 or 300 denier rayon. Typical texture may be 92 x 40 with 150 denier warp and 300 denier filling. Even 2/30s or 3/40s cotton or spun synthetic can be used along with 150 denier rayon. Poplins are usually mercerized and then chased for the lustrous appearance. It may be bleached, dyed or printed. It is used for blouses, shirts, gowns, robes, children's suits, rain wear and draperies, and finishes are given according to these end uses. It creases in wear, although less so if some polyester yarn has been included. It is in plain colours or prints, and is very hard wearing, comfortable and absorbent.

Poplin, single, ply, semi: All these are poplins the names derived from the type of yarn used.

Poplinette: Lightweight single poplin is called poplinette. A variety of grenadine, similar to a very light poplin.

Porcelain Lace: Lace steeped in thick solution of kaolin and fired which destroys the fibres but leaves the porcelain behind.

Porcelain printing: In hand printing with zinc plate screens small white, plastic dot patterns applied to dark coloured, usually black, silk.

Pore size of fibres: Pore size can be explained as the the intermicellar gaps (crystallite) of the Pore volume of textiles. The pore pore width of cellulose fibres is approximately 0.6 nm in dry state and in aqueous swollen state it is around 4–6 nm. In swollen cellulose acetate we can only expect pore widths of 5–6 nm. The ratio of pore widths in dry and swollen wool is around 0.6 : 4 nm. The significantly more compact synthetic fibres with their low water take-up or water swellability only achieve pore sizes up to around 0.8–1 nm even in aqueous wetted state.

Pore volume of textiles: The pore volume of textile fabrics is calculated as follows:

$$\frac{\text{density} - \text{volumetric weight}}{\text{density}} \times 100\%$$

Usually, porosity is made up of three elements: porosity within the fibres, so-called intrafibrillary porosity, porosity between the individual fibres, so-called interfibrillary porosity, the gaps between the yarn threads, so-called yarn porosity.

Porosity: The ratio of the volume of air or void contained within the boundaries of a material to the total volume (solid matter plus air or void) expressed as a percentage. Porosity = $V_1 \times 100/V_2$ where V_1 = Volume of voids, V_2 = Total volume.



Fabric porosity: the fabric is a porous plate, while the threads are solid.

Port Cabello: Raw cotton from Colombia.

Port Philip: Fine Australian merino wool.

Portal steamer: Continuous steamer for single or two-phase printing, combined underfloor/elevated machine type with oil heated steamer cover. Spiral-shaped roller arrangement in narrow arch or channel shape, without deflecting bar. Guaranteed freedom from drips, air and folds. For pile and stretch fabrics; material guidance usually from inside to outside; water stabilization gates for slow cooling off of polyacrylonitrile pile, also warm air gates. All rollers are driven. The spiral-shaped material flow has proved particularly beneficial when used on a continuous production line, e.g. for printing after-treatment or pile fabric dyeing, thus in continuous dyeing. Material content single track 45–170 m, multitrack correspondingly greater content.

Portuguese Stem Stitch: An embroidery stitch. Commence as for ordinary stem stitch. Pull the thread through and pass the needle under the stitch just made, without entering the fabric. Then pass the needle under the same stitch below the first coll. And make another stem stitch. Pass the needle twice under the stitch just made and under previous stitch.

Positive Feed, in knitting: When the yarn is metered off the warp beam by a metering device.

Post Bed: A bed incorporating a raised post underneath the sewing head which enables sewing to be carried out above the level of the table on which the machine is mounted.

Post-curing: Various called delayed and deferred curing: Permanent-press process.

Post-mercerising: The abrasion resistance of linen cloth with an anti-crease finish can be significantly improved by mercerization after the hardening of the synthetic resin.

Post-purchase feeling: How a purchaser feels after purchasing something.

Poster Rug: Woven of rags with white warp, having borders in several colours, showing landscapes, flowers, etc.

Pot: A length of usually 10,000 yards, into which pieces of linen are sewed together previous to bleaching.

Pot spinning: A method formerly used for making viscose rayon. The newly spun yarn was delivered into the center of a rapidly rotating, centrifugal pot, where it received twist and centrifugal force caused it to go to the wall of the pot. The yarn package so formed was called a cake.

Potash: A common name for potassium or potassium compounds. Generally used to mean potassium carbonate.

Potash alum: Aluminium potassium sulphate.

Potassium bitartrate: (cream of tartar, potassium tartaric acid, double potassium tartaric acid), $C_4H_5O_6K$, molecular weight 188. Slightly soluble in cold water, better in hot water. Application: No longer used.

Potassium carbonate: (pearl ash; potash) It is used in the laboratory as a drying agent. (carbonate of potassium, potash), $K_2CO_3 \cdot 2H_2O$. Molecular weight 174. A translucent (granular) or white (powder) deliquescent solid known in the anhydrous and hydrated forms. K_2CO_3 (monoclinic; r.d. 2.4; m.p. 891°C) decomposes without boiling. $2K_2CO_3 \cdot 3H_2O$ (monoclinic; r.d. 2.04) dehydrates to $K_2CO_3 \cdot H_2O$ above 100°C and to K_2CO_3 above 130°C.

It is prepared by the Engel Precht process in which potassium chloride and magnesium oxide react with carbon dioxide to give the compound **Engel's salt**, $\text{MgCO}_3 \cdot \text{KHCO}_3 \cdot 4\text{H}_2\text{O}$. This is decomposed in solution to give the hydrogencarbonate, which can then be calcined to K_2CO_3 . White (anhydrous) granular powder or crystalline mass, both hygroscopic, deliquescent, water soluble, solution strongly alkaline. Application: Milder alkali than sodium carbonate, particularly for wool treatment, in printing, as soap component, etc.

Potassium chlorate: (chlorate of potassium), KClO_3 , molecular weight 122.5. A colourless crystalline compound, KClO_3 , which is soluble in water and moderately soluble in ethanol; monoclinic; r.d. 2.32; m.p. 356°C ; decomposes above 400°C giving off oxygen. The industrial route to potassium chlorate involves the fractional crystallization of a solution of potassium chloride and sodium chlorate but it may also be prepared by electrolysis of hot concentrated solutions of potassium chloride. It is a powerful oxidizing agent finding applications in weed killers and disinfectants and, because of its ability to produce oxygen, it is used in explosives, pyrotechnics, and matches and particularly for textile printing and aniline black dyeing.

Potassium chromate: (potassium chromic acid, potassium mono chromate), K_2CrO_4 , molecular weight 194.5. A bright yellow crystalline solid, soluble in water and insoluble in alcohol; rhombic; r.d. 2.73; m.p. 968.3°C ; decomposes decomposes without boiling. It is produced industrially by roasting powdered chromite ore with potassium hydroxide and limestone and leaching the resulting cinder with hot potassium sulphate solution. Potassium chromate is used in leather finishing, as a textile mordant, and in enamels and pigments. In the laboratory it is used as an analytical reagent and as an indicator. Like other chromium(III) compounds it is toxic when ingested or inhaled.

Potassium dichromate: (bi-chromate of potash, Red bi-chromate of potash; double bi-chromate of potassium, potassium bichromate), $\text{K}_2\text{Cr}_2\text{O}_7$, molecular weight 294.5; density 2.7. An orange-red crystalline solid, anhydrous and dry, stable in air, toxic, water soluble, solution weakly acidic, possesses oxidation property, insoluble in alcohol; monoclinic or triclinic; monoclinic changes to triclinic at 241.6°C ; m.p. 396°C ; decomposes above 500°C . It is prepared by acidification of crude potassium chromate solution (the addition of a base to solutions of potassium dichromate reverses this process). The compound is used industrially as an oxidizing agent in the chemical industry and in dyestuffs manufacture, in electroplating, pyrotechnics, glass manufacture, glues, tanning, photography and lithography, and in ceramic products. Laboratory uses include application as an analytical reagent and as an oxidizing agent. Potassium dichromate is toxic and considered a fire risk on account of its

oxidizing properties. Application: after treatment of chrome development dyes to improve fastness; dye mordant for wool; component of metachrome mordant; oxidizing agent for the development of fast dyeing and printing; vigorous decolorizer for wool.

Potassium ferricyanide: See **Potassium hexacyanoferrat III.**

Potassium ferrocyanide: See **Potassium hexacyanoferrat II.**

Potassium hexacyanoferrat II: (yellow prussiate of potash, yellow potassium prussiate), $K_4[Fe(CN)_6] \cdot 3H_2O$. Light yellow crystals, stable in air, water soluble, insoluble in alcohol and ether. Application: Iron indicator.

Potassium hexacyanoferrat III: (red prussiate of potash, red potassium prussiate), $K_3[Fe(CN)_6] \cdot H_2O$. Red crystals; break down in sunlight, gradually decomposing to potassium hexacyanoferrat(II) (yellow prussiate of potash) due to the separation of iron(III) hydroxide; strong oxidizing agent. Application: discharge printing, in analytic chemistry as an iron indicator.

Potassium hexafluorozirconate: (potassium fluorozirconate). K_2ZrF_6 . White crystals, soluble in hot water. Application: IWS flame retardant finish for wool.

Potassium hydroxide: (caustic potash, potash lye), KOH. Molecular weight 56, density 2.04. White, highly caustic crystal mass (K_2O) or pieces, fragments, plates, powder; highly hygroscopic (eagerly attracts water and carbon dioxide, therefore store in sealed container); readily deliquescent, readily water soluble and in ethanol and very slightly soluble in ether; or viscous lye, strongly alkaline, strongest dissociated base; rhombic; m.p. $360.4^\circ C$; b.p. $1320^\circ C$. It is prepared industrially by the electrolysis of concentrated potassium chloride solution but it can also be made by heating potassium carbonate or sulphate with slaked lime, $Ca(OH)_2$. It closely resembles sodium hydroxide but is more soluble and is therefore preferred as an absorber for carbon dioxide and sulphur dioxide. It is also used in the manufacture of soft soap, other potassium salts, and in Ni-Fe and alkaline storage cells. Potassium hydroxide is extremely corrosive to body tissues and especially damaging to the eyes.

Potassium iodide starch paper: Filter paper, which is soaked in boiled starch paste and 3–5 g/l potassium iodide before drying. Application: (a) Detection of traces of free chlorine (in bleaches, etc.) = wetted material is dark blue. (b) Detection of acid traces on cellulose goods = dark blue colouring. (c) Testing of diazotization baths (detection of free nitrous acids), if no blue colouring occurs then there is no nitrite or acids. Principle: released iodide determines the formation of blue iodide starch.

Potassium percarbonate $K_2C_2O_6$: Molecular weight 198.3. Bleaching agent and component of oxidative washing agents.

Potassium permanganate: potassium manganate(VII): KMnO_4 , a compound, forming purple crystals with a metallic sheen, soluble in water (intense purple solution), acetone, and methanol, but decomposed by ethanol; Density 2.70; decomposition begins slightly above 100°C and is complete at 240°C . The compound is prepared by fusing manganese(IV) oxide with potassium hydroxide to form the manganate and electrolyzing the manganate solution using iron electrodes at about 60°C . An alternative route employs production of sodium manganate by a similar fusion process, oxidation with chlorine and sulphuric acid, then treatment with potassium chloride to crystallize the required product. Potassium manganate(VII) is widely used as an oxidizing agent and as a disinfectant in a variety of applications, and as an analytical reagent. Application in textile: potassium permanganate is a powerful oxidizing agent which has been used in garment washing indigo-dyed denim to produce a worn, faded appearance. It has also found some use in discharge printing of indigo. It is no longer favoured by industry because of environmental concerns. It is quite hazardous, and can be caustic to skin. Care must be used when mixing it with organic materials because it can cause spontaneous combustion.

Potassium persulphate: (potassium sulphate peroxide), $\text{K}_2\text{S}_2\text{O}_8$, molecular weight 270. White, crystalline salt, 98–99%; contains 5.7–5.9% active oxygen, water soluble. Bleaching and oxidizing agent for greases, oils, silk, wool, dyes; starch degradient (desizing); for mordanting, browning, cleaning.

Potassium bi-tartrate: Cream of tartar, potassium acid tartrate, potassium hydrogen tartrate, $\text{KHC}_4\text{H}_4\text{O}_6$. Potassium bi-tartrate is often used with other chemicals as mordant for natural dyes.

Potassium dichromate: Also called potassium bichromate; $\text{K}_2\text{Cr}_2\text{O}_7$. Potassium dichromate is the most commonly used chromium ('chrome') mordant in wool dyeing, both with synthetic and natural dyes. In terms of health risks of repeated exposure, it is one of the most hazardous chemicals used by textile art dyers. It is corrosive to tissues and can cause ulceration. It is known to be a human carcinogen. It poses serious disposal problems.

Potassium mono persulphate: A "peroxygen" compound Potassium monopersulfate can be used as an alternative to hydrogen peroxide for bleaching. It is quite expensive, but a reasonably stable and safe-to-handle dry chemical. Some "non-chlorine shock" chemicals for swimming pools are based on this compound.

Potassium persulphate: (potassium sulphate peroxide), $\text{K}_2\text{S}_2\text{O}_8$, molecular weight 270. White, crystalline salt, 98–99%; contains 5.7–5.9% active

oxygen, water soluble. Bleaching and oxidizing agent for greases, oils, silk, wool, dyes; starch degradant (desizing); for mordanting, browning, cleaning.

Potassium thiocyanate: (potassium rhodanide), KCNS, molecular weight 97; density 1.9. Colourless crystals, transparent, deliquescent, hygroscopic, water soluble (in cold solution), also soluble in alcohol. Application: for increasing the dye affinity of wool, analytic (iron indicator = blood red dye).

Potato starch: Powder, pure white; Handle crunchy, floury, cool; usually pure; water content 19–21%. Properties: insoluble in water. If heated from slurry at 46.25°C swelling takes place, at 58.75°C gelatinization begins, at 62.5°C gelatinization ends. Paste: jellylike, slimy, sticky, slightly grey translucent, not very stable, has the lowest stiffening and adhesive power of all starches. Gradual liquefaction if continuously boiled. Boiling with oxidation product (e.g. sodium perborate) leads to (water) soluble starch; degradation by enzymes. Acids lead to dextrose. Alkalis (depending upon concentration) increase the viscosity at normal temperature (great adhesive power), boiling gives rise to very tough, creamy solution (without particular adhesive power). Similar also tannin, salts, paraffin, oils, etc. Finishing handle: mild, soft, supple, full. See **Starch**.

Potting fastness: Resistance to the effect of boiling water (wet decatizing). Guideline applies for wool and possibly in mixture with other fibres. Roll test piece around a glass rod, treat for 1 h in boiling distilled water with backflow. Dry in air at $\leq 60^\circ\text{C}$. Evaluation: change of shade, bleeding of white adjacent fabric (wool or cotton) with grey scale.

Potten Kant: (Characteristic pattern of the Antwerp lace (see), consisting of a pot or vase and conventionalized flowers. Originally the pattern pictured the Annunciation.

Poulaine: Shoes with extended (piked) toes.

Poulangy: Coarse and stout French twilled suiting, made in solid colours with linen warp and woollen filling.

Poult: A fabric similar to taffeta but usually heavier and with a more pronounced rib. The fibres used are acetate, triacetate, polyester or mixtures or even silk. It is made in plain colours. It is a stiff fabric liable to crease. Used only for formal dresses, coats, wedding gowns millinery.

Poult de la Reine: Very heavy silk dress goods, woven with a pebbled surface.

Poult de Soie: Solid coloured silk fabric, made in plain weave with a two-ply warp and a heavier filling containing more than two strands and forming cross ribs; used for dresses.

Pounce: To raise the nap on a felt hat with emery paper.

Pouritache: Similar to the soutache braid only much heavier.

Poussin: Very light, narrow French lace, similar to Valenciennes.

Powder cleaner: A cleaning agent in which an absorbent compound is the principal ingredient.

Powder cleaning: See more preferred term, **Dry extraction cleaning**.

Powder-bonded Nonwoven: A manufactured product in which a carded web is produced and treated with a thermoplastic powder that has a melting point less than that of the fibre in the web. The powder is heated to its melting point by through-air and infrared heating or by hot-calendering to effect bonding.

Powder-dot Coating: A method of powder coating whereby the melted powder is made to fall on the heated surface of the material to be coated and pressed so that the powder melts and adheres to the fabric in the form of droplets. Usually, in a dot powder coating machine the indentations of a heated engraved roller are filled with thermoplastic powder which is then

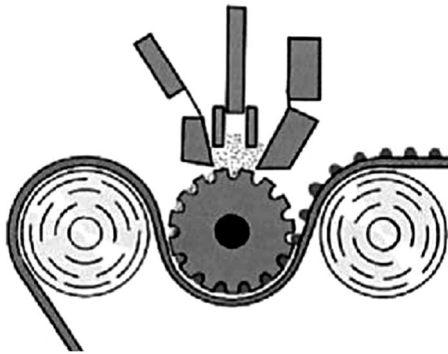

Dot coating sintering

slightly agglomerated. The material is heated to above the melting point of the coating powder on a heated roller. The hot fabric is pressed against the powder filled hollows, so that the melted powder is deposited on the surface of the material in the form of droplets. Subsequently in a further sintering zone the droplets are melted to form hemispherical pearls, which sit cleanly upon the surface of the fabric.

Powdering: Dotted pattern strewn all over the fabric.

Power: As physical variable: Work done per unit time, SI unit is Watt (W) = J/s.

Power bonding: A method of making thermally bonded non-woven fabrics in which a fibre web or batt is bonded by the use of heat sensitive powder dispersed within it.

Power factor: Of an insulating material, the ratio of the power in watts dissipated in a capacitor in which the material is dielectric, to the product of the sinusoidal voltage and current expressed in effective volt-amperes.

Power loom: A loom which is driven by a source of power such as an electric motor. If it is non-automatic, the shuttle change is done manually.

POY: See **Partially Oriented Yarn**. Polyester fibres.

PP: See **Polypropylene fibres**.

Ppb: (parts per billion), billionths = 10^{-9} .

Ppi, Finished: Picks Per Inch, Finished fabric.

PPI, In grey: Picks Per Inch, grey fabric.

PPI, In loom: Picks Per Inch, loomstate fabric.

Ppm: (parts per million), millionth = 10^{-6} .

Ppt: Parts per trillion.

PR : Protein fibres.

P.R.: (Pressley-Ratio) Pressley-Index.

Prato wool: Italian cloth export from Prato, previously made primarily of → Reclaimed wool, which after the Second World War achieved world-wide importance due to its low price (around 50% of production for export was for the Orient, West Germany, England, etc.).

Prayer Rugs/Prayer mats: Oriental rug of usually small size; used by tie Moslems to kneel on when praying. The chief characteristic is the representation of a niche' o-r arched doorway at one end, sometimes with the tree of life or a lamp hanging from the middle; occasionally there are only three medallions, two for the knees and one for the head.

Precieuse: Plain woven striped silk dress goods.

Precipitate: In chemistry, a solid formed by a reaction in a solution or as a result of physical changes, such a temperature, of the solution A precipitate has low solubility in the solution from which it was formed, giving a cloudy appearance, or actually settling out of solution.

Precision winding: A method of winding cones and cheeses in which the number of winds per double traverse is constant and angle of wind increases as the diameter increases. It can be used to build a very dense package.

Precision-wound packages: A winding method where throughout the winding process of a cone a regular winding is made at all diameters. The rewinding tube is positively driven and has an adjustable, constant ratio to the

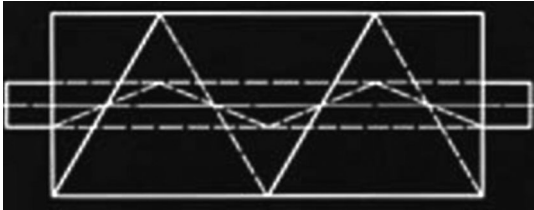

movement of the thread guide at all times. The thread distance can also be selected. The number of windings per winding stroke remains constant from the starting diameter to the full batch diameter. The most advantageous winding can be adapted at will to the yarn material and field of application. See **Crosswound yarn package**.

Pre-coating of screen: In order to facilitate possible painting of screens by hand, the screen is pre-coated e.g. with an auxiliary layer of gelatine or sodium alginate.

Precondition: To bring a sample or specimen of textile material to a relatively low moisture content (Approximate equilibrium in an atmosphere between 5 – 25 % relative humidity) prior to conditioning in a controlled atmosphere for testing.

Preconditioning: Bringing a sample or specimen of textile material to a relatively low moisture content (approximate equilibrium in an atmosphere between 5 and 25% relative humidity) prior to conditioning in a controlled atmosphere of higher humidity for testing. (While preconditioning is frequently translated as predrying, specimens should not be brought to the overdry state.)

Pre-cure: A process where the curing is done at the finishing plant in the flat state. A finishing treatment in which the durable press finish is applied to the fabric and set, or cured, through the use of heat at the mill, prior to shipment of the fabric to the garment manufacturer.

Pre-dip: Pretreatment of yarn or fabric with an auxiliary that promotes the adhesion of the subsequent impregnation.

Predrier: A drying unit for partially drying a wet fabric (usually padded) which should prevent migration in the main dryer due to the mild nature of drying. There are many methods of predrying where the IR drier is considered the best.

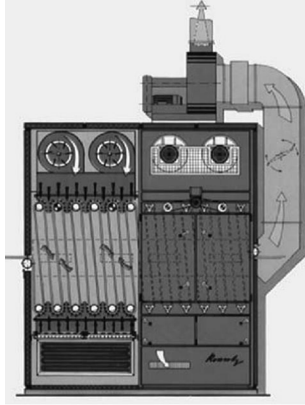

A nozzle pre dier

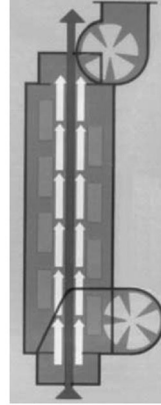

An IR predrier

Prefelting machine: Prefelting of folded fur hats by means of rotating rollers or rollers with strong rope wound around them (ropemill).

Preferential orientation: Preferential orientation of silicones on hydrophilic fibre surface to their water repellent finishing. The hydrophilic part of the silicon polymers align themselves to the fibre surface, whereas the hydrophobic parts point outwards.

Pre-lacquering: Positive process for screen making.

Pre-wound Bobbins: Refers to bobbins that are wound by the thread supplier. From 15 to 20% more thread can be wound by precision winding equipment than by a sewing operator using a sewing machine bobbin winder.

Preform: (1) Fabrics that have been stacked in multiple layers and bonded with a stitching yarn or by other means. The preform may be cut into a shape for subsequent molding into a composite part. (2) A preshaped nonwoven made by distributing fibres over a screen in the approximate contour of the finished part. (3) A preshaped, three-dimensional reinforcement made via braiding, weaving, or knitting or some combination of these. (4) A formed but not fully consolidated stack of prepared layers which have the contour of the finished product. (5) The first stage in the production of blow-molded products such as PET bottles.

Prein: A German process by which the shearing of the goods is eliminated by pressing all irregular fibres into the body of the cloth while it is in the loom.

Prelate: French sailcloth and tent canvas, made of hemp and coated with tar.

Preliminary treatment: Any treatment of wastewater that precedes *primary sedimentation*.

It is partly aimed at protecting equipment in later treatment. Mainly it is the removal of large solids, rags and grit by *screens, comminutors, grit channels*, etc. Oil, fat, grease, etc., may be removed in *pre-aeration*. For wastewater treatment works fed by *combined sewers*, preliminary treatment includes the proportioning of storm sewage—i.e. *storm water overflows*.

Pre-metallised dye: A dye that is a complex of dye molecules with a metal atom; metal complex dye The term “pre-metallized” is used primarily to refer to classes of acid dyes, although sometimes considered as apart from acid dyes. The metal is part of the dye structure as it comes from the manufacturer. There are 1:1 metallized dyes, having one dye molecule per metal atom, and 2:1 types, with two dye molecules per metal atom (use is inconsistent here 2:1 and 1:2 mean the same thing). The metal in the complex helps the dye attach to the fibre, typically wool or polyamide. These dyes have excellent wash fastness, but leveling may be difficult. There is a wide range of “pure” colours (as opposed to mixtures) available, though the brightness is the lowest of the acid dye subgroups. Application temperature is typically at or near the boil. 1:1 types are usually applied at very low pH, often with formic or sulphuric acid in quite large quantities, while 2:1, sometimes called “neutral dyeing”, are often applied using acid donor chemicals, so the bath is nearly neutral at the start and becomes more acid with continued boiling.

Premium: Commercial variety of early maturing upland cotton, the staple measuring 23-27 millimeters; the yield is 32-33 per cent; also called Peerless.

Pre-mordanting: Chroming.

Pre-sedimentation tanks: In water treatment, a term used for (a) *grit chambers* or (b) sedimentation processes used to remove large quantities or suspended material prior to the normal water treatment processes.

Preoxidized fibre: In carbon fibre production, a fibre that results from a relatively low temperature (200-500°C) heat treatment in the presence of oxygen which converts the precursor fibre, PAN or rayon, to an infusible fibre that is stable to further processing.

Preparation% (1) (formulation). Mixtures and solutions made of two or more substances.

(2) The process of making the grey fabric ready for dyeing, printing, finishing or for any other further process. The process generally includes desizing (in case of sized gerige) scouring, bleaching, mercerizing etc. for cotton and suitable process for other materials.

Preparation vessel: In textile finishing machines the treatment liquor is often prepared in a separate container, which is then supplied to the machine by a pump.

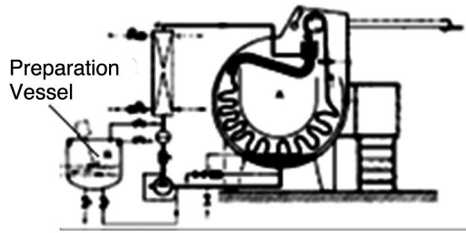

Example of a preparation vessel in jet dyeing

Prepared for dyeing: A fabric or garment that is specially made to be dyed; sometimes “preferred for dyeing”; usually abbreviated PFD, pfd or p.f.d. PFD fabrics have been desized, scoured, and fully bleached, but have been processed without optical brighteners or softeners which can interfere with dye uptake. Often called ‘prepared for garment dyeing’ or PFGD, such fabrics are usually only carried by specialty suppliers. Most fabric is prepared for dyeing at the same facility that does dyeing. Any fabric can be prepared for dyeing and sold as such, but types other than cotton are extremely rare, and often available only by special order of large quantities. PFD cotton garments are made with PFD fabrics and sewn with cotton thread, so that the thread will dye similarly to the fabric. Sometimes they are made oversize to allow for shrinkage in dyeing processes. A few large manufactures of t-shirts offer PFD shirts. It may be advisable to wash PFD products before dyeing, mostly as a hedge against contaminants picked up in handling or to remove thread lubrication oils that might have been used in garment construction.

Prepared for printing: A fabric that has been processed to be ready for printing, usually meaning printing with dye PFP cotton will be very similar to PFD cotton, but is almost always mercerized to improve the colour uptake. Wool fabrics are usually chlorinated in preparation for printing.

Prepigmentation: Unvatted vat dyes are padded onto fabric as a dispersion and deposit themselves onto the fibres as pigments during drying. Subsequent

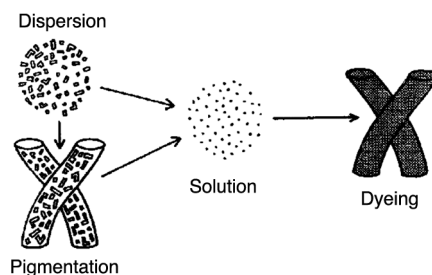

Principle of prepigmentation and dyeing

padding of chemicals (reducing agents and alkali) vats the dye to a solution, which diffuses into the fibre in the subsequent steaming process.

Prepreg: Ready-to-mold, reinforcing material, either fibre, fabric, or mat, that is fully impregnated with resin and in some cases, partially cured. Prepregs are



The processing of a prepreg in a deep drawing process.

then used by fabricators in laying-up and molding composites after which curing is completed. Prepregs are not free-flowing, and therefore cannot change shape independently. Prepregs consist of thermoplastic fibres (PA 6.6) or non-meltable fibres (in the field of prepreg forming), such as glass fibres, carbon fibres or para-aramide fibres; this selection is based upon the profile of requirements of the fibre-reinforced plastic component to be produced. The shaping processes that come into consideration are similar to the deep drawing process common in sheet processing.

Pre-printed resist: Half-tone resists; Resist printing.

Preservative: Used to protect textiles and finishing substances (sizes, printing thickeners) against decomposition due to micro-organisms. Common preservatives in textile finishing are fungicides and bacterial poisons, often typical disinfectants, which should be used with care.

Preservatives, in sizing: To prevent the growth of bacteria and fungi in size mixes and on sized yarn. Cresol, phenol, salicylic acid are examples of preservatives.

Presetter: Used for the presetting of unsewn hosiery blanks, for fixing hosiery or socks made of polyamide (Hosiery setting) and for the relaxing of tufted carpets (Carpet pre-steamer). Working method for hosiery in saturated steam process with or without vacuum plant.

Presetting: Heat setting at temperatures that lie below the softening range of synthetic fibres, so that they are protected against creasing and folding in subsequent finishing operations, specifically wet processes.

Preshrink: Steam or hot water pre-treatment for textured yarn for the development of texture.

President: A double woollen fabric, the face made with cotton warp and woollen filling in five-leaf satin weave, the back with an extra mohair filling in two and one weave.

President: Braid A twilled woven braid with diagonal ribs; used for trimming.

Presidents: In Europe napped woollen fabrics, made with a large proportion of shoddy or mungo.

Pre-Shrunk: Quality term for material that has been relaxed to the degree that under the effect of a normal ironing the length and width of the sample decrease by no more than $\pm 1\%$ (See **Shrinkage**; **Sanforize**). Such a material may still have a press lustre, for example, (final treatment on the flat press) which is not itself fast to hot pressing or spotting.

Press: A finishing process, consisting in pressing the fabric between heated plates or cylinders.

Press-Off, in knitted fabric: A condition in which the yarn fails to knit and either the fabric falls off the needles or the design is distorted or incomplete.

Pressboard: Special cardboard, which is used as glazed millboard in Flat press and is placed between the layers of material.

Pressed-increase: A sharp crease inserted intentionally in a fabric usually by application of pressure, heat, moisture or a combination of two or three.

Presser foot: An attachment which presses the material being sewn against the lower feed during sewing.

Pressing: See also **Ironing**. Removing or creating of creases or shape in material by heat and/or steam and/or vacuum or a combination of them with pressure.

Pressing marks: The accidental occurrence of “stripy”, curved or wavy folds or pleats as a result of unskilled ironing.

Pressing (Finishing): A method of enhancing the appearance of fabric, by application of pressure to increase their lusture and smoothness. *Note:* The equipment used varies with the type of fabric being finished. For e.g. (a) a hydraulic press in which the layers of cloth formed by cutting the material are interleaved with heated or cold press papers and the pile of cloth so formed is subjected to pressure. (b) a rotary press in which fabric is formed by by a smooth rotating heated cylinder and a fixed curved metal plate, pressure between the two elements being applied hydraulically. (c) garments and knitted goods are pressed by being placed on a perforated, fabric covered steam bed and subjected to pressure by lowering a second hinged steam bed on to the material. Steam is blown through the material while under pressure and the fabric can be cooled by drawing air through it. This type of machines is often known as a hoffman press and is the process as Hoffman pressing. Many new machines and methods are introduced from time to time.

Pressing and curing: A variety of industrial pressing and curing treatments used in garment industry.

Pressing off: The final pressing operations on a garment after assembly (or Off pressing).

Pressley Index, in cotton testing: A measure of the strength of fibre bundles determined under prescribed conditions and expressed in an arbitrary units pounds per milligram.

Pressure: Force or load per unit area. Mechanical tension. The derived SI unit is the Pascal (unit symbol: Pa).

$$1 \text{ Pa} = 1 \text{ N/m}^2 = 10^{-4} \text{ N/cm}^2 ; 1 \text{ N/cm}^2 = 10 \text{ kPa}$$

Special name for the tenth part of the mega pascal

(MPa) is the Bar (unit symbol: bar):

$$1 \text{ bar} = 0.1 \text{ Mpa} = 100 \text{ kPa} = 102 \text{ kPa} = 105 \text{ Pa}$$

$$1 \text{ bar} = 1000 \text{ mbar}$$

The previously used Torr, at., and kp/cm^2 units are no longer permitted:

$$1 \text{ mbar} = 0.750 062 \text{ Torr}$$

$$1 \text{ bar} = 1.01971621 \text{ kp/cm}^2$$

Pressure drier: In this drier the system is completely closed and pressurised, up to 8 bar. The moisture is extracted from the circulating air via a cooler, heated up and fed back into the boiler; the water is removed by a separator. See **Yarn dryer, air stream**.

Pressure drop: (1) A decrease in pressure that is caused by friction between a flowing liquid and a constricting container. The pressure drop is increased by a reduction in diameter of the container. (2) The change in pressure across a filter.

Pressure dyeing: See **Dyeing**.

Pressure filter: (1) A *filter plate press*. (2) A rapid *sand filter* that is not open to the weather but is contained in a steel shell. It can therefore work at a pressure higher than the gravity head and may be an *in-line* treatment. The sand is 0.45 to 1 m deep, with an *effective size* between 0.5 and 1 mm and a maximum *uniformity coefficient* of 1.7. *Surface loading rates* are from 4 to 10 m^3/h per m^2 of filter area, although up to 20 m^3/h per m^2 has been used. Compare *rapid gravity filter*.

Pressure kier: Wrought iron autoclaves for the kier boiling of loose stock, yarn, wound packages and piece material.

Pressure mark: See **Bruise**.

Pressure mark: An impression or an area of greater lustre in fabric, caused by irregularities of pressure during the finishing process.

Pressure relief valve: A spring loaded pressure relief valve is designed to open to receive excess pressure and to reclose and prevent further flow of fluid after normal conditions are restored. It is characterized by a rapid opening 'pop' action or by opening in a manner generally proportional to the increase in pressure over the opening pressure. It may be used for both compressible or non-compressible fluids, depending on the design, adjustment, or application.

Pressure steamer: Continuous steamer for steaming at temperatures above 100°C for developing pad dyeings and prints or HT bleaches. Discontinuous for combed tops (vigoureux) printing, loose material and piece goods. See **HT pressure steamer**.

Pressure steaming process: Fixing, for example, of disperse dyes in the pressure steamer at 130°C with saturated steam. Application on polyester combed tops and spun tow. See **Thermosol dyeing processes**.

Pressure Vessels: All vessels or pipe layouts in which, when in use, there is a positive operating pressure greater than 0.1 bar or a negative operating pressure of under 0.2 bar.

Pretension: The relatively low tension applied to remove the kinks and crimp when mounting a specimen preparatory to making a test and used to establish the nominal gauge length.

Pretreat, in cleaning of textiles: Pre-application of cleaning agent to spots, stains and areas of high soil concentration to maximize activation time and therefore facilitate soil removal during overall cleaning.

Pretreatment: Treatment of a fabric for the next operation like dyeing printing etc.

Pretreatment Jig: Jigger used for the pretreatment of fabric.

Pretreatment, in ETP: (1) For industrial wastewater, partial **on-site treatment**. (2) In wastewater treatment, **preliminary treatment**. (3) For sludge treatment, **conditioning** to improve its **de-waterability**.

Price points: Price at which products will retail.

Primary backing, for tufted pile yarn floor covering: The fabric through which the pile yarn is carried by needles to form tufts; the backing fabric.

Primary cellulose acetate fibre: See **Triacetate fibre**.

Primary colours: Magenta, yellow, and cyan (red, yellow, blue); these are the subtractive primaries used when mixing dyes, paints, etc., to make all other colours. In the CIE (Commission Internationale de l'Eclairage) system

of colour measurement, which is the international system most widely used today, the primary colour vectors are red, green, and blue-violet. These are additive primaries based on the perception of colour of reflected light by the human eye.

Primary colours: The visual organ can achieve eight extreme sensory options. In a mixing system (Colour mixtures) for opaque colorants all eight colours are needed: cyan, black, green, violet blue, magenta red, white, orange red and yellow.

Primary creep: The recoverable component of creep. Also see **Delayed deformation**.

Primary salts: Acid salts of multivalent acids, in which only one hydrogen atom is replaced by metal; e.g. primary acid sodium phosphate NaH_2PO_4 derived from phosphoric acid H_3PO_4 . Secondary salts; Tertiary salts.

Primary sedimentation: The *sedimentation* in wastewater treatment that immediately follows grit removal, releases settled wastewater for biological treatment and removes organic solids as sludge. **Radial flow sedimentation tanks** or **horizontal flow sedimentation tanks** may be used. The design is often based on the *surface loading rate*, which should be about 30 to 45 m³m⁻²d⁻¹ at maximum flow to ensure 50 to 70% removal of suspended solids and about 30% removal of BOD from domestic wastewater.

Alternatively, the design retention time is 1.5 to 2 h at maximum flow, usually 3 times *dry weather flow*. **Weir loadings** should be less than 250 m³m⁻¹ day⁻¹, although this is less critical than the overflow rate. See **primary sludge**, **sludge hopper**.

Primary treatment: For wastewater treatment, the first major treatment process, which is usually *primary sedimentation*.

Prime: Merino clothing wool taken from sides of a very fine fleece or shoulder of a good fleece.

Princes lace: An imitation of luxurious Duchesse Lace.

Princesse: Four-leaf silk satin dress goods, made with single warp.

Princesse Cashmere: French cotton dress fabric, made in imitation of cashmere.

Princetta: An English worsted fabric in the 19th century, made with silk warp and worsted filling; originally made of pure worsted.

Print: A fabric with designs applied by means of dyes or pigments used on engraved rollers, blocks, or screens.

Print bonding: A process of making nonwoven fabrics in which there is

controlled application of adhesive to specific areas of the fibre web or batt in a discrete pattern by using printing techniques similar to those used for colouration.

Print coverage: In textile printing the ratio of dye applied/printing area.

Print definition: The so-called staying power of a print paste, i.e. the upper limit of possible thickener concentration for printing purposes (Flow properties of thickeners and print pastes) at which the print paste covers the fabric uniformly (not to be confused with full print penetration). At an even higher concentration, the print would already “grin”.

Print-Dye process: 2-stage process consisting of printing/drying and dyeing/rinsing for floor coverings.

Print flushing: Print flushing arises due to excessively deep engraving, inadequate absorbency of the printed material and excessive pressure by the printing roller on the material, either on one side or on both sides. Print flushings show up on the material as blurred, lacerated contours, which usually run opposite to the printing direction.

Print impression method: This was developed for examining the surface of engraved calendar rollers and rotary screens for screen printing, and are based upon the creation of an imprint in polystyrene by means of a silicon rubber negative. The print impression method, originally developed for use with the scanning electron microscope, is now used with the stereomicroscope.

Print paste: The mixture of gum or thickener, dye, and appropriate chemicals used in printing fabrics. Viscosity varies according to the types of printing equipment, the type of cloth, the degree of penetration desired, etc.

Print paste sieving machine: (sieving machine), is used for the: Straining of print pastes; Printing thickeners and chemical finishing products. The method of operation can vary greatly; e.g. brush principle (with 1, 2 or 4 sieving points), pulsation principle, vacuum principle for sucking through the gauze at high sieving speed (vacuum filtering or screening machine), in which blocked screen sections cannot be ruled out however, and the colour grinding mill principle for particularly fine milling. For the purpose of screen printing, when print paste containers with replaceable silk cloth screens are used, the gauze one number finer than the screen gauze is always selected.

Print paste straining centrifuge: The print pastes run into the centrifuge via a funnel. The inner screen mesh basket rotates and sieves the print pastes. In centrifuging, special inserts are used to separate the impurities from the print pastes by centrifugal force.

Print paste wedge: In screen printing, wedge shaped area formed by the angle

between blade/rod squeegee and flat/rotary screen. The print paste wedge is a determining factor for print paste application. If the blade squeegee is set at a shallow angle then a long, narrow wedge forms (print paste application is correspondingly lower); alternatively in rod squeegees of different diameters. The wedge is shorter in blade squeegees set at a steep angle. The wedge pressure created is decisive.

Print steamers: After the application of the dye paste and the drying of the printed textile the material passes through the print steamer to transfer the dye from the thickener into the fibre. To achieve this the dried material is collected and passed onto a separate process, e.g. a high performance universal loop steamer with 2 adjacent tracks. If possible the moisture content of the steamer should be constant.

Printcloth: A medium weight, plain-weave fabric made of carded yarns, usually cotton or polyester/cotton blends, with counts from 28's to 42's. Millions of yards of print cloth are printed annually and other millions are finished as white goods. Large amounts of the goods are also used in the greige for bags, containers, and base fabric for coated materials.

Print-dye process: A print technique followed in textile floor coverings. It is 2-stage process consisting of printing/drying and dyeing/rinsing finishing for floor coverings. Chemicals, resist,(half or full tone resist) agents are applied to the material in a colourless print paste using a suitable printing machine. On dyeing the printed portion remains undyed or partially dyed as per the resist agent.

Printed suede: Silk screen printed suede fabric produced as piece goods for high quality women's wear and men's wear.

Printing: The reproduction of a pattern onto a textile material by applying a suitable substance by means of an engraved surface, a stencil or other patterning device.

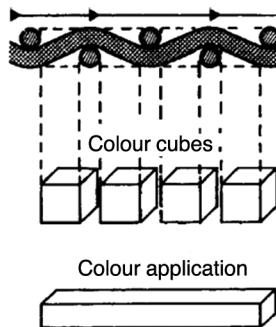

Schematic representation of the printing process.

Printing: A process for producing a pattern on yarns, warp, fabric, or carpet by any of a large number of printing methods. The colour or other treating material, usually in the form of a paste, is deposited onto the fabric which is then usually treated with steam, heat, or chemicals for fixation. Various types of printing are described below: Also see **Dyeing**.

(1) Methods of Producing Printed Fabrics:

Block Printing: The printing of fabric by hand, using carved wooden or linoleum blocks, as distinguished from printing by screens or roller.

Blotch Printing: A process wherein the background colour of a design is printed rather than dyed.

Burn-Out Printing: A method of printing to obtain a raised design on a sheer ground. The design is applied with a special chemical onto a fabric woven of pairs of threads of different fibres. One of the fibres is then destroyed locally by chemical action. Burn-out printing is often used on velvet. The product of this operation is known as a burnt-out print.

Direct Printing: A process wherein the colours for the desired designs are applied directly to the white or dyed cloth, as distinguished from discharge printing and resist printing.

Discharge Printing: In “white” discharge printing, the fabric is piece dyed, then printed with a paste containing a chemical that reduces the dye and hence removes the colour where the white designs are desired. In “coloured” discharge printing, a colour is added to the discharge paste in order to replace the discharged colour with another shade.

Duplex Printing: A method of printing a pattern on the face and the back of a fabric with equal clarity.

Etching: See **Printing, Burn-Out Printing**.

Extract Printing: See **Discharge Printing**.

Heat Transfer Printing: A method of printing fabric of polyester or other thermoplastic fibres with disperse dyes. The design is transferred from pre-printed paper onto the fabric by contact heat which causes the dye to sublime. Having no affinity for paper, the dyes are taken up by the fabric. The method is capable of producing well-defined, clear prints.

Ink-Jet Printing: Non-contact printing that uses electrostatic acceleration and deflection of ink particles released by small nozzles to form the pattern.

Photographic Printing: A method of printing from photoengraved rollers. The resultant design looks like a photograph. The designs may also be photographed on a silk screen which is used in screen printing.

Pigment Printing: Printing by the use of pigments instead of dyes. The pigments do not penetrate the fibre but are affixed to the surface of the fabric

by means of synthetic resins which are cured after application to make them insoluble. The pigments are insoluble, and application is in the form of water-in-oil or oil-in-water emulsions of pigment pastes and resins. The colours produced are bright and generally fast except to crocking.

Resist Printing: A printing method in which the design can be produced: (i) by applying a resist agent in the desired design, then dyeing the fabric, in which case, the design remains white although the rest of the fabric is dyed; or (ii) by including a resist agent and a dye in the paste which is applied for the design, in which case, the colour of the design is not affected by subsequent dyeing of the fabric background.

Roller Printing: The application of designs to fabric, using a machine containing a series of engraved metal rollers positioned around a large padded cylinder. Print paste is fed to the rollers and a doctor blade scrapes the paste from the unengraved portion of the roller. Each roller supplies one colour to the finished design, and as the fabric passes between the roller and the padded cylinder, each colour in the design is applied. Most machines are equipped with eight rollers, although some have sixteen rollers.

Rotary Screen Printing: A combination of roller and screen printing in which a perforated cylindrical screen is used to apply colour. Colour is forced from the interior of the screen onto the cloth.

Screen Printing: A method of printing similar to using a stencil. The areas of the screen through which the colouring matter is not to pass are filled with a waterproof material. The printing paste which contains the dye is then forced through the untreated portions of the screen onto the fabric below.

Warp Printing: The printing of a design on the sheet of warp yarns before weaving. The filling is either white or a neutral colour, and a grayed effect is produced in the areas of the design.

(2) Methods of Producing Printed Carpets:

Millitron Process: A computer-controlled, non-contact spray printing process that allows the production of intricate multi-coloured designs. Although this process was developed for carpets by Milliken & Co., it can also be used for upholstery, pile fabrics, and other textiles.

Mitter Printing Machine: A rotary carpet printing machine with up to eight stainless-steel mesh screens, and with cylindrical squeegees of moderately large diameter in each rotary screen. The unit has a streaming zone for dye fixation.

Stalwart Printing Machine: A carpet printing machine in which colour is applied to the carpet with a neoprene sponge laminated to the pattern. The pattern is cut in a rubber base attached to a wooden roll. It is very similar

to relief printing. Used primarily for overprinting random patterns on dyed carpets. Suitable for shags and plush carpets as well as level loop and needle tuft types. ***Zimmer Flatbed Printing Machine (Peter Zimmer)***: A carpet printing machine that uses flat screens and dual, metal-roll squeegees. The squeegees are operated by electromagnets to control the pressure applied. The unit also has a steamer for dye fixation. The Zimmer flatbed machine is normally used for carpets of low to medium pile heights.

Very precise designs are possible, but speeds are slower than with rotary screen printers.

Zimmer Rotary Printing Machine (Johannes Zimmer): A three-step, rotary carpet printing machine consisting of: (i) rotary screens with small diameter steel-roll squeegees inside, with pressure adjusted electromagnetically for initial dyestuff application; (ii) infrared heating units to fix dyes on the tips of the tufts; and (iii) application of low-viscosity print paste, followed by steaming for complete penetration of dyes into tufts. ***Zimmer Rotary Printing Machine (Peter Zimmer)***: A rotary carpet printing machine in which each rotary screen has a slotted squeegee inside to feed print pastes through the screens to the carpet. Pressure of the print paste is adjusted by hydrostatic head adjustments.

Printing area: That part of the gauze of a screen printing screen that is permeable to print paste.

Printing blanket: Endless rubber coated fabric, which in roller printing is pulled over the lapping on the main cylinder.

Printing carriage: A movable carriage in which the printing screens are mounted one at a time. The carriage is supported on wheels running along rails at either side of the printing table. The printing screen is raised or lowered by lever action, and the squeegee (used to force print paste through the screen) is driven across the screen by a motor attached to the carriage.

Printing carriages of this type represent a partial mechanization of the hand screen printing process.

Printing gauze: See **Screen mesh, screen gauze**.

Printing rollers With regard to the type of colour paste application a differentiation is made between printing with deep engraved rollers, roller printing and relief printing, in which the rollers have the pattern embossed upon them.

Printing screen locking unit: Printing tables are fitted with a U-shaped rail at the front, upon which repeat stops are mounted. The locking units fastened onto the screens fall into the repeat stops when the screen is lowered and thus hold the screen securely in the repeat.

Printing screens: See **Screens for screen printing.**

Printing style: Fundamental technical possibilities for printing fabrics: Direct printing; Discharge printing; Resist printing; Blotch printing.

Printing table: Support for the fabric to be printed in block screen printing and flat screen printing.

Printing thickener: Finished product of Thickeners for printing (Print pastes). Every composition is dependent upon fibre material, fabric type, print pattern, dye group, printing process, etc.

Printing unit: Finished product of Thickeners for printing (Print pastes). Every composition is dependent upon fibre material, fabric type, print pattern, dye group, printing process, etc.

Printing without screens, Digital printing: See **Digital printing.**

Printing, methods Of: See **Printing.**

Prints on dyed ground: Prints can be done on dyed ground, either as over print or as discharge printing. Over print will give a shade which is a total of print colour and dyed colour. Where printed as a discharge print on dischargeable ground the ground colour is completely discharged and a pure print colour will be seen. By this method the ground can be completely discharged to a white print also. In both cases the ground dyeing is done as per the demands of the print to be undertaken.

Priority pollutants: Organic and inorganic compounds selected on the basis of their known or suspected carcinogenicity, mutagenicity, teratogenicity or high acute toxicity. Many of these compound are found in waste water.

Probability: Statistical frequency of comparable events in Populations. The ambiguous term “probable” expresses the fact that there “appear” to be more arguments in favour of the prediction. The verification value is equal to zero in the individual case. We talk of mathematical probability because statistical probability evaluates the laws of large numbers (See **Stochastic.**)

Processing Performance: A general term denoting the processing efficiency of a specific process or covering a group or series of process.

Processing sequence: In the context of a work analysis this consists of individual processes: Operating time, Production resources, Handling time factor. The processing sequence is also divided into a sequence of individual processes.

Processing sequence in textile finishing: Sequence of the individual working steps; these are often determined by the experience of the finisher. If the aims of the finishing process are specified in a logical manner based upon the

profile of requirements for the finished material the processing sequence can be determined by factual arguments.

Processing time: (1) Part of the Handling time factor or basic time for all direct processing operations on the material. (2) Operating time, usable life, gel time, Working life; term for the period of time from applying a synthetic resin to when it is still just possible to process it, i.e. shortly before the onset of gelling. Important for condensation resins, because their viscosity falls sharply when the processing time is exceeded, whereupon they gel and then become unusable.

Procion: A trade name, originally belonging to Imperial Chemical Industries of Britain, now to Dystar of Germany, and used for their lines of reactive dyes, including the very popular MX family. Although it is often seen in art and hobby dyeing publications, the term ‘Procion dye’ is incorrect because it omits the name of the specific family such as MX (usually what is meant) or H or H-E. Dystar apparently no longer manufactures Procion MX, but others, not entitled to use the Procion name, do manufacture “MX” type dyes.

Producer twist: Small amounts of twist, usually $\frac{1}{2}$ turn per inch or less, applied to yarns by the manufacturer to provide cohesion of filaments for further processing.

Producers risk: The probability of rejecting a lot when the process average is at the acceptable quality level (AQL).

Producer-textured yarns: Continuous filament yarns that have been bulked during manufacturing by the fibre producer. (Also see **Texturing**.)

Product based, in testing: In this definition quality is viewed as a quantifiable attribute based on the product’s performance in fields such as durability or reliability. Because it is quantifiable then quality can be determined objectively.

Product development: is carried out by the textile designer (known as the designer in the cloth industry). After a creative phase, product development moves into the realisation phase; the pattern collection is developed.

Production: Manufacture, generation of products from raw materials or semi-finished goods, e.g. by textile finishing. In a broader sense, factors of production as commercial service provision: purchasing, transport, stocks, manufacture, administration, checking; without financing and sales.

Production control: (1) The logging of process data and its processing and provision to the sender for decision making and influencing the process as part of manufacturing control.

The automation devices used for production control consist of a central processing unit and a certain number of decentralized recording devices

for manual entry or semiautomatic or automatic recording of data directly at work places, whereby the central processing unit incorporates at least a minicomputer. (2) Quality control.

Professionalism: Demonstrated by self-confidence and flair, capability and expertise, rational and systematic thought, creativity and judgement, sensitivity to environment, and to other professions, nationalities and cultures, appreciation of business in global context, and a lifetime commitment to personal education and professional advancement.

Profile reed: A reed the front of which is shaped to form a channel. The reed serves to separate the warp threads, to determine their spacing to guide the weft across the loom in air jet weaving, and also to beat up the weft.

Profiled fibres: This group, which includes hollow profiled fibres, consists of modified cross-section synthetic fibres, produced by spinning the melt from profiled jet orifices usually with a slit-shaped or pointed profile: Star-shaped, trilobal to multilobal, i.e. 3, 5, 6, 10 cornered/pointed, etc. (other cross-sectional variations, such as normal hollow fibre types, the straw type, flat shapes, large letter shapes, etc. are only associated in the broader sense).

Profiled hollow fibres: Hollow fibres based upon polyamide and polyester with additional cross-section profiling. Additional advantages compared to round cross-sections and also compact profile figures: further increased voluminosity (up to approx. 40%), greater stiffness, improved heat retention capacity (up to approx. 20%), reduced transparency of knit goods (up to 50%), double the durability for hosiery.

Profit: The monetary gain from being in business; the excess of revenues over outlays and expenses in a business enterprise.

Prograde mercerizing process: Process patented by Coats under German Patent for the mercerizing of sewing yarn on running threads (150–200 m/min). The yarn runs through liquid ammonia at -33°C for max. 10 s and the ammonia then removed by heat and steam, whilst the yarn is drawn. Ammonia consumption approx. 20–50% of material weight. The structural change of the cotton is similar to Mercerizing with caustic soda liquor. A marked increase in breaking strength and dye take-up is achieved. The lustre, on the other hand, remains the same.

Progressive: (Lat.: progressus = progress), increasing, continuing in stages; e.g. progressive feed of textiles, sequential wet/dry cycles, or progressing onwards from wash to wash, i.e. increasing shrinkage each time (in wool also as felting shrinkage).

Projectile: In projectile weaving machine the weft insertion is carried out by small clamp, called projectile. There are various projectile versions: made of

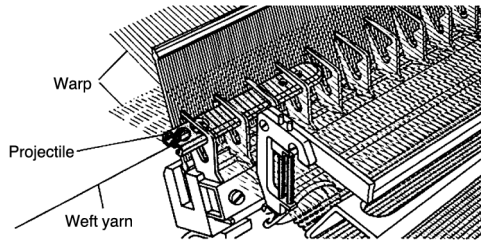

Weft insertion by projectile

steel, 9 cm long and 40 g heavy, with small section, as suitable for yarns of fine to medium count; made of steel, 9 cm long and 60 g heavy, with large cross-section which, thanks to their higher weight and to the larger clamping section of the gripper, are particularly suited for machines with high reed width or when for weft bulky yarns, as e.g. fancy yarns, are used. See **Projectile loom**.

Projectile loom: A shuttle less loom that uses small, bullet-like projectiles to carry the filling yarn through the shed. Fill is inserted from the same side of the loom for each pick. A tucked selvage is formed. (Also see **Weft insertion**.) In this weaving machine the weft insertion is carried out by small clamp projectiles, which number depends on the weaving width and which with their grippers take out the weft yarn from big cross-wound bobbins and insert it into the shed always in the same direction. The projectiles work in sequence, that is they are launched in succession. They run therefore one after the other, describing in the space a continuous, endless route, as if they would be stuck on a conveyor belt.

The first projectile takes and holds in its back the weft in form of a tail; then, pushed by the release of the projectile thrower, it passes through the shed and deposits the weft inside the warp; subsequently the projectile falls and is collected by a device which, by passing under the array of the warp threads, takes it at reduced speed back to the starting point. Here the projectile goes up to take up a new weft; meanwhile the other projectiles have run after each other making the same operation.

Proof: Resistant to a specified agency either by reason of the physical structure or the chemical non-reactivity of the textile, or arising from a treatment designed to impart the desired characteristics.

Note: (a) Proofing treatments should be defined by specified limits ascertained by tests, and the use of the term should be related to the limiting conditions. (b) The indiscriminate use of this term is deprecated, and its substitution by words such as “resistant”, “retardant” or “repellent” in the appropriate context is recommended.

Proofed: Descriptive of material that has been treated to render it's resistant to a specified agency. Note: The efficacy of a proofing treatment is normally defined by a limit that is related to a specific test procedure, and the use of the term should be related to limiting conditions. The designation of materials as 'proofed' should indicate that the material conforms to definite standards.

Proofed gabardine: Crisp medium weight fabric, usually cotton or polyester, that is shower proof.

Proofed poplin: This is usually heavier weight than dress poplin but constructed in the same way. It may be polyester or cotton or polycotton. The fabric has been treated to make showerproof. Used for rain coats, anoraks.

Proteases: An enzyme used in the scouring and bleaching of Jute. It degrades the lignin and improves bleachability. Pectins, waxes, colour, residual seed coatings can be removed. These substances, inhibit the natural absorbency of the fibre and prevents dyeing, printing and other finishings. Earlier scouring was done by caustic soda to remove desirable natural lubricants and other materials, which causes heavy effluent disposal problem.

Protective clothing: Protective clothing is the one which gives protection against undesired harmful effects. It can be a particular hazard or a combined requirement of multiple hazards. The multiple hazards can be protected by a single cloth or different layers of cloths. Simplest example is fire protective clothing's.

Protective colloids: Particles in dispersion has a tendency to aggregate. Some Lyophilic Colloid, which has the property of delaying the aggregation of the particles of a hydrophobic dispersion within certain concentration ranges. This tendency permits the protective colloid to attach itself to emulsified or suspended particles (precipitated lime soap, dirt, dye, delustring pigments, paraffin, etc.), envelop them and, because they have the same (negative) charge, to mobilize mutually repellent forces, which act against coagulation and keep them in a finely dispersed suspension. Examples are gelatine, glue, albumin, starch (natural), Sulphite cellulose waste lye, oil sulphonate and fatty acid and protein condensation products and nonionogenic polyether alcohols (synthetic).

Protein: Biological polymers made up of amino acids All hair-based fibres (wool, mohair, etc.) are protein based. Silk is also a protein fibre. Acid dyes are the most common type used for protein fibres. Reactive dyes are used in some cases. Basic dyes can be used, but generally produce very poor fastness on protein fibres.

Protonation: Due to their small ionic radius and their charge, hydrogen ions are mobile if they are attracted to an opposing charge or by free electron pairs. This property of acids is due to the electrolytic dissociation of substances, and thus to the fact that substances in aqueous solution decompose into electrically charged ions. Ions migrate in the electric field and always transport the same gram-equivalent quantity of electricity, namely 96 494 Coulombs.

Protrusion in fabrics: A yarn or a part of a yarn pulled or plucked from the surface.

Prud'homme black: See **Aniline black**.

Prunella: A fine worsted cloth that has largely gone out of use. It was twill weave and light in weight, made in plain colours only. Often used for children's clothes, but also for clergymen's wear.

Prunelle Batarde: Plain French serge, made with 8 or 10 ends and four or five picks in a repeat.

Prussian Binding: In England, made with silk face and cotton back and is twilled diagonally; is used as binding on waterproofs and coats.

Prussian Shawls: Fringed, twilled cotton shawls printed twilled cotton shawls printed in Oriental designs in England.

Prussian Velvet: A German pile fabric, made with cotton or linen warp and mohair filling, which forms the pile.

Prussiate black: See **Aniline black**.

Prussiate discharges: Oxidation discharges, of the type for para red on indigo background. However, it only has an historical importance.

PS: (1) Pakistan standard.

(2) Horse power. See **Watt**.

(3) Polystyrene.

PSA: Philippine Standards Association,

PSI: Pakistani Standards Institute

PST: Polystyrene fibres.

Pseudo- (Gk.), not genuine, imitation, apparent. **Pseudo-hair:** A "fake hair", for example the beard of a whale with its elastic-fixed intermeshed, scaly radial structure, which is similar to hair, but differs in its structure and purpose (filtering out plankton as food).

Psychrometer: A variety of hygrometer comprising a dry bulb temperature indicator and a wet bulb temperature indicator which is cooled to the wet bulb temperature by the spontaneous evaporation of moisture.

p/tex: Pond pro tex, obsolete unit of force in relation to fineness. SI unit is cN/tex, (centinewton).

PTFE: Polytetrafluoroethylene fibres.

PTO fibres (Enkatherm): Enkatherm, a high temperature flame-proof fibre is based on poly (terephthaloyl oxalic-bis-amidrazone) (PTO). This fibre is produced by wet-spinning and then drawn.

PU: (1) Polyurethane, (2) Abbreviation for Liquor pick-up, quoted in %, related to the weight of the dry or wet textile entering the machine.

PUA: Polyurea fibres

Pua Hemp: Very strong bast fibre, resisting water; found in Assam, Burmah, Japan, etc., where it is used for fishing nets, ropes, twine, bags, etc.

Pucker: An undulation in the fabric, caused by wrong conditions during finishing, e.g. during compressive shrinking.

Pucker, in sewing, in garments: Generally unwanted material waviness along the line of stitching.

Puckering: Wavy, three dimensional effect typified by closely spaced wrinkles on either face of the fabric. Puckering may be due to (a) differential shrinkage of the component layers (in laminated and bonded fabric) or (b) difference in tension when the component layers are combined (c) selective lineal delamination.

Pudding Cloth: Plain woven bleached cotton fabric in England; used in cooking.

PUE: Polyurethane elastomer fibres (elastane).

Puke: A woollen fabric worn during the Middle Ages in England.

Pull: A group of fibres grasped by the forceps at one time and drawn from the specimen in the combs.

Pull-in: See **Jerk-in**.

Pull, in Zipper: A part connected to the zipper slider by which the slider is operated.

Pulled in filling: An extra thread dragged in the shed with the regular pick and extending only a part of the way across the cloth. See also **Dragged-in**, **Jerked-in**, **Lashed-in**, **Whipped-in**.

Pulled Wool: Removed from the skin of killed sheep through "painting" the fleshy part with lime.

Pulling Cotton: A test to determine the length, strength and uniformity of length of the fibres, in buying cotton for mills. A small quantity of cotton is

pulled apart with two hands, the projecting long fibres separated from the rest and broken between two hands to test the strength.

Pulp: The end product of cooking wood chips, cotton, or some source of cellulose with water and appropriate chemicals. Used in the manufacture of cellulosic fibres, paper, and other cellulose-based products.

Pultrusion: The production of continuous lengths of fibre-reinforced advanced composites.

Fibre are fed as roving, fabric, or mat, or some combination of these, through a resin impregnation process, to a forming guide, then to a heated die to produce a specific shape, and finally to a puller where the structure is pulled through different forming and cooling stages.

Thermoplastic fibres may be substituted for the resin in the pultrusion process

Punched Felt: Wool stock of short staple but good felting property is attached to both sides of a burlap by barbed needles. The wool is then felted. Also called needle felt.

Punjums: A very tough fabric made in Visakhapatanam, Andhrapradesh, India as work wear. Dyed blue at Chennai, India, the punjums found their way to markets in Brazil, the Mediterranean and the West Indies as dress material for the slaves.

Puni: A puni is a tighter-than-normal rolag traditionally used with cotton.

Punpee: Chinese unfinished taffeta. See **Pong'ee**.

Punta Arenas: Very good, spongy and bulky wool, grown in the Terra del Fuego; used for knit goods.

Punto: Spanish and Italian for mesh or lace.

Punto Aquila: A medieval Italian linen lace, made in the Abruzzi mountains. It was a bobbin lace, somewhat similar to the English point, showing designs with raised edges, both the design and the net ground, being made at the same time of fine, bleached, hand spun linen yarn.

Pupa: A Stage in the life cycle of Silk worm.

PUR: Polyurethanes.

Purchase invoices: Invoices of items bought.

Purdah: (1) East Indian, blue and white striped cotton-; used for curtains, often painted by hand; (2) Closely woven, but very fine cotton or linen veil, worn by the women of in India.

Pure Finish: Finish without any weighting or dressing.

Pure linen: Fabric, in which the warp and weft must consist of 100% pure Linen (usually in plain weave) and only in this case may be marked with the “Pure Linen” quality symbol of a hand raised in oath.

Pure new wool: (South African), term for items made of pure Virgin wool.

Pure spectral colour: Optimal colour, which yields the lightest colour for a given Type of colour and the most saturated colour for a given Shade of colour. The colour valency associated with the shade is characterized by maximum brightness. According to Ostwald, every colour corresponds with the sum of pure spectral colour (P) (pure colour), ideal white (W) and ideal black (B) according to the equation $P + W + B = 100$. The so-called clear bright series is created from pure spectral colour + white and the so-called clear dark series is created from pure spectral colour + black (Chromaticity diagram).

Purl: (1) A picot or small loop that edges needlework, lace, or ribbon. Sometimes spelled pearl. (Also see PICOT.) (2) Coiled gold or silver thread used for embroidery.

Purl fabric: A fabric in which both back and face loops occur in some or all of the wales. The structure may be identified by the particular knitting sequence used, E.g. 1×1 Purl fabric: A fabric which a single course of back loops alternates with a single course of face loops. Other designations like 2x2 purl and 3×3 purl are possible. A variety of patterns can be produced mainly for ladies pullovers and cardigans.

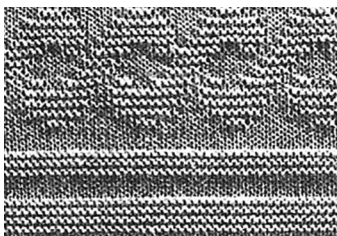

Figured Purl

Purl gaiting: See **Gaiting**.

Purl knit fabric: The semi-circular appearance is dominant on both sides of a fabric. There are several types of purl fabrics such as 1 × 1, 5 × 3, 4 × 4 purl fabrics and the simplest one is the 1 × 1 purl fabric. It is thicker, softer and warmer than a plain knit fabric and it has more elasticity lengthwise than a plain knit fabric. It can be unraveled from both ends of the fabric.

Purl Knitting: Framework knitting, the loops formed in reverse direction, both sides of the fabric looking alike.

Purl stitch: Purl stitch (reverse stitch): this is the technical reverse of the stitch where loop legs are below the neighbour stitch and the loop head is above the neighbour stitch. The reverse of a plain stitch is the purl stitch.

Purl, Facy: A general term used to describe patterned purl structures in which a design is formed from back and face loops.

Purple: Reddish violet Natural dyes (vat dye) made of the gland secretion of dead murex snails (Mediterranean and West Indian coasts. 8000 snails provide just 1 g dye). Active component: Dibromoindigo.

Purpurin: (1,2,4-trihydroxyanthraquinone), madder purple. Naturally occurring together with alizarin in the Madder (previous madder dyeing); provides reddish violet chrome lacquer.

Purse Silk: Thick silk thread, made smooth and soft; used for embroidery.

Purshed Velvet: Medieval term for velvet the pile of which was raised in a net pattern.

Purumu: Fine, silky bast fibre, yielded by the *Sida carpinifolia* in the Canary Islands; used for cordage locally.

Pushmina or Pushum: See **Pashim**.

Pussy willow: A plain weave fabric, characterized by the fine horizontal lines and made from nett silk yarns. The warp sett is much greater than weft sett.

Put: East Indian knotted rugs, made of fine white wool.

Puttee: A legging that looks like a surgical bandage.

Put-Up: Refers to the type, size, and yardage of the cone, king-tube or tube upon which thread is wound.

Putang: Narrow, very coarse homespun cotton cloth made in China.

Puttoo: (1) East Indian inferior wool cloth; used for shawls; (2) East Indian inferior goats' wool; (3) French dress goods and coating of thick but light texture, having a long nap which is of a lighter colour than the body.

Puy Lace: French bobbin lace, made in a great variety, mostly in black and white and also in silk guipures.

Puyuenchow: Another native Chinese term for pongee, made in widths of 30 and 32 inches and boiled out after weaving.

PVA: Polyvinyl alcohol fibres.

PVA+: Polyvinyl acetate fibres.

PVAL: Polyvinyl alcohol fibres.

PVC: Its full name is Polyvinyl Chloride and it is a chemically produced thermoplastic material. Most fabrics referred to as PVC are base fabrics, such as plain knitting or plain or printed cotton, that have been sprayed with coloured or colourless polyvinyl chloride. Some are stiff and heavy, some are softer. Used for aprons, protective wear, raincoats, hats, curtains etc.

PVC+: Post-chlorinated Polyvinyl chloride fibres.

PVM: Polyvinyl chloride copolymer fibres.

P.W. Osnaburg: Part Waste Osnaburg. See **Osnaburg**.

Pyjama cloth: A hard wearing cotton (once silk) fabric with a close warp and woven in stripes of a varying widths and colours. The fabric is often brushed on the right side, highly inflammable.

Pyranometer: (also incorrectly called Pyrliometer), device for the measurement of sunshine in the form of heat generated in Langley units (gcal/cm²). Often used in meteorology. Not suitable for use as a substitute for Blue scale in light fastness testing.

Pyranthrone: These are anthraquinonoid dyes with a pyrene structure. Example is a dye which can be made by heating 2,2'-dimethyl-1,1'-bianthraquinone with alcoholic potassium hydroxide – Indanthrene gold orange G.

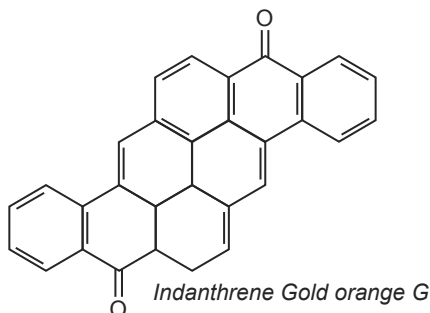

Pyrheliometer: Light sensitive measuring cell for illumination equipment, a thermoelement photometer consisting of two concentric rings with a black or white surface (hot solder points of a gold-palladium and platinum- rhodium thermoelement battery, attached to the black underside of the ring).

Pyrenean: Wool Coarse Spanish wool; used for carpets.

Pyro-: As a prefix in the designation of inorganic compounds created from water-containing ortho compounds by heating and the emission of water.

Example: Pyrophosphoric acid $H_4P_2O_7$ (from $P_2O_5 + 2H_2O$) by the emission of 1 molecule of water from two molecules of ortho acid. Salts Pyrophosphates.

Pyrocellulose: Cellulose modification that has been damaged due to excessive heating. Always contains aldehyde and carboxyl groups. Fibre damage (cellulosic fibres), tests for.

Pyroset: Original trademark of American Cyanamide Company for a durable fire retardant finish.

Pyrolysis: A chemical change brought about by the action of heat, usually in the absence of a reactive medium. Complex chemical molecules are reduced to simpler chemical units as a result of pyrolysis.

Pyrometer: Measuring instrument for high temperatures.

Pyrovatex CP: N-Methyloldimethyl phosphonopropioamide: Pyrovatex CP (Ciba) provides a method of attaching phosphorus to cellulose making use of N-methylol reactivity with cellulose. It is applied with a methylolated melamine resin using a phosphoric acid catalyst by a pad-dry-cure process. The high nitrogen content of melamine provides synergistic activity to the phosphorus of the flame retardant.

Q

QD (in zipper): Quick disassembly zipper.

Qiviut: Down undercoat fibre from the musk ox.

QR (in zipper): Quick release zipper.

QS-process: Squeezing/suction technique in accordance with the principle of Capillary dehydration developed by Pfersee. This is one of the low wet pick-up techniques; liquor reduction in the goods through capillary liquor exchange. Material which has been conventionally padded and squeezed in the first padder nip to the usual liquor absorption is brought together with the same, but dry fabric, and pressed against it in the 2nd nip. This results in removal of the excess liquor (adhering liquor), leading to a reduction in the liquor uptake by a further 15–40%. Liquor treatment squeezing/suction methods on cotton approximately 40%. *Advantages* – Low wet pick-up. Principally used in resin finishing.

Quadrant scales: Yarn scales, for determining the weight of a certain reel length, by which the yarn count is determined.

Quadrille: French for checked (small chequered pattern). Now a general term for an overall design of small squares, woven or printed. The illustration is Satin ‘quadrille’.

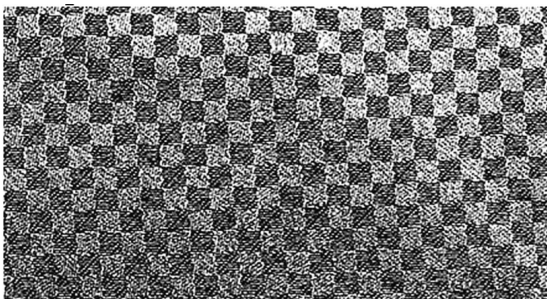

Quadripolymer: A polymer made from four distinct monomers.

Quality: Quality is the sum total of all characteristics and features of a product or an activity which relate to their suitability for fulfilling set requirements.

Quality assurance: This is an essential measure for controlling production, to keep complaints about products within limits, to detect faults and eliminate them. In the textile industry, however, thorough quality assurance comes into conflict with ever shorter batch lengths and project times, and with ever smaller profits from finishing. In order to be able to produce economically in terms of time and costs, in the last few years, many firms have invested in the field of quality assurance, under the motto “quality is profitable”.

Quality binding: A strong, twilled, wide tape, made of coarse worsted; used for binding carpets.

Quality assurance: The term quality assurance covers all the processes within a company that contribute to the production of a quality product. It does not just cover the final testing of the product before shipment and it is not solely concerned with testing the product.

Quality control: The term quality control used by itself has a very narrow meaning and it is generally taken to mean the maintenance of product quality by the regular inspection of critical stages in the manufacturing process. The inspection is carried out on a limited number of items selected as being representative of the current production and the results recorded chronologically on control charts.

Quality of conformance: This is a measure of the fidelity with which the product taken at the point of acceptance conforms to the above design. This is the area that is usually thought of as the province of quality assurance. However, the overall quality depends also on the design as performance cannot be introduced at this stage, if it is not present in the original design.

Quality of customer service: This is a measure of factors such as the speed of response to orders, the response to customer returns and complaints, the speed and quality of installation and servicing and the initial availability of the product.

Quality of design: This can be considered as the value inherent in the design. It is a measure of the excellence of the design in relation to the customer’s requirements. The production of a quality product starts with its design. The initial meeting of the customer’s requirements and the continued functioning of the product throughout its lifetime depend on choice of materials, construction and processes.

Quality of use: This is a measure of the extent to which the user is able to secure continuity of use from the product. Provided material is being produced which conforms to specification, the length of time the product lasts in use depends on the original design.

Quality-related abbreviations:

TQM = Total Quality Management

CAQ = Computer Aided Quality Assurance

QA = Quality Assurance

PSG = Problem-Solving Groups

FMEA = Failure Mode and Effects Analysis

SQC = Statistical Quality Control

SPC = Statistical Production Control

LIMS = Laboratory Information and Management System

Quality sample: Representative sample for the final quality of the goods.

Quality standards: Requirement profiles.

Quarantain: Fine French woollen cloth, originally of 4,000 warp ends.

Quart: Measure of volume; in the United States of America, a liquid quart is 32 fluid ounces or approximately 946 millilitres; in Canada and Britain, a quart is 40 fluid ounces, or approximately 1137 millilitres.

Quarter: (1) English measure for carpet width 1 quarter = 9 inches = approximately 23 cm; (2) German carpet measure, now obsolete, equivalent to 1/4 cubit, or approximately 17 cm.

Quarter-blood wool: One of the grades in the standards for wool.

Quatre fils: Very strong French sail cloth, made with four-ply warp.

Quartz fibre: Pure silica that has been melted and drawn into glass-like fibres. It is used for heat resistance and high dielectric strength. Quartz is a fusion product of silicon oxide which does not show any crystal arrangement when cooled slowly (lattice silicate). The way in which these are obtained corresponds to that for glass fibres. Quartz fibres are stable up to a temperature of 1200–1300°C, and the melting point lies at around 1700°C. Resistance to acids is very good, and resistance to alkaline solutions is good.

Quaternary (from the Latin *quattuor* = 'four'): Quadruple substitution, e.g. by alkyl groups, such as with the most important quaternary ammonium compounds and phosphonium compounds, where the alkyl complex occurs as a cation.

Quaternary ammonium salts(softeners): Quaternary ammonium salts are extremely important fatty acid derivatives. The quat's cationic charge is permanent, being maintained at all pHs. In addition to imparting softness, quats reduce the static charge on synthetic fabrics and inhibit the growth of bacteria. Quats are therefore used as anti-statics and germicides as well as

softeners. Cationics containing two C18 fatty tails attached to the nitrogen impart very soft, fluffy hand to textile products. Cationics based on di-tallow amine are used as home laundry rinse-added and dryer-added fabric softeners as well as mill applied softeners.

Quaternization of monochlorotriazine reactive dyes: Normally, monochlorotriazine reactive (MCT) dyes react with cellulose only under alkaline conditions. However if one adds tertiary amines to a neutral printing paste, the reaction can proceed during steaming even below pH7.

Queen: Commercial variety of upland cotton from Arkansas; the staple measuring 22–25 millimetres; the yield is 34–36%.

Queen's cord: The fabric width changes very slightly when leaving the knitting zone. It is a very stable and rigid fabric.

Queen stitch: Used in embroidery, consists of a square inside of another with parallel sides.

Quench: (1) A box filled with water into which fabric is run after singeing to prevent sparks or fires; (2) See **Cabiner**. (Also see **Quenching**.)

Quench spacer: The “quiet” zone below the spinneret in which there is no quench airflow. Quench spacer distance is important in controlling fibre orientation and birefringence.

Quenching: The cooling of fibre filaments after extrusion by carefully controlled airflow. See **Crossflow quench**, **Inflow quench** and **Outflow quench**.

Quercitron: A bright yellow mordant dyestuff, yielded by the bark of an oak (*Quercustinctoria*) in Southern United States of America.

Quetsch: The nip rollers of a padding machine.

Quick copper detection in effluent or water: 50 ml of the water to be tested is added to 2 ml of a light coloured oleic acid. After the mixture has been thoroughly shaken, the creaming oil layer reveals a weak to strong green discoloration in the presence of copper(copper oleate). The presence of more than 1.2 mg/l of iron upsets this colour reaction.

Quick dyeing: Rapid dyeing process for synthetic fibre material. The reduction in time is enabled by rapid heating of the dyeing liquor and by a rapid cooling phase. It is predominantly polyamide fibres which are dyed by this method.

Quick lime (calcium oxide): White to grey in colour, formed through heating and roasting of calcium carbonate (chalk, limestone, marble) CaCO_3 . It is fire-resistant and melts only at 3000°C. It is used for furnace lining, etc.

Quill: A light, tapered tube of wood, metal, paper, or plastic on which the filling yarn is wound for use in the shuttle during weaving.

Quill embroidery: See **Canadian embroidery**.

Quill point (in feathers): The section of quill extending beyond the section of barb attachment.

Quill, shaft (in feathers): The section of quill from which the barbs emanate.

Quill (in feathers): The stem or central shaft.

Quilling: The process of winding filling yarns onto filling bobbins, or quills, in preparation for use in the shuttle for weaving.

Quilot: The fine, white and glossy inner fibre, yielded by the abaca plant: used for very fine fabrics by the natives, but only little of it is found on the market.

Quilt: Piqué.

Quilt lining: Lining material from quilted non-woven fleece (padding), wadding or foam material on lining material, duchesse, serge, etc.

Quilt wadding: Goods of the Maliwatt fabrics; for wadding, lining purposes, layer base for tensioning purposes, insulating material, etc.; 200–425 g/m.

Quilting: Plain or printed cotton, viscose or nylon fabric mounted on to a layer of 2 oz wadding (usually polyester) and held with rows of machining in diamond pattern or parallel rows. A backing usually added before quilting—this may be a thin layer of plain coloured knitted nylon or another fabric to contrast with or match the outer material. This is referred to as double-sided quilting. All quilting is warm but light. It is used for making robes, dressing gowns, bed jackets, anoraks, children's clothes, snow suits, jackets, boleros, belts and also small pieces of quilting can be used for collars, pockets, yokes and lining hoods.

Quina: A modified nylon fibre with a trilobal cross-section, is a polycondensate of diamine diphenyl methane and decane dicarboxylic acid. It is distinguished by its silk-like handle and regarded as synthetic substitute for pure silk.

Quintain: Very fine lawn, made in Quintain, France; used for embroideries and laces.

Quintes: The best grade of French linen.

Quomotanetu: Very strong bast fibre, yielded by a species of the Asclepiadaceae in South Africa.

R

RA: Ramie.

Ra: Ramie.

R.M.M.: Relative molecular mass; proper modern term instead of *molecular weight*. 'Relative' is used because the mass is in proportion to one twelfth the mass as carbon-12.

Rabanna: A coarse fabric made of raffia fibres in Madagascar.

Rabbit hair: (1) The fur from the common or wild rabbit. Used for hats and as substitute of vicuna, for shawls, etc.

(2) Long rabbit hair is used in combination with other fibres such as wool, to add softness and interest to a fabric. The percentage of rabbit hair included is normally specified on the label.

Rabo de Leon: Very strong leaf fibre, similar to Manila hemp, yielded by a species of the *Sansevieria* in the Philippines; used for cloth by the natives.

Raccroc Stitch: Used in joining the separately executed pieces of lace together into a larger piece.

Race: In pile fabrics the narrow space between two adjoining rows of pile.

Race-board: The flat part of a sley in front of the reed.

Raschel Knit: A warp knitted fabric in which the resulting knit fabric resembles hand crocheted fabrics, lace fabrics, and nettings. Raschel warp knits contain inlaid connecting yarns in addition to columns of knit stitches.

Raschel Lace: Raschel Lace fabrics are often made on a base of net fabric with a pattern formed from inlay yarns. They are used for foundation and lingerie, bridal and formal wear, and as trimmings. See **Lace, raschel**.

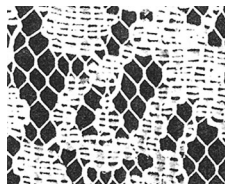

Raschel Lace

Raschel net: Raschel lace fabrics are often made on a base of net fabric with a pattern formed from inlay yarns. They are used for foundation and lingerie, bridal and formal wear, and as trimmings.

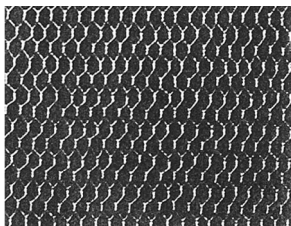

Raschel net

Rack: A warp-knitting measure consisting of 480 courses. Tricot fabric quality is judged by the number of inches per rack.

Rack, in warp knitting: A unit of length measure consisting of 480 courses. This is the working cycle of 480 knitted courses of warp knitting.

Racked Stitch: A knitting stitch that produces a herringbone effect with a ribbed back. It is employed in sweaters for decorative purposes or to form the edge of garments. The racked stitch is a variation of the half-cardigan stitch; it is created when one set of needles is displaced in relation to the other set.

Racking: A term referring to the side-to-side movement of the needles of the needle bed of a knitting machine. Racking results in inclined stitches and reduced elasticity.

Raddle: Raddle is a board at least as long as the width of the warp with evenly spaced pegs or nails (1/4"–1" apart). Groups of warp ends are placed in each raddle space and the warp is wound on the warp beam with the raddle secured on the back beam. The width of the warp in the raddle and the number of ends in each space determine the density and width of the warp on the warp beam. (Raddles are used for warping methods in which the warp is wound on the warp beam before being threaded through the heddles.)

Raddle cross: Raddle cross is formed by groups of warp ends on the opposite end of the warping board or reel from the threading cross (which is formed of individual ends). The number of ends in each group is equal to the number of ends to be placed in each dent of the raddle.

Radial balance, in designing: This is when design elements radiate from a central point, as the spokes of a wheel or in the natural form of a daisy.

Radial Dyeing Machine: Packing system dyeing machine with circulating liquor. The material block is lifted after dyeing on the material carrying plate

and is spun in a conventional centrifuge, the upper rim of which can be removed. This kind of special centrifuge is no longer in use, since a normal centrifuge can be used after a batch has been dyed in the radial dyeing machine. This includes other batches such as piece goods, hanks, bobbins. Radial dyeing machines are also used for dyeing wool, cotton, viscose, polyamide, acetate, polyacryl nitrile, hair and rags.

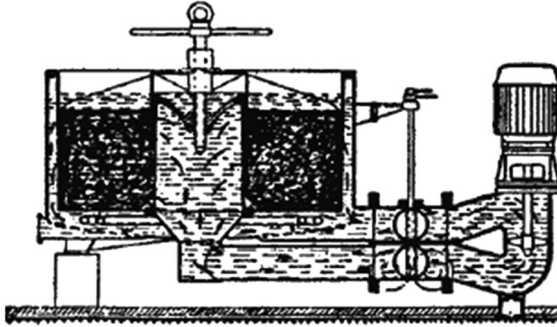

A radial dyeing machine

Radian: The plane angle between two radii of a circle which intersects the circumference of the circle making an arc equal in length to the radius.

Static friction: Friction developed between two touching bodies at the time one body starts to move relative to another.

Radiant Energy: A form of energy consisting of the electromagnetic spectrum, which travels at 299,792 kilometers/second (186,206 miles/second) through a vacuum, and more slowly in denser media (air, water, glass, etc.). The nature of radiant energy is described by its wavelength or frequency, although it also behaves as distinct quanta (“corpuscular theory”). The various types of energy may be transformed into other forms of energy (electrical, chemical, mechanical, atomic, thermal, radiant), but the energy itself cannot be destroyed.

Radiant flux density: Rate of flow of the radiant energy past the material.

Radiant Power: Energy per unit time emitted, transferred, or received as radiation.

Radiation singeing: Indirect Singeing, without contact between material and flames. The effect is achieved by re-radiation from bricks heated to high temperatures.

Radicals: (Lat: radix = root) groups of atoms with free valency that cannot exist under normal conditions (unbound electrons). For example, if triphenyl

methyl chloride is treated with finely-distributed silver in benzene in a vacuum, a yellowy solution is produced. If this solution is treated in air, the yellow colour disappears.

Radio: Plain woven lustrous lightweight, sheer French silk dress goods, comes printed or dyed.

Radio-frequency drying: Use of radio-frequency electromagnetic radiation for drying textiles. The application of RF to wet goods results in the selective heating of the water, which has a partial polarity, because the molecule must do work to align in the RF field causing heat generation within the water droplets. Non-polar materials, i.e., fabrics, are unaffected. RF drying is very uniform and energy efficient when airflow patterns through the dryer are properly designed and controlled.

Radio Frequency Technology: This technology is based on the peculiar characteristics of dielectric (insulating) materials such as water. Water molecules are subject to polarization when put in to an electric field, this polarization corresponds to a deformation and reorientation of the molecules in accordance with the field itself. In an alternated (oscillating) electric field water molecules invert their own polarization at each single inversion of the field. Furthermore, water molecules invert their polarization at the same frequency of that of the electric field they are subjected to, dissipating energy due to their inter molecular friction, this energy is called dielectric loss. The intermolecular friction generates heat which increases water temperature, discharging steam in the environment. The more frequent are the oscillations, the higher will be the energy absorbed by the material. This is why the RF driers use upto 27 millions inversions per second.

Radiometer: An instrument used to measure radiant energy.

Radium: A plain weave lustrous fabric that has the draping quality of Crepe, but the crispness of Taffeta. The fibres used include silk, viscose, acetate, triacetate. Used for lingerie, robes, blouses, and as lining fabric.

Radzimir: A very fine, lustrous, stout silk dress fabric in England, made in plain weave but weft ribs; it is usually dyed black and used for mourning.

Raffia: A fibre obtained from the leaves of the raffia palm, *Raphiaruffia* (South Africa, Madagascar, South America). Flat, brown/yellow bast strands (for gardener bast and as braided bast for arts and crafts), easily divided lengthways to form solid fibre elements (for string and coarse yarns).

Raffia bast: See **Raffia**.

Rag: Rug Made of strong cotton warp and stripes of various coloured rags, forming patterns.

Rags: (1) Are classified: Carpets, skirting (women's dress goods and men's lining), merino (very fine women's dress goods), flannel, linsey (all other wool fabrics containing cotton), serge (braids, tresses, etc.), new (new clippings from tailors), rubbish (the lowest grades of rags). Each of this is sorted again according to colours. Ragusa Lace (Dalmatian needle-point lace of early origin, Similar to the Point Venise. At the present patterns formed of picot edge silk or gold tape are united with brides to form laces.

(2) Term for the remains of worn, more or less worn-out items of clothing from households.

Raglan: A loose overcoat, the sleeves of which are continued over the shoulders up to the collar. Named after Lord Raglan, who devised a similar garment for the protection of his soldiers during the Crimean war, the idea being to increase their fighting efficiency by the greater freedom of action afforded by the peculiar shoulder.

Raglan sleeve: A sleeve with armhole line extending from the front and back scye to the neck point so that the shoulder section is joined to the sleeve crown, eliminating the conventional shoulder and sleeve head seams.

Railroad Canvas: Black or white and considerably sized cotton or linen fabric made with open texture; used for embroidery.

Rails: The metal bars on which the spindles of a down twister are mounted.

Railway Stitch: Similar to leviathan stitch.

Rainbow Effect: Produced in calico printing by the different coloured fields shaded into each other at the edges. Raincloth Twilled or satin weave light cotton, wool or silk cloth, dyed in the piece and made waterproof by rubber, oils, etc. used for raincoats. Rainproof same as waterproof.

Rain-Grown-Cotton: Cotton cultivated under natural climatic conditions (Irrigated cotton).

Rainwater harvesting: The collection and use of rainwater by a household for direct use in toilet flushing, cleaning purposes, garden watering, etc., but not normally drinking water.

Rain resistance: Water spotting fastness.

Raincoat fabric: Water proof fabric, prepared for making rain coats.

Raised check: Fabric figured with extra warp on a plain ground.

Raised Colours: In textile printing various dyestuffs which are treated after printing, in a bath which will fix or develop the colour

Raised Embroidery: Made with padded or raised patterns over a flat foundation.

Raised Fabric: Same as napped goods.

Raised finish: (brushed finish, napped finish) Brushed fabric.

Raised jersey: A term used to describe a medium-weight knit fabric of fairly open texture, that has been brushed on right side to add warmth and give an attractive fuzzy effect. Often made in random colour coordinating yarns. The fibre is usually acrylic. Used for sift suits, dresses, coats.

Raised resist print: Printing of pigment white and/or pigment dyes. Subsequent drying is followed by friction texturizing, condensing and raising. Produces a raised pile in non-printed areas, whereas printed areas are not raised.

Raised Stitch: In Berlin work, is called also velvet stitch and is a variety of the plush stitch; it is suitable for raised wool work. The loops are being cut and brushed, imitating the pile of the velvet.

Raised surface fabric, in textile fabrics: A fabric which has an intentionally lifted fibres or yarns such as pile, napped, tufted, flocked, or similar surfaces.

Raised Velvet: Having the pattern formed by a higher pile than that covering the ground. See **Pile over pile**. Raised work in hand-made laces the raised edge of the sprigs.

Raising: (Napping, Sueding) The production of a layer of protruding fibres on the surface of fabrics by brushing, teasing or rubbing. *Note:* The fabric, in open width, is passed between rotating rollers covered with teazles, fine wires, carborundum, etc., whereby the surface fibres are lifted or broken to give the required effect.

Raising teasels: Natural teasels on thistle heads that are used for Raising. The thistle heads can be inserted into rods (rod teasels) or attached to rotating rollers (roller teasels) that themselves rotate on a cylinder.

Rajah: Made of Silk, rayon in plain- warp yarn is 4 thread organzine – filling is heavier. Made from a tussah silk or certain silk wastes. It belongs to the pongee family of silks. Made from irregular yarns, so has slubs and irregularities but thicker than shantung. It is rather compact and strong. Has a pebble-like feel and appearance. Comes in all colours as well as natural ecru shades, but often warp and filling are different colours (irridescent effect). A soft, strong, plain weave silk fabric with rough texture. It was first made, not in the East, but in the US. Tussah silk was normally used, but it is now made from acetate, triacetate, nylon, polyester. It is very similar in appearance and weight to Pongee.

Ram's Wool: Shorn from male sheep; it is stronger than other wool.

Ramage: French for branching patterns.

Ramina: Braiding made from Ramie for hats, bags, arts and crafts, etc.

Rambouillet: French merino wool of lustrous, strong, long staple.

Random Tumble Pilling Tester: Device for testing Pilling behaviour, consisting of six round containers lined with cork or plastic. Three samples of a type of material whose edges have been bonded with glue are placed in each round container, together with 25 mg of cotton lint. The samples are tumbled around for 1 hour by a paddle rotating in the round container (1200 rpm). The cotton lint is used to make the pilling effect visible. Visual evaluation. Graded from 1 (extremely strong pilling) to 5 (no pilling).

Rameses: Commercial variety of early maturing upland cotton, the staple measuring up to 26 millimeters; the yield is 32-33 percent.

Ramie: A strong vegetable fibre, white silky colour, yielded by the Boehmeria plant of the nettle family also known as China Grass, growing in China, America, etc. It is difficult to decorticate. Method of obtaining fibre: manually or automatically (Ramie decorticator) from freshly cut stems and by cottonizing. The Ramie stem structure is comparable to that of the Flax stem structure. Raw fibre: pure white, fine, silky gloss. Individual fibres: 50–260 mm long, \varnothing 20–100 μ m. Owing to its porousness it is used for underwear. Ramie is expensive to produce and is usually mixed with other fibres, such as wool. Fabrics resemble Lutex.

Rampoor Chuddah: Very fine and soft East Indian twilled woollen dress goods in red, white and gray colours.

Rampur chadars: Woollen hawls made in Ludhiana, India. The name Rampur chadar is after the wool that came from Rampur Bushair in Himachal Pradesh, India. Once the city had 2000 shawl weavers and 500 wool manufacturers, even though the place now is famous for the hosiery manufacture. Although shawls were not patterned, they were made in five popular colours ivory white, scarlet, turquoise, blue and grey with slightly decorated ends.

Ran: (1) Rope measure, 20 yards; (2) Silky, long fibre, yielded by the Malachra capitata in tropical Africa and America; used as substitute for jute.

Random tumble pilling tester: Device for testing Pilling behaviour, consisting of six round containers lined with cork or plastic. Three samples of a type of material whose edges have been bonded with glue are placed in each round container, together with 25 mg of cotton lint. The samples are tumbled around for 1 hour by a paddle rotating in the round container (1200 rpm). The

cotton lint is used to make the pilling effect visible. Visual evaluation. Graded from 1 (extremely strong pilling) to 5 (no pilling).

Random winding: A method of winding cones and cheeses in which the number of winds per double traverse is constant and the wind decreases as the diameter increases.

Random-laid web: A term sometimes used to describe a web or batt produced by air laying.

Random-sheared carpet: A pile carpet with a textured face produced by shearing some of the loops and leaving others intact.

Random Yarn: Fancy filling yarn, having a strand wound around a different coloured core.

Range: A group of fabrics (or products) designed, developed, and edited to be shown and sold to the market each season.

Range planning: Managing and controlling events to put together a range.

Range Wool: Wool produced under range conditions in the West or the Southwest. With the exception of Texas and California wools, it is usually classified as territory wool.

Rangoon; East Indian cotton, having a short and weak staple of dull and stained brown colour; contains much leaf.

Rankine scale (R): Degrees Rankine is a normal unit of temperature in England and the USA: start of the scale (like Kelvin) at absolute zero is 0°R, freezing point 491.67°R, vapour point 671.67°R. Fundamental difference between freezing point/vapour point is 180°R, which is equivalent to 180°F; 1°R is therefore equal to 1°F:

$$\begin{aligned} 1 \text{ Rankine unit} &= 1 \text{ Fahrenheit unit} \\ &= 5/9 \text{ Celsius unit} \\ &= 5/9 \text{ Kelvin unit.} \end{aligned}$$

Rap: A skein, containing 120 yards of yarn.

Rapatelle: Open-work horsehair cloth, used for sifting flour.

Rapid ager: Most common continuous steamer especially for brief steaming (1–10 min) and high outputs in roller printing for vat and developing dyes, also for discharge printing. There is a row of driven guide rollers above and below. The fabric runs in a zigzag arrangement, alternately downward and upwards, each facing the rollers with the reverse and printed side of the fabric, therefore cannot be used as a screen printing steamer. The oven roof is double-

walled and steam heated (protection against spotting), with an exhaust duct or fan. Steam temperature usually 101–103°C. The material is preheated and the air is evacuated (particularly necessary for vat printing) in a heated pre-chamber.

Rapid bleach process: All processes, in which the material to be bleached is exposed to the bleaching bath for less than 10 min.

Rapid cleaning of padders: The automatic rapid cleaning of padders makes it is possible to economically dye even small dyeing batches on a continuous dyeing plant or in accordance with the pad batch process. The squeezing and guide rollers are automatically cleaned according to a pre-selected program when the batches are changed. The padding trough is automatically emptied, cleaned and filled with new liquor. The cleaning time is less than 8 min.

Rapid cross linking: See *Shock-cure process*.

Rapid desizing : Continuous Desizing by a large quantity of desizing agent (usually bacterial amylases) and subsequent steaming, whereby the starch is decomposed at an accelerated rate.

Rapid drier: In the rapid drier, in contrast to the Pressure boiler, heated fresh air is blown through cross wound yarn packages and discharged as moist exhaust air and is not reused.

Rapid dyeing machine: They differ from conventional dyeing machines because of the use of high performance pumps (increase in liquor throughput to approx. 150 l/min/kg), heaters (heating-up rate of approx. 15°C/min), heat exchangers, shock dyeing devices, short liquors up to 1 : 5 and less (e.g. due to dividers), change of liquor direction, etc. On the other hand there is an increase in the energy used for heating (HT = although the temperature is slightly higher, time is reduced) and pumps for higher liquor throughput (compensated by shorter pump running time).

Rapid dyeing process Term for shortened dyeing processes. Thanks to reduced treatment times, rapid dyeing processes make it possible to notably reduce finishing costs. However, it is only possible if operating reliability and reproducibility are retained.

Rapid fill: Rapid transfer of dye liquors into a dyeing machine, normally for reducing the dyeing time.

Rapid fixation dyeing units: Small continuous plant for universal application or as washing/rinsing machine for pre-treatment (desizing, bleaching). The steamer can be flooded and used as a washing plant. Counter current principle; extremely low water consumption, Modular structure.

Rapid mixers, rapid stirrers: are high speed mixers. They differ due to the size and shape of the stirrer assembly (mixing heads), upon which the fine distribution depends: stationary, portable or transportable. In textile finishing above all for the application of printing thickeners and dye solutions.

Rapid steam generator: Boiler with up to 1000 kg/h performance.

Rapid wetting Agents: Highly powerful wetting agents like dioctyl sulpho-succinate, sulphonated modified ester. It is anionic stable over pH of 1 – 10, and hardness upto 300ppm. Used as an auxiliary in wetting the fabric and as a dissolving assistant.

Rapier loom: Looms in which either a double or single rapier (thin metallic shaft with a yarn gripping device) carries the filament through the shed. In a single rapier machine, the yarn is carried completely across the fabric by the rapier. In the double machine, the yarn is passed from one rapier to the other in the middle of the shed. The rapier weaving machines are the most flexible machines on the market. Their application range covers a wide variety

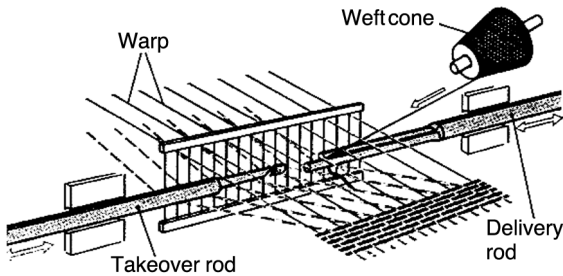

Weft insertion by rapier

of fabric styles. Their present **weaving speed of about 600-700 strokes/min** is the result of the use of a state-of-the-art construction technique, characterized by the use of gear sets without plays and by minimum vibrations of the reed, the slay and the heald frames.

Ras de Cypre: French silk dress goods with cross ribs; comes usually in black.

Ras de Florence: Fine woollen men's wear, woven in fancy coloured twills.

Raso: Italian for satin.

Raschel batt-on-base carpet: Textile floor covering. Instead of pile yarns a fibre nonwoven is used in combination with auxiliary yarn using the raschel technique to form a bouclé carpet, which is then shorn to produce Velvet pile carpets.

Raschel carpet: (knit-woven carpet), a velour carpet manufactured on a raschel machine, where the ground weave is woven at the same time. The pile threads, which are loose in the base material to start with, are fixed in place using reverse-sided coating (latex, artificial resin). Similar appearance to tufted carpets. Usage: e.g. stair carpet material.

Raschel knit: Raschel is the name of a machine invented to produce this type of fabric. The machine uses latch needles set in a vertical plane and produces a wide variety of fabrics, particularly heavier complex structures. Fabrics are not conventional knit construction but appears to be partly woven in texture. These fabrics are often printed, and some are very transparent. Normally made in polyester this fabric is used for blouses, dresses, curtains, bedspreads, depending on the design.

Raschel knitted fabric: Warp-knitted fabrics made on the raschel machine (from the French: Rachel) for curtains (raschel curtains), lace, carpets, tulle, fashion materials (outerwear, underwear), etc.

Raschel knitting: See **Raschel knitted fabric**.

Raschel tulle: Net-like knitted fabric that is manufactured with two retracted guide rails in accordance with a pattern. Each warp thread has a weft thread assigned to it. The effect of the honeycomb-like openings is not shown to its best advantage until finishing has taken place.

Rateen: English all-wool lining serge, similar to frieze.

Rat-tail cord: A small, filled, tubular cord of braided or woven construction, about 3mm in diameter. The woven version is usually of tubular satin weave.

Ratch, spinning: The distance between the nip of the front rollers and that of the back (prior set of) rollers is referred to as the ratch and needs to be carefully selected in relation to the fibre length characteristics of the material being processed. Too low (or short) a ratch leads to many fibres being simultaneously gripped by both sets of rollers and possibly broken, while too great (long) a ratch leads to excessive floating fibres and poor fibre control. Although the nominal, or theoretical, ratch is easy to calculate the actual or effective ratch is more complicated to derive, depending upon a number of factors, such as the sliver thickness (linear density), inter fibre-frictional forces and cohesion.

Ratchet effect: Relates to wool scales and the fact that they hook onto each other as in the so-called directional friction effect (DFE) assumed to play a major role in Felting.

Ratchet lock slider, in Zipper: A slider with a locking mechanism that permits the slider to slip along the chain upon application of a predetermined

force so as to prevent damage that would impair either the service or use of either the slider or the chain.

Rate of dyeing: Rate at which the dyeing bath is exhausted. A suitable measure is the inverse of the Time of half-dyeing or the time after which 70% of the dye has been absorbed.

Rate of evaporation: Increases with increasing temperature, because the average molecular speed increases at the same time, and therefore so does the percentage of molecules with above average speed, which can escape from the surface.

Rate of fixation: (1) In reactive dyes the fixation speed is characterized by the period of time in which a stable bond is formed between the dye and fibre molecule. It is dependent upon the reactivity of the reactive group in the dye molecule, alkalinity of the fixation medium and temperature. (2) In disperse dyes the fixation speed depends upon the diffusion speed of the dye in the synthetic fibre, which is determined by the dye concentration and temperature and pressure relationships during fixation.

Ratiné: (1) A French word meaning fuzzy, this a rough pebbly woollen fabric made of novelty yarn with a fancy twist, and similar in finished appearance to Chinchilla. Used for men's overcoats.

(2) A plain-weave, loosely constructed fabric having a rough, spongy texture which is imparted by the use of nubby plied yarns. It is made from worsted, cotton, or other yarns.

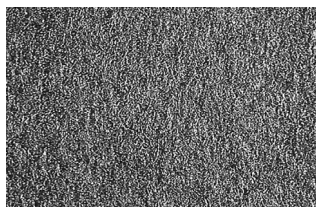

(3) A variant of spiral yarns in which the outer yarn is fed more freely to form loops that kink back on themselves and are held in place by a third binder yarn that is added in a second twisting operation.

Ratine' Finish: Woollen fabric character with wave-like appearance on the surface.

Ratine lace: A machine-made lace, the ground work of which consists of heavy loops rather than mesh.

Raumois: Coarse and unbleached French ticking.

Ravel: A type of comb or rail with projecting teeth for separating and guiding warp ends.

Raveled strip test, in fabric testing: A strip test in which the specimen is cut wider than the specified testing width and approximately even number of yarns are removed from each side to obtain the required testing width.

Raveling: The process of undoing or separating the weave or knit of a fabric.

Raven's duck: A very heavy linen fabric in 2 x 1 twill weave, used as sail cloth.

Raw cotton: Ginned lint that has not been subjected any textile manufacturing processes.

Raw cotton composition: 83.71% cellulose, 6.74% water and impurities 0.61% grease, wax (Cotton wax), 5.79% hemicellulose, pectins, 1.50% proteins, 1.65% ash. According to Bowman: 91.35–90.80% cellulose, 0.40–0.42% wax-oil-grease, 0.53–0.68% protoplasm, 0.22–0.25% mineral components, 7.50–7.85% water.

Raw fibre: A textile fibre in its natural state, such as silk “in the gum” and cotton as it comes from the bale.

Raw linen: Unbleached linen.

Raw silk: Non-degummed Silk (grège silk), still glued with silk gum and non-twisted individual threads.

Raw wool: Wool or hair of the sheep in the grease, pulled, or scoured state. See Wool, raw. (greasy wool), is shorn Wool, which still contains dirt. It contains 20–50% pure fibres, 6–17% wool fat, 10–30% wool grease, 20–40% impurities and (air dried) up to 18% water.

Rayadillos: Wide cotton goods in the Philippines, made usually in narrow blue and white warp stripes.

Raye: French for striped. Now, a general term for lengthways stripes made by colour weaving, weave interchange, varying warp density, or printing. The illustration shows Satin raye.

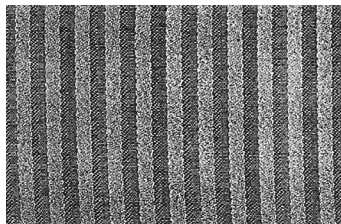

Rayleigh: Irregular bars in guipure lace.

Rayon: The earliest man-made fibre, from cellulose such as wood or cotton. Viscose, modal, acetate, cupro all are basically Rayon and hence now specific name are used.

Rayon fibre: A manufactured fibre composed of regenerated cellulose as well as manufactured fibres composed of regenerated cellulose in which substituents have replaced not more than 15% of the hydrogen of the hydroxyl group.

Reactants: Chemicals taking part in a reaction.

Reaction chamber Chamber, usually mobile, for heat and moisture treatment (hot air and steam heating) of piece ware batch rolls after padding with bleaching agents or dyes on a pad-roll machine.

Reaction rate: A measure of how fast a chemical reaction occurs Many factors affect reaction rates. One very big factor is temperature. Although the range is large, many reaction rates approximately double for each 10°C temperature rise. For example, a reaction may be 4 times as fast at 50°C as it is at 30°C. This is the reason that many dye processes are done at high temperature.

Reactive dye: A dye which attaches to the fibre by forming a *covalent* bond; also called fibre reactive dye Reactive dyes are known for their bright colours and very good to excellent lightfastness and washfastness, though poor resistance to chlorine bleach. There are several broad classes of reactive dyes. Most are intended for cellulose fibres, but some are intended specifically for wool. The most popular reactive dye family for textile artists is the Procion® MX family. Other reactive dye families reasonably available to art dyers include Procion® H, Procion® H-E, Remazol®, and Cibacron® F (equivalents to the MX, H, H-E and some of the Remazol® lines are available from many dye manufacturers; note that Procion®, Remazol® and Cibacron® are trade names of specific companies). Reactive dyes may be more expensive than other dye families suitable for the same fibres, especially when very dark or dull colours are considered. They are the newest class of textile dyes, first introduced commercially, for cellulosic fibres, in 1956, one hundred years after the development of the first synthetic dye. Within a family, the range of colours available as “pure” dyes (as opposed to mixtures) is typically quite small – a dozen or fewer. Against this, reactive dyes of the same family can generally be mixed to produce a very wide range of colours, while retaining good application characteristics and brightness. The reactivity among families varies widely, so some are easily applied at room temperature, some at boiling temperature and others at intermediate temperature. All types are suitable for *exhaust* dyeing, and many types are suitable for pad-batch (see padding)

dyeing and for printing. Apart from cost, the biggest commercial drawbacks to reactive dyes are that they require large amounts of electrolyte (salt) in most processes, and extensive rinsing and hot washing after dyeing to remove unfixed and hydrolyzed dye.

Reactive dyeing: There are two types of reactive dyes and these can be distinguished from each other by their reaction mechanism: those that react by addition and those that react by substitution.

- (a) Addition reaction of reactive dyes. On the one hand, these dyes react with the fibre via a nucleophilic addition reaction such as, for example, the vinylsulphone compounds.
- (b) Substitution reaction of reactive dyes. Nucleophilic substitution is another reaction route. In this case, the reactants are halogen-substituted, nitrogen-containing heterocyclic groups, the nucleus of which usually consists of a triazine or pyrimidine ring. These active groups are already available to react because the halogen atoms (chlorine and fluorine) are immediately replaced by an active basic group on the fibre.
- (c) Combined substitution and addition reaction of reactive dyes. Dyes which react both according to a nucleophilic substitution and a nucleophilic addition at a double bond represent a special case.

Reactive group for dyes: The chromophore component of a reactive dye produces the colour shade and determines its substantivity. The reactive group determines the type of bond between the dye and the fibre and, therefore, some of the dye's performance characteristics.











In addition to the fastnesses, dye/fibre bond and performance characteristics, the reactive groups also determine the fixing value when dyeing with a reactive dye. Basically there are two types of reactive group: (a) The reactive groups which exchange basic nucleofuges for a dissociated hydroxyl group. Among these are the heterocyclic aromatics such as triazine, pyrimidine and benzopyrazine derivatives. (b) The reactive group which can add a functional group and a proton to the fibre. This group is represented by the vinylsulphones.

Reactive resin: (reactive cross linker, reactant). Resin finishing agents which, under certain crosslinking conditions, preferably react with cellulose and to a lesser extent with itself (unlike Self-crosslinking resins) such as certain methylol compounds (e.g. Dimethylolethyleneurea) or epoxides, chlorohydrins and d-ivinyll sulphones.

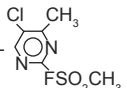
Reactive silicones: Elastomeric, amino functional and epoxy functional silicones will give a modest boost to DP performance. The elastomeric silicones add resiliency to the fabric improving wrinkle recovery. The amino and epoxy

functional improve fibre and yarn slippage, reducing the transmission of the wrinkling force to the fibre. Also wrinkles will fall out easier. These products are often included with conventional resins to boost performance.

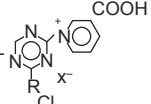
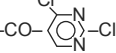
Reactive systems: The chemical group on which reactive dyes are made. There will be one or more reactive group which can react with the fibre sites. Major reactive groups are given below.

- | | | |
|-------|--|---|
| I. | $(\text{Fb}) -\text{NR}-$  | dichlorotriazhe |
| II. | $(\text{Fb}) -\text{NR}-$  | monochlorotriazine |
| III. | $(\text{Fb}) -\text{SO}_2-\text{CH}_2-\text{CH}_2-\text{OS}_3\text{H}$ | sulphatoethylsulphone |
| | $(\text{Fb}) -\text{SO}_2-\text{CH}=\text{CH}_2$ | vinylsulphone |
| IV. | $(\text{Fb}) -\text{NH}-\text{CO}-\text{CBr}=\text{CH}_2$ | α -bromoacrylamide |
| V. | $(\text{Fb}) -\text{NR}-$  | trichloropyrimidine |
| VI. | $(\text{Fb}) -\text{NR}-$  | fluorochloropyrimidine |
| VII. | $(\text{Fb}) -\text{NR}-$  | methylfluorochloropyrimidine |
| VIII. | $(\text{Fb}) -\text{NR}-$  | methyltrichloromethylpyrimidine |
| IX. | $(\text{Fb}) -\text{NR}-\text{CO}-$  | dichloroquinoxalln |
| X. | $(\text{Fb}) -\text{NR}-$  $\text{NH}-\text{X}-\text{NH}$  $\text{NR}-$ (Fb)
$-\text{NHR}$ | dis-monochlorotriazine |
| XI. | $(\text{Fb}) -\text{NR}-$  | monofluorotriazine |
| XII. | $(\text{Fb}) -\text{NH}-$  | triazine-nictinic acid |
| XIII. | $(\text{Fb}) -\text{NH}-\text{CO}-$  | dichloropyrimidine carbonamide |
| XIV. | $(\text{Fb}) -\text{NR}-$  $-\text{NH}-$  | monochlorotriazine
sulphatoethylsulphone |

Reaming: Further plying of a two-ply yarn with a singles yarn. Reaming is not the same as plying three singles yarns in one operation.

Rebayn: Medieval English name for fabrics woven with gold patterns over blue silk ground, made at Cologne, Germany.

Rebozo: (1) Shawl, made of knitted silk or wool, worn by Mexican women; (2) Fulled woollen fabric, usually black, navy or dark green, used for skirts by the natives in Colombia.

Reclaimed cotton: (effilochées), cotton reclaimed from cotton rags.

Reclaimed wool: Produced from various types of wool products, waste fibres from the spinning mill, weaving mill, knitting mill and hosiery mill as well as (Rags) domestic waste fabrics, waste new fabric from the weaving mill or tailoring shop, etc. Types of woollen spinning yarn recovered by mechanical processing (carbonizing and dyeing, etc.) are classified as follows: Grade I = shoddy; Grade II = Tibet; Grade III = Mungo; Grade IV = alpaca.

Recovered wool: (reused wool). Recovered wool is similar to Skin wool but is produced from tanned pelt wastes and wool rags. The quality and extent of damage of recovered wool varies widely (inferior to fleece wool) and is dependent on the amount of wear and tear and degree of tanning. The material is therefore generally unsorted.

Reconstituted fibres: Fibres made from recovered waste polymer or blends of virgin polymer and recovered waste polymer.

Recouvees: Stout French linen of natural reddish colour.

Recoverable elongation of rope: Elongation which may be reclaimed following a period of rope relaxation after the rope was cyclic tensioned.

Recovered wool: Obtained by converting woollen rags into fibres by tearing them up and reworking them again. Shoddy and mungo are recovered wool.

Rectified spirit: A constant-boiling mixture of ethanol and water that contains about 6% water; no more water can be removed by further distillation. It is used as an industrial solvent.

Recupra process: Used for the recovery of polyacrylate finishes. BASF/Benninger process (Recycling) facilitates recovery of 60–80% of the coated finish. The goods to be desized no longer pass through the desizing bath. Application is by small counter-rotations in three stages and squeezed out and concentrated in a heavy press. The remaining desizing can be combined with the next finishing stage.

Recure: (recurring permanent press process). It is a variant of the pre-cure process (Permanent press process). Fully cured synthetic resin coatings

(aminoplasts) are partially hydrolysed by subjecting them to particular cycles of steam ironing (“re-crosslinking” the cotton component) and curing them in the new shape simultaneously.

Red dye, Vegetable: Following plants dye red shade. Birch. ‘*Betula alba*’. Fresh inner bark. Bed-straw. ‘*Gallium boreale*’. Roots. Common Sorrel. ‘*Rumex acetosa*’. Roots, Dyer’s Woodruff. ‘*Asperula tinctoria*’. Roots. Evergreen Alkanet. ‘*Anchusa sempervirens*’. Gromwell. ‘*Lithospermum arvense*’. Lady’s Bedstraw. ‘*Gallium verum*’. Roots. Marsh Potentil. ‘*Potentilla Comarum*’. Roots. Potentil. ‘*Potentilla Tormentilla*’. Roots. Wild Madder. ‘*Rubia peregrina*’.

Red mordant: (red liquor) Aluminium acetate.

Red Tape: Cotton tape of red colour used in some government and law offices to tie bundles of papers with.

Red prussiate of potash: Potassium hexacyanoferrate (III).

Redingote: Waisted coat with full skirts or a back vent usually double breasted; riding coat.

Redox: Relating to the process of oxidation and reduction, which are intimately connected in that during oxidation by chemical agents the oxidizing agent itself becomes reduced, and vice versa. Thus an oxidation process is always accompanied by a reduction process. In electrochemical processes this is equally true, oxidation taking place at the anode and reduction at the cathode. These systems are often called *redox systems*, particularly when the interest centers on both compounds. Oxidizing and reducing power is indicated quantitatively by the *redox potential* or standard electrode potential, E_s . Redox potentials are normally expressed as reduction potentials. They are obtained by electrochemical measurements and the values are referred to the H^+/H_2 couple for which E_s is set equal to zero. Thus increasingly negative potentials indicate increasing ease of oxidation or difficulty of reduction. Thus in a redox reaction the half reaction with the most positive value of E_s is the reduction half and the half reaction with the least value of E_s (or most highly negative) becomes the oxidation half.

Redox potential: (expressed as r_H). “Redox” is an abbreviation of the term reduction-oxidation. The redox potential scale is used for classifying reduction and oxidation processes in solution, the electrical voltage (potential) in question being measured in volts or millivolts against a reference electrode (Standard electrode potential).

Reducing agents: A chemist’s term for any chemical that causes gain of electrons by another chemical with which it reacts; the reducing agent is itself

oxidized (see oxidizing agent) in the process. Many reducing agents are used in dyeing processes. They include thiourea dioxide, sodium bisulfite, sodium formaldehyde sulfoxylate, sodium hydrosulfite and others. They are often used in discharge and stripping processes, and are used for converting insoluble vat or sulfur dyes to the soluble form. Solid-chemical reducing agents are often flammable. See **Reduction**.

Reduction: The gain of electrons by atoms, molecules, ions, etc. It often involves the loss of oxygen from a compound, or addition of hydrogen. Reduction can be effected chemically, i.e. by the use of reducing agents (electron donors), or electrically, in which case the reduction process occurs at the cathode. See also **Redox**.

Reduction clearing: Removal of disperse dye on the surface of fabric by use of a reducing agent. Fine particles of disperse dye often remain on the surface of dyed fabric. These particles can cause wash fastness problems, yet are hard to fully remove by washing alone. For polyester, a mixture of about 2 grams per litre each of sodium hydrosulfite and sodium carbonate is used at about 70 degrees Celsius for about 20 minutes. Dye inside the fibre is not effected by this treatment.

Reduction thickener (blend), addition of a thickener with reduced chemical activity for a printing paste (stock colour or full colour) to obtain lighter printing inks, for example, 1 : 9 = 1 part printing paste + 9 parts thickener (1/9).

Reductive bleaching: Bleaching with Reducing agents, predominantly for animal fibres. With other fibres, possibly used in a second bleach bath in combination with oxidising bleaches (Bleaching).

Reductive discharges: Discharges (Discharge printing) based on a reduction effect where the dyes in question, (a) are split up into colourless soluble compounds, i.e. fully destroyed and have to be removed by subsequent washing (for example, direct, acid and mordant dyes or naphthols) or, (b) because of their solubility, particularly in alkaline solution, are more or less removed before the fibre is re-oxidised, i.e. are not destroyed (for example, indigoids and anthraquinoid dyes, such as indigo and vat dyes as well as cationic dyes as derivatives of tri-phenyl methane).

Redyeing: Dye packages may have to be dyed a second time because of faults or stock packages may have to be redyed as they cannot be sold due to their particular shade. In both cases, stripping of dyeings is usually necessary first.

Reed: The warp threads in a loom also go through a reed, a device consisting of several wires closely set between two slates of baulks that may serve any or

all of the following purposes separating the warp threads, guiding the shuttle or rapier (if applicable) and beating up the weft. Reeds are sized by length and by the number of spaces—called dents—per inch (i.e., 4, 5, 6, 8, 10, 12, 15, 18 etc.). The reed is placed in the beater and acts to press the weft into the cloth as well as space the warp.

Reed holders: are wooden supports that keep the reed at a vertical position so it can be sleyed at a table rather than on the loom.

Reed hook: A reed hook or sley hook is a flat piece of metal, wood, or plastic with smooth curves at both ends for pulling threads through the dents of the reed.

Reed mark: A warp-way crack or disturbance of the structure in a woven fabric continuous or at intervals, caused by a reed misdraw or a damaged or defective reed. See also **Reedy warp**.

Reed plan: Weaving technology term. The reed plan shows the arrangement of the warp thread in the reed dent.

Reed plate, in tufting machine: A flat comb-like plate with slots on one side spaced in accordance with the machine gauge.

Reedy: Flaw in the cloth, caused by several warp ends running through one dent.

Reedy warp: See **Reed mark**.

Reefer: A short round coat or jacket.

Reel: (1) A revolving frame on which yarn is wound to form hanks or skeins. (2) The frame on which silk is wound from the cocoon. (3) A linen yarn measure of 72,000 yards. (4) The large wheel in a horizontal warper onto which the warp sections are wound in the indirect system of warping. (5) A spool of large capacity used to wind yarn or wire.

Reeled silk: Silk winched from the cocoons of the silk worm as Grège derived from almost continuous elemental fibres.

Reeling: A preparatory process in the manufacture of silk, consisting in placing the unbroken cocoons in hot water and unwinding the single filaments several of which are joined side by side, without any twist and kept together by the natural gum of the silk.

Re-embroidered lace: A flat lace that has been reworked with another intricate design using a variety of threads. An elaborate and expensive fabric, due to the two operations involved.

REF Fibres: (REF = Roll Embossed Fibre), made from Tape yarns by embossing the yarns with longitudinally-grooved profile rollers followed by

width stretching, where the areas on the fabric that have been thinned by the embossing process tear open, forming multi-filaments (elemental filaments with a high degree of uniformity and high strength).

Reference sample: An order sample for the Colour matching of dyed/printed samples.

Reference temperature: A fixed point on a scale of temperatures, for example, the melting point of ice $\pm 0^{\circ}\text{C}$ and the boiling point of water $+ 100^{\circ}\text{C}$ at ntp (Temperature).

Reference standard: See **Reference sample**.

Refin: French term for the best grades of wools of any certain class.

Reflectance: The ratio of the intensity of reflected radiant flux to that of incident flux. In popular usage, it is considered the ratio of the intensity of reflected radiant energy to that reflected from a defined reference standard.

Reflectance curve: The point associations (from a spectral photometer or automatic recording) of the percentage Reflectance plotted against the wavelength in a coordinate system produces the reflectance curve. In the visible range (400–700 nm), these characterise the ratio of reflected light to incident light, thereby yielding calorimetric information on the physical parameters of each dye or dyeing.

Reflectance factor: The ratio of the light reflected from the specimen to the light reflected from the perfect reflecting diffuser under the same geometric and spectral conditions of measurement.

Reflectance, specular: See **Specular reflectance**.

Reflectance, total: See **Total reflectance**.

Reflection: Component of incident light meeting a surface which is neither subject to Absorption nor Transmission (Reflectance). In the case of reflection, the incident energy is only briefly absorbed by the individual atoms in order to be reflected again as potential energy.

Reflection spectrophotometers: In reflection spectrophotometers, the reflection of light by the sample is measured at each wavelength relative to that of a white standard such as a plate coated with MgO or BaSO₄. These standards give almost 100% diffuse reflection (light rays reflected in all directions) between 380 and 750 nm. They are, however, rather fragile and often a working standard such as a ceramic tile of known reflectance is used. Calibration of the instrument with a white standard tile allows calculation of the reflectance of the sample relative to that of a perfect diffuse reflector having 100% reflection of the incident light at all wavelengths.

Refleuret: French term for best grade wool.

Reformdress: Loose, freely draping dress, worn without a croset.

Reform weave: A weave which results in warp-reinforced fabric with main warp.

Refraction: The difference from a straight path undergone by a light ray in passing obliquely from one medium (as air) into another (as glass) in which its velocity is different.

Refraction Index: The standard scale used for measuring refraction is called the refractive index (refractive exponent): quotient of the sine of the angle of incidence and the sine of the angle of refraction:

$$\sin a/\sin b = n = \text{constant}$$

The refractive index of air (in comparison to vacuum) is practically equal to nD 1; as, for example, the refractive index of solutions varies with concentration, this parameter can be used to determine the concentration. The refractive index is also utilized in fibre microscopy in the so-called immersion system where immersion fluids are used with a refractive index matched to that of the test fibre.

Refraction of light: (refraction), guiding or changing the direction of light as it passes through the boundary between different media such as light/water. While doing so, the long wavelength light (red) is not so strongly refracted as the short-wave light (violet/ blue).

Refractive index: Also called Index of refraction. The ratio of velocity of radiation (as light) in the first of the two media to its velocity in the second as it passes from one into the other.

Refractory fibre: Oxide or non-oxide, amorphous or crystalline, manufactured fibre generally used for applications at temperatures greater than 1063°C in both oxidizing and nonoxidizing atmospheres, i.e., Al₂O₃, ZrO₂, Al₂O₃ SiO₂.

Refractory organics, in waste water treatment: These organics tend to resist conventional methods of waste water treatment. Typical examples include surfactants, phenols and agricultural pesticides.

Refrigeration process: A wool scouring process. In this method raw wool is first exposed to low temperature environment of about -30~ which freezes the wax and vegetable matter and thus becomes hard and brittle. In the second stage these impurities are removed from the fibre by some mechanical means.

Regain: Average normal moisture which the fibre should contain, as for instance: cotton, raw or yarn, 8% per cent; linen, 12 per cent; carded wool and

wool waste, 18.4 per cent; wool yarn, 17 per cent; worsted yarn, 18.4 per cent; jute, 13% per cent; silk, 11 percent; noil, 14 per cent.

Regain standard: See **Regain**.

Regatta: (1) A striped or checked cotton fabric, made in England with a two and one, warp face twill and well starched filling; used for aprons, children's dresses, etc; (2) Woollen fabric, made with alternating gray and coloured or blue and white stripes of twill weave.

Regatta Stripes: Good quality, equal blue and white striped calico used in England as dress goods.

Regency Point: A Bedfordshire bobbin lace, made during the 19th century, with a thick edge, originally with tape design on reseau ground, later with plaited ground and raised patterns similar to the Maltese laces.

Regenerated cellulose: A material which begins as cellulose but at some stage in the chemical processing takes the form of another chemical compound, then appears again in its completed state as cellulose. Viscose and cuprammonium rayons are regenerated cellulose.

Regenerated cellulose: "Recovered cellulose" which, unlike native cellulose (cotton) has a lower degree of polymerisation (and correspondingly different characteristic properties). Identical to Cellulosic fibres, regenerated (viscose, acetate and cupro fibres).

Regenerated fibres: These are fibres created by modified natural fibres. The cellulose regenerated fibres include rayon and acetate. The protein-regenerated vegetable fibres include soybean (soylon), peanut (ardil), and corn (vicara). The protein-regenerated animal fibres include casein (aralac), gelatin, and albumin. See Cellulosic fibres, regenerated; Man-made protein fibres.

Regenerated protein fibre: See **Man-made protein fibres**.

Register marks (Printing): In roller printing, the pattern being reproduced is broken up into a large number of dots using a reproduction camera with a traverse or shading screen, so that the dots are graded in size according to the shades.

Regrettas: Narrow cotton goods, mostly in narrow blue and white stripes and blue filling; used in the Philippine.

Regular Twill: Trade name for 45 degree twill weave, without any fancy figure.

Regulators for peroxide bleaching: Peroxide decomposition can be influenced by the use of appropriate bleaching agents, known as regulators. Regulators mean substances or substance compounds that are able to preserve the

perhydroxy anions (HO^{-2}) responsible for the bleaching effect for as long as possible, and largely suppress decomposition. The essential point of this is to prevent uncontrolled peroxide decomposition during the bleaching process, by means of regulators acting on the reaction sequence.

Reinforced Hosiery: Reinforced Hosiery is knitted at the toe and heel in such a manner as to prevent unraveling of the fabric if the stitches wear out.

Reinforced seam, in sewn fabrics: The seam that includes an additional layer of material on the face or backside of the seam allowance.

Reinforcement fabrics: See **Geotextiles**.

REK: Russian fastness commission.

Related shades: Colours of similar tone in the same or different depths.

Relative humidity of air: The ratio of the pressure of water vapour present to the pressure of saturated water vapour at the same temperature.

Relative humidity: See **Relative humidity of air**.

Relative humidity: The ratio of the actual pressure of the water vapour in the atmosphere to the saturation pressure of water vapour at the same temperature. (The ratio is usually expressed as a percentage.)

Relative viscosity: Ratio of the viscosity of the polymer in solution to that of the solvent expressed as time of efflux of the solution divided by the time of efflux of the solvent at constant temperature.

Relative whiteness: Comparison of two whiteness.

Relaxation: The releasing of strains and stresses in textile materials.

Relaxation dimensional change: The dimensional change that occurs when a knitted fabric is immersed in water without agitation and the strains and tensions put to fibres, yarns, or fabrics during previous processing stages such as spinning, knitting and finishing are received.

Relaxation of elastic fibres: Before carrying out any further treatment, it is recommended to relax woven or knitted goods to obtain a uniform shrinkage and avoid stitch distortion or fabric deformation, creases or wrinkles. The fabric relaxation is a crucial step to allow good shrinkage and give excellent elasticity since the fabric width on looms is always bigger than the finished one (tensioned yarns on the loom). Many techniques are used but here are some of the most frequently used ones: table steaming, steaming carried out at the entry of the stenter, scouring carried out with hot solvents, relaxation in hot water with tensionless scouring; these techniques give poorer stabilisation results and do not provide permanent crease resistance to textiles and fabrics.

Relaxation shrinkage: A shrinkage induced by the relaxation of strains present in a textile. **Note:** Strains of a temporary nature can be relaxed to a varied degree, e.g. by steam pressing or by immersion in water. Relaxation shrinkage is the irreversible dimensional change accompanying the release of fibre strains imparted during manufacture which have been set by the combined effects of time, finishing treatments, and physical restraints within the structure.

Relaxed yarn: A yarn treated to reduce tension and produce more uniform shrinkage or torque. Relaxation produces more uniform dyeing characteristics in regular filament yarns of nylon or polyester.

Release point (Rp): Release Point (Rp) is defined as the surface tension of a detergent solution where oily soil just separates from fibre surfaces. This technique for quantifying soil release is based on thermodynamic considerations which state that the work of adhesion (the quantity $Y_{fo}-Y_{fd}$) must be overcome by the detergent for oily soil to separate from a solid surface. In a detergent solution, when the contact angle becomes 180 degrees and the oil just separates from the fibre, the interfacial tension between the oil/detergent will equal the work of adhesion. $Y_{od}=Y_{fo}-Y_{fd}$. The quantity Y_{od} is influenced by the adsorbed surfactant. Therefore surface tension of a bath where release just occurs is proportional to the work of adhesion between the oil and fibre surface.

Releasing slider, in Zipper: A slider with a mechanical means for loosening the slider on the chain.

Releasing stop, in Zipper: A device attached at or near the top of the stringer on the separable pin side which limits the travel of the slider at the open end of the chain under normal closing operations.

Relief engraving machine: See **Engraving**.

Relief printed effects: (three-dimensional printing). This does not refer to roller printing with relief rollers, which is widely known, but to the combination of chintz printing or Emboss printing with particles of crêpe prepared in caustic soda on cotton fabrics.

Relief valve: A pressure relief device actuated by inlet static pressure having a gradual lift generally proportional to the increase in pressure over the opening pressure.

Relustering Restoration of gloss finish. After treatment, particularly for modacrylic fibres, partly combined with the drying process.

Remafam dyeing machine: Continuous dyeing and drying plant for piece goods. Impregnation padder with 36% methanol and required additives,

contact-free in short IR heating duct until methanol reaches flash point, ignition in combustion chamber causing water to evaporate, combustion temperature 750°C, fabric temperature 45–70°C (never as high as 100°C if no dye setting), air cooled.

Remaflam process: Drying process developed by Hoechst and Brückner, in which methanol is used as an energy carrier (Methanol/Water flashpoint). Process for padding and drying textiles, in which textiles are soaked in a flammable liquid (e.g. methanol). At the next stage, combustion of the liquid takes place, causing the water to evaporate. Remaflam drying has an initial speed of 10 m/min; after approx. 5 min the speed is 70% of the ultimate speed (which is reached after approx. 20–30 min). The average drying speed is therefore dependent on the length of the cloth run.

Remazol: A family of vinyl sulfone reactive dyes; tradename of Dystar of Germany.

Rembrandt Rib: Women's hosiery made with lengthwise rows of five drop stitches alternating with inch-wide strips of plain knitting.

Renaissance lace: Motifs joined by a variety of stitches.

Renforce: Also known as dense plain weave cotton fabric; medium-fine cotton quality, finer than cretonne. Available as raw material, bleached, dyed and printed. See Plain weave cotton fabric. Used for dresses, blouses, bedsheet etc.



Rengue: Fine cloth made of pineapple fibre In the Philippines.

Renter: To restore damaged tapestry through inserting new warp.

Rep (p), Repp: Usually a heavy or medium fabric with very pronounced rib. It differs from poplin in that only every second pick is heavy. For instance, a rep for shirting may have a thread count of 100 x 40 with 40s warp and alternating picks of 40s and 10s in the filling. Rep for upho; stery are much coarser. A characteristic construction for these reps is 80 x 20 with 2/30s warp and alternating picks of 15s and 4s. It is made from a variety of fibres,

including cotton, viscose and blends of fibres and occasionally from worsted yarn. It is stiff and unyielding but also very hard wearing. Used for curtains, loose covers, bedspreads etc.

Rep Stitch: See **Persian cross-stitch**.

Repeat: The smallest size of a pattern that shows the full pattern.

Repeat artists: Designers who take the designs, put these into a size, and repeat appropriate to the intended end-use.

Repeat for printing: The smallest size of a printing design that shows full design. One or more of this repeat is engraved on to a screen and the printing is done. During screen making each colour from the repeat is engraved on different screens.

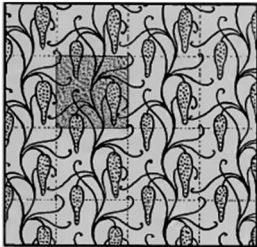

A design with repeats marked



Repeats

Repeat size: The distance covered by a single unit of a pattern that is duplicated over and over, measured along the length of a fabric.

Repellency: The ability to resist wetting and staining by oils, water, soils, and other materials.

Repellent (repellate), substances with specific repellent, but non-damaging, properties, such as Insect repellent finishes.

Repetition, in garment designing: involves the use of patterning to achieve timed movement and visual 'beat'. This repetition may be a clear repetition of elements in a composition, or it may be a more subtle kind of repetition. See **Rhythm**.

Repp or Rep: Wool, worsted, silk, rayon, wool ottoman, cotton or a blend. Crosswise rib. Has a pronounced narrow cylindrical rib in the filling direction - less distinct than bengaline; more distinct than poplin. Sometimes a very distinct rib is alternated with a small rib. It is similar to poplin but heavier in cotton. Can be dyed, printed, or white. Frays badly. Difficult to press (may flatten rib). Uses: Heavy suits, and coats for men's and boy's wear, and also for some women. Also used for upholstery and drapery.

Reprocessed wool: Woollen fibres obtained from existing knitted, or woven garments. Now this fabric is very rare, as it is difficult and very expensive to reprocess blends.

Reproducibility Capacity to repeat the properties defined in the specification, such as colour shade. The evenness of dyeing is assessed on the padder.

Repousse Lace: The design consists mostly of dots, also of flowers and leaves which are raised like blisters and are pushed in in the back.

Reps: (1) French drapery velvet made of cotton and wool; obsolete; (2) A French silk fabric, having organzine warp, the ribs are either warp or cross ribs.

Repp weave: See **Cannele weave**.

Re-reeling: Certain Chinese silks which are given a second reeling after the first one performed by unskilled native workers.

Rere: Fine, white bast fibres of th* *Cypholophus macrocephalus* in the Pacific Islands; used for clothing mats by the native.

Reseau: See **Net**.

Reserve dyeing: See **Dyeing**.

Reserving agent: Also called restraining agents; a dye bath auxiliary that is typically used to prevent one fibre in a blend from taking up dye intended for the other fibre, or to equalize the uptake. When blends are dyed, one fibre may be truly dyed while the other is stained (coloured, but with very poor fastness). Reserving agents can be used to significantly reduced the undesired staining. In blends such as woolnylon, reserving agents can act to reduce the dye uptake by the nylon, so that the nylon and wool ultimately are coloured similarly.

Reservoir fabric: e.g. Made from polyester, functions as re-dyeable dye carrier (typewriter ribbon principle) in the transfer dyeing unit.

Residue, for plumage: Quill pith, quill fragments, trash or foreign matter.

Residual colour difference (Or Residual colour deviation): The residual colour difference is the difference which results when the specimen and the type are both dyed in exactly the same colour strength. Even when the specimen and the type are dyed in one concentration only, the residual colour difference can be precisely computed colorimetrically because any colour strength difference can be computed with the aid of the Kubelka/Munk relation and taken into account. The total residual colour difference can be divided into a hue and a chroma portion. Thus by means of colorimetry an exact coloristic evaluation of the colour strength, hue and chroma is possible based on only one specimen and type dyeing in each case.

Residual elongation of rope: Elongation after cyclic tensioning the rope to a specified force for a specified no. of cycles and allowing the rope to relax for a specified period of time.

Residual moisture content: Moisture content of fabric after the drying process. Pre-driers should be designed so that fabric moisture after drying is maintained at the same level so that, among other reasons, dye migration at the fibre surface is kept constant throughout the dyeing process.

Residual print paste: (print paste returns). Unused print paste left on the print machinery or printing table because a greater quantity than necessary for the meterage was applied for safety reasons.

Residual shrinkage: The potential shrinkage that remains in a fibre, yarn or fabric after treatment designed to reduce or eliminate shrinkage. *Note:* The expression is commonly used with reference to heat-shrinkage properties of synthetic polymer fibre after it has been heat-set.

Residual torsion: Revolutions made by a specified length of cord when one end is held in a flexed position and the other allowed to turn freely.

Resilience: That property of a material by virtue of which it is able to do work against restraining forces during return from a deformed state.

Resiliency: The ability of a fabric to spring back to its original shape after being twisted, crushed, wrinkled, or distorted in any way.

Resin: (1) A general term for solid or semi-solid natural organic substances, usually of vegetable origin and amorphous and yellowish to brown, transparent or translucent, and soluble in alcohol or ether but not in water. (2) Any of a large number of manufactured products made by polymerization or other chemical processes and having the properties of natural resins.

Resin antifelting finish: Antifelting finish of wool on the basis of synthetic resins. See **Hercosett process**.

Resin bonded batting: A textile filling material that is stabilized by spraying it with an acrylic, polyvinyl acetate, or other suitable resin emulsion after which the batting is dried and cured.

Resin dyeing process: Dyeing and finishing combination processes.

Resin finish: See **Resin finishing**.

Resin finishing: General finishing that gives each fibre additional properties depending on requirements (soil-release, moth repellent, antifelting, creasing resistance). Finishing that has a significant practical value, and causes permanent improvement in wear resistance (wash and dry-cleaning resistant), particularly shrinkage stability and crease recovery, of textiles

made out of cellulose or cellulose compounds, by means of intercalation and/or modification of the cellulose (Resin finishing processes) with certain finishing products (Resin finishing agents). Also known as: Permanent press process, Wash and wear finishing, Anti-crease finish, Non-shrink finish, Swelling resistant finish, Easy-care finishes, No iron, Non-iron, durable press, minimum-iron, and rapid-iron finishes.

Resin finishing agents: Resin finishing agents are usually water-soluble, low-molecular, polyfunctional products that, in the presence of Catalysts for resin finishing, which work in an acidic or alkaline environment, are converted to either water-soluble, high-molecular compounds that are resistant to washing and dry-cleaning (Self crosslinking resins), and/or crosslink with the cellulose fibres. See **Reactive resin**.

Resin finishing catalysts: Chemicals which enhances the crosslinking of the resin finishing agents.

Resin finishing of knitted goods: In case of knitted goods, good dimensional stability and good sewability are the crucial factors in resin finishing. N-methylol compounds of ethylene and hydroxyethylene urea (60–90 g/l, 45%) and melamine formaldehyde compounds, usually partially etherized and often as additives with a buffer function, are often used as resin finishing agents for achieving dimensional stability.

Resin finishing process: Process techniques in Resin finishing. Application of Resin finishing agents under specified crosslinking conditions. Largely responsible for defining intended finishing effects. Major processes: Dry cross-linking, moist crosslinking, wet crosslinking. Used alone, they represent multiphase crosslinking processes. When selecting cross linkers and catalysts for a process, there is a range of combination possibilities from a technical point of view. In industrial production there are two basic condensation types – high temperature condensation and cold dwell condensation. In general, condensation in resin finishing is a chemical reaction between cross linkers and cellulose, usually causing water release.

Resin formers: Chemicals which forms resin by any process like condensation etc.

Resin migration: Migration of pre-condensates and catalysts within the yarn and between thread systems during the drying process in resin finishing. The main effect of this is worsening of abrasion resistance in crosslinked cotton fabrics.

Resin resist printing: See **Wax resists**.

Resin-treated: Usually, a term descriptive of a textile material that has received an external resin application for stiffening or an internal fibre

treatment (especially of cellulose) to give wrinkle resistance or permanent press characteristics.

Resist: In dyeing (and some other processes), something applied to fabric to prevent dye from colouring it. Resists such as waxes used in batik simply prevent dye from gaining access to the fibre. Tie-dyeing and shibori employ what amount to mechanical resist methods to limit dye access. Chemical resists allow the dye to gain physical access to the fibre, but prevent fixation of the dye to the fibre. These include sulfites such as sodium bisulfite, as a resist for vinyl sulfone dyes, citric acid as a resist for many reactive dyes for cellulosic fibres, and sulphamic acid as a resist for acid dyes on wool.

Resist dyeing: See **Dyeing**. The principle of this process of dyeing follows: The fabric is first printed with some chemical which will resist to the subsequently applied dye on the places where it was applied.

Resist printing: (resists, reserve print). There are two different types, pre-printed and over-printed resists, depending on whether the resist print paste was applied before or after preparation of the fabric with dye solution. In both cases, the dyeing of printed areas is prevented. The most suitable context for application is in conjunction with non-dischargeable dyes. There are mechanical resists, chemical resists, and chemical-mechanical resists.

Resist salt: An oxidizing agent added to dye baths or print pastes to prevent *reduction* damage to dyes. Under some conditions, especially where air is excluded, such as in steam fixation of dye, some of the dye may be decomposed by reduction (often the fibre itself acting as the reducing agent). Resist salts, such as sodium m-nitrobenzene sulfonate, generally used in alkaline conditions, or sodium chlorate, generally used in acid conditions, may be added to prevent this. Resist salts are also sometimes applied to fabric before printing with discharge pastes to protect the ground colour dye and/or improve the sharpness of edges of the discharge. This term is a bit misleading: don't confuse resist salts with chemicals used to keep dye from fixing to the fibre.

Resistance to creasing: Scale for measuring the resistance of textiles to Creasing. See **Crease resistance**.

Resistance to deformation: If an external force acts on a textile, it will be stretched or compressed; the usual measure for resistance to deformation is the modulus of elasticity (Tensile elasticity).

Resistance to slippage, in seam testing: The force required to separate the parts of a standard seam by a specified amount.

Resistance to tear propagation: Required strength when Tensile force is applied to the bearing width for sudden tear propagation of a fabric section from an initial cut. There are various different methods of testing this.

Resistance to yarn slippage: The force required to separate the parts of a standard seam by a specified amount.

Resistance to yarn slippage, at the seam: The force required to displace one or more yarns in a fabric from the original position, causing differences in alignment, or spacing, or both.

Resolution: Optical: interval between two points of the object (specimen), so that they can still be distinguished as separate entities under the microscope, for instance. Calculated by dividing the wavelength of light used for illumination (in the visible spectrum resolution limit approx. 0.4 mm) by the selected numerical aperture (formula for centrally-positioned illumination, almost double the resolution for angled light).

Resorcinol: (metadioxy benzene), $C_6H_4(OH)_2$; molecular weight 110; density 1.283; colourless crystals, slightly sweet tasting, water-soluble; also soluble in alcohol, ether, glycerol; melting point 110/111°C. Gives violet dyeing with iron chloride solution. Use: solvent (phenol considered) for cationic, united chrome dyes and tannic paints; for the fixation of cationic dyes on acetate; saponification of acetate; antiseptic (finishing effectiveness practically the same as phenol).

Resorption: The process by which a material that has given material by desorption takes up some more of the material given up.

Rest position, in knitting: The needle is in rest position with the needle positioned outside the cam. The sinker moves towards the machine centre.

Restoration: Action directed towards returning the condition of an object to its original state.

Restraint systems: An end use for textile fibres; restraint systems are devices such as air bags, seat belts, and shoulder harnesses for passenger protection in automobile, trucks, airplanes, etc.

Resultant linear density: The actual linear density of a plied (folded or cabled) yarn.

Resultant yarn number: The yarn number based on observed mass per unit length of a plied yarn, or a yarn whose number has been changed by processing such as twisting or bulking.

Retainer Pin, in Zipper: A tubelike element, similar to the separable pin, attached over the bead at the bottom end of the stringer opposite to the separable pin and that is designed to hold the fixed retainer position.

Retainer, fixed, in Zipper: See **Fixed retainer, in Zipper.**

Retainer, movable, in Zipper: see **Movable retainer, in Zipper**

Retainer pin, in zippers: A tube-like element, similar to the separable pin, attached over the bead at the bottom end of the stringer opposite to the separable pin and that is designed to hold the fixed retainer in position.

Retail: The sale of goods in small quantities to consumers.

Retainer, in designing: The fee paid in advance to ensure the services of a designer.

Retarder: A chemical added to a dye bath to reduce the rate at which dye attaches to the fibre; also called leveling agents A retarder may be required to prevent a dye from attaching to fibres so quickly that it would be very difficult to achieve level dyeing. Retarders are often used with acid dyes. They may work by quickly attaching to the fibre thereby temporarily keeping the dye from attaching, or by quickly attaching to the dye, temporarily keeping the fibre from attaching to the dye. Simple chemicals such as sodium sulphate may act as retarders for some dyes in some conditions. There are many retarders on the market that are proprietary mixtures of chemicals, often formulated to be companions for specific dye families. Reserving agents can be thought of as a special class of retarder. The availability to art dyers of retarders is limited.

Retarding: Slowing down, decelerating, braking; e.g. the dye uptake speed, which occurs in all dyes involved in the sense of levelling, but which is also capable of having a selective effect on certain dyes and would at least severely disrupt the levelling of such dye combinations.

Retarding agent: (retention agent), is used to prevent staining of a fibre type when dyeing textile blends. Retarding agents mostly have properties of mordants, which effect the textile fibre to be retarded before or during dyeing and consequently cause a change in the dye affinity (Mordanting).

Reticella lace: A very rarely type of needlepoint lace. It was a combination of drawn-thread lace work and cut work.

Retouching: Removal of blank, yellowed, colourless fabric areas or those altered in colour, caused by intensive Stain removal on non-colorfast parts or by concentrated chemicals, by possible careless stain removal or by the effect of perspiration (armpit areas), etc.

Retouching inks: Distinctions are made between liquid, paste and powdery retouching inks. Liquid retouching inks usually contain alcohol or oil soluble dyes. Retouching print pastes, for example, represent substances pulped with oleic acid, which are used directly or possibly diluted with benzene.

Retouching ink powder (Spotting agent) are chiefly so-called coloured Talcum varieties, mostly dust-free, for dusting and rubbing in, for refreshing dry-cleaned gloves, etc.

Retractive force: The tension generated in a textured yarn due to the formation of crimp in the filaments, under specified conditions of crimp development.

Retting (Flax): The subjection of crop or deseeded straw to chemical or Biological treatment to make fibre bundles more easily separable from the woody part of the stem Flax is described as water-retted, dew retted, or chemically retted etc. according to the process employed.

Retting, cold water: Cold water retting in running water is practiced in Belgium. Retting in stagnant water is the method usually employed in Ireland and Russia. The retting in stagnant water is more rapidly done, but there is danger of over-retting on account of the organic matter retained in the water which favours fermentation. In this case the fibre is weakened.

Retting, dew: In dew retting, the flax is spread on the field and exposed to the action of the weather for several weeks without any previous steeping. This method of retting is practiced in Germany and Russia.

Reused Wool: These are cleaned and shredded into fibres again, and then blended to make utility fabrics. See also “**shoddy**”.

Reutlinger matte: Network made from thin textile fibres for the separation of oil from waste water.

Reutlinger pill standard: (RPG). For the visual assessment of pill formation (Pilling behaviour, test methods). Contains 8 stages: RPG 1 = stippled, bobbly fibrous; RPG 8 = maximum pilled.

Reveche: Plain woven fabric, having a long nap, often curled, on one side. Later made in twilled or serge weave with a soft, spongy, full body.

Rever: A turned back lapel or cuff.

Reverse coloration method (RCM): The colour is applied onto the pre-padded, wet carpet material from the back side using dye liquor. It is also possible to carry out the dye liquor application repeatedly using different liquors.

Reverse osmosis: (hyperfiltration). Membrane separation process (Permeation), which is used for filtrating waste water. The reverse osmosis results from a pressure (of 40, 60, 80 bar) exerted by the concentrated solution on the semi-permeable membrane (polyamide 6.6- acetate sheets). The solvent (water) migrates from the concentrated solution through the membrane and is described as a permeate. The dissolved substances remain as a concentrate.

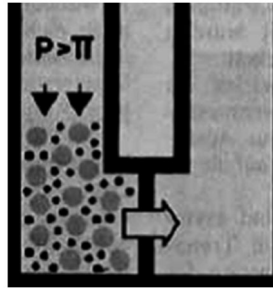

Principle of Reverse Osmosis

Reverse side: The side of a fabric opposite to effect side.

Reversed-tailing effect: Designation for end unevenness in padder dyeings, is caused by the fact that the fabric takes up more dye than corresponds to the absorbed liquid volume; dye concentrate increases in the colour box so that the end of the batch is darker than at the beginning. This process is called “osmosis”. After some time, this process reaches a state of equilibrium, at which a hydrostatic pressure is adjusted by the volume shift, which is described as the “osmotic” pressure. If a pressure is exerted on the concentrated solution after the state of equilibrium has been achieved, which is higher than the osmotic pressure ($p > \pi$), the process of osmosis can be reversed. Then solvent from the higher concentrated solution migrates into the diluted solution. The membrane retains the dissolved materials, which accumulate into a “concentrate” in the residual solution.

Reversed thread: Crossed, exchanged threads or thread pieces.

Reversed Twill: Twill weaves with the warp thread predominating on the face. Used in cotton and linen goods.

Reversible bonded fabric: A bonded structure in which two face fabrics are bonded together so that the two sides may be used interchangeable. There are limitations to the fabrics that may be used because of increased fabric stiffness resulting from bonding.

Reversible carpet: Jacquard patterned, thick Flat carpets made from two or more interwoven warp and weft systems. The design on the top appears colorwise to be a negative of the bottom (Kidderminster carpet, tree ply or double-faced carpet).

Reversible fabric: A fabric that can be made up and worn with the either side as the right side, the two side contrasting in either colour or design or both. The loth is thick, made from wool, acrylic, mohair, or blends. Used for coats, capes, duffle coats etc.

Reversible fabric: Double faced fabrics.

Reversible Imperial or Reversible Satin : A stout cotton fabric woven in 8-leaf satin weave, containing many picks in an inch, the weft forming the face on both sides. It is usually napped on one side.

Reversible twill: See **Reversed Twill.**

Reversing, stenter: Stenter with non-contact, air supported reversing of the material web (see Fig.). Entry and exit of the material length at the same end of the machine. Operating area corresponds to that of the Single-layer stenter.

Revolving spinning ring: A driven ring that rotates in the direction of the traveler on a ring spinning frame. Since both the ring and the yarn package turn when this ring system is used, productivity is increased.

Rewetting: Important part of the washing process, which runs in the opposite direction from previous Wetting, because a fibre, for example initially “wetted” by oil, is wetted by the aqueous detergent solution at the end of the washing process, after removal of the adhesion forces of the oil smuts (ball formation). This phenomenon is described as rewetting.

Rewetting agent: A surfactant which, after application and drying onto textiles, promotes rapid wetting on subsequent exposure to an aqueous solution. Used to improve the wetting of Ducks, tightly woven poplins and twills (0.25 – 0.5 g/l), and in sanforising to improve the moistening of the fabric before the entry into the rubber blanket zone See **Rewetting.**

Reworked Wool: Wool that has been previously used. Also called “*shoddy*” and “*mungo*”.

Reynolds number, *Re*: A dimensionless number that describes *pipe flow*.

$$Re = vd/\nu \quad Re = pvd/n$$

where V = mean velocity; d = diameter of pipe; ν = kinematic viscosity; p = dynamic viscosity; n = density of the liquid.

RF Drying: See **Radio frequency drier.**

RF heating: (Radio frequency heating) The use of dielectric energy of frequencies 3-300 MHz for heating.

RF Value: See **Whiteness, degree of.**

RGB: The additive primaries red, green, and blue. See **Additive Primaries.**

RGB Colour measurement system: This so-called “international trichromatic RGB system” is based on the law that any four types of radiation can have a known relative light composition, but an unknown light intensity from any two

are independent from three types of radiation in the corresponding mixture. The following radiation components were selected for filters in this system:

R = red = 700.0 nm

G = green = 546.1 nm

B = blue = 435.8 nm.

RF value: (degree of wash whiteness) Whiteness, degree of.

rh: Redox potential.

Rhadames: Stout and lustrous silk or cotton mixed dress goods, made with fine diagonal twill and dyed in solid colours.

Rhe: The unit of fluidity; the reciprocal of the unit of viscosity (the poise).

Rheological properties: The properties of viscous substances including polymers that deal with deformation and flow. Includes viscosity and flow rate measurements.

Rheology: The study of the ways in which matter can flow. This topic is of particular interest in the study of polymers (Gk.: rheo = to flow), describes how a body is deformed by externally loaded forces. In the case of print pastes and coatings, for example, it concerns fluids, which are subject to ultimate shearing strains. The paste is made to flow by an applied shear force, i.e. the polymer molecules move past each other. The resistance to this forced irreversible volumetric change is called Viscosity. This is substantially influenced by the molecular weight and density of the particles. See **Rheopexy**; **Thixotropy**; **Viscoelasticity**.

Rheology in printing and coating: Laws of rheology play a crucial role both in printing and in coating as the basis for these textile finishing processes. The flow behaviour of the print pastes influences the print quality. In many cases empirical methods for the assessment of print paste consistency no longer fulfil the requirements in accordance with production safety and reproducibility. It is possible to record the parameters of a print paste which determine quality, viscosity and flow characteristics of printing thickeners and print pastes metrologically using rotary viscometers.

Rheology modifiers: Although viscosity is often treated as a constant, only a few materials such as water and some mineral oils possess a constant "Newtonian" viscosity. In most fluids, viscosity varies with shear stress or shear rate. To completely describe the rheology of a formulation, it is necessary to know how the formulation handles, pours, pumps, coats, penetrates and spreads. Therefore, the correct choice of a thickener or rheology modifier is an important one.

Rheometer: Device for measuring rheological properties, consisting of two coaxially arranged movable cylinders.

Rhinegraves: Wide men's coulette breeches, close fitting at the hips and tied under the knee; richly decorated with loops of ribbon.

Rhodes machine: An earlier loose cotton dyeing machine, it consists of a trough, divided into three compartments by two plates. Lower portions of these compartments and bottom of the middle compartments are perforated. Steam pipes are provided at the bottom of the trough. Loose cotton is loaded in the middle compartment and kept in position by another perforated plate at the top, where it is fixed after loading the cotton. Liquor is added to the side compartment and heated by the steam pipes and heated. The heated liquor is raised through the side compartments and enters the middle compartments and percolates through the cotton to the bottom of the middle compartments and this circulation continues and the dyeing takes place.

Rhythm crepe: The name given to a fabric with regularly spaced puckering. It is made from viscose and resembles Seersucker.

Rib: A usually straight raised cord in textiles, formed by threads which are heavier than the others either in the warp or in weft, formed also by grouping several warps through the same reed or passing more than one lmg through the same shed.

Rib fabrics: Collective name for all materials, which have a ribbed appearance. The ribs may be in a longitudinal or transverse direction (longitudinal or transverse rib), in which the latter predominates; even diagonally in exceptional cases (inclined rib).

Rib, Warp (in woven): A rib running across the width is obtained by high density of warp ends, when two or more weft picks are placed in each shed (fig)warp yarn is usually finer than the weft and covers the surface of the fabric hence the name warp rib. A rib appearance also can be obtained in plain weave by using coarse weft and fine warp yarns. E.g., Ottoman, rib.

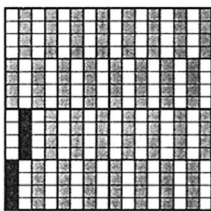

10 - 04 04 - 01 - 00

Pattern Draft

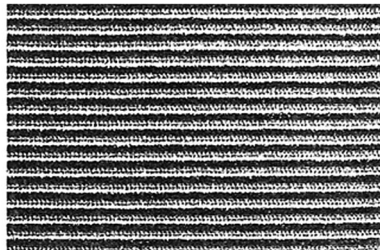

Warp rib

Rib, Weft (in woven): Rib running the length of the cloth are obtained with a high weft density by alternately raising or lowering two or more warp ends over and under the weft picks, with the same number of adjacent end doing the opposite. The high density of weft results in a lower weaving production rate, so these fabrics are not very common.

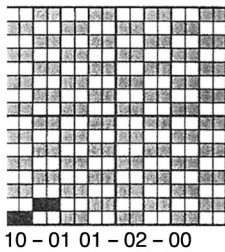

10 - 01 01 - 02 - 00

Pattern Draft

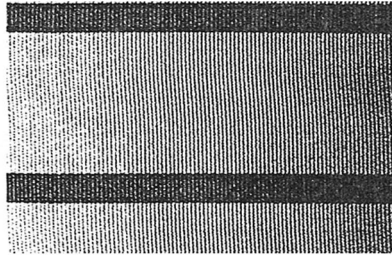

Weft rib

Rib fabric, Weft knitted: A fabric in which both back and face loops occur along the course but in which all the loops contained within any single wale are of the same sort i.e. back or face loops.

Rib Fabrics, 1×1, (English rib): A rib fabric in which single wales of face loops alternate with wales of back loops.

Rib fabric, 2×2 (Swiss rib): A rib fabric in which two adjacent wales of back loops in a series.

Rib gaiting: The needle arrangement on rib machines where the needles are arranged in such a way as to allow them to intermesh when raised.

Rib jacquard: In double jersey jacquard machines, the needles in the two needle beds (cylinder and dial) can be selected either to knit or miss. The pattern is created by selecting cylinder needles or knit or miss each coloured yarn in sequence. When the yarn is not knitting on the cylinder needles it is knitted by the dial needles to form the back of the fabric. The number of feeders required to complete one course depends on the number of colours in the design. These fabrics are used for pullovers, dresses and jackets.

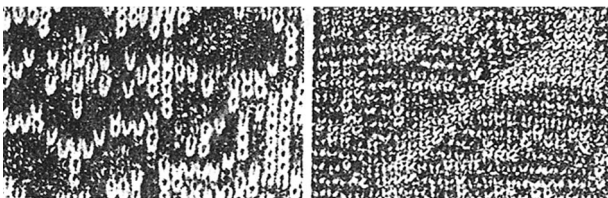

Rib jacquard face and back

Rib knit: A double-knit fabric in which the wales or vertical rows of stitches intermesh alternately on the face and the back. In other words, odd wales intermesh on one side of the cloth and even wales on the other. Ribknit fabrics of this type have good elasticity, especially in the width.

Rib knitted fabric: Rib fabrics are described as 1×1 , 2×2 , 6×3 rib, etc., and the most simple one is the 1×1 rib ($a \times b$; a represents the number of front stitches, b represents the number of back stitches). The 1×1 rib fabric is thicker, narrower, heavier, warmer and more elastic and expensive than plain knit fabric. It has higher width-wise recoverable stretch than plain knit fabric. It is also typically knitted using a finer yarn than a plain knit fabric. The yarn can be unravelled easily from the last course of the fabric. Balanced rib fabric such as 1×1 , 2×2 , 3×3 rib does not curl from the sides and the top/bottom.

Rib velvet: A rarely used name for corduroy.

Rib, Single or simple: These have more than one plain wale but only one rib wale, such as $2/1$, $3/1$, etc.

Ribs, broad: These have a number of adjacent rib as well as plain wales, for example, $6/3$ Derby Rib.

Ribbed spreader rollers: Spreader rolls used mainly for knitted fabrics on various processing machines for expanding work. They are provided with externally raised smooth spiral ribs running from the centre to left and to right. The fabric when runs over this rotating roller will be expanded width way due to the movement of the raised ribs outwards. More used to remove the curling of the open width knitted fabrics.



Ribbed spreader rollers

Ribbed weave: Variation of plain weave using fine and coarse weft yarn alternately to get a raised ribbed effect. The rib appearance is produced by using heavy yarns in the warp or filling direction, by grouping yarns in specific areas, or by having more number of yarns in warp than filling. Has a decorative appearance and feel, but not very durable.

Ribbing: A corded effect in a woven fabric that can be either lengthwise, crosswise, or diagonal.

Ribbon: Narrow fabric made in several widths and a variety of weaves and used as a trimming.

Ribbon, in textiles: A fine textured, narrow fabric which weighs less than 2.6 lb/100 yd per inch of width (approximately 15 oz/ sq. yd or 510 g/sq. m) and which is used primarily for trimming or decorative purposes.

Ribbon cutter: Textile or other stiff fabrics may be cut into ribbons using circular knives electrically heated wires or by laser beams and/or ultrasound.

Ribbon embroidered lace: A very elaborate fabric of lace background with matching narrow ribbon ruched and stotched in scroll designs on the right side of the lace. The ribbon is likely to be nylon or polyester to avoid crushing. The lace could be almost any fibre.

Ribbon weaving machines: The name ribbons identifies fabrics usually with a minimum width between 5 and 20 mm. They are produced today on particular multi-head machines with 2 to 12 heads, which are interchangeable at will and thus permit weaving several ribbons at the same time. The warp threads can be fed by beams or by a bobbin creel. The shed is formed by frames driven by cams (in case of small weft repeats) or by disks bearing linear cams composed of of glieder chains (these are small cams linked together to form closed rings) in case of larger weft repeats. When weaving figured ribbons, the threads are controlled by an electronic Jacquard machine.

Ribbon, Textile: A fine texture narrow fabric which weigh less than 2.6 lb./100 yards per inch width (app. 15 oz/yd² or 510 g/m²) and which is used primarily for trimming or decorative purposes.

Ribknit: See **Rib knit**.

Rice Braid: A braid consisting of a core yarn having alternately thick and thin places, entirely covered with a fine yarn wound around. It comes usually in white, but also in colour and is mostly of cotton; used for trimming and fancy work.

Rice Cloth: A plain woven cotton fabric made with hard spun warp and a fine novelty yarn, the latter having heavier places at close intervals. The cloth is somewhat similar to a fine ratine and comes in solid colour and in printed effect.

Rice net: Woven of coarse cotton thread stiffened by sizing and used as hat foundations.

Rice Stitch: Same as point de riz.

Richelieu: An open – work fabric made in imitation of hand embroidery if the same name. The designs are geometric, the embroidery may be in a yarn

which matches or contrasts with the backing fabric. The fibres used may be cotton, viscose, polyester, modal or a mixture of fibres. It is a medium weight crisp fabric. Used for blouses, dresses, children's dresses etc.

Richelieu Embroidery: White embroidery made with padded outlines in imitation of the Venise laces.

Richelieu Guipure: Cutwork with open patterns buttonholed along the edge and joined with bars.

Rickrack: Flat braid in zigzag formation. It is produced by applying different tensions to individual threads during manufacture.

Ricotti: Waste silk obtained from the inner smooth skin of the cocoon after reeling.

Ridgy beam: A beam of yarn on which the ends are not evenly distributed across the barrel, causing a profile of peaks (ridges) and valleys. A ridgy beam can give poor removal characteristics.

Ridgy cloth: See **Baggy Cloth**.

Rigging: The lengthways of folding a fabric.

Right handed twill: **Twill, Right handed.**

Right side: See **Face side**. Right side also called the public side, is the finished side of the fabric.

Rilatti: See **Bassini**.

Rimo: A fine, silky white cotton, grown in the valley of Senegal.

Ring, in hosiery: A narrow band around hosiery, visually different from the rest of the hose. Principal causes: Variations in yarn sizes, dye, absorption, or lustre.

Ring: The device that carries the traveler up and down the package in ring spinning. Also see Ring spinning and Revolving ring spinning.

Ring accumulator: A dwell device for processes which require a set time for continuous implementation. The floor space for a corresponding steamer is considerably larger for the same output.

Ring doubling: See **Ring twisting**.

Ring dyeing: Any dyeing in which the dye has not completely penetrated to the inside (centre) of the fibre. This can be seen in the fibre cross-section as is not completely dyed through. The dye is like a sheath on the outer periphery of the individual fibre; the fibre core is not stained or only stained to a slight degree. Depending on process, fibre type and dye, ring dyeing is a common

occurrence, particularly for densely packed, crystalline fibre materials, for large molecular dyes and for short-time dyeing processes. In extreme cases, ring dyeing results in visually higher yields, in poor colour fastness to rubbing and in use in whitish worn areas (cut-pile carpets).

Ring, in buttons: A split ring used to fasten a staple attached button to the substrate.

Ring in hosiery: A narrow, visually different horizontal band.

Ring opening polymerization: Formation of polymers by the opening of rings such as those of ethers or lactams. The formation of Nylon-6 from caprolactam is an example.

Ring spinning: A system of spinning using a ring-and-traveler takeup wherein the drafting of the roving and twisting and winding of the yarn onto the bobbin proceed simultaneously and continuously. Ring frames are suitable for spinning all counts up to 150's, and they usually give a stronger yarn and are more productive than mule spinning frames. The latest innovation in ring spinning involves the use of a revolving ring (Also see Revolving spinning ring) to increase productivity. Ring spinning equipment is also widely used to take-up manufactured filament yarns and insert producer-twist at extrusion.

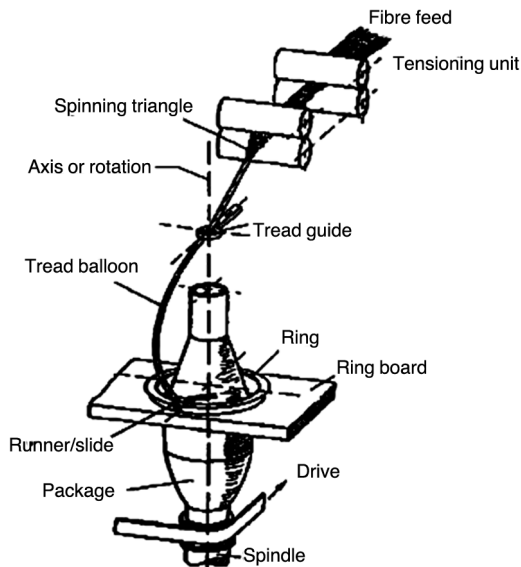

Ring spun: Yarn manufactured by the ring spinning method/machine.

Ring spun yarn: Yarn produced on a ring spinning frame.

Ring twisting: A system of producing folded yarn by twisting together two or more single yarns using ring and traveler as the twisting technique.

Ringer: (1) On a section beam, ringer is a term used for one or more filaments that have left the parent end; as the beam revolves, the filaments continue to unwind, wrapping around the beam (hence the word “ringer”). The severity of a ringer is dependent upon the number of filaments contained therein at the time the filaments break. (2) In slashing, the term ringer is often used when an end breaks on the slasher can, adheres to the can, and continues to wrap around it. This condition should not be confused with ringers on the section beam.

Ring-spinning: See **Ring spinning**.

Rinsing: Thinning, washing out, rinsing away of substances attached to the surface or inside fibres with water or solvent. In practice distinctions are made between the following:

- batch rinsing (151/kg water consumption) and rinsing in the overflow (201/kg water consumption),
- the counter current principle of rinsing in each individual wash compartment in continuous operation.

Rinzu: Silk satin in Japan.

Rio de Janeiro: Variety of raw cotton from Brazil.

Rip out: Pick out mark.

Rip-stop Nylon: A lightweight, wind resistant, and water resistant plain weave fabric. Large rib yarns stop tears without adding excess weight to active sportswear apparel and outdoor equipment such as sleeping bags and tents.

Ripening: Hydrolysis of cellulose acetate after acetylation to obtain the desired acetyl value.

This is generally accomplished by heat and agitation of the acid cellulose acetate solution under controlled conditions of time, temperature, and acidity. Rapid ripening is accomplished by using increased temperature for the reaction.

Ripout: See **Pick out mark**.

Ripped selvedge: See **Cut selvedge**.

Ripper selvedge: See **Ripped selvedge**.

Ripple cloth: An in expensive plain-weave fabric that has been slightly brushed on both sides and the forcibly shrunk to give it a wavy or rippled surface. Both treatments add warmth. The fabric may be made from wool.

But it is more likely to be acrylic or from cotton and therefore inflammable; in plain colours only. Used for dressing gowns and bed jackets.

Ripple shed: See **Wave shed**.

Rippler: The coarse comb used for removing seeds from flax fibre. The next step would be 'hackling'. The preceding step would be "**scrutching**".

Rippling: The process in flax production that removes the seed pods. The tool used is a 'ripler'. After this step of flax fibre preparation, the fibres are 'retted'.

Rise: The length of trouser from the top of the waistband at the fly opening, around the crotch, to the top of the back waistband at the center.

Riser: In textile fabric designing, a coloured or darkened square on the design paper which indicates that the warp end is over the filling pick at that point. The opposite of riser is sinker.

Rising roll batcher: 1. Batching device for open-width fabrics, operating at constant surface speed, with indirect drive. The batching roller lies on two driven rollers located horizontally adjacent to each other its axis is fitted laterally into vertical gliding rails. The roller rises in the rails as the diameter of the batching roller increases. 2. Roll batcher in which the yarn package lies on one or two rollers, of which at least one is driven at constant speed. The winding spindle rises in a guideway as yarn package diameter increases. (Batching drives).

R.M.M.: relative molecular mass; proper modern term instead of *molecular weight* 'Relative' is used because the mass is in proportion to one twelfth the mass as carbon-12.

Roasted starch: See **Dextrines**.

Rob Roy: A Highland tartan adapted and worn by Rob Roy. It is composed of alternate red and black stripes of equal width.

Robbings: Wool of greater length than noil, removed during the combing process.

Robe: Term for women's overdress, also called a manteau. See *manteau*.

Roberto rolls: Squeeze rollers, with a pressed steel core with porous natural/man-made fibre. 20–50% improvement in the squeezing effect compared with soft rubber roll. Action: firstly saturated with liquor, then squeezing as other squeeze rollers, at the same time the highly elastic, porous covering is compressed, and a portion of the moisture contained in the covering is pressed out in front of the nip (see Fig.). After the nip, the covering is opened again

and thereby additional drawing out of moisture from the fabric takes place using capillary action. – Manuf.: Roberto.

Robertson: A Highland tartan, composed as follows: * dark blue stripe; narrow red line; dark green stripe, as wide as the blue* ; red field, three times wider than the green stripe, split near each edge by a narrow blue stripe (spaced from the edge its own width), and also split in the center by a pair of fine, green lines; repeat, in reversed order, stripes mentioned above between two ‘. Robes 64 square twilled cotton fabric, printed in bright coloured patterns, and left unfinished; used for wrappers,, kimonos, robes, etc., now mostly for drapery purposes.

Robia voile: Robia is the trade name of wide variety of voile fabric made by Tootal. In 100% cotton, the voiles vary from satin stripes in various widths and colours to plain square-effect weave with self colour woven spots.

Rochelles: French linen used for bedding, shirts, etc.

Rocket package: A large version of a super cop used as means of supplying the weft to rapier weaving machine. It may be up to 800 mm in height and 75 mm in diameter.

Rod cast button: A button fabricated from a disc sliced or sawed from a cast rod of formulated styrene modified polyester resin.

Rod squeegee: A type of magnetic squeeze used in printing. There are different type of rods are used in practice. See **Doctor blade**.

Rodier: See **Double pique**.

Rolag: The cigar-shaped roll of carded fibre, losely rolled off of the hand cards, used as the fibre source when spinning woollen yarn.

Roll collar: A plain collar without peak or notch; a show collar.

Roll goods: Fabric rolled up on a core after it has been produced. It is described in terms of weight and width of the roll and length of the material on the roll.

Roll lapping: A condition in which groups of fibres attach themselves to the drafting rolls instead of following the normal path through the drafting system. These fibres cause the trailing fibres to wind around the rolls and to bread the end down completely. Cleaning of the rolls is required to remove the accumulated fibre.

Rolled end: See **Sticker**.

Rolled ends: (1) On a section beam, rolled ends are adjacent ends that do not unwind parallel to each other. Rolled ends can be caused by such factors as uneven tension, ridgy beams, and static. (2) The ends can also roll behind the

hook reed in slashing and can tangle with each other, resulting in broken ends and ends doubling.

Rolled hem: Rolled hem and whipped gathers are made with the wrong side of the material next the worker. Make a tiny roll of the edge towards the worker, using the left thumb and index finger, rolling an inch at a time (and no more) before hemming. Make fine, even stitches in the roll and goods. Keep the hem perfectly round, firm and not too large. This hem is adapted only to fine material and the edge across the warp is the more easily rolled.

Rolled seam-finish: A finish for the raw edges of the seam allowances of a plain seam, in which both raw edges are enclosed by rolling to one side and hand stitching close to the seam.

Rolled selvage: See **Curled selvedge**.

Rolled selvedge: See **Curled selvedge**.

Roller bed steamer: A steamer in which the fabric is carried in a relaxed state over a bed of individually driven rollers situated in the lower half of the steaming chamber.

Roller card: Generally, any type of card in which rollers do the carding. Usually this refers to a woollen card with a main cylinder and four to seven stripper rolls and worker rolls working in pairs.

Roller coating: Fusible polymers are heated and sealed in a roller until a film from the roller grinding mill capable of application is applied to the fabric to be coated (e.g. in PVC coatings of car covers). Coating pastes can generally be applied with the aid of a spreader, sieve or roller application systems. Roller application technology includes: (a) reverse roll coater; (b) smooth roller coaters; (c) grid roller application devices; (d) nip padding machines; (e) and immersion impregnation.

Roller conveyer steamer: A steamer in which the fabric is supported and carried in a relaxed state on an endless conveyer, made of stainless steel slate; which is driven by rollers at each end.

Roller engraving, electronic: Small bowls are cut with a sharp diamond chisel from the copper surface of the printing form in gravure printing cylinders. The diamond chisel is electronically controlled (electronic signals control position and depth of insertion of the chisel). The small bowls (which are pyramid shaped at the tip) have smooth walls due to the sharp cutting edges of the chisel, which has a positive effect on the transmission of the print paste to the printed goods. Chisel control signals are obtained through optical-electronic scanning of a black and white pattern (extract from a multicoloured design), which also contains developments as grey-scale values. See **Engraving**.

Roller grinding and polishing machine: This is a lathe-like device, in which the print roller rotates and is moved across a rotating disc. A water tank forms part of the polishing bench, in which the roller body is immersed by approx. 5–10 mm during the polishing process. The following are used as polishing materials: polishing stone, grinding stone, charcoal sized at approx. (5 × 12 × 25) cm³.

Roller hardness: The description of the hardness and/or softness for companies anywhere is in accordance with different scales for rubber or plastic rollers for finishing machines amongst other items, whereby confusion continually arises. It should be especially emphasised that the terms DVM softness and Shore hardness conflict with each other and are handled differently to some extent.

Roller mangle: A Mangle, which contains batch rolled piece goods in one and/or two magazines (double roller mangle).

Roller Printing: See **Printing**.

Roller printing: The print paste applicator is composed of the print paste tank (colour box) and the tank in the rotating applicator roller, which transmits the print paste onto the engraved roller. A doctor blade lying on top of the latter wipes off the surplus paste so that only the deep engravings still contain print paste and transmit this onto the material. The depth of the engraving is different. Shallow engraving up to 0.09 mm deep is sufficient for surface printing; this increases to 0.2 mm for good imprinting. The depth of the engraving is a criterion for the quantity of absorbed print paste and thereby a cost-determining factor. Shallow engravings give a rather smooth printing. They are pressed onto the cloth running between the printing cylinder and the engraved rollers by highly sprung spindles. During the running of the machine the print paste in the engraved grooves of the print roller is transferred on to the cloth as per the designed engraved.

Roller printing machines: Distinctions are made according to the type of roller printing area: (a) Gravure printing using Roller printing machines: almost exclusive mode of operation using gravure printing rollers, on which print paste is transferred from the print paste container (colour box) by a running roller (furnisher roller). Removal of the surplus print paste by a doctor blade moving to and fro at the side. Such print paste application devices are arranged around the printing cylinder corresponding to the number of print pastes. The fabric runs on a back grey (undercloth) with lappings and a continuous rubber cloth (printing blanket) between the elastic support and the engraved printing rollers. Joint drive of the printing rollers by a repeat wheel. (b) Relief roller printing (high pressure): of less importance. Printing

rollers with raised samples (print paste application using continuous felt tapes for example) are used. Still used partly for carpet and wallpaper printing. 3. Mosaic printing, e.g. Conversion print; Orbis printing.

Roller-conveyer steamer: See **Roller conveyer steamer**.

Rollers, Rolls: Rotatable cylindrical bodies. (a) For the guiding or transporting of cloth, either undriven or driven as Guide rollers; Draw rollers. Deflecting rollers may contain the roller pins sealed in a hollow cylinder as a simple equipment practice (b) For the processing of cloth: squeezing rollers, pressure or calender rollers (See **Calendar**), See **Printing rollers; Applicator rollers**.

Roller vat, roller beck: Basic form of all open width washing machines. Principle : Rectangular dyeing vats (approx. 1.1 m wide, 1.2 m deep, 3.5 m long) with guide roller system installed top and bottom, across which the piece good is carried in the zig zag by the liquor after passing an expander (speed of 15–100 m/min). 3–8 such dyeing vats are arranged in combination as required.

Rolling: The winding of finished fabric on tubes.

Rolling machine: For the rolling of textile fabrics during storage, further transport (and also for their protection). Particularly for voluminous textiles or those of such large width, such as carpet lengths for example, special rolling machines are required for the rolling of a polished technique into shape, which form regular yarn packages kind to material on corresponding carriers (tubes).

Roman Numerals In Chemical Names: Many ions can assume different electrical charges in different compounds. For example, iron can have a charge of +2 or +3. For example, in old use, iron chloride (FeCl) where the iron has a charge of +2, would be called 2 “ferrous chloride”, while FeCl_2 , where the iron has a charge of +3, would be called “ferric chloride”. In modern use, FeCl_2 would be called “iron (II) chloride” (read as iron two chloride) and FeCl_3 would be called “iron (III) 2 3 chloride” (read as iron three chloride). The roman numerals directly indicate the charge. In dyeing, this is most likely to be found in aluminum, chromium, copper, iron, tin and zinc compounds.

Rongkhim: Red shawl woven by Yimchunger Naga women of Arunachal Pradesh, India. Normally worn by warriors of great fame of their tribe, as the red is symbolic of the blood. If a man unworthy of the honour wears the shawl, it is believed that he will die of leprosy.

Rongolite C: BASF trade name for sodium formaldehyde sulfoxylate; sometimes seen spelled “Rongalite”.

Roosed: The process where fleece is plucked off of Shetland sheep during the spring. This works with Shetland fleece as the sheep produce a weak spot earlier in the season. Sometimes called roeing.

Ropa: Spanish fully tailored overdress, resembling a coat.

Rope: (1) A compact and flexible, generally torsionally balanced continuous structure, greater than 4 mm diameter capable of applying or transmitting tension between two pints. A heavy, strong cord, made from either natural or manufactured fibres or from wire, in a wide range of diameters. Yarns are twisted together to form strands. These strands are then twisted together in the opposite direction to form the rope. The fact that the twist directions alternate at different stages of rope assembly assures that the rope will be twist-stable and will not kink during use. Also called cord. (2) Fabric in process without weft tension, thus having the appearance of a thick rope.

Rope, braided: See **Braided rope**.

Rope creases: Disruptive, longitudinal marks; a problem that occurs in fabric and knitted goods finishing, particularly where dyeing takes place in rope form at higher temperatures. It has been shown in practice that crease inhibitors can minimise this fault. Where impregnation is carried out with plaiting, folds, creases occur either in the padder, when plaited, in the steamer or later during piling.

Rope detwister: A device used in a rope opener to detwist the fabric in rope form to make the rope devoid of twists. The product rope passes between two spring-loaded rollers of the detwister basket, (a) the deflecting roller; (b) and the two sensor rollers; (c) before proceeding to the spreader.

Rope dyeing Machines: These machines process the fabric fed and driven lengthwise to form a rope. The hydrodynamic effect is obtained by means of the motion of the fabric rope, or by means of the simultaneous rope-and-dyebath motion, which ensures a homogeneous contact of the material with the dyeing liquor and a quick exchange of the dyeing liquor dispersed in the material. Machines running according to these operating principle are suitable for treating almost all the fabrics made up of extremely different fibres, woven or knitted fabrics, during preparation and dyeing stages, with only some problems occurring with loose-weave fabrics. During the treatments the fabrics run freely weft-wise and therefore can freely shrink and set thus eliminating almost all tensions. Suitable operating conditions and technical adjustments also reduce to the minimum warp-wise tensions, and continuously move the wrinkles of the rope. An unquestionable benefit obtained with these machines is the extremely soft and fluffy hand, particularly suitable for fabrics to be used for garments. Possible problems are connected to the formation of permanent wrinkles on the fabric, or to uneven dyeing shades, always connected to the problem of the rope wrinkles; for fabrics made up with very delicate or short staple fibres, mechanical stresses can cause losing or extraction of the hair on the surface.

Rope, fibre: See **Fibre rope**.

Rope form: Textile fabric which has been gathered loosely into the form of a rope in the warpwise direction (woven fabrics) or wale direction (knitted fabrics), usually by passage through a ring or pot-eye of suitable diameter for pretreatment and dyeing processes (as opposed to open-width processing).

Rope form processing: The treatment of fabric that has been drawn into the form of a rope, often by passage through a ring (pot-eye) of appropriate diameter.

Rope mark: Also called running mark a long crease mark (q.v.) in a dyed or finished textile and that runs approximately in the length direction. The marks are caused during wet processing in the rope form and may be the result of: (a) for formation of creases along which abrasion or felting may occur; or (b) imperfect penetration or circulation of the processing liquors.

Rope marks, in dye or finished fabrics: A long irregularly shifting longitudinal marking on dye or finished goods or mechanically induced streak.

Rope opener: This spreads all piece goods which are pre-treated in rope form by means of beater rollers, scrollers and spreader rollers.

Rope piler: Device for feeding rope-form piece goods into bleaching vats. It is usually fed in together with a wetting-out liquor. Electric-hydraulic rope pilers have a telescopic tube which can be used for round bleaching vats. Even with varying product speeds from 30–150 m/min (infinitely variable) it ensures an even rope speed without twisting at a variety of rope speeds.

Rope plaiter: Hydrodynamic piece rope plaiter which feeds the rope into the fabric accumulators by means of a rope piling device.

Rope processing: Processing the form of rope, instead of open width. Olden days most of the processing, especially pretreatment, washing etc., was done in the rope form. Nowadays woven fabric is done in the open width form, leave also some specialized processings. Knitted fabric to some extent is done in the rope dorem in Jet / Sft flow dyeing.

Rope ring: (pot-eye). A ring-shaped component forming part of the Rope form handling device for guiding and supporting the product rope.

Rope soaper: (rope washer). Washing, rinsing and finishing device consisting of e.g. 3–5 adjustable pressure squeeze and guide rollers. As well as the washing, rinsing and blueing of bleached goods, it is also used in particular for the chlorine finishing of e.g. the Ce-Es bleaching of fabrics. Obsolete.

Rope squeezing machine: (rope mangles). Are designed to extract water from piece goods treated in rope form. They can be incorporated into some

manufacturing systems as intermediate devices (squeezing units), e.g. washers or autonomous devices (squeezing machines). In the latter case they are usually full-width squeezers.

Rope washing machine: (rope scourers). Are washing machines for washing piece products in rope form. Unlike discontinuous rope washing machines, which consume large amounts of water, continuous rope washing machines operate with smaller amounts of liquid and a specific liquor flow. They almost invariably function on a counter-current basis.

Rope, Plaited: See **Plaited rope**.

Rope, Twisted: See **Twisted rope**.

Roping: A term used for roving in the woollen system of spinning.

Rosella: (1) (pot-eye). A ring-shaped component forming part of the Rope form handling device for guiding and supporting the product rope.

(2) A bast fibre originating in South-East Asia and similar to Kenaf. The length of the basic fibre is about 2–5 mm; its per hectare yield is higher than jute, but it requires more processing. Used as a packaging material.

Rose-point lace: A Venetian needlepoint lace with design connected by a thick thread. It is characterized, as the name suggests, by delicate close flower of leaf designs.

Rot: Rot is chemical decomposition with a mainly alkaline reaction (in contrast to fermentation) and unpleasant odour. It encompasses a variety of indeterminate chemical reactions with the formation of intermediates and soluble end products, which are also released by aerobic and anaerobic bacteria.

Rot resistance: The ability of textile materials to resist physical deterioration resulting from the action of bacteria and other destructive agents such as sunlight or sea water.

Rot steeping: A method of desizing. In this method grey cotton fabric is steeped in water in suitable box at a temperature of about 30–40°C. During the storage micro-organisms develop excreting enzymes which attack the starch. The swollen and hydrolysed starch is thus partially converted into soluble state which are then removed from the fabric by normal washing with water. The main problems in this method are low efficiency due to longer treatment time and degradation of cellulose due to cross-infections of mildew if the fermentation process is not properly controlled.

Rotary cloth press: It should theoretically be possible to achieve a press effect in wool fabrics during continuous processing using calendars that are used in

cotton finishing. However, rotary cloth-presses are predominantly employed in the continuous dry finishing of Wool, in order to compress fabrics.

Rotary Cutter, in garmenting: It is a round, very sharp blade attached to a handle and is used to cut out fabric. It should always be used with a rotary cutting mat.

Rotary dryers: Devices commonly used in the chemical industry for the drying, mixing, and sintering of solids. They consist essentially of a rotating inclined cylinder, which is longer in length than in diameter. Gases flow through the cylinder in either a countercurrent or cocurrent direction to regulate the flow of solids, which are fed into the end of the cylinder. Rotary dryers can be applied to both batch and continuous processes.

Rotary drum drier: A sieve-drum drier where the fabric is guided almost all the way around the drum, for the dry treatment and/or thermal treatment of tubular and/or web qualities. Their compact, high-productivity design with little space requirements make them particularly suitable for small and medium-sized shops.

Rotary extraction cleaning: A cleaning procedure which uses a rotating brush machine or a series of rotating jets through which shampoo is fed or sprayed on to the carpet pile and simultaneously removed by suction.

Rotary irons: A further development of Ironing machines and steam ironing dummies used for finishing outerwear in one fully automated process (Steam ironing dummy).

Rotary press: A combination of 4 ironing presses for transfer printing. The transfer printing processes are cyclic, and hence continuous. There are 4 stations: (a) uptake of the material; (b) uptake of the thermal transfer paper; (c) transfer; (d) cooling and removal of the transfer material.

Rotary screen coating machine A device to provide an even coat of screen lacquer to rotary screens. The lacquer is applied in a single process using a variety of different lacquer types on rotary screens from the top downwards with the help of a rubber doctor roll.

Rotary screen coating machine: Rotary screen coating machine A device to provide an even coat of screen lacquer to rotary screens. The lacquer is applied in a single process using a variety of different lacquer types on rotary screens from the top downwards with the help of a rubber doctor roll.

Rotary screen printing The process of screen printing using rotary screens. The screen is not placed flat in a frame, but takes the form of a hollow roller. The advantage over automatic Flat screen printing is a substantially higher level of continuous production (similar to roller printing). The advantage over

roller printing is greater ease of changing dye and design, as rotary screens can be inserted and removed by hand, without the need for lifting blocks.

Rotary screen washing: Rotary screen washing is carried out in a screen washing cabinet by means of a spray ring on the outside and a spray head fitted with a nozzle on the inside.

Rotary shampoo: A cleaning procedure which uses a rotating brush machine through which shampoo is fed into the pile of a textile floor covering.

Rotating rod drier: A continuous hank yarn drier with rotating yarn rods which rotate while passing through the machine and which are closely spaced and allow air to flow between them so that the circulated air is fully utilised and the yarn is well aired. Dry treatment in a misty atmosphere at stepped temperatures up to the infeed of the wet product (resulting in the maximum possible protection, easy handling yarn with an even residual moisture content and low vapour consumption).

Rotation cast button: A button fabricated from a disc blanked from a partially polymerized sheet formed in a rotating cylinder.

Rotonde: Long, circular cut cape for women; also called a wrap.

Rotor spinning: See **Open-end spinning**.

Rotor, In open end spinning machine: A device resembling a centrifuge, in which the fibres are assembled in and in which, by virtue of its rotation, real twist is inserted in the forming yarn.

Rotor atomizer: This coating system basically consists of a rotor support, hydraulic control device, liquor container unit and centrifugal pump. The rotors turn at approximately 5000 rpm and distribute the treatment liquid over the product with droplets of approximately 30 mm.

Rotor damping: A method for damping fabric and for low wet pick-up. It operates without jet nozzles. The equipment consists of a rotor support, a hydraulic control unit, liquor container and centrifugal pump. The liquor is finely dosed. The rotors (approx. 500 rpm) spray a part of the liquor as very flat spray in the form of tiny droplets (diameter approx. 30 mm) at a vertical sheet of fabric. The spray width is approximately 100–400 mm. The staggered sprays and overlapping zones result in a spray width of 180–280 mm for approximately 800 ml/m/min.

Rotor spinning: See **Open end spinning**. (OE yarn). Fibre yarn produced by means of rotor or turbine spinning process (OE spinning process). Individual fibres are removed from slubbings and are continuously added to a spinning open yarn end by an air current from a rotating turbine. This method of

spinning results in carded -type yarn with typical qualities differing from those of ring-spun yarn Ring-spun/rotor-spun yarns, properties of.

Rotor type open-end spinning machine: An open end spinning machine wherein the assembly of individual fibres and the insertion of real twist are effected by the rotor.

Rotor Washing Machine: Washing machines with a divided inner drum uni-directional. Used in the multi-bath or Flow washing process. Advantages: idle time for reversal of drum rotation is eliminated, thus ensuring a shorter washing process (= levelling for compression treatment reduces washing requirements) and smooth inner drum rotation.

Rotor-Spun Yarn: Open-end spun yarn.

Rouching: Fabric is drawn up with a thread or drawstring to create a full, gathered effect within a garment.

Rough: A descriptive term for a fabric surface which has the feel of sand paper.

Rough: Peruvian Cotton, having very clean, moderately strong but harsh and wiry staple of a light cream colour.

Rough place: See **Temple mark**.

Rough selvage: See **Loopy selvage**.

Roughness: It is understood as the unevenness of a surface. It can be described geometrically by the size of the roughness elements, or mechanically by the friction coefficient. When touched with a finger, the roughness is not noticeable. However, if a finger is moved across the surface at a constant speed (approx. 3–4 cm/s), the movement receptors in the finger are rhythmically stimulated. These groups of impulses are perceived as roughness, the time between the individual impulses reproducing the roughness. The contact pressure is close to the contact threshold so that the roughness is identified from the friction cause.

Roumanian stitch: An Embroidery stitch. Bring the thread through at the top left of the shape. Carry the thread across and take a stitch on the right side of the shape with the thread below the needle. Take a stitch at left side. Thread above needle These two movements are worked until the shape is filled keep the stitches close together. The size of the center crossing stitch can be varied to make a longer oblique stitch or a small straight stitch.

Round Twill: It is based on the satin weave, forming round diagonal ribs.

Roundabout: A short jacket reaching to the waist.

Rouzet or Roustet: Coarse strong French woollen used for cheap clothing.

Rove, in jute processing: A continuous strand of spun-jute fibre having a spindle number of 50 or greater.

Roving: A loose assemblage of fibres drawn or rubbed in to a single strand, with very little twist. In spun yarn systems, the product of the stage, or stages, just prior to spinning.

Roving, in glass textiles: A multiplicity of filaments or yarns gathered together into an approximately parallel arrangement without twist.

Roving: A loose assemblage of fibres drawn or rubbed into a single strand with very little twist.

Roving: (1) In spun yarn production, an intermediate state between sliver and yarn. Roving is a condensed sliver that has been drafted, twisted, doubled, and redoubled. The product of the first roving operation is sometimes called slubbing.

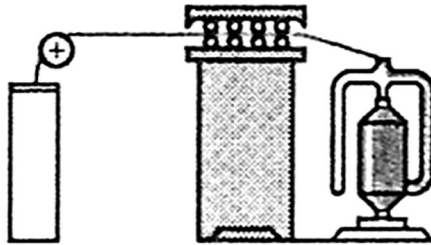

Roving (Schematic)

(2) The operation of producing roving. (3) In the manufacture of composites, continuous strands of parallel filaments.

Roving Construction number, in asbestos: A system designed to show the construction namely, the cut of single roving and whether enforcement is present.

Roving frame: A general name for all of the machines used to produce roving, different types of which are called slubber, intermediate, fine, and jack. Roving frames draft the stock by means of drafting rolls, twist it by means of a flyer, and wind it onto a bobbin.

Roving, reinforced asbestos: Asbestos roving containing a reinforcement of one or more strands of other fibres or wire.

Rowdy: Flaw in cloth, consisting of streaks.

Rowey: See **Uneven surface.**

Rowing Shirt: A low-necked shirt with very large deep armholes.

Rows: In woven oil floor covering: The average number of pile tufts per inch in warpwise direction.

Royal Armure: A narrow, stout silk dress fabric, woven with a pebbled face.

Royal-Axminster carpet: A carpet having a tufted cut pile, formed by the loom.

Royal cashmere: Fine English summer dress goods of wool warp and worsted filling.

Royal Rib: Same as cardigan.

Royale: Silk dress goods, similar to Gros de Tours, made with two harnesses, four warp ends in each heddle.

Royale weave: Royale is a modification of the regular Gros de Tours, inasmuch as the rib line, which in the latter runs straight across the cloth, is broken off after a given number of warp-threads. These groups, which may comprise 8, 12 or more threads, will interlace each one pick higher than the preceding one.

Royalette: In England a stout fabric made with cotton warp and Botany filling, woven in five-leaf weft satin weave.

Ruanas: Cotton ponchos in Columbia, made in plain weave, usually narrow woven stripes placed three-quarter inch apart.

Rub: See **Abrasion Mark**.

Rubber: A material that is capable of recovering from large deformations quickly and forcibly, and can be, or already is, modified to a state in which it is essentially insoluble (but can swell) in boiling solvent, such as benzene, methyl ethyl ketone, and ethanol-toluene azeotrope.

Rubber: A natural or synthetic polymeric elastic material. Natural rubber is a polymer of methylbuta-1,3-diene (isoprene). Various synthetic rubbers are made by polymerization; for example chloroprene rubber (from 2-chlorobuta-1,3-diene) and silicone rubbers. See vulcanization.

Rubber cloth: Cotton fabric, rubberized on one side, used for raincoats in the lighter weights and suit cases and carriage trimmings in the coarser grades.

Rubber coated Textile Fabric: Specialised fabrics made by coating Rubber, examples are water proof sheeting etc.

Rubber compound: An intimate mixture of elastomer(s) with all materials necessary for the finished article.

Rubber fibre: A manufactured fibre in which the fibre forming substance is comprised of natural or synthetic rubber including the following categories.
(1) A manufactured fibre in which the fibre forming substance is a hydrocarbon

such as natural rubber, polyisoprene, polybutadiene, copolymer of dienes and hydrocarbons or amorphous (noncrystalline) polyolefins. (2) A manufactured fibre in which the fibre forming substance is a copolymer of acrylonitrile and a diene (such as butadiene) composed of not more than 50 % but at least 10 % weight of acrylic nitrile units $-\text{CH}_2-\text{CHCN}-$. The term 'lastrile' may be used as a generic description for the fibre falling in the category. (3) A manufactured fibre in which the fibre forming substance is polychloroprene or a copolymer of chloroprene in which at least 35 % by weight of the fibre forming substance is composed of chloroprene units $(-\text{CH}_2-\text{CCl}=\text{CH}-\text{CH}_2-)$.

Rubber Filament: A filament extruded from natural or synthetic rubber and used as the core of some elastic threads.

Rubber Thread: Thread made of Rubber used mainly before the invention of Elastanes. See **Rubber Filaments**.

Rubber velvet: Consists of a rubberized cloth ground over which coloured flock is blown while the rubber is still soft, giving it a soft, velvety face. Used for raincoats.

Rubberise: See **Rubberising**.

Rubberising: To impregnate or coat with rubber compound or both.

Rubbing fastness testing: (crock fastness testing). A test to check the resistance of textiles and their dyes against soiling and crocking during use; The guidelines apply to all fibre types all standards are almost same. For dry fastness, dry dyed material is rubbed with dry cotton fabric; for wet rub fastness, dry dyed material is rubbed with wet cotton fabric; it can be carried out with a special rub tester (crockmeter). The fabric is rubbed to and fro 10 times over 10 cm for 10 seconds, at a load of approximately 1000 g. The staining of the cotton rubbing cloth is then compared against the grey scale/stain.

Rubbing fastness, Dry: See **Rubbing fastness testing**.

Rubbing fastness, Wet: See **Rubbing fastness testing**.

Ruby number: A value used for protective colloid effects of textile auxiliaries. It is based on protection against precipitation of a sodium chloride solution, with a solution of Congo ruby A being used as an indicator. The ruby number is the protective colloid in mg, which is just able to prevent the colour change to violet after 10 minutes.

Ruff: Spanish projecting frill of several layers of starched, pleated fabric worn around the neck.

Ruffles: Strips of fabric cut from circles and then opened out and applied inside a band or on a seam. They can be of any width, but may need to be seamed together to create a long ruffle

Rug: (1) Thick and heavy floor covering made of cotton, wool, silk or jute, made with or without any pile, by hand or on the loom, covering of a limited area which is complete in itself and is intended for use as a partial covering of a floor or another floor covering.; also a twilled and figured blanket used for traveling; (2) Coarse woollen fabric worn by the poorer classes in England during the 16th century.

Rug Back: (1) Double shed back, given to carpets and rugs to increase their wearing quality or that part of a rug normally in contact with the floor; (2) the underside of a rug as opposed to the use surface.

Rugby: In England a stout, coloured cotton shirting.

Ruggedness test: An experiment in which environmental or test conditions are deliberately varied to evaluate the effect of such variations.

Rugging: In England a stout, coarse woollen fabric, finished with a thick nap on the face; used for floor covering.

Rugginose: Waste silk, obtained from stained or imperfect cocoons.

Rumal: An old Indian art still practiced today, where fine cotton headscarves and wedding cloths are silk embroidered with figures. Sometimes graced with delicate needle work and motifs, often featuring the Hindu deity Krishna. Infused with the beauty of miniature paintings, these rumals were traditionally gifted during festivals and ceremonies and also used to cover wedding gifts.

Rumburg Linen: A Fine Austrian linen, the fineness and number of yarns in the warp and weft are alike.

Run: The unit in the American system of woollen yarn count, meaning 1,600 yards of yarn in a hank, the number of hanks giving the yarn count.

Run-in: This is the yarn consumption of each guide bar at warp knitting and it is the length of each yarn knitted into fabric during 480 knitting cycles (one rack).

Run-in ratio: this is the ratio of run-in value of different guide bars at warp knitting.

Run Work: A needlework, consisting in running white or coloured thread through the meshes of a net to form a design.

Run, in experimenting or testing: A single performance or determination using one of a combination using one of a combination of experimental or test conditions.

Run, in knitted fabrics: A series of dropped stitches.

Run, in the wool system: The number of 1600 yd. Lengths of yarn per pound. An indirect yarn numbering system generally used for yarns spun on the woollen system.

Runner: See **End out**.

Runner: A break in the yarn of a knit fabric that causes the stitch to “run” along the needle line (wale) in a vertical direction. See **End out**.

Runner length: In knitting, the number of inches of yarn from a warp to make one rack of fabric.

Runner, carpet: A long narrow length of textile floor covering finished at both ends.

Running and back stitch: The running and back stitch is made by taking a few running stitches, drawing out the needle and making a back stitch over the last running stitch to strengthen the seam. Care must be taken not to hold the side next the worker too full and not to miss the under material, but to take the stitches even on both sides.

Running speed: The speed at which a textile product being treated passes through a section, e.g. a finishing machine. It is measured in m/min, while the rotational speed is given in rpm; in weaving machines running speed is measured by weft insertions/min.

Running stitch: A continuous embroidery stitch formed by passing the thread through the material alternately from top to under side and vice versa. Method: Pass the needle over and under the fabric, making the upper stitches of equal length. The under stitches should also be of equal length, but half the size or less of the upper stitches.

Run-of-the-mill: See **Mill run**.

Run-proof: A knitted construction in which the loops are locked to prevent runs.

Run-resistant: A type of knitting stitch that reduces runs.

Rupture: The breaking or tearing apart of a material.

Russel/Russel cord: Cord Union fabric made with cotton warp and worsted filling, two warp ends being run through each dent, forming cords.

Russia: Braid Made of silk or mohair for embroidery purposes.

Russian cord: A colour striped shirt or dress fabric in which the cord stripes are produced by leno weaving. One end is made to cross a number of ends in an alternate crossed and open shed sequence.

Russia Crash: Coarse, strong, plain woven unbleached cloth made of hemp or coarse linen yarn. Used for towels, coats, etc.

Russian Blanket: Very heavy blanket with thick nap raised on both sides, made with wool warp and heavy mohair filling, usually in different coloured stripes. Used for automobile robes.

Russian Duck: Fine bleached linen canvas, used for summer clothing. A heavier grade is used for sail cloth.

Russian hemp Identical to Pita fibre; See **Mauritius hemp**.

Russian Lace: Coarse crochet lace of cotton or linen with simple patterns.

Russian Serge: A very strong, thick all wool serge for women's coats.

Russian Twill: Trade name for fine, clear faced twilled woollen dress goods, woven of right hand twist yarn and dyed in the piece.

Russian Veiling: Cotton veiling made with large meshes and square patterns woven between them.

Rusty Silk: Flaw in white or delicate coloured silk cloth showing fine brownish streaks in the filling.

Rutile: A modification of Titanium dioxide. Used as a white pigment in textile pigment printing.

Rya carpet Scandinavian long-pile carpets in characteristic colours and patterns. They were originally hand-knotted from rough wool (genuine Rya). They are now machine-woven by various processes.

Rhythm, in garment designing: Rhythm is the repeated use of lines or shape to create a pattern. Rhythm also refers to a feeling of movement. Rhythmic use of design elements lead the eye through a design giving the garment a continuity e.g.:- use of laced trims and contrasting cuffs and collars lead the eye through the design with a successful rhythm. The eye should travel without effort from one part to the other.

Rhythm, Linear refers to the characteristic flow of individual line. Linear rhythm is not as dependent on pattern, but it is more dependent on timed movement of the viewer's eye. See **Rhythm**.

