

The McGraw-Hill Companies

Civil Engineering Series



Second Edition

S K Duggal



SURVEYING'S

Volume 1

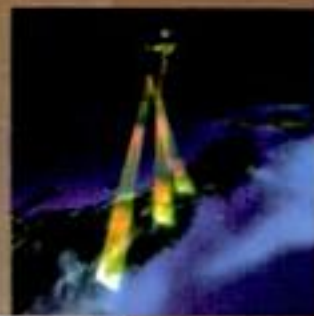

Chapter 1

Fundamental Concepts

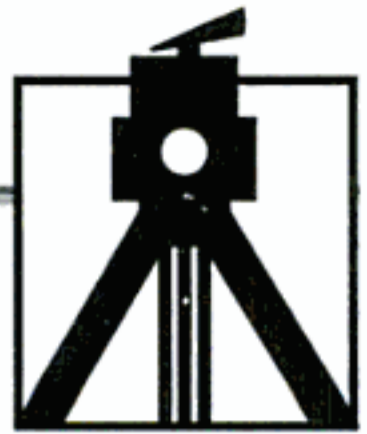

1.1 INTRODUCTION

Surveying is one of the oldest arts practised by man. History reveals that the principles and practices of surveying were used, consciously or unconsciously, even in the primitive ages, albeit in a crude manner. In the past few decades, however, these have become more rational and channelised.

The introduction and practice of surveying is indispensable to all branches of engineering. The training that a student receives, irrespective of his branch of engineering, in the art of observing, recording, and computing data, as well as in the study of errors their causes and effects, directly contribute to his success in other professional courses. He develops *inter alia* such qualities as self-reliance, initiative and the ability to get along with the others. This also helps an engineer get acquainted with the reasonable limits of accuracy and the value of significant figures. A knowledge of the limits of accuracy can best be obtained by making measurements with the surveying equipment employed in practice, as these measurements provide a true concept of the theory of errors. An engineer must also know when to work to thousandths, hundredths or tenths of a metre and what precision in field data is necessary to justify carrying out computations to the desired number of decimal place. With experience, he learns how the funds, equipments, time, and personnel available will govern the procedure and the results. Taking field notes under all sorts of field conditions trains a person to become an excellent engineer, capable of exercising independent judgements.

Surveying is of special importance and interest to a civil engineer. Surveys are required prior to and during the planning and construction of buildings, dams, highways, railways, bridges, canals, tunnels, drainage works, water supply and sewerage systems, etc. They may also be required for planning and construction of factories, assembly lines, jigs, fabrications, missile ranges, launch sites, and mine shafts. Surveying is the starting point for any project or constructional

scheme under consideration. Details of the proposed work are plotted from the field notes. The reliability of the estimation of quantities and the effectiveness of the design depends upon the precision and thoroughness exercised during the survey.

Today, the art of surveying has become an important profession. An introduction to the principles and practices of surveying is, therefore, desirable as an integral part of engineering education and training, irrespective of the branch of specialization. A knowledge of surveying trains the ability of engineers to visualize, think logically, and pursue the engineering approach. It promotes a feeling of confidence, a habit of working in groups, neatness and care in documentation, and begin interpersonal relations by the way of simultaneous and tactful handling of clients. For a better understanding of the discussions to follow, brief definitions of a few important terms as applied in surveying are presented.

1.2 DEFINITIONS

The Earth Surface The earth is not a true sphere and a slightly flattened at the poles. Its polar axis is somewhat smaller in length (about 43.45 km) than that of its equatorial axis. Any section of the earth parallel to the equator is a circle and any of its section parallel through the poles is an ellipse. Such a figure may be generated by revolving about its minor axis and is called an oblate spheroid. Precisely, the equatorial section is also slightly elliptical and therefore such a figure should be called an ellipsoid. Precise observations indicate that the southern hemisphere is a trifle larger than the northern. Therefore, all the polar sections are oval and can be called ovaloid.

In fact, no geometrical solid represents the true shape of the earth. The earth is also recognized by a new name, geoid. However, for all measurement purposes in surveying, the irregularities of the earth's surface, as discussed above, may be assumed to be absent and the resultant surface be considered a spheroid.

Level Surface A level surface is a curved surface, every point on which is equidistant from the centre of the earth and every surface element is normal to the plumb line. It is parallel to the mean spheroidal surface of the earth. However, for plane or ordinary surveying, a level surface at any point is assumed to be a plane surface perpendicular to the plumb line at that point. The particular surface at the average sea level is known as mean sea level.

Great Circle Imagine a plane passing through the centre of the earth (Fig. 1.1). The intersection of such a plane with the mean level surface of the earth is termed as the great circle of the earth.

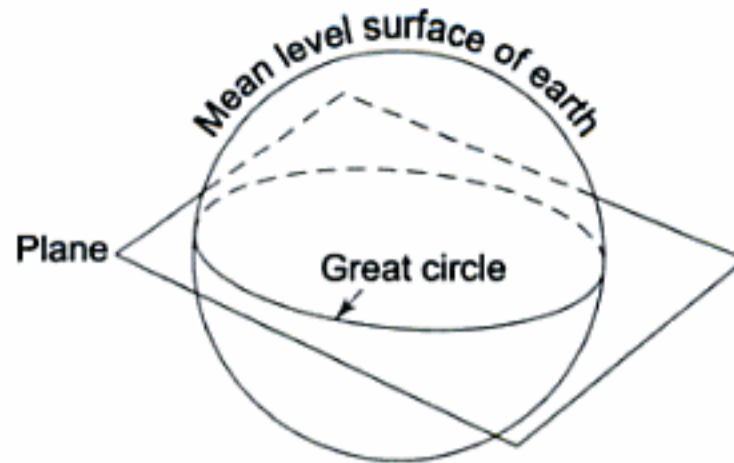

Fig. 1.1

Meridian It is the line defined by the intersection of an imaginary plane, passing through the poles and any point on the earth's level surface, e.g. A (Fig. 1.2).

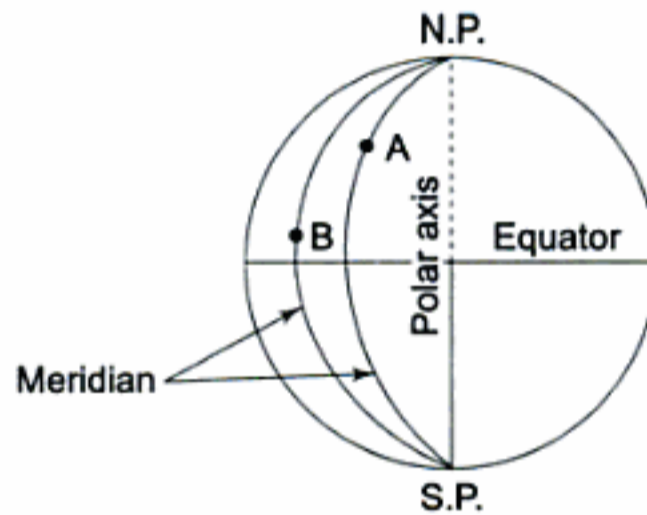

Fig. 1.2

Plumb Line The plumb line is normal to the meridian. Considering the mean level surface of the earth as spherical, these lines converge at the centre of the earth (Fig. 1.3).

☑ **Note** Earth being an oblate spheroid, the perpendiculars to the surface do not converge at any point. The irregular distribution of the earth's mass also causes some deviations. But for plane surveying, all such deviations are ignored and plumb lines are assumed to converge at the centre of the earth.

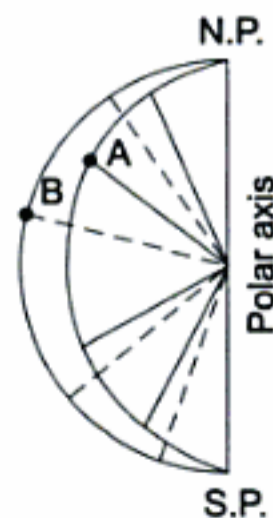

Fig. 1.3

Level Line Any portion of the line lying on the great circle of the earth is called a level line. It may also be defined as a line lying on the level surface and normal to the plumb line at all the points.

Horizontal Plane and Line A plane through any point on the earth's mean level surface and tangent to the surface at that point is known as horizontal plane. A line lying in the horizontal plane is termed as horizontal line. Through any point on the earth's surface, there can be only one horizontal plane but infinite horizontal lines.

Vertical Plane and Line A line through a point perpendicular to the horizontal plane is called a vertical line. A plane passing through that point and containing the vertical line is termed as vertical plane. Through any point on the earth's surface, there can be only one vertical line but infinite vertical planes.

Spherical Triangle Imagine three points A, B and C (Fig. 1.4) on the mean level surface of the earth. The three points when joined form a triangle having a curved surface ABC, and AB, BC and CA being the arcs. The triangle ABC is known as a spherical triangle and the angles A', B' and C' are spherical angles. The amount by which the sum of the angles of a spherical triangle exceeds by 180° is called *spherical excess*.

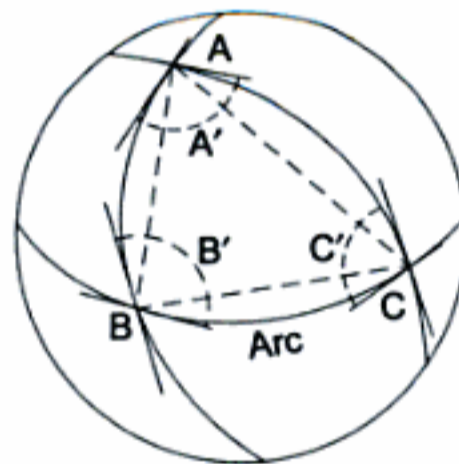

Fig. 1.4 Spherical triangle

Grade It is defined as the slope of a line. It is also called *gradient*.

Elevation It is the vertical distance of a point above or below the reference surface (datum). When elevations are with respect to the earth's surface, the datum is the mean sea level. The datum is a curved surface and, therefore, its curvature should be given due consideration even while determining elevations in plane surveying. An imaginary line joining points of equal elevations is known as contour.

1.3 SURVEYING

It is defined as an art to determine the relative positions of points on, above or beneath the surface of the earth, with respect to each other, by measurements of horizontal and vertical distances, angles and directions.

A person performing operations to obtain such measurements is known as a surveyor. In his day-to-day work, a surveyor deals with a very small portion of the earth's surface. However, he is the best judge with regard to the earth's surface as plane or curved depending upon the character, magnitude of the work and the precision desired.

The purpose of surveying is to determine the dimensions and contours of any part of the earth's surface, i.e. to prepare a plan or map, establish boundaries of the land, measure area and volume, and select a suitable site for an engineering project. Both plans and maps are the graphical representations of the features on a horizontal plane. The former is a large-scale representation whereas the latter is a small-scale one. When the topography of the terrain is depicted on map with contours and spot levels, etc., it is called a *topographic map*.

Scale is defined as the fixed proportion which every distance between locations of the points on the map bears to the corresponding distances between their positions on the earth's surface. Primary considerations in choosing the scale for a particular project are those to which the map will be put and the extent of the territory to be represented. For most of the engineering projects, the scale varies from $1 \text{ cm} = 2.5 - 100 \text{ m}$. Frequently, the choice of the scale is restricted to some scale small enough so that the whole map will fall within a rectangle of a given size, the dimensions of which are determined by the size of blue print frame, or by the size of sheet most convenient for handling. The following rules may be observed in deciding the scale.

1. Choose a scale large enough so that in plotting or in scaling distances from the finished map it will not be necessary to read the scale closer than $1/100$.
2. Choose as small a scale as is consistent with a clear delineation of the smallest detail to be plotted, due regard being paid to rule 1.

A scale may be represented numerically by engineer's scale or representative fraction. The engineer's scale is represented by a statement, e.g., $1 \text{ cm} = 40 \text{ m}$.

When a scale is represented by a fraction whose numerator is invariably unity, it is called a representative fraction. In forming the representative fraction, both the numerator and the denominator must be reduced to the same denomination. For a scale of $1 \text{ cm} = 1 \text{ km}$, the representative fraction is $1/100,000$.

The representative fractions and scales recommended for various types of maps are as follows:

Type	Representative Fraction (R.F.)	Scale
Geographical map	1 : 16 000 000	1 cm = 160 km
Topographical map	1 : 250 000	1 cm = 2.5 km
Location map	1 : 500 to 1 : 2500	1 cm = 5–25 m
Forest map	1 : 25 000	1 cm = 0.25 km

(Contd.)

6 Surveying

Type	Representative Fraction (R.F.)	Scale
Cadastral map	1 : 1000 to 1 : 5000	1 cm = 10–50 m
Town planning	1 : 5000 to 1 : 10000	1 cm = 50–100 m
Buildings	1 : 1000	1 cm = 10 m
Mines	1 : 1000 to 1 : 25000	1 cm = 10–25 m
Preliminary survey of rails and roads	1 : 1000 to 1 : 6000	1 cm = 10–60 m

Another most suitable method used to represent the scale of a map is the graphical scale. It is a line drawn on the map so that its distance on the map corresponds to a convenient unit of length on the ground. Figure 1.5 shows a graphical scale corresponding to a scale of 1 cm = 5 m. A 12 cm long line, divided into six equal parts of 2 cm each, is drawn on the map. Thus, each part represents 10 m on the ground. The first part is divided into 10 equal divisions, each representing 1 m. Figure 1.5 shows a distance of 36 m marked on the scale.

It is necessary to draw a scale on a map because as the map shrinks or expands, the scale line also shrinks or expands with it and thus the measurements made from the map are not affected.

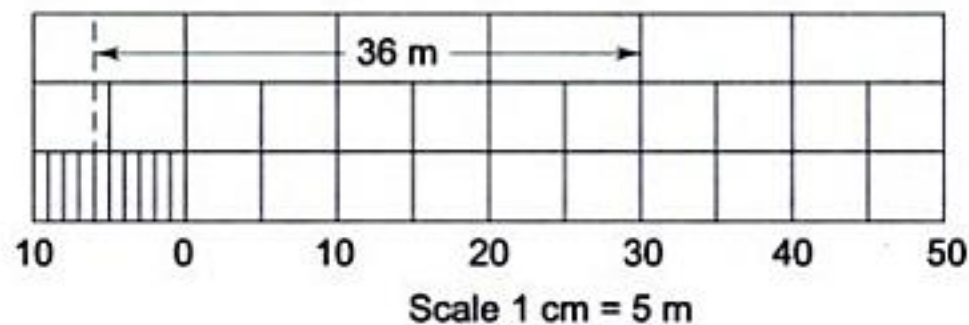

Fig. 1.5 Geographical scale

The ratio of the shrunk length to the actual length is known as the shrinkage ratio (S.R.) or the shrinkage factor (S.F.).

$$\text{S.F.} = \frac{\text{shrunk length}}{\text{original length}} = \frac{\text{shrunk scale}}{\text{original scale}} = \frac{\text{shrunk R.F.}}{\text{original R.F.}}$$

$$\text{Thus, correct distance} = \frac{\text{measured distance}}{\text{S.F.}}$$

$$\text{and correct area} = \frac{\text{measured area}}{(\text{S.F.})^2}$$

If a wrong measuring scale is used to measure the length of a line already drawn on a plan or map, the measured length will be erroneous. Then

$$\text{correct length} = \frac{\text{R.F. of the wrong scale}}{\text{R.F. of the correct scale}} \times \text{measured length}$$

and $\text{correct area} = \left[\frac{\text{R.F. of wrong scale}}{\text{R.F. of correct scale}} \right]^2 \times \text{measured area.}$

1.4 PRINCIPLES OF SURVEYING

There are two basic principles of surveying. These find their inherent applications in all the stages of a project, i.e. from initial planning till its completion.

1. To work from whole to part.
2. To locate a point by at least two measurements.

1.4.1 To Work from Whole to Part

It is the main principle of surveying and a method violating the principle of working from whole to part should not be adopted until and unless there is no alternative.

The main idea of working from whole to part is to localize the errors and prevent their accumulation. On the contrary, if we work from part to whole, the errors accumulate and expand to a greater magnitude in the process of expansion of survey, and consequently, the survey becomes uncontrollable at the end. This can be explained by taking a simple example of measuring a horizontal distance AB, say about 120 m with a 20 m chain (Fig. 1.6). The process consists in measuring the distance in parts, as the length of chain is smaller than the distance to be measured and is accomplished by the process of ranging. There can be two alternatives.

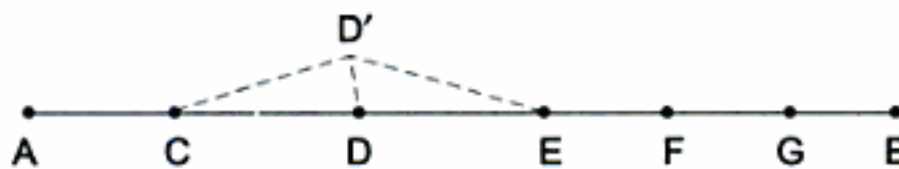

Fig. 1.6 (a)

In the direct method, various points such as C, D, and E are established independently at a distance of about 20 m each with respect to the two end control points and the distance AB can be measured. As C, D, E, etc. are established independently with respect to the main control points, error, if any, introduced in establishing any intermediate point will not be carried in establishing the other points. For example, suppose that point D has been established out of the line AB, as D' (Fig. 1.6 (a)) and E, F, etc., have been established correctly. The actual distances DC and DE will be in error (D'C and D'E) but all other distances AC, EF, FG, etc. will be correct. Therefore, the error in this procedure is localized at point D and is not magnified. This method observes the principle of working from whole to part.

In the other method, a part, say AC, of the whole distance AB to be measured is fixed by fixing a point C as C' by judgment or by the process of ranging. Then the other points D, E, F, etc. are fixed with respect to A and C'. Now if point C

is not in line with AB, all the points D, E, F, etc. established will be out of line with an increasing magnitude of error (Fig. 1.6(b)). The length measured will, therefore, be incorrect to a larger extent as compared to the direct method. This method may introduce serious error as the survey at the end becomes uncontrollable and hence working from part to whole is never recommended.

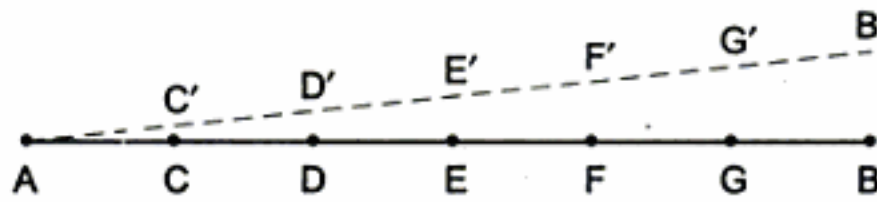

Fig. 1.6(b)

1.4.2 To Locate a Point by at Least Two Measurements

Two control points (any two important features) are selected in the area and the distance between them is measured accurately. The line joining the control points is plotted to the scale on drawing sheet. Now the desired point can be plotted by making two suitable measurements from the given control points.

Let A and B be the two control points, whose positions are already known on the plan. The position of C can be plotted by any of the following methods.

1. By measuring distance BC and angle α , as shown in Fig. 1.7(a).
2. By dropping a perpendicular from C on the line AB and measuring either AD and CD or BD and CD, as shown in Fig. 1.7(b).
3. By measuring the distances AC and BC, as shown in Fig. 1.7(c).

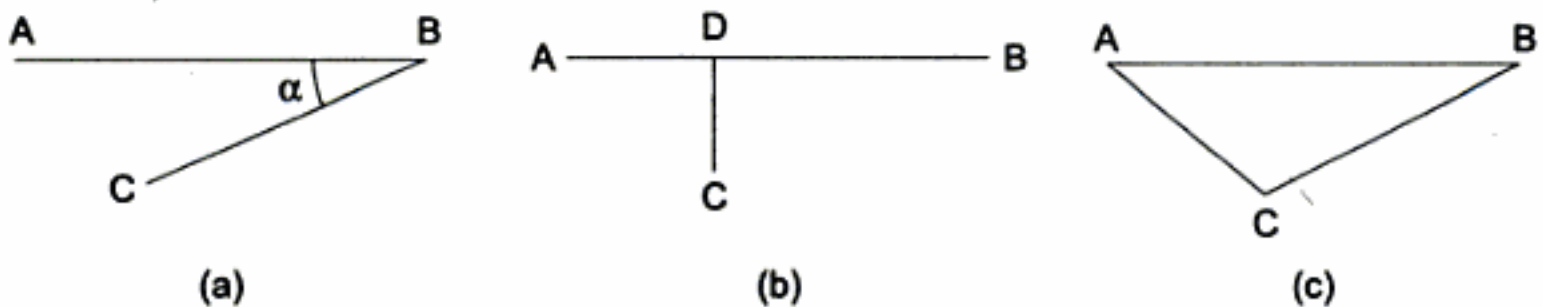

Fig. 1.7

1.5 CLASSIFICATION OF SURVEY

An attempt has been made here to group the types of survey. However, it is not that significant or satisfactory as there are differences in objectives and dissimilarities in the procedures employed to distinguish between them.

1.5.1 Based on Accuracy Desired

Plane Survey Survey in which the mean surface of earth is regarded as plane surface and not curved as it really is, is known as plane surveying. The following assumptions are made:

- (i) A level line is considered a straight line and thus the plumb line at a point is parallel to the plumb line at any other point.
- (ii) The angle between two such lines that intersect is a plane angle and not a spherical angle.
- (iii) The meridians through any two points are parallel.

When we deal with only a small portion of earth's surface, the above assumptions can be justified. The error introduced for a length of an arc of 18.5 km is only 0.0152 m greater than the subtended chord and the difference between the sum of the angles of spherical triangle and that of plane triangle is only one second at the earth's mean surface for an area of 195.5 km^2 . Therefore, for the limits of the provisions stated above, the survey may be regarded as a plane survey.

Plane surveys are done for engineering projects on large scale such as factories, bridges, dams, location and construction of canals, highways, railways, etc., and also for establishing boundaries.

Geodetic Survey Survey in which the shape (curvature) of the earth's surface is taken into account and a higher degree of precision is exercised in linear and angular measurements is termed as geodetic surveying. Such surveys extend over large areas.

A line connecting two points is regarded as an arc. The distance between two points is corrected for the curvature and is then plotted on the plan. The angles between the intersecting lines are spherical angles. All this necessitates elaborate field work and considerable mathematical computations.

The geodetic surveying deals in fixing widely spaced control points, which may afterwards be used as necessary control points for fixing minor control points for plane survey. This is carried out by the Department of National Survey of India.

1.5.2 Based on Instrument Used

Chain Survey When a plan is to be made for a very small open field, the field work may consist of linear measurements only. All the measurements are done with a chain and tape. However, chain survey is limited in its adaptability because of the obstacles to chain like trees and shrubs. Also, it cannot be resorted to in densely built-up areas. It is recommended for plans involving the development of buildings, roads, water supply and sewerage schemes.

Traverse Survey When the linear measurements are done with chain and tape and the directions or angles are measured with compass or transit respectively, the survey is called traversing. In traversing, speed and accuracy of the field work is enhanced. For example, the boundaries of a field can be measured accurately by a frame work of lines along it forming an open traverse. On the other hand, in a densely populated area, the survey work can be carried out with a frame work of lines forming a closed traverse. A traverse survey is very useful for large projects such as reservoirs and dams.

Tacheometry This is a method of surveying in which both the horizontal and vertical distances are determined by observing a graduated staff with a transit equipped with a special telescope having stadia wires and anallatic lens. It is very useful when the direct measurements of horizontal distances are inaccessible. It is usually recommended for making contour plans of building estates, reservoirs, etc.

Levelling This is a method of surveying in which the relative vertical heights of the points are determined by employing a level and a graduated staff. In planning a constructional project, irrespective of its extent, i.e. from a small building to a dam, it is essential to know the depth of excavation for the foundations, trenches, fillings, etc. This can be achieved by collecting complete information regarding the relative heights of the ground by levelling.

Plane Tabling It is a graphical method of surveying in which field work and plotting are done simultaneously. A clinometer is used in conjunction with plane table to plot the contours of the area and for filling in the details. This method of surveying is very advantageous as there is no possibility of omitting any necessary measurement, the field being in view while plotting. The details like boundaries, shore lines, etc. can be plotted exactly to their true shapes, being in view. The only disadvantage of plane tabling is that it cannot be recommended in humid climate.

Triangulation When the area to be surveyed is of considerable extent, triangulation is adopted. The entire area is divided into a network of triangles. Any one side of any of the triangles so formed, is selected and is measured precisely. Such a line is called baseline. All the angles in the network are measured with a transit. The lengths of the sides of all the triangles are then computed from the measured length of the baseline and the observed corrected angles with help of sine formula.

$$\frac{a}{\sin A} = \frac{b}{\sin B} = \frac{c}{\sin C}$$

1.5.3 Based on Purpose of Survey

Engineering Survey Surveys which are done to provide sufficient data for the design of engineering projects such as highways, railways, water supply, sewage disposal, reservoirs, bridges, etc. are known as engineering surveys. It consists of topographic survey of the area, measurement of earth work, providing grade, and making measurements of the completed work till date. These are also known as construction surveys.

Defence Survey Surveys have a very important and critical application in the military. They provide strategic information that can decide the course of a war. Aerial and topographical maps of the enemy areas indicating important routes, airports, ordnance factories, missile sites, early warning and other types of radars, anti-aircraft positions and other topographical features can be prepared.

Aerial surveys can also provide vital information on location, concentration and movement of troops and armaments. This information may be used for preparing tactical and strategic plans both for defence and attack.

Geological Survey In this both surface and sub-surface surveying is required to determine the location, extent and reserves of different minerals and rock types. Different types of geological structures like folds, faults and unconformities may help to locate the possibility of the occurrence of economic minerals, oils, etc.

Geographical Survey Surveys conducted to provide sufficient data for the preparation of geographical maps are known as geographical surveys. The maps may be prepared depicting the land use efficiency, sources and intensity of irrigation, physiographic regions and waterfalls, surface drainage, slope height curve and slope profile and contours as well as the general geology of the area.

Mine Survey In this both surface and underground surveys are required. It consists of a topographic survey of mine property and making a surface map, making underground surveys to delineate fully the mine working and constructing the underground plans, fixing the positions and directions of tunnels, shafts, drifts, etc., and preparation of a geological map.

Archaeological Survey These are done to unearth the relics of antiquity, civilizations, kingdoms, towns, villages, forts, temples, etc. buried due to earthquakes, landslides or other calamities, and are located, marked and identified. Excavations of the surveyed area lead us to the relics, which reflect the history, culture and development of the era. These provide vital links on understanding the evolution of the present civilization as well as human beings.

Route Survey These are undertaken to locate and set out the adopted line on ground for a highway or railway and to obtain all the necessary data. The sequence of operations in a route survey is as follows:

Reconnaissance Survey A visit is made to the site and all the relevant information is collected. It includes collection of existing maps of the area; tracing the relevant map portion over a paper; incorporating the details of the area, if missing, by conducting rough survey.

Preliminary Survey It is the topographical survey of the area in which the project is located. Sometimes an aerial survey is done if the area is extensive. It includes the depiction of the precise locations of all prominent features and fixing the position of the structure on the map.

Control Survey It consists in planning a general control system for preliminary survey which may be triangulation or traversing. For location survey, it consists of triangulation.

Location Survey It consists in establishing the points, exactly on the ground, for which the computations have been done in the control survey for location.

1.5.4 Based on Place of Survey

Land Survey It consists of re-running old land lines to determine their lengths and directions, subdividing the land into predetermined shapes and sizes and calculating their areas and setting monuments and locating their positions (monuments are the objects placed to mark the corner points of the landed property). Topographical, city, and cadastral surveys are some of the examples of land surveying.

Topographical Survey This is a survey conducted to obtain data to make a map indicating inequalities of land surface by measuring elevations and to locate the natural and artificial features of the earth, e.g. rivers, woods, hills, etc.

Cadastral Survey This is referred to extensive urban and rural surveys made to plot the details such as boundaries of fields, houses and property lines. These are also known as public land surveys.

City Survey An extensive survey of the area in and around a city for fixing reference monuments, locating and improving property lines, and determining the configuration and features of the land, is referred to as a city survey. It is similar to the cadastral survey except that refinement observed in making measurements is made proportional to the land cost where the survey is being conducted.

Hydrographic Survey It deals with the survey of water bodies like streams, lakes, coastal waters, and consists in acquiring data to chart the shore lines of water bodies. It also determines the shape of the area underlying the water surface to assess the factors affecting navigation, water supply, subaqueous construction, etc.

Underground Survey This is referred to as preparation of underground plans, fixing the positions and directions of tunnels, shafts and drifts, etc. This consists in transferring bearings and coordinates from a surface base line to an underground baseline. An example of this kind of survey is mine surveying.

Aerial Survey When the survey is carried out by taking photographs with a camera fitted in an aeroplane, it is called aerial or photogrammetric surveying. It is extremely useful for making large-scale maps of extensive constructional schemes with accuracy. Though expensive, this survey is recommended for the development of projects in places where ground survey will be slow and difficult because of a busy or complicated area.

1.6 REQUISITES OF A GOOD SURVEYOR

A good surveyor should have a thorough knowledge of the theory of surveying and skill in its practice. The traits of character and habits of mind are far more potent factors in his success than the technical knowledge. A surveyor should be of sound judgement and reason logically. He should be mild tempered, respectful to his associates, helpful to those working under him and should

watch the interest of the employer. Above all, he should not rely upon the results until the accuracy of the work is established by applying suitable checks. By merely reading books about surveying, a surveyor cannot develop skill and judgement and the probability of him performing a satisfactory survey work is quite low. Proficiency can be attained only by the long continued field practice under the supervision of a professional surveyor.

1.7 PRACTICE OF SURVEYING

Though the theory of plane surveying seems very simple, its practical application is very complicated. Therefore, the training in surveying should be chiefly directed towards a thorough competency in the field methods, associated instruments and office work. A surveying problem can be tackled by different methods of observations and by the use of different suitable instruments. A surveyor must be thorough with the advantages and disadvantages of the different methods of observations and also to the limitations of the instruments. Normally the time and funds are limited. A surveyor's competency, therefore, lies in selecting methods which yield sufficient accuracy to serve the purpose.

1.8 SURVEYING—CHARACTER OF WORK

The work of the surveyor which mainly consists of making measurements can be divided into two parts—field work and office work.

1.8.1 Field Work

For a true representation of the field conditions so as to plot the plans and sections with desired accuracy, sufficient data should be obtained from field work. It consists of adjusting instruments and taking due care of these, making surveying measurements, and recording the measurements in the field note book in a systematic manner.

Adjustments and Care of Instruments The adjustment of a surveying instrument means the bringing of fixed parts of the instrument into proper relation with one another. For this, a surveyor should understand the principles on which adjustments are based, the process by which a faulty adjustment is discovered, the effect of the adjustment on the instrument and the order of the adjustments. Keeping the instruments in adjustment is logical for accurate field work. This necessitates that some parts of the surveying instruments should be adjustable.

A proper care of the instrument keeps it in a fit condition for its usage. Following are a few suggestions to be kept in mind while using the surveying instruments.

- (1) The chain should be checked for its links, rings, and length before its use. All the knots and kinks should be removed by giving gentle jerks while laying it on the field.

- (2) Tape should be kept straight when in use.
- (3) The staff and rod should be either placed upright or supported for the entire length when in use.
- (4) The instrument should be removed from and placed gently in the box.
- (5) The instrument should be protected from vibration and impact.
- (6) The tripod legs should not be set too close together and should be planted firmly on the ground.
- (7) During observation, the surveyor should see to it that the tripod is not disturbed.
- (8) The various clamping and adjusting screws should not be tightened far more than necessary.
- (9) The objective and eye piece lens should not be touched with fingers.
- (10) The dirt and dust should regularly be cleaned from the movable parts of the instrument.
- (11) When the magnetic needle of the instrument is not in use, it should be raised off the pivot.

Surveying Measurements The surveying measurements consists in measuring horizontal and vertical distances, horizontal and vertical angles, horizontal and vertical positions and directions.

The distance between two points measured horizontally throughout is called the *horizontal distance*. If a distance is measured on a slope, it is immediately reduced to the horizontal equivalent by applying suitable corrections. Such a measurement is made with a chain, tape, or by an optical or electronic instrument. The distance measured in the direction of gravity is called *vertical distance* and is equivalent to the difference in height. This measurement is done with an instrument known as level along with a leveling staff.

An angle measured in a horizontal plane at the points of measurement is called a *horizontal angle* and an angle measured in a plane that is vertical at the point of observation, and contains the points, is called a *vertical angle*. Vertical angles are measured upwards or downwards from the horizontal plane. Angles measured upwards are called *plus angles* or angles of elevation and those measured downwards are called *minus angles* or angles of depression. Both the horizontal and vertical angles are measured with an instrument known as transit.

The directions of the courses are expressed as bearings. A bearing is a clockwise horizontal angle from a reference direction, usually north. This is measured with an instrument known as compass.

The relative horizontal position of various points are determined by traverse or by triangulation. A traverse consists of the measurement of a series of horizontal courses (lengths) and the horizontal angles between the courses or the directions of the courses. Triangulation consists of the measurement of the angles of a series of connected triangles and its direction. Both in traversing and triangulation, the final results are computed by trigonometry and are best expressed by rectangular coordinates.

The relative position of the points are determined by a series of level observations with the line of sight being horizontal. The results of leveling are referred to a standard datum, normally mean sea level. The vertical heights above the datum are called elevations. The methods of measurements will be dealt one by one in the subsequent chapters to follow.

Recording Field Notes Field notes are the written records of the field work made at the time the work is done. Records copied from field notes or data recorded afterwards from memory, may be useful, but are not regarded as field notes. A surveyor should keep in mind not only the immediate use of the data, but also those which may be expected to arise in future. Therefore, the field notes must be complete and accurate as far as possible. The importance, accuracy, legibility, integrity, arrangement and clarity that the field notes should have must be over emphasized.

Accuracy All the measurements should be accurate, depending upon the precision desired.

Legibility It should always be kept clearly in mind that the notes may be utilized by someone else who has never even visited the site of the survey. Therefore, all the notes should be legible and contain a professional touch.

Integrity The notes should be complete in all respects before leaving the site of the survey. Even a single omitted measurement may pose a serious problem while computing or plotting in the office.

Arrangement It should be made clear as to how the work began and ended. The note forms should be appropriate to the particular survey and should be arranged in the sequence of the work done in field.

Clarity Sketches and tabulation of field data should be clear and readable. It should be remembered that the notes may be used by someone else in future. Ambiguous notes lead to mistakes in drafting and computation.

Field Book Field notes are usually recorded on standard ruling sheets in a loose-leaf or bound field book. The format of the standard ruled sheet depends upon the type of the instrument used for surveying and is touched upon in detail, in appendices I to IX. However, some general suggestions are presented below.

1. Use a notebook that may stand hard usage.
2. A hard lead pencil, 3H, should be used to record field notes. The reason is that by using a hard pencil, indentations are made on the paper and later, if due to any reason the notes are smeared, the data can still be ascertained by examining the indentations.
3. Erasure should never be made in the field book. If a measured value is recorded incorrectly, it should be cut by a horizontal line and the correct value should be recorded above the cut value.
4. The notes should read from left to right, and from the bottom to top as in the working drawings.

5. The left page of the field book is used for recording data, while the right page is used for sketches.
6. All the calculations and reductions made in the field should be indicated on additional sheets and may be cross-referenced as and when required.
7. On the top of the field notes, names of the survey party, instrument used, data, weather, etc. should be mentioned. This is particularly useful when the field notes are presented as evidence in court.
8. At the end of the day's work, the notes should be signed by the notekeeper.

In recording notes in the field book, a beginner is usually confused whether to book it from the bottom to the top of the page or from top to down. Usually, in making sketch of the course being surveyed, the field book is held with its top towards the next station and if the field notes are recorded on opposite page, it will be convenient to note and read from the bottom up so as to correspond with the sketch. The examples are survey of railways and highways courses. Whereas, when complete sketch is made on one page, such as for a closed traverse, it may be more convenient to tabulate the corresponding notes on the opposite page to read from the top down.

1.8.2 Office Work

It consists of making the necessary calculations or computations for transforming the field measurements into a form suitable for plotting. Knowledge of geometry and plane trigonometry, determining locations, plotting the measurements and drawing a plan or map, inking-in and furnishing the drawings, and calculating areas and volume, all involve office work.

This topic is dealt within detail in the subsequent chapters depending upon the type and method of surveying used for a particular work. Inking-in and furnishing the drawings is described here as it will be a general feature for all types of survey.

Inking-In-Drawings Either inks or water colours may be used. Following are some of the standard colours usually recommended for topographic maps to represent the features.

Black—Lettering and all construction works, e.g. houses, roads, rails, culverts, bridges, etc.

Burnt sienna—All land forms, e.g. streams, lakes, ponds, marshes, etc.

Green—Plantations, e.g. trees, growing crops, grass, etc.

Furnishing Drawings The drawings should be furnished with meridian arrows (Fig. 1.8) of sufficient length, cross-sections, lettering of sufficient size arranged neatly to give a pleasant and artistic look, eye catching titles and symbols. The symbols or conventional signs need a special elaboration as these are used to represent the objects on map. The



Fig. 1.8
Meridian arrows

size of the symbol should be in proportion with the scale of the map. Some of the symbols are shown in Fig. 1.9.













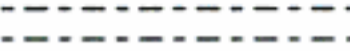

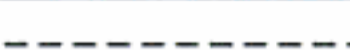
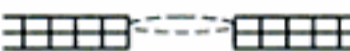
Object	Symbol	Colour
Single Track		Black
Double Track		Black
<i>Pucca</i> Road		Vermilion Red
<i>Kutch</i> a Road		Vermilion Red
Footpath		Vermilion Red
Fencing Post and Rail Fence		Vermilion Red
Tunnel (Road or Rail Road)		Black
Canals and Ditches		Black
Aqueducts and Water Pipes		Black
Dam		Black
Bridge		Black
Stream		Prussian Blue
Pond		Prussian Blue
Falls and Rapids		Black
Road in Embankment		Indian Blue Ink and Road in Vermilion Red
Road in Cutting		Indian Blue Ink and Road in Vermilion Red

Fig. 1.9(a) Conventional symbols

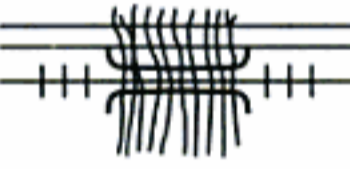



Garden		Indian Black Ink Boundary Chain Dotted and Hopper's Green Wash
Marshy Ground		Indian Black Ink Boundary Chain Dotted and Hooper's Green Wash
Jungle		Indian Black Ink Boundary Chain Dotted and Hooper's Green Wash
Cultivated Land		Green
Orchard		Green
Fence of any kind (or Board Fence)	-----	Black
Barbed Wire Fence	- * * * * *	Black
Smooth Wire Fence	- o - o - o - o -	Black
Rail Fence	~ ~ ~ ~ ~	Black
Hedge Fence	~ ~ ~ ~ ~	Green
Stone Fence	~ ~ ~ ~ ~	Black
Telegraph or Telephone Line	T T T T T T	Black
Power Line	-----	Black
Wall	—————	Vermilion Red
Gate		Vermilion Red

Fig. 1.9(b) Conventional symbols



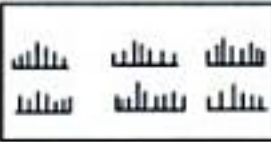



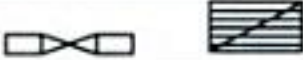

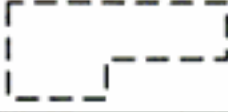
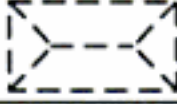

Wall and Gate		Vermilion Red
Building (Large Scale)		Black
Building (<i>Kutch</i> a)		Umber
Huts		Yellow
Temple		Crimson lake
Church		Crimson lake
Mosque		Crimson lake
Benchmark		Black
Open well		Purssina blue
Tube well		Black
Footpath		Black
Metalled road		Burnt sienna
Unmetalled road		Burnt sienna

Fig. 1.9(c) Conventional symbols

1.9 ERRORS

It is understood that every measurement contains errors of unknown magnitude due to several reasons and hence no measurement in surveying is exact. A surveyor should, therefore, understand thoroughly the nature of the sources and behaviour of the errors which may affect the results. A knowledge of the errors and procedures necessary to maintain a required precision aid the surveyor to develop a good judgement in his work.

A true error may be defined as the difference between a measurement and its true value. As the true value of a measurement is never known, the exact error present is therefore never known, and is thus always unknown.

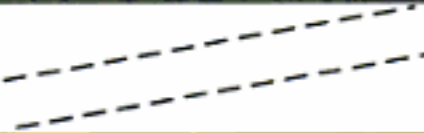
1.9.1 Sources of Error

The sources of error in surveying may be classified as natural, instrumental, and personal.

Natural Errors These result from the temperature, refraction, obstacles to measurements, magnetic declination, etc. For example, the length of a steel tape varies with changes in temperature. Such sources of error are beyond the control of the surveyor, but by taking precautionary measures and adopting suitable methods to fit into the conditions, the errors can be contained within permissible limits.

Instrumental Errors These result from the imperfect construction and adjustment of the instrument. The incorrect graduations of a steel tape and the improper adjustment of the plate levels of a transit are a few examples. The effects of most of the instrumental errors can be brought within the desired limits of precision by applying proper corrections and selecting suitable field methods.

Personal Errors These arise from the limitations of the human senses such as sight, touch, and hearing. For example, improper bisecting of the object by fixing the line of sight of a transit while measuring angles is a personal error.

1.9.2 Types of Errors

Errors in a measurement may be positive or negative. The former occurs if the measurement is too large and the latter if too small. Errors are classified as systematic errors and accidental errors.

Systematic Errors These are the errors which occur from well-understood causes and can be reduced by adopting suitable methods. For example, the error due to sag of a tape supported at ends can be calculated and subtracted from each measurement. However, the tape can be supported throughout its length at short intervals and the sag error may be reduced to a negligible quantity. It always has the same magnitude and sign so long as the conditions remain same and such an error is called constant systematic error. Whereas, if the conditions change, the magnitude of the error changes and this is known as variable systematic error. A systematic error follows a definite mathematical or physical law and, therefore, a correction can always be determined and applied. It is also known as *cumulative error*.

Accidental Errors These are the errors due to a combination of causes and are beyond the control of surveyor. It can be plus or minus. Calibration of a chain is an example of an accidental error.

1.10 DISTINCTION BETWEEN MISTAKE AND ERROR

Mistakes are caused by the misunderstanding of the problem, carelessness or poor judgement. These can be corrected only if discovered. The best way is to compare several measurements of the same quantity and do away with the odd

measurement which does not follow any law. In surveying, attempts are always made to detect and eliminate mistakes in field work and computations. The degree to which a surveyor is able to do this is the measure of reliability. On the other hand, error is defined as the difference of the measured and true value of the quantity. The distinction arises from the fact that mistakes can be avoided by being careful, whereas errors result from sources which can be minimized but not avoided.

1.11 DISTINCTION BETWEEN PRECISION AND ACCURACY

Both precision and accuracy are used to describe physical measurements. The manufacturers, while quoting specifications for their equipments, and surveyors and engineers, to describe results obtained from field work, make use of these terms frequently.

Precision is referred to as the degree of fineness and care with which any physical measurement is made, whereas accuracy is the degree of perfection obtained. It follows that a measurement may be accurate without being precise and vice versa.

Accuracy is considered to be an overall estimate of the errors, including systematic errors present in measurements. For a set of measurements to be considered accurate, the most probable value or sample mean must have a value close to the true value as shown in Fig. 1.10(a).

Precision represents the repeatability of a measurement and is concerned with only random errors. A set of observations that are closely grouped together and have small deviations from the sample mean will have a small standard (probable) error and are said to be precise. It is quite possible for a set of results to be precise but inaccurate as shown in Fig. 1.10(b), where the difference between the true value and the mean value is caused by one or more systematic errors. Since accuracy and precision are the same if all systematic errors are removed, precision is sometimes referred to as internal accuracy.

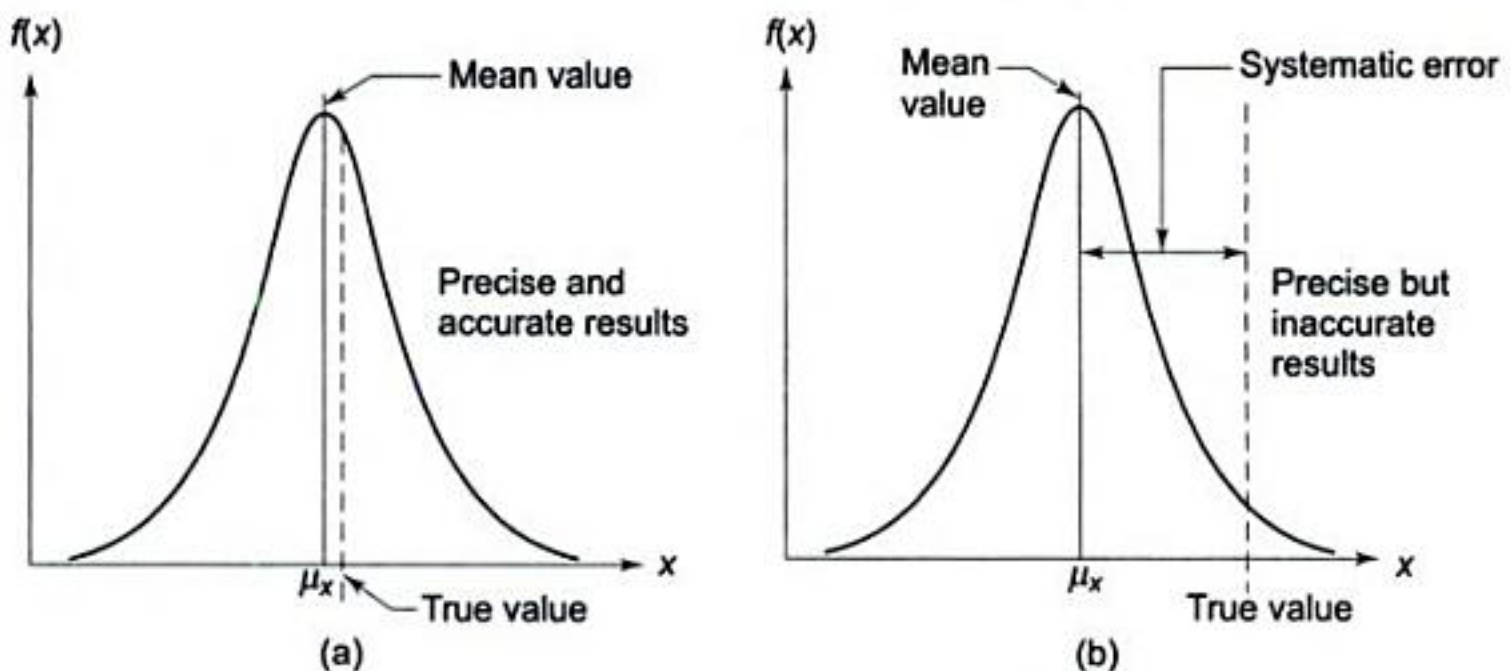

Fig. 1.10 Precision and accuracy

The ratio of precision of a measurement to the measurement itself is termed as relative precision and is expressed as 1 in d/s_d , where d is the measurement and s_d is the standard error. For electromagnetic distance measurement (EDM) instruments and total stations, the relative precision is expressed in parts per million (ppm). The relative precision is normally specified before starting a survey so that proper equipment and methods can be selected to achieve the desired relative precision.

1.12 PLANIMETRIC MAP AND HYPSONETRIC MAP

Planimetric map or line map shows the natural or cultural features in plan only. Whereas, a hypsonetric map presents relief by conventions such as contours, hachures, shading, tinting, etc.

1.13 PENTAGRAPH

It is an instrument used for enlarging, reducing or reproducing the plans.

1.13.1 Construction

It consists of four tubular brass arms square in section. Two of these are long (AB and AC) and are pivoted at one end A (Fig. 1.11). The other two (DE and DF) are short and are hinged together at end D, and are connected to long arms at E and F, having equal sides in all the positions of the instrument. A weight W, known as fulcrum, is attached to long arm AB to fix the frame in a desired position and the instrument moves about this. The instrument is fixed on small rollers to allow free movement on the plan.

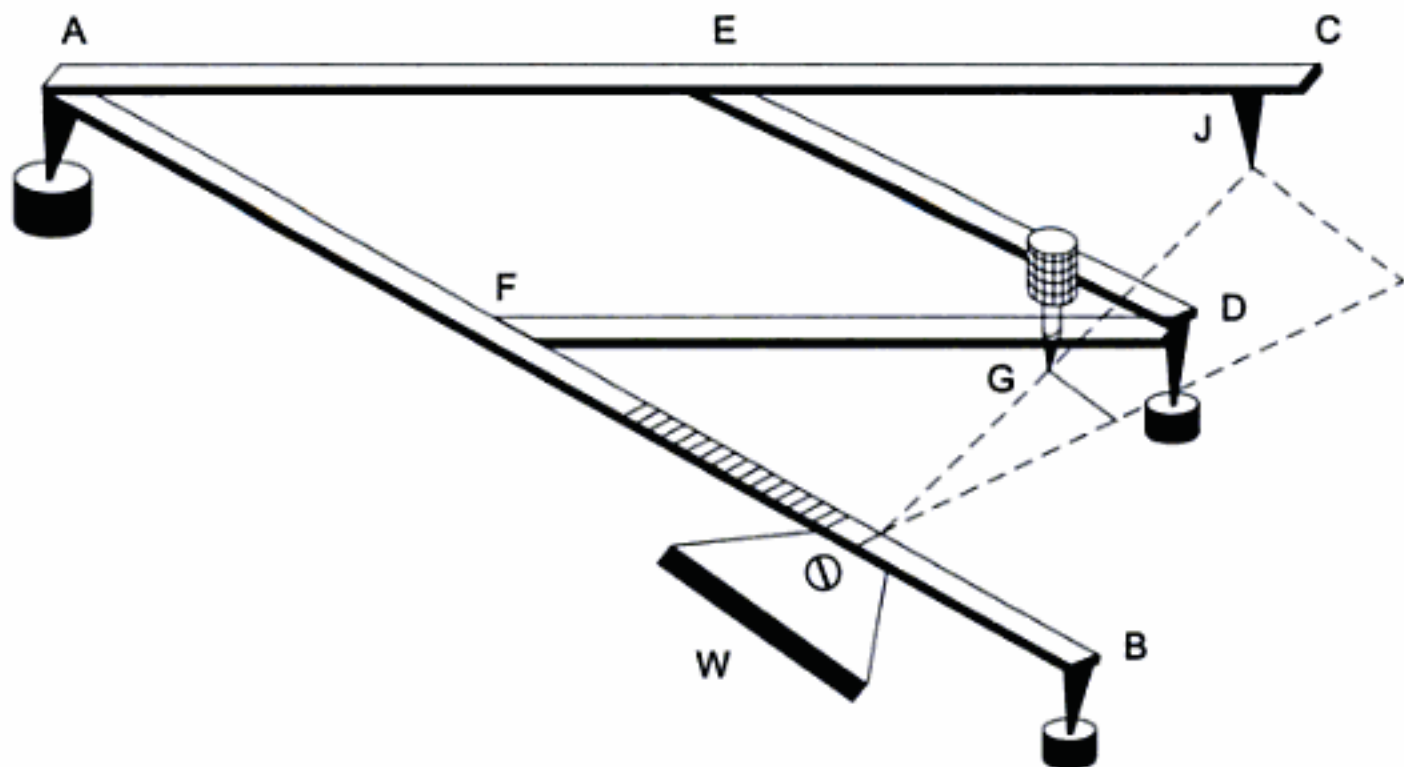

Fig. 1.11 Pentagraph

Arms AB and DF are provided with graduations $1/2$, $1/3$, $1/4$, etc. to give a corresponding enlargement or reduction. Arm AB carries a standing tubular

frame with an index line and a vertical axis of rotation which slides on the arm. The arm DF also carries a frame with an index line and a sliding pencil. Both these frames can be clamped at any division with the respective clamping screw. In Fig. 1.11 points C and G are the tracing point and pencil point, respectively. The instrument in this position is used for reduction. These two points are interchangeable. When G is used as tracing point and C as pencil point, the instrument can be used for enlargement. The arm AC, carrying a tracing point at C, when moved over the boundary of the plan with the pencil fixed at G, produces the desired reduced scale copy.

The instrument is very suitable for reductions but for enlargements the results are not satisfactory.

1.13.2 Principle

The working of the pentagraph is based on the principle of similar triangles. Let AB and AC be two straight arms hinged at A. E and F are two points on the respective arms equidistant from A (Fig. 1.12). AFDE is a parallelogram. Let AC be hinged at J and the end B moved. The movement of points G and J will be in the ratio of their distances from F and E, respectively.

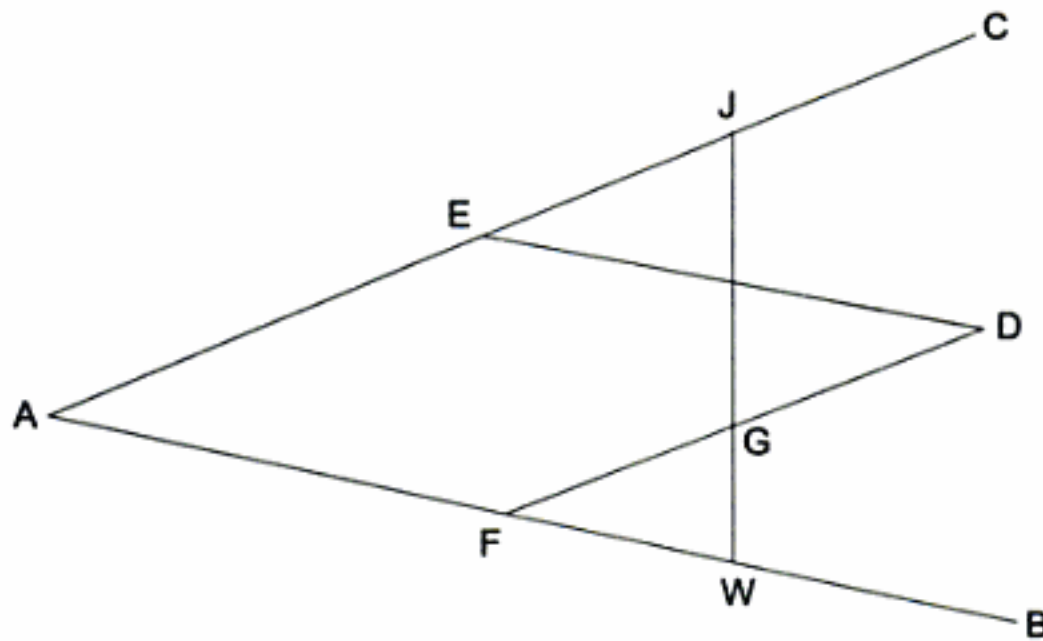

Fig. 1.12

ADEF is a parallelogram. Hence, FG is parallel to AE.

Also $\angle GFB = \angle BAC$

WGF and WJA are similar triangles.

Hence,
$$\frac{WG}{WJ} = \frac{FW}{AW}$$

Any displacement of J will give a corresponding displacement of G through FW/AW and hence the plan placed at J will be reduced.

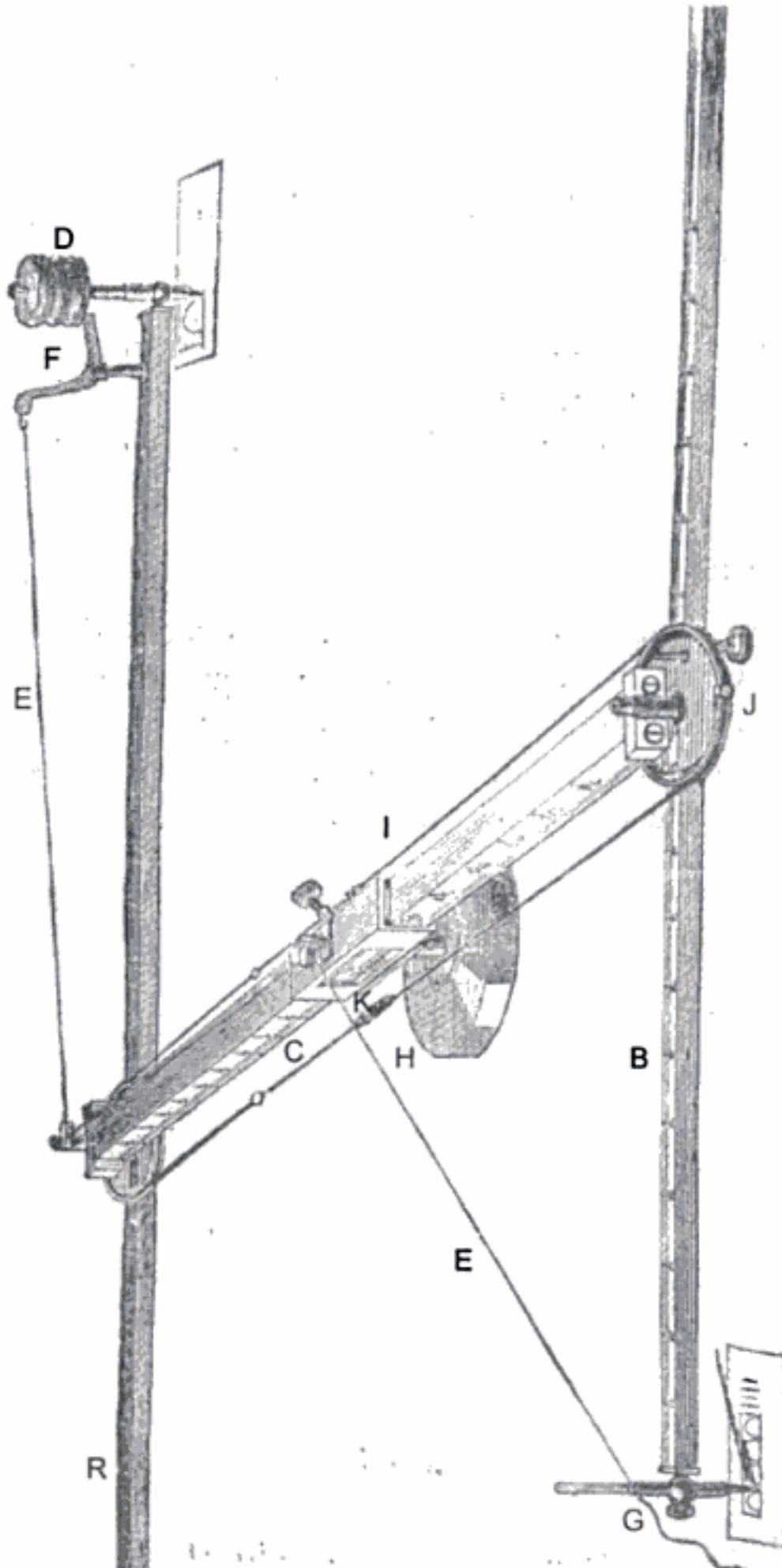

Fig. 1.13 Eidograph

1.14 EIDOGRAPH

The eidograph is also used for the same purposes as the pentagraph. The pentagraph requires four supports on the paper and has numerous joints; its action is apt to be unsteady. In contrast, eidograph has only one support upon which the entire instrument moves steadily and regularly. All the joints of the

eidograph consist of fulcrums fitting in accurately ground bearings, the motion around these fulcrums being capable of adjustment for regularity as well as accuracy. Further, an eidograph may be set to form a reduced copy bearing any required proportion to the original, while a pentagraph can be set for only few proportions specifically marked on it.

1.14.1 Construction

Figure 1.13 shows the constructional details of an eidograph. The heavy weight (H) of the eidograph is formed by lead with brass covering. It has three or four needle-points to keep it steady on the paper. The pin, forming the fulcrum upon which the whole instrument moves, projects from the centre of this weight on its upper side, and fits into a socket attached to sliding box (K). The centre beam (C) fits into and slides through the box, and can be adjusted to any desired position with respect to the fulcrum. It can be fixed by a clamping screw attached to the box. The centre pins of the pulley-wheels (J) are fitted into the deep sockets attached to each end of the centre beam. The pulley wheels have two steel bands (I) attached to their circumference, so that they can move only simultaneously, and to exactly the same amount. By means of screw adjustments these bands can have their lengths regulated so as to bring the arms of the instrument into exact parallelism and, at the same time, to bring them to such a degree of tension so as to provide the motions of the arms with the required steadiness, which forms one of the advantages of the instrument over the pentagraph. The arms, A and B, of the instrument pass through sliding boxes upon the under side of the pulley-wheels; these boxes, like that for the centre beam, being fitted with clamping-screws, by which the arms can be fixed in any desired position. At the end of one of the arms is fixed a socket with clamping-screw, to carry a tracing-point, G, and at the end of the other is a socket for a loaded pencil, D, which may be raised when required by a lever, F F, attached to a cord which passes over the centre of the instrument to the tracing-point. The centre beam, C, and the arms, A and B, are made of square brass tubes, divided exactly alike into 200 equal parts, and figured so as to read 100 each way from their centres. The boxes through which they slide have verniers, by means of which these divisions may be subdivided into 10, so that with their help, the arms and beam may be set to any reading containing not more than three places of figures. A loose leaden weight is supplied with the instrument to fit on any part of the centre beam, and keep it in even balance when set with unequal lengths of the centre beam on each side of the fulcrum.

1.14.2 Principle

The pulleys being of exactly equal size, when the steel bands are adjusted so as to bring the arms of the instrument into exact parallelism, they will remain parallel throughout all the movements of the pulleys in their sockets, and thus will always make equal angles with the centre beam. If, then, the two arms and the centre beam are all set so that the readings of their divisions are the same, a

line drawn from the end of one arm across the fulcrum to the end of the other arm will form, with the beam and arms, two triangles having their sides about equal angles proportionals, and being, therefore, similar. Hence any motion communicated to the end of one arm will produce a similar motion at the end of the other, so that the tracing-point being moved over any figure whatever, an exactly similar figure will be described by the pencil.

Suppose it is required to set the instrument so that the proportion of the copy to the original be $a : b$. Let x be the reading to which the instrument should be set, then the centre beam and arms are each divided at their fulcrums into portions whose lengths are $100 - x$ and $100 + x$, respectively consequently,

$$(100 - x)/(100 + x) = a/b$$

$$\Rightarrow x = 100 (b - a)/(b + a)$$

Thus, if the proportions are $1 : 2$, we have $x = 100 (2 - 1)/(2 + 1) = 33.3$

The instrument must be set with the third divisions of the verniers beyond the indices and the third divisions of the instrument beyond the 33rd. The readings to which the instrument must be set for given proportions is given in Table 1.1.

Table 1.1

Proportions	1 : 2	1 : 3	1 : 4	1 : 5	1 : 6	2 : 3	2 : 5	3 : 4	3 : 5
Readings	33.3	50	60	66.7	71.4	20	42.9	14.3	25

When the copy is to be reduced, the centre beam is to be set to the reading found, as above, on the side of the zero next to the arm carrying the pencil-point, and this arm is also to be set to the same reading on the side of its centre or zero nearest to the pencil-end, while the tracer-arm is to be set with the reading farthest from the tracer. When the copy is to be enlarged, these arrangements must of course be reversed.

Figure 1.14 represents the setting which makes the linear dimensions get reduced to one-fourth (Fig. 1.14(a)) and get enlarged to four times (Fig. 1.14(b)). For proportion $1 : 4$, the reading to be set is 60. P represents the position of the pencil point, T that of the tracer, and F the place of the fulcrum.

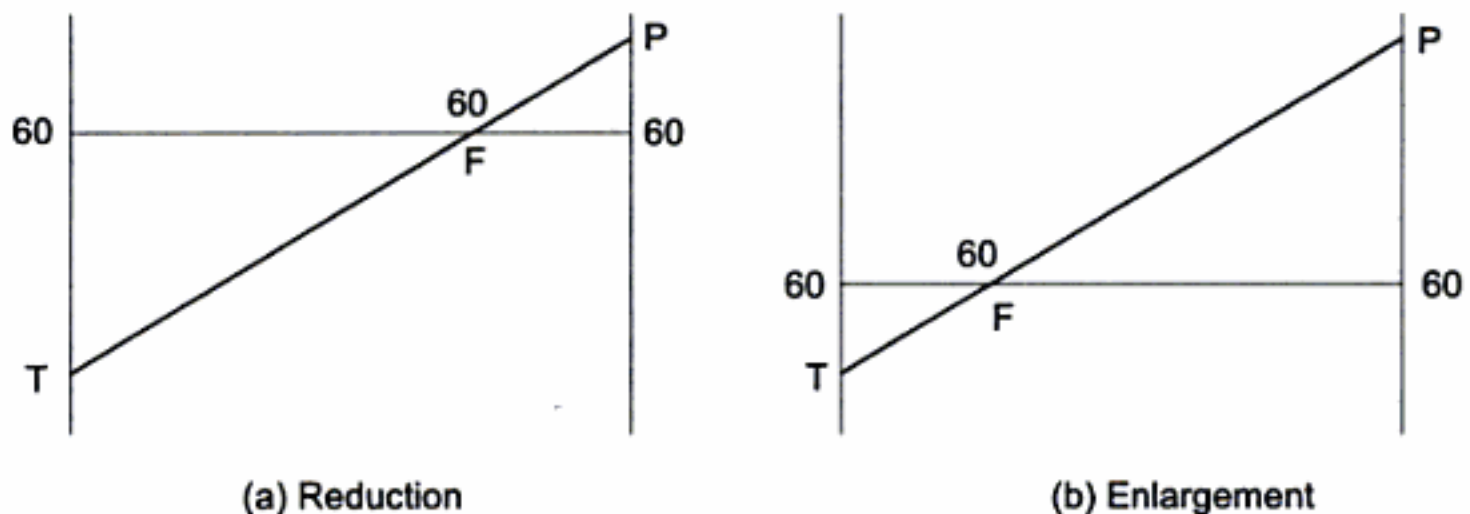

Fig. 1.14 Reducing/enlarging drawings ($1 : 4$)

1.15 UNITS OF MEASURE

The system of units used in India in the recent years is M.K.S. and S.I. But all the records available in surveying done in the past are in F.P.S. units. Therefore, for a professional it becomes necessary to know the conversion of units from one system to another, a few of which are listed below and many more can be computed.

1 ft	= 0.3048 m
1 mile	= 5280 ft
1 yard	= 3 ft
1 mile	= 1.609 km
1 sq mile	= 2.590 km ²
1 sq mile	= 640 acres
1 acre	= 43,560 sq ft
1 hectare	= 2.471 acres

Exercises

1.1 Define and differentiate the following:

- (i) Plan and map (ii) Error and mistake
 (iii) Accuracy and precision (iv) Plane and Geodetic surveys

1.2 Convert the following representative fractions into scales.

- (i) 1/100,000 (ii) 1/1,000,000
 (iii) 1/20,000

[Ans. 1 cm = 1 km, 1 cm = 10 km, 1 cm = 0.20 km]

1.3 A rectangular piece of property has sides measuring 300 m and 200 m. What is the area of the property in square metres, square kilometres, acres, hectares?

[Ans. 6×10^4 , 6×10^{-2} , 4.820, 6.0]

1.4 What information should be included in a good set of field notes?

1.5 Briefly discuss the requirements of good field notes.

1.6 Briefly discuss the following:

- (i) Earth's surface (ii) Level surface
 (iii) Great circle (iv) Plumb line

1.7 Define surveying. What are the principles of surveying? Explain them briefly.

1.8 Write short notes on the following:

- (i) Geodetic survey (ii) Defence survey
 (iii) Mine survey (iv) Cadastral survey
 (v) Aerial survey

1.9 Draw symbols for the following:

- (i) Cemetery (ii) Mosque
 (iii) Barbed wire (iv) Triangulation station
 (v) Culvert

- 1.10 Discuss briefly the different types and sources of errors in surveying.
- 1.11 Explain the principle and working of pentagraph with the help of neat sketches.
- 1.12 Explain the construction and principle of working of eidograph.

Objective-type Questions





- 1.1 Surveying is the art of determining the relative positions of points on, above or beneath the surface of the earth, with respect to each other, by the measurement of
- (i) distances (ii) directions (iii) elevations
- (a) (i), (ii), (iii) are required (b) only (i) is required
- (c) only (ii) required (d) only (iii) is required
- 1.2 The main principle of surveying is to work from
- (a) higher level to the lower level
- (b) lower level to the higher level
- (c) part to whole
- (d) whole to part
- 1.3 The error which occurs while conducting the survey from whole to part and part to whole is
- (a) same
- (b) in whole to part, it is localized and in part to whole it is expanded
- (c) in whole to part it is expanded and in part to whole it is localized
- (d) in both the methods error is localized
- 1.4 A point R can be located by the two control points P and Q by
- (i) measuring PR and QR from P and Q, measure distance of R and plot
- (ii) dropping a perpendicular from R on PQ, meeting the line in S, measure PS, SQ and plot
- (iii) distance QR and angle α between QR and QP
- (a) only (i) is correct
- (b) by (i) and (ii) both
- (c) by (i), (ii) and (iii)
- (d) by none of them
- 1.5 The objective of a survey is to
- (i) prepare a plan or map
- (ii) determine the relative position of points
- (iii) determine position of points in a horizontal plane
- (iv) determine position of points in a vertical plane
- (a) only (i) is correct
- (b) only (i) and (ii) are correct
- (c) (i), (ii), (iii), (iv) all are correct
- (d) none of them are correct

- 1.6 The difference in the length of an arc and its subtended chord on earth's surface for a distance of 18.5 km is about
 (a) 0.1 cm (b) 1.0 cm
 (c) 10 cm (d) 100 cm
- 1.7 Surveys which are carried out to provide a national grid of control for preparation of accurate maps of large areas are known as
 (a) Plane surveys (b) Geodetic surveys
 (c) Geographical surveys (d) Topographical surveys
- 1.8 Surveys which are carried out to depict mountains, water bodies, woods and other details are known as
 (a) Cadastral surveys (b) City surveys
 (c) Topographical surveys (d) Hydrographic surveys
- 1.9 Hydrographic surveys deal with the mapping of
 (a) heavenly bodies (b) hills
 (c) large water bodies (d) canal system
- 1.10 Plan is a graphical representation of the features on large scale as projected on a
 (a) horizontal plane (b) vertical plane
 (c) in any plane (d) none of the above
- 1.11 Map is a graphical representation of the features on small scale as projected on a
 (a) horizontal surface (b) vertical surface
 (c) in any surface (d) none of the above
- 1.12 The survey in which the curvature of the earth is taken into account is called
 (a) Geodetic survey (b) Plane survey
 (c) Preliminary survey (d) Hydrographic survey
- 1.13 The effect of the curvature of the earth's surface is taken into account only if the extent of survey is more than
 (a) 100 km^2 (b) 260 km^2
 (c) 195.5 km^2 (d) 300 km^2
- 1.14 Plane survey is conducted for the area up to
 (a) 260 km^2 (b) 100 km^2
 (c) 195.5 km^2 (d) 160 km^2
- 1.15 The difference between the sum of the angles of a spherical triangle on the earth's surface to that of the angles of the corresponding plane triangle is only one second for every
 (a) 260 km^2 (b) 160 km^2
 (c) 360 km^2 (d) 195.5 km^2
- 1.16 The following are the subdivisions of engineering survey. Match them.
 (I) Reconnaissance survey (A) To determine feasibility and rough cost of the scheme.
 (II) Preliminary survey (B) To collect more precise data, to choose the best location for the work and to estimate the exact quantities and costs.

- (III) Location survey
- (a) I–A, II–B, III–C
(c) I–C, II–A, III–B
- 1.17 Match the following:
- (I) Topographical survey
- (II) Cadastral survey
- (III) City survey
- (IV) Engineering survey
- (C) For setting out the work on the ground.
(b) I–B, II–A, III–C
(d) I–B, II–C, III–A
- (A) To determine the natural features of a country such as hills, valleys, rivers, nuallas, lakes, woods, etc.
- (B) To survey for the features such as roads, railways, canals, buildings, towns, villages, etc.
- (C) To locate the boundaries of fields, houses, etc.
- (D) To determine quantities and for collection of data for road, railways, reservoirs, sewerage, water supply scheme, etc.
- (E) For laying out plots and construction streets, water supply systems and sewers.
- (a) I–A and B, II–C, III–E, IV–D
(b) I–C, II–A and B, III–C, IV–E
(c) I–D, II–A and B, III–C, IV–E
(d) I–B, II–C, III–A, IV–D and E
- 1.18 Systematic errors are those errors
- (a) which cannot be recognized
(b) whose character is not understood
(c) whose effects are cumulative and can be eliminated by adopting suitable methods
(d) which change rapidly
- 1.19 Theory of probability is applied to
- (a) accidental errors only
(b) cumulative errors only
(c) both accidental and cumulative
(d) none of the above
- 1.20 The error due to bad ranging is
- (a) cumulative (+ve) (b) cumulative (–ve)
(c) compensating (d) cumulative (+ve or –ve)
- 1.21 The difference between the most probable value of a quantity and its observed value is
- (a) true error (b) weighted observation
(c) conditional error (d) residual error

- 1.22 Which of the following scales is the largest one
 (a) 1 cm = 50 m (b) 1 : 42 000
 (c) RF = 1/300 000 (d) 1 cm = 50 km
- 1.23 Mistakes are errors which arise from
 (i) lack of attention (ii) carelessness
 (iii) poor judgment (iv) confusion
 (a) only (i) is correct
 (b) (i), (ii) are correct
 (c) (i), (ii), (iii), (iv) all are correct
 (d) none of them is correct
- 1.24 Errors are of same size and sign of mistakes, if it follows some definite
 (i) mathematical law (ii) physical law
 (a) (i) and (ii) are correct (b) only (i) is correct
 (c) only (ii) is correct (d) none is correct
- 1.25 The shrinkage factor of an old map is $24/25$ and the RF is $1/2400$, then the corrected scale for the map is
 (a) $1/2400$ (b) $1/2500$
 (c) $1/600$ (d) $1/60\ 000$
- 1.26 The RF of scale 1 cm = 1 km is
 (a) $1/100\ 000$ (b) $1/1000$
 (c) $1/100$ (d) $1/10$
- 1.27 The degree of precision required in survey work mainly depends upon the
 (a) purpose of survey (b) area to be surveyed
 (c) sources of error (d) nature of the field
- 1.28 Match the following:
- | Type of map | Scale |
|------------------------|--------------------------|
| (I) Geographical map | (A) 1 cm = 160 km |
| (II) Topographical map | (B) 1 cm = 2.5 km |
| (III) Location map | (C) 1 : 2500 to 1 : 500 |
| (IV) Forest map | (D) 1 : 2500 |
| (V) Cadastral map | (E) 1 : 1000 to 1 : 5000 |
- (a) I–A, II–B, III–C, IV–D, V–E
 (b) I–B, II–A, III–C, IV–D, V–E
 (c) I–C, II–D, III–E, IV–A, V–B
 (d) I–E, II–B, III–D, IV–B, V–A
- 1.29 It is convenient to record the field notes for a closed traverse in the field book
 (a) from left to right (b) from right to left
 (c) from top to down (d) from bottom to top
- 1.30 The smallest length that can be drawn on a map is
 (a) 0.2 mm (b) 0.5 mm
 (c) 10 mm (d) 15 mm
- 1.31 Which of the following instrument(s) is (are) used for enlarging or reducing the drawings

- (i) pentagraph (ii) eidograph
 (a) (i) only (b) (ii) only
 (c) both (i) and (ii) (d) none of the above
- 1.32 Suppose a drawing is to be reduced by a proportion 4 : 5, the reading to which the instrument should be set will be
 (a) 50 (b) 60 (c) 14.3 (d) 11.1
- 1.33 Match List I with List II and select the correct answer using the codes given below the lists:

List I (Object)	List II (Symbol)
(a) Hedge	(1) 
(b) Wire fencing	(2) 
(c) Pipe fencing	(3) 
(d) Wood fencing	(4) 

Codes

(a) A	B	C	D
1	2	3	4
(b) A	B	C	D
4	2	3	1
(c) A	B	C	D
1	2	4	3
(d) A	B	C	D

- 1.34 A hut can be shown by the symbol



- 1.35 The symbol  represents

- (a) Temple (b) Mosque
 (c) Church (d) Hut

— Answers to Objective-type Questions —

- | | | | | |
|----------|----------|----------|----------|----------|
| 1.1 (a) | 1.2 (d) | 1.3 (b) | 1.4 (c) | 1.5 (c) |
| 1.6 (b) | 1.7 (b) | 1.8 (c) | 1.9 (c) | 1.10 (a) |
| 1.11 (a) | 1.12 (a) | 1.13 (c) | 1.14 (c) | 1.15 (d) |
| 1.16 (a) | 1.17 (a) | 1.18 (c) | 1.19 (a) | 1.20 (a) |
| 1.21 (d) | 1.22 (a) | 1.23 (c) | 1.24 (a) | 1.25 (b) |
| 1.26 (a) | 1.27 (a) | 1.28 (a) | 1.29 (c) | 1.30 (a) |
| 1.31 (c) | 1.32 (d) | 1.33 (a) | 1.34 (d) | 1.35 (c) |

Chapter 2

Horizontal Measurements



2.1 INTRODUCTION

History reveals that the measurement of horizontal distance has taken a variety of forms with marked variations in the accuracies achieved. Various methods such as rope stretching, bamboo, pacing, chaining, optical (tacheometry) and electromagnetic distance measurement exist, varying from the crude to the highly sophisticated ones. The cost of making a measurement increases with the desired precision of the work. Therefore, it is important to know the methods available and their accuracies so as to obtain the required precision with economy.

Measurement of horizontal distance is probably the most basic operation performed in surveying and perhaps the most difficult as well. The horizontal distance between two points is the distance between the plumb lines through the points. It is important to emphasize that in plane surveying, the distances measured should be horizontal. When distances are measured on slopes, sufficient data should be collected so as to compute horizontal projections.

Rope stretching and bamboo measurements are very crude methods and are obsolete. Pacing can be recommended if an error of 5% is permissible and if the ground is flat.

In the optical methods, principles of optics are used. The distances are not actually measured in field but are computed indirectly by using the principles of optics. The instrument used for making observations is called tacheometer. Tacheometry may be employed when the ground is rough, undulating and not suitable for chaining.

The electromagnetic distance measurements can be made by using light waves or radio waves. The instruments used in the former case are called Geodimeter and Makometer, whereas distomat uses radio waves.

Electronic methods and aerial photogrammetry yield results with high precision but are expensive.

The most common method of measuring the distances is by the use of chain and tape. This operation is called chaining irrespective of whether a chain or a tape is used. Chaining is recommended for moderately small areas and measurement of ill-defined details, e.g. edge of a marsh or for filling in details between already established control points. Chain is used to measure the lengths of the line and tape is employed to measure the perpendicular distances to the chain line, called offsets. In the process of chaining, the survey party consists of a leader (the surveyor at the forward end of the chain), a follower (the surveyor at the rear end of the chain) and an assistant to establish intermediate points.

The accuracy to which measurements can be made with chain and tape varies with the methods used and the precautions exercised. The precision of chaining for ordinary work ranges from 1/1000 to 1/30 000 and precise measurements such as baseline may be of the order of 1 000 000.

Good chaining and standardized and adjusted chain in good order may be expected to give an accuracy of 1/500 to 1/1 000 000. Accuracy in the base measurement seldom exceeds 1/500 000.

The scope of the chapter limits the study of various methods of horizontal measurements to that of chain and tape.

2.2 CHAIN SURVEYING

It is the branch of surveying in which the distances are measured with a chain and tape and the operation is called chaining. All the distances measured should be horizontal. However, if measured on slopes, the measurements are to be subsequently reduced to horizontal equivalents. To have a better understanding of chain surveying, a few terms need explanation. Here reference may be made to Fig. 2.1.

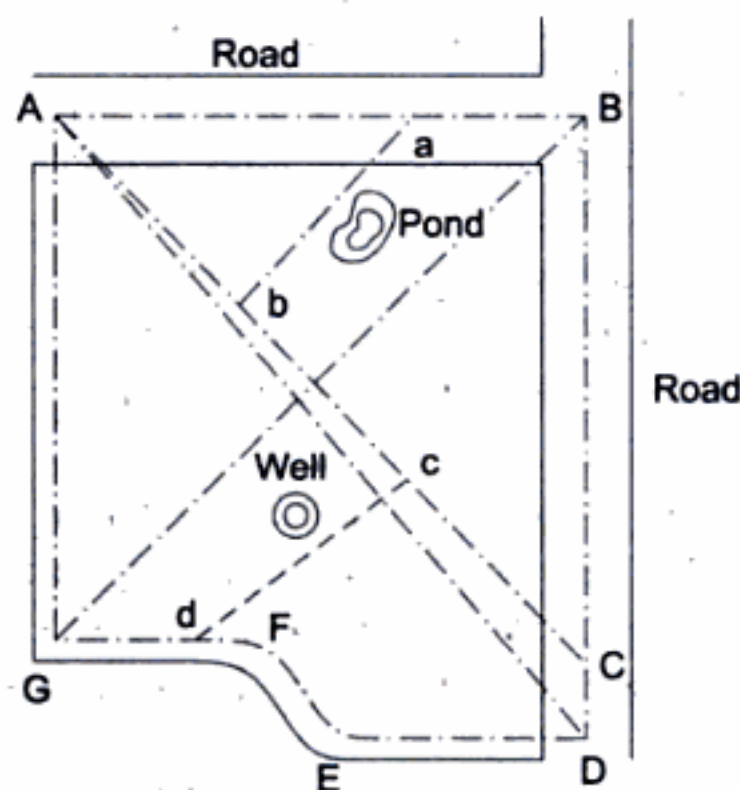

Fig. 2.1

Main Station Main station is a point in chain survey where the two sides of a traverse or triangle meet. These stations command the boundaries of the survey and are designated by capital letters such as A, B, C, etc.

Tie Station or Subsidiary Station Tie station is a station on a survey line joining two main stations. These are helpful in locating the interior details of the area to be surveyed and are designated by small letters such as a, b, c, etc.

Main Survey Line The chain line joining two main survey stations is called main survey line. AB and BC are examples of main survey lines.

Tie Line or Subsidiary Line A chain line joining two tie stations is called tie line such as ab or cd. It is also called auxiliary line. These are provided to locate the interior details which are far away from the main lines.

Base Line It is the longest main survey line on a fairly level ground and passing through the centre of the area. It is the most important line as the direction of all other survey lines are fixed with respect to this line.

Check Line Check line or proof line is a line which is provided to check the accuracy of the field work. The measured length of the check line and the computed one (scaled off the plan) must be the same. AD is an example of check line.

Offset It is the distance of the object from the survey line. It may be perpendicular or oblique.

Chainage It is the distance of a well-defined point from the starting point. In chain surveying it is normally referred to as the distance of the foot of the offset from the starting point on the chain line. The operation of measuring the distance is termed as chaining/taping.

Field Work in Chain Survey

Suppose a plan is required for a small area as shown in Fig. 2.1. The surveyor should first of all thoroughly examine the ground to ascertain as to how the work can be arranged in the best possible manner. This is known as reconnaissance. In this process, the surveyor selects suitable ground points to be used as stations like A, B, or C, etc.

Stations are arranged so that the entire area may be controlled from these and all the main survey lines, e.g. AB, BC, CD, etc. run near to the boundaries. The survey lines should not be many and lie over flat level ground as far as possible. The triangles formed by survey lines should be well conditioned.

The main survey lines are measured with a chain and offsets are taken to the crooked boundaries. offsets are taken wherever there is a bend or any special feature in the boundary. In the case where the boundary forms a smooth curve, offsets are taken at the end of each chain. Offsets should be short particularly for locating important details.

The lengths and positions of offsets being known, the boundaries can be plotted to their shapes. The other details, which are deep inside the area such as a pond or well as shown in Fig. 2.1, can be located by selecting tie stations, drawing tie lines and taking offsets to the ground features. The equipments and accessories required for chaining are described in the following sections.

2.3 CHAIN

Gunter, revenue, engineer and metric chain are the various types of chains which are normally used for surveying. The chains are mostly divided into 100 links. While Gunter's chain is 66 ft long (100 links), the revenue chain is 33 ft long (16 links) and the engineer's chain is 100 ft long (100 links). Metric chains are either 30 m (150 links) or 20 m (100 links) in length. The constructional detail of metric chain are presented in details as it is generally used for the routine measurement of distances.

Metric Survey Chain (20 m or 30 m)

A metric chain (Fig. 2.2) divided into 100 links is made of galvanised mild steel wire 4 mm in diameter. The ends of each link are bent into loops and connected together by means of three oval rings, which afford flexibility, to the chain. The length of the link is the distance between the centres of the two consecutive middle rings. The ends of the chain are provided with brass handles with swivel joint, so that the chain can be turned round without twisting. The outside of the handle is the zero point or the end point of chain. The length of the chain is measured from outer end of the handles. Metallic tags are used at 5, 10, 15, 20, 25 m (Fig. 2.3) intervals for quick reading. The metallic tags used are called tallies. Small brass rings (Fig. 2.3(a)) are provided at every metric length except at 5, 10, 15, 20 m, etc. The handles of the chain are provided with grooves so that the arrows can be held at the correct positions.

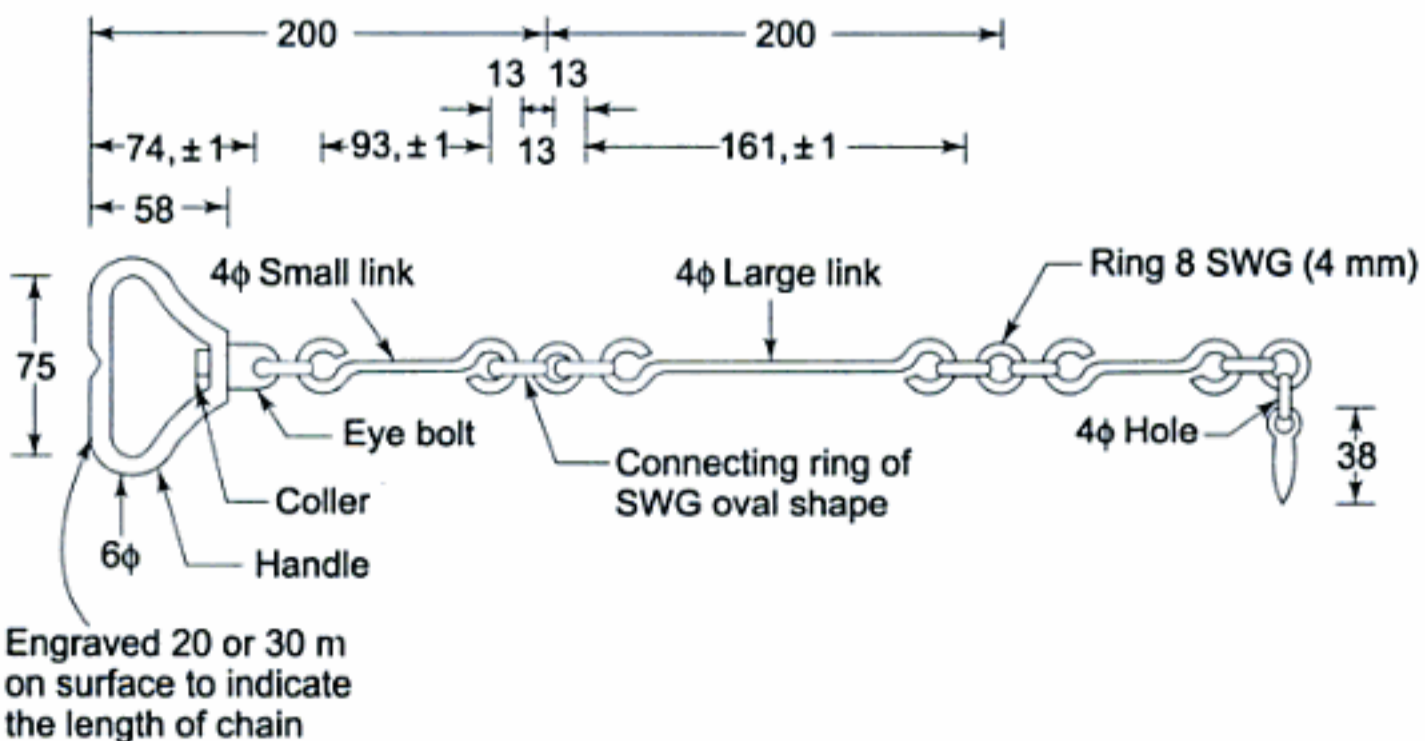

Fig. 2.2 Details of metric chain

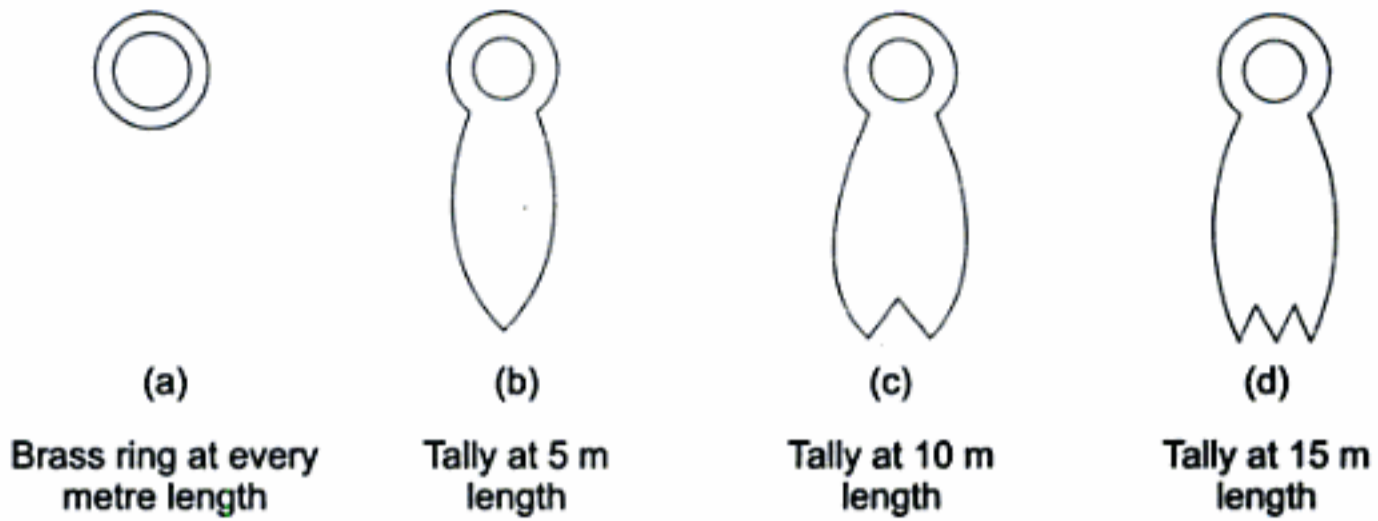

Fig. 2.3 Ring and tallies of a chain

Suitability of Chain

1. It is suitable for rough use only.
2. It can be easily repaired in field.
3. It can be read easily.

Unsuitability of Chain

1. Being heavier, it sags considerably when suspended in air.
2. Its length alters by shortening/lengthening of links. Therefore, it is suitable for ordinary work only.

Unfolding the Chain (undoing the chain) The leather strap is removed and with both the handles of the chain in the left hand the chain is thrown well forward with the right hand. The leader then takes one of the handles of the chain and moves forward until the chain is extended to full length. The chain is checked and kinks of bent links are removed.

Folding the Chain (doing the chain) The chain is pulled from the middle and the two halves of the chain are so placed as to lie alongside each other. Commencing from the middle, two pairs of links are taken at a time with the right hand and are placed obliquely across the others in the left hand. The chain is then folded into a bundle and fastened with a leather strap.

Testing of Chain During its use, the links of a chain get bent and the length is shortened. On the other hand, the length of a chain may increase by stretching of links and usage, and rough handling through hedges, fences, etc. Therefore, it becomes necessary to check the length of the chain before commencing the survey work. Before checking, it should be ensured that its links are not bent, rings are circular, openings are not too wide and mud is not clinging to them.

Specification When a tension of 80 N is applied at the ends of the chain and compared against a certified steel band (tape), standardized at 20°C, every metre length should be accurate to within ± 2 mm. The accuracy of an overall length of 20 m chain should be within ± 5 mm and that of a 30 m chain within ± 8 mm.

Procedure Two pegs at a required distance of 20 or 30 m are inserted on a flat ground (Fig. 2.4). The overall length of the chain is compared with the marks and the difference is noted.

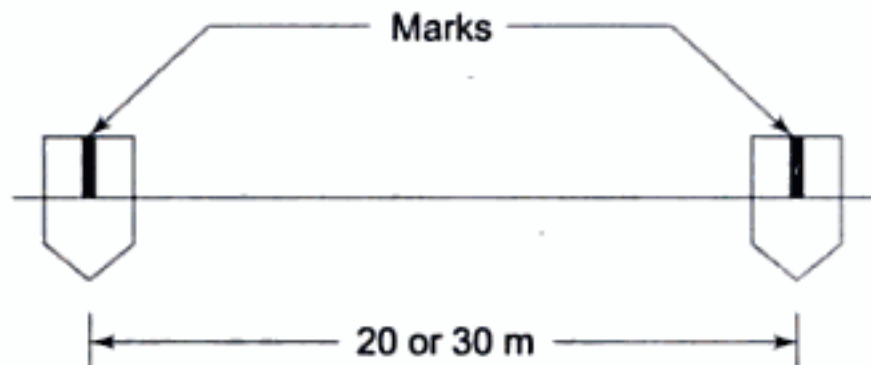

Fig. 2.4 Testing 20/30 chain

If the chain is found to be too long, it may be adjusted by closing the opened joints of rings; reshaping the elongated links; removing one or more circular rings; and replacing the worn out rings. If chain is found too short, it may be adjusted by straightening the bent links; flattening the circular rings; replacing circular rings by bigger rings; and inserting additional rings.

2.4 TAPES

Tapes are available in a variety of materials, lengths and weights. The different types of tapes used in general are discussed below.

Cloth or Linen Tape These are closely woven linen or synthetic material and are varnished to resist the moisture. These are available in lengths of 10–30 m and widths of 12–15 mm. The disadvantages of such a tape include: (1) it is affected by moisture and gets shrunk; (2) its length gets altered by stretching; and (3) it is likely to twist and does not remain straight in strong winds.

Metallic Tape It is a linen tape with brass or copper wires woven into it longitudinally to reduce stretching. As it is varnished, the wires are not visible. These are available in lengths of 20–30 m. It is an accurate measurement device and is commonly used for measuring offsets. As it is reinforced with wires, all the defects of linen tapes are overcome.

Steel Tapes These are 1–50 m in length and are 6–10 mm wide. At the end of the tape a brass ring is attached, the outer end of which is zero point of the tape. Steel tape cannot be used in ground with vegetation and weeds.

Invar Tape This is made of an alloy of nickel (36%) and steel, having very low coefficient of thermal expansion ($0.122 \times 10^{-6}/^{\circ}\text{C}$). These are available in lengths of 30, 50 and 100 m and in a width of 6 mm. The advantages and disadvantages of an invar tape are as follows:

Advantages

1. Highly precise.
2. It is less affected by temperature changes when compared to the other tapes.

Disadvantages

1. It is soft and so deforms easily.
2. It requires much attention in handling.

2.5 ACCESSORIES FOR CHAINING

In addition to the equipments (chains and tapes), accessories, e.g. pegs, arrows, ranging rods, offset rods and plumb bob are required for chaining operations.

2.5.1 Pegs

These are used to mark definite points on the ground either temporarily or semi-permanently. The exact point to and from which the measurements are to be taken, or over which an instrument is to be set, is often necessary to indicate on a peg. For this, a nail or a brass stud is driven into the flat top of the peg. The size of a peg depends on the use to which the pegs are to be put and the nature of the ground in which they are to be driven. Generally, hard creosoted wood 2.5–7.5 cm² and 15–90 cm long, flat at one end and pointed at the other end are used. For temporary use, pegs of nearly round section are cut from the standing trees and then are pointed at one end and flattened at the other end. Iron or tubular pegs are made of cut pieces of about 1–2 cm in diameter. Though expensive and troublesome to carry, these pegs are preferred since they last longer.

For permanent marking of stations, a small concrete pillar is used as a peg. The size varies from 15 to 30 cm² and 7.5 to 60 cm in height and is built *in situ*.

2.5.2 Arrows

These are also known as *chaining pins* and are used to mark the end of each chain during the chaining process. These are made of hardened and tempered steel wire 4 mm in diameter. The length of an arrow is kept at 400 mm. These are pointed at one end whereas a circular ring is formed at its other end, as shown in Fig. 2.5, to facilitate carrying from one station to another. As the arrows are placed in the ground after every chain length, the number of arrows held by the follower

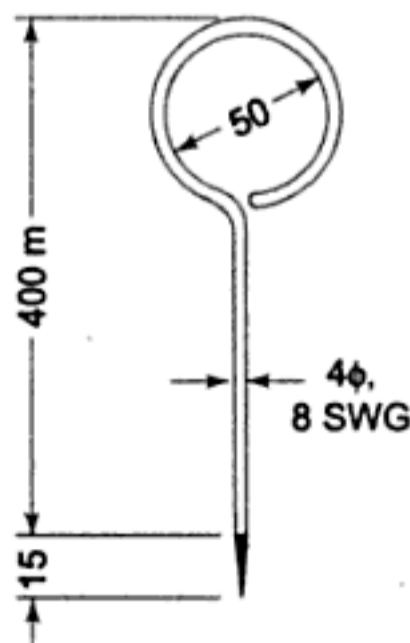

Fig. 2.5 Arrow

indicates the number of chains that have been measured. This provides a check over the length of line as entered in the field notes.

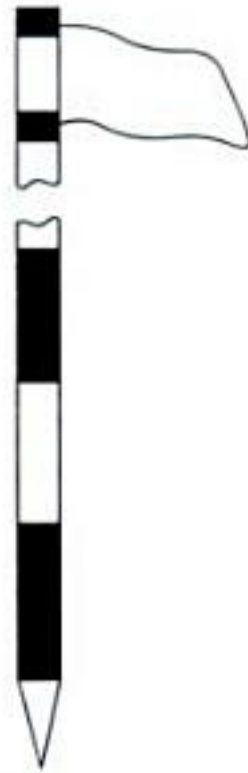

Fig. 2.6 Ranging rod

2.5.3 Ranging Rods

These are also known as *flag poles* or *lining rods*. These are made of well-seasoned straight grain timber of teak, deodar, etc., or steel tubular rods. These are used for marking a point in such a way that the position of the point can be clearly and exactly seen from some distance away. These are 30 mm in diameter and 2 or 3 m long. These are painted with alternate bands of either red and white or black and white of 200 mm length so that on occasions the rod can be used for the rough measurement of short lengths. A cross-shoe of 15 mm length is provided at the lower end. A flag painted red and white is provided at the top, as shown in Fig. 2.6.

These rods are used as signals to indicate the locations of points or the direction of lines. Also, these are used to locate the intermediate points between the two end stations when the length of the line to be measured is more than the chain length. For this purpose line ranger (Sec. 2.6) may also be employed.

2.5.4 Offset Rods

These are similar to ranging rods except at the top where a stout open ring recessed hook is provided, as shown in Fig. 2.7. It is also provided with two short narrow vertical slots at right angles to each other, passing through the centre of the section, at about eye level.

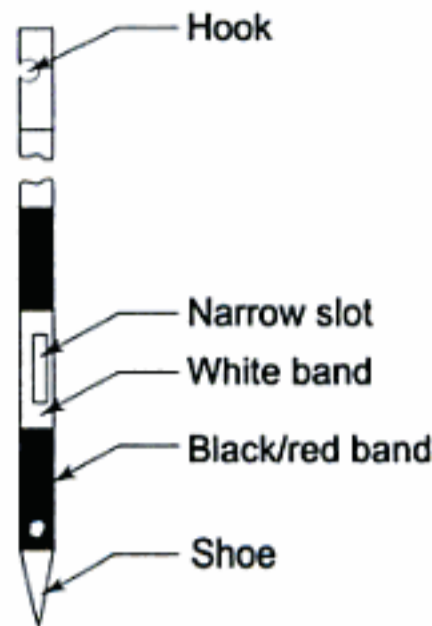

Fig. 2.7 Offset rod

It is mainly used to align the offset line and measuring the short offsets. With the help of hook provided at the top of the rod, the chain can be pulled or pushed through the hedges or other obstructions, if required.

Offsets may also be made in the field with the help of cross-staff (Sec. 2.7) or optical square (Sec. 2.8).

2.5.5 Clinometer

It is an instrument used for measuring the angle of a slope. There is a variety of forms of which the simplest one consists of a graduated semicircle resembling a protector, as shown in Fig. 2.8. A plumb bob is suspended from its centre. Two sight pins A and B are attached along the side of the upper straight diametrical portion.

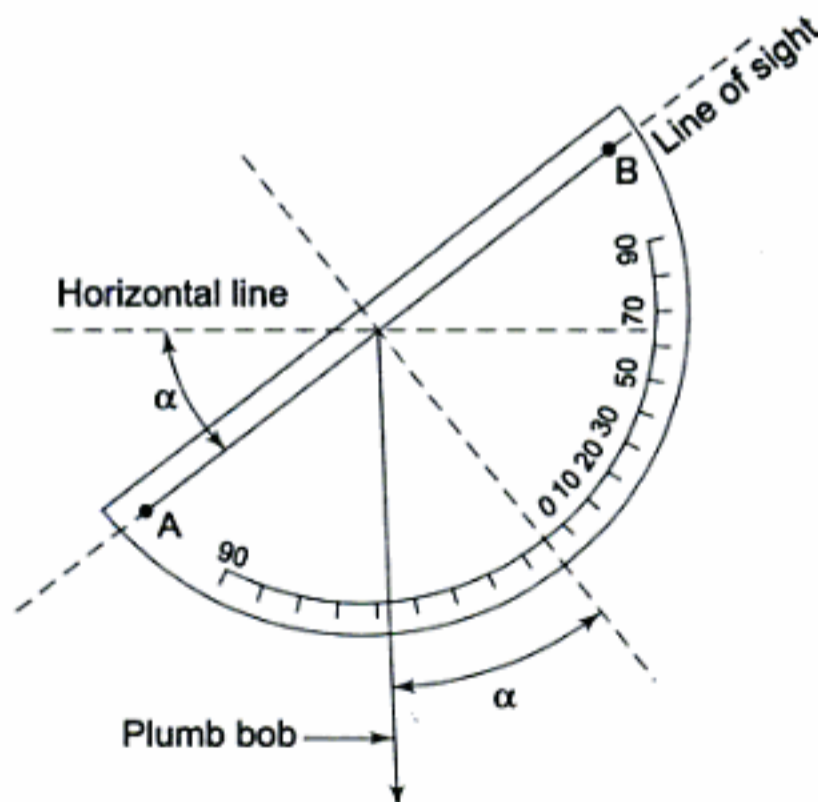

Fig. 2.8 Clinometer

To use the clinometer, a mark is made on the ranging rod at the eye level. The assistant is directed to go up or down the slope along with the ranging rod, as the case may be. The surveyor holds the clinometer at the eye level and sees the mark on the ranging rod through the sight pins. The surveyor then clips the thread of the

plumb bob with the thumb and notes the graduation below the thread. This value is the required angle of slope.

2.5.6 Plumb Bob

It is made of steel in a conical shape, as shown in Fig. 2.9. It is used while measuring distances on slopes and in all the instruments that require centering. Before starting the work, it should be ensured that there are no undesirable knots in the thread of the plumb bob.



Fig. 2.9 Plumb bob

2.6 LINE RANGER

It is a small instrument used to establish intermediate points between two distant points on a chain line without the necessity of sighting from one of them. It consists of two right angled isosceles triangular prisms or two plane mirrors placed one above the other, with their reflecting surfaces normal to each other, as shown in Fig. 2.10(a). One of the prisms is made adjustable to secure the necessary perpendicularity between the two reflecting surfaces.

Let there be two signals A and B on a chain line and C be the intermediate point to be established in line with A and B. The surveyor stands approximately in line with A and B and brings the instrument to his eye level. The instrument is turned so that the surveyor sees the image of one of the signals say A, through the upper prism. The surveyor then moves forward or backward, i.e. at right angles to the chain line AB turning the instrument if necessary so as to keep signal A in view, and until he observes the image of signal at B through the lower prism. Thus the images of the two signals at A and B are seen directly through the upper and lower prisms.

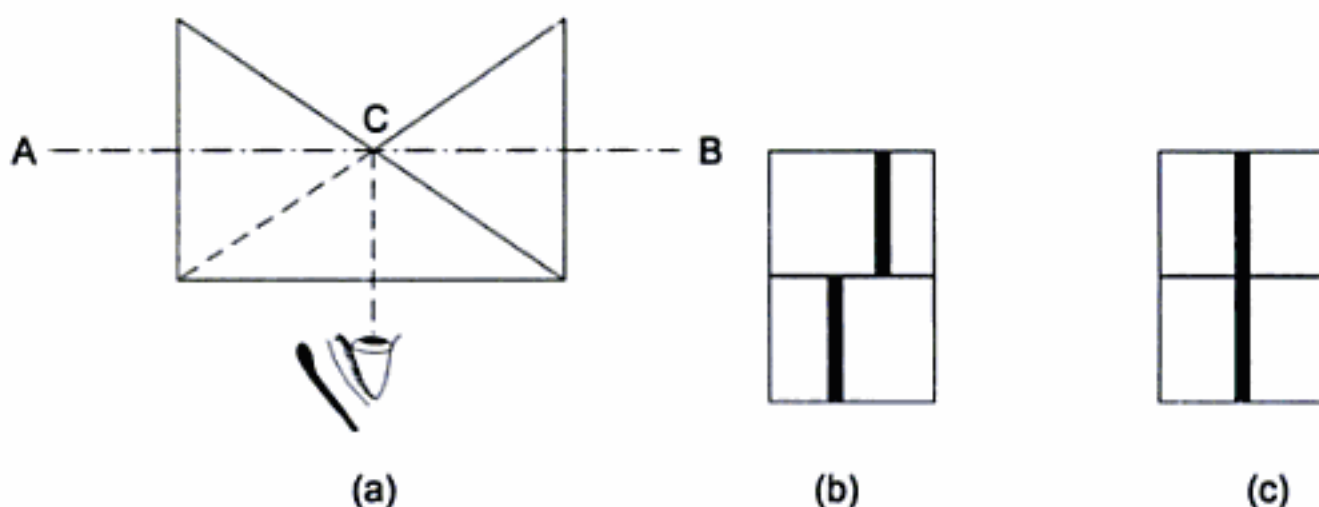

Fig. 2.10 Line ranger

If point C is not in line with A and B, the two images viewed may be separated as shown in Fig. 2.10(b). If so, the surveyor moves backward or forward till the two images coincide as shown in Fig. 2.10(c). The required point C is then vertically below the centre of the instrument.

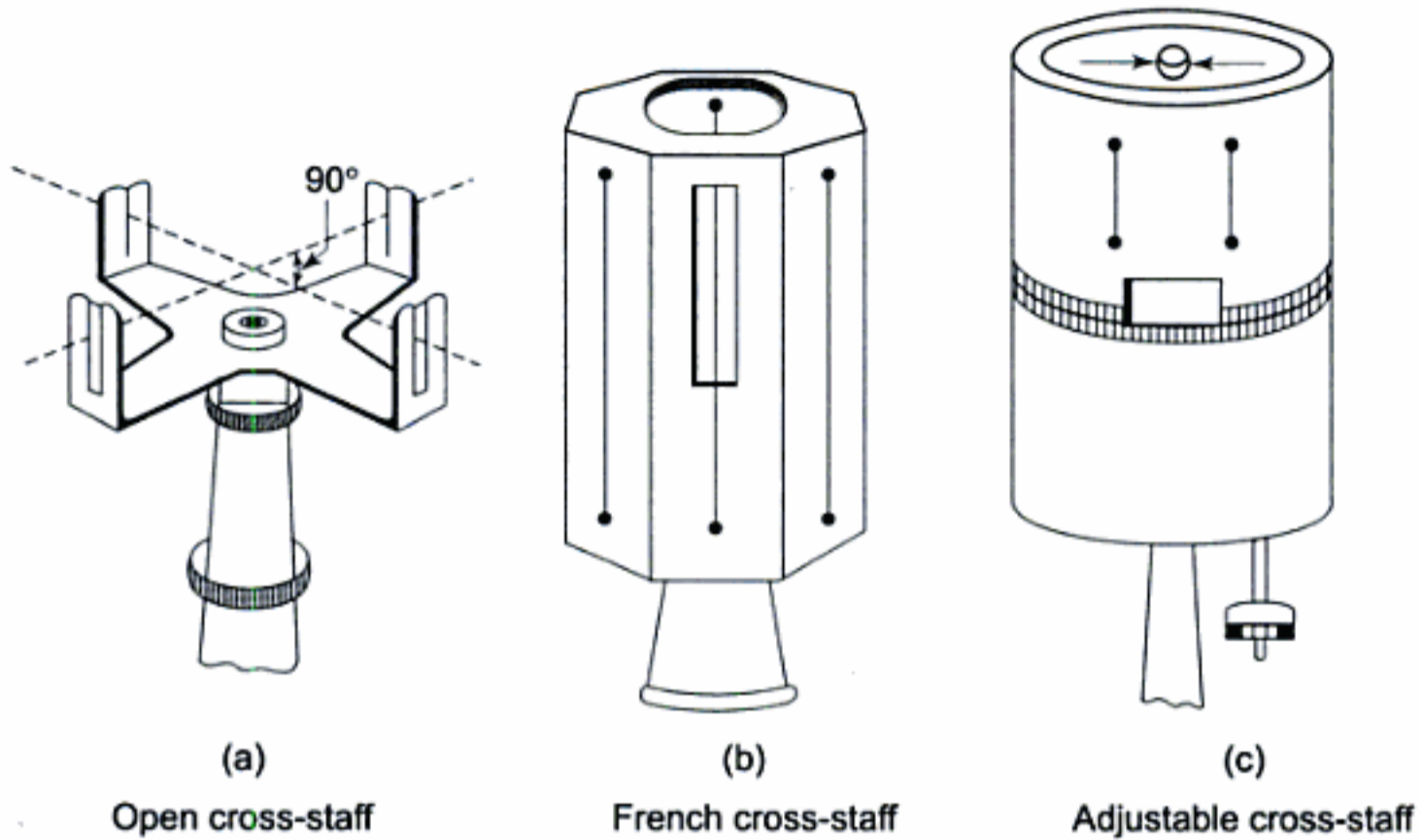

Fig. 2.11 Type of cross-staff

2.7 CROSS-STAFF

It is essentially an instrument used for setting out right angles. In its simplest form it is known as *Open Cross-Staff* (Fig. 2.11(a)). It consists of two pairs of vertical slits providing two lines of sight mutually at right angles. Another modified form of the cross-staff is known as *French Cross-Staff* (Fig. 2.11(b)). This consists of an octagonal brass tube with slits on all eight sides. This has a distinct advantage over the open cross-staff as with it even lines at 45° can be set out from the chain line. The latest modified cross-staff is the *Adjustable Cross-Staff* (Fig. 2.11(c)). It consists of two cylinders of equal diameter placed one above the other. The upper cylinder can be rotated over the lower one graduated in degrees and its subdivisions. The upper cylinder carries the vernier and the slits to provide a line of sight. Thus, it may be used to take offsets and to set out any desired angle from the chain line.

2.7.1 Taking Offsets from a Cross-Staff

To find the foot of a perpendicular from a given point to a chain line, the cross-staff is held vertically on the chain line approximately near the point where the offset is likely to fall. The cross-staff is turned until the signal at one end of the chain line is viewed through one pair of slits. The surveyor then takes a round and views through the other pair of slits. If the point to which the offset is to be taken is seen, the point below the instrument is the required foot of the offset. On the

other hand, if the point is not seen, the surveyor moves along the chain line, without twisting the cross-staff, till the point appears.

2.7.2 Setting out a Right Angle from Chain Line with a Cross-Staff

The surveyor stands at the point from where the right angle is to be set out on the chain line. The surveyor then views through one set of the slits, twists the cross-staff until a signal at one of the end of chain line appears. Then without twisting the cross-staff, he takes a round and views through the other pair of slits. The surveyor then directs the assistant to fix a signal in line with the line of sight provided. The foot of the signal is marked and joined with the point on chain line.

2.8 OPTICAL SQUARE

This is a compact hand instrument to set out right angles and is superior to the cross-staff. It is a cylindrical metal box about 50 mm in diameter and 12.5 mm in depth. Figure 2.12 shows the plan of its essential features. It has two oblong apertures C' and D' on its circumference at right angles to each other. E is a small eye-hole provided diametrically opposite to C' .

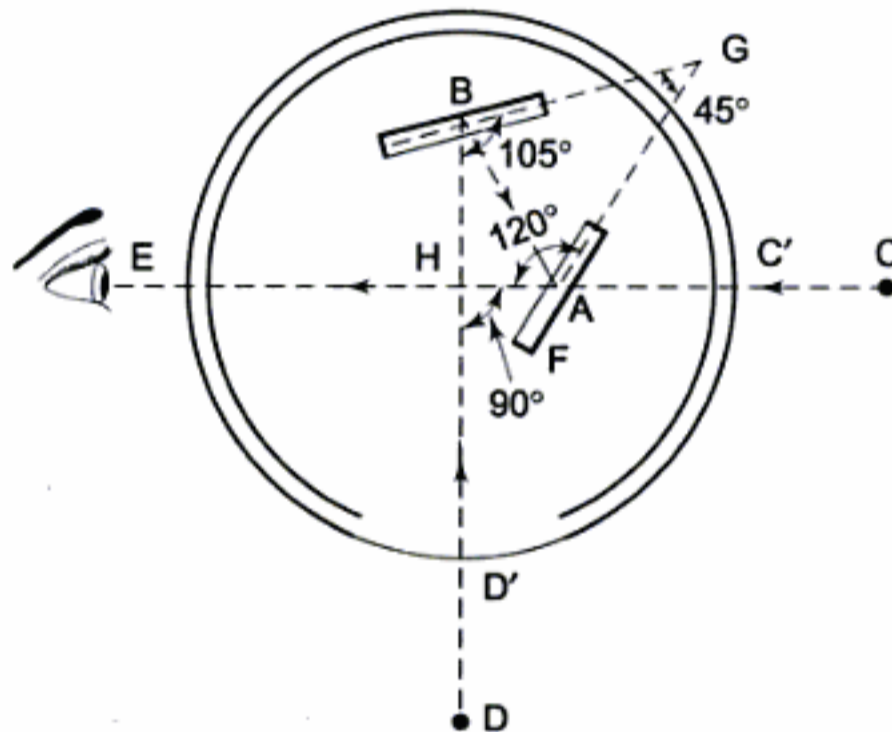

Fig. 2.12 Optical square

The instrument is equipped with two mirrors A and B inclined at an angle of 45° to one another. The mirror A is known as *horizon mirror*, the upper half of which is silvered, whereas the lower half is a plane glass. This is placed opposite to the eye-hole E and is inclined to the axis of the instrument EC at an angle of 120° . The other mirror B is known as *index mirror*. It is completely silvered and is placed diametrically opposite to the aperture D' . It is kept inclined at an angle of 105° to the index sight BD of the instrument. To an eye placed at E , the signal C is visible directly through the transparent half of the horizon mirror. At the same time, the signal D is seen in the silvered portion of the horizon mirror after being reflected through the index mirror B .

2.8.1 Principle

The instrument is based on the principle that a ray of light reflected successively from two surfaces undergoes a deviation of twice the angle between the reflecting surfaces.

2.8.2 Taking Offsets with an Optical Square

Let EC be a survey line which is required to find the foot of the perpendicular to the chain line from a given point D (Fig. 2.13). The surveyor stands on the chain line EC, near the expected point on the chain line, and observes the signal C through the unsilvered portion of the horizon mirror and simultaneously observes the image of the signal D through its silvered portion. He then moves along the chain line until the signal C seen directly and the image of signal D coincide. The point vertically below the instrument is the foot of the required perpendicular.

2.8.3 Setting Out a Right Angle from Chain Line with an Optical Square

Suppose the optical square is required to set out a perpendicular from a point H on a chain line EC, to a curved boundary, as shown in Fig. 2.13. The surveyor stands at H with the optical square at the eye level and turns it until a signal at C is seen directly through the transparent portion of the horizon mirror. The curved boundary will also be visible through the silvered portion of the horizon mirror. The surveyor then directs the assistant at the curved boundary to move left or right until the signal D held by the assistant appears to coincide exactly with the signal C seen directly. The line HD will be the required perpendicular to the chain line EC.

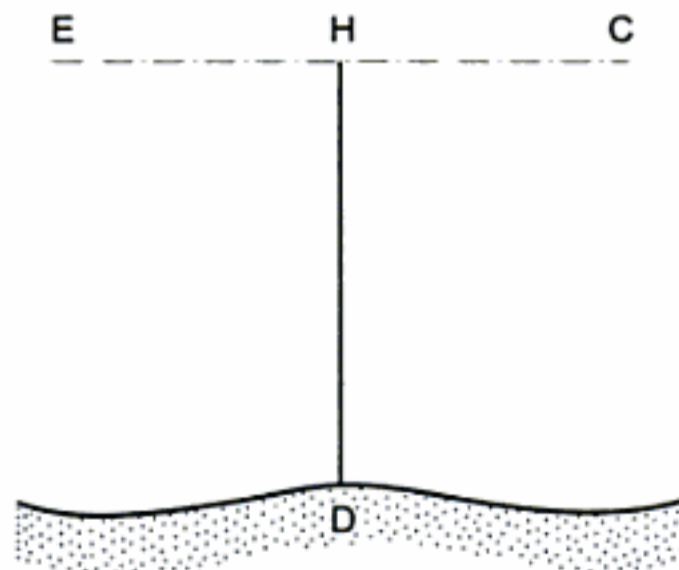

Fig. 2.13 Offset with optical square

Note While using the optical square, it should be ensured that it is held horizontally. Its use is restricted to fairly level ground.

2.8.4 Testing and Adjusting an Optical Square

Object To place the mirrors at 45° to each other so that the angles set out are the right angles.

Test

1. Range out a straight line AC (Fig. 2.14) on a fairly level ground.
2. The surveyor stands at B, sights a signal at C and sets out a right angle, say ABD.

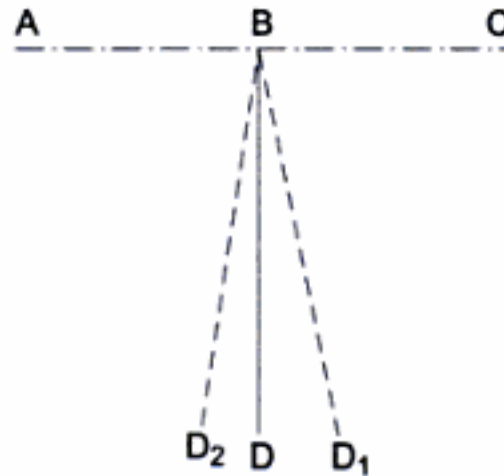

Fig. 2.14 Adjusting optical square

3. The instrument is turned and the surveyor at B sights the signal at A.
4. If the instrument is in adjustment, the image of the signal at D_1 will appear to coincide with the signal at A.

Adjustment

1. If the image of the signal at D_1 does not coincide with the signal at A, mark a point D_2 so that its image coincides with the signal at A.
2. Fix a signal at D exactly midway between D_1 and D_2 .
3. The index mirror which is adjustable is turned until the image of the signal D is made coincident with the signal at A.
4. Signals at C and D are sighted again and now these should appear to coincide.

2.9 PRISM SQUARE

It is based on the same principle as the optical square and is used in the same manner. It has an advantage over the optical square in that no adjustment is required, since the angles between the reflecting surfaces of prisms is kept fixed (45°) as shown in Fig. 2.15.

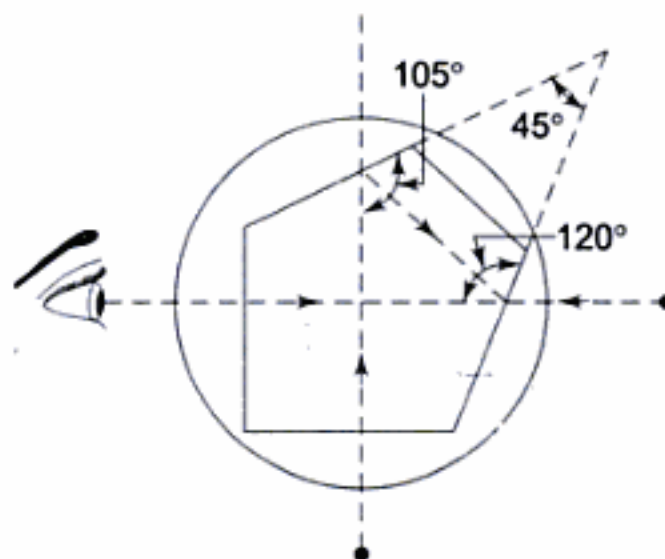

Fig. 2.15 Prism square

2.10 RANGING

It is the process of establishing a number of intermediate points on a survey line joining two stations in the field, so that the length between the stations may be measured accurately.

When the distance to be measured with the chain is less than chain length and the ends are visible, the chain can be laid in true alignment. But when the distance is too long and ends are not intervisible due to intervening ground, obstruction, etc. a number of points with ranging rods are to be marked. Ranging is of two kinds:

- (1) direct ranging, and
- (2) indirect ranging

2.10.1 Direct Ranging

When ranging rods are placed on intermediate points along the chain line by direct observation from either end stations, the process is known as direct ranging (Fig. 2.16).

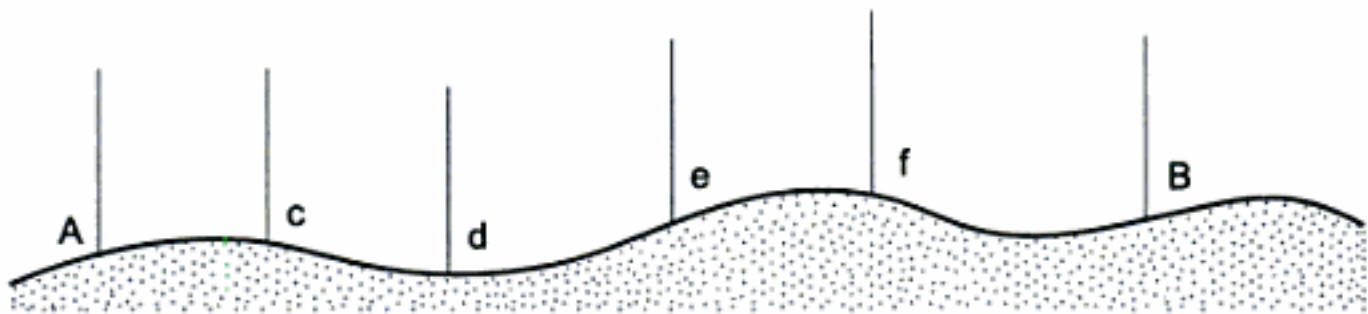

Fig. 2.16 Direct ranging

Let A and B be two end stations and c, d, e, etc. be the intermediate points to be established. The procedure for marking the intermediate points is as follows.

Procedure

1. Ranging rods are erected vertically behind each end of the line.
2. A surveyor stands behind the ranging rods at the end stations A and B of the line.
3. One of the surveyors, say the surveyor at A, directs the assistant to hold a ranging rod vertically at arms length from the point where the intermediate point is to be established.
4. The assistant is directed to move the rod to the right or left until the three ranging rods appear to be exactly in a straight line. The code of signals used is stated in Table 2.1. The signals given by the surveyor are shown in Fig. 2.17.
5. The surveyor at A then sits down and ensures that the bottom of all the three ranging rods are in the same line.
6. The surveyor then signals the assistant to fix the rod.

Table 2.1 Code of signals

<i>S.No. Signal given by the surveyor</i>	<i>Meaning of the signal for the assistant</i>
1. Rapid sweep with right hand (Fig. 2.17 (a)).	Move considerably in that direction (to your left).
2. Slow sweep with right hand.	Move slowly to your left.
3. Right arm extended (Fig. 2.17 (b)).	Continue to move to your left.
4. Right arm up and moved to the right.	Plumb the rod to your left.
5. Rapid sweep with left hand (Fig. 2.17 (c)).	Move considerably in that direction (to your right).
6. Slow sweep with left hand.	Move slowly to your right.
7. Left arm extended (Fig. 2.17 (d)).	Continue to move your right.
8. Left arm up and moved to the left.	Plumb the rod to your right.
Note Signals 5 to 8 are similar to signals 1 to 4.	
9. Both hands above head and then brought down (Fig. 2.17 (e)).	Ranging is correct.
10. Both arms extended forward horizontally and the hands brought down quickly.	Fix the ranging rod.

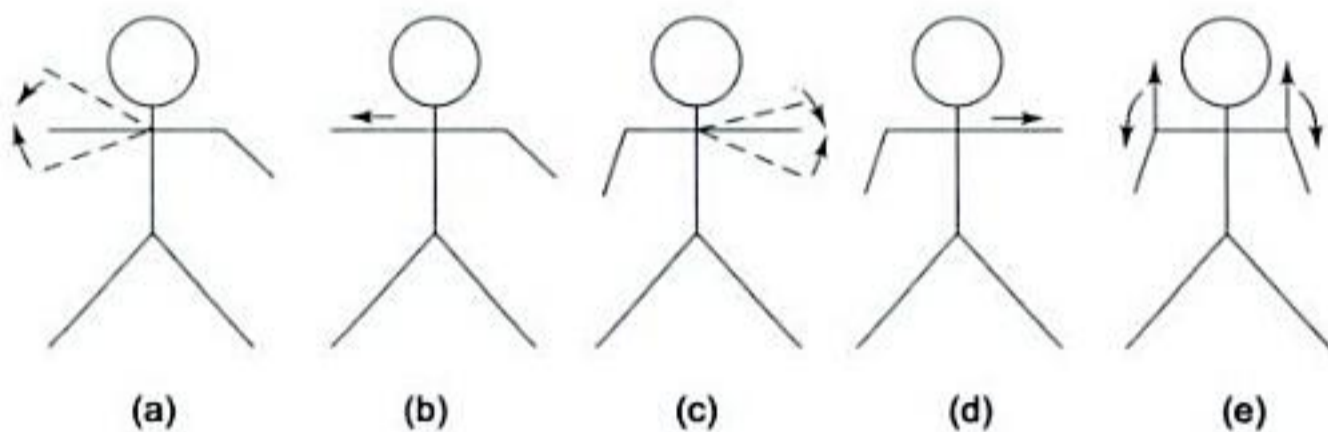

Fig. 2.17 Pictorial representation of signals

Ranging by Line Ranger The instrument and the process have already been described in Sec. 2.6. This method of ranging is very useful and accurate.

2.10.2 Indirect Ranging

When the end stations are not intervisible due to rising ground between them, or due to long distance between the ends, indirect ranging is done. Let A and B be the two end stations of a line with a rising ground between them and C and D the two intermediate points to be established on the chain line (Fig. 2.18).

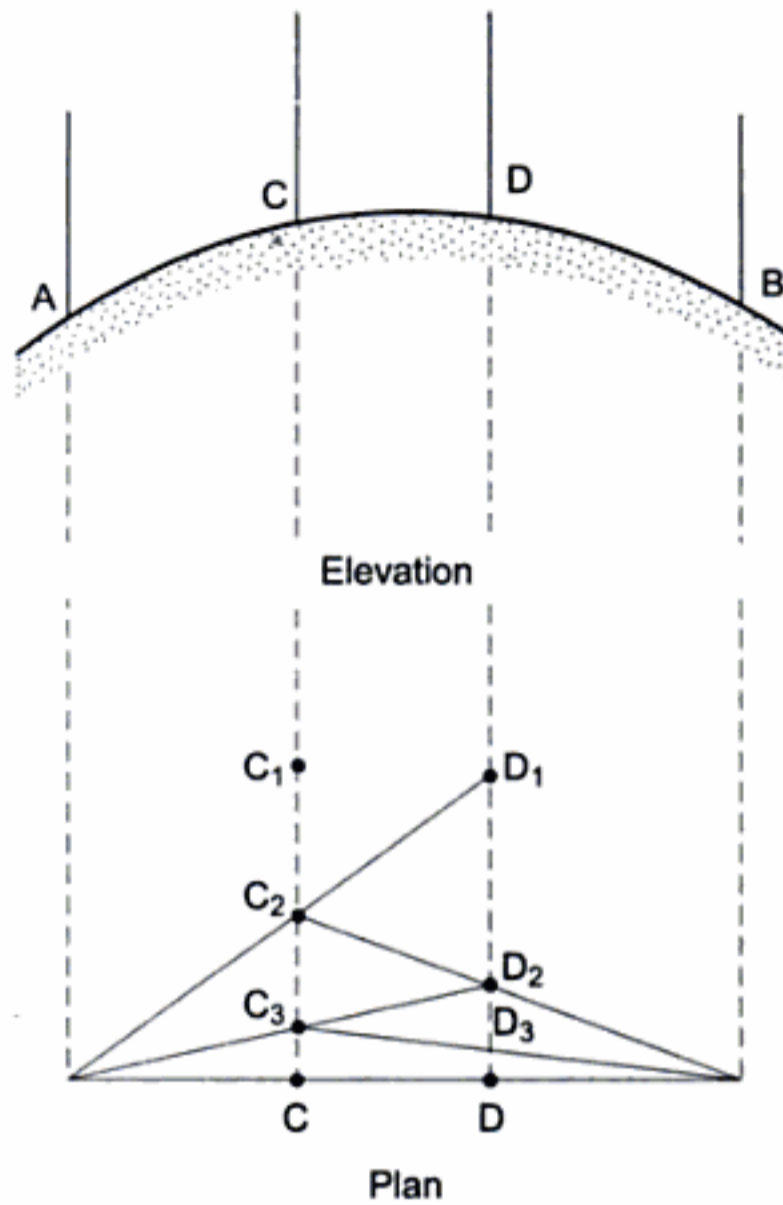

Fig. 2.18 Indirect ranging

Procedure

1. The two chainmen stand at C_1 and D_1 such that the chainman at C_1 can see both the ranging rods at D_1 and B , and the chainman at D_1 can see both the ranging rods at C_1 and A .
2. Now the chainman at D_1 directs the chainman at C_1 to move to C_2 so as to be in line with A .
3. Then the chainman at C_2 directs the chainman at D_1 to move to D_2 so as to be in line with B .
4. By successively directing each other, the two chainmen proceed to the line AB and finally come at C and D exactly in the line AB .
5. C and D are the required intermediate points between A and B .

2.11 CHAINING ON SMOOTH LEVEL GROUND

In measuring a distance that is longer than one chain length, it is necessary to mark chain lengths at intermediate points, and if the total measured distance is to be accurate, it is imperative that these intermediate points be on the line. The procedure for ranging has been discussed in Sec. 2.10. To chain a line on level ground, the following procedure is adopted.

To start with, suppose the distance to be measured is less than one chain length. In the beginning, both the chainmen proceed to one of the points be-

tween which the distance is to be measured. The leader then walks with the zero end of the chain to the other point whereas the follower remains at the initial point. The chain is given a jerk so as to unfold any kinks and to make it straight. It is then stretched straight between the two points in order to count the links to measure the distances.

To chain a line longer than one chain length, the leader and the follower must strictly follow the laid down procedures. The duties of the leader are: to drag the chain forward; to insert arrows at the end of every chain; and to obey the instructions of the follower. On the other hand, the duties of the follower are: to place the leader in line with the ranging rods; to pick up the arrows inserted by the leader; and to carry the rear handle of the chain in his hand. The following steps are followed in chaining a line longer than one chain length:

1. The follower places one of the handles of the chain in contact with the peg.
2. The leader takes the other handle of the chain, ten arrows, ranging rods and moves forward along the line.
3. After the chain is stretched completely along the line, the follower stands on one side of the line with the ranging rod touching the handle.
4. The follower directs the leader to come exactly in line. This can be achieved ensuring that the lower ends of all the three ranging rods are in same line.
5. The leader puts a scratch at the position of rod and inserts an arrow. He then moves forward with the chain handle, the remaining nine arrows, and the ranging rod, till the follower reaches the next peg point.
6. The follower places the handle of the chain in contact with the peg and the entire procedure is repeated till the line is chained.
7. In the end, if some fractional length remains, it is measured by counting the links.
8. During the process, the leader inserts the arrows and the follower picks them up at every chain length. After every tenth chain length the follower erects a ranging rod. He then counts the arrows and transfers them back to the leader.

2.12 CHAINING ON SLOPING GROUND

As stated earlier, in plane surveying, the distances measured should be horizontal. In certain cases, however, the change in elevation from one end of the chain to the other end is so large that the chain cannot be kept horizontal. There are two methods by which the actual horizontal distance can be obtained.

2.12.1 Direct Method

It is also known as *stepping* or *breaking the chain* (using a portion of chain) method. The horizontal distance on the ground is measured directly by the process of stepping which consists of measuring the distance in short horizontal lengths.

Suppose it is required to measure the horizontal distance between P and Q. Evidently, the distance PQ measured will be correct if the chain is held horizontal for each broken chain length and if the position of the broken end of the chain length is projected vertically to the ground by means of a plumb line.

This method is not recommended as mistakes in recording the individual measurements and adding them may be made. However, this method can be used to its advantage when the ground is rough with thick vegetation, weeds, etc., where it may be impractical to hold the chain on the ground. To get the exact measurement, the process of chaining a line on sloping ground is as follows.

1. The follower holds the zero end of the chain at P on the ground while the leader holds its broken end a_1 at a suitable length (say 20 or 30 links) horizontally, as shown in Fig. 2.19.
2. The follower then ranges the leader in line with Q.

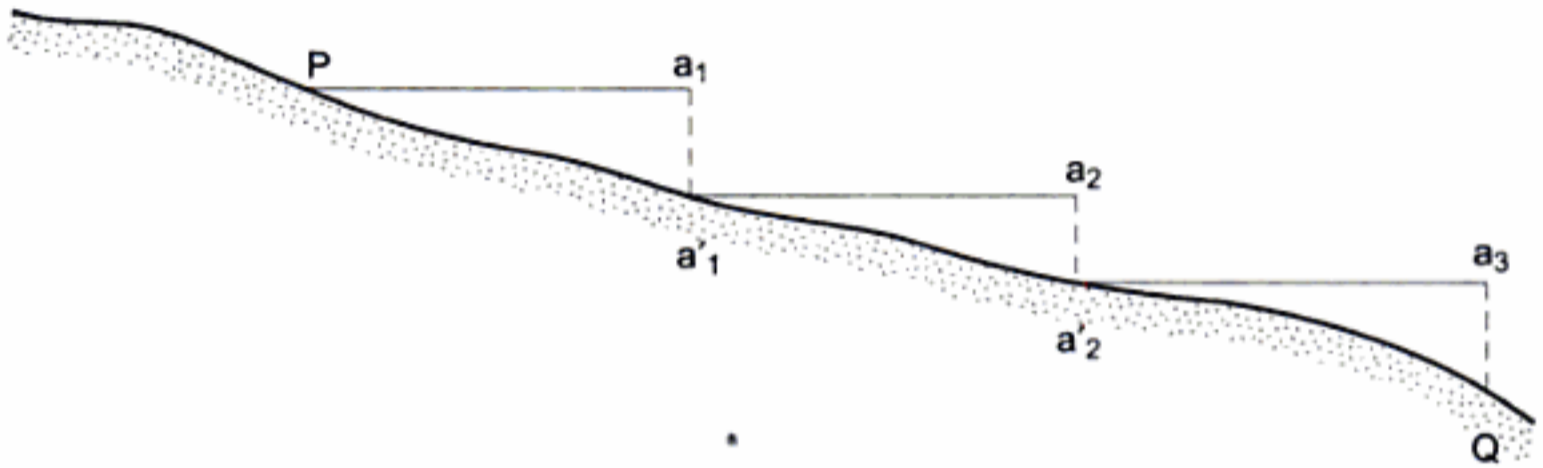

Fig. 2.19

3. The leader transfers the end a_1 to the ground by means of a plumb bob and marks the point a'_1 on the ground with an arrow.
4. The follower moves to a'_1 and holds the zero end of the chain at that point.
5. Steps 1 to 4 are repeated until the end Q is reached.
6. The horizontal distance PQ is the sum of all such measured distance:

$$PQ = Pa_1 + a'_1 a_2 + a'_2 a_3 + \dots$$

Note It is more practicable to chain downhill than to chain uphill. This is so because in the latter case the follower has to hold the chain horizontal with its zero mark exactly above the point on the ground in order to range the leader in line and to resist the pull exerted by the leader on the chain.

2.12.2 Indirect Method

Wherever the chain can be conveniently held on ground, it may be easier to measure a slope distance PQ as shown in Fig. 2.20 and then the corresponding horizontal distance pQ can be computed.

First method The angle PQp (Fig. 2.20) can be measured by a clinometer or on the vertical circle of the transit. Then,

$$pQ = PQ \cos \theta$$



Fig. 2.20

Second method The horizontal distance pQ may be found by applying hypotenusal allowance (Fig. 2.21) as derived below.

Let θ = angle of slope of the ground.

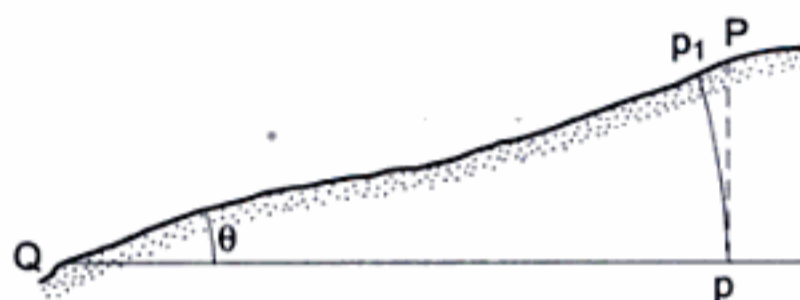

Fig. 2.21

$$pQ = p_1Q = 1 \text{ chain length}$$

$$PQ = \text{chain length} \times \sec \theta$$

Hypotenusal allowance, $Pp_1 = \text{chain length} \times (\sec \theta - 1)$

Therefore, for measuring a distance on slope by this method, the chain is stretched in position p_2Q with the arrow placed in advance by an amount Pp_2 . The next chain length starts from P.

Third method Another method of measuring horizontal distance consists in measuring the slope distance l (PQ) and the difference in elevation h (Fig. 2.22) between the two points by a level. Required horizontal distance is

$$pQ = \sqrt{l^2 - h^2}$$

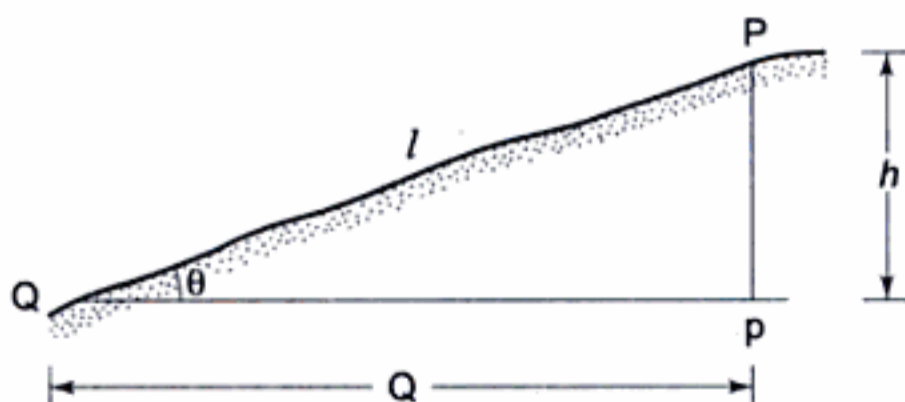

Fig. 2.22

Example 2.1 While measuring the distance on a slope it was found that the ground rises by 3.2 m for each 20 m chain length. Find the angle of slope and the hypotenusal allowance per chain length.

Solution

Let $\theta =$ angle of slope

$$\sin \theta = 3.2/20$$

$$= 0.16$$

or $\theta = 9^\circ 12'$

Hypotenusal allowance $= l (\sec \theta - 1)$

$$= 20 (\sec 9^\circ 12' - 1)$$

$$= 0.261 \text{ m}$$

$$= 26.1 \text{ cm}$$

Hence, the hypotenusal allowance per chain length is 26.1 cm.

Example 2.2 The distance measured between two points on a sloping ground is 450 m. Find the correction to be applied and the horizontal distance if:

- (i) The angle of slope is 10° .
- (ii) The slope is 1 in 5.
- (iii) The difference in elevation between the two points is 45 m.

Solution

- (i) If D is the horizontal distance and l the distance measured along a slope of θ , then

$$\text{Correction to be applied} = l (1 - \cos \theta)$$

$$= 450 (1 - \cos 10^\circ)$$

$$= 6.836 \text{ m}$$

$$\text{Hence, horizontal distance} = 450 - 6.836$$

$$= 443.16 \text{ m.}$$

- (ii) Slope is 1 in 5

$$\therefore \tan \theta = 1/5$$

$$\text{or } \theta = 11^\circ 19'$$

$$\text{Correction to be applied} = l (1 - \cos \theta)$$

$$= 450 (1 - \cos 11^\circ 19')$$

$$= 8.74 \text{ m}$$

$$\text{Hence, horizontal distance} = 450 - 8.74$$

$$= 441.26 \text{ m.}$$

- (iii) Difference in elevation between the points, $h = 45 \text{ m}$

$$\text{Correction to be applied} = h^2/2l$$

$$= (45^2)/(2 \times 450)$$

$$= 2.25 \text{ m}$$

$$\text{Hence, horizontal distance} = 450 - 2.25$$

$$= 447.75 \text{ m.}$$

2.13 ERRORS IN CHAINING

Errors and mistakes in chaining may arise from any one or more of the following sources such as erroneous length of chain, bad ranging, poor straightening, careless holding and marking, variation of temperature, variation of pull, displacement of arrows, miscounting chain lengths, misreading and erroneous booking. It is therefore necessary to know the nature and effects of the various sources of error so as to take care of them during chaining. Errors in chaining are classified as follows: (1) compensating errors and (2) cumulative errors.

2.13.1 Compensating Errors

These are the errors which are liable to occur in both the directions and tend to compensate. Compensating errors are proportional to the square root of the length of the line. They do not affect the results much. The compensating errors are caused by the following:

- (1) Incorrect holding and marking of the arrows.
- (2) Fractional parts of the chain may not be correct, i.e. the chain may not be calibrated uniformly.
- (3) Plumbing may be incorrect while chaining by stepping on slopes.
- (4) In setting chain angles with a chain.

☑ **Note** The compensating errors cannot be corrected as the nature of correction cannot be ascertained.

2.13.2 Cumulative Errors

These are the errors which are liable to occur in the same direction and tend to accumulate. The errors thus considerably increase or decrease the actual measurements. The cumulative errors are proportional to the length of the line and may be positive or negative.

Positive cumulative errors These are the errors which make the measured lengths more than the actual. Therefore, the actual length can be found by subtracting the error from the measured length. These errors may be caused due to the following reasons:

1. The length of chain is shorter than the standard length.
2. Bending of links, knots in links, removal of rings during adjustment of the chain, clogging of rings with mud, etc.
3. Not applying slope correction to the length measured along slopes.
4. Not applying sag correction.
5. Not applying temperature correction when temperature during measurements is less than the standard temperature.
6. Bad ranging, bad straightening, and wrong alignment.

Negative cumulative errors These are the errors which make the measured length less than the actual. Therefore, the actual length can be found by adding

the error to the measured length. These errors may be caused due to the following reasons:

1. Length of the chain is more than its standard length, which may be due to flattening of rings, opening of joints, etc.
2. Not applying the temperature correction when temperature during measurements is more than the standard temperature.

2.14 ERRORS IN MEASUREMENT WITH INCORRECT CHAIN LENGTH

Due to continuous usage of the chain over rough areas, the chain becomes too long or too short over a period of time. If the chain is too long, the measured distance will be less; on the other hand, if too short, the measured distance will be more.

Let l be the true length of the chain and l' be the faulty length of the chain. Then:

True length of the line = $(l'/l) \times$ measured length of the line

True area = $(l'/l)^2 \times$ measured area

True volume = $(l'/l)^3 \times$ measured volume

Example 2.3 The length of a line measured with a chain was found to be 250 m. Calculate the true length of the line if

- (i) the length was measured with a 30 m chain and the chain was 10 cm too long, and
- (ii) the length of chain was 30 m in the beginning and 30.10 m at the end of work.

Solution

Measured length, $L = 250$ m

True length of chain, $l = 30$ m

- (i) Incorrect or actual length of the chain used, $l' = 30.10$ m

$$\begin{aligned} \text{True length of line, } L_1 &= (l'/l)L \\ &= (30.10/30) \times 250 = 250.83 \text{ m} \end{aligned}$$

- (ii) $l =$ average length of the chain during measurement

$$= (30 + 30.10)/2 = 30.05 \text{ m}$$

$$\therefore L_1 = (30.05/30) \times 250 = 250.416 \text{ m}$$

Example 2.4 The area of the plan of an old survey plotted to a scale of 10 m to 1 cm now measures as 90.5 cm^2 as found by a planimeter. The plan is found to have shrunk so that a line originally 10 cm long now measure 9.5 cm only. A note on the plan also states that the 20 m chain used was 9 cm too short. Find the true area of the survey.

Solution

$$\begin{aligned} \text{Original area on plan, } A &= (10/9.5)^2 \times 90.5 \\ &= 100.2770 \text{ cm}^2 \end{aligned}$$

The scale of the plan is: 10 m = 1 cm

$$\begin{aligned}\text{Hence, area on ground} &= 100.277 \times (10)^2 \\ &= 10027.70 \text{ m}^2\end{aligned}$$

Since, the chain was 0.9 cm too short, and $l = 20$ m

$$l' = 20 - 0.09 = 19.91 \text{ m}$$

$$\begin{aligned}\text{True area of the field} &= (19.91/20)^2 \times 10027.70 \\ &= 9937.6538 \text{ m}^2.\end{aligned}$$

Example 2.5 A distance of 2000 m was measured by a 30 m chain. Later, it was detected that the chain was 0.1 m too long. Another 500 m was measured and it was detected that the chain was 0.15 m too long. If the chain was correct initially, determine the exact length that was measured.

Solution

The chain was correct in the beginning, but after measuring 2000 m it was found to be 0.1 m too long.

Hence, the mean elongation of chain for this distance

$$= (0.00 + 0.10)/2 = 0.05 \text{ m}$$

The mean length of the chain while measuring first 2000 m, $l' = 30.05$ m

$$\begin{aligned}\text{True distance, } L_1 &= (l'/l) \times \text{measured distance} \\ &= (30.05/30) \times 2000 = 2003.334 \text{ m}\end{aligned}$$

For the next 500 m measurement, it was found to be 0.15 m too long at the end.

The mean elongation for the next 500 m distance

$$\begin{aligned}&= (0.10 + 0.15)/2 \\ &= 0.125 \text{ m}\end{aligned}$$

$$\text{Now, } l' = 30 + 0.125 = 30.125 \text{ m}$$

$$\begin{aligned}\text{Hence, true distance, } L_2 &= (30.125/30) \times 500 \\ &= 502.083 \text{ m}\end{aligned}$$

$$\begin{aligned}\text{Total measured length} &= L_1 + L_2 \\ &= 2003.334 + 502.083 \\ &= 2505.417 \text{ m}\end{aligned}$$

2.15 TAPE CORRECTIONS

Depending upon the accuracy required in taping, certain corrections are made to the original measured distance. It is a standard practice not to correct each tape length as it is measured, but to record the measurements as made with the tape used and then to apply corrections to the total distance. The major sources of error in taping can be identified in terms of the following corrections.

2.15.1 Correction for Standard Length

Before using a tape, the actual length is ascertained by comparing it with a standard tape of known length. If the actual tape length is not equal to the standard value, a correction will have to be applied to the measured length of the line:

$$C_a = \frac{LC}{l}$$

where

C_a = correction for absolute length

C = correction to be applied to the tape

L = measured length of the line (in m)

l = nominal length of the tape (in m)

The sign of the correction C_a will be same as that of C .

2.15.2 Correction for Slope

The distance measured along the slope is always greater than the horizontal distance between the points. Therefore, if the distance is measured on the slope, it must be immediately reduced to its corresponding horizontal distance (Fig. 2.23).

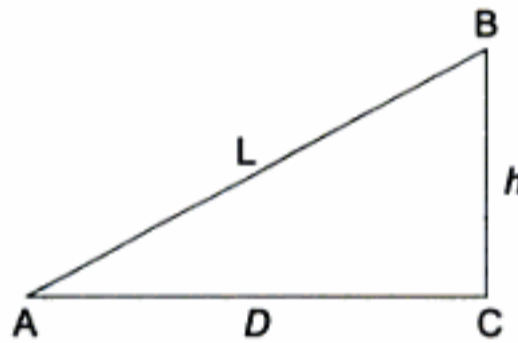

Fig. 2.23

$$D = \sqrt{L^2 - h^2}$$

$$C_{sl} = L - D$$

The slope correction, $C_l = L - (L^2 - h^2)^{1/2}$

$$= L - L(1 - h^2/L^2)^{1/2}$$

$$= L - L[1 - h^2/(2L)^2 - h^4/(8L)^4 - \dots]$$

$$= L - L + h^2/2L + h^4/8L^3 + \dots$$

$$= h^2/2L \text{ (neglecting the higher order terms)}$$

$$C_{sl} = h^2/2L$$

where h = difference in elevations of A and B

L = measured length of the line (in m)

The slope correction is C_{sl} always subtractive.

2.15.3 Correction for Tension (Pull)

If the pull applied to the tape during measurement is more than the standard pull at which the tape was standardised, its length increases. Hence the distance

measured becomes less than the actual. The pull correction C_p is given by the formula:

$$C_p = \frac{P - P_0}{AE} L$$

where P_0 = standard pull

P = pull applied during measurement

A = area of cross-section of the tape (in cm^2)

E = modulus of elasticity of tape

= 2.1×10^5 N/ mm^2 for steel

= 1.54×10^5 N/ mm^2 for invar

L = measured length (in m)

Tension correction is positive, if the applied pull is more than the standard pull, and negative, if the applied pull is less than the standard pull.

2.15.4 Correction for Temperature

The tape length changes due to changes in the temperature while taking the measurements. The temperature correction C_t which, therefore, needs to be made is given by:

$$C_t = \alpha (T_m - T_0)L$$

where T_m = mean temperature during measurement

T_0 = temperature of standardisation

α = coefficient of thermal expansion of material

= $0.0000035/^\circ\text{C}$ for steel

= $0.000000122/^\circ\text{C}$ for invar

L = measured length (in m)

The correction is positive, if the temperature during measurement is more than the standard temperature, and negative, if the temperature during measurement is less than the temperature at which the tape was standardized.

2.15.5 Sag Correction

When the tape is stretched between two points, it takes the form of catenary (assumed to be a parabola). Consequently, the measured length is more and the correction is applied. The sag correction C_{sa} is given by the formula:

$$C_{sa} = \frac{(wl_1)^2 l_1}{24P^2} = \frac{W^2 l_1}{24P^2}$$

If there are n equal spans per tape length, the correction per tape length is given by

$$C_{sa} = n \frac{(wl_1)^2 l_1}{24P^2} = \frac{(wl/n)^2 nl_1}{24P^2}$$

$$= \frac{(wl)^2 l}{24n^2 P^2} = \frac{W^2 l}{24n^2 P^2}$$

where w = weight of the tape per metre length

W = total weight of the tape

P = pull applied (in N)

l_1 = the length of tape suspended between two supports

l = length of the tape = nl_1 (in m)

Sag correction is always negative.

2.15.6 Reduction to Mean Sea Level

The length of a line measured at an altitude of h metres above mean sea level (Fig. 2.24) is always more as compared to the length measured on the mean sea level (m.s.l.) surface. The necessity of reducing distances to a common datum arises when the surveys are to be connected to the national grid. The correction denoted by C_R is given by the formula:

$$C_R = \frac{h}{R} L$$

where R is the radius of the earth.

The correction is always subtractive.

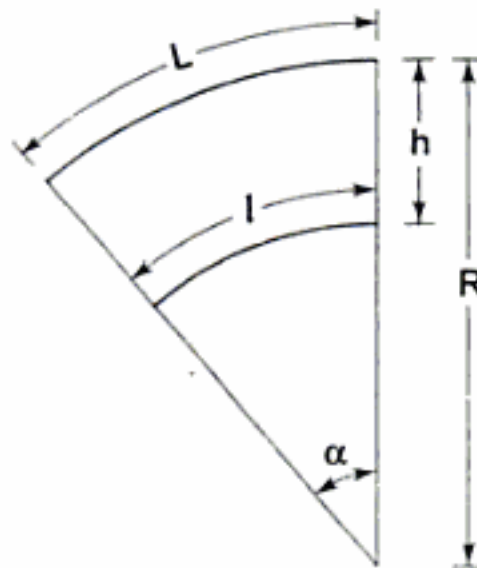

Fig. 2.24

2.15.7 Combining Corrections

In actual practice, each of the above correction, based on the length recorded, are combined by addition. But strictly speaking, correction should be combined by successive multiplication. Let us assume that for a given length, the following unit corrections have been computed and are to be applied.

Unit sag correction = a

Unit slope correction = b

Unit temperature correction = c

True length = L

Recorded length = L'

Then

$$L = L' (1 + a) (1 + b) (1 + c)$$

$$= L' (1 + a + b + c + ab + bc + ca + abc)$$

The values of a , b , and c are very small and hence their products can be neglected. Eliminating such products.

$$L = L' (1 + a + b + c)$$

$$= L' + L'a + L'b + L'c$$

Thus, each of the correction can be based on the length recorded and combined by addition.

2.15.8 Normal Tension

The pull or tension which, when applied to a tape suspended in the air, equalises the correction due to pull and sag is known as normal tension.

For one tape length,

$$C_p = \frac{(P - P_0) l}{AE}$$

and

$$C_{sa} = \frac{W^2 l}{24P^2}$$

Since,

$$C_p = C_{sa}$$

$$\frac{(P - P_0) l}{AE} = \frac{W^2 l}{24P^2}$$

$$P = \frac{0.204W \sqrt{AE}}{\sqrt{P - P_0}}$$

The value of P may be calculated by trial and error.

Example 2.6 A line was measured with a steel tape which was exactly 30 m at a temperature of 20°C and a pull of 10 kg. The measured length was 1650 m. The temperature during measurement was 30°C and the pull applied was 15 kg. Find the true length of the line, if the cross-sectional area of the tape was 0.025 cm². The coefficient of expansion of the material of the tape per °C is 3.5×10^{-6} and modulus of elasticity of the material of tape is 2.1×10^6 kg/cm².

Solution

Correction to be applied are: (1) correction for temperature and (2) correction for pull.

(1) Correction for temperature:

$$C_t = \alpha (T_m - T_0)L$$

$$= 3.5 \times 10^{-6} (30 - 20) 1650$$

$$= 0.05775 \text{ m (+ve)}$$

(2) Correction for pull:

$$C_p = \frac{(P - P_0) L}{AE}$$

$$= \frac{(15 - 10)}{0.025 \times 2.1 \times 10^6} 1650$$

$$= 0.157101 \text{ m (+ve)}$$

$$\begin{aligned} \text{True length of the line} &= 1650 + 0.05775 + 0.157101 \\ &= 1650.214831 \text{ m.} \end{aligned}$$

Example 2.7 The downhill end of a 30 m tape is held 90 cm too low. What is the horizontal distance measured?

Solution

$$\begin{aligned} \text{Correction for slope} &= h^2/2L \\ &= (0.9)^2/(2 \times 30) \\ &= 0.0135 \text{ m} \end{aligned}$$

$$\begin{aligned} \text{Hence, the horizontal distance} &= 30 - 0.0135 \\ &= 29.9865 \text{ m} \end{aligned}$$

Example 2.8 A 100 m tape is suspended between the ends under a pull of 200 N. The weight of the tape is 30 N. Find the correct distance between the tape ends.

Solution

$$\begin{aligned} \text{Correction for sag} &= \frac{W^2 l_1}{24P^2} \\ &= ((30)^2 \times 100)/(24 \times (200)^2) \\ &= 0.09375 \text{ m} \end{aligned}$$

$$\begin{aligned} \text{Horizontal distance} &= 100 - 0.09375 \\ &= 99.90625 \text{ m.} \end{aligned}$$

2.16 OFFSETS

The distance measured right or left of the chain line to locate the details like boundaries, culverts, etc., as shown in Fig. 2.25 are called offsets. There are two types of offsets: (1) Perpendicular offsets and (2) Oblique offsets.

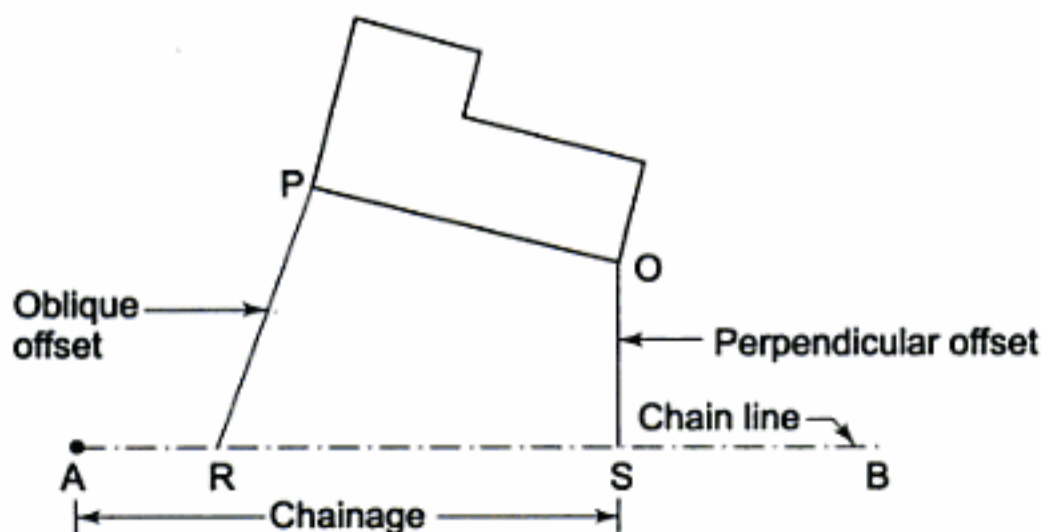

Fig. 2.25 Offsets

2.16.1 Perpendicular Offsets

When the lateral measurements for locating details are at right angles to the chain line, the offsets are called *perpendicular offsets*.

2.16.2 Oblique Offsets

When the lateral measurements for fixing details are not at right angles to the chain line, the offsets are called *oblique offsets*. These are used to check the accuracy of perpendicular offsets and to locate the corners of buildings more accurately.

2.16.3 Limiting Length of Offset

The offset should not be too long. Otherwise, the error produced by long offsets will be appreciable on paper. The limiting length depends on many factors, such as: accuracy desired, scale of plotting, maximum error in laying off the direction of offset, and nature of the ground.

Effect of error due to direction Let P be a point from where an offset PC has been laid instead of PD on a chain line AB. The length of the offset PC is l and α is the error made in laying the offset on ground. This, when plotted on paper will be CP_1 instead of CP (Fig. 2.26). Thus, the point P is displaced by PP_2 along the chain line and by P_2P_1 perpendicular to the chain line. If the scale of plotting is $1 \text{ cm} = S \text{ m}$

$$PP_2 = \frac{l \sin \alpha}{S}$$

If limit of accuracy in plotting = 0.025 cm

$$\frac{l \sin \alpha}{S} = 0.025$$

or $l = 0.025 S \operatorname{cosec} \alpha$

Therefore, the limiting length of offset is $0.025 S \operatorname{cosec} \alpha$ for an error of α in laying the offset and the displacement of point perpendicular to chain line P_1P_2 on paper will be

$$P_1P_2 = CP_1 - CP_2 = \frac{l - l \cos \alpha}{S}$$

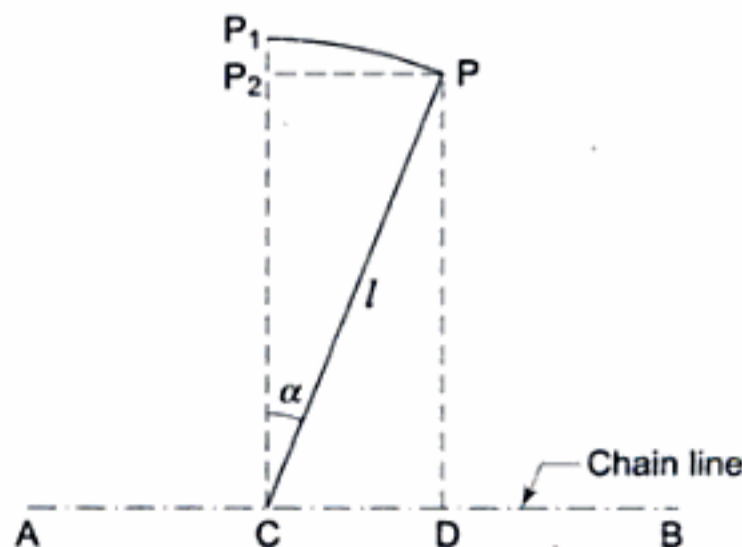

Fig. 2.26 Error in direction of offset

Combined effect of error in direction and length Let P be a point from where an offset PC is laid on a chain line AB. The measured length of the offset CP_1 is l and the error in direction is α (Fig. 2.27). Let 1 in r be the accuracy in measurement of the offset and scale of plotting be 1 cm = S m. Then the total error is PP_2 .

Assuming angle $PP_1P_2 = 90^\circ$

The displacement due to angular error, $P_1P_2 = l \sin \alpha$ and it should be equal to displacement due to the linear error, $P_1P = l/r$

$$\begin{aligned} PP_2 &= \sqrt{2} \quad PP_1 = \sqrt{2} \quad P_1P_2 \\ &= \sqrt{2} (l/r) \end{aligned}$$

also $= \sqrt{2} l \sin \alpha$

Corresponding displacement on paper

$$= \sqrt{2} (l/r) (1/S)$$

also $= \sqrt{2} l \sin \alpha / S$

If limit of accuracy in plotting is 0.025 cm, then

$$(\sqrt{2} l/r) (1/S) = 0.025$$

or $l = (0.025/\sqrt{2}) r S$

also $\sqrt{2} l \sin \alpha / S = 0.025$

or $l = (0.025/\sqrt{2}) S \operatorname{cosec} \alpha$

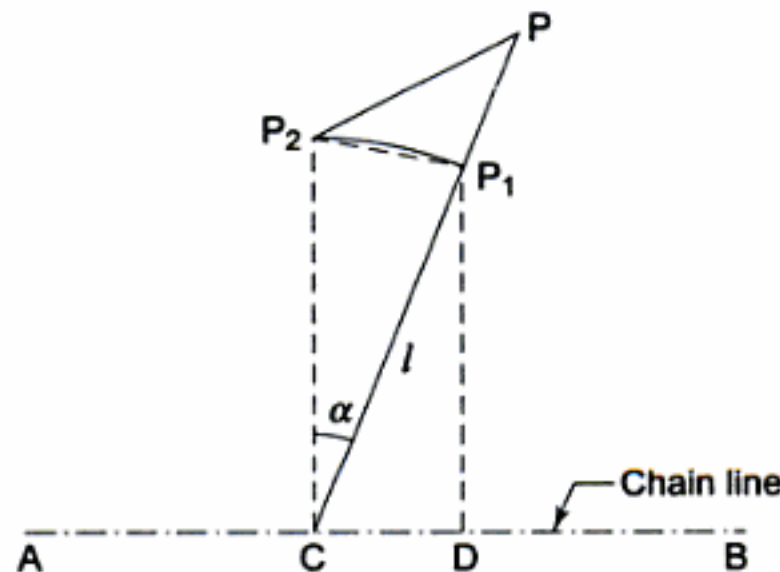

Fig. 2.27 Error in direction and length of offset

2.16.4 Taking Offsets

Let P be a point where the offset is to be taken (Fig. 2.28). The leader holds the zero end of the tape at the point P and the follower swings off the tape in an arc with P as the centre, as shown in Fig. 2.28. The minimum reading of tape on the chain line gives the position of the foot of the perpendicular from P. An offset taken in such a way is also called *swing offset*.

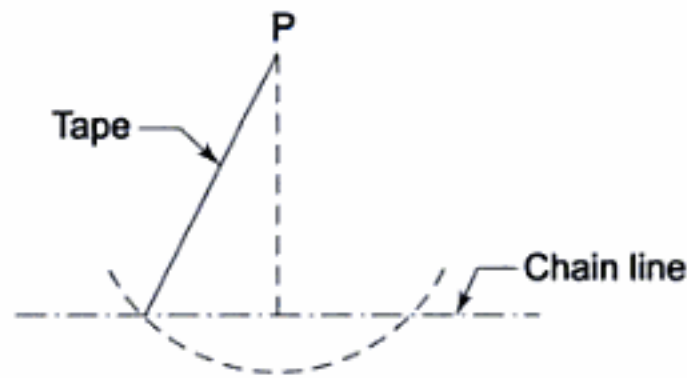

Fig. 2.28 Taking offsets

2.16.5 Establishing Perpendicular to a Chain Line

The most common method of erecting a perpendicular to a chain line is the 3-4-5 method. In Fig. 2.29, AB is a chain line and C is the point from which a perpendicular is to be erected. Establish a point E on the chain AB at 3 links from C. Count 5 chain links from E and with E as the centre, mark an arc in the field. Similarly, with 4 chain links from C and with C as the centre mark, another arc intersecting the previous one in P is constructed. CP is the desired perpendicular at C.

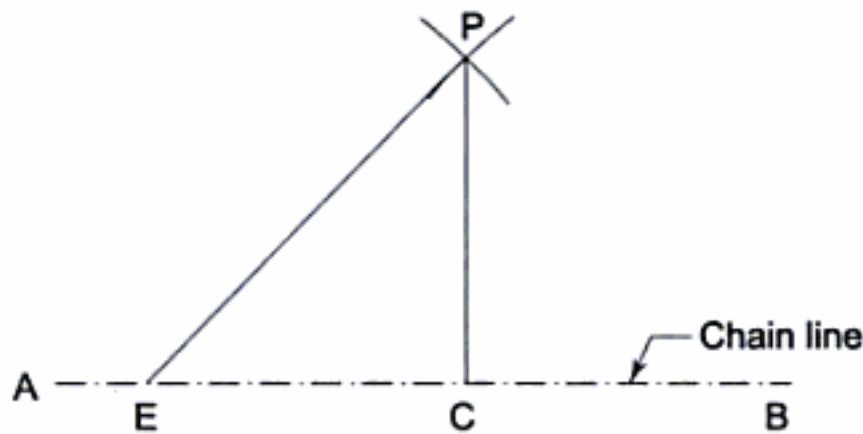

Fig. 2.29 Establishing perpendicular to a chain line

Example 2.9 An offset is laid 4° out from its true direction in the field. Find the resulting displacement of the plotted point on the plan for the following cases, if the offset measured was 8.0 m and the scale of plotting was 6 m to 1 cm:

- In the direction parallel to the chain line.
- In the direction perpendicular to the chain line.

Solution

- Displacement of the point on ground parallel to chain line

$$= l \sin \alpha$$

$$= 8 \sin 4^\circ$$

$$= 0.558 \text{ cm}$$

The scale of plan is 6 m to 1 cm

$$\text{Displacement of the point on plan} = \frac{l \sin \alpha}{S}$$

$$\begin{aligned}
 &= \frac{0.558}{6} \\
 &= 0.093 \text{ cm}
 \end{aligned}$$

(ii) Displacement of the point on ground perpendicular to the chain line

$$\begin{aligned}
 &= l(1 - \cos \alpha) \\
 &= 8(1 - \cos 4^\circ) \\
 &= 0.01948 \text{ cm}
 \end{aligned}$$

$$\begin{aligned}
 \text{Displacement of the point on plan} &= \frac{l(1 - \cos \alpha)}{S} \\
 &= \frac{0.01948}{6} \\
 &= 0.003 \text{ cm}
 \end{aligned}$$

Example 2.10 Find the limiting length of an offset so that the displacement of a point on the paper may not exceed 0.025 cm. The offset was laid 3° out from its true direction and the scale was 10 m to 1 cm.

Solution

$$l \sin \alpha / S = 0.025$$

$$\begin{aligned}
 \text{or} \quad l &= 0.025 S \operatorname{cosec} 3^\circ \\
 &= 0.025 \times 10 \times \operatorname{cosec} 3^\circ \\
 &= 4.78 \text{ m}
 \end{aligned}$$

Example 2.11 Find the maximum length of an offset so that the displacement of the plotted position of the point on the paper from both sources of error does not exceed 0.025 cm. The offset is measured with an accuracy of 1 in 30 and the scale used is 1 cm = 25 m.

Solution

The displacement of point on the ground from both sources of error

$$\begin{aligned}
 &= \frac{\sqrt{2}l}{r} \\
 &= \frac{\sqrt{2}l}{30} \text{ cm}
 \end{aligned}$$

The scale of plotting is 25 m = 1 cm

$$\text{The displacement of point on paper} = \frac{\sqrt{2}l}{30 \times 25} \text{ cm}$$

$$\text{Then} \quad \frac{\sqrt{2}l}{30 \times 25} = 0.025$$

or $l = 13.258 \text{ m.}$

Hence, the maximum length of offset should be 13.258 m.

Example 2.12 The angular error in laying off the perpendicular direction of an offset was found to be 5° . What should be the accuracy with which the offset should be measured so that the maximum displacement of point on paper from both the sources of error be the same.

Solution

$$l \sin \alpha = \frac{l}{r}$$

or $l \sin 5^\circ = l/r$

or $r = \operatorname{cosec} 5^\circ$
 $= 11.47$

Hence, the offset must be measured with an accuracy of about 1 in 11.47 m.

2.17 FIELD BOOK

The chain survey work is recorded in a book known as field book. It is of $200 \text{ mm} \times 120 \text{ mm}$ size. The pages of the field book can have either a red line or two blue lines $12.5 - 15 \text{ mm}$ apart ruled down the middle of each page. The field work is commenced at the bottom of the page and worked upwards as shown in Fig. 2.30. Following details are recorded in the field book on the commencement of a chain line.

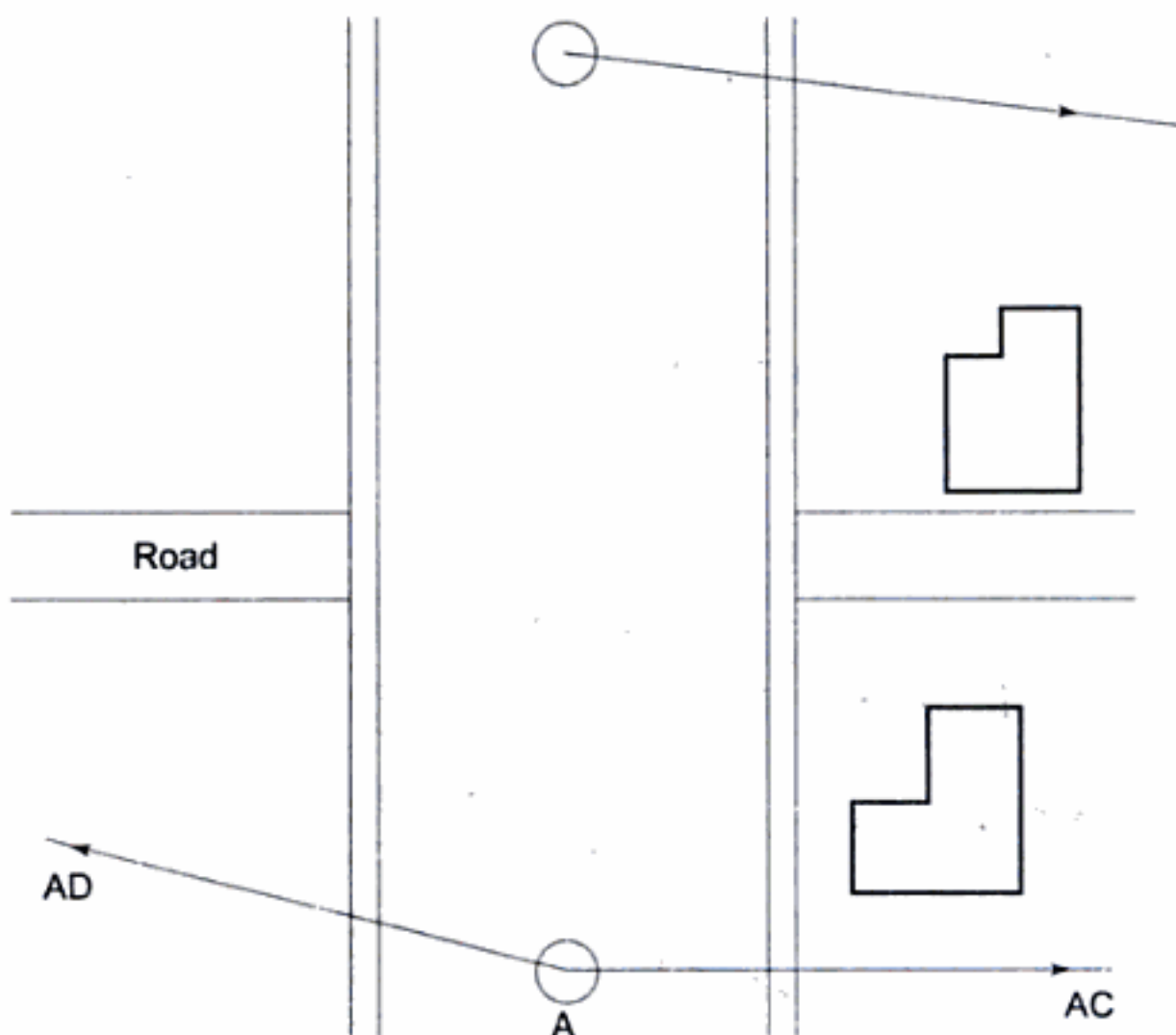

Fig. 2.30

1. Name or number of the chain line.
2. Name or number of the station.
3. The symbol denoting the station mark.
4. The direction of other survey lines at the stations.
5. The initial chainage (generally zero) enclosed in the symbol.

☑ **Note** To facilitate reference, no line is commenced on the same page that contains a finish of another line.

Booking the Data

In recording measurements as they are being taken in the field, the notekeeper should ensure that every measurement that should be recorded is taken and that every measurement taken is recorded. Every linear measurement should be recorded in such a way that the last digit will indicate the degree of precision with which the measurement was made. The following points should be observed while booking the data.

1. Chainage is written in the central column.
2. Chainage of the stations may be enclosed in a circle or ellipse.
3. Objects are sketched along the sides of the chain line.
4. Offsets are written close to the object.
5. Chainage of corners of the object are also entered.
6. When features like road, fence, lake, etc. cross the chain line, the chainage of intersection is entered and the direction of the feature is sketched.
7. Oblique offsets are written along with dimension line in the direction of the offset.

2.18 OBSTACLES TO CHAINING

The measurement of distances consists of chaining and making offsets. During measurements, it is practically impossible to set out all the chain lines in a straightforward method because of a variety of obstructions to chaining and ranging in the field. The difficulties can be overcome by running perpendicular and parallel lines or by running a few additional lines and measuring angles by some instrument. The scope of the chapter limits the solution of the problems involving only the essential equipments used in chain surveying. To find the best and rapid solution, the surveyor should have a good knowledge of geometric and trigonometric principles.

The obstacles may be divided into two classes. Those which do not obstruct the ranging (view) like ponds, rivers and fall in the category of *obstacles to measurement*. The others are those which we cannot see across, i.e. both the chaining and ranging are obstructed, e.g. houses, stacks, etc., and are known as *obstacles to alignment*. Only a few solutions have been discussed here and many more can be developed by the surveyor himself, depending upon the field conditions and method resorted to.

2.18.1 Obstacles to Measurement

First method (Fig. 2.31) Let ABCD be a chain line obstructed by a pond. The problem consists in finding out the distance BC. Two offsets BE and CF of equal length are made at B and C and chaining is done along EF. The work is then continued from point C.

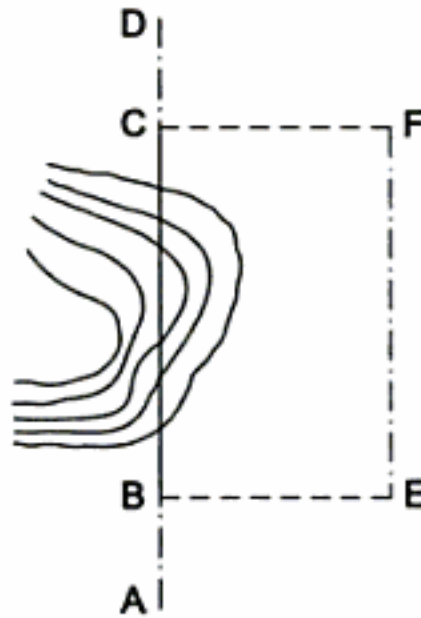

Fig. 2.31

Second method (Fig. 2.32) Let DAB be a chain line obstructed by a river. Lay off AC, of any convenient length, perpendicular to the required distance AB and lay off DC perpendicular to BC. Then, $AB = AC^2/AD$.

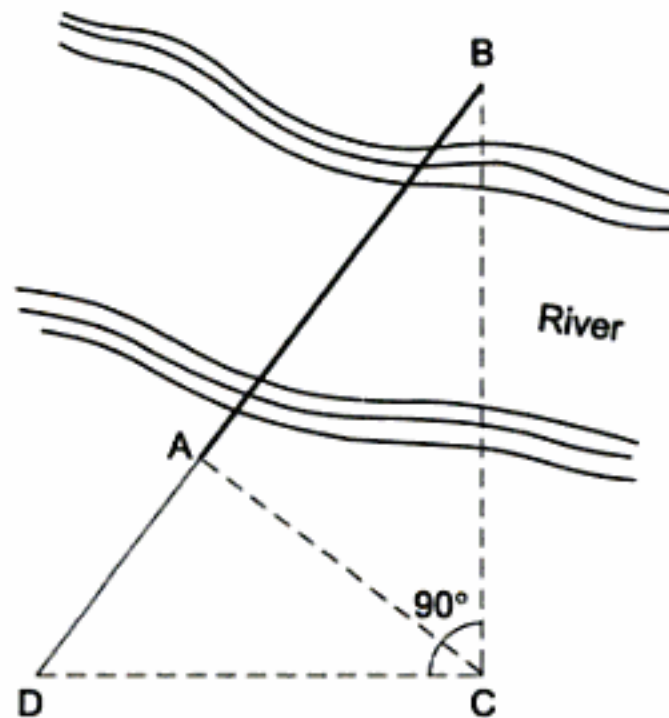

Fig. 2.32

Third method (Fig. 2.33) Let AB be a chain line obstructed by a river. Assume a point I anywhere in line with the required distance AB. Take a point H in such a way that $HJ = HI$ and $HK = HB$. Establish L in the line AH and at the same time in the line JK produced. Then $KL = AB$.

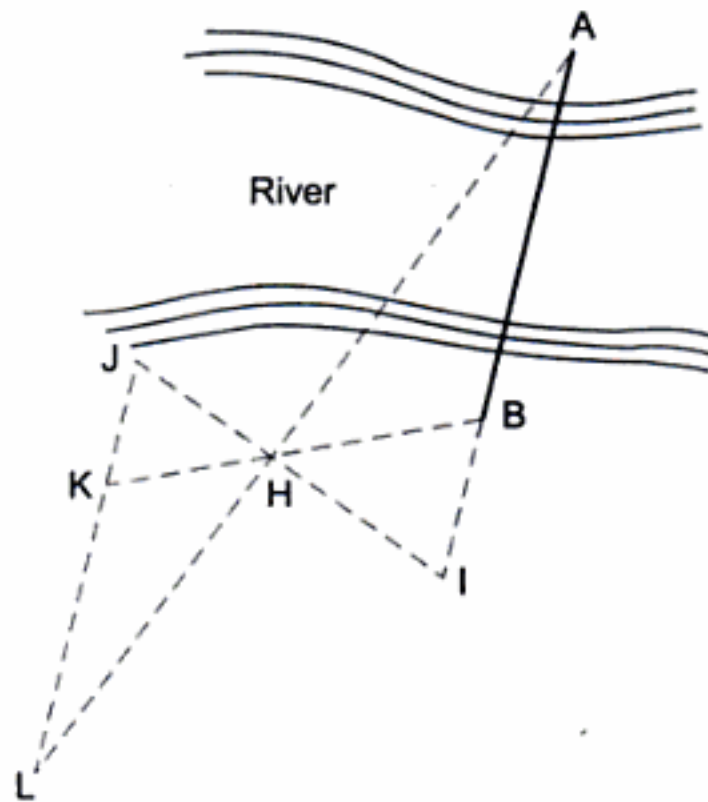

Fig. 2.33

2.18.2 Obstacles to Alignment

Let DE be a chain line obstructed by a house.

First method (Fig. 2.34) Assume a point C arbitrarily. Make $EC = CB$ and $DC = CA$. Then $AB = DE$.

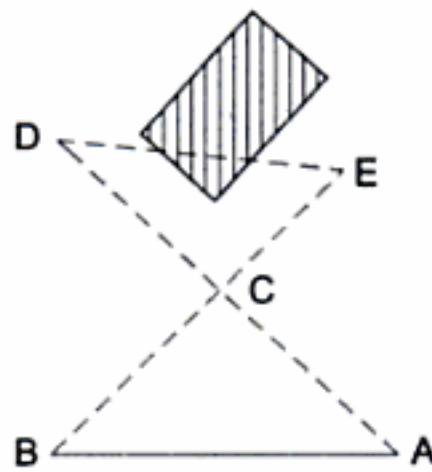

Fig. 2.34

Second method (Fig. 2.35) Establish a point F at equal distances from D and E at any convenient distance. Make $FH = FG$. Then $DE = (HG \times DF)/HF$.

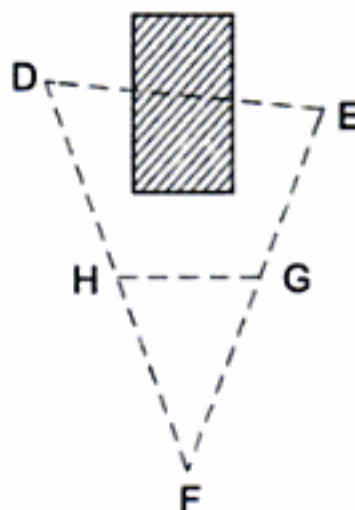

Fig. 2.35

Example 2.13 A chain line ABC crosses a river at 90° as shown in Fig. 2.36. B and C are two points located at the near and far banks, respectively. $AB = 57.73$ m, $BD = 100$ m and $\angle ABD = 90^\circ$. The whole circle magnetic bearing (W.C.B.) of C and A taken at D are 30° and 120° , respectively. Find the width of the river.

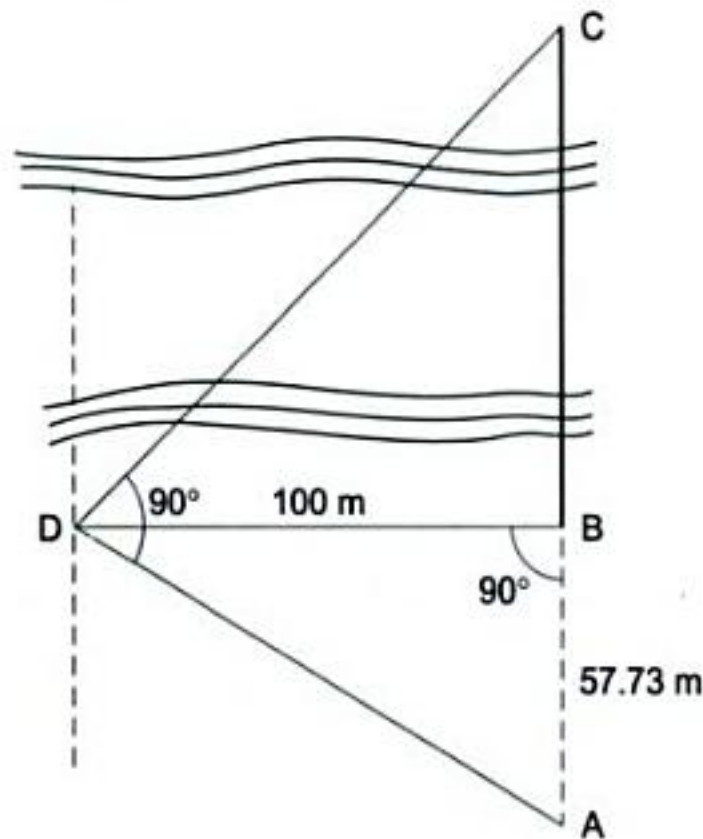

Fig. 2.36

Solution

W.C.B. of C at D = 30°

W.C.B. of A at D = 120°

$$\angle ADC = 120^\circ - 30^\circ = 90^\circ$$

Consider triangles BCD and BDA

$$\angle CBD = \angle ABD = 90^\circ$$

$$\angle BCD = \angle BDA, \text{ and } \angle BDC = \angle BAD$$

Hence, triangles BCD and BDA are similar triangles.

$$\frac{BC}{BD} = \frac{BD}{AB}$$

or
$$BC = \frac{(BD)^2}{AB} = \frac{(100)^2}{57.73} = 173.22 \text{ m}$$

Hence, width of river = 173.22 m.

Example 2.14 A big pond obstructs the chain line ab as shown in Fig. 2.37. A line al was measured on the left of the line ab for circumventing the obstacle. The length of al was 901 m. Similarly, the line am was measured on the right of the line ab whose length was 1100 m. Points m, b and l are in the same straight line. Lengths of the links bl and bm are 502 m and 548 m, respectively. Find the distance ab.

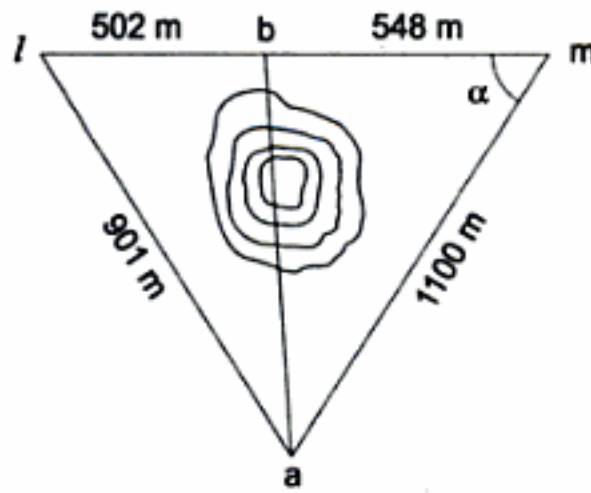

Fig. 2.37

Solution

Consider triangle alm

Let $\angle lma = \alpha$

$$\begin{aligned} \cos \alpha &= \frac{(am)^2 + (lm)^2 - (al)^2}{2(am)(lm)} \\ &= \frac{(1100)^2 + (1050)^2 - (901)^2}{2 \times 1100 \times 1050} \\ &= \frac{150.07}{231.00} = 0.6497 \end{aligned}$$

In triangle abm

$$\begin{aligned} (ab)^2 &= (bm)^2 + (am)^2 - 2(am)(bm)\cos \alpha \\ &= (548)^2 + (1100)^2 - 2 \times 1100 \times 548 \times 0.6497 \end{aligned}$$

or $ab = 852.66 \text{ m.}$

Example 2.15 A survey line ABC crossing a river at right angles cut its banks at B and C, as shown in Fig. 2.38. To determine the width BC of the river, the following operation was carried out.

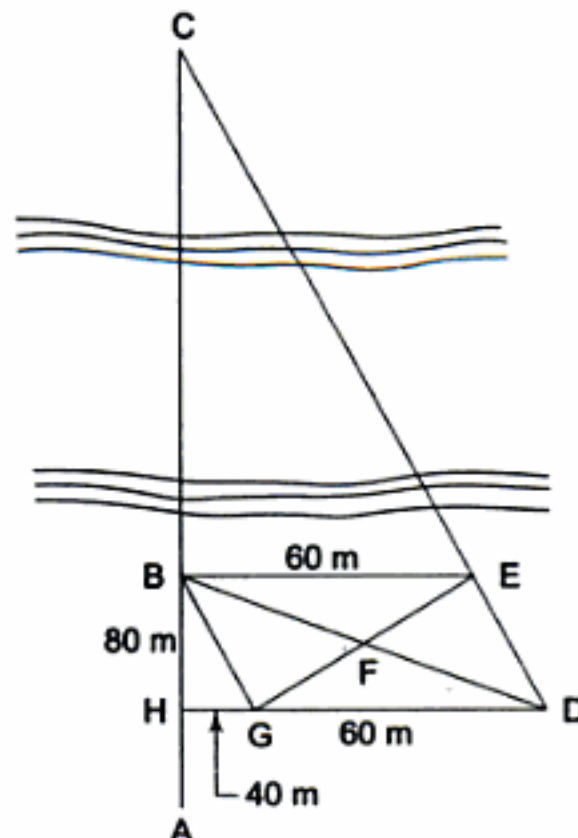

Fig. 2.38

A line BE 60 m long was set out roughly parallel to the river. Line CE was extended to D and mid-point F of DB was established. Then EF was extended to G such that FG = EF. Line DG was extended to cut the survey line ABC at H. GH and HB were measured and found to be 40 m and 80 m, respectively.

Find the width of the river.

Solution

Given $BE = 60$ m, $BH = 80$ m and $HG = 40$ m

$$GD = BE = 60 \text{ m}$$

$$HD = HG + GD$$

$$= 40 + 60$$

$$= 100 \text{ m}$$

Consider similar triangles CHD and CBE

$$CB/CH = BE/HD$$

or $CB/(CB + BH) = BE/(HG + GD)$

i.e. $CB/(CB + 80) = 60/(40 + 60) = 0.6$

$$CB = 0.6 (CB + 80)$$

$$CB (1 - 0.6) = 80 \times 0.6$$

$$CB = 80 \times 0.6/0.4$$

$$= 48/0.4$$

$$= 120 \text{ m}$$

Example 2.16 To continue a survey line AB past an obstacle, a line BC 200 m long was set out perpendicular to AB, and from C angles BCD and BCE were set out at 60° and 45° , respectively. Determine the lengths which must be chained off along CD and CE in order that ED may be in AB produced. Also determine the obstructed length.

Solution Refer to Fig. 2.39.

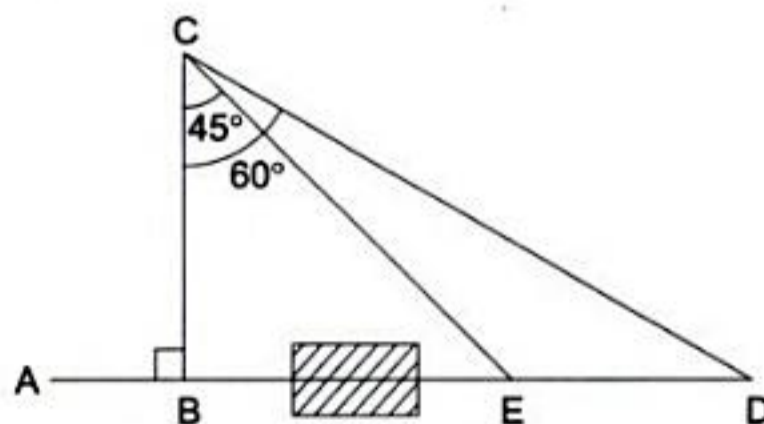

Fig. 2.39

From ΔBCD ,

$$\begin{aligned} CD &= BC \sec 60^\circ \\ &= 200 \times \sec 60^\circ \end{aligned}$$

$$= 400 \text{ m}$$

From $\triangle BCE$,

$$\begin{aligned} CE &= BC \sec 45^\circ \\ &= 200 \times \sec 45^\circ \\ &= 282.84 \text{ m} \end{aligned}$$

and

$$\begin{aligned} BC &= BC \tan 45^\circ \\ &= 200 \times \tan 45^\circ \\ &= 200 \text{ m.} \end{aligned}$$

Example 2.17 A survey line is obstructed by a high building. To prolong the line beyond the building, a perpendicular BC 150 m long, is set out at B . From C , two lines CD and CE , are set out at angles of 30° and 40° with CB , respectively. Determine the lengths CD and CE so that D and E may be on the prolongation of AB . If the chainage of B is 100 m, find the chainage of D .

Solution

From $\triangle BCD$ (Fig. 2.40)

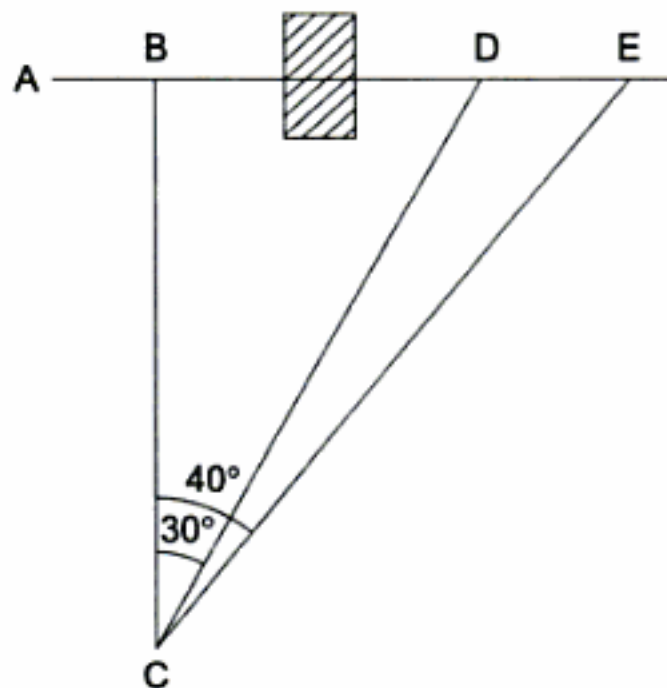

Fig. 2.40

$$CD = \frac{BC}{\cos 30^\circ} = \frac{150}{\cos 30^\circ} = 173.205 \text{ m}$$

From $\triangle BCE$

$$CE = \frac{BC}{\cos 40^\circ} = \frac{150}{\cos 40^\circ} = 195.81 \text{ m}$$

$$\begin{aligned} BD &= [CD^2 - BC^2]^{1/2} \\ &= [(173.205)^2 - (150)^2]^{1/2} \\ &= 86.602 \text{ m} \end{aligned}$$

$$\begin{aligned} \therefore \text{Chainage of D} &= \text{chainage of B} + BD \\ &= 100 + 86.602 \\ &= 186.602 \text{ m.} \end{aligned}$$

Example 2.18 A river is flowing from west to east. For determining the width of the river, two points A and B are selected on the southern bank such that distance $AB = 100$ m. Point A is west wards. The bearings at a tree C on the northern bank are observed to be 40° and 340° , respectively from A and B. Calculate the width of the river.

Solution

In $\triangle ABC$ (Fig. 2.41)

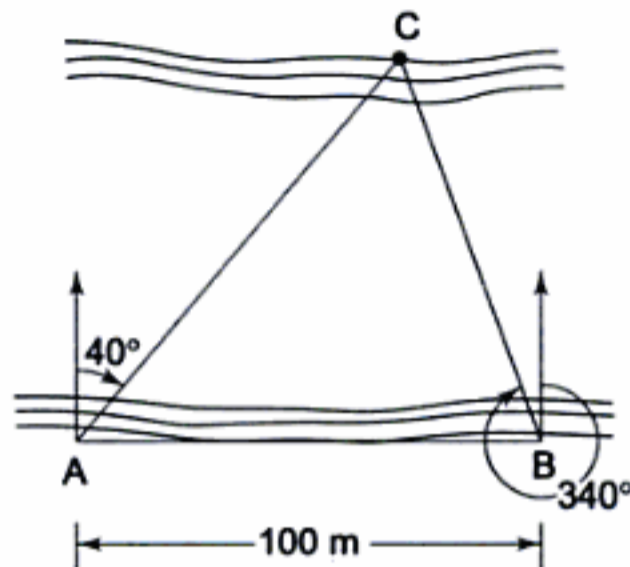

Fig. 2.41

$$\angle CAB = 90^\circ - 40^\circ = 50^\circ$$

$$\angle CBA = 340^\circ - 270^\circ = 70^\circ$$

$$\begin{aligned}\angle ACB &= 180^\circ - (\angle CAB + \angle CBA) \\ &= 180^\circ - (50^\circ + 70^\circ) \\ &= 60^\circ\end{aligned}$$

By sine rule

$$\begin{aligned}\frac{AC}{\sin ABC} &= \frac{BC}{\sin CAB} = \frac{AB}{\sin ACB} \\ AC &= \frac{AB \sin 70^\circ}{\sin 60^\circ} = \frac{100 \times 0.9396}{0.866} \\ &= 108.50 \text{ m}\end{aligned}$$

$$\begin{aligned}\text{and } BC &= \frac{AB \sin 50^\circ}{\sin 60^\circ} = \frac{76.60}{0.866} \\ &= 88.455 \text{ m}\end{aligned}$$

$$\begin{aligned}\text{Width of the river} &= AC \sin 50^\circ \\ &= 108.50 \sin 50^\circ \\ &= 83.116 \text{ m}\end{aligned}$$

$$\begin{aligned}\text{or width of the river} &= BC \sin 70^\circ \\ &= 88.455 \times \sin 70^\circ \\ &= 83.116 \text{ m.}\end{aligned}$$

$$\therefore \text{Width of the river} = 83.116 \text{ m.}$$

Exercises

- 2.1 Explain how a chain is tested and adjusted in the field.
- 2.2 Briefly describe the process of chaining.
- 2.3 Describe the various methods of chaining on a slope along with their advantages and disadvantages.
- 2.4 Describe the following with sketches:
- | | |
|--------------------|---------------------|
| (i) Line ranger | (ii) Optical square |
| (iii) Prism square | (iv) Clinometer |
- 2.5 Differentiate between the following terms:
- | | |
|------------------------------|---|
| (i) Base line and check line | (ii) Main station and tie station |
| (iii) Chainage and offset | (iv) Cumulative and compensating errors |
- 2.6 Explain the following terms: normal tension, hypotenusal allowance, cumulative error, and ranging.
- 2.7 Explain the various sources and nature of errors in chain survey.
- 2.8 Describe the various tape corrections with sketches.
- 2.9 The area of a plan of an old map plotted to a scale of 10 m to 1 cm measures 100.2 cm^2 as measured by a planimeter. The plan is found to have shrunk so that line originally 10 cm long now measures 9.7 cm. Further, the 20 m chain used was 8 cm too short. Find the true area of survey.
[Ans. 105.6438 acres]
- 2.10 An area actually measures 0.8094 hectares. How much will it measure in m^2 by a 30.48 m chain which was 20.32 cm too short at the start and 60.96 cm too long at the end of the survey?
[Ans. 7987.15 m^2]
- 2.11 The area of a piece of a land which had been surveyed with a chain was calculated to be 9562 m^2 . Of this, 8935 m^2 was the total area of the triangles and 627 m^2 was the area included between chain lines and the boundary. The 30 m chain used was found 0.05 m too long, and the 30 m tape used for measuring offsets was found 0.03 m too short from their nominal lengths. Calculate the correct area of the land.
[Ans. 9590.5 m^2]
- 2.12 A line was measured with a steel tape 30 m long, standardized at 15°C , with a pull of 100 N. Find the correction per tape length, if the temperature at the time of measurement was 20°C and the pull exerted was 160 N.
- | | |
|--|-------------------------------------|
| Weight of 1 cm^3 of steel | = 0.0786 N |
| Weight of tape | = 8 N |
| Modulus of elasticity | = $2.10 \times 10^5 \text{ N/mm}^2$ |
| Coefficient of expansion of tape/ $^\circ\text{C}$ | = 7.1×10^{-7} |
- [Ans. 0.49 mm]

- 2.13 The distance between two points P and Q measured along a slope is 250 m. Find the horizontal distance between P and Q, if
- the angle of slope is 10° ,
 - the slope is 1 in 4.5, and
 - the difference in elevation is 35 m.

[Ans. 246.20 m. 244.04 m. 247.53 m]

- 2.14 Calculate up to five decimal places, the sag correction for a 100 m tape weighing 13.0 N. It is used under a pull of 90 N and in four equal spans of 25 m each.

[Ans. 0.005433 m]

- 2.15 To what precision would you measure the offsets, if the plan of the survey is to be plotted to a scale of (i) 1 cm = 1 m and (ii) 1 cm = 10 m

[Ans. 2.5 cm, 25 cm]

- 2.16 A line 2 km long is measured with a tape of length 50 m which is standardized under no pull at 15°C . The tape in section is 3 mm wide and 1.25 mm thick. If one-half of the line is measured at temperature of 20°C and the other half at 26°C and the tape is stretched with a pull of 22 kg, find the corrected total length, given that the coefficient of expansion is 12×10^{-6} per $^\circ\text{C}$ weight of 1 cm^3 of steel = 7.7504 g and $E = 2.11 \times 10^6 \text{ kg/cm}^2$.

[Ans. 2000.384 m]

- 2.17 A steel tape is 30 m long between the end graduations at a temperature of 15°C when it is laid horizontally on the ground. Its sectional area equals 0.065 cm^2 , total weight is 15.8 N and the coefficient of expansion being 11.5×10^{-6} per $^\circ\text{C}$. The tape is stretched on two supports 30 m apart and is also supported in the middle, the three supports being at the same level. Calculate the actual length between the end graduations under the following conditions: temperature = 25°C , pull on the tape = 100 N, and $E = 2.11 \times 10^5 \text{ N/mm}^2$.

[Ans. 29.991 m]

- 2.18 A base line measured with a steel tape gives an approximate length of 1000 m. Compute the correct length of the base line at mean sea level when the pull at the standardization equals 15 kg. The applied pull is 23 kg. The cross-sectional area of tape is 0.0645 cm^2 and $E = 2.11 \times 10^6 \text{ kg/cm}^2$. Temperatures T_m and T_o are 35°C and 15°C , respectively. The difference in level of the two ends of base line is 2 m. Radius of earth, $R = 6400 \text{ km}$. Elevation of base line above mean sea level = 1000 m.

[Ans. 1000.1405 m]

Objective-type Questions

- 2.1 In chain surveying, field work is limited to
- linear measurements only
 - angular measurements only

- (c) both linear and angular measurements
 - (d) none of the above
- 2.2 The accuracy of measurement in chain surveying, does not depend upon
- (a) length of the offset
 - (b) scale of the plotting
 - (c) importance of the features
 - (d) general layout of the chain lines
- 2.3 Chain survey is well adopted for
- (a) small surveys in open ground
 - (b) small surveys with ups and downs
 - (c) large area with simple details
 - (d) large area with crowded details
- 2.4 In a metric chain, number of links per metre can be
- (a) 2
 - (b) 5
 - (c) 8
 - (d) 10
- 2.5 Cross-staff is used for
- (a) setting out right angles
 - (b) measuring horizontal angles
 - (c) both (a) and (b)
 - (d) measuring the bearing of lines
- 2.6 In chain surveying, perpendiculars to the chain line are set out by
- (a) a theodolite
 - (b) a prismatic compass
 - (c) a clinometer
 - (d) an optical square
- 2.7 Ranging is defined as
- (a) measuring the distance from starting point
 - (b) establishing intermediate points on a chain line
 - (c) the distance between end points
 - (d) a point on chain line
- 2.8 Chainage in chain survey means
- (a) the distance between end stations
 - (b) the perpendicular distance of the object from the chain line
 - (c) the distance of the object along the chain line from the zero end of the chain
 - (d) any distance measured by chain in field
- 2.9 Main stations in chain survey are the points
- (a) lying in the area enclosed by survey lines
 - (b) connected by main survey lines
 - (c) on main survey lines to cover the local details
 - (d) on main survey lines to check the accuracy of the survey work
- 2.10 Oblique offsets are used to
- (a) locate broken boundaries
 - (b) locate boundary lines of property
 - (c) to check the accuracy of the plotted work in chain survey
 - (d) none of the above
- 2.11 Which of the following methods results in higher accuracy for measuring horizontal distance on rough grounds:
- (a) chaining
 - (b) taping
 - (c) tacheometry
 - (d) all of the above

- 2.12 While measuring horizontal distance with chain on hills, it is better to measure the distance by
 (a) stepping down slope (b) stepping up slope
 (c) both of the above (d) none of the above
- 2.13 The maximum tolerances in a 20 m and 30 m chain are
 (a) ± 2 mm ± 8 mm (b) ± 3 mm ± 5 mm
 (c) ± 5 mm ± 8 mm (d) ± 8 mm ± 5 mm
- 2.14 Pick up the correct statement(s).
 (i) A metric chain is 30 m long
 (ii) A metric chain is 20 m long
 (a) (i) is correct
 (b) (ii) is correct
 (c) both (i) and (ii) are correct
 (d) both are wrong
- 2.15 Prolongation of a chain line across an obstruction in chain survey is done by
 (a) making angular observations
 (b) drawing perpendiculars with a chain
 (c) solution of triangle
 (d) all of the above
 (e) only (a) and (b)
- 2.16 While measuring a line between two stations A and B intervened by a raised ground,
 (a) the vision gets obstructed
 (b) the chaining gets obstructed
 (c) vision and chaining both get obstructed
 (d) none of the above
- 2.17 A well-conditioned triangle should not have angles more than
 (a) 30° (b) 120° (c) 45° (d) 60°
- 2.18 Offsets are
 (a) short measurements from the chain line
 (b) ties or check lines which are perpendicular to the chain line
 (c) chain lines which go out of alignment
 (d) both (a) and (b)
- 2.19 The correction to be applied to each 30 m chain length along slope is
 (a) $30(1 - \sec \alpha)$ m (b) $30(\sec \alpha - 1)$ m
 (c) $30(1 - \cos \alpha)$ m (d) $30(\cos \alpha - 1)$ m
- 2.20 A tape of length l and weight w N/m is suspended at its end with a pull of P newtons. The required sag correction is
 (a) $lw^2/24P^2$ (b) $l^2w^3/24P^2$
 (c) $l^2w^2/24P^2$ (d) $lw^2/24P$
- 2.21 Compensating or accidental errors are proportional to
 (a) $L^{1/2}$ (b) $L^{1/3}$ (c) L (d) $1/L$

- 2.22 Check lines (proof lines) in chain surveying are essentially required
- (a) to plot the chain line
 - (b) to plot the offsets
 - (c) to indicate the correctness of the survey work
 - (d) to increase the efficiency of the surveyor
- 2.23 Perpendicularity of an offset may be judged by eye if the length of the offset is less than
- (a) 5 m
 - (b) 10 m
 - (c) 15 m
 - (d) 20 m
- 2.24 Which of the following instruments is generally used for base line measurement?
- (a) Chain
 - (b) Metallic tape
 - (c) Steel tape
 - (d) Invar tape
- 2.25 Invar tape is made of an alloy of
- (a) copper and steel
 - (b) brass and nickel
 - (c) brass and steel
 - (d) steel and nickel
- 2.26 The length of a chain is measured from the
- (a) centre of one handle to the centre of other handle
 - (b) outside of one handle to the outside of other handle
 - (c) outside of one handle to the inside of other handle
 - (d) inside of one handle to the inside of other handle
- 2.27 The angle of intersection of the two plain mirrors of the optical square is
- (a) 30°
 - (b) 45°
 - (c) 60°
 - (d) 90°
- 2.28 Which of the following angles can be set out with the help of French cross-staff?
- (a) 45° only
 - (b) 90° only
 - (c) both of the above
 - (d) any angle
- 2.29 If the length of a chain is found to be short on testing, it can be adjusted by
- (a) straightening the links
 - (b) removing one or more small circular rings and by placing bigger rings
 - (c) closing the joints of the rings, if opened
 - (d) all of the above
- 2.30 If the length of a chain is found to be too long on testing, it can be adjusted by
- (a) closing the opened joints of rings
 - (b) reshaping elongated links
 - (c) removing one or more circular rings
 - (d) replacing the worn out rings
 - (e) all of the above
- 2.31 The position of a point can be fixed accurately by
- (a) cross-staff
 - (b) optical square

- (c) clinometer (d) perpendicular offset

2.32 Figure 2.42 shows one of the brass tallies of a 30 m chain. The distance of this tally from the nearest end of the chain is



Fig. 2.42

- (a) 5 m (b) 10 m (c) 15 m (d) 20 m
- 2.33 Which of the following is an obstacle to chaining but not to ranging?
 (a) River (b) Hillock
 (c) Building (d) None of the above
- 2.34 A building is an obstacle to
 (a) chaining but not to ranging
 (b) ranging but not to chaining
 (c) both chaining and ranging
 (d) neither chaining nor ranging
- 2.35 Which of the following is not used in measuring perpendicular offsets?
 (a) Line ranger (b) Tape
 (c) Optical square (d) Cross-staff
- 2.36 During chaining along a straight line with a 20 m chain, the leader of the party has 4 arrows in his hand while the follower has 6. Distance of the follower from the starting point is
 (a) 4 chains (b) 6 chains
 (c) 8 chains (d) 12 chains
- 2.37 The main difference between an optical square and a prism square is
 (a) the difference in the principle of working
 (b) that an optical square is more accurate than a prism square
 (c) that no adjustment is required in a prism square since the angle between the reflecting surfaces cannot be changed
 (d) all of the above
- 2.38 The allowable length of an offset depends upon the
 (a) degree of accuracy required
 (b) method of setting out the perpendicular and nature of ground
 (c) scale of plotting
 (d) all of the above
- 2.39 Normal tension is that pull which
 (a) is used at the time of standardizing the tape
 (b) neutralizes the effect due to sag
 (c) makes the correction due to sag equal to zero
 (d) makes the correction due to pull equal to zero

- 2.40 The correction for sag is
 (a) always additive
 (b) always subtractive
 (c) always zero
 (d) sometimes additive and sometimes subtractive
- 2.41 The permissible error in chaining for measurement with a chain on rough or hilly ground is
 (a) 1 in 100 (b) 1 in 250
 (c) 1 in 500 (d) 1 in 1000
- 2.42 Correction for slope is given by
 (a) $h^2/2L$ (b) h/L (c) $h/2L$ (d) $2h^2/L$
- 2.43 The required slope correction for a length of 30 m, along a gradient of 1 in 20 is
 (a) 3.75 cm (b) 0.375 cm (c) 27.5 cm (d) 2.75 cm
- 2.44 If the length of a chain line along a slope of α is l , the required slope correction is
 (a) $2l \cot^2 \alpha/2$ (b) $2l \sin^2 \alpha/2$
 (c) $l \tan^2 \alpha/2$ (d) $l \cos^2 \alpha/2$
- 2.45 Match the following
- | | |
|------------------------------------|--|
| (I) Correction for standard length | (A) $C_a = LC/l$ |
| (II) Correction for tension | (B) $C_p = \frac{P - P_0}{AE} L$ |
| (III) Correction for temperature | (C) $C_t = \alpha (T_m - T_0)L$ |
| (IV) Sag correction | (D) $C_{sa} = \frac{W^2 L^3}{24 P^2}$ |
| (V) Reduction to m.s.l. | (E) $C_R = Lh/R$ |
| (VI) Normal tension | (F) $P = \frac{0.204 W \sqrt{AE}}{\sqrt{P - P_0}}$ |
- where L = measured length,
 C = correction applied, and
 l = nominal length of tape
- (a) I-A, II-B, III-C, IV-D, V-E, VI-F
 (b) I-C, II-D, III-B, IV-A, V-F, VI-E
 (c) I-B, II-A, III-F, IV-C, V-E, VI-D
 (d) none of the above
- 2.46 For setting out an offset at an angle of 45° with a chain line, the instrument used is
 (a) an optical square (b) an open cross-staff
 (c) a French cross-staff (d) a prism square
- 2.47 A pair of slots at right angles to each other are provided in
 (a) cross-staff (b) arrow
 (c) ranging rod (d) offset rod
- 2.48 The limiting length of an offset does not depend upon
 (a) accuracy of the work

- (b) method of setting out perpendicular
 - (c) scale of plotting
 - (d) the number of features to be surveyed
- 2.49 Pick up the correct statement.
- (a) The cost of making a horizontal measurement decreases with an increase in the desired precision.
 - (b) A base line may be measured with a precision of 1 in 10^6
 - (c) Tie stations are generally located on the intersection of two main survey lines
 - (d) Base line is a line lying at the base of the area to be surveyed by a chain
- 2.50 Pick up the correct statement(s).
- (i) Offset is the distance from the foot of an object to the chain line
 - (ii) Perpendicular offsets may have infinite length
- (a) only (i) is correct
 - (b) only (ii) is correct
 - (c) both (i) and (ii) are correct
 - (d) none of the above
- 2.51 Pick up the correct statement.
- (a) A revenue chain is 66 ft long.
 - (b) Gunter devised the invar tape.
 - (c) A tally is used to facilitate observation in an optical square.
 - (d) A brass ring is provided at every metre length in a metric chain.
- 2.52 While testing a chain, a tension of 80 N is applied at the ends of a
- (a) 20 m chain
 - (b) 30 m chain
 - (c) both (a) and (b)
 - (d) Gunter's chain
- 2.53 Pick up the correct statement.
- (a) Invar is an alloy of steel (36%) and nickel (64%).
 - (b) A steel tape is soft and easily deforms as compared to invar tape.
 - (c) Metallic tape is made by weaving linen with brass wires.
 - (d) Steel tapes can be used comfortably in grounds with weeds and vegetation.
- 2.54 Pick up the correct statement.
- (a) A ranging rod is provided with a stout open ring recessed hook.
 - (b) An offset cannot be laid with a French cross-staff.
 - (c) Optical squares and cross-staffs are used for the same purpose.
 - (d) Clinometer is used to measure the directions of survey lines in chain survey.
- 2.55 Pick up the correct statement(s).
- (i) In the process of chaining, the leader inserts the arrows and the follower picks them up.
 - (ii) A leader follows the instructions of the follower.
- (a) only (i) is correct.
 - (b) only (ii) is correct.

- (c) both (i) and (ii) are correct.
 (d) none of the above.
- 2.56 Pick up the incorrect statement.
 (a) It is easy to measure distance down the slopes.
 (b) Incorrect plumbing, while measuring distances on slopes, is a cumulative error.
 (c) Sag correction is a cumulative error.
 (d) Incorrect holding of chain at arrow is a compensating error.
- 2.57 Pick up the correct statement.
 (a) Sag correction may be positive or negative.
 (b) The limiting length of an offset is independent of the scale of plotting.
 (c) Error due to laying of the direction of offset is negligible.
 (d) The slope correction is always subtractive.
- 2.58 Pick up the correct statement(s).
 (i) The length of the offsets in a chain survey is always limited to reduce error in plotted work.
 (ii) Perpendicular offsets are used for filling in details.
 (a) only (i) is correct.
 (b) only (ii) is correct.
 (c) both (i) and (ii) are correct.
 (d) none is correct.
- 2.59 Pick up the correct statement(s).
 (i) Optical square is better than a prism square.
 (ii) In both the optical and prism squares, the principle of operation is same.
 (a) only (i) is correct.
 (b) only (ii) is correct.
 (c) both (i) and (ii) are correct.
 (d) none is correct.
- 2.60 Which of the following is the most precise instrument for measuring horizontal distances.
 (a) Chain (b) Tape
 (c) Tacheometer (d) Tellurometer

— **Answers to Objective-type Questions** —

- | | | | | |
|----------|----------|----------|----------|----------|
| 2.1 (a) | 2.2 (d) | 2.3 (a) | 2.4 (b) | 2.5 (a) |
| 2.6 (d) | 2.7 (b) | 2.8 (c) | 2.9 (b) | 2.10 (b) |
| 2.11 (c) | 2.12 (a) | 2.13 (c) | 2.14 (c) | 2.15 (d) |
| 2.16 (a) | 2.17 (b) | 2.18 (d) | 2.19 (c) | 2.20 (a) |
| 2.21 (a) | 2.22 (c) | 2.23 (c) | 2.24 (d) | 2.25 (d) |
| 2.26 (b) | 2.27 (b) | 2.28 (c) | 2.29 (a) | 2.30 (e) |

2.31 (d)	2.32 (a)	2.33 (a)	2.34 (c)	2.35 (a)
2.36 (b)	2.37 (c)	2.38 (d)	2.39 (b)	2.40 (b)
2.41 (b)	2.42 (a)	2.43 (a)	2.44 (b)	2.45 (a)
2.46 (c)	2.47 (d)	2.48 (d)	2.49 (b)	2.50 (a)
2.51 (d)	2.52 (c)	2.53 (c)	2.54 (c)	2.55 (c)
2.56 (b)	2.57 (d)	2.58 (c)	2.59 (b)	2.60 (d)

Chapter 3

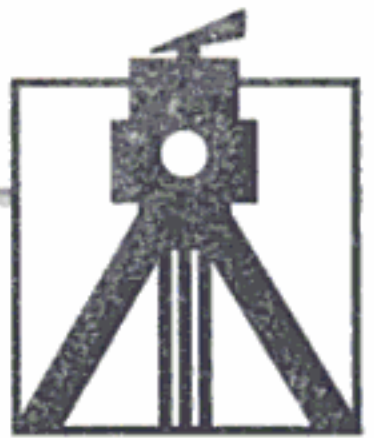

Compass Surveying

3.1 INTRODUCTION

Surveying is concerned with the relative location of points on, above or below the surface of the earth. It therefore becomes necessary to start from known points on a line. If the location of two points is known, a third point may be located by measuring the distances from the already located points. The relative position of the third point is at times also expressed in terms other than the distance alone. In such cases, direction may be used for the location of a point by any of the following methods:

1. By measuring its distance from one of the given points and its direction from the other point.
2. By measuring its distance and direction from any of the two known points.
3. By measuring its direction from each of the two known points.

The direction of the survey lines is measured with the help of an instrument known as *compass*. The diameter of the graduated ring of the compass determines its size. A 10 cm compass means a compass, whose graduated ring has a diameter of 10 cm. The direction of survey lines may be defined in two ways: (1) relative to each other, (2) relative to some reference direction.

In the first case, the directions are expressed in terms of angles between two consecutive lines, measured with a theodolite. In the second case, these are expressed in terms of bearings, measured with a compass.

Compass, being light and portable, is most suited for reconnaissance and exploratory survey. It is particularly advantageous when the survey lines have to be short due to obstructions or irregularities of details. Some of the applications and uses of compass survey are:

1. To find out the magnetic bearing of a line
2. To fill in details
3. To find the direction during night marching

4. Tracing streams
5. Plotting irregular shore lines
6. Reconnaissance survey
7. Clearings in roads

3.2 DEFINITIONS

Meridian It is the fixed direction in which the bearings of survey lines are expressed.

Bearing It is the horizontal angle between the reference meridian and the survey line measured in clockwise or anticlockwise direction. The bearing of a line is obtained with the aid of whole circle bearing (azimuth), quadrantal bearing (reduced bearing) and grid bearing (in geodetic survey).

True Meridian The true meridian passing through a point on the earth surface is the line in which a plane passing through the given point (say A) and the north and south poles, intersects the surface of the earth. It represents the true north-south direction at the place (Fig. 3.1).

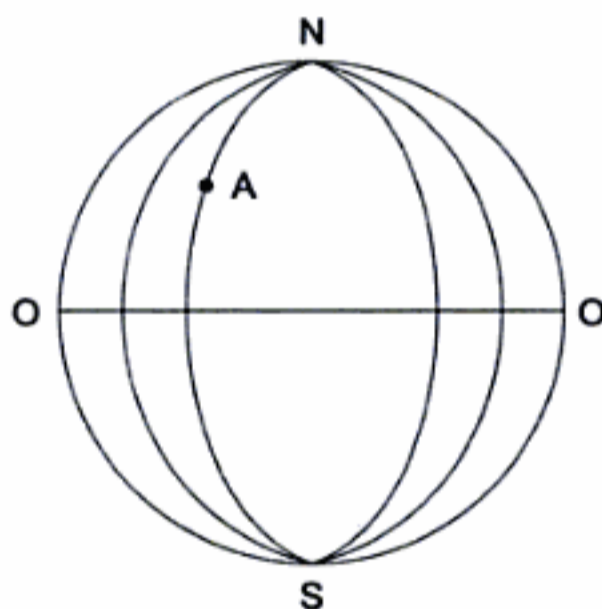

Fig. 3.1 True meridian

The direction of true meridian at a station is invariable, i.e. its direction is always the same. The invariance of the true meridian, therefore, is of considerable importance for large surveys. It may save much time in retracing of the lines during final location and construction. The true meridians through various stations are not parallel, but converge at the poles. For small surveys, they are however assumed to be parallel to each other. The determination of its direction through a station involves astronomical observations.

True Bearing The horizontal angle measured clockwise between the true meridian and the line is called true bearing of the line.

Grid Meridian Grid meridian is the reference meridian for a country on a national survey map. For survey of a country, the true meridian of a central place

is regarded as the reference meridian. All the other meridians in the country are assumed to be parallel to the grid meridian.

Grid Bearing The horizontal angle which a line makes with the grid meridian is called grid bearing.

Magnetic Meridian It is the direction indicated by a freely suspended and balanced magnetic needle unaffected by local attractive forces. The location of the magnetic poles is constantly changing, hence the direction of magnetic meridian also changes. However, the magnetic meridian is employed as a line of reference on rough surveys.

Magnetic Bearing The horizontal angle which a line makes with the magnetic meridian is called magnetic bearing. It varies with time.

Arbitrary Meridian It is any convenient direction, usually from a survey station to some well-defined permanent object. The first line of survey at times is also taken as arbitrary meridian.

Arbitrary Bearing The horizontal angle measured with respect to the arbitrary meridian is called arbitrary bearing.

3.3 TYPES OF COMPASS

Surveying compass may be classified as trough compass, tubular compass, prismatic compass and surveyor compass.

3.3.1 Trough Compass

It consists of a long magnetic needle in a narrow rectangular box. The needle of trough compass consists of a long, narrow, magnetized bar of steel, pointed at both ends with the usual agate bearing at the centre. At each end of the box is a block of metal, on which is engraved a zero line and a very short graduated arc extending about 5° on either side of the zero mark.

When it is used in conjunction with a plane table, the sides of the box are used as a ruler to plot the north direction. When fitted on a theodolite (generally attached by screws to the side of one of the standards), it is used to align the telescope in the meridian.

3.3.2 Tubular Compass

A tubular compass is an improved version of a trough compass. A trough compass does not lend itself to very precise setting owing to parallax arising from the difficulty of ensuring that the eye is in the vertical plane of the needle. This difficulty is overcome by the use of a tubular compass.

In a tubular compass, the magnetic needle is contained in a tube, at one end of which an eye piece and a diaphragm carrying a glass plate with vertical rulings is fitted. This is nearly in the same plane as one end of the needle. The reticule being

suitably illuminated by a reflector, the observer on looking through the eye piece, sees the end of the needle without any parallax.

3.3.3 Prismatic Compass

1. It consists of a circular box about 100 mm in diameter.
2. There is a broad magnetic needle balanced on a hard steel pointed pivot (Fig. 3.2).

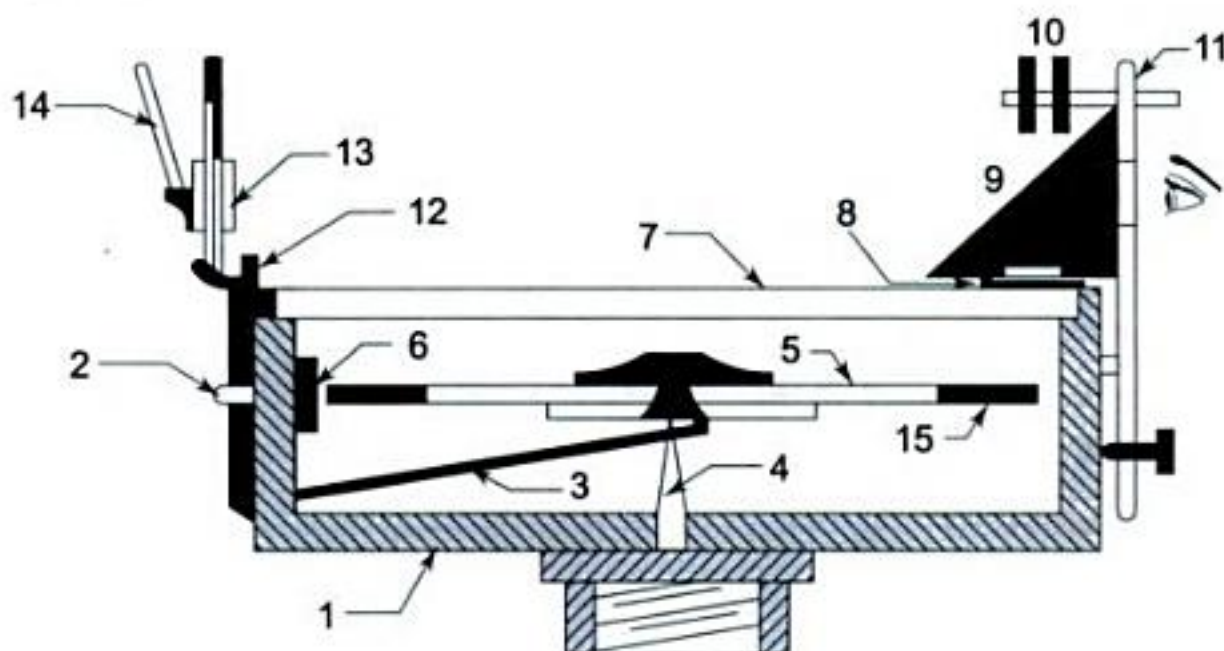

- | | | | |
|-----------------|---------------|--------------------|-----------------|
| 1. Box | 2. Brake pin | 3. Lifting lever | 4. Pivot |
| 5. Needle | 6. Spring | 7. Glass cover | 8. Prism cap |
| 9. Prism | 10. Sun glass | 11. Eye vane | 12. Lifting pin |
| 13. Object vane | 14. Mirror | 15. Graduated ring | |

Fig. 3.2 Prismatic compass

3. An aluminium ring, graduated to degrees and half degrees is attached to the needle. A prism is provided on the observer's side to read the bearing. The ring is graduated from the south end of the needle. The observations are run clockwise round to 360° with zero placed at south as shown in Fig. 3.5 (b). This is done to facilitate direct reading of the bearings. The figures on the graduated ring are engraved inverted as they are viewed through the prism.
4. When the needle is balanced on the pivot, it orients itself in the magnetic meridian and the north and south ends of the ring face the N-S direction.
5. The object vane carries a vertical hair of fine silk thread attached to a suitable frame.
6. The sight vane consists of a vertical slit cut into the upper assembly of the prism. The two vanes are hinged at the box in diagonally opposite directions.
7. The object vane is sometimes provided with a hinged mirror which can be raised upwards or lowered downwards and can also be slid, if required, to sight the objects too high or too low. Figure 3.3 explains the use of the mirror.

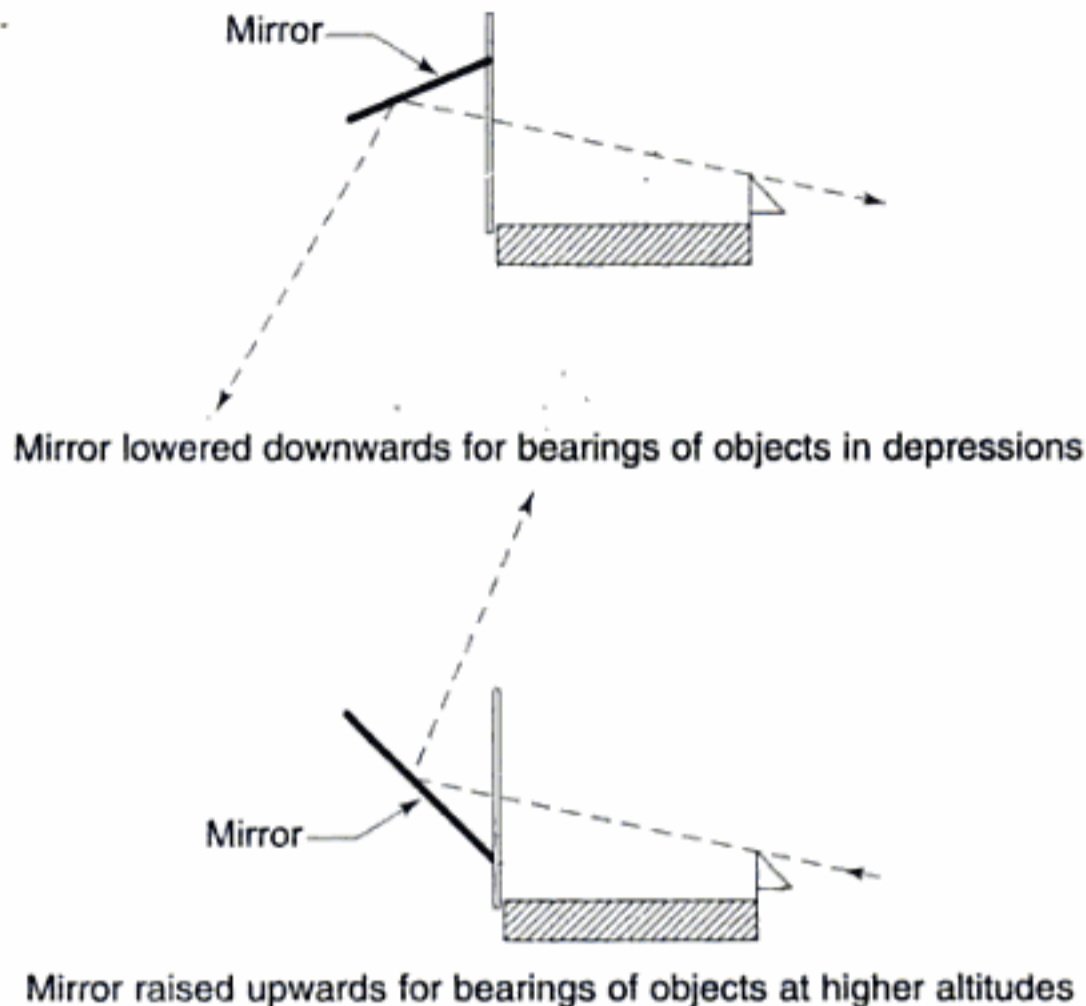

Fig. 3.3 Use of sliding mirror

8. Sunglasses are provided on the prism to sight luminous objects.
9. The inverted figures in the graduated ring below the prism can be read erect after being reflected from the hypotenuse side of the prism, when the observer looks horizontally into the prism.
10. The two perpendicular faces of the prism are made convex, so that it also acts as a magnifier.
11. When not in use, the object vane may be folded on the glass lid. It presses against a lever which lifts the needle off the pivot, thus preventing undue wear of the pivot point.
12. Breaking pin, provided at the base of the object vane is used to dampen the oscillations of the needle to facilitate the reading.
13. A prismatic compass reads the whole circle bearing of the lines of objects directly.

3.3.4 Surveyor Compass

Surveyor compass acquires its name from its extensive use by surveyors. But the prismatic compass has now replaced it as it is light, compact, and handy. It is similar in construction to the prismatic compass except for a few differences as follows:

1. The graduated ring is attached to the circular box and not to the magnetic needle (Fig. 3.4).
2. The edge bar type magnetic needle floats freely over the pivot and is not attached to the ring. When the magnetic needle is lowered to its pivot, it will come to rest pointing north.
3. The eye vane consists of metal vane with a fine sight hole.

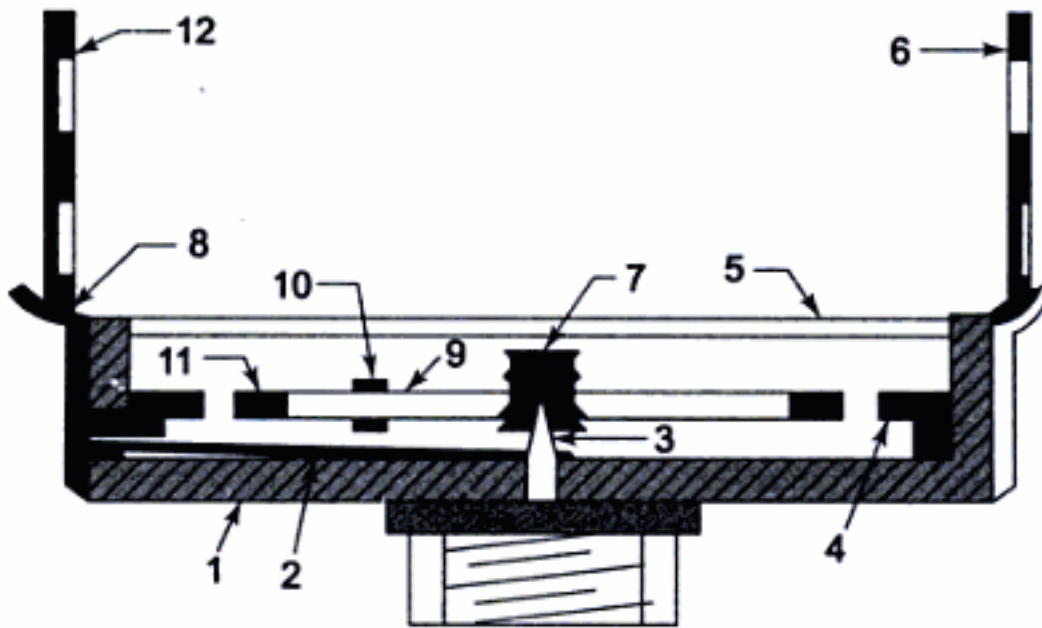

- | | | |
|---------------------------|------------------|--------------------|
| 1. Box | 2. Lifting lever | 3. Pivot |
| 4. Circular graduated arc | 5. Glass top | 6. Sight vane |
| 7. Jewel bearing | 8. Lifting pin | 9. Magnetic needle |
| 10. Rider | 11. Metal pin | 12. Object vane |

Fig. 3.4 Surveyor compass

4. As the compass box is turned, the letters N, E, S, and W turn with it, but the needle continues to point towards the north and gives a reading which is dependent on the position of the graduated circle.
5. The 0° is placed at both north and south directions and 90° is marked at east and west directions.
6. The east and west markings are interchanged from their normal position as shown in Fig. 3.5(a) to read the bearings in the proper quadrant. Suppose the compass is rotated to point $N30^\circ 30' E$. In reading the bearing, the north end of the needle will be found between the letters N and E or $30^\circ 30'$ from N towards E. If W had been on the left in place of E, as one naturally expects it to be, the north end of the needle would fall between N and W, which might lead to the mistake calling the bearing to be NW instead of NE.

A comparison of the construction, principle and working of surveyor and prismatic compasses is given in Table 3.1.

3.4 TEMPORARY ADJUSTMENTS OF COMPASS

The adjustments required to be made every time the compass is set up are called its temporary adjustments and are as follows:

3.4.1 Centring

A tripod is placed over the station with its legs spread well apart so that it is at a workable height. The compass is fixed on the tripod. It is then centred over the station, where the bearing is to be taken (i.e. the centre of the compass, the pivot is brought exactly above the ground station). A plumb bob is hung from the centre

Table 3.1 Comparison of Surveyor Compass and Prismatic Compass

S.No.	Item	Surveyor compass	Prismatic compass
1.	Magnetic needle	The needle is of edge bar type.	The needle is a broad needle.
2.	Graduated ring	<p>(i) The graduated ring is attached to the box and rotates along with line of sight.</p> <p>(ii) The graduations have 0° at N and S and 90° at E and W. The letters E and W are interchanged from their true positions in order to read the bearing in its proper quadrant (Fig. 3.5 (a)). As the graduated ring is attached to the box, it moves with the sight. If the bearing of a line in the first quadrant is to be measured, since the letters E and W are reversed (Fig. 3.5(a)) from their natural positions, the proper quadrant NE will be read</p> <p>(iii) The graduations are engraved erect, since the graduated ring is read directly.</p>	<p>(i) The graduated ring is attached with the needle and does not rotate with line of sight.</p> <p>(ii) The graduations have 0° at S, 90° at W, 180° at N and 270° at E (Fig. 3.5(b)). When the needle points north, the reading under the prism should be zero. It is so because the prism is placed exactly opposite the object vane, i.e. on observer's side, and the south end will be under the prism while the needle points north. Hence, the zero is placed at the south end and then ring is graduated clockwise from it.</p> <p>(iii) Graduations are engraved inverted since the graduated ring is read through the prism.</p>

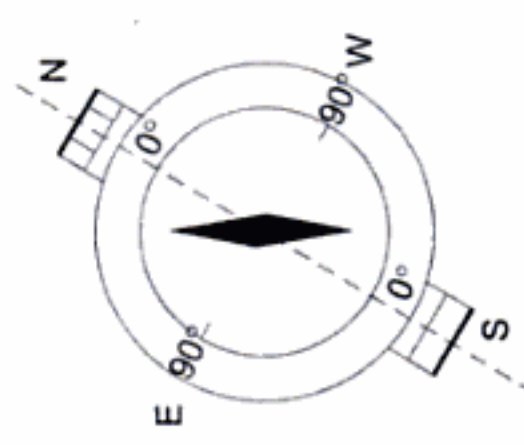

Fig. 3.5 (a)

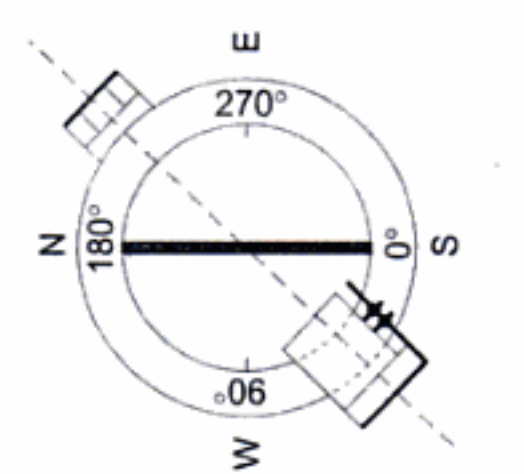

Fig. 3.5 (b)

(Contd).

		<i>Surveyor compass</i>	<i>Prismatic compass</i>
3.	Reading system	<p>(i) The readings are taken directly by seeing through top of the box glass.</p> <p>(ii) Sighting and reading cannot be done Simultaneously.</p>	<p>(i) The readings are taken with the help of a prism, provided at the eye vane.</p> <p>(ii) Sighting and reading can be done simultaneously.</p>
4.	Tripod	The instrument cannot be used without a tripod.	The instrument can be held in hand also while making the observations.
5.	Vanes	The eye vane consists of small vane with a small slit.	The eye vane consists of a metal vane with a large slit.

of compass. In case the arrangement for a plumb bob is not provided, a stone is dropped from below the compass and it should fall on the peg marking the ground station.

3.4.2 Levelling

The compass is levelled by eye judgement. This is essential so that the graduated ring swings freely. Sometimes, in surveyor's compass, two plate levels at right angles are also provided to level the instrument. The levelling is achieved by a ball and socket arrangement which is adjusted till the bubbles become central in both the plate levels.

3.4.3 Focussing the Prism

This adjustment is done only in a prismatic compass. The prism is moved up or down till the figures and graduations are seen clearly.

3.5 DESIGNATION OF BEARINGS

There are two systems commonly used to express bearings and are as follows:

3.5.1 Whole Circle Bearing System (W.C.B. System)

In this system, the bearing of a line is always measured clockwise from the north point of the reference meridian towards the line right round the circle, e.g. ϕ_1 , ϕ_2 , etc. as shown in Fig. 3.6. The angle thus measured between the reference meridian and the line is called the *whole circle bearing* of the line. It will have values between 0° and 360° .

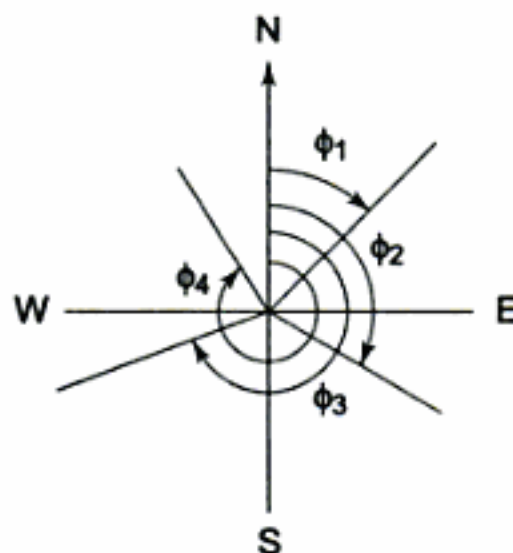

Fig. 3.6 Whole circle bearings

A prismatic compass and a theodolite observe the W.C.B., which is also considered as an azimuth. The azimuth of a line is basically the angle measured clockwise from the starting point, usually north in plane survey. In astronomical observations and in most of the governmental surveys, the true south is taken as the starting point. However, measuring the azimuth from north has a distinct advantage that the algebraic signs will accord with the directions to which the surveyor is accustomed in trigonometric computations.

3.5.2 Quadrantal Bearing System (Q.B. System)

In this system, the bearings of lines are measured clockwise (α , γ) or anticlockwise (β , δ) from north or south, whichever is nearer to the line as shown in Fig. 3.7.

Quadrantal bearing of

OA : N α E

OB : S β E

OC : S γ W

OD : N δ W

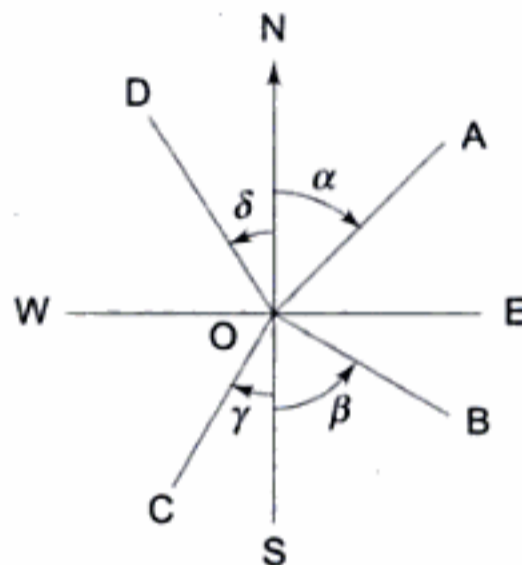

Fig. 3.7 Quadrantal bearings

Example 3.1

- (a) Convert the following whole circle bearings to quadrantal bearings.
- | | |
|------------------------|-----------------------|
| (i) $56^{\circ}20'$ | (ii) $170^{\circ}05'$ |
| (iii) $218^{\circ}30'$ | (iv) $272^{\circ}50'$ |
- (b) Convert the following quadrantal bearings into whole circle bearings.
- | | |
|--------------------------|-------------------------|
| (i) N $10^{\circ}00'E$ | (ii) S $30^{\circ}14'E$ |
| (iii) S $02^{\circ}10'W$ | (iv) N $18^{\circ}20'W$ |

Solution

- | | |
|-----------------------------------|---|
| (a) (i) W.C.B. = $56^{\circ}20'$ | Q.B. = N $56^{\circ}20'E$ |
| (ii) W.C.B. = $170^{\circ}05'$ | Q.B. = $180^{\circ} - 170^{\circ}05' = S9^{\circ}55'E$ |
| (iii) W.C.B. = $218^{\circ}30'$ | Q.B. = $218^{\circ}30' - 180^{\circ} = S38^{\circ}30'W$ |
| (iv) W.C.B. = $272^{\circ}50'$ | Q.B. = $360^{\circ} - 272^{\circ}50' = N87^{\circ}10'W$ |
| (b) (i) Q.B. = N $10^{\circ}00'E$ | W.C.B. = $10^{\circ}00'$ |
| (ii) Q.B. = S $30^{\circ}14'E$ | W.C.B. = $180^{\circ} - 30^{\circ}14' = 149^{\circ}46'$ |
| (iii) Q.B. = S $02^{\circ}10'W$ | W.C.B. = $180^{\circ} + 02^{\circ}10' = 182^{\circ}10'$ |
| (iv) Q.B. = N $18^{\circ}20'W$ | W.C.B. = $360^{\circ} - 18^{\circ}20' = 341^{\circ}40'$ |

3.6 REDUCED BEARING

When the whole circle bearing of a line exceeds 90° , it must be reduced to the corresponding angle less than 90° . This angle is known as reduced bearing. The concept of reduced bearing facilitates computations in traverse surveying (Chapter 5).

Case	W.C.B. between	R.B.	Quadrant
1.	$0^\circ - 90^\circ$	W.C.B.	NE
2.	$90^\circ - 180^\circ$	$180^\circ - \text{W.C.B.}$	SE
3.	$180^\circ - 270^\circ$	$\text{W.C.B.} - 180^\circ$	SW
4.	$270^\circ - 360^\circ$	$360^\circ - \text{W.C.B.}$	NW

3.7 FORE BEARING AND BACK BEARING

3.7.1 Fore Bearing (F.B.)

The bearing of a line in the direction of progress of the survey is called the *fore* or *forward* bearing.

3.7.2 Back Bearing (B.B.)

The bearing of a line in the opposite direction of progress of the survey is known as *back* or *reverse* bearing.

The bearing of a line is indicated in the order in which the line is lettered. Thus, the bearing from A to B is the fore bearing α of the line AB, whereas the bearing of line AB in the direction B to A is its back bearing β (Fig. 3.8).

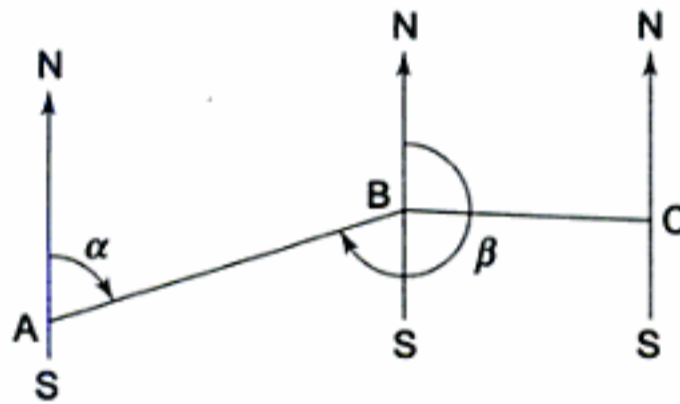

Fig. 3.8 Fore and back bearings

3.7.3 Relationship between F.B. and B.B.

- (i) **W.C.B. system** If the fore bearing of a line is known then,
 Back bearing = Fore bearing $\pm 180^\circ$

✓ **Note** Plus sign is used if the fore bearing is less than 180° , and minus sign if it is more than 180° .

- (ii) **Q.B. system** The fore and back bearings are numerically equal but are in opposite directions, i.e. N is replaced by S or vice versa and E is replaced by W or vice versa. For example, if the fore bearing of a line is $N30^\circ E$, its back bearing will be $S30^\circ W$.

3.8 CALCULATION OF INCLUDED ANGLES FROM BEARINGS

The included angle between two lines may either be an interior angle or an exterior one. When traversing is done anticlockwise, the included angles are interior, whereas in the case of clockwise traversing, these are the exterior ones. These are always measured clockwise from the preceding line to the forward line.

If the bearings of adjacent lines are known, then the included angles may be calculated as explained below:

(i) Given W.C.B. of lines (Fig. 3.9).

In a clockwise close traverse OAB, OA is the forward line (next line) and BO is the previous line at station O.

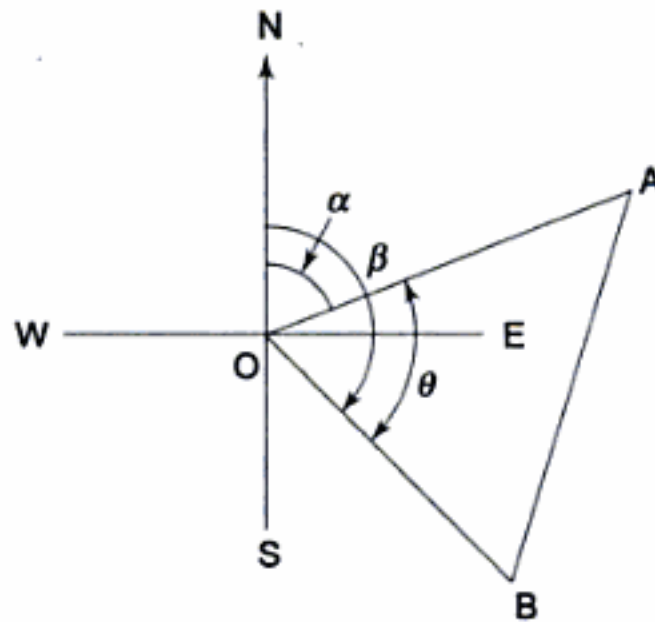

Fig. 3.9

Let W.C.B. of the line OA = α

and W.C.B. of the line OB = β

The included angle $\angle AOB = \theta$

$$\begin{aligned} &= \text{line} = \text{F.B. of the forward line} - \text{B.B. of the previous} \\ &= \alpha - \beta \\ &= \text{a negative value} \end{aligned}$$

Note If in the process of calculating the included angle, if the value is a negative one (as above), add 360° to get the actual included angle which will be the exterior included angle.

In case the traversing is done in anticlockwise direction, say OBA, then OB is the forward line and AO is the previous line.

The included angle $\angle AOB = \theta$

$$\begin{aligned} &= \text{F.B. of the forward line} - \text{B.B. of the previous line} \\ &= \beta - \alpha \\ &= \text{a positive value (interior included angle)} \end{aligned}$$

(ii) Given Q.B. of lines (Fig. 3.10).

The lines may be plotted in the respective quadrant and then the included angles are computed. Let the included angle be θ .

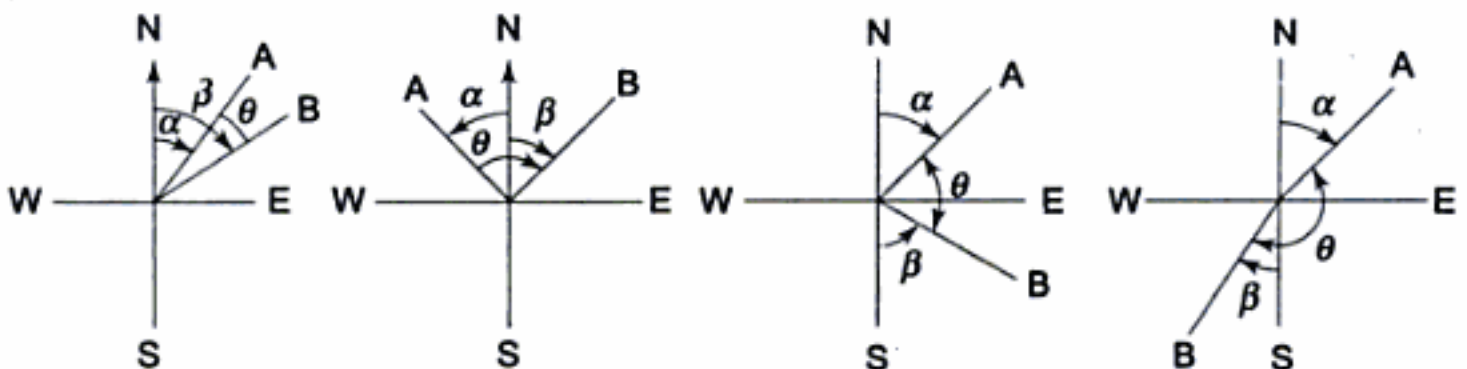

Fig. 3.10

- (a) When bearings are measured in the same side of the common meridian,
 $\theta = \beta - \alpha$
- (b) When bearings are measured in the opposite side of the common meridian,
 $\theta = \beta + \alpha$
- (c) When bearings are measured in the same side of the different meridians,
 $\theta = 180^\circ - (\alpha + \beta)$
- (d) When bearings are measured in the opposite side of the different meridians,
 $\theta = 180^\circ - (\alpha - \beta)$

Example 3.2 Determine the value of included angles in a closed compass traverse ABCD (Fig. 3.11) conducted in clockwise direction, given the following fore bearings of the respective lines.

Line	F.B.
AB	40°
BC	70°
CD	210°
DA	280°

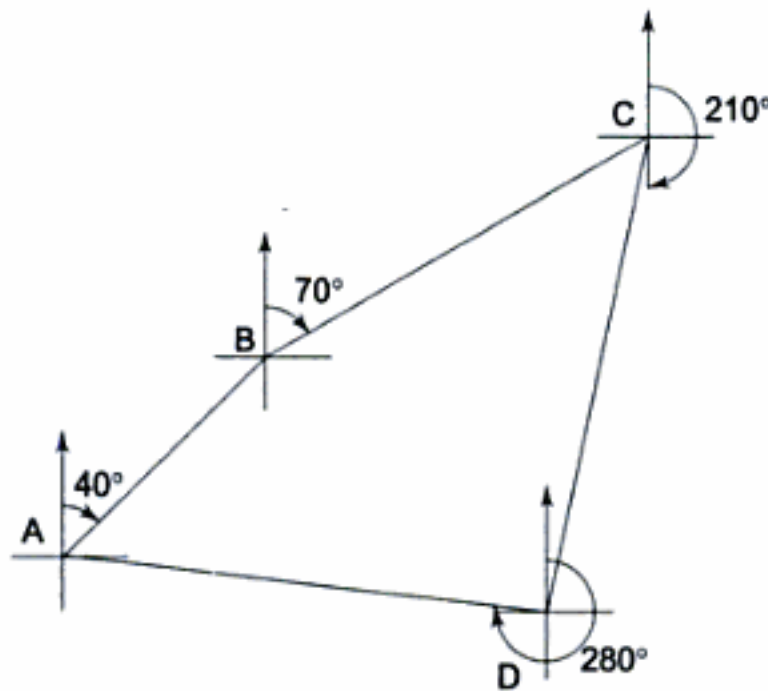

Fig. 3.11

Solution As the traversing is done in clockwise direction, the included angles will be the exterior angles.

Included angle = F.B. of next line – B.B. of the previous line.

$$\begin{aligned}\angle A &= \text{F.B. of AB} - \text{B.B. of DA} \\ &= 40^\circ - (280^\circ - 180^\circ) + 360^\circ \\ &= 300^\circ\end{aligned}$$

$$\begin{aligned}\angle B &= \text{F.B. of BC} - \text{B.B. of AB} \\ &= 70^\circ - (40^\circ + 180^\circ) + 360^\circ \\ &= 210^\circ\end{aligned}$$

$$\begin{aligned}\angle C &= \text{F.B. of C.D.} - \text{B.B. of BC} \\ &= 210^\circ - (180^\circ + 70^\circ) + 360^\circ \\ &= 320^\circ\end{aligned}$$

$$\begin{aligned}\angle D &= \text{F.B. of DA} - \text{B.B. of CD} \\ &= 280^\circ - (210^\circ - 180^\circ) \\ &= 250^\circ\end{aligned}$$

Theoretical sum of included angles $= (2n + 4) 90^\circ = 1080^\circ$

$$\begin{aligned}\text{Also, sum of calculated included angles} &= \angle A + \angle B + \angle C + \angle D \\ &= 300^\circ + 210^\circ + 320^\circ + 250^\circ \\ &= 1080^\circ\end{aligned}$$

Note In the process of computation, if the included angle is negative, then 360° is added to it, as has been done in the case of angle A, B and C.

Example 3.3 Following are the bearings taken in a closed compass traverse.

Line	F.B.	B.B.
AB	S37°30'E	N37°30'W
BC	S43°15'W	N44°15'E
CD	N73°00'W	S72°15'E
DE	N12°45'E	S13°15'W
EA	N60°00'E	S59°00'W

Compute the interior angles and correct them for observational errors.

Solution Refer to Fig. 3.12. Convert the quadrantal bearings to whole circle bearings.

Lines	F.B.	B.B.
AB	142°30'	322°30'
BC	223°15'	44°15'
CD	287°00'	107°45'
DE	12°45'	193°15'
EA	60°00'	239°00'

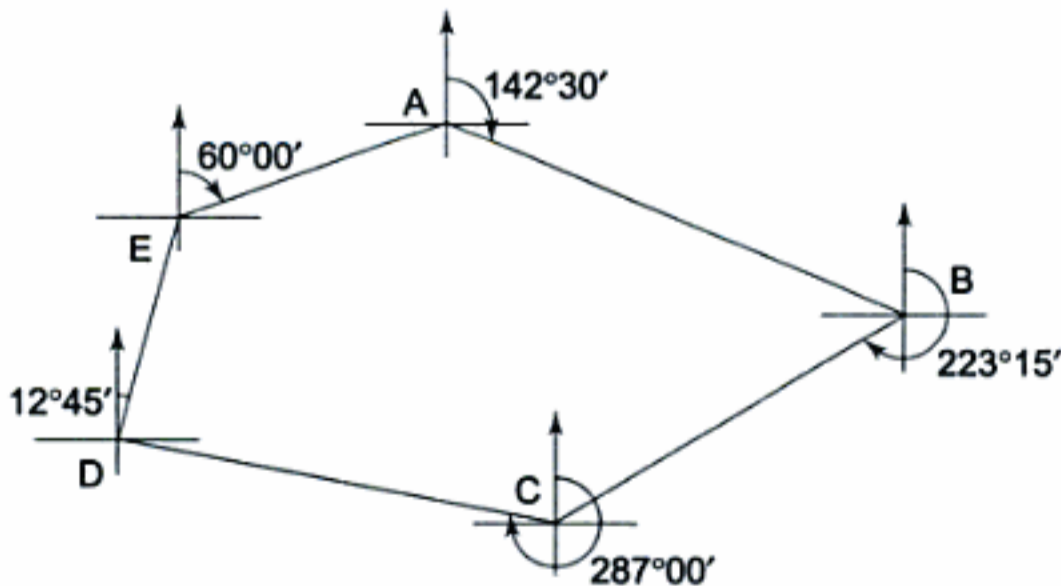

Fig. 3.12

As the traversing is done in the clockwise direction, the included angles will be exterior.

Included angle = F.B. of next line – B.B. of previous line

$$\begin{aligned}\angle A &= \text{F.B. of AB} - \text{B.B. of EA} = 142^\circ 30' - 239^\circ 00' \\ &= -96^\circ 30' = -96^\circ 30' + 360^\circ = 263^\circ 30'\end{aligned}$$

$$\begin{aligned}\angle B &= \text{F.B. of BC} - \text{B.B. of AB} = 223^{\circ}15' - 322^{\circ}30' = -99^{\circ}15' \\ &= -99^{\circ}15' + 360^{\circ} = 260^{\circ}45'\end{aligned}$$

$$\angle C = \text{F.B. of CD} - \text{B.B. of BC} = 287^{\circ}00' - 44^{\circ}15' = 242^{\circ}45'$$

$$\begin{aligned}\angle D &= \text{F.B. of DE} - \text{B.B. of CD} = 12^{\circ}45' - 107^{\circ}45' \\ &= -95^{\circ}00' = -95^{\circ} + 360^{\circ} = 265^{\circ}00'\end{aligned}$$

$$\begin{aligned}\angle E &= \text{F.B. of EA} - \text{B.B. of DE} = 60^{\circ}00' - 193^{\circ}15' \\ &= -133^{\circ}15' = -133^{\circ}15' + 360^{\circ} = 226^{\circ}45'\end{aligned}$$

$$\begin{aligned}\text{Sum of angles} &= \angle A + \angle B + \angle C + \angle D \\ &= 263^{\circ}30' + 260^{\circ}45' + 242^{\circ}45' + 265^{\circ}00' + 226^{\circ}45' \\ &= 1258^{\circ}45'\end{aligned}$$

Theoretical sum $(2 \times 5 + 4) 90^{\circ} = 1260^{\circ}$

$$\text{Error} = 1260^{\circ} - 1258^{\circ}45' = 1^{\circ}15' = 75'$$

$$\text{Correction for each angle} = + 75'/5 = + 15'$$

Hence, corrected included angles are:

$$\angle A = 263^{\circ}30' + 15' = 263^{\circ}45'$$

$$\angle B = 260^{\circ}45' + 15' = 261^{\circ}00'$$

$$\angle C = 242^{\circ}45' + 15' = 243^{\circ}00'$$

$$\angle D = 265^{\circ}00' + 15' = 265^{\circ}15'$$

$$\angle E = 226^{\circ}45' + 15' = 227^{\circ}00'$$

Check: sum = 1260°

3.9 CALCULATION OF BEARINGS FROM INCLUDED ANGLES

Knowing the bearing of a line and the various included angles of a traverse, the bearings of other lines may be calculated as below:

Let the observed fore bearing of a line AB be θ and the included angle with the next adjacent line be α (Fig. 3.13)

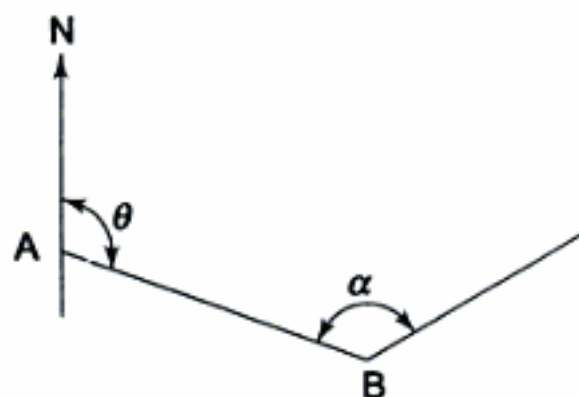

Fig. 3.13 Bearing from included angles

The fore bearing of the next line is equal to the F.B. of the previous line plus included angle.

Hence, for the bearing of the next line, the following statement may be made: "Add the included angle measured clockwise to the bearing of the previous line".

If the sum is:

more than 180° , deduct 180°

more than 540° , deduct 540°

less than 180° , add 180° .

- ✓ **Notes** (i) In a closed traverse running in anticlockwise direction, the observed included angles are interior angles.
 (ii) In a closed traverse running in clockwise direction, the observed included angles are exterior angles.
 (iii) Included angles are measured clockwise from the preceding line to the forward line.

Example 3.4 The following angles were observed in the clockwise direction in an open traverse.

$$\angle ABC = 124^\circ 15'$$

$$\angle BCD = 156^\circ 30'$$

$$\angle CDE = 102^\circ 00'$$

$$\angle DEF = 95^\circ 15'$$

$$\angle EFG = 215^\circ 45'$$

The magnetic bearing of the line AB was $241^\circ 30'$. What would the bearing of the line FG?

Solution Refer to Fig. 3.14.

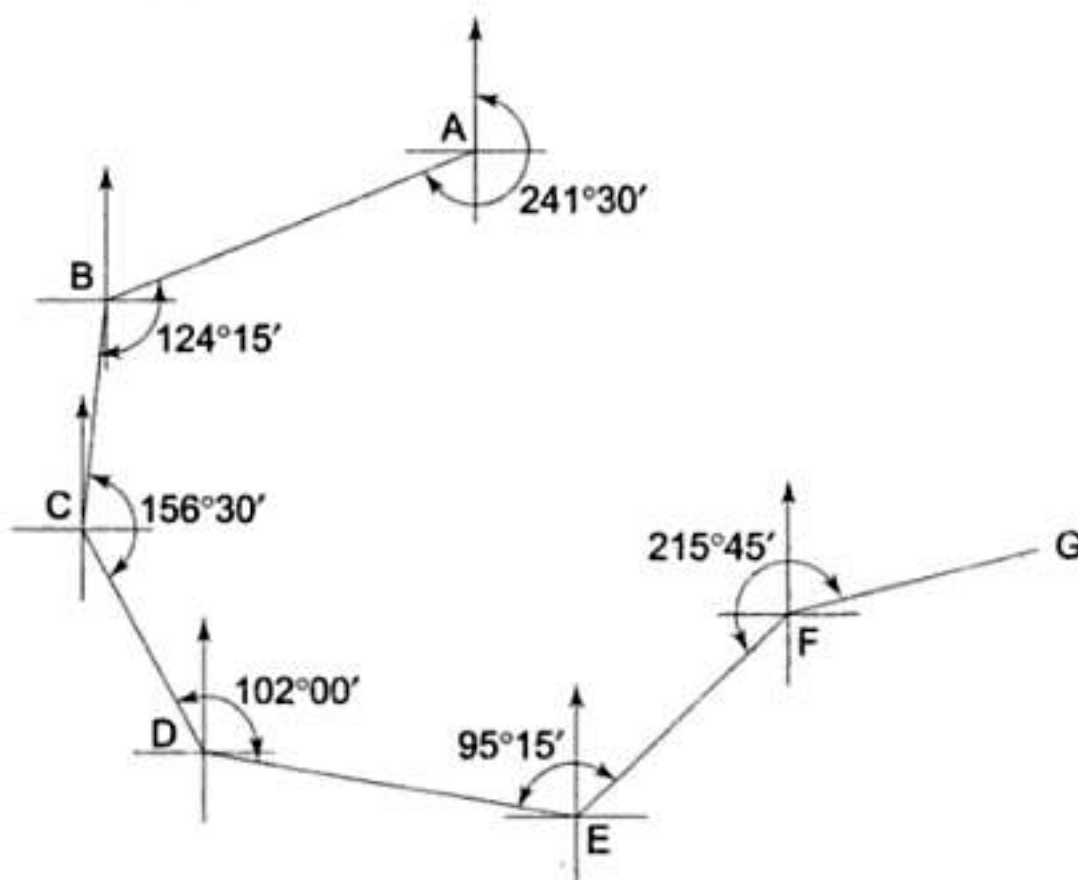

Fig. 3.14

For a clockwise traverse,

$$\text{F.B. of a line} = \text{F.B. of previous line} + \text{clockwise included angle}$$

$$\text{Given F.B. of AB} = 241^{\circ}30'$$

$$\begin{aligned}\text{F.B. of BC} &= \text{F.B. of AB} + \angle ABC \\ &= 241^{\circ}30' + 124^{\circ}15' \\ &= 365^{\circ}45' \\ &= 365^{\circ}45' - 180^{\circ} \\ &= 185^{\circ}45'\end{aligned}$$

$$\begin{aligned}\text{F.B. of CD} &= \text{F.B. of BC} + \angle BCD \\ &= 185^{\circ}45' + 156^{\circ}30' \\ &= 342^{\circ}15' - 180^{\circ} \\ &= 162^{\circ}15'\end{aligned}$$

$$\begin{aligned}\text{F.B. of DE} &= \text{F.B. of CE} + \angle CDE \\ &= 162^{\circ}15' + 102^{\circ}00' \\ &= 264^{\circ}15' \\ &= 264^{\circ}15' - 180^{\circ} \\ &= 84^{\circ}15'\end{aligned}$$

$$\begin{aligned}\text{F.B. of EF} &= \text{F.B. of DE} + \angle DEF \\ &= 84^{\circ}15' + 95^{\circ}15' \\ &= 179^{\circ}30' \\ &= 179^{\circ}30' + 180^{\circ} \\ &= 359^{\circ}30'\end{aligned}$$

$$\begin{aligned}\text{F.B. of FG} &= \text{F.B. of EF} + \angle EFG \\ &= 359^{\circ}30' + 215^{\circ}45' \\ &= 575^{\circ}15' - 540^{\circ} \\ &= 35^{\circ}15'\end{aligned}$$

Example 3.3 Three ships A, B and C started sailing from Bombay at the same time. The speed of all the three ships was the same at 30 km/h. Their bearings were measured and found to be N70°E, S60°E and S10°E, respectively (Fig. 3.15). After an hour the captain of ship B, determined the bearings of other two ships with respect to his own ship and calculated the distances. Calculate the bearings and distances which might have been determined by the captain of ship B.

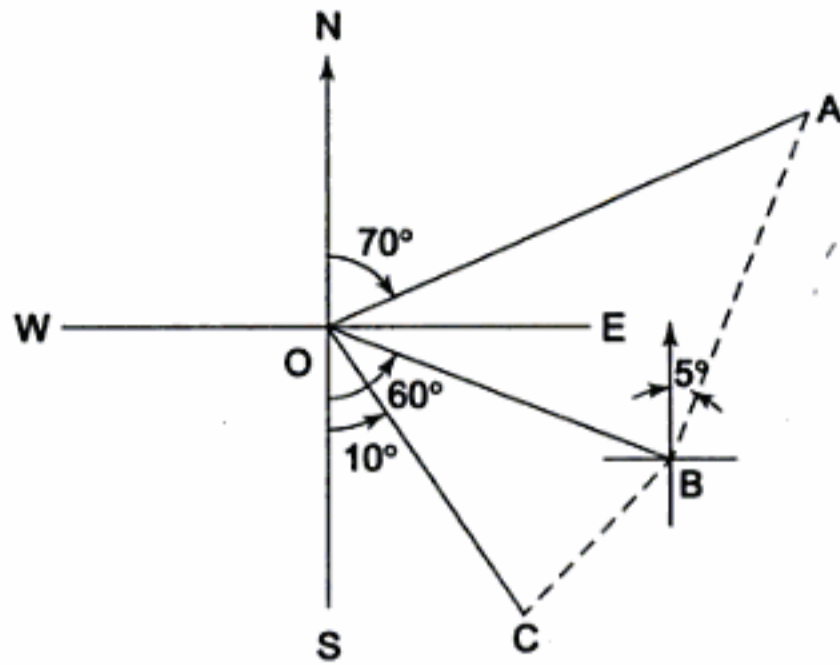

Fig. 3.15

Solution Speed of the ships = 30 km/h

After one hour

$$OA = OB = OC = 30 \text{ km}$$

$$\angle BAO = \angle OBA$$

and

$$\angle OCB = \angle OBC$$

$$\angle AOB = 180^\circ - 70^\circ - 60^\circ = 50^\circ$$

and

$$\angle COB = 60^\circ - 10^\circ = 50^\circ$$

$$\begin{aligned} \angle OAB = \angle OBA = \angle OBC = \angle OCB \\ = (180^\circ - 50^\circ)/2 = 65^\circ \end{aligned}$$

$$\begin{aligned} \text{Bearing of OB} &= \text{S}60^\circ\text{E} \\ &= 120^\circ \end{aligned}$$

$$\begin{aligned} \text{Bearing of BA} &= \text{F.B. of OB} + \angle OBA \\ &= 120^\circ + 65^\circ \\ &= 185^\circ \\ &= 185^\circ - 180^\circ \\ &= 5^\circ \end{aligned}$$

Hence, bearing of BA = N5°E

$$\begin{aligned} \text{Bearing of BC} &= \text{F.B. of OB} + \angle OBC \\ &= 120^\circ + (360^\circ - 65^\circ) \\ &= 415^\circ \\ &= 415^\circ - 180^\circ \\ &= 235^\circ \\ &= \text{S}55^\circ\text{W} \end{aligned}$$

$$\text{Bearing of BC} = \text{S}55^\circ\text{W}$$

In triangle OAB, from sine rule

$$\frac{AB}{\sin 50^\circ} = \frac{OA}{\sin 65^\circ} = \frac{OB}{\sin 65^\circ}$$

$$\begin{aligned} AB &= 30 \times \frac{\sin 50^\circ}{\sin 65^\circ} \\ &= 25.36 \text{ km} \end{aligned}$$

Since,

$$BC = BA$$

$$BC = 25.36 \text{ km}$$

3.10 MAGNETIC DECLINATION

The earth's magnetic poles are continually changing their positions relative to the geographical poles due to which the magnetic meridian of the earth also changes and results in declination.

It may be defined as the horizontal angle between true north and magnetic north at the time of observation. If, at the time of observation, the magnetic meridian is on the eastern side of the true meridian, the angle of declination is said to be the *eastern* or *positive* declination. On the other hand, if the magnetic meridian is on the western side of the true meridian, it is said to be *western* or *negative* declination. When true and magnetic meridian coincide, the declination is zero.

$$\text{True bearing} = \text{magnetic bearing} \pm \text{magnetic declination E/W}$$

Note (i) Use plus sign, if declination is in the east and minus sign, if declination is in the west.

Lines joining the places of equal magnetic declination are known as *isogonic* lines and those joining the places of zero declination are termed as *agonic lines*. On the agonic lines, the magnetic needle defines true as well as magnetic north.

3.10.1 Variation of Magnetic Declination

The declination at any place keeps on changing from time to time. These variations may be classified as follows:

- (a) **Secular variation** The magnetic meridian swings like a pendulum. It swings in one direction for about 100 – 150 years, gradually comes to rest, and then swings in other direction. This is known as secular variation. The causes of the secular variation are not well understood.
- (b) **Annual variation** It is the change in the declination at a place over a period of 1 year. It is caused because of the rotation of earth about sun. It is found that the annual variation is about 1 – 2 min.
- (c) **Diurnal variation** It is the change in the declination at a place in 24 hr. It is due to the rotation of earth about its own axis. The amount of variation is from a fraction of a minute to over 12 and is due to the following:

- (i) geographical position of the place (lesser near equator and increases towards the poles).
- (ii) the time of the day (more in day).
- (iii) season of the year (more in summers).
- (iv) the year of the cycle of secular variation.

(d) Irregular variation The variation caused due to magnetic disturbances or storms are listed under irregular variation. In general, the value may be of the order of 1° .

3.10.2 Purpose of Magnetic Declination

Most of the original land survey has been in terms of magnetic bearings. During re-running the survey lines, in a future time to check the accuracy of the work or to locate the direction, the observed bearings may be corrected if the magnetic declination at the time of original survey and at the time of re-survey are known.

Example 3.6 The magnetic bearing of line PQ is $124^\circ 35'$. Find its true bearing, if the magnetic declination is $10^\circ 10' W$.

Solution True bearing of line = magnetic bearing \pm magnetic declination E/W.
Since, magnetic meridian is to the west.

$$\begin{aligned}\text{True bearing} &= 124^\circ 35' - 10^\circ 10' \\ &= 114^\circ 25'\end{aligned}$$

Example 3.7 The magnetic bearing of line PQ is $S40^\circ E$ and the magnetic declination is $8^\circ 5' E$. What is the true bearing of the line?

Solution The W.C.B. of line PQ = $180^\circ - 40^\circ = 140^\circ$
True bearing of PQ = magnetic bearing \pm magnetic declination E/W
 $= 140^\circ + 8^\circ 5'$
 $= 148^\circ 5'$

Example 3.8 The magnetic bearing of a line in MNNIT, Allahabad was found to be $N60^\circ 30' W$ in 1992, when the declination was $5^\circ 10' E$. Find its present magnetic bearing, if declination is $3^\circ W$.

Solution Magnetic bearing of the line in 1992 = $N60^\circ 30' W$
W.C.B. = $360^\circ - 60^\circ 30'$
 $= 299^\circ 30'$
True bearing = magnetic bearing \pm magnetic declination E/W
 $= 299^\circ 30' + 5^\circ 10'$
 $= 304^\circ 40'$

Present declination is $3^\circ W$

$$\text{True bearing} = \text{magnetic bearing} \pm \text{magnetic declination E/W}$$

$$304^{\circ}40' = \text{magnetic bearing} - 3^{\circ}$$

$$\begin{aligned} \text{or, Magnetic bearing} &= 307^{\circ}40' \\ &= \text{N}52^{\circ}20'\text{W} \end{aligned}$$

Example 3.9 The magnetic bearing of sun at noon was 170° . Calculate the magnetic declination.

Solution True bearing = magnetic bearing \pm magnetic declination E/W
True bearing of sun at noon is 180° .

$$\begin{aligned} \text{Declination} &= \text{true bearing} - \text{magnetic bearing} \\ &= 180^{\circ} - 170^{\circ} \\ &= 10^{\circ} \end{aligned}$$

As the declination is eastward, it is positive. Hence, magnetic declination is 10°E .

Example 3.10 The true bearing of a T.V. tower T at MNNIT Campus, Allahabad, as observed from a station A near the survey laboratory was $358^{\circ}00'$ and the magnetic bearing of same was $8^{\circ}00'$. The fore bearing of lines AB, AC and AD, when measured with a prismatic compass was found to be $290^{\circ}00'$, $340^{\circ}00'$, and $30^{\circ}00'$, respectively. Find the true fore bearing of lines AB, AC and AD.

$$\begin{aligned} \text{Solution Declination at A} &= \text{true bearing} - \text{magnetic bearing} \\ &= 358^{\circ} - (360^{\circ} + 8^{\circ}) \\ &= -10^{\circ}00' \\ &= 10^{\circ}00' \text{ W} \end{aligned}$$

$$\begin{aligned} \text{(i) Line AB, true bearing} &= \text{magnetic bearing of AB} - \text{magnetic declination} \\ &= 290^{\circ}00' - 10^{\circ}00' \\ &= 280^{\circ}00' \end{aligned}$$

$$\begin{aligned} \text{(ii) Line AC, true bearing} &= \text{magnetic bearing of AC} - \text{magnetic declination} \\ &= 340^{\circ}00' - 10^{\circ}00' \\ &= 330^{\circ}00' \end{aligned}$$

$$\begin{aligned} \text{(iii) Line AD, true bearing} &= \text{magnetic bearing of AD} - \text{magnetic declination} \\ &= 30^{\circ}00' - 10^{\circ}00' \\ &= 20^{\circ}00' \end{aligned}$$

3.11 DIP

A magnetic needle is an essential feature of all the compasses. It consists of a symmetrical and slender bar of magnetized cast steel supported at its centre of gravity, on a sharp and hard steel pivot. When suspended freely, it takes up a position parallel with the earth's magnetic lines. In horizontal projection these

lines define the magnetic meridian and thus the longitudinal axis of the magnetic needle lies in the plane of magnetic meridian and exhibits the direction magnetic north and south.

It is observed that in elevation, a magnetic needle in equilibrium is not in a horizontal plane, but in a plane inclined at a definite angle to the horizontal. This is because in elevation the lines of magnetic earth are inclined downward towards north in northern hemisphere and also downward towards south in southern hemisphere. At equilibrium the needle takes up a position parallel to these lines of forces and becomes inclined with the horizontal. This angle is known as *dip* or *inclination* of the needle.

The angle of dip varies from 0° at the equator to 90° at the magnetic poles, i.e. its value is not constant but varies from place to place. It is seldom necessary to measure the angle of dip in surveying, but for the needle to float in the horizontal plane, while observing the bearings, a small sliding sleeve weight or rider is attached to one end of the magnetic needle, e.g. on the south end in the northern hemisphere. By sliding this centre weight along the needle, the balance may be achieved.

Lines joining the loci of the places having the same value of dip are known as *isoclinic* lines, whereas those joining the loci of places with no dip are called *acclinic* lines such as the magnetic equator.

3.12 LOCAL ATTRACTION

The magnetic needle does not point to the magnetic north, when it is under the influence of the external attractive forces. In the presence of magnetic materials, such as iron pipes, steel structures, iron lamps, posts, rails, cables, chain, arrows, minerals deposits in the ground, etc., the needle is deflected from its normal position. Hence, local attraction by the magnetic materials is the disturbing influence on the magnetic needle of the compass. The amount of deviation of the magnetic needle is the measure of local attraction.

3.12.1 Detection of Local Attraction

The local attraction at any station is detected by observing the fore and back bearings of the line. If the difference between them is 180° , both the end stations are considered to be free from local attraction, provided the compass is devoid of any instrumental errors. If not, the discrepancy may be due to:

1. an error in observation of either fore or back bearing, or both.
2. presence of local attraction at either or both of the stations.

3.12.2 Elimination of Local Attraction

There are two methods by which local attraction can be eliminated.

By calculating the local attraction at each station Local attraction at each station is calculated and then the required corrections are applied to the observed bearings. It is most suitable for an open traverse. For a closed traverse,

the method fails when sum of the calculated included angles of the traverse is not equal to their theoretical sum. The steps involved are:

1. Observe a line whose fore and back bearings differ exactly by 180° .
2. The end stations of such a line are accepted which is free from local attraction and the bearings observed at such stations are taken to be correct. All the bearings observed on these stations are assumed to be free from local attraction.
3. The back bearings of the preceding line or the fore bearing of the next line will also be correct, since these are observed at the stations free from local attraction. The correct fore bearing of the preceding line or back bearing of the next line may be calculated by adding or subtracting 180° as the case may be and thus the correct bearing is obtained.
4. If the observed bearing is more than that of the correct bearing, the error at the station will be positive and therefore the correction will be negative, and vice versa.
5. The bearings of the lines are thus corrected one by one in succession.

By included angles This method is most suitable for a closed traverse. It may be noted that the local attraction affects all the magnetic bearings observed at that station by a fixed amount and in the same direction. Therefore, the included angles deduced even from the bearings affected by local attraction will be the true included angles at the affected stations. To correct the affected bearings, the following process is carried out.

1. Calculate the interior angles of the traverse and check their sum against $(2n \pm 4)$ right angles. If there is any error in the observed bearings other than local attraction, the theoretical sum of included angles will not tally with the sum of the calculated included angles.
2. Distribute the error, if any, equally to all the angles.
3. Locate the line, whose fore and back bearings differ by 180° .
4. Find out the correct bearing of the successive lines by using the correct observed bearing and the corrected included angles as explained in Sec. 3.9.

Note It may happen that in a closed traverse no line has a difference of 180° in its fore and back bearings. In such a case, the line with the least discrepancy is selected. Then the fore and back bearings of this line are adjusted so as to make the difference exactly 180° . Now assuming the fore bearing of this line to be correct, the correct fore bearings of all other lines are calculated as explained before.

Example 3.11 The bearings observed in traversing with a compass at a place where local attraction was suspected are given below:

Line	Fore Bearing	Back Bearing
AB	S45°30'E	N45°30'W
BC	S60°00'E	N60°40'W
CD	N03°20'E	S05°30'W
DA	S85°00'W	N83°30'E

At what stations do you suspect local attraction? Find the corrected bearings of the lines.

Solution The numerical value of the fore and back bearings of the line AB is the same. Hence stations A and B are free from local attraction and therefore F.B. of BC observed at station B is accepted to be correct.

Convert the quadrantal bearings to W.C.B.

AB	134°30'	314°30'	
BC	120°00'	299°20'	
CD	03°20'	185°30'	
DA	265°00'	83°30'	
F.B. of BC		120°00'	(correct)
Add 180°		+ 180°00'	
Correct B.B.	=	300°00'	
Observed B.B.	=	299°20'	
Error at C	=	- 40'	
Correction at C	=	+ 40'	
Observed F.B. of C		3°20'	
Correction		+ 40'	
Correct F.B. of CD		4°00'	
Add 180°		180°00'	
Correct B.B. of CD	=	184°00'	
Observed B.B. of CD		185°30'	
Error at D		1°30'	
Correction at D	=	- 1°30'	
Observed F.B. of DA		265°00'	
Correction at D		- 1°30'	
Correct F.B. of DA	=	263°30'	
Subtract 180°		83°30'	
Correct B.B. of DA	=		
Observed B.B. of DA	=		

Bearings corrected for local attraction are:

Line	F.B.	B.B.	Line	F.B.	B.B.
AB	134°30'	314°30'	AB	S45°30'E	N45°30'W
BC	120°00'	300°00'	BC	S60°00'E	N60°00'W
CD	4°00'	184°00'	CD	N4°00'E	
DA	263°30'	83°30'	DA	S83°30'W	

Example 3.12 The following bearings were taken in running a closed compass traverse while surveying in Jhunsi, Allahabad:

Line	F.B.	B.B.
AB	48°25'	230°00'
BC	177°45'	356°00'
CD	104°15'	284°55'
DE	165°15'	345°15'
EA	259°30'	79°00'

- State the stations which are affected by local attraction and by how much.
- Determine the correct bearings.
- Calculate the true bearings, if the declination was 1°30'W.

Solution Since F.B. and B.B. of line DE differ by 180°, the stations D and E are free from local attraction. Hence, fore bearing of EA is assumed to be correct.

F.B. of EA		259°30'	(correct)
Subtract 180°		- 180°00'	
Correct B.B. of EA		79°30'	
Observed B.B. of EA		79°00'	
Error at A		- 30'	
Correction at A	=	+ 30'	
Observed F.B. of AB		48°25'	
Correction		+ 30'	
Corrected F.B. of AB		48°55'	
Add 180°		180°00'	
Correct B.B. of AB		228°55'	
Observed B.B. of AB		230°00'	
Error at B		1°05'	
Correction at B	=	- 1°05'	
Observed F.B. of BC		177°45'	
Corrected F.B. of BC	=	176°40'	
Add 180°		180°00'	
Correct B.B. of BC	=	356°40'	
Observed B.B. of BC		356°00'	
Error at C		- 40'	
Correction at C	=	+ 40'	
Observed F.B. of CD		104°15'	
Corrected F.B. of CD	=	104°55'	
Add 180°		+ 180°00'	
Correct B.B. of CD	=	284°55'	
Observed B.B. to CD	=	284°55'	(checked)

The stations affected by local attraction are A, B and C, and by - 30', + 1°5' and - 40', respectively.

Bearings corrected for local attraction are:

Line	F.B.	B.B.
AB	48°55'	228°55'
BC	176°40'	356°40'
CD	104°55'	284°55'
DE	165°15'	345°15'
EA	259°30'	79°30'

As the magnetic declination is 1°30'W, subtract this from the fore and back bearings to get the true bearings.

Line	F.B. – declination = corrected F.B.	B.B. – declination = corrected B.B.
AB	48°55' – 1°30' = 47°25'	228°55' – 1°30' = 227°25'
BC	176°40' – 1°30' = 175°10'	356°40' – 1°30' = 355°10'
CD	104°55' – 1°30' = 103°25'	284°55' – 1°30' = 283°25'
DE	165°15' – 1°30' = 163°45'	345°15' – 1°30' = 343°45'
EA	259°30' – 1°30' = 258°00'	79°30' – 1°30' = 78°00'

Example 3.13 Given below are the bearings observed in a traverse survey conducted with a prismatic compass at a place where local attraction was suspected:

Line	Fore Bearing	Back Bearing
AB	124°30'	304°30'
BC	68°15'	246°00'
CD	310°30'	135°15'
DA	200°15'	17°45'

At what stations do you suspect local attraction? Find the correct bearings of the lines and the included angles.

Solution Refer to Fig. 3.16.

1st Method: By applying correction to the bearings

On inspection we find that the fore and back bearings of line AB differ exactly by 180°. Hence, A and B are free from local attraction. The bearings observed at stations A and B are accepted to be correct.

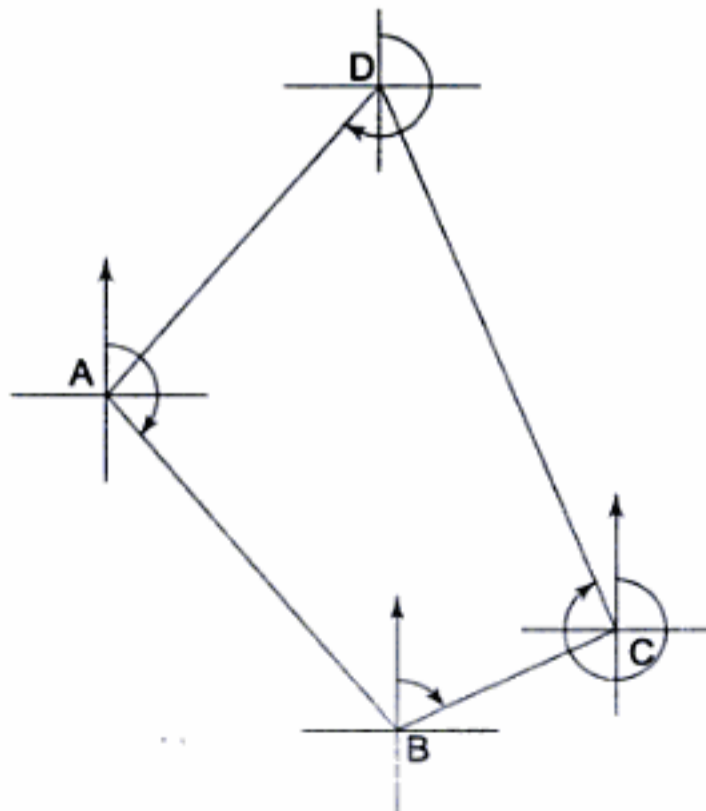

Fig. 3.16

Fore bearing of BC	=	68°15'	(correct)
Add		+ 180°00'	
Correct back bearing of BC		248°15'	
Observed back bearing of BC		246°00'	
Error at C		- 2°15'	
Correction		+ 2°15'	
Fore bearing of CD	=	310°30'	
Correction	=	+ 2°15'	
Corrected F.B. of CD	=	312°45'	
Subtract		- 180°00'	
Correct back bearing of CD	=	132°45'	
Observed back bearing of CD	=	135°15'	
Error at D	=	+ 2°30'	
Correction at D	=	- 2°30'	
Fore bearing of DA		200°15'	
Correction		- 2°30'	
Corrected fore bearing of DA	=	197°45'	
Subtract		- 180°00'	
Correct back bearing of DA		17°45'	
Observed back bearing of DA		17°45'	(checked)

Bearings corrected for local attraction are:

Line	F.B.	B.B.
AB	124°30'	304°30'
BC	68°15'	248°15'
CD	312°45'	132°45'
DA	197°45'	17°45'

IInd Method: By included angles

As the traverse is running anticlockwise, the included angles will be the interior angles.

$$\begin{aligned}
 \text{Angle at A} &= \text{F.B. of AB} - \text{B.B. of DA} \\
 &= 124^\circ 30' - 17^\circ 45' \\
 &= 106^\circ 45'
 \end{aligned}$$

$$\begin{aligned}
 \text{Angle at B} &= \text{F.B. of BC} - \text{B.B. of AB} \\
 &= 68^\circ 15' - 304^\circ 30' \\
 &= -236^\circ 15' \\
 &= 360^\circ - 236^\circ 15' \\
 &= 123^\circ 45'
 \end{aligned}$$

$$\begin{aligned} \text{Angle at C} &= \text{F.B. of CD} - \text{B.B. of BC} \\ &= 310^{\circ}30' - 246^{\circ}00' \\ &= 64^{\circ}30' \end{aligned}$$

$$\begin{aligned} \text{Angle at D} &= \text{F.B. of DA} - \text{B.B. of CD} \\ &= 200^{\circ}15' - 135^{\circ}15' \\ &= 65^{\circ}00' \end{aligned}$$

Check: Theoretical sum of interior angles = $(2n - 4) \times 90^{\circ} = 360^{\circ}$

$$\begin{aligned} \text{Sum of observed angles} &= \angle A + \angle B + \angle C + \angle D \\ &= 106^{\circ}45' + 123^{\circ}45' + 64^{\circ}30' + 65^{\circ}00' \\ &= 360^{\circ} \end{aligned}$$

Calculation of Bearings

Bearing of the line AB	=	124°30'	(correct)
Add included angle at B		+ 123°45'	
Sum	=	248°15'	
Sum is more than 180°, subtract 180°		- 180°00'	
Bearing of the line BC		68°15'	
Add included angle at C		+ 64°30'	
Sum	=	132°45'	
Sum is less than 180°, add 180°		+ 180°00'	
Bearing of the line CD	=	312°45'	
Add included angle at D		+ 65°00'	
Sum	=	377°45'	
Sum is more than 180°, subtract 180°		- 180°00'	
Add included angle at A		+ 106°45'	
Sum	=	304°30'	
Sum is more than 180°, subtract 180°		- 180°00'	
Bearing of the line AB	=	124°30'	

Line	Corrected fore bearing	Included angle	Angle value
AB	124°30'	A	106°45'
BC	68°15'	B	123°45'
CD	312°45'	C	64°30'
DA	197°45'	D	65°00'

Example 3.14 The following bearings were taken while conducting a close traverse with a compass in a place where local attraction was suspected:

Line	F.B.	B.B.
AB	80°45'	260°00'
BC	130°30'	311°35'
CD	240°15'	60°15'
DA	290°30'	110°10'

At what stations do you suspect local attraction? Find the corrected bearings for local attraction and for declination of 1°30'W.

Solution Refer to Fig. 3.17. On examining the fore and back bearings of the lines, it is found that the fore and back bearings of the line CD differ exactly by 180° . Hence, stations C and D are free from local attraction. Stations affected by local attraction are A and B. Since the traversing has been done in clockwise direction, the included angles are the exterior angles.

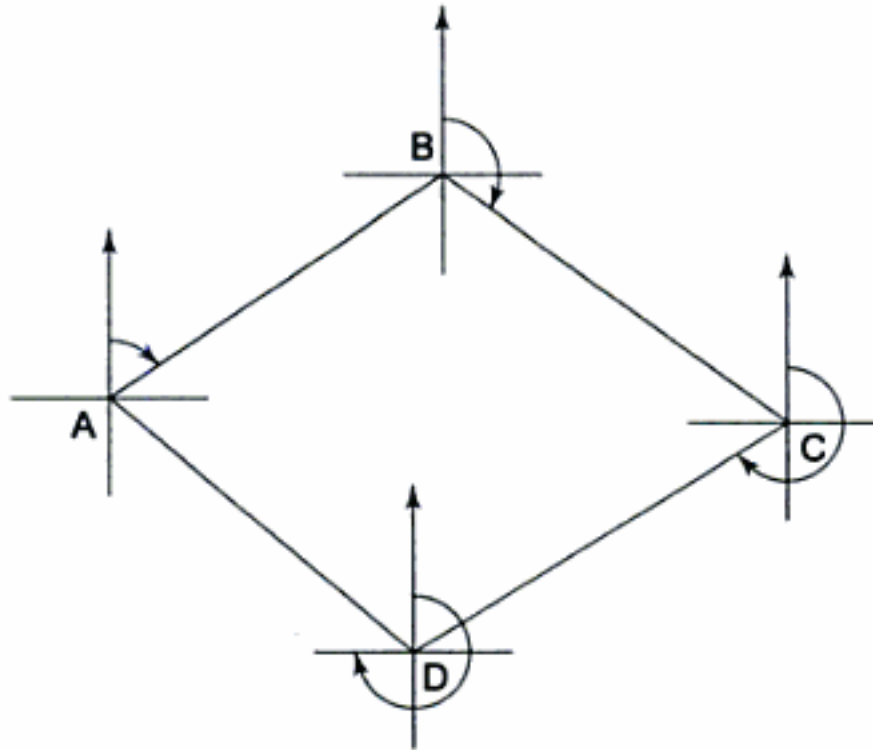

Fig. 3.17

1st Method: By included angles

$$\begin{aligned} \text{Angle at A} &= \text{F.B. of AB} - \text{B.B. of DA} \\ &= 80^\circ 45' - 110^\circ 10' + 360^\circ \\ &= 330^\circ 35' \end{aligned}$$

$$\begin{aligned} \text{Angle at B} &= \text{F.B. of BC} - \text{B.B. of AB} \\ &= 130^\circ 30' - 260^\circ 00' + 360^\circ \\ &= 230^\circ 30' \end{aligned}$$

$$\begin{aligned} \text{Angle at C} &= \text{F.B. of CD} - \text{B.B. of BC} \\ &= 240^\circ 15' - 311^\circ 35' + 360^\circ \\ &= 288^\circ 40' \end{aligned}$$

$$\begin{aligned} \text{Angle at D} &= \text{F.B. of DA} - \text{B.B. of CD} \\ &= 290^\circ 30' - 60^\circ 15' \\ &= 230^\circ 15' \end{aligned}$$

$$\begin{aligned} \text{Check: Theoretical sum of exterior angles} &= (2n + 4) \times 90^\circ \\ &= (2 \times 4 + 4) \times 90^\circ \\ &= 1080^\circ \end{aligned}$$

$$\begin{aligned} \text{Sum of observed angles} &= 330^\circ 35' + 230^\circ 30' + 288^\circ 40' + 230^\circ 15' \\ &= 1080^\circ 00' \end{aligned}$$

Calculation of bearings

Bearing of line CD	=	240°15'
Add included angle D	=	230°15'
Sum	=	470°30'
As sum is more than 180°, subtract 180°		- 180°00'
Bearing of line AD	=	290°30'
Add included angle A	=	330°35'
Sum	=	621°05'
As sum is more than 540°, subtract 540°		- 540°00'
Bearing of line AB	=	81°05'
Add angle at B		+ 230°30'
Sum		311°35'
As sum is more than 180°, subtract 180°		- 180°00'
Bearing of line BC	=	131°35'
Add angle at C		+ 288°40'
Sum		420°15'
As sum is more than 180°, subtract 180°		- 180°00'
Bearing of line CD	=	240°15'

Bearings corrected for local attraction are:

Line	F.B.
AB	81°05'
BC	131°35'
CD	240°15'
DA	290°30'

Correction for declination

As the declination is 1°30'W

The corrected true bearings are:

Line	F.B.	Declination	Corrected Bearings
AB	81°05'	1°30'W	81°05' - 1°30' = 79°35'
BC	131°35'	1°30'W	131°35' - 1°30' = 130°05'
CD	240°15'	1°30'W	240°15' - 1°30' = 238°45'
DA	290°30'	1°30'W	290°30' - 1°30' = 289°00'

Ind Method: By applying corrections to the bearings

Since fore and back bearings of line CD differ exactly by 180°, bearings of the line CD are accepted to be correct. Hence, C and D are free from local attraction. Therefore, the F.B. of DA observed at station D will also be correct.

Fore bearing of DA	=	290°30' (correct)
Subtract 180°		- 180°00'
Back bearing of DA	=	110°30'
Observed bearing of DA	=	110°10'
Error at A		- 20'

Correction at A	=	+ 20'
Observed fore bearing of line AB	=	80°45'
Correction		+ 20'
Corrected fore bearing of line AB		81°05'
Add 180°		180°00'
Correct back bearing of line AB	=	261°05'
Observed back bearing of line AB		260°00'
Error at B		- 1°05'
Correction at B	=	+ 1°05'
Observed fore bearing of BC	=	130°30'
Correction		+ 1°05'
Corrected fore bearing of BC	=	131°35'
Add 180°		+ 180°
Correct back bearing of BC		311°35'
Observed back bearing of BC		311°35' (checked)

The bearings corrected for local attraction are:

Line	Fore Bearing	Back Bearing
AB	81°05'	261°05'
BC	131°35'	311°35'
CD	240°15'	60°15'
DA	290°30'	110°30'

Now, the bearings can be corrected for declination in the same way as in the first method.

Example 3.15 Give the corrected bearings of the following traverse taken from a compass survey.

Line	Fore Bearing	Back Bearing
AB	191°30'	13°00'
BC	69°30'	246°30'
CD	32°15'	210°30'
DE	262°45'	80°45'
EA	230°15'	53°00'

Solution Refer to Fig. 3.18. On examining the values of the observed bearings of the lines, it will be noticed that no line in the traverse has a difference of 180° in its fore and back bearings. The included angles are first calculated.

As the traverse is running anticlockwise, the included angles will be the interior angles.

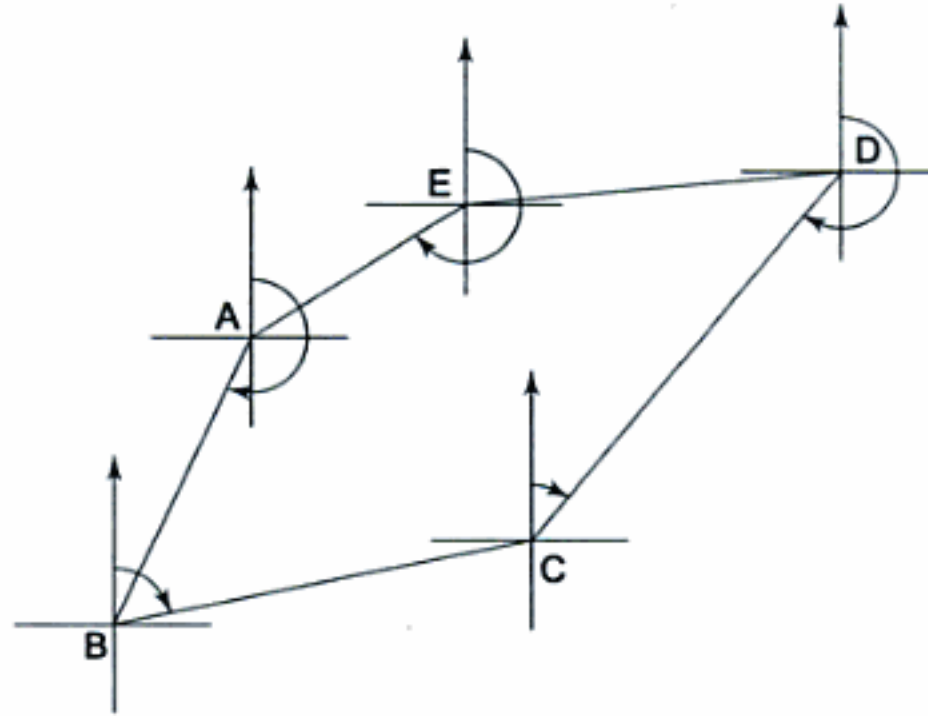

Fig. 3.18

$$\begin{aligned}\angle A &= \text{F.B. of AB} - \text{B.B. of EA} \\ &= 191^{\circ}30' - 53^{\circ}00' = 130^{\circ}30'\end{aligned}$$

$$\begin{aligned}\angle B &= \text{F.B. of BC} - \text{B.B. of AB} \\ &= 69^{\circ}30' - 13^{\circ}00' \\ &= 56^{\circ}30'\end{aligned}$$

$$\begin{aligned}\angle C &= \text{F.B. of CD} - \text{B.B. of BC} \\ &= 32^{\circ}15' - 246^{\circ}30' \\ &= -214^{\circ}15' \text{ (exterior angle)} \\ &= 360^{\circ} - 214^{\circ}15' = 145^{\circ}45'\end{aligned}$$

$$\begin{aligned}\angle D &= \text{F.B. of DE} - \text{B.B. of CD} \\ &= 262^{\circ}45' - 210^{\circ}30' \\ &= 52^{\circ}15'\end{aligned}$$

$$\begin{aligned}\angle E &= \text{F.B. of EA} - \text{B.B. of DE} \\ &= 230^{\circ}15' - 80^{\circ}45' \\ &= 149^{\circ}30'\end{aligned}$$

Check: Theoretical sum of the angles = $(2n - 4) \times 90^{\circ} = 540^{\circ}$ ($n = 5$)

Sum of the observed angles

$$\begin{aligned}&= 138^{\circ}30' + 56^{\circ}30' + 145^{\circ}45' + 52^{\circ}15' \\ &\quad + 149^{\circ}30' \\ &= 542^{\circ}30'\end{aligned}$$

The error in included angles = $542^{\circ}30' - 540^{\circ}$

$$= +2^{\circ}30'$$

$$\text{Correction} = -2^{\circ}30'$$

This correction is distributed equally in all the angles

$$\text{Corrected angles } \angle A = 138^{\circ}38' - 30' = 138^{\circ}00'$$

$$\angle B = 56^{\circ}30' - 30' = 56^{\circ}00'$$

$$\angle C = 145^{\circ}45' - 30' = 145^{\circ}15'$$

$$\angle D = 52^{\circ}15' - 30' = 51^{\circ}45'$$

$$\angle E = 149^{\circ}30' - 30' = 149^{\circ}00'$$

Computation of correct bearings As all the stations are affected by local attraction, the line having the least deviation from 180° in its fore and back bearings is chosen, and to correct it, the error is distributed equally in its fore and back bearing.

Line	F.B.	B.B.	Difference	Deviation	Correction	Correct F.B.
AB	$191^{\circ}30'$	$13^{\circ}00'$	$178^{\circ}30'$	$1^{\circ}30'$	$1^{\circ}30'/2$	$192^{\circ}15'$
BC	$69^{\circ}30'$	$246^{\circ}30'$	$177^{\circ}00'$	$3^{\circ}00'$	$= 45'$	
CD	$32^{\circ}15'$	$210^{\circ}30'$	$178^{\circ}15'$	$1^{\circ}45'$		
DE	$262^{\circ}45'$	$80^{\circ}45'$	$182^{\circ}00'$	$2^{\circ}00'$		
EA	$230^{\circ}15'$	$53^{\circ}00'$	$177^{\circ}15'$	$2^{\circ}45'$		
Corrected F.B. of AB					=	$192^{\circ}15'$
Add $\angle B$						$+ 56^{\circ}00'$
Sum					=	$248^{\circ}15'$
As sum is more than 180° , subtract 180°						$- 180^{\circ}00'$
Corrected F.B. of BC					=	$68^{\circ}15'$
Add $\angle C$						$+ 145^{\circ}15'$
Sum					=	$213^{\circ}30'$
As sum is more than 180° , subtract 180°						$- 180^{\circ}00'$
Corrected F.B. of CD					=	$33^{\circ}30'$
Add $\angle D$						$+ 51^{\circ}45'$
Sum					=	$85^{\circ}15'$
As sum is less than 180° add 180°						$+ 180^{\circ}00'$
Corrected F.B. of DE					=	$265^{\circ}15'$
Add $\angle E$					=	$149^{\circ}00'$
Sum					=	$414^{\circ}15'$
As sum is more than 180° , subtract 180°						$- 180^{\circ}00'$
Corrected F.B. of EA					=	$234^{\circ}15'$
Add $\angle A$						$+ 138^{\circ}00'$
Sum					=	$372^{\circ}15'$
As sum is more than 180° , subtract 180°						$- 180^{\circ}00'$
Corrected F.B. of AB					=	$192^{\circ}15'$ (checked)

Corrected fore bearings are:

Line	F.B.
AB	$192^{\circ}15'$
BC	$68^{\circ}15'$
CD	$33^{\circ}30'$
DE	$265^{\circ}15'$
EA	$234^{\circ}15'$

3.13 DETERMINING TRUE MERIDIAN

The true meridian is used as a reference in any extensive survey. This is because a true meridian does not change with time and because the relationship of true meridian established at different points is always known regardless of the distance between the points.

Observation of any celestial body like the sun, north star, Polaris, etc. whose astronomical position is known, makes possible the establishment of a true meridian passing through the point occupied at the time of observation.

The procedure consists in measuring the vertical angles between the sun and a horizontal plane and the horizontal angle between a line AB and the sun (Fig. 3.19). The time of observation is noted. With the latitude of the instrument position (point A) known, the angle between the true meridian (N – S) and the sun can be computed for any given time. Since the horizontal angle B – A – sun has been measured, the angle B – A – N can be computed. The best time to obtain most accurate results is mid morning or mid afternoon.

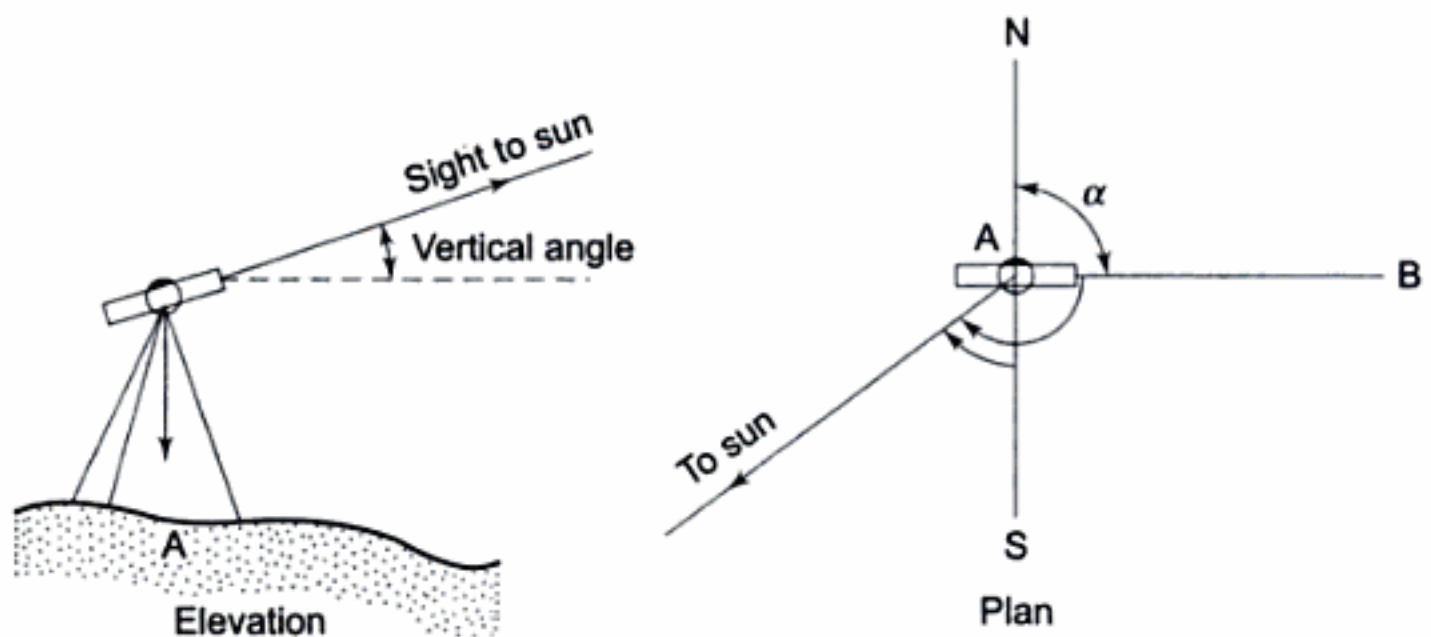

Fig. 3.19

3.14 CHAIN SURVEYING VERSUS COMPASS SURVEYING

Table 3.2 gives the comparison between chain surveying and compass surveying.

Table 3.2 Comparison of chain surveying and compass surveying

S.No.	Chain surveying	Compass surveying
1.	Chain is mainly used for linear measurements.	Compass is mainly used for angular measurements.
2.	The framework consists of triangles, the sides of which are measured by chain. No angular measurements are done.	The Framework consists of a series of connected lines. The lengths of the lines are measured by chain and the angles by compass.

(Contd.)