

---

This is a reproduction of a library book that was digitized by Google as part of an ongoing effort to preserve the information in books and make it universally accessible.

Google™ books

<https://books.google.com>





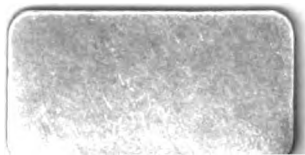





**NESBIT'S**  
**PRACTICAL LAND-SURVEYING.**

**PRINTED BY BALLANTYNE AND COMPANY  
EDINBURGH AND LONDON**

**NESBIT'S**  
**PRACTICAL LAND-SURVEYING.**

**EDITED BY**  
**WILLIAM BURNESSE, F. R. A. S.**  
**PROFESSOR OF PRACTICAL LAND-SURVEYING.**

**Twelfth Edition.**



**LONDON:**  
**LONGMANS, GREEN, READER, AND DYER.**  
1870.

*183. e. 26.*





# ADVERTISEMENT

TO

THE TWELFTH EDITION.

---

THE demand which has carried this now standard work through eleven editions is a sufficient index of the high esteem in which it is held, and renders it unnecessary for the Publishers to do more than announce the Twelfth Edition of NESBIT'S PRACTICAL LAND-SURVEYING. The Appendix has been re-written, and in it is included the General Inclosure Act of 1845, which contains the statutory provisions for the extension, improvement, division, &c., of commons and waste lands, and the required formulæ for the surveyor and valuer. To this Act, which is given in full, is appended a list of the Acts, passed subsequently, relative to inclosures.



## ADVERTISEMENT

TO

THE ELEVENTH EDITION.

---

THE thorough revision and enlargement of NESBIT'S PRACTICAL LAND-SURVEYING cannot fail to continue for it the very prominent position which it has long held as a standard work. The sale of TEN LARGE EDITIONS, and the demand for the present one, is a very gratifying testimony of the patronage it has hitherto merited of land-surveyors, civil engineers, masters of seminaries, and the general public.

The subdivision of the work into Ten Parts, as in the last edition, has been continued. The *First Part* is elementary, and contains definitions, with a few select problems and theorems. The *Second* gives a description of the chain, offset-staff, compass, &c., with directions for their use. The *Third* and *Fourth* embrace the mensuration of single fields, the former with the common cross-staff and chain, the latter with the chain only. Part IV. also teaches how to survey hilly and uneven ground. The surface of the earth consists of a series of hypotenusal planes joined by curved lines, and before the dimensions of these can be plotted on to a plan, they have to be reduced to base-measure or that of a common plane; and this part gives various methods of doing so by the chain, quadrant-level, and theodolite. The *Fifth*, *Sixth*, and *Seventh* teach how to survey large estates, apportion land, plot, finish, transfer and reduce plans. Part VI. belongs to the higher branch of land-surveying, and is divided into *four sections*, the *first* of which is elementary, the *second* practical; the *third* gives general directions for field operations, and the *fourth* the reduction of customary to statute measure. Part VII. includes the surveying of farm-buildings, cities, towns, villages, and lands for building purposes. The *Eighth* and *Ninth* teach the elements of trigonometry, and their application by examples. *Railway*

*Surveying* follows, and includes illustrated general directions for taking a preliminary survey of a projected railway. The *Tenth* includes *Railway Engineering* under seven sections, viz. :—

Section I. treats of levels and levelling, including trial, check, and cross levels; check levelling; correction for curvature and refraction.

Section II. contains a Parliamentary survey, with plan and section; the method of keeping the level-book and of plotting the sections; also the method of laying out gradients, &c.

Section III. shows the general principles and practice of laying out railway curves, including compound, serpentine, and deviation examples, with the necessary constructions and formulas required.

Section IV. embraces railway earthworks, and gives formulas for setting out the width of the ground, for finding the areas of the railway estate, together with auxiliary tables for finding the contents of sectional areas.

Section V. gives the methods of setting out the ground for tunnels and tunnelling, including tables of dimensions.

Section VI. is on viaducts, aqueducts, oblique railway bridges, and includes examples with dimensions.

Section VII. comprises the survey and applications of rules for the superelevation of the outside rails at railway curves.

The following is a brief summary of the principal additions and alterations made to the present edition.

Part II.—Two new articles have been written for this Part: the one on *the variation of the needle of the compass*; and the other, directions for correcting the compass so as to *find out the true meridian*.

Parts III and IV.—In these two Parts one proposition (page 85) has been corrected, and two new ones, with a diagram, added, in order to supply the necessary instruction required in ranging and measuring lines in surveys with the chain when sight is obstructed. The methods of measuring *hilly ground* have been re-written; so have the articles under a Quadrant, a brief description of several additional instruments of this kind being given. *General directions* for surveys on the vertical plane have likewise been added in Part III.

Parts V. and VI.—Very many corrections have been made in these two divisions, paragraphs out of date suppressed, and new ones written to supply their places. General directions for eight additional surveys have been added to the latter (Part VI.), while the

statutory matter which it contained in previous editions has been transferred to the end of the work in the form of an Appendix. The two first surveys are on the horizontal plane, and embrace *lands intersected by a railway*. The remaining six include surveys of rivers, tidal, mountainous, and intermediate; canals, embankments, lands reclaimed from the sea, &c. They are principally on the vertical plane, and form together a large section, viz., Section III.

Part VII.—General directions for surveying and designing man- sions, farm homesteads, stackyards, &c., have been added to this Part; other portions of it have been re-written.

Part VIII. has been divided into *five Sections*. Sect. I. consists of definitions and corollaries. Sect. II. treats of the species, construc- tions, ratios, resolution and solution, of triangles. Sect. III. gives the trigonometrical solution of plane triangles, right-angled, and oblique. Sect. IV. the measurement of angles, with an illustrated description of the theodolite. Sect. V. is on the trigonometrical survey of *heights and distances*. The first two sections have been added to this edition of the work. They have been written ex- pressly to illustrate, by means of the several diagrams annexed, the elementary principles and practice of trigonometrical surveying: it is hoped they will prove not only instrumental in facilitating the education of private students, but also in promoting that of articed pupils in field operations with the theodolite, and in the office work of plotting the bearings. Three of the cases in Sect. III. have been re-written, and numerous corrections made in this and the remaining two sections of this Part.

Part IX. embraces examples of trigonometrical surveying; it has been divided into *seven Sections*. Sect. I. contains rules for finding the areas of triangles by logarithms. Sect. II. To survey a wood. Sect. III. To survey a wood or river. Sect. IV. gives the practice of taking bearings by two stations. Sect. V. To survey a town or city. Sect. VI. To range lines and take bearings in extensive surveys. Sect. VII. To survey with the circumferentor. Of these, Sect. VI. has been written for the present edition, and also the Introduction containing the new subdivision of this Part.

The section under Railway Surveying has been re-written in the form of illustrated general directions for taking a preliminary survey of a portion of a projected railway. In the previous edition the illustration or plan (p. 387), and the subject-matter of the sec- tion generally, was in Part IX. under a different heading; but as

the field notes for the plan were wanting, and as the subject-matter was otherwise very defective, and as the former omission could not be supplied, or the latter defects corrected, without an actual survey of the ground,—conditions almost wholly impracticable,—it was considered advisable to make this change, as preliminary surveys of the kind in question are frequently demanded for reasons that will be found in the section to which we refer.

In this branch of land-surveying it is a standing rule that the measure of every line and angle shall be determined both by linear and angular instruments; and when an error or an omission is detected in any of the field books open, the error must be corrected, and the omission supplied in the field. The reason of this is, because the exceptions are few where a single line in a survey can be accurately measured with the chain; consequently, if a continuous check is not kept upon linear measure by angular, the field notes, both for plotting and setting out curve lines and inclinations or gradients, cannot be obtained with that degree of accuracy which the nature of the survey demands. If the station poles are accurately ranged, then the lines in the field close; and in plotting either plan or section, the only proof of accuracy admissible is when the lines formed by the station-points also close, for unless they do so, the subsequent operations of the survey cannot be correctly performed.

W. B.

# CONTENTS.



## PART I.

	PAGE
Geometrical Definitions . . . . .	1
Geometrical Problems . . . . .	7
<b>PROB.</b> 1. To bisect a given line . . . . .	7
2. To bisect a given angle . . . . .	8
3. To draw a line parallel to a given line . . . . .	8
4. To erect a perpendicular from a given point, near the middle of a given line . . . . .	8
5. To erect a perpendicular from a given point, near the end of a given line . . . . .	9
6. From a given point, to let fall a perpendicular upon a given line . . . . .	9
7. To construct a triangle of three given lines . . . . .	9
8. Having given the base and perpendicular, to construct a triangle . . . . .	10
9. To describe a square whose side shall be equal to a given right line . . . . .	10
10. To describe a rectangular parallelogram whose length and breadth shall be equal to two given lines . . . . .	10
11. Upon a given right line to construct a rhombus . . . . .	11
12. With two given right lines, as sides, to construct a rhomboid . . . . .	11
13. With a given base and two given perpendiculars, to construct a trapezoid . . . . .	12
14. With four given sides, to construct a quadrilateral figure which has one right angle . . . . .	12
15. With given transverse and conjugate diameters, to construct an ellipse . . . . .	12
16. To reduce a given trapezium to a triangle of equal area . . . . .	13
17. To reduce an irregular polygon of five sides to a triangle of equal area . . . . .	14
18. To raise a perpendicular by a scale of equal parts . . . . .	14
19. To make a right angle by the line of chords on the plane scale . . . . .	15
20. To make an acute angle . . . . .	15
21. To make an obtuse angle . . . . .	15
22. To find the number of degrees contained in a given angle . . . . .	16
23. To lay down a line making a given angle with the meridian line . . . . .	16
Geometrical Theorems . . . . .	17



## PART II.

	PAGE
The Chain . . . . .	21
The Cross-Staff . . . . .	22
The Offset-Staff . . . . .	22
The Compass . . . . .	23
Variation of the Needle . . . . .	24
To find a True Meridian . . . . .	24
The Field-Book . . . . .	24
Directions to young Surveyors when in the Field, &c. . . . .	25
Directions concerning Scales, Laying down Figures, &c. . . . .	27

## PART III.

To Survey with the Chain and Cross . . . . .	29
A Table of Lineal Measures . . . . .	30
A Table of Square Measures . . . . .	30
PROB. 1. Square fields . . . . .	30
2. Rectangular fields . . . . .	32
3. Triangular fields . . . . .	34
4. Fields in the form of a trapezium . . . . .	36
5. Fields comprehended under more than four straight sides . . . . .	40
6. Fields comprehended under any number of crooked sides . . . . .	49
7. Narrow pieces of land . . . . .	65
8. Meres and woods . . . . .	71
9. To find the area of segment of a circle, or any other curvilinear figure, by means of equidistant ordinates . . . . .	75
10. To find the breadth of a river . . . . .	83
11. Lines upon which there are impediments not obstructing the sight . . . . .	84
12. Lines upon which impediments obstruct the sight . . . . .	85

## PART IV.

To Survey with the Chain only . . . . .	86
Miscellaneous Instructions . . . . .	86
PROB. 1. Triangular fields . . . . .	87
2. Fields in the form of a trapezium . . . . .	97
3. Fields of more than four sides . . . . .	115
4. Meres and woods . . . . .	132
5. To measure and plan roads, rivers, canals, &c. . . . .	135
6. To take distances by the chain and scale . . . . .	138
7. To erect a perpendicular by the chain . . . . .	139
8. From the plan of a field, and its true area, to discover the scale by which it has been constructed . . . . .	139
To Measure Hilly Ground . . . . .	140
Methods used by Practical Surveyors to Reduce Hypotenusal to Horizontal Lines . . . . .	141
METHOD I. . . . .	141
A table for reducing hypotenusal to horizontal lines . . . . .	142

	PAGE
Quadrants and their use . . . . .	142
To take the altitude of a hill with the quadrant . . . . .	143
To take the altitude of a steeple . . . . .	143
<b>METHOD II.</b> . . . . .	143
To preserve the horizontal line by elevating the chain, in ascending or descending a hill . . . . .	143
<b>METHOD III.</b> . . . . .	145
The description and use of King's quadrant . . . . .	145
Nesbit's quadrant . . . . .	147
A table by which a quadrant (invented by the author) may be constructed, answering the same purpose as King's . . . . .	148
The construction of the above table . . . . .	148
The construction of Nesbit's quadrant . . . . .	149
The method of proving it . . . . .	151
The method of applying it in surveying . . . . .	151
Methods of finding the hypotenusal measure of hilly ground . . . . .	152
General directions for the vertical survey of a hill . . . . .	156

## PART V.

To Survey Farms, large Estates, or Lordships . . . . .	159
<b>METHOD I.</b> By triangles . . . . .	159
Plan of ditto . . . . .	160
<b>METHOD II.</b> By running lines nearly parallel to each other . . . . .	162
Plan of ditto . . . . .	163
<b>METHOD III.</b> By tie-lines, &c. . . . .	164
<b>METHOD IV.</b> By running lines in the most advantageous manner, without regarding any particular method . . . . .	164
Miscellaneous Instructions relating to running lines, putting down Stations, ranging the Poles, measuring across Valleys, observing the Fences, &c. &c. . . . .	165
General Rules for planning large Surveys . . . . .	168
Directions for planning the Estate in Plate VIII. . . . .	169
Directions for planning the Estate in Plate X. . . . .	170
Drawing Paper, Pencils, &c. . . . .	171
To compute the Contents of Estates . . . . .	172
The Use of the Parallel Ruler, in reducing crooked fences to straight ones, in order to find the areas of fields by the method of casting . . . . .	173
<b>PROB. 1.</b> To draw a right line from a given point so as to divide the field equally . . . . .	173
2. To draw a right line from a given point so as to reduce an irregular field to a right-angled triangular one . . . . .	174
3. To reduce an irregular field to a right-angled triangle, by drawing the equalising line through the offset fences . . . . .	174
4. To lay down a right-line offset from given dimensions, &c. . . . .	175
5. To lay down a curve-line offset from given dimensions, &c. . . . .	176
6. To reduce a curve-line offset area to a right-angled triangle . . . . .	178
7. To reduce an irregular right-line offset figure to a triangle . . . . .	179

	PAGE
PROB. 8. To reduce a right-line offset field of twelve sides to a triangle	180
9. To reduce a right-line offset field of eleven sides to a trapezium	181
10. To reduce a curve-line and right-line offset field to a trapezium	182
11. To divide by an equalising line a crooked eight-line offset fence between two fields on the principle of " <i>take and give</i> "	183
12. To divide by an equalising line a crooked curve-line offset fence between two fields, on the principle of " <i>take and give</i> "	184
A General Rule for using the Parallel Ruler	185
A Book of Dimensions, Castings, and Areas, belonging to Plate VIII.	186
Ditto belonging to Plate X.	187
To Transfer a rough Plan to a clean sheet, in order to make a finished Plan	188
METHOD I. By points	188
METHOD II. By tracing-paper	188
METHOD III. By a copying-glass	188
METHOD IV. By similar squares	189
METHOD V. By the pentagraph	190
A description of the pentagraph	191
The method of using the pentagraph in copying and reducing plans	192
To embellish or finish plans	193
METHOD I.	194
To finish plans neatly with Indian ink and colours	194
How to choose Indian ink	195
Colours necessary for a Land-Surveyor	196
METHOD II.	196
To finish plans highly, with Indian ink and colours	196
To shade and colour meadows	196
Pasture-grounds	196
Corn-fields	196
Moors	198
Marshy ground	198
Sands, rocks, and loose stones	198
Trees	200
Lakes, rivers, and the sea-shore	201
Hilly ground	201
Pleasure-grounds	201
Gardens	202
The bases of buildings	202
The elevations of buildings	203
METHOD III.	205
To finish plans highly with Indian ink only	205
Shading with the pen	205
Penmanship	205
Ornaments	206
Ornaments on Plate IX.	206
Ditto on Plate XI.	206
Miscellaneous Instructions relating to Surveying, Planning, Casting, Valuing, &c. &c.	207
A Terrier of the Survey in Plate IX.	209

PART VI.

	PAGE
Directions for Apportioning land ; for Laying out, Parting off, and Dividing Land ; for Surveying Lands intersected by a Railway ; Rivers, &c. &c., with <i>six examples</i> ; and for reducing Statute Measure to Customary, and <i>vice versa</i> ; including Scotch and Irish Measures . . . . .	210

SECTION I.

Table for reducing acres, &c., to square links . . . . .	211
PROB. 1. To reduce acres, roods, and perches into square links . . . . .	211
2. To lay out, in a square, any quantity of land proposed . . . . .	212
3. Upon a given line, to make a rectangle which shall contain any proposed quantity of land . . . . .	213
4. To lay out any given quantity of land in a rectangle, so that one of its sides shall be two, three, four, or any number of times as long as the other . . . . .	214
5. Upon a given base, to lay out a triangle that shall contain any given number of acres, &c. . . . .	214
6. Upon a given side, or base-line, to lay out a trapezium which shall contain any number of acres . . . . .	215
7. Upon a given base, to lay out a rhombus of any content less than the square of the base . . . . .	217
8. To lay out any given quantity of land in a circle . . . . .	218
9. To lay out any given quantity of land in a regular polygon . . . . .	220
10. To lay out any given quantity of land in an ellipse, with a given diameter . . . . .	221
11. To part from a square or rectangle any proposed quantity of land, by a line parallel to one of its sides . . . . .	222
12. To part from a square or rectangle any proposed quantity of land, either in a right-angled triangle or a trapezoid, by a line drawn from any of the angles to either of the opposite sides . . . . .	224
13. To part from a triangle, upon the base or longest side, any proposed quantity of land, by a line drawn from either of the angles at the base, to the opposite side . . . . .	226
14. To part from a triangle any proposed quantity of land, by a line parallel to any of its sides . . . . .	227
15. To part from a rectangle or triangle any proposed quantity of land, upon a line on which there are offsets, when the area of those offsets is to be considered as part of the portion to be parted off . . . . .	228
16. To part from a trapezium, or any irregular polygon whatever, any proposed quantity of land, by a line drawn parallel to any of the sides, or by a line drawn from any of the angles, or from any assigned point in one of the sides, to any of the opposite sides . . . . .	231

SECTION II.

PROB. 1. To divide a square or rectangle, either equally or unequally, among any number of persons, by lines parallel to one of its sides . . . . .	238
2. To divide a triangular field, either equally or unequally, among any number of persons, by fences made from any of its angles to the opposite side . . . . .	240

	PAGE
PROB. 3. To divide a triangular field, either equally or unequally, among any number of persons, by fences proceeding from any assigned point in one of its sides . . . . .	242
4. To divide a triangular field, either equally or unequally, among any number of persons, by fences made parallel to one of its sides . . . . .	244
5. To divide a trapezium, or any irregular polygon, either equally or unequally, among any number of persons, by fences made in a given direction . . . . .	246
6. To divide a common or any quantity of land, of uniform value, among any number of proprietors, in the proportion of their respective interests . . . . .	249
7. To divide a common, &c., of variable value, among any number of proprietors, in the proportion of their respective interests . . . . .	251
Miscellaneous Observations on Valuing Land . . . . .	252
Appellations given to certain Lands . . . . .	253
Directions for setting out new Roads, Sand-pits, Quarries, Watering-places, &c. &c. ; and for dividing Commons and Waste Lands into Allotments . . . . .	255
To determine the Value of each Proprietor's Allotment, or Claim upon the Common . . . . .	256
To set off, upon the Plan, each Proprietor's Allotment or Share of the Common	257
An example of dividing the Common in Plate XII., &c. . . . .	257
A Book of Quantities, Qualities, Values, &c., belonging to Plate XII. . . . .	258
The operation of finding the Value of each Proprietor's Share of the Common, and Directions for setting out the Allotments in the Field . . . . .	259
The proof of the Division . . . . .	260
General Directions for apportioning Lands intersected by a Railway . . . . .	261
EXAMPLE 1. Intersected parks and farms . . . . .	261
2. Intersected estates, parishes, and counties . . . . .	264

## SECTION III.

Directions for Surveying Rivers, Canals, Embankments, &c., in Six Surveys . . . . .	267
EXAMPLE I. Directions for the survey of lands to be reclaimed from the sea . . . . .	267
Directions for ranging station poles . . . . .	268
Directions for the horizontal survey . . . . .	271
Directions for longitudinal and transverse sections for embankments . . . . .	273
II. Directions for the survey of a tidal river . . . . .	274
1. The breadth of a river as determined by its tributaries . . . . .	275
2. The breadth of a river as determined by tidal action . . . . .	275
3. The velocity of a river as determined by its tidal length . . . . .	277
4. New channel and embankments . . . . .	278
A new outfall . . . . .	278
Straightening a river . . . . .	279
5. Methods for counteracting tidal action . . . . .	280
6. Influx of tributary rivers . . . . .	280
III. General directions for horizontal survey of lands reclaimed under the first and second examples . . . . .	281
1. Quality of soil . . . . .	282
2. Drainage . . . . .	282
3. Embankments . . . . .	283

	PAGE
4. Roads, fences, and farm buildings . . . . .	284
5. Area outside embankments . . . . .	284
EXAMPLE IV. General directions for the survey of a river in a large valley from high-water level upwards . . . . .	285
1. Outfall levels of the river and its tributaries . . . . .	286
FIRST METHOD OF LOWERING OUTFALL . . . . .	286
SECOND METHOD . . . . .	286
THIRD METHOD . . . . .	287
FOURTH METHOD . . . . .	288
2. General fall of the river . . . . .	288
Tangential errors in levelling . . . . .	289
Errors due to refraction . . . . .	291
Hypotenusal errors . . . . .	291
Check-water levels . . . . .	292
Longitudinal section . . . . .	292
Surface level of the river . . . . .	294
Plotting the dimensions . . . . .	295
General rule for inclination of river . . . . .	297
3. Volume of water . . . . .	297
4. Area of land required for embankments . . . . .	298
5. Subdivision and apportioning land where the river is straightened . . . . .	299
6. Water power, irrigation works, bleaching grounds, &c. . . . .	299
7. Provision for the drainage of adjoining lands . . . . .	299
8. New roads, bridges, fences, drainage, and levelling of the old channel . . . . .	300
V. General directions for the survey of mountain rivers . . . . .	301
VI. General directions for the survey of canals, irrigation works, and warp-lands . . . . .	304
Canals . . . . .	304
Irrigation works . . . . .	309
Warp-lands . . . . .	310

SECTION IV.

The Method of reducing Local or Customary Measures to Statute Measure, and <i>vice versa</i> . . . . .	311
PROB. 1. To reduce customary measure to statute measure, and <i>vice versa</i> . . . . .	311
General rules . . . . .	311
2. To reduce Scotch and Irish measures to English statute measure, and <i>vice versa</i> . . . . .	313
To estimate commons, moors, lordships, counties, or kingdoms, by the square mile, &c. . . . .	315

PART VII.

SECTION I.

The Method of Measuring and Planning Villages, Towns, and Cities . . . . .	316
General Directions for taking the Dimensions of Villages, Towns, and Cities . . . . .	317

	PAGE
Directions for Surveying and Planning Mansions, Farm-buildings, Stack-yards, &c. . . . .	320
Directions for taking the Dimensions of the New Town in Plate VII. . . . .	321
Directions for Planning Villages, Towns, and Cities . . . . .	321
Drawing Pencils . . . . .	323
Plotting Scales . . . . .	323
Various Plans recommended . . . . .	323
To clean Plans or Maps . . . . .	323
Indian Rubber . . . . .	324
Pounce or Gum Sandarach . . . . .	324
Sponge . . . . .	324

## SECTION II.

Directions for Measuring and Planning Building-ground, and dividing it into convenient lots for sale . . . . .	325
Directions for taking the Dimensions . . . . .	325
Various Examples . . . . .	326
Directions for Planning, Dividing, Laying Out, &c. &c. . . . .	329
House-steads must be of various sizes, according to the respectability of the intended Buildings . . . . .	330
Different Pieces of Building-ground . . . . .	330

## SECTION III.

Miscellaneous Questions relating to Surveying, Laying out, Parting off, and Dividing Land . . . . .	331
---	-----

## PART VIII.

## PLANE TRIGONOMETRY.

## SECTION I.

Definitions . . . . .	334
Corollaries . . . . .	336

## SECTION II.

Species, construction, ratios, resolution, and solution of Triangles . . . . .	339
Right-angled Triangles . . . . .	340
Oblique-angled Triangles . . . . .	342

## SECTION III.

Solution of Right-angled Plane Triangles . . . . .	349
CASE I. . . . .	349
II. . . . .	350
III. . . . .	351
Solution of Oblique-angled Plane Triangles . . . . .	352
CASE I. . . . .	352
II. . . . .	352
III. . . . .	354
IV. . . . .	355

## SECTION IV.

The Measurement of Angles . . . . .	356
The Theodolite . . . . .	357

	PAGE
To take a Horizontal Angle with the Theodolite . . . . .	358
To take a Vertical Angle . . . . .	359
Adjustments of the Theodolite—	
I. To adjust the line of collimation . . . . .	359
II. To adjust the axis of the level with that of the telescope . . . . .	359
III. To make the axes of the levels on the vernier plate parallel to it . . . . .	359
The Vernier . . . . .	360
1. To find fractional parts of a degree by the vernier . . . . .	360
2. To set the theodolite to any angle . . . . .	360

SECTION V.

HEIGHTS AND DISTANCES.

PROB. 1. To measure a base line across a wide river . . . . .	360
2. To continue the direction and measurement of a given line when buildings or other obstructions stand in the way, which can be avoided by going to the right or left . . . . .	363
3. To find the distance of accessible objects, when obstructions prevent the measurement of these distances in direct lines . . . . .	364
4. To find the height of a tower, standing on a horizontal plane, the base of which is accessible . . . . .	364
5. To find the height when the base is inaccessible . . . . .	365
6. To find the height of a tower standing on the side or top of an inaccessible hill . . . . .	366

PART IX.

TRIGONOMETRICAL SURVEYING.

SECTION I.

RULES FOR FINDING AREAS.

Preliminary Problems . . . . .	367
PROB. 1. . . . .	367
2. . . . .	368
3. . . . .	368
4. . . . .	369

SECTION II.

To Survey a Wood by the Theodolite . . . . .	369
--	-----

SECTION III.

To Survey a Road or River . . . . .	371
-------------------------------------	-----

SECTION IV.

The Practice of Taking Bearings by Two Stations . . . . .	373
---	-----

SECTION V.

To Survey a Town or City . . . . .	375
------------------------------------	-----

SECTION VI.

To Range Lines and take Bearings in extensive Surveys . . . . .	377
---	-----



## SECTION VII.

	PAGE
The Circumferentor . . . . .	383
To Find the Bearings of an Object by the Circumferentor . . . . .	384
On Plotting the Bearings taken by the Circumferentor . . . . .	384

## RAILWAY SURVEYING . . . . . 385

Illustrated General Directions for a Preliminary Survey of a Projected Rail- way . . . . .	386
To range Lines . . . . .	386
Copy of a Plan of a Projected Railway . . . . .	387
To lay down the Base Lines, and draw the Projected Railway upon an Ordnance or other Map . . . . .	388
To range the Secondary and Minor Lines . . . . .	388
To take Bearings, and measure the first Base Line . . . . .	389
To take Bearings, and measure the second Base Line . . . . .	391
Details of the Survey . . . . .	391

## PART X.

## RAILWAY ENGINEERING.

## SECTION I.

## LEVELLING.

On Levelling in general . . . . .	392
Description of the Y Level . . . . .	392
Adjustments of the Level . . . . .	393
Troughton's improved Level . . . . .	394
Gravett's Level . . . . .	394
Levelling Staves . . . . .	395
Correction for Curvature . . . . .	395
Correction for Refraction . . . . .	396
To find the Differences of the Levels of several Points on the Earth's Surface, and to trace a Sectional Line of them . . . . .	397
The Datum Line . . . . .	400
Practical Level-Book . . . . .	400
Trial Levels . . . . .	401
Check Levels, and Survey of the Line . . . . .	402
Final Levels . . . . .	402
Level-Book . . . . .	404
Plotting the Main Section . . . . .	406
Cross Levels . . . . .	406
The Application of the Correction for Curvature and Refraction in Levelling . . . . .	407
Levelling by the Theodolite . . . . .	409
Levelling by the Aneroid Barometer . . . . .	409

## SECTION II.

Parliamentary Plan and Section, &c. . . . .	410
The Method of Laying out Gradients . . . . .	411

	PAGE
Tunnels . . . . .	412
To determine the Rate of Inclination of a Gradient . . . . .	412
Method of determining the Heights of Roads passed over or under by a Railway, &c. . . . .	413

## SECTION III.

## RAILWAY CURVES.

On the Use of Curves in Railways in general . . . . .	414
On Mechanical Railway Curves, or Curve-rulers . . . . .	415
The Limit of the Radii of Railway Curves . . . . .	415
PROB. 1. CASE I. To determine the radius of a railway curve mechanically . . . . .	416
II. To determine the radius of a railway curve geometrically . . . . .	417
III. To find the radius of the curve when the map is inaccurate . . . . .	417
IV. To find the radius when the tangents cannot be prolonged to meet . . . . .	418
PROB. 2. To lay out a railway curve by the common method . . . . .	418
3. To lay out a railway curve by offsets from its tangents . . . . .	420
CASE I. When the length of the curve is less than $\frac{1}{4}$ of its radius . . . . .	420
II. When the curve is any required length . . . . .	422
III. When the length of the curve exceeds the limit adopted in CASE I., but is considered too short to be divided into two parts as in CASE II. . . . .	424
4. To lay out the curve by two theodolites, where water, swamps, quarries, and other obstructions prevent the use of the chain . . . . .	424
5. To lay out the curve by offsets from its chord or chords, &c. . . . .	426
Definition of the Compound Curve . . . . .	427
PROB. 6. To find the several radii of the compound curve, &c. . . . .	428
Definition of the Serpentine or S Curve . . . . .	429
PROB. 7. (1.) When one radius and its tangential point are given, to find the other radius and tangential point of the serpentine curve geometrically . . . . .	429
(2.) When the tangential points and one of the radii of the serpentine curve are given, to find the other radius geometrically . . . . .	430
PROB. 8. (1.) When the two portions of the serpentine curve have the same radius, to determine that radius geometrically, the tangential points and their distance being given . . . . .	431
(2.) To find the common radius of the serpentine curve by calculation . . . . .	431
PROB. 9. To make a given deviation from a straight portion of a line of railway by means of three curves . . . . .	432
Remarks on laying out the Curves in the four last Problems . . . . .	433

## SECTION IV.

## RAILWAY EARTHWORKS.

On setting out the Width of Ground for a Railway . . . . .	434
PROB. 1. To set out the width when the surface of the ground is laterally on the same level as the intended railway . . . . .	434

	PAGE
PROB. 2. To set out the width of cuttings, or embankments, when the surface of the ground is laterally level, and at a given height above the intended railway, &c. . . . .	435
3. To set out the width of the cuttings, when the surface of the ground is laterally sloping, &c. . . . .	436
4. To set out the widths when the surface of the ground is laterally sloping, and when the cross-section of the works consists partly of a cutting and partly of an embankment, &c. . . . .	438
5. To find the width of cuttings when the surface is very uneven . . . . .	440
6. To find the quantity of land required for a projected railway, CASES I. and II. . . . .	441
On Railway Cuttings in general, and Tables for finding their Contents . . . . .	443
The General Earthwork Table (at the end of the book) . . . . .	444
PROB. 7. CASE I. To find the contents of cuttings by the General Earthwork Table and the Auxiliary Table No. I. . . . .	444
II. To find the contents of cuttings by the tables, when the depths are given in feet and decimals of feet . . . . .	446
8. CASE I. To find the content of a cutting between two cross-sections the areas of which, &c., are given . . . . .	448
II. When great accuracy is required, &c. . . . .	449
9. To find the contents of a railway cutting, when the slopes of the two sides are different . . . . .	449
CASE I. When the depths are given . . . . .	449
II. When the sectional areas are given . . . . .	450
10. To apply the general table and table No. II. to such bottom widths and ratios of slopes as are not found in table No. I. . . . .	450
11. To find the content of the cutting of a tunnel . . . . .	450
An Example showing the magnitude of the errors of several methods of finding the Contents of Cuttings . . . . .	450
Observations important to those concerned in the Construction of Railways, on the erroneous methods of calculating the contents of cuttings where the surface of the ground is uneven ; also on the method given in this work . . . . .	452
Investigation of the Construction and Use of the General and Auxiliary Tables . . . . .	452
The Errors of the methods of finding the Contents of Cuttings by Mr Bashforth and others . . . . .	455

## SECTION V.

Tunnelling . . . . .	458
A Table of the Dimensions of several existing Tunnels . . . . .	460

## SECTION VI.

## VIADUCTS, AQUEDUCTS, SKEW ARCHES, &amp;c.

The Brick Viaduct at Maidenhead . . . . .	460
The Viaduct over the Ouse at York . . . . .	461
Aqueduct of Pont-y-Cysyllte . . . . .	461
Skew-bridges—On the London and Birmingham Line . . . . .	462
Midland Counties Railway . . . . .	462
Manchester and Birmingham Railway . . . . .	463
Dimensions of Viaducts in various Railways . . . . .	463

SECTION VII.

	PAGE
Superelevation of Exterior Rail in Curves . . . . .	464
Tables for Reduction of Distances and Correction of Levels for Curvature, &c. . . . .	468
Tables of Offsets for Railway Curves, &c. . . . .	469

APPENDIX.

Acts of Parliament . . . . .	471
Improvement of Commons (1845) Act . . . . .	472
Forms for Valuer, &c. . . . .	494
List of Acts relating to Inclosures passed since 1845 . . . . .	499

INDEX TO PRINCIPAL ENGRAVINGS, PLATES, PLANS, &c.

PLATE	I. The Compass . . . . .	23
	II. Nesbit's Quadrant . . . . .	147
	III. Plan of an Estate (triangular method) . . . . .	160
	IV. Plan of an Estate (parallel method) . . . . .	163
	V. The Pentagraph . . . . .	191
	VI. Examples how to finish Plans with Indian ink—Meadows, Pastures, Corn Fields, and Moors . . . . .	197
	VII. Ditto—Marshy Grounds, Sands, Rocks, &c. . . . .	199
	XII. Plan of an Inclosed Common . . . . .	259
	VIII. Folded rough Plan of an Actual Survey . . . . .	End of work.
	IX. Folded finished Plan of the last (Plate VIII.) . . . . .	"
	X. Folded rough Plan of an Actual Survey . . . . .	"
	XI. Folded finished Plan of Survey (Plate X.) . . . . .	"
	XIII. Folded Parliamentary Plan and Section . . . . .	"
GENERAL AND AUXILIARY EARTHWORK TABLES FOR RAILWAYS . . . . .		"



EXPLANATION  
OF THE PRINCIPAL  
MATHEMATICAL CHARACTERS.

---

The sign or character = (called *equality*) denotes that the respective quantities between which it is placed are equal; as 4 poles = 22 yards = 1 chain = 100 links.

The sign + (called *plus*, or more) signifies that the numbers between which it is placed are to be added together; as 9 + 6 (read 9 *plus* 6) = 15. Geometrical lines are generally represented by capital letters; thus AB + CD signifies that the line CD is to be added to the line AB.

The sign - (called *minus*, or less) denotes that the quantity which it precedes is to be subtracted; as 15 - 6 (read 15 *minus* 6) = 9. In geometrical lines also, AB - CD signifies that the line CD is to be subtracted from the line AB.

The sign × denotes that the numbers between which it is placed are to be multiplied together; as 5 × 3 (read 5 multiplied by 3) = 15.

The sign ÷ signifies division; as 15 ÷ 3 (read 15 divided by 3) = 5. Numbers placed like a vulgar fraction also denote division; the upper number being the dividend, and the lower the divisor; as  $\frac{15}{3} = 5$ .

The signs : :: : (called *proportionals*) denote proportionality; as 2 : 5 :: 6 : 15, signifying that the number 2 bears the same proportion to 5, as 6 does to 15; or, in other words, as 2 is to 5, so is 6 to 15.

The sign  $\overline{\hspace{2cm}}$  (called *vinculum*) is used to connect several quantities together; as  $\overline{9 + 3} - \overline{6} \times 2 = \overline{12 - 6} \times 2 = 6 \times 2 = 12$ .

The sign <sup>2</sup>, placed above a quantity, represents the square of that quantity; as  $\overline{5 + 3}^2 = 8^2 = 8 \times 8 = 64$ .

The sign <sup>3</sup>, placed above a quantity, denotes the cube of that quantity; as  $\overline{9 + 3}^3 = \overline{12 - 8}^3 = 4^3 = 4 \times 4 \times 4 = 64$ .

The sign √ or  $\sqrt{\hspace{1cm}}$ , placed before a quantity, denotes the square root of that quantity; as  $\sqrt{9 \times 4} = \sqrt{36} = 6$ .

The sign  $\sqrt[3]{\hspace{1cm}}$ , placed before a quantity, represents the cube root of that quantity; as  $\sqrt[3]{6 \times 4 \times 3 - 8} = \sqrt[3]{24 \times 3 - 8} = \sqrt[3]{72 - 8} = \sqrt[3]{64} = 4$ .



**DIRECTIONS TO BOOKBINDER.**

**Plans VIII., IX., X., XI., XIII., and Earthwork Tables at the end of the work, in the order thus given :**

**Fold Plans VIII. and IX. to face each other when open.**

**Fold Plans X. and XI. to face each other when open.**

**Fold Plan XIII. to face, when open, the work.**

**Fold Earthwork Tables to face, when open, the work.**





# LAND-SURVEYING.

---

## PART I.

### DEFINITIONS, PROBLEMS, AND THEOREMS IN GEOMETRY.

GEOMETRY originally signified the art of MEASURING the EARTH, or any distance or dimensions upon, or within it; but it is now used for the science of quantity, extension, or magnitude.

---

### GEOMETRICAL DEFINITIONS.

1. A point is considered as having neither length, breadth, nor thickness.

2. A line has length, but is considered as having neither breadth nor thickness; as AB.

3. Lines are either right, curved, or parallel.

4. A right or straight line lies wholly in the same direction between its extremities, and is the shortest distance between two points; as AB.

5. A curved line continually changes its direction between its extremities; as AB.

6. Parallel lines always remain at the same distance from each other, and, though continually produced, would never meet; as AB and CD.

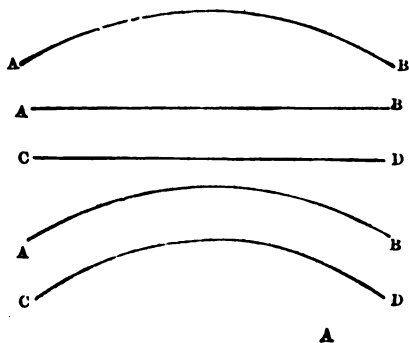

7. A surface or superficies has length and breadth, but is considered as having no thickness; as ABCD.

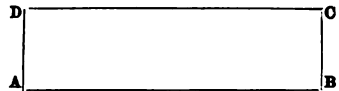

8. A superficies may be contained within one curved line, but cannot be contained within fewer than three straight lines.

9. The area of a figure is its superficial content, or the measurement of its surface.

10. An angle is the inclination or opening of two lines having different directions and meeting in a point, as at A, which is called the angular point; and, when three letters are used, the middle one denotes that point.

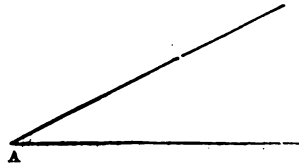

11. Angles are of three kinds, viz., right, acute, and obtuse.

12. A right angle is made by one right line standing perpendicularly upon another; thus, if DC be perpendicular to AB, the angles ADC and CDB are both right angles.

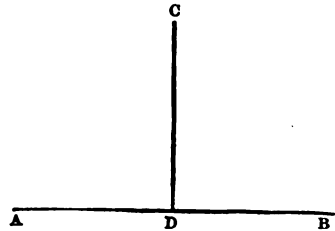

13. An acute angle is less than a right angle; as CAB.

14. The complement of an angle is what it wants to complete a right angle; as the angle DAB is the complement of the angle CAB.

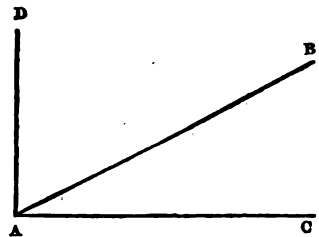

15. An obtuse angle is greater than a right angle; as BCD.

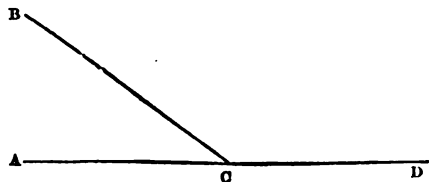

16. The supplement of an angle is what it wants of two right angles; as the angle ACB is the supplement of the angle BCD.

17. A triangle is a figure or superficies bounded by three right lines, and admits of three varieties; viz., equilateral, isosceles, and scalene.

18. An equilateral triangle has all its sides equal; as ABC.

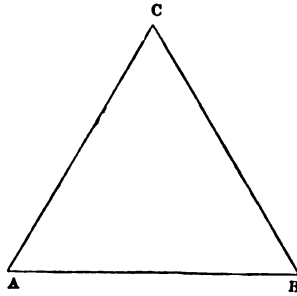

19. An isosceles triangle has only two of its sides equal; as ABC.

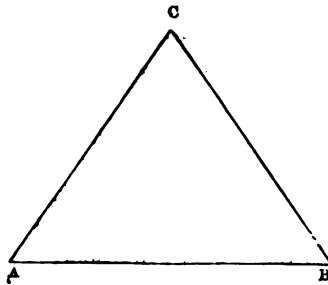

20. A scalene triangle has all its sides unequal; as ABC.

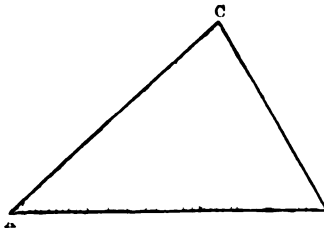

21. Triangles are also right-angled, acute-angled, and obtuse-angled.

22. A right-angled triangle has one right angle, the side opposite to which is called the hypotenuse, the other two being termed legs, or one the perpendicular, and the other the base; thus AC is the hypotenuse, BC the perpendicular, and AB the base.

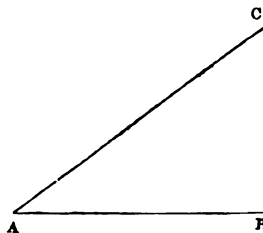

23. An acute-angled triangle has all its angles acute ; as  $\triangle ABC$ .

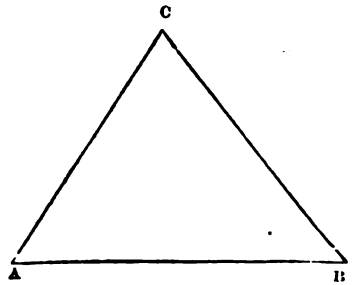

24. An obtuse-angled triangle has one obtuse angle ; as  $\triangle ACB$ .

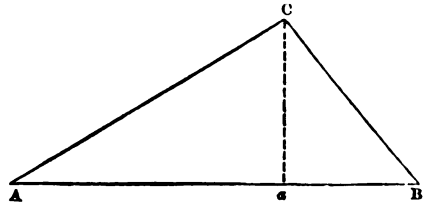

25. The longest side  $AB$  of the triangle  $ABC$  is called the base ; and the line  $Ca$  falling upon it at right angles from the opposite angle  $C$ , is called a perpendicular.

26. A figure of four sides and angles is denominated a quadrangle or quadrilateral figure.

27. A parallelogram is a quadrilateral figure, having its opposite sides parallel and equal, and admits of four varieties ; viz., the square, the rectangle, the rhombus, and the rhomboid.

28. A square is an equilateral parallelogram having all its angles right angles ; as  $ABCD$ .

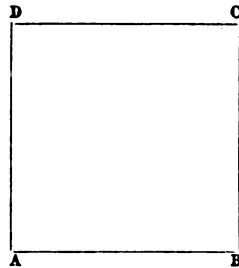

29. A rectangle is a parallelogram having its opposite sides equal and all its angles right angles ; as  $ABCD$ .

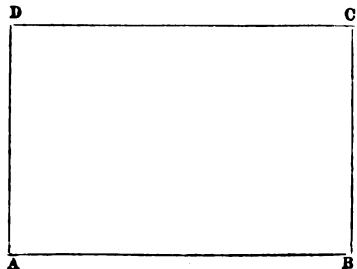

30. A rhombus is an equilateral parallelogram having its opposite angles equal : as ABCD.

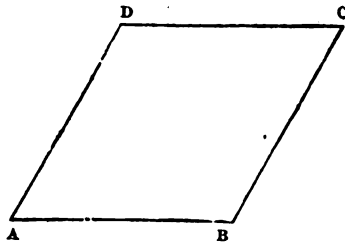

31. A rhomboid is a parallelogram having its opposite sides and angles equal ; as ABCD.

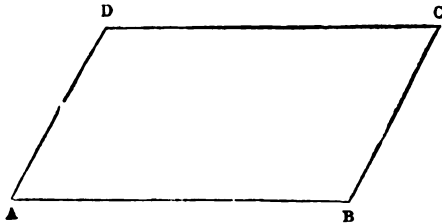

32. A trapezium is a quadrilateral figure whose opposite sides are not parallel to each other ; as ABCD.

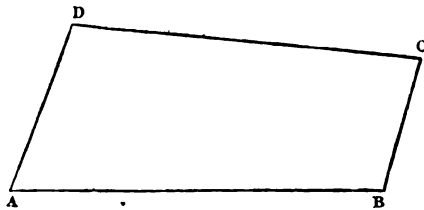

33. A trapezoid is a quadrilateral figure having two of its opposite sides parallel, and its angles, one acute, one obtuse, and two right-angled ; as AD is parallel to BC, the angles A and B are right angles ; the angle D is obtuse, and C acute.

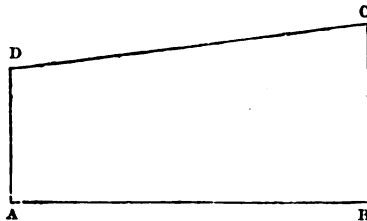

34. A diagonal is a right line joining the two opposite angles of a quadrilateral figure ; as AB.

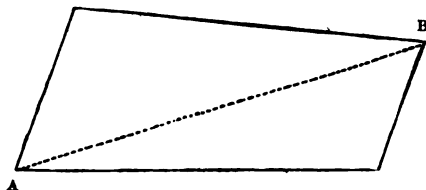

35. Plane figures having more than four sides are generally called polygons, and receive their particular denominations from the number of their sides or angles.

36. A pentagon is a polygon of five, a hexagon of six, a heptagon of seven, an octagon of eight, a nonagon of nine, a decagon of ten, an undecagon of eleven, and a duodecagon of twelve sides.

37. A regular polygon has all its sides and angles equal. When they are unequal the polygon is irregular.

38. A circle is a plane figure bounded by a curved line called the circumference, which is everywhere equidistant from a certain point within it, called the centre.

39. The circumference of every circle is supposed to be divided into 360 equal parts, called degrees; each degree into 60 equal parts, called minutes; and each minute into 60 equal parts, called seconds.

40. The diameter of a circle is a right line drawn through the centre, and terminating in the circumference on each side; as AB.

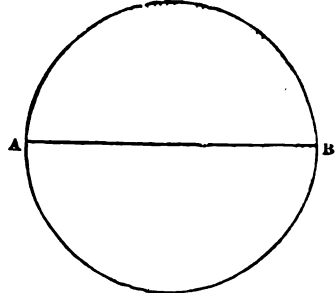
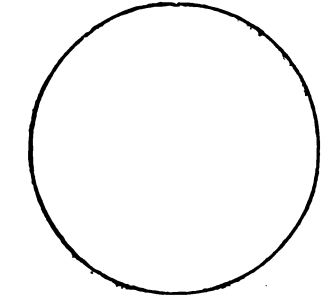

41. The radius of a circle is half the diameter, or it is a right line drawn from the centre to the circumference; as BA.

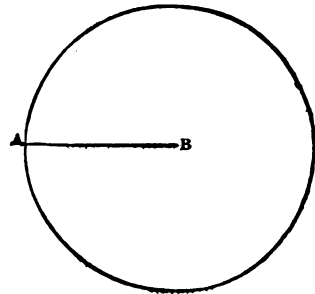

42. An arc of a circle is any part of the circumference; as the arc AB.

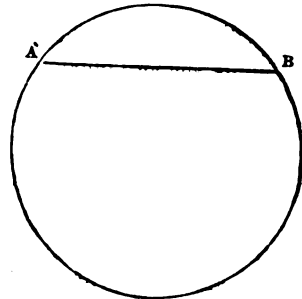

43. A chord is a right line joining the extremities of an arc ; as the line AB.

44. A segment is any part of a circle bounded by an arc and its chord.

45. A semicircle is half of a circle, or a segment cut off by the diameter ; as ABC.

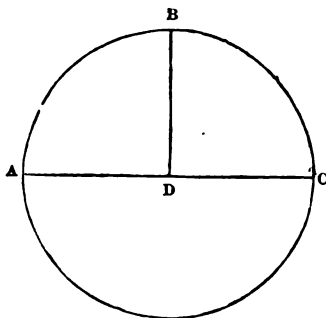

46. A sector is any part of a circle bounded by an arc and two radii.

47. A quadrant is the fourth part of a circle, or a sector bounded by an arc and two radii at right angles to each other ; as CDB.

*Corol.* Hence a right angle is said to contain  $90^\circ$ .

NOTE.—All Definitions and Rules should be committed to memory.

## GEOMETRICAL PROBLEMS.

### PROBLEM I.

*To bisect a given Line AB.*

From A and B as centres, with any radius greater than half AB, in your compasses, describe arcs cutting each other in  $m$  and  $n$ .

Draw the line  $mCn$ , and it will bisect AB in C.

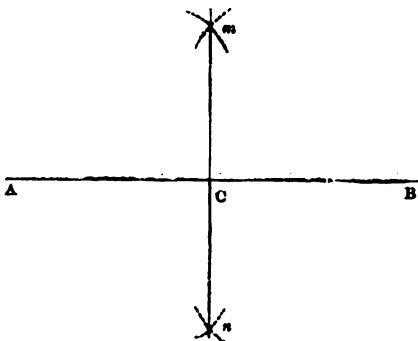



## PROBLEM II.

*To bisect a given Angle ABC.*

From the point B with any radius describe the arc AC. From A and C, with the same or any other radius, make the intersection  $m$ . Draw the line Bm, and it will bisect the angle ABC, as required.

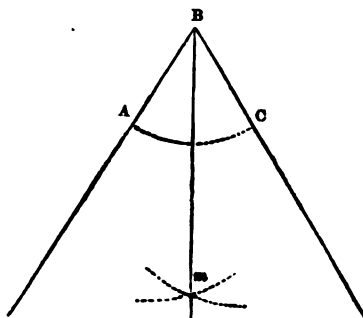

## PROBLEM III.

*To draw a Line parallel to a given Line AB at a given Distance.*

From any two points,  $m$  and  $n$ , in the given line, with the given distance as a radius, describe the arcs  $r$  and  $o$ . Draw CD to touch these arcs, without cutting them, and it will be parallel to AB.

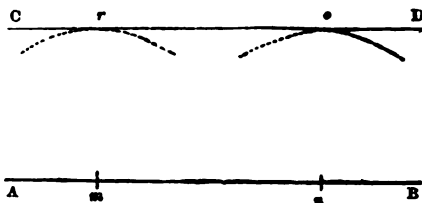

NOTE.—This problem may be more readily performed by a parallel ruler.

## PROBLEM IV.

*To erect a Perpendicular from a given Point C, near the middle of a given Line AB.*

On each side of the point C take two equal distances Cm and Cn; from  $m$  and  $n$  as centres, with any radius greater than Cm or Cn, describe two arcs cutting each other in  $r$ . Draw the line Cr, and it will be the perpendicular required.

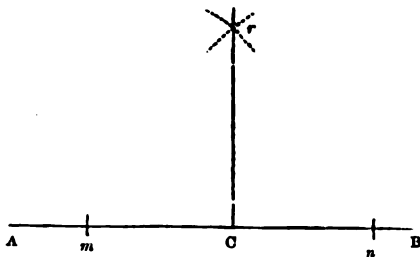

## PROBLEM V.

To erect a Perpendicular from a given Point  $C$ , near the End of a given Line  $AB$ .

From any point  $m$ , as a centre, with the radius or distance  $Cm$ , describe an arc cutting the given line in  $C$  and  $n$ .

Through  $n$  and  $m$  draw a line cutting the arc in  $r$ . Draw the line  $Cr$ , and it will be the perpendicular required.

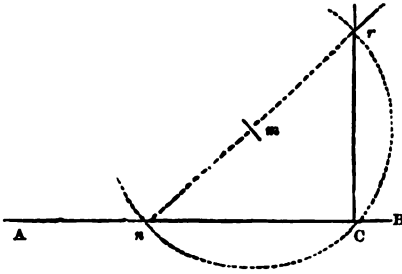

## PROBLEM VI.

From a given Point  $C$ , to let fall a Perpendicular upon a given Line  $AB$ .

With  $C$  as a centre, and any radius a little exceeding the distance of the given line, describe an arc cutting  $AB$  in  $m$  and  $n$ . With the centres  $m$  and  $n$ , and the same or any radius exceeding half their distance, describe arcs intersecting each other in  $r$ . Draw the line  $Cr$ , and  $CD$  will be the perpendicular required.

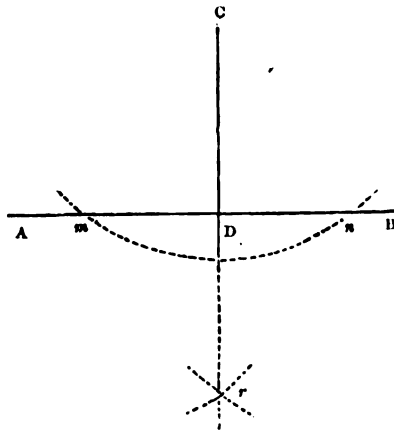

NOTE.—The last three problems may be easily performed by a square or a plotting scale.

## PROBLEM VII.

To make a Triangle with three given Lines, any two of which must be greater than the third (Euclid i. 22).

Let the given lines be  $AB=10$ ,  $AC=8$ , and  $BC=6$  chains.

From any scale of equal parts (which is to be understood as employed likewise in all the following problems) lay off the base  $AB$ .

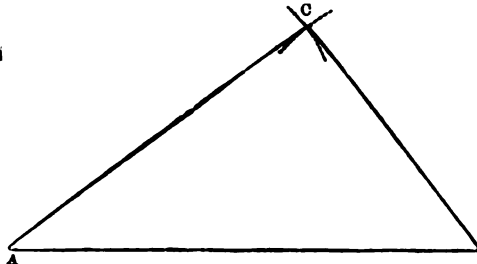

With the centre A and radius AC describe an arc. With the centre B and radius BC describe another arc cutting the former in C. Draw the lines AC and BC, and the triangle will be completed.

NOTE.—Any trapezium may be constructed in the same manner, when the four sides and one of the diagonals are given.

### PROBLEM VIII.

*Having given the Base, the Perpendicular, and the Place of the Perpendicular upon the Base, to construct a Triangle.*

Let the base  $AB = 9$ , the perpendicular  $CD = 5$ , and the distance  $AD = 6$  chains.

Make  $AB = 9$ , and  $AD = 6$ . At D erect the perpendicular DC, which make equal to 5. Join AC and BC, and the figure will be completed.

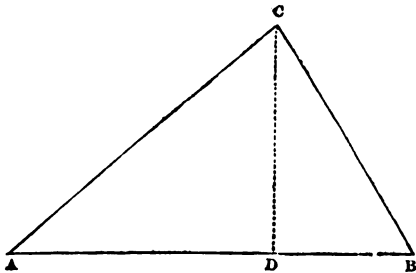

NOTE.—A trapezium may be constructed in a similar manner, when one of the diagonals, the two perpendiculars let fall thereon from the opposite angles, and the places of these perpendiculars upon the diagonal are given.

### PROBLEM IX.

*To describe a Square whose Side shall be equal to a given right Line.*

Let the given line  $AB = 4$  chains.

Upon one extremity B of the given line, by Problem V., erect the perpendicular BC, which make equal to AB.

With A and C as centres, and the radius AB, describe arcs cutting each other in D. Draw the lines AD and CD, and the square will be completed.

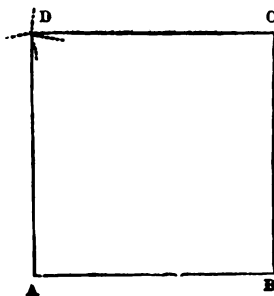

### PROBLEM X.

*To describe a Rectangular Parallelogram, whose Length and Breadth shall be equal to Two given Lines.*

Let the length  $AB = 8$ , and the breadth  $BC = 4$  chains.

At B erect the perpendicular BC, which make equal to 4. With A as a centre, and the radius BC, describe an arc; and with C as a centre, and the radius AB, describe another arc, cutting the former in D. Draw the lines AD and CD, and the rectangle will be completed.

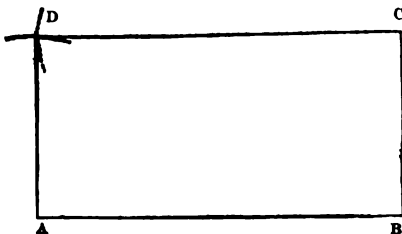

### PROBLEM XI.

*Upon a given Right Line to construct a Regular Rhombus.*

Let the given line  $AB = 4$  chains.

Draw the line AB equal to 4. With A and B as centres, and the radius AB, describe arcs cutting each other in D; then with B and D as centres, and the same radius, make the intersection C.

Draw the lines AD, DC, and BC, and the rhombus will be completed.

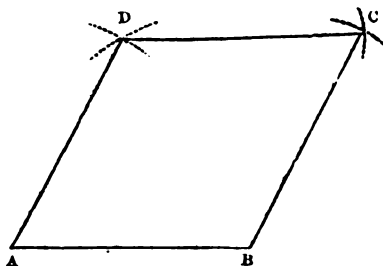

### PROBLEM XII.

*Having any Two Right Lines given, to construct a Rhomboid.*

Let the given lines be  $AB = 7$ , and  $BC = 4$  chains.

Draw the line AB equal to 7. Take in your compasses the line BC and lay it from A to E. With A and E as centres, and the radius AE, make the intersection D. Then with B as a centre, and the same radius, describe an arc; and with D as a centre, and the radius AB, describe another arc, cutting the former in C. Draw the lines AD, DC, and BC, and the rhomboid will be completed.

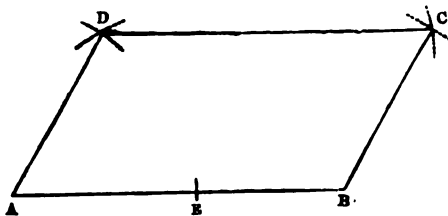

## PROBLEM XIII.

*Having the Base and the Two Perpendiculars given, to construct a Trapezoid.*

Let the base  $AB = 7$ , and the perpendiculars  $BC$  and  $AD = 3$  and  $2$  chains respectively.

Draw the base  $AB$ , equal to  $7$ , and erect the perpendiculars,  $BC$  equal to  $3$ , and  $AD$  equal to  $2$  chains. Then join  $DC$ , and the trapezoid will be completed.

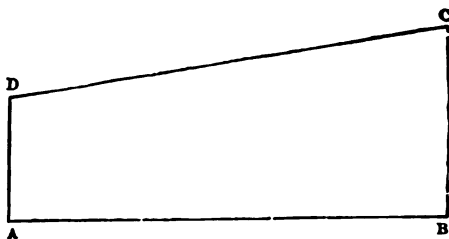

## PROBLEM XIV.

*Having the Four Sides given, to construct a Quadrilateral Figure which has one Right Angle.*

Let the sides  $AB = 7$ ,  $BC = 4$ ,  $CD = 6$ , and  $DA = 3$  chains; and let the angle at  $B$  be a right angle.

Draw the line  $AB$  equal to  $7$ , and erect the perpendicular  $BC$ , equal to  $4$  chains. With  $C$  as a centre, and the radius  $CD$ , describe an arc; and with  $A$  as a centre, and the radius  $DA$ , describe another arc, cutting the former in  $D$ . Draw the lines  $CD$  and  $DA$ , and the figure will be completed.

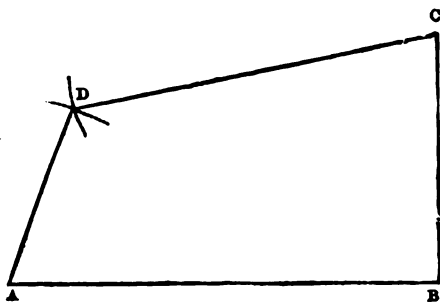

## PROBLEM XV.

*Having the Transverse and Conjugate Diameters given, to construct an Ellipsis.*

Let the transverse diameter  $AB = 7$ , and the conjugate diameter  $CD = 4$  chains.

Draw the two diameters to bisect each other perpendicularly in the centre  $o$ . With the radius  $ao$ , and the centre  $C$  or  $D$ , intersect  $AB$  in  $F$  and  $f$ . These points will be the foci of the ellipsis. Take any point  $m$ , in the transverse diameter, and with  $F$  and  $f$  as centres

and the radius  $Am$ , describe the arcs  $G, G$  and  $g, g$ . Then with the same centres and the radius  $Bm$ , describe arcs cutting the former in the

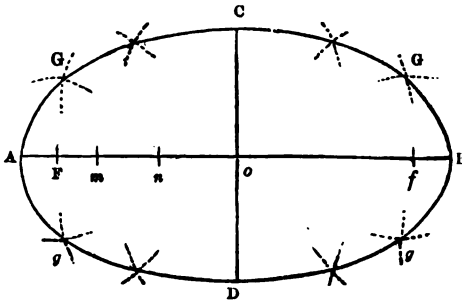

points  $G, G, g$  and  $g$ : thus will you have four points in the circumference of the ellipse. After this, take a second point  $n$ , in the transverse diameter, and, proceeding as before, you will determine other four points. By the same method you may determine as many more as you please; through all of which, with a steady hand, you must draw the circumference of the ellipse.

**NOTE.**—An ellipse may also be constructed as follows:—Having found the foci  $F$  and  $f$ , as before, take a thread equal in length to the transverse diameter  $AB$ , and fasten its ends, with two pins, in the points  $F$  and  $f$ ; then stretch the thread to its greatest extent; and by moving a pencil round, within the thread, keeping it always tight, you will trace out the curve of the ellipse.

The principle upon which this construction is founded may be seen in Prob. X. Part VI.

### PROBLEM XVI.

*To reduce a given Trapezium ABCD to a Triangle of equal area.*

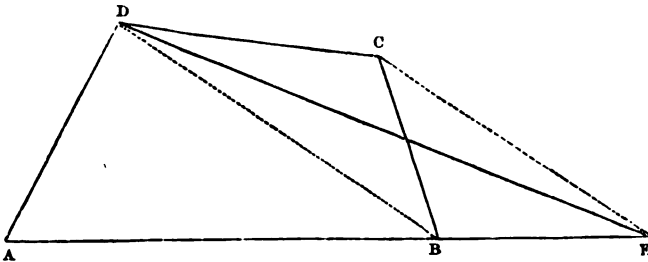

Draw the diagonal  $DB$ , and parallel to it draw  $CE$ , meeting  $AB$  produced in  $E$ . Draw  $DE$ ; the triangle  $ADE$  is equal to the trapezium  $ABCD$ .

**NOTE.**—This and the following problem may be applied in finding the areas of trapeziums and irregular polygons, by first reducing them to triangles.

## PROBLEM XVII.

To reduce an Irregular Polygon *ABCDE*, of five sides,  
to a Triangle of equal area.

Extend the side *AE* both ways at pleasure, and draw the diagonals *CE* and *CA*. Parallel to these diagonals draw the lines *DF*,

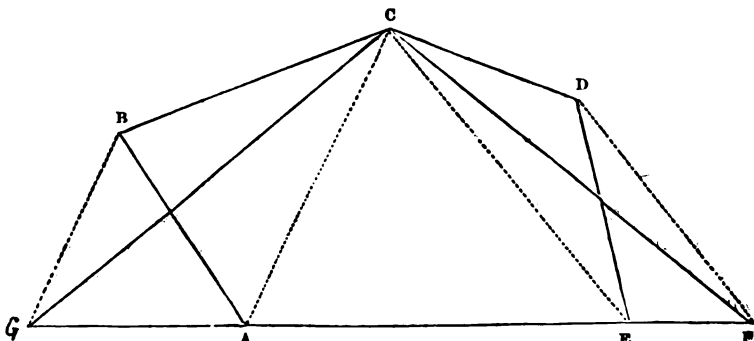

and *BG*; then draw *CF* and *CG*: and *GCF* will be the triangle required.

NOTE.—Any irregular polygon of more than five sides may be brought to a triangle of equal area by reducing it successively to a figure with one side less, until you bring it to a figure of three sides. Thus the trapezium *ABCF* or *GODE* is equal to the polygon *ABCDE* as well as the triangle *GCF*.

## PROBLEM XVIII.

To raise a Perpendicular from any Point *D*, in a given Line *AB*,  
by a scale of equal parts.

Make  $Dm = 3$ ; and from the points *D* and *m*, with the distances 4 and 5, describe arcs intersecting each other in *n*. From *D*, through the point *n*, draw the line *DC*, and it will be the perpendicular required.

NOTE.—This problem may be performed by any other numbers in the same proportion; but 3, 4, and 5 are the least whole numbers that will make a right-angled triangle.

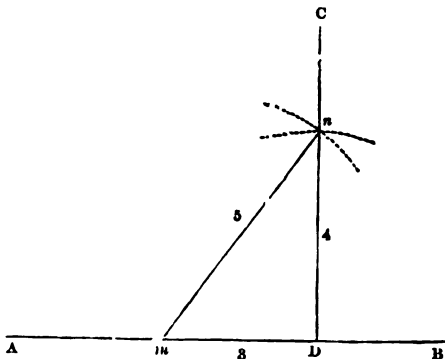

## PROBLEM XIX.

*To make a Right Angle by the Line of Chords on the Plane Scale.*

Draw the unlimited line AB; then take in your compasses  $60^\circ$  from the line of chords, and with B as a centre describe the arc ED. Take  $90^\circ$  from the same scale, and set off that extent from D to C. Draw the line AC, and CAD will be the angle required.

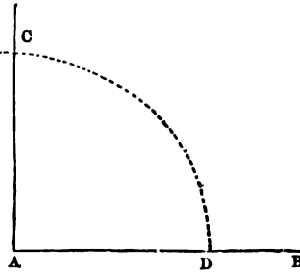

## PROBLEM XX.

*To make an Acute Angle equal to any Number of Degrees, suppose  $33^\circ 30'$ .*

Draw the unlimited line AB; then take  $60^\circ$  in your compasses, and with A as a centre describe the arc ED. Then set off the angle  $33^\circ 30'$  from D to C. Draw the line AC; and CAD will be the angle required.

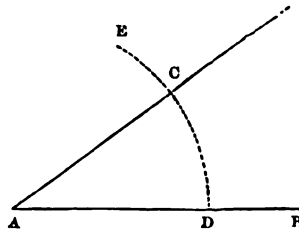

## PROBLEM XXI.

*To make an Obtuse Angle equal to any Number of Degrees, suppose  $125^\circ 30'$ .*

Draw the unlimited line AB; then take  $60^\circ$  in your compasses, and with A as a centre describe the arc ED. Then set off  $90^\circ$  from D to C; and from C to G set off the excess above  $90^\circ$ , which is  $35^\circ 30'$ . Draw the line AG; and GAD will be the angle required.

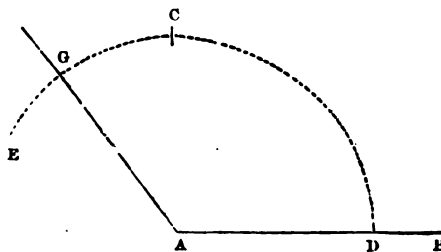



## PROBLEM XXII.

To find the Number of Degrees contained in any given Angle BAC.

With the chord of  $60^\circ$ , and A as a centre, describe the arc  $mn$ . Take the distance  $mn$  in your compasses, and apply it to the line of chords; and it will show the number of degrees required.

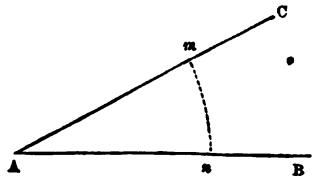

NOTE.—Angles may be more expeditiously laid down or measured by means of a semicircle of brass called a Protractor, the arc of which is divided into  $180^\circ$ .

## PROBLEM XXIII.

To lay down a Line making a given Angle with the Meridian, or North and South Line.

## EXAMPLES.

1. Let it be required to lay down a line that ranges N.E., making an angle of  $45^\circ$  with the meridian line. (See The Compass, Part II.).

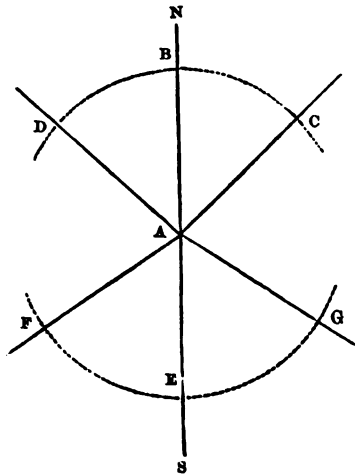

Draw the meridian line AN; and with the sweep of  $60^\circ$ , taken from the line of chords in your compasses, and A as a centre, describe the arc BC.

Set off the given angle  $45^\circ$  from B to C; draw the line AC, and it will range N.E., as was required.

NOTE.—If the line had ranged N.W., the angle must have been set off on the other side of the meridian AN; and AD would have been the direction of the line.

2. Lay down a line that ranges S.W. b. W., making an angle of  $26^{\circ} 15'$  with the meridian line.

Draw the meridian line AS; and with the chord of  $60^{\circ}$  describe the arc EF.

Set off  $56^{\circ} 15'$  from E to F; draw the line AF, and it will range S.W. b. W., as was required.

NOTE 1.—If the line had ranged S.E. b. E. the angle must have been set off from E to G; and AG would have been the direction of the line.

2. This problem will be found useful to young surveyors in laying down the first line, the range of which should be taken in the field by a compass.

## GEOMETRICAL THEOREMS,

THE DEMONSTRATIONS OF WHICH MAY BE SEEN IN THE WORKS OF EUCLID, SIMPSON, AND EMERSON.

### THEOREM I.

If two straight lines AB and CD cut each other in the point E, the angle AEC will be equal to the angle DEB, and CEB to AED (*Euclid*, i. 15; *Simpson*, i. 3; *Emerson*, i. 2).

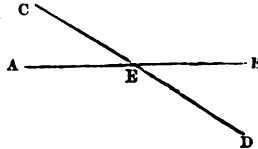

### THEOREM II.

The greatest side of every triangle is opposite to the greatest angle (*Eucl.* i. 18; *Simp.* i. 13; *Em.* ii. 4).

### THEOREM III.

Let the right line EF fall upon the parallel right lines AB and CD; the alternate angles AGH and GHD are equal to each other; and the exterior angle EGB is equal to the interior and opposite upon the same side GHD; and the two interior angles BGH and GHD upon the same side are together equal to two right angles (*Eucl.* i. 29; *Simp.* i. 7; *Em.* i. 4).

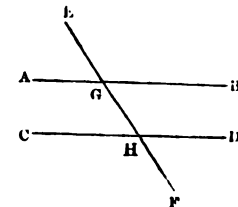

B

## THEOREM IV.

Let  $ABC$  be a triangle, and let one of its sides  $BC$  be produced to  $D$ ; the exterior angle  $ACD$  is equal to the two interior and opposite angles  $CAB$  and  $ABC$ ; also the three interior angles of every triangle are together equal to two right angles (*Eucl. i. 32*; *Simp. i. 9, 10*; *Em. ii. 1, 2*).

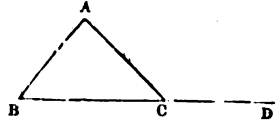

## THEOREM V.

Let the parallelograms  $ABCD$  and  $DBCE$  be upon the same base  $BC$ , and between the same parallels  $AE$  and  $BC$ ; the parallelogram  $ABCD$  is equal to the parallelogram  $DBCE$  (*Eucl. i. 35*; *Simp. ii. 2*; *Em. iii. 6*).

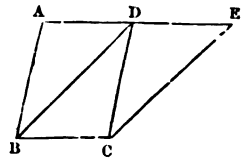

## THEOREM VI.

Let the triangles  $ABC$  and  $DBC$  be upon the same base  $BC$ , and between the same parallels  $AD$  and  $BC$ ; the triangle  $ABC$  is equal to the triangle  $DBC$  (*Eucl. i. 37*; *Simp. ii. 2*; *Em. ii. 10*).

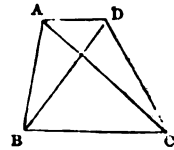

## THEOREM VII.

Let  $ABC$  be a right-angled triangle, having the right angle  $BAC$ ; the square of the side  $BC$  is equal to the sum of the squares of the sides  $AB$  and  $AC$  (*Eucl. i. 47*; *Simp. ii. 8*; *Em. ii. 21*).

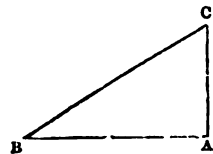

## THEOREM VIII.

Let  $ABC$  be a circle, and  $BDC$  an angle at the centre, and  $BAC$  an angle at the circumference, which have the same arc  $BC$  for their base; the angle  $BDC$  is double of the angle  $BAC$  (*Eucl. iii. 20*; *Simp. iii. 10*; *Em. iv. 12*).

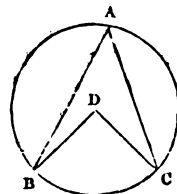

## THEOREM IX.

Let  $ABC$  be a semicircle; then the angle  $ABC$  in that semicircle is a right angle (*Euc.* iii. 31; *Simp.* iii. 13; *Em.* vi. 14).

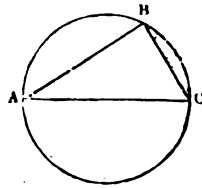

## THEOREM X.

Let  $DE$  be drawn parallel to  $BC$ , one of the sides of the triangle  $ABC$ ; then  $BD$  is to  $DA$  as  $CE$  to  $EA$  (*Euc.* vi. 2; *Simp.* iv. 12; *Em.* ii. 12).

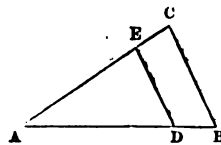

## THEOREM XI.

In the preceding figure,  $DE$  being parallel to  $BC$ , the triangles  $ABC$  and  $ADE$  are similar; therefore  $AB$  is to  $BC$  as  $AD$  to  $DE$ ; and  $AB$  is to  $AC$  as  $AD$  to  $AE$  (*Euc.* vi. 4; *Simp.* iv. 12; *Em.* ii. 13).

## THEOREM XII.

Let  $ABC$  be a right-angled triangle, having the right angle  $BAC$ ; and from the point  $A$  let  $AD$  be drawn perpendicularly to the base  $BC$ ; the triangles  $ABD$  and  $ADC$  are similar to the whole triangle  $ABC$ , and to each other. Also the perpendicular  $AD$  is a mean proportional between the segments of the base; and each of the sides is a mean proportional between the base and its segment adjacent to that side; therefore  $BD$  is to  $DA$  as  $DA$  to  $DC$ ;  $BC$  is to  $BA$  as  $BA$  to  $BD$ ; and  $BC$  is to  $CA$  as  $CA$  to  $CD$  (*Euc.* vi. 8; *Simp.* iv. 19; *Em.* vi. 17).

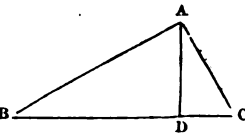

## THEOREM XIII.

Let  $ABC$  and  $ADE$  be similar triangles, having the angle  $A$  common to both; then the triangle  $ABC$  is to the triangle  $ADE$  as the square of  $BC$  to the square of  $DE$ . That is, similar triangles are to one another in the duplicate ratio of their homologous sides (*Euc.* vi. 19; *Simp.* iv. 24; *Em.* ii. 18).

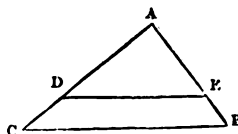

## THEOREM XIV.

In any triangle  $ABC$ , double the square of a line  $CD$ , drawn from the vertex to the middle of the base  $AB$ , together with double the square of half the base  $AD$  or  $BD$ , is equal to the sum of the squares of the other sides  $AC$  and  $BC$  (*Simp.* ii. 11 ; *Em.* ii. 28).

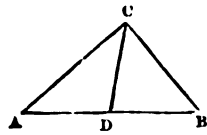

## THEOREM XV.

In any parallelogram  $ABCD$ , the sum of the squares of the two diagonals  $AC$  and  $BD$  is equal to the sum of the squares of all the four sides of the parallelogram (*Simp.* ii. 12 ; *Em.* iii. 9).

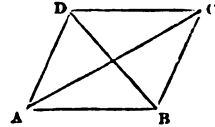

## THEOREM XVI.

All similar figures are in proportion to each other as the squares of their homologous sides (*Simp.* iv. 26 ; *Em.* iii. 20).

## THEOREM XVII.

The circumferences of circles, and the arcs and chords of similar segments, are in proportion to each other as the radii, or diameters, of the circles (*Em.* iv. 8, 9).

## THEOREM XVIII.

Circles are to each other as the squares of their radii, diameters, or circumferences (*Em.* iv. 35).

## THEOREM XIX.

Similar polygons described in circles are to each other as the circles in which they are inscribed, or as the squares of the diameters of those circles (*Em.* iv. 36).

## THEOREM XX.

All similar solids are to each other as the cubes of their like dimensions (*Em.* vi. 24).

## PART II.

A DESCRIPTION OF THE CHAIN, CROSS-STAFF, OFFSET-STAFF, COMPASS, AND FIELD-BOOK; ALSO DIRECTIONS TO YOUNG SURVEYORS WHEN IN THE FIELD; &c.

---

## THE CHAIN.

LAND is commonly measured with a Chain, invented by Mr Gunter, known by the name of 'Gunter's Chain.'

It is 4 poles, 22 yards, or 66 feet in length, and divided into 100 equal parts, called links; each link being 7.92 inches. At every tenth link from each end is fixed a piece of brass with notches or points; that at 10 links having one notch or point; at 20, two; at 30, three; and at 40, four points. At 50, or the middle, is a large round plain piece of brass.

The chain being thus marked, the links may be easily counted from either end; the mark at 90, 80, &c. being the same as that at 10, 20, &c. Part of the first link, at each end, is made into a large ring or bow, for the ease of holding it in the hand.

The chain should always exceed 22 yards, by an inch and half or two inches; because, in surveying, it is almost impossible to go in a direct line, or to keep the chain perfectly stretched. Long arrows likewise keep the ends of the chain a considerable distance from the ground; the lines, consequently, will be made longer than they are in reality.

Chains, when new, are seldom a proper length; they ought always, therefore, to be examined; as should those likewise which are stretched by frequent use.

**NOTE 1.**—In folding up the chain, it is most expeditious to begin at the middle, and fold it up double. When you wish to unfold it, take both the handles in your left hand, and the other part of the chain in your right; then throw it from you, taking care to keep hold of the handles. You must then adjust the links before you proceed to measure.

**2.** Chains which have three rings between each link are much better than those which have only two, as they are not so apt to twist.

## THE CROSS-STAFF.

The Cross-Staff is an instrument used in the field by surveyors, to erect perpendiculars, and may very easily be made in the following manner.

Procure a piece of board about 6 inches square, either of sycamore, box, or mahogany.

Draw the two diagonals, and at their extremities fix four small studs or pins, which will serve as sights to direct to any object or angle.

Or, instead of studs or pins, you may saw two fine grooves at right-angles, about a quarter of an inch deep, in the board.

This being fixed upon a staff, of a convenient length for use, pointed with iron at the bottom to enter the ground readily, the instrument is called a cross-staff.

Suppose  $abcd$ , to represent a cross, and the groove  $ac$  to be directed to an object at  $m$ ; then will the groove  $bd$  point to another at  $n$ .

Reverse the direction of the grooves, so that  $bd$  may be in the direction of  $m$ , then if  $ac$  be in the direction of  $n$  the instrument is correct.

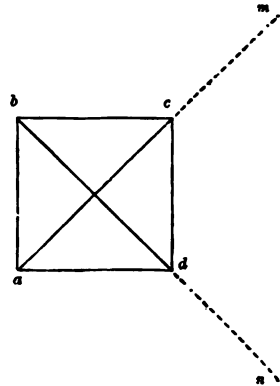

NOTE 1.—The cross must be fixed upon the top of the staff, in such a manner that it may be easily turned without moving the staff itself.

2. The cross may be made of a circular piece of board; you must then draw two diameters crossing each other at right angles. The fourth part of a circle will answer the purpose equally well.

3. Great care ought to be taken in making this instrument, as its accuracy depends on the sights, or grooves, being at right angles with each other.

## THE OFFSET-STAFF.

The Offset-Staff is an instrument used to measure short distances; and may be in length 10, 12, or 15 links. It would be advisable to number the links from each end, on opposite sides, with the figures 1, 2, 3, &c., as the staff thus marked will be more convenient for use.

NOTE.—As the cross-staff is sometimes thought incommodious, a small pocket-cross may be so contrived as to be readily fixed, upon occasion, to the offset-staff. This may be most expeditiously accomplished by means of a hole made through the cross, admitting the top of the staff, to the eighth link, counting from the bottom or piked end; at which place there must be attached a small shoulder, upon which the cross will rest.

## THE COMPASS.

The Compass is an instrument used by surveyors, to point out the range or direction of lines, and also to show the bearings of objects. The circumference of the card of the compass contains  $360^\circ$ , and is divided into thirty-two equal parts, called Points, each containing  $11^\circ 15'$ .

Of these, the four principal (namely, East, West, North, and

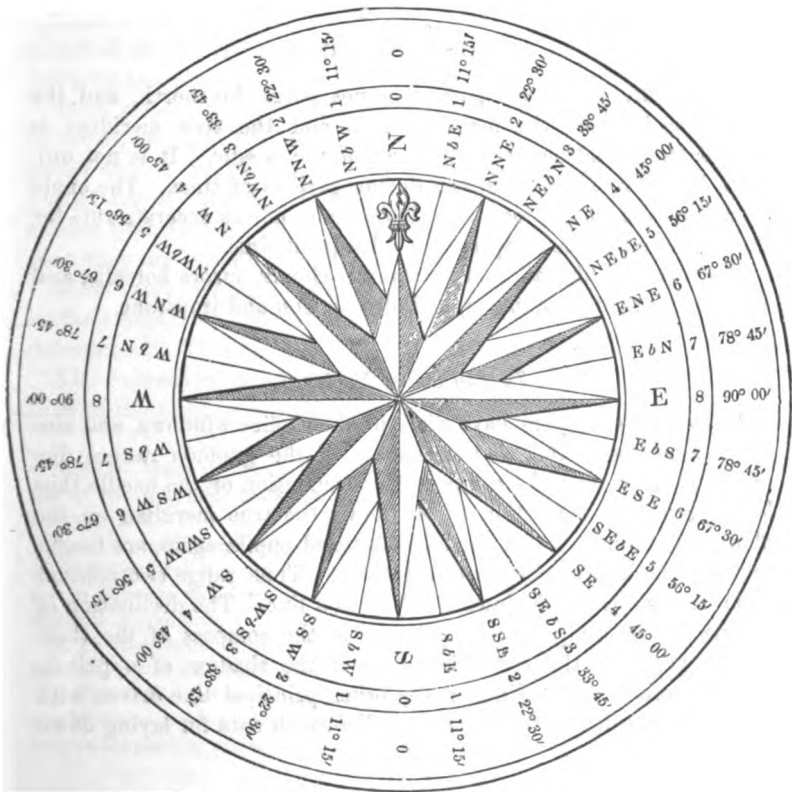

South) are called Cardinal Points ; from which the names of the others are derived.

To the under-side of the card, and in the direction of its north and south lines, is attached a magnetic bar of hardened steel, called the Needle, by which the north-point is directed towards the northern part of the horizon ; and the other points, consequently, to their corresponding ones in the heavens.



The card and needle are suspended on an upright pin, called the Supporter, which is fixed in the bottom of a brass or wooden box ; and the whole is covered with a plate of glass to prevent the action of the wind upon the card.

Although the compass is divided into thirty-two points, yet surveyors reduce them to eight, namely, the four cardinal or chief points, and the four midway between them, viz., the north-east, north-west, south-east, and south-west, which may be expressed by their initial letters, as E., W., N., S. ; N.E., N.W., S.E., S.W.

#### *Variation of the Needle.*

The needle of the compass does not point due north, and the difference between the magnetic pole and the true meridian is termed the variation or declination of the needle. It is not uniform, but increases or decreases during periods of time. The angle of declination at any one time is therefore not an accurate rule for the correction of the compass at a subsequent time.

The needle is also affected by thunder-clouds, aurora borealis, and similar electrical phenomena, and also by iron and ironstone.

#### *To find a true Meridian.*

Many land-surveyors have dials in their office windows, and also a small compass ; and as the shadow of the gnomon ranges due north at noon over the compass, the declination of the needle thus found gives the correction to lay down the true meridian on the plan. Others have a dial outside. Articled pupils, again, are taught in the field how to correct the compass. Thus, range two poles at noon so that their shadows shall be in a line. The declination of the needle of the pocket-compass, or of the compass of the theodolite, will give the correction. Or if the shadow of a pole is made to cross a main-line, or any other principal line driven with the chain, the angle thus formed will furnish data for laying down the meridian.

#### THE FIELD-BOOK.

Scarcely any two surveyors set down their field-notes exactly in the same manner. The method, however, now generally adopted, is to begin at the bottom of the page and write upward.

Each page of the book must be divided into three columns. In the middle column must be set down the distances on the chain-line at which any mark, offset, or other observation is made ; and in the

right and left-hand columns respectively those marks, offsets, and observations must be entered.

The crossings of fences, rivers, &c. may be denoted by lines drawn across the middle column, or part of the right and left-hand columns, opposite the distances on the chain-line at which they are crossed; and the corners of fields, and other remarkable turns in the fences, to which offsets are taken, may be denoted by lines joining or lying in the same relation to the middle column as the fences, &c. do to the chain line.

Thus a tolerably accurate representation of the fences, &c. may be sketched in the field, which will very much assist the surveyor in drawing the plan.

With respect to the characters used to denote stations, the letters of the alphabet will do very well in small surveys; but in those of a larger extent, numeral figures must be used, and the sign + (plus) placed before each figure; thus, + 1, or + 2, which may be read station first, or cross first; station one, or cross one, &c. Upon the plan they are generally represented by this ( ⊙ ) mark.

Most surveyors take the exact range of the first line, and enter it in their field-book; and from it the range of any other may be easily determined. This method I shall adopt in the following work.

The expression, R. off B, or L. off B, &c. denotes that you are to turn to the right or left hand, and measure from B, &c.

NOTE 1.—Many surveyors not only begin at the bottom of the field-book, but also at its right-hand side, and write toward the left, which method I generally follow myself.

2. It is useful for a beginner to draw a rough sketch of the field, or estate which he is about to measure; and upon it to note the stations in the same manner as they are put down in taking the survey. This will materially assist his memory in planning.

3. The field-book, for practical use, should be made convenient for the pocket, and interleaved with blotting-paper.

4. The field-notes should always be set down with ink, which may be carried in a bottle suspended from a button of your waistcoat. Double fountain-bottles, such as are used by excise officers, are the best.

### DIRECTIONS TO YOUNG SURVEYORS WHEN IN THE FIELD, &c.

In addition to the instruments already described, you must provide ten arrows, each about a foot in length, made of strong wire, and pointed at the bottom. These should be bent in a circular form

at the top, for the convenience of holding them, and a piece of red cloth should be attached to each, that they may be more conspicuous among long grass, &c.

Poles, likewise, generally called Ranging-poles, or Station-staves, will be wanted as marks, or objects of direction, each about ten feet in length, piked with iron at the bottom, and having a red or white flag at the top, that they may be better seen at a distance. Thus equipped, and having entered the field or estate which you are about to survey, first, make yourself acquainted with its form; and then consider in what manner you must run your lines, according to the directions hereafter given in Parts III., IV., V.; after which you must proceed in the following manner.

Let your assistant or chain-leader take nine arrows in his left-hand, and one end of the chain with one arrow in his right; then, advancing toward the place directed, at the end of the chain, let him put down the arrow which he holds in his right hand. This the follower must take up with his chain-hand when he comes to it, the leader, at the same time, putting down another at the other end of the chain. In this manner he must proceed until he has put down his tenth arrow; then, advancing a chain farther, he must set his foot upon the end of the chain, and call out "change." The surveyor, or chain-follower, must then come up to him, if he have no offsets to take, and carefully count to him the arrows; and one being put down at the end of the chain, proceed as before, until the whole line be measured.

Each change ought to be entered in the field-book, or a mistake of 10 chains may happen, when the line is very long. The chain-follower ought to be careful that the leader always puts down his arrow perpendicularly, and in a right-line with the object of direction; otherwise the line will be made longer than it is in reality. The follower may direct the leader by the motion of his left-hand; moving it to the right or left, as circumstances require, and always placing his eye and chain-hand directly over the arrow which is stuck in the ground. The leader likewise, as soon as he has put down his arrow, ought to fix his eye upon the object of direction, and go directly toward it. This he may easily effect by finding a tree or a bush beyond the station to which he is going, and in a straight line with it and himself.

In hilly ground, if the follower lose sight of the mark toward which he is going, he must stand over his arrow; and the leader must move to the right or left, till he sees the follower in a direct line between himself and the mark from which they last departed.

The surveyor ought to put down at each station a small stake, called a station-stake, with the number of the station upon it; so that

any of the stations may be readily found, if there be occasion to measure the distance between two of them, as a tie or proof-line, &c.

In large surveys, there must be a cross cut in the ground, at each station, making right-angles with the chain-line; so that if the stake should be pulled up, the cross may still remain, and serve as a director.

When a survey is taken with an intent to draw a finished plan, all remarkable objects should be noted down in the field-book; as roads, stiles, gates, trees, &c.

If the surveyor can conveniently procure two assistants, the one to lead the chain and the other to follow it, it will be much to his advantage; as he will thus be left at liberty to take offsets, note down dimensions, &c., without loss of time.

He ought always to observe to whom the boundaries belong.

If the ditch be in the field he is about to measure, both it and the hedge usually belong to the adjoining field. This, however, is not always the case; as it sometimes happens that the hedge is on the reverse side of the ditch. It is advisable, therefore, to inquire of some person resident on the spot concerning the hedges, &c.

In some places 3 feet from the roots of the quickwood are allowed for the breadth of the ditches; in some 4, in some 5, and in some 6; but 4 feet, or 6 links, are commonly allowed for ditches between neighbouring estates, and 7 links for ditches adjoining roads, commons, waste lands, &c.

The ditches and fences must always be measured with the fields to which they belong, when the whole quantity of land is required; but in measuring crops of corn, turnips, &c., only so much must be measured as is or has been occupied by the corn, &c.

Upon the surveyor depends all the care of measuring, remarking, noting down, &c. It absolutely behoves him, therefore, to be not only particularly careful in his entries, and correct in his dimensions, but also extremely accurate in his constructions and calculations.

NOTE.—The line in which you have the misfortune to lose an arrow must be remeasured.

### DIRECTIONS CONCERNING SCALES, LAYING DOWN FIGURES, &c.

Any scale of equal parts may be used in planning, or laying down figures; but that which is most convenient for use is the ivory plotting-scale, so divided on its edges that you may prick off distances by laying it upon the line.

In laying down an offset by the plotting-scale, it is best, first, to

prick off the base-line, and then upon it make a small pencil dot at every place where a perpendicular must be erected.

This being done, lay the scale across the base, so that the perpendicular line which goes across the scale, marked with  $\infty$ , may coincide with the base, the edge of the scale at the same time touching one of the dots. From the dot, by the edge of the scale, draw a line (which will be perpendicular to the base), and upon it prick off the offset; or it may be pricked off without drawing a line.

Proceed thus till all the perpendiculars are erected, and then draw the fence through each of their extremities. If the fence be curved, it must be drawn by a steady hand, in the same manner as the circumference of an ellipse. (See p. 13).

In planning, or laying down figures relating to surveying, the upper part of the paper or book used should always, if possible, represent the north. All the fences and chain-lines should first be pencilled: the first should then be drawn, and the latter dotted with ink. Great accuracy is required in the construction of figures, when the perpendiculars, &c., are to be measured by the scale. The lines should be very fine, the dots at the stations very small, and the points of the compass very sharp, in order that distances may be taken from the scale with the utmost correctness. The scale should never be smaller than two chains to an inch; for when its divisions are large, figures may be constructed with much more accuracy, and their perpendiculars, &c. measured with much greater exactness.

After having found the area of any field or estate, you may, however, lay it down by any scale that will reduce it to a more convenient size. Or you may divide the dimensions by 2, 3, 4, &c., in order to make them of a proper size to be laid down by a scale of 2, 3, or 4 chains to an inch.

NOTE 1.—A plotting-scale divided into two chains to an inch on one of its edges, and four on the other, is perhaps most useful for a school-boy; but practical surveyors prefer those which have both their edges divided in the same manner, because they are more convenient in planning; and a mistake cannot be made by using one edge instead of the other.

2. Many plotting-scales are now made of box, without the perpendicular line across them; and a small scale, called an 'offset-scale,' is used in laying down the offsets. In using these scales, the first line or division, on the plotting-scale, is made to coincide with the commencement of the base-line; and the end of the offset-scale is then brought in contact with the edge of the plotting-scale; and thus the offsets may be pricked off, without drawing the offset lines perpendicular to the base-line.

3. An instrument called a Pricker, which may be made by putting a fine needle into a wooden haft, is used by some persons, in pricking off distances from the plotting-scale; but a hard black-lead pencil, finely pointed, is preferable, because it does not injure the paper.

## PART III.

TO SURVEY WITH THE CHAIN AND CROSS; ALSO TO MEASURE MERES, WOODS, AND LINES UPON WHICH THERE ARE IMPEDIMENTS.

---

CONFORMABLY to a statute of 34 Henry VIII. an acre of land is equal to 10 square chains; that is, 10 chains in length and 1 in breadth; or  $220 \times 22 = 4840$  square yards; or  $40 \times 4 = 160$  square rods, poles, or perches.

A statute pole or perch is  $16\frac{1}{2}$  feet in length; but in different parts of the kingdom there were, by custom, poles of different lengths; as 15, 18, 21 feet, &c.

The various dimensions of a piece of land are taken in lineal measure, from which its area or content is calculated in superficial measure.

NOTE 1.—The method of reducing statute measure to customary, and the contrary, may be seen in Part VI.

2. By the Act 5 Geo. IV. Chap. 74, it is enacted that our present yard shall be called 'The Imperial Standard Yard;' that one-third part thereof shall be a foot, and the twelfth part of such foot shall be an inch; and that the rod, pole, or perch, in length, shall be  $5\frac{1}{2}$  yards, the furlong 220 yards, and the mile 1760 yards.

3. By the same statute it is enacted that all superficial measures shall be computed by the 'Standard Yard,' or by certain parts or portions thereof; that the rod of land shall be 1210 square yards, and the acre of land 4840 square yards.

4. By the Act 5 & 6 Will. IV. Chap. 63, all *local* or *customary* weights and measures are abolished; but still it may be necessary to give the methods of reducing *local* or *customary* measures of land to statute measure, as in many *old plans* the contents are given in *local* or *customary* MEASURES.

A TABLE OF LINEAL MEASURES.

Inches	Link							
7·92 =	1	Foot						
12	1·5151 =	1	Yard					
36	4·5454	3 =	1	Stat. Perch				
198	25	16·5	5·5 =	1	Chain			
792	100	66	22	4 =	1	Fur-long		
7920	1000	660	220	40	10 =	1	Mile	
63360	8000	5280	1760	320	80	8 =	1	

A TABLE OF SQUARE MEASURES.

Square Inches	Square Link							
62·7264 =	1	Square Foot						
144	2·2956 =	1	Square Yard					
1296	20·6611	9 =	1	Square Perch				
39204	625	272·25	30·25 =	1	Square Chain			
627264	10000	4356	484	16 =	1	Square Rood		
1568160	25000	10890	1210	40	2·5 =	1	Square Acre	
6272640	100000	43560	4840	160	10	4 =	1	Square Mile
4014489600	64000000	27878400	3097600	102400	6400	2560	640 =	1

## PROBLEM I.

*Square Fields.*

When you enter a field, which has the appearance of a square (for few are accurately such), fix your cross-staff in a corner of it, and if

the two sides be at right angles, measure one of them, and enter its dimensions in your field-book. Proceed in like manner with each angle and side; and if you find all the angles right angles, and all the sides equal, the figure is a square.

*To compute the content.*

**RULE.**—Multiply the side into itself, and the product will be the area, in square links. Cut off five places, as decimals, toward the right hand of the product, and those on the left will express the number of acres.

Reduce these decimals into roods and perches, by multiplying them successively by 4 and by 40, and cutting off five figures on the right as before, in each product.

If the dimensions be in yards, divide the square of the side by 4840, and the quotient will be acres.

Reduce the remainder, if any, into roods and perches, by multiplying it successively by 4 and by 40, as before.

**NOTE 1.**—Any person who is not in possession of a chain may take the dimensions in yards; or, where accuracy is not required, by pacing.

2. In measuring with the chain, it is best to set down the number of links, as 956: where, instead of reading 956 links, read 9 chains and 56 links.

3. The dimensions of small parcels of land, sold by the square yard, for building, &c., should be taken in feet and inches with a measuring-tape. Paving, digging, &c., should be measured in the same manner.

4. In computing the contents of fields, it is customary, among practical surveyors, to call the remainder a perch, if it exceeds half a one; but if it be less than half a perch, it is considered as nothing.

5. The learner should carefully *work over* and *put down* all the solutions given in this book, in order that he may better understand the different methods of calculation.

*Examples.*

1. What is the area in acres of the square ABCD, whose side is 956 links?

$$\begin{array}{r}
 956 \\
 956 \\
 \hline
 5736 \\
 4780 \\
 8604 \\
 \hline
 913936 \\
 4 \\
 \hline
 \cdot 55744 \\
 40 \\
 \hline
 22\cdot 29760
 \end{array}$$

22·29760 Area 9a. 0r. 22p.

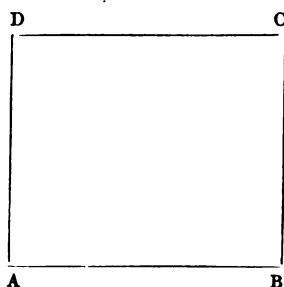



2. Required the area in acres of the square whose side is 264 yards.

$$\begin{array}{r}
 264 \\
 \underline{264} \\
 1056 \\
 1584 \\
 \underline{528} \\
 4840)69696(14a. \\
 \underline{4840} \\
 21296 \\
 \underline{19360} \\
 \cdot 1936 \\
 \underline{\phantom{0}4} \\
 4840)7744(1r. \\
 \underline{4840} \\
 2904 \\
 \underline{\phantom{0}40} \\
 484,0)11616,0(24p. \\
 \underline{968} \\
 \cdot 1936 \\
 \underline{1936} \text{ Area } 14a. \text{ } 1r. \text{ } 24p.
 \end{array}$$

3. If the side of a square be 1567 links, what is its area in acres?

*Ans.* 24a. 2r. 9p.

4. If the side of a square be 263 yards, what is its area in acres?

*Ans.* 14a. 1r. 6p.

## PROBLEM II.

### *Rectangular Fields.*

When you enter a field which has the appearance of a rectangle, try each angle, and measure each side, as before; and if you find all the angles right-angles, and the opposite sides equal, the figure is a rectangle.

*To compute the content.*

**RULE.**—Multiply the length by the breadth, and the product will be the area.

*Examples.*

1. What is the area of the rectangle ABCD, whose length AB is 1235 links, and breadth AD, 557 links?

$$\begin{array}{r}
 1235 \\
 \underline{557} \\
 8645 \\
 6175 \\
 6175 \\
 \underline{687895} \\
 \phantom{68789}4 \\
 \underline{\phantom{68789}40} \\
 \underline{\underline{2063200}}
 \end{array}$$

*Area 6a. 3r. 21p.*

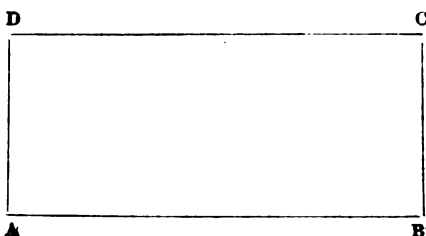

2. Required the area of a rectangle, whose length is 235 and breadth 162 yards.

$$\begin{array}{r}
 235 \\
 \underline{162} \\
 470 \\
 1410 \\
 \underline{235} \\
 484,0)3807,0(7a. \\
 \underline{3388} \\
 419 \\
 \underline{4} \\
 484)1676(3r. \\
 \underline{1452} \\
 224 \\
 \underline{40} \\
 484)8960(18p. \\
 \underline{484} \\
 4120 \\
 \underline{3872} \\
 \underline{\underline{248}}
 \end{array}$$

*Ans. 7a. 3r. 18p.*

3. The length of a rectangular field is 1225 links, and its breadth 613 links; required the plan and area.

*Area 7a. 2r. 1p.*

C

4. If the length of a rectangle be 135, and breadth 50 yards ; what is its area ?  
*Ans. 1a. 1r. 23p.*

NOTE.—As squares and rectangles seldom occur in surveying, it is more advisable to treat every field of four sides as a trapezium. (See Problem IV.)

### PROBLEM III.

#### *Triangular Fields.*

When you have to survey a field in the form of a triangle, set up a pole at each corner, when there are no natural marks. Then measure along the base till you come to the point where you think a perpendicular will fall from the opposite angle. There plant your cross, and turn its index till the mark at each end of the base can be seen through one of the grooves. Then apply your eye to the other groove, and if you see the mark at the opposite angle, you are in the right place to measure the perpendicular ; if not, move the instrument backward or forward along the line, till you can see the three marks as above directed. Enter in your field-book the distance from the end of the base to the cross, and the length of the perpendicular. Then measure the remainder of the base.

NOTE 1.—Be especially careful that, in measuring the two parts of the base and the perpendicular, no confusion of arrows takes place.

2. In ranging perpendiculars by the cross, you must always proceed as above directed.

#### *Construction.*

Having the place of the perpendicular, the figure may be easily constructed, as follows. From any scale of equal parts, lay off the base ; erect the perpendicular at its proper point ; draw a line from each end of the base to the end of the perpendicular, and the figure will be completed.

NOTE.—Having the diagonal, the two perpendiculars, and the place of each perpendicular given, you may construct any trapezium in the same manner.

#### *To compute the Content.*

RULE.—Multiply the base and perpendicular together, divide the product by 2, and the quotient will be the area.

Or, multiply half the base by the whole perpendicular, or the whole base by half the perpendicular, and the product will be the area.

#### *Examples.*

1. It is required to survey the triangular field ABC, and to find its area.

Measure from A toward c, and when you come to *m*, for instance at 935 links, try with your cross; and if this be the point for the perpendicular, measure *mB* = 625 links. Return and measure *mC* = 628 links, making the whole base = 1563 links; then construct the figure, and find its area.

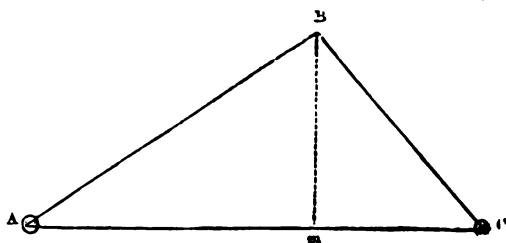

$$\begin{array}{r}
 1563 \text{ base.} \\
 625 \text{ per.} \\
 \hline
 7815 \\
 3126 \\
 9378 \\
 2)976875 \\
 \underline{488437} \\
 4 \\
 353748 \\
 40 \\
 \hline
 2149920 \text{ Area } 4a. 3r. 21p.
 \end{array}$$

2. The distance between the beginning of the base and the place of the perpendicular is 125, the perpendicular 82, and the whole base 318 yards; what is the area of the triangle?

$$\begin{array}{r}
 318 \text{ base.} \\
 82 \text{ per.} \\
 \hline
 636 \\
 2544 \\
 2)26076 \\
 4840)13038(2a. \\
 \underline{9680} \\
 3358 \\
 4 \\
 4840)13432(2r. \\
 \underline{9680} \\
 3752 \\
 40 \\
 484,0)15008,0(31p. \\
 \underline{1452} \\
 488 \\
 484 \\
 \hline
 4 \text{ Ans. } 2a. 2r. 31p.
 \end{array}$$

3. Measuring along the base of a triangle 862 links, I found the true place of the perpendicular, and the perpendicular itself = 995 links ; the remainder of the base measured 1110 links ; what is the area of the triangle ?  
*Ans. 9a. 3r. 10p.*

4. Measuring along the base of a triangle field, I found the perpendicular to range at 865, and its length 645 links ; the remainder of the base measured 569 links ; required the plan and area.

*Area 4a. 2r. 20p.*

NOTE.—If the examples in this problem, or any of the following problems, be thought too few, more may easily be supplied by the teacher sketching fields, at pleasure, with his pen, which the learner may measure by a scale. This method will be found very advantageous ; as it will give the learner a good idea in what manner he must run his lines, take his dimensions, and enter his notes, when he commences field-practice.

### PROBLEM IV.

*Fields in the form of a Trapezium.*

A quadrilateral field, having unequal sides, may be surveyed by measuring a diagonal. This divides it into two triangles, to each of which it serves as a base.

*To compute the Content.*

RULE.—Multiply the sum of the two perpendiculars by the diagonal, divide the product by 2, and the quotient will be the area.

NOTE 1.—Always make choice of the longer diagonal, because the longer the base line of a triangle, the more obtuse is its subtending angle ; and, consequently, there is the less chance to mistake, as the perpendicular will be shorter, and its place more easily and more accurately determined. After finishing the surveying, if you choose, measure the other diagonal, which will enable you to prove your work. (See Problems I. and II., Part IV.)

2. If a field be very long, or elevated in the middle, so that you cannot see from one end to the other, it may be divided into two or more trapeziums ; or you may range your lines over the hill, as directed in Part V.

3. When two perpendiculars cannot be taken upon either of the diagonals, such fields must be divided into two triangles by measuring a diagonal for the base of one triangle, and one side of the field for the base of the other. (See Example 6.)

4. Sometimes surveyors affect to reduce trapeziums into squares, or rectangles, by measuring all the sides, adding each two opposite sides together, and taking half their sum respectively for a mean length and breadth ; but this method leads to very erroneous results. (See Part IV., Prob. II.)

*Examples.*

1. It is required to survey the trapezium ABCD, and find its area.

Measure from A toward C. Finding the perpendicular  $ab$  to rise at 473, and its length 437 links; return, and continue toward C,

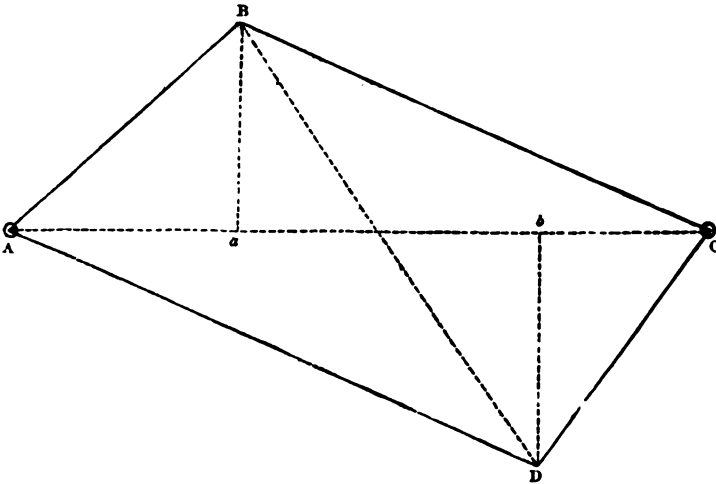

till you come to the place where the second perpendicular  $bD$  rises. There note down its distance from A, 1128 links; measure  $bD = 508$  links; then complete the measuring of the diagonal to C, and let the whole be 1490 links.

After this, measure the diagonal BD, for a proof-line, which you will find 1152 links.

$$\begin{array}{r}
 437 \quad \left. \vphantom{437} \right\} \text{per.} \\
 508 \quad \left. \vphantom{508} \right\} \\
 \hline
 945 \quad \text{sum} \\
 1490 \quad \text{diag.} \\
 \hline
 85050 \\
 3780 \\
 945 \\
 \hline
 2)1408050 \\
 \underline{704025} \\
 4 \\
 \hline
 016100 \\
 40 \\
 \hline
 644000 \quad \text{Area 7a. Or. 6p.} \\
 \hline
 \hline
 \end{array}$$

2. In taking the dimensions of a trapezium, I found the first perpendicular to rise at 539, and to measure 725 links; the second at

1890, and to measure 832 links ; the whole diagonal measured 2456 links ; required the area of the trapezium. *Ans.* 19a. 0r. 19p.

3. The first perpendicular of a trapezium rises at 467, and measures 545 links ; the second at 1418, and measures 467 links ; required its area, the whole diagonal being 1840 links. *Ans.* 9a. 1r. 9p.

4. Lay down a field, and find its area, from the following notes.

	AD	
	1625	
	1252	523 c
B 639	636	
Begin	at A	range W.
Per. on the left	base	per on the right
	line or	
	diag.	

*Area* 9a. 1r. 30½p.

5. Required the plan and area of a field, from the following dimensions.

	AD	diag.
	1744	
c 545	1365	
	546	652 B
Begin	at A	range E.

*Area* 10a. 1r. 30p.

6. Lay down a field, and find its area, from the following notes.

	DB	diag.
	1095	
	488	298 c
	L. off D	
	AD	side
	1358	
B 532	410	
Begin	at A	range E.

*Answer.*

Double areas

722456 triangle ABD

326310 triangle BCD

Whole area 5a. 0r. 39p.

#### ANOTHER METHOD.

A field of four sides may sometimes be surveyed by dividing it into two right-angled triangles, and a trapezoid.

*To compute the Content.*

**RULE.**—Multiply the sum of the two perpendiculars by their distance upon the base-line, and the product will be double the area of the trapezoid. The area of each triangle must be found as before.

*Examples.*

1. It is required to survey the annexed figure, and find its area.

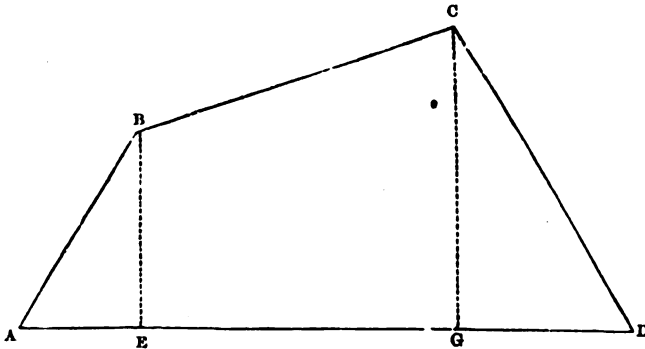

Measure the base AD, and enter in your field-book where the two perpendiculars rise, &c., as in the following notes.

GC = 645	AD = 1326
EB = 422	AG = 952
Per.	Base

Triangle ABE  
 422 per.  
 265 base  
 2110  
 2532  
 844  
111830

Triangle GCD  
 645 per.  
 374 base  
 2580  
 4515  
 1935  
241230

Trapezoid EBCG  
 422 } per.  
 645 }  
 1067 sum  
 687 base  
 7469  
 8536  
 6402  
733029



$$\begin{array}{r}
 733029 \\
 241230 \\
 111830 \\
 \hline
 2)1086089 \\
 \underline{543044} \\
 4 \\
 \hline
 172176 \\
 40 \\
 \hline
 \underline{\underline{2887040}} \quad \text{Area 5a. 1r. 29p.}
 \end{array}$$

2. Required the plan and area of a field, from the following notes.

	AB 1681	
E	1015	564 D
G	432	705 C
Begin	at A	range W.
Per. on the left	base	per. on the right

*Area 7a. Or. 16p.*

3. Lay down a field, and find its area, from the following dimensions.

	AB 1546	
D 625	1146	E
C 883	564	G
Begin	at A	range E.

*Area 8a. Or. 20½p.*

### PROBLEM V.

*Fields comprehended under more than Four Straight Sides.*

Fields having more than four sides may be surveyed by reducing them into triangles and trapeziums.

Thus, a field of five sides may be reduced into a triangle and a trapezium; of six, into two trapeziums; of seven, into two trapeziums and a triangle; of eight, into three trapeziums; &c.

The propriety of dividing fields in this manner depends entirely on the relation which the angles have to one another; it is, therefore, sometimes more accurate to divide them into triangles.

*To compute the Content.*

**RULE.**—By the rules given in the last two problems, find the double area of each triangle and trapezium contained in the figure.

Collect all the double areas into one sum, which divide by 2, and the quotient will be the whole area.

*Examples.*

1. Lay down a field, and find its area, from the following notes.

	CE	
	1666	diag.
	1326	496 A
	1000	
D 376	573	
	R off C	
	AC	
	1433	diag.
	1000	
B 273	643	
Begin	at A	range W.
Per. on the left	diag.	per. on the right

*Construction.*

From the notes, the figure obviously consists of five sides, and is divided into a triangle and a trapezium. Draw the base AC, which

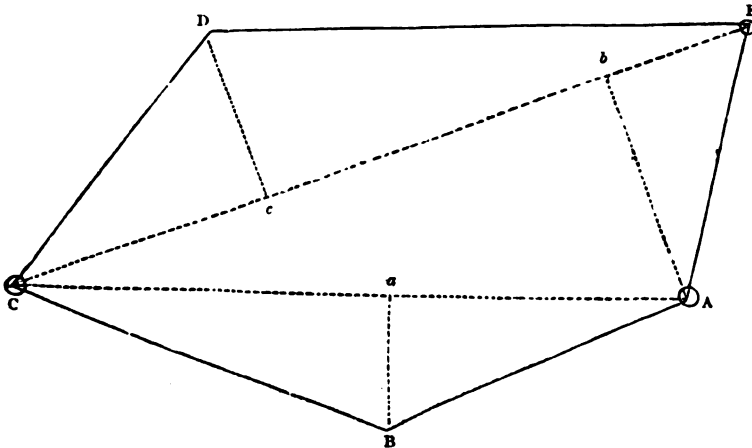

make = 1433 links; at 643 links, let fall the perpendicular  $ab$ , upon which lay off 273 links; join  $AB$  and  $CB$ , and the triangle is

completed. Then, with A as a centre, and 496 links in your compasses as a radius, describe an arc; and with C as a centre, and 1326 as a radius, describe another arc, intersecting the former in *b*.—Through *b* draw the diagonal CE = 1666 links; upon which, at 573 links, erect the perpendicular *cd* = 376 links. Join CD, DE, and EA, and the figure will be completed.

NOTE.—If the learner fully comprehend the above construction, he will not find it difficult to lay down the figures belonging to the following examples; as the same process will succeed in them and all similar cases.

Triangle ABC 1433 base 273 per. <hr style="width: 50%; margin-left: 0;"/> 4299 10031 2866 <hr style="width: 50%; margin-left: 0;"/> 391209	Trapezium ACDE 376 } 496 } per. <hr style="width: 50%; margin-left: 0;"/> 872 sum 1666 diag. <hr style="width: 50%; margin-left: 0;"/> 5232 5232 872 <hr style="width: 50%; margin-left: 0;"/> 1452752
--	--

391209	}	double areas
1452752	}	collected
<hr style="width: 50%; margin-left: 0;"/>		
2)1843961		
9·21980		
4		
<hr style="width: 50%; margin-left: 0;"/>		
·87920		
40		
<hr style="width: 50%; margin-left: 0;"/>		
35·16800		<i>Area 9a. Or. 35p.</i>

2. Lay down a field, and find its area, from the following dimensions.

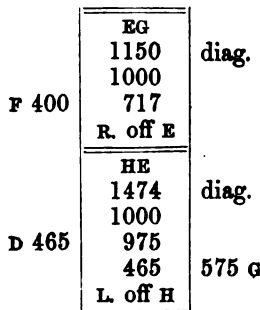

	CH	
	1635	diag.
	1000	
D 235	910	390 I
	575	
	R. off C	
	AC	
	1165	diag.
	1000	
B 263	530	
	400	630 I
Begin	at A	range E.S.E.

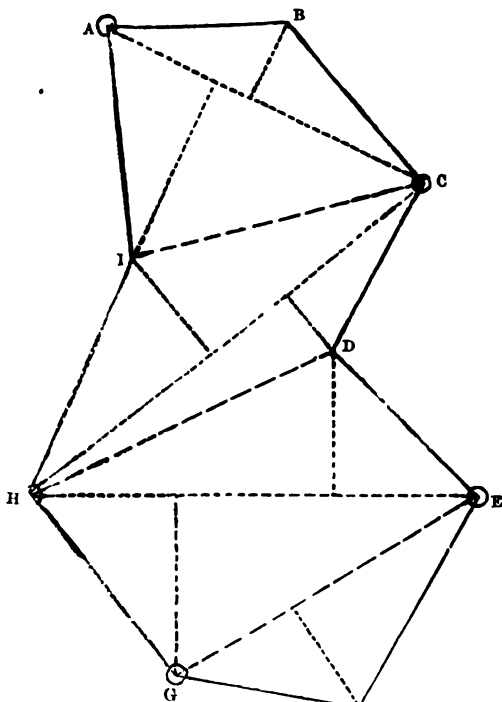

Trapezium ABCI
630 } per.
263 } per.
<u>893</u> sum
1165 diag.
<u>4465</u>
5358
893
893
<u>1040345</u>

Trapezium CDHI
235 } per.
390 } per.
<u>625</u> sum
1635 diag.
<u>3125</u>
1875
3750
625
<u>1021875</u>

Trapezium DEGH

575	}	per.
465		
<hr style="width: 100%;"/>		
1040	sum	
1474	diag.	
4160		
7280		
4160		
1040		
<hr style="width: 100%;"/>		
1532960		
<hr style="width: 100%;"/>		

Triangle EFG

1150	base
400	per.
<hr style="width: 100%;"/>	
460000	
<hr style="width: 100%;"/>	

1040345	}	double areas collected
1021875		
1532960		
460000		
<hr style="width: 100%;"/>		
2)4055180		
20·27590		
4		
<hr style="width: 100%;"/>		
1·10360		
40		
<hr style="width: 100%;"/>		
4·14400	<i>Area 20a. 1r. 4p.</i>	
<hr style="width: 100%;"/>		

3. Required the plan and area of a field, from the following dimensions.

E 195	BA	diag.
Return	1008	
	466	
	to B	
	<hr style="width: 100%;"/>	
	AD	diag.
C 415	1345	
	944	
Begin	855	536 B range W.
	at A	

*Answer.*

Double areas

1279095 trapezium ABDC

196560 triangle AEB

Whole area 7a. 1r. 20½p.

4. Lay down a field, and find its area, from the following notes.

E 581	DF	diag.
	1940	
	1040	
	825	
	R. off D	362 B
	<hr style="width: 100%;"/>	
	AD	diag.
C 322	1488	
	772	
	606	
Begin	at A	665 B range W.

*Answer.*

Double areas  
 1468656 trapezium ABDC  
 1829420 trapezium DEFB  
*Whole area 16a. 1r. 38p.*

5. Draw the plan of a field, and find its area, from the following dimensions.

	HK	diag.
	1285	
I 382	740	
	600	162 G
	R. off H	
	-----	
	FH	diag.
	1223	
E 661	803	
	666	276 G
	L. off F	
	-----	
	DF	diag.
	1716	
	1080	246 B
E 409	761	
	R. off D	
	-----	
	AD	diag.
	1547	
C 603	1023	
	525	488 B
Begin	at A	range W.

*Answer.*

Double areas  
 1687777 trapezium ABDC  
 1123980 trapezium DEFB  
 1145951 trapezium FGHE  
 699040 trapezium HGKI  
*Whole area 23a. 1r. 5p.*

ANOTHER METHOD.

A field consisting of five, six, seven, or more sides, may sometimes be surveyed by measuring one diagonal, and upon it erecting perpendiculars to all the opposite angles, on each side. This process will divide the whole field into right-angled triangles, and trapezoids, the areas of which must be found as before.

*Examples.*

1. Lay down a field, and find its area, from the following notes.

	AF	
	1896	diag.
E 259	1342	
	1132	325 D
	1000	
C 367	763	
B 756	522	
Begin	at A	range E.

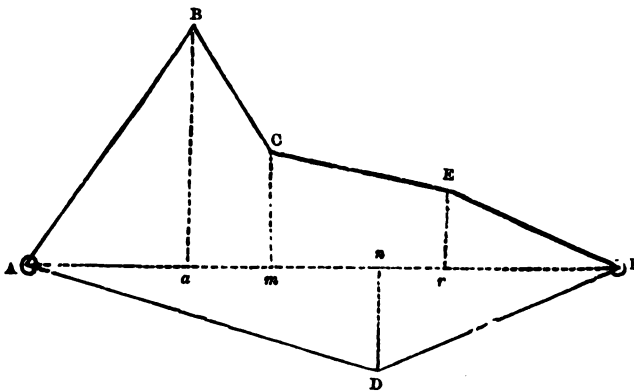

Triangle  $ABa$   
 756 per.  
 522 base  
1512  
 1512  
 3780  
394632

Trapezoid  $aBCm$   
 756 } per.  
 367 }  
1123 sum  
 241 base  
1123  
 4492  
 2246  
270643

Trapezoid  $mCEr$   
 367 } per.  
 259 }  
626 sum  
 579 base  
5634  
 4382  
 3130  
362454

Triangle  $rEF$   
 554 base  
 259 per.  
4986  
 2770  
 1108  
143486

Triangle ADF	394632	}	double areas collected.
1896 base	270643		
325 per.	362454		
9480	143486		
3792	616200		
5688	2)1787415		
<u>616200</u>	<u>8·93707</u>		
	4		
	<u>3·74828</u>		
	40		
	<u>29·93120</u>		

*Area 8a. 3r. 30p.*

2. Lay down a field, and find its area, from the following dimensions.

	AK	diag.
0	1700	0
I 290	1465	<i>d</i>
<i>w</i>	1368	365 H
<i>r</i>	1055	381 G
F 144	986	<i>n</i>
<i>m</i>	794	218 E
<i>e</i>	515	350 D
C 250	444	<i>c</i>
<i>a</i>	150	275 B
0	000	0
Begin	at A	range W.

*Answer.*

Triangles and Trapezoids on the Right.

- Double areas
- 41250 triangle *ABa*
- 228125 trapezoid *aBDe*
- 158472 trapezoid *eDEm*
- 156339 trapezoid *mEGr*
- 233498 trapezoid *rGHw*
- 121180 triangle *wHK*
- 938864 sum



## Triangles and Trapezoids on the Left.

Double areas
111000 triangle ACC
213548 trapezoid cCFn
207886 trapezoid nFId
68150 triangle dIK
<u>600584</u> sum
938864 sum brought forward
<u>1539448</u> sum total

*Whole area 7a. 2r. 31½p.*

3. It is required to lay down a field and find its area, from the following notes.

	AL	diag.
M 460	2150	0
<i>d</i>	1670	295 K
I 395	1530	<i>w</i>
<i>r</i>	1345	160 H
G 670	1275	<i>n</i>
F 400	880	<i>m</i>
<i>e</i>	780	270 E
<i>c</i>	465	150 D
C 405	305	<i>a</i>
0	000	300 B
Begin	at A	range E.

*Answer.*

## Triangles and Trapezoids on the Right.

Double areas
209250 trapezoid ABDC
132300 trapezoid cDEe
242950 trapezoid eEhr
147875 trapezoid rHKd
141600 triangle dKL
<u>873975</u> sum

## Triangles and Trapezoids on the Left.

Double areas
123525 triangle Acc
462875 trapezoid aCFm
422650 trapezoid mFGn
271575 trapezoid nGIw
530100 trapezoid wIML
<u>1810725</u> sum
873975 sum brought down
<u>2684700</u> sum total

*Whole area 13a. 1r. 27¾p.*

## PROBLEM VI.

*Fields comprehended under any Number of Crooked or Curved Sides.*

When a field is bounded by crooked fences, measure a line as near to each as the angles or curves will permit; in doing which, take an offset to each corner or angle in the fence. Where the fences are curved, those offsets must be so taken that a right line drawn from the end of any one perpendicular to the end of the next, on each side, would neither exclude any part of the land to be measured, nor include any of that which is adjacent. Perpendiculars thus erected will divide the whole offset into right-angled triangles and trapezoids, the areas of which are found as before.

**NOTE 1.**—If the curves be so large that many of the offsets would be 2, 3, 4, or 5 chains long, it will be more expeditious and accurate to measure the base without taking any offsets, except such as are short, leaving stations in proper places along the base, to which, when you have obtained its length, you may return, and from them run fresh station-lines to some convenient point, or points, in the curved fence. Upon these lines take offsets as before. (See Example 3.)

2. If any of the fences be curved inward, it is frequently most convenient to measure a line on the outside of the field, and upon it erect perpendiculars to the curved fence, which, in this case, are called insets; and the area thus included must be subtracted from the area of the whole figure. (See Example 4.)

3. When the fences and ditches are to be measured with the field to which they belong, it is generally most practicable to fix the stations within the fences, at a little distance from the corners, and then to measure to the roots of the quickwood, adding or subtracting 5 or 6 links, according to the custom of the place, for the breadth of the ditch. (See Example 5.)

4. When the offsets are small, their places on the base line may be determined by laying the offset staff at right angles upon the chain; but when large, and accuracy is required, they must be found by the cross, and measured by the chain.

5. The base of each triangle and trapezoid, forming an offset, may be found by subtracting the distances on the chain line from each other.

6. The following three methods of finding the area of offsets are erroneous. Some divide the sum of the offsets by their number, for a mean breadth; others divide that sum by one more than their number, for a mean breadth; and both multiply the whole base by the mean breadth, thus supposed to be found, for the area of the whole offset. The first of these methods generally gives the area too much; and the second sometimes too much and sometimes too little. A third method, which is usually more accurate than either of the preceding ones, is to set down each offset twice (accounting that one where the boundary meets the station-line) except the first and last, which are only entered once. The sum of these offsets is then multiplied by the base, the product divided by the number of offsets set down, and the quotient given as the area required.

7. Directions for laying down offsets by a plotting-scale may be seen in Part II.

D

*Examples.*

1. Lay down the figure of a right-line offset, and find its area, from the following notes :—

	AB	
<i>n</i> 200	1569	
<i>m</i> 210	1249	
	1000	
<i>i</i> 70	952	
<i>e</i> 50	745	
<i>c</i> 159	450	
<i>a</i> 120	265	
	0	
Begin at	A	range E.

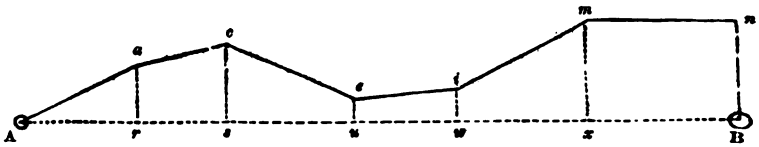

## BY THE TRUE METHOD.

Triangle <i>Ara</i>
265 base
120 per.
<u>5300</u>
265
<u>31800</u>

Trapezoid <i>racs</i>
120 } per.
159 } per.
<u>279 sum</u>
185 base
<u>1395</u>
2232
279
<u>51615</u>

Trapezoid <i>scsu</i>
159 } per.
50 } per.
<u>209 sum</u>
295 base
<u>1045</u>
1881
418
<u>61655</u>

Trapezoid <i>uisu</i>
50 } per.
70 } per.
<u>120 sum</u>
207 base
<u>840</u>
240
<u>24840</u>

Trapezoid <i>wina</i>	Trapezoid <i>ammb</i>
70 } par.	210 } per.
<u>210</u> }	<u>200</u> }
280 sum	410 sum
297 base	320 base
<u>1960</u>	<u>8200</u>
2520	123
560	<u>131200</u>
<u>83160</u>	

31800	}	double areas collected
51615		
61655		
24840		
83160		
<u>131200</u>		
2)384270		
1·92135		
4		
<u>3·68540</u>		
40		
<u>27·41600</u>		

Hence the true area is *1a. 3r. 27p.*

BY THE FIRST FALSE METHOD.

120	1569 length
159	134·8 breadth
50	<u>12552</u>
70	6276
210	4707
200	1569
6) 809	<u>2·115012</u>
<u>134·8 mean breadth</u>	4
	·460048
	40
	<u>18·401920</u>

Here the area appears to be *2a. 0r. 18p.*, which is too much by *31p.*

## BY THE SECOND FALSE METHOD.

120	1569 length
159	<u>115.5 breadth</u>
50	7845
70	7845
210	1569
<u>200</u>	<u>1569</u>
7) 809	1.812195
<u>115.5 mean breadth</u>	<u>4</u>
	3.248780
	40
	<u>9.951200</u>

Here the area appears to be 1a. 3r. 1p., which is too little by 17p.

## BY THE THIRD FALSE METHOD.

0	1569 length
120	<u>1418 sum</u>
120	12552
159	1569
159	6276
50	<u>1569</u>
50	12) 22.24842
70	<u>1.85403</u>
70	4
210	<u>3.41612</u>
210	40
<u>200</u>	<u>16.64480</u>
<u>1418 sum</u>	

Here the area appears to be 1a. 3r. 16p., which is too little by 11p.

2. Lay down a curve-line offset, and find its area, from the following notes.

AB	
1012	0
892	53
786	80
645	95
500	45
350	63
200	84
100	52
000	0
A	range W.

Begin at

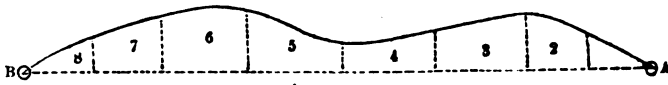

52	
<u>100</u>	
5200 No. 1	
52	
<u>84</u>	
136	
<u>100</u>	
<u>13600 No. 2</u>	

63
<u>45</u>
108
<u>150</u>
5400
<u>108</u>
<u>16200 No. 4</u>

95
<u>80</u>
175
<u>141</u>
175
<u>700</u>
175
<u>24675 No. 6</u>

84
<u>63</u>
147
<u>150</u>
7350
<u>147</u>
<u>22050 No. 3</u>

45
<u>95</u>
140
<u>145</u>
700
<u>56</u>
14
<u>20300 No. 5</u>

80
<u>53</u>
133
<u>106</u>
798
<u>133</u>
<u>14098 No. 7</u>

53
<u>120</u>
1060
<u>53</u>
<u>6360 No. 8</u>

5200	}	double areas collected
13600		
22050		
16200		
20300		
24675		
14098		
<u>6360</u>		
2)122483		
<u>61241</u>		
4		
<u>244964</u>		
40		
<u>1798560</u>		

1798560 Area 2r. 18p.

**NOTE.**—When the content of a small piece of land does not amount to an acre, and if the number of figures in the area be under five, as many ciphers must be placed on the left of the area as will make it five before we can *point-off* the decimals, because 100,000 square links make an acre. Suppose the area to be 9625 square links; then we must make it .09625; and by multiplying successively by 4 and 40, we shall obtain for the area 15.4 square perches.

3. Lay down the figure of a piece of land adjoining a river, and find its area, from the following notes.

	EB		
	1350		
	1265	140	a
	1200	170	
	1100	244	
	1000	250	
	900	190	
	800	100	
	700	0	
	600	0	
	500	94	River
	400	142	
	300	153	
	200	70	
	000	0	
Left off E	and go	SW. to B	
	CE		
	1060	0	
	1000	50	
	900	110	
	800	154	
	700	173	
	600	142	
	400	0	
	200	0	
	70	82	m
	000	0	
Return	to C, and go	NW. to E	River 100 links in breadth
	AD		
0	2463		
70	2300		
m 110	2200	C	
	2000		
E 698	1410		
	1000		
a 165	250	B	
60	100		
0	000		
Begin	at A	range E.	

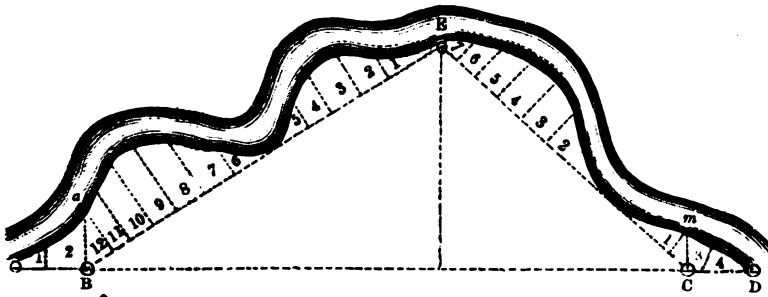

Triangle BCE

1950 base

698 per.

15600

1755

1170

1361100

Offsets taken on the line AD

60	60	110
<u>100</u>	<u>165</u>	<u>70</u>
6000 No. 1	225	<u>180</u>
	150	100
6000 No. 1	<u>11250</u>	<u>18000</u> No. 3
33750 „ 2	225	
18000 „ 3	<u>33750</u> No. 2	163
11410 „ 4		<u>70</u>
<u>69160</u> sum		<u>11410</u> No. 4

Offsets taken on the line CE

82	142	142
<u>200</u>	<u>200</u>	<u>173</u>
16400 No. 1	28400 No. 2	315
		100
173	154	<u>31500</u> No. 3
<u>154</u>	<u>110</u>	
327	264	
100	100	
<u>32700</u> No. 4	<u>26400</u> No. 5	110
		<u>50</u>
16400 No. 1		<u>160</u>
28400 „ 2	60	100
31500 „ 3	<u>50</u>	<u>16000</u> No. 6
32700 „ 4	<u>3000</u> No. 7	
26400 „ 5		
16000 „ 6		
3000 „ 7		
<u>154400</u> sum		



## Offsets taken on the line EB

70	190	14000 No. 1
<u>200</u>	<u>250</u>	22300 „ 2
<u>14000</u> No. 1	<u>440</u>	29500 „ 3
	100	23600 „ 4
70	<u>44000</u> No. 8	9400 „ 5
<u>153</u>		10000 „ 6
<u>223</u>	250	29000 „ 7
100	<u>244</u>	44000 „ 8
<u>22300</u> No. 2	<u>494</u>	49400 „ 9
	100	41400 „ 10
153	<u>49400</u> No. 9	20150 „ 11
<u>142</u>		<u>11900</u> „ 12
<u>295</u>	244	<u>304650</u> sum
100	<u>170</u>	
<u>29500</u> No. 3	<u>414</u>	
	100	
142	<u>41400</u> No. 10	
<u>94</u>		
236	170	1361100 } whole
100	140	69160 } double
<u>23600</u> No. 4	<u>310</u>	154400 } areas
	65	304650 } collected
94	<u>1550</u>	2)1889310
<u>100</u>	186	<u>944655</u>
<u>9400</u> No. 5	<u>20150</u> No. 11	4
		<u>178620</u>
100	85	40
<u>100</u>	<u>140</u>	<u>3144800</u>
<u>10000</u> No. 6	<u>3400</u>	
	85	
100	<u>11900</u> No. 12	
<u>190</u>		
<u>290</u>		
100		
<u>29000</u> No. 7		

Area 9a. 1r. 31p.

4. Lay down a field, and find its area, from the following notes.

Ca	
525	perpen.
R. off C	
BC	
846	0
600	64
400	85
200	50
000	0
R. off B	
AB	
1253	
1000	
586	$\alpha$ , the place of the perpen.
A	range W.

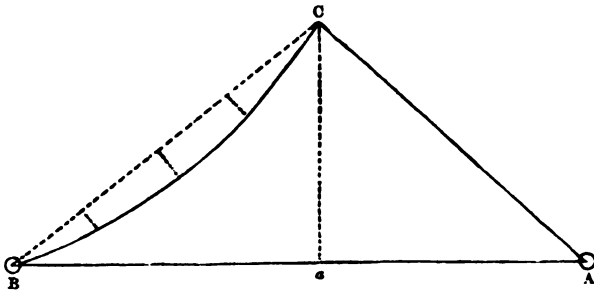

Triangle ABC

1253 base

525 per.

6265

2506

6265

657825

Insets taken on the line BC

50

200

10000

50

85

135

200

27000

85

64

149

200

29800

246

64

984

1476

15744

10000

27000

29800

15744

82544

} double areas collected

$$\begin{array}{r}
 657825 \text{ triangle ABC} \\
 82544 \text{ insets} \\
 2) \overline{575281} \text{ difference} \\
 \underline{287640} \\
 4 \\
 \hline
 350560 \\
 40 \\
 \hline
 2022400 \text{ Area 2a. 3r. 20p.}
 \end{array}$$

5. Draw a plan of a field, and find its area, from the following notes.

	AC	diag.
	1155	
	1000	
495	915	
	360	520
From	A go	N.W.
To	the	fence
48	660	
53	630	to A
40	500	
25	380	
50	200	
62	000	
From	D go	S.
To	the	fence
40	1012	
42	950	to D
54	600	
33	400	
12	260	
30	150	
65	000	
From	C go	E.
To	the	fence
25	615	
35	550	to C
30	400	
10	240	
22	150	
45	000	
From	B go	N.
To	the	fence
33	1090	
45	1045	to B
56	800	
40	500	
48	300	
30	000	
Begin at	A and	go W.

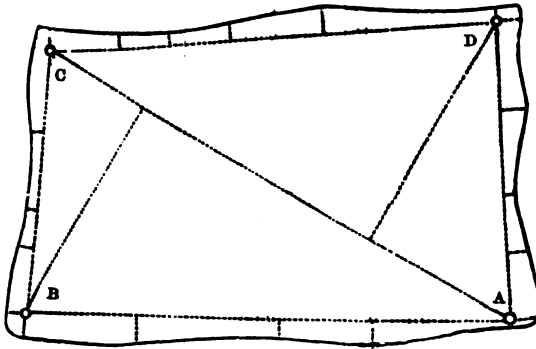

*Answer.*

Double areas		
1172325	trapezium ABCD	
98055	AB	}
32980	BC	
81254	CD	
58820	DA	
		offsets taken on the different lines

*Whole area 7a. Or. 34 $\frac{1}{2}$ p.*

6. Lay down a field, and find its area, from the following dimensions.

EB	
442	0
345	74
256	25
115	56
000	0
L. off E	
CE	
387	0
296	43
200	59
100	36
000	0
L. off C	
AC	
1294	diag.
1050	
1000	
290	485 D
R off A	

B 530

	DA	
0	567	
32	458	
67	364	
24	235	
43	123	
0	000	
	R. off D	
	CD	
	1116	
	1000	
129	465	
80 + 30	310	
65	200	
42	100	
0	000	
	R. off C	
	BC	
	584	diag.
E 293	328	
	R. off B	
	AB	
0	1173	
37	1000	
44	900	
78	750	
46	600	
85	400	
42	200	
0	000	
Begin at	A	range W.

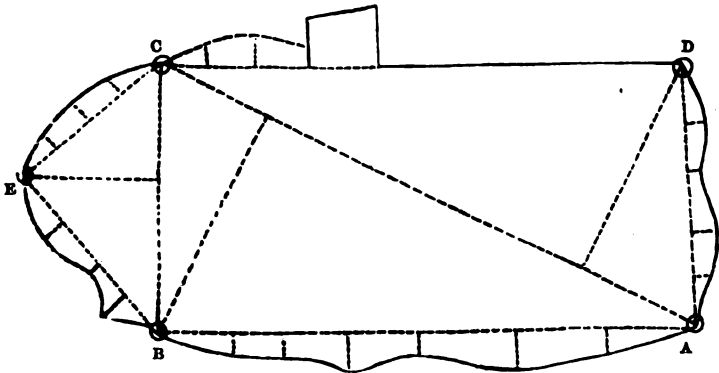

*Answer.*

Double areas  
 1313410 trapezium ABCD  
 171112 triangle BEC  
 111401 } AB  
 62395 } CD } offsets taken  
 37326 } DA } on the  
 26805 } CE } different lines  
 33850 } EB }

*Whole area 8a. 3r. 5p.*

7. It is required to lay down a field, and find its area, from the following notes.

To	the	fence
80	1121	
100	1025	to A
83	930	
70	800	
100	700	
130	600	
190	500	
140	400	
70	300	
50	200	
40	100	
0	000	
	R. off D	
	BD	diag.
	1900	
	1300	823 A
	1000	
c 780	440	
	R. off B	
	AB	
0	1530	
66	1350	
73	1200	
85	1100	
94	1000	
73	900	
40	780	
70	630	
110	467	
76	300	
70	200	
69	100	
96	000	
Begin	at A	and go W.

*Answer.*

Double areas

3045700 trapezium ABCD

218592 offsets taken on the line AB

205555 ditto on the line DA

*Whole area 17a. 1r. 15p.*

8. Required the area and plan of a field, from the following dimensions.

	AD	
	1080	0
	1000	40
	950	60
	890	54
	820	38
	740	12
	650	10
	580	35
	535	60
	480	75
	420	65
	300	35
	220	30
	100	60
	50	70
	000	50
	L. off A	
	CA	
	1170	diag.
	920	540 B
D 525	225	
	R. off C	
	BC	
0	1065	
25	1005	
35	946	
50	870	
40	830	
90	780	
115	715	
110	650	
80	625	
75	510	
55	440	
70	330	
65	250	
35	215	
48	150	
40	100	
60	50	
55	000	
	R. off B	

To	the	fence
0	700	
40	645	to B
55	570	
72	500	
68	450	
49	375	
42	300	
37	225	
53	170	
40	130	
50	50	to A
52	000	
From the	fence	go N.

*Answer.*

Double areas

1246050 trapezium ABCD

67710 offsets taken on the line AB

129820 ditto on the line BC

91210 ditto on the line AD

*Whole area 7a. 2r. 27 $\frac{3}{4}$ p.*

9. Lay down a field, and find its area, from the following notes.

	EA	
0	500	
18	450	
40	400	
74	350	
108	300	
104	250	
80	200	
35	100	
20	50	
0	000	
	R. off E	
	DE	
0	590	
20	550	
50	500	
130	450	
152	400	
110	350	
94	300	
110	250	
105	200	
80	150	
50	100	
25	50	
0	000	
Return	to	D



	AC	
B 550	1220	diag.
	915	
	700	524 D
	R. off A	
	DA	
E 322	875	diag.
	490	
	R. off D	
	CD	
0	750	
34	700	
55	650	
70	600	
84	550	
90	500	
95	450	
100	400	
75	350	
38	320	
44	200	
40	100	
30	50	
0	000	
	R. off C	
	BC	
0	640	
18	600	
25	550	
30	500	
25	450	
35	430	
65	350	
60	320	
40	250	
10	140	
20	100	
40	000	
	R. off B	
To	the	fence
65	1115	
70	1075	to B
60	1000	
55	920	
60	868	
40	800	
20	750	
28	700	
65	600	
80	550	

73	400	
70	300	
34	200	
40	134	
23	100	
0	000	
Begin	at A	range W.

*Answer.*

Double areas

1310280 trapezium ABCD

281750 triangle AED

116056	AB	}	offsets taken on the different lines
41020	BC		
83180	CD		
92400	DE		
53650	EA		

*Whole area 9a. 3r. 22½p.*

### PROBLEM VII.

#### *Narrow Pieces of Land.*

A method frequently adopted, in surveying narrow pieces of land, is to take breadths in different places, add all these breadths together, and divide their sum by their number, for a mean breadth; and this supposed mean breadth is multiplied by the length, for the area: but, as the method of finding the mean breadth is liable to mistake, this process may lead to very erroneous results.

If, for example, a piece of land taper regularly from one end to the other, you may take its breadth at each end; half the sum of these breadths will then be its mean breadth; so that you may multiply this mean breadth by the length, for the area. But if it be irregular, you must take breadths in the widest and narrowest places, or at every particular curve, noting the place of each breadth upon the chain-line. These breadths will divide it into triangles and trapezoids, which compute as before.

**NOTE 1.**—The breadths must be taken directly across the land to be measured, and therefore, if considerable, will require the use of the cross.

**2.** If a piece of land be curved, or longer on one side than on the other, by measuring along the middle you will obtain the true or mean length.

**3.** When several pieces of land, of various lengths, are contiguous to each other, it will generally be most expeditious to measure only one base-line, noting the point where each piece begins and ends, perpendicularly to the line. In this case,

E

be especially careful that no confusion take place in noting down the breadths of the respective pieces.

4. Paring, reaping, &c., both in this and the foregoing problems, should be surveyed with a slack chain, in order to obtain the measurement of the surface.

5. It is best to take the first and last breadths of lands or ridges about half a chain from each end, and account them as the end-breadths; because, in turning, the plough usually makes some of them appear either broader or narrower than they are in reality. It may also be observed, that it is frequently necessary to take the breadths to half a link; for when the length is great, half a link in the breadth is too considerable to be neglected.

6. If a narrow piece of land be very irregular, you may obtain its area most accurately by measuring a base-line, in a convenient position; and upon it erecting perpendiculars to the boundaries, on each side.

7. In surveying with the chain and cross, when the area only of any field or piece of ground is required, it is unnecessary to lay down the figure.

*Examples.*

1. Find the area of a tapering piece of land, whose length is 2562 links, and breadth at one end 126, and at the other 232 links.

$$\begin{array}{r}
 126 \\
 232 \\
 \hline
 2)358 \text{ sum} \\
 \hline
 179 \text{ mean} \\
 2562 \text{ length} \\
 \hline
 358 \\
 1074 \\
 895 \\
 358 \\
 \hline
 4\cdot58598 \\
 4 \\
 \hline
 2\cdot34392 \\
 40 \\
 \hline
 13\cdot75680 \text{ Area 4a. 2r. 14p.}
 \end{array}$$

2. Find the area of a piece of land, which is broadest towards the middle, from the following dimensions.

BY THE TRUE METHOD.

2322	169
2000	
1056	215
1000	
000	125
base.	per.

$$\begin{array}{r}
 125 \\
 215 \\
 \hline
 340 \text{ sum} \\
 1056 \text{ base} \\
 \hline
 2040 \\
 170 \\
 34 \\
 \hline
 359040
 \end{array}
 \quad
 \begin{array}{r}
 215 \\
 169 \\
 \hline
 384 \text{ sum} \\
 1266 \text{ base} \\
 \hline
 2304 \\
 2304 \\
 768 \\
 384 \\
 \hline
 486144
 \end{array}$$

$$\begin{array}{r}
 359040 \} \text{ double areas} \\
 486144 \} \text{ collected} \\
 \hline
 2) 845184 \\
 \hline
 4 \cdot 22592 \\
 \hline
 4 \\
 \hline
 \cdot 90368 \\
 \hline
 40 \\
 \hline
 \underline{\underline{36 \cdot 14720}} \text{ Area, 4a. Or. 36p.}
 \end{array}$$

BY THE FALSE METHOD.

125	}	breadths	2322 length
215			169·6 breadth
169			13932
3)509			20898
<u>169·6 mean</u>			13932
			2322
			<u>3·938112</u>
			4
			<u>3·752448</u>
			40
			<u><u>30·097920</u></u>

Here the area appears to be 3a. 3r. 30p., which is too little by 1r. 6p.

Again, the dimensions remaining as before, suppose the piece to be narrowest towards the middle ; the area by the false method will be the same as already found.

BY THE TRUE METHOD.

2322	169
2000	
1056	125
1000	
000	215
base.	per.

$$\begin{array}{r}
 215 \} \text{ per.} \\
 125 \} \\
 \hline
 340 \text{ sum} \\
 1056 \text{ base} \\
 \hline
 2040 \\
 170 \\
 \hline
 34 \\
 \hline
 \underline{\underline{359040}}
 \end{array}$$

$$\begin{array}{r}
 125 \} \text{ per.} \\
 169 \} \\
 \hline
 294 \text{ sum} \\
 1266 \text{ base} \\
 \hline
 1764 \\
 1764 \\
 \hline
 588 \\
 \hline
 294 \\
 \hline
 \underline{\underline{372204}}
 \end{array}$$

$$\begin{array}{r}
 359040 \} \text{ double areas} \\
 372204 \} \text{ collected} \\
 \hline
 2) 731244 \\
 \hline
 3\cdot65622 \\
 \hline
 4 \\
 \hline
 2\cdot62488 \\
 \hline
 40 \\
 \hline
 \underline{\underline{24\cdot99520}}
 \end{array}$$

The true area is *3a. 2r. 25p.*; hence the false area is too much by *1r. 5p.*

Lastly, the dimensions still continuing, suppose the breadth towards the middle to be greater than that at one end, and less than at the other; the false area will still be the same.

## BY THE TRUE METHOD.

2322	125
2000	
1056	169
1000	
000	215
base.	per.

$$\begin{array}{r}
 215 \} \text{ per.} \\
 169 \} \\
 \hline
 384 \text{ sum} \\
 1056 \text{ base} \\
 \hline
 2304 \\
 1920 \\
 \hline
 384 \\
 \hline
 \underline{\underline{405504}}
 \end{array}
 \qquad
 \begin{array}{r}
 169 \} \text{ per.} \\
 125 \} \\
 \hline
 294 \text{ sum} \\
 1266 \text{ base} \\
 \hline
 1764 \\
 1764 \\
 \hline
 588 \\
 \hline
 294 \\
 \hline
 \underline{\underline{372204}}
 \end{array}$$

$$\begin{array}{r}
 405504 \} \text{ double areas} \\
 372204 \} \text{ collected} \\
 \hline
 2) 777708 \\
 \hline
 3\cdot88854 \\
 \hline
 4 \\
 \hline
 3\cdot55416 \\
 \hline
 40 \\
 \hline
 \underline{\underline{22\cdot16640}}
 \end{array}$$

The true area is *3a. 3r. 22p.*; hence the false area is too much by *8p.*

3. Draw a plan of an irregular piece of land, and find its area from the following dimensions.

	AB	
0	1325	136
246	1015	
	987	58
	790	134
318	718	
	560	162
223	465	
	345	125
346	266	
372	000	246
From	A go	E.

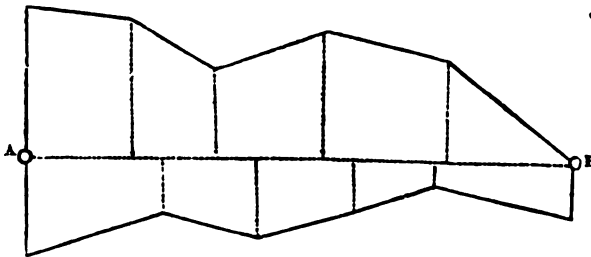

*Answer.*

Double areas  
 361176 offsets on the right  
 684860 ditto on the left  
 2)1046036 sum  
 5·23018=5a. Or. 36½p. the area required.

4. Find the area of five lands, from the following dimensions.

2378	185
2000	190
1700	194
1400	198
1000	200
700	195
400	189
000	185

*Area 4a. 2r. 13½p.*

5. Required the area of six lands, from the following notes.

3422	189
3000	
2500	204
2000	
1800	226
1000	
800	191
000	165

*Area 6a. 3r. 12p.*

6. Find the area of seven lands, from the following dimensions.

NOTE.—In calculating the area, the half-links must be treated as decimals.

2900	99½
2600	98½
2300	101
2000	97½
1900	100½
1600	102
1300	99½
1000	101½
900	100
600	98
300	100½
000	100½

*Area 2a. 3r. 23½p.*

7. It is required to lay down a narrow piece of land, and find its area, from the following dimensions.

	AB	
250	1230	460
	1050	250
60	1000	
	918	300
25	800	
	690	235
0	500	
	440	108
0	300	
	100	216
153	000	130
From	A go	N.

*Answer.*

Double areas

552890 offsets on the right

140800 ditto on the left

Whole area 3a. 1r. 35p.

8. Lay down a field, and find its area, from the following notes.

	BC	
0	521	
70	400	
97	300	
99	200	
78	100	
0	000	
	R. off B	
	AB	
0	1235	521 to c
57	1100	430
114	900	323
177	650	245
207	500	219
232	350	240
252	200	275
268	000	360
From	A go	N.

*Answer.*

Double areas

763685 offsets on the right of AB

414695 do. on the left of AB

70270 do. on the line BC

*Area 6a. Or. 38 $\frac{3}{4}$ p.*

### PROBLEM VIII.

*Meres and Woods.*

When you have a mere or wood to survey, by the help of your cross, fix four marks on its outside, in such a manner as to form a rectangle or square. Then measure each side of the rectangle or square, taking insets to the edge of the mere or wood, the area of which insets must be treated as directed in Note 2, Problem VI.

If the opposite sides be not found equal, or very nearly so, your marks do not form four right angles; in which case you must rectify your error.

NOTE 1.—It is a more expeditious method to measure the four sides of a quadrilateral figure, having one right angle, paying no regard to the length of the sides. Then construct the figure by Part I. Problem XIV., and draw the longer diagonal, upon which let fall a perpendicular from each of the opposite angles. This diagonal and these perpendiculars you must measure by the scale used in plotting.

2. It sometimes happens that the mere or wood is of a triangular form; in this



case, the work may be very readily done by measuring the three sides of a triangle, taking insets as before. After which construct the triangle, and from the opposite angle let fall a perpendicular upon the base, and proceed as before.

3. By this problem you may measure fields into which you are not permitted to enter, or which contain obstructions.

*Examples.*

1. Let the following figure represent a mere ; its area is required.

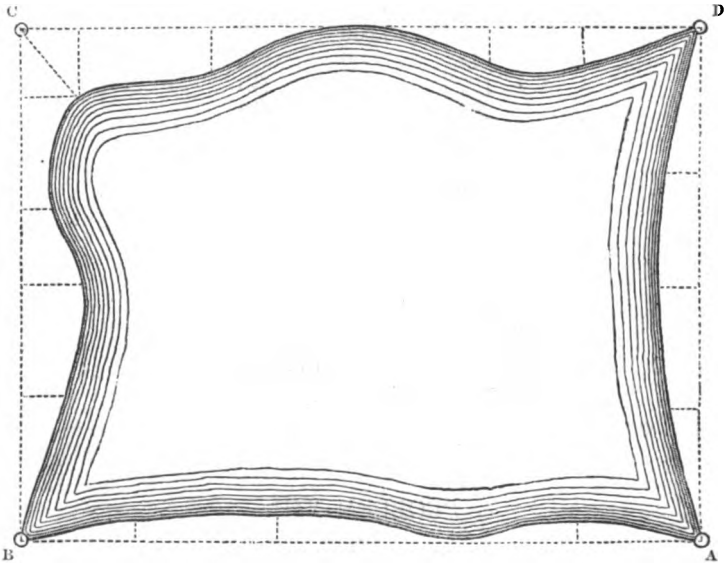

Having fixed four marks, A, B, C, and D, forming a rectangle ; begin at A, and measure the line AB, taking the necessary insets, and entering them in your field-book. In the same manner proceed with the other three sides ; and you will find noted the following dimensions.

DA	
1100	0
1000	
800	50
550	70
300	60
000	0
R. off D	

CD	
1450	0
1200	70
1000	80
820	0
600	0
400	95
110	150
000	0
R. off C	
BC	
1100	0
950	110
700	70
550	142
300	100
000	0
R. off B	
AB	
1450	0
1200	55
1000	
900	75
550	32
250	65
000	0
Begin at A	range W.

*Answer.*

1595000 area of the rectangle ABCD

135550	} AB	} double areas of the insets taken on the different lines	
183800			
168450			} CD
95500			

2)583300

291650 area of the whole insets

13·03350 ditto of the mere

4  
 13400  
 40

5·36000 Area 13a. Or. 5p.

2. Let the following figure represent a wood ; its area is required.

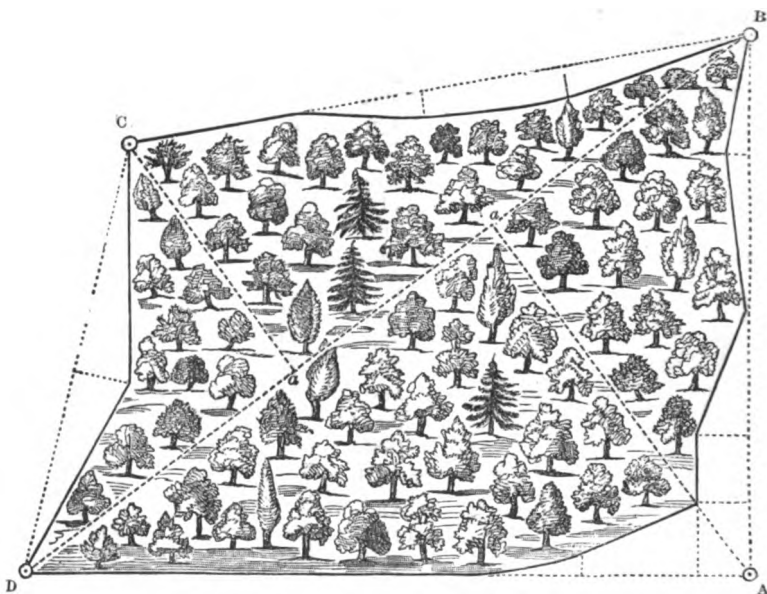

Set up your cross at A, and let your assistant fix the marks B and D, so that the angle at A may be a right angle; and measure the line AB, taking insets as before. Then fix the mark C, as most convenient; measure the other three lines, and you will find in your field-book the following notes.

	DA
0	1550
160	1440
50	1200
	1000
0	900
	L. off D
	CD
0	950
120	500
0	000
	L. off C
	BC
	1340
0	1050
	1000
50	700
60	400
0	000
	L. off B

	AB	
0	1150	
	1000	
50	900	
0	550	
100	300	
110	160	
0	000	
Begin at	A	range N.

*Answer.*

Having constructed the figure, you will find the diagonal BD to measure 1930, the perpendicular A a 923, and C a 605 links.

Double areas

2949040 trapezium ABCD

102000	} AB	}	insets taken on the different lines
74500	} BC		
114000	} CD		
83000	} DA		

373500 whole insets

2575540 wood.

*Area 12a. 3r. 20p.*

PROBLEM IX.

*To find the Area of a Segment of a Circle, or any other Curvilinear Figure, by means of Equidistant Ordinates.*

RULE.—If a right line AN be divided into any even number of equal parts AC, CE, EG, &c.; and at the points of division be erected perpendicular ordinates AB, CD, EF, &c., terminated by any curve BDF, &c.; and if A be put for the sum of the extreme or first and last ordinates, AB, NO; B for the sum of the even ordinates, CD, GH, LM, &c., viz., the second, fourth, sixth, &c.; and C for the sum of all the rest, EF, IK, &c., viz., the third, fifth, &c., or the odd ordinates, wanting the first and last; then the common distance AC, or CE, &c., of the ordinates, being multiplied by the sum arising from the addition of A, four times B, and two times C; one-third of the product will be the area ABON, very nearly; that is,  $\frac{A + 4B + 2C}{3} \times D =$  the area, putting D = AC, the common distance of the ordinates.

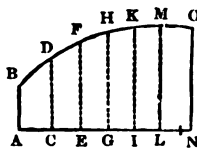

**NOTE.**—The foregoing rule being expressed in an algebraic form, is seldom properly understood by learners; but the following one may be easily comprehended and committed to memory.

**RULE.**—To the sum of the first and last ordinates, add four times the sum of all the even ordinates, and twice the sum of all the odd ordinates, not including the first and last; multiply this sum by the common distance of the ordinates, divide the product by 3, and the quotient will be the area required.

**NOTE.**—The length of the base must be ascertained before you begin to take the ordinates, in order that you may divide it into an even number of equal parts; or you may take the dimensions without doing this, and find the areas of the pieces at the end, by the rules for triangles and trapezoids, which being added to that part of the figure computed by equidistant ordinates, will give the whole area. See the following Examples.

*Examples.*

1. Required the plan and area of a piece of land, measured by equidistant ordinates, from the following notes.

AB	0
1167	44 EF
1100	97 CD
1000	139
900	175
800	206
700	230
600	248
500	260
400	264
300	268
200	262
100	252
000	

Begin at A and go W.

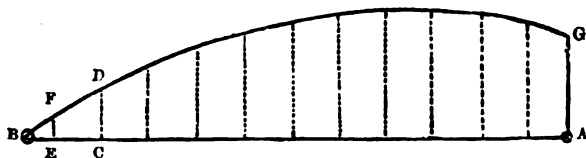

The first and last ordinates  
 252 the first ordinate AG  
 97 the last ordinate CD  
349 sum

The even ordinates  
 262 second  
 264 fourth  
 248 sixth  
 206 eighth  
139 tenth  
 1119 sum  
 4  
4476 four times the sum

The odd ordinates  
 268 third  
 260 fifth  
 230 seventh  
175 ninth  
 933 sum  
 2  
1866 twice the sum

349 the first and last ordinates  
 4476 four times the sum, &c.  
1866 twice the sum, &c.  
 6691 sum total  
 100 the common distance  
3)669100  
223033 the area of the figure ACDG

Trapezoid CEFD  
 97  
 44  
141  
 100  
14100

Triangle EBF  
 67  
 44  
268  
 268  
2948

Double areas	
14100	trapezoid <i>CEFD</i>
2948	triangle <i>KBF</i>
<hr/>	
2)17048	sum
8524	the area of the figure <i>CBD</i>
223033	ditto of the figure <i>ACDG</i>
<hr/>	
2·31557	sum
4	
<hr/>	
1·26228	
40	
<hr/>	
10·49120	
<hr/>	

Hence the area of the whole figure *ACEBFDGA* is  $2a. 1r. 10\frac{1}{2}p.$  nearly.

2. Lay down a piece of ground, and find its area from the following equidistant ordinates.

	AB	
0	1000	0
85	900	75
150	800	125
200	700	160
230	600	180
247	500	185
250	400	177
240	300	157
216	200	125
180	100	73
130	000	0
Begin	at A and	go E.

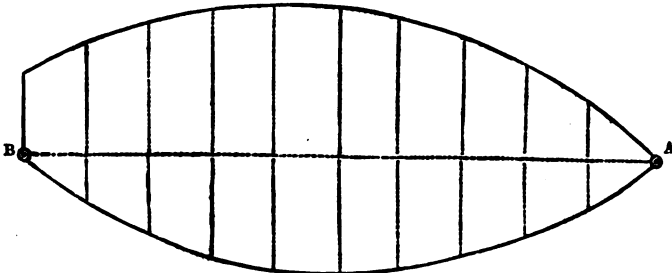

The first and last ordinates  
 130 the first ordinate  
 000 the last ditto  
130 sum

The even ordinates  
 180 + 73 = 253 second  
 240 + 157 = 397 fourth  
 247 + 185 = 432 sixth  
 200 + 160 = 360 eighth  
 85 + 75 = 160 tenth  
1602 sum  
4  
6408 four times the sum

The odd ordinates  
 216 + 125 = 341 third  
 250 + 177 = 427 fifth  
 230 + 180 = 410 seventh  
 150 + 125 = 275 ninth  
1453 sum  
2  
2906 twice the sum

130 the first and last ordinates  
 6408 four times the sum, &c.  
 2906 twice the sum, &c.  
9444 sum total  
 100 the common distance  
 3)944400  
 3·14800 area in square links  
4  
 ·59200  
40  
23·68000 Area 3a. Or. 23½p.

3. Required the plan and area of a piece of ground, from the following equidistant ordinates.



	AB	
220	1200	
234	1100	
245	1000	
250	900	
246	800	
235	700	
221	600	
200	500	
176	400	
140	300	
100	200	
55	100	
0	000	
Begin	at A	range E.

*Answer.*

220 the first and last ordinates

4456 four times the sum, &c.

1976 twice the sum, &c.

6652 sum total

100 the common distance

3)665200

2-21733 area in square links

4

.86932

40

34-77280 Area 2a. Or. 34 $\frac{1}{2}$ p.

4. Find the area of 4 lands, measured by equidistant ordinates, from the following notes.

182	1290	70
183	1200	101
178	1100	115
189	1000	112
190	900	96
187	800	98
179	700	95
150	600	100
182	500	120
185	400	110
180	300	131
160	200	133
170	100	137
188	000	130

*Answer.*

602	the first and last ordinates
7092	four times the sum, &c.
2848	twice the sum, &c.
<u>10542</u>	sum total
100	the common distance
3)1054200	
351400	
24120	trapezoid at the end
<u>375520</u>	area in square links
4	
<u>302080</u>	
40	
<u>0.83200</u>	<i>Area 3a. 3r. 0<math>\frac{3}{4}</math>p.</i>

5. Find the area of 6 lands, by equidistant ordinates, from the following dimensions.

147	3090
153	3000
152	2700
150	2400
149	2100
147	1800
144	1500
142	1200
143	900
148	600
146	300
145	000

*Answer.*

298	the first and last ordinates
2936	four times the sum, &c.
1174	twice the sum, &c.
<u>4408</u>	sum total
300	the common distance
3)1322400	
440800	
13500	trapezoid at the end
<u>454300</u>	area in square links
4	
<u>217200</u>	
40	
<u>6.88000</u>	<i>Area 4a. 2r. 6<math>\frac{3}{4}</math>p.</i>

6. Required the plan and area of a piece of ground from the following equidistant ordinates.

	AB	
236	1200	180
170	1100	220
126	1000	246
90	900	265
67	800	270
55	700	269
57	600	260
66	500	243
87	400	215
120	300	180
170	200	134
232	100	65
327	000	0
Begin	at A and	go W.

*Answer.*

743 the first and last ordinates

7900 four times the sum, &c.

3264 twice the sum, &c.

11907 sum total

100 the common distance

3)1190700

3·96900 area in square links

4

3·87600

40

35·04000 Area 3a. 3r. 35p.

7. Required the plan and area of a field from the following equidistant ordinates.

	AB	
217	1096	202
187	1000	150
150	900	112
125	800	84
107	700	66
98	600	58
95	500	57
100	400	65
114	300	80
130	200	110
167	100	148
190	000	200
Begin	at A and	go N.

*Answer.*

$$\begin{array}{r}
 727 \text{ the first and last ordinates} \\
 4384 \text{ four times the sum, \&c.} \\
 1540 \text{ twice the sum, \&c.} \\
 \hline
 6651 \text{ sum total} \\
 100 \text{ the common distance} \\
 \hline
 3)665100 \\
 \hline
 221700 \\
 36288 \text{ trapezoid at the end} \\
 \hline
 2\cdot57988 \text{ area in square links} \\
 4 \\
 \hline
 2\cdot31952 \\
 40 \\
 \hline
 12\cdot78080 \text{ Area } 2a. 2r. 12\frac{3}{4}p.
 \end{array}$$

**NOTE.**—Whenever the rule given in this Problem can be applied, it will be found more easy, expeditious, and accurate, in finding the areas of offsets and of narrow pieces of land, than the rules for triangles and trapezoids.

### PROBLEM X.

*To find the Breadth of a River.*

#### EXAMPLE.

Let the following figure represent a river, the breadth of which is required.

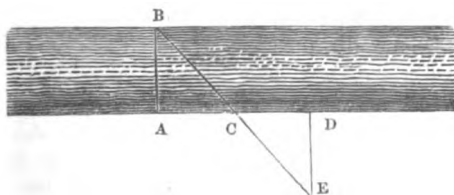

Fix upon any object B, close by the edge of the river, on the side opposite to which you stand. By the help of your cross, make AD perpendicular to AB; also make AC = CD, and erect the perpendicular DE; and when you have arrived at the point E, in a direct line with CB, the distance DE will be = AB, the breadth of the river; for by Theo. 1, Part I, the angle ACB = DCE, and as AC = CD, and the angles A and D are right angles, it is evident that the triangles ABC and CDE are not only similar but equal.

NOTE 1.—The distance between A and the edge of the river must be deduced from DE, when it is not convenient to fix A close by the river's edge.

2. This Problem may also be well applied in measuring the distance of an inaccessible object; for let AC equal 8, CD equal 2, and DE equal 10 chains; then, by similar triangles, as  $CD : DE :: AC : AB$ ; that is, as  $2 : 10 :: 8 : 40$  chains = AB. (See Theo. 11, Part I.)

### PROBLEM XI.

*Lines upon which there are Impediments not obstructing Sight.*

Suppose  $mn$  to represent a deep pit or water, and A and B two objects, the direct distance of which is required.

At the verge of the impediment, having fixed the mark  $m$ , in a right line with A and B, measure from A to  $m$ ; and at  $m$ , by the help of your cross, erect the perpendicular  $ma$ , which measure to the outside of the interposed obstruction, as at  $c$ . Then on the other side, as at  $n$ , in a line with A and B, erect the perpendicular  $ne$ ; and make  $nb$  equal to  $mc$ .

Measure  $bc$ , which will be equal to  $mn$ ; and from  $n$  measure the distance  $nB$ ; then  $bc$  added to  $Am$  and  $nB$  will give the whole distance AB.

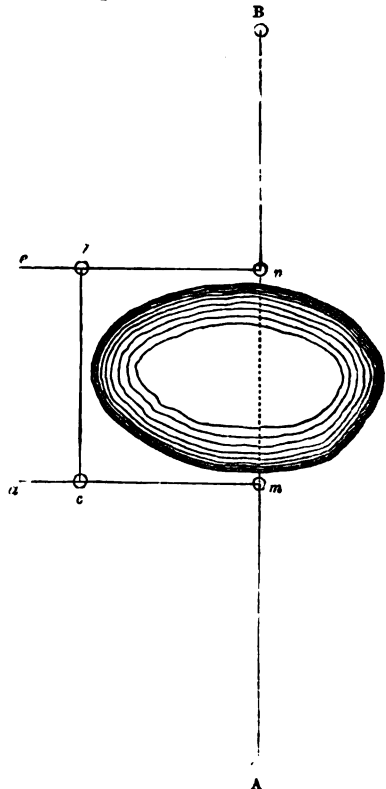

## PROBLEM XII.

*Lines upon which there are Impediments obstructing Sight.*

## EXAMPLE.

Suppose CDEF to represent the base of a building which obstructs the sight, and through which it is necessary that a straight line should pass from an object at A to B, the direction  $AMB$  on the side A being given.

Measure from A to  $m$ ; at  $m$  erect the perpendicular  $ma$ , which measure until you are clear of the impediment, as at  $c$ .

Erect the perpendicular  $ce$ , which measure until you are beyond the building, as at  $b$ . Erect the perpendicular  $bd$ ; and make  $bn$  equal to  $mc$ , at which point you will be in a direct line with  $m$ . Erect the perpendicular  $nB$ , which measure; then  $bc$ , added to  $Am$  and  $nB$ , will give the whole distance  $AB$ .

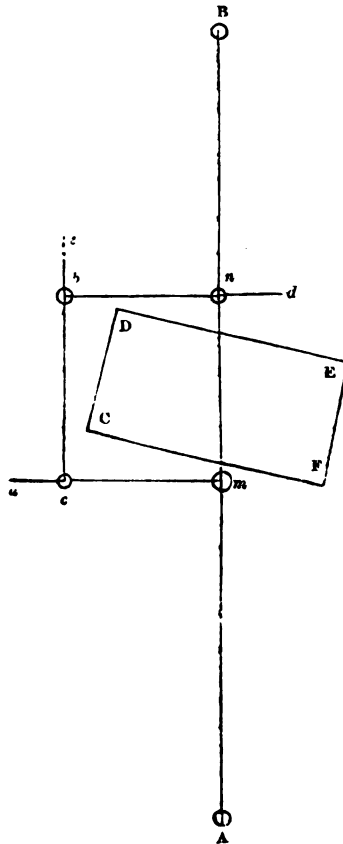

NOTE.—In the tenth and previous editions of the work the range  $Am$  was evidently understood in this problem as given, and also in Problem VII Part IV. p. 139, although not so expressed. This involves an omission; for the range or direction of a line must always be known before it can be measured. The error is now corrected in both examples. And as impediments obstructing sight are of frequent occurrence in surveying, two propositions have been added to find the line when the range  $Am$  is not given—the one with the chain, p. 89, and the other with the theodolite and chain, Part IX.

## PART IV.

THE METHOD OF SURVEYING WITH THE CHAIN ONLY; AND OF MEASURING MERES, WOODS, DISTANCES, LINES UPON WHICH THERE ARE IMPEDIMENTS, AND HILLY GROUND.

## MISCELLANEOUS INSTRUCTIONS.

THE method of surveying with the chain only is adopted by most practical surveyors, and is certainly preferable to that by the chain and cross; because it is not only as accurate, but generally more expeditious.

Whatever be the form of the field or ground to be surveyed, measure as many lines as will enable you to plot it with accuracy. The plan being drawn, you may then divide the figure into trapeziums, triangles, &c., and measure the diagonals, perpendiculars, &c., with your plotting-scale.

It is better, however, to divide small pieces and single fields into trapeziums and triangles, by measuring the diagonals and bases during the survey; so that to find the area, you will have only the perpendiculars to measure with the scale.

You should also measure, in some convenient direction, a proof-line to each trapezium and triangle.

NOTE 1.—The offsets must be treated according to the directions in Part III. Prob. VI. Or you may reduce the crooked sides to straight ones, by including as much of what does not belong to the field under your survey as you exclude of what does, in the following manner:—Apply to the crooked line in question the straight edge of a clear piece of lantern horn, so that the small parts cut off by it from the crooked figure may be equal to those which are taken in (of this equality you will presently be able to judge very correctly by a little practice); then, with a pencil, draw a line by the edge of the horn. The sides being thus successively straightened, the content may be easily found.

2. A slender bow of cane or whalebone, strung with a silk thread, may be substituted for the horn. The thread must be applied to the crooked fence, and two marks made by which to draw a straight line.

3. The sides may also be straightened by a parallel ruler; but the operation is generally tedious, and must be performed with the greatest care, or it will not be more correct than the foregoing method.

4. When the three sides of a triangle are given, the area may be found as fol-

lows : From half the sum of the three sides subtract each side severally ; multiply the half sum and the three remainders continually together, and the square root of the last product will be the area required. This method is too prolix, except in particular cases ; the operation may, however, be considerably simplified by performing the multiplication and evolution by logarithms.

PROBLEM I.

*Triangular Fields.*

When you have a triangular field to survey, begin at the most convenient corner and measure each side ; and while measuring any one of the sides, leave a mark in some situation on the chain-line, that the distance between it and the opposite angle being measured, may be a proof-line.

Or, leave marks upon any two of the chain-lines, and the distance between them will prove your work.

*Examples.*

1. It is required to construct a figure, and find its area, from the following notes.

DC 913 return to D	proof-line
CA 1029 R. off C	
BC 1275 1000 R. off B	
AB 1462 1000 800 A	

Begin at D, station for a proof-line range W.

Having constructed the figure, you will find the line DC to measure 913 links, as in the field-book ; hence, you may conclude there is no error committed in taking or setting down the dimensions.

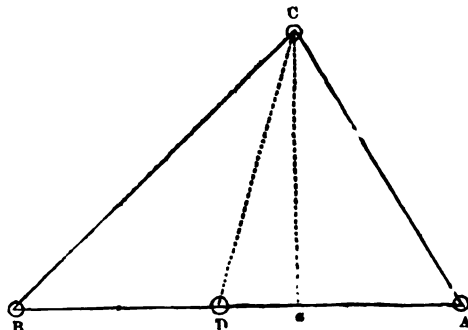



NOTE 1.—If your proof-line upon the plan does not agree, or nearly so, with that taken in the field, you may be assured that some error has been committed; you must, therefore, repeat the survey in order to discover it.

2. When land is level, and the lines are well driven, and not very long, you will generally find them to meet correctly.

*To find the Perpendicular.*

(See Part I. Prob. VI.)

Or, if you make use of a plotting-scale, lay it across the base in such a manner that any of the lines which are opposite to each other on the edges of the scale, may coincide with the base, the edge of the scale at the same time touching the opposite angle; by that edge draw a line from the base to the opposite angle; this line, or perpendicular *ca*, in the present case, you will find to be 878 links.

$$\begin{array}{r}
 1462 \text{ base} \\
 878 \text{ per.} \\
 \hline
 11696 \\
 10234 \\
 11696 \\
 \hline
 2)1283636 \\
 \underline{6\cdot41818} \\
 4 \\
 \hline
 1\cdot67272 \\
 40 \\
 \hline
 \underline{\underline{26\cdot90880}}
 \end{array}
 \quad \text{Area 6a. 1r. 27p.}$$

*Computation of the Area from the Three Sides.*

Here  $\frac{1462+1275+1029}{2} = \frac{3766}{2} = 1883$ , half the sum of the three sides. Then  $1883-1462=421$ , the first remainder;  $1883-1275=608$ , the second remainder; and  $1883-1029=854$ , the third remainder; whence  $\sqrt{1883 \times 421 \times 608 \times 854} = \sqrt{411617533376} = 641574$  square links, the area equal to 6 acres, 1 rood, and  $26\frac{1}{2}$  perches, nearly the same as before.

*The same by Logarithms.*

The log of	.	.	.	1883	.	.	.	=	3.2748503
"	.	.	.	421	.	.	.	=	2.6242821
"	.	.	.	608	.	.	.	=	2.7839036
"	.	.	.	854	.	.	.	=	2.9314579
Divide by the index of the root	.	.	.		.	.	.	2)	<u>11.6144939</u>
The quotient is the log of 641574, the area	.	.	.		.	.	.		<u>5.8072469</u>

*To find a Line between two Stations when the side of the Field is crooked, and when the Sight on the Line sought is obstructed by a Farm Homestead or other Building.*

Let ABC be the field, B and C the two stations, *e* the building on the crooked side, and BC the line sought.

From stations B and C range a parallel to the line sought, as in Problem VII., Part IV., placing a pole and making the angle *m* a right angle. Then take the inset *mB*, and measure from B to A, setting the proof-pole at D as in the preceding example; drive AC; next make the inset *nC = mB*, and the angle at *n* a right angle. If

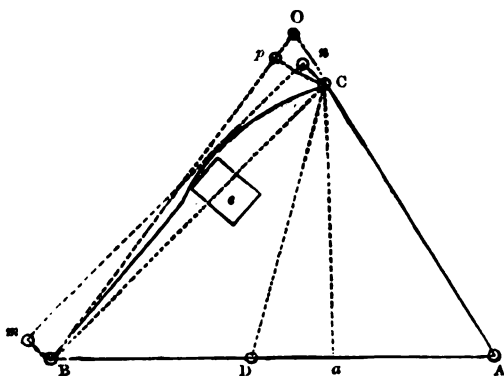

the angle *n* corresponds with the angle *m*, the line *mn* is parallel to BC. If not, correct station *n*. Measure the proof-line CD; correct station *m*; find *mn*, taking the insets and the position of the building, the areas under both having to be deducted from that of the field. Thus *mn* is found 1275 = to BC, the line sought.

Or, *Bn* may meet *AC* produced, the perpendicular *pC* forming a tie-line so as to dispense with *CD*, when *BC* would become the hypotenuse to *Bp* and *pC*, and thus be found, the base *Bp* and perpendicular *pC* having been first measured with the chain. (Theorem VII., Part I.)

2. It is required to construct a figure, and find its area, from the following notes.

	CA	
0	1252	
37	1000	
69	824	
45	716	
72	610	$m$ , station for a proof-line,
15	424	which goes to $n$ , and
55	212	measures 352 links
0	000	
	R. off C	
	BC	
0	683	
40	536	
64	354	
49	229	
0	000	
	R. off B	
	AB	
0	973	
48	745	
76	600	$n$ , station for a proof-line
56	495	
25	256	
0	000	
Begin at	A	range N.E.

*Computation of the Area by Offsets, &c.*

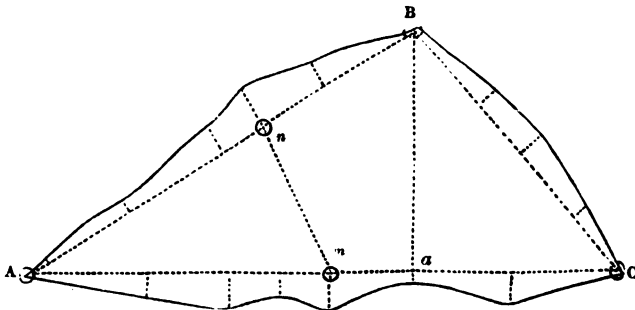

Having constructed the figure, you will find the line  $mn$  to measure 352 links, as in the field-book. You also will find the perpendicular  $ba$  to be 528 links.

Triangle ABC.  
 1252 base  
 528 per.  
10016  
 2504  
 6260  
661056

Offsets taken on the line AB.

256	56	228	
<u>25</u>	<u>76</u>	<u>48</u>	
1280	132	1824	
<u>512</u>	<u>105</u>	<u>912</u>	
<u>6400</u>	<u>660</u>	<u>10944</u>	
	132		
	<u>13860</u>	6400	} double areas collected
25		19359	
<u>56</u>		13860	
81	76	17980	
<u>239</u>	<u>48</u>	<u>10944</u>	
729	124	<u>68543</u>	sum
<u>243</u>	<u>145</u>		
162	620		
<u>19359</u>	<u>496</u>		
	124		
	<u>17980</u>		

Offsets taken on the line BC.

229	64	11221	} double areas collected
<u>49</u>	<u>40</u>	<u>14125</u>	
2061	104	18928	
<u>916</u>	<u>182</u>	<u>5880</u>	
<u>11221</u>	<u>208</u>	<u>50154</u>	
	832		
49	<u>104</u>		
<u>64</u>	<u>18928</u>		
113			
<u>125</u>	147		
565	<u>40</u>		
<u>226</u>	<u>5880</u>		
113			
<u>14125</u>			

Offsets taken on the line CA.

212	72	252	
<u>55</u>	<u>45</u>	<u>37</u>	
1060	117	1764	
<u>1060</u>	<u>106</u>	<u>756</u>	
<u>11660</u>	<u>702</u>	<u>9324</u>	
	117		
55	<u>12402</u>	11660	} double areas collected
<u>15</u>		14840	
70	45	16182	
<u>212</u>	<u>69</u>	12402	
<u>14840</u>	<u>114</u>	12312	
	108	18656	
15	<u>912</u>	<u>9324</u>	
<u>72</u>	114	<u>95376</u> sum	
87	<u>12312</u>		
<u>186</u>			
522	69		
<u>696</u>	<u>37</u>		
87	106		
<u>16182</u>	<u>176</u>		
	636		
	742		
	<u>106</u>		
	<u>18656</u>		

661056	} whole double areas collected
68543	
50154	
<u>95376</u>	
2)875129	
<u>4·37564</u>	
4	
<u>1·50256</u>	
40	
<u>20·10240</u>	Area 4a. 1r. 20p.

*Computation of the Area by reducing the Crooked Sides to Straight Ones : generally called "Casting."*

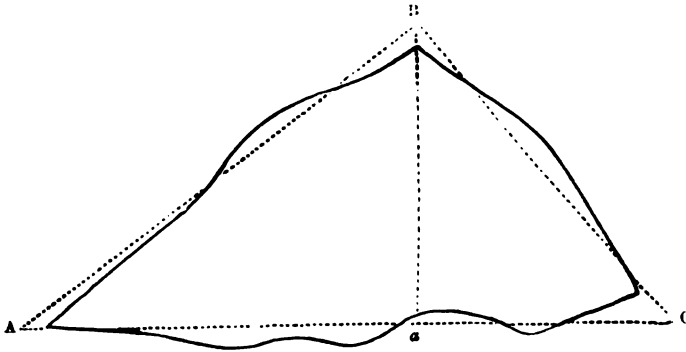

Having constructed the figure as before, and taken out the chain-lines, draw the three dotted lines AB, BC, and CA, in such a manner that the parts included may be equal to those excluded, as nearly as your eye can judge. Then the base AC being measured, will be found = 1390 links; and the perpendicular Ba = 630 links.

$$\begin{array}{r}
 1390 \text{ base} \\
 \underline{630 \text{ per.}} \\
 41700 \\
 8340 \\
 \hline
 2)875700 \\
 \underline{4\cdot37850} \\
 4 \\
 \hline
 1\cdot51400 \\
 \underline{40} \\
 \hline
 \underline{\underline{20\cdot56000}} \text{ Area } 4a. \text{ 1r. } 20p.
 \end{array}$$

NOTE.—Although the method of finding the area by casting (which depends entirely upon the accuracy of the eye) is occasionally adopted, it is certainly less correct than that by offsets, &c. A learner, therefore, ought to practise both until he can habitually come very near to the truth by the former.

3. Lay down a field, and find its area, from the following notes.

	BD 760 return to B	proof-line
	DA 1035 R. off D	
	CD	
61	1145	
55	1100	
12	1000	
72	950	
119	900	
80	850	
61	800	
59	750	
110	700	
179	600	
210	550	
215	500	
212	450	
180	400	
159	350	
142	300	
165	250	
173	200	
161	150	
126	100	
65	50	
0	000	
	R. off C	
	AC 1590	
B Begin at	890 A, and	range W.

*Answer.*

Having constructed the figure, you will find the perpendicular da, upon the base AC, to measure 740 links.

Double areas

1176600 triangle ACD

275770 offsets taken on the line CD

*Area 7a. 1r. 1 $\frac{3}{4}$ p.*

4. Lay down a field, and find its area, from the following dimensions.

	DB	
	575	proof-line
	return to D	
	CA	
	1320	
	600	D, station for a proof-line
	R. off C	
	BC	
0	880	
31	800	
73	750	
95	700	
58	600	
60	550	
95	500	
60	380	
63	250	
60	200	
45	100	
55	000	
	R. off B	
To	the	fence
30	930	
17	875	to B
48	800	
65	700	
74	600	
65	500	
58	400	
55	300	
30	200	
17	100	
0	000	
Begin	at A and	range N.E.

*Answer.*

Having constructed the figure, you will find the perpendicular *bx*, upon the base AC, to measure 573 links.

Double areas

756360 triangle ABC

85060 offsets taken on the line AB

106270 ditto on the line BC

*Area 4a. 2r. 38p.*



5. Lay down a field, and find its area, from the following notes.

	DB	
	596	proof-line
	return to D	
	CA	
0	1080	
6	1000	
50	900	
110	800	
130	700	D, station for a proof-line
145	620	
106	550	
65	500	
30	450	
16	410	
36	350	
54	300	
70	250	
74	200	
86	150	
70	100	
46	50	
0	000	
	R. off C	
	BC	
0	848	
30	800	
60	750	
80	700	
70	650	
48	600	
20	520	
46	450	
90	380	
00	330	
10	270	
70	200	
40	150	
50	100	
45	000	
	R. off B	

	To	the fence	
	50	800	
	45	755	to B
	30	700	
	40	650	
	75	600	
	130	550	
	170	500	
	156	450	
	135	400	
	50	350	
	24	300	
	66	250	
	80	200	
	40	150	
	20	100	
	23	50	
	0	000	
From		A	range N.E.

*Answer.*

Having laid down the figure, you will find the perpendicular *Ba*, upon the base *AC*, to measure 587 links.

Double areas  
 633960 triangle *ABC*  
 110800 offsets taken on the line *AB*  
 100120 ditto on the line *BC*  
 149310 ditto on the line *CA*  
*Area 4a. 3r. 35½p.*

### PROBLEM II.

*Fields in the form of a Trapezium.*

When you have a trapezium to survey, measure each side and both the diagonals, one of which will enable you to construct the figure, and the other will serve as a proof-line; or, you may measure the longer diagonal, and a proof-line in any other direction most convenient.

NOTE 1.—From various obstructions it is sometimes impossible to take either of the diagonals; in such cases measure tie lines across the angles of the field at any convenient distance (not less than two chains) from the corners. These you will find sufficient for constructing the figure, and for proofs. Or, you may take an external angle, or angles, as directed in Problem IV.

G

2. When the lines, including the angle you intend to take with the chain, are of a considerable length, it will be necessary to measure more than two chains from the angular point before you take the chord-line, because a small inaccuracy in constructing the figure, when the angular distance is short, will throw the lines, when far produced, considerably out of their true position. It sometimes happens, however, in consequence of obstructions, that it is impossible to measure the chord-line at a greater distance from the angular point than one or two chains. In such cases multiply both the chord-line and angular distance by 2, 3, 4, or any larger number, as circumstances may require, and use the products resulting in laying down the figure.

3. When the measurement of the surface is required, for reaping, &c., you must let the chain touch the sides of the lands in all places where you measure across them. If you do not measure across the lands, but along the headland, then you must add as many links to the length of the chain-line as will make it equal to one measured across the lands, parallel to and near the headland.

You may easily ascertain what number of links you ought to add by stretching the chain across the lands, and putting down an arrow at each end, after which leave hold of one of the ends, and you will observe it recede from the arrow. The number of links by which it falls short of its former position add to each chain. Some lands you will find so low that nothing need be added to the chain-line, and some will require a link to four, three, two, or even (where the lands are very high) a link or more to one chain.

When the lands are high, if the lines measured along the headlands be not lengthened, the perpendiculars will obviously measure less than they ought to do; consequently, the horizontal measure will be returned instead of the measure of the surface.

When the diagonal is measured with a slack chain it will give the measure of the surface; but in this case the perpendiculars will evidently be shorter than they would have been, if the diagonal had been measured with a tense chain; consequently, the measurement will be the same, or very nearly the same, whether the diagonal be measured with a tense or slack chain, unless the headland lines be lengthened.

4. If two or three persons measure the same piece of land separately, or even if one person measure the same piece twice over, there will generally be a difference between the measurements; this difference, however, in small pieces, should scarcely ever exceed four or five perches.

5. When land, crops of corn, &c., are bought and sold, the buyer and seller commonly choose each a surveyor, and in their measurements it occasionally happens that there exists a considerable difference. In this case the best method, perhaps, of adjusting a dispute is, that the two surveyors meet and jointly re-measure the land. If this fail, they or their employers, the buyer and seller, jointly choose an experienced surveyor, as an umpire, and abide by his decision.

### *Examples.*

1. It is required to construct a figure, and find its area from the following notes.

BD	1400	diag.
1000		
return to B		
AC	1916	diag.
1000		
R. off A		
DA	558	
R. off D		
CD	1626	
1000		
R. off C		
BC	689	
R. off B		
AB	1492	
1000		
Begin at	A	range W.

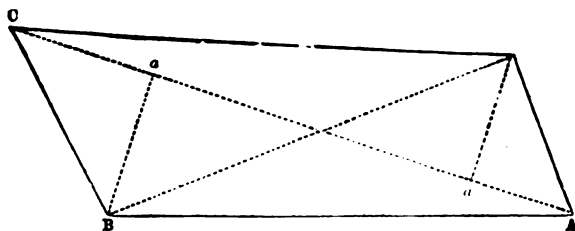

Having constructed the figure, lay your scale from B to D; and if you find it exactly 1400 links, as in the field-book, you may then measure the perpendicular  $Ba = 468$  links, and the perpendicular  $Da = 432$  links; from which you will readily compute the area required.

$$\begin{array}{r}
 468 \\
 432 \\
 \hline
 900 \text{ sum} \\
 1916 \text{ diag.} \\
 2)1724400 \\
 \underline{862200} \\
 4 \\
 \hline
 248800 \\
 40 \\
 \hline
 \underline{\underline{1952000}} \text{ Area 8a. 2r. 19p.}
 \end{array}$$

## BY THE FALSE METHOD.

*Referred to in Note 4, Part III., Prob. IV.*

$$\begin{array}{r}
 1492 = AB \\
 1626 = CD \\
 2)3118 \\
 \hline
 1559 \text{ mean length} \\
 \hline
 689 = BC \\
 558 = DA \\
 2)1247 \\
 \hline
 623 \text{ mean breadth} \\
 \hline
 \hline
 1559 \\
 623 \\
 \hline
 4677 \\
 3118 \\
 9354 \\
 971257 \\
 4 \\
 \hline
 285028 \\
 40 \\
 \hline
 \underline{\underline{3401120}}
 \end{array}$$

Here the area is found to be 9a. 2r. 34p., which is too much by 1a. 0r. 15p.; but the more nearly a trapezium approaches to a square or rectangle the less will be the error.

2. Required the area of a field from the following notes.

DB	
1365	diag.
1000	
return to D	
AC	
1288	diag.
1000	
L. of A	

DA
● 750
L. off D
CD
765
L. off C
BC
720
L. off B
AB
1600
1000
A

Begin at range E.

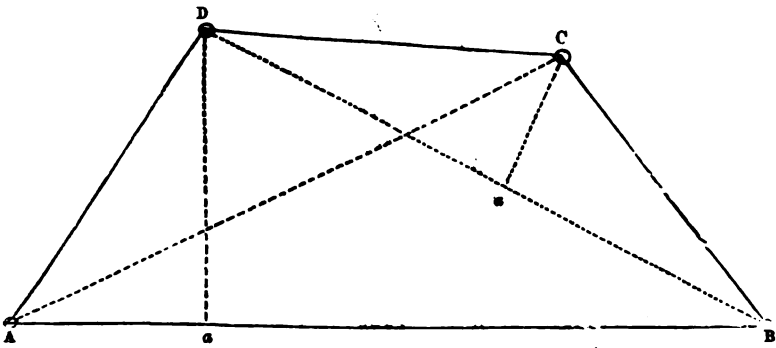

Having constructed the figure, you will find that, in consequence of the angle ADB being obtuse, a perpendicular from the angle A to the diagonal DB cannot be taken; you must, therefore, let fall the perpendicular Da from the angle D to the side AB, which you will find = 638 links. The perpendicular ca will be found = 294 links.

Triangle ABD
1600 base
638 per.
<u>12800</u>
48
96
<u><u>1020800</u></u>

Triangle BCD
1365 base
294 per.
<u>5460</u>
12285
2730
<u><u>401310</u></u>

1020800 } double areas  
 401310 } collected  
 2) 1422110  
    7-11055  
       4  
    44220  
       40  
17-68800 Area 7a. Or. 18p.

3. It is required to find the area of a field from the following notes.

	BD	
	1236	diag.
	1000	
	return to B	
	AC	
	1326	diag.
	1000	
	R. off A	
	DA	
0	515	
28	400	
50	300	
65	200	
33	100	
0	000	
	R. off D	
	CD	
0	1375	
50	1300	
75	1200	
84	1000	
52	800	
0	652	
0	356	
44	200	
50	100	
0	000	
	R. off C	
	BC	
0	664	
25	570	
0	483	
0	378	
32	300	
72	150	
85	100	
60	50	
0	000	
	R. off B	

	AB	
	946	
0	784	
50	725	
93	650	
106	600	
75	500	
32	400	
0	335	
0	242	
50	40	
0	000	
Begin at	A	range E.

BY OFFSETS, ETC.

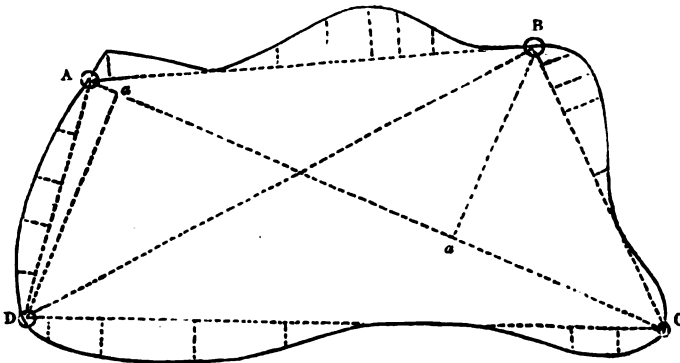

Having constructed the figure, you will find the perpendicular  $da = 512$ , and the perpendicular  $ba = 446$  links.

Trapezium ABCD	
512	} per.
446	
958	sum
1326	diag.
5748	
1916	
2874	
958	
<u>1270308</u>	



Offsets taken on the line AB

242	75	59	
<u>50</u>	106	<u>50</u>	
<u>12100</u>	<u>181</u>	<u>2950</u>	
	100		
65	<u>18100</u>	12100	} double areas collected
<u>32</u>		2080	
130	106	10700	
<u>195</u>	<u>93</u>	18100	
<u>2080</u>	<u>199</u>	9950	
	50	10725	
32	<u>9950</u>	<u>2950</u>	
<u>75</u>		<u>66605</u> sum	
107	93		
<u>100</u>	50		
<u>10700</u>	<u>143</u>		
	75		
	715		
	1001		
	<u>10725</u>		

Offsets taken on the line BC

50	72	181	
<u>60</u>	<u>32</u>	<u>25</u>	
<u>3000</u>	104	905	
	150	<u>362</u>	
60	5200	<u>4525</u>	
<u>85</u>	<u>104</u>		
145	<u>15600</u>	3000	} double areas collected
<u>50</u>		7250	
<u>7250</u>	78	7850	
	<u>32</u>	15600	
85	156	2496	
<u>72</u>	<u>234</u>	4525	
157	<u>2496</u>	<u>40721</u> sum	
<u>50</u>			
<u>7850</u>			

Offsets taken on the line CD

100	52	5000	} double areas collected
<u>50</u>	<u>84</u>	9400	
<u>5000</u>	<u>136</u>	6864	
	200	7696	
50	<u>27200</u>	27200	
<u>44</u>		31800	
94	84	12500	
<u>100</u>	<u>75</u>	3750	
<u>9400</u>	159	<u>104210</u> sum	
	200		
156	<u>31800</u>		
<u>44</u>			
624	75		
624	50		
<u>6864</u>	<u>125</u>		
	100		
148	<u>12500</u>		
<u>52</u>			
296	75		
<u>740</u>	<u>50</u>		
<u>7696</u>	<u>3750</u>		

Offsets taken on the line DA

33	50	3300	} double areas collected
<u>100</u>	<u>28</u>	9800	
<u>3300</u>	78	11500	
	100	7800	
33	<u>7800</u>	3220	
<u>65</u>		<u>35620</u> sum	
98	115		
<u>100</u>	<u>28</u>		
<u>9800</u>	920		
	<u>230</u>		
65	<u>3220</u>		
<u>50</u>			
115			
<u>100</u>			
<u>11500</u>			

1270308	}	whole double areas collected
66605		
40721		
104210		
35620		
2)1517464		
7-58732		
4		
2-34928		
40		
13-97120		<i>Area 7a. 2r. 14p.</i>

BY CASTING.

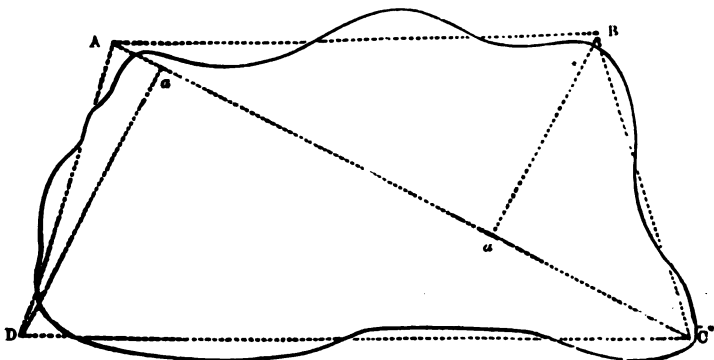

Having constructed the figure, draw the four dotted lines AB, BC, CD, and DA, in such a manner that the parts included may be equal to those excluded; then the diagonal AC will be found = 1364, and the perpendiculars  $Da = 636$ , and  $Ba = 476$  links.

636	}	per.
476		
1112		sum
1364		diag.
4448		
6672		
3336		
1112		
2)1516768		
7-58384		
4		
2-33536		
40		
13-41440		<i>Area 7a. 2r. 13p.</i>

4. It is required to find the area of a field from the following notes.

	BD	
	1460	diag.
	1000	
	return to B	
	AC	
	1480	diag.
	1000	
	R. off A	
	DA	
	672	
	R. off D	
	CD	
	1244	0
	1000	47
	800	70
	600	85
	400	68
	200	30
	000	0
	R. off C	
0	BC	
85	720	
112	650	
88	550	
	450	
	360	cross the fence
	300	83
	200	130
	100	100
	000	0
	R. off B	
	AB	
	1350	
	1000	
Begin at	A	range W.

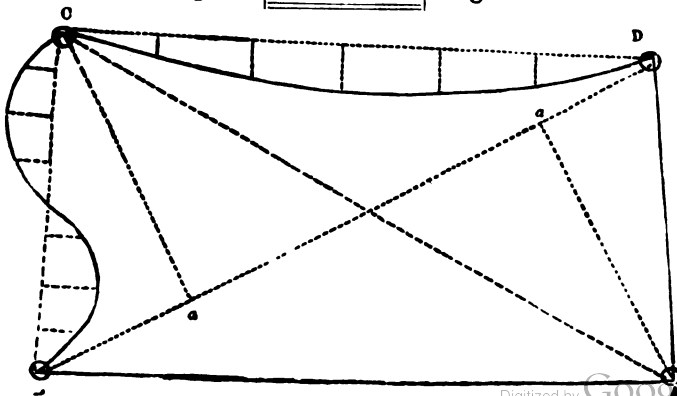

Having constructed the figure, you will find the perpendicular  $ca = 613$ , and the perpendicular  $Aa = 618$  links.

Trapezium ABCD

613	}	per.
618		
<hr/>		
1231	sum	
1460	diag.	
<hr/>		
73860		
4924		
1231		
<hr/>		
1797260		
<hr/>		

Insets taken on the line BC

100	130	10000	}	double areas collected
100	83	23000		
<hr/> 10000	213	21300		
	100	4980		
100	<hr/> 21300	<hr/> 59280		sum
130				
230	83			
100	60			
<hr/> 23000	<hr/> 4980			

Offsets taken on the line BC

88	112	7920	}	double areas collected
90	85	20000		
<hr/> 7920	197	19700		
	100	5950		
88	<hr/> 19700	<hr/> 53570		sum
112				
200	85			
100	70			
<hr/> 20000	<hr/> 5950			

Insets taken on the line CD		
200	85	6000
<u>30</u>	<u>70</u>	19600
<u>6000</u>	155	30600
	<u>200</u>	31000
30	<u>31000</u>	23400
<u>68</u>		<u>11468</u>
98	70	122068
<u>200</u>	<u>47</u>	<u>sum</u>
<u>19600</u>	117	
	<u>200</u>	
68	<u>23400</u>	
<u>85</u>		
153	244	
<u>200</u>	<u>47</u>	
<u>30600</u>	1708	
	976	
	<u>11468</u>	

Double areas	
1797260	trapezium ABCD
<u>53570</u>	offsets
1850830	sum
59280	} insets
<u>122068</u>	
181348	sum to be deducted from the above offsets
2)1669482	whole field
8·34741	
4	
<u>1·38964</u>	
40	
<u>15·58560</u>	Area 8a. 1r. 16p.

5. It is required to find the area of a field from the following notes ; neither of the diagonals having been measured in consequence of obstructions.

DA
476
L. off D
CD
618
200
L. off C
BC
443
L. off B
AB
723
192
200
200

*r*, proof-line, 17 to B

from *m* to *n*  
 from A to *m*, on the line AD  
 from A to *n*, on the line AB  
 range E.

Begin at the angle A

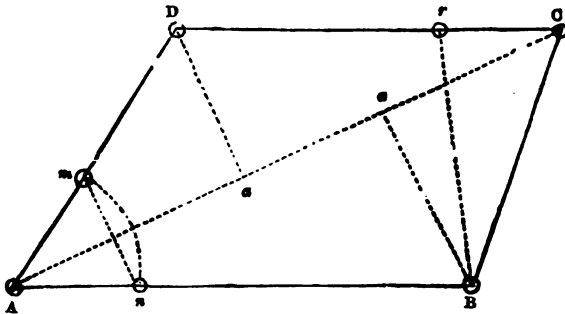

Having constructed the figure, you will find the diagonal AC = 963, and the perpendiculars Da = 257, and Ba = 316 links.

257	}	
316	}	per.
573		sum
963		diag.
<hr/>		
1719		
3438		
5157		
<hr/>		
2)551799		
2·75889		
4		
<hr/>		
3·03596		
40		
<hr/>		
1·43840		<i>Area 2a. 3r. 1p</i>

6. Required the plan and area of a field from the following notes.

	BD 1437 1000 return to B	diag.
	AC 939 L. off A	diag.
	DA 567 L. off D	
	CD 712 L. off C	
	BC 765 L. off B	
Begin at	AB 1457 1000 A	range E.

*Answer.*

Having constructed the figure, you will find one of the perpendiculars = 560, and the other = 166 links; hence the area is = 5a. Or. 34p.

7. It is required to lay down a field, and find its area, from the following notes.

	BD 662 return to B	diag.
	AC 533 L. off A	diag.
	DA 168 L. off D	
	CD 439 L. off C	
	BC 356 L. off B	
Begin at	AB 667 400 200 000 A	0 62 58 0 range E.



*Answer.*

Having constructed the figure, you find one of the perpendiculars = 168, and the other = 218 links ; hence the area is = 1a. 2r. 6p.

8. It is required to lay down a field, and find its area, from the following notes ; neither of the diagonals having been measured in consequence of obstructions.

	CE
	1200
	1000
	L. off C
	AC
	1094
	L. off A
	EA
	1800
	1000
	L. off E
	DE
	837
	L. off D
	BD
	1528
	1000
	860
	L. off B
	AB
	621
	A
Begin at	range N.

*Answer.*

Having constructed the figure, you will find the diagonal BE = 1927, and the perpendiculars = 580 and 637 links respectively ; hence the area is = 11a. 2r. 36p.

9. the plan and area of a field are required from the following dimensions.

	DB
	1730
	return to D
	diag.
	AC
	1660
	R. off A
	diag.

To	the	fence
99	1580	
110	1500	to A
100	1450	
116	1400	
132	1300	
115	1200	
65	1100	
33	1000	
25	950	
40	900	
150	850	
210	800	
250	700	
255	630	
240	550	
218	500	
117	400	
41	300	
18	250	
15	200	
100	150	
140	100	
157	50	
165	000	
	R. off D	
To	the	fence
60	1085	
82	920	to D
80	850	
42	750	
40	700	
121	600	
140	550	
136	500	
70	300	
25	450	
17	300	
14	250	
30	200	
70	150	
92	100	
100	000	
	R. off C	

To	the	fence
52	1440	
70	1340	to c
60	1250	
37	1200	
33	1150	
45	1100	
83	1000	
70	900	
25	800	
12	750	
20	700	
40	650	
48	600	
54	500	
59	450	
60	400	
72	350	
84	300	
70	200	
86	150	
80	100	
75	000	
	R. off B	
To	the	fence
67	1005	
78	930	to B
86	850	
90	750	
75	700	
40	650	
27	600	
36	550	
57	500	
85	450	
78	400	
58	300	
62	200	
79	100	
83	50	
80	000	
Begin	at A and	go N.

*Answer.*

Having constructed the figure, you will find the perpendiculars  $Aa = 810$ , and  $ca = 708$  links.

Double areas

2626140	trapezium ABCD
137945	offsets taken on the line AB
167800	ditto on the line BC
157520	ditto on the line CD
395420	ditto on the line DA
3484825	sum
Area 17a. 1r. 27 $\frac{3}{4}$ p.	

PROBLEM III.

*Fields of more than Four Sides.*

When a field consists of more than four sides, divide it into triangles and trapeziums, agreeably to the directions given in Part III., Prob. V. Then take the dimensions of each, as directed in the last two problems.

NOTE.—Notwithstanding what has already been advanced with regard to taking proof-lines, you are again requested never to omit measuring such distances as will enable you to confirm every part of your survey. Some may perhaps deem this tedious and superfluous; but the satisfaction which a surveyor finds, when his lines meet correctly, fully compensates him for his additional labour.

*Examples.*

1. It is required to find the area of a field from the following notes.

EB	diag.
1510	
1000	
R. off C	
CE	diag.  <i>m</i> , proof-line, goes to D, and measures 285
1238	
1000	
400	
R. off C	
AC	diag.
1200	
1000	
R. off A	
EA	
383	
R. off E	

DE
692
R. off D
CD
620
R. off C
BC
535
R. off B
AB
1334
1000
A

Begin at

range W.

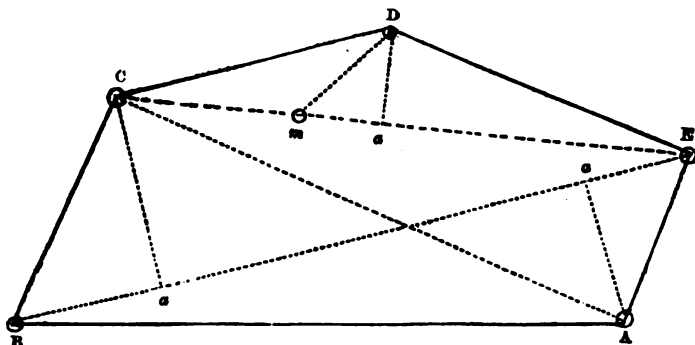

Having constructed the figure, you will find the perpendiculars  $ca = 410$ ,  $Aa = 330$ , and  $Da = 215$  links.

<p><b>Trapezium ABCE</b></p> <table style="width: 100%; border-collapse: collapse;"> <tr><td style="text-align: right;">410</td><td rowspan="2" style="font-size: 2em; vertical-align: middle;">}</td><td rowspan="2" style="vertical-align: middle;">per.</td></tr> <tr><td style="text-align: right;">330</td></tr> <tr><td style="text-align: right;">740</td><td colspan="2">sum</td></tr> <tr><td style="text-align: right;">1510</td><td colspan="2">diag.</td></tr> <tr><td style="text-align: right;">7400</td><td colspan="2"></td></tr> <tr><td style="text-align: right;">370</td><td colspan="2"></td></tr> <tr><td style="text-align: right;">74</td><td colspan="2"></td></tr> <tr><td style="text-align: right; border-top: 1px solid black;">1117400</td><td colspan="2"></td></tr> </table>	410	}	per.	330	740	sum		1510	diag.		7400			370			74			1117400			<p><b>Triangle CDE</b></p> <table style="width: 100%; border-collapse: collapse;"> <tr><td style="text-align: right;">1238</td><td>base</td></tr> <tr><td style="text-align: right;">215</td><td>per.</td></tr> <tr><td style="text-align: right;">6190</td><td></td></tr> <tr><td style="text-align: right;">1238</td><td></td></tr> <tr><td style="text-align: right;">2476</td><td></td></tr> <tr><td style="text-align: right; border-top: 1px solid black; border-bottom: 3px double black;">266170</td><td></td></tr> </table>	1238	base	215	per.	6190		1238		2476		266170	
410	}			per.																															
330																																			
740	sum																																		
1510	diag.																																		
7400																																			
370																																			
74																																			
1117400																																			
1238	base																																		
215	per.																																		
6190																																			
1238																																			
2476																																			
266170																																			
<table style="width: 100%; border-collapse: collapse;"> <tr><td style="text-align: right;">1117400</td><td rowspan="2" style="font-size: 2em; vertical-align: middle;">}</td><td rowspan="2" style="vertical-align: middle;">double areas</td></tr> <tr><td style="text-align: right;">266170</td><td style="vertical-align: middle;">collected</td></tr> <tr><td style="text-align: right; border-top: 1px solid black;">2) 1383570</td><td colspan="2"></td></tr> <tr><td style="text-align: right;">691785</td><td colspan="2"></td></tr> <tr><td style="text-align: right;">4</td><td colspan="2"></td></tr> <tr><td style="text-align: right; border-top: 1px solid black;">367140</td><td colspan="2"></td></tr> <tr><td style="text-align: right;">40</td><td colspan="2"></td></tr> <tr><td style="text-align: right; border-top: 1px solid black; border-bottom: 3px double black;">2685600</td><td colspan="2"></td></tr> </table> <p style="text-align: right;"><u>Area 6a. 3r. 27p.</u></p>	1117400	}	double areas	266170	collected	2) 1383570			691785			4			367140			40			2685600														
1117400	}			double areas																															
266170		collected																																	
2) 1383570																																			
691785																																			
4																																			
367140																																			
40																																			
2685600																																			

2. It is required to find the area of a field from the following notes.

DA 1042 return to D	diag.
CE 420 R. off C	diag.
AC 768 R. off A	diag.
EA 585 R. off E	
DE 518 R. off D	
CD 365 L. off C	
BC 390 R. off B	
AB 1054 600 A range W.	

Begin at

*m*, proof-line, goes to *C*  
and measures 260

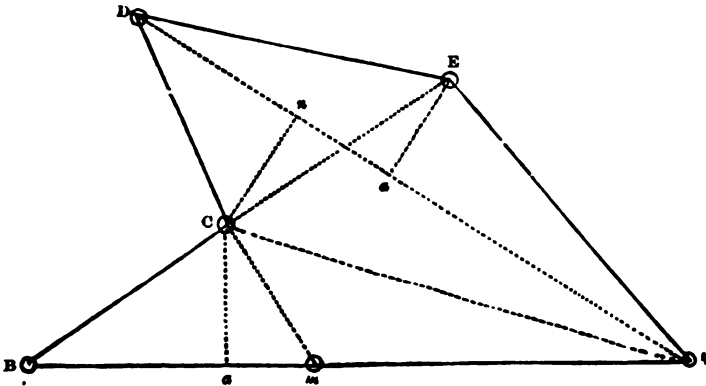

Having constructed the figure, you will find the perpendiculars  
 $Ca = 223$ ,  $Cn = 200$ , and  $Ea = 176$  links.

Triangle ABC	Trapezium ACDE
1054 base	200
223 per.	176 } per.
<u>3162</u>	<u>376 sum</u>
2108	1042 diag.
2108	752
<u>235042</u>	1504
	<u>376</u>
	<u>391792</u>

235042	}	double areas collected
<u>391792</u>		
2)626834		
3·13417		
4		
<u>·53668</u>		
40		
<u>21·46720</u>		<i>Area 3a. Or. 21p.</i>

3. It is required to find the area of a field from the following notes.

FB 660 return to F	diag.
BE 970 L. off B	diag.
DB 268 L. off D	diag.
AD 832 R. off A	diag.
FA 285 L. off F	

	EF
0	384
40	300
53	200
32	100
0	000
	R. off E
	DE
	804
	L. off D
	CD
0	383
52	200
0	000
	R. off C
	BC
	475
	300
	R. off B
	AB
	850
Begin at	A

range W.

*m*, proof-line, goes to D,  
and measures 255

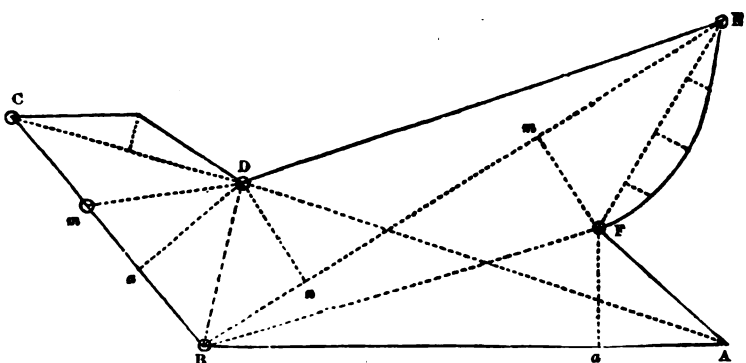

Having constructed the figure, you will find the perpendiculars  $Fa = 185$ ,  $Fm = 185$ ,  $Dn = 190$ , and  $Dz = 216$  links.

Triangle ABF	
850	base
185	per.
<u>4250</u>	
6800	
850	
<u><u>157250</u></u>	

Trapezium BDEF	
185	} per.
190	
<u>375</u>	sum
970	diag.
<u>26250</u>	
3375	
<u><u>363750</u></u>	



Triangle BCD	Offsets taken on the line CD
475 base	383
216 per.	52
<u>2850</u>	<u>766</u>
475	1915
950	<u>19916</u>
<u>102600</u>	

	Offsets taken on the line EF	
32	53	3200
100	40	8500
<u>3200</u>	93	9300
	100	3360
	<u>9300</u>	<u>24360</u> sum
32		
53		
85	84	
100	40	
<u>8500</u>	<u>3360</u>	

157250	} double areas collected
363750	
102600	
19916	
<u>24360</u>	
2)667876	
3-33938	
4	
1-35752	
40	
<u>14-30080</u>	<i>Area 3a. 1r. 14 p.</i>

4. It is required to lay down a field, and find its area, from the following notes.

DB	diag.
1440	
1000	
return to D	
AC	diag.
1078	
L. off A	
EA	diag.
1324	
1000	
return to E.	

DF	diag.
712	
L. off D	
AD	diag.
818	
L. off A	
FA	
755	
L. off F	
EF	
692	
L. off E	
DE	
754	
R. off D	
CD	
540	
L. off C	
BC	
1048	
L. off B	
AB	
1360	
1000	
A	range E.

Begin at

*Answer.*

Having constructed the figure, and divided it into two trapeziums, ABCD and ADEF, you will find the perpendicular which falls from the angle C upon the diagonal DB = 315 links, and that which falls from the angle A upon the same diagonal = 758 links.

The perpendicular which falls from the angle D upon the diagonal EA, you will find = 425 links, and that which falls from the angle F upon the same diagonal = 287 links.

Hence the area is = 12a. 1r. 30p.

5. Required the plan and area of a field from the following notes.

EB	proof-line
424	
R. off E	
FE	diag.
750	
L. off F	
MF	
400	
R. off M	

HM 460 R. off H	227 to K, proof-line
LH 700 R. off L	
DL 430 return to D	
FL 740 R. off F	diag.
HF 730 400 R. off H	diag. K
DH 920 R. off D	diag.
GD 950 return to G	diag.
GE 580 R. off G	
FG 630 R. off F	
DF 540 R. off D	diag.
AD 1050 R. off A	diag.
EA 450 R. off E	
DE 670 R. off D	diag.
CD 500 R. off C	
AC 780 500 A	B range W.

Begin at

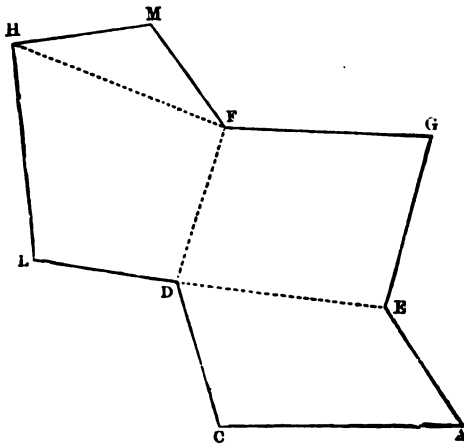

*Answer.*

Having constructed the figure, you will find the perpendiculars of the trapezium ACDE = 354 and 195 ; of DFGE = 404 and 340 ; of DLHF = 426 and 316 ; and the perpendicular of the triangle FHM = 227 links. Hence the area of the field is = 10a. 2r. 25p.

6. Required the plan and area of a field from the following dimensions.

	BD 1480 to B	diag. line 14
Return	GE 1725 G	diag. line 13
L. off	CG 1295 C	diag. line 12
L. off	FC 935 F	diag. line 11
L. off	DF 793 D	diag. line 10
R. off	GD 358	
0	300	
37	250	
49	200	
60	150	
66	100	
62	50	
30	000	
0	G	line 9
R. off		

	<b>FG</b>	
	0	783
	78	700
	134	650
	154	600
	170	550
	172	500
	150	450
	185	400
	208	350
	205	300
	180	250
	149	200
	107	150
	62	100
	24	50
	0	000
R. off	<b>F</b>	line 8
	<b>EF</b>	
	0	1043
	36	1000
	67	900
	85	800
	100	700
	140	600
	152	550
	143	500
	135	450
	110	400
	65	350
	50	300
	40	200
	25	100
	0	000
R. off	<b>E</b>	line 7
	<b>CE</b>	
	0	743
	70	600
	135	500
	160	450
	185	400
	190	350
	179	300
	150	250
	95	200
	60	100
	0	000
R. off	<b>C</b>	line 6
	<b>DC</b>	diag.
	1000	
L. off	<b>D</b>	line 5

	AD	
	700	0
	600	50
	500	130
	450	160
	400	173
	350	118
	300	190
	250	150
	200	107
	100	60
	000	0
L. off	A	line 4
	CA	
	1578	diag.
R. off	C	line 3
	BC	
0	865	
60	750	
104	650	
72	600	
88	500	
100	400	
86	350	
75	300	
95	200	
80	100	
70	000	
R. off	B	line 2
To	the	fence
80	1830	
73	1750	
60	1600	
56	1500	
70	1400	
95	1300	
120	1200	
105	1100	
110	1000	
140	900	
186	800	
184	700	
125	600	
114	500	
93	400	
86	300	
75	200	
70	100	
0	000	
Begin at	A	range W, line 1

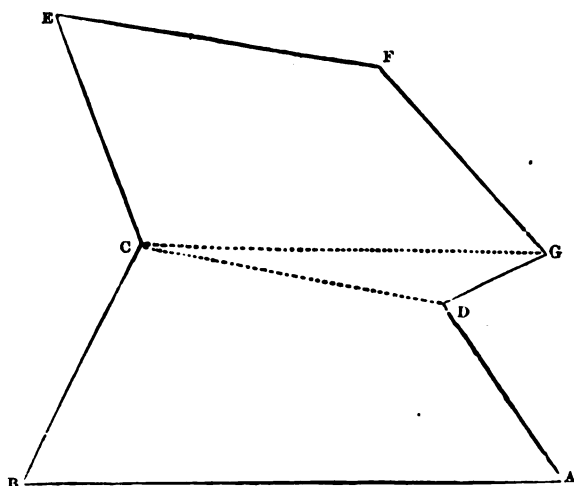

NOTE.—The preceding figure represents the chain-line, forming the two trapeziums and the triangle, in the 6th Example.—When the learner constructs the figure, he must of course lay down the offsets from the notes, and dot all the chain-lines as before directed.

*Answer.*

Having constructed the figure, you will find the perpendiculars of the trapezium ABCD, falling upon the diagonal CA, to measure 862 and 314 links; the perpendicular of the triangle DGC, falling upon the diagonal CG, to measure 184 links; and the perpendiculars of the trapezium CEFG, falling upon the diagonal GE, to measure 513 and 300 links.

Double areas

1855728	}	trapezium ABCD
238280		triangle DGC
1402425	}	trapezium CEFG
362460		offsets taken on the line BC
133750	}	ditto on the line BC
143250		ditto on the line AD
149010	}	ditto on the line CE
157548		ditto on the line EF
200374	}	ditto on the line FG
30696		ditto on the line GD
<u>4673521</u>		sum

*Area 23a. 1r. 18 $\frac{3}{4}$  p.*

7. Draw a plan of a small estate, consisting of four fields, and find the respective areas of the different inclosures, and the contents of the whole, from the following dimensions.

NOTE.—The field-notes in this Example are entered from the left towards the right; but in all the foregoing Examples, they are entered from the right towards the left. Both methods are consequently exhibited; and, of course, the learner is at liberty, when he commences field-practice, to follow that of which he most approves.

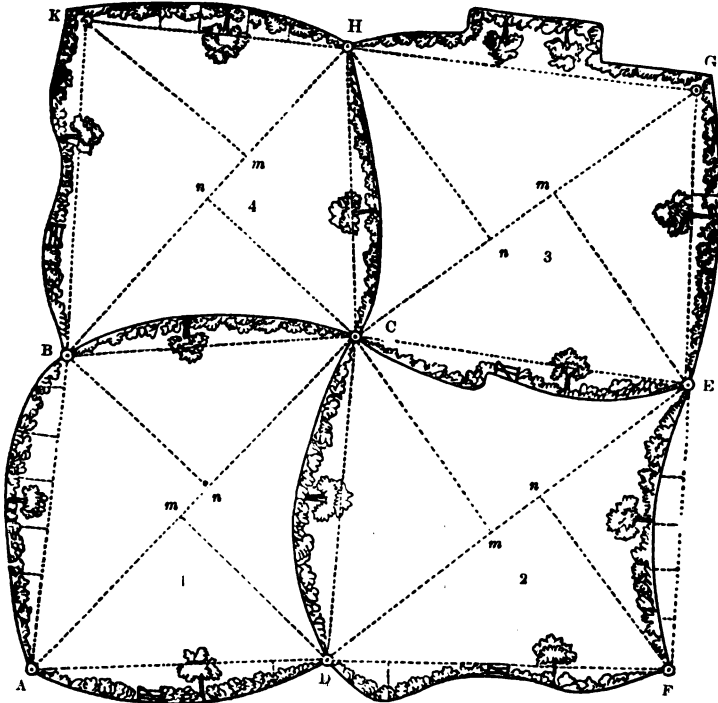

Scale 4 Chains to an Inch.

	To B	
0	662	
53	600	
88	500	
96	400	
92	300	
70	200	
35	100	
0	000	
Begin at	A	and go N. line 1



	<b>To E</b>	
	712	0
	600	43
	500	52
	400	45
	340	gate
	274	28 + 52
	200	76
	100	42
	000	0
Go from	c	line 6
	<b>To c</b>	
	685	
54	600	
92	500	
105	400	
100	300	
78	200	
44	100	
0	000	
Go from	d	line 5
	<b>To D</b>	
	632	0
	600	24
	500	55
	400	78
	300	82
	250	gate
	200	76
	100	58
	000	0
Go from	A	line 4
	<b>To A</b>	
	995	diag.
Go from	c	line 3
	<b>To c</b>	
0	615	
46	500	
53	400	
62	300	
60	200	
50	100	
0	000	
Go from	B	line 2

	To H	
	750	0
	700	18
	600	38
	490	60+35
	350	104
	220	15+80
	100	25
	000	30
Go from	G	line 11
To	the	fence
	668	22
To G	638	24
	600	26
	500	42
	400	48
	300	45
	200	30
	100	18
	000	0
Go from	E	line 10
	To E	
	965	diag.
Go from	D	line 9
	To D	
0	735	
32	700	
75	600	
55	500	
20	430	
Gate	380	
28	300	
42	200	
40	100	
0	000	
Go from	F	line 8
	To F	
	593	0
	500	30
	400	52
	300	57
	200	48
	100	32
	000	0
Go from	E	line 7

	Finis	
	To H	
Go from	895 B	diag. line 16
	To B	
	720	0
	600	40
	500	48
	460	gate
	400	32
	350	18
	300	28
	200	68
	100	55
	000	34
Go from	K	line 15
To	the	fence
	580	28
To K	546	30
	500	32
	400	46
	300	45
	200	40
	100	34
	000	0
Go from	H	line 14
	To G	
Go from	908 C	diag. line 13
	To C	
0	624	
54	500	
65	400	
63	300	
52	200	
30	100	
0	000	
Go from	H	line 12

*Answer.*

Having drawn the plan, you will find the perpendiculars of the different trapeziums to measure as follow, viz. :—

$Dm = 426$ , and  $Bn = 400$ , in No. 1 ;  
 $Cm = 503$ , „  $Fn = 448$ , „ No. 2 ;  
 $Hn = 515$ , „  $Em = 498$ , „ No. 3 ; and  
 $Cn = 428$ , „  $Km = 439$ , „ No. 4.

## AREA OF NO. 1.

Double areas
821870 trapezium ABCD
84786 offsets on AB
54890 ditto on BC
72968 ditto on AD
<hr/> 1034514 sum
93790 insets on CD
2) 940724 difference
4·70362 <i>Area</i> in square links
<hr/> 4
2·81448
<hr/> 40
<hr/> <u>32·57920</u> <i>Area</i> 4a. 2r. 32½ p.

## AREA OF NO. 2.

Double areas
917715 trapezium DCEF
93790 offsets on CD
55510 ditto on DF
<hr/> 1067015 sum
60758 insets on CE
43590 ditto on EF
<hr/> 104348 sum
962667 difference
<hr/> <hr/> <i>Area</i> 4a. 3r. 10p.

## AREA OF NO. 3.

Double areas
919804 trapezium CEGH
60758 offsets on CE
42480 ditto on EG
81310 ditto on GH
<hr/> 1104352 sum
54096 insets on CH
<hr/> 1050256 difference
<hr/> <hr/> <i>Area</i> 5a. 1r. 0p.

## AREA OF No. 4.

Double areas
775965 trapezium BCHK
54096 offsets on CH
41024 ditto on HK
57200 ditto on KB
<hr/>
928285 sum
54890 insets on BC
873395 difference
<hr/>
<i>Area 4a. 1r. 18½p.</i>

## CONTENT.

No.	A.	R.	P.
1. . . . .	4	2	32½
2. . . . .	4	3	10
3. . . . .	5	1	0
4. . . . .	4	1	18½
Sum	19	0	21

NOTE 1. In the last example every field is measured separately; but they are so connected by the chain-lines that no difficulty can arise to the learner in planning them. It may also be observed that no proof-lines were measured; but they should never be omitted in practice: if they be, the surveyor cannot depend upon the accuracy of his work.

2. If the foregoing estate be laid down upon a sheet of drawing paper, by a scale of one chain, or of two chains to an inch, a finished plan may then be made and ornamented with Indian ink, in a similar manner to Plates IX. and XI. Or the quickwood hedges may be made by a pen and Indian ink; or they may be represented by running narrow shades of colouring along the lines which form the boundaries of the fields; and each field may then be washed over with a different colour, mixed up thinly with water, and laid on with a small brush or camel's hair pencil. (See Part V. for the method of transferring a rough plan to a clean sheet of paper, in order to make a finished plan, with proper embellishments.)

3. In drawing the finished plan, all the out-boundaries may be considered as belonging to the fields which they respectively adjoin; that fence from *b* to *c* may be made as belonging to No. 1, that from *c* to *d* as belonging to No. 2, that from *c* to *e* as belonging to No. 3, and that from *c* to *h* as belonging to No. 4. (See a remark on the 27th page relating to fences.)

4. The title of the finished plan of the foregoing estate may run thus:—Plan of an Estate lying in the Parish of Bradford, in the West-Riding of the County of York.

## PROBLEM IV.

*Meres and Woods.*

The method of measuring Meres and Woods by the Chain and Cross has already been shown in Part III. It is here proposed to survey them by the Chain only.

In this case, you must not only measure on the outside of the mere, or wood, and take insets as before directed; but also take such external angles, or tie-lines, as will enable you to lay down the figure.

*Example.*

Let the following figure represent a mere, the area of which is required:—

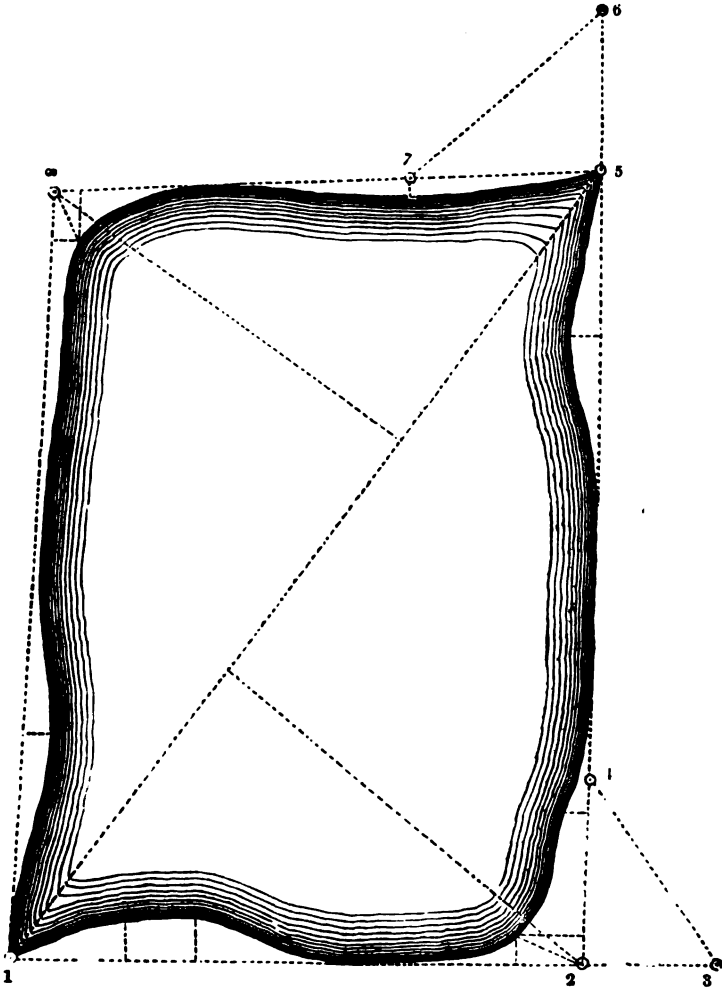

Begin at + 1, and measure eastward as far as + 2, taking insets as you proceed; then produce the line to + 3. Return to + 2, and measure northward as far as + 4; thence run a line backward to

+ 3, which will tie the first and second lines. Return to + 4, continue the line to + 5, and produce it to + 6. Return to + 5, and proceed westward to + 7, the distance between which and + 6, being measured, will tie the second and third lines. Return to + 7, and continue the line to + 8. From + 8 proceed to + 1, and you will have obtained the following dimensions.

NOTE.—Here it may be observed that after the first three lines are laid down, the fourth line will exactly reach from + 8 to + 1, if the operations have been performed with correctness.

	0	1625	to + 1
	60	1100	
		1000	
	23	800	
	30	600	
	60	96	
	0	000	
	From	+ 8	go S.
	0	1150	to + 8
	100	1100	
		1000	
	0	900	
	0	700	
	40	400	+ 7, which is 550
	0	000	from + 6
	Return to	+ 5 and	go W.
		2000	to + 6
	0	1650	+ 5
	56	1300	
	0	1000	
	0	550	
		400	+ 4, which is 490
	40	300	from + 3
	103	48	
	0	000	
	Return to	+ 2 and	go N.
		1500	to + 3
	0	1200	+ 2
	50	1100	
		1000	
	0	850	
	0	600	
	100	400	
	80	250	
	0	000	
	Begin at	+ 1	range E.

*Answer.*

Having constructed the figure, you will find the diagonal, drawn from + 1 to + 5 = 2085, the perpendicular from + 2 upon the diagonal = 950, and that from + 8 = 890 links.

## Double areas

3836400 trapezium made by stations 1, 2, 5, and 8.

84500	} 1 line	} insets taken on the different lines
87380	} 2 ,,	
53000	} 3 ,,	
118120	} 4 ,,	
343000	whole insets	
3493400	mere	

*Area 17a. 1r. 35p.*

## PROBLEM V.

*To measure and plan Roads, Rivers, Canals, &c.*

In measuring roads, rivers, or canals, angles or tie-lines must be taken at the different turns, in order to lay down the chain-lines; and offsets must be taken to the boundaries, as you proceed to enable you to draw the plan.

**NOTE 1.** The length of a road is generally returned either in miles, furlongs, and poles, or else in miles and yards. (See the Table, page 30.)

2. A machine called a "Perambulator" is sometimes used to ascertain the lengths of roads. It has a wheel of 8 feet 3 inches, or half a pole, in circumference, which being made to pass over the ground, puts in motion the clockwork within; and the distance measured is pointed out by an index on the outside. This instrument is much more expeditious for measuring the length of a road than the chain, but it is certainly less correct; for by the wheel passing over stones, sinking into holes &c., the distance is made to appear more than it is in reality.

*Examples.*

1. Let the following figure represent a serpentine road, a plan of which is required.



Begin at + 1, and measure to + 3, taking offsets on both sides, as you proceed. Return to + 2, and measure to + 4, from which run a line to + 3, which will tie the first and second lines. Return to + 4, and continue the line to + 6. From + 6, proceed as before, until you arrive at + 14; and you will have obtained the following dimensions, from which a plan may be drawn.

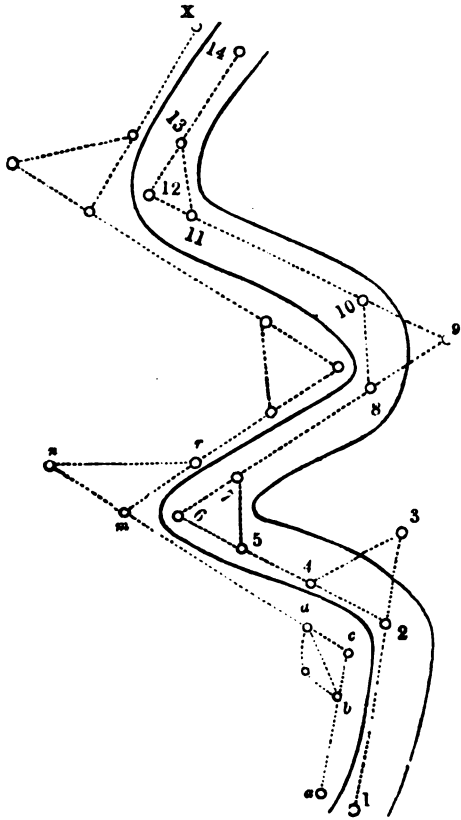

	To + 14	
58	350	60
68	200	44
	150	+ 13 is 184 from + 11
50	100	80
Go from	+ 12	line 5
	To + 12	
30	720	
70	650	
	600	+ 11
86	550	33
70	300	50
	200	+ 10 is 200 from + 8
120	135	cross-fence
Go from	+ 9	line 4

	To + 9	
	700	
	600	cross-fence
	500	+ 8
38	480	84
40	300	60
52	180	65
	150	+ 7 is 160 from + 5
50	100	
Go from	+ 6	line 3
	To + 6	
20	512	
50	450	
52	380	70
	350	+ 5
20	300	80
	200	+ 4 is 232 from + 3
18	100	93
Go from	+ 2	line 2
	To + 3	
	600	
	480	cross-fence
	400	+ 2
38	350	95
15	300	
28	200	80
55	000	70
Begin	at + 1	line 1

2. Let the foregoing figure represent a river, a plan of which is required.

Begin at *a*, and measure to *c*, taking offsets to the river's edge as you proceed. From *c* measure to *d*, and there take the tie or chord-line *db*, which will enable you to lay down the first and second lines. Continue the second line to *n*, and from *m* measure to *r*, at which place take the tie-line *rn*; and thus proceed until you come to the end of your survey at *x*.

The breadth of a river, if it be everywhere nearly the same, may be taken in different places by the next problem or by Problem X. Part III.; but if it be very irregular, dimensions must be taken on both sides, as above.

When the area is required, it must be found from the plan, by dividing the river into several parts, and taking the necessary dimensions by the scale.

NOTE.—Any bog, marsh, mere, or wood whatever may be its number of sides, may be measured by this problem.

## PROBLEM VI.

*Taking Distances by the Chain and Scale.*

## EXAMPLE.

Required the distance of an object at A, from B.

First, make a station at B; then, in a direct line with BA, set up a pole, suppose at C; measure the distance BC. Return to B, and measure in any direction, making an angle with BC, suppose to D; then set up a pole in a direct line with DA, as at E. Measure the lines DE and EC, and also the diagonal CD; these will enable you to construct the trapezium BCED.

The lines BC and DE, produced, will evidently meet at A.

Measure the line BA with the same scale by which you have constructed the trapezium, and it will be the distance required.

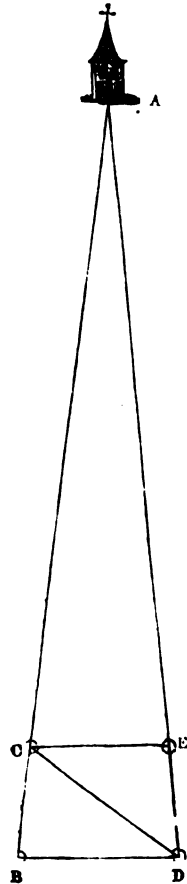

## PROBLEM VII.

*To erect a Perpendicular by the Chain, or to measure Lines upon which there are Impediments.*

## EXAMPLE.

Suppose CDEF to represent the base of a building, through which it is necessary a line should pass from A, to an object at B, the direction  $AMB$  on the side A being given.

Measure from A to  $m$ ; and from  $m$ , measure back to  $a$ , 40 links. Let one end of the chain be kept fast at  $a$ , and the eightieth link at  $m$ ; take hold of the fiftieth link, and stretch the chain so that the two parts  $an$  and  $mn$  may be equally tight: then will  $mn$  be perpendicular to  $am$ .

For  $mn$  will be 30,  $am$  40, and  $an$  50 links; or the sides of the right-angled triangle  $amn$  will be in proportion to each other as 3, 4, and 5. (See Prob. XVIII. Part I.)

Measure from  $m$ , upon the line  $mn$  continued, until you are clear of the impediment, as at  $c$ ; than continue the line 40 links farther, to  $b$ . Find by the above process the perpendicular  $cd$ ; and proceed in that direction till you are beyond the building, as at  $h$ . Again erect the perpendicular  $he$ , upon which measure till you have made  $hp$  equal to  $mc$ ; and you will then be in a direct line with  $mA$ . Erect the perpendicular  $pz$ , which (if you have conducted the work with correctness) will be in a right line with B. Measure the distance  $pB$ ; then  $Am$ , added to  $ch$  ( $=mp$ ), and  $pB$ , will give the whole length of the line  $AB$ .

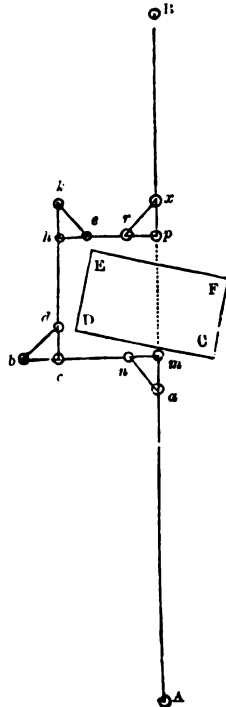

## PROBLEM VIII.

*Having the Plan of a Field, and its true Area, to find the Scale by which it has been constructed.*

**RULE.**—By any scale whatever measure such lines as will give you the area of the figure: then say, as this area is to the square of

the scale by which it was found, so is the true area to the square of the scale required.

*Example.*

Suppose the true area of a field, the plan of which is given, to be 9a. 1r. 32p.; and that by a scale of 2 chains to an inch, I find the area to be 4a. 0r. 32p.; required the scale by which the plan was constructed.

First, 9a. 1r. 32p. = 945000 square links; and 4a. 0r. 32p. = 420000 square links; then, as 420000 : 4 :: 945000 : 9. Hence it appears the plan was constructed by a scale of 3 chains to an inch.

NOTE.—The principle of this process is, that the areas of similar figures are to each other as the square of their homologous sides. (Theo. XVI. Part I.)

---

### HILLY GROUND.

The survey of a hill is taken conjointly upon the horizontal and vertical planes. Both planes are generally required to determine the area as represented upon the plan. The details of the vertical survey are shown by sections.

There are three methods practised in finding the area of a hill, viz., the horizontal, the hypotenusal, and the superficial.

The *first way* is that which determines the horizontal area. It accords with trigonometry on the horizontal plane, and is that which is generally practised in Land-surveying.

The *second way* gives the hypotenusal area, and also the angle which the hypotenusal plane makes with the horizon. Surveys of this kind are frequently ordered for plantation and other grounds, and for whole estates when they lie on the sloping sides of large hills.

The *third way* returns the superficial area. It is generally adopted for paring and burning, trenching, ploughing, reaping, and other agricultural works.

*Methods for reducing Hypotenusal to Horizontal Lines.*

## METHOD I.

When the hill is of a regular slope, take its altitude with a theodolite, or with a quadrant; then, by a trigonometrical canon, in which the hypotenuse may be counted 100 links, determine the number of links in the base. These deducted from 100 will show the number of links by which each chain must be shortened, for the purpose of planning.

*Example.*

Suppose the altitude of a hill to be  $16^\circ 15'$ , and the length of a line measured upon its surface to be 2550 links; required the length of the line that must be used in planning.



In the right-angled triangle ABC are given the hypotenuse  $AC = 2550$ , and the angle  $BAC = 16^\circ 15'$ , to determine the base AB. Or  $AD = 100$ , and the angle  $EAD = 16^\circ 15'$ , to find AE.

As radius	.	.	.	.	.	.	10·00000
Is to the hypot. $AD = 100$ links	.	.	.	.	.	.	2·00000
So is the co-sine of the angle $EAD = 16^\circ 15'$	.	.	.	.	.	.	9·98229
To $AE = 96$ links	.	.	.	.	.	.	<u>1·98229</u>

Hence it appears that 4 links must be subtracted from each chain; consequently  $(25 \times 4 + 2 = )$  102 links must be taken from AC; hence  $AB = 2448$  links, the line required.

PROOF.—As, 1 : 2550 ::  $\cdot 96005$  (the nat. co-sine of  $16^\circ 15'$ ) :  $2448\cdot1275$  links = AB.

NOTE.—Surveyors, when serving an apprenticeship, acquire a knowledge of how to drive the chain in hilly ground; and those who master this branch of their profession approximate very closely to the length of horizontal lines found by trigonometry.

*A Table for reducing Hypotenusal to Horizontal Lines.*

Different Altitudes of Hills.		Links to be subtracted from each Chain measured upon the Surface.	Different Altitudes of Hills.		Links to be subtracted from each Chain measured upon the Surface.
Deg.	Min.	Links.	Deg.	Min.	Links.
5	44	1	29	32	13
8	6	1	30	42	14
11	28	2	31	47	15
14	4	3	32	52	16
16	16	4	33	54	17
18	12	5	34	55	18
19	57	6	35	54	19
21	34	7	36	52	20
23	4	8	37	49	21
24	30	9	38	44	22
25	51	10	39	39	23
27	8	11	40	32	24
28	21	12			

NOTE.—To construct the above table, suppose the base AB, in the preceding triangle to be = 99.5, and the hypotenuse AC = 100; then by Trig. as 100 : 1 :: 99.5 : 99.5, the nat. co-sine of the angle BAC = 5° 44'. In the same manner, the rest of the angles are obtained, by different operations, accounting the base 99 in finding the second angle, 98 in finding the third, &c.

QUADRANTS AND THEIR USE.

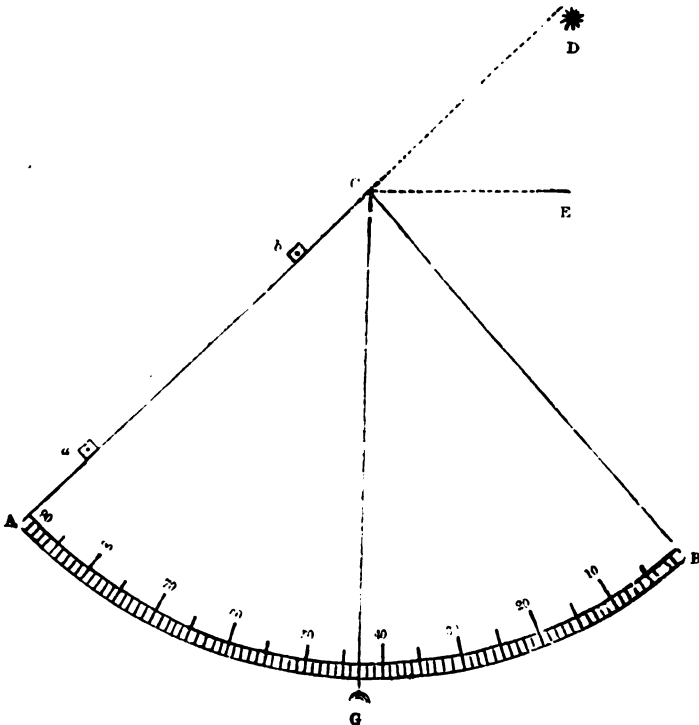

Quadrants differ in construction, but are similar in principle. The instrument is for taking vertical angles. In surveying, it has been nearly superseded by the semicircle of the theodolite and spirit-level, and in astronomy by the mural circle.

1. The annexed diagram ABC represents a quadrant of the simplest mechanism. It is suspended from C either by the hand or top of a staff, the plumb-line CG being the index. The sights through which the object at D is viewed are two small holes drilled in the brass plates *a* and *b* on the radius AC.

2. Another example is similar to the last, a telescope being substituted for the brass sights on AC.

3. A third kind has a spirit-level on the radius BC, which is placed horizontally on CE; the quadrant or arc BA is towards D; and a telescope is affixed longitudinally on the revolving index CG, through which the object is viewed.

4. A fourth construction has a spirit-level on AC, which is placed horizontally on CE; BC is towards the object; and the telescope is now fixed tangentially upon the revolving index at the circumference of the arc, the line of collimation thus forming a tangent.

*To take the Altitude of a Hill with the Quadrant.*

Upon the top of the hill fix an object, exactly as high as your eye will be from the ground, in taking the observation. At the bottom of the hill fix the quadrant staff perpendicularly to the horizon, which may be easily done by means of the plummet. Then with one eye at A, the other being closed, look through the sights, turning the quadrant until you perceive the object at D; so will the arc BG, cut off by the plumb-line CG, be the measure of the angle DCE, or the altitude of the hill, in degrees, above the horizon.

*To take the Altitude of a Steeple, &c. with the Quadrant.*

Screw the quadrant fast to its staff, so that the plummet may hang exactly at  $45^\circ$  when the staff is perpendicular to the horizon. Then move the staff backward or forward (always keeping it perpendicular), until you can see the top of the object through both the sights. Measure the distance between the bottom of the staff and that of the object, which being added to the height of your eye, will give the altitude required.

METHOD II.

As the foregoing method of reducing hypotenusal to horizontal lines can only be applied, with accuracy, when hills are of a regular slope, surveyors, in general, elevate the chain, as they ascend or descend a hill, in order to preserve the horizontal line.

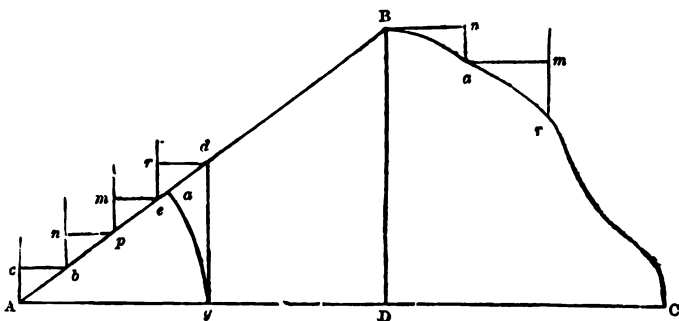

*Examples.*

Suppose the lines AB and BC to represent the acclivity and declivity of an irregular hill, it is required to measure them, and to preserve the horizontal line AC.

From A stretch the chain toward B, and suppose it to reach to  $a$ ; the same extent, upon the base, will evidently reach from A to  $g$ ; and a perpendicular erected from  $g$  will intersect the line AB in  $d$ ; hence the distance  $Ad$ , upon the hypotenuse, will make one chain upon the base. At A, stick your offset-staff into the ground, perpendicularly to the horizon, and let your assistant hold the chain, suppose at the twenty-fifth link, close to the surface of the hill, as at  $b$ ; at the same time you must elevate the end of the chain to  $c$ , forming the horizontal line  $cb$ ; then move forward to  $b$ , at which place fix your staff again, as before. Let your assistant hold the fiftieth link at  $p$ , while you elevate the twenty-fifth to  $n$ , forming the horizontal line  $np$ . Again, fixing your staff at  $p$ , elevate the fiftieth link to  $m$ , while your assistant holds the seventy-fifth at  $e$ . Lastly, put down the staff at  $e$ , and elevate the seventy-fifth link to  $r$ , while the hundredth is held by your assistant at  $d$ . There he must put down an arrow, and thus you must proceed until you arrive at B, where you will have obtained the horizontal line AD.

In descending from B to C, let your assistant hold one end of the chain at B, while you elevate, suppose, the fiftieth link to  $n$ , forming the horizontal line  $Bn$ ; then fix the staff at  $a$ , perpendicularly to the horizon, and touching the chain at  $n$ . Next, let your assistant hold the fiftieth link at  $a$ , while you elevate the hundredth to  $m$ , and put down the staff at  $r$ , as before. In this manner, having arrived at C, you will have obtained the horizontal line DC, which being added to AD, will give the base or horizontal line AC, as required.

NOTE 1. If you wish to obtain the hypotenusal, as well as the horizontal line, divide your field-book into four columns, in one of which you must enter the number of links between *a* and *d*, &c., which being added to the horizontal will give the hypotenusal line.

2. When the ascent or descent of a hill is great, you will not be able to elevate more than 10 or 15 links of the chain at one time; for, in such cases, if you attempt to elevate 20 or 30 links, you will find that the perpendiculars *ac*, *bn*, &c. will exceed your own height before you can form the horizontal lines *cb*, *np*, &c. (See the last Figure.)

### METHOD III.

Hypotenusal lines may likewise be reduced to horizontal ones during the survey by quadrants constructed for the purpose. Of these two examples are subjoined, viz. King's Quadrant and Nesbit's Quadrant.

### KING'S QUADRANT.

#### *Description.*

'The quadrant is fitted to a wooden square, which slides upon an offset-staff, and may be fixed at any height by means of a screw, which draws in the diagonal of the staff, thus embracing the four sides, and keeping the limb of the square perpendicular to the staff. The staff should be pointed with iron to prevent wear. When the staff is fixed in the ground on the station-line, the square answers the purpose of a cross staff, and may, if desired, have sights fitted to it. The quadrant is three inches radius, of brass, is furnished with a spirit-level, and is fastened to a limb of the square by means of a screw.

'When the several lines on the limb of the quadrant have their first division coincident with their respective index-divisions, the axis of the level is parallel to the staff.

'The first line next the edge of the quadrant is numbered from right to left, and is divided into 100 parts, showing the number of links in the horizontal line which are completed in 100 links on the hypotenusal line, and in proportion for any smaller number.

'The second, or middlemost line, shows the number of links the chain is to be drawn forward, to render the hypotenusal measure the same as the horizontal.

'The third, or uppermost line, gives the perpendicular height, when the horizontal line is equal to 100.'

*Use.*

‘Lay the staff along the chain-line on the ground, so that the plane of the quadrant may be upright ; then move the quadrant till the bubble stands in the middle, and on the several lines you will have—1. The horizontal length gone forward in that chain ; 2. The links to be drawn forward to complete the horizontal chain ; 3. The perpendicular height or descent made in going forward one horizontal chain.

‘The first two lines are of the utmost importance in surveying land, which cannot possibly be planned with any degree of accuracy without having the horizontal line ; and this is not to be obtained by any instrument in use without much loss of time to the surveyor ; whilst with this he has only to lay his staff along the ground, and set the quadrant till the bubble is in the middle of the space, which is very soon performed. And he saves by it more time in plotting his survey than he can lose in the field ; for as he completes the horizontal chain as he goes forward, the offsets are always in their right places, and the field-book being kept by horizontal measure, his lines are sure to close.

‘If the superficial content, by the hypotenusal measure, be required for any particular purpose, he has that likewise, by entering in the margin of the field-book the links drawn forward in each chain, having thus the hypotenusal and horizontal length of every line.

‘The third line, which is the perpendicular height, may be used with success in finding the height of timber. Thus, measure with a tape of 100 feet the surface of the ground from the root of the tree, and find by the second line how much the tape is to be drawn forward to complete the distance of 100 horizontal feet ; and the line of perpendiculars shows how many feet the foot of the tree is above or below the place where the 100 feet distance is completed.—Then, inverting the quadrant by means of sights fixed on the staff, place the staff in such a position as to point to that part of the tree whose height you want ; and sliding the quadrant till the bubble stands level, you will have on the line of perpendiculars on the quadrant the height of that part of the tree above the level of the place where you are ; to which add or subtract the perpendicular height of the place from the foot of the tree, and you obtain the height required.’

NESBIT'S QUADRANT.

PLATE II.

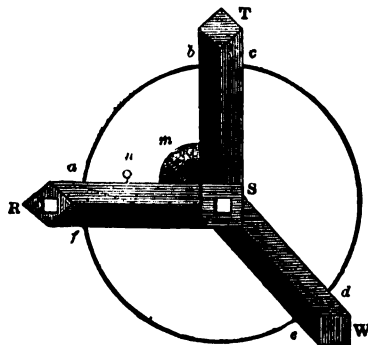
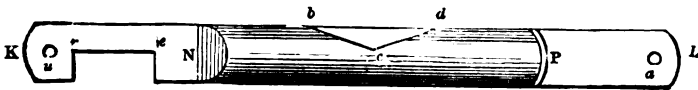
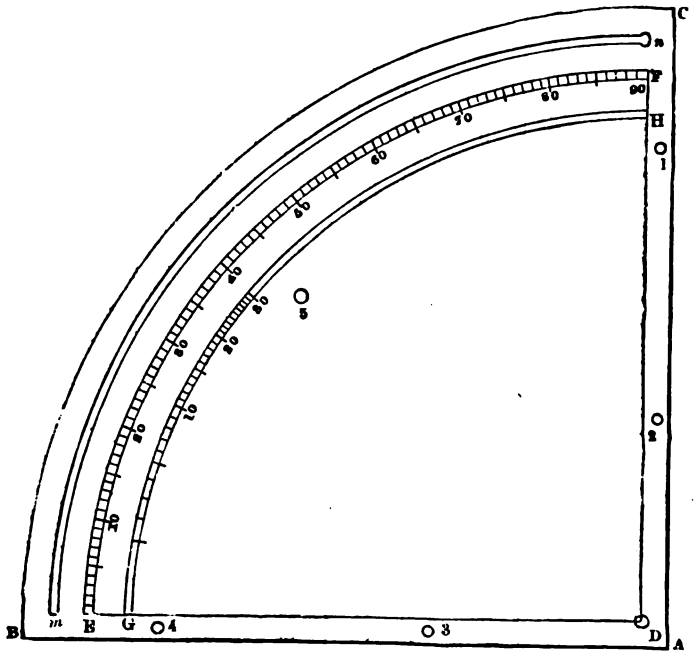

The following table, by which the Quadrant may be constructed, shows the number of links to be drawn forward upon the surfaces of hills of different altitudes to complete the horizontal chains.

Deg. Min.	Links	Deg. Min.	Links	Deg. Min.	Links
5 43	$\frac{1}{2}$	41 44	34	53 28	68
8 4	1	42 12	35	53 43	69
11 22	2	42 40	36	53 58	70
13 52	3	43 7	37	54 13	71
15 57	4	43 34	38	54 27	72
17 45	5	43 59	39	54 41	73
19 22	6	44 25	40	54 55	74
20 50	7	44 50	41	55 9	75
22 12	8	45 14	42	55 23	76
23 27	9	45 38	43	55 36	77
24 37	10	46 1	44	55 49	78
25 43	11	46 24	45	56 2	79
26 46	12	46 46	46	56 15	80
27 45	13	47 8	47	56 28	81
28 42	14	47 30	48	56 40	82
29 35	15	47 51	49	56 53	83
30 27	16	48 11	50	57 5	84
31 16	17	48 32	51	57 17	85
32 4	18	48 52	52	57 29	86
32 49	19	49 11	53	57 40	87
33 33	20	49 30	54	57 52	88
34 16	21	49 49	55	58 3	89
34 57	22	50 8	56	58 15	90
35 37	23	50 26	57	58 26	91
36 15	24	50 44	58	58 37	92
36 52	25	51 2	59	58 48	93
37 28	26	51 19	60	58 58	94
38 3	27	51 36	61	59 9	95
38 38	28	51 53	62	59 19	96
39 11	29	52 9	63	59 30	97
39 43	30	52 26	64	59 40	98
40 14	31	52 42	65	59 50	99
40 45	32	52 58	66	60 0	100
41 15	33	53 13	67		

*The Construction of the preceding Table.*

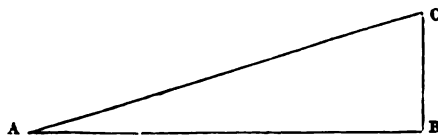

In the right-angled triangle ABC, suppose the base AB to be 100,

and the hypotenuse AC 100·5 ; then by trigonometry as  $100\cdot5 : 1 :: 100 : \cdot99502$ , the co-sine of the angle  $BAC = 5^\circ 43'$ . In the same manner, the rest of the angles are obtained by different operations, accounting the hypotenuse 101 in finding the second angle, 102 in finding the third, &c.

Now from the preceding table it evidently appears that if an instrument be constructed to take the altitude of a hill at every chain, if necessary, and a line traced upon the instrument be so divided as to exhibit the number of links which the chain must be drawn forward upon the surface of the hill, to complete the horizontal chain according to the table, it may be used in surveying hilly ground.

*The Method of constructing the Quadrant, &c.*

Procure a piece of soft sheet-brass, and upon it draw the lines AB and AC perpendicular to each other, and with a radius of five inches describe the quadrant BC.

Next, draw the lines DE and DF perpendicular to each other; and with four inches in your compasses for the first sweep describe the double arc EF, which divide correctly into 90 equal parts or degrees. At a proper distance, likewise, from the arc EF describe the double arc GH, and the double arc *mn*. Of these, the latter must be cut through the brass by a file.

You must also procure a small glass tube, nearly filled with spirit (generally called a "spirit-level"), and a piece of sheet-brass KL, in length equal to AB, and in breadth rather exceeding the diameter of the tube, which call the "index."

Then procure another piece of sheet-brass in the form of a semi-cylinder NP, large enough to admit the tube; and in it make the aperture *bcd*, in order to see the bubble.

Its edges solder to the index KL, so that the centre *c* may be exactly in the middle point between *r* and *a*; *ra* rather exceeding DE, and *au* being exactly equal to *dm*. The end N must also be closed up by soldering a piece of brass upon it, and the end P left open in order to admit the tube.

Next, make a wooden quadrant, exactly the size of ABC, and in it a groove corresponding with the aperture *mn*, and large enough to admit a small screw-nail, with a square head and neck, so as to run, but not to turn round, in the groove *mn*.

Then fix the plate ABC to the wooden quadrant, by the counter-sunk screws, 1, 2, 3, 4, 5; taking care first to insert the screw-nail above mentioned into the aperture *mn*, at a small hole made for that purpose at *n*.

Next, fix the index *KL* upon the face of the quadrant by a screw-nail passing through it at *a*, which must enter the quadrant exactly at the centre *D*. The nail in the aperture *mn* must likewise pass through the hole at *u*, and upon the end of this nail must be screwed a small nut, by which the end *K* of the index may be made fast at any altitude.

Now, to divide the arc *GH* move the end *K* of the index toward *c*, until the line or edge *re*, which must be exactly in the centre of the index, cuts the arc *EF* at  $8^{\circ} 4'$ , as per table; and upon the arc *GH* mark the first division. In the same manner, move the index until it cuts of  $11^{\circ} 22'$ , and there mark the second; continuing these operations until you have made as many divisions as are necessary.—The divisions marked upon the arcs *EF* and *GH*, must then be properly cut and figured by an engraver.

Next, procure a wooden cross, *RTSW*, the three limbs of which must each be in length equal to *AB* or *AC*, and must form with each other three right angles, *RST*, *TSW*, and *WSR*.

This cross must be made to slide upon an offset-staff by means of a square or rectangular aperture through the limb *RS*; and if a screw be fixed in the side of the limb at *n*, the cross may be fastened to the staff at any convenient height, by turning the screw against the side of the staff. As it will be somewhat difficult, however, on account of the limb *RS* being hollow, to make a joint at *s* sufficiently strong to keep the limbs at right angles with each other, they may be supported by means of the brackets *ab*, *cd*, and *ef*. The quadrant *ABC* must then be fixed upon the square *RST*, by means of two screws passing through the bracket *ab*, and one through the bracket *m*, so that the outside of the limb *SR* may coincide with *AB*, and the outside of the limb *ST* with *AC*.

To fix the tube or spirit-level correctly in the semi-cylinder *NP*, screw the index fast at no altitude, and place the edge *AB* of the quadrant upon a level table, which you may do by laying the tube upon it, and varying the position of the table until the bubble stands in the centre of the tube; then put the tube into the semi-cylinder *NP*, and fix it in such a manner that the bubble may be seen at *c*; after which close up the end *P* with brass or putty.

NOTE.—If the quadrant be made the same size as that in Plate II. instead of five inches radius, as before directed, it will save much trouble in dividing, as the engraver may then follow the divisions given in the plate.

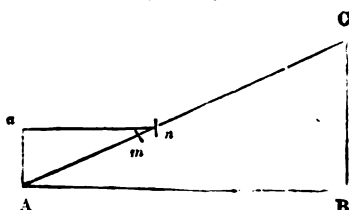
*The Method of proving the Quadrant.*

Let AC represent a strong plank, placed with one end against the perpendicular wall BC, and the other upon the horizontal plane AB. Lay an offset-staff, suppose of 12 links, upon AC, with one end at A and the other at *m*; then elevate the lower end, so that the staff *an* may be parallel to AB. Measure the distance *mn*, which suppose to be 10·5 inches; then say, as 12 links is to 10·5 inches, so is 100 links to 87·5 inches, or 11 links.

Next, lay the edge AB of the quadrant upon the plank AC, and elevate the end K of the index until the bubble stands at *c*; and if the index cuts off 11 links, or nearly so, upon the arc GH, the quadrant is correct.

*The Method of using the Quadrant.*

Lay the staff, with the quadrant fixed to it, along the chain-line, so that the edge AB of the quadrant may come in contact with the ground; then elevate the end K of the index until the bubble stands at *c*; and you will have the altitude of the hill upon the arc EF, and the number of links to be drawn forward to complete the horizontal chain upon the arc GH. If you fix the bottom of the staff into the ground upon the chain-line, the limbs ST and SW will serve as a cross by which perpendiculars may be erected.

NOTE 1. In using the quadrant, care should be taken to place it upon the even part of the surface of the hill.

2. In measuring and reducing a line upon a hill, if it happen that the end of the chain reaches exactly to the station at the end of the line, you must then deduct from the chain instead of drawing it forward. For example; if you find that the chain ought to be drawn forward 6 links, you must set down 94 instead of 100 links. Or, if the fiftieth link reach to the station, you must enter 47 instead of 50 links, &c.

3. If you determine, by elevating the chain, and also by the quadrant, the number of links to be drawn forward upon the surface of a hill, in order to complete the horizontal chain, you will seldom find them precisely the same; because it is almost impossible to prevent the chain from forming a curve line, or to keep the staff perpendicular to the horizon. In every case, however, the conclusions of an instrument constructed upon mathematical principles are to be preferred.



*Methods for finding the Hypotenusal Measure of Hilly Ground.*

This is by far the most difficult part of surveying ; and, though we may approach toward, we can seldom obtain the true area of hills, because their surfaces are generally so irregular that it is almost impossible to divide them into proper figures.

If the land to be surveyed lie in the form of a square, rectangle, trapezoid, trapezium, or triangle, against the side of a hill of a regular slope, take the dimensions and find the area in the same manner as if the figure lay upon a plane. But should it be required to find the area of a field (suppose in the form of a trapezium) in which there is a hill so situated as to affect the diagonal only, if the sides and diagonal be measured, and the figure laid down according to those dimensions, the perpendiculars will obviously measure less than they would have done, had the diagonal been reduced to a horizontal line ; consequently, we cannot obtain the hypotenusal measure of such a field by the common method of measuring trapeziums or triangles.

In such cases, it is perhaps best, first, to measure the hill only. For this purpose, surround its base by station-staves, dividing it into an irregular polygon, each side of which must be measured. Then fix upon a convenient place near the top of the hill for a station, and between it and each station at the bottom measure a line. Thus will the whole surface be divided into triangles, the areas of which must be found by laying down each triangle separately. Or, from the three sides, you may find the area of each triangle, as already directed.

Next, measure the remainder of the field, by dividing it into proper figures. Collect all the areas together, and their sum will be the area required.

When the land to be surveyed ascends a hill on one side, occupies a plane upon the top, and descends on the other side, you must divide it into such figures as will enable you to approach as nearly as possible to the true area.

The foregoing directions may, perhaps, be found useful to a learner, but, in practice, much will always depend upon the surveyor ; he ought, therefore, to be very careful, whatever be the shape or size of the hill, to divide it into such squares, rectangles, trapezoids, trapeziums, or triangles, as are most likely to give him the hypotenusal measure.

NOTE 1. In surveying a triangular field, of which one side passes over a hill, the other two being upon the horizontal plane of the base, it will be necessary to

divide it into two triangles, by measuring a line from some part of the fence passing over the hill to the opposite angle. Thus will two sides of each triangle be affected by the hill, the areas of which, found separately, will give the hypotenusal measure of the field.

2. After making some experiments, and considering the subject very maturely, the author is of opinion that the most correct method of finding the surfaces of hills in general, is to take the dimensions in such a manner that the areas of the different figures into which the hills are divided, may be found from the lines measured in the field, without having recourse either to the scale or plan. Hence, if the figures be rectangles, their lengths and breadths must be measured in the field; and if they be triangles, trapeziums, or trapezoids, their bases and perpendiculars must be measured in the field.

*Examples.*

1. The length (or hypotenusal line) of a rectangular field, lying upon the side of a hill of regular ascent, is found to be 900 links, its breadth 800 links, and the altitude of the hill  $28^{\circ} 21'$ ; required the hypotenusal measure, and the length of the line that must be used in planning :

$$\begin{array}{r}
 900 \\
 \quad 800 \\
 \hline
 7\cdot20000 \\
 \quad 4 \\
 \hline
 \cdot80000 \\
 \quad 40 \\
 \hline
 32\cdot00000 \text{ Area 7a. Or. 32p.} \\
 \hline
 \hline
 \end{array}$$

Now, by the table, page 142, we find that 12 links must be deducted from each chain; hence  $9 \times 12 = 108$ , which being taken from 900, leaves 792 links, the length of the line required.

NOTE.—If we multiply 792 by 800, we find the product 633600 square links equal to 6A. 1R. 14P. the horizontal measure, which is less than the hypotenuse by 3R. 18P.

2. Let ABCD represent a field in the form of a trapezium, lying upon the side of a hill of an irregular ascent, the sides AB and BC being upon the horizontal plane of the base; required the horizontal and hypotenusal measures from the following notes :

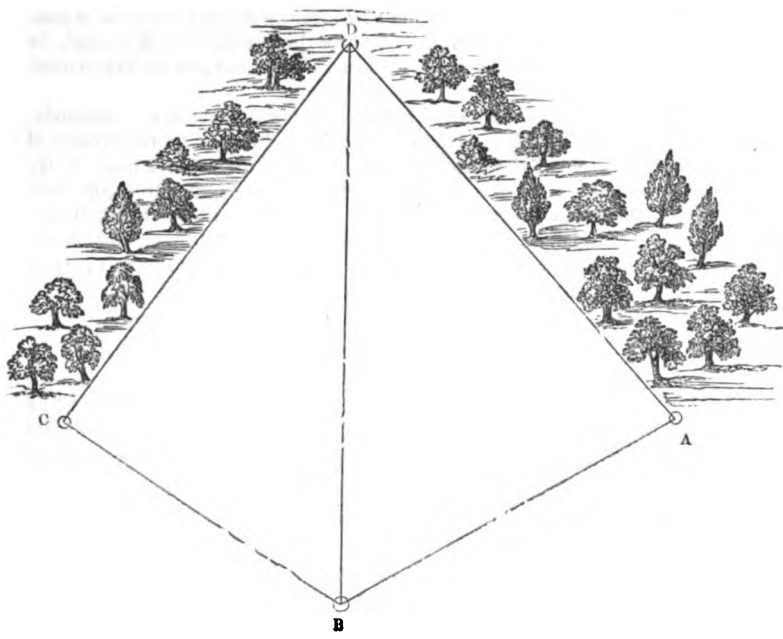

	110	BD
	6	1154
	12	1100
	11	1000
	12	900
	10	800
	11	700
	10	600
	8	500
	9	400
	7	300
	8	200
	6	100
From	B	go N.
		diag.
		diag. reduced for
		a proof-line
		AC
		1300
		R. off A

78	DA
6	990
7	800
9	700
8	600
7	500
9	400
10	300
11	200
11	100
	R. off D
96	CD
5	1044
10	1000
11	900
12	800
11	700
9	600
10	500
8	400
7	300
6	200
7	100
	R. off C
	BC
	800
	R. off B
	AB
	700
Begin at	A

range S. W.

*The Operation of finding the horizontal Measure.*

First,  $700 + 1154 + 990 = 2844$ , the sum of the three sides, which being divided by 2, gives 1422. From this number deduct severally each side, and we obtain 722, 268, and 432, for the three remainders. Then, by multiplying the half sum and the three remainders continually together, and extracting the square root of the product, we obtain 344768 square links, the horizontal measure of the triangle ABD.

In a similar manner, we find the horizontal measure of the triangle BCD = 405559 square links; which, added to 344768, gives 750327 square links, equal to *7a. 2r.* the horizontal measure of the trapezium ABCD.

*The Operation of finding the hypotenusal Measure.*

First,  $1154 + 110 = 1264$ , the hypotenusal line BD; and  $990 + 78 = 1068$ , the hypotenusal line DA. Then,  $700 + 1264$

+ 1068 = 3032, the sum of the three sides, which being divided by 2, gives 1516. From this number, deduct severally each side, and we obtain 816, 252, and 448, for the three remainders. Then, proceeding as before, we obtain 373709 square links, the hypotenusal measure of the triangle ABD.

In a similar manner we find the hypotenusal measure of the triangle BCD = 437917 square links, making jointly 821626 square links, equal to *8a. 0r. 34p.* the hypotenusal measure of the trapezium ABCD, which exceeds the horizontal measure by *2r. 34p.*

*General Directions for the Vertical Survey of a Hill.*

Let ABC, in the diagram page 144, represent the transverse section of a hill, AC its base, and B an object at the top of the hill or section, whose altitude is represented by the perpendicular BD. The line BD may also indicate the plane of a longitudinal section.

The line AB is assumed to show the acclivity of the hill lying in the hypotenusal plane; and the crooked line B $\gamma$ C the declivity on the opposite side where the surface diverges from the hypotenusal plane BC, this line not being drawn.

The line AB being the base-line of the survey on that side of the hill from which the bearings are taken, it requires to be carefully measured with the chain, the same as if it lay on the horizontal plane in horizontal surveying.

The lines AD and BD (or any other lines parallel to them that may be required) are determined by trigonometry in the following manner:—

The angle BAD is found by taking the angle of depression at B, the two angles being equal (Theo. III. Part I.), and their complement ABD should be taken at the same time as a check angle.

The angle of elevation taken at A does not give the correct angle BAD, because the perpendiculars at A and B represent radii, and therefore are not parallel: whereas a line drawn from A so as to make with AB the complement of BAD is parallel to BD.

The two lines BD and AD remaining undetermined may be found by the following formulæ, AB being taken as the common radius.

1. To find BD,  $R : \sin A :: AB : BD$
2. To find AD,  $R : \cos A :: AB : AD$
3. To find AD,  $R : \sin B :: BA : AD$
4. To find BD,  $R : \cos B :: BA : BD$

Any other points in AB as *d* may thus be determined, the triangle *Adg* being similar to the triangle ABD.

The details of the survey on the opposite side of the hill are more complicated, owing to the uneven surface or crooked line B $\gamma$ C involv-

ing oblique-angled triangles and impediments to sight between the station-poles at B and C. Thus, if the flag-staff at B cannot be seen from station C extend the base line, *if practicable*, as in Prob. V. Sect. V. Part VIII. until it becomes visible, at which place set a station-pole E, and take a second distance in the same direction to station F for a base line. Measure EF with the chain, and take the two adjacent angles at E and F with the quadrant or theodolite. Their sum deducted from  $180^\circ$  gives the other angle of the triangle EBF. BE is now found by Case I. Sect. III. Part VIII. Next take the angle of depression at B and its complement EBD, which will give the angle E sought, when BD and DE may be found by the above formulæ; measure CE with the chain and deduct it from DE, which will give CD.

The hypotenuse BC and the angles which it makes with BD and DC remain undetermined, and may be found from the following formulæ, BC being, in 1 and 2, the common secant sought, and the lines found, BD and DC, tangent and radius; but, in 3 and 4, it is radius and BD and DC sin and cos.

1. To find BC,  $R : \sec B :: BD : BC$
2. To find CB,  $R : \sec C :: CD : CB$
3. To find B,  $BC : CD :: R : \sin B$
4. To find C,  $CB : BD :: R : \sin C$

If the base line EF cannot be found in the horizontal plane AC, so that the station-poles E and F are seen from B, then an intermediate station-pole may be placed farther down the hill, as at  $r$ , making a triangle  $BCr$  within the vertical plane;  $rCE$  and  $rCF$  being without. Should this hypothesis fail, then a base line must be taken upon a different plane, say upon the opposite hill, and the hypotenusal line BC or  $rC$  found from the bearings taken thereon, as directed in Sect. VI. Part IX. Or the whole of the survey may be taken downwards from the top of the hill; and as the details of the operation are similar to those already given, with the exception that the offsets are taken from parallels by means of the levelling staff, they may be left for the student to work out as a simple but instructive exercise.

Of surveys involving less or more details of the above kind on the vertical plane, the following familiar examples may be enumerated.

1. In mountainous district roads ascend from the valleys, climbing zigzag along the sides of high hills, and not unfrequently pass over the tops of low ones. Their formation often involves a vast amount of levelling, and before such work can be undertaken, a vertical as well as a horizontal survey is necessary.

2. In many places a vertical section is necessary to show the true elevation, climate, and position of towns and other places.

3. When a survey is ordered with a view to determine the geological character, or the agricultural and mineral value, of an estate, a vertical section is required to show the depth of the soil, and the geological strata below. Geological surveys and maps furnish an illustration.

4. Large areas of peat-moss are to be found on hill-sides, and when the moss forms a 'live bog' a survey may be ordered on public grounds: the safety of the inhabitants farther down the hill being in danger.

5. Quarries of slate, marble, and stone for building are often situated towards the top of hills, and surveys are required to ascertain the depth of earth upon the rock (as in Example 3), the thickness of the strata, the elevation, and probable expense of opening and working.

6. On the Wealden and other clays, low hills often yield fine brick-earth; hence the nature of the survey.

7. Gravel is found drifted into low hills and flat table-lands in districts where it possesses a high value for road-making and building purposes; hence the survey.

8. Fortifications and other military works often involve a large amount of vertical surveying.

9. It has often been proposed to give a true plan of a country by means of miniature hills and valleys, and several exceptional surveys of this kind have been made. The position of the hills and valleys determine the direction of the transverse and longitudinal sections.

10. Railways, embankments, rivers, canals, &c., give rise to a larger amount of vertical surveying than any of the preceding examples. Special directions for surveys of this kind will be found in subsequent parts of the work.

## PART V.

## THE METHOD OF SURVEYING AND PLANNING LARGE ESTATES.

VARIOUS METHODS are adopted in taking the dimensions of large estates or lordships, of which the following four examples may be given.

## METHOD I.

Having made yourself acquainted with the form of the estate, select two suitable places, at the greatest convenient distance from each other, as grand stations ; and measure a principal base, or what is generally called a "main-line," from one to the other, noting every hedge, brook, or other remarkable object, as you cross or pass it ; taking offsets likewise to the bends or corners of the hedges that are near you.

Next, fix upon some other suitable place, towards the outside of the estate, as a third grand station ; to which, from each extremity of the diagonal or main-line, or from two convenient points in it, lines must also be run.

These three lines being laid down, will form one large triangle ; and in a similar manner, if necessary, on the other side of the diagonal or main-line a second triangle may be formed.

The survey must then be completed by forming smaller triangles on the sides of the former, and measuring such lines as will enable you to obtain the fences of each enclosure, the boundaries of rivers, roads, lakes, &c. &c., and prove the whole work.

NOTE 1. If the estate be of a triangular form, three lines must be run in the most convenient manner, so as to form the largest triangle possible ; after which other lines must be measured, offsets taken, &c. &c. ; so that all the fences may be obtained, and the survey completed, as in Plate VIII.

2. When an estate is divided into two triangles, it is generally best to finish one of them before you measure any of the internal lines of the other, as in Plate III. Sometimes, however, it is more convenient and expeditious to run some lines in the second triangle before you have finished the first, as in Plate X.

3. Estates similar to those in Plates III. and VIII. are very easy to survey, as



they contain no impediments ; but it is otherwise with estates like that in Plate X., where the windings of rivers, roads, and fences, make it necessary to run a great number of lines in order to obtain a correct plan of the whole estate, and the true area and position of every part.

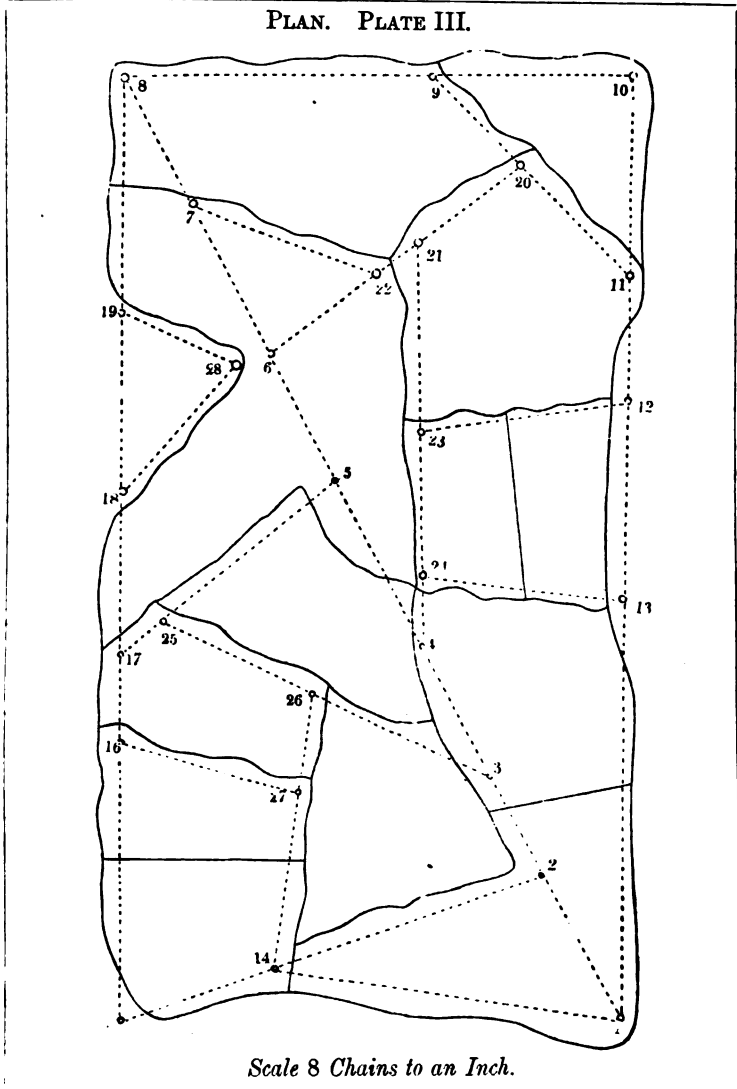

4. In extensive surveys, where two surveyors are employed, it is best to consider the estate as divided into two distinct parts by the main-line. Each surveyor may then take a part, and make use of the base-line between them, and

measure such other lines as are necessary to complete that part of the survey which he undertakes. By this means the lines of one surveyor do not become entangled with those of the other, while the work of both is more expeditiously and correctly performed than if the two were employed on the same side of the main-line.

5. It is sometimes advisable to divide a very large estate in the following manner: Measure a line across the estate as near to the middle as convenient; and at right angles to this line measure another line through the middle of the estate. These two lines being tied together by a connecting line measured from one to the other, will divide the estate into four parts, which may be measured separately by dividing them into triangles, and taking such dimensions as are necessary to complete the survey. This method is more especially advisable where three or four surveyors are employed in measuring a large lordship; for the first two lines being considered as out-boundaries, the estate may be measured in four separate but connected parts.

6. The method of surveying estates by dividing them into triangles is illustrated by Plates III., VIII., and X., the last two of which are actual surveys. The field-notes belonging to them are given in an engraven Field-Book; and Plates IX. and XI. are the finished plans.

7. No notes are given to Plate III., but the directions of the lines may be ascertained by the following particulars: The first, or main-line, leads from + 1 to + 8, the second line from + 8 to + 10, and the third from + 10 to + 1, which three lines form the first large triangle. The fourth line extends from + 2 to + 15, and the fifth from + 15 to + 8, which two lines and part of the main-line form the second large triangle. The sixth line leads from + 9 to + 11; the seventh from + 20 to + 6; the eighth from + 7 to + 22; the ninth from + 21 to + 4; the tenth from + 24 to + 13; and the eleventh from + 12 to + 23; which complete the survey of the first triangle. The twelfth line extends from + 5 to + 17; the thirteenth from + 25 to the main-line southward of + 3; the fourteenth from + 1 to + 14; the fifteenth from + 14 to + 26; the sixteenth from + 27 to + 16; the seventeenth from + 18 to + 28; and the eighteenth from + 28 to + 19; which finish the whole survey.

8. The content of the estate may be found in the following manner: Measure the lines upon the plan, and take the necessary offsets, by a scale of 8 chains to an inch, and enter the dimensions in a Field-Book. From the dimensions thus obtained, draw a plan by a scale of 2 chains to an inch; then straighten the fences, as directed in Part IV. or Part V., and measure diagonals, perpendiculars, &c., from which compute the content of each field. The diagonals, perpendiculars, and contents may be entered in a Book of Castings, similar to those belonging to Plates VIII. and X. Any other scale will do just the same for practice.

9. Taking the dimensions, &c., as directed in the last note, will be found of infinite service to the learner: as it will tend to make him very expert in entering the field-notes, laying down the lines, and casting the contents, which are no small acquisitions towards becoming a complete land-surveyor.

10. In the first edition, the notes were entered from the right towards the left, in the engraven Field-Book; in this edition they are entered from the left towards the right.

11. Some surveyors represent the crossings of fences by lines drawn across the right and left hand columns of the Field-Book; and others by lines crossing the middle column. The author prefers the latter method; but every surveyor will, of course, follow that of which he most approves.

12. Many surveyors enter their notes in a book about four inches and a half in breadth, and fourteen or fifteen in length when opened; and others prefer a book about eight or nine inches long, and seven or eight inches broad when opened. (See the description of the Field-Book, Part II.; and also the engraven Field-Book belonging to Plates VIII., X., and XII.)

## METHOD II.

Measure a main-line as nearly to one of the out-boundaries of the estate as the curves in the hedges will permit; noting the crossings of fences, and taking offsets as before directed.

At a convenient distance measure another main-line parallel, or nearly parallel, to the first line, so that a number of fences running in that direction may be obtained; and from any two stations in the first line measure lines to some station in the second main-line, thus forming a triangle; so will a station in the second main-line become determined or fixed.

From the first main-line to the second, or from the second to the first, measure lines in order to obtain all the fences which run in that direction. The remainder of the fences of the enclosures contained between the first and second main-lines being obtained by running lines in the most convenient manner, you will have completed the dimensions of a portion of the estate, which may then be laid down.

Parallel or nearly parallel to the second main-line, and at a proper distance from it, measure a third; and proceed with the internal lines as before, and you will obtain the dimensions of another portion of the estate, which may also be laid down.

Carry on the survey in a similar manner, until you finish it.

NOTE 1. This method is illustrated by Plate IV. The field-notes are not given; but the following particulars exhibit the directions of all the lines: The first main-line leads from +1 to +6; the second from +6 to +7; and the third line, or second main-line, from +7 to +16. The fourth line extends from +16 to +1; the fifth or tie-line from +16 to +2; the sixth from +2 to +14; the seventh from +17 to +18; the eighth from +12, through +18 to +3; the ninth from +4 to +10; and the tenth line leads from +8 to +5; thus all the fences between the first and second main-lines are obtained.

The eleventh line, or third main-line, leads from +19 to +29; the twelfth from +29 to +16; the thirteenth from +29 to +15; the fourteenth from +15 to +28; the fifteenth from +26 to +13; the sixteenth from +12 to +25; the seventeenth from +23 to +11; the eighteenth from +30 to +31; the nineteenth from +9 through +31 to +22; and the twentieth from +7 to +19, which completes the survey between the second and third main-lines.

The twenty-first line, or fourth main-line, extends from +32 to +40; the twenty-second from +40 to +29; the twenty-third from +40 to +28; the twenty-fourth from +28 to +38; the twenty-fifth from +37 to +27; the twenty-sixth from +24 to +36; the twenty-seventh from +35 to +23; the twenty-eighth from +34 to

+21; the twenty-ninth from +20 to +33; the thirtieth from +32 to +19, which finish the whole estate.

2. In order to practise the learner, a Field-Book may be formed, and the content of the estate found in the same manner as directed in Note 8, Method I.

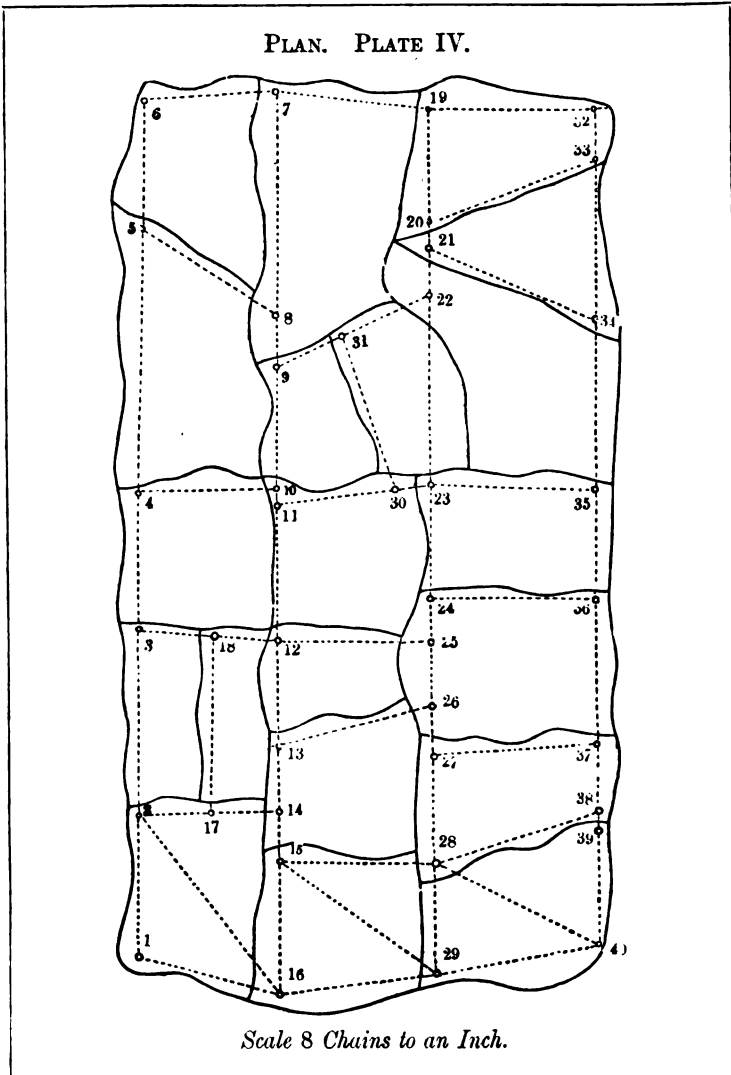

3. Some writers on surveying instruct their pupils to measure main-lines through the estate to be surveyed; and upon these, by the help of a cross, to erect perpendiculars to the opposite angles and curved fences; and upon these perpendiculars

again, if necessary, to erect other perpendiculars ; thus dividing the whole estate into right-angled triangles and trapezoids.

This method is extremely tedious, as many of the perpendiculars will be 12 or 15 chains in length, when the fields are large; and where the fences are much curved, it becomes almost impracticable, in consequence of the great number of offsets that must be taken, in order to obtain a correct plan of the estate.

Besides, when the fence to which perpendiculars must be erected is at a considerable distance from the base-line it will be necessary for an assistant to walk along by the fence, in order to point out to the surveyor the angles and curves to which offsets ought to be taken: and if there be a crooked fence on each side of the base-line, two extra helpers will be necessary, if the surveyor intends to perform his work with expedition. Hence we see that this process of measuring not only subjects the surveyor to a great deal of extra trouble, but also to a very considerable unnecessary expense.

This method I have never followed in measuring estates; neither have I ever seen it followed by any *experienced* surveyor. But where fields are rectangular the contrary may in such cases be the rule, as shown in the opposite page 165.

### METHOD III.

An estate of four sides may frequently be conveniently surveyed as follows: Measure four lines in such a manner that offsets or insets may be taken to the four out-boundaries of the estate; and tie the first and fourth lines together by a diagonal or tie-line measured from one to the other, at the distance of five, six, or more chains from the angular point, according to the extent of the survey; thus you will be enabled to lay down the first four lines, and also the out-boundaries of the estate.

Next proceed to obtain the internal fences, by measuring lines in the most convenient manner; some of which must be run from the first to the third, or from the second to the fourth line; or in some other proper direction, so that they may become proofs and fast-lines, into which other lines may be run with propriety.

In thus proceeding, it is evident that a great deal will always depend upon the dexterity and ingenuity of the surveyor, as no directions can be given that will suit every particular case to be met with in practice.

NOTE.—This method of surveying an estate is exemplified by Plate XII., the field-notes of which are contained in the engraven Field-Book given with this work.

### METHOD IV.

The method which I here intend to describe, is a compound of all the foregoing methods of surveying with the chain; for as there are never two estates to be met with which are exactly alike, sometimes one method claims the preference, and sometimes another;

but a skilful surveyor will always adopt that by which he can take his dimensions and proofs with the greatest accuracy by the fewest lines.

If an estate be in the form of an irregular polygon of five, six, or more sides, and the fences very crooked, such an estate may generally be most easily surveyed by dividing it into triangles, as in Method I ; but if many of the fences of the different enclosures run a considerable way in the same direction, and the fields in general pretty neat trapeziums, it is commonly more eligible to proceed as directed in Method II.

Sometimes an estate varies so much in its shape, that all the methods before described may be used with propriety and advantage ; and it frequently happens that an ingenious surveyor adopts methods in particular cases entirely new to himself ; care, however, must always be taken to make one line depend upon another throughout the whole survey, so that, when you come to lay it down, you may find no lines whose positions are undetermined.

NOTE 1. Whatever method of surveying is adopted, the field-notes must be entered in a similar manner to those given in the engraven Field-Book. Some surveyors place the letter S against straight fences in the Field-Book, to distinguish them from those that are crooked ; but they may be very well denoted by drawing straight or crooked lines, as the case requires.

2. The estates given in this work as examples are not very extensive, in consequence of the serious expense that attends large plates, and the great inconvenience of folding them in books ; but it may be remarked that the foregoing methods of surveying are applicable to estates of all sizes, even to those of many thousand acres.

## MISCELLANEOUS INSTRUCTIONS.

1. When you have an estate to survey, never begin your work too hastily. Walk over the estate, examine it minutely, and observe by which of the foregoing methods it can be most easily measured. Next determine upon that point at which it will be most convenient to begin, and never omit to take the range of the first line with a compass. If you do, it will be impossible for you to lay it down in its true position upon the plan.

2. In measuring your main or any other chain-line, put down stations at every place to which you apprehend it may be necessary to run lines in order to complete the survey.

3. You may sometimes put down a station, whether you see any particular use for it or not ; because it may become serviceable in correcting an error should one be committed ; and if it be not used, it will be immaterial.

4. In measuring your internal lines, it will give you the least trouble to run them from one station to another, if you can make it convenient; if not, you must run them from, and continue them to some chain-line, and measure the distance upon that line to the nearest station, which may be entered in the Field-Book thus: run upon the first line, 30 links S. of + 1, &c.

5. The place where you run upon or cross a chain-line, may be easily ascertained by setting up poles at two of the nearest stations in that line; the crossing will be at the place where you are in a direct line with these poles, which may be represented by marks cut in the ground, pointing out the directions of the lines.

6. In ranging the poles, there must be one fixed at the station from which you intend to depart, and another at the place toward which you direct your line, if there be no natural mark, as a tree, the corner of a house, &c. Then, in a straight line with these marks, put down poles at the distance of 4, 6, or 10 chains from each other, according as impediments may render them necessary.

7. When you are measuring a line across a valley, you must proceed forward until you are likely to lose sight of the station to which you are going; then, let your assistant take a pole to the other side of the valley, and direct him to place it exactly in the line which you are measuring, so as to be seen from the bottom of the valley; to this you may continue your line, and thence to the end.

8. When the stations between which you wish to run a line are so far distant that you cannot see from one of them to the other, or when your view is obstructed by an elevation between them, you must then, accompanied by your assistant, go to the place whence you can distinctly see both; and turning face to face, at a little distance, direct each other to the right or left, until you are both in a right line with the stations; then, one of you putting down a pole, the line will be correctly found. If the line, however, be so long that you cannot possibly find it by the above methods, it must be ranged at random; but, in this case, you should be extremely careful that your pole-ranger keeps one pole in a direct line with another, which he may accurately effect by always having, at least, two behind him.

9. In measuring a line which passes over a hill, you must attend to the directions given in Part IV. in the method of measuring Hilly Ground; but you will not always find your lines to meet correctly in surveying mountainous estates.

10. When a river runs through the estate it will be necessary to continue some of your lines across the river, in order to tie the whole survey together.

11. Rivers, large brooks, public roads, and common sewers, should not be included in the area, but only delineated upon the plan. If, however, their areas be required, they should be given separately.

12. Marshes, bogs, heaths, rocks, &c., belonging to the estate should be distinctly represented upon the plan; and their measurements separately returned.

13. You will generally have an opportunity of representing some part of each hedge in your Field-Book; and you may denote on which side of the ditch the fence stands by drawing a small bush, or by specifying it in writing.

14. In surveying estates, the crossings of fences must be taken at the outer extremities of the ditches, and not at the roots of the quickwood, because the ditch, and not the fence, is the division-line between adjoining fields; but in measuring enclosures which are separated by walls, the case is generally different, as the walls most commonly form the lines of division. It may also be observed that the ground upon which a wall stands must be measured with the field to which the fence belongs; and as walls are generally broader at the bottom than at the top, it is necessary to attend to this circumstance in taking the dimensions.

15. When the surveyor finds it convenient, he may put down stations at the outer extremities of the ditches; and in planning, these stations will, of course, fall upon the black lines, because they always represent the boundaries between adjoining fields. This accounts for several of the stations appearing on the black lines of the rough plans in Plates VIII., X., and XII.

16. In taking a survey, you must enter in your Field-Book the name of each field, or of its proprietor or occupier; or you may make such remarks as will enable you to distinguish the fields from each other, &c., and after the plan is drawn, acquire from persons acquainted with the estate every necessary additional information.

17. When hedges obstruct your sight in running the lines, it will be necessary to cut down part of their tops in order to see the poles.

18. If it should happen that you measure a line for which you have no particular use, it will serve as an additional proof; it is evident that you had better measure too many lines than too few.

19. In taking a survey, you ought to observe to whom the adjoining ground belongs, and specify the same upon the plan.

20. Some of our practical surveyors use only nine arrows. When the leader has advanced ten chains, the follower goes up to him, and places his foot or offset-staff at the end of the chain, instead



of the tenth arrow ; but in this method I do not perceive any particular advantage.

### GENERAL RULES FOR PLANNING LARGE SURVEYS.

The method of laying down a large survey from the Field-Book, may easily be acquired by practice ; but as the least appearance of difficulty generally discourages a learner, it is presumed that the following directions may be found acceptable.

Having provided a sheet of drawing-paper of proper size, trace with a pencil a meridian, or north and south line, in such a manner that your first station may be in some convenient point in this line. Then, from your first station draw your first or main-line, making its proper angle with the meridian-line, which you may then take out with india-rubber.

Next, take separately in your compasses your second and third lines, or any two more convenient ones, forming a triangle with the main-line ; and placing one foot of your compasses in the proper centres respectively, describe arcs intersecting each other. Thus will you have three points from which to form a triangle.

In the same manner proceed with each triangle formed upon the main-line (or upon any other line), proving your work as you advance, until all the triangles are laid down ; and if you find all your lines correctly meet, it will be an infallible proof of the accuracy of the work.

The chain-lines being thus laid down, next prick off the crossings of fences, and draw lines in their proper situations, from one crossing to another, to represent the straight fences.

The curved fence must be formed by laying down the offsets, as already directed.

When the whole survey is planned, all the fences must be drawn with Indian ink, the chain-lines and offsets dotted, and the stations, gates, stiles, &c., marked in their proper places ; the sheet will then represent what is called a 'Rough Plan.'

NOTE 1. When a fence represents a chain-line it must not be dotted.

2. Practical surveyors seldom dot their chain-lines or offsets, but only mark their stations upon the plan ; but it is more satisfactory to a learner to be able to see all his chain-lines at a single view.

3. In taking a very large survey, it is necessary that the work be laid down and proved every night ; for if an error be committed, and the survey continued two or three days before it is discovered, the detection in the field will probably be attended with a great deal of trouble.

4. In laying down large surveys it sometimes happens that one sheet of paper will not contain the whole; in this case, two or more must be pasted together.

5. When you have to lay down a line exceeding the length of your scale, draw a line with your pencil in some convenient place upon the plan, and upon it, at two or more operations, prick off the distance in question, which you may then take in your compasses.

6. Beam Compasses are very useful in drawing large circles. They consist of a long straight beam or bar, carrying two brass cursors; one of them fixed at one end, the other sliding along the beam, with a screw to fasten it. To the cursors may be screwed points of any kind, as of steel, pencils, &c. To the fixed cursor is sometimes applied an adjusting or micrometer screw, by which an extent may be obtained to a very great nicety.

### DIRECTIONS FOR PLANNING THE ESTATE IN PLATE VIII.

*From the dimensions in the engraven Field-Book.*

It appears by the first page of the Field-Book that the range of the first line is NNW.; and by referring to the compass, Plate I. (page 23), we find that the angle which this line makes with the meridian line is  $22^{\circ} 30'$ .

By Prob. XXIII., Part I., lay down a line making an angle of  $22^{\circ} 30'$  with the meridian line; and by a scale of four chains to an inch prick off 2802 links from cross or station (+) 1 to + 3, and you will thus have the part of the first line.

Now, as the third line could not be run to + 1, in consequence of a large quickwood hedge intervening too far to be cut down, it was necessary to produce the first line 30 links southward, in order that the first three lines might form a triangle; consequently, the first line must be continued 30 links southward from + 1, in laying down the plan; and this continuation completes the first line.

Take the second line, 3075 links, in your compasses, and with one foot in + 3, describe an arc; and with 3270 links, the third line in your compasses, and one foot in a point 30 links south of + 1, describe another arc, intersecting the former in + 6; join these three points by drawing lines from + 3 to + 6, and from + 6 to the above-named point, and you will thus form the triangle 1 3 6.

Next, prick off stations 2, 4, 5, 7, and 8; and lay your plotting-scale from + 2 to + 8, and if it measure 1046, as in the Field-Book, line six, you have good reason to conclude that your dimensions are thus far correctly taken and laid down.

Also, mark off + 10, try its distance from + 4; likewise examine the distance from + 5 to + 7; and if you find both these lines the same as in the Field-Book, your survey is evidently correct.

With the fourth line, 257, in your compasses, and one foot in +1, describe an arc; and with the fifth line, 1004, as a radius, and +2 as a centre, make another arc cutting the former in +9; hence you have three points by which to form the triangle 1 9 2.

Lastly, complete the rough plan by pricking off, and drawing all the straight fences; laying down the offsets; showing the gates; numbering the fields, &c. &c., as in the Plate.

### DIRECTIONS FOR PLANNING THE ESTATE IN PLATE X.

*From the dimensions in the engraven Field-Book.*

We find from the fourth page of the Field-Book that the first line ranges W. b. N.  $\frac{1}{2}$  W., making an angle with the meridian line  $84^{\circ} 22\frac{1}{2}'$ .

By Prob. XXIII., Part I., draw a line, making an angle of  $84^{\circ} 22\frac{1}{2}'$  with the meridian line; and by a scale of four chains to an inch, prick off 5445 links from +1 to +12, and you will thus obtain the first line, upon which prick off stations 2, 3, 4, 5, 6, 7, 8, 9, 10, and 11.

With 900 (part of the third line) in your compasses, and +1 as a centre, describe an arc; and with 625, the fourth line, as a radius, and one foot in +2, intersect the former arc in +22. From +2 draw a line to +22; and from +1, through +22, draw the third line, equal to 1360, and you will obtain +23.

With the second line, 3790, in your compasses, and +12 as a centre, describe an arc; and with 925, part of the fifth line, as a radius, and +23 as a centre, describe another arc, cutting the former in +21. From +23, through +21, draw a line equal to 2090, and you will thus obtain the fifth line, and also stations 24, 25, and 26.

Draw a line from +12 to +21, and you will have the second line, and also stations 13, 14, 15, 16, 17, 18, 19, and 20; and draw another from +26 to a point in the first line, 295 W. of +10, and you will obtain the sixth line, and likewise stations 27 and 28.

With 2325, the twenty-sixth line, in your compasses, and +3 as a centre, describe an arc; and with 1210, part of the twenty-seventh line, as a radius, and one foot on the first line, 150 W. of +7, describe another arc, cutting the former in +33. Draw a line from +3 to +33; and from +33, through the intersection of the first line, draw the twenty-seventh line, equal to 2040, and you will obtain +43.

Next, with 446, the seventh line, in your compasses, and +12 as a centre, describe an arc; and with 2528, the eighth line, as a radius and +33 as a centre, describe another arc, cutting the former in +29. Draw lines from +12 to +29, and from +29 to +33, and you will obtain stations 30, 31, and 32; and also draw the ninth line from +32, through +8, and +16, to +27, and you will have stations 34, 35, 36, and 37.

Join stations 11 and 13, and you will obtain the tenth line; 28 and 30, and you will have the eleventh line; 37 and 18, and you will obtain the twelfth line; 19 and 25, and you will have the thirteenth line; 38 and 20, and you will obtain the fourteenth line; 20 and 39, and you will have the fifteenth line; 24 and 39, and you will obtain the sixteenth line; 39 and 19, and you will have the seventeenth line; 17 and 27, and you will obtain the eighteenth line.

From +31, through +9, draw the twentieth line, equal to 1175, and you will obtain stations 40 and 41; join 36 and 40, and you will have the nineteenth line; and from +41, through +34, draw a line to a point in the first line 72 E. of +7, and you will obtain the twenty-first line.

Draw a line from +35 to +43, and you will have +42, and the twenty-third line; and join +42 and +36, and you will obtain the twenty-second line. Draw a line from +23 to the first line, 115 E. of +5, and you will obtain +45, and the twenty-ninth line; from +43 to +45, and you will have +44, and the twenty-fourth line; from +3 to +45, and you will obtain the twenty-fifth line.

Lastly, complete the rough plan, by pricking off, and drawing all the straight fences; laying down the offsets; making the gates; forming the bases of buildings; shading the river; numbering the fields, &c. &c., as in the Plate.

**NOTE 1.** Hot-pressed drawing-paper is best for plans. Parchment and vellum are more durable, and generally used when gentlemen are desirous that the plans may be handed down to their posterity. Vellum exceeds parchment in durability; and it may be necessary to remark, that when either of them is used for planning, it must first be rubbed with clean flannel dipped in the best Paris whiting. This operation clears its surface from grease, and facilitates the movements of the pen.

2. In damp weather paper expands, in dry weather it contracts; consequently, if a plan be drawn when the paper is in a moist state, and the content be not found till after it has become perfectly dry, the diagonals and perpendiculars will measure too little, and will of course give the area too little also; but if the plan be drawn when the paper is dry, and the area be found after it has expanded by a change in the atmosphere, the diagonals and perpendiculars will measure too much, and will consequently give the area too much likewise. Hence the necessity of having the paper in the same state of dryness when you find the area that it was in when you laid down the chain-lines, offsets, &c.

3. The most expeditious method of laying down crooked fences is by means of an offset scale, which must be used with the plotting-scale in the following manner: Lay one edge of the plotting-scale close by the base-line, and bring the end of the offset-scale in contact with the edge of the plotting-scale, so that the edges of the scales may form a right angle; then by the edge of the offset-scale prick off, in its proper situation, the first offset, with a pencil finely pointed. Keep the plotting-scale firm, and slide the offset-scale to the place of the next perpendicular, which prick off as before; and thus proceed until all the offsets are finished.

4. Properly prepared lead pencils, of different degrees of hardness, for the use of engineers, architects, land-surveyors, and artists, are always in high repute among draftsmen. For land-surveyors they should bear pointing well, so as to produce fine lines.

### TO COMPUTE THE CONTENTS.

After the whole survey is laid down, practical surveyors straighten the crooked fences of each field, as directed in Part IV. ; and then divide the fields into trapeziums and triangles, and take such dimensions by the scale as are necessary to find the separate area of each field. They then collect all the areas into one sum; afterward find the area of the whole survey, as if it were a single field, and if it appears to be equal, or nearly equal, to the sum of the separate areas, previously found, they justly infer that their survey is correct.

NOTE 1. Those who do not approve of finding the area by the method of casting, may make use of the offsets taken in the survey, where convenient; and if more be wanted, they may be measured by the scale; for in measuring a number of small parts by it, some will probably be taken a little too large and others a little too small, so that, in the end, they will nearly counterbalance each other.

2. Practical surveyors generally lay down their lines by a scale of 4 chains to an inch, when their surveys are very large; and in computing the contents, they measure the bases and diagonals by the same scale, but the perpendiculars by a scale of 2 chains to an inch; consequently, the product of the base and perpendicular of a triangle will be its area. To treat small surveys, in a similar manner, by a scale of 2 chains and of 1 chain to an inch, must, of course, be correct.

3. When the survey is not very large, the content of each field may be set down in some convenient place upon the plan. In other cases, it may be entered within the field itself. Some gentlemen, however, prefer having the areas of their estates given in a book of particulars, containing numbers, or letters of reference, corresponding to those upon the plan.

4. As some surveyors prefer a parallel ruler to a lantern horn, or a bow of whalebone and silk, for reducing crooked fences to straight ones, I have in the following problems given the method of using that instrument.

5. When there are no dimensions given in the following problems, the figures may be measured by a scale, and then laid down in the learner's book; after which

the operations by the parallel ruler may be performed. Or, for practice, figures may be made at pleasure; and the necessary equalising lines drawn, according to the subsequent directions.

## THE USE OF THE PARALLEL RULER

IN REDUCING CROOKED FENCES TO STRAIGHT ONES, IN ORDER TO FIND THE AREAS OF FIELDS BY THE METHOD OF CASTING.

### PROBLEM I.

*To draw a right line AD from the point A through the line BC, so that the quantities on each side of the line AD may be equal.*

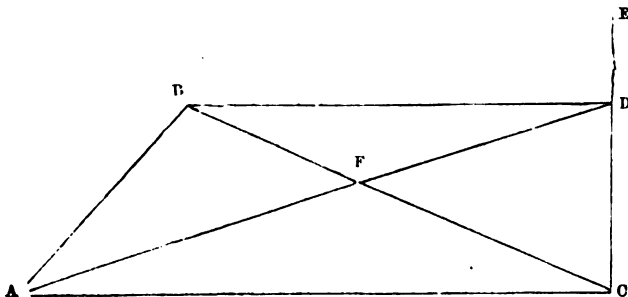

Draw with your pencil a temporary line CE, at pleasure; then, your ruler being closed, lay it from C to A; hold the side that is next to you fast; open the other to B; make a mark with your pencil upon the temporary line CE, where the edge of the ruler cuts that line, as at D; draw a line from A to D, and the quantities on each side of this line will be equal; that is, the triangle ABF will be equal to the triangle CDF.

#### *Demonstration.*

Draw the line AC, and also the line BD, which is evidently parallel to AC; then by Theo. VI., Part I., the triangle ABC is equal to the triangle ACD; take away the triangle ACF, which is common to both, and there remains the triangle ABF equal to the triangle CDF.

NOTE 1. The solutions of all the following problems are founded upon the foregoing demonstration.

2. If it had been required to draw the equalising line from the angle C, through the line AB, the temporary line must have been made from the angle A.

3. All the operations must be performed with the utmost care and accuracy; and if, at any time, the ruler be suffered to slip, the work must be repeated, or it will not be correct.

4. When an error has been committed, it may be frequently discovered by the eye, after the equalising line is drawn.

### PROBLEM II.

*Let the irregular figure ABCDEA represent an offset taken in surveying a field; it is required to draw a right line from the angle A, so as to reduce the figure to a right-angled triangle.*

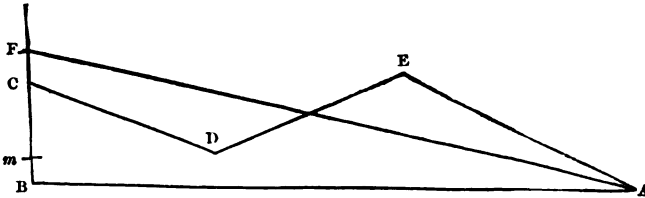

Produce the perpendicular BC for a temporary line.

Lay your ruler from C to E; bring it down in a parallel position to D; and make a mark upon the line BC, where the edge of the ruler intersects that line, as at *m*.

Lay your ruler from *m* to A; move it in a parallel direction to E, and make a mark upon the line BC, close by the edge of the ruler, as at F.

Draw a line from A to F; and the triangle ABF will be equal to the irregular figure ABCDEA; hence the area may be found by multiplying the base AB by half the perpendicular BF.

NOTE 1. In practical operations, the equalising and temporary lines must be made with a pencil finely pointed, and effaced with india-rubber, after the area is found.

2. If perpendiculars be let fall from the angles E and D, upon the base AB, the necessary dimensions taken by a scale, and the area of the irregular figure ABCDEA obtained by the rules for triangles and trapezoids, it will be found equal to the area of the right-angled triangle ABF: great care, however, must be used to make the lines very fine, and to take the dimensions of all the figures with the utmost accuracy.

### PROBLEM III.

*It is required to reduce the offset 1 2 3 4 5 to a right-angled triangle by drawing an equalising line from the fifth angle through the irregular fences.*

Perpendicularly to the base, and from the first angle, draw a temporary line.

Lay your ruler from the first to the third angle, move it in a parallel position to the second angle, and mark the temporary line at number 1.

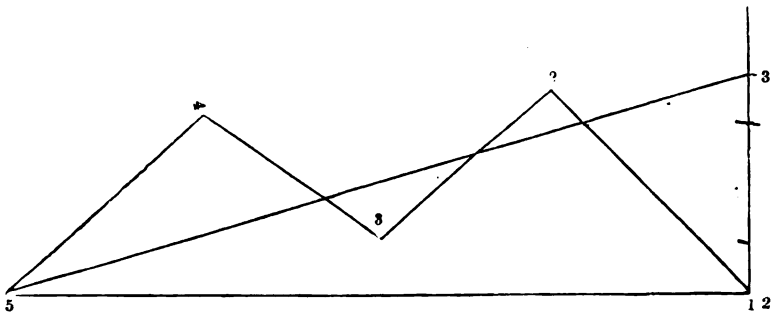

Lay your ruler from number 1 to the fourth angle, bring it down in a parallel direction to the third angle, and mark the temporary line at number 2.

Lay the ruler from number 2 to the fifth angle, move it parallel to the fourth angle, and mark the temporary line at number 3.

Draw a line from the fifth angle to number 3; and 5 1 3 will be the right-angled triangle required; hence the area of the irregular offset may be found by multiplying the base 1 5 by half the perpendicular 1 3.

PROBLEM IV.

*It is required to lay down a right-line offset from the following dimensions; to reduce it to a scalene triangle by the parallel ruler; and to find its area both by the method of offsets and casting.*

	AL	
	1500	0
H	1100	300 K
F	800	100 G
D	500	200 E
B	100	150 C
	000	0
From	A go	West

Having laid down the figure, produce the side AC, at pleasure, for a temporary line.

Lay the ruler from the first angle A to the third angle E, move it parallel to the second angle C, and mark the temporary line at 1, which, in this case, is at the second angle, because AC produced is the temporary line.



Lay the ruler from 1 to the fourth angle G, move it parallel to the third angle E, and mark the temporary line at 2.

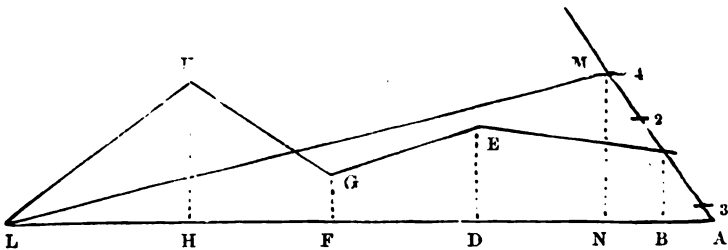

Lay the ruler from 2 to the fifth angle K, move it parallel to the fourth angle G, and mark the temporary line at 3.

Lay the ruler from 3 to the sixth angle L, move it parallel to the fifth angle K, and mark the temporary line at 4.

Draw a line from the sixth angle L to number 4 (M), and ALM will be the scalene triangle required.

*Computation of the Area by Offsets.*

Here  $150 \times 100 = 15000$ , twice the area of the triangle ABC;  $150 + 200 \times 400 = 350 \times 400 = 140000$ , twice the area of the trapezoid BDEC;  $200 + 100 \times 300 = 300 \times 300 = 90000$ , twice the area of the trapezoid DFGE;  $100 + 300 \times 300 = 400 \times 300 = 120000$ , twice the area of the trapezoid FHKG; and  $400 \times 300 = 120000$ , twice the area of the triangle HLK; then  $15000 + 140000 + 90000 + 120000 + 120000 = 485000$ , twice the area of the whole offset; and  $485000 \div 2 = 242500$  square links = 2A. 1R. 28P. the area required.

*Computation of the Area by Casting.*

From the angle M let fall the perpendicular MN, which you will find to measure 323 links; then  $\frac{323 \times 1500}{2} = \frac{484500}{2} = 242250$  sq. links = 2A. 1R. 27·6P. the area required. It differs only four-tenths of a perch from the area found by offsets.

PROBLEM V.

Lay down a curve line offset from the following dimensions; reduce it to a right-angled triangle by the parallel ruler; and find its area both by equidistant ordinates and casting.

	AN	
0	1200	
M 190	1000	L
K 260	800	H
G 270	600	F
E 250	400	D
C 180	200	B
0	000	
From	A go	East

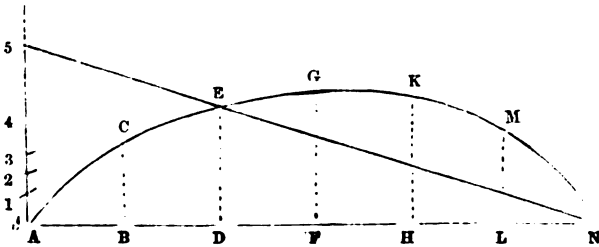

Having laid down the figure, erect the perpendicular AP for a temporary line.

Lay the ruler from A to E, move it parallel to C, and mark the temporary line at 1.

Lay the ruler from 1 to G, move it parallel to E, and mark the temporary line at 2.

Lay the ruler from 2 to K, move it parallel to G, and mark the temporary line at 3.

Lay the ruler from 3 to M, move it parallel to K, and mark the temporary line at 4.

Lay the ruler from 4 to N, move it parallel to M, and mark the temporary line at 5.

Draw a line from N to 5 (P), and NAP will be the right-angled triangle required.

*Computation of the Area by equidistant Ordinates.*

*See Prob. IX. Part III.*

Here the sum of the first and last ordinates is nothing ;  $(180 + 270 + 190) \times 4 = 640 \times 4 = 2560$ , four times the sum of the even ordinates ; and  $(250 + 260) \times 2 = 510 \times 2 = 7020$  twice the sum of the odd ordinates ; then  $\frac{2560 + 1020 + 200}{3}$

$$= \frac{3580 \times 200}{3} = \frac{71600}{3} = 238666 \text{ square links} = 2\text{A. } 1\text{R. } 21\cdot8\text{P.}$$

the area required.

M

*Computation of the Area by Casting.*

Measure the perpendicular AP, which you will find to be 398 links ;  
 then  $\frac{398 \times 1200}{2} = \frac{477600}{2} = 238800$  square links = 2A. 1R. 22P,  
 the area required ; which differs only two-tenths of a perch from that  
 found by equidistant ordinates.

## PROBLEM VI.

*It is required to reduce the following curve-line offset area to a right-angled triangle by the parallel ruler.*

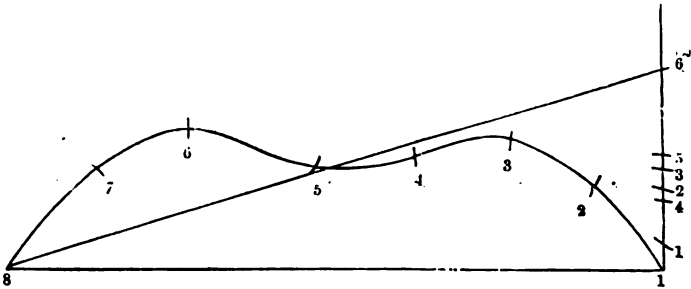

Erect a perpendicular at one end of the base for a temporary line, and assume a competent number of points in the curve to denote angles.

Lay the ruler from 1 to 3, move it parallel to 2, and mark the temporary line at 1.

Lay the ruler from 1 to 4, move it parallel to 3, and mark the temporary line at 2.

Lay the ruler from 2 to 5, move it parallel to 4, and mark the temporary line at 3.

Lay the ruler from 3 to 6, move it parallel to 5, and mark the temporary line at 4.

Lay the ruler from 4 to 7, move it parallel to 6, and mark the temporary line at 5.

Lay the ruler from 5 to 8, move it parallel to 7, and mark the temporary line at 6.

Draw a line from 8 to 6, and 8 1 6 is the triangle required ; hence the area of the irregular offset may be found by multiplying the base 1 8 by half the perpendicular 1 6.

NOTE.—When a curve-line offset area has to be reduced to a triangle by the parallel ruler, a competent number of points must be assumed in the curve, to denote angles. These points must be taken at such distances from each other that a right line drawn between any two adjacent points would *nearly* coincide with the curve.

PROBLEM VII.

*It is required to reduce the irregular figure ABCDEFGHK to a triangle by the parallel ruler.*

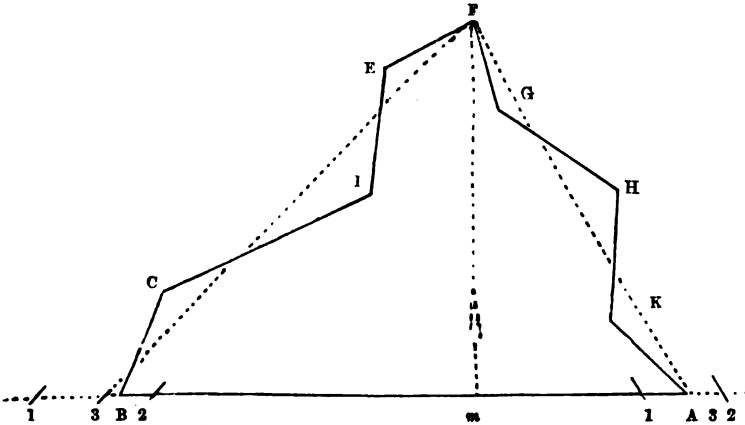

Produce the base AB both ways, at pleasure, for a temporary line.

Lay the ruler from A to H, move it parallel to K, and mark the temporary line at 1.

Lay the ruler from 1 to G, move it parallel to H, and mark the temporary line at 2.

Lay the ruler from 2 to F, move it parallel to G, and mark the temporary line at 3.

Draw a line from F to 3, and it will be a side of the required triangle.

Again, lay the ruler from B to D, move it parallel to C, and mark the temporary line at 1.

Lay the ruler from 1 to E, move it parallel to D, and mark the temporary line at 2.

Lay the ruler from 2 to F, move it parallel to E, and mark the temporary line at 3.

Draw a line from F to 3, and 3 F 3 will be the triangle required ; hence the area of the irregular figure ABCDEFGHK may be found by multiplying the base 3 3 by half the perpendicular Fm.

**NOTE.**—The method of reducing fields of four or five sides to triangles of equal areas may be seen in Problems XVI. and XVII. Part I.

## PROBLEM VIII.

*It is required to reduce the figure ABCDEFGHKL MN to a triangle by the parallel ruler.*

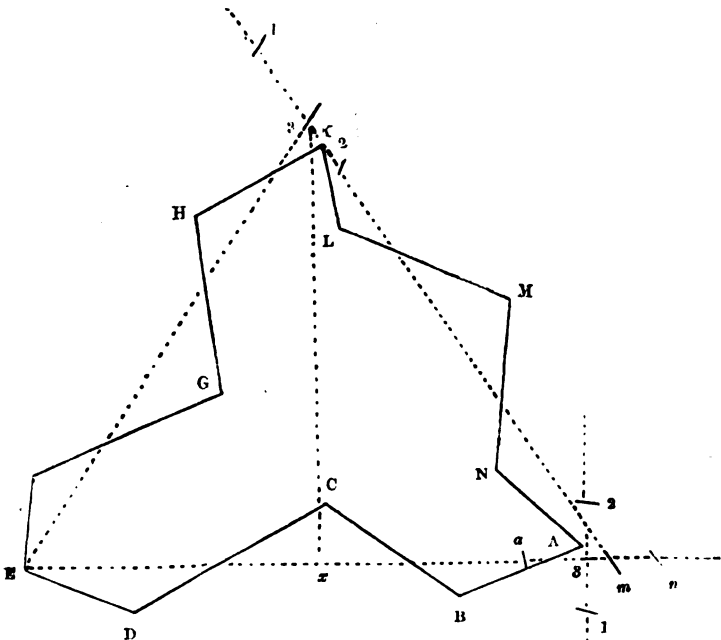

Draw the temporary line 1 2 to touch the angle A.

Lay the ruler from A to C, move it parallel to B, and mark the temporary line at 1.

Lay the ruler from 1 to D, move it parallel to C, and mark the temporary line at 2.

Lay the ruler from 2 to E, move it parallel to D, and mark the temporary line at 3.

Draw a line from E to 3, and produce it, at pleasure, for a temporary line.

Lay the ruler from 3 to M, move it parallel to N, and mark the temporary line at a.

Lay the ruler from a to L, move it parallel to M, and mark the temporary line at n.

Lay the ruler from n to K, move it parallel to L, and mark the temporary line at m.

Draw a line from  $m$  to  $K$ , and produce it, at pleasure, for a temporary line.

Lay the ruler from  $K$  to  $G$ , move it parallel to  $H$ , and mark the temporary line at 1.

Lay the ruler from 1 to  $F$ , move it parallel to  $G$ , and mark the temporary line at 2.

Lay the ruler from 2 to  $E$ , move it parallel to  $F$ , and mark the temporary line at 3.

Draw a line from  $E$  to 3, and  $E3m$  will be the triangle required; hence the area of the figure  $ABCDEFGHKLMN$  may be found by multiplying the base  $Em$  by half the perpendicular  $3x$ .

### PROBLEM IX.

*It is required to reduce the figure  $ABCDEFGHKLM$  to a trapezium by the parallel ruler.*

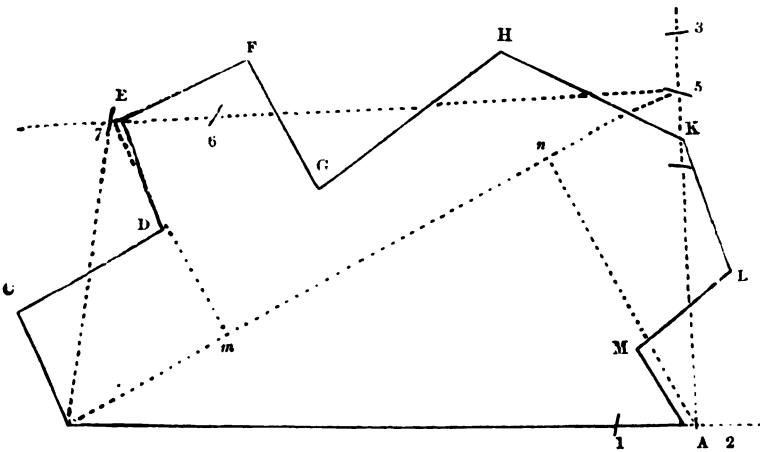

Produce the line  $AB$ , at pleasure, for a temporary line.

Lay the ruler from  $A$  to  $L$ , move it parallel to  $M$ , and mark the temporary line at 1.

Lay the ruler from 1 to  $K$ , move it parallel to  $L$ , and mark the temporary line at 2.

Draw a line from 2 to  $K$ , and produce it, at pleasure, for a temporary line.

Lay the ruler from  $K$  to  $G$ , move it parallel to  $H$ , and mark the temporary line at 3.

Lay the ruler from 3 to  $F$ , move it parallel to  $G$ , and mark the temporary line at 4.

Lay the ruler from 4 to E, move it parallel to F, and mark the temporary line at 5.

Draw a line from 5 to E, and produce it, at pleasure, for a temporary line.

Lay the ruler from E to C, move it parallel to D, and mark the temporary line at 6.

Lay the ruler from 6 to B, move it parallel to C, and mark the temporary line at 7.

Draw a line from 7 to B, and B 7 5 2 will be the trapezium required; hence the area of the figure ABCDEFGHKLM may be found by multiplying the diagonal B 5 by half the sum of the two perpendiculars 7 *m* and 2 *n*.

### PROBLEM X.

*It is required to reduce the figure ABCDEFGHKLMNPR to a trapezium by the parallel ruler.*

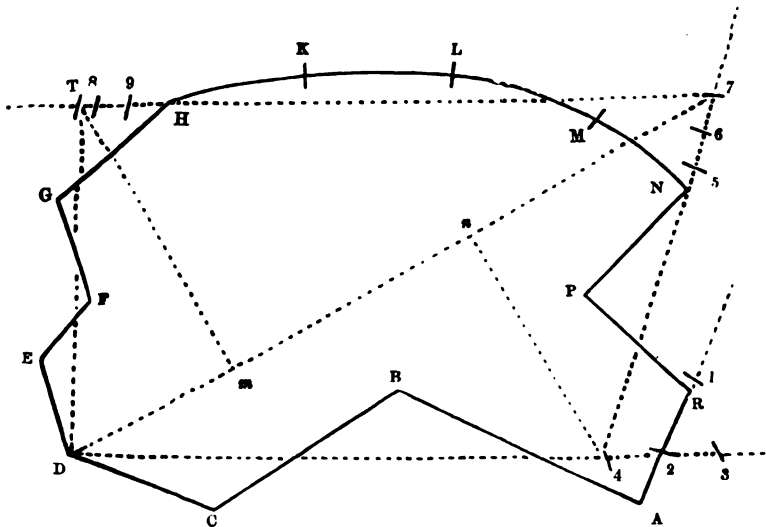

Continue AR for a temporary line.

Lay the ruler from A to C, move it parallel to B, and mark the temporary line at 1.

Lay the ruler from 1 to D, move it parallel to C, and mark the temporary line at 2.

Draw a line from D to 2, and produce it, at pleasure, for a temporary line.

Lay the ruler from 2 to P, move it parallel to R, and mark the temporary line at 3.

Lay the ruler from 3 to N, move it parallel to P, and mark the temporary line at 4.

Draw a line from 4 to N, and produce it, at pleasure, for a temporary line.

Lay the ruler from N to L, move it parallel to M, and mark the temporary line at 5.

Lay the ruler from 5 to K, move it parallel to L, and mark the temporary line at 6.

Lay the ruler from 6 to H, move it parallel to K, and mark the temporary line at 7.

Draw a line from 7 to H, and produce it, at pleasure, for a temporary line.

Lay the ruler from H to F, move it parallel to G, and mark the temporary line at 8.

Lay the ruler from 8 to E, move it parallel to F, and mark the temporary line at 9.

Lay the ruler from 9 to D, move it parallel to E, and mark the temporary line at T.

Draw the line DT, and D T 7 4 will be the trapezium required ; hence the area of the irregular figure may be found by multiplying the diagonal D 7 by half the sum of the two perpendiculars  $Tm$  and  $4n$ .

### PROBLEM XI.

*It is required to draw an equalising line, by the parallel ruler, through the crooked fence ABCDE, so that the two fields which it separates may be reduced to trapeziums.*

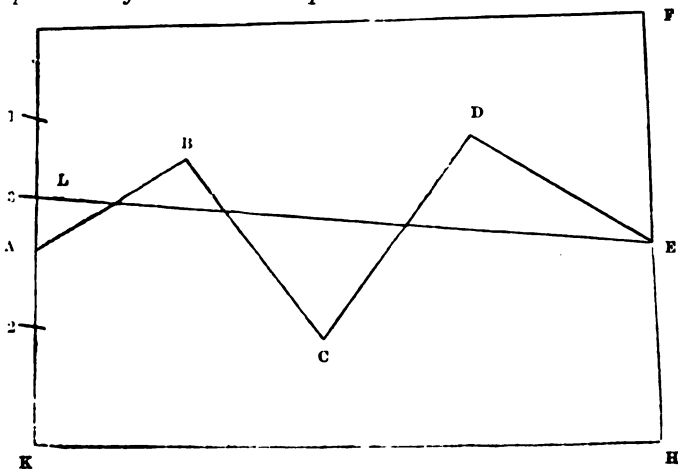



Lay the ruler from A to C, move it parallel to B, and mark the temporary line in KG at 1.

Lay the ruler from 1 to D, move it parallel to C, and mark the temporary line at 2.

Lay the ruler from 2 to E, move it parallel to D, and mark the temporary line at 3.

Draw a line from E to 3 (L), and the irregular figure ABCDEFG will be reduced to the trapezium LEFG, and the irregular figure ABCDEHK to the trapezium LEHK; hence their respective areas may be obtained by measuring diagonals and perpendiculars.

NOTE 1. Sometimes the proprietors of adjoining estates agree to straighten crooked fences or brooks by *giving* and *taking* equal quantities of land. When this is the case, you must first measure and plan the ground, then draw the equalising line as directed in the last problem, and take the distance from A to L very correctly by the scale. Measure this distance in the field from the angle A; range the division line E L, and stake it out; and the work will be completed.

2. It will be advisable to measure, both on the plan and in the field, the parts cut off on each side by the division-line, in order to prove the work; for an error committed in dividing land is of serious consequence, if it be not discovered and rectified before the new fence is made.

## PROBLEM XII.

*It is required to draw an equalising line by the parallel ruler, so that the curved fence which separates the two fields in the following figure may be reduced to a straight fence.*

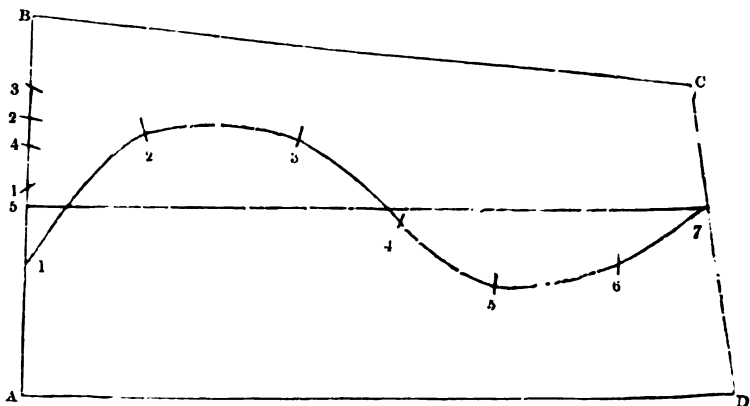

Lay the ruler from 1 to 3, move it parallel to 2, and mark the temporary line in AB at 1.

Lay the ruler from 1 to 4, move it parallel to 3, and mark the temporary line at 2.

Lay the ruler from 2 to 5, move it parallel to 4, and mark the temporary line at 3.

Lay the ruler from 3 to 6, move it parallel to 5, and mark the temporary line at 4.

Lay the ruler from 4 to 7, move it parallel to 6, and mark the temporary line at 5.

Draw a line from 7 to 5, and it will reduce the figure ABCD to two trapeziums ; hence their respective areas may be found by measuring diagonals and perpendiculars.

---

*The following general rule for the parallel ruler will be found of considerable service to learners, and may be easily committed to memory.*

#### GENERAL RULE.

1. Lay the ruler from the first to the third angle, move it parallel to the second angle, and you will have the first mark on the temporary line.

2. Lay the ruler from the first mark on the temporary line to the fourth angle, move it parallel to the third angle, and you will have the second mark on the temporary line.

3. Lay the ruler from the second mark on the temporary line to the fifth angle, move it parallel to the fourth angle, and you will have the third mark on the temporary line.

4. Lay the ruler from the third mark on the temporary line to the sixth angle, move it parallel to the fifth angle, and you will have the fourth mark on the temporary line.

5. Lay the ruler from the fourth mark on the temporary line to the seventh angle, move it parallel to the sixth angle, and you will have the fifth mark on the temporary line.

6. Lay the ruler from the fifth mark on the temporary line to the eighth angle, move it parallel to the seventh angle, and you will have the sixth mark on the temporary line.

7. Lay the ruler from the sixth mark on the temporary line to the ninth angle, move it parallel to the eighth angle, and you will have the seventh mark on the temporary line.

8. Lay the ruler from the seventh mark on the temporary line to the tenth angle, move it parallel to the ninth angle, and you will have the eighth mark on the temporary line, &c.

NOTE.—As the operations of the parallel ruler, in straightening crooked fences, are founded upon a mathematical truth, it is preferable to a lantern horn ; but

the latter may be applied with much more expedition than the former; and if it be used by a skilful hand, its results will be sufficiently correct for general practice. (See Problems I. and II. Part IV.)

A BOOK OF DIMENSIONS, CASTINGS, AND AREAS  
BELONGING TO PLATE VIII.

Names of Proprietors	No. on the plan.	Diagonals.	First Perpend.	Second Perpen.	Sum of Perpend.	Quantity in A. dec.	Quantity in A. R. P.
Mr Dalton's Close	1	625	180	—	180	1·12500	1 0 20
Mr Cayley's Close	2	916	52	247	299	2·73884	2 2 38
Mr Whisker's Close	3	742	123	155	278	2·06276	2 0 10
Mr Straker's Close	4	2094	160	481	641	13·42254	13 1 28
Mr Straker's Close	5	1855	328	268	596	11·05580	11 0 9
Mr Ellard's Close	6	2197	574	—	574	12·61078	12 2 18
Whole quantity						43·01572	43 0 3

**NOTE 1.** In the first edition of this work, the content of the estate in Plate VIII. was found from a plan of 2 chains to an inch. The bases, diagonals, and perpendiculars were measured by the scale used in planning; the offsets taken in the field were used where convenient, and when those were insufficient, more were measured by the scale. In this edition, the crooked fences have been straightened by the parallel ruler, the bases and diagonals measured by a scale of 2 chains to an inch, and the perpendiculars by a scale of 1 chain to an inch; hence the area of each triangle was found by multiplying the base by the perpendicular, and the area of each trapezium by multiplying the diagonal by the sum of the two perpendiculars.

The diagonals, perpendiculars, and areas are entered in the foregoing Book of Castings; and it may also be observed that the bases of triangles are put down in the column of diagonals, and their perpendiculars in the first column of perpendiculars.

2 In straightening crooked fences by the parallel ruler, it frequently happens that one equalising line will serve for two adjoining fields; and almost every irregular figure may be reduced either to a triangle or a trapezium. (See Problems XVI. and XVII. Part 1.; and also the Use of the Parallel Ruler, Part V.)

## A BOOK OF DIMENSIONS, CASTINGS, AND AREAS

BELONGING TO PLATE X.

Names of the Fields	No. on the Plan.	Diagonals.	First Perpend.	Second Perpend.	Sum of Perpend.	Quantity in A. dec.	Quantity in A. R. P.		
Grime Garth .	1	1166	265	95	360	4·19760	4	0	32
House Ing. .	2	1581	440	—	440	6·95640	6	3	33
Sandy Field .	3	1098	196	97	293	3·21714	3	0	35
Low Holme .	4	861	259	88	347	2·98767	2	3	38
Brook Close .	5	1130	215	—	215	2·42950	2	1	29
Low Close .	6	969	243	—	243	2·35467	2	1	17
Marsh Close .	7	1209	336	—	336	4·06224	4	0	10
Green Meadow	8	846	153	200	353	2·98638	2	3	38
Horse Pasture	9	741	161	170	331	2·45271	2	1	32
Cow Pasture .	10	962	150	104	254	2·44348	2	1	31
Calf Garth .	11	725	180	133	313	2·26925	2	1	3
Long Meadow	12	1781	226	224	450	8·01450	8	0	2
River Close .	13	810	178	174	352	2·85120	2	3	16
Primrose Close	14	1046	183	210	393	4·11078	4	0	18
Bridge Ing. .	15	1733	287	153	440	7·62520	7	2	20
Shady Ing. .	16	875	159	187	346	3·02750	3	0	4
Hare Park. .	17	880	147	167	314	3·76320	2	3	2
Long Tongue	18	1092	284	—	284	3·10128	3	0	16
Whole quantity						67·85070	67	3	16

NOTE.—In the first edition of this work, the content of the estate in Plate X. was found from a plan of 2 chains to an inch, by making the crooked fences straight by a lantern horn, as directed in Part IV. In this edition, all the crooked fences have been straightened by the parallel ruler, the bases and diagonals measured by a scale of 2 chains to an inch, and the perpendiculars by a scale of 1 chain to an inch; and hence the foregoing Book of Dimensions, Castings, and Areas was formed.

## TO TRANSFER A ROUGH PLAN

TO A CLEAN SHEET OF PAPER, OR TO A SKIN OF PARCHMENT OR VELLUM, IN ORDER TO MAKE A FINISHED PLAN ; ALSO TO ENLARGE OR REDUCE PLANS, ETC.

### METHOD I.

#### *y Points.*

Having laid the fresh sheet upon a smooth table, lay the rough plan upon it, and with four small nails (or weights or books) fasten the corners of both to the table. Then, with your pricker, pierce the extremities of straight lines, and as much of the curved ones as will enable you to draw them on the new plan. Next separate the papers, and trace the outlines and fences with a black-lead pencil, after which draw them with a fine pen and good Indian ink.

NOTE.—Common ink ought never to be used in planning, because it not only sinks too deep into the paper, but generally, in process of time, becomes discoloured.

### METHOD II.

#### *By Tracing-Paper.*

Take a sheet of writing-paper, of the same size as the rough plan, and rub one side of it with black-lead powder ; then lay it upon the sheet which you intend for your new plan, with the black side downward ; upon both lay the rough plan, and fasten them all to the table, as before directed. Next run your tracer gently over all the lines upon the plan, so that the black-lead under them may be transferred to the fresh paper. They must then be drawn with Indian ink, as before directed.

NOTE.—This method of transferring is preferable to the former, because it does not injure the plans.

### METHOD III.

#### *By a Copying-Glass.*

A copying-glass is a large square or rectangular piece of the best window-glass, fixed in a frame of wood, which can be raised to any angle, like a desk, the lower side resting upon a table ; and a screen of blue paper may be fitted to the upper edge, and stand at right angles to it.

Place this frame at a convenient angle, against a strong light ; fix the old plan and clean paper firmly together by pins, the clean paper uppermost, and on the face of the plan to be copied ; lay them with the back of the old plan next the glass, namely, that part which you intend to copy first.

The light through the glass will enable you to perceive distinctly every line of the plan upon the clean paper, and you can easily trace over them with a pencil; and having finished that part which covers the glass, slide another part over it, and copy this, and thus continue till the whole be copied.

NOTE.—Those who have not a copying-glass may use a rectangular piece of window glass fixed in a common frame; and when copying, it may be placed in an inclining position, with its top against a window, and its bottom upon the window-seat, if it be nearly level with the bottom of the window. A pane in a window is not unfrequently used for copying small drawings.

#### METHOD IV.

##### *By Similar Squares.*

The three foregoing methods of transferring or copying plans can only be applied when the rough plan is of the same size which you wish the finished one to be; but, as it may be necessary to reduce the size of the original, this may be done by similar squares.

##### *Example.*

Suppose the following inclosures to have been laid down by a scale of 2 chains to an inch; it is required to reduce them to one of 4 chains to an inch.

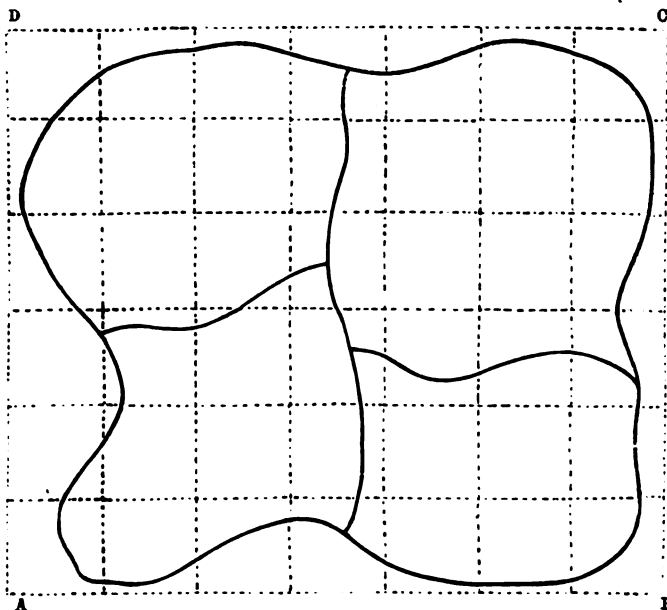

By a scale of 2 chains to an inch, draw the line  $AB = 7$  chains. At A and B erect the perpendiculars AD and BC, each of which

make = 6 chains, and join DC. Divide the lines AB and DC each into 7 equal parts, and the lines AD and BC each into 6 equal parts; join the opposite points of division, and the rectangle ABCD will be divided into 42 equal squares, the side of each being one chain.

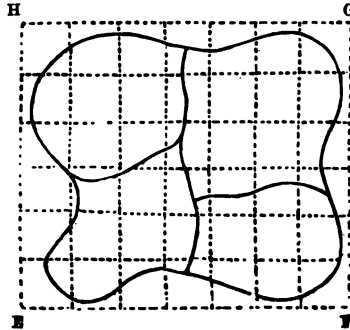

Next, by a scale of 4 chains to an inch, draw the line  $EF = 7$  chains. At E and F erect the perpendiculars EH and FG, each of which make = 6 chains, and join HG. Divide the lines EF and HG each into 7 equal parts, and the lines EH and FG each into 6 equal parts, join the opposite points of division, and the rectangle EFGH will be divided into 42 equal squares, the sides of which will be exactly half the size of those in the rectangle ABCD.

Then, with your pencil, draw within the rectangle EFGH the fences contained within the rectangle ABCD; making each fence pass through its proper situation in the corresponding squares, which may be done by observing where the lines forming the squares intersect the fences. Afterwards trace the fences with Indian ink, as before directed.

NOTE.—In copying or reducing a large plan by this method, you ought to number the corresponding squares in the circumscribing rectangles with the same figures, in order to prevent mistakes. These figures, as well as the lines forming the squares, should be made with a pencil, and effaced after the plan is copied.]

## METHOD V.

### *By the Pentagraph.*

The pentagraph is an instrument for copying, reducing, and enlarging plans. Copies of surveys are also now being taken by a method termed photozincography, but from the many improvements that are annually taking place, it is seldom that a complete copy is called for, all the changes made in roads, fences, &c., requiring to be entered in the new plan. Surveyors will therefore have chiefly to

rely upon their plotting scales, proportional compasses, &c. At the same time, much may often be done by the pentagraph, so that its use should be learned.

### DESCRIPTION OF THE PENTAGRAPH.

The pentagraph is generally made of wood or brass, from 12 inches to two feet in length, and consists of four flat bars or rulers, two of them long, and two short, as illustrated in the plate below. The two longer are joined at the end A by a double pivot, which is fixed to one of the rulers, and works in two small holes placed at

PLATE V.

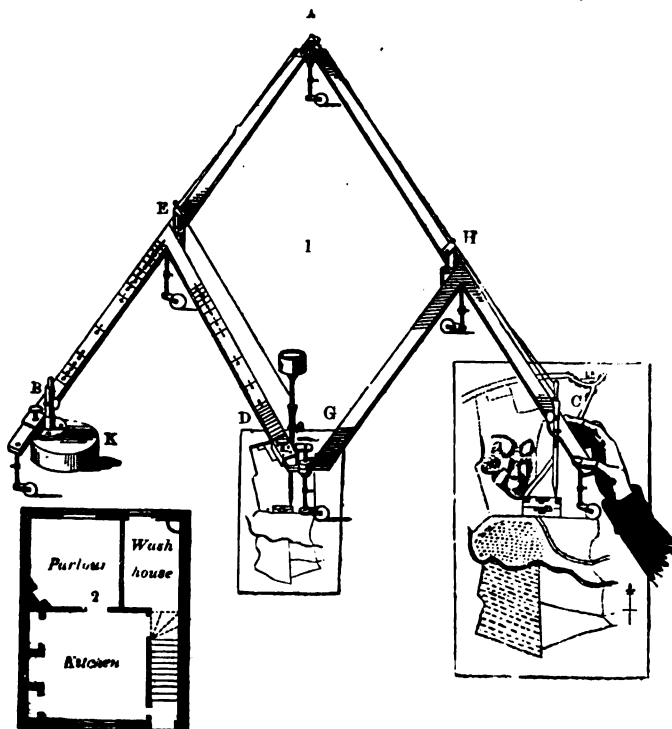

the end of the other. Under the joint is an ivory castor, to support this end of the instrument. The two smaller rulers are fixed by pivots at E and H near the middle of the larger rulers, and are also joined together at their other end G.

By the construction of this instrument, the four rulers always form



a parallelogram. There is a sliding box on the longer arm, and another on the shorter arm. These boxes may be fixed at any part of the rulers, by means of their milled screws; and each of these boxes is furnished with a cylindric tube, to carry either the tracing point, pencil, or fulcrum.

The fulcrum or support K is a leaden weight; on this the whole instrument moves when in use.

To the longer instruments are sometimes placed two moveable rollers, to support the pentagraph and facilitate its motions. Their situation may be varied as occasion requires.

The graduations are placed on two of the rulers, B and D, with the proportions of  $\frac{1}{2}$ ,  $\frac{1}{3}$ ,  $\frac{1}{4}$ , &c. to  $\frac{1}{12}$ , marked on them.

The pencil-holder, tracer, and fulcrum must in all cases be in a right line, so that when they are set to any number, if a string be stretched over them, and they do not coincide with it, there is an error either in the setting or gradations.

The long tube which carries the pencil or crayon moves easily up or down in another tube; there is a string affixed to the long or inner tube, passing afterwards through the holes in three small knobs to the tracing point, where it may, if necessary, be fastened. By pulling this string, the pencil is lifted up occasionally, and thus prevented from making false or improper marks upon the copy.

### THE USE OF THE PENTAGRAPH.

*To reduce a plan in any of the proportions,  $\frac{1}{2}$ ,  $\frac{1}{3}$ ,  $\frac{1}{4}$ ,  $\frac{1}{7}$ , &c., as marked on the two bars B and D. Suppose, for example,  $\frac{1}{2}$  is required.*

Place the two sockets, at  $\frac{1}{2}$ , on the bars B and D, the fulcrum or lead weight at B, the pencil socket with the pencil at D, and the tracing point at C. Fasten down upon a smooth board or table a sheet of white paper under the pencil D, and the original map, &c., under the tracing point C, allowing yourself room enough for the various openings of the instrument. Then with a steady hand carefully move the tracing point C over all the lines on the map; and the pencil at D will describe exactly the same figure as the original, but  $\frac{1}{2}$  the size. In the same manner for any other proportion, by setting the two sockets to the number of the required proportion.

The pencil-holder moves easily in the socket, to give way to any irregularity in the paper. There is a cup at the top for receiving an additional weight, either to keep down the pencil to the paper, or to increase the strength of its mark.

A silken string is fastened to the pencil-holder, in order that the pencil may be drawn up off the paper, to prevent false marks when crossing the original plan, in the operation.

If the original should be so large that the instrument will not extend over it at one operation, two or three points must be marked on the original, to correspond with the same upon the copy. The fulcrum and copy may then be removed into such situations as to admit the copying of the remaining part of the original; first observing, that when the tracing point is applied to the three points marked on the original, the pencil falls on the three corresponding points upon the copy. In this manner by repeated shiftings, a pentagraph may be made to copy an original of ever so large dimensions.

*To enlarge a Plan in any of the proportions  $\frac{1}{2}$ ,  $\frac{1}{3}$ ,  $\frac{1}{4}$ , &c.  
Suppose  $\frac{1}{2}$ .*

Set the two sockets at  $\frac{1}{2}$ , as before, and change places of the pencil and tracing point; namely, place the tracing point at D, and the pencil at C.

*To copy a Plan the same size as the Original.*

Place the two sockets at  $\frac{1}{2}$ , the fulcrum at D, and the pencil at B. In this case the lines upon the new plan will be reversed, in copying.

NOTE 1. There are sometimes divisions of 100 unequal parts laid down on the bars B and D, to give any intermediate proportion, not shown by the fractional numbers.

3. Pentagraphs of a greater length than two feet are best made of hard wood mounted in brass, with steel centres, upon the truth of which depends entirely the equable action of this useful instrument.

3. Though I have given various methods of reducing plans, I would advise the learner, after he has found the contents from a plan of 2 chains, or of 1 chain to an inch, to draw another rough plan, of the same size which he intends his finished one to be; and then to transfer it to a clean sheet by any of the foregoing methods. This may appear a little tedious, but it will make the learner very expert in laying down his lines, which will be found of great advantage to him, when he enters upon the Practical Part of Surveying.

## TO EMBELLISH A PLAN.

In order to make a neat, finished plan, some knowledge of drawing is absolutely necessary. The learner should also be a proficient in plain and ornamental penmanship; or he will not be able to finish a plan either with beauty or elegance. Every person who would excel in this art, should devote all his leisure hours to copying and making out drawings, either from plans or copper-plates well executed, as nothing but practice will make a good draughtsman.

## METHOD I.

*Plans neatly finished with Indian Ink and Colours.*

Having transferred the plan to a clean sheet of drawing-paper, or to a skin of parchment or vellum, by any of the foregoing methods, draw all the straight lines very finely, by the edge of a ruler, with a drawing-pen and Indian ink ; but the curved lines must be drawn by a steady hand.

Proceed next to make the representation of hedges, bushes, trees, woods, gates, stiles, bridges, the bases of buildings, &c. &c. in their proper places ; running a single dotted line, in an open field, for a foot-path, and a double one for a carriage-road.

Hills may be shaded with a brush or hair-pencil and Indian ink. The first wash should be weak, and the edges of the shade, particularly at the top and bottom of a hill, must be softened off with clear water, and a clean brush, kept for that purpose, at one end of the pencil-handle ; the other end being occupied by the Indian ink brush.

When the hills are very steep, and rise one above another, as those in Wales, Derbyshire, Yorkshire, Westmoreland, Cumberland, Northumberland, and Scotland, they must all be shaded according to their various inclinations ; always letting one wash dry before another is laid on, and never neglecting to soften off the edges of each shade with water.

If some parts of the hills be rocky, tint them with a colour resembling stone, after they have been shaded with Indian ink and a hair-pencil in the manner exhibited in No. 2, Plate VII.

It may also be observed that when the inclination of a hill is inconsiderable, it is never noticed by surveyors, in shading or finishing their plans, and if hills be flat at the top, they are left nearly white.

The method of shading high moorish ground and hilly fields may be seen in Plates VI. and VII. ; except they must not be done with lines, in imitation of engraving, but with repeated washes of Indian ink.

After hills have been properly shaded with Indian ink, they may then be coloured in the manner hereafter directed for meadow, pasture, and arable land.

Lakes, rivers, brooks, &c. may also be shaded with a brush and Indian ink, pretty strongly at the edges, and softened off towards the middle ; and when they are dry, they may be washed over with a light tint of Prussian blue. The shape of arrows should also be made in brooks and rivers, to show in what direction the streams run.

Meadow and pasture ground should be coloured with a transparent green, the pasture rather lighter than the meadow ; arable land with various shades of fine brown, so that too many fields may not appear exactly alike ; and some surveyors use both red, blue, lake, and yellow in colouring plans.

If the quickwood hedges be not made with a pen and Indian ink, in imitation of bushes, they may be represented by running narrow shades of colouring along the black lines which form the boundaries of the different enclosures.

Roads should be washed with a brownish tint, and the bases of buildings with a red one, or with Indian ink, laid on with a brush of a convenient size, as it is difficult to manage large brushes in shading small spaces.

Sands upon the sea-shore may be washed over with a mixture of brown, lake, and gamboge.

Greens of various shades may be composed of blue and yellow ; a pleasing variety of brownish tints may be produced by mixing lake, red, or yellow, with a little brown ; and a shade for water may be formed of Indian ink and Prussian blue.

All the washes should be made thin and laid on in a very neat manner, as nothing disfigures a plan or map so much as daubing on the colours too thickly.

If the estate be small, the area of each enclosure may be put down in some vacant part of the plan ; but if it be large, the areas must either be entered within the fields themselves, or in a book of particulars, which may also contain any remarks that the surveyor may think necessary to make to his employer concerning the estate.

In some convenient parts of the plan, write, in various hands, with Indian ink, the title of the estate, ornamented with a compartment or device. In another vacancy introduce the scale by which the plan has been laid down, and also meridian-line, with the compass or flower-de-luce pointing to the north.

The whole may then be bordered with black lines, at a convenient distance from each other, and the space between them shaded with a hair-pencil and Indian ink. See Plates IX. and XI.

**NOTE 1.** If the learner examine a well-finished coloured map of England, or any other country, he will fully comprehend what has been said on the subject of embellishing plans.

2. Indian ink must always be used in planning ; and as it is frequently of a very bad quality, it is advisable to try it before you purchase, by wetting one end of the cake, and rubbing it upon white paper. The blackest and freest is considered the best.

3. The most convenient colours are those ready prepared in cakes, which must be used in the following manner : Dip one end of the cake in clear water, and rub

a little of it upon a clean wedgewood or earthen plate ; then mix it with water by your hair-pencil, until you have brought it to any consistency you please. Indian ink must be prepared for use in the same way.

4. The following water-colours may be enumerated ; viz. :—

Vandyke Brown.	Yellow Ochre.	Vermilion.
Raw Sienna.	Indian Yellow.	Prussian Blue.
Burnt Sienna.	Light Red.	Prussian Green.
Gamboge.	Lake.	Sap Green.

By means of these colours a great variety of tints may be formed ; and a little practice will soon enable the learner to produce any shade that may be wanted for plans or maps.

5. When the price for measuring and planning is *very small*, surveyors generally finish their plans neatly, but without either colours, compartments, or embellishments of any kind.

6. Professional surveyors always enter in their field-books the day of the month and date of the year when they begin to survey an estate ; and in finishing their plan, they date them accordingly, and also insert their own names, in order that gentlemen may know when and by whom their estates were surveyed.

## METHOD II.

### *Plans highly finished with Indian Ink and Colours.*

The foregoing method of finishing plans is very expeditious, and may suffice when the price allowed for surveying will not admit of much time being spent in making embellishments ; but when a highly-finished plan is wanted, the following method must be adopted.

#### *Meadows.*

With a pen, or a very fine-pointed hair-pencil, and light Indian ink, make perpendicular and inclining strokes over the whole meadow, as represented in No. 1, Plate VI., and then wash it with a fine transparent green. The strokes must be of various lengths, but none of them should exceed the 10th part of an inch.

#### *Pasture Grounds.*

Pastures may be shaded with upright and sloping strokes, of various lengths, as represented in No. 2, Plate VI., and then washed over with a green, somewhat inclining to yellow. None of the strokes should exceed the 20th part of an inch in length.

#### *Corn Fields.*

By the edge of a ruler, or by the hand, draw (in short dishes) fine parallel lines, at equal distances from each other, so as to give the fields the appearance of being divided into ridges and furrows, as represented in Nos. 3 and 4, Plate VI. ; and then wash each field over with a different tint of brown, inclining to yellow.

PLATE VI.

1. *Meadow.*

2. *Pasture.*

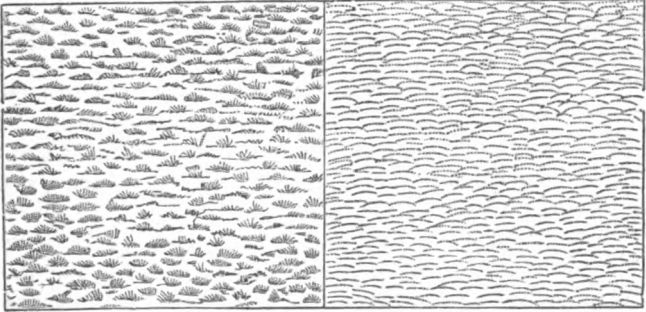

3. *Corn Field.*

4. *Corn Field.*

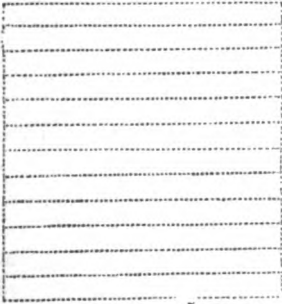

5. *High Moorish Ground.*

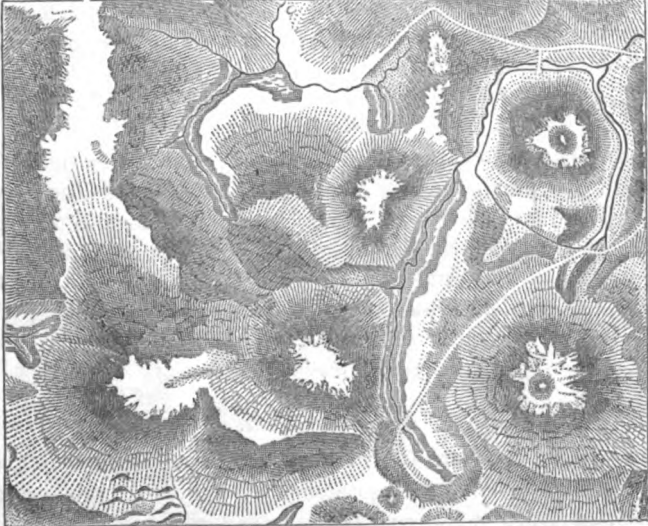

Corn fields neatly finished in this manner give a plan a very fine appearance.

#### *Moors.*

With a pen, or a hair-pencil, draw the representation of a few scattered hillocks if there be any on the moor.

Draw also here and there small bushes, to represent heath, broom, whins, and such like brushwood as usually grow upon moors.

Make likewise tufts of grass, if the moor is pasturable, and then fill up all the vacant spaces with perpendicular and inclining strokes, as represented in Nos. 1 and 2, Plate VI.

If the moor be high, hilly, and rugged, with pools of water, caverns, roads, &c., it must be shaded with lines, in imitation of engraving, as exhibited in No. 5, Plate VI.; if any parts be wet and marshy, they must be done in the same manner as marshy ground; and if the moor contains large stones, rocks, or trees, they must not be omitted.

When you have finished shading with Indian ink, you must then colour the different parts of the moor in the same manner as they appear in nature. The parts producing herbage must be washed with a greenish colour, inclining to blue; the dark parts with a brownish tint; the lighter parts with a yellowish one, &c.; and the shrubs and bushes may be touched up with a fine lightish green.

If the moor contains whins, first wash them with green, and then touch them up on the west side with yellow, which will give them the appearance of being in blossom.

By proceeding as above directed, a variety of pleasing effects and shades will be produced, and you will be able to give your plan a very fine appearance, and make it resemble even nature itself.

#### *Marshy Ground.*

With a pen, or a fine-pointed hair-pencil, and palish Indian ink, draw, by the hand, shortish horizontal strokes of various lengths, pretty closely to each other. Make also the representation of reeds, rushes, sedges, and strong herbage, as exhibited in No. 1, Plate VII.; wash the whole over with a palish green, inclining to blue; and then touch up the reeds, rushes, sedges, &c. with a stronger green, which soften off either towards the right or left with a lighter one, or with clear water. (See the Method of Shading Trees.)

#### *Sands and Rocks.*

Sands on the sea-shore, &c., must be represented by small dots, with a pen and Indian ink; loose stones by figures resembling small circles and ovals, but more irregular; and rocks must be made to

PLATE VII.

1. *Marshy Ground.*

2. *Sands and Rocks.*

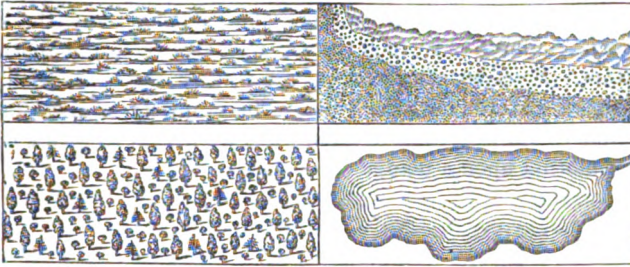

3. *Trees.*

4. *Water.*

5.

*Hilly Fields.*

6.

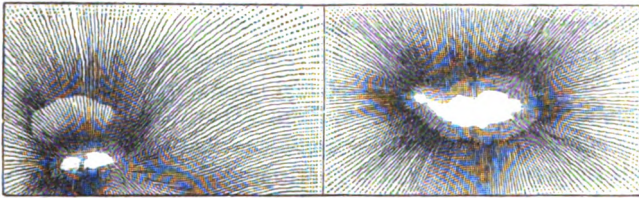

7. *Plan of a New Town.*

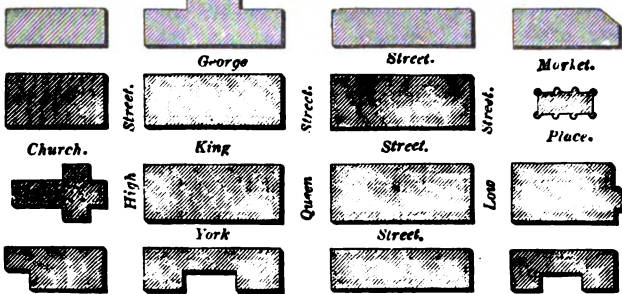

8. *Elevation of a House.*





appear rugged and rough, and to rise in succession, one above another, as exhibited in No. 2, Plate VII. The sands may then be washed over with a mixture of brown, lake, and gamboge; and the stones and rocks coloured with such tints as will give them the appearance of nature. Some stones and rocks are whitish, some yellowish, some greyish, others brownish, &c.; hence the propriety of always taking their real colour into consideration when we intend to give a faithful representation upon a plan.

### *Trees.*

Trees always adorn and beautify the face of nature, and when they are neatly drawn, with a fine pen and Indian ink, they give a plan a very beautiful and pleasing appearance.

They must be made with vertical stems, neat broadish tops, shaded darker on one side than the other, and black horizontal shades at the bottom, as represented in No. 3, Plate VII.

The lighter parts of the trees represent that side upon which the light is supposed to fall, and the horizontal shades at the bottom are intended to denote the shadows of the trees upon the ground. These shadows must always be made on the darker sides of trees, and also of every other object, where shadows are intended to be represented.

It is not material which side of a tree be left light; but we must take care to make all the trees in the same wood light on the same side; for we cannot suppose that the light can fall on the right of some trees, and on the left of others at the same time.

When a sufficient number of trees have been made to give the wood an agreeable appearance, the vacant spaces must be filled up with small bushes to represent the underwood. The whole wood should then be washed over with a lightish green; after which the tops of the largest trees may be touched up with a darker green, and with a little brown or yellow, in order to produce that pleasing variety of tints which we so often behold and admire in nature.

NOTE 1. When the Indian ink is not perfectly dry, it will run in washing the wood with green; in order to avoid this, the green wash may be laid on before the trees and bushes are made.—This observation also points out the propriety of colouring fields before the quickwood fences are made with Indian ink.

2. The tops of trees are formed in various ways. Sometimes they are made with jagged edges, and filled up in the middle with irregular strokes, in different directions, and some surveyors form them entirely by horizontal lines of various lengths.

3. When trees are small and neatly made, it is unnecessary to touch them up with any colour.

4. Quickwood hedges must be made with a pen and Indian ink, in imitation of bushes, and when trees are properly introduced, they have a very good effect in the hedgerows. (See Plates IX. and XI.)

*Lakes, Rivers, and the Sea-Shore.*

Water must first be coloured with a fine tint of Prussian blue, and then shaded by a pen and Indian ink, with crooked or waved lines, bold near the edges, and fainter towards the middle, as exhibited. in No. 4, Plate VII., which is intended to represent a mere or lake.

Rivers and brooks must also be shaded with waved lines, continued from one end to the other, as represented in Plate XI. ; and the sea-shore in a similar manner, but much stronger and bolder than either lakes or rivers.

NOTE 1. Some draughtsmen do not wash with Prussian blue until they have finished shading with Indian ink, but it is much better to colour the water before it is shaded, as the ink frequently runs when a wash is laid upon it.

2. Here it may not be improper to observe that in colouring lakes, rivers, &c. with Prussian blue, the wash should be pretty strong at the edges, and softened off with water towards the middle.

*Hilly Ground.*

Meadow and pasture ground should first be washed with a fine green, and ploughed land with a yellowish brown, as before directed ; the hills must then be shaded in lines, with a pen and Indian ink, as represented in Nos. 5 and 6, Plate VII.

The sides of hills may be shaded in the manner represented in the lower part of No. 6 ; and when the top of a hill is level, it must be left almost without shade.

The greater the altitude of a hill, the deeper must be the shade ; but the level part of a valley between two hills must be very faintly shaded.

It will add greatly to the beauty of the plan or map if all the hills be introduced in their proper places. When this is the case, and the hills are properly shaded, they form what is called a *bird's eye view* ; it being supposed that the eye of the observer is elevated to some distance from the ground.

What has been said on this subject will be fully comprehended by the learner, if he carefully examine the plate to which I have already referred, and also No. 5, Plate VI., which represents a high moorish district shaded in a very neat and expressive manner.

*Pleasure-Grounds.*

In order to draw a true plan of pleasure-grounds, it is necessary to measure such lines, in taking the survey, as will enable you to lay

down correctly the shrubberies, grass-plots and fish-ponds, the bases of summer-houses and alcoves, and the turnings and windings of all the gravel-walks, &c.

The trees, bushes, bases of buildings, &c., must then be neatly made; the fish-ponds and grass-plots properly coloured and shaded, as before directed, for lakes and meadows: and the gravel-walks washed with a fine brown inclining to yellow.

NOTE 1. If the mansion-house, stables, gardens, &c., be situated within the pleasure-grounds, the greatest care should be taken to lay them down correctly, so that the smallest inaccuracy in the plan shall not be perceptible.

2. When pleasure-grounds are surveyed and planned with adjoining estates, the same scale must, of course, be used for the whole; but when the former are measured separately, a large scale should be chosen, in order to allow sufficient room to plan every object distinctly.

#### *Gardens.*

Gardens should be correctly and neatly planned, and finished in a tasteful and elegant manner.

The hot-houses, green-houses, grass-plots, gravel-walks, beds, &c., should all be drawn and laid out as they appear in the garden itself.

The divisions between the different beds may be made with short dashes, as represented in Nos. 3 and 4, Plate VI.; the beds should then be lightly shaded with a pen and Indian ink; rows of bushes inserted along the sides of the walks, and at the divisions of the various beds; and trees should be shown as before directed, if there be any in the garden.

The gravel-walks must then be washed with a yellowish brown; the grass-plots with green; and the different beds with a light tint of yellow, red, lake, blue, green, or any other colours, so as to produce a pleasing variety: and the trees may be touched up with a little dark green, and occasionally a brownish or yellowish tint may be used, to give them an autumnal appearance.

NOTE. When plans are to be finished with colours, it is not necessary to shade them so much with Indian ink as when they are finished with Indian ink only.

#### *The Bases of Buildings.*

The outlines of the bases of buildings must be made with a drawing-pen and Indian ink, bold and black on the south and east sides, or on the north and west sides; and the spaces in the middle filled up with oblique lines, as represented in No. 7, Plate VII., which is given expressly for the purpose of making the learner fully acquainted with the method of shading the bases of buildings, drawing the plans of villages, towns, &c.

NOTE 1. When a proprietor wishes to have a plan of his buildings, offices, yards, &c., upon a large scale, the dimensions should be taken in feet and inches, or in feet and tenths, which is preferable ; because the chains and tenths of a chain, upon the plotting-scale, may then be considered as feet and tenths, and used accordingly in planning ; or when it is more convenient, each chain may be called ten feet ; consequently, each division will then become one foot. (See Note 3, Prob. I. Part III.)

2. When it is intended to lay down buildings by a large scale, the thickness of the walls, the lengths and breadths of rooms and passages, the widths of doors and windows, the projections of fireplaces, and other necessary dimensions, should be taken, in order to produce a correct plan.

3. After the base of a wall has been formed by parallel lines, drawn at such a distance from each other as to exhibit the wall's thickness, the space between these lines may then be shaded by oblique lines as before directed. The doorways should be left open ; the window-bottoms represented, by omitting to shade them with oblique lines ; the chimney-bottoms or fireplaces exhibited by making the inside of the wall to project into the room at right angles ; and the steps of the stairs denoted by parallel lines, drawn at proper distances from each other. The insides of the rooms may either be left white or coloured at the option of the draughtsman ; and if it be thought tedious to shade the bases of the walls with oblique lines, they may be done with a brush and Indian ink.

4. The name of every room, office, yard, &c., must be given, either within the rooms themselves, or in the margin of the plan ; and when the premises are extensive, the names of the rooms, out-offices, yards, &c., will be numerous ; there will probably be the kitchen, back-kitchen, parlour, hall, breakfast-room, dining-room, drawing-room, dairy, pantry, stairs, brew-house, wash-house, coal-house, carriage-house, stables, cow-house, calf-house, hog-sty, soil-hole, barn, stable-yard, court-yard, orchard, garden, &c. What has been said on this subject will be easily comprehended by inspecting No. 2, Plate V., which is the ground-plan of a small house, laid down by a large scale, in order to show the learner how he must proceed with plans of a similar nature.

5. When premises are to be sold, every convenience should be pointed out on the plan, in order to promote the sale, and it will be found very advantageous to have plans of the cellars and the upper stories, and even the elevations ; but this is more properly the business of an architect than that of a land-surveyor. Some persons, however, will find it of considerable advantage to obtain a knowledge of both these sciences, as gentlemen frequently want not only plans of their estates, but also architectural drawings of their buildings.

### *The Elevations of Buildings.*

In order to give a *perspective* view of the elevation of a building, it is necessary to be acquainted with the art of drawing in perspective ; but an *architectural* view may be produced by taking the dimensions of the building, and laying them down by a scale of equal parts.

When it is intended to give the elevation of any buildings belonging to a farm, or the elevation of a mansion-house and offices belonging to a gentleman's estate, the length from end to end, the perpendicular height from the ground to the eaves, the height of the

gable ends, the height and breadth of the chimney-tops, the height and width of the doors and windows, their situations in the walls, and every other necessary dimension, must be measured; then these dimensions, being correctly laid down by a scale, will give an architectural view of the elevation of the building in question.

What has been advanced on this subject will be farther illustrated by referring to No. 8, Plate VII., which is an architectural view of a gentleman's house, given for the inspection and improvement of the learner. The house itself is built with gable ends, but the roofs of both the wings are hipped at one end, which make a pleasing contrast in the elevation.

**NOTE 1.** After the outlines of an elevation are drawn, the common method of shading is by a brush and Indian ink, as it is generally thought too tedious to shade with strokes in imitation of engraving. The roof should be shaded pretty strongly at the ridge, and softened off towards the middle with water. It may then be washed with Prussian blue; and if the washes, both of Indian ink and colour, be light and often repeated, a more agreeable softness will be produced than by laying on only two or three strong washes. When the roof has been thus shaded, lines may be drawn parallel to the eaves, decreasing gradually in their distance from each other towards the ridge, to represent the edges of the slates. If the house be covered with tiles, the lines must be at equal distances from each other; because tiles of different sizes are never laid upon the same house.

2. If the front of a building project beyond the wings, it must be denoted by making its shadow fall upon one of the wings; but if the wings project beyond the front, the shade of one of them must be made to fall upon the front. (See No. 8, Plate VII., where the shade of the front falls upon the right wing; if the wings had projected, the shade of the left wing would have fallen upon the front.)

3. If a house be built of brick, it may be coloured red; if of stone, a colour may be chosen to resemble it; and when a roof is covered with grey slates, blue slates, or red tiles, it may be coloured accordingly. Sometimes the front of a building is shaded with Indian ink, the roof tinted with blue, and the stone door-posts, window-jambes, string-courses, chimney-tops, &c., coloured so as to resemble stone. Indian ink, however, is generally used for fronts in preference to any colour, as it is considered to give buildings a much richer appearance.

4. If there be trees about the buildings, they may be *etched* with a pen and Indian ink in imitation of engraving; the ground in front should be properly shaded; the gravel-walks coloured with a light brown; and if the elevation be bordered with black lines, as in No. 8, Plate VII., the sky may be coloured with a fine blue, or shaded with Indian ink.

5. The elevations of buildings belonging to estates that have been surveyed should be given on vacant parts of the plan, as embellishments: it is very seldom indeed that they are drawn in their true situations, because they would intercept the view of the ground-plot; and besides, they are generally laid down by a much larger scale. The mansion-house of a nobleman, well executed, on a vacant part of the plan of his estate, has a very pleasing effect, and will never fail to gratify the proprietor.

6. It is almost superfluous to remind the young draughtsman that he should always keep his hands perfectly clean, and off his plans, so as to preserve them

from being in the least soiled in drawing them, as nothing exhibits the carelessness of a draughtsman in a more conspicuous light than seeing his work besmeared with dust, ink, or colours.

### METHOD III.

#### *Plans highly finished with Indian Ink.*

A plan highly finished with Indian ink only, has a very elegant appearance, and is considered by most persons to excel those done in colours; but the process is very tedious, and requires much time to do it neatly; however, ~~if the surveyor be well~~ paid for his time, he ought to finish his plans in that manner which is most likely to give satisfaction to his employers.

Many surveyors keep plans by them, finished in various ways, as specimens, in order that gentlemen may have an opportunity of choosing in what manner they will have the plans of their estates executed.

#### *Shading with the Pen.*

In finishing a plan with Indian ink, a fine pen ought to be used; and the fields should be shaded in a great variety of forms, in imitation of engraving, as exhibited in Plates VI., IX., and XI.

Some fields should be done lighter, and others darker, so as to produce a pleasing contrast of light and shade. Some may be executed in such a manner as to resemble corn-fields, as in Nos. 1 and 6, Plate IX., and 13 and 16, Plate XI., and others may be shaded like meadow and pasture, as exhibited in Nos. 1 and 2, Plate VI.

High moorish ground should be shaded as represented in No. 5, Plate VI.; and marshy grounds, sands, loose stones, rocks, trees, water, hilly fields, and the bases of buildings, as denoted in Plate VII.; and even the elevations of buildings look very elegant when they are finely shaded with lines, as No. 8 in the Plate to which we last referred.

**NOTE.** In finishing a plan with Indian ink only, it is necessary to shade it much closer and deeper than in finishing with Indian ink and colours.

#### *Penmanship.*

In making finished plans, no ornaments or embellishments will compensate for bad penmanship.

Writing, German-text, printing, and figures, are all essentially necessary for a draughtsman; and whoever would excel in the art of planning should use his utmost endeavours to become a complete and elegant penman.

He should practise the various hands, either by copies well written or by good copper-plates, until he can make all the letters and figures

correctly and with true taste ; and it will save him much trouble in making compartments and devices if he can acquire the art of flourishing and ornamenting neatly and elegantly with the pen.

*Ornaments.*

Any compartment or device may be chosen to fill up the vacant corners of a plan, such as the compass, scrolls of paper, wreaths or festoons of leaves and flowers, branches or sprigs of oak, palm-tree, weeping-willow, myrtle, laurel, olive, &c. ; also shields, coats of arms, columns supporting vases or urns, mathematical instruments, cattle, sheep, or whatever else may please the fancy of the draughtsman.

*Ornaments on Plate IX.*

In the NW. corner is a device formed of an oak branch, leaves and acorns on the left side ; and on the right side is a branch of large pointed leaves resembling sedges or sweet flags, intertwined with a string of small leaves ; and both branches are united at the bottom by a bunch of riband.

In the SW. corner is a scroll of paper, supported by a fluted column ; by the side of which are some ears of corn, and at the bottom a few blades of grass and herbage.

In the NE. corner is the sun in his meridian splendour, with a fancy device resembling an ogee cornice, fronted with reeds, and from each end of the cornice is suspended a festoon of small leaves.

In the SE. corner is a plotting-scale, a pair of compasses, two drawing-pens, and a writing-pen, interwoven with a garland of small leaves and berries, resembling those of the myrtle.

*Ornaments on Plate XI.*

In the NW. corner is a fancy device in the form of an oval, and in the NE. corner is a rectangular device, with the exception of the arch at the top. This device is ornamented with a bunch of riband, and two festoons of small leaves and berries, hanging upon two scutcheons, or shields.

In the SW. corner is a column, at the top of which is a vase encircled with leaves and flowers. On the west of the column Britannia is seated, leaning on her shield, holding a spear in her right hand, and with her left hand pointing out the science of Surveying. To the east of the column are two sheep, emblems of agriculture.

The plotting-scale, drawing-pens, &c., are nearly similar to those in the last plate.

In the S.E. corner is a parallel ruler, a plane table, a terrestrial globe, a crowing cock, and a youth seated upon a bee-hive, with a pair of compasses in his hand, at work upon Plate XII.

The cock is an emblem of early rising, and the bee-hive may be considered as an emblem of industry ; and it may here be remarked that it is impossible to attain eminence in the art of surveying without early rising, industry, and perseverance.

---

### MISCELLANEOUS INSTRUCTIONS

#### *Relating to Surveying, Planning, Casting, Valuing, &c.*

1. The title of a plan should set forth the name of the proprietor, and also the name of the township, hamlet, parish, and county in which the estate is situated.
2. The names of the adjoining lordships, or the names of the proprietors of the adjoining lands, should be given on the plan, in order to point out clearly the situation of the estate and corroborate the title.
3. All principal roads passing through the estate, from one highway to another, should be laid down, and the places to which they lead specified.
4. All foot-paths and bridle-roads should be pointed out, in order to determine the public right, and guard against encroachments.
5. All occupation and privileged roads, through adjoining estates, should be noticed either on the plan or in the reference book.
6. All ancient highways leading through the estate, although not now in use, should be particularly specified, and the names of the proprietors given, to show in whom the privilege of reopening them, if necessary, is vested.
7. The ancient and proper names of fields should be preserved, as it generally creates confusion and mistakes when new ones are assigned without sufficient authority.
8. It has already been observed, that the extremities of the ditches are generally the boundaries between adjoining fields ; this, however, is not always the case, as the stem of the quickwood sometimes forms the boundary ; hence the necessity of obtaining an assistant who is well acquainted with all the local customs of the place.
9. The greatest care must be taken to find the area of each field correctly ; and particularly if the survey be taken for an inclosure, or to make a valuation for the land-tax, poor-rates, county-rates, and other assessments ; for it is evident that if the survey be incorrect,



the valuation can never be equitable, and will consequently produce nothing but disputes and dissatisfaction among the proprietors and occupiers, instead of peace, harmony, and friendship.

10. In valuing for an assessment, great care should be taken not to over-rate the land that is of a poor quality and lies far from the means of improvement ; for bad land costs the occupier as much in labour and seed as good land, and is far less productive. (See more observations on valuing land in Part VI.)

11. In reducing a plan for portable use, care should be taken to choose a scale sufficiently large to exhibit all the irregularities in the fences, buildings, &c.

12. Several small farms, or detached pieces of land, belonging to one proprietor, may be laid down upon the same sheet. They ought not, however, to be joined together, but planned as separate estates.

13. When one sheet of drawing-paper is too small to contain the survey, two or more must be neatly pasted together ; and when those parts that have been wet with the paste are nearly dry, they may be made smooth by a warm *iron*. The edge of one of the sheets should be cut even, and laid nearly half-an-inch over the edge of the other sheet ; and a piece of clean paper should be laid under the *iron*, to prevent it from soiling the plan.

14. It has already been observed that the surveying-chain should frequently be measured. The readiest method of doing this is to drive two stakes or pins into the ground, exactly at the distance of 22 yards from each other. Professional surveyors measure their chains in this manner every morning, when they are engaged in extensive measurements. When the chain has become too long, it is better to cut a little from several of the links than to take off the rings ; care, however, must be taken to keep each 10 links of an equal length, or the dimensions will be incorrect.

15. The book of particulars before mentioned is generally called 'A Terrier of the Survey,' and should contain references corresponding to those upon the plan ; also the name of each field, or the name of the proprietor, or of the occupier, and the area of each field in acres, roods, and perches. If the surveyor value the estate, the terrier ought to contain the value per acre to let or for sale ; the annual value of each field to let, or the total value for sale ; and also the cultivation of each field : thus will the proprietor be furnished with every necessary particular relating to his estate.

16. The terrier may likewise contain remarks and observations on the quality of the soil ; and point out the method of improving wet marshy grounds, by draining them ; commons and waste lands by inclosing them ; large fields, by dividing them ; &c.

17. Some surveyors return three measurements of each field in the terrier; viz., the land in cultivation, the hedges and waste land, and the total quantity or sum of both.

18. Arable lands should be distinguished from permanent meadows, and those which the tenant is prohibited from breaking up should be particularly noticed.

19. In writing out a valuation book for the purpose of making assessments, all the lands and tenements in the occupation of the same tenant should be collected together, and put down on the left-hand page of the book. At the top of the page must appear the name of the tenant; and in the first and second columns respectively, the names of the proprietors and the numbers on the plan. The third, fourth, fifth, and sixth columns must contain the name, measurement, value per acre, and total value of each field respectively. The right-hand page may be left blank for incidental remarks, when a change of occupation takes place, or when any circumstance occurs that affects the arrangement of the book.

20. When the valuation is high, it is frequently thought prudent to calculate the assessments from one-fourth, one-half, or three-fourths of the amount; this, however, is more properly the consideration of the occupiers than that of the Land-Surveyor. Sometimes the assessments are calculated from one-half or three-fourths of the valuation of the land, and from one-fourth of the valuation of the buildings.

*A terrier of the survey in Plate IX.*

Nos. on the plan.	Names of the Fields.	Cultivation of the Ground.	Area in A. R. P.	Value per Acre to rent.			Total Value per Annum to rent.		
				£	s.	d.	£	s.	d.
1	Calf Garth .	Pasture .	1 0 20	2	12	6	2	19	0½
2	Lane Close .	Arable .	2 2 38	1	16	0	4	18	6½
3	Low Close .	Permanent Meadow }	2 0 10	2	2	6	4	7	7½
4	Turnpike Close	Arable .	13 1 28	1	14	0	22	16	5½
5	Daisy Field .	Meadow .	11 0 9	1	15	6	19	12	5½
6	Triangle .	Pasture .	12 2 18	2	3	6	27	8	7½
Sum total .			43 0 3	.....			82	2	9½

NOTE 1. The annual value of each field may be found from the area, and the value per acre by the Rule of Three.

2. If one tenant occupy all the foregoing estate, his rent will be 82*l.* 2*s.* 9*d.* per annum; and if the assessments be made from three-fourths of the annual value, he will be assessed at 62*l.* 12*s.* 1*d.*

3. The terrier may be divided into any number of columns, to suit the purpose of the surveyor; and when the observations, remarks, &c., are too numerous to be contained in the columns of one page, each two opposite pages may be divided into columns, in which may be entered every necessary information relating to the estate

4. In extensive surveys and valuations, an alphabetical index should be annexed to the terrier or valuation-book, in order that the name of any particular proprietor or occupier may be more readily found.

## PART VI.

**RULES AND DIRECTIONS FOR APPORTIONING LAND; FOR LAYING OUT ANY GIVEN QUANTITY OF LAND, IN ANY PROPOSED FIGURE; FOR PARTING FROM ANY FIELD OR FIGURE ANY QUANTITY OF LAND REQUIRED; AND FOR DIVIDING A PIECE OF LAND AMONG SUNDRY CLAIMANTS IN THE PROPORTION OF THEIR RESPECTIVE CLAIMS, OR A COMMON, ETC., OF VARIABLE VALUE AMONG ANY NUMBER OF PROPRIETORS, IN THE PROPORTION OF THEIR RESPECTIVE INTERESTS.—LANDS INTERSECTED BY A RAILWAY.—VERTICAL SURVEY OF EMBANKMENTS, RIVERS, CANALS, AND LANDS RECLAIMED FROM THE SEA.—ALSO, THE METHOD OF REDUCING STATUTE MEASURE TO CUSTOMARY, AND *VICE VERSA*.**

### SECTION I.

*Rules and directions for laying out any given quantity of land in any proposed figure, and for parting from any field or figure any quantity of land required.*

When the land to be laid out or parted off is given in acres, roods, and perches, it must first be reduced into square links; in which process the following table will be found extremely useful.

When it is required to part off from any field or figure any quantity of land, it is generally necessary, first, to measure the whole, if the dimensions be not given.

*A table for reducing acres, roods, and perches, into square links.*

Acres.	Sq. Links.	Perches.	Sq. Links.	Perches.	Sq. Links.
1	100000	1	625	21	13125
2	200000	2	1250	22	13750
3	300000	3	1875	23	14375
4	400000	4	2500	24	15000
5	500000	5	3125	25	15625
6	600000	6	3750	26	16250
7	700000	7	4375	27	16875
8	800000	8	5000	28	17500
9	900000	9	5625	29	18125
10	1000000	10	6250	30	18750
20	2000000	11	6875	31	19375
30	3000000	12	7500	32	20000
40	4000000	13	8125	33	20625
50	5000000	14	8750	34	21250
60	6000000	15	9375	35	21875
70	7000000	16	10000	36	22500
80	8000000	17	10625	37	23125
90	9000000	18	11250	38	23750
100	10000000	19	11875	39	24375
<b>Roods</b>	<b>Sq. Links</b>	20	12500		
1	25000				
2	50000				
3	75000				

### PROBLEM I.

*To reduce any number of acres, roods, and perches into square links.*

**RULE.**—Reduce the given quantity of land into perches, which multiply by 625, the number of square links in one perch, and the product will be the square links required. Or, find the equivalents of the acres, roods, and perches respectively in the foregoing table.

#### *Examples.*

1. Reduce 6A. 3R. 25P. into square links.

By the rule.

$$\begin{array}{r}
 \text{A. R. P.} \\
 6 \ 3 \ 25 \\
 4 \\
 \hline
 27 \\
 40 \\
 \hline
 1105 \\
 625 \\
 \hline
 5525 \\
 2210 \\
 6630 \\
 \hline
 690625 \text{ Ans.}
 \end{array}$$

By the table.

$$\begin{array}{r}
 \text{sq. links} \\
 6\text{A.} = 600000 \\
 3\text{R.} = 75000 \\
 25\text{P.} = 15625 \\
 \hline
 690625 \text{ Ans.}
 \end{array}$$

2. Required the number of square links in 96A. 2R. 36P.

*Ans.* 9672500.

### PROBLEM II.

*To lay out, in a square, any quantity of land proposed.*

**RULE.**—Extract the square root of the proposed area, and it will be the side of the square required.

*Examples.*

1. Lay out in a square 7 acres, 1 rood, and 24 perches.

$$\begin{array}{r}
 \text{sq. links.} \\
 7\text{A.} = 700000 \\
 1\text{R.} = 25000 \\
 24\text{P.} = 15000
 \end{array}$$

$\sqrt{740000}$ (860.2 links, the side of the square.

$$\begin{array}{r}
 64 \\
 166 \overline{)1000} \\
 \underline{996} \\
 17202 \overline{)40000} \\
 \underline{34404} \\
 \underline{\underline{.5596}}
 \end{array}$$

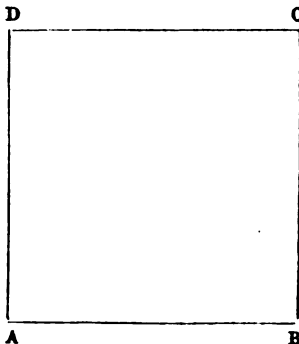

In laying out the square in the field, let  $AB$  represent one of its sides, which make = 860·2 links. At  $A$  erect the perpendicular  $AD$ , which make =  $AB$ ; and at  $B$  erect the perpendicular  $BC$ , which make also =  $AB$ . Then measure the line  $CD$ , and if you find it = 860·2 links, the work is right.

2. Required the side of a square which shall contain 15A. 2R. 32P.  
*Ans.* 1253 links.

### PROBLEM III.

*Upon a given line, to make a rectangle that shall contain any proposed quantity of land.*

**RULE.**—Divide the proposed area by the given side, and the quotient will be the other side of the rectangle.

*Examples.*

1. Lay out 3A. 3R. 26P. in the form of a rectangle, one side of which must be 850 links.

$$\begin{array}{r}
 \text{sq. links} \\
 3\text{A.} = 300000 \\
 3\text{R.} = 75000 \\
 26\text{P.} = 16250 \\
 85,0 \overline{)39125,0} (460\cdot3 \text{ links, the other side.} \\
 \underline{340} \\
 \quad \cdot 512 \\
 \quad \underline{510} \\
 \quad \quad \cdot \cdot 250 \\
 \quad \quad \underline{255} \\
 \quad \quad \quad \underline{\quad}
 \end{array}$$

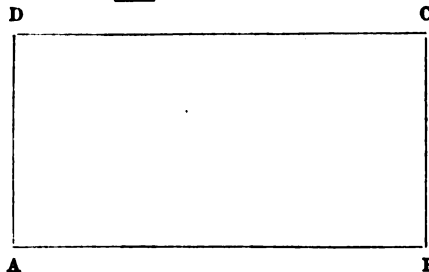

In laying out the rectangle in the field, let  $AB$  represent the given side. At  $A$ , erect the perpendicular  $AD$ , which make = 460·3 links; and at  $B$ , erect the perpendicular  $BC$ , which make =  $AD$ . Then measure the line  $CD$ , and if you find it =  $AB$ , the work is right.

2. If one side of a rectangle be 525 links, required the other side, so that the figure may contain 6A. 2R. 23P. *Ans.* 1265·5 links.

## PROBLEM IV.

To lay out any given quantity of land in a rectangle, so that one of its sides shall be two, three, four, or any number of times as long as the other.

RULE.—Divide the given area by the given number, and the square root of the quotient will be the shorter side, which multiply by the given number, and the product will be the longer side.

*Examples.*

1. Lay out 3A. 0R. 32P. in the form of a rectangle, one of the sides of which shall be twice as long as the other.

$$\begin{array}{r}
 \text{sq. links.} \\
 3\text{A.} = 300000 \\
 32\text{P.} = 20000 \\
 \hline
 2)320000 \\
 \underline{160000} \text{ (400 links the shorter side} \\
 16 \quad \quad 2 \\
 \underline{.0000} \quad \underline{800 \text{ links, the longer ditto.}}
 \end{array}$$

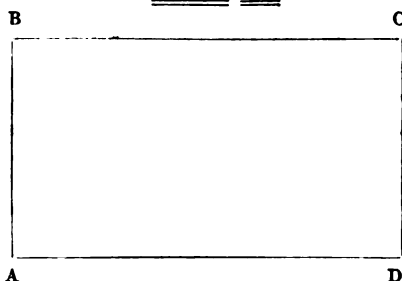

Let ABCD represent the rectangle, which you must lay out according to the directions in the last problem; AD being 800, and AB 400 links.

2. A rectangle contains 7A. 2R. 0P.; what are its sides, one of them being three times the length of the other?

*Ans. 1500 and 500 links.*

## PROBLEM V.

Upon a given base to lay out a triangle that shall contain any given number of acres, &c.

RULE.—Divide the area by half the base, or twice the area by the whole base, and the quotient will be the perpendicular of the triangle.

*Examples.*

1. Lay out 3A. 2R. 16P. in the form of a triangle, the base of which must be 1200 links.

$$\begin{array}{r}
 \text{sq. links.} \\
 3A. = 300000 \\
 2R. = 50000 \\
 16P. = 10000 \\
 \hline
 6,00 \overline{)3600,00} \\
 \hline
 \underline{\underline{600}} \text{ links, the perpendicular.}
 \end{array}$$

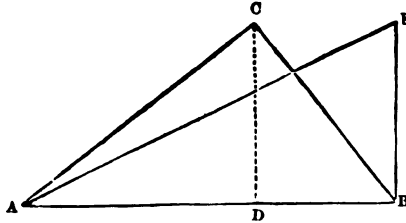

Upon any part of the given base AB, suppose at D, erect the perpendicular DC, which make = 600 links; then stake out the lines AC and BC; so will ABC be the required triangle. But if the perpendicular be erected at either end of the base, as at B, then the line AE must be staked out; and ABE will be the triangle required.

2. Required the perpendicular of a triangle, which contains 6A. 2R. 37P., its base being 1556 links. *Ans. 865.2 links.*

#### PROBLEM VI.

*To lay out a trapezium that shall contain any number of acres, &c., having one of its sides or a base line given.*

**RULE 1.**—Divide the given area into two parts, either equal or unequal; and then, by the last problem, find the perpendicular that will lay out one of these parts in a right-angled triangle upon the given base.

You must then consider this perpendicular as one of the diagonals of the trapezium, and also the base upon which you must lay out the other triangle.

**RULE 2.**—Divide the given area into any two parts as before; and then find the perpendicular that will lay out one of these parts in a right-angled triangle upon the given base.

Add the square of the perpendicular thus found to the square of the given base, and the square root of the sum will be the hypotenuse. Consider this hypotenuse as one of the diagonals of the trapezium, and also the base upon which the other triangle must be laid out.

#### *Examples.*

1. Lay out 8 acres in a trapezium, upon a given side of 800 links.



BY THE FIRST RULE.

Divide the given area into 5 and 3 acres, and let the triangle upon the given side contain the greater part.

$$5A. = 500000 \text{ square links}$$

$$\begin{array}{r} 8,00 \overline{)10000,00} \end{array}$$

1250 links, the perpendicular of the first triangle, and also the base of the second

$$3A. = 300000 \text{ square links}$$

$$\begin{array}{r} 125,0 \overline{)60000,0} \text{(480 links, the perpendicular of the second triangle} \\ \underline{500} \\ 1000 \\ \underline{1000} \\ \dots 0 \end{array}$$

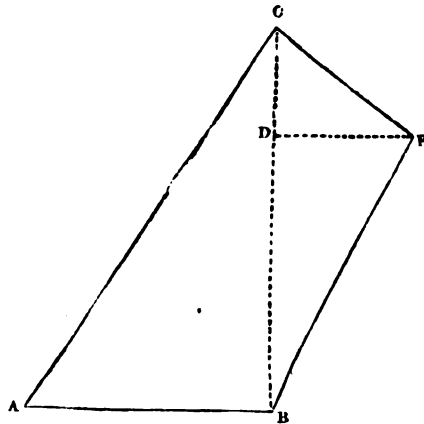

In laying out the trapezium in the field, let AB represent the given side. At B, erect the perpendicular BC, which make = 1250 links. Then, upon any part of the line BC, as at D, erect the perpendicular DE, which make = 480 links. The four outlines being properly staked out, the work will be completed.

BY THE SECOND RULE.

$$5A. = 500000 \text{ square links}$$

$$\begin{array}{r} 8,00 \overline{)10000,00} \end{array}$$

1250 links, the perpendicular of the first triangle.

Then,  $\sqrt{1250^2 + 800^2} = \sqrt{1562500 + 640000} = \sqrt{2202500} = 1484$  links, the hypotenuse of the first, and also the base of the second triangle.

3A. = 300000 square links.

$$\begin{array}{r}
 2 \\
 \hline
 1484)600000(404\cdot3 \text{ links, the perpendicular of the second} \\
 \underline{5936} \qquad \qquad \qquad \text{triangle} \\
 \cdot 6400 \\
 \underline{5936} \\
 \cdot 4640 \\
 \underline{4452} \\
 \cdot 188 \\
 \hline
 \hline
 \end{array}$$

Having laid out the triangle ABC as before directed, upon any part of the line AC, as at D, erect the perpendicular DE, which make = 404·3 links. Stake all the outlines, and the work will be completed.

2. Lay out 12A. in a trapezium, upon a given side of 1400 links.

*Ans.* Supposing the given area divided into 7 and 5 acres: then, by the first Rule, the perpendicular of the first triangle is found to be 1000 links, and that of the second the same.

By the second Rule, the perpendicular of the first triangle is found to be 1000 links, the base of the second 1720·5, and its perpendicular 581·2 links.

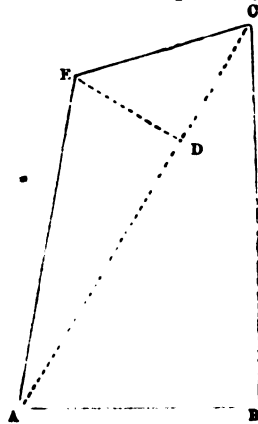

### PROBLEM VII.

*Upon a given base, to lay out a rhombus of any content less than the square of the base.*

**RULE.**—Divide the content by the base, and the quotient will be the perpendicular. Then from the square of the base subtract the square of the perpendicular, and find the square root of the remainder. Upon the base, from one of its extremities, measure a line equal to this root, and at this point erect a perpendicular.

#### *Examples.*

1. Lay out in a rhombus 5A. 2R. its base being 800 links.

$$\begin{array}{r}
 \text{sq. links.} \\
 5\text{A.} = 500000 \\
 2\text{R.} = 50000 \\
 16\text{P.} = 10000 \\
 \hline
 8,00)5600,00 \\
 \hline
 700 \text{ links, the perpendicular.}
 \end{array}$$

Then,  $\sqrt{800^2 - 700^2} = \sqrt{640000 - 490000} = \sqrt{150000} = 387.3$  links, at which distance from one of the extremities of the base the perpendicular must be erected.

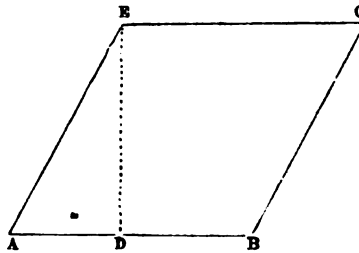

In laying out the rhombus in the field, let AB represent the given base. From A, on the line AB, measure 387.3 links to D; and at D erect the perpendicular DE, which make = 700 links. At E, erect the perpendicular EC, which make = the base AB. Measure the lines CB and AE, and if you find each of them = AB, the work is right.

2. Lay out a rhombus, which shall contain 6A. 1R. 8P. upon a base measuring 900 links.

*Ans.* The perpendicular is found to be 700 links, and the distance at which it must be erected from one of the extremities of the base 565.7 links.

### PROBLEM VIII.

*To lay out any given quantity of land in a circle.*

**RULE 1.**—If we multiply the square of the diameter of any circle by .7854, the product will be the area; consequently, if we divide the area by .7854, the quotient will be the square of the diameter.

2. Multiply the square root of the area by 1.12837, and the product will be the diameter.

#### *Examples.*

1. Lay out one acre of land in a circle.

sq. links	
7854	diameter
21460	
15708	
<u>.57520</u>	
54978	
<u>.25420</u>	
23562	
<u>.18580</u>	
15708	
<u>.28720</u>	
23562	
<u>.51580</u>	
47124	
<u>.44560</u>	
39270	
<u>.5290</u>	

Then,  $\sqrt{127323.65} = 356.82$  links, the diameter of a circle containing one acre of land.

Or, by the second rule,  $\sqrt{100000} = 316.227$ ; and  $316.227 \times 1.12837 = 356.82$  links, the diameter, as before.

In laying out the circle in the field, provide a strong cord, in length equal to the radius of the circle, which in this case will be 178.4 links; and fixing one of its ends at B, as a centre, make the other fast to your offset-staff near its lower extremity. Then stretch the cord to A, and with the line AB describe the circle, keeping the staff perpendicular, and making a mark on the ground with its spike, by which you must stake out the circumference.

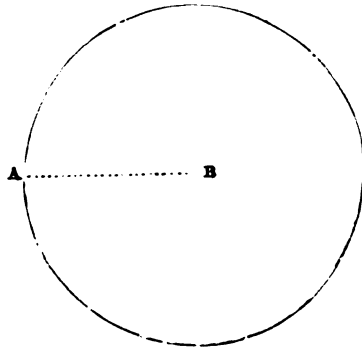

Or at proper intervals stretch the radius AB, and put down stakes in such a manner as to form the circumference.

2. Required the diameter of a circle, which will contain half an acre of land.

*Ans. 252.3 links.*

## PROBLEM IX.

To lay out any given quantity of land in a regular polygon.

**RULE.**—Divide the area of the required polygon by the area standing opposite to its name in the subjoined table, and the square root of the quotient will be the length of the side. Multiply the side thus found by the polygon's number, in the column of radii, and the product will be the radius of the circle circumscribing the required polygon.

*A table of regular polygons, with their areas, and the radii of their circumscribing circles, when the side of the polygon is 1.*

No. Sides.	Names.	Areas.	Radii.
3	Triangle . . .	0·433	0·577
4	Square . . .	1·	0·707
5	Pentagon . . .	1·72	0·851
6	Hexagon . . .	2·598	1·
7	Heptagon . . .	3·634	1·152
8	Octagon . . .	4·828	1·306
9	Nonagon . . .	6·182	1·462
10	Decagon . . .	7·694	1·619
11	Undecagon . . .	9·365	1·775
12	Duodecagon . . .	11·196	1·932

**NOTE.**—If the square of the side of any polygon be multiplied by the area standing opposite to its name in the preceding table, the product will be the area of the polygon.

*Examples.*

1. Lay out one acre of land in a regular hexagon.

Here  $\frac{100000}{2\cdot598} = 38491\cdot147$ ; and  $\sqrt{38491\cdot147} = 196\cdot191$  links,

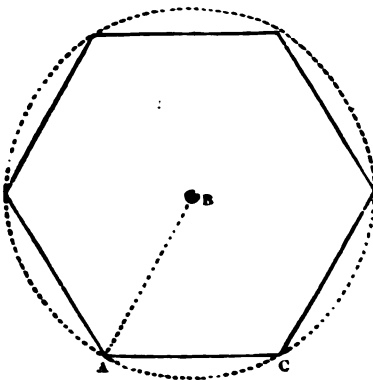

the side of the required polygon, and also the radius of the circumscribing circle, because the side of a regular hexagon and the radius of its circumscribing circle are always equal to each other; hence the multiplier in the table is 1.

To lay out the hexagon in the field, draw the circumscribing circle as directed in the last problem. Then the radius AB, which is equal to the side of the

hexagon, being applied six times, will just go round the circumference, and form the polygon required.

2. Lay out half an acre of land in a regular octagon.

*Ans.* The side of the required octagon is 101·76, and the radius of its circumscribing circle 132·898 links.

### PROBLEM X.

*To lay out any given quantity of land, in an ellipsis, having one of the diameters given.*

**RULE.**—If we multiply the rectangle of the two diameters of an ellipsis by ·7854, the product will be the area ; consequently, if we divide the area by ·7854, and that quotient by the given diameter, the latter quotient will be the diameter required.

#### *Examples.*

1. Lay out an ellipsis, which shall contain one acre, with a transverse diameter of 450 links.

$$\begin{array}{r}
 \text{sq. links.} \\
 \cdot 7854 \overline{) 100000 \cdot 00000} (127323 \cdot 6 \text{ quotient.} \\
 \underline{7854} \\
 21460 \\
 \underline{15708} \\
 .57520 \\
 \underline{54978} \\
 .25420 \\
 \underline{23562} \\
 .18580 \\
 \underline{15708} \\
 .28720 \\
 \underline{23562} \\
 .51580 \\
 \underline{47124} \\
 \underline{\underline{.4456}}
 \end{array}$$

Then,  $\frac{127323 \cdot 6}{450} = 283$  links, the conjugate diameter.

By Prob. XV., Part I., construct the ellipse ABCD ; then by a property of the ellipse, the square of the distance of the focus from

the centre is equal to the difference of the squares of the semi-diameters: hence, we have  $\sqrt{225^2 - 141.5^2} = \sqrt{30602.75} = 175$  links, equal  $fo$ , or  $fo$ : and  $225 - 175 = 50$  links, equal  $AF$ , or  $Bf$ .

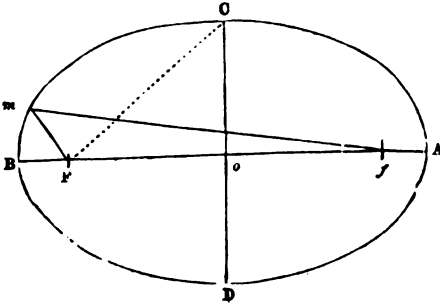

Again, by another property of the ellipse, the sum of the two lines drawn from the two foci, and meeting in any point in the circumference, is equal to the transverse diameter; that is,  $Fm + fm = AB$ .

Procure, therefore, a cord, and upon it make two loops, so that the distance between them may be equal to the transverse diameter; then measure in the field the diameter AB, putting down a stake at each focus, and one at the centre o. At o erect the perpendiculars oC and oD, making each = 141.5 links.

Put the two loops over the stakes at F, f, and stretch the cord so that the two parts  $Fm$ ,  $fm$ , may be equally tight; at m put down a stake as one point in the circumference of the ellipse, and in the same manner determine as many others as you please.

But if the ellipse be very large, so that you cannot conveniently procure a cord as long as the transverse diameter, you must then erect perpendiculars, called ordinates, at every 50 links, or at every chain's length, &c., upon that diameter, and measure the lengths of these perpendiculars by the scale.

Then measure in the field the transverse and conjugate diameters, and erect the perpendiculars in their proper places, always remembering to put down a stake at the end of each perpendicular.

2. Lay out an ellipse which shall contain 8A. 3R. 8P., one of the diameters being given equal to 800 links.

*Ans.* The other diameter is = 1400 links.

**PROBLEM XI.**

*To part from a square or rectangle any proposed quantity of land by a line parallel to one of its sides.*

**RULE.**—Divide the proposed area by the side upon which it is to be parted off, and the quotient will be the length of the other side of the figure required.

*Examples.*

1. From the square ABCD, containing 6A. 1R. 26P., part off 3A. by a line parallel to AB.

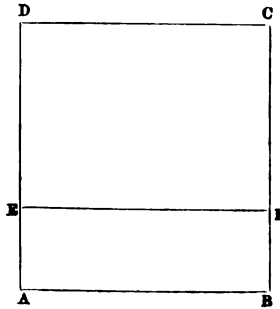

sq. links  
 6A. = 600000  
 1R. = 25000  
 24P. = 15000  

---

 640000 (800 links, the side of the square  
 64  

---

 .. 0000

Then,  $\frac{300000}{800} = 375$  links, the side AE or BF required.

2. From the rectangle ABCD, containing 8A. 1R. 24P., part off 2A. 1R. 32P. by a line parallel to AD = 700 links. Then, from the remainder of the rectangle, part off 2A. 3R. 25P. by a line parallel to AB.

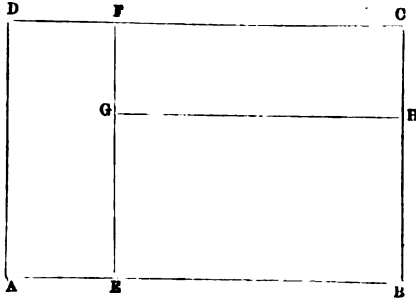

sq. links.  
 2A. = 200000  
 1R. = 25000  
 32P. = 20000  

---

 7,00) 2450,00  
 .350 links, the side AE or DF.



$$\begin{array}{r}
 \text{sq. links.} \\
 8\text{A.} = 800000 \\
 1\text{R.} = 25000 \\
 24\text{P.} = 15000 \\
 \hline
 7,00)8400,00 \\
 \quad 1200 \text{ links, the side AB} \\
 \quad \quad 350 \text{ — the side AE} \\
 \quad \quad \quad 850 \text{ — the difference = EB} \\
 \quad \quad \quad \hline
 \end{array}$$

$$\begin{array}{r}
 \text{sq. links.} \\
 2\text{A.} = 200000 \\
 3\text{R.} = 75000 \\
 25\text{P.} = 15625 \\
 \hline
 850)290625(342 \text{ links, the side EG or BH} \\
 \quad 2550 \\
 \quad \hline
 \quad \quad .3562 \\
 \quad \quad \quad 3400 \\
 \quad \quad \quad \hline
 \quad \quad \quad \quad .1625 \\
 \quad \quad \quad \quad \quad 1700 \\
 \quad \quad \quad \quad \quad \hline
 \end{array}$$

3. Part off 6A. 3R. 12P. from a rectangle containing 15A. by a line parallel to the longer side, the shorter being 1000 links.

*Ans.* The longer side of the given rectangle is 1500, and the shorter side of the rectangle required is 455 links.

### PROBLEM XII.

*To part from a square or rectangle any proposed quantity of land, either in a right-angled triangle or trapezoid, by a line drawn from any of the angles to either of the opposite sides.*

**RULE.**—When the proposed area is to be parted off in a triangle, divide double this area by the base or side upon which it is to be parted off, and the quotient will be the perpendicular.

When the proposed area is to be parted off in a trapezoid, subtract it from the area of the square or rectangle, and part off the remainder in a triangle, as above directed.

#### *Examples.*

1. From ABCD, representing a square whose side is 900 links, part off a triangle which shall contain 2A. 1R. 36P. by a line drawn from the angle B to the side AD.

$$2\text{A. 1R. 36P.} = 247500 \text{ square links}$$

$$\begin{array}{r}
 \quad \quad \quad 2 \\
 9,00)4950,00 \\
 \hline
 \end{array}$$

550 links, the perpendicular AE.

Hence ABE is the triangle required.

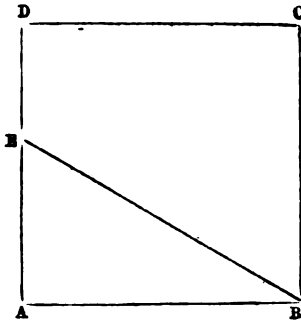

2. From ABCD, representing a rectangle whose length is 1265 and breadth 758 links, part off a trapezoid which shall contain 7A. 3R. 24P. by a line drawn from the angle B to the side CD.

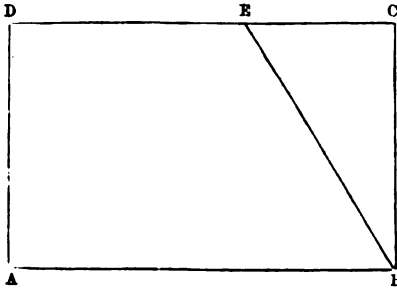

	sq. links
958870	the area of the rectangle
790000	ditto of the trapezoid
168870	difference, the area of the triangle
2	
337740	(445.5 links, the perpendicular CE.
3032	Hence ABED is the trapezoid required
.3454	
3032	
.4220	
3790	
.4300	
3790	
.510	

3. From a rectangular field, whose length is 1560 and breadth 1000 links, it is required to part off a trapezoid which shall contain

P

12A. 3R. 12P. by a line drawn from any of the angles to the longer opposite side.

*Ans.* The area of the rectangle is 15A. 2R. 16P.; consequently the area of the triangle is 2A. 3R. 4P., and its perpendicular 555 links.

### PROBLEM XIII.

*To part from a triangle, upon the base or longest side, any proposed quantity of land by a line drawn from either of the angles at the base to the opposite side.*

**RULE.**—Divide twice the proposed area by the base upon which it is to be parted off, and the quotient will be the perpendicular.

Or, if the proposed area be divided by half the base, the quotient will be the perpendicular.

**NOTE.**—A parallel ruler may be used with advantage in this and several of the following problems.

#### *Examples.*

1. From ABC, representing a triangle whose base AB is 1200, and sides AC and BC 1000 and 800 links respectively, part off 2A. 2R. 24P. by a line drawn from the angle B to the side AC.

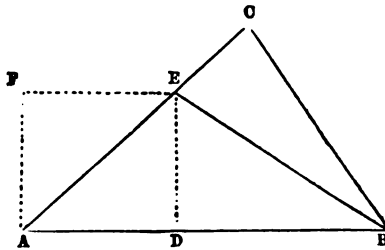

2A. 2R. 24P. = 265000 square links

$$\begin{array}{r} 2 \\ 12,00 \overline{) 5300,00} \end{array}$$

441·6 links, the perpendicular DE.

At A erect the perpendicular AF, which make = 441·6 links; then draw FE parallel to AB, and it will intersect the side AC in the point to which the division-fence BE must be made.

Or, by the plotting scale, erect the perpendicular DE = 441·6 links, which will determine the point E.

By the scale you will find AE = 664 links; measure, therefore, in the field, 664 links from A to E; stake out the line BE, and ABE will be the triangle required.

2. From ABC, representing a triangle whose base AB is 1300, and sides BC and AC 1100 and 900 links respectively, part off 1A. 3R. 36P.

by a line drawn from the angle A to the side BC, so that the triangle AEC may contain the proposed quantity.

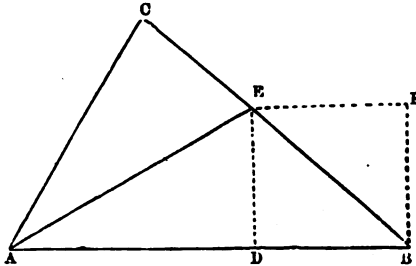

From the three sides, by Note 4, Part IV., the area of the given triangle is found = 488076 square links

and 1A. 0R. 36P. = 197500 square links

The difference = 290576, the area of the triangle ABE

$$\begin{array}{r}
 2 \\
 1300 \overline{)581152} (447 \text{ links, the perpendicular DE.} \\
 \underline{5200} \\
 .6115 \\
 \underline{5200} \\
 .9152 \\
 \underline{9100} \\
 \dots 52
 \end{array}$$

By the mode described in the last example, determine the point E, which you will find at the distance of 658 links from the angle B; measure this distance in the field from B to E, and proceed as before.

3. From a triangular field whose sides are 1500, 1200, and 1000 links respectively, part off 3A. 2R. 16P. by a fence made from the greater angle at the base to the opposite side.

*Ans.* The perpendicular of the triangle required is found to be 480 links; and it rises upon the base at the distance of 537 links from the less angle.

#### PROBLEM XIV.

*To part from a triangle any proposed quantity of land by a line parallel to any one of its sides.*

**RULE.**—The areas of similar triangles are to one another in the duplicate ratio of their homologous sides; hence, as the area of the triangle ABC is to the square of the side AC, or BC, so is the area of the triangle DEC to the square of the side DC, or EC. (See Theo. XIII. Part I.)

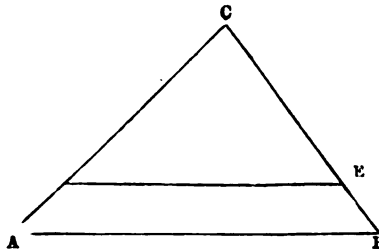
*Examples.*

1. Suppose the base  $AB = 1200$ , the side  $AC = 1000$ , and the side  $BC = 800$  links ; part off 1A. 2R. 16P. by the line  $DE$  parallel to  $AB$ .

From the three sides, by Note 4, Part IV., we find the area of the triangle

$$ABC = 396863 \text{ square links}$$

$$\text{and 1A. 2R. 16P.} = 160000 \text{ square links}$$

$$\text{The difference} = \underline{236863}, \text{ the area of the triangle DEC.}$$

Then, as  $396863 : 1000 \times 1000 :: 236863 : 596838\cdot20$ ; and  $\sqrt{596838\cdot20} = 772\cdot5$  links =  $DC$ ; hence  $1000 - 772\cdot5 = 227\cdot5$  links =  $AD$ . Again, as  $396863 : 800 \times 800 :: 236863 : 381976\cdot45$ ; and  $\sqrt{381976\cdot45} = 618$  links =  $EC$ ; then  $800 - 618 = 182$  links =  $BE$ .

Measure therefore in the field  $227\cdot5$  links from  $A$  to  $D$ ; and from  $B$  to  $E$  measure  $182$  links; stake out the line  $DE$ , and the work will be completed.

2. From a triangular field, whose sides are  $1800$ ,  $1500$ , and  $1200$  links respectively, part off 3A. 2R. 32P. by a line parallel to the shortest side.

*Ans.* The area of the given triangle is  $892941$  square links; the area of the triangle made by the line of division is  $522941$  square links; and one of its sides from the angle opposite the line of division to the commencement of that line, is  $1147\cdot9$ , and the other  $1377\cdot4$  links.

## PROBLEM XV.

*To part from a rectangle or triangle any proposed quantity of land upon a line on which there are offsets, when the area of those offsets is to be considered as part of the portion to be parted off.*

**RULE.**—Find the area of the offsets, which subtract from the portion to be parted off, and then proceed with the remainder as directed in the preceding problems.

But, in a rectangle, when there are offsets on one or both of the lines adjoining that upon which the given quantity is to be parted off, reject these offsets and proceed as before directed.

Then, having found the distance at which the line of division must be from that upon which the given quantity is to be parted off, find the area of the offsets contained between those lines, which area divide by the latter line, and the quotient will be the distance by which the former line must be approximated to the latter.

*Examples.*

1. From a rectangular field whose dimensions are contained in the following notes, part off 2A. 3R. 32P, upon the chain-line AB, so that the offsets taken upon that line may be included.

DA	
560	
L. off D	
CD	
1200	
1000	
L. off C	
BC	
560	
L. off B	
AB	
1200	0
1000	
900	60
600	80
300	50
000	0
Begin at	range E.
A	

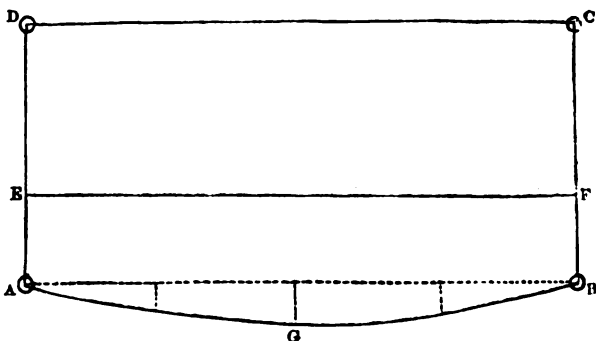

sq. links  
 2A. 3R. 32P. = 295000  
           57000 the area of the offsets  
 12,00)2380,00 the difference  
       198·4 links = AE, or BF.

Hence the irregular figure AGBFE contains 2A. 3R. 32P.

2. From a rectangular field whose dimensions are contained in the following notes, part off 2A. 2R. 8P. by a line parallel to the chain-line AB, so that the offsets taken upon this line, and also those upon the two adjoining lines contained between the chain-line AB and the line of division may be included.

	DA
0	500
40	350
55	250
45	150
0	000
	R. off D
	CD
	1000
	R. off C
	BC
0	500
40	400
60	250
45	150
0	000
	R. off B
	AB
0	1000
50	700
70	450
40	200
0	000
Begin at	A
	range W.

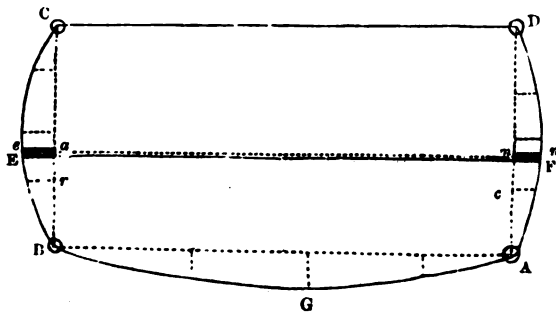

sq. links  
 2A. 2R. 8P. = 255000  
 40250 the area of the offsets taken on AB  
 1,000)214,750 the difference  
 214·750 links = Ba or Am, which we may call 215  
 links. Now, 215 - 150 = 65 = ra = om; and, by the scale, ae

is found to measure 58, and  $mn$  53 links; hence the area of the offset  $Bae$  + the area of the offset  $Amn = 13282$ , which, divided by 1000, gives 13 links, the distance by which the line  $en$  must be approximated to  $AB$ . Consequently,  $EF$  is the true line of division; and the regular figure  $AGBEF$  contains 2A. 2R. 8P. minus the two shaded offsets.

### PROBLEM XVI.

*To part from a trapezium, or any irregular polygon whatever, any proposed quantity of land by a line drawn parallel to any of the sides, or by a line drawn from any of the angles, or from any assigned point in one of the sides to any of the opposite sides.*

RULE 1. Having laid down the whole figure, draw a guess-line in the direction required, parting off, as nearly as can be judged, the proposed quantity; after which, by the scale, measure, with the greatest accuracy, the guess-line, and also the quantity thus parted off.

Then, if the guess-line or line of division be drawn from an angle, or from any assigned point in a side, divide the difference between the proposed quantity and the quantity parted off, by half the guess-line, and the quotient will be the perpendicular to be set off, on one side, or the other, of the guess-line, accordingly as the quantity parted off is more or less than the quantity proposed. To the end of this perpendicular, from the point assigned, draw a new line of division, and it will part off the quantity required.

2. But if the guess-line be drawn parallel to any of the sides, divide the difference before mentioned by the whole guess-line, and the quotient will be the perpendicular to be set off from each end of the guess-line, on one side, or the other, as above.

NOTE 1. When from a trapezium, approaching very nearly to a rectangle, it is required to part off any number of acres, &c., by a line parallel to one of its sides, it may be done as directed in Problem XI.; and if there be offsets upon any of the lines, they must be treated as in the last problem.

2. In using guess-lines, it is not necessary that the learner should draw them so as to coincide in measure with those of the examples which he is performing. It will be sufficient for him to proceed in a similar manner.

#### *Examples.*

1. From a trapezium whose dimensions are contained in the following notes, part off 2A. 2R. 24P. by a line parallel to the side  $AB$ .

BD
1249
1000
return to B

diag.



	diag.
AC	1112
	1000
R. off A	
DA	550
R. off D	
CD	979
R. off C	
BC	557
R. off B	
AB	1114
	1000
Begin at	A
	range W.

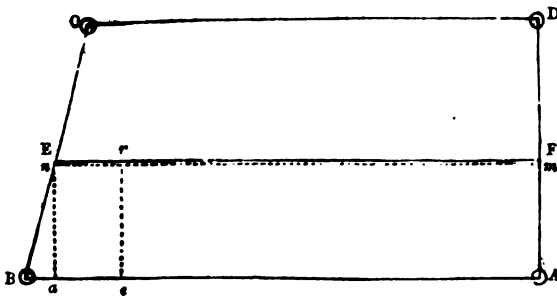

Having laid down the figure, draw the guess-line  $mn$  parallel to  $AB$ ; and from  $n$  let fall the perpendicular  $an$ ; then, suppose  $mn = 1058$  links,  $an$  will be  $= 230$ , and  $aA = 1052$  links; therefore,  $Ba = 1114 - 1052 = 62$  links.

sq. links

Then,  $1055 \times 230 = 242650$  the area of the trapezoid  $Aanm$

and  $230 \times 31 = 7130$  the area of the triangle  $Ban$

The sum  $= 249780$  the area of the trapezium  $ABnm$

2A. 2R. 24P. = 265000

15220

the difference between the quantity proposed and the quantity parted off by the guess-line; which, divided by 1058, gives 14.4 links to be set off perpendicularly from  $m$  and  $n$  toward  $D$  and  $C$ . Hence,  $EF$  is the true line of division and the trapezium  $ABEF$  contains 2A. 2R. 24P.

As  $A$  is very nearly a right angle, measure in the field  $230 + 14.4 = 244.4$  links from  $A$  to  $F$ . Then, upon any part of the line  $AB$ , (toward  $B$ ) as at  $e$ , erect the perpendicular  $er$ , which make  $= 244.4$  links; stake out the line  $ErF$ , and the work will be completed.

2. From a trapezium whose dimensions are contained in the following notes, part off, in a triangle, 1A. 3R. 12P. by a line drawn from the angle  $C$  to the side  $AB$ .

BD 1634 1000 return to B	diag.
AC 1010 L. off A	diag.
DA 620 L. off D	
CD 1010 L. off C	
BC 820 L. off B	
AB 1300 1000 A	range E.

Begin at

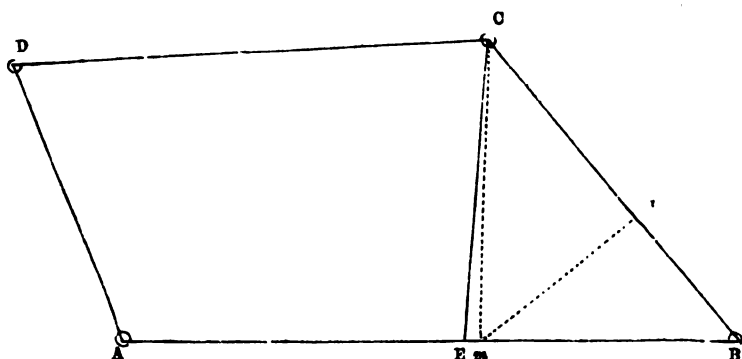

Having laid down the figure, draw the guess-line  $Cm$ , which suppose  $= 638$  links. From  $m$  let fall the perpendicular  $ma$ , which will be  $= 417$  links.

sq. links

Then,  $410 \times 417 = 170970$  the area of the triangle  $BCm$ 

1A. 3R. 12P. = 182500

11530 the difference between the quantity proposed and the quantity parted off by the guess-line, which divided by 319 (half the guess-line) gives 36 links, to be set off from  $m$  towards A. Hence,  $EC$  is the true line of division; and the triangle  $BCE$  contains 1A. 3R. 12P.

Also,  $AE$  is found = 731 links: measure, therefore, in the field 731 links from A to E; stake out the line  $EC$ , and the work will be completed.

NOTE.—The rules given in this problem for parting off land from irregular figures are generally adopted by practical surveyors, because they may be applied to any irregular figure whatever. Land, however, may sometimes be parted off more directly: for instance, the foregoing example may be performed by the mode followed in Problem XIII, i.e. if the given quantity, in square links, be divided by half the line  $BC$ , the quotient will be the perpendicular of the triangle  $BCx$ ; then, at the distance of this perpendicular, a line drawn parallel to  $BC$  will intersect the line  $AB$  in  $x$ , the point to which the division-fence must be made.

3. From a field whose dimensions are contained in the following notes, part off 3A. 2R. 16P. toward  $AD$ , by a fence made from the side  $AB$  to the side  $CD$ , so that the fence may commence at the distance of 600 links from A.

BD	
1050	diag.
return to B	
AC	diag.
1708	
1000	
L. off A	
DA	
790	
L. off D	
CD	
1130	
1000	
L. off C	
BC	
640	
L. off B	
AB	
1320	
1000	
Begin at A	range E.

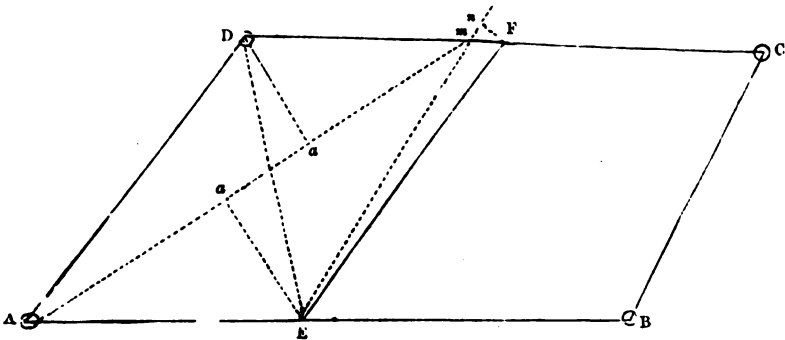

Having constructed the figure, set off 600 links from A to E, and draw the guess-line  $Em$ , which suppose = 702 links; the diagonal  $Am$  will be = 1132, the perpendicular  $Da = 278$ , and the perpendicular  $Ea = 318$  links. Hence, the area of trapezium  $ADmE$  is found = 337336 square links; but the quantity proposed (360000 square links) exceeds the quantity parted off by 22664 square links: this divided by 351 (half the guess-line) gives 64.5 links, to be set off from the line  $Em$ , perpendicularly toward BC.

Now, continue the line  $Em$ , and upon it erect the perpendicular  $nF = 64.5$  links. The line  $FE$  will be the true line of division; and the trapezium  $ADFE$  contains 3A. 2R. 16P.

If it had been required to set off the perpendicular on the other side of the line  $Em$ , you must still have erected it so that its end might have touched the line  $CD$ .

Now, by the scale  $DF$  is found = 553 links. Measure, therefore, in the field 600 links from A to E, and 553 from D to F; stake out the line  $FE$ , and the work will be completed.

NOTE.—The last example may also be performed by finding the area of the triangle  $ADE$ , and subtracting it from the given quantity; then, if the remainder be divided by half the line  $DE$ , the quotient will be the perpendicular of the triangle  $DEF$ .

At the distance of this perpendicular, draw a line parallel to  $DE$ , and it will intersect the line  $CD$  in  $r$ , the point to which the division fence must be made.

4. From an irregular field whose dimensions are contained in the following notes, part off 2A. 3R. 20P. toward the line  $AE$ , by a fence made from the angle D to the side  $AB$ .

EB
1398
1000
R. off E

diag.

	CE	
	1240	diag.
	1000	
	500	<i>m</i> , proof-line, goes to D,
	R. off C	and measures 324
	AC	
	1260	diag.
	1000	
	R. off A	
0	EA	
	400	
80	200	
0	000	
	R. off E	
	DE	
0	600	
25	450	
35	300	
20	150	
0	000	
	R. off D	
	CD	
	740	
	R. off C	
	BC	
	550	
	R. off B	
0	AB	
	1250	
35	1000	
50	800	
60	600	
50	400	
30	200	
0	000	
Begin at	A	range W.

Having laid down the figure, draw the guess-line  $Dn$ , which suppose = 766 links; then the diagonal  $AD$  will be = 824, the perpendicular  $Ea$  = 278, and the perpendicular  $ra$  = 372 links;  $re$  also will be = 228, and  $rn$  = 52 links.

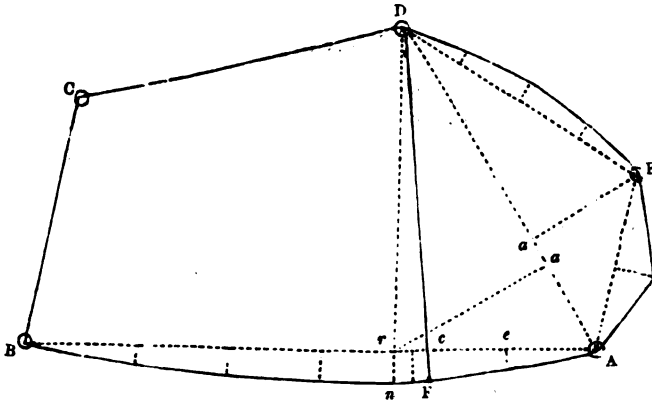

sq. links

267800 the area of the trapezium  $A\tau DE$

12000	}	DE	{	the area of the offsets taken on the different lines
16000		EA		
12348		$A\tau$		

308148 the area of the irregular figure  $A\tau DE$

2A. 3R. 20P. = 287500

20648 the difference between the quantity proposed and the quantity parted off by the guess-line, which divided by 383 (half the guess-line) gives 54 links, to be set off from  $n$  toward A. Hence  $DF$ , is the true line of division; and the irregular figure  $AFDE$  contains 2A. 3R. 20P.

Now, by the scale,  $Ac$  is found = 377 links. Measure, therefore, in the field 377 links from A to  $c$ ; stake out the line  $DcF$  and the work will be completed.

NOTE 1. If the area of the irregular figure  $ADE$  be subtracted from the given quantity, and the remainder divided by half the line  $AD$ , the quotient will be the perpendicular of the triangle  $ADF$ ; the side  $AB$  being nearly straight from A to  $F$ .

Now, at the distance of this perpendicular, draw a line parallel to  $AD$ , and it will intersect the side  $AB$  in  $F$ , the point to which the division-fence must be made.

2. It is not absolutely necessary to survey and plan a whole field in order to part a portion from it, as the guess-line and portion parted off may be measured in the field; but, in my opinion, the former, in general, is a more eligible method than the latter, as you have a better opportunity of proving your work.

## SECTION II.

*The method of dividing a piece of land among sundry claimants, in the proportion of their respective claims, or a common, &c., of variable value, among any number of proprietors, in the proportion of their respective interests.*

When land becomes the property of co-heirs, co-partners, joint purchasers, &c., it is generally divided into such shares as the co-parties are entitled to; and this cannot possibly be accurately effected without the assistance of some person who is not only well acquainted with surveying, but also with the method of apportioning land.

In this process an error is evidently much more material than one committed in surveying.—When a field, &c., is to be divided into any number of parts, equal or unequal, it is necessary, first, to ascertain its dimensions, and next to enquire of the parties concerned in what part of the property in question they wish their respective shares to lie.

## PROBLEM I.

*To divide a square or rectangle, either equally or unequally among any number of persons, by lines parallel to one of its sides.*

RULE.—If the parts into which the field is required to be divided be equal, divide the side which will be cut by the division-fences by the number of those parts, and the quotient will be the distance at which the division-fences must be placed from each other, and from the outsides to which they are parallel. But, if the parts be unequal, you must then part off each person's share as directed in Section I. Problem XI.

*Examples.*

1. Divide the square ABCD containing 5A. 2R. 20P. into three equal parts by fences parallel to the side AB.

Here 5A. 2R. 20P. = 562500 square links; and  $\sqrt{562500} = 750$  links, the side of the square. This, divided by 3, the number of parts, gives 250 links, the distance at which the first division-fence must be placed from AB, &c. From A and B, therefore, set off 250 links to E and F; join EF, and the rectangle ABFE will be one of the parts required.

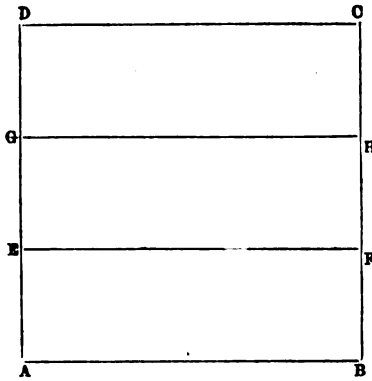

Again, from E and F set off 250 links to G and H; join GH, and the rectangles EFGH and GHCD will be the two other parts required.

2. Divide ABCD, representing a rectangular field whose length is 1500 and breadth 800 links, among three men, A, B, and C, by fences parallel to the side AD, so that A may have 3A., B 4A., and C the remainder

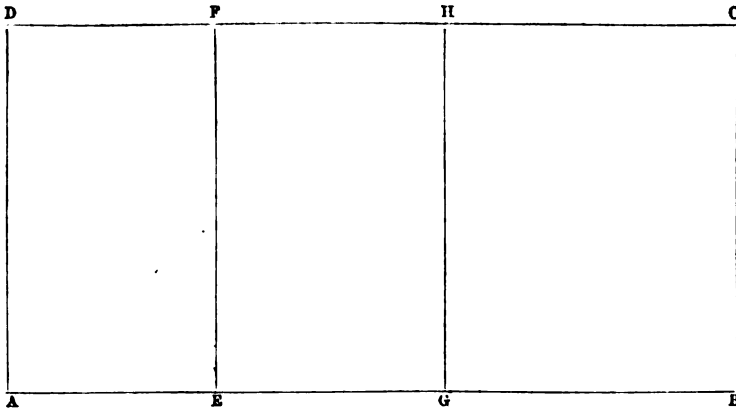

Here  $3A. = 300000$  square links, which divided by 800 gives 375 links = AE or DF; hence the rectangle AEFD contains A's share.

Again,  $4A. = 400000$  square links, which divided by 800 gives 500 links = EG or FH; hence the rectangle EGHF contains B's share.

Now, the rectangle ABCD is found to contain  $12A.$ , consequently, the rectangle GBCH, containing  $5A.$ , is C's share.



NOTE.—This and similar examples may also be performed by the following proportion: As the area of the whole rectangle is to the whole base or side cut by the division-fences, so is each person's share of the rectangle to his share of the base.

### PROBLEM II.

*To divide a triangular field, either equally or unequally, among any number of persons, by fences made from any of its angles to the opposite side.*

RULE.—If the parts into which the field is required to be divided be equal, divide the base or side to which the division-fences are to be made by the number of those parts, and the quotient will be each person's share of the base. But, if the parts be unequal, say, as the area of the whole triangle is to the whole base, so is each person's share of the triangle to his share of the base. (See Simpson's Geom. IV. 7, and Euclid VI. 1.)

#### *Examples.*

1. Divide ABC, representing a triangular field whose sides AB, AC, and BC are 1500, 1200, and 1000 links respectively, into three equal parts, by fences made from the angle C to the side AB.

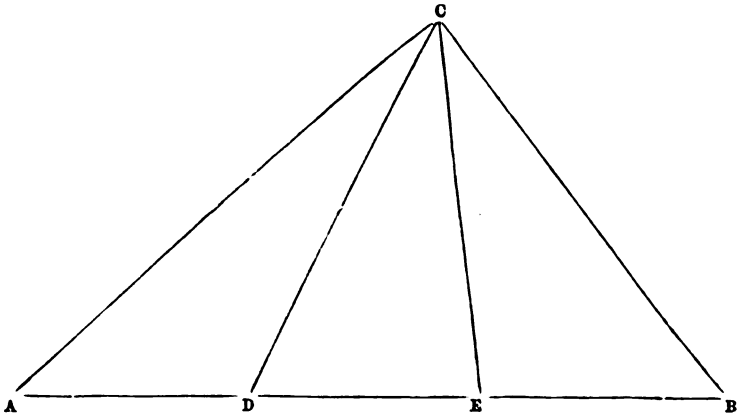

Here  $AB = 1500$  links, which divided by 3 (the number of parts) gives 500 links, each person's share of the base. From A, therefore, set off 500 links to D, and from D 500 links to E; draw the lines CD and CE, to represent the division-fences; and the triangles ADC, DEC, and EBC, are the three equal parts required.

2. Divide  $\triangle ABC$ , representing a triangular field whose sides  $AB$ ,  $AC$ , and  $BC$  are 1450, 1150, and 960 links respectively, into three equal parts, by fences made from the angle  $A$  to the side  $BC$ .

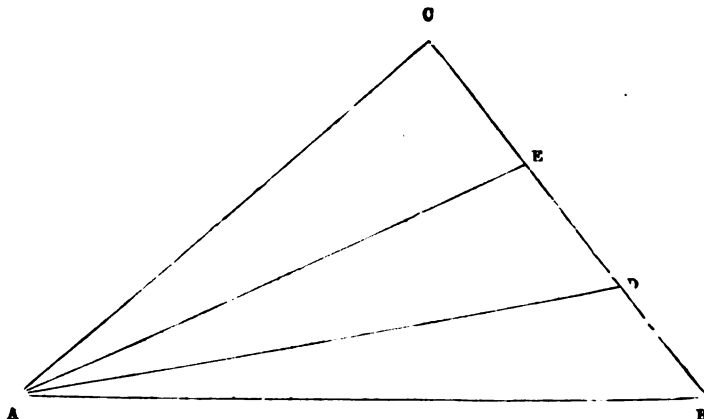

Here  $BC = 960$  links, which divided by 3 (the number of parts) gives 320 links, each person's share of the side  $BC$ . From  $B$ , therefore, set off 320 links to  $D$ , and from  $D$  set off the same distance to  $E$ ; and the lines  $AD$  and  $AE$  will be the lines of division required.

3. Divide  $\triangle ABC$ , representing a triangular field whose sides  $AB$ ,  $AC$ , and  $BC$  are 2200, 1700, and 1500 links respectively, among three persons  $A$ ,  $B$ , and  $C$ ; so that, each person partaking of a pond at  $C$ ,  $A$  may have  $3A$ ,  $B$   $4A$ , and  $C$  the remainder.

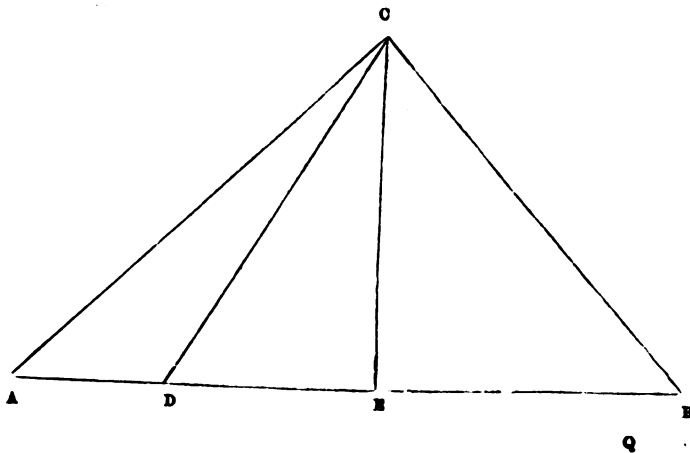

Having the three sides of the triangle, we find its area = 1272792·2 square links ; then, as  $1272792·2 : AB = 2200 : : A's\ share = 300000\ square\ links : 518·5\ links,$  A's share of the base.

Again, as  $1272792·2 : 2200 : : 400000 : 691·3\ links,$  B's share of the base.

The remainder of the base, which is 990·2 links, belongs to C ; and deducting 7A., the sum of A's and B's shares, from the area of the whole triangle, we find remaining for C's share 572792·2 square links = 5A. 2R. 36 P.

From A, therefore, set off 518·5 links to D, and from D set off 691·3 links to E ; and the lines CD and CE will be the lines of division required.

### PROBLEM III.

*To divide a triangular field, either equally or unequally, among any number of persons, by fences proceeding from any assigned point in one of its sides.*

**RULE.**—Divide the base or side of the triangle from which the division-fences are to be run, as directed in the last problem. From the assigned point, draw a line to the opposite angle ; and parallel to this line draw a line from each point of division on the base, until it intersects the opposite side. From these points of intersection draw lines to the point assigned, and they will be the lines of division required. (See Dr Hutton's Course of Mathematics, vol. iii. chap. 7, prob. 2.)

#### *Examples.*

1. Divide ABC, representing a triangular field, whose sides AB, BC, and AC are 1500, 1150, and 950 links respectively, equally among three persons, by fences proceeding from a gate, 700 links distant from A on the base, leading into a lane, through which alone a road can be had to the field.

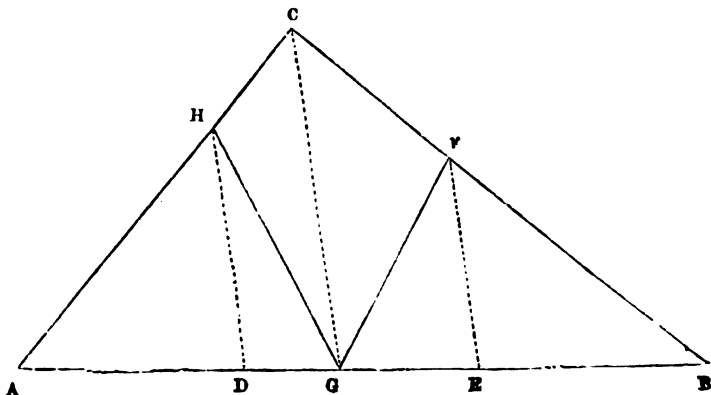

By the question  $AB = 1500$  links, divided by 3, gives 500 links, each person's share of the base. From A, therefore, set off 500 links to D, and from D set off the same extent to E. Then from the gate G draw the line GC; and, parallel to it, the lines DH and EF. From H and F draw the lines HG and FG, and they will be the fences of division required.

Now, by similar triangles (Theo. XI., part I.), as  $AG : AC :: AD : AH = 678.5$  links; and as  $BG : BC :: BE : BF = 718.7$  links. Measure, therefore, in the field, 678.5 links from A to H, and 718.7 from B to F; stake out the lines HG and FG, and the work will be completed.

NOTE.—After the points H and F have been determined, by the parallel ruler, the lines AH and BF may be measured by the scale.

2. Divide ABC, representing a triangular field whose sides AB, AC and BC are 1400, 1200, and 1000 links respectively, among three persons, A, B, and C, by fences proceeding from a pond which is at the distance of 600 links from A on the base, so that each person partaking of the pond, A may have 1A. 2R. 10P., B 1A. 3R. 20P., and C the remainder.

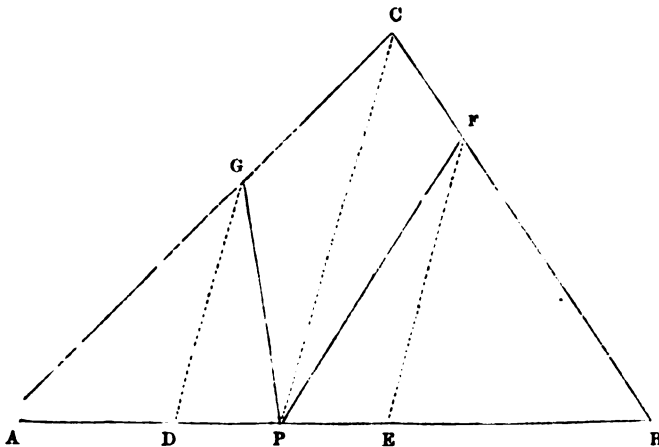

Having the three sides of the triangle, we find its area = 587877.5 square links. Then, as  $587877.5 : AB = 1400$  : A's share = 156250 square links : 372 links, his share of the base.

Again, as  $587877.5 : 1400 :: 187500 : 446.5$  links, B's share of the base.

From A, therefore, set off 372 links to D, and from D set off

446·5 to E. Then from the pond P draw the line PC, and parallel to it the lines DG and EF. From G and F draw the lines GP and FP; and the triangle APG will contain A's share; the trapezium PGCF, B's share; and the triangle BPF, C's share = 244127·5 square links = 2A. 1R. 30P.

By similar triangles we find  $AG = 744$ , and  $BF = 726·8$  links; proceed, therefore, in the field, as directed in the last example.

#### PROBLEM IV.

*To divide a triangular field, either equally or unequally, among any number of persons, by fences made parallel to one of its sides.*

**RULE.**—By the rule given in Section I., Problem XIV., part off the first person's share; proceed with the remainder of the triangle, and the next person's share in the same manner, and thus continue till the whole triangle is divided.

#### *Examples.*

1. Divide ABC, representing a triangular field whose sides AB, AC, and BC, are 1500, 1200, and 1000 links respectively, into three equal parts by fences made parallel to the side BC.

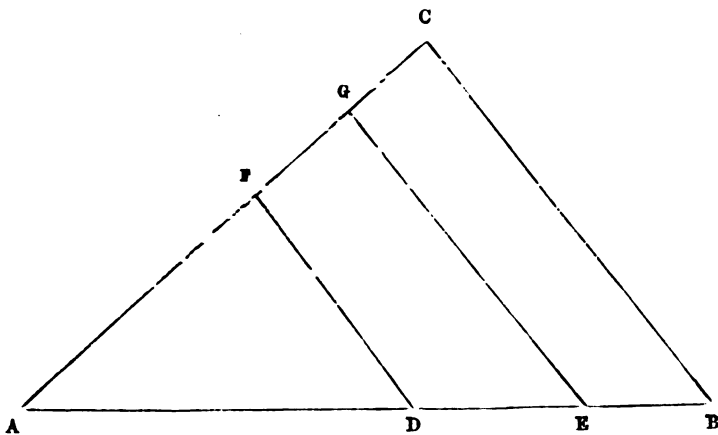

The area of the given triangle is found = 598116·9 square links, which divided by 3 gives 199372·3 square links for each person's share; consequently, 398744·6 square links is the area of the triangle AEG.

Then, as  $598116·9 : 1500 \times 1500 :: 398744·6 : 1500000$ ; and  $\sqrt{1500000} = 1224·7$  links = AE.

And as  $598116·9 : 1200 \times 1200 :: 398744·6 : 960000$ ; and  $\sqrt{960000} = 979·8$  links = AG.

Again, as  $398744\cdot6 : 1224\cdot7 \times 1224\cdot7 :: 199372\cdot3 : 749945\cdot04$  ;  
and  $\sqrt{749945\cdot04} = 865\cdot9$  links = AD.

And as  $398744\cdot6 : 979\cdot8 \times 979\cdot8 :: 199372\cdot3 : 480004\cdot02$  ; and  
 $\sqrt{480004\cdot02} = 692\cdot8$  links = AF. Hence the triangle ABC is  
divided into three equal parts, as required.

2. Divide ABC, representing a triangular field whose sides AB, BC, and AC are 2200, 1700, and 1500 links respectively, among three persons, A, B, and C, by fences made parallel to the base AB, so that A may have 3A., B 4A., and C the remainder.

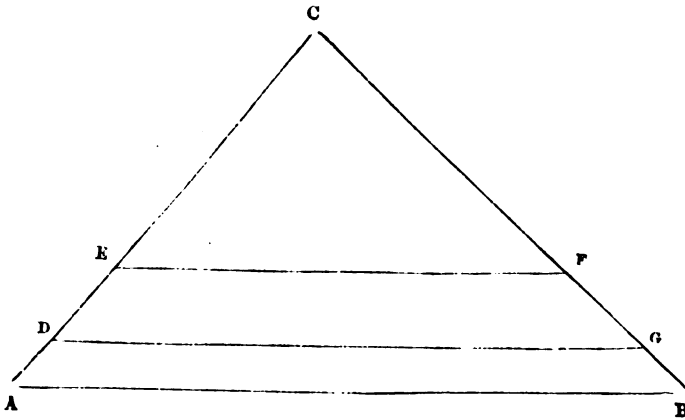

The area of the triangle ABC is found = 1272792·2 square links, from which taking 300000 square links (= A's share) we leave 972792·2 square links, the area of the triangle DGC. From this taking 400000 square links (= B's share), we leave 572792·2 square links, the area of the triangle EFC = 5A. 2R. 36P. = C's share.

Then, as  $1272792\cdot2 : 1700 \times 1700 :: 972792\cdot2 : 2208820\cdot46$  ; and  
 $\sqrt{2208820\cdot4} = 1486\cdot2$  links = CG.

And, as  $1272792\cdot2 : 1500 \times 1500 :: 972792\cdot2 : 1719669\cdot91$  ; and  
 $\sqrt{1719669\cdot91} = 1311\cdot3$  links = CD.

Again, as  $972792\cdot2 : 1486\cdot2 \times 1486\cdot2 :: 572792\cdot2 : 1300563\cdot40$  ;  
and  $\sqrt{1300563\cdot40} = 1140\cdot4$  links = CF.

And, as  $972792 : 1311\cdot3 \times 1311\cdot3 :: 572792\cdot2 : 1012467\cdot60$  ; and  
 $\sqrt{1012467\cdot60} = 1006\cdot2$  links, = CE. Hence the triangle ABC is  
divided into three parts, as required.

## PROBLEM V.

To divide a trapezium, or an irregular polygon, equally or unequally, among any number of persons, by fences made in a given direction.

RULE.—By the rules given in Section I. Problem XVI. part off the first person's share; proceed with the remainder of the figure, and the second person's share in the same manner: and thus continue till the whole figure is divided.

*Examples.*

1. Divide a trapezium, whose dimensions are contained in the following notes, into three equal parts, by fences made from the side AB to the side CD.

BD	
1542	diag.
1000	
return to B	
AC	
1848	diag.
1000	
R. off A	
DA	
915	
R. off D	
CD	
1347	
1000	
R. off C	
BC	
885	
R. off B	
AB	
1547	
1000	
A	range W.

The area of the triangle ABC is found = 681942, and the area of the triangle CDA = 585949 square links; consequently the area of the trapezium ABCD = 1267891 square links, which divided by 3 gives 422630 square links for each person's share.

Now draw the guess-line  $em$ , which suppose = 880 links; then the diagonal  $EC$  will be found = 1028, the perpendicular  $Ca$  = 387, and the perpendicular  $ma$  = 424 links; hence the area of the trapezium  $BCmE$  is found = 416854 square links, which is too little by

5776 square links. This divided by 440 (half the guess-line) gives 13 links, to be set off from  $m$  toward  $D$ ; consequently  $EF$  is the true line of division.

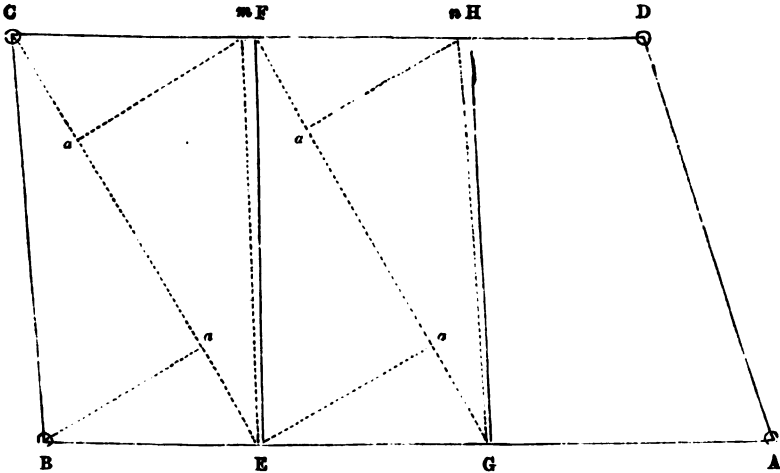

Again, draw the guess-line  $Cn$ , which suppose = 878 links; then will the diagonal  $GF = 1017$ , the perpendicular  $Ea = 430$ , and the perpendicular  $na = 385$ : hence the area of the trapezium  $EFnG$  is found = 414427 square links, which is too little by 3203 square links. This divided by 439 (half the guess-line) gives 19 links, to be set off from  $n$  toward  $D$ ; consequently  $GH$  is the true line of division; and the trapezium  $ABCD$  is divided into three equal parts, as required.

Now, by the scale, we find  $BE = 450$ ,  $EG = 500$ ,  $CF = 508$ , and  $FH = 468$  links, which distances must be measured in the field, in order to determine the situation of the division-fences.

NOTE.—If we subtract the area of the triangle  $BCF$  from the quantity to which each person is entitled, and divide the remainder by half the line  $CE$ , the quotient will be the perpendicular of the triangle  $CEF$ . By drawing a line parallel to  $CE$ , at the distance of this perpendicular, the point  $F$  may be determined.

In a similar manner may be parted off the trapezium  $EFnG$ .

2. Divide a field, whose dimensions are contained in the following notes, among three persons,  $A$ ,  $B$ , and  $C$ , so that each partaking of a pond at  $P$ ,  $A$  may have  $3A$ ,  $B$   $4A$ , and  $C$  the remainder.

BD
1447
1000
R. off B

diag.



EB 1603 1000 R. off E	diag.
CE 1300 1000 R. off C	diag.
AC 1320 1000 700 R. off A	diag. pond
EA 750 R. off E	
DE 650 R. off D	
CD 850 R. off C	
BC 800 R. off B	
AB 1200 1000 A	range W.

From the pond P draw the line PD and also the guess-line  $Pm$ , which suppose = 558 links; then will the diagonal  $Dm$  be = 1025, the perpendicular  $Pa = 400$ , and  $Ca = 195$  links; hence the area of the trapezium  $PmCD$  is found = 304937 square links, which exceeds A's share by 4937 square links. This divided by 279 (half the guess-line) gives 17.7 links, to be set off from  $m$  toward C; consequently PF is the true line of division, and the trapezium PFCD contains A's share.

Again, draw the guess-line  $Pn$ , which suppose = 696 links, then the diagonal  $PE$  will be = 848, the perpendicular  $na = 247$  and  $Da = 552$  links; hence the area of the trapezium  $PnED$  is found = 338776 square links, which is less than B's share by 61224 square links. This divided by 348 (half the guess-line) gives 176 links to be set off from the line  $Pn$  perpendicularly toward A; consequently, PG is the true line of division, and the trapezium PGED contains B's share.

Now the irregular polygon ABFPG contains C's share, which will be found = 4A. 3R. 19P.

By the scale we find AG = 252, and BF = 545 links, which distances must be measured in the field, in order to determine the situations of the division-fences.

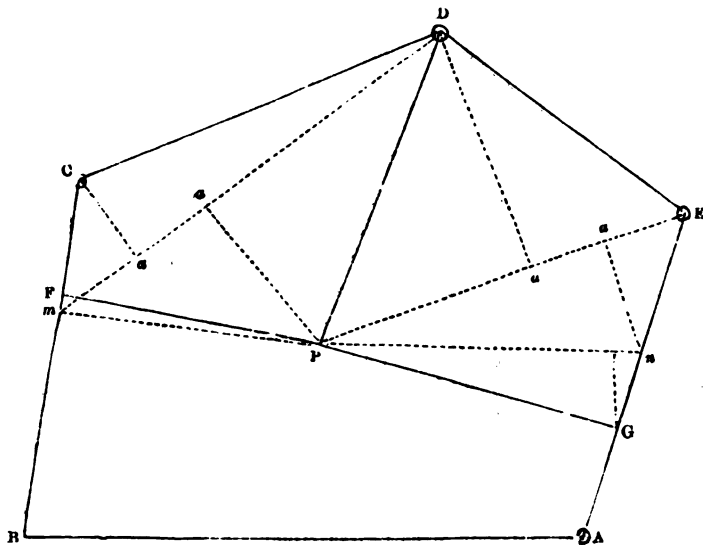

**NOTE 1.** The foregoing example may also be performed by subtracting the area of the triangle  $CDP$  from A's share, and then laying out the remainder in the triangle  $CDF$ , as before directed.

In a similar manner may be parted off B's share.

2. The division of the last, or any other figure, may be proved by finding the area of the whole figure, which, if equal, or nearly equal, to the sum of the areas of the parts into which it has been divided, demonstrates the work to be right.

#### PROBLEM VI.

*To divide a common, or any quantity of land, of uniform value, among any number of proprietors, in the proportion of their respective interests.*

In this case the land to be divided must first be surveyed, and next the estate of each proprietor, if its quantity be unknown. Then, if it be required to make the division according to the value of each person's estate, there must be proper persons appointed to value them, which, in this problem, we will suppose, may be done at so much per acre, uniformly, throughout each estate.

**NOTE 1.** When the land to be divided is of uniform value nothing more is wanted than its quantity.

2. It is immaterial whether the land be valued at 5s. or 5l. per acre, if the same proportion, according to the quality of the land, &c., be observed in valuing each person's estate.

*To determine each person's share.*

**RULE.**—As the number of acres, &c., contained in the sum of the estates, is to the whole quantity of land to be divided, so is each person's estate to his respective share. Or, as the sum of the values of all the estates is to the whole quantity of land to be divided, so is the value of each person's estate to his respective share.

*Examples.*

1. Divide a common containing 56A. 2R. 16P. among three persons, A, B, and C, whose estates are 58, 96, and 128A. respectively.

Here  $58 + 96 + 128 = 282$ , the number of acres contained in all the estates; and 56A. 2R. 16P. = 5660000 square links. Then,

$$\begin{array}{r} \text{A. sq. links} \\ \text{as } 282 : 5660000 :: \end{array} \left\{ \begin{array}{l} 58 \\ 96 \\ 128 \end{array} \right\} : \left\{ \begin{array}{l} 1164113 \\ 1926808 \\ 2569078 \end{array} \right\} = \left\{ \begin{array}{l} 11 \ 2 \ 22\cdot5 \\ 19 \ 1 \ 2\cdot8 \\ 25 \ 2 \ 30\cdot5 \end{array} \right\} \left. \begin{array}{l} \text{A's} \\ \text{B's} \\ \text{C's} \end{array} \right\} \text{share}$$

$$\begin{array}{r} \hline 5659999 \\ \hline \end{array} \qquad \begin{array}{r} \hline 56 \ 2 \ 15\cdot8 \text{ proof} \\ \hline \end{array}$$

Each person's share thus determined, the common may easily be divided by the methods already described.

2. Three gentlemen, A, B, and C, have each an estate consisting of 300A.; divide among them, according to the values of their estates, 75A. 3R. 32P.; A's estate being valued at 25s., B's at 32s., and C's at 40s. per acre per annum.

$$\text{Here } 300 \times \left\{ \begin{array}{l} 25 \\ 32 \\ 40 \end{array} \right\} = \left\{ \begin{array}{l} 7500 \text{ the value of A's estate} \\ 9600 \text{ ditto of B's} \\ 12000 \text{ ditto of C's} \\ \hline 29100 \text{ sum} \end{array} \right.$$

And 75A. 3R. 32P. = 7595000 square links. Then

$$\begin{array}{r} \text{s.} \\ \text{as } 29100 : 7595000 :: \end{array} \left\{ \begin{array}{l} 7500 \\ 9600 \\ 12000 \end{array} \right\} : \left\{ \begin{array}{l} 1957474 \\ 2505567 \\ 3131958 \end{array} \right\} = \left\{ \begin{array}{l} 19 \ 2 \ 12 \\ 25 \ 0 \ 9 \\ 31 \ 1 \ 11 \end{array} \right\} \left. \begin{array}{l} \text{A's} \\ \text{B's} \\ \text{C's} \end{array} \right\} \text{share}$$

$$\begin{array}{r} \hline 7594999 \\ \hline \end{array} \qquad \begin{array}{r} \hline 75 \ 3 \ 32 \text{ proof} \\ \hline \end{array}$$

**NORM.**—It sometimes happens that two, three, or more persons join in taking a common pasture, and agree to pay in proportion to the number of cattle with

which each person depastures. In such cases, when the whole of the cattle graze an equal time, you must make use of the rule of Single Fellowship, by saying, as the whole of the cattle is to the rent of the whole pasture, so is each person's cattle to his share of the rent. But when the cattle graze an unequal time, you must then have recourse to the rule of Double Fellowship, by saying, as the sum of the products of each person's cattle and time is to the whole rent, so is each person's product to his share of the rent.

### PROBLEM VII.

*To divide a common, &c., of variable value, among any number of proprietors, in proportion to their respective interests.*

In a work of this kind the quantity of every different quality is required, not only of the land to be divided, but also of each proprietor's estate; consequently the surveyor, accompanied by the persons appointed to value, generally called 'Commissioners,' must examine each person's estate, and also the common, previously to the survey being taken.

In doing this they must stake out lines between the different qualities of the soil; and, in surveying, these lines (called by surveyors 'quality-lines') must be considered as boundaries, and represented in the field-book, and upon the plan, by small dashes.

By way of distinction there ought to be two stakes put down at each angle formed by the quality-lines; and also marks cut in the ground, pointing in the direction of these lines, so that if the stakes should be pulled up, these marks may serve as directors.

When the survey is finished and laid down, every different quality represented upon the plan must be successively numbered, 1, 2, 3, &c. The surveyor must then require the commissioners to put the different valuations upon the land; and, in doing this, he must accompany them with the plan, in order that both he and they may know the ground corresponding with each number. Surveyors generally use letters to represent the different values of land:

Thus *a* may denote 1 shilling

<i>b</i>	„	„	2
<i>c</i>	„	„	3
<i>d</i>	„	„	4
<i>e</i>	„	„	5
<i>f</i>	„	„	6
<i>g</i>	„	„	7
<i>h</i>	„	„	8
<i>i</i>	„	„	9
<i>o</i>	„	„	10
<i>s</i>	„	„	20
and <i>x</i>	„	„	30 shillings

By putting three of these letters together, and adding their separate values, the value per acre per annum may be set down as high as sixty shillings; and, by adding more letters, it may be carried to any height required. By the use of these letters the confusion arising from a multiplicity of figures is avoided.

The land being valued, you must then proceed to find the quantity contained under each number on the plan, and also its value.

In doing this, it is unnecessary to bring the decimals into roods and perches, or to retain more of them than the three next the acres, as the operation is thus considerably simplified.

If the fourth figure in the decimals be 5, or greater, add 1 to the third: that is, if the content be 3·54585, set down 3·546.

When the content does not amount to an acre, and the number of figures is under five, add as many ciphers to the left as will complete that number: that is, if the content be ·8626, set down ·086. Then, multiply the acres and decimals, contained in each number, by the valuation per acre put upon the respective numbers, and the product will be the value in shillings and decimals. (See the note on page 54.)

#### MISCELLANEOUS OBSERVATIONS ON VALUING LAND.

1. Proprietors require to appoint judicious commissioners to value for an enclosure. They should not only be well acquainted with the quality of the soil, but should also be able to judge how far every part of the common is capable of being improved after it has been inclosed, or they will not be able to put a just valuation upon it.

2. In valuing, not only the quality of the land, but also its situation must be attended to; for, if one part of the land to be divided lies in a valley (not subject to be flooded), near a proprietor's messuage, and another part upon a hill, at the distance of two or three miles, it is evident, allowing the land to be all of the same quality, that the former situation is much more desirable than the latter; because it is nearer the homestead, and consequently better situated for agricultural purposes.

3. The manner in which the climate and seasons may operate upon the produce of the ground, in consequence of its local situation, should always be taken into consideration. If one field lies towards the south, and another towards the north, and both be of the same quality, the field that faces the south is more valuable than the other, as the crops on the former will not only be brought to a

greater degree of perfection by the influence of the sun, but will also be ready for harvesting sooner, and consequently may be brought to an earlier and frequently to a better market.

4. In valuing a common for an inclosure, the improvements that may be made by fencing, draining and cultivation, should never be overlooked. If one person should have an allotment awarded to him in the best part of the common, but where no improvement can be made, and another person's allotment, of equal value, be laid out in the worst part of the common, but where much improvement may easily be made by cultivation, it is manifest that the latter allotment will, in a few years, be more valuable than the former. Besides, as quantity is always given to compensate for any deficiency in quality, the proprietor who has his common-right laid out in the worst part of the ground, will not only receive more land than the other, but will soon be able, by a trifling expense in cultivation, to make it worth more per acre.

5. In valuing either old inclosed lands or commons, the distance of the ground from good springs of water should be regarded. In many parts of England, and particularly upon the Wolds in Yorkshire, the occupiers of land frequently suffer great inconvenience in driving their cattle a considerable distance to watering-places; and the cattle themselves are sometimes much injured in drougthy summers, for want of a regular supply of wholesome water. Hence a farm that is well watered is worth more to rent than another farm of equal quantity and quality, but destitute of water.

6. The distance of farms, common-rights, &c., from market-towns is also of considerable importance; because land always increases in value as it approaches the vicinity of large towns. Besides, as the means of tillage abounds in such places, improvements may be made at less expense than where the land lies at the distance of many miles. It may also be remarked that the occupiers of the former can always find a ready market for the produce of their land, while the occupiers of the latter are under the necessity of being at a considerable expense in transporting their goods to market, and in procuring the various articles that are indispensably necessary for the use of their families.

#### *Appellations given to certain lands.*

1. Moors are large, uncultivated tracts of ground, generally overgrown with furze, broom, heath, and other small shrubs, as Rumblesmoor in Yorkshire, and Blackstone-edge, partly in Yorkshire and partly in Lancashire.

2. A Fell is a large open portion of land, generally less over-run with shrubs than a moor, as Gateshead Fell in the county of Durham.

3. A Heath is an open ground, abounding with the plant called heath or any other shrubs, as Hounslow Heath in Middlesex.

4. Wolds are high open grounds, as the Wolds in Yorkshire and Lincolnshire.

5. Downs are fine open pasture grounds, as the Downs in Kent, Sussex, and Surrey.

6. Fens are low wet tracts of ground, as the Fens in Lincolnshire.

7. Marshes are low swampy grounds, and when adjoining the sea or the sides of rivers, they are mostly excellent pastures; as the Marshes in the counties of Durham and York, contiguous to the river Tees; those in the counties of York and Lincoln, contiguous to the river Humber; and the rich marsh of Romney, in the county of Kent, adjoining the straits of Dover.

8. Mosses are black, turfy, boggy moors, as Ashton Moss, and many others in Lancashire.

9. Forests are wild uncultivated tracts of ground, generally abounding with trees, as Sherwood Forest, in Nottinghamshire, and the New Forest, and that of East Bere, in Hampshire.

10. Ings are large open meadows, generally situated on low, level grounds. Fields and tracts of land known by the local name of "The Ings," abound in almost every county of England.

11. Holmes are hilly, fenny, or level grounds, adjoining to, or encompassed by rivulets or brooks. Many rich and fertile pasture grounds in this country are known under the local appellation of "the Holmes."

12. Open fields are unenclosed lands, generally divided into furlongs by mere forms, and occupied by different tenants.

Some furlongs are usually in corn, some in meadow, and others in pasture; and the cattle and sheep which depasture are tended by shepherds. Large tracts of land upon the Wolds in Yorkshire are cultivated in this manner.

13. A Furlong of land is used in some old books to express the eighth part of an acre; hence 20 perches, or 605 square yards, make a furlong.

The term is also used to denote any number of lands adjoining each other in open fields, and running in the same direction from one head-land to another, and known by some particular name, in order to distinguish the different parts of the field from each other.

14. Mereforms are narrow pieces of swarth, dividing lands or furrows in open fields from each other.

15. An Ox-gang or *Ax-gate* of land is usually taken for 15 acres, being as much land as it is supposed one ox can plough in a year.

In Scotland 13 acres are denominated an Ox-gang, and in some places the term is used to denote as much land as will summer one ox.

This word is corruptly called *Oskan* in Lincolnshire and some other counties.

16. A Hide of land, sometimes met with in old books, was such a quantity as might be cultivated, in the compass of a year, with one plough, having meadow and pasture sufficient to feed the cattle belonging thereto. The term was also frequently used to denote as much land as would maintain a family.

Some writers make the hide to contain 60, some 80, some 100, and others 120 acres.

Sir William Dugdale, the antiquarian, says, that a Barony, in former ages, was a certain portion of land held immediately of the king, and contained not less than 40 hides, or 3840 acres—a statement that gives 96 acres to a hide.

*Directions for setting out new roads, sand-pits, quarries, watering-places, &c., and for dividing commons and waste lands into allotments.*

1. Before commons and waste lands are divided and allotted, new roads must be set out upon them, in the most convenient and advantageous manner. They should, whenever it is practicable, be set out in such directions as to form right angles, or as nearly right angles as possible, at the places where they meet or intersect each other, or come in contact with ancient highways. They should not be less than thirty feet in breadth, and set out in right lines; because straight roads not only look better than crooked ones, but also occupy less ground.

2. All old roads leading over commons or waste lands about to be inclosed, may be stopped or diverted at the discretion of the commissioners; and such old roads must be surveyed and allotted as part of the common or waste lands.

3. Certain portions of commons should always be set out for sand or gravel pits, and for quarries, if the commons contain either sand, gravel, or stone. The portions of ground thus set out are considered



as public property, from which every person who receives a common-right may take materials for building houses, making fences, and repairing roads.

4. If there be any good springs of water on commons, they must either be left uninclosed for the public watering-places, or the water must be conveyed to more convenient situations, by means of drains or channels, and troughs or reservoirs made for its reception.

5. In some places the lord of the manor claims one-twelfth, in some one-sixteenth, in others only one-twentieth, of all commons and waste lands; whatever be his claim, however, it must be set out before any other allotment, after its value has been ascertained from the quantity and value of the whole common. Besides this allotment, the lord of the manor will, of course, be entitled to his proportional share of the remainder of the waste lands, in the same manner as any other proprietor.

6. When it can be done, it is very desirable to ascertain the value of any other claim, and to set out, for the proprietor of the same, an allotment of equivalent value; thus will the whole place become free, and the occupiers of lands be exempt from what they may generally deem an unpleasant tax upon their industry, but which may, nevertheless, be as justly due to the claimants as the rent of a farm is to the landlord.

7. If the clerk's salary arise from the lands, which is the case in some places, a common-right may also be set out in lieu of it; and if another can be obtained as a small endowment for a town's school, the inhabitants will not have cause to repent, if they be judicious in the choice of a master.

8. After the roads, sand-pits, quarries, watering-places, manorial rights, &c., have been set out, the remainder of the common or waste lands must be equitably divided (quantity, quality, and situation of place being regarded), among the owners and proprietors of messuages, cottages, lands, tenements, and hereditaments situated in the township or place where the inclosure is to be made and executed.

**NOTE.**—The first step towards inclosing wet, marshy grounds, is to have them well drained, for without this be done, every attempt at improvement will be vain.

*To determine the value of each proprietor's allotment, or claim upon the common.*

In doing this the value only can be used; for, if we make use of the quantity, in allotting land of different qualities, the proprietor

who has his allotment in land of the best quality will obviously receive more than his just right, while those whose allotments fall in land of inferior quality lose part of their property. Hence, you must say, as the value of the whole estates, is to the value of the common, or land to be divided, so is the value of each person's estate to the value of his allotment, or claim upon the common.

*To set off, upon the plan, each proprietor's allotment or share of the common.*

When you find that a proprietor's allotment falls in that part of the common which is of uniform quality, you may easily determine the quantity to which he is entitled, by saying, as the value put upon the number in which his allotment falls, is to 1 acre, so is the value of his claim to the quantity of land which his allotment must contain. Then set off the allotment upon the plan by some of the methods already described.

But it commonly happens that a proprietor's allotment falls in different numbers. In such a case you must draw a guess-line or lines, and measure separately, by the scale, the pieces cut off belonging to the different numbers: then multiply the different quantities by their respective values; and if the sum of the products be equal to the value of the claim in question, the guess-line or lines are right; if not, they must be altered, until they part off the exact portion. After each proprietor's allotment is set off upon the plan, if you find the quantity and value of all the allotments equal to the quantity and value of the whole common, the division is right.

*Example.*

Lay down a plan from the engraven field-book belonging to Plate XII. and divide the common among the three proprietors, A, B, and C, according to the different qualities of their estates and of the common.

NOTE 1. The learner should lay down the plan, from the field-notes, by a scale of two chains to an inch, and find the areas of all the fields from his own dimensions, as directed in Part V. The diagonals and perpendiculars from which the above areas were found, are not given, as this would have rendered the work too easy to exercise the genius of the student; he may, however, retain his own dimensions, and enter them in "a Book of Dimensions, Castings, Quantities, Qualities, and Values, adapted to Plate XII." (See page 187).

*A Book of Quantities, Qualities, Values, &c.*

## Belonging to PLATE XII.

No. on the Plan.	A's Estate		
	Quantity	Quality	Value Shil. Dec.
	A. Dec.		
1	7-565	<i>xs</i>	378-250
2	7-609	<i>xo</i>	304-360
3	7-301	<i>xh</i>	277-438
Total	22-475		960-048
	B's Estate		
4	7-858	<i>xg</i>	290-746
5	7-892	<i>xc</i>	260-436
6	8-223	<i>xo</i>	328-920
Total	23-973		880-102
	C's Estate		
7	7-819	<i>xh</i>	297-122
8	7-078	<i>xso</i>	424-680
9	7-481	<i>xs</i>	374-050
Total	22-378		1095-852
	The value of the } whole Estates }		2936-002
	The Common		
10	10-061	<i>x</i>	301-830
11	4-680	<i>xd</i>	159-120
12	4-446	<i>xh</i>	168-948
13	5-995	<i>sh</i>	167-860
Total	25-182		797-758

2. If the learner should not be able to find such dimensions as will make his areas agree exactly with those given in the foregoing book of quantities, it will be a matter of no consequence, provided the difference be not too considerable; and as any difference in the areas will also produce a difference in the values, all the numbers in his book will differ from the given numbers. This, however, will tend much to his improvement, as he will be under the necessity of making all his own calculations, both in finding the areas and values of the different fields, and also in dividing the common and proving the division.

The operation of finding the value of each proprietor's share of the common; and directions for setting out the allotments in the field.

$$\text{As } 2936 : 797.758 :: \left\{ \begin{array}{l} 960.048 \\ 880.102 \\ 1095.852 \end{array} \right\} : \left\{ \begin{array}{l} 260.860 \\ 239.137 \\ 297.761 \end{array} \right\} \begin{array}{l} \text{A's} \\ \text{B's} \\ \text{C's} \end{array} \text{ value}$$

797.758 proof.

PLATE XII.

A PLAN from the ENGRAVEN FIELD BOOK.

North.

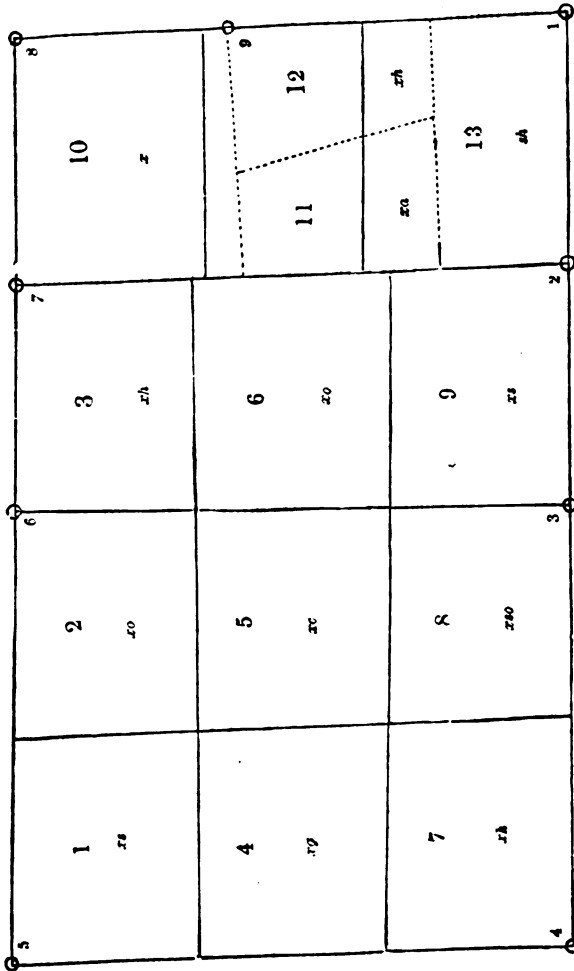

Scale 8 chains to an inch.

As the whole of A's allotment will fall in No. 10, say, as 30 : 1 :: 260·860 : 8·695 acres, the quantity of land which A's allotment must contain.

From 10·061 take 8·695, and we have 1·366, the remainder of No. 10, in value = 40·980, which will form part of B's allotment. Then, from 239·137 take 40·980, and there remains 198·157; consequently, B must have land equivalent to this value from Nos. 11 and 12.

The remainder of these Nos. and the whole of No. 13 will be C's allotment, which you must measure, &c., as a proof.

In setting off the allotments upon the plan we find that one end of the division-fence between the allotments of A and B falls at the distance of 827 links from + 8 toward + 1, and the other end at the same distance from + 7 toward + 2. We find, likewise, that one end of the division-fence between the allotments of B and C fall at the distance of 1465 links from + 8 toward + 1, and the other end at the distance of 1478 links from + 7 toward + 2. Measure, therefore, these distances in the field, stake out the division-fences, and the work will be completed.

NOTE.—The fences of old inclosures are generally very crooked; but the fences of new inclosures are always set out in straight lines, when it is practicable.

#### THE PROOF OF THE DIVISION.

No. on the Plan	A's Allotment			
	Quantity A. Dec.	Quantity A. R. P.	Quality	Value Shil. Dec.
Part of 10	8·695	8 2 31	<i>x</i>	260·850
	B's Allotment			
Part of 10	1·366	. . .	<i>x</i>	40·980
„ 11	2·580	. . .	<i>xd</i>	87·720
„ 12	2·910	. . .	<i>xh</i>	110·580
Total	6·856	6 3 16		239·280
	C's Allotment			
Part of 11	2·100	. . .	<i>xd</i>	71·400
„ 12	1·536	. . .	<i>xh</i>	58·368
Whole of 13	5·995	. . .	<i>sh</i>	167·860
Total	9·631	9 2 52		297·628
Sum total	25·182	25 0 29		797·758

GENERAL DIRECTIONS FOR APPORTIONING LAND  
INTERSECTED BY A RAILWAY.

On referring to Plate XIII. at the end of the work, it will be seen how railways, by intersecting fields, necessitate new lines of fences. Thus, in the parishes of Westbrook and Winston, there is not a single field through which the line passes but what requires to be altered, either by land being added to or taken from it.

Estates, parishes, and counties are severed in a similar way to farms, lands being taken from one that require to be added to another before they can be used in the most profitable manner; while the railway itself has become an intervening estate, containing a large area of land, now in the occupation of a new proprietary.

In a survey of this kind the present and future value of the land is that which principally engrosses the surveyor's attention. In other words, the survey is more a work of valuation than measurement, and as directions for the latter have already been given, those now offered will chiefly refer to the former.

The valuation of severed lands may, for the sake of practical instruction, be illustrated under two examples. First, intersected parks and farms; second, intersected estates, parishes, and counties.

## EXAMPLE I.

*Intersected Parks and Farms.*

In this example we shall suppose the railway to pass through a large estate, severing the game-preserves and other lands in the natural possession of their proprietor, and also those held on lease by tenants, cutting off portions from fields in the occupation of one farmer so small, or detached, as to render it necessary to add them to fields on the opposite side of the line belonging to other tenants. It may also be assumed that the severed lands are farmed under different systems of husbandry, some being under permanent meadow, others under aration.

As a general rule, it may be given that railways will ultimately determine the direction of fences and the form of fields, just as roads, rivers, and boundaries of estates have hitherto done, similarly to what is exemplified in the parishes of Westbrook and Winston, as illustrated Plate XIII.

The doctrine thus taught obviously involves the resubdivision of land on both sides of the railway as the most profitable practice. To this rule there are but few exceptions. It implies that if the

lands are allowed to remain as they are, in a severed state, a permanent loss will be sustained ; but, as in the parallel example of a road, present losses will be more than compensated by future gains, provided a proper subdivision is effected ; consequently, as the proper subdivision of the land may be presumed to be the object of the survey, the two alternatives call for special consideration at its commencement.

1. If lands intersected by a railway are allowed to remain in a severed state, or if they are improperly laid out into fields, their value per acre for agricultural purposes will be permanently decreased.

2. If lands intersected by a railway are properly laid out into rectangular fields of the required size, their value per acre will be permanently increased.

3. Capital invested according to the first rule will not return interest. The investment is a dead loss, and ought, therefore, to be borne exclusively by the landlord, because the tenant, on his part, under such circumstances, has annually to bear an increase of expense and decrease of profit, as a permanent loss per acre.

4. Capital invested in accordance with the second rule will return interest, and if the investment is judiciously made, the amount of interest realised will, in the vast majority of cases, be highly remunerating to the landlord, while the improvements effected ought at the same time to afford equal encouragement to tenant's capital.

The agricultural losses sustained under the first rule may be accounted for by reference to Plate XIII. Thus, if we suppose, what is too commonly the practice, that the triangular portion of field No. 5, lying between the railway and the open drain in the parish of Westbrook, is added to field No. 6, by the removal of the fence that is cut by the line, and that the triangular portion of No. 6, lying between the railway and the road, is added to No. 5, then, under such data, a permanent loss per acre will be sustained of a twofold character, apart from the dead loss borne in removing old fences and making new ones ; and also apart from the greater area of land under fences.

The twofold loss thus sustained is occasioned by an increase of expense and a decrease of produce, as formerly stated, the first arising from working acute-angled and shapeless fields, which will be greater under steam-culture than it has hitherto been under horse-culture ; and the second from the greater length of headlands.

Another source of loss arises from roads crossing the line, as in the case of the farm-road leading up to Hill Farm, which is raised eleven inches ; but in many instances the inclination amounts to

several feet, so that in hay and corn harvest two horses are required to do what formerly was done with one, while a boy has to attend to the gates at these two busy and expensive periods of labour.

Permanent losses of this kind are first experienced by tenants, but ultimately by landowners. In the case of the home-farm the latter bears the whole loss.

There are other losses which have to be valued that are not of a permanent character, and which, therefore, may have to be solely borne by the tenants whose lands are severed. Thus, an inferior quality of soil, in a high state of fertility by artificial means, taken from a tenant at the commencement of his lease, may be worth more annually for a short term to his neighbour who gets it than a better quality of land in an exhausted state from mismanagement received in exchange. Instances might be quoted where differences amount to more than the rent of the land during the remainder of a lease; and with the progress of science and an increasing amount of capital invested in farming, such differences are of greater importance than they were formerly.

For agricultural purposes a rectangle is the most profitable form of a field. This may be given as an established *formula*—that which is practically embodied in the second and fourth rules above.

Any deviation from the rectangle, occasioned by the inclination of the land or other cause, will be attended with a corresponding permanent loss; and the amount of this loss will be greater under steam-culture, as now performed by a wire rope, than it has hitherto been under horses. In other words, the best system of cultivation is that for which provision should be made by the surveyor.

As the railway determines one boundary fence, the direction of the parallel and perpendicular fences may also be considered as ultimately fixed. Thus, the two *limit of deviation* lines may be taken to represent the first two parallels, one on either side of the railway, as shown in Plate XIII.

In the case of the park, woods, game-preserves, pleasure-grounds, and home-farm, in the natural possession of their owner, present losses are generally greater, and future profits more distant, owing to the larger amount of ornamental work destroyed by the railway, and the corresponding increase of capital required for new improvements of this description. But, granting this, a railway may be made far less objectionable in a park than a common road, while in very many parks and demesnes it may be the *base-line* of much needed improvements, alike for ornament, pleasure, game, and profit.



When an old plan of the estate is furnished, as is generally the case, a copy of the plan may be taken by tracing-paper, and the railway laid down upon it. This will enable the surveyor to determine the *new design*, and apportion the grounds.

In a work of this kind every case must be its own rule. When the line crosses a river, road, or valley, at a distance from the mansion, it may have to be left open for ornament, but generally it will require to be covered. This may be done by planting forest timber, ornamental trees, and shrubbery favourable to game, to compensate for other grounds taken into the home-farm to square off arable fields. In the case of permanent meadows and other grass lands, if angles and straight lines are avoided, the more shapeless the areas are the better, provided the outlines are natural. Although game require retirement, yet pure air, light and sunshine, with natural food, are essentially necessary to health and the fine normal flavour of their flesh, and if these are secured for them, they will soon become familiar to the most noisy traffic on the line, and even prefer it to the interior of close, dark, and unhealthy forests and game-preserves.

Lands thus laid out for timber and game-preserves on both sides of a railway should communicate with each other by bridges under or over the line, as shown in the section Plate XIII. at No. 1 and No. 2; and where a choice exists, the latter, generally speaking, will give more satisfaction than the former. When a railway crosses a river, a brook, or even a drain, a footpath on one side will form a very inviting communication between game-preserves.

#### EXAMPLE II.

##### *Intersected Estates, Parishes, and Counties.*

A railway may be considered a permanent landed estate, in the possession of a separate and distinct proprietary, and, therefore, a suitable boundary between farms, estates, parishes, and counties.

The practical rule involved in this can be profitably carried out in all cases where a railway intervenes between farms, estates, parishes, and counties, in such a manner that the land taken from one can be equitably given in exchange for what has been cut off from another, the work of apportioning being made in accordance with the old familiar maxim of "take and give," as shown in Prob. XI. and XII., Part V.

It may also be profitably carried out in cases where the small differences of value between portions of severed land can be settled,

either by money or by an exchange of land in some other place. Thus, A may receive from C land to compensate for what B has received from A, while C may receive from B what will balance the triune account.

Exchanges of this kind enhance the value of land in several ways. It does so to railway companies and the public as follows. Thus, if timely notice were given the former that the lands intersected by their line would be exchanged, and that their estate would be made a permanent boundary, they would often be enabled to obviate bridges under and over the line, and crossings on a level with the rails; consequently, capital would be economised in its formation, and expenses in working it afterwards, while in the outset they could afford to give a higher price for the land. The safety of the public, again, would be better cared for, more especially at the crossings to fields and farms on a level with the rails, cattle being very liable to get upon the line at such places, gates to be left open, and things to be dropped from carts and left upon the rails.

In exchanges between landowners of portions of their estates present and future values require to be considered under the following three heads:—1. The agricultural value of the land; 2. The mineral resources of the land; 3. The adaptation of land for building purposes, and others of a kindred character.

1. In examples of land exclusively adapted for agricultural purposes *to present values must be added facilities for future improvement.* Thus, according to the old adage, "Lay clay on sand and you buy land." If, therefore, an estate possesses within itself facilities for improvement by the mixing of soils, and which may not have existed prior to the formation of the railway, the materials having to be conveyed along the line or part of them, such must be carefully taken into account. On the other hand, some sandy, clayey, or mossy lands may be worth more to another estate than to the one to which they belong, because the former possesses such facilities while the latter does not.

2. Railways have considerably affected the mineral value of land. Generally an advance has been realised, but there are examples to the contrary, so that every individual case must furnish its own rule for valuation.

3. In the immediate vicinity of towns, or railway stations, or places on the line where a new railway station might advantageously be made, lands adapted for building purposes always form a prominent topic in a survey accompanied with a valuation and plan of exchange.

When the growth of the population of a place is rapid under the prospect of a continued state of prosperity, lands for building may increase in value.

Again, when a town is overcrowded by narrow streets and antiquated houses, there is every prospect of suburban lands increasing in value, if the trade of the place is flourishing.

The extension of railway accommodation is also thinning out many of our large towns, and as the inhabitants are being spread over a larger area, market-gardens, nursery-grounds, dairies, and various manufactories are being removed farther inland. In all such cases there is an increasing demand for land a short distance from town, with a corresponding increase of value.

Rectangular areas of land are of more value for building purposes than triangular and shapeless pieces. This is of growing importance to landowners and tenants for long terms, more so than it was some time past. The increase of value is partly owing to the architectural reformation that old streets and buildings are now undergoing; but principally to the general progress of science demanding a greater economy of time and labour. Thus, when a street crosses another at right angles, the traffic in the one has only to wait until that of the other moves across the breadth of the street in which the stoppage takes place. But when streets cross each other diagonally the crossings increase in length, so that the expense of time and labour may be twice and even thrice that of the rectangular system. And this, too, is not the worst feature of diagonal crossings, for horses cannot turn round the acute angles without stopping both the up and down traffic, while in turning at obtuse angles the opposite error is experienced, viz., too great a velocity, and tear and wear of streets and vehicles. To these practical objections must be added other three, viz., the greater area of land consumed both by streets and houses; the increase of expense in their formation and annual repair; and the reduction in the accommodation which they afford for business; and when the student sums up the objections on both sides, he will then be able to appreciate the difference between the rectangular and diagonal systems of laying off land for building purposes, and how much two proprietors of building lands would gain by exchanging triangular and shapeless pieces of land situated on opposite sides of a railway, so as to enable each to square off his property, and thus give it the highest value.

## SECTION III.

GENERAL DIRECTIONS FOR TAKING SURVEYS OF RIVERS, CANALS,  
EMBANKMENTS, AND LANDS RECLAIMED FROM THE SEA.

The directions in this section will be given under the following six examples, viz. :—

EXAMPLE I.—Directions for the survey of lands to be reclaimed from the sea.

EXAMPLE II.—Directions for the survey of a tidal river.

EXAMPLE III.—Directions for the horizontal survey of lands reclaimed under Ex. I. and II.

EXAMPLE IV.—Directions for the survey of a river in a large valley from high water level upwards.

EXAMPLE V.—Directions for the survey of mountain rivers.

EXAMPLE VI.—Directions for the survey of canals, irrigation-works, and warp-lands.

## EXAMPLE I.

DIRECTIONS FOR THE SURVEY OF LANDS TO BE RECLAIMED FROM  
THE SEA.

Before land is reclaimed from the estuary of a tidal river on one or both banks, by means of embankments, a survey of it is usually made. The object of the survey is to enable the owner or owners to ascertain the area that can be recovered, the dimensions of the embankments required, and whether the land, when reclaimed, will return sufficient interest to justify the investment of capital necessary to complete the work, and lay out the land for agricultural purposes.

Such a survey necessarily includes a plan and section of the embankments and mouth of the river. The land to be reclaimed may be presumed to extend to both sides, but as the two areas are similar in character, directions for one will be sufficient.

The embankments are thus what are usually termed *the sea embankments*, in contradistinction from those of the next example that extend inland along both sides of the tidal part of the river.

Parallel examples are to be found at most of our large rivers, such as those that flow into the Wash, from which large areas of fen land have been reclaimed and added to the counties of Lincoln, Huntingdon, and Cambridge. Holland presents examples of still greater magnitude. In this country, in our colonies, and other parts of the world, a vast amount of land may yet be profitably reclaimed.

In some places surveys are easily taken both for plan and section. Thus, where the land is only under water at spring tides, it will be covered with herbage, so that a complete survey, horizontal and vertical, may be taken at first, as no difficulty stands in the way of determining the position of the embankments, fences, watercourses, roads, buildings, &c., required in laying out the land reclaimed for agricultural purposes. In others the work embraces an indefinite amount of sectional detail, owing to the nature of the subsoil, and the difficulty of determining the position and magnitude of the embankments. The latter will be the most instructive example to adopt. The more advisable course in examples where the position of the embankment cannot be determined at once, is to include two areas of land by means of two boundary lines, the one area greater than will probably be reclaimed, and the other less.

The boundary line of the largest area may be termed the *maximum-extreme*, or the exterior line, or outer line; and the boundary line of the lesser area the *minimum-extreme*, or the *interior line*, or *inner line*.

A preliminary horizontal survey for the plan will thus be necessary. It will embrace the details of the area between the outer and inner boundary lines, but only a general outline of the lands inside and outside.

The survey for the sections should precede that for the plan, as the position of the two boundary lines cannot be determined until the former work is concluded. This arises from the treacherous nature of the subsoil, which, in the vast majority of cases, cannot be judged as to quality from mere superficial appearances. The boundary lines have consequently to be carefully examined before the several stations are finally fixed upon for the maximum and minimum extremes between which the position of the embankment is presumed to run. In doing so, to avoid, if possible, going over the line a second time, the distances of the ground line below the surface level of the sea at high water should be taken and entered into the field-book, which will form part of the details of the sectional survey.

#### *Directions for ranging station-poles.*

The first station-poles that require to be set are those at the mouth of the river, two on each side, one for each boundary-line.

The outfall or mouth of the river is often the most difficult point in the survey to determine. In some cases, for example, it is more advisable to make a new outfall than to continue the old one; consequently this is the first point that requires to be settled, and the following general rules may be given for that purpose:—

1. When the channel of the river at low water contracts at its mouth, when the subsoil is of such a quality as to permit of an embankment being easily thrown across this narrow place from one side to the other, and when the old bed of the river above this expands into basins, it may then be advisable to change the outfall.

2. When the land to be reclaimed extends to a great distance on each side of the river, and when an embankment can be thrown across the channel, the river may be divided, and its waters discharged into the sea by two outfalls, one on each side. This may be done partly to intercept the water from tributary streams and drains, and partly to throw it into the sea at a higher level.

3. It may be advisable to change the outfall in order to economise capital invested in the formation of the embankment.

4. The outfall may be changed to afford increased facilities for inland navigation.

5. The outfall may be changed to facilitate the accumulation of mud, and the formation of new lands for subsequent reclamation from the ocean.

Having fixed upon the place for the station-poles at the mouth of the river, which we shall suppose is not to be changed, two on each side, a transverse section of the channel and embankments between them should be taken and entered into the field-book. The ranging of the other station-poles of the survey may then be proceeded with, at the different angles or points of the two boundary lines, together with those of the seaward and landward stations.

If the ground cannot be conveniently driven with a chain, which is often the case, the poles should be ranged purposely for the *three areas* of land, being ascertained by trigonometry; the first comprising all included by the survey beyond the outer boundary line; the second that within the inner line; and the third area, the land lying between the two boundary lines.

One reason for ranging two boundary lines, is to furnish the necessary data for obtaining an estimate of any line which may be determined upon between them for the embankment. So far as the work of the surveyor is concerned, no more difficulty is experienced in giving a section of the embankment at the exterior boundary than at the interior one. In point of fact the two lines are two sections, either of which may be adopted, or any third line between them. But were only one longitudinal section of the embankment given, it might be otherwise with those who have to carry out into practice the proposition of reclaiming the land from

the ocean. But when they have the alternative left of turning to the right hand or left, between two extremes sufficiently far apart to meet all the exigencies of the case, the practical solution of the problem as to the position of the embankment can then be determined satisfactorily.

When the boundary lines are covered with a sufficient depth of water to float a flat-bottomed boat or coble, the station-poles may often be more conveniently ranged by such means, during the flow and ebb of the tide, than at low water. And when thus ranged the levels of both boundary lines may be taken at high water by the same means, and the ground, longitudinally and transversely, between them also examined, by boring into the subsoil under the water over the edge of the boat. Between the seaward and landward stations the surveying staff can thus employ their time without interruption until the station-poles are ranged, the lines examined, and the levels are taken.

The station-poles in the two boundary lines are ranged purposely to obtain the levels of the transverse and longitudinal sections, as well as the boundary lines themselves, and care should be taken that the line of the intended embankment lies between them, so that when it is made, the exterior line shall fall without, upon the sea side, and the interior one shall fall within, upon the opposite or land side.

The area between the boundary lines should be carefully examined, so as to determine if a sound foundation for the embankment exists between them.

The station-poles in each boundary line should be numbered, and the two lines distinguished from each other by different letters of the alphabet, and this requires to be done both upon the plan and sections. Thus, the station-poles of the exterior line may be numbered *1a*, *2a*, *3a*, &c., and those of the interior line *1b*, *2b*, *3b*, &c. And as the survey commences at the mouth of the river, it will be more convenient for the consecutive numbers to run from that point, the two stations on each side; there being *1a* and *1b* on the left bank, and *1c*, *1d* on the right bank.

The number of station-poles in each boundary line require to be equal, and the corresponding numbers should be opposite each other. Thus *1a* should be opposite *1b*, *5a* opposite *5b*, and so on for the other numbers in each line.

The object of this order is to get the data for the transverse sections. Thus between *1a* and *1b* there is a vertical plane that must be surveyed and shown upon the plan by a section, the ground line being represented by the bottom line, and the surface or high-

water level at the top of the station-poles being shown by the upper line.

The number of transverse sections will depend upon the nature of the ground. If the surface is a regular plane, one for each straight line will be sufficient, but if undulating, one may be required for every concave and convex part.

The transverse section has a twofold purpose to serve. *First*, It shows the slope or angle of depression seawards which is required both for the embankment and the drainage of the land. *Second*, The levels being thus given at the two extremes (the outer and inner boundary lines), and shown upon the transverse section, the height of the surface level at high water above any point in the ground line between them can be easily ascertained from the scale upon which it is drawn.

Two longitudinal sections are required, one for each boundary line. They show the top and bottom levels at each station-pole along both lines, and the numbers and letters of the alphabet that distinguish them from each other should be carefully attended to, so as to obviate error in copying from the working plan and section.

The levels are taken at high water by placing a mark upon the station-poles at the highest point to which the tide rises for the surface level, and by measuring its distance from the ground to obtain the bottom level; and the marks thus placed upon the station-poles should be carefully examined a second time at high water, in order to ascertain if the levels are correctly taken, before the base line is ranged and the theodolite placed for taking the bearings. This is usually termed "checking the levels." It should be done between flow and ebb, when the weather is calm and the surface of the water "smooth" and free from ripple, and when right they will all lie in one plane.

#### *Directions for the Horizontal Survey.*

As the horizontal plane intersects the vertical ones at the several pairs of station-poles, the points of intersection and lines which they form are consequently common to both surveys. In all cases, therefore, when the vertical lines cannot be measured with the chain, this part of the vertical survey may be profitably supplied from data taken under the horizontal survey. Such, according to hypothesis, is the case in the present example.

The base line should range parallel to the general direction of the boundary lines, or as nearly so as practicable. Level ground and easily gone over should be chosen, in order to secure the greatest accuracy in measuring with the chain. This is necessary, as the true



length of the lines between the station-poles in the two boundary lines will depend upon that of the base line. In the field the significant practical rule, *the best of three*, is generally given, *i.e.*, measure the base line three times and take the average.

The bearings are taken as in ordinary surveys with the theodolite, and directions for such will be found in Sect. VI. Part IX. and p. 385.

The stations and lines which they form should be shown upon the plan, as represented in the plan of the Preliminary Survey for a projected Railway, Part X. Sect. I. And the two boundary lines may be represented in a similar way to what the two lines indicating the *Limits of Deviation* of the Parliamentary Survey are in Plate XIII.

If the surveyor undertakes to lay down a line representing the centre of the embankment, it may be determined as in Sect. I. Part X., and shown between the exterior and interior boundary lines upon the plan, as the line of railway is represented in Plate XIII. between the two lines indicating the *Limits of Deviation*.<sup>1</sup>

The object of thus showing the working details of the survey, both horizontal and vertical, is to enable engineers, contractors, or their draughtsmen to take off working plans more readily for the execution of the work of embanking, &c., and for this purpose doubles of the plans and sections are generally ordered when surveys are extensive.

Where several landowners are interested they may order an approximate estimate of their respective shares of the land to be reclaimed, which can easily be taken and shown upon the plan, by rules previously given in the work. But the final work of apportioning shares should be left to a more complete survey when the embankments are finished, and when the lands recovered from the sea and the river can be laid out into fields, and the lines accurately measured with the chain. (See Ex. III.)

The position of sluices, syphons, or pumping stations, and existing embankments, require to be taken and shown upon the plan, and also the position of watercourses necessary for the drainage of adjoining lands that lie above the level of the top of the embankments.

The general rule for the latter is, that no water should be allowed to descend from a higher level into the watercourses of the lands to be reclaimed that can otherwise be drained off to the sea or river.

*Directions for Longitudinal and Transverse Sections for Embankments.*

When the survey includes longitudinal and transverse sections of the embankment, it is more accurately and easily done to show them upon a separate plan by themselves, than to crowd them into the preliminary one, along with those previously given.

This part of the survey includes the ground from whence materials are to be obtained for the formation of the embankment; and the quantity of materials will depend upon the dimensions of the embankment, quality of soil, and exposure to the sea.

The exceptions are few where the foundation of an embankment can be safely laid upon the surface of the ground to be reclaimed. Even in those cases where it has to be run through a shallow arm of the sea, according to the plan pursued in many cases in Holland, and also in this country, a proper foundation should afterwards be dug out inside of sufficient breadth to contain a body of clay that will prevent the water outside from finding its way by any porous strata to the interior, and thus ultimately endangering the safety of the whole area of land reclaimed.

As a general rule, sea embankments should be formed of inorganic materials, as clay or clayey gravel, and the nearest ground containing such, if at command, is generally that included in the survey. With the means of railway conveyance now at command, contractors enjoy many facilities for getting an ample supply of such materials that were not within the reach of their predecessors, so that if the surveyor finds a choice, the best quality may be preferable, although situated at a greater distance.

The principal reasons why vegetable and other organic matter should be excluded from the interior of embankments are as follows :—

1. All organic matter of the kind in question is subject to decomposition. If, therefore, an embankment, or any portion of it extending from the outside to the inside, is formed of materials that contain a large percentage by bulk of such, this percentage may in the course of time be dissipated in the atmosphere, and the inorganic portion reduced to an open porous body approaching in character as if formed of pure sand or gravel, through which the sea-water will ooze, and eventually flow.

2. Embankments which contain a large percentage of vegetable matter are liable to destruction from vermin of a very multifarious and indefinable character, as rats, moles, mice, worms, and innumerable kinds of insects, some of which are so small as to be invisible

to the naked eye. This motley brood live upon each other and the decaying vegetable matter as their normal food: the organic portion of the embankment is thus literally consumed, while the inorganic part that remains is so burrowed as to resemble in some measure a sponge, through which the sea water will ooze, eventually effecting a breach, as in the previous case.

3. A third reason may consist of a combination of the first and second, and in practice this is perhaps what is generally experienced, the depredation of insects and other animals, together with the action of their excreta and putrefying remains, hastening the chemical changes that destroy the stability of the embankment.

When old embankments that have to remain are included in the survey, they should be carefully examined in order to have destructive causes of the above kinds, and the extent of injury done, faithfully delineated. For this purpose a good microscope is essentially necessary; and if it is discovered that the embankment is giving way, it may be advisable to recommend the employment of men to whose professional labours these branches of science belong. The amount or area of damage done will, however, require to be examined by the surveyor, and shown upon the plan and section of the old embankment.

## EXAMPLE II.

### DIRECTIONS FOR THE SURVEY OF A TIDAL RIVER.

The present survey may be presumed to contemplate improvements extending from the mouth of a tidal river upwards to the highest point where the tide flows. The field operations lie between Examples I. and IV., and are chiefly sectional in character, embracing longitudinal and transverse sections of the channel and its embankments.

Many of the directions given in the last example relative to the ranging of the station poles, the taking of levels at high water, and the survey of the horizontal and vertical planes for the preliminary plan and sections, are applicable to the present, and therefore need not be repeated.

The chief points requiring notice are as follows:—*First*, the breadth of the river as determined by its tributaries. *Second*, the breadth of the river as determined by tidal action. *Third*, the velocity of the river as determined by its tidal length. *Fourth*, new channel and embankments. *Fifth*, methods for counteracting tidal action. *Sixth*, influx of tributary rivers.

1. *The breadth of a river as determined by its tributaries.*

The increase required in the breadth of a river to contain the waters of tributary streams, so as to maintain its velocity at low water and prevent damming back above the point of junction, is directly as the volumes of water which the tributaries discharge.

If, for example, a tributary river discharges a volume of water equal to that flowing in the tidal river, then the breadth of channel required by the latter below the point of junction will be double that above where the two rivers unite. Or the breadth of the united rivers, as it requires to be shown upon the plan and transverse section, is equal to the sum of the breadths of the two rivers before their junction, their velocities and volumes of water being equal.

Had the tidal river contained twice the volume of water it received from its tributary, then the increase of breadth required would have been one-third; and for any other increase of volume, greater or less, a corresponding increase in the breadth of the channel at low water is necessary, to preserve the natural velocity of the tidal river below the point of junction, and to prevent the damming back process above this point (allowing no increase of breadth for friction, which must always be determined on the spot).

In applying the above data either to the laying out of a new channel for the tidal part of a river, or in straightening or effecting any improvement of the old one, it must be borne in mind that an increase in the depth will not compensate for breadth. The rule is founded upon an established law that cannot be violated without consequential losses being sustained, for a greater velocity effected by an increased altitude of the surface-level of the water, involves the damming back process above the point where this superelevation of the surface-water takes place; and when the increase of depth is effected by digging a deeper channel, the practice is abortive, amounting to a standing pool below the natural inclination of the bed of the river, so that no increase of velocity is obtained to convey the extra volume of water received from the tributary.

2. *The breadth of a river as determined by tidal action.*

The action of a tidal river upon the sides or slopes of its channel and embankments, and also upon its bottom, is directly as its depth, the quality of the ground being equal or uniform.

This rule is based upon the established data at sea, viz., the deeper the ocean the higher the waves and the greater the force with which they strike the vessel or lash the shore, and the heavier the amount of damage done during a storm.

On a sandy, gravelly, clayey, or muddy sea-shore, the counteracting force of the return water down the inclined slope formed by the flowing and ebbing tide is a safer defence to the slope than the more solid materials of its structure.

Under differences of geological strata the coarser the quality of the gravel or sand, the more obtuse is the angle of the slope of the sea-beach, and *vice versâ*.

The same practical data will be found exemplified in beds of rivers that have been scooped out by the natural action of the water.

The above data may be seen instructively illustrated on a sea-beach during a storm, or channel of a river during heavy floods; and both examples should be examined on shores of different qualities of soil, to obtain the invaluable information they afford.

The length of the transverse section representing the breadth of a tidal river at its mouth will therefore be as the height of the high-water level line above the ground line or bottom of the channel; but inversely as the angle of depression which the ground line makes with the horizon or high-water level.

As the extra depth of the river above its mouth produced by tidal action gradually decreases until it ceases to exist, it consequently follows that the extra breadth required for tidal action will also decrease in a corresponding manner, and finally cease to exist at the point where the tide ceases to flow.

This gradual decrease of breadth requires to be carefully ascertained in the survey and delineated upon the plan, and also shown by the transverse sections of the river, at its mouth and at the junctions of the tributary streams and upper end of the survey where tidal action terminates.

The general doctrines taught in the preceding directions have reference to the uniform retarded and accelerated velocity of the river during the flow and ebb of the tide, so essentially necessary to the safety of its channel and embankments. Thus during the flow of the tide the velocity of the river will be retarded, and the direction of the current at its mouth and upwards gradually reversed, owing to the damming back process that takes place by the rising of the surface-level of the ocean above that of the water in the river. But when the ebb commences the river will again begin to flow to the ocean with an accelerated velocity. Now, if the above rules have been properly carried out, then the retarding and accelerating processes will be so uniform as hardly to be perceptible to the eye of the observer, the downward current of the river being gradually counteracted by the upward flow of the tide, while the

elevated surface of the dammed-back water will during the ebb as gradually fall to the low-water level.

If, however, the river is confined between high embankments at its mouth, and if the channel upwards is of unequal breadth, being narrow in some places, and spread out into basins of great width in others, so as to form inland seas or lakes during high water, then "races" (as they are sometimes termed on old plans and in old deeds) will be found in the narrow parts between them. The force of the stream in such places is not easily calculated, or embankments defended from the impetuosity of the current during spring-tides, when a more than ordinary rapid fall of the ocean in front is attended by a heavy inland flood behind, or *vice versâ*, when an extra high tide is accompanied with a low level of the river, so that there is little or no counterbalancing action to the upward current, by the damming process of the downward one.

### 3. *The velocity of the river as determined by its tidal length.*

The velocity of a tidal river at low water is inversely as the length of the tidal part; or, the shorter the distance between the mouth of a tidal river and the highest point to which the tide reaches, the greater the velocity of the river at low water; and, *vice versâ*, the greater the distance the less the velocity.

By straightening a meandering tidal river its velocity at low water will be increased, because its course will be shortened.

The practical data upon which the above two rules are founded may be given thus. If we assume the difference of the depth of the river at its mouth between low water and high water to be 12 feet, then this is the fall of the whole tidal portion of the river included in the survey. If we next assume that the length of the tidal part is twelve miles, that the ground is of equal quality and the inclination uniform throughout its length, it will give a fall of one foot per mile. But if the length is twenty-four miles, and the other conditions the same, then the fall per mile will only be six inches; consequently the velocity in the latter example will only be that due to six inches, or one half the former.

The formation of bars in the beds of rivers is produced by a decrease of velocity, the sand and gravel being deposited when the force of the current is so reduced as not to be sufficient to carry them farther. Bars across the mouths of rivers are formed in the same way, or jointly by the action of the sea.

The extra depth of the tidal part of a river which gradually increases towards the sea, when the bottom soil is of uniform quality, is produced, partly by the accelerated velocity of the water during

the ebbing of the tide; partly by the scooping-out process of opposing currents during the flow of the tide; and partly by the action of the waves towards the sea in stormy weather.

If the ground forming the bed of the river is not composed of materials of uniform quality, the inclination of the bottom will not be uniform throughout its length.

Bars formed in the bed of the river require to be shown both by longitudinal and transverse sections; inequalities in the bottom, produced by different gradients, only in the former, unless special circumstances call for a transverse representation. Bars beyond the mouth of the river seawards are usually shown upon the plan, the depth of water over them being represented by figures. All bars, both at sea and in the channel of the river, if dry at low water, require to be surveyed and shown upon the plan as dry land; where rock crops out in the bottom, it should be indicated both on plan and section, and also any special diversity of soil, as a change from clay to sand.

#### 4. *New channel and embankments.*

A new channel for a river may be occasioned either by changing its outfall, or straightening the course of the old one, and both (it may be presumed) are included in the survey.

##### *A new outfall.*

In surveying ground for a new outfall, the inclination of the bottom of the sea and the quality of the ground require, in the vast majority of cases, to be carefully examined for a considerable distance out seawards, before the depth and breadth of the mouth of the new channel can be determined, according to the directions given under the second head of this example. The exposure of the new outfall also requires to be attended to; for if the one side of the channel is more exposed than the other, a greater slope must be given both to it and the embankment, so as to make the return action of the water down the inclined plane defend it, as formerly shown, during a heavy storm.

In a few exceptional cases the new outfall may be made over a rocky bottom at various levels between high and low water, in which the breadth of the river from its mouth upwards will be determined accordingly. Thus, if the new channel is made to intercept the water from the elevated grounds on one side of the low lands, and to discharge itself over a rocky bottom on a level with high water, then the new river will cease to be a tidal one and to be subject to tidal action; consequently its breadth will be determined by its

inclination and volume of fresh water, as in the next example. If, however, the rock is on a level with low water, then the breadth of the river will depend upon the nature of the ground forming the sides of the channel, and upon the exposure of its mouth to the waves of the sea during storms; and for intermediate levels the rock will defend the channel from tidal action according to its height, tidal action being inversely as the height of the rocky bottom above low water level.

*Straightening a river.*

In the language of practice, straightening a river more frequently means reducing the number of curves and right lines than the formation of one straight channel.

In every survey, therefore, the direction of a new channel for a river has to be determined on the spot.

If the object of a new channel is to effect a more efficient state of drainage, then the nearer its direction approaches a right line, the shorter will be the whole length of its course, and the greater the fall gained at low water for any given distance.

By such means the length of the tidal portion of some rivers in the United Kingdom may be reduced to one half—of others to one third, and of one or two exceptions to one fourth of their present length. In such cases the increase of fall gained, and also the area of land reclaimed from the river, may be easily calculated.

The directions for the capacity of the straight portion of a new channel are the same as those given for the survey of the longitudinal and transverse sections of the old.

If a new channel is to be opened between two bends of the old so as to cut off one intervening bend, the best line of direction will be that of tangents to the two curves.

In straightening a river according to this rule the radius of any curve may be easily increased, so as to change the angularity of the current when it strikes the concave bank at too acute an angle. This may be done, for example, by extending the tangential direction of the new channel outwards, the required distance from both the old bends, so that the two station poles at the two extremities of the straight portion of the new channel shall be in the two curves at the two points where the two radii touch the new line of channel, so as to form with it right angles.

In the field this is done by going backwards until the whole of the curve on one hand and new channel on the other shall appear on the river side of the station poles; and the centre of the circle at each curve is the point where two lines ranging from station poles



at the two extremities of the curve intersect each other, the one line forming a right angle with the new channel, upwards or downwards as the case may be, and the other a right angle with the direction of the old channel, downwards or upwards as the case may be.

The less the radius of any curve, the less must be the inclination of the slope of the channel and embankment on the concave side, to defend it from the current, and, *vice versá*, on the opposite or convex side to maintain the capacity of the river required by tidal action.

A transverse section of a curve of a river is thus different from that of the straight portion of the channel.

#### 5. *Methods for counteracting tidal action.*

One method for obviating the destructive action of tides in tidal rivers has already been given, viz., by changing the outfall to a rocky bottom.

A second method is by a tide-lock, or several tide-locks, if the volume of water is large. Such may be constructed either at the mouth of the river, or in the first narrow place above it, if preferable.

A third method may consist of a tide-lock for shipping at some distant point communicating with the river by means of a canal, the channel of the river itself being defended by a series of waterfalls from the high to the low water level, constructed on the principle of a salmon ladder, and which might serve that purpose.

A fourth method consists of floodgates or sluices, in number according to the size of the river, across its mouth or some more convenient place above it.

These several methods are now in operation, and hence call for surveys.

The details of the practice are similar to those of canal-surveying, and will be given under Example VI.

#### 6. *Influx of tributary rivers.*

The survey of a tidal river generally includes that of its tributaries to a distance as far up from their mouths as contemplated improvements extend.

Where lands have been reclaimed, or are proposed to be so, at the mouth of a tidal river, as in the example, the first two tributaries surveyed are those that previously discharged, or now discharge, the drainage waters of the more elevated grounds through the un-reclaimed land into the sea, which require to be diverted from their

old channels and turned into the river by two new courses—one on each side the main stream.

Where old embankments exist at the inland boundary of the newly-reclaimed land, they may probably be turned to profitable account by forming one of the embankments of the first tributary, if the upland drainage-water cannot be intercepted at a higher level.

In those cases where no land has previously been reclaimed, and where embankments do not exist, the high-water levels of spring-tides often determine the course of the two first tributaries for intercepting the drainage-water of the elevated grounds, and discharging it into the main river by opposite channels.

These are questions that always require to be determined on the spot by taking the levels of high water at the necessary station poles, and the other station-levels on more elevated ground. They are seldom surrounded with much practical difficulty; and, as the formation of the two first intercepting tributaries form the initiatory work of the contractor in the reclaiming of the lands lying between them and the ocean, this division of the survey should be the first finished, as the plans or copies of them may be demanded before the others.

The waters of a tributary and main river should unite with equal velocities, so as not to form bars across either channel, or in any way way disturb the uniform flow of the principal stream.

Where a tidal river runs through a narrow valley, tributaries very frequently enter at too great a velocity; but such can easily be reduced by means of a waterfall, or series of waterfalls, as in the case of mountain streams in Example V.

The longitudinal and transverse sections of tributary rivers are similar to those of the principal, so that the directions given relative to the latter are applicable to the former.

### EXAMPLE III.

#### GENERAL DIRECTIONS FOR THE HORIZONTAL SURVEY OF LANDS RECLAIMED UNDER THE FIRST AND SECOND EXAMPLES.

When a large area of land has been recovered from the sea and a tidal river by embankments, it requires to be surveyed and laid out into fields and farms for agricultural purposes. And if it belongs to different proprietors, as is frequently, if not generally, the case, when the reclaimed lands extend to both sides of the river, the whole will have to be apportioned according to the several proprietary rights involved.

In its general character the survey resembles that of a common proposed to be apportioned under the Inclosure Act, for which directions have already been given ; but in the following details it differs in many respects—viz., 1. Quality of soil ; 2. Drainage ; 3. Embankments ; 4. Roads, fences, and farm-buildings ; and 5. Area outside embankments.

### 1. *Quality of soil.*

The agricultural value of the land cannot be separately investigated from its proprietorship. This arises from the difficulty of distinguishing at times between different qualities of soil, especially that reclaimed from the sea, before it has yielded crops of any kind, so as to afford practical evidence of its productive value per acre ; consequently, surveys of this kind, when marches are not well defined, often call for the highest degree of professional talent to make the most of the land, and to do justice to the landowners and tenants interested. On the other hand, when the line of subdivision between properties is well defined, and when the land is of uniform quality, the problems of apportioning and laying it out into farms and fields are of easy solution.

### 2. *Drainage.*

In laying off the principal drains for the drainage of the land they should, as far as practicable, form boundary lines between estates and farms. They are usually divided into main and tributary. The former are the largest ; they carry the waters of the latter directly to the sluices or pumping-stations at the embankments ; and the latter, sometimes designated cross-drains from their position, discharge the water they collect from the fields and farm ditches into the former. When the land is comparatively level, the water in the small ditches between the headlands of fields very frequently flow to both sides from the middle—a difference in the depth being all the fall that can be given them. In such cases the *watershed* should be shown upon the plan. In other cases the water-shed may be at one side, or between two fields—the water drained from the one field running to the right, and that from the other flowing to the left. In other cases, again, the field ditches are cut to a more uniform depth for the purpose of bottom irrigation, as shown under Example VI.

Straight lines and rectangular fields form the rule, one that also applies to main drains, estates, and farms. The tributary drains, however, where they enter the main drain, should have a gentle curve in the direction of the main current, so as the waters of

the former shall not retard the velocity of those of the latter in times of flood, or silt up the channel when the stream is low, and its force reduced to a minimum.

The laying off of the main and tributary drains necessarily involves a large amount of levelling, which is now done with instruments, either spirit-levels or draining-levels; and, as the inclination is often less than 1 in 5000, the work requires to be carefully performed, otherwise flood-water will prove its inaccuracy.

### 3. *Embankments.*

The lines for the main drains and other subdivisions having been determined, and station poles ranged for measuring them with the chain, the ranging of station poles along the top of the embankments from one extremity of the survey to the other, may be proceeded with as the next step in field operations. The base-line of the previous survey with the theodolite may be continued; but if the lines along the embankments form a series of right lines of considerable length, with but few curves to break their angular connexion, it may be advisable to adopt one of them for a base-line—or the whole series for a series of base-lines—as right lines along the top of embankments can always be driven with greater accuracy than those across broken and uneven ground. The true position or range of the right lines on both sides of a curve can be easily determined by special check-lines and the other bearings of the survey.

The preliminary survey was made exclusively with the theodolite, the measuring of the base-line with the chain excepted; the present is taken both with the chain and theodolite, the distance between the station poles now placed upon the top of the embankment, as well as at the base, being carefully measured with the chain, as also the length and angle of the slopes and total breadth of the base: all deviations from the former dimensions or position of the embankment made during its formation require to be measured, as also the inside drains running parallel to it, and junction of the main drains therewith. The true position of sluices, pumping stations, &c., require to be shown.

The directions for taking the bearings in this survey are similar to those given in the preceding, and also those for laying down the true position of the embankments and river upon the plan.

The lines and offsets to subdivisions, &c., are measured with the chain and offset-staff, and the measurements entered in the field-book as in ordinary surveys.

#### 4. *Roads, Farms, and Farm-buildings.*

Public roads, and private ones leading from them to farm homesteads, require to be between fences, but farm roads from the homestead to the fields may run alongside fences, being only fenced on one side.

In laying off land for public roads in a level district of newly-reclaimed fen or marsh land, the two chief points for consideration are as follow :—*First*, that without increasing their length they shall serve as much as possible the private purposes of the individual farms through which they pass ; *Second*, that they shall form the shortest or the nearest and most direct route to church, markets, railway-stations, &c.

Sometimes the direction of roads and fences is determined by dry grounds rising above the general level of lands recovered from the sea and tidal rivers, and offering inviting sites for farm-buildings. As such are in many cases invaluable they may not only determine the ground for the homestead, and the direction of roads and fences, but also the size of farms ; consequently such are preliminary questions that ought to be settled with landowners and tenants before boundary and subdivision lines are finally determined.

Live fences have sometimes an open ditch on each side, in other cases only a ditch on one side, while in a few exceptional examples as yet the lands are thoroughly drained and cultivated close up to the bottom of the hedges, the hedgerows being regularly hoed and kept as clean and free from weeds as drilled green crops of beans. Such, therefore, are also preliminary topics that, like the above, should be determined before the lines are finally ranged for being driven with the chain, more especially if the plan is to be drawn to a large scale, and everything shown in a highly-finished style.

The directions for laying off ground for farm-buildings, including labourers' cottages, water for the same, and for stock in the fields, are similar to those given in a subsequent place, Part VII.

Lands reclaimed from the river are generally added to the adjoining farms, the fences running directly to the river. This may give rise to alterations in the cross-fences, and the rule for determining the position of both subdivisions will be the size of the farm and fields in every individual example.

#### 5. *Area outside Embankments.*

The extent of the survey outside the embankments will depend much upon whether land is accumulating, or the contrary. If new deposit is being formed at every tide, landowners have an

interest in ascertaining the direction of this new formation, in order to watch its progress and preserve the rights which they or their posterity may possess to reclaim it from the sea at some future period. A survey, therefore, may be presumed to determine the proprietary rights of those who employ the surveyor. It may extend to a considerable distance beyond what dry land appears above low water, and the depths of ground under low water level are taking by soundings, and shown upon the plan in their proper places. Where the nature of the ground will not permit of station poles being set, as is frequently the case, buoys require to be anchored for taking the bearings. Buoys may thus be in deep water and station poles on dry ground, and the bearings are taken partly with the theodolite from the top of the embankments, or any other land station, and partly with the compass—a mariner's compass being preferable in a boat at sea to the pocket one of the land-surveyor or the compass of the theodolite. The position of the buoys at sea, and land-stations from which the bearings of the former are taken, should be shown upon the plan, so as to enable landowners at any time to take the depth of the sea at low water at any desired point, in order to ascertain whether deposit was making progress or not.

#### EXAMPLE IV.

##### GENERAL DIRECTIONS FOR THE SURVEY OF A RIVER IN A LARGE VALLEY FROM HIGH-WATER LEVEL UPWARDS.

The survey under this example is presumed to contemplate improvements in straightening and embanking a large river immediately above high-water level, either in terms of 24 & 25 Vict. c. 133, or by the mutual agreement of the proprietors interested. It may be presumed either to commence at that point of the river where Example II. terminated, and to end where the next example begins, or to commence at the ocean. Field operations will comprise horizontal data, as shown upon the plan, and vertical data, as represented by longitudinal and transverse sections. But as rules for the former have already been given, the directions will chiefly apply to the latter, the vertical survey under the following eight heads:—1. Outfall levels of the river and its tributaries; 2. General fall of the river; 3. Volume of water; 4. Area of land required for embankments; 5. Subdivision and apportioning of land where the river is straightened; 6. Water power, irrigation works, bleaching grounds, &c.; 7. Provision for the drainage of adjoining lands;

8. New roads, bridges, fences, and drainage, filling and levelling of the old channel.

1. *Outfall levels of the river and its tributaries.*

The beds of rivers at high water outfalls may frequently be lowered so as to drain more efficiently at low water the lands lying on both banks upwards. The outfall-level is, therefore, the first that has to be surveyed.

There are four methods by which the surface level of the outfall of a river may be lowered ; viz., *first*, by widening the channel ; *second*, by deepening the channel ; *third*, by straightening the channel ; and *fourth*, by increasing the velocity of the current.

FIRST METHOD.

Rivers gradually increase in breadth from their sources to their mouths, according to the influx of their tributaries, the width being thus inversely as the depth at any section.

The natural breadth of a river is, by the above rule, determined by its tributaries and the quality of the soil of which the bed is formed ; consequently, if the natural breadth of the outfall is doubled, the depth will be reduced one half, and the surface level thereby lowered in the same ratio (making no allowance in breadth for extra friction). Thus, if the present depth is 6 feet and the width 300, then by increasing the width to 600 feet, the surface level of the outfall will be lowered three feet for drainage, the velocity in both cases being the same.

In practice, the rule will be found generally to apply thus : the river at the outfall, or towards this point, will be found to be narrowed by various obstructions, thereby damming back the water and raising its surface level ; consequently, if such obstructions are removed, it follows that the river will be widened, and its surface level lowered.

The narrowing causes that require special notice are rock ; the central piers of bridges ; tide-locks and sluices ; rocky channels ; quays and harbourage for shipping ; boats and barges moored or plying in the river ; trees deposited ; piles driven in for fencing and other purposes.

When obstructions of the above kind can be removed the increase of breadth gained requires to be shown upon the plan ; and the same data applied to the outfalls of tributaries.

SECOND METHOD.

When the present breadth of the outfall is sufficient, but the

bottom of the channel so elevated by rocks, bars, or the like, that it can be lowered, such would lower the surface level at low water, and thus improve the drainage during a large period of the ebb and flow of the tide. This would allow the tide to flow farther up the river, thereby subjecting it to tidal action, for which provision will require to be made as previously directed (Example II.), but if half the period of the ebb and flow can be gained for drainage, the advantage may do more than compensate for all expenses.

The formation of new bars across the outfall, in examples where old ones have been removed, can be prevented by reducing the current of the river to a uniform velocity. Thus, the cause of the deposit of sand and gravel being a greater velocity and force of current at some part in the river above the outfall than at the outfall itself, it follows that if the river is deepened at that part, and widened, if necessary, so as to bring the bottom and sides of the channel to a uniform inclination, then the formation of a new bar could not take place; for the velocity and force of the current at the latter section would be equal to its velocity and force at the former section; consequently, no depositing materials would exist to be thrown down, the scooping out and depositing causes being both obviated.

The details of the survey under this method lie chiefly on the vertical plane in the longitudinal direction of the river, but two transverse sections will be required, one at the outfall, and the other at that part of the river above proposed to be deepened.

#### THIRD METHOD.

The increase of fall gained by straightening a river has already been shown in Example II. Thus, if by straightening a river its length can be reduced to one half, the fall per mile will be doubled, and the surface level lowered by such means directly as the velocity is increased. Hence the gain for drainage.

In practice, the rule may be carried out in two ways. *First*, by straightening the river and removing the outfall farther down the tidal channel, which would improve the drainage at low water. *Second*, the old tidal bed may be preserved, and two tributaries, one on each side, taken farther down by two straight channels to improve the drainage. An extra fall of several feet may frequently be gained by such means. Under the second way the surface level of the outfall in the old bed will be lowered directly as the amount of tributary water removed.

Under this method the details of the survey are chiefly on the horizontal plane.



## FOURTH METHOD.

It is manifest that if the velocity of a river at its outfall can be doubled, the depth will be reduced one half, and the surface level lowered in the same ratio, as the quantity of water discharged in both cases would be equal in equal times.

In practice, the rule is seldom applicable to examples of the kind under survey unless where stagnation of the water in the river takes place at the outfall, not from narrowing cases, as in the *first method*, but from the reverse, too great a breadth, the object of the survey being to obtain the necessary sectional data for confining the river within a proper breadth of channel at its outfall, and thus obtain a sufficient velocity to prevent deposit of every kind.

This extra breadth of outfall may be effected by one of two causes either by a rapid above having a sufficient force to scoop out a broad pool at the outfall, and thus form a bar on the other side; partly by the joint action of the tide; or else by too small a velocity, the growth of reed, and accumulation of muddy deposit. Both examples are more frequently met with when the outfall is at the sea, than when it is far inland at the point where the ordinary tide ceases to flow.

In the case of a rapid above the outfall and a bar below, the rule is to deepen the channel at both places, so as to bring the bottom to a uniform inclination, as under the second method, and to reduce the width of the outfall section to its proper dimensions.

In the case of a deposit of mud the narrowing of the channel at the outfall, and the confining of the river in its proper rectilinear direction, will increase the velocity, clear out the bed and lower the surface level of the outfall at low water; but if the growth of reed has been allowed to commence, and the plants to take deep root, they may require to be cut: but the execution of works of this kind do not belong to the survey: at the same time, the surveyor may be called upon to report as to their magnitude and how they are to be done.

In both these examples the details of the survey are similar to those of the second method.

The above methods of lowering the surface level of the outfall of the principal river are applicable to the outfall levels of its tributaries; but when the general inclination of the bed of the former is altered, that will also affect the outfall levels of the latter.

## 2. *General fall of the river.*

The position and level of the outfall section having been taken

the next branch of field operations is to find the whole fall of the river between the lower and upper ends of the survey, in order to determine its general inclination, and how much additional depth can be gained for drainage and water-power purposes. Technically the operation is termed *levelling*, an illustrated description of which will be found in Sect. I. Part X. as applicable to railway surveying. The work is done by instruments of various kinds, but as levels thus taken are subject to errors that require to be corrected, it is usual in river surveying to check them by *water levels*, all our large valleys affording ample opportunity for taking "check levels" of this kind. In this and in several other respects, the survey differs widely from that of a railway.

The errors that require to be corrected are three in number: *first*, tangential errors; *second*, errors due to refraction; and *third*, hypotenusal errors.

#### *Tangential Errors.*

There are three errors of this kind that require notice. *First*, deviation from the arc as to curvature, or errors in curvature; *second*, deviation from the arc as to length, or errors in length; and *third*, deviation from the horizontal level, or errors in the practice of taking the horizontal levels.

*First.* If BE, in the annexed diagram, represents an arc of  $60^\circ$ , then AB is radius, BD tangent or the horizontal level, and AD secant. In the direction of the secant AD the extent of deviation is ED, which in this case is equal to radius; but if a perpendicular is dropped from BD to E, parallel to AB, the extent of error will then be equal to the versed sine, or half the radius AB, when the arc is  $60^\circ$ . The former is the extent of error usually adopted, viz. the difference between the radius and the secant of the arc; so that, taking the diameter of the earth at 7912 miles, the correction for  $60^\circ$  would be 3956 miles, *i.e.* the semi-diameter.

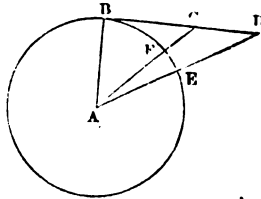

If we suppose the length of the tangent one mile, then, according to Theor. VII. Part I., ED is equal to  $\sqrt{(AB^2 + BD^2)} - AB$ ; the extent of error would, therefore, be  $\sqrt{(3956^2 + 1^2)} - 3956 = \cdot 000128$  of a mile, or 8 inches. For two miles  $\sqrt{(3956^2 + 2^2)} - 3956 = \cdot 000505$  of a mile or 32.028 inches.

*Second.* The next error consists in taking the length of the tangent for the length of the arc, or rather a rough guess for it, as the line measured in practice makes an angle of elevation with (BD) the

horizontal level. Thus in the diagram if  $BF$  is an arc of  $45^\circ$ , then  $BC$  is tangent and equal to radius or 3956 miles; whereas  $BF$  is only 3107.04 miles, according to data subsequently given under Example VI. The error in length for  $45^\circ$  is, therefore, 848.9 miles. For  $60^\circ$  the tangent  $BD$  is 6301.6 miles; the arc  $BE$  4142.7 miles, giving 2158.8 miles as the tangential error in length.

*Third.* There are two methods of taking horizontal levels, the one with a backsight from the station, at which the level is placed to the levelling staff; and the other with a backsight and a foresight to two levelling staves. The former practice may be termed the single tangent method, and the latter the double tangent method.

The single tangent method of taking levels is the correct one. It is subject to the two preceding tangential errors, and also to those arising from refraction and measurement with the chain. As the dead levels of canals will furnish a more instructive illustration of the practice than the surface levels of a river, it will be illustrated under Example VI. But general directions will be given under the longitudinal section of this example.

The double tangent method of levelling, although it has received the sanction of long use as being sufficiently correct for general purposes, is nevertheless erroneous; consequently the single tangent method has to be adopted when a greater degree of accuracy is required, or when obstructions prevent the level from being placed half-way between the two levelling staves. An illustrated description of the practice will be given under Railway Surveying, Sect. I. Part X., as it is better adapted for roads and railways than for surveys of rivers, canals, waterworks, and the like. It will, however, be advisable in this section to point out to the student the errors that attend the double tangent method of levelling.

The double tangent method is based on assumptions contrary to fact and geometrical rule, as the following three examples will show.

Ex. 1. The practice in the case of an acclivity or a declivity assumes that the two secants of the two arcs are equal, while it proves the contrary, the readings from the two levelling staves indicating a difference. Thus, as the two levelling staves represent two "normals," or portions of two radii, it follows that when they indicate a difference, as they always do on an inclined plane, the two radii, with their respective arcs, tangents, and secants, are also different, which is the contrary of the assumption that they are equal.

Ex. 2. If an exceptional position of the level and levelling staves is assumed, viz., that the readings from the latter are equal, thereby proving the two tangents, secants, radii, and arcs equal, as when the ground is a horizontal level, or when the level is placed on

the top of a hill, and the two levelling staves on the two declivities downwards—or when it is placed in the bottom of a concave surface or valley, and the two levelling staves on the two opposite acclivities upwards—then another assumption (which will be pointed out under the next example), that the back-secant is different from the fore-secant, and that the two thereby correct for curvature, is contrary to the previous one that they are equal.

Ex. 3. The practice assumes that the level is equidistant from the two levelling staves between which it is placed; (see diag. Sect. I. Part X.), that the latter represent two secants; the former a common radius; the two lines of sight two tangents; and that as the two tangential deviations are the one *minus* and the other *plus*, they, therefore, correct each other. Now these assumptions, passing over the errors already pointed out, can only, under the most favourable circumstances of the case, be received as very distant approximations, obtained contrary to geometrical rule, for the half-way position of the level cannot be determined until the whole distance is measured with the chain, until the horizontal levels are taken, and the true lengths of the two arcs and two tangents ascertained, which cannot be done by the practice itself. Hence the reason why surveyors are obliged to adopt the other method.

#### *Errors due to refraction.*

Directions for correcting errors arising from refraction on the horizontal plane will be found in Sect. I. Part X.

On the vertical plane the correction for refraction is different. Thus, when the telescope is levelled in a horizontal direction, the amount of refraction is 33'; but when elevated to 45° it is only 1', or more correctly 57", being three seconds less than the thirty-third part of what it is at the horizon; while directed to the zenith it is *nil*, a star or bird passing over the field of the telescope appearing then in its true position.

#### *Hypotenusal Errors.*

Errors of this kind arise from the undulating and uneven surface of the ground, which requires very great skill in driving the chain to take the distances between the level and levelling staff with that degree of accuracy which the nature of the survey demands. In horizontal surveying the correctness of the length of the lines measured with the chain is tested both by tie lines and the trigonometrical data obtained from the bearings taken with the theodolite; but in a vertical survey there are fewer opportunities of testing the geometrical truthfulness of the work.

The line measured with the chain in the vertical plane is the hypotenuse of a right-angled triangle, represented by  $ci$  in the diagram to Example VI., the triangle there being  $ixc$ , and the errors that require to be corrected are the deviations from that line. In practice the rule is to place the level and levelling staff in the same hypotenusal plane. This frequently gives rise to short backsight distances at one operation, when the greatest degree of accuracy is ordered. And when a concave or convex surface intervenes between the level and levelling staff, a second levelling staff, and a third if required, is, or are, placed between upon the highest and lowest grounds; the object of the intervening levelling staves being to take the offsets from the line of collimation or sight, so as to determine the curvature of the surface (the line measured), and the true length of the hypotenusal line sought. (Station poles will answer for intermediate staves.) If, in measuring the hypotenuse on the horizontal plane the leader was to place his arrows sometimes a few feet on one side of the line, and sometimes a few feet on the other, the driver would be aware that the measurement thus found would exceed the true length of the hypotenuse sought, just as the two sides of a parallelogram do that of the diagonal. And the same practical rule applies to similar deviations from the hypotenuse on the vertical plane.

#### *Check-water levels.*

In valleys check-water levels can frequently be taken by the water levels of canals and mills; or they may be taken by damming back the water in side drains, or even in the river itself under survey. Examples of this latter kind might be quoted where the dead level for several miles was ascertained in less time than it could otherwise have been. Thus, a dam was made in the evening, and next morning stakes were driven in to the water's edge, which finished the work. In extensive surveys, where the investment of large capitals is involved, check-water levelling should never be lost sight of when at command; more especially if the inclination of the river is small, and consequently every inch of fall gained for drainage invaluable.

#### *Longitudinal section.*

In comparatively level valleys the inclination of rivers is frequently so nearly uniform that a longitudinal section is not ordered, transverse sections at particular parts being considered sufficient. In other cases longitudinal sections may be required for those parts of the river that are straightened; but when extensive

improvements throughout the survey are contemplated, a section of the whole length may be necessary.

If we suppose that the diagram, Prob. V. Part IV., represents a portion of a river that is proposed to be straightened by a new rectilinear channel; that  $a$  and  $x$  are two stations in the survey; and that the new channel is to be on the same side of these two stations as the old one, it will give the student an illustration of an example of the latter kind requiring a longitudinal section for the whole length.

The horizontal survey may be taken as there directed; a plan drawn according to the dimensions given in the field-book; the course of the new channel represented by two straight parallel lines, and the severed lands apportioned.

Under such conditions the dimensions sought are the lengths of the old and new channels, the fall between station  $x$  and station  $a$ , and the surface levels of the old river, when such are necessary.

If  $+a$  is visible from  $+x$ , or if  $+x$  and  $+a$  are seen from a third station beyond  $+n$ , so as to form two straight lines  $xn$  and  $na$ , then the line  $ax$  sought may be found as follows:—

Measure  $an$  and  $nx$  with the chain, and take the included angle with the theodolite, which will give  $ax$  by Case II. Part VIII.

If  $+a$  is visible from  $+x$ , the angle of depression would give the angles of the right-angled vertical triangle of which  $ax$  is hypotenuse, so that the fall may be got by trigonometry, the correction for curvature being the radius of the earth at  $x$  minus the versed sine of the arc between that radius and the radius of the earth at  $a$ , similar to what is shown in the diagram, Example VI., the corresponding right-angled triangle there being  $icx$ , and the correction  $ix - xz = zi$ , the fall between  $i$  and  $c$ . Or it may be got by various formulæ given under Example VI.

If the levelling staff when placed at  $+a$  is sufficiently high to reach the line of collimation or horizontal level at  $+x$ , the fall will thus be determined at once, the correction for curvature being now secant minus radius.

But if the levelling staff has to be placed at  $+n$  and  $+a$ , or any other number of intermediate stations, then the sum of the falls is the total fall, and the corrections for curvature and refraction have to be made at each fall, and not for the sum as a whole.

In a similar manner if three intermediate station-poles are ranged in a line between  $+a$  and  $+x$ , one in  $cm$ , the second in  $mr$ , and the third in the line opposite, it will intersect these three lines (which belong to the horizontal survey) so as to form four triangles.

In each of these two sides and the included angle are determined by the horizontal survey, all the given angles being proved by tie lines. The four remaining sides or distances can therefore be got by trigonometry, when their sum will give the total distance  $ax$ .

The length and fall of the new channel thus found will give its inclination, and also the fall of the old one, but not the length and inclination of the latter.

The length of the old channel is determined by the horizontal survey. It should be carefully measured with the chain, and will be found in the above example nearly one third of its length longer than the new one; *i.e.*, the length of the new channel is only two thirds that of the old one, so that there is a gain on the fall of one mile in three for improved drainage.

*Surface levels of the river.*

If the velocity of the river is uniform, its length and fall will give its inclination; or if its inclination is uniform, its fall and length will determine its velocity. But such conditions are never realised in a meandering river, the bends invariably proving the flow to be both accelerated and retarded; for a decrease of velocity at a bend involves an increase above, while as rivers descend toward their outfalls, their general velocities decrease. Hence the practice of taking the surface levels of the stream in order to determine how far it deviates from the hypotenusal plane of its inclination.

Although the course of the river is crooked, its longitudinal section may be represented as straight. Thus in the annexed diagram if  $AB$  is the length of the old channel,  $ED$  the length of the new one, and  $BC$  or  $FE$  the fall without correction for curvature, then the triangles  $ABC$  and  $EBC$  will be two right-angled triangles similar to *cix* in the diagram Example VI. The two normals in

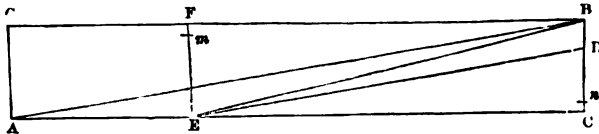

the two cases are  $BC$  and  $FE$  in the above, and  $ix$  and  $yc$  in that of Ex. VI. The hypotenusal plane of the old channel is  $AB$ , and that of the new one  $EB$ .

The correction for curvature is generally so small as with difficulty to be represented on the section. At the same time it must not be overlooked in plotting the dimensions, for reasons subsequently given.

If  $BC$  is found by trigonometry, then  $EC$  is the sine of the lesser

arc of which  $E_r$  (not shown) is radius,  $r$  being the centre of the great circle where the two normals  $BC$  and  $FE$  meet;  $C_n$  is the versed sine of the arc  $E_n$ , and represents the correction for curvature. The fall is thus  $B_n$ ; but if the fall has been taken from the levelling staff  $EF$ , according to a former hypothesis, then the correction for curvature is sec. - rad. or  $FE - Fm = Em = B_n$ , the fall as before.

The correction for curvature on  $AB$  is greater than that on  $EB$ , although both lie between two stations on the survey, because the old channel traverses a curved surface. But the difference is less than it would be were the channel straight. The actual difference is therefore very small in the majority of examples. It requires however, to be attended to, for reasons which will be seen in the next paragraph, and in practice it is generally approximated on what is termed "the safe side."

If it is intended to give the new channel the same inclination as the old one (which is a general rule, the inclination being rather less than greater, so as not to wash away soil), then draw the line  $ED$  a distance below the parallel to  $AB$  through  $E$  equal to the difference between the corrections for curvature of  $AB$  and  $EB$ , which will give the fall  $D_n$  of the new channel, and  $BD$  the fall gained for drainage.

At any place between  $+a$  and  $+z$  the fall for drainage may be got by an intermediate normal at that place or a vertical line nearly parallel to  $BD$  between the two lines  $EB$  and  $ED$ .

The surface levels of the stream may at some places rise above  $AB$ , and at others fall below it. Thus, if no obstructions from piers of bridges, fords, and the like exist, then the surface-water line will be concave, falling below  $AB$ ; but if side and bottom obstructions are numerous, the water-line will be convex, rising above  $AB$ . At acute bends of the river as at  $+6$  (page 136) a damming back process, with an elevated surface and retarded velocity, will be found. This involves a greater velocity at the narrow part above  $+7$ , so that the former level may be above  $AB$  and the latter below it. These require surface level stations, one or two at each bend and narrow place.

#### *Plotting the dimensions.*

As the field operations of the vertical survey commence at station  $z$ , so do the office ones of plotting the dimensions. Thus draw the normal  $BC$  indefinite in the direction of  $C$ ; the tangent  $BF$  indefinite in the direction of  $G$ ; the diagonal  $BE$  according to dimensions found, making with  $BF$  the angle of depression also found, and the sine  $EC$  at an angle equal to  $FBE$ . If the work is thus far correct  $EC$  will cut  $BC$  in  $c$ , making a right angle at  $c$ , and  $BC$  equal to the dimen-



sion found by trigonometry. Next,  $EF$ , taken from the field-book, will cut  $BG$  in  $F$ , making the angle at  $E$  greater than a right angle, and the angle at  $F$  less than a right angle. Produce  $CE$ , in the direction  $EA$  indefinite, and with the measured length of the old channel from  $B$  cut  $CA$  in  $A$ . Draw  $AB$  and  $EB$ ; also  $ED$ , nearly parallel to  $AB$ , as before directed. Mark off the surface level stations  $+1$ ,  $+2$ , &c., on  $BA$ , commencing at  $B$ . The deviation of the water-line from  $BA$  may then be plotted from the readings of the levelling-staff at  $+1$ ,  $+2$ , &c., the operation being similar to plotting a crooked fence on a horizontal survey from offsets taken from a line driven with the chain.

In the preceding example, from the shortness of the distance between  $+x$  and  $+a$  it is assumed that the latter station is seen from the former, and that the height  $EF$  is taken from the levelling staff at one operation: but when the survey extends over ten, twenty, or forty miles, this cannot be done.

In a comparatively level valley, forty miles, and even the length of a degree, or seventy miles, may be included between two normals as  $BC$  and  $FE$ , and two parallels  $BF$  and  $CE$ , the former,  $BF$ , a tangent to the greater radius  $Bm$  and arc  $Bm$ , and the latter,  $CE$ , a sine to the lesser radius  $Er$  and arc  $Er$ .

In this case the distance  $EB$ , between the two extreme stations  $E$  and  $B$ , would be determined from the horizontal survey as before, and so would  $BA$ . But besides  $BE$  and  $BA$ , there would now be a series of diagonals corresponding to the number of intervening levelling-staff stations. In most examples the position of the series of diagonals would be above the common diagonals  $BA$  and  $BE$ ; in many places, however, they may be below, but in all their position and length can be easily determined, and plotted with the section according to constructive geometry, the series of diagonals being similar to the sides of a polygon on the horizontal plane, and the surface levels of the stream may be accurately drawn therefrom.

In more extensive surveys the longitudinal section should be divided into sectors, as in the diagram Example VI., which contains three, purposely drawn to show the principles of plotting.

The vertical offsets with the levelling-staff being taken above the diagonal  $AB$ , and not above the sine  $AC$ , the practice of laying down the surface levels from the latter, or from a datum line below it, is not correct, because  $AG$  is greater than  $BC$ ; consequently the offsets above are greater than those below.

*General rule for the inclination of the channel.*

The angle of depression of the channel of a river should be that which will give to the flowing current a force sufficient to keep it clear of sediment in times of drought, when the surface level of the stream is low, but not such as will wash away its sides and bottom during periods of flood water, when the surface level is high.

If the fall and inclination are less than what is given in the rule, deposit will be formed, and the channel of the river gradually silted up. On the other hand, if it is greater, the force of the stream will wash away first the lighter materials of which the channel is formed, thus undermining the heavier, so that its proper shape will be destroyed, and its course made liable to change at every storm or heavy fall of rain.

In practice it is difficult to make provision for the two extremes, the minimum and maximum volumes of water, as sediment cannot be avoided during low water without injury being sustained in times of heavy floods. Practical rules are sometimes advanced relative to the proper fall per mile that will obviate both objections; but such can never be safely taught, unless upon the spot, and even then with much caution and allowance for differences in the quality of soil; for as such rules are deduced from the actual velocity of other rivers, because they are considered favourable examples, it follows that if there exists the slightest difference between the two soils of which the channels are composed, either silting or washing away will be the inevitable result, as shown in Example II.

When a new channel is proposed, as in the above example, the advisable plan for both the surveyor and drainage engineer is to make ample provision for flood waters, so as to obviate ruinous tear and wear. To effect this, all differences arising from corrections for curvature, refraction, &c., should be thrown upon the proper or safe side, so that the fall and inclination shall be rather less than calculated; and the practical reason for this is, that the small deposit of silt that takes place at low water will be removed during floods if the true form and direction of the channel are preserved.

In the generality of cases the old channel will be the best example as a practical rule for the new one, the soils opposite being for the most part equal, and the lowest velocity of the old river may be taken for the general inclination of the latter.

*3. Volume of water.*

The volume of water during the highest floods is that for which provision has to be made by the survey, and this has to be ascer-

tained by measurement. In the same manner the transverse sectional capacity of a new channel may be determined from that of the old one. A diagram of a semi-transverse section will be given under the next head, Embankments.

#### 4. Area of land required for embankments.

The areas of land required for the two embankments, including the two forelands, have generally to be computed separately from the area occupied by the channel between them and from the two areas outside: the several areas being shown upon the plan.

For the sake of illustration, let the annexed diagram represent a semi-transverse section of the river at station  $x$ , page 136. Then  $x$  will show the land outside at  $+x$ ,  $a$  the top of the embankment,  $b$  the foreland between the embankment and edge of the channel,  $c$  the bottom of the channel,  $Bn$  the depth of the fall (see previous diagram),  $CC'$  the horizontal plane of the sine  $EC$ , and 1, 2, 3, 4, and 5, the vertical offsets.

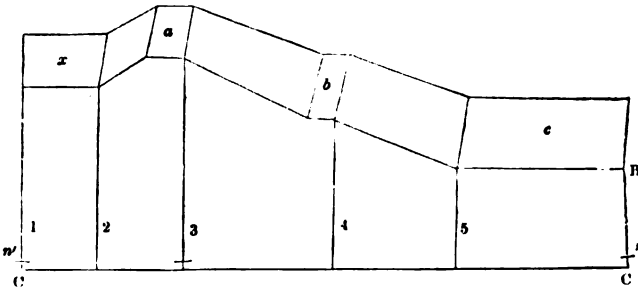

The inside capacity being uniform throughout the bottom  $c$ , the slopes of the channel and embankment, and the level of the foreland, will be similar at other sections; but the offsets will decrease towards  $A$ , and the surface level at  $x$  may be higher or lower.

By improved drainage rain-water is now much faster removed from land than formerly, and a corresponding provision should be made for such, by higher embankments and a greater breadth of foreland between the bottom of the inside slopes and edge of the channel of the river.

The foreland should be parallel to the top of the embankment and surface of the water, and not much above the ordinary level of the latter during the winter season.

The bends or curves of rivers should be of the greatest possible radius, and the slopes on the concave side opposed to the current at bends should be greater, or of a less angle, than where the river is

straight; and the top of the embankment whose concave slope faces the current, should be higher than the opposite convex one.

A greater area of land is required for the embankments and channel at curves than where the river is straight; and the additional breadth, both for the embankments and channel, should, if practicable, be taken from the opposite or convex bank of the river.

5. *Subdivision and apportioning of land where the river is straightened.*

The method of apportioning land on the equitable principle of "take and give" is similar in this example to that described when land is intersected by a railway, Sect. II.

6. *Water power, irrigation works, bleaching grounds, &c.*

If levels are properly attended to, the straightening and deepening of rivers will give an increase of water-power for mills, proportionally to the increase of fall gained, but it will reduce facilities for irrigation, bleaching, and like purposes.

When the bottom of the channel is lowered, water-wheels require to be lowered to the same extent, and also the watercourses.

The two watercourses may also require to be of greater length, especially the one above the mill, in order to draw off the water from a higher level, so as to avoid an intercepting wire across the stream, which is always objectionable.

Such alterations involve a large amount of both field and office work, but, although the greatest degree of accuracy is required in taking the levels, the operation is not generally attended with much difficulty. If the water-power is large and of great value, longitudinal and transverse sections of the mill-courses may be included in the survey, but when it is small, the details may all be shown upon the plan, the fall being indicated by figures.

When water is taken from the river for irrigation, breweries, bleaching, &c., by gravitation, the lowering of the channel will render it necessary to draw off the water from a higher level, which will increase the length of the watercourse. Thus if the channel is lowered one foot, and if the fall per mile is one foot, then the increase of length for the watercourse will be one mile.

7. *Provision for the drainage of adjoining lands.*

All surface and spring water gathered above the level of the top of the embankments is generally discharged into the river between embankments, and what is collected below that level is discharged by sluices and similar contrivances.

As the water from elevated grounds may frequently be discharged into the river between embankments at a much higher level than what is requisite to drain the lower grounds, the side drains for the latter may have to run under the former, and be discharged into the main channel at a point farther down, in order to gain the proper fall.

The levels for such tributaries are generally included in the survey of the principal river ; and when the works are large, sections of them may be required, but when small the vertical details may be shown upon the plan.

8. *New roads, bridges, fences, drainage, and levelling of the old channel.*

If, in straightening a river, the new channel shall cross a road, a new bridge will be required ; and as old bridges are frequently not well situated, the old road may also have to be taken up, and a new one made. For similar reasons old fences will often have to be removed and new ones formed.

A new bridge, in such cases, is generally considered a favourite place for a transverse section ; and if a new road is also required, the prolongation of the transverse level of the roadway on both sides of the new channel will form the surface-level of the longitudinal section of the road.

The foundation of the piers of bridges should be of such a depth as to be defended by a pool in a similar way to what is shown in the next example of mountain streams—the safety-line being considerably above the base-line of the masonry, or top of the piles, where such are used.

The superficial area of the old channel will have to be surveyed, and sometimes its capacity also measured, in order to ascertain the quantity of materials required to fill it up. This latter measurement is usually given in cubic yards. The expense of filling up the old course with the materials excavated from the new one, may likewise have to be estimated before the lands can be valued and apportioned.

When a tributary discharges itself into the river at the part straightened, it may in some cases be allowed to enter the new channel by the old one ; or a new course may have to be surveyed and laid off for it, between its old mouth and the new river.

When the old river, or a portion of it, is to be filled up, the course of the whole, or the part, as the case may be, will have to be shown on the plan by dotted lines ; but where the whole or the part is to be left open, such will require to be represented upon the plan accordingly.

When the old channel is to be filled up, and when a large covered sewer is placed in the bottom of the old channel for the purpose of drainage, its course may have to be represented upon the plan by a dotted line, its mouth where it enters the new channel being shown on the longitudinal section, when such is ordered.

The ranging of the poles for the horizontal survey, the measuring of the lines with the chain, the taking of the bearings with the theodolite, and the other minor details, are similar to what will be found under Prob. V. Part IV., and subsequently Part IX. Section VI.

### EXAMPLE V.

#### GENERAL DIRECTIONS FOR THE SURVEY OF MOUNTAIN RIVERS.

That which chiefly distinguishes the rivers of mountainous districts from those of a comparatively level open country is their greater fall and velocity, and the peculiar phenomena to which such give rise, as the formation of pools, rapids, waterfalls, cascades, &c.

Pools and rapids are occasioned partly by the scooping-out process of the water, and partly by the formation of bars across the river. In all cases where the fall is great, the water, by its continuous scooping-out action, either cuts down to the rock, or sweeps before it, in heavy floods, stones and gravel to a less inclination, where such materials accumulate in a bar, forming a rapid below and a pool above. In this manner bar after bar rises in the channel, until the whole bed of the river, from its source to its confluence with the ocean or large river, in the campaign valley, is formed of an alternating series of pools and rapids, differing in length and depth according to the nature of the ground and force of the current.

In those cases where the water washes away the soil in the natural formation of a channel, and flows upon a rocky bottom, waterfalls and foaming cataracts are formed of various magnitudes.

In other examples rivers flow into and out of lakes, in channels consisting of pools and rapids, or of rocky bottoms.

The pools and rapids formed in gravelly soils are a natural protection to the bed of the river and the adjoining lands on both banks. The water, when it leaves the pool at the top of the rapid, begins to descend with a minimum velocity and force, which gradually increase to a maximum; but the accelerated velocity and force acquired in its descent is lost in the pool below. As the river thus pursues its course it leaves the pools above it at a minimum velocity, but enters those below at a maximum.

The depth and form of the pools at the bottom depend upon the force of the current and the nature of the subsoil. If water is gently decanted into a full vessel, the influx current will only penetrate a short distance into the stagnant fluid below ; but if the decanter is elevated, and the volume and force of the water increased, it will sink to a greater depth. The river as it flows down the gradient forming the rapid into the pool below, is governed by the same hydrostatic law. When small it will penetrate to a short distance below the surface, but when swollen it will sink to a greater depth. If large stones are embedded in the subsoil, they may deflect the current, and thereby prevent the bottom being scooped out to so great a depth as otherwise it would have been. But where bottom soils are equal, the depth of the pool will be directly as the altitude and force of the swollen current during the greatest floods.

The elevation of a bar above the general inclination of the river will, like the depth of a pool, depend upon the force of the current and the nature of the accumulated debris of which it is formed. If the ground is full of large stones, consisting of fragments of rock, they will accumulate during the natural formation of the channel by the flowing stream, and thus form a more elevated, acute, and permanent ridge across the current than when the stones are of a less size and rounded by attrition. But when the bar is composed of finer gravel, it will be "more flat," will give to the rapid a greater length, and be much more "liable to shift" in times of heavy floods than the previous example.

The depths and water-level lengths of the pools ; the depths and hypotenusal lengths of the rapids from smooth water to smooth water, and the heights and lengths of the bars, require to be ascertained in the survey, and shown upon the longitudinal section ; the breadths and depths are represented upon the transverse section ; and the breadth, horizontal length, and direction of the river are shown upon the plan.

Pools, rapids, waterfalls, and cataracts are frequently known to anglers and others by their names ; and these may require to be shown both upon the plan and sections.

It is seldom found advisable to change the course of a large river in a hilly country ; on the contrary, the difficulty experienced is to confine them within the channels they have naturally scooped out for themselves ; for unless the pools are of sufficient depth, and the bars formed with proper materials, it is impossible to prevent harm in storms of more than ordinary magnitude and duration.

When a survey is undertaken for the express purpose of supplying the necessary data required for embanking a river, so as to

prevent it from overflowing its banks, and for deepening the pools and improving the rapids, so as to obviate the shifting of the channel, the height and position of the embankments, and the materials of which the bar is formed, are the first matters of inquiry that engage the attention of the surveyor.

If the river has previously been allowed to overflow its banks during heavy floods, the confining of it within embankments will raise its surface level and increase its velocity and force.

The increase in the altitude of the river, at the top of the rapid, will be found in the majority of cases to endanger the stability of the bar, and hence the safety of the channel below. This arises from the increased velocity and force being produced by artificial means, whereas the defence is natural, the bar being formed by the river when flowing at a less depth.

Sometimes the stability of the bar and rapid may be increased by artificial means sufficient to counteract a greater force of current. This is done either by throwing in heavy stones in the smooth water immediately above the rapids whose bars are liable to be washed away, or by driving in piles and wattling them with small timber.

As the breadth and depth of the river at the top of the rapid during a heavy flood are determined by the height and position of the embankments, they should be placed as far from the river's edge on both sides as the circumstances of the case will permit, the depth being inversely as the breadth.

When a river has left its bed, the same data are applicable in the formation of new bars and embankments in order to direct it back into its natural channel. Wherever the surface of the water is raised on the top of a rapid, the stability of the bar must be increased, and also the depth of the pool below; and this has to be done for several pools and rapids down the river, so as to restore the deranged balance of things to a state of equilibrium, similar to what is found in natural examples of stability.

When arable, meadow, or pasture lands have been washed away or covered with gravel, they require to be measured, so as to enable the landowner to settle questions of value with his tenants. In such cases a section to show the subsoil and drift is not unfrequently ordered.

When the course of a river has to be changed, a pool of considerable depth and length is best for the purpose, more especially if the bend is quick. A rapid should in such cases be avoided, if possible, as the concave bank and embankment are difficult to protect at the top of the rapid when the river is much swollen.



A ferry is generally at the narrowest and smoothest part of a pool, and a ford at the first smooth water immediately above a rapid; both require to be shown upon the plan, and also the ferryman's house and boat.

The piers of bridges should be protected by pools of sufficient depth to prevent harm to their foundations during the greatest flood.

Where the foundations of the piers of old bridges are so high as to form rapids, such data should be carefully shown upon the sections, and special attention drawn in any report that may accompany the survey relative to details of tear and wear, &c., that cannot be otherwise represented.

Lakes are sounded and the depths shown upon the plan, as in the case of the ocean.

In surveying waterfalls and cataracts the chief points that require attention are the peculiar geological strata of the rocks that form the bed of the river, the fracture and angles thus formed, and the wearing away of the bottom by the continuous action of the water. Such involves a large amount of work, but it is simple and easily performed by those who have a taste for drawing.

## EXAMPLE VI.

### GENERAL DIRECTIONS FOR THE SURVEY OF CANALS, IRRIGATION- WORKS, AND WARP-LANDS.

Surveys under this example are either of works that are finished or else to furnish data whereby others may be executed at some future period.

#### *Canals.*

In Canal-Surveying the levels are necessarily "water-levels" or "dead-levels," as they are sometimes termed in contradistinction from horizontal levels on which water flows.

When the canal is formed and in operation, the details of the vertical survey for the sections are of the simplest kind, as the levels can then be taken from the water, the normals from the height of the locks, and the lengths and breadths by measurement with the chain.

The details of the horizontal survey for determining the direction of the line of the canal, the area of land which it occupies, including the position of basins, quays, &c., and the severance of property which it has effected, are similar to what has already been given, and to the corresponding data in Railway-Surveying which will be found under that head, p. 385.

If the survey is made purposely to determine the levels and other data for a canal intended to be made, its details are more diversified and differ in many respects from those of a railway.

Under such conditions there are two levels given ; viz., the lowest water level, and the highest one—the object of the canal being to raise the navigation from the former to the latter by means of a series of locks and dead levels, as from *c* to *b* in the annexed diagram.

The first step in the survey is to find the difference and distance between the two given levels. This may be done either by the common levels and chain, as in the case of the river (Example IV.), or by the theodolite and chain. We shall adopt the latter, as it will illustrate a survey on the vertical plane conducted on the principles of plane trigonometry. The difference between this practice and that with the level will also be so pointed out as to be easily understood, the theodolite being in point of fact a spirit level.

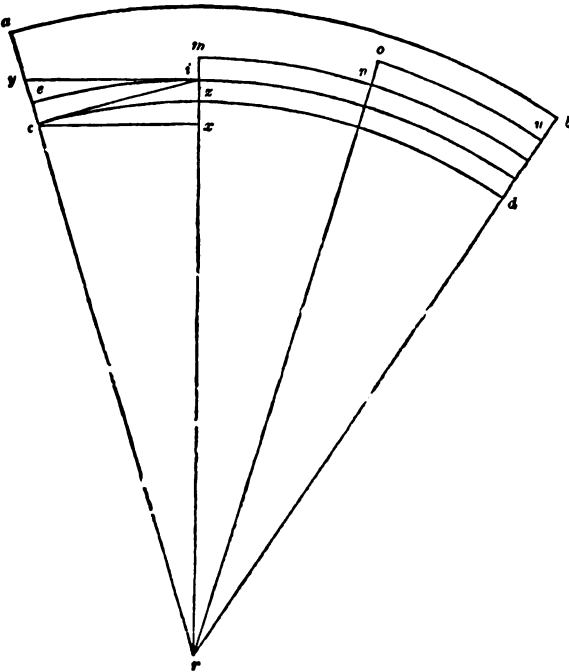

The object of taking the levels is to find the height of the upper level above the lower one, which determines the number of locks on the line, and that of measuring the hypotenusal distances with the chain to find data for ascertaining the true lengths of the dead

U

levels or arcs that determine the length of the canal within the survey.

The survey may be represented as lying between two arcs of two concentric circles on the vertical plane.

If, in the foregoing diagram (drawn on an exaggerated scale purposely to illustrate details which otherwise could not have been shown and made intelligible to the private student), we suppose  $abr$  to represent a section of the vertical plane, then  $ab$  and  $cd$  will be the two arcs between which the survey lies; the former showing the upper water level line, and the latter the lower one.

If we further suppose four locks on the line, such data will give three intervening arcs; and if we again assume that the three arcs subtend equal angles, then  $ce$  in the diagram will show the first lock,  $im$  the second,  $no$  the third, and  $ub$  the fourth:  $ei$  will show the first intervening arc,  $mn$  the second, and  $ou$  the third.

The lines sought are therefore  $bd$ ,  $ei$ ,  $mn$ , and  $ou$  on the vertical plane.

The lines measured are the hypotenusal distances, and normals or vertical-offsets, the former lying between the theodolite and levelling-staff by the chain, and the latter by the levelling-staff.

The angles measured with the theodolite are those which each hypotenusal line makes with its horizontal level or tangent and sine, and the normals or portions of the two radii between which it lies.

In the diagram the hypotenusal line between the first two radii is the diagonal  $ci$ , which represents the first line measured with the chain. The first normal taken from the levelling-staff is represented by  $cy$ . The other diagonals,  $in$  and  $nu$ , may be drawn in a similar way; also their two normals at  $i$  and  $n$ ; their two sines from  $i$  and  $n$ , and their two tangents from  $n$  and  $u$ —the construction of the second and third sector being similar to that of the first.

In each sector there are three right-angled plane triangles, and two oblique-angled triangles, with certain lines and angles, measured to find other lines and angles, by rules given in geometry and trigonometry. The triangles of the first sector only are completed, those of the other two being left for exercises to the student; and the three sectors have been made equiangular at the centre  $r$ , for the express purpose of illustrating some of the most remarkable properties of the circle, those properties most commonly met with in the practice of surveying. Two of the corresponding triangles of the three sectors are equiangular, but not equilateral, the sides increasing in length as the arcs and radii increase in length. The other three triangles are neither equiangular nor equilateral.

The three right-angled triangles in the first sector are (1)  $cxi$ , (2)  $cxr$ , and (3)  $yir$ : and the two oblique-angled triangles are (1)  $cyi$ , and (2)  $icr$ .

The two equiangular triangles are  $yir$  and  $cxr$ .

They are equiangular, *first*, because the two angles at  $i$  and  $x$  are right angles, and the angles at  $y$  and  $c$  each the complement of  $r$ , which is common to both; *second*, because  $yi$  is parallel to  $cx$ , the angle  $yir$  is equal to the angle  $xcr$  (Theor. III. Part. I.); and as the angle at  $r$  is common, and the remaining angles right angles, the triangles are therefore equiangular.

The angles of the remaining three triangles are dissimilar.

The two chief lines sought in this sector are the normal  $ce$ , representing the height of the first lock, and the arc  $ei$ , representing the length of the first level of the canal.

If we suppose the surveying-staff to be divided into two companies, one with the theodolite and levelling-staff, and the other with the chain, and that the station-poles along the canal-line are ranged, those shown on the vertical plane being  $c$ ,  $i$ ,  $n$ , and  $b$ , then the field operations will be performed and the measurements entered in the three field-books that would be open under such an hypothesis, as follows:—

At station  $c$  the angle  $yci$  is measured with the theodolite, the vertical bearing being taken from  $y$  to  $i$ . (Before removing the instrument the horizontal bearings are also taken; but as they are similar to those of the railway survey, p. 385, the directions in this section are confined to the survey of the vertical plane.) The bearings are next taken at station  $i$ ; first the angle of depression  $yic$ , which gives at the same time  $icx$ . The measurement of the angles with the theodolite, and normals with the levelling-staff, now proceed together,  $cy$  representing the first one that is found by the latter instrument. When the angle of depression  $yic$  is accurately taken and entered in the field-book, the signal is given to those in charge of the levelling-staff, who enter the height  $cy$  in their field-book, which measurement includes the height of the theodolite above the ground at station  $i$ . This latter has therefore to be taken at each angle of depression, and afterwards deducted from the former, to obtain the true normal found. The theodolite is then turned round, and the vertical bearing  $min$  taken before the station-pole is replaced. It is next removed to station  $n$ , when the levelling-staff is taken to station  $i$ .

During the above operations, the chain may be employed in measuring the side lines of the horizontal survey; but when those working the levelling-staff replace station-pole  $i$ , and proceed to  $n$ , then the diagonal or base line  $ci$  may be driven.

This concludes the field operations for the first level  $ei$  or sector  $eri$ . Those of the other two sectors  $mnr$  and  $oru$  are performed in a similar manner.

From the two angles thus measured, viz.,  $yci$  and  $yic$ , the other angles of the five triangles may be determined. Thus  $180^\circ - (yci + yic)$  gives  $cyi$  and  $xcr$ ;  $yic = icx$ ;  $90^\circ - icx = cix$ ;  $90^\circ - xcr = r$ ; and  $icx + xcr = icr$ .

From the two sides found, viz.,  $ci$  and  $cy$ , and the above angles, the other sides of the triangles may now be determined by the following formulæ:—

To find $cx$	R : cos. $icx$ ::	$ci$ : $cx$
To find $ix$	R : sin. $icx$ ::	$ci$ : $ix$
To find $xr$	R : tan. $xcr$ ::	$cx$ : $xr$
To find $rc$	$rx$ : R :: cos.	$r$ : $rc$
To find $yi$	R : tan. $r$ ::	$rx + xi$ : $yi$
To find $yr$	R : sec. $r$ ::	$rx + xi$ : $yr$ .

The two lines  $yi$  and  $ir$  may also be obtained by formulas for oblique-angled triangles, Part VIII. Section II., and the secants  $yr$  and  $cr$  by Theorem VII. Part I., as shown in Example IV. The line  $ce$  is now got by subtracting  $cr$  from  $ir$ ; and  $ey$  representing the correction for curvature of the horizontal level  $iy$  from the arc  $ei$ , is obtained by subtracting  $ir$  from  $yr$ , or the radius of the arc from its secant.

The arc  $ei$ , representing the length of the first level of the canal, remains to be determined.

The difference between radius and secant is found with geometrical accuracy in several ways, but the true length of a curve or of an arc of a circle, as  $ei$ , is only approximated. Thus, it is less than its tangent, but greater than its chord, as will be seen from the diagram. Taking the diameter, for example, to be 1, the circumference of a circle has been calculated to be 3·14159; now 3·141 would lie within the circle, while 3·142 would lie without. Between these two lesser and greater differences, another one, viz., 3·141592265358979 lies; still it is upon the inner side of the curve: and in this manner the decimal has been extended to upwards of two hundred places, and might be carried to as many more. But for all practical purposes it may be closed at 3·1416 without, or 3·1415 within, the former being generally adopted. From such data the following rules have been deduced:—

To find the circumference, multiply the diameter by 3·1416.

To find an arc, multiply ·0174533 by radius, and the number of degrees which the arc contains.

*Irrigation-works.*

Irrigation-works may be considered with a view to their survey under the following three heads :—1. Bottom irrigation ; 2. Surface irrigation ; 3. The modern system of applying liquid manure to land.

1. Extensive examples of the first kind are to be found in our West India colonies, and many other parts of the world. The works consist principally of parallel canals and ditches, intersecting comparatively level land.

The nature of the survey is therefore similar to that under Example III., the canals and ditches being used for the twofold purpose of surface drainage in the rainy season and bottom irrigation during the intervening periods of drought.

2. Surface irrigation, the second example, is principally practised for the growth of rice and grass. The water is generally conveyed to the fields in both cases by gravitation, either from canals or rivers, naturally or artificially formed, but it is differently applied afterwards, paddy fields consisting of a series of dead levels, while water-meadows lie at various inclinations.

In surveys of this kind, field operations are simple, but multitudinous in character, the levels required for distributing the water being exceedingly numerous ; and as they are represented upon the plan, they furnish a corresponding amount of office work.

3. The third practice of applying water to land is by forcing it through pipes, either by gravitation, or by steam, or other power. It may first be thrown, by means of pumping apparatus, into tanks or cisterns, situated on elevated ground, and from thence be distributed throughout the fields by gravitation ; or it may be forced directly to the land. The pipes and hydrants are ramified throughout the fields in such a manner that each of the latter has a certain area of land assigned to it, so that the liquid may be showered equally over it by means of a hose of the proper length screwed on to the hydrant. When one area is finished, the liquid is turned off, the hose screwed on to another hydrant, and thus the work proceeds until the several hydrantal areas are gone over.

It does not belong to this work to describe the details of liquid manuring land on this plan. Enough has been said to show the student who may not be acquainted with the practice the nature of the levels that have to be taken, and the survey required in laying down the pipes and hydrants.

The vertical survey closely resembles that of water-works for supplying towns, castles, farm-homesteads, and fields, with water.

It embraces two levels, a lower one at the river or fountain-head, or liquid manure tank, and a higher one at the reservoir, or its equivalent, the height to which the liquid has to be forced. The work of taking the levels is therefore similar to that in canal surveying.

With regard to the horizontal survey, a hose screwed on to a hydrant or mouth of a stopcock would distribute water over a circular area of land. The areas, however, into which fields must be subdivided are necessarily square areas; consequently each square area has to be inscribed, as it were, within the circular area which the length of the hose and jet will cover. As gases are very liable to be disengaged from drainage water and liquid manure, and to collect in the bends of pipes, where they pass over elevated ground, hydrants should be placed at such, so as to draw off the gases which there collect.

#### *Warping land.*

When flowing water holding organic and inorganic matter in suspension is turned into an area of land inclosed by embankments, and then allowed to stagnate, such matter is deposited, and termed "warp," and the process "warping."

The annual overflowing of the Nile in Egypt furnishes a practical example on a large scale. Warping has also been extensively practised in this country, the warp being chiefly obtained from tidal rivers, some of which have been termed "muddy to excess," a depth of from six to twelve inches of warp being left by them upon the land in a single summer season.

The survey is similar in character to that for embanking land when the work is not attended with any difficulty. The height and breadth of the embankments at the base are generally shown by figures upon the plan, in the same manner as the area of land inclosed for warping. As the depth of the warp will be directly as that of the water, the depths of the surface of the land at the lowest and highest places below the top of the embankment may have to be taken and shown upon the plan, as different depths of the ocean are directed to be represented in Example III. Such bottom levels are easily found by setting station-poles at the places, and raising flags or marks upon them until such marks appear in a line or in the same plane with the top of the embankment levels.

---

## SECTION IV.

THE METHOD OF REDUCING LOCAL OR CUSTOMARY MEASURES TO STATUTE MEASURE, AND VICE VERSÂ ; ALSO, THE METHOD OF REDUCING SCOTCH AND IRISH MEASURES TO STATUTE MEASURE, AND VICE VERSÂ.

It has been already observed that formerly, by custom, the perch varied in different parts of England, and with it consequently the acre also varied in proportion.

In Devonshire and part of Somersetshire 15, in Cornwall 18, in Lancashire 21, and in Cheshire and Staffordshire 24 feet were accounted a perch.

In the common field-lands of Wiltshire, and in some other counties, there was a customary measure of a different nature, viz., of 120 instead of 160 statute perches to an acre ; consequently 30 perches of statute measure made 1 rood of customary, or 3 statute roods made 1 customary acre, or 30 statute perches made 1 rood, and 4 such roods made 1 acre, customary measure.

In some places, an acre of this measure was called a day-work, or a day's work of land.

We may also observe that the customary measures of Scotland and Ireland differed very greatly from the English statute measure.

## PROBLEM I.

*To reduce customary measure to statute measure, or statute measure to customary measure.*

## GENERAL RULES.

**RULE I.** *To reduce customary measure to statute measure.*

Multiply the number of perches, customary measure, by the square feet in a square perch, customary measure ; divide the product by the square feet in a square perch, statute measure, and the quotient will be the answer in square perches, which reduce to roods and acres by dividing by 40 and by 4 in the usual manner.

**RULE II.** As the square yards in an acre, statute measure, are to the square yards in an acre, customary measure ; so are any number of acres and decimals, customary measure, to their equivalent in acres and decimals, statute measure. Then reduce the decimals to roods and perches by multiplying by 4 and by 40 in the usual manner.



NOTE 1. The roods and perches in the given quantity must be reduced to decimals of an acre before stating the question.

2. By reversing either of the preceding rules, we can reduce customary measure to statute measure.

3. It is scarcely necessary to remark that the length of any perch multiplied by itself will give the number of square feet in a square perch of the same measure; hence we have  $16\cdot5 \times 16\cdot5 = 272\cdot25$ , the statute perch;  $15 \times 15 = 225$ , the Devonshire and Somersetshire perch;  $18 \times 18 = 324$ , the Cornwall perch;  $21 \times 21 = 441$ , the Lancashire perch; and  $24 \times 24 = 576$ , the Cheshire and Staffordshire perch.

4. It may also be observed that 4840 square yards make 1 statute acre; 4000 made 1 Devonshire or Somersetshire acre; 5760 made 1 Cornwall acre; 7840 made 1 Lancashire acre; and 10240 square yards made 1 acre of the customary measure of Cheshire or Staffordshire. Also, 3630 square yards made 1 acre of the customary measure of Wiltshire.

5. When it was intended to find the area of an estate in customary measure only, it was generally thought most convenient to take the dimensions by a chain properly adapted for that purpose. The Devonshire and Somerset chain was 60 feet; the Cornwall chain, 72 feet; the Lancashire chain, 84 feet; and the Cheshire and Staffordshire chain, 96 feet in length. Each of these chains was divided into 100 equal links, in the same manner as the statute-chain; consequently the customary measure was found by the same rules as the statute measure.

6. It may also be observed that the Devonshire and Somersetshire link was 7·2 inches; the Cornwall link 8·64 inches; the Lancashire link 10·08 inches; and the Cheshire and Staffordshire link was 11·52 inches in length.

### *Examples.*

*Ex. 1.* In 32 acres 2 roods and 20 perches, Devonshire and Somersetshire customary measure, how many acres, &c., statute measure?

By Rule I. Here,  $32a. 2r. 20p. = 5220$  customary perches; and  $5220 \times 225 = 1174500$ , the square feet in 5220 customary perches; then,  $1174500 \div 272\cdot25 = 4314$  statute perches =  $26a. 3r. 34p.$ , statute measure.

By Rule II. Here,  $32a. 2r. 20p. = 32\cdot625$  acres; then, as  $4840 yds. : 4000 yds. :: 32\cdot625a. : 26\cdot96281a. = 26a. 3r. 34p.$ , statute measure, the same as by Rule I.

*Proof.* As  $4000 yds. : 4840 yds. :: 26\cdot96281a. : 32\cdot625a. = 32a. 2r. 20p.$ , customary measure, the same as given in the question; and obtained here by reversing Rule II.

*Ex. 2.* In 45 acres 3 roods and 15 perches, Wiltshire customary measure, how much statute measure?

By Rule II. Here,  $45a. 3r. 15p. = 45\cdot875$  customary acres; then, as  $4840 yds. : 3630 yds. :: 45\cdot875a. : 34\cdot40625a. = 34a. 1r. 15p.$ , statute measure.

*Proof.* As  $3630 yds. : 4840 yds. :: 34\cdot40625a. : 45\cdot875a. = 45a. 3r. 15p.$  customary measure, the same as given in the question.

**NOTE.**—In solving this and every similar question, the learner must recollect that 30 perches make 1 rood, Wiltshire customary measure. (See the Introduction to this Section.)

*Examples for practice.*

1. Reduce 47a. 3r. 20p., Cornwall customary measure, to statute measure. *Ans.* 56a. 3r. 36p.

2. Reduce 22a. 1r. 27p. Lancashire customary measure, to statute measure. *Ans.* 36a. 1r. 10·3p.

3. Reduce 127a. 1r. 26p. Cheshire and Staffordshire customary measure, to statute measure. *Ans.* 269a. 2r. 1·07p.

4. How many statute acres are contained in 53a. 2r. 20p. of the customary measure of Wiltshire? *Ans.* 40a. 1r. 0p.

5. A gentleman's estate near Manchester, according to an ancient plan and survey, contains 345a. 2r. 30p. Lancashire customary measure, what is its content in statute measure?

*Ans.* 559a. 3r. 30p.

6. A gentleman's estate near Chester contains 436a. 3r. 36p. Cheshire customary measure, and is let at £8 10s. 6d. per acre per annum; what would be an equivalent rent per acre, if the estate were let by the statute acre?

*Ans.* £4 0s. 7d. per acre, statute measure.

PROBLEM II.

*To reduce Scotch and Irish land measures to English statute measure; and vice versâ.*

The Scotch chain, by which land was formerly measured in Scotland, was divided into 100 links, in the same manner as the English statute chain; but the Scotch link was 8·88 inches in length; consequently the length of the chain was 888 inches, or 74 feet English measure.

The Scotch fall or perch was 18·5 feet in length; and hence the square fall or perch contained 342·25 square feet; and 40 falls or perches made 1 rood, and 4 roods made 1 acre. Also, 160 falls or perches made 1 acre; and consequently the *Scotch acre* contained 6084½ square yards English measure.

The Irish chain was also divided into 100 links, each link being 10·08 inches in length; and consequently the length of the chain was 1008 inches, or 84 feet English measure.

The Irish perch was 21 feet in length, and hence the square perch contained 441 square feet, and 40 perches made 1 rood, and 4 roods made 1 acre. Also, 160 perches made 1 acre; and con-

sequently the *Irish acre* contained 7840 square yards, English measure.

NOTE 1.—The general rules given in the first problem may be applied to the reduction of both Scotch and Irish measures. Or, multiply Scotch acres by 1·25712, and Irish acres by 1·61983, and the respective products will be English statute acres. Also, if English statute acres be divided by these numbers, the respective quotients will be Scotch and Irish acres.

2. As both the Scotch and Irish chains were divided into 100 links, in the same manner as the English chain, it is manifest that the rules given in this work for finding the areas of different figures, and for laying-out, parting-off, and dividing land, were equally applicable in all cases of surveying, whether the dimensions were taken with the English, Scotch, or Irish chain.

3. The Scotch acre contained 1244½ square yards, and the Irish acre 3000 square yards more than the English statute acre. It also appears that the Irish measure was the same as the Lancashire customary measure.

4. The Scotch mile was 1973½, and the Irish mile 2240 English yards; and hence it appears that the Scotch mile was 213½, and the Irish mile 480 yards more than the English mile.

#### *Examples.*

*Ex. 1.* Reduce 36*a.* 1*r.* 10*p.* Scotch measure to English statute measure.

By Rule 1. Prob. I. Here, 36*a.* 1*r.* 10*p.* = 5810 Scotch perches; and  $5810 \times 342\cdot25 = 1988472\cdot5$  square feet in 5810 perches; then  $1988472\cdot5 \div 272\cdot25 = 7303\cdot8$  perches = 45*a.* 2*r.* 23·8*p.* statute measure.

By Note 1. Prob. II. Here, 36*a.* 1*r.* 10*p.* = 36·3125*a.*, and  $36\cdot3125 \times 1\cdot25712 = 45\cdot64917*a.*$  = 45*a.* 2*r.* 23·8*p.* statute measure.

*Ex. 2.* Reduce 36*a.* 1*r.* 10*p.* Irish measure to English statute measure. *Ans.* 58*a.* 3*r.* 11*p.*

*Ex. 3.* The length of a rectangular field measured by the English statute chain is 1435 links, and its breadth 923 links; required the area of the field in English, Scotch, and Irish measures.

*Ans.* 13*a.* 0*r.* 39*p.* English measure; 10*a.* 2*r.* 5½*p.* Scotch measure; and 8*a.* 0*r.* 28½*p.* Irish measure.

#### REMARK.

The preceding problems and examples will be found useful, not only in reducing customary measures to English statute measure, but also in conveying information to our young surveyors relating to *ancient measures*, which will soon become only matters of history.

## ESTIMATING LAND BY THE MILE.

*The method of making a rough calculation of the number of acres contained in a Common, Moor, Lordship, County, or Kingdom.*

Endeavour to ascertain in miles, as nearly as you can, either by your own observations or from the information of others, the mean length and breadth of the land to be estimated; then multiply the length by the breadth, and the product will be the area in square miles. Multiply this area by 640, the number of acres in a square mile, and the product thus obtained will be the area in acres, according to this method of calculating.

NOTE 1. The mean length and breadth of a county or a kingdom may be found from a map, in the following manner:—Measure several lengths by the scale of miles upon the map; add them together; and divide their sum by their number for a mean length. A mean breadth may be obtained by a similar process.

2. The foregoing method of finding the area of counties and kingdoms must, of course, be liable to considerable inaccuracy, not only as regards the method of taking the dimensions, but also as respects the correctness of the map and scale; for it is evident that if these be not truly delineated, the dimensions can never be obtained to any degree of accuracy.

3. When you have a correct map and scale of a county or a kingdom, its content may be found to a considerable degree of accuracy by the following method:—Divide the map into triangles and trapeziums in the most convenient manner, and straighten the crooked shores or coasts, either with a lantern horn, as directed in Part IV., or by the parallel ruler, as directed in Part V. Measure the bases, diagonals, and perpendiculars correctly, by the scale of miles belonging to the map; find the area of each figure separately; and the sum of these areas will be the whole area required.

*Examples.*

1. Suppose the mean length of a common or moor be estimated at  $3\frac{3}{4}$  miles, and its mean breadth at  $2\frac{1}{4}$  miles, what is the area in acres, according to this estimation?

$$\begin{array}{r}
 \text{miles.} \\
 3\cdot75 \\
 2\cdot25 \\
 \hline
 1875 \\
 750 \\
 750 \\
 \hline
 8\cdot4375 \text{ miles.} \\
 640 \\
 \hline
 3375000 \\
 506250 \\
 \hline
 5400\text{-}0000 \text{ acres.} \\
 \text{Ans. } 5400 \text{ acres.}
 \end{array}$$

2. If the mean length of a lordship be estimated at  $4\frac{1}{2}$  miles, and its mean breadth at  $2\frac{1}{2}$  miles; what is the content in miles and acres?

*Ans. 10·625 miles and 6800 acres.*

3. The mean length of a county, found from a map, is 63 miles, and its mean breadth 42 miles; what is its area in miles and acres?

*Ans. 2646 miles and 1693440 acres.*

4. According to Parliamentary Papers 1861, the content of Ireland is computed at 32·518 square miles; what is its area in acres?

*Ans. 20·811520 acres.*

5. According to Parliamentary Papers, the content of Scotland is computed at 31·324 square miles; required its area in acres.

*Ans. 20·047360 acres.*

6. According to Parliamentary Papers 1861, the extent of England and Wales is computed at 58,319 square miles; what is the area in acres?

*Ans. 37·324160 acres.*

NOTE.—The county maps of the Ordnance Survey may be taken as examples for exercises.

## PART VII.

THE METHOD OF MEASURING AND PLANNING MANSIONS, HOMESTEADS, VILLAGES, TOWNS, AND CITIES; DIRECTIONS FOR MEASURING AND PLANNING BUILDING GROUND, AND DIVIDING IT INTO CONVENIENT LOTS FOR SALE; AND MISCELLANEOUS QUESTIONS RELATING TO SURVEYING, LAYING-OUT, PARTING-OFF, AND DIVIDING LAND.

### SECTION I.

THE METHOD OF MEASURING AND PLANNING VILLAGES, TOWNS, AND CITIES.

Villages, towns, or cities, mansions, and farm-homesteads, present themselves in almost every extensive survey, and are generally measured and planned with the adjoining or surrounding lands. The method of taking and laying down the dimensions of such places, and finishing the plans, will be given in the following sections.

Besides the plans of towns and cities are so essentially necessary for the purposes of commercial and general reference, that surveyors are not unfrequently employed in forming correct drawings

of the same, in order to have them engraved and published in copperplates.

Without this art, we could not obtain the ichnography of towns and cities ; neither could we have any just idea of the shape, extent, and direction of the streets ; the size and number of the public buildings ; the local conveniences enjoyed by the inhabitants, &c., of those places which circumstances will not permit us to visit.

*Directions for taking the dimensions of villages, towns, and cities.*

The dimensions of villages, towns, and cities, may generally be obtained by the chain only, as the streets are usually wide enough to admit of angles or tie-lines being taken at the meetings or inter-sections, in the same manner as directed in Problems IV. and V., Part IV. In these Problems the methods of measuring meres, woods, roads, rivers, and canals, are illustrated ; and as the learner becomes completely master of this branch of surveying, any difficulties that present themselves in measuring will be easily surmounted.

It sometimes happens that the tie-lines cannot be measured at a greater distance from the angular points than 30 or 40 links. In such cases the tie-lines must be taken to a quarter of a link, and both them and the angular distances must be multiplied by 2, 3, 4, or any larger number, as circumstances may require ; and the products used in laying down the chain-lines. (See Problem II. Part IV.)

The notes taken in measuring towns and cities must be entered precisely in the same manner as in surveying estates ; and in measuring along the streets offsets must be taken to the houses on both sides of the chain-line, and particularly to every corner and projection ; even the small projections of bow-windows must not be omitted.

Sketches of the bases of the buildings, particularly the corners and projections, must be made in the margin of the note-book, in order to assist the surveyor in drawing a correct plan.

All public buildings, such as churches, prisons, castles, court-houses, market-places, halls, colleges, mansion-houses, &c., must be distinctly noticed ; and the range of the first line should be taken with the compass, in order that the draughtsman may be able to lay down every street in its true direction.

NOTE 1. In measuring along the streets, all the offsets to the buildings must be taken at right angles to the chain-lines. The bases of the buildings and all the projections must be sketched as you proceed ; and the breadths of the buildings, the lengths and breadths of the projections, &c., must be correctly measured and entered opposite to those parts of the sketch to which they respectively belong. The sign + (plus) is usually placed between the breadth of a building, at its

perpendicular distance from the chain-line. The method of sketching the bases of buildings, and entering the notes, is exemplified in pages 4, 10, and 12, of the engraved field-book, to which the learner is referred. (See also Plate VII. No. 7, page 199.)

2. When a town and the surrounding or adjoining lands are both to be measured and planned together, the dimensions must be taken with Gunter's chain; and the lines measured along the streets must be properly connected with those measured in surveying the adjoining estates; but if the plan of a town only is required, it is more convenient to take the dimensions with a chain of 50 feet in length, divided into 50 links, and an offset-staff of 10 feet in length.

3. As station staves cannot always be fixed in the streets, in consequence of the pavement, they must either be set in pedestals made for that purpose, or two or more assistants must each hold a staff in those places that are pointed out by the surveyor.

4. Sometimes it is most convenient to measure external or main-lines on the outside of the town, as in surveying a mere or wood (Prob. IV. Part IV.); and in running such lines, stations must be left at the end of the streets, as you pass them, in order that lines may be run from one station to another in measuring the streets.

5. In some situations, and under certain circumstances, it is more eligible to measure the first line along one of the principal streets, and to intersect this line by another, measured along some other principal street, nearly at right angles with the former; then these two lines being tied together by a connecting line, measured in the most convenient manner, will divide the town into four parts, each of which may be measured separately by running lines in the most advantageous manner.

6. In putting down stations at the ends of the streets, &c., the number of the station may be made upon the wall of the opposite building (if there be one) with red or white chalk, in such a situation that an offset may be taken, at right angles to the building, from the station marked upon the wall to the station on the chain-line. This offset being entered in the book, and again measured from the station on the wall, at right angles to the building, will give you the station on the chain-line whenever you may want to find it.

7. When the foregoing method cannot be adopted, in consequence of not being able to take a right-angled offset from any building to the station which you wish to fix, then two lines may be measured from the station to the corners, or to any other parts of two adjoining buildings; and the intersection of these lines, when measured from the buildings, will give the station required.

8. After all the principal streets have been measured, then proceed to the smaller and intermediate streets; and lastly to the lanes, alleys, courts, yards, and every other part which it may be thought necessary to represent upon the plan.

9. When any of the streets are so narrow as not to admit of tie-lines being taken with the chain, the angles which the chain-lines make with each other, at the meetings or intersections of the streets, must be taken in degrees and minutes by a theodolite; and in planning, they must be laid down as directed in Problems XX. and XXI. Part I.

10. What has been advanced on this subject will, no doubt, be acceptable to learners; but as towns are built after such a variety of plans, and consequently vary so much in their forms, no directions can be given that will be applicable

to every particular case to be met with in practice. A great deal will always depend upon the skill and judgment of the surveyor, who should, after duly examining every part of the town, endeavour to run his lines in the most advantageous manner.

*Examples.*

Let it be required to measure the New Town, No. 7, Plate VII.

In order to follow the method described in Note 4, we shall begin at the south-west corner, as in Problem IV. Part IV.; although the survey would be conducted precisely in the same manner if we began at any other corner.

*1st Line.* Put down + 1, at the SW. corner, and proceed towards the SE. corner; taking offsets to the buildings, wherever it is necessary, and sketching their bases in the margin of the notebook. At the end of High Street, put down + 2; at Queen Street, + 3; at Low Street, + 4; at the SE. corner, + 5; and produce the line at pleasure to + 6.

*2nd Line.* From + 5 proceed towards the NE. corner, but when you arrive at the end of York Street, put down + 7, and thence run a tie-line to + 6. From + 7 proceed with the main-line, and at King Street put down + 8; at George Street, + 9; at the NE. corner, + 10; and continue the line to + 11.

*3rd Line.* From + 10 go towards the NW. corner; but when you come to the end of Low Street put down + 12, from which run a tie-line to + 11. Proceed from + 12, and at the end of Queen Street put down + 13; at High Street, + 14; and at the NW. corner, + 15.

*4th Line.* From + 15 proceed towards the SW. corner; and at the end of George Street put down + 16; at King Street, + 17; at York Street, + 18; and continuing the line to + 1, you will have circumscribed the town with four main-lines into which the lines measured along the streets must be run.

**NOTE.**—After the first three lines are laid down, it is evident that the fourth line will serve as a check, and will reach exactly from + 15 to + 1, if all the operations have been conducted with accuracy.

*5th Line.* From + 18, through York Street, to + 7.

*6th Line.* From + 8, along King Street, to + 17.

*7th Line.* From + 16, through George Street, to + 9.

*8th Line.* From + 12, along Low Street, to + 4.

*9th Line.* From + 3, through Queen Street, to + 13.

*10th Line.* From + 14, along High Street, to + 2; thus the survey of the town is completed.

**NOTE 1.** The chain-lines and stations do not appear upon the plan, as they could not have been conveniently entered without increasing its size; the



learner will, however, find no difficulty in making a similar plan, two or three times as large; drawing the chain-lines, and putting down the stations in their proper places. Or he may take the dimensions of the given plan with a small scale, enter them in a note-book, and then draw a rough plan by a larger scale, and after that a finished one, which will be an exercise that will tend much to his improvement.

2. The survey of this town might have been carried on according to the directions given in Note 5, by measuring a line through King Street, and another through Queen Street; and then connecting these two lines together by tie-lines taken at the point of intersection.

3. Here it will be proper to observe that in taking an angle with the chain or theodolite, at the intersection or meeting of two lines, either the external or internal angle may be taken, as circumstances may make it most convenient; but it should always be remembered, that neither very acute, nor very obtuse angles should be measured, if it can be avoided, as both are liable to errors in laying down. Those angles which approach nearest to right angles should always be preferred as being most correct.

4. By way of proof it is an excellent plan to take both the angles. If they be taken by the chain, you will have a check-line by the scale; and if taken by the theodolite, their sum should be 180 degrees; and you will also have a proof in planning, in consequence of having measured an angle and its supplement. (See Definition 16, and Problems XX. and XXI.)

*Directions for surveying and planning mansions, farm-buildings,  
stack-yards, &c.*

Landed estates, generally speaking, have mansions for their proprietors, and homesteads for tenants, and these occupy a prominent place on every plan.

In a survey, one of two ways may be ordered. *First*, a new site for a homestead or mansion may be proposed, involving the resub-division of the land by new fences and roads; *second*, such improvements may be finished before the surveyor is employed.

Under the *first proposition*, the chief points that engage attention are, first, the form of position of buildings and fields; second, the site of the homestead and labourers' cottages; third, water for cattle, irrigation, and machinery; and fourth, roads: under the *second proposition*, surveying and planning only are involved.

1. A modern farm-homestead may be considered a manufactory consisting of a rectangular block of buildings, requiring for a site an area of land of a similar form, and in size according to the size of the form and number of cattle kept.

When the cattle-yards are roofed over, the position of the houses is of little moment, but when open they should have a southern exposure.

Rectangular fields are to be preferred, and fences should run north and south, east and west. But this position, although the most

favourable, is not always practicable, so that every individual case must be its own rule.

When the front of the houses does not run parallel to the fence opposite, there will be a triangular piece of land on each side to appropriate to some useful purpose. To throw such pieces into the adjoining fields would, in many cases, destroy their appearance and make them a perpetual eyesore, and what is worse, more expensive to labour. Small paddocks for calves, or for liquid manuring and soiling, if properly managed, are always the best paying land on the farm, and highly ornamental if well laid out; so that by such means every inch of land about the homestead can be turned to the best advantage.

2. The farm homestead and labourers' cottages should be centrally situated, but in practice the *third* and *fourth* points generally determine the sites of both upon a farm.

3. Water for the homestead, the cottages and fields being invaluable, is the first thing that should engage attention. The means of supply, be it pump or otherwise, should never be omitted, and when the water is conveyed from a distance, the fountain-head and direction of the pipes should also be indicated upon the plan. When a sufficient supply can be had for irrigation, or for water power, the same rules apply to water-courses, mill-dams, &c.

4. Roads and tramways for traction engines should be laid out on the same principles as railroads relative to levels. In many cases, therefore, their direction will not only determine the site of the homestead, but also the range of the fences.

When the farm has only to be surveyed and planned, it is usual to range one of the lines close past the homestead, so that the ground plan of the buildings can be laid down from it, as in the preceding example of a new town, No. 7, Plate VII. Part V.

The home farm of the landowner can be surveyed and planned as above, but improvements in connexion with the mansion, &c., involve much ornamental work, for which no general directions can be given. When the surrounding grounds are extensive and thickly wooded, some difficulty may be experienced in ranging lines and driving them with the chain, but the bearings can always be taken from some eminence by the theodolite, according to Section VI., Part IX., and the details easily worked out with the chain and plotting scales afterwards.

*Directions for planning villages, towns, and cities.*

All the main-lines must first be laid down, and the stations upon them marked off. The lines measured along the streets must then be

drawn, and the stations upon them denoted. The bases of the buildings must next be laid down from the offsets, so as to form the streets, and shaded as directed in Part V., and exhibited in Plate VII. The rough plan must then be transferred to a clean sheet, by some of the methods described in Part V., in order to make a finished plan.

The bases of all public buildings, such as churches, castles, prisons, session-houses, market-places, infirmaries, hospitals, mansion-houses, monuments, &c., should be delineated upon the plan with the utmost correctness; and most surveyors draw the bases of the columns which support the roofs of market-crosses, the galleries of churches, &c., as exhibited in the plate to which we last referred.

The streets are usually left white; but some draughtsmen prefer colouring the causeways with a tint of blue to distinguish them from the carriage-roads, which are generally washed with a yellowish brown.

The grass-plots in gardens, public squares, &c., whether they be rectangles, rhombuses, circles, ovals or regular polygons, should be correctly delineated upon the plan; then shaded with Indian ink and washed with green, in the same manner as pasture grounds; and trees, water, pleasure-grounds, gardens, gravel-walks, &c., must be shaded and coloured as directed in Part V.

The name of the village, town, or city should be given in conspicuous characters, in some vacant part of the plan or map; and the names of all the streets, public squares, churches, colleges, halls, prisons, castles, court-houses, mansion-houses, market-places, lanes, alleys, courts, yards, &c., must be entered in their respective situations in the manner exhibited in Plate VII.

**NOTE 1.** If the dimensions be taken and laid down in feet, a scale of feet must be given; if in yards, a scale of yards must be given; if in chains and links, a scale of chains and links must be given; and if the town or city be very large, a scale of miles and furlongs may be given upon the plan, for the purpose of measuring distances; and as 220 yards make a furlong, the distance of one place from another may be easily obtained in miles and yards.

2. Any remarks or explanations that it may be thought necessary to give, may be entered in some vacant corner of the plan.

3. All plans, ornaments, &c., should first be drawn in pencil; and it will tend much to the improvement of the learner, if he form all his printing, German text, and large-hand letters by the pencil also, and then finish them with Indian ink.

4. In forming letters, ornaments, &c., with the pencil, the lines and strokes should be made as fine as possible, as the ink frequently runs upon the lead when the pencil has been used too freely; hence the necessity of applying Indian rubber after the outlines have been finely drawn with Indian ink, in order to remove the lead which is not covered by the ink, before we proceed to finish the letters, ornaments, &c.

5. If the pupil does not succeed well in his first attempt with the pencil, the letters, ornaments, &c., must be effaced with Indian rubber; and he must repeat the process until he can form all the letters, devices, &c., correctly.

6. Properly prepared lead pencils are essential for fine drawing, and will be found to answer well in making letters, ornaments, &c., when they are of a middling degree of hardness; because the marks made by them may be easily effaced.

7. After practice has made the learner a proficient in penmanship, he will be able to print text, and write more expeditiously without the use of the pencil.

8. Here it may not be improper to caution the learner against a very common fault of young draughtsmen; namely, that of making their lines and letters too strong, both with pencil and ink.

9. Engraven plans of towns, &c., as copy-books, may now be had in almost every county town in the kingdom, and if the learner can get possession of a plan of a place with which he is personally familiar, the example will be none the less interesting and instructive. And besides the ground plans of towns delineating the bases of houses, the areas of streets, parks, &c., those of large farmeries, with their outbuildings, gardens, and small paddocks adjoining, covering altogether an area of several acres of land, are not unfrequently called for on a larger scale than is exemplified on the general plan or atlas of the estate. This is more especially the case as to the ground plans and isometrical views of the mansion, gardens, pleasure-grounds, and buildings of the home farm of the proprietor. Engraven plans of many of these, and designs for an indefinite number more, are now accessible, and may be studied with advantage, and even transferred to drawing paper on a different scale. Nor is it advisable that the learner should exclusively confine his source of information to engraven plans, for many (especially farmers' and land-surveyors' sons) may very profitably get for an exercise to give in to their teachers a ground plan and view of their parents' homesteads or residences. Boys are generally fond of drawing, so that the more rudimentary period of education passes over smoothly, but when they advance to what may be termed *usefulness*, the measuring of the garden and the laying it down with mathematical accuracy upon a base line, is often surrounded with greater difficulty; but they should ever bear in mind that it is upon this latter that their professional eminence in surveying is to depend.

#### TO CLEAN PLANS OR MAPS.

It has already been intimated to the young draughtsman, that every precaution should be taken to keep plans and maps clean in executing them; but notwithstanding the greatest possible care, they will generally be somewhat soiled, both upon the face and back (perhaps in consequence of misfortunes), either by dust, ink, or colours; hence it is necessary to clean them before they are delivered.

*To clean plans or maps that are soiled with dust, Indian ink, or colours.*

Take a sharp penknife, with a roundish point, and scrape those parts gently which are besmeared with ink or colours, until you

efface the blots ; then use clean Indian rubber freely to those places that are soiled with dust ; and lastly, rub the whole map well with white bread, taking care to pare the bread as it accumulates the dust.

NOTE 1. Indian rubber is made from the juice of a large tree, which grows in South America, Java, and India. The juice is obtained by making incisions through the bark of the tree. From the wounds thus formed the juice flows abundantly. It is usually brought to Europe in the form of pear-shaped bottles, which are made by spreading the juice over moulds of clay. These are dried in various ways according to the season. This done, the clay in the inside is then picked out by instruments.

2. When Indian rubber has become foul by frequent use, it may be cleaned by washing it in lukewarm water and soap.

*To clean plans or maps that are blotted with common ink.*

If the blots be light, they may be scraped out with a penknife, or effaced by rubbing them repeatedly with clean paper wet in water or saliva ; but when they are deep, acid or salt of lemons must be used in the following manner : Dissolve a small portion of the acid in hot water, and with a clean hair-pencil, dipped in the solution, wash the blots until they are removed.

NOTE 1. Recent blots are easily obliterated ; but when they are old, and very deep, it will be found necessary to let the paper dry, and repeat the wash several times. Salt of lemons is sold in small boxes by druggists.

2. When you have to write upon those places from which the blots have been removed, the paper will bear the ink better if you rub a little pounce upon it with clean paper, and then smooth it with your folder, or with the haft of your penknife. Sometimes the paper will bear the ink pretty well, after a blot has been removed, by merely smoothing it as above directed.

3. Pounce or gum sandarach is a resinous gum which exudes from the juniper-tree, and is of a pale yellowish colour. It is imported in small pieces or tears, about the size of peas ; and when reduced to powder, and passed through a fine sieve, it is used for rubbing upon writing paper, in places where any blot or writing has been scraped out.

4. Sometimes a spurious kind of pounce is made by reducing resin (the juice of the Scotch fir) to a powder ; but this should never be used, as it is too gummy. It may be known from genuine pounce by being of a darker yellow, and having a stronger odour.

5. Large blots of Indian ink, common ink, or colours may be removed from maps or strong drawing paper by washing them repeatedly with a sponge and clear water, always taking care to squeeze and wash the sponge as it absorbs the ink or colours ; repeating the process until the blots disappear.

6. Sponge is a kind of marine animal production, a species of the class polypi, found adhering to rocks, shells, &c., chiefly in the Mediterranean Sea. The best sponges are those which are white, light, and have the holes small, and near to each other.

7. Sponge is much used by landscape painters, in washing their pieces with water, after they have finished shading them with neutral tint. This process removes the superabounding shade, discharges the clouds, produces a remarkable softness, and prepares the pieces for taking the colours with ease and freedom.

## SECTION II.

DIRECTIONS FOR MEASURING AND PLANNING BUILDING-GROUND, AND DIVIDING IT INTO CONVENIENT LOTS FOR SALE.

*Directions for measuring building-ground.*

Land lying in the vicinity of large towns is frequently sold by the square yard, for building-ground ; and as it always bears a high price when the situation is eligible, it is of the greatest importance, both to the buyer and seller, to ascertain its contents with the utmost accuracy.

In order to accomplish this desirable object, the dimensions should be very correctly taken with a measuring-tape divided into yards, tenths, and hundredths ; or with a tape divided into feet and tenths, or feet and inches.

When the dimensions are taken in feet and inches, the inches must be reduced to the decimal parts of a foot : and the area found from such dimensions must be divided by 9, to bring it into square yards.

Whatever be the shape of the ground to be measured, it must be divided into such squares, rectangles, trapezoids, trapeziums, or triangles as will give the true content of the whole : and if the side be crooked, offsets must be taken, as directed in Problem VI. Part III.

Narrow pieces of building-ground must be measured by Problem VII. ; and if they be very irregular, their areas may be correctly found by the method of equidistant ordinates described in Problem IX., Part III.

NOTE 1. As a measuring tape is not so convenient in taking the dimensions of land as a chain, it is more eligible to use the latter when the land to be measured is extensive ; the greatest care, however, must be used in order to obtain the dimensions correctly, which should be taken to a quarter of a link.

2. The chain must be completely stretched, and held at the bottom of the arrows in measuring ; and if it be an inch or two overlong, an allowance must be made in the dimensions ; thus, if a line 650 links be measured by a chain that is  $2\frac{1}{2}$  inches above 66 feet, we shall have  $6\frac{1}{2} \times 2\frac{1}{2} = 16\frac{1}{4}$  inches = 2 links *nearly* ; hence the true length of the line will be 652 links.

3. The above method may also be adopted in measuring land, when it is found necessary to correct the dimensions taken by a chain that exceeds the proper length.

4. As 4840 square yards make 1 acre, 1210 square yards, 1 rood, and  $30\frac{1}{2}$  square yards, 1 perch, we can easily reduce acres, roods, and perches to square yards, in the following manner: Multiply 4840 by the number of acres; 1210 by the number of roods; and  $30\cdot25$  by the number of perches; then the sum of these three products will be the square yards required.

5. When the area is in square links, divide it by 20·6611, the number of square links in a square yard; and the quotient will be the area in square yards. (See the Table of Square Measures in Part III).

6. Building-ground is generally sold in small parcels. Sometimes, however, it is sold by whole fields together, which are afterwards divided by the buyer, and retailed out in small lots.

### Examples.

1. The length of a rectangular piece of building-ground is 65·8 yards, and its breadth 32·6 yards; what is its area in square yards, and its value at 5s. 9d. per square yard?

$$\begin{array}{r}
 \text{yds.} \\
 65\cdot8 \\
 \underline{32\cdot6} \\
 3948 \\
 1316 \\
 \underline{1974} \\
 2145\cdot08 \text{ area}
 \end{array}$$

$$\begin{array}{ccccccc}
 \text{yds.} & \text{s.} & \text{yds.} & \text{£} & \text{s.} & \text{d.} & \\
 \text{As } 1 & : & 5\cdot75 & : & 2145\cdot08 & : & 616 \quad 14 \quad 2\frac{1}{2} \text{ the value.}
 \end{array}$$

2. The length of a rectangle measures 85·36, and its breadth 43·28 yards; what is its area in square yards, and its value at 6s. 3d. per square yard?

*Ans.* The area is 1694·3808 square yards; and the value of the land 1154l. 9s.  $10\frac{1}{2}$ d.

3. The parallel sides of a piece of ground in the form of a trapezoid measure 84·63 and 72·78 yards, and the perpendicular distance between them 56·59 yards; what is its area in square yards?

*Ans.* 4453·91595 square yards.

4. The diagonal of a trapezium measures 236·5 feet, one of the perpendiculars 189·3 feet, and the other 127·9 feet; what is its area in square yards, and its value at 1l. 6s. 6d. per square yard?

*Ans.* The area is 4167·655 square yards; and the value of the ground 5522l. 2s.  $10\frac{1}{2}$ d.

5. The base of a triangle measures 369·9 feet, and the perpendicular 234·7 feet; what is its area in square yards, and its value at 2s. 6d. per square yard?

*Ans.* The area is 4823·085 square yards : and the value 602*l.* 17*s.* 8½*d.*

6. The three sides of a triangle measure 362 feet 3 inches, 316 feet 6 inches, and 284 feet 9 inches respectively ; what is its area in square yards?

*Ans.* By Note 4, Part IV., you will find the area to be 4810 square yards.

7. Draw a plan of an irregular piece of land, and find its area in square yards, from the following dimensions, taken in feet.

	AB	
0	1286	145·6
247·6	1015	
	987	59·8
	790	136·5
317·6	720	
	560	164·2
223·5	465	
	346	124·8
345·2	268	
372·4	000	245·3
Begin at	A	and go West.

*Answer.*

Double areas

359147·3 offsets on the right

676164·8 ditto on the left

2)1035312·1 sum

9)517546·05 area in square feet

57517·33 ditto in square yards.

8. Required the plan of a piece of building-ground, and also its area in square yards, from the following equidistant ordinates, taken in feet.

	AB	
255·8	1000	
250·6	900	
246·3	800	
235·4	700	
221·2	600	
201·9	500	
176·8	400	
168·5	300	
157·7	200	
146·0	100	
139·1	000	
Begin at	A	and range East.



*Answer.*

394·9 the first and last ordinates  
 4009·6 four times the sum, &c.  
1604·0 twice the sum, &c.  
 6008·5 sum total  
     100 the common distance  
 3)600850·0  
 9)200283·3 area in square feet  
22253·7 ditto in square yards.

9. Required the plan of a piece of ground, and likewise its area in square yards, from the following dimensions, taken in feet.

	BC	
0·0	846	
33·2	700	
66·4	600	
74·8	500	
85·6	400	
62·3	300	
50·7	200	
25·9	100	
0·0	000	
	R. off B	
	AB	
	1253	
	1000	
	586	
Begin at	A	525·6 C and go West.

*Answer.*

Double areas  
 658576·8 triangle ABC  
81307·2 offsets on BC  
 2)739884·0  
 9)369942·0 area in square feet  
41104·6 ditto in square yards.

10. Required the plan of a portion of building-ground, and also its area in square yards, from the following dimensions, taken by Gunter's chain; likewise its value, supposing it to have been sold by auction at 14s. 9d. per square yard.

	BD 1235 1075 270 R. off B	474½ A
C 482½		
	AB 1175 1100 1000 900 800 700 600 500 400 300 200 100 0 000	
22½ 25½ 45½ 40½ 54½ 68½ 70½ 65½ 60½ 55½ 40½ 32½ 0		
Begin at		A and go West.

NOTE.—In calculating the area, the quarter-links must be treated as decimals.

*Answer.*

Double areas

1181895·00 trapezium ABCD

112881·25 offsets on AB

2)1294776·25 sum

647388·125 area in square links.

By note 5, we have  $647388·125 \div 20·6611 = 31333·67$ , the area in square yards; then, as 1 yd. : 14·75s. :: 31333·67 yds. : 462171·6325s. = 23108l. 11s. 7½d., the value required.

*Directions for planning building-ground, and dividing it into convenient lots for sale.*

Building-ground may be laid down by a plotting-scale, whether the dimensions be taken in yards or in feet, by calling each chain upon the scale one yard, or one foot, as the case requires; and the intermediate divisions will evidently be tenths of a yard, or tenths of a foot.

If the plot of ground be small, the scale made choice of should be pretty large, so as to exhibit every part of the ground distinctly.

After the plan has been drawn, the ground must be judiciously divided and laid out, by making streets at a proper distance from each other; and then subdivided into convenient parcels or lots for

sale according to the situation of the place and the size of the houses for which the ground is best adapted.

Main or principal streets should be much wider than it is necessary to make back or intermediate streets; and the size of the house-steads adjoining main streets should exceed the size of those adjoining back streets.

When practicable, streets should be laid out in straight lines; and if possible on the rectangular plan shown Plate VII., Part V.

Streets are laid out of very different breadths, from 15 to 90 or 100 feet; but when ground is of great value, the breadth of the streets becomes an object of consideration, whether the ground occupied by them be given by the seller, or purchased by the buyer of the adjoining lots.

Building-ground may sometimes be very elegantly laid out in a square or a rectangle. When this is the case, the houses are built on the margin or outside of the square; and in the middle is left an open area, which is generally ornamented with grass-plots, gravel-walks, trees, &c.

If the ground will admit, it is very desirable for each house to have a garden laid out in the front; which must, of course, be sold with the house-stead. The open area may be divided into as many equal parts as there are house-steads in the square; one part may be sold with each house-stead; and the respective purchasers may occupy the whole as joint property.

Ground laid out in this manner generally fetches a good price, as most persons think it more pleasant and healthful living in squares than in streets.

After everything has been properly and judiciously arranged upon the plan, such dimensions must be taken by the scale as will enable the surveyor to stake out all the streets, squares, lots, house-steads, &c., in the field. This being done, the ground may then be considered as ready for inspection and sale.

**NOTE 1.** House-steads must be laid out of different sizes, according to the respectability of the intended buildings.

2. A plan of ground or buildings, intended for sale, is generally left for inspection at the office of the surveyor or solicitor employed on the occasion, from the time of advertising to the time of sale. Also, the special conditions of the sale, not specified in the advertisement, may commonly be known at those offices, or by applying to the proprietor, or to his agent, previously to the day of sale.

3. Building-ground is generally sold by auction; and if it be divided into small lots, it will tend much to promote the sale, as many persons may be desirous of purchasing a single house-stead, who would not find it convenient to purchase a lot containing two or three house-steads.

4. The price of building-ground varies from sixpence to upwards of two guineas per square yard, according to the eligibility of the situation.

5. The method of laying out building-ground so as to form straight streets at right angles to each other is exemplified in the Plan of a new Town, Plate VII.

## SECTION III.

MISCELLANEOUS QUESTIONS RELATING TO SURVEYING, LAYING OUT,  
PARTING OFF, AND DIVIDING LAND.

1. The base of the largest Egyptian pyramid is a square whose side is 693 feet ; how many acres of ground does it cover ?

*Ans. 11a. 0r. 4p.*

2. Required the side of a square garden that cost 3*l.* 18*s.* 1½*d.* trenching, at 1½*d.* per square yard.

*Ans. 25 yards.*

3. Required the area of a rectangle whose length is 1275 and breadth 675 links.

*Ans. 8a. 2r. 17p.*

4. The area of a rectangular field is 14*a.* 2*r.* 11*p.* ; what is its length, its breadth being 925 links ?

*Ans. 1575 links.*

5. A rectangular allotment upon a common cost 78*l.* 1*s.* 10½*d.* digging and levelling, at 7*l.* 10*s.* per acre ; what will be the expense of fencing it half round, at 5*s.* 6*d.* per rood ; its length being 1225 links.

*Ans. 17*l.* 18*s.* 8*d.**

6. Measuring along the base of a field in the form of a rhomboid, I found the perpendicular to rise at 678, and its length 1264 links ; the remainder of the base measured 2435 links ; what is the area of the field ?

*Ans. 39a. 1r. 15½p.*

7. A grass-plot, in a gentleman's pleasure-ground, cost 3*l.* 14*s.* 1*d.* making, at 4*d.* per square yard ; what is the length of the base, the perpendicular being 40 feet, and the figure a rhombus ?

*Ans. 50 feet.*

8. What is the area of a triangular field, the base of which measures 3568 links, the perpendicular 1589 links, and the distance between one end of the base and the place of the perpendicular 1495 links ?

*Ans. 28a. 1r. 15½p.*

9. After measuring along the base of a triangle 895 links, I found the place of the perpendicular and the perpendicular itself = 994 links ; the whole base measured 1958 links ; what is the area of the triangle ?

*Ans. 9a. 2r. 37p.*

10. The area of a triangle is 6 acres, 2 roods, and 8 perches, and its perpendicular measures 826 links ; what will be the expense of making a ditch the whole length of its base, at 2*s.* 6*d.* per rood ?

*Ans. 6*l.* 4*s.* 7¼*d.**

11. What is the area of a triangle whose 3 sides measure 15, 20, and 25 chains respectively ?

*Ans.* 15 acres.

12. Required the area of a grass-plot in the form of an equilateral triangle, whose side is 36 feet ?

*Ans.* 561·18446 feet.

13. What is the area of a triangular field whose 3 sides measure 2564, 2345, and 2139 links ?

*Ans.* 23a. 2r. 0½p.

14. The three sides of a triangular fish-pond measure 293, 239, and 185 yards ; what did the ground which it occupies cost, at 185*l.* per acre ?

*Ans.* 843*l.* 7s. 8d.

15. How many square yards of paving are there in a trapezium whose diagonal is found to measure 126 feet 3 inches, and perpendiculars 58 feet 6 inches and 65 feet 9 inches ?

*Ans.* 871·47569 yards.

16. In taking the dimensions of a trapezium, I found the first perpendicular to rise at 568, and to measure 835 links ; the second at 1865, and to measure 915 links ; the whole diagonal measured 2543 links ; what is the area of the trapezium ?

*Ans.* 22a. 1r. 0p.

17. Lay down a trapezium, and find its area from the following dimensions ; namely, the side AB measures 345, BC 156, CD 323, DA 192, and the diagonal AC 438 feet.

*Ans.* 52330·33406 feet.

18. What is the area of a trapezoid whose parallel sides measure 25 and 18 feet ; and the perpendicular distance between them, 38 feet ?

*Ans.* 1197 feet.

19. The parallel sides of a piece of ground measure 856 and 684 links, and their perpendicular distance 985 links ; what is its area ?

*Ans.* 7a. 2r. 13½p.

20. If the parallel sides of a garden be 65 feet 6 inches and 49 feet 3 inches, and their perpendicular distance 56 feet 9 inches ; what did it cost at 325*l.* 10s. per acre ?

*Ans.* 24*l.* 6s. 7½d.

21. It is required to lay down a pentangular field, and find its annual value at 2*l.* 5s. per acre, the first side measuring 926, the second 536, the third 835, the fourth 628, and the fifth 587 links ; and the diagonal from the first angle to the third 1194, and that from the third to the fifth 1223 links ?

*Ans.* 18*l.* 10s. 7½d.

22. The diameters of an elliptical piece of ground are 330 and 220 feet ; and how many quicks will plant the fence forming the circumference, supposing them to be set 5 inches asunder ?

*Ans.* 2073.

23. Given the lengths of 7 equidistant ordinates of an irregular

piece of ground, as follows ; 15, 19, 20, 23, 25, 30, and 33 feet ; and the length of the base 72 feet ; required the plan and area.

*Ans.* 1704 feet.

24. What must be the length of a chord which will strike the circumference of a circular plantation that shall contain just an acre and a half of ground ?

*Ans.* 48·072 yards.

25. The annual rent of a triangular field is 43*l.* 15*s.*, its base measures 25, and perpendicular 14 chains ; what is it let for per acre ?

*Ans.* 2*l.* 10*s.*

26. The transverse diameter of the ellipse in Grosvenor-square measures 840 links, and the conjugate 612, within the wall ; the wall is 14 inches thick ; what quantity of ground does it inclose, and how much does it occupy ?

*Ans.* the wall incloses 4*a.* 0*r.* 6*p.*, and occupies 1760·531 square feet.

27. Two sides of an obtuse-angled triangle are 5 and 10 chains ; what must be the length of the third side that the triangle may contain just two acres of ground ?

*Ans.* 8·06225 or 13·60147 chains.

28. What is the area of an isosceles triangle inscribed in a circle whose diameter is 24 ; the angle included by the equal sides of the triangle being 30 degrees ?

*Ans.* 134·3538.

29. The side AB of a triangular field is 40, BC 30, and CA 25 chains ; required the sides of a triangle parted off by a division-fence made parallel to AB, and proceeding from a point in CA at the distance of 9 chains from the angle A.

*Ans.* 16, 19·2, and 25·6 chains.

30. A field in the form of a right-angled triangle is to be divided between two persons, by a fence made from the right angle, meeting the hypotenuse perpendicularly, at the distance of 880 links from one end ; required the area of each person's share, the length of the division-fence being 660 links ?

*Ans.* 2*a.* 3*r.* 24½*p.* and 1*a.* 2*r.* 21½*p.*

31. It is required to part from a triangular field whose 3 sides measure 1200, 1000, and 800 links respectively, 1 acre, 2 roods, and 16 perches, by a line parallel to the longest side.

*Ans.* The sides of the remaining triangle are 927, 772½, and 618 links respectively.

32. The base of a field, in the form of a trapezoid, is 30, and the two perpendiculars are 28 and 16 chains respectively ; it is required to divide it equally between two persons, by a fence parallel to the perpendiculars.

*Ans.* The division fence is 22·8035 chains, and it divides the base into two parts, whose lengths are 17·0087 and 12·9913 chains respectively.

33. A gentleman a garden had,  
 Five score feet long and four score broad ;  
 A walk of equal width half round  
 He made, that took up half the ground ;  
 Ye skilful in geometry,  
 Tell us how wide the walk must be.

*Ans. 25·96876 feet.*

NOTE 1. If the sum of the two diameters of an ellipse be multiplied by 1·5708, the product will be the circumference, exact enough for most practical purposes. (See Question 22.)

2. All the foregoing questions are taken from the author's Treatise on Practical Mensuration; consequently, their solutions may be found in the Key to that work.

## PART VIII.

### PLANE TRIGONOMETRY.

PLANE TRIGONOMETRY teaches how to determine certain unknown parts of a triangle from having the other parts given. The method of resolution and solution is based upon the relation, that exists between the sides and angles of triangles. Thus, in the right-angled triangle ABE (fig. 1), if the sides AB and AE, together with the included angle EAB, are given, the side subtending the given angle and the angles adjacent to it may then be found.

### SECTION I.

#### DEFINITIONS.

1. The circumference HBKE of a circle is divided into  $360^\circ$ , each degree into  $60'$ , and each minute into  $60''$ .

2. An arc is a part of the circumference lying between two radii, and is the measure of the angle which the latter form at the centre. Thus AB is the measure of the angle ACB (by construction =  $60^\circ$ ).

3. When the two diameters HK and EB divide the circle into four equal parts, HCB, BCK, KCE, and ECH, they are termed quadrants of the circle.

4. A right angle is a quadrant, and contains  $90^\circ$ .

5. The complement of an arc is what it wants of  $90^\circ$ . Thus AH and AB are the complements of each other.

6. The supplement of an arc is what it wants of  $180^\circ$ . Thus  $AB$  and  $AE$  are the supplements of each other.

7. The sine  $AS$  of the arc  $AB$  that measures an acute angle  $ACB$  is a right line drawn from the extremity  $A$  of the radius  $CA$  perpendicular to the radius  $CB$  that bounds the other extremity of the arc at  $B$ , and is parallel to  $BD$ .

Fig. 1.

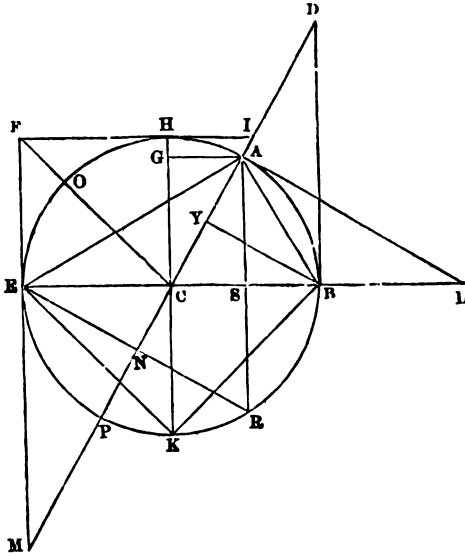

8. The cosine of an arc that measures an acute angle is the sine of its complement. Thus  $AG$  is the cosine of  $AB$ , and  $AS$  the cosine of  $HA$ .

9. The versed sine of an arc that measures an acute angle is that segment of the radius which lies between the sine and the arc. Thus  $SB$  is the versed sine of  $AB$ , and  $GH$  the versed sine of  $HA$ .

10. The covered sine of an arc is the versed sine of its complement. Thus  $GH$  is the covered sine of  $AB$ , and  $SB$  the covered sine of  $HA$ .

11. The sine  $EN$  of the arc  $AE$  that measures an obtuse angle  $ACE$ , is a right line drawn from the extremity  $E$  of the radius  $CE$  perpendicular to the opposite radius  $AC$  produced to  $N$ , and is parallel to the tangent  $AL$  from the other extremity of the arc at  $A$ .

12. The tangent  $BD$  of the arc  $AB$  that measures the acute angle  $ACB$  is a perpendicular drawn from the extremity  $B$  of the radius  $CB$  that meets the other radius  $CA$  produced to  $D$ .

13. The cotangent of an arc that measures an acute angle is the



tangent of its complement. Thus HI is the cotangent of AB, and BD the cotangent of HA.

14. The tangent AL of the arc AE, which measures the obtuse angle ACE, is a perpendicular drawn from the extremity A of the radius CA, that meets the other radius EC produced to L, and that is parallel to the sine EN, drawn from the opposite extremity of the arc.

15. The secant CD of the arc AB that measures an acute angle, as ACB, is the radius AC produced to D that limits the tangent BD, drawn perpendicularly from the extremity of the other radius at B.

16. The cosecant of an arc is the secant of its complement. Thus CI is the cosecant of AB, and CD the cosecant of HA.

17. The secant CL of the arc AE that measures an obtuse angle, as ACE, is that portion of the right line EL consisting of EC produced to L, that lies between the centre C and the extremity L of the tangent AL, that makes with AC, the other radius, an angle equal to its supplement, and with AC produced an angle LCM = ACE.

18. The versed sine ES of the arc AE that measures the obtuse angle ACE is that portion of the diameter EB that lies between the sine AS and the other extremity of the arc at E.

*Corollaries from the above definitions and diagram.*

1. The sine of an arc is equal to half the chord of double that arc,  $AS = \frac{1}{2}AR$ .

2. The sine AS of  $60^\circ$  bisects the radius CB in S,  $CS = SB$ .

3. The sine of  $90^\circ =$  radius.

4. The cosine of  $60^\circ =$  its versed sine,  $AG = SB$ .

5. The chord of  $60^\circ$  and the tangent of  $45^\circ$  are each equal to radius,  $AB = AC = HF$ .

6. The sine, tangent, and secant of  $45^\circ$  are respectively equal to the cosine, cotangent, and cosecant of  $45^\circ$ .

7. The tangent of  $60^\circ$  is equal to the chord of  $120^\circ$ ,  $BD = AR$ .

8. The secant of  $60^\circ =$  diameter,  $CD = EB$ .

9. The secant of  $45^\circ$  bisects the chord of  $90^\circ$ , and is equal to it,  $CF = EK$ .

10. The square of the diameter is equal to twice the square of the chord of  $90^\circ$  or secant of  $45^\circ$ ,  $EB^2 = EK^2 + BK^2$ .

11. The square of the diameter is equal to the square of the chord of  $120^\circ$  added to the square of the radius,  $EB^2 = AR^2 + AB^2$ .

12. The square of the chord of  $90^\circ$  is equal to twice the square of the radius,  $CF^2 = CH^2 + HF^2$ .

13. The sum of the three angles of a triangle is equal to  $180^\circ$ .

14. If one of the acute angles of a right-angled triangle be given, the other acute angle is its complement, so that all the angles are

given. And if any two angles of a triangle =  $90^\circ$ , then the remaining angle =  $90^\circ$ , and the triangle is right-angled.

15. If one of the angles of an oblique-angled triangle be given, then that angle subtracted from  $180^\circ$  gives the sum of the other two angles; and if two angles are given, their sum subtracted from  $180^\circ$  gives the remaining angle.

16. If one of the equal angles of an isosceles triangle be found, then the other two angles are determined, because the sum of the two equal angles adjacent to the base subtracted from  $180^\circ$  gives the remaining angle at the vertex. And if the two angles at the base are equal, the sides that subtend them are equal, and the triangle is isosceles.

17. The two acute-angled triangles ABC and AER are each equilateral and equiangular, and therefore similar to each other, and each angle is  $60^\circ$ .

18. The three right-angled triangles ASB, ASC, and CGA are similar and equal to each other; ANE = ESA; also DBC = LAC = MEC.

19. A triangle standing upon the chord of an arc with two sides radii is isosceles.

20. In the resolution of a right-angled triangle, as CAL, if C is taken for the centre of the circle, and CA for radius, then AL is tangent and CL secant. If L is taken for the centre of the circle, and LA for radius, then AC is tangent, and LC secant. And if L is taken for the centre, and LC for radius, then CA will be sine and AL = cosine.

21. To every arc measuring either an acute or obtuse angle two sines, two tangents, and two secants can, and often require to be drawn.

22. In an arc subtending an acute angle the two sines and two tangents cross each other within the angle, so that the centre of the circle and the two points of intersection, the one where the two sines cross, and the other where the two tangents cross, are in a right line that bisects the arc, its chord, and the angle it measures.

23. Each of the two radii, which includes an acute angle at the centre, forms a portion of the two secants to an arc; and when the angle is  $60^\circ$  the portion of each that is inside the arc is equal to the remaining part outside the arc. Thus  $CB = BL$ , so that the tangent AL of  $60^\circ$  diverges from the arc AB, a distance equal to radius.

24. In an arc subtending an obtuse angle the two sines from its opposite extremities fall without the arc perpendicularly upon the two secants, now portions of other radii than those which include the angle. The two tangents are limited by the two secants, ranging from the centre at an angle equal to the supplement of the arc, and

in the opposite direction of the two radii that include the arc or angle. The secant therefore contains no part of the radii that include the angle, but the whole right line formed by each radius and its secant together is greater than the secant of its supplement by radius. Thus  $EL = CL + EC$ .

25. In arcs subtending obtuse angles the parallelism of sines with tangents, and *vice versa*, lies on the opposite sides of the centre, the tangent being on one side, and its parallel sine on the other. Thus  $AS$  is parallel to  $EM$ , and  $EN$  to  $AL$ .

26. In arcs subtending acute angles the parallelism of the sines and tangents of an arc lies within the angle upon the same side of the centre. Thus  $AS$  is parallel to  $BD$ , and  $BV$  to  $AL$ .

27. The sines, tangents and secants of an arc are equal in magnitude or length to the sines, tangents, and secants of the supplement of that arc; but their position is different, so that a sine, tangent, or secant of the one cannot properly be termed the sine, tangent, or secant of the other, while the versed sine of an obtuse angle is greater than the versed sine of its supplement.

28. It is the direction and position of the two sides of a triangle that determine the measure of the angle they include, and *vice versa* the measure of the angle they include that fixes the position of any two sides.

29. When a right line is drawn from the obtuse angle of an oblique-angled triangle, perpendicular to the base or side subtending the obtuse angle, it resolves the oblique-angled triangle into two right-angled triangles; the perpendicular thus drawn becomes the sine to each of the two angles adjacent to the base; the sides that include the obtuse angle are radii; and the segments of the base are each equal to the cosine of its respective adjacent angle. Thus in the obtuse triangle  $EAL$ ,  $AS$  is sine to  $E$  and  $L$ ,  $ES = \cos. E$ , and  $LS = \cos. L$ , and  $ASE$  and  $ASL$  are each right-angled triangles.

NOTE 1. The sine, tangent, and secant of an arc, are in some books defined to be the sine, tangent, and secant of the supplement of that arc. This, however, is not correct: the two arcs measure two angles of a different species, the one being acute and the other obtuse, according to their geometrical definitions (see Def. 12, 13, 15, 18, 19, 20, 22, 23, and 24, Part I.); consequently each has a separate and independent existence distinct from the other. Thus  $BD$ , although defined to be the tangent of  $AE$  is not its tangent; neither is  $EM$  the tangent of  $AB$ . Again  $BV$  is not the sine of  $AE$ , nor  $EN$  the sine of  $AB$ ; much less is  $ES$  the versed sine of  $AE$ , viz.  $ES$  also the versed sine of  $AB$ ; and lastly  $CD$  is not the secant of  $AE$ , nor  $CM$  the secant of  $AB$ . Hence the conclusion of dissimilarity as to position (cor. 27).

2. The diagram is drawn purposely to illustrate the dissimilarity of position that exists between the sines, tangents, secants, and versed sines of angles and their

supplements, and also to show some of the properties of triangles formed by lines in and about the circle that are of daily use in taking bearings and tie lines in surveying. It may also be added here that figs. 2 and 3 of the next section will still further show how absolutely necessary it is to attend to such distinctive characteristics as the position of lines, and the species of angles they subtend, in order to secure accuracy in the trigonometrical resolution of the triangles into which a survey may be divided, and to avoid ambiguity and error in plotting the same.

## SECTION II.

## ON SPECIES, CONSTRUCTION, RATIOS, RESOLUTION, AND SOLUTION, OF TRIANGLES.

1. Under Geometry, Part I., six kinds of plane triangles are defined, viz., (1) right-angled; (2) equilateral; (3) isosceles; (4) scalene; (5) acute-angled; and (6) obtuse-angled.

2. The angles of triangles are divided into three kinds, and defined (1) right angles; (2) acute angles; and (3) obtuse angles.

3. A plane triangle consists of six parts, viz., three sides and three angles; and if three of these, including one side, are given, the others, technically termed the sought parts, may be ascertained from the ratio or relation that subsists between them and the given parts.

4. In Plane Trigonometry triangles are divided into two classes, right-angled triangles and oblique-angled triangles. (The latter thus includes the five species of triangles that are not right-angled.)

5. In a trigonometrical survey the ground is divided into triangles. Thus any three station-poles not in a right line form a plane triangle.

6. Fields, farms, and estates may be divided and measured with the chain, either on the triangular method, as illustrated Plate III. Part V., or on the parallel method (Plate IV. Part V.), and yet both may be surveyed by the theodolite as if divided into triangles independently of those of the former survey. Thus the survey (Plate III.) is divided into two large triangles  $+1 + 8 + 10$ , and  $+ 1 + 8 + 15$ ; or into four triangles  $+ 1 + 5 + 10$ ,  $+ 5 + 10 + 8$ ,  $+ 8 + 5 + 15$ , and  $+ 15 + 5 + 1$ . Again the estate (Plate IV.) may be divided into two triangles  $+ 1 + 6 + 32$ , and  $+ 1 + 32 + 40$ . Or the same station-poles shown on the plan may be used in taking the bearings, so as to give a much larger number of triangles in the trigonometrical survey. Thus each of the quadrilateral areas may be taken as forming two triangles.

7. In large surveys, where each of the interior triangles is bounded

by other three triangles, if the sides of one are determined, that will give one side in each of the adjacent triangles.

8. In trigonometrical surveying a side of one of the triangles is measured with the chain. This is termed the *main-line* or *base-line*. The other two sides may then be determined from the relation they bear to it (the measured line), and to the angles they subtend; and as a side of each of the adjacent triangles is thus found (by last article, 7), the sides of all the other triangles in the survey may therefore be ascertained from trigonometrical data.

9. The first triangle surveyed and plotted is the one that contains the base-line; and as this side is measured with the chain and the two adjacent angles with the theodolite, such data will give the other angle and species of triangle either by cor. 14, 15, or 16, Sect. I.

#### *Right-angled triangles.*

10. The field-book of the trigonometrical survey supplies only part of the dimensions requisite for plotting. Technically these are termed the "bearings," or "the given sides and angles," so that the remaining parts are found by calculation, or construction, or both, as illustrated in the following four examples.

Ex. 1. Let the base line be EB in the triangle AEB (fig. 1): let B =  $60^\circ$  and E  $30^\circ$ , then (by cor. 14) the triangle is right-angled and scalene. The side EB and angles B and E are given to find BA and EA: A is found by cor. 14.

Ex. 2. If the angles at the base are each  $45^\circ$  then EKB would represent the triangle; and as the angles E and B are equal, so are the sides BK and EK. The triangle is therefore both isosceles and right-angled, with a side and three angles given to find the remaining two sides.

Ex. 3. If one of the angles at the base is a right angle, then ASE would represent the triangle; ES the base line measured with the chain; E and S the angles taken with the theodolite; EA and SA the sides sought, and A the remaining angle, determined by cor. 14. Sect. I.

Ex. 4. In the interior triangles of a survey the two sides ES and SA, or EA and AS, or EA and ES, and the angle A =  $90^\circ$  may be found, when the remaining side EA and two acute angles E and A adjacent will be the parts sought: or ES and the angles E and A; or AS and the angles E and A, as the case may be.

11. The large triangles on the plans Part V. Plates III. and IV. may be considered copies of those in the field, so that plotting the first two bearings is simply a work of copying (Problems XIX. XX. and

XXI. Part I.), and when the two bearings or angles at the base are given the first triangle may be formed (cor. 28). Thus draw the base line EB; next EA indefinite, making  $E = 30^\circ$  (Problem XX. Part I.); BA in the same manner, making  $B = 60^\circ$ : the two indefinite lines will, if the work is correctly performed, intersect each other at A, and form the triangle EAB right-angled at A. The lines EA and BA may then be measured by the scale on which EB has been laid down upon the plan, or they may be found by trigonometry. Thus, if EB is radius, as] in the first two examples, then BA would be sine and EA cosine. The ratio would therefore in these two examples be that of radius to the sine and cosine of the angle  $E = 30^\circ$ . In the *third example* ES is radius, SA tangent, and EA secant, consequently the ratio is that of radius to the tangent and secant of  $E = 30^\circ$ . In the former case, either of the sides about the right angle may be sine or cosine; *i.e.*, if the one is sine the other is cosine, and in the latter, either side about the right angle may be radius or tangent; *i.e.*, if the one is radius the other is tangent.

12. The trigonometrical solution of the four examples would therefore be effected by the following formulas:—

Ex. 1.	To find BA	formula 1	Rad. : sin. E :: EB : BA
„	To find EA	„ 2	Rad. : cos. E :: EB : EA
Ex. 2.	To find BK	„ 3	Rad. : sin. E :: EB : BK
„	To find EK	„ 4	Rad. : sin. B :: BE : EK = BK
Ex. 3.	To find EA	„ 5	Rad. : sec. E :: ES : EA
„	To find SA	„ 6	Rad. : tan. E :: ES : SA
Ex. 4.	To find EA	„ 7	Rad. : sec. E :: ES : EA
„	To find E	„ 8	ES : SA :: rad. : tan. E
„	To find ES	„ 9	Rad. : cos. E :: EA : ES
„	To find E	„ 10	EA : AS :: rad. : sin. E
„	To find SE	„ 11	sec. A : tan. A :: EA : SE
„	To find A	„ 12	AS : SE :: rad. : tan. A

NOTE.—Under right-angled triangles it is common to consider the right angle as understood to be one of the parts given, although not so expressed. This however, is objectionable, for when articulated pupils enter the field with such formulas stereotyped as it were upon their memories they are worse than useless to them, as they frequently lead to much confusion. In taking the bearings, right angles have to be found in the same way as acute and obtuse ones; and it may be further observed that unless the two acute angles =  $90^\circ$  as a *proof check*, right-angled triangles are treated as oblique ones; and as a general rule this is the more advisable one to follow in the trigonometrical survey. Thus the right-angled triangle EAB (Fig. 1) is resolved into two right-angled triangles by drawing the perpendicular AS.

*Oblique-angled triangles.*

13. When three parts of an oblique-angled triangle are given to find the remaining parts, it requires to be resolved into two or more right-angled triangles. This is done by drawing perpendiculars from the angles to the sides that subtend them (by cor. 29), or to the sides that subtend them produced. Thus AS (fig. 1) resolves the three triangles EAB (right-angled), EAL (isosceles), and CAB (equilateral) each into two right-angled triangles.

Ex. 1. If the angles at the base are each  $60^\circ$  then the remaining angle is  $60^\circ$  and the sides opposite the given angles each equal to the base (cor. 17). In this case resolution is unnecessary.

Ex. 2. If the angles at the base are equal, but greater or less than  $60^\circ$ , then the triangle is isosceles, and a perpendicular from the vertex to the base will resolve it into two equal right-angled triangles. In this case half the base may be taken for radius, when the side opposite the right angle would be secant of the given angle. Thus let EAL (fig. 1) be the triangle, EL the base; E and L each  $30^\circ$ ; then ES would be radius, and EA found by formula 5 under article 12; AL and A by cor. 16.

Ex. 3. If the angles at the base are acute and unequal, the one being  $45^\circ$  and the other  $60^\circ$ , then the remaining angle opposite the base or given side is  $75^\circ$  and the triangle acute and scalene.

Let ABC (fig 2) be the triangle, AB the base, A and B the angles

FIG. 2.

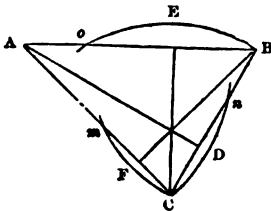

taken with the theodolite, AC and BC the sides sought, C being found by cor. 15. Draw the perpendiculars AD, BF, and CE, which resolve AB into six right-angled triangles.

In the solution of this example each of the angles A, B, and C is common to two right-angled triangles; their complements therefore are equal, or the remaining acute angle of each of the two triangles is equal each to each, so that the triangles are similar, each perpendicular being the sine of the two angles adjacent to the two segments of the base. The sides opposite the equal angles are thus proportional, and the ratio is that of a greater to a less magnitude, the given side being the greatest, or the given side being the radius of the greatest of the three circles now involved. *The sides therefore are to one another as the sines of the angles opposite.* Thus  $AB : AC :: \sin. C : \sin. B$ . To find AC, therefore, we have  $\sin. C : \text{rad.} :: AD : AC$ ;  $\sin. B : \text{rad.} :: AD : AB$ . Then inversely  $\text{rad.} : \sin. B :: AB : AD$ ; and by *ex æquo* inversely  $\sin. C : \sin. B :: AB : AC$ . Again, to find CB we have C the centre

with CB radius, and BF sine; and A the centre with AB as radius, and BF sin. Then  $\sin. C : \text{rad.} :: BF : CB$ ;  $\sin. A : \text{rad.} :: BF : AB$ ; by inversely  $\text{rad.} : \sin. A :: AB : BF$ ; and by *ex æquo* inversely  $\sin. C : \sin. A :: AB : CB$ .

Ex. 4. If the angles adjacent to the base-line are unequal and their sine less than  $90^\circ$ , then the triangle is obtuse-angled and scalene, the obtuse angle being opposite the base.

Let ABC (fig. 3) be the triangle, AB the base line, A and B the angles adjacent whose sum is  $60^\circ$ ;  $C = 120^\circ$  (by cor. 15). Draw the perpendiculars, AD on BC produced, BF on AC produced, and CE on AB, the base. In this case because AC and BC are each less than AB, the sines AD and BF of the angles A and B when AB is radius, falls without the triangle; and because C is obtuse AD is the

Fig. 3.

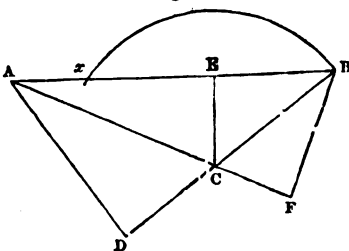

sine of  $C = 120^\circ$ , when CA is radius; and BF the sine of  $C = 120^\circ$  when CB is radius. But when A and B are the centres, and AC and BC the radii, then CE is the common sine; and the segments of the base the cosines of A and B. The sides AC and BC may thus be obtained by several methods of solution. Thus  $AB : AC :: \sin. C : \sin. B$ . Or  $\text{rad.} : \sin. B :: BA : AD$ ; and as the angle ACD is equal to  $BCF = 60^\circ$ , then by making AD radius,  $\text{rad.} : \sec. A :: AD : AC$ . BF and BC may be found in a similar manner. The area of the triangle ABC is obtained from CE as sine to A and B, AC and BC being respectively the two radii.

Ex. 5. If one of the angles at the base is obtuse, say  $120^\circ$ , and the other less than  $30^\circ$ , so that the acute angles found by cor. 15 are unequal, then the triangle is obtuse and scalene, as in Example 4, the greater side being opposite the greater angle, and the less one opposite the less angle.

Let ABC (fig. 3) be the triangle, AC the base line, A and C the given angles, then B is also given (cor. 15). Draw the perpendicular CE, which will give the trigonometrical data for finding the segments AE and EB of the base AB, and also BC. Thus by making AC radius, CE is sine and AE cosine; CE may therefore be found by formula 1, art. 12, and AE by formula 2. Again, by making BE radius, EC would be tangent, and BC secant of the angle B, so that by formulas 6 and 11 conversely BE and BC would be found. Thus  $\tan. B : \text{rad.} :: EC : BE$ ; and  $\tan. B : \sec. B :: EC : BC$ .  $AE + EB = AB$ . The two sides AB and BC may also be found as by Examples 3 and 4.



Ex. 6. If one of the angles at the base is obtuse, and the other the greatest of the two acute angles, as B (fig. 3), then BC would be the base line. The solution would be the same as in the last case (5), but as BC is the less side, the ratio is now that of a less magnitude to a greater.

14. The preceding examples have reference to the triangle on the base line, when that side only and the adjacent angles, and hence by cor. 15 all the angles, are given. More frequently in practice the three sides of the first triangle are carefully measured with the chain before the trigonometrical survey begins. This is done purposely that the one survey may be a proof check on the accuracy of the other.

15. In the other and interior triangles the parts found by previous cases (articles 7 and 8) are more diversified. Thus two sides and an angle opposite one of them may be found from two previous cases, or two sides and the angle they include, or two sides and two angles (*i.e.*, all the angles, cor. 15), and in some central and exceptional cases the three sides only.

16. In examples of this kind the construction, resolution, and solution, are more simple, provided the species and ratios are properly attended to in the trigonometrical survey.

Ex. 7. Given the two lesser sides and the angle opposite the least of them, to find the other side and two angles of an acute-angled scalene triangle.

Let ABC (fig. 2) be the triangle, AC and BC the given sides, A the angle =  $45^\circ$ . Then AB is the side sought, and C and B the angles. Draw CE and BF, which resolve the triangle into four right-angled triangles. In this case the triangle is scalene and acute-angled, and the ratio that of a less magnitude to a greater, because the lesser of the two given sides is opposite the given and smallest angle. The solution would therefore be to find B,  $BC : CA :: \sin. A : \sin. B$ , which also gives C (by cor. 15). Then  $\sin. A : \sin. C :: BC : BA$ .

Ex. 8. Given the two lesser sides and the angle opposite the greatest of them, to find the other side, and two angles of an acute-angled scalene triangle.

Let ABC (fig. 2) be the triangle, BC and AC the given sides, B the angle =  $60^\circ$ . Then AB is the side sought, and A and c the angles (any one of which will determine the other by cor. 15). Draw CE and BF, which resolve the triangle into four right-angled triangles. In this case the species and ratio are similar to those of the last example (7), as also the resolution. The construction and solution are also the same in principle, the only difference being that the greatest of the two given sides, instead of the less, is the last line in the con-

struction ; the following formula will give the angles sought ; as  
 $CA : BC :: \sin. B : \sin. A.$

Ex. 9. Given the two greater sides, and the angle opposite the greatest of them, to find the other side and two angles of an acute-angled scalene triangle.

Ex. 10. Given the greatest and least side, and the angle opposite the latter, to find the remaining side and angles of an acute-angled scalene triangle.

In both these examples, ABC (fig. 2) may represent the triangle, so that the species, construction, resolution, and solution are similar, but the ratio is from a greater to a less magnitude.

Ex. 11. Given the sides about the obtuse angle, and the less of the two acute angles, to find the other side and two angles of an obtuse-angled scalene triangle.

Let AC and BC be the two sides, and A the angle given of the triangle ABC (fig. 3). Then AB is the side sought, and B and C the angles. Draw CE, which gives two right-angled triangles, AEC and BEC.

In this example the sides AC and BC are by hypothesis already drawn upon the plan, and their extents or lengths known, as also the bearing of AB from C, which determines the direction and position of AB, B and C (cor. 28). But before AB is drawn, its length, and also the angles C and B, require to be found, as a check upon accuracy, the bearings having to be corrected for obliquity and refraction. Hence the object of the solution. To find CD, rad. :  $\sin. A :: AC : CE$ ; rad. :  $\cos. A :: AC : AE$ . To find B,  $BC : CE :: \text{rad.} : \sin. B$ ; rad. :  $\cos. B :: BC : BF$ ;  $AE \times EB = AB$ ;  $180^\circ - A + B = C$  (cor. 15).

Ex. 12. Given the two greater sides, and the angle opposite the lesser of them, to find the other side, and two angles of an obtuse-angled scalene triangle.

Ex. 13. Given the greatest and least side, and the obtuse angle, to find the other side and angles of an obtuse-angled scalene triangle.

In both these cases ABC (fig. 3) may represent the triangle. In the former case, CE will resolve the triangle, as in Example 11, but in the latter (13), BF or AD is requisite, as in previous resolutions, Ex. 4, 5, and 6. The two solutions would therefore be accordingly, the ratios being from a greater to a less magnitude.

Ex. 14. Given the two greater sides, and the angle they include, to find the other side and two angles of an acute-angled scalene triangle.

Let AB and AC (fig. 2) be the two given sides, and A the angle of the triangle ABC ; then BC and the adjacent angles B and C are the parts sought.

In this case, and in all examples of this kind, the given angle determines the position of the given sides that include it (by cor. 28), so that the construction and plotting is simple, and the parts sought easily measured by the scale and protractor.

The ratio for the trigonometrical solution is equally definite. Thus, as the given sides are opposite the unknown angles, and the unknown sides opposite the given angle, it follows that  $C$  must be greater than  $B$ , and  $BC$  less than  $AC$ , the least of the two given sides. The ratio, therefore, is that of a greater to a less magnitude.

Again, as  $180^\circ - A = B + C$ , it follows that half the sum of the unknown angles is given. Now as half their difference added to half their sum gives the greater ( $C$ ), and as half their difference taken from half their sum gives the less ( $B$ ), it is usual to find half the difference. Thus :—

$$AB + AC : AB - AC :: \tan. \frac{1}{2} (C + B) : \tan. \frac{1}{2} (C - B).$$

The angles, however, may be otherwise found by resolving the triangle as in fig. 2. Then  $C$  is common to two right-angled triangles  $ADC$  and  $BFC$ , and  $B$  to other two. Either, therefore, can be determined in the process of finding  $BC$ . Thus, if  $AC$  is radius and  $A$  the centre, then  $CE$  is  $\sin. A$ , and  $AE$   $\cos. A$ ; consequently, as  $AB$  is given,  $AB - \cos. A = EB$ . To find  $B$ , make  $BE$  radius and  $EC$  tangent. The formula for solution would then be  $BE : EC :: \tan. B$ ; and to find  $BC$ ,  $\text{rad.} : \sec. B :: BE : BC$ ;  $180^\circ - A + B = C$  (cor. 15).

*Exercise 1.* Given  $AC$  and  $CB$ , and the included angle  $C$  (fig. 2); required the formulas for finding  $AB$ , and the angles  $A$  and  $B$ .

2. Given  $CB$  and  $BA$ , and the included angle  $B$  (fig. 2); required the formulas for finding  $AC$  and the adjacent angles  $A$  and  $C$ .

*Ex. 15.* Given the two greater sides, and the angle they include to find the other side and two angles of an obtuse-angled scalene triangle.

Let  $AB$  and  $AC$  be the two given sides, and  $A$  the angle of the triangle  $ABC$  (fig. 3). Then  $BC$  is the side, and  $B$  and  $C$  the angles sought. Draw  $CE$ . The solution is similar to that of Example 14,  $B$  and  $BC$  being given in this case instead of  $A$  and  $AC$  in the previous one.

*Exercises 1.* Given  $AC$  and  $CB$  and the included angle  $C$  (fig. 3); required the formulas for finding the greater side  $AB$  and the acute angles  $A$  and  $B$ .

2. Given  $CB$  and  $BA$  and the included angle  $B$  (fig. 3); required the formulas for finding  $AC$ ,  $A$  and  $C$ .

*Ex. 16.* Given the three sides to find the angles of a scalene triangle.

Let  $ABC$ , either fig. 2 or 3, be the triangle. From  $c$ , the angle

opposite the greater side, draw the perpendicular  $CE$ . In this example, according to hypothesis, the triangle is constructed by the plotting of the adjacent three triangles, and from the solutions of them the three sides  $AB$ ,  $AC$ , and  $BC$ , were previously found. Such being the case, the perpendicular  $CE$  is drawn purposely for giving the content or area, and its length is easily found by the scale. Very generally this is the practice followed when none of the angles are taken in the field. There are, however, exceptions, for which provision requires to be made, *i.e.*, to find the angle  $A$  or  $B$ , of which  $CE$  is sine,  $AC$  or  $BC$  being radius. In the two right-angled triangles  $AEC$  and  $BEC$ , the right angles at  $E$  and the two sides opposite are given. There is thus only two parts given in each; a part is therefore wanting to effect the solution. This may be found by several propositions, from whence general rules are deduced. One will suffice for an example. Thus, to find the segments of the base  $AE$  and  $EB$  whose sum  $AB$  is given,  $AB : AC + BC :: AC - BC : AE - EB$ . Then half the difference of the segments, added to half their sum, gives the greater  $AE$ , and half their difference taken from half their sum, gives the less  $EB$ . Having thus found  $AE$  and  $EB$ , they are the cosines of  $A$  and  $B$ ,  $AC$  and  $BC$  being the radii. To find  $A$ ,  $AC : AE :: \text{rad.} : \cos. A$ . To find  $B$ ,  $BC : BE :: \text{rad.} : \cos. B$ . To find  $CE$ ,  $\text{rad.} : \sin. A :: AC : CE$ .

17. In the construction of all scalene triangles, whether acute-angled, obtuse-angled, or right-angled, the arcs of the lesser radii that measure the angles they include intersect in two points the lines that unite them with the longer radii. Thus, in the right-angled triangle  $EAB$  (fig. 1), with centre  $A$  and radius  $AB$ , the greater side is intersected in two points  $B$  and  $C$ . In fig. 2,  $AC$ , with centre  $A$ , intersects  $BC$  in  $C$  and  $n$ ;  $BC$ , with centre  $B$ , intersects  $AC$  in  $C$  and  $m$ ;  $CB$ , with centre  $C$ , cuts  $AB$  in  $B$  and  $o$ . And had  $AOC$  been the triangle, then  $oA$  with centre  $o$  would have cut  $AC$  in two points. In the obtuse-angled triangle  $ABC$  (fig. 3),  $CB$ , with centre  $C$ , intersects  $AB$  in  $B$  and  $x$ . And when the base of an isosceles triangle is less than one of the sides, and only one side, the base and vertical angle given, the species of the triangle being unknown, then the base line may cut the unknown side in two points.

30. These examples show that in the construction of triangles, and hence in plotting the bearings of the trigonometrical survey, when two sides of a triangle and one angle only are given, then, either the species of the triangle and ratios of the sides must be known, or else the given angle requires to be the one that is included by the two given sides, so as to determine their position (cor. 28), and hence the position of the other line between their extremities, and of the

adjacent angles thus formed, otherwise the construction will be what has been termed *ambiguous*, *i.e.*, one of two triangles, as pointed out in Euclid's Data, Prop. XLVII., Case 3.

31. If, however, the species of the triangle, and ratios of the sides, and the position of the lesser given radius determined by the given angle (cor. 28) are known, such data will also determine the position of the intersecting radius or side that cuts the indefinite and first side drawn at the proper length. Thus, in fig. 1, because the triangle is right-angled at A, that fixes the direction and position of the lesser radius AB. But had the triangle been in species an obtuse-angled isosceles one, then the position of the lesser side or radius would have been AC, and the triangle ACE. In like manner ABC (fig. 2), being in species an acute-angled scalene triangle, that determines the position of the two lesser radii. But in the obtuse-angled scalene triangle ABC (fig. 3),  $CZA$  is also an obtuse-angled scalene triangle, so that species alone is not enough in this class of triangles, the ratios being also necessary. In other words it is the position of CB, and the relation of the greater side to the other two sides, that determines the construction of the triangle.

32. In plane trigonometry triangles exist, and hence their species and also the ratios of the sides and angles exist. If, therefore, a side and two angles are given, or two sides and an angle, or any three parts including a side (art. 3), then the trigonometrical relation that subsists between them and the unknown parts determines the latter. According to the general definition given of trigonometry it is this relation that supplies the mathematician and surveyor with data for finding the unknown parts. This is consequently the given hypothesis in every proposition in plane trigonometry. The sides and angles sought are therefore as definite and free from ambiguity as those given, otherwise they could not be determined.

33. The ambiguity referred to under (30) is, it will thus be seen (32), exclusively confined to constructive geometry. Applied to land-surveying it is wholly confined to the work of plotting the bearings or copying the triangles of the field on to the plan.

34. In the trigonometrical survey the species and ratios of the triangles should be carefully determined in the field; as this, practically speaking, is the principal part of the work, or the principal function of plane trigonometry. If this is done, no ambiguity will be experienced in plotting the bearings. (See Sect. VI. Part IX.)

## SECTION III.

## PLANE TRIANGLES.

The solution of plane triangles may be reduced to four cases, in which the given parts are the following:—

CASE I. A side and three angles.

CASE II. Two sides and an angle opposite one of them.

CASE III. Two sides and their included angle.

CASE IV. The three sides.

## SOLUTION OF RIGHT-ANGLED PLANE TRIANGLES.

## CASE I.

*Given the angles and hypotenuse or a side, to determine the triangle.*

RULE.—As sine of any angle : side opposite :: sine of any other angle : its opposite side.

1. Given\* the hypotenuse  $AC = 720$  links, and the angle  $A = 53^\circ 8'$ ; to find the sides  $AB$  and  $BC$ , and the angle  $C$ .

*By construction.*

Draw the line  $AB$ , of any length make the angle  $A = 53^\circ 8'$ , draw the hypotenuse  $AC = 720$  links; from  $C$  let fall the perpendicular  $CB$ ; then  $ABC$  is the triangle required: and  $AB$ , being measured, will be found = 432 links, and  $BC = 576$  links; also the angle  $C$  will be found =  $36^\circ 52'$ .

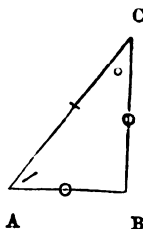

*By calculation.*

The angle  $C = 90^\circ - 53^\circ 8' = 36^\circ 52'$ .

To find $BC$ .	To find $AB$ .
As sine $\angle B = 90^\circ$ 10·00000	As sine $\angle B = 90^\circ$ 10·00000
: hyp. $AC = 720$ links 2·85733	: hyp. $AC = 720$ links 2·85733
:: sine $\angle A = 53^\circ 8'$ 2·90311	:: sine $\angle C = 36^\circ 52'$ 9·77812
12·76044	12·63545
10·00000	10·00000
: side $BC = 576$ links    2·76044	: side $AB = 432$ links    2·63545

NOTE.—The logarithmic operation is performed by adding together the second and third terms of the above proportions, and subtracting the first from the respec-

\* The *given* parts of a triangle are generally marked with a dash (—), and the *required* parts with a circle (o), as in the figures annexed to the constructions.

tive sums, the remainders being the fourth terms : which operations must be understood to be performed in all the following examples, it being unnecessary to put down the work at length as above.

2. The side AB is =4320 links, and the angle A = 53° 8' ; required the other parts.

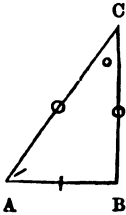

*By construction.*

Make AB = 4320 links, at B erect the indefinite perpendicular BC, make the angle A = 53° 8', and draw AC, meeting BC in C ; then AC will measure 7200 links, BC = 5760 links, and the angle C = 36° 52'.

*By calculation.*

The angle C = 90° - 53° 8' = 36° 52'.

To find AC.

As sin.  $\angle C = 36^\circ 52'$  9.77812  
 : side AB = 4320 links 3.63548  
 :: sin.  $\angle B = 90^\circ$  10.00000  
 : side AC = 7200 links 3.85736

To find BC.

As sin.  $\angle C = 36^\circ 52'$  9.77812  
 : side AB = 4320 links 3.63548  
 :: sin.  $\angle A = 53^\circ 8'$  9.90311  
 : side BC = 5760 links 3.76047

3. In a right-angled triangle are given the hypotenuse = 98 chains and one of the angles = 56° 48', to find the sides and area.

*Ans. Sides 82 and 53.66, area 22ac. Or. 1p.*

4. One side of a right-angled triangle is 2350 links, and its opposite angle 50° ; required the other side and hypotenuse.

*Ans. Side = 1977 links, hyp. = 3067.5 links.*

CASE II.

*Given the hypotenuse, a side, and the right angle, to determine the triangle.*

RULE.—As hypotenuse : radius :: given side : to sine of opposite angle.

1. The hypotenuse AC is 24 chains, and the side AB = 14 chains 40 links ; required the other side and angles.

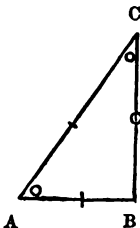

*By construction.*

Make the side AB = 14.40 chains, erect the indefinite perpendicular BC ; with centre A and radius AC = 24 chains, describe an arc cutting BC in C ; join AC ; then BC will be found = 19 chains 20 links, and the angles A and C respectively 53° 8' and 36° 52'.

*By calculation.*

To find the angle C.		To find BC.	
As hyp. AC = 24	1·38021	As sin. $\angle B = 90^\circ$	10·00000
: sin. $\angle B = 90^\circ$	10·00000	: hyp. AC = 24	1·38021
:: side AB = 14·40	1·15836	:: sin. $\angle A = 53^\circ 8'$	9·90311
: sin. $\angle C = 36^\circ 52'$	9·77815	: side BC = 19·20	1·28332

Hence angle  $A = 90^\circ - 36^\circ 52' = 53^\circ 8'$ .

NOTE.—The side BC may be found by Euc. I. 47, thus,

$\sqrt{AC^2 - AB^2} = \sqrt{24^2 - 19\cdot4^2} = \sqrt{368\cdot64} = 19$  chains 20 links, the same as above.

2. The hypotenuse of a right-angled triangle is 960 links, and one of the sides 768 links; required the other side and angles.

*Ans. Side 576 links, angles  $53^\circ 8'$  and  $36^\circ 52'$ .*

3. In a right-angled triangle are given the hypotenuse = 3350 links, and a side = 2631 links; required the other side and area.

*Ans. Side 2074 links, area 27a. 1r. 5p.*

### CASE III.

*Given the right angle and the adjacent sides to find the other parts of the triangle.*

RULE.—As a side : radius :: the other side : tangent of angle adjacent to the first side.

As the sine of this angle : rad. :: second side : hypotenuse.

1. The sides of a right-angled triangle are AB 2880 and BC 3840 links; required the hypotenuse AC and angles A and C.

*By construction.*

Make AB = 2880, perpendicular to which make BC = 3840 links; join AC; then AC will be found = 4800 links, angle A =  $53^\circ 8'$ , and angle C =  $36^\circ 52'$ .



*By calculation.*

To find angle A.		To find AC.	
As side AB = 2880	3·45939	As sin. A = $53^\circ 8'$	9·90311
: rad.	10·00000	: rad.	10·00000
:: side BC = 3840	3·58433	:: side BC = 3840	3·58433
: tan. A = $53^\circ 8'$	0·12494	: hyp. AC = 4800	3·68122

Angle  $C = 90^\circ - 53^\circ 8' = 36^\circ 52'$ .

2. The sides adjacent the right angle of a right-angled triangle are 2683 and 4100 links; required the hypotenuse and angles.

*Ans. Hyp. 4900 links, angles  $56^\circ 48'$  and  $33^\circ 12'$ .*



3. The sides of a right-angled triangle are 6250 and 1250 links; required the hypotenuse, angles, and area.

*Ans. Hyp. 6374 links, angles 78° 41' and 11° 19', area 39a. Or. 10p.*

### OBLIQUE-ANGLED PLANE TRIANGLES.

#### CASE I. and II.

*Given two sides and an angle opposite one of them, or given two angles and a side opposite one of them, to determine the triangle.*

**RULE.**—As a side : sine of its opposite angle :: any other side : sine of its opposite angle.

And conversely, As sine of an angle : opposite side :: sine of any other angle : to its opposite side.

1. In an obtuse-angled scalene triangle are given the angle  $A = 32^\circ 15'$ , the angle  $B = 114^\circ 24'$ , and the side  $AB = 98$  chains, to find the sides  $AC$  and  $BC$ , and the other angle.

*By construction.*

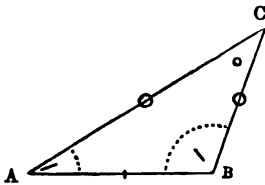

Make  $AB = 98$  chains, draw  $BC$ , making the angle  $B = 114^\circ 24'$ , also draw  $AC$  making the angle  $A = 32^\circ 15'$ , and meeting  $BC$  in  $C$ ; then  $AC$  and  $BC$ , being measured, will be found respectively  $162\cdot34$  and  $95\cdot12$ , and the angle  $C = 33^\circ 21'$ .

*By calculation.*

The angle  $C = 180^\circ - (114^\circ 24' + 32^\circ 15') = 33^\circ 21'$ .

Since the angle  $B$  is greater than  $90^\circ$ , its sine cannot be found in the tables, but by taking it from  $180^\circ$ , its supplement  $65^\circ 36'$  is obtained, the sine of which is also equal to the sine of the angle  $B$ .

To find AC.		To find BC.	
As sin. $C = 33^\circ 21'$	9·74017	As sin. $C = 33^\circ 21'$	9·74017
: side $AB = 98$	1·99123	: side $AB = 98$	1·99123
∴ sin. $B = 114^\circ 24'$	9·95937	∴ sin. $A = 32^\circ 15'$	9·72723
: side $AC = 162\cdot34$	2·21043	: side $BC = 95\cdot12$	1·97829

2. In an acute-angled scalene triangle are given  $AB = 60$  chains,  $BC = 95\cdot12$  chains, and the angle  $C = 33^\circ 21'$ ; required the greater side  $AC$ , and the angles  $A$  and  $B$ .

*By construction.*

Make  $BC = 95.12$  chains, draw  $AC$ , making the angle  $C = 33^\circ 21'$ ; with the side  $AB = 60$ , as radius, and centre  $B$ , describe an arc cutting  $AC$  in  $A$ ; then  $ABC$  is the triangle required.

$AC = 108.87$  chains, angle  $A = 60^\circ 38'$ , angle  $B = 86^\circ 1'$ .

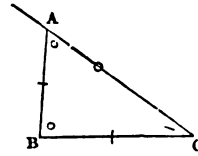
*By calculation.*

To find angle A.		To find AC.	
As $AB = 60$	1.77815	As $\sin. C = 33^\circ 21'$	9.74017
: $\sin. C = 33^\circ 21'$	9.74017	: $AB = 60$	1.77815
:: $BC = 95.12$	1.97827	:: $\sin. B = 86^\circ 1'$	9.99895
: $\sin. A = 60^\circ 38'$	9.94029	: $AC = 108.87$	2.03693

The sum of the angles  $C$  and  $A$  subtracted from  $180^\circ$ , leaves the angle  $B = 86^\circ 1'$ .

3. In the obtuse-angled scalene triangle  $ABC$  are given the two greater sides  $BC = 95.12$  chains,  $BA = 60$  chains, and the angle  $C$  opposite the lesser of them  $= 33^\circ 21'$ ; required the side  $AC$  and the angles  $A$  and  $B$ .

*By construction.*

Make  $BC = 95.12$  chains; draw  $CA$  indefinite, making the angle  $C = 33^\circ 21'$ ; then with  $BA = 60$  chains as radius, and centre  $B$ , describe an arc cutting  $CA$  in  $A$ ; draw  $BA$ ; then  $ABC$  is the triangle required.  $AC = 50.03$  chains;  $A = 119^\circ 22'$ ; and  $B = 27^\circ 17'$ .

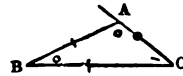
*By calculation.*

To find A.		To find AC.	
As $BA = 60$	1.77815	As $\sin. C = 33^\circ 21'$	9.74017
: $\sin. C = 33^\circ 21'$	9.74017	: $BA = 60$	1.77815
:: $BC = 95.12$	1.97827	:: $\sin. B = 27^\circ 17'$	9.66124
: $\sin. A = 119^\circ 22'$	9.94029	: $AC = 50.03$	1.69922
$= 180^\circ - (119^\circ 22' + 33^\circ 21')$ $= 27^\circ 17'$			

4. In a plane triangle  $AB = 98$ , and  $BC = 95.12$  chains, and angle  $C = 33^\circ 21'$ ; required the other parts.

Z

*By construction.*

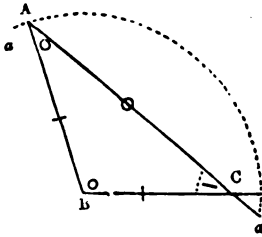

Make  $BC = 95.12$  chains, draw  $AC$  indefinite, making the angle  $c = 33^\circ 21'$ ; with  $AB$  as radius and centre  $B$  describe the arc  $aa$ , cutting  $AC$  in  $A$ ; then  $ABC$  is the triangle required.  $AC = 162.34$  chains;  $A = 32^\circ 15'$ ; and  $B = 114^\circ 24'$ .

*By calculation.*

To find angle A.		To find AC.	
As $AB = 98$	1.99123	As $\sin. C = 33^\circ 21'$	9.74017
: $\sin. C = 33^\circ 21'$	9.74017	: $AB = 98$	1.99123
: $BC = 95.12$	1.97827	: $\sin. B = 114^\circ 24'$	9.95937
: $\sin. A = 32^\circ 15'$	9.72721	: side $AC = 162.34$	2.21043
Angle $B = 180^\circ - (A + C) = 114^\circ 24'$ .			

5. In a plane triangle are given two angles  $79^\circ 23'$  and  $54^\circ 22'$ , and a side 1250 links opposite the first angle, to find the other parts.  
*Ans. Sides 1033.6 and 918.7 links.*

**CASE III.**

*Given two sides and their included angle to find the rest.*

**RULE.**—As the sum of the given sides : their difference : : co-tangent of half the included angle : tangent of half the difference of the required angles. This angle, added to half the complement of the included angle, gives the greater required angle, and subtracted gives the lesser. The other side is then found by Case I.

1. Given the side  $AB = 9800$  links, the side  $BC = 9512$ , and their included angle  $B = 114^\circ 24'$ , to find the other side and angles.

*By construction.*

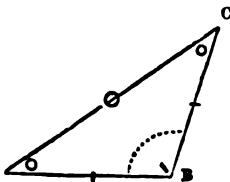

Make  $AB = 9800$  links, and the angle  $B = 114^\circ 24'$ ; draw  $BC$ , which make = 9512 links: then  $ABC$  is the triangle required. The angles  $A$  and  $C$  measure  $32^\circ 15'$  and  $33^\circ 21'$ , and  $AC$  16234 links.

*By calculation.*

To find the angles.	To find AC.
As AB + BC = 19312      4·28583	As sin. C = 33° 21'      9·74017
: AB - BC = 288      2·45939	: AB = 9800      3·99123
: : cot. $\frac{1}{2}$ B = 57° 12'      9·80919	: : sin. B = 114° 24'      9·95937
: tan. $\frac{1}{2}$ (C - A) 0° 33'      7·98275	: AC = 16234      4·21043
comp. $\frac{1}{2}$ B = 32° 48'	
sum $33^\circ 21' = \angle C$	
diff. $32^\circ 15' = \angle A$	

2. Given the two sides 103 and 126 chains, and their contained angle 56° 30', to determine the triangle.

*Ans. The angles 72° 20' and 51° 10', the side 110·3 chains.*

3. Two sides of a triangle are 34500 links and 17407, and their included angle 37° 20'; required the other angles and side.

*Ans. The angles 27° 4' and 115° 36', the side 23200 links.*

#### CASE IV.

*Given the three sides to find the angles.*

**RULE I.** From half the sum of the three sides subtract the side opposite the angle sought, add the logarithms of the half sum and remainder, and increase the index of the sum by 20; from the sum thus increased, subtract the sum of the logarithms of the sides containing the angle sought; the remainder, divided by 2, is the log. cosine of half the angle sought.

**RULE II.** From half the sum of the three sides subtract each of the sides containing the angle sought, add the logarithms of the two remainders, and increase the index of the sum by 20; also from half the sum of the three sides subtract the side opposite the angle sought, and add the logarithms of the half sum and remainder; then half the difference between these logarithmic sums is the log. tangent of half the angle sought.

The remaining angles may be found by Case I.

**NOTE.**—Rule II. is to be preferred when the angle sought is very small or near 180°.

1. Given the three sides AC = 98, AB = 162·34, and BC = 95·12 chains, to find the angles of the triangle.

*By construction.*

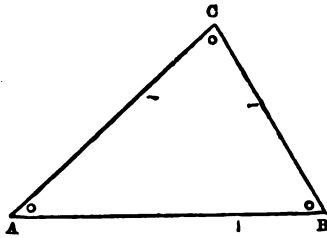

$C = 114^{\circ} 24'$ .

Draw the longest side  $AB = 162.34$  chains; with  $AC = 98$  as radius, and centre A, describe an arc; with  $BC = 95.12$  as radius, and centre B, describe another arc cutting the former in C; draw AC and BC; then ABC is the triangle required. The angles being measured, will be found  $A = 32^{\circ} 15'$ ,  $B = 33^{\circ} 21'$ , and

*By calculation.* (RULE I.)

$$\begin{array}{r} \frac{1}{2}(AB + AC + BC) = 177.73 \quad 2.24976 \\ \frac{1}{2}(AB + AC + BC) - BC = 82.61 \quad 1.91703 \end{array} \left. \begin{array}{l} \\ \end{array} \right\} \begin{array}{l} \text{sum} + 20 = 24.16679 \\ \\ \end{array}$$

$$\begin{array}{r} AC = 98 \quad 1.99128 \\ AB = 162.34 \quad 2.21043 \end{array} \left. \begin{array}{l} \\ \end{array} \right\} \begin{array}{l} \text{sum} = 4.20166 \\ \\ \hline 2)19.96513 \\ \hline 9.98257 \end{array}$$

$$\cos. \frac{1}{2} \angle A = 16^{\circ} 7' 30''$$

$$\frac{2}{2}$$

$$\angle A = 32^{\circ} 15' 0''$$

(RULE II.)

$$\begin{array}{r} \frac{1}{2}(AB + AC + BC) - AB = 15.39 \quad 1.18724 \\ \frac{1}{2}(AB + AC + BC) - AC = 79.73 \quad 1.90162 \end{array} \left. \begin{array}{l} \\ \end{array} \right\} \begin{array}{l} \text{sum} + 20 = 23.08886 \\ \\ \end{array}$$

$$\begin{array}{r} \frac{1}{2}(AB + AC + BC) = 177.73 \quad 2.24976 \\ \frac{1}{2}(AB + AC + BC) - BC = 82.61 \quad 1.91703 \end{array} \left. \begin{array}{l} \\ \end{array} \right\} \begin{array}{l} \text{sum} = 4.16679 \\ \\ \hline 2)18.92207 \\ \hline 9.46104 \end{array}$$

$$\tan. \frac{1}{2} \angle A = 16^{\circ} 7' 30''$$

$$\frac{2}{2}$$

$$\angle A = 32^{\circ} 15' 0''$$

The remaining angles may be found by Case I.

2. In a plane triangle are given the three sides 7000, 10400, and 14202 links to find the angles.

*Ans.*  $27^{\circ} 59'$ ,  $44^{\circ} 12'$ , and  $107^{\circ} 49'$ .

3. When the sides of the triangle are 2253, 2240, and 2400 links, what are the angles?

*Ans.*  $57^{\circ} 27'$ ,  $57^{\circ} 59'$ , and  $64^{\circ} 34'$ .

## SECTION IV.

### THE MEASUREMENT OF ANGLES.

The measurement of horizontal and vertical angles is usually taken with a theodolite.

## THE THEODOLITE.

Two of the principal parts of a theodolite are the circular brass plates A and B, which turn one upon the other horizontally on the vertical axis C. The circumference of the lower plate B is divided into  $360^\circ$ , and these again into half degrees. At the extremities of a diameter of the upper plate A are fixed two verniers for reading off the minutes in the divisions of the plate B. This plate has its clamp-screw H, and its adjusting-screw I, which clamp and adjust the whole instrument. To the plate A are fixed two spirit-levels, *d, d*, at right angles to each other; and a compass J concentric with it. It has also its clamp and adjusting screw (not shown in the figure). These two plates are used to take horizontal angles and lines.

The vertical semi-circle M turns on an axis supported by the frame KL, resting on the plate A; its axis passes perpendicularly through the common axis of the instrument; its motion is therefore perpendicular to the horizontal plates. It is graduated like the plate B, and by means of a vernier, fixed above the compass, the divisions can be read off to minutes. It has its clamp-screw O, and its adjusting screw P, and is used for taking vertical angles and lines.

The telescope is placed above the vertical circle in two receptacles, called Y's from their shape, and secured above by two clips *i, i*. It has a long spirit-level fixed beneath and parallel to it. The object-

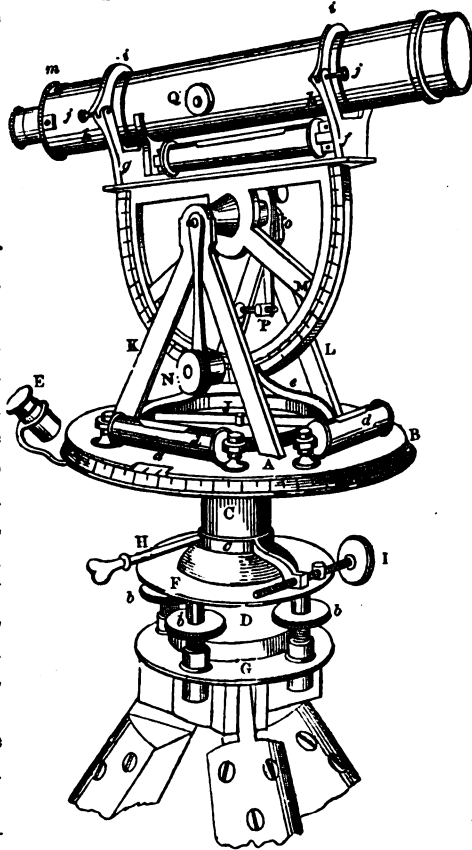

glass is adjusted to the sight by the screw Q and the eye-glass by moving it backwards and forwards with the hand.

Between what are called the two parallel plates F and G are fixed two pairs of conjugate screws, *b, b*, &c., by means of which the upper one F can always be made horizontal. These two plates are connected by the ball and socket D, and to the lower one G are fixed the three legs by which the whole instrument is supported.

*To take a horizontal angle with the theodolite.*

The bubbles in the two levels *d, d*, by the proper opening of the three legs of the theodolite, should be made central, and the plummet, suspended by a hook under the body of the instrument, should be made to hang above the station at which the angle is to be taken: this done, then unclamp the whole instrument by means of the screw H, the other motions being kept clamped. Set one of the two levels on the horizontal plate A over one of the pairs of opposite screws *b, b*, and the other level will be over the other pair, because the pairs of screws as well as levels, are conjugate, *i.e.*, at right angles to each other. If both the bubbles in the levels be not in the centre, loosen one of the conjugate screws, and tighten the corresponding one till the levels are accurately adjusted. Loosen and tighten the other pair if required, till the same result is obtained with respect to the other level. If the last operation throw the former adjustment out, repeat the adjustments on each pair of screws till both shall be level.

Next clamp the whole instrument; then unclamp the vernier plate A; set the broad arrow of the vernier to  $360^{\circ}$ , or zero, on the plate B, and reclamp the plate A. This must be carefully done by the microscope E and the adjusting-screw I.

Again unclamp the whole instrument, and turn it to the left of the two stations, between which the angle is to be taken, till the intersection of the cross wires in the telescope cut the flag or other object in the station as accurately as can be done with the hand; then clamp the screw H, and by slowly turning the screw I the greatest accuracy may be obtained.

Now unclamp the upper plate A, and turn it round till the cross wires in the telescope cut the object in the second station; then clamp and adjust with the two screws attached to the plate A, till having obtained perfect accuracy, read off the angle by means of the vernier with the glass E: in the same way, read off the angle with the other vernier, and the mean of the two will be the correct angle.

*To take a vertical angle.*

The horizontal plates being set level, as already explained, bring the bubble of the telescope level to the centre of its tube, observing at the same time whether the zero point of the vertical circle coincides with that of the vernier by the microscope N. These points being found to coincide, raise or depress the telescope till the cross wires cut the required object: then clamp with the screw O, and adjust with the screw P, and having obtained perfect accuracy, read off the angle, which will be an angle of depression, if the broad arrow be between the zero of the vertical circle and the object-glass of the telescope; and an angle of elevation, if beyond them.

## ADJUSTMENTS.

1. *To adjust the line of collimation.*

Direct the telescope to some well-defined object at a great distance, adjust it till the intersection of the wires cut it accurately, then turn the telescope on its axis, and observe whether the intersection of the wires still continues to cut it during a whole revolution. If it does, it is in adjustment; if it does not, the line of collimation, or optical axis of the telescope, is not in the line joining the centres of the eye and object-glasses.

*To correct this error*, turn the telescope on its axis, and by means of the four conjugate screws, *m*, &c., correct for half the error, alternately loosening one screw and tightening its opposite one.

2. *To adjust the axis of the level with that of the telescope.*

Make the telescope perfectly level by the tangent screw P; then reverse the telescope in the V's: if the level remains the same, it is in adjustment; if not, correct for half the error by the screw *f* at the end of the level, and for the other half by the screw P. Replace the telescope in its former position, and correct again, if necessary.

3. *To make the axes of the levels on the vernier plate parallel to it.*

Set one of the levels over one pair of the conjugate screws, *b*, *b*, &c., then the other level will be over the other pair; make both the bubbles come to their respective centres, turn the instrument half round, and if the bubbles deviate from their centres, correct half the error by the small screws on the levels, and the other half by the screws *b*, *b*, &c. Repeat this operation till the bubbles are central in every position throughout a whole revolution of the instrument.



## THE VERNIER.

The vernier is a contrivance for measuring the fractional parts of the half-degrees on the lower plate of the theodolite. The space occupied by 29 or 31 of these half-degrees is used to form the scale of the vernier, and divided into 30 parts; whence it is obvious that the difference of one division on the vernier and one on the lower plate will be  $\frac{1}{30}$ th in excess or defect of the  $\frac{1}{2}^\circ$  on the lower plate, or a single minute; and the difference between 2, 3, 4, &c., divisions on the two plates will be 2, 3, 4, &c., minutes. Hence the following methods of finding the minutes corresponding to a fractional part of a degree on any given angle, &c.

1. *To find the minutes in the fractional part of a degree of a given angle by the vernier.*

If the broad arrow of the vernier is between a full degree and a half-degree, say between  $40^\circ$  and  $40\frac{1}{2}^\circ$ , then the angle is  $40^\circ$  and as many minutes as are shown by the number of the first division-line of the vernier that coincides with a division on the lower plate, reading forward as the degrees are numbered. If the broad arrow be between  $40\frac{1}{2}^\circ$  and  $41^\circ$ , then the angle is  $40^\circ 30'$  plus the number of minutes shown by the first coincidence of the divisions of the vernier and those on the lower plate. If the coincidence take place at the 13th division on the vernier, then the angle in the former case is  $40^\circ 30'$ , and in the latter  $40^\circ 30' + 13' = 40^\circ 43'$ .

2. *To set the theodolite to an angle of any number of degrees and minutes.*

If the required angle be  $48^\circ 28'$ , bring the vernier till the broad arrow shall be in such a position within the half-degree above  $48^\circ$ , that the division numbered 28 on the vernier shall coincide with the same numbered line on the lower plate; the theodolite is then set to the required angle.

## SECTION V.

## TRIGONOMETRICAL SURVEY OF HEIGHTS AND DISTANCES.

## PROBLEM I.

*To measure that part of a base line which crosses a river.*

Let DBA be the direction of the line, which has been measured to the edge  $b$  of the river; it is required to find the width  $ba$  of the river.

1. Having set up flags at any convenient points B and A (supposing sight not to be obstructed), range and measure the line BC perpendicular to BA, and let  $BC = 576$  links, then take with the theodolite the angle  $ACB$ , which suppose to be  $53^\circ 8'$ ; required the distance BA, and from thence the width of the river  $ba$ , the distance  $Bb$  being 36 links, and  $aA$  43 links.

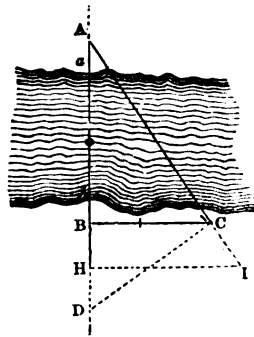

$\sin. A = \cos. C = 53^\circ 8'$	.	.	.	9.77812
: side BC = 576	.	.	.	2.76042
: : $\sin. C = 53^\circ 8'$	.	.	.	9.90311
: BA = 768	.	.	.	2.88541

$ba = 768 - (36 \times 43) = 689$  links, the breadth of the river.

The distance BA may be found by construction. See solution of right-angled plane triangles, Case 1, Ex. 2.

NOTE.—If the angle  $ACB$  had been  $45^\circ$ , the angle  $A$  would also have been  $45^\circ$ , and therefore  $BA = BC$ . In this case no calculation or construction would be required. A cross-staff, having also sights placed at this angle, is sometimes used for thus expeditiously solving this problem, when the nature of the ground admits of the line  $BC$  being measured of a sufficient length for the purpose.

2. The distance BA may be found independently of trigonometry thus. Having measured the perpendicular  $BC = 576$  links, as in the last example, range and measure a line  $CD$  perpendicular to  $CA$ , and meeting the base-line  $DBA$  in  $D$ ; measure  $DB = 432$  links: then (Euc. VI. 8)

$$\begin{aligned} \text{As } BD : BC :: BC : BA, \\ \text{that is, } 432 : 576 :: 576 : 768 = BA, \\ \text{or } BA = \frac{BC^2}{B} = \frac{(576)^2}{432} = 768 \text{ links.} \end{aligned}$$

3. Should obstructions prevent the measurement of the perpendicular  $CD$ , let the line  $CD = 576$  be measured as before; at any convenient distance  $BH =$  (suppose) 200 links on the base-line, range and measure  $HI$  perpendicular to  $DBA$ , till the point  $I$  shall be in a direct line with the flags at  $A$  and  $C$ , and let  $HI = 726$  links; then

$$\begin{aligned} &\text{As HI} - \text{BC} : \text{BH} :: \text{BC} : \text{BA},^* \\ &\text{that is, } 726 - 576 : 200 :: 576 : 768 \text{ links} = \text{BA}, \\ \text{or } \text{BA} &= \frac{\text{BH} \times \text{BC}}{\text{HI} - \text{BC}} = \frac{200 \times 576}{150} = 768 \text{ links.} \end{aligned}$$

4. Should impediments prevent the lines BC, HI being measured perpendicular to HBA, measure BC to make any angle with HA, and at a convenient distance BH measure HI parallel to BC, which may be done by erecting two equal perpendiculars to BC, the point I being in a right line with A and C as before.

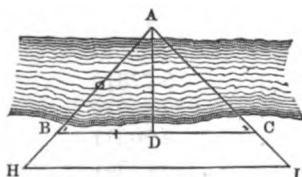

The rule for finding BA will be the same as in the last example; the calculation in both cases may be readily performed on the ground.

5. Lastly, if the nature of the ground be such that none of the four preceding methods can be adopted, neither to the right nor to the left of the base-line, measure BC in the most convenient direction, and take the angles ABC, ACB with the theodolite; then by taking the sum of these angles from  $180^\circ$ , the angle A will become known, whence, by Case I. of oblique-angled triangles:

$$\text{As } \sin. \angle A : \text{BC} :: \sin. \angle C : \text{BA}.$$

This problem may also be solved by construction.

*Examples for practice.*

1. BC = 308 links (fig. to first method) is measured perpendicular to BA and CD is ranged perpendicular to CA, meeting DA in D, the distance BD being 400 links, and the flags at B and A being at the water's edge; required the distance BA.

*Ans. By the second method BA is found = 237 links nearly.*

2. Given BC = 400 (fig. to first method), HI = 520, and BH = 180 links, to find BA.

*Ans. By the third method BA is found = 600 links.*

3. Given BC = 8 chains, and the angles at B and C respectively  $30^\circ$  and  $45^\circ$ ; required the distance BA, and the perpendicular width AD of the river.

*Ans. BA = 585 links, and AD = 292 links.*

\* This rule is derived from similar triangles; for  $\text{HI} : \text{BC} :: \text{HA} : \text{BA}$ , and  $\text{HI} - \text{BC} : \text{HA} - \text{BA} :: \text{BC} : \text{BA}$ , i.e.,  $\text{HI} - \text{BC} : \text{HB} :: \text{BC} : \text{BA}$ .

## PROBLEM II.

To continue the direction and measurement of a given line when buildings or other obstructions stand in the way, which can be avoided by going to right or left.

1. At any convenient point A in the given line  $aAc$ , which is obstructed by the buildings H, take an angle  $aAB = 120^\circ$  (thus making the angle  $CAB = 60^\circ$ ); range and measure the line AB, till, by taking an angle  $B = 60^\circ$ , the line BC will clear the obstructions at H; then measure  $BC = AB$ , and take the angle  $BCc = 120^\circ$ . Then  $Cc$  is in the range of the given line  $aAc$ , and  $AC = AB$  or  $BC$ , the triangle ABC being thus made equilateral; hence the measurement of the line  $aAc$  may proceed from C, after having added the distance thus found to the measure at A.

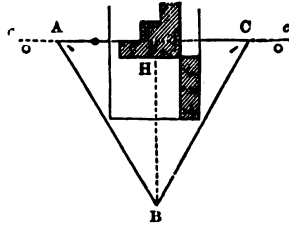

2. If the nature of the ground be such as not to admit line AB to make with  $aA$  an angle  $aAB = 120^\circ$ , take any other angle, and suppose it to be  $132^\circ$ , which taken from  $180^\circ$  leaves the angle  $CAB = 48^\circ$ ; measure AB, till by taking an angle at B  $= 84^\circ =$  twice the complement of the angle CAB, the line BC may clear the buildings; then measure  $BC = BA$ , taking the angle  $cCB$  also  $= 132^\circ$ , and continue the line in the direction  $cc$ . The triangle ABC is thus made isosceles, and a perpendicular let fall from B to H on AC will divide ABC into two equal right-angled triangles.

Hence as rad. or  $\sin. 90^\circ$  : side AB ::  $\sin. \frac{1}{2} \angle B$ , or  $42^\circ$  : AH =  $\frac{1}{2}$  AC, whence AC becomes known.

3. If it be convenient to take the angle  $aAB = 135^\circ$ , the angle B  $= 90^\circ$ ,  $AB = BC =$  (suppose) 800 links, and lastly the angle  $cCB = 135^\circ$ , thus making each of the angles CAB, ACB  $= 45^\circ$ , the triangle being right-angled at B, as well as isosceles. Hence, by Euc. I. 47,

$$AC = AB \times \sqrt{2} = 800 \times 1.414 = 1131 \text{ links.}$$

NOTE.—By any of these methods the distance AC between any two given points A and C may be found, when sight is not obstructed, as when H is a lake or projection of a sea-coast, intervening between A and C, that cannot be measured across with the chain.



and the angle  $cab$ , to find  $cb$ ; to which add  $aa = bb =$  height of the centre of the instrument, and the sum will be the height of the tower.

**Ex.** Let  $AB = 200$  feet, the angle  $cab = 46^\circ 30'$ , and the height of the centre of the instrument 5 feet; required the height of the tower.

$$\text{As rad.} = \sin. 90^\circ : \tan. cab = 46^\circ 30' :: 200 = ab : cb = 210.76$$

$$aa = bb = 5$$

$$\text{The height of the tower } BC = 215.76 \text{ feet.}$$

### PROBLEM V.

*To find the height of a tower or any other object, standing on an horizontal plane, the base of the tower, &c., being inaccessible.*

Let  $CB$  be a spire or steeple inaccessible on every side, on account of trees, a portion  $AD$  of the ground line  $AB$  being horizontal, and passing through the bottom of the spire. Take the angle  $CDB = 51^\circ 30'$ , measure the distance  $AD = 75$  feet, and take the angle  $A = 26^\circ 30'$ . Required the height of the spire and the distance of the first station from the centre of its base.

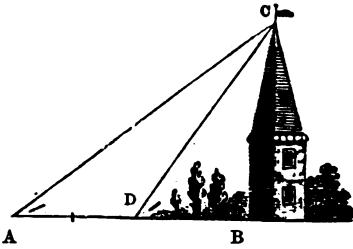

Subtract the angle  $A$  from the angle  $CDB$ , the remainder  $25^\circ =$  angle  $ACD$ . Then in the oblique-angled triangle  $ADC$ ,  $AD$  and all the angles are given to find  $DC = 79.18$ ; and in the right-angled triangle  $DBC$ , the hypotenuse  $DC$  and angle  $BDC$  are given to find  $BC = 61.97$ , and  $DB$  equal  $49.29$  feet.

Or  $BC$  may be found by a single operation by the formula  $BC = \frac{AD \times \sin. A \times \sin. D}{\text{rad.} \times \sin. (D - A)}$ , that is, add together the logarithms of  $AD$ , and of the sines of the angles  $A$  and  $D$ ; from the sum subtract the  $\log. \sin. (D - A)$  with its index increased by 10, and the remainder is the  $\log.$  of the height  $BC$ . Thus,

Log. $AD$	. . . .	1.87506
$\sin. 51^\circ 30'$	. . . .	9.89354
$\sin. 26^\circ 30'$	. . . .	9.64953
		21.41813
$\sin. 25^\circ + 10$	. . . .	19.62595
Log. $BC = 61.97$	. . . .	1.79218

To this result the height of the instrument should be added.

*Examples for practice on the two last problems.*

1. At the distance of 45 feet from the bottom of a steeple, on an horizontal plane, the angle of elevation is  $48^{\circ} 12'$ , and the height of the instrument 5 feet. Required the height of the steeple.

*Ans. 55 feet 4 inches.*

2. The angles taken at two stations A and D (see last fig.) on an horizontal plane passing through the base of an inaccessible tower CB, are  $28^{\circ} 34' = CAB$ ,  $50^{\circ} 9' = CDB$ , the distance of stations being 30 yards = AD; required the height of the tower, and its distance from the station D, the height of the instrument being  $5\frac{1}{4}$  feet.

*Ans. Height of tower 31.69 yards; distance from D = 24.99.*

PROBLEM VI.

*To find the height of a tower standing on the side or top of an inaccessible hill.*

Let CE be a tower on the inaccessible hill E, ADB the horizontal plane, the point B being in the prolongation of the line CE; *adb* the level of the centre of the instrument, with which the angles *a*, *cdb*, *edb* were taken, and found to be respectively  $44^{\circ}$ ,  $67^{\circ} 50'$ ,

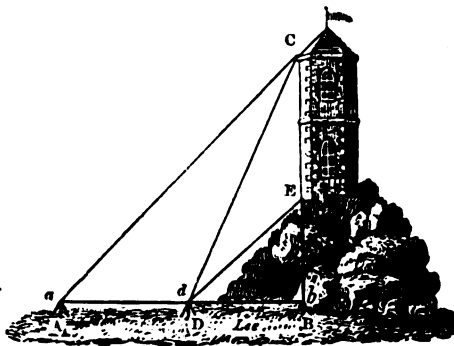

and  $51^{\circ}$ . Required the heights of the tower and hill, the height of the instrument being 5 feet, and  $ad = 134$  yards.

Subtract the angle *a* from *cdb*, the remainder  $23^{\circ} 50' = aCd$ : hence all the angles of the triangle *aCd* are given, and the side *ad*, to find  $cd = 230.36$  yards.

In the triangle *CdE* all the angles are given, *viz.*  $CdE = 67^{\circ} 50' - 51^{\circ} = 16^{\circ} 50'$ ,  $dCE = 90^{\circ} - 67^{\circ} 50' = 22^{\circ} 10'$ . Hence the angle *CEd* =  $141^{\circ}$ , and  $CE = 106$  yards, the height of the tower.

In the right-angled triangle *Cdb*, the angle *Cdb* and *DC* are given to find  $cb = 213.34$  yards: hence  $= bE BC - CE = 107.34$  yards, to which add the height of the instrument = 5 feet =  $1.66$  yards, and there results  $EB = 109.01$  yards, the height of the hill.

*Examples for practice.*

1. The angles of elevation of a castle standing on the top of a rock are  $CAD = 40^\circ$ ,  $CDB = 63^\circ 20'$ , and  $CDE = 14^\circ 30'$ , and the distance of the stations A and D, which are in a line with the castle, is 40 yards. Required the height of the castle.

*Ans. 24.69 yards.*

2. When the angles CAD, CDB, and CDE are respectively  $30^\circ 30'$ ,  $59^\circ 5'$ , and  $13^\circ 52'$ , and the distance AD on the horizontal plane = 52 yards, what is the height of tower ?

## PART IX.

## TRIGONOMETRICAL SURVEY.

SECTION I. Rules for finding the areas of triangles, &c., by logarithms.

SECTION II. To survey a wood.

SECTION III. To survey a road or river.

SECTION IV. The practice of taking bearings at two stations.

SECTION V. To survey a town or city.

SECTION VI. To range lines and take bearings in extensive surveys.

SECTION VII. To survey with the circumferentor.

## SECTION I.

RULES FOR FINDING THE AREAS OF TRIANGLES, ETC., BY LOGARITHMS.

## PROBLEM I.

*To find the area of a triangle when two sides and their included angle are given.*

To the logarithms of the two sides in links add the log. sine of the included angle, and from the sum subtract 15.30103, and the remainder is the log. of the area in acres and decimals of an acre.

Ex. The two sides of a triangle are 960 and 576 links, and their included angle  $53^\circ 8'$ ; required the area.



$$\begin{array}{r}
 \text{Log. } 960 \dots 2.98227 \\
 \phantom{\text{Log. }} 576 \dots 2.76042 \\
 \text{Log. sin. } 53^\circ 8' \dots 9.90311 \\
 \hline
 \phantom{\text{Log. }} 15.64580 \\
 \phantom{\text{Log. }} 15.30103 \\
 \hline
 \text{Log. } 2.212 \dots 0.34487 \\
 \phantom{\text{Log. }} \phantom{0.} 4 \\
 \hline
 \phantom{\text{Log. }} 0.848 \\
 \phantom{\text{Log. }} \phantom{0.} 40 \qquad \text{A. R. P.} \\
 \hline
 \phantom{\text{Log. }} 32.920 \quad \text{Ans. } 2 \quad 0 \quad 33
 \end{array}$$

PROBLEM II.

*To find the area of a triangle when two angles and their included side are given.*

From the sum of twice the log. of the given side in links and the log. sines of the given angles, subtract the log. sine of the sum of the given angles increased by 15.30103, and the remainder is the area in acres.

Ex. Two angles of a triangle are  $59^\circ 46'$  and  $60^\circ 14'$ , and their included side 1000 links ; required the area.

$$\begin{array}{r}
 \text{Log. } 1000 \dots 3.00000 \\
 \phantom{\text{Log. }} \phantom{3.} 2 \\
 \hline
 \phantom{\text{Log. }} 6.00000 \\
 \text{Log. sin. } 59^\circ 46' \dots 9.93665 \\
 \phantom{\text{Log. sin. }} 60^\circ 14' \dots 9.93855 \\
 \hline
 \phantom{\text{Log. sin. }} 25.87520 \\
 \text{Log. sin. } (59^\circ 46' + 60^\circ 14') = 120^\circ \dots 9.93753 \} \\
 \phantom{\text{Log. sin. }} 15.30103 \} \cdot 25.23856 \\
 \hline
 \text{Log. } 4.332 \dots 0.63664 \\
 \phantom{\text{Log. }} \phantom{0.} 4 \\
 \hline
 \phantom{\text{Log. }} 1.328 \\
 \phantom{\text{Log. }} \phantom{1.} 40 \qquad \text{A. R. P.} \\
 \hline
 \phantom{\text{Log. }} 13.120 \quad \text{Ans. } 4 \quad 1 \quad 13
 \end{array}$$

PROBLEM III.

*To find the area of a triangle when the three sides are given.*

From the half sum of the three sides subtract each side separately, add together the logarithms of the half sum and the three remainders in links, and divide the sum by 2, diminishing the index by 5, and the result is the log. of the area in acres.

Ex. The three sides of a triangle are 4080, 5040, and 6100 links ;  
required the area. *Ans.* 102a. Or. 16p.

## PROBLEM IV.

*To find the area of a trapezium when the two diagonals and the  
angle made by their intersection are given.*

The rule for the area is the same in this as in Prob. I., the  
diagonals being used as sides.

## SECTION II.

## TO SURVEY A WOOD.

The following figure represents a wood, the plan and area of which  
are required.

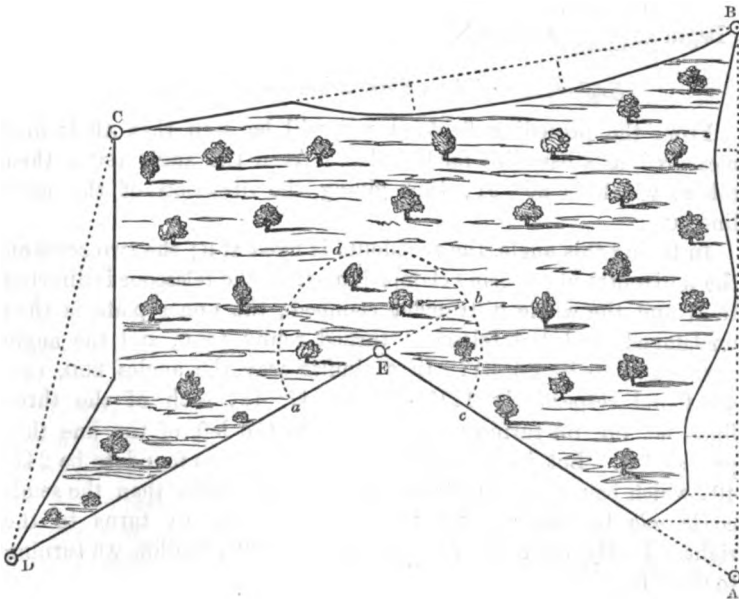

Fix station-flags so that the lines compassing the wood shall be as  
near it as possible, that the offsets may be conveniently taken, and  
that the stations, at the same time, are on ground proper for  
2 A

fixing the theodolite. Let the stations be A, B, C, D, and E, the field-notes being as below.

	to +C			from +E	58° 20'		
	1340				to +A		to +B
0	1050			0	896		
+	1000			0	675		
50	700			from +D	241° 40'		to +E
60	400				+E		go SE.
0	000				to +E		
from +A	80° 31'	to +C		0	894		
	+B	go W.		0	000		
	+B			from +C	47° 48'		to +E
0	1150				+D		go NE.
+	1000				to +D		
50	900			00	950		
00	550			120	500		
100	300			0	000		
110	160			from +B	111° 41'		to +D
188	110				+C		go S.
0	000						
Begin at	+A	go N.					

*Explanation of the method of taking the angles, &c.*

From the preceding field-notes it will be seen that AB is first measured, as a base line for the plan. At B the angle ABC is then taken, which is 80° 31', thus giving the direction of the next line BC.

In taking this angle, the theodolite is fixed at B; the two zeros on the horizontal plates being clamped together, the telescope is directed to A, and the whole instrument clamped; the upper plate is then unclamped, and the telescope turned round to C, and the angle ABC found to be 80° 31'. In a similar way the angles BCD, CDE are found respectively 111° 41' and 47° 48', each of the three lines BC, CD, DE turning respectively to the left of the line that preceded it. But in taking the angle DEA, it is found to be 241° 40', which being greater than 180°, that is, greater than the semi-circle *adb* by the arc *bc*; therefore, the line EA turns to the right. Lastly, the angle EAB is found = 58° 20', the line AB turning to the left.

It thus appears that the magnitude of the angle determines whether the new line turns to the right or the left of the old one, that is, *the new line turns to the left of the old one if the angle is less than 180°, and to the right if greater than 180°, provided the zero of the instrument be directed towards the beginning of the old line*; therefore

the bearings of the lines BC, CD, DE, AE, though put down by way of check, may be omitted in the field-notes.

The remainder of the field-notes are similar to those given in the preceding parts of this work, and therefore require no further explanation.

*On plotting and proving the work.*

Draw the line AB in the given direction, and of the given length, 1150 links, as a base line; place the centre of the protractor at B with its straight edge close against AB, and from the end towards A mark off  $80\frac{1}{2}^\circ$ , then through B and the protractor-mark draw BC = 1340 links. Proceed similarly with the lines CD, CE, and the angles C, D. At E the angle is  $241\frac{3}{4}^\circ$ : the next line EA must therefore turn to the right, and the angle to be marked off at E must be  $360^\circ - 241\frac{3}{4}^\circ = 118\frac{1}{4}^\circ$ ; or, if the protractor be a circular one, the whole angle may be marked off at once. At A, the commencement of the base line, the angle is  $58\frac{3}{4}^\circ$ , which is a check angle to prove the accuracy of the previous work.

Moreover, since *the sum of all the interior angles of any polygon is equal to twice as many right angles as the figure has sides, lessened by four*; as the given figure has five sides, the sum of all its interior angles must be  $2 \times 5 - 4 = 6$  right angles =  $6 \times 90^\circ = 540^\circ$ , that is,

$$\begin{array}{r} 80^\circ 31' \\ 111^\circ 41' \\ 47^\circ 48' \\ 241^\circ 40' \\ 58^\circ 20' \\ \hline 540^\circ 0' \text{ proof, as respects the angles.} \end{array}$$

The angles may, therefore, be considered as having been accurately taken. But *the proof of the plotting being correct, is when the work is found to close*, that is, when the line EA exactly reaches to the starting-point A, or so very near to it that the error is immaterial.

Having plotted the work, the area is found, by the methods already given in the preceding parts of this work, to be 9a. 1r. 22p.

*A large pond, mere, or lake is surveyed and mapped precisely in the same manner as in the case of the wood just given.*

### SECTION III.

#### TO SURVEY A ROAD OR RIVER.

1. The figure Problem V. Part IV., represents a road, the map of which is required from the following notes; and as the angles at

2, 6, 9, and 12 are taken by the theodolite, the tie-lines from 3 to 4, from 5 to 7, &c., will not be required.

	554	to fence			to +14	
20	512	+6		78	350	60
50	450			68	200	44
52	380	70		50	100	80
20	300	80		from +1	234° 20'	to +14 ch
18	100	93		from +9	276° 8'	to +14.
from +1	108° 20'	to +6			+12	
	+2					
	480	to fence			752	to fence
	400	+2		30	720	+12
38	350			70	650	
15	300			86	560	33
28	200	80		76	300	50
55	000	70		130	165	36
Begin at	+1	go N. $\frac{1}{4}$ E.			135	cr. fence.
				from +6	58° 20'	to +12.
					+9	
					+9	
					700	
					600	cr. fence.
				38	480	84
				40	300	60
				52	180	65
				50	100	
				from +2	297° 13'	to +9.
					+6	

*Explanatory remarks, &c.*

Station-flags being set up at 1 and 2, and the line measured, a flag is then set up at 6, and the angle 2 6 taken, which being less than 180°, shows that the line 2 6 is on the left of 1 2. Having measured the line 2 6, the angle 2 6 9 is next taken, which, being 297° 13', or greater than 180°, shows that the line 6 9 turns to the right. Similar observations will apply to the remaining lines. But at station 12, besides the angle to determine the position of the line 12 14, a check angle is taken between an imaginary line, drawn from 12 to 1 and the line 12 14, which is 234° 20'; therefore, after the work is plotted, the protractor will show this angle if the work be right.

If the station-flag at 1 cannot be seen from the station at 12, a flag may be fixed in any other given point in the line 1 2, or in its prolongation, for the purpose of taking the check angle; and if the road is very long, and has several bends, a proportionate number of check angles ought to be taken.

The method of plotting the preceding work will be sufficiently obvious from the example given in Section II. of the survey of a wood.

2. If the figure just referred to, *i.e.* Problem V. Part IV., represent a river, it may be surveyed in the following way.

Measure a system of lines *ac, cm, &c.*, to *z*, similar to those used in the last example, and take the angles between them, but omitting *ab, nr, &c.*, which being tie-lines are not required.

If the breadth of the river is very unequal, a similar system of lines must be used on the other side of it: but if its width is everywhere nearly equal, its breadth may be found by any of the methods given in Prob. I., Heights and Distances, or by Prob. X. Part III.

The map of the river being thus obtained, the area, if required may be readily found by one or other of the methods already given.

SECTION IV.

THE PRACTICE OF TAKING BEARINGS AT TWO STATIONS.

Let F, G, H, E, D, C, be six points, or stations, the positions of which, and the distances FG, GH, HE, ED, DC, CF, are to be determined. Measure a base line AB on convenient and level ground, and at A and B angles being taken between AB and the points F, G, H, E, D, C, their positions and distances will be determined by the intersection of the lines that include these angles, as shown in the figure.

The lines FG, GH, &c., being thus determined, may form new base lines for other portions of the survey.

NOTE.—It is not necessary that the stations A and B should be in the lines EH, CF, as in the figure, these positions being only assumed as being convenient for checking the work, which can be better done by taking angles at any given point *o* in AB.

The base AB, and the several angles taken at the stations A and B, are shown in the following field-notes, also the angles taken at *o*, a station in AB, as check angles.

From + B	352° 28'	to + C
	322° 37'	to + D
	287° 14'	to + E
	107° 14'	to + H
	48° 18'	to + G
	16° 56'	to + E
	+ A	
	+ B	
	4323	
	+ 0	
	2220	
Begin at	+ A	go W.

From + A	341° 11'	to + H
	292° 18'	to + G
	221° 14'	to + F
	167° 44'	to + C
	99° 59'	to + D
	44° 17'	to + E
	+ 0	
	348° 28'	to + H
	328° 38'	to + G
	310° 56'	to + F
	130° 56'	to + C
	48° 48'	to + D
	23° 40'	to + E
	+ B	
From + A		

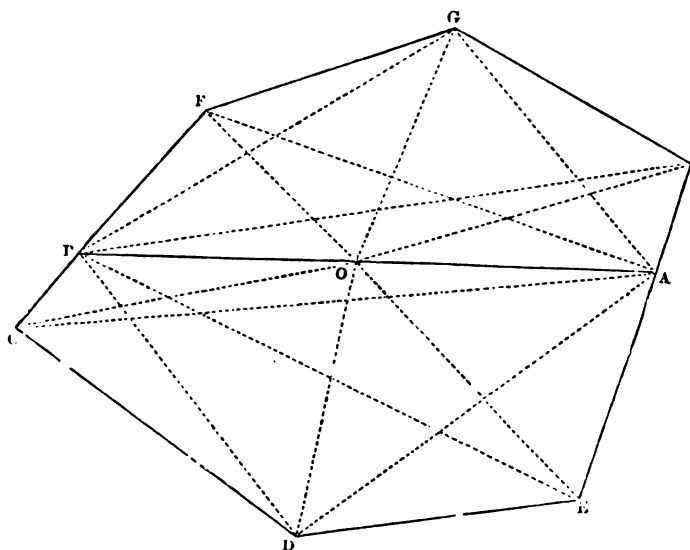

*On laying down and proving the work.*

Draw the base line  $AB$  in the given direction, and of the given length, 4323 links, making the station  $O$  thereon, for the check or proof angles. With the protractor, applied to the line  $AB$ , and its centre at  $A$ , lay off the angle  $BAF = 16^\circ 56'$ , reckoning from  $B$ . Move its centre to  $B$ , and lay off the angle  $ABF = 360^\circ - 310^\circ 56' = 49^\circ 4'$ , reckoning from  $A$ , and the intersection of the lines  $AF$ ,  $BF$ , will give the point  $F$ . The position of the point  $G$  may be determined in the same way, by the intersection of  $AG$ ,  $BG$ ; as also the points  $H$ ,  $E$ ,  $D$ ,  $C$ ; recollecting that when the angles exceed  $180^\circ$  to take them from  $360^\circ$ , and to plot the remainder from right to left, looking from the centre of the instrument along the base line.

If the work be correct, the lines  $HE$ ,  $CF$  will respectively pass through the stations  $A$ ,  $B$ ; this, however, does not check the points  $D$  and  $G$ : therefore join  $OD$ , and apply the protractor to  $AB$  with its centre at  $O$ , and if it show the angle  $AOD$  to be  $99^\circ 59'$ , the point  $D$  is in its right position. In the same way, if the angle  $AOG = 360^\circ - 292^\circ 18' = 67^\circ 42'$ , the point  $G$  is in its correct position; and similarly with respect to the points  $E$ ,  $C$ ,  $F$ ,  $H$ .

*By calculation.*

In the triangle  $ABF$  are given the side  $AB$ , and its adjacent angles  $BAF = 16^\circ 56'$ , and  $ABF = 360^\circ - 310^\circ 56' = 49^\circ 4'$ , from which

AF and BF may be found. Again, in the triangle ABG are given AB, and the angles BAG =  $48^{\circ} 18'$ , and  $ABG = 360^{\circ} - 328^{\circ} 38' = 31^{\circ} 22'$ , from which AG may be found. Now in the triangle AFG, the two sides AF and AG, being determined by the two preceding operations, may be considered as given, and their included angle FAG is also given in the field-notes, being =  $48^{\circ} 18' - 16^{\circ} 56' = 31^{\circ} 22'$ , from which FG may be found. And similarly GH, HE, &c., may be found.

By either of the preceding methods are found CD = 2576, DE = 2102, EH = 2625, HG = 1977, GF = 1995, and FC = 2071 links.

## TWO EXAMPLES FOR PRACTICE BY TWO STATIONS.

It is required to find the positions and distances of the points D, E, F and G, from the field-notes No. 1, also from the field-notes No. 2.

No. 1.				No. 2.	
From +A	331 2'	to +G	From +A	336° 0'	to +G
	314° 0'	to +F		321° 30'	to +F
	70° 42'	to +E		68° 40'	to +E
	27° 50'	to +D		31° 30'	to +D
	at +B			at +B	
From +B	326° 0'	to +E	From +B	319° 26'	to +E
	269° 5'	to +D		381° 40'	to +D
	46° 25'	to +G		50° 14'	to +G
	22° 0'	to +F		24° 10'	to +F
	at +A			at +A	
	to +B			to +B	
	8000			15421	
	+0			+0	
	4000			6000	
Begin	at +A		Begin	at +A	

## SECTION V.

## TO SURVEY A TOWN OR CITY.

Let the following figure represent a portion of a town or city, the map of which is required.

Begin the survey at the meeting of three or more principal streets, and select a station, as A, where the longest prospects can be obtained along all the streets diverging from it, in order to get the longest main or station lines. Having fixed the theodolite at that station, take the direction of one of the principal streets as a base line, as AB,



which must be directed to some well-defined object, as to the right or left side of a door or window, or a projecting corner of a house, or to an angle, or upright post of railing, or any other mark that can be well remembered ; a description of which should be also put down in the field-book.

Angles between this base line and the other lines, diverging from station A must then be taken, the objects to which these lines are directed being well defined, in the manner already explained with respect to the base line.

The lines thus set out must next be measured with the chain, taking offsets to all projecting corners of buildings, bends, or openings ; and

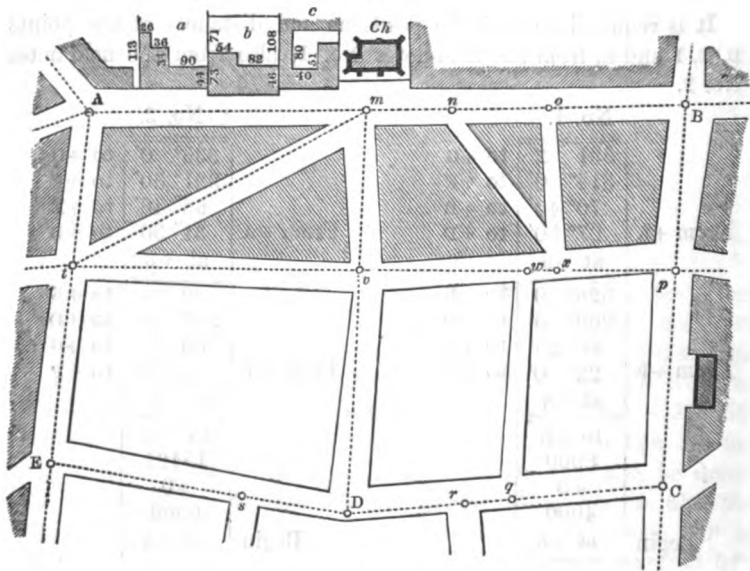

to all public buildings, as churches, markets, &c., also to statues, obelisks, &c., leaving stations at the ends of the streets to the right and left of the line, and taking the angles of their several directions. The same process is to be repeated on the other lines till the whole is finished.

Thus, fix the theodolite at A, and take the bearings of all the streets meeting there ; then measure AB, taking offsets to the openings, corners, &c., of buildings, leaving stations at *m*, *n*, *o*, opposite the directions of the streets on the right. If the survey is for a railway, for which some of the buildings are required to be taken down, the entries should be made at a sufficient distance

apart to admit sketches of the buildings, gardens, yards, &c., belonging to the different proprietors, with the dimensions put upon them, as shown at  $a$ ,  $b$ , and  $c$ ; so that the several parts may be accurately mapped, and their areas determined, for the purpose of their valuation. The same should be done in parish maps, where the valuations of the different properties are required for the purpose of rating, &c.

The base line  $AB$  being measured, fix the theodolite at  $B$ , and take the angles of the several streets diverging from that point, then measure  $BC$ , taking the offsets, and making stations opposite the directions of the streets to the right and left, as at  $p$  and  $c$ . Make  $C$  the third station, at which take the angles and proceed to  $D$ , as before. From thence proceed in a similar manner to  $E$ , from which return to the first station  $A$ , and in measuring  $EA$  leave a station at  $t$ , from which the station  $m$  in  $AB$  may be joined by the line  $tm$ , and the station  $p$  in  $BC$  by the line  $tp$ , crossing the line joining the stations  $D$  and  $m$  in  $v$ , stations in all these lines having been left opposite the streets and lanes, to the right and left of them, as at  $q$ ,  $r$ ,  $s$ ,  $w$ ,  $x$ .

If the interior angles of the five-sided figure  $ABCDE$  have been correctly taken, their sum will be equal to  $2 \times 5 - 4 = 6$  right angles, as shown in Sect. I. Also the line  $tm$  determines the position of  $AE$ , independent of the angles; in the same manner, the lines  $Dm$ ,  $tp$ , determine the positions of the line  $BC$ ,  $CD$ , and  $DE$ . But lines can seldom be obtained in large towns thus effectually, to tie the main lines independently of the angles, this result being referable to the line  $tm$ , which is actually a tie-line; therefore, when the peculiar position of the street, in which the line  $tm$  is drawn, is wanting, the angles and the closing of the work must be altogether relied on, as they constitute a sufficient proof of themselves.

## SECTION VI.

### TO RANGE LINES AND TAKE BEARINGS IN EXTENSIVE SURVEYS.

Before a single line can be measured with the chain or the angle which one line makes with another, taken with the theodolite, the three station poles that determine the triangle must be set, and as it is the direction of the lines that determines the measure of the angles, and, on the contrary, the measure of the angles that gives the direction of the line (cor. 28), it follows that the slightest deviation in either will mar the trigonometrical relation that exists

between them, so that the subsequent work of plotting cannot be performed with geometrical accuracy. In Constructive Geometry triangles have to be made, but in Trigonometry they are presumed to exist, and their sides and angles to have a definite relation to each other.

In every survey the first work is to set the poles at the principal stations, and thus determine the triangles of the trigonometrical survey, and to fix upon the main line, which should be measured with the chain before the taking of the bearings with the theodolite commences. This is done by the surveyor going over the ground, and either setting the poles or marking the best places for the stations.

Between the principal stations intervening poles require to be ranged afterwards, before the lines can be accurately measured with the chain. When the lines are long, this is generally done with the aid of a telescope only; but when sight is obstructed the theodolite may be necessary. Thus in the annexed diagram the stations A and B are not seen from each other; consequently, before the two in-

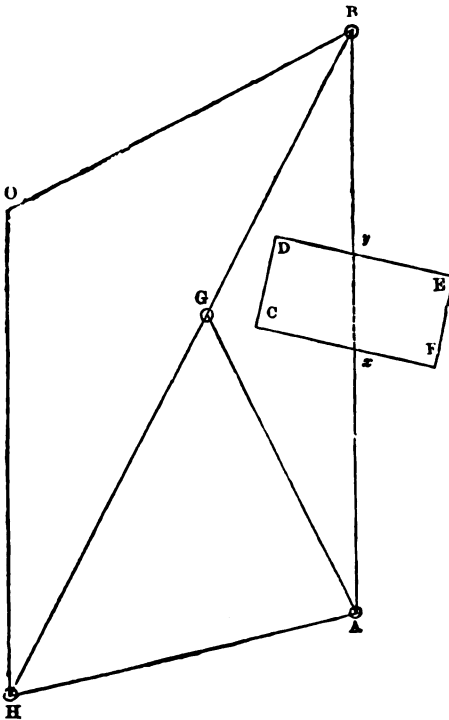

tervening station poles  $x$  and  $y$  can be ranged so as to enable those in charge of the chain to measure the line, the angles A and B must first be determined, which is done in taking the bearings. An example will best illustrate this.

Ex. To range and measure a line between two stations when sight is obstructed by a town, village, farm-homestead, plantation, or other impediment.

Let A and B be the two stations, CDEF the obstruction to sight, and AB the line sought.

Take any third station G visible from A

and B. Then measure AG and GB with the chain, and take the angle G with the theodolite. Having thus found two sides and the in-

cluded angle, the other two angles and side may be got by Case III. Part VIII. Sect. III.

When the line *AB* has to be measured with the chain as is generally the case, find the angles *A* and *B* as before, and then either range  $+x$  and  $+y$  with the theodolite, or by Problem XXII. Part I. This done, the line may be measured with the chain by Problem XII. Part III.

In extensive surveys the bearings should be kept well in advance, in order not to give any hindrance to that division of the staff in charge of both chain and field-book on their arrival at stations such as *A* and *B* in the above example. And besides expediting the work, it is also in favour of accuracy; for when the principal lines, with the exception of the base line, are first determined by trigonometry, it serves as a check upon the measurement with the chain.

The principal stations should also be so organised that the bearings taken at them shall be a proof-check upon each other.

This is done by making each flagstaff visible from as many of the other principal stations on the survey as possible, so that the total area is thus twice taken, and the position of things several times determined.

In surveying thickly-wooded parks, game-preserves, deer-forests, and large plantations covering hundreds and even thousands of acres, it is often necessary to place station poles in any open grounds most convenient, and to take the bearings of such from other stations on elevated places at a distance. Such auxiliary stations are not unfrequently upon the estates of adjoining proprietors, whose leave must necessarily be obtained before field operations commence. Sometimes the smoke that issues from the chimneys of the shooting-box of the sportsman, or of the cottage of his gamekeeper, is the only thing that indicates their respective sites. In such cases a flagstaff may have to be fixed on the top of a tree. In other examples the chimney-tops may be visible from some elevated ground, and thus serve the purpose of flagstaffs.

On mountainous estates—as in some parts of Wales, north of England, and greater part of Scotland—a station pole on the top of a hill can seldom be seen from any part of the valley below, owing to the height and curvature of the former, and narrowness of the latter. In such cases the principal station poles will require to be placed at proper distances along the brows of the two opposite mountains, although only one of them may be included in the survey. The two sets of station poles on the opposite hills should be visible from as many of the stations on the open grounds of the valley as possible. Towards the top of the mountain being surveyed, other

station poles may then be placed, visible from those on its brow farther down.

There are three principal reasons for placing station poles on opposite mountain-sides, as above directed, that require to be noticed.

*First.* The line between two flagstaves, one on the brow of each hill, right and left, forms an office or plotting check, the bearings of the two being taken from a station in the valley below, and also the bearings of the stations in the valley from the two elevated ones above on each side.

*Second.* Lines along the brow of a hill can frequently be measured with the chain when those in the valley cannot, owing to lakes, rivers, or growing timber, being in the way.

*Third.* The bearings of stations on the opposite mountain, both above and below its brow, can be taken, and the various conspicuous objects thus laid down upon the plan in their true position—such as a lake, a waterfall, meanderings of a river, bridges, rocks, roads, residences, particular outstanding trees, &c.

In a campaign country, the station poles in the valleys may, with few exceptions, be seen from those on the tops of hills; but owing to the greater number of the latter, it is often advisable to continue the direction of lines rectilineally over them. This may be done by means of poles, but more easily by the theodolite placed on the top of the hill. In preliminary surveys taken with the telescope for the purpose of determining the best places for the stations of the trigonometrical survey, straight lines may thus be produced over hills, by simply laying down the offset-staff in the proper direction both ways, and then by directing the telescope first from the one end of the offset-staff, and then from the other, along its length. An approximation of the bearings may at the same time be taken by a protractor and the shadow of a staff, or by a pocket compass.

The work of taking the bearings commences first at the one end of the main line and then at the other. Thus, if we suppose BH in the diagram a main line and that at +B the bearings of O from H are first taken; then in going along the line to H, the angle AGH would be taken in passing, which would also give AGB. At H the angle BHO would be taken. The telescope would then be turned back again to B, and next round from B to A, in order to find the angle GHA, which, with AGH previously found, would give GAH.

The line BH, and consequently BG and GH, having been previously measured with the chain, the necessary trigonometrical data are now given to find the remaining parts of the three angles BOH, BGA, and AGH. Thus BH and the three angles are given

to find  $BO$  and  $HO$ ;  $GH$  and the three angles to find  $AG$  and  $AH$ ; and  $AG$  and  $GB$  and the included angle  $AGB$  to find  $AB$  and the angles  $ABG$  and  $BAG$ .

In a similar manner all the sides and angles of the several triangles into which the survey may be divided are found. At every station there are always two lines ranging from it, more frequently three and four; and sometimes when the flagstaff occupies a central position, as at  $O$  in the diagram Section IV., a great many. And as the work proceeds, the readings from the compass and measure of the angles, horizontal and vertical, from the theodolite, are carefully recorded in the field-book in their respective columns; one for the horizontal angles, one for the vertical when taken, one for the compass, and the two outside spaces for remarks, &c., as usual.

In large surveys, the calculations and plottings should never be allowed to fall behind, as many things are liable to escape the memory that cannot be entered in the field-books. And besides this, it is necessary that the triangles be plotted to test their own accuracy, as well as that of the measurement with the chain.

With the exception of the main line, the chain should follow the theodolite. This is not an absolute rule, but one of expediency, which will be found for the most part advisable to observe.

When the details within the large triangles are left to be worked up in the office, those in charge of the field-book cannot be too careful to avoid omissions as to the proximate measure of angles not taken by the theodolite, and the range of lines not driven by the chain, that determine the species of the triangles and the ratios of their sides, otherwise they may fall into what is termed "the ambiguous case" already noticed (Section II. Part VIII.) In other words, when in the field they should take a note of the trigonometrical relationship of the sides and angles of the triangles to each other, more especially as to whether the sines are those of acute or obtuse angles, and whether the diameter includes that portion of it in which the centre of the circle lies (Art. 34, Part VIII. Section II.)

Omissions of the above kind are only experienced in plotting, which proves that they belong to Constructive Geometry, and not to Trigonometry or the mensuration of superficies, as formerly shown. To beginners, anxious to get quickly over the ground, such omissions are by no means unfrequent misfortunes. It must be borne in mind, however, that no ambiguity exists in the field, for there lines and angles bear a closer resemblance to the definition given them than do those of the office and class-room. If therefore, in driving the line  $AC$  (fig. 2, Section II. Part VIII.), it is omitted to enter in the field-book that the sine of  $C$  is within the triangle, and in driving

AC (fig. 3) that the sine of C is that of an obtuse angle, and consequently falls upon the diameter BCD, produced without the triangle, then ambiguity in the office is the natural concomitant of such an omission. And this, too, does not represent the full amount of negligence in the field, for in driving either of the two lines from C, the staff are proceeding to a definite point of the compass, one too far asunder from that of the other line to be mistaken for it.

The professional objection of surveyors to treating the ambiguous case as a proposition, either in trigonometry or the mensuration of superficies, is perhaps the most convincing proof that it belongs exclusively to Constructive Geometry. Thus, if admitted into the former, a triangular field would contain either the one or the other of two measures, either the area within the triangle ABC (Example II. Part VIII.), or that within ABC (Example 3); consequently two plans would be required, a greater and a less, for which payment would assuredly be received for neither. Hence the practical conclusion.

In field operations it is always preferable to determine either the three angles and one side or two sides of a triangle, or else two sides and the included angle. But this cannot always be complied with, and the following general rules will assist beginners in making provision for the exception, as by Article 34, Section II. Part VIII.

1. When the sum of the adjacent or opposite angles is equal to a right angle, the other angle is also a right angle.
2. When the sum of the two angles adjacent to any one of the given sides is less than a right angle, the other angle opposite that side is obtuse.
3. When the sum of the two angles adjacent to any one of the two given sides is greater than a right angle, the other angle opposite that side is acute.
4. When the angle included by the two given sides is obtuse, then the other two angles of the triangle are acute.
5. When the complement of the given angle is greater than the angle included by the two given sides, the other remaining angle is obtuse.
6. When the complement of the given angle is less than the angle included by the two given sides, the remaining angle is acute.
7. The nearer the angle opposite the given angle is to a right angle, the greater is the liability to error, in taking approximate estimates of angles.

## SECTION VII.

## TO SURVEY WITH THE CIRCUMFERENTOR.

The circumferentor is sometimes used in surveying. It consists of a flat bar of brass *BB*, about fifteen inches long, with sights *CC* at its opposite ends, and two narrow slits *b*, *c* for taking observations; in the middle of the bar is a circular brass box *A*, containing a magnetic needle, which, as usual, is covered with glass. The ends of the needle play over a brass circle *g*, which is divided into  $360^\circ$  in such a manner that the two quadrant *s* are at right angles to the line drawn through the sights. The instrument is usually supported on a tripod *E*, and can be turned in any direction by means of its socket-joint. When the magnetic needle is properly balanced, and moves freely in its horizontal position, it will retain its position of magnetic north, while the sights are turned from one station to another; consequently the number of degrees which the angle contains can be read off. The great length of the magnetic needle increases the accuracy of the circumferentor, for, if it were short, and consequently the graduations on the brass circle proportionately small, the angle could not be read off with sufficient accuracy.

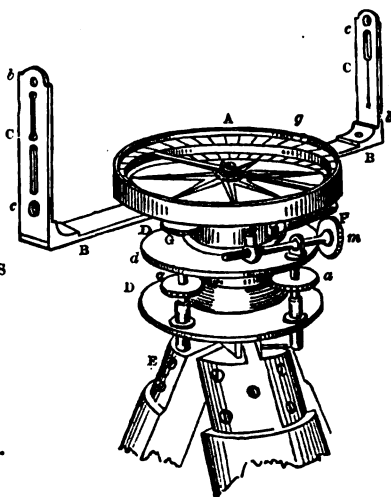

The instrument is chiefly used in surveying mines, coal-pits, woods, &c.

The circumferentor is sometimes provided with a spirit-level *F*, with adjusting screws *a*, *a*, &c., a tangent screw *m*, a vernier, &c., in which case it may be made to answer most of the purposes of a theodolite.

The needle should not be suffered to play longer than necessary, but be lifted off its centre, otherwise the delicate point on which it turns would soon be destroyed. The instrument usually has the east and west marked contrary to their true positions, in order that by the reading of the needle the actual direction of the line is shown.



*To find the bearing of an object by the circumferentor.*

Place the circumferentor over the station, turn N. sight to the object, and looking through the S. sight adjust with the tangent-screw till the hair in the N. sight exactly cuts the object—this part of the operation being the same as in the theodolite. When the needle has perfectly settled, read off the degrees to which its N. end points, from the N. or S. line of the compass-box, accordingly as the N. or S. end of the needle is in the N. or S. part of the compass-box; the angle thus read off is called the bearing of the object.

If the needle stand between two degrees, as between  $40^{\circ}$  and  $41^{\circ}$  turn the instrument gently till it stand exactly at  $40^{\circ}$ , and clamp it; detach the sights, and bring them with the vernier, with which they are connected, carefully back to the object: the number of minutes to be added to the angle will be shown by the first coincidence of a division on the vernier with one on the horizontal plate; if the coincidence take place at the 27 division, the angle will be  $40^{\circ} 27'$ .

The method of taking an angle with this instrument without using the needle, is the same as with the theodolite.

*On plotting the bearings taken by the circumferentor, &c.*

In laying down the bearings, in cases where the angles are taken from the magnetic meridian of the circumferentor, that meridian is first drawn on the plan, and from a point in it the bearing of the first line from it is laid off with the protractor; the length of the line is next laid off, and through its extremity another meridian is drawn parallel to the former; the second bearing, and the length of the second line, are then laid off in the same manner; and so on till the work be completed, and the variation of the compass being known, the true meridian may then be drawn on the plan, that the work may have its proper position on the finished plan.

The above method is the same as that of laying down a wood, or road survey, by the theodolite, except in laying off the angles.

When the angles are taken with the circumferentor without reference to the magnetic needle, the method of laying down the work is the same as in theodolite surveying.

**NOTE.** In coal-mines, when a pit or shaft is required to be sunk from the surface to a given point in the works below, it is usual to take the several bearings and distances with this instrument, from the bottom of an existing shaft along the passages in the mine, to the required point; and then to repeat the same operation on the surface of the ground, without plotting the work on paper; by which means complete accuracy is frequently obtained.

## RAILWAY SURVEYING.

A complete survey for an intended railway contains six problems, three of which are field operations, and the remainder office work. They are as follows :—

Prob. I. To range the station poles that form the chain and other lines.

Prob. II. To measure with the chain the chain lines ; with the theodolite the angles which they form, also the angles of depression, to obtain data for the reduction of the hypotenusal planes of the earth's surface to a common plane ; and with levelling instruments to take the levels of stations.

The field notes under this problem are in three field-books ; the first for the chain, the second for the theodolite, and the third for the levelling instruments.

Prob. III. Given the field notes, to plot the plan and sections.

Prob. IV. To apportion the land required for the intended railway.

Prob. V. To find the field notes required for setting out the railway estate and the line, including the diversion of roads, &c.

Prob. VI. To set out the railway estate and line, including roads, &c., whose diversion is necessary.

In a preliminary survey, and in a parliamentary survey, and also in surveying a railway which passes through an estate being surveyed, only a portion of the above field and office operations are required.

In the following directions for a preliminary survey, the lines are ranged for laying down the railway from a series of connected base-lines. It is seldom, however, that lines thus ranged can be measured by the chain with sufficient accuracy, and when such is the case, even ground adjacent must be selected for base-lines, so as to obtain the true lengths of the former by trigonometry.

Another method is to range the right lines of the projected railway, and either to join them by the conveying tangents from the two tangential station-poles, or else by the chord-line that lies between them (the two tangential stations), and then to take the bearings of these stations from the adjacent base-stations, so as to find their reduced distances or base-lengths required for plotting ; and when an adjacent base-line is not perfectly level, its hypotenusal length must be reduced to base-measure, otherwise the field notes, both for plotting and setting out the railway, will be erroneous. (See ADVERTISEMENT, p. viii., under RAILWAY SURVEYING.)

*Illustrated general directions for a preliminary survey of a portion of a projected railway.*

Landowners (resident and absentee), the executors of minors, mortgagees, and capitalists, often order plans purposely to ascertain how far projected railways will interfere with their respective interests involved, and whether they would be justified in farther supporting such projects.

Plans of this kind are of the simplest character, consistent with the purpose they are intended to serve. The several resident agents in charge of estates proposed to be intersected watch such railway movements closely, and never fail to apply to their employers for instructions how to act. They are often by profession land-surveyors themselves, and, when such, they send to their absent employers a sketch of the projected line on tracing-paper, taken from the plans of their estates; or when otherwise, they employ their surveyors to do so for them, who may give a general sketch of the whole intended line upon an ordnance map.

Again, several parties may join and order a survey and plan of the whole district through which the projected railway is intended to pass, or only of that portion of it in which they are more immediately interested.

The annexed figure, already referred to, may be presumed to represent a plan of this latter kind. It is, in point of fact, a copy of a plan of a portion of a district surveyed for the purpose of the projected railway RST, the base-line AC being ranged so as to avoid Lynch Wood. This line terminates at +C, partly on account of its diverging too far from the line of the railway, and partly to avoid the River Ouse beyond +C. The next base-line commences at +B in AC, and runs close to the railway at T. Beyond +D (on the complete survey of the whole line) it continues the same direction till its deviation requires another base-line.

*To range the base-lines.*

The initiatory step in such a survey is to range the base-lines. This is done by going over the ground and carefully examining it from points where the projected railway may be presumed to be on a level with the surface. Such points are generally determined by the amount of excavation, on the one hand, that is required to fill up the hollows on the other. An experienced eye will approximate very closely to such data. Having come to a definite conclusion on these points, and the curvature to which they may give rise, the flagstaves are then set so as to avoid obstructions, and be visible from each

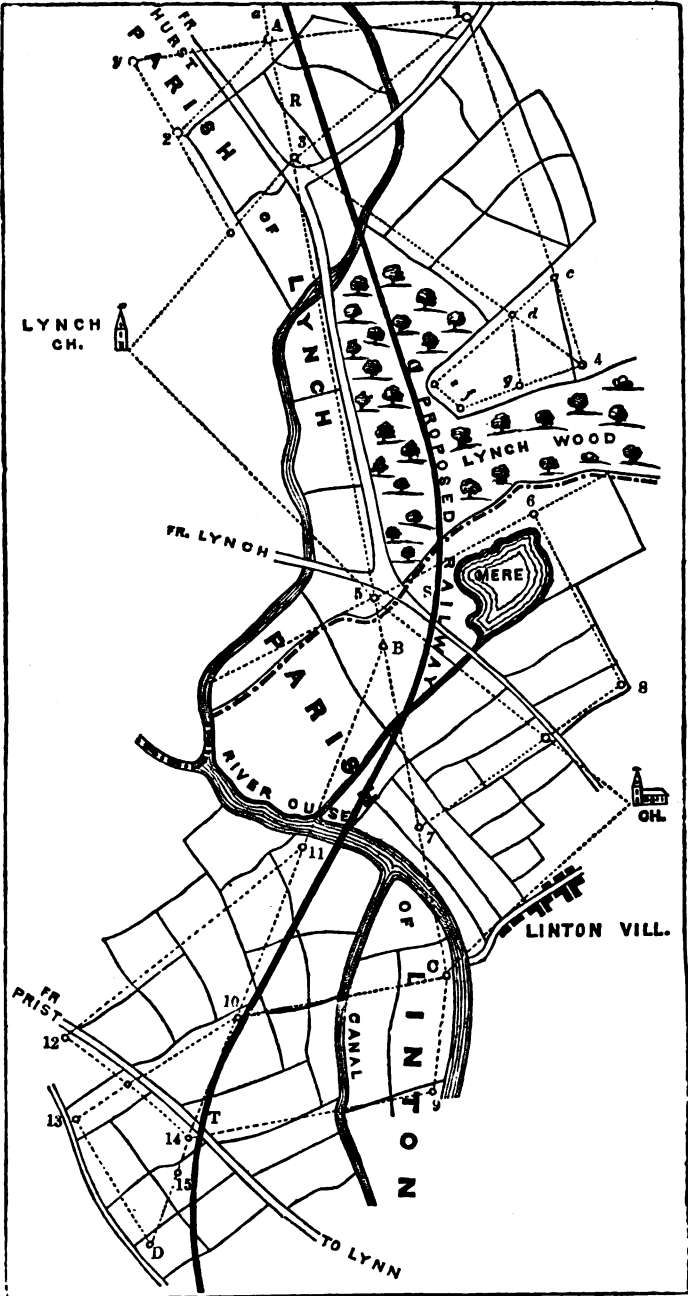

other. Such flagstuffs then constitute the principal stations in the survey, the lines which they make being base-lines.

The several base-lines are denominated first, second, third, &c. The numbers run from the point where the survey commences, and each base-line should embrace as great a length of the projected railway as is consistent with details. In the figure there are only two base-lines in the survey, AC being the *first base-line* and BD the *second base-line*.

*To lay down the base-lines, and draw the projected railway upon an ordnance or other map.*

Having fixed flagstuffs at the principal stations A, C, B, and D, the next work is to find out the points to represent those stations upon an ordnance map (or any other map thought preferable). This done, the projected line is then drawn upon the map with a steady hand, its direction being subject to any deviation which the details of the survey may suggest.

*To range the secondary and minor lines.*

Before placing the station poles that determine the secondary and minor lines, and that enable the surveyor to take bearings, he must first make himself thoroughly acquainted with the boundaries of estates, counties, and parishes, in order to ascertain how far the projected line will interfere with private and public interests. This is a work often surrounded with much difficulty, interest being not unfrequently concealed at this stage, and when doubts exist an increased number of station poles may be advisable so as to get fences, roads, and other objects faithfully delineated, purposely to avoid objections to the accuracy of the plan.

The ranging of the secondary and minor lines on each side of the base-lines, and the setting of the station poles, are similar in railway surveying to what they are in an ordinary survey of several adjoining estates. For the details of the work, we may, therefore, refer back to previous sections. For such data, ordnance maps are seldom or never to be relied upon. The bearings of old church steeples and like prominent objects may be correct, but it is for the most part otherwise with the areas and positions of fields, and the innumerable little things upon which interested parties place a value—things that require to be shown upon the plan—some of which may not have existed at the time of the ordnance survey; consequently all details should be carefully laid down from an actual survey. In the example, the different stations on each side of the base-lines, and the secondary and minor lines which they make, will be seen

upon the drawing or plan, and the plotting data they involve understood.

The distance on either side of the projected railway that requires to be surveyed is invariably specified in the order or agreement. It generally considerably exceeds the parliamentary requirements subsequently given and illustrated in Plate XIII., by "limits of deviation," and may extend from 30 chains to a mile. Thus in the figure it extends to Lynch Church on the one side, and to Linton Church on the other, both of which serve as stations.

The reason of this extra breadth, as compared with the parliamentary limits, is to make ample provision for deviation, and to include the interests of all parties that may be affected, in order to induce them to come forward, and either support or oppose the projected railway as circumstances may direct.

*To take bearings and measure the first base-line AC.*

When the surveying staff employed is large, it may be divided as in land-surveying; one party or division taking the theodolite, and the other the chain. But when it is small, the taking of the bearings and measuring with the chain proceed together, an extra labourer being employed to carry the theodolite when the latter work is being prosecuted between stations. This conjunct method is that which the present example illustrates, the chain and theodolite going together, the staff being undivided.

The work commences at station A, and in a complete survey of the whole length of a projected railway, the bearings of the first base-line should be taken from a meridian, as in land-surveying. But when a portion of such a survey is only called for, the bearing of the first base-line may be taken from that of the base-line immediately preceding it on that side, provided station A is in it. If the contrary is the case, as it generally is, two or three other methods may be adopted. *First*, the base-line AC may be produced to the auxiliary station *a*, and the bearings at station A taken from it. *Second*, the bearings at A may be taken from C. *Third*, the bearings at A may be taken from station 1, the line *y* 1 thus serving as a meridian.

The first and second of these methods are identically the same, although differing in the details indicated. In point of fact, the line CA*a* is only a portion of a base-line which the learner may presume has either been ranged from a meridian or from another base-line for had the plan represented the survey of the whole length of the projected railway, then the line CA would have extended beyond A in the direction *Aa* until its divergence from the railway called for

another base-line; and we may further observe that, in a similar manner, the base BD would have proceeded till its deviation called for a base-line on that side, which may be taken as the *third base-line*, to range from station 15, in the same manner as the second base-line ranges from B on the first base-line.

From these observations, the learner will readily perceive how the total number of base-lines in a complete survey of the whole length of a projected railway may be ranged from a meridian, and their positions accurately delineated upon a plan. He will also be able to comprehend the proper relation that exists between the survey of a part and of the whole.

According to the above data, the range of the base-line AC with the meridian may be considered as having been previously taken. The bearings at A, therefore, commence either from the auxiliary station *a*, by the first method, or +1 by the third method. The former is the more accurate of the two methods, as it gives the whole of the details required for rectilinear and angular proof; for if the reading at C is  $180^\circ$ , the line CA*a* is correct, and if the sum of the angles at A is 360, the whole of the bearings are true, as will be seen below. The readings of the bearings may be entered in the field-book thus:—

From <i>a</i>	231° 40'	to +2
in AC produced	180°	to +C
	90° 40'	to +1
Begin	at +A	

The several angles at A are now found and read thus:—

<i>a</i> A1	=	90° 40'	
1AC	=	89° 20'	180
CA2	=	51° 40'	
2Ay	=	39°	
<i>y</i> A <i>a</i>	=	89° 20'	180
Proof	360		360

The bearings at A being taken, the work of measuring with the chain commences from that station to station 3. At +3 the instrument is then placed, and the bearings from +A to +1, from +1 to +4, at the north-eastern boundary of Lynch Wood, from +4 to +C, and from +C to +Lynch Church, are each taken and entered in the field-book, as were the bearings at +A. The part of the base-line between +3 and +5 is next driven, the River Ouse being crossed by the bridge on the road from Hurst to Linton, that portion of the line across the river being measured according to Problem XII., Part III. At +5 the bearings are taken from +3 to +6

to get the southern boundary of Lynch Wood, the northern boundary of Linton Mere, and the boundary between the two parishes shown by dotted lines, from + 6 to Linton Church, from Linton Church to + c, and from + c to Lynch Church; also from Lynch Church to + 3 as a check upon the last angle, so as to determine accurately the position of the church. When the ground is undulating, checks of this kind should never be omitted. The measurement now proceeds to +7, where an angle is taken to +8, the line passing over that from +5 to Linton Church, a minor station pole being placed at the crossing of the two lines. The remaining portion of the first base-line is then driven, viz., from +7 to +c, the distance across the River Ouse being measured by any of the methods given under Problem I. Part VIII. At c the bearings to Linton Church, and to stations 9 and 10, are taken, which conclude the work on the first base-line.

*To take bearings and measure the second base-line BD.*

The staff now go back to B, and from that station take the bearing from + c to + D, which determines the range of BD. The first portion of the line, viz., from +B to +11, is then measured, the distance across the River Ouse being found, as before, where the first base-line crosses near Linton. The measuring of the remaining portions of the line, and the taking of the bearings at the several stations upon it, may advantageously be left for the learner to conclude as an exercise.

*Details of the survey.*

The measuring of the secondary and minor lines, the taking of the offsets, and the whole of the remaining portion of the work, with the exception of levelling, and reporting on the probable amount of damages along the projected line, is so exactly similar to land-surveying, that the more advisable course in an educational work of this kind is to leave it to be performed by the student. Such, when taken in detail, forms very suitable exercises, and by this time he must be considered qualified to go through the whole successfully.

With regard to levelling and reporting, all that is generally demanded of the surveyor, relative to the former, in a preliminary survey, is to take some points in the projected railway presumed to be on a level, or in the same horizontal plane with the surface of the ground, or nearly so, the difference between water-level lines and horizontal being nominal, and from these stations to take the angles of elevation and depression, so as to be able to give an approximate estimate of how much land it will occupy. On the



severance of fields, the diversion of roads, water-courses, and other encroachments of this kind, the surveyor may report. But land-owners and their agents, when once they get the plans, generally go over the ground along with their tenants and satisfy themselves in such points, and for the most part they are by no means strangers during the survey at the several station-flags.

---

## PART X.

### RAILWAY ENGINEERING.

#### SECTION I.

##### LEVELLING.

LEVELLING is the art of representing the inequalities of the upper boundary of any section of the earth's surface, and of determining the relative heights of any number of points in that boundary, above or below a line equidistant, at every point, from the earth's centre. This line is termed a level line,\* and is that which water assumes when at rest.

The operation of levelling may be performed by various instruments, depending on the action of gravity: the most simple of which are those formed with a *plumb line*, such as the ordinary mason's level; but these are only suited for very limited operations.

The fluid or *water-level* consists principally of a glass tube, bent like the letter U, open at both ends, and partly filled with water; the surfaces of which, in the two arms of the tube, will stand at the same level by the action of gravity; and a line of sight taken over these two surfaces is therefore a level line. This instrument has been much improved, but, in all its modifications, it is found inconvenient in practice.

There are also the reflecting and cambrian levels, which are useful only for special operations of small extent, such as military engineering, &c.

(1.) The instrument used for levelling by civil engineers is called a spirit-level, or simply, a level.

##### DESCRIPTION OF THE Y LEVEL.

(2.) This instrument consists of a portion of a theodolite brought to its utmost practical perfection, and constructed for levelling

\* What is here termed a level line, is, in reality, a great circle of the earth, a small arc of which, on account of the great magnitude of its radius, may be considered as a straight and level line.

purposes only; its chief parts are the telescope AA with the spirit-level DD beneath it, and two parallel plates with four conjugate screws K, K, &c., between them; to the lower of these plates are fixed the legs that support the instrument; and on the upper one rests a pillar that supports a strong brass plate GG, in which is fixed the compass H. This plate supports the telescope by means of two pillars F, F, called Y's from their forked shape, and

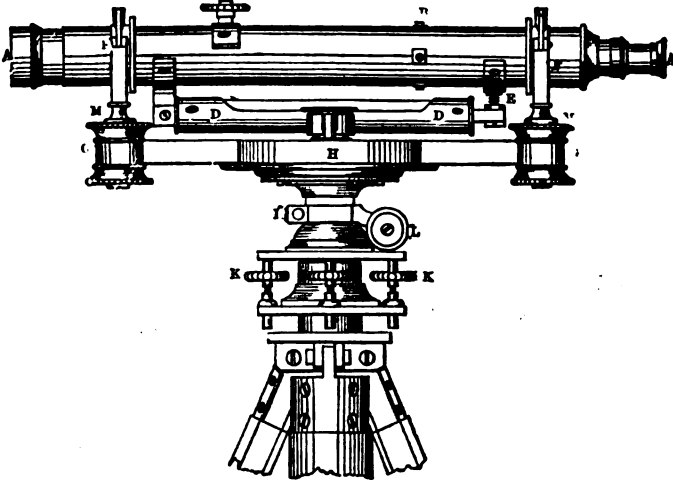

from which the instrument has its name. The telescope is provided with a screw C, to adjust the object-glass, and four other screws to adjust the cross wires within it. The spirit-level is adjusted by the screw E, having a joint at the other end. The instrument is clamped by the screw I, and brought accurately into the required line by the tangent screw L.

#### ADJUSTMENTS.

(3.) *There are three adjustments of the level; firstly, that of the line of collimation of the telescope; secondly, that of the axis of the level of the axis of the telescope; thirdly, that to make the telescope always at right angles to the vertical axis of the instrument.*

The two first adjustments are the same as those for the theodolite, which see: the last is as follows.

Having fixed the instrument on the ground as nearly level as can be judged by the eye, set the telescope over either pair of conjugate screws K, K, &c.; by means of which bring the bubble to the middle of the level tube; turn the telescope over the other pair of conjugate screws, and correct the level; turn it back to the other pair, and correct again, if necessary. Then reverse the direction of the tele-

scope over either or both pairs of screws, alternately backwards and forwards; and if the bubble be found to stand in the middle in all directions, the instrument is then in adjustment; if not, the error arises from the axis of the level not being perpendicular to the vertical axis of the instrument. To correct this error, raise or depress the movable support of the telescope by the milled-headed screw beneath, till the bubble be brought half-way to the middle of the tube; then correct for the other half by the conjugate screws; repeating the correction till perfect accuracy is obtained.

**NOTE.**—This adjustment is the same in all levels. The other adjustments are either different in different levels, or not required from the nature of their construction.

#### TROUGHTON'S IMPROVED LEVEL.

(4.) This level is preferred by many, on account of its adjustments not being so liable, after they are once perfected, to derangement. The spirit-level is placed above the telescope, and over it the compass-box. In most instruments the telescope shows the object

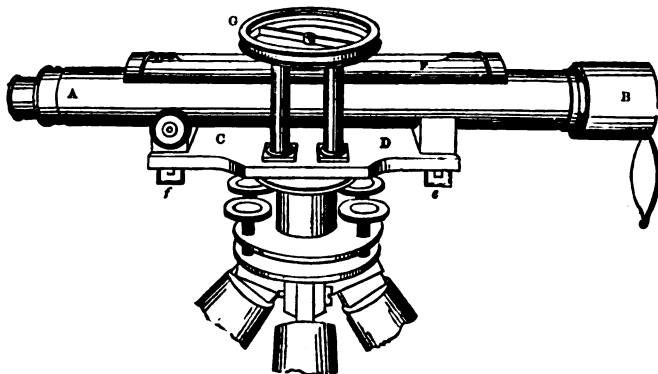

inverted. The spirit-level is firmly fixed in its cell, and the adjustment of its axis with that of the telescope, or line of collimation, is given by two screws near the eye-glass.

#### GRAVATT'S LEVEL.

(5.) This level is another modification of the preceding one; it is usually called the *Dumpy*, from the comparative shortness of its telescope. It has an object-glass of larger aperture, and shorter focal length; its spirit-level, as in the preceding one, is fixed above the telescope; it has also a small mirror so fixed on a hinge that the position of the air-bubble can be seen by the observer while he reads off the staff.

Many varieties of levels are used by engineers; but the dif-

ferences in construction are generally only slight. It is important to have one made by a good maker, or much trouble may be caused in its use. The telescope should be short and of large diameter, and *it should always reverse the image*, by which much light is gained. The reversal of the figures is only a little perplexing at first; it is very soon learnt, and no one who has been accustomed to a reversing level would willingly change to an upright one.

LEVELLING STAVES.

(6.) These staves are generally from twelve to fourteen feet in length, but made to slide telescopically into about one-third of this length for portability. They are divided into feet, and again into tenths of a foot; and, lastly, subdivided into hundredths of a foot. The feet are marked by large figures—the tenths by smaller ones.

There are several varieties of staves sold by instrument-makers.

CORRECTION FOR CURVATURE.

(7.) Let BDEH be a line of sight as given by a level, *i.e.*, a horizontal line; BCFG an arc of a great circle of the earth, and A its centre. It will be seen from the figure that the heights DC, EF, HG, of the apparent level BH, above the true level, continually increase from the point B. The height DC of the apparent level above the true, is nearly equal to the square of the distance BD, divided by twice the earth's radius AB, that

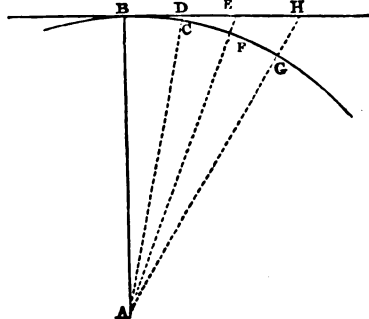

is,  $DC = \frac{BD^2}{2AB}$ . Similarly  $EF = \frac{BE^2}{2AB}$  &c.; therefore the corrections DC, EF, &c., are always proportional to the squares of the distances BD, BE, &c., seeing that  $2AB$  is a constant quantity. By substituting the value of  $\frac{1}{2AB}$  in miles, chains, &c., in the formula  $DC = \frac{BD^2}{2AB}$ , the rules for finding the corrections are derived.

Suppose the diameter of the earth to be 7958 miles, and that the distance BC = 1 mile, then the correction for curvature  $DC = \frac{BC^2}{2AB} = \frac{1^2}{7958} = \frac{1}{7958}$  of a mile = 7.962 inches = nearly 8 inches. If the distance BE = 2 miles, then the correction  $EF = \frac{BE^2}{2AB} = \frac{2^2}{7958} = \frac{4}{7958}$  of a mile = 31.848 inches.

The correction for curvature may be approximately found for any distance by the following practical rules :—

*When the distance is in miles.*

Rule I.—Take  $\frac{1}{8}$  of the square of the distance in miles for the correction in feet.

*When the distance is in chains.*

Rule II.—Take  $\frac{1}{8}$  of the square of the distance in chains, from which cut off two places for decimals, for the correction in inches.

*When the distance is in yards.*

Rule III.—Multiply the square of the distance in yards by .0000257, for the correction in inches.

#### CORRECTION FOR REFRACTION.

(8.) The refraction varies according to the state of the atmosphere, but it may generally be taken at  $\frac{1}{8}$  of the correction for curvature as an average; and since refraction makes objects appear higher than they really are, the correction for it must be deducted from that for curvature.

*Examples.*

1. Required the correction for curvature and refraction, when the distance of the object is  $2\frac{1}{4}$  miles.

$$\begin{aligned} \text{Here } (2\frac{1}{4})^2 \times \frac{2}{3} &= \left(\frac{9}{4}\right)^2 \times \frac{2}{3} = \frac{27}{8} = 3.375 \text{ feet, cor. for curvature} \\ \frac{1}{8} \text{ of which} &= \frac{.482}{2.893} \text{ ——— cor. for refraction} \\ & \qquad \qquad \qquad 2.893 \text{ ——— cor. required.} \end{aligned}$$

2. Required the correction, for curvature and refraction, when the distance is 40 chains.

$$\begin{aligned} \text{Here } 40^2 \div 800 &= 2 \text{ inches, correction for curvature} \\ \frac{1}{8} \text{ of which} &= \frac{.285}{1.715} \text{ ——— cor. for refraction} \\ & \qquad \qquad \qquad 1.715 \text{ ——— cor. required.} \end{aligned}$$

3. Required the correction, as in the last examples, when the distance of the object is 1000 yards.

$$\begin{aligned} \text{Here } 1050^2 \times .0000257 &= 2.57 \text{ inches, cor. for curvature} \\ \frac{1}{8} \text{ of which} &= \frac{.367}{2.203} \text{ ——— cor. for refraction} \\ & \qquad \qquad \qquad 2.203 \text{ ——— cor. required.} \end{aligned}$$

NOTE.—These corrections, it will be seen, are very small at short distances, and are frequently obviated in practical levelling. See Note to Art. 11.

## THE PRACTICE OF LEVELLING.

(9.) *To find the differences of the levels of several points on the earth's surface, and to trace a sectional line of them.*

Let A, B, C, D, E, be the points on the earth's surface, a sectional line of which is required to be traced. Set up the levelling staves

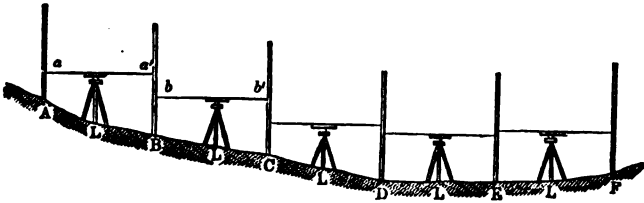

perpendicularly at A and B; between which fix the level L on the ground; make the spirit-level horizontal, and turn the object-glass of the telescope to the back-staff A; then the staff A is cut at  $a$  by the horizontal line of sight  $aa'$  of the telescope, through which the observer can read off the height  $aa$ . Now turn the object-glass of the telescope to the staff B, the horizontal line of sight  $aa'$  cutting it at  $a'$ , and read off the height  $Ba'$ : then the difference between the heights  $Ba'$ ,  $Aa$ , is the number of feet that B is lower than A, because the line  $aa'$  is horizontal. Now let the staff A be removed to C, the staff B remaining in the same position, excepting that its graduated side must now be turned towards C, and having removed the level L, place it between B and C, and the spirit-level being again made horizontal, the line of sight, in this case, being  $bb'$ , read off the heights  $Bb$ ,  $Cb'$  the difference of which is the number of feet that C is lower than B, as before.

In this manner, by alternately moving the levelling staves, placing the level between them, and reading off the heights below the line of sight or collimation, the operation is conducted to F.

Now, as there is a continued fall from A to D, the sum of the differences of the readings at B and A, at C and B, and at D and C, will give the actual fall *vertically* from A to D; in the same way the rise from D to F is estimated: if, therefore, the fall from A to D be greater than the rise from D to F, the difference of these two will be the *actual* fall from AF, or the distance in feet, estimated *vertically*, that the station A is higher than the station F.

## EXAMPLE.

	Feet	Feet	
Let the readings on the staves A and B be	{ 3·50 } { 7·57 }		4·07 diff.
on B and C	{ 5·04 } { 7·39 }		2·35 „
on C and D	{ 4·04 } { 7·00 }		2·96 „
			9·38 sum.

	Feet	Feet	
The reading on the staves D and E	{ 6·10 } { 5·93 }		0·17 diff.
on E and F	{ 6·81 } { 4·86 }		1·95 „
Total rise from D to F . . .			2·12 sum.
Actual fall from A to F . . .			7·26 diff.

The difference of the sums of the back and front readings of the staves, or "back and fore sights," as they are termed, will also give the difference between A and F: thus—

Back Sight	Fore Sight	
3·50	7·57	
5·04	7·39	
4·04	7·00	
6·10	7·93	
6·81	7·86	
25·49	32·75 sum of fore sights	
	25·49 sum of back sights	
	7·36 diff. the same as before.	

But in order to draw the section to show the undulations of the ground between A and F, the *horizontal* distances of the several points B, C, D, E, and F, must be measured from the first station A; this is usually done with the chain during the operation of levelling. These distances with the back and fore sights may be arranged in a Field-Book of the following form, which, though not the practical form, may probably be better understood by the student.

FIELD BOOK.

Back Sight.	Fore Sight.	Fall.	Rise.	Reduced Levels below Station A.	Distances.
3·50	7·57	4·07		4·07 at B	Chains. 6·00
5·04	7·39	2·35		6·42 „ C	12·00
4·04	7·00	2·96		9·38 „ D	18·00
6·10	5·93		0·17	9·21 „ E	24·00
6·81	4·86		1·95	7·26 „ F	30·00
25·49	32·75				
	25·49				
7·26 diff. the same as the last of the reduced levels					

In the above Field-Book it will be seen that the differences 4·07 and 2·35 in the column marked Fall are added together, making 6·42 for the fall at C, in the column of reduced levels: to this sum the next difference 2·96 is added for the fall at D. The other differences, in the column marked Rise, are successively subtracted from the last sum 9·38 for the falls at E and F: the latter of which, agreeing with the other difference, shows the accuracy of the castings. The last column shows the horizontal distances of the several points B, C, &c., from A.

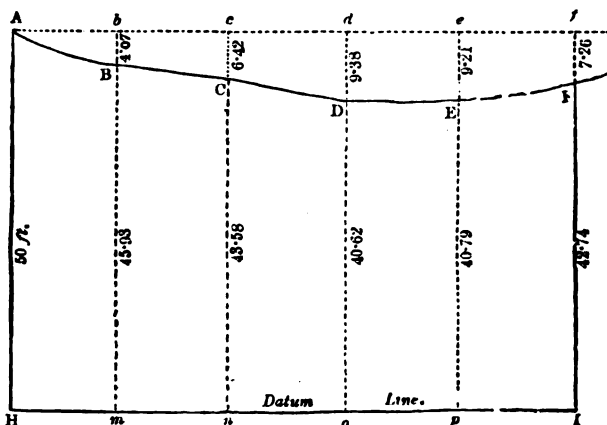

In plotting from the above columns of reduced levels and distances, the former are always taken from a larger scale than the latter,



otherwise the variations in the ground would, in a great many cases be scarcely perceptible; the horizontal scale used in plotting the following section is 10 chains to an inch, and the vertical one for the reduced levels 25 feet to an inch, which latter scale has been thus chosen, that the section may be the same as that in the figure to Article 9, the vertical scale practically used being commonly 50 or 100 feet to an inch.

Having drawn the horizontal line  $Af$ , set off the distances  $Ab = 6$  chains,  $Ac = 12$  chains, &c., from the column of distances, on a scale of 10 chains to an inch; then set off the vertical lines  $bB$ ,  $cC$ , &c., respectively, 4.07 feet, 6.42 feet, &c., from the column of reduced levels, on a scale of 25 feet to an inch, and through the points  $A$ ,  $B$ ,  $C$ , &c., draw the line  $ABCDEF$ , which is the section required.

#### THE DATUM-LINE.

(10.) It is found inconvenient in practice to plot a section generally by the method already given, as the reduced levels, in extensive operations, would alternately rise and fall above and below  $Af$  (see last figure), and thus produce much confusion: therefore, a line  $HI$ , called a datum line, is assumed at 50, 100, or 200 feet, &c., below the first station  $A$ , so that it may be always *below* the sectional line  $ABCDEF$ . To or from this assumed distance of the datum line the rise or fall is respectively added or subtracted, and the next rise or fall added to or subtracted from the sum or difference, as in the following Level-Book; thus giving a series of vertical heights to be set off, always upwards from the datum line, through the upper extremities of which the section line is to be drawn.

#### PRACTICAL LEVEL-BOOK.

*Datum line 50 feet below station A.*

Back Sight.	Fore Sight.	Rise.	Fall.	Reduced Levels.	Dist.	Remarks.
				50.00 D.		
3.50	7.57	- -	4.07	45.93	6.00	B. M. at A.
5.04	7.39	- -	2.35	43.58	12.00	
4.04	7.00	- -	2.96	40.62	18.00	
6.10	5.93	0.17	- -	40.79	24.00	
6.81	4.86	1.95	- -	42.74	30.00	
25.49	32.75	2.12	9.38	50.00		
	25.49		2.12			
	7.26 differences =		7.26	7.26	{ diff. between last red. level and datum	

Having set off the distances on the datum line HI, draw the vertical lines HA, mB, nC, oD, pE, and IF, setting off their heights as in the column of *reduced levels*, and through the points A, B, &c., draw the required section ABCDEF.

(11.) It will be seen that the operation of levelling is extremely simple, as are also the castings of the Level-Book, and the plotting of the section. Great care is, however, necessary in reading off the staves, which ought, at the same time, to be held in a perfectly upright position; *the castings in the Level-Book ought also to be carefully checked by taking the respective differences of the sums of the back and fore sights, and of the sums of the rises and falls, also of the datum number and the last reduced level; which three differences must agree, as shown in the preceding Level-Book, otherwise errors will be found in extensive operations to creep in imperceptibly.*

NOTE.—Calculations to find the corrections for curvature and refraction are sometimes necessary in levelling, but as these would be extremely tedious, especially in extensive operations, they may be obviated by fixing the level always half-way between the staves, *as nearly as the eye can judge*, and thus the errors in both become equal and opposite, and consequently correct each other.

The general practice of levelling being now laid down in a brief manner, more details shall next be given.

#### TRIAL-LEVELS.

(12.) The general direction or route of a proposed line of railway between two places being determined upon, the line is marked out on such a map or plan of the district or country as is most convenient. (For this purpose the ordnance maps are the best, if the line be in England or Ireland.)

The levels are then taken, as near as possible to the direction thus marked out on the map; if any deviations are made from the projected line, they are confined to the intervals between where it crosses turnpikes and other public roads, the relative heights of the points where it crosses these roads being always determined; also marks, usually called *bench marks* (abbreviated B. M.), are made in or near them, these marks being described in the Level-Book for future reference. Cross-levels are also frequently taken, especially on the roads, to show the inclination of the ground to the right and left of the line, so that the engineer may know how to improve the line, and prepare it for further operations.

If the line, thus obtained, be thought not satisfactory, other directions, embracing either the whole, or only part of the distance between the two places, are tried in the same manner, and that direction which includes the fewest engineering difficulties is adopted.

## CHECK-LEVELS AND SURVEY OF THE LINE.

(13.) Check-levels are sometimes taken to ascertain the accuracy of the trial-levels, if any doubt exist in this respect, and more especially if the line be a detached one; *i.e.*, not connected at its commencement or termination with existing lines, nor anywhere intersecting them. This, however, can rarely be the case in these times, when so many railways exist, the sections of which are published, and from and to which almost [all new lines proceed. Hence the elevations of the commencement or termination of almost all new operations are so well known, not only with respect to these points, but also to other intermediate points of intersection with existing lines, as to obviate the use of check-levels, provided the trial-levels have been taken by a careful leveller.

(14.) The trial-levels, being considered satisfactory, the survey of the surface is immediately commenced to the width of from 5 to 10 or 15 chains on each side of the projected line, accordingly as the property of individuals may appear to be affected, or the engineering difficulties or requirements of the line may demand. This survey must include every enclosure, building, road, &c., within the above-named limits; it is usually on a scale of from 5 to 10 chains to an inch. It is in every respect the same as in the preliminary survey, Section I., to which reference is given for the details of the work.

## FINAL LEVELS.

(15.) The point of commencement of the proposed railway being determined upon by the previous operations, set one of the levelling staves on that point and call it the first back station, and select a point as near this station as possible, the height and position of which must be entered in the Level-Book as a mark of reference for future operations. This is called a *bench mark*; it is marked B. M. in the column of remarks in the Level-Book; it may be either between the first back station and the second, or between the second and third, accordingly as convenient objects for the purpose present themselves. The most proper places for bench marks are prominent stones on buildings, or other fixed stones, hinges of gates, mile-stones, notches near the roots of trees, &c., the positions of which must be described in the Level-Book. Fix the level firmly in the ground about half-way between the first and second stations, and make the axis of the spirit-level horizontal in all positions; read off the staff at the first back station; this reading is placed in the first column of the Level-Book, marked *Back Sights*. If neither the

bench mark nor any other intermediate point requiring notice, occur between the two stations, turn the telescope to the second station and read off the height ; this reading is placed in the third column of the Level-Book, marked *Fore Sights*. Remove the first staff to the bench mark, or intermediate station (if one occur), having at the time removed the instrument ; read off the back sight and enter it in the Level-Book, as before ; then read off the staff on the bench mark, and enter the reading in the column marked *Inter.* ; lastly, read off the forestaff, as before : thus continuing and taking as many bench marks, and other intermediate sights, as may be thought necessary ; the chaining of the line proceeding at the same time, the results of which are placed in the column of distances. It will readily be seen that four assistants will be required by the leveller, *i.e.*, two for the staves and two for the chaining. (For method of keeping Level-Book, see next page.)

From this Level-Book the method of proceeding, to any extent, may be sufficiently seen, with the help of the following remarks on the method of obtaining the reduced levels, at the same time.

NOTE.—That wheresoever the back or fore sight exceeds the usual height of the levelling staff, that staff must be understood to have been placed on the top of a gate or rail-post, and its height afterwards measured, and added to the reading of the levelling-staff.

(16.) *Remarks on obtaining the reduced levels, &c., in the following Level-Book, &c.*

The method of casting the Level-Book referred to, is the same, with respect to the back and fore sights, as that given in Art. 10, page 353. These castings must be first done, and the intermediate ones, in the column marked *Inter.*, afterwards.

The datum line is assumed 100 feet below the first station or commencement of the levels : this number is placed first in the column of reduced levels. The back sight is 2·20 feet, and its corresponding fore sight 13·40, which shows that the ground falls ; the difference of these 11·20, is put in the column marked *Fall*, which, being subtracted from the datum 100 feet leaves \* 88·80, which is put under the datum, in the column marked *Reduced Levels*, being marked with an asterisk or cross, and shows the height of the fore-staff above the datum line. The same remarks will apply to the back and fore sights 1·80 and 10·10, and to 7·30 and 1·80, observing that in the latter case the ground rises, and the difference must be put in the column marked *Rise*, and added to the next preceding reduced level that is marked thus\*.

## LEVEL-BOOK.

*The projected railway from the Grand Junction Railway to Abbergelley. (See Section, Plate XIII.)*

Back Sights.	Inter.	Fore Sights.	Rise.	Fall.	Reduced Levels.	Distances in Chains.	Remarks.
			Datum	...	Ft. 100.00		Below level of rails of the Grand Junction Railway, at its junction therewith.
On Rail	} 10-16	13-40		11-20	*88.80	0.45	On side of railway embankment.
2.20					8.36	80.44	0.80
1.80		10-10		8.30	*80.50	3.00	Edge of drain (3 ft. deep).
	7.70			0.40	80.10	5.00	
	4.80		2.50		83.00	7.00	
	4.60		2.70		83.20	10.00	Occupation road to Elm farm and Wingfield cottages.
		1.80	5.50		*86.00	11.10	At foot of perpendicular bank  2 ft. high.
							At top of ditto.
12.00	10.00		2.00		88.00	11.13	
	5.00		7.00		93.00	15.00	
		0.00	12.00		*98.00	17.00	
14.00	12.20		1.80		99.80	20.00	Centre of open occupation road to Hill farm.
		2.00	12.00		*110.00	23.86	
							On Bank top.
7.86	3.80		4.06		114.06	24.20	B. M. on flat square stone at corner of Hill farm barn, 1 ch. to left.
	2.20		5.66		115.66		
		0.00	7.86		*117.86	26.50	
	5.00		2.20		120.06	28.00	
		2.00	5.20		*123.06	} 32.00	Foot-path.
					100.00		
52.36		29.30			23.06		
29.30							
23.06							

The difference between the first back sight 1.80, and the first intermediate one 10.16, is 8.36, which shows that the ground falls; it is therefore put in the column of falls, under 11.20, and subtracted from the next preceding number in the column of reduced levels, marked thus \*, and the remainder 80.44 is then put in that column. In like

LEVEL-BOOK—*continued.*

Back Sights.	Inter.	Fore Sights.	Rise.	Fall.	Reduced Levels.	Distances in Chains.	Remarks
					Ft. *123.06		
9.83		8.89	0.94		*124.00	32.60	
13.50	8.50		5.00		129.00	33.00	In plantation.
		1.40	12.10		*136.10	35.00	Ditto.
10.60	4.70		5.90		142.00	37.00	Ditto.
	1.70		8.90		145.00	39.00	15 links over planta- tion hedge, on edge of bank of road to Westwick.
	6.70		3.90		140.00	39.40	Centre of road to Westwick.
		2.60	8.00		*144.10	40.00	On further bank of ditto. B. M. on square stone in line.
1.05	9.15			8.10	136.00	43.00	
		15.65		14.60	*129.50	45.20	
1.00	6.00			5.00	124.50	46.80	Crosses foot-path to Westwick.
		13.50		12.50	*117.00	47.50	Edge of steep brow.
0.40	3.90			3.50	113.50	48.00	
		17.40		17.00	*100.00	49.00	
1.60	11.60			10.00	90.00	50.20	Bottom of brow.
		14.50		12.90	*87.10	51.15	Edge of brook.
5.00	14.00			9.00	78.10	51.65	Centre of do. (water 2 ft. deep).
		0.00	5.00		*92.10	52.00	Further bank of brook.
12.00		0.10	11.90		*104.00	53.50	
14.00		2.50	11.50		*115.50	55.45	
15.00	8.50		6.50		122.00	56.10	
		0.00	15.00		*130.50	56.95	
10.00		1.70	8.80		*138.80	58.75	Foot-path to farm- house.
15.00	5.80		9.20		148.00	59.80	
		0.40	14.60		*153.40	60.65	
14.20		0.60	13.60		*167.00	61.60	
12.00	8.00		4.00		171.00	62.25	Centre of public road to Winston, road 50 links wide.
		1.00	11.00		*178.00	63.40	
135.18		80.24			123.06		
80.24					54.94		
54.94							

manner all intermediate differences are added to, or subtracted from, the next preceding reduced level number marked thus\*, accordingly as they stand in the column marked Rise or Fall.

The proof of the accuracy of the work is by taking the differences of the sums of the back and fore sights, and of the first and last

reduced levels, which differences must be equal ; thus, in the latter portion of the Level-Book, the sums of the back and fore sights are 135·18 and 80·24, the difference of which is 54·94 ; and the first and last reduced levels are 123·06 and 178·00, the difference of which is also 54·94, which shows the work to be right.

(17.) As a means of checking the accuracy of trial-levels it has sometimes been recommended to employ two levellers, with separate instruments placed at a short distance from one another, to read from the same staves at the same time, and frequently to compare their reduced levels, correcting the errors immediately, if any occur ; this would completely obviate the numerous mistakes that arise, in extensive operations, through wrong readings, wrong entries in the Level-Book, &c. ; since the method of proving the Level-Book by differences only proves that the reduced levels are correct with respect to the back and fore sights entered in the book, and not the accuracy of the actual levels.

#### PLOTTING THE MAIN SECTION.

(18.) First draw the datum line, as in Plate XIII. ; and from a scale of 5 chains to an inch lay off the  $\frac{1}{4}$ ,  $\frac{1}{2}$ ,  $\frac{3}{4}$ , and 1 mile distances, repeating them after every successive mile, and marking the miles 1, 2, 3, &c. Now lay off on the datum line, from the column of distances in the Level-Book, the several distances up to the first mile ; do the same between the second and third line, between the third and fourth, &c., the distances always beginning afresh from the end of every mile in the Level-Book. Draw lines perpendicular to the datum line at the end of every mile, and parallel to these perpendiculars draw lines in pencil of the height given in the column of reduced levels, and at their corresponding distances, from a scale of 50 feet to an inch ; and through the upper extremities of these lines draw the section, carefully noting the roads, paths, rivers, brooks, woods, &c., as given in the column of remarks in the Level-Books, which, it will be seen, are copied in the plate.

#### CROSS LEVELS.

(19.) Cross levels are taken principally on roads crossed by the line of railway, to show the position of the surface of the ground, partly with a view, if possible, of improving the main line, and partly to show the nature of the approaches of the cross roads to the bridges, where required, and the quantity in respect to depth and length of cutting, or of height and length of embankment required where the main line is crossed either over or under by bridges, or on the line of the rails.

The heights in the cross-section are usually taken at every chain's length, to the distance of 10 chains on each side of the line, as will be seen in the following notes; remembering always to take the levels *from the left to the right* of the onward direction of the main line, otherwise serious errors might arise by plotting the section in the wrong direction.

The cross-section is usually plotted on the same scale as the main section; some engineers adopt a larger one. The student can have no difficulty in plotting from the following notes. (See Plate XIII., Cross-Section No. 3.)

*Cross levels No. 3. on road from Winston to Mold.*

Back Sights	Inter.	Fore Sights	Distance.	Remarks.
1·13			0·00	
	1·86		1·00	
	2·89		2·00	
	6·70		4·00	
	8·83		5·00	
1·02		10·64	6·00	
	7·70		8·00	
2·83		10·76	9·00	
	6·60		10·00	
	7·31		10·31	Line crosses. Reduced level 104 feet
0·61		9·55	11·00	
0·48		8·32	13·00	
0·65		8·40	15·00	
1·63			17·00	
	6·70		19·00	
		8·06	20·00	

(20.) THE APPLICATION OF THE CORRECTION FOR CURVATURE AND REFRACTION IN LEVELLING.

In the preceding examples on levelling, the application of the correction for curvature and refraction has been avoided, by assuming that the levelling instrument was always placed in observing at or near the middle point between the staves; thus making the errors arising from these causes correct each other. (See note to Art. 11.) But in a case where a very long sight is taken in one direction, as, for instance, the fore sight, the back sight at the same time being a very short one, these corrections must be strictly attended to, as in the following

*Example.*—In taking levels for a projected railway, a swamp of 148 chains in width occurred in the line; the level was placed at the



edge of the swamp, the back-staff was placed one chain behind the instrument, on the level of the swamp, the reading thereon being 5·56 feet; the level being reversed, was found to cut a notch in a post, standing nearly in the line, on the opposite edge of the swamp, and on going round the swamp to the post, and measuring the height of the notch thereon, it was found to be 7·36 feet above the level of the swamp; required the correction for curvature and refraction.

By Art. 8, Rule II.  $(148)^2 \div 800 = 27\cdot38$  inches = cor. for cur.  
deduct  $\frac{1}{4} = 3\cdot91$  ————— for ref.

Correction for curvature and ref. =  $23\cdot47 = 1\cdot95$  feet.

Therefore  $7\cdot36 - 1\cdot95 = 5\cdot41$  feet, is the corrected fore sight; the back sight, being at so short a distance, needs no correction: hence the difference of the levels of the edges of the swamp is  $5\cdot56 - 5\cdot41 = 0\cdot15$  feet.

NOTE.—From the above example it will be seen that had the correction not been made, the error in the levels would have been nearly 2 feet.

(21.) When several assistants are employed on the same section, a uniform system should be strictly adopted, and the superintendent of the work should fix upon the bench marks, occasionally checking the work of the others. When a section has been thus taken in several parts at the same time, after putting the parts carefully together, a common datum line must be assumed for them all, and the result checked by adding or subtracting the differences of the reduced levels at the points of junction, accordingly as they rise or fall.

Intermediate sights, in ordinary levelling, need only be taken to tenths of feet, as it would be a waste of time to attempt greater accuracy, excepting where the levels are taken to bench marks, in which the same accuracy should be observed as in taking back and fore sights. The height of the optical axis of the level, when on the line, or the level of the line of section, may always be put down as an intermediate sight, if required. It will here be proper to observe that it is not necessary that the levelling instrument should be placed directly on the sectional line, while making observations therewith, but in any convenient position either to the right or left of it.

In taking levels through towns, the operation frequently proceeds in a zigzag direction, such as the streets may present, the length of the required sectional line being determined from a map of the town, and the several heights of the points in the section obtained from the reduced levels, corresponding to the points in the streets where the sectional line crosses them. In a similar manner the elevation of the extreme points of the estates of proprietors and occupiers, who are hostile to engineering operations, are obtained by going round

without the bounds of their premises, or by the nearest roads between the extreme points, the profile of the intermediate space being assumed.

NOTE.—All the methods of levelling, and of laying down sections therefrom, given in the preceding articles of this section, will apply to canals, roads, sewers, drains, &c., with the same facility as if they had been written for these purposes.

#### LEVELLING BY THE THEODOLITE.

(22.) When the levels are required to be taken over very high and rapidly rising summits, on the acclivities and declivities of which it is found very difficult to fix the levelling instrument, or over steep and almost perpendicular cliffs, where it cannot be fixed at all, the operation would be best performed by the theodolite, which must be set perfectly level, both with respect to the spirit-levels on their vernier plate, and that which is attached to the telescope; and the angles of elevation and depression of the required points, both before and behind the instrument, respectively, taken by means of the vertical arc; the distances on the slope of the observed points from the instrument being, at the same time, measured as correctly as circumstances may permit, from which *data* the perpendicular elevation and depression of the points, as well as their horizontal distances from the instrument, may be found by the rules of right-angled plane trigonometry. These operations may be repeated for any number of stations, recollecting to make the necessary corrections for curvature and refraction, and to take into account the heights of the instrument and of the objects placed in the observed points. Operations of this kind should be performed when the atmosphere is settled, otherwise the refraction will be found so extremely variable and deceptive as to produce considerable error.

#### LEVELLING BY THE ANEROID BAROMETER.

It is often very useful, in going over a line of country, to be able to form a general approximate idea of the levels or altitudes of the ground, without going to the trouble of levelling it in the usual way. For this purpose the aneroid barometer (which is now made small enough for the pocket) is admirably adapted, as it will indicate differences of altitude to a few feet with tolerable precision. Full directions for the use of the instrument are usually sold with it.

It must, however, be borne in mind that the pressure of the atmosphere, even in the same place, is constantly varying, and that therefore, unless this source of error is provided against, the indications of the barometer may be exceedingly delusive. If accurate indications are desired, a duplicate instrument, remaining stationary

in one place, should be constantly watched and registered during the survey, and its indications carefully compared with that carried about over the ground.

## SECTION II.

### PARLIAMENTARY PLAN AND SECTION, ETC.

(23.) When application is made to Parliament for authority to make a railway, it is necessary to prepare a survey of the intended line, showing both its horizontal and vertical position; the documents exhibiting these features being called the "Parliamentary Plan and Section." Copies of these and some other documents have to be *deposited*, in due form, at certain places, in compliance with certain rules established by Parliament for the purpose.

These rules are called the "Standing Orders of the Houses of Lords and Commons on Private Bills." They contain many directions not only for the preparation of the plans and sections, but also for the laying out of the lines, all which must be carefully adhered to by the engineer and surveyor, or he will risk the rejection of his Bill. The standing orders are altered and amended from time to time, and it is therefore highly necessary that any engineer who contemplates going to Parliament, should provide himself with a copy of the latest edition, which is sold by Parliamentary stationers at a moderate price.

According to the standing orders of 1863, the *Plan* must be drawn to a scale of not less than *four inches to a mile*, and where any buildings are included within the limits of deviation, enlarged plans must be given to a scale not less than  $\frac{1}{4}$  of an inch to 100 feet.

The *Section* must be drawn to the same *horizontal* scale as the plan, and to a *vertical* scale of not less than 1 inch to every 100 feet. The line of the railway shown is to correspond with the upper surface of the rails.

A model plan and section usually accompany the published book of standing orders.

*Method of preparing a plan and section of a railway, as required by the standing orders of the House of Commons, preparatory to obtaining an Act of Parliament for its construction.*

Plate XIII. is a portion of a plan and section, with cross-sections &c., of a railway prepared for the above-named purpose. The plan or map of a portion of the country through which it passes occupies the lower portion of the plate, the proposed centre line of the railway being marked thereon by a strong black line, and by dots where

it passes through a tunnel. The fields, &c., in the parish where the railway commences are numbered consecutively to the boundary of the next parish, where the numbers commence afresh, and so on through the successive parishes or townships; the numbers referring to corresponding numbers in a book of reference, in which are descriptions of the several properties, with the names of owners and occupiers. On each side of the centre line, and parallel to it, at the distance of 100 yards, or 454 links from it, are dotted lines called the *limits of deviation*: within the space included by these dotted lines, the engineer, on being empowered to construct the railway, is allowed to deviate from the line, as projected on the map, should he think it advisable for the sake of improving the line, or of avoiding expensive severance &c.

The main section, with its accompanying cross-sections, occupies the upper portions of the plate (these sections are the same as those referred to in some of the preceding articles), to prepare which, for Parliamentary as well as practical purposes, it will be first necessary to explain the method of laying out gradients.

#### THE METHOD OF LAYING OUT GRADIENTS.

(24.) The gradient of any portion of a railway means the inclination of the surface of the rails with respect to a horizontal line. A level line of railway would, doubtless, be preferable to any other; but the unevenness of the earth's surface puts this out of the question in by far the greatest number of railways. It is well to make the gradients as flat as possible, consistent with economy in construction of the works; they were formerly limited to about 1 in 264, but owing to the improvements in the tractive power, they now frequently reach 1 in 100, beyond which they should not go except in very difficult cases. Parliamentary committees exercise a rigid investigation into the necessity of steep gradients in lines brought before them.

The usual practical method of laying out railway gradients is by applying one end of an extended silken thread to the commencement of the railway on the section, the other end being so applied that the extended thread may cut the curved boundary of the section or profile of the earth's surface, so as to leave an equal portion of space both above and below the thread, as nearly as can be judged by the eye, in order that the cuttings from the spaces or parts of the section above the thread, may produce materials sufficient to fill up the spaces or parts below the thread, or form the embankments of the railway. The position of the thread being thought satisfactory for the purposes required, its extremities are

marked, and a line ruled in the place occupied by it for the first gradient. The second, third, &c., gradients are laid out in a similar manner to the end of the section. See Art. 26 and the two following notes.

NOTE 1.—The excavations and embankments of a railway are made about 2 feet lower than the level of the rails, thus giving a line parallel thereto, called the *balance or formation line*; the 2 feet filled up with gravel, to form the road and the beds for the sleepers of the rails.

2. If the position of the first gradient, though favourable in itself, cause the following gradient, or gradients, to be less favourable, with respect to the quantity of cuttings and embankments, it is advisable to alter the position of the first gradient to one less favourable, provided that the compound results of cuttings and embankments on the several successive gradients, as now altered, is more favourable than in the preceding case. In this manner, it is requisite to change the positions of the several gradients repeatedly till the *minimum*, or least possible quantity of cuttings and embankments, shall be required in the construction of the railway, keeping in view the required limit in the ascent and descent of the several gradients; the difficulty of making the excavations, throughout the whole length of the line, being supposed, at the same time, to be nearly equal. But where the geological character of the country through which the railway passes, differs considerably, presenting for excavation strata varying throughout the length of the line from loose sand to hard rock, and *vice versa*, the facility or difficulty of making the excavations must be carefully considered in laying out the gradients; larger excavations being advisable where they can be easily made—and smaller where with difficulty. *The least possible expense will be incurred in the construction of a railway by taking into account all these circumstances.*

(25.) If anywhere in the section the excavations reach 60 feet in depth, and afterwards increase rapidly in depth, it is a more economical method of proceeding to make a subterraneous passage, called a *tunnel*, through the deep part, than to cut the whole open to the surface of the ground, which in many cases would be next to impossible. Tunnels are cut to the width and depth of 30 feet, for railways on the narrow gauge; if on the broad gauge, to the width and depth of 36 and 32 feet respectively, the width and depth being less in both cases, if the material to be cut be hard rock. The diminished quantity of cuttings, where tunnels occur, must be taken into account in laying out the gradients.

(26.) *To determine the rate of inclination of a gradient.*

AB, in Plate XIII., is the first gradient on the railway section, the cuttings or excavations above it being considered to be equal to the requirements of the embankments below it: at its commencement A, its height AO is 100 feet; and at its termination B, its height BC is 130 feet above the datum line; thus giving a rise of 130—100

= 30 feet ; the horizontal length OC of the gradient is 65·60 chains = 4329·6 feet. There is, therefore, a vertical rise of 30 feet in a horizontal distance of 4329·6 : hence  $30 : 4329·6 :: 1 : 144·32$  ; or, in round numbers, a rise of 1 in 144, which is called the inclination of the gradient AB, and is thus noted on the section, **INCLINATION 1 IN 144.**

*The rule for finding the rate of inclination of a gradient may be thus briefly enunciated :—*

Multiply the horizontal length of the gradient in chains by 66, and divide the product by the difference of the heights of the gradient at its extremities, above the datum line, and the quotient is the horizontal distance to a rise of 1 foot, or the rate of inclination required.

(27.) The excavations at B being about 60 feet deep, and continuing to increase rapidly, a tunnel BD, to the length of 462 yards, is introduced on the next following gradient ; the tunnel having passed beyond the summit, till its depth at D again becomes 60 feet ; its height, as shown on the section, is 21 feet, being the height to which the cuttings are reduced by the ballasting below and the arch above. The gradient, of which the tunnel forms a part, is assumed to extend beyond the limits of the plate ; its position, therefore, is not determined by the excavations and embankments shown thereon, but in conjunction with those beyond its limits.

(28.) *Method of determining the heights of the several roads passed over or under by the railway, and whether they should be raised or lowered to give sufficient height for viaducts or bridges ; or to be raised or lowered to be passed on the level of the railway.*

When a road is passed over by the railway, the usual height allowed from the surface of the road to that of the rails is 18 or 20 feet ; and when the road is passed under by the railway, the height allowed is 18 or 19 feet.

The heights or depths of the roads, rivers, &c., above or below the rails, or gradients, is sometimes found by measuring them carefully by the vertical scale ; but they may be found more accurately by the following method :—

The distance of the middle of the first road from the commencement of the section is 10 chains, its height above the datum lines is 83·20 feet, the horizontal length OC of the first gradient is 65·60 chains, and the gradient rises  $130 - 100 = 30$  feet. There is, therefore, given the length and rise of the gradient to find its rise at any other given point ; which may be done by similar triangles ; thus—

As hor. length of gradient 65·60 ch. : 30 ft. : : 10 ch. the dist. of road : 4·57 ft., the rise of the gradient at  $a$ ; this added to 100 ft., the height of the gradient at  $A$ , gives 104·57 ft., the height of the point  $a$  above the datum line; but the height of the road above the same line is 83·20 feet, therefore  $104·57 - 83·20 = 21·37$  ft. = 21 ft. 4 in. is the height of the rails at  $a$  above the road; which, being above 20 ft., shows that the level of the road may remain unaltered, the height of the bridge required for the railway being 18 ft.; thus leaving 3 ft. 4 in. for the thickness of the arch and ballasting, and its span being taken 24 ft., as being sufficient to allow carriages to pass one another on the road below the line.

The distance of the occupation road per Level-Book, is 24·06 ch., and the reduced level is 110 ft., therefore 65·60 ch. : 30 ft. : : 24·06 ch. : 10·91 ft.; hence

$$100 + 10·91 = 110·91 \text{ ft. height of gradient at road}$$

$$\frac{110·00 \text{ ft. do. of road}}{0·91 \text{ ft. 11 inches, the height the road must}}$$

be raised to be passed over on level of rails. In raising or lowering roads for this purpose, a rise or fall of 1 foot in 20 is required.

In the same manner, the road from Westbrook to Hurst is found to be 22 feet above the gradient; the hedge of the brook that forms the boundary of the parishes of Westbrook and Winston, 36 ft. 5 in. below the gradient; and the road next following, 40 ft. 5 in. above it.

## SECTION III.

### RAILWAY CURVES.

#### (1.) *On the use of curves in railways in general.*

The use of curves in railways is absolutely necessary on account of the natural unevenness of the earth's surface, it being desirable to attain the nearest possible practical level by avoiding hills, crags, mountains, &c., and by winding round them by means of curves. Curves are also equally necessary in avoiding other natural and artificial obstructions, in many cases not materially affecting the level of the line, as lakes, swamps, the windings of sea-coasts, and of rivers; also cities, towns, villages, parks, pleasure-grounds, &c. In this manner a great saving is effected in the expense of extensive excavations, embankments, tunnels, viaducts, &c., as well as the expense of the severance of valuable property, which would otherwise be required. Besides, it is frequently desirable to make a

winding railway, in order that it may embrace in its route some important city, town, harbour, &c., or make a junction with another railway. Straight lines in railways are, however, much to be preferred to curves, and are therefore adopted as far as possible; they are first set out as bases for further operations; and every curve is subordinate to two straight portions of the line, which are tangents to it at its commencement and termination. The curves adopted in practice are always arcs of circles. Sometimes two, three, or more consecutive circular arcs, having a common tangent at their point or points of junction, are joined together, as in the case of the compound curve; and sometimes two circular arcs are connected, having their convexities turned different ways, with a common tangent at their point of junction, as in the case of the serpentine, or S curve.

NOTE.—Other curves beside the circular arc might sometimes with advantage be adopted as the curves of railways; but their construction is attended with difficulty.

(2.) *On mechanical railway curves, or curve-rulers.*

Mechanical railway curves, sometimes called curve-rulers, are a series of segments of circles made of hard wood, as box or mahogany, or strong paste-board, with their radii in inches marked on them. These curves

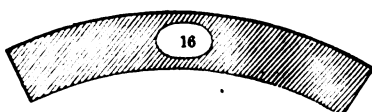

commonly begin with a radius of  $2\frac{1}{2}$  inches, and terminate with one of 160 inches, or upwards; the smallest radii usually increased by  $\frac{1}{2}$  inch up to 10 inches; then by inches up to 20 inches; afterwards by 2 inches up to 80, including all numbers ending in 5; lastly, by 5 inches, till near the end of the series, when the radii increase by 10 inches.

The annexed figure represents the railway curve-ruler of 16 inches radius. If the scale of plan, to which this curve-ruler is applied be 5 chains to an inch, it will represent a curve or circular arc of  $16 \times 5 = 80$  chains = 1 mile radius. If the scale of the plan be 12 chains to an inch, it will represent an arc of  $16 \times 12 = 192$  chains = 2 miles and  $3\frac{1}{4}$  furlongs radius; and similarly for other scales.

(3.) *The limit of the radii of railway curves.*

As a general rule the curves of a railway should be kept of as large a radius as possible consistently with the economical laying-out of the line. One mile radius or upwards is quite unobjectionable; but half-a-mile, or even less, will be sanctioned by Parliament



in difficult cases, particularly near large stations, where the speed is usually slackened. In all sharp curves the outer rail requires to be raised above the level of the inner one, to counteract the effect of the centrifugal force. (See Formulæ in Section VII.)

### PROBLEM I.

#### CASE I.

*To determine the radius of a railway curve mechanically, that is, by the curve-rulers; the positions of the straight or tangential portions of the railway being given.*

This problem admits of an indefinite number of solutions, but the curve adopted is generally that which falls on ground presenting the fewest natural or artificial obstructions, provided its radius be not too great. (See Art. 3.)

Let AB, CD be two straight portions of a railway, the positions of which are given by an accurate plan; and which, when prolonged, meet at T. Apply several of the series of curve-rulers (see Art. 2) to touch the line AB, without cutting it, at the points B, B', B'', &c., and also to touch CD, in like manner, at the points C, C', C'', &c.; and let BC, BC', BC'', &c., be the curves thus obtained. Then whichever of these curves may appear, on a careful consideration, to be least obstructed by hills, lakes, rivers, buildings, &c., must be adopted as part of the line of railway, provided its radius be equal to, or exceed, the required limit. The radius is determined by multiplying the number on the curve-ruler by the number of chains per inch on the scale of the plan.

*Example.* If the curve BC be drawn by the curve-ruler, numbered 22, and be adopted as part of the line, and the scale of the plan be 5 chains to an inch, required the radius of the curve.

$22 \times 5 = 110$  chains = 1 mile 3 fur., the radius required.

**NOTE.**—By this method the radii of railway curves are commonly found in practice; but since a circular arc of large radius apparently coincides with its

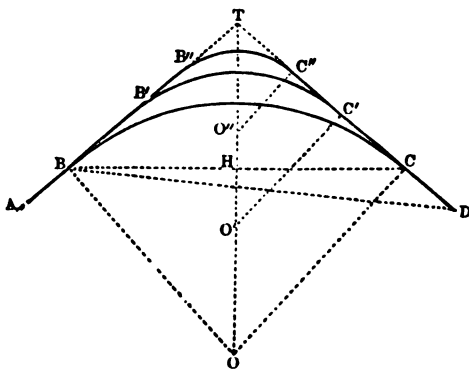

tangent for a considerable distance, it is difficult, in this manner, to determine the exact starting-points of the curve; besides, if the plan be not strictly accurate, as is too often the case, the positions of the tangents cannot be said to be given, and therefore this method should only be employed in roughly determining the radius and starting-points of the curve, so that it may fall, in its progress, on the most favourable ground.

## CASE II.

*To determine the radius of a railway curve geometrically, the starting-point B being given.*

Prolong AB, DC till they meet at T; bisect the angle ATD by the line TO; and at B draw BO perpendicular to AT, meeting TO in O. Then O is the centre, and BO the required radius of the curve BC.

Or,

Make TC = TB; and draw the perpendiculars BO, CO, meeting in O. Then BO, or CO, is the radius of the curve.

In the same manner, the other radii C'O', C''O'', &c., of the curves B'C', B''C'', &c., may be found.

## CASE III.

*To find the radius of the curve by taking dimensions on the ground, the map being known to be inaccurate, and the starting-point B being given.*

Range the tangents AB, DC till they meet at T; measure BT; then measure on TD till TC = BT; also measure BC. Then  $BO = \frac{1}{2} BC \cdot BT \div \sqrt{BT^2 - \frac{1}{4} BC^2}$  = radius required.

Ex. Let BT = 82.50 chains, and BC = 132.00 chains. Then  $BO = \frac{1}{2}(132 \times 82.5) \div \sqrt{(82.5)^2 - \frac{1}{4}(132)^2} = 5445 \div 49.5 = 110$  chains, the radius required.

*Or by Trigonometry.*

Range the tangents AB, DC till they meet at T, as before, then measure BT, and take the angle BTC,  $\frac{1}{2}$  of which is the  $\angle BTO$ ; then in the triangle BTO, right-angled at B, are given BT and the  $\angle BTO$  to find BO; whence by trigonometry,

$\cot. \angle BTO : \text{rad.} :: TC : BO$ , the radius required.

Ex. Let BT = 82.50 chains, and the angle BTC =  $106^\circ 16'$ .

Then $\cot. \frac{1}{2} \angle BTC = \cot. \angle BTO, 53^\circ 8'$	. . . . .	9.87501
: rad. or $\sin. 90^\circ$	. . . . .	10.00000
:: BT = 82.50 chains	. . . . .	1.91645
: BO = 110 chains, the required radius	. . . . .	2.04144

\* *Demonstration.*—In the  $\Delta BTH$ ,  $TH = \sqrt{BT^2 - BH^2} = \sqrt{BT^2 - \frac{1}{4} BC^2}$ , and by the similar  $\Delta s BHT, BHO$ ,  $\frac{BT^2 - \frac{1}{4} BC^2}{\sqrt{BT^2 - \frac{1}{4} BC^2}} (= TH) : BT :: \frac{1}{2} BC (= BH) : BO = \frac{1}{2} BC : BT \div \sqrt{BT^2 - \frac{1}{4} BC^2}$ . Q. E. D.

## CASE IV.

To find the radius of the curve, when the plan is known to be inaccurate, and the tangents AB, DC cannot be prolonged to meet at T on account of obstructions, the starting-point B of the curve being given.

From B measure a line BD, on the most convenient ground, to meet CD at D, taking the angles TBD, TDB; the sum of which taken from  $180^\circ$  gives the  $\angle$  BTD, whence by trigonometry,

$$\sin. \angle BTD : BD :: \sin. \angle TDB : BT.$$

Now in the right-angled triangle BTO are given BT and the angle  $BTO = \frac{1}{2} \angle BTD$ , to find the radius BO, which may be done as in Case III.

## PROBLEM II.

To lay out on the ground a railway curve by the common method.

Let AB, CD be two straight or tangential portions of a railway, the points BC being required to be joined by a circular curve BC, to which AB, CD shall be tangents at the points B and C; and let BO be the radius of the curve, which is supposed to be determined by one or

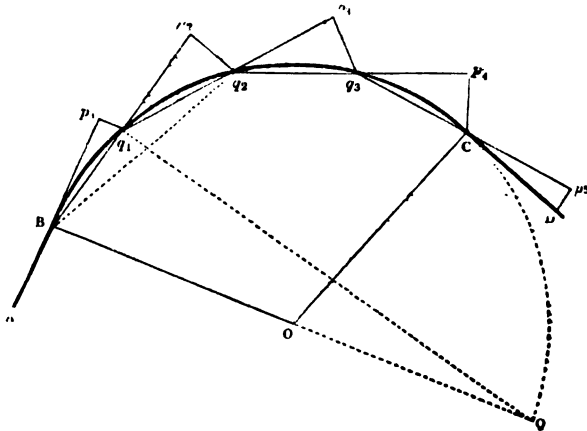

other of the cases in Problem I. accordingly as the map is found to be accurate or inaccurate. Put the radius  $BO = r$ ; measure on the tangent AB prolonged the distance  $BP_1 = 1$  chain, as is usual in

practice; set off  $p_1q_1 = \frac{1}{2r}$ \* at right angles to  $Bp_1$ ; then  $q_1$  is the first point in the curve. Through  $Bq_1$ , measure the right line  $Bq_1p_2 =$  twice  $Bp_1 = 2$  chains, and set off  $p_2q_2 = \frac{1}{r} =$  twice  $p_1q_1$  at right angles to  $Bq_1p_2$ ; then  $q_2$  is the second point in the curve, repeating the last operation till the curve reach the point C. Lastly,  $q_3Cp_3$ , being measured = 2 chains the last offset  $p_3D$  will be found = the first offset  $p_1q_1$ , or half the preceding one  $p_2q_2$ , if the work be right. See the following notes and example.

NOTE 1. Only a small part of the operation for a curve of great length is shown in the figure; but as the whole of the work, except the first and last offsets, is alike, to show more would be unnecessary.

2. The values of  $\frac{1}{2r}$  for all radii, from 15 chains to 540, are given in Table No. 4, at the end of the work.

Ex. Let  $BO = r = 80$  chains = 1 mile; then  $\frac{1}{2r} = \frac{1}{160}$  of a chain, which being multiplied by 792, the number of inches in 1 chain, gives  $\frac{1 \times 792}{160} = 4.95$  inches, the first offset  $p_1q_1$ ; whence  $4.95 \times 2 = 9.9$  inches, the second offset  $p_2q_2$ .

Or by Table No. 4, opposite 80, in the column marked Radius, &c., stands 4.95 inches, in the column marked Offsets, &c., which is the value of  $p_1q_1$ , as above.

3. By this method the greater part of British, as well as foreign, railway curves have been laid out, having been invented by Mr T. Baken, C.E., at a very early period, when the Stockton and Darlington railway was laid out. It was eagerly adopted by railway surveyors, as it involves very little calculation, and does not require the use of an angular instrument. It is, however, defective in practice, on account of its requiring the coupling together of so very many short lines, as small errors will unavoidably creep in and multiply (and more especially so if the ground be rough), so that the curve has frequently to be retraced several times

\* *Demonstration.*—Complete the semicircle  $BQ$ , prolong  $BO$  to  $Q$ , and join  $q_1Q$ ,  $Bq_2$ . Then because  $Bp_1$ ,  $Bp_2$ ,  $Bq_2$ , are always, in practice, so very small compared with  $BQ$  that they nearly coincide with the curve, and consequently  $Bp_1$  is approximately  $= Bq_1 = q_1p_2 = q_1q_2 = \frac{1}{2}Bq_2$ ;  $\therefore$  by the nature of the circle the  $\Delta s$   $Bq_1Q$ ,  $Bp_1q_1$ ,  $Bp_2q_2$ , are similar, and

$$BQ : Bq_1 :: Bq_1 : p_1q_1 = \frac{Bq_1^2}{BQ} = \frac{Bp_1^2}{BQ} = \frac{\delta^2}{2r}.$$

$$\text{also} \quad : \quad : Bq_2 : p_2q_2 = Bq_1 \times Bq_2 = \frac{2Bp_1^2}{BQ} = \frac{\delta^2}{r}.$$

$BO = \frac{1}{2}BQ$  being put  $= r$ , and  $Bp_1 = Bq_1 = \&c. = \delta$ ; and when  $\delta = 1$  chain, as in practice,  $p_1q_1 = \frac{1}{2r}$ , and  $p_2q_2 = p_3q_3 = \&c. = \frac{1}{r}$ . Q. E. D.

before it can be got right, especially if it be a long one. *This defect in the above method induced the author to prepare three other and more accurate methods, which are given in the following Problems.*

4. When the curve shall have been laid out with sufficient accuracy, the rods or quills that mark the ends of the offsets,  $q_1, q_2$ , &c., must be taken out and their places supplied by strong wooden stumps, about 16 or 18 inches in length, and  $1\frac{1}{2}$  inch square, each end of the curve being marked with three stumps, or one large one with a cross or some other conspicuous mark on it. The straight portions of the line must also be marked with stumps at the end of every chain.

PROBLEM III.

*To lay out a railway curve by ordinates or offsets from its tangents, no material obstructions being supposed to exist on the convex side of the curve, to prevent the use of the chain.*

CASE I.

*When the length of the curve is less than  $\frac{1}{4}$  of its radius.*

Let BC be the curve, AB, CD, tangents thereto, which are ranged till they meet at D, and BO the radius of the curve, which must be correctly determined by one or other of the cases in Prob. I.

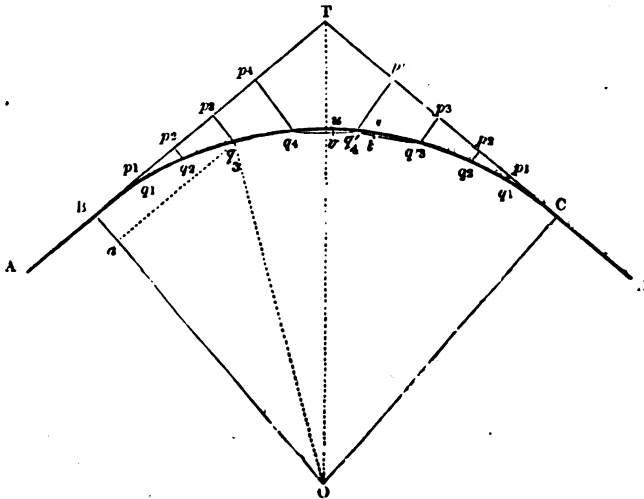

according to circumstances. Measure on BT the usual distance  $Bp_1 = 1$  chain, and lay off the offset  $p_1q_1 = \frac{1}{2r}$  ( $r$  being the radius of the curve as before), then measure  $p_1p_2 = 1$  chain, and lay off

$p_1q_1 = \frac{2^2}{2r}$ . The successive offsets at the end of every chain being  $\frac{1}{2r} \frac{2^2}{2r} \frac{3^2}{2r} \frac{4^2}{2r}$  &c.,\* or, what amounts to the same thing, the 2d, 3d, 4th, &c., offsets are respectively  $2^2, 3^2, 4^2, \&c.$ , times the first offset, or 4, 9, 16, &c., times the first one.

Having laid out the offsets in this manner, till the last one, which suppose to be  $p_4q_4$ , is either within, or very little more than, a chain from T, make  $p_4T = p_4q_4$ , and lay out the very same offsets in an inverted order, on TC, as were laid out on BT, that is, beginning with the greatest first and ending with the least.

Ex. Let the radius of the curve be 80 chains, then  $p_1q_1 = \frac{1 \times 792}{2 \times 80} = 4.95$  inches; whence  $p_2q_2 = 4 \times 4.95 = 19.8$  inches,  $p_3q_3 = 9 \times 4.95 = 44.55$  inches = 3 ft. 8.55 in., &c., or the value of the first offset may be taken from the table at the end of the book.

*To make the distances of the stumps equal.*

As it can rarely happen in practice that the distance  $q_1q'_1$  will be = 1 chain, when this is the case it will be better to set out the curve from C as was done from B; then, if the distance  $q_2q'_2$  be less than 1 chain, suppose  $m$  links less, lay the chain from  $q'_1$  to  $q'_2$ , and at the distance  $q'_1t = m$ , lay off the offsets  $ts = \frac{m(1-m)}{2r}$ , then  $s$  will be the point for the stump, instead of  $q'_2$ , thus making  $q'_1s = 1$  chain. This operation must be repeated between  $q_2$  and  $q_3$ ,  $q_3$  and  $q_4$ , &c., the last point to be changed necessarily falling on the tangent CD. If the distance  $q_4q'_4$  be greater than 1 chain by  $m$  links, lay the chain

\* *Demonstration.*—Draw the radius  $q_3o$ , and  $q_3a \perp$  to OB. Put  $OB = oq_3 = r$ , and  $q_3a = p_3q_3 = \delta$ ; then  $oa = \sqrt{r^2 - \delta^2}$ , and  $ba = p_3q_3 = OB - oa = r - \sqrt{r^2 - \delta^2}$ . Now, if  $\delta$  be taken successively =  $1^2, 2^2, 3^2, \&c.$ , chains, the values of  $p_1q_1, p_2q_2, p_3q_3, \&c.$ , will be respectively  $r - \sqrt{r^2 - 1^2}, r - \sqrt{r^2 - 2^2}, r - \sqrt{r^2 - 3^2}, \&c.$  But as  $1^2, 2^2, 3^2, \&c.$ , are very small compared with  $r^2$ , within the limitation assigned to Case I. of this Problem, the values of  $\sqrt{r^2 - 1^2}, \sqrt{r^2 - 2^2}, \&c.$ , may be taken respectively  $r - \frac{1^2}{2r}, r - \frac{2^2}{2r}, \&c.$ , without material error, whence  $p_1q_1 = r - \left(r - \frac{1^2}{2r}\right) = \frac{1^2}{2r}, p_2q_2 = r - \left(r - \frac{2^2}{2r}\right) = \frac{2^2}{2r}, \&c.$  But when the length of the curve exceeds  $\frac{1}{4}$  of its radius, only 5 or 6 of the offsets ought to be taken in this manner, and the remainder, say, commencing with  $p_7q_7$ , ought to be taken =  $r - \sqrt{r^2 - 7^2}, \&c.$ ; although in a curve of 80 chains radius, the 10th offset by the contracted method exceeds the same offset by the correct method by only  $\frac{1}{4}$  of a link out of 62 $\frac{1}{2}$  links. This difference, however, becomes gradually greater as the distance on the tangent approaches the 20th chain.

from  $q'$ , in the direction of  $q$ , and at the distance of  $q'v = m$  links, lay off the offset  $vu = \frac{(1+m)m}{2r}$ , then  $u$  will be the place for the stump; next lay the chain from  $q$ , in the direction of  $u$ , and repeat the previous operation: this must be done to the end of the curve, the last mark to be changed falling, in this case, within the curve. The stumps may now be put down as pointed out in Note 4, Prob. II.

Ex. 1. When the distance  $qq'$ , is less than 1 chain by 40 links, the radius of the curve being 80 chains. Here  $ts = \frac{(1-m)m}{2r} = \frac{(1-.40) \times 40}{160}$  ch. =  $\frac{.60 \times 40 \times 792}{160} = 1.188$  in. =  $1\frac{1}{4}$  inch nearly.

Ex. 2. When the distance  $qq'$ , is more than 1 chain by 40 links, and rad. = 80 chains. Here  $vu = \frac{(1+m)m}{2r} = \frac{(1+.40) \times 40}{160}$  ch.  $\times \frac{(1.40 \times 40) \times 792}{160} = 2.742$  in. =  $2\frac{3}{4}$  inches nearly.

CASE II

*When the curve is any required length.*

As it is inconvenient in practice to have the offsets greatly to exceed two chains in length; if, therefore, the curve be a long one, the offsets may be confined within proper limits by dividing the curve

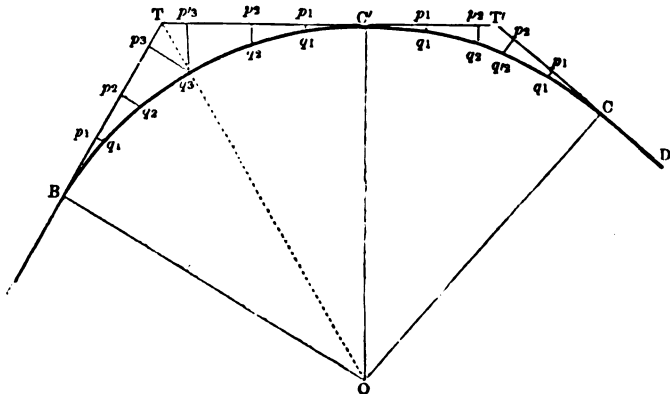

into two or more parts, and introducing one or more additional tangents. In the annexed figure the curve BC is divided into two parts in  $C'$ , at which point the tangent  $T'C'$  is drawn, meeting the tangents  $BT$ ,  $T'C$  in  $T$  and  $T'$ , the tangents  $BT$ ,  $T'C$  being each taken =

$Bp + \frac{1}{2}p_2q_2$ ,\* wherein  $Bp_2$  is taken the nearest whole number of chains to  $\frac{1}{2}BO$ , and  $p_2q_2$  is the offset corresponding to  $Bp_2$ . By thus taking the length of  $BT$ ,  $TC'$ , the last offset on  $BT$  and the first one on  $TC$  will meet at  $q_2$ , the middle point of  $BC'$ , and therefore the distances of the ends of the offsets that form the curve will all be sufficiently near to equality, *i.e.*, to one chain. Also by trigonometry,  $BT : BO :: \text{rad.} : \tan. \angle BTO = \frac{1}{2} \angle BTC'$ ; whence the  $\angle BTC'$  becomes known, and consequently the direction of the new tangent  $TC'T'$  is also known. Having, therefore, determined  $BT$  and  $\angle BTC'$ , the offsets may be laid out to  $p_2q_2$ ; and having made  $TP_2 = TP'_2$ , the same offsets may be laid out in an inverted order on  $TC'$ ; the order of the offsets being a second time inverted on  $C'T'$ , and a third time on  $T'C$ . If the distance of the middle offsets  $q_2q'_2$  be less or greater than 1 chain, that distance, and consequently the following ones, must be made equal to 1 chain, as in the preceding case.

EX. Let  $BO = 240$  ch., then  $Bp_2 = \frac{1}{2}BO = 30$  ch.,  $p_2q_2 = \frac{Bp_2^2}{2BO} = \frac{30^2}{480} = 1.875$  ch. : whence  $BT = TC' = Bp_2 + \frac{1}{2}p_2q_2 = 30 +$

$\frac{1}{2}1.875 = 30.2344$  ch. =  $30.23\frac{1}{2}$  ch. nearly : and by trig.

As 30.2344 (BT) log.	. . .	1.48050
: 240 (BO) . . . .	. . .	2.38021
:: rad. . . . .	. . .	10.00000
: tan. $\frac{1}{2} \angle BTC' = 82^\circ 49'$	. . .	10.89971
		2

$\angle BTC = 165^\circ 38'$ , whence the position of the tangent  $TC'T'$  becomes known; it will be unnecessary in this case to find  $\angle TT'C$ .

By table 4, the first offset on  $BT$ , *viz.*  $p_1q_1 = 1.65$  in., from which the other offsets may be found by multiplying by 4, 9, 16, &c., which may be laid out as in the last case,  $p_2q_2$  being the 30th offset from  $B$ , and meeting the corresponding offset  $p'_2q'_2$  at  $q_2$ , the middle of the curve  $BC'$ . The method of making the distances equal on the second part  $C'C$  of curve, if required, is the same as in Case I.

NOTE.—If the curve be a long one, it may be divided, in this manner, into 3, 4, or 5 parts, according to its length.

---

\* *Demonstration.*—By the similar triangles  $OBT$ ,  $q_2p_2T$ ,  $OB : Bp_2 + p_2T$  ( $BT$ ) ::  $p_2q_2 : p_2T$ ; but since  $Bp_2 = \frac{1}{n} OB$ , or the nearest whole number to it, and since  $p_2T$  must always be very small compared with  $Bp_2$ , it may be rejected;  $\therefore OB : \frac{1}{n}OB$  (=very nearly to  $BT$ ) ::  $p_2q_2 : p_2T = \frac{1}{n}p_2q_2$ , wherein  $n$  may be taken any whole number, 8 being the most convenient, as in the example.



## CASE III.

When the length of the curve exceeds the limit adopted in Case I., but is considered too short to be divided into two parts, as in Case II.

Let the curve be one of 80 chains radius, and between 32 and 38 chains in length, then to avoid the trouble of adding another tangent, the offsets beyond the 8th must be calculated from the following formulæ :—

$$\begin{aligned} p_1q_1 &= r - \sqrt{r^2 - 9^2} \\ p_2q_2 &= r - \sqrt{r^2 - 10^2} \\ &\&c. = \&c. \end{aligned}$$

If the radius of the curve be 160 chains, and its length about 50 or 60 chains, the offsets must be calculated, as above, beyond the 15th. The formula  $\frac{1^2}{2r}$ ,  $\frac{2^2}{2r}$ ,  $\frac{3^2}{2r}$ , &c., is a very near approximation

to the true lengths of the offsets within the limits assigned, but beyond these limits the errors of the offsets begin gradually to augment, till they become too considerable to be overlooked. See Demonstration to Case I.

## PROBLEM IV.

To lay out the curve, by two theodolites, where water, swamps, quarries, or other obstructions prevent the use of the chain.

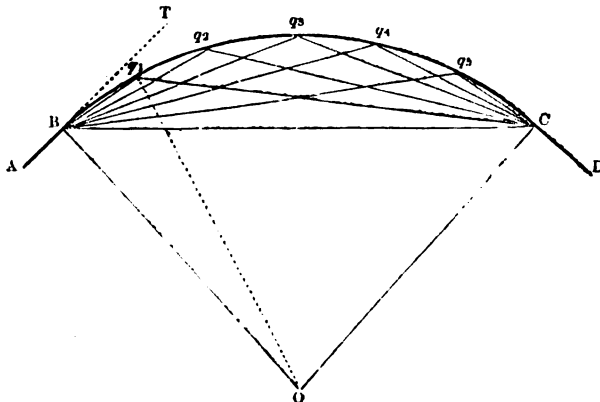

The position of the tangents AB, DC to the curve at its extremities B and C, its radius OB or OC, and the  $\angle$  BOC = supplement of the angle made by the tangents when prolonged, being determined; join

BC, and take several equidistant points  $q_1, q_2, q_3, \&c.$ , in the curve, from which points draw lines to B and C.

Take the  $\angle q_1CB =$  an arc whose sine is  $\frac{\delta}{2r}$ , wherein  $\delta = Bq_1 = q_1q_2 = \&c.$ , and  $r = OB$ , or, because  $\delta$  is, in practice, usually required to be = 1 chain, take  $\angle q_1CB =$  arc whose sine is  $\frac{1}{2r}$ .

The several angles may then be arranged as below:—

$$\begin{array}{ll} \angle q_1CB = \text{arc to sin. } \frac{1}{2r} & \text{and } \angle q_1BC = \frac{1}{2} \angle BOC - \angle q_1CB, \\ \angle q_2CB = 2 \angle q_1CB, & \angle q_2BC = \frac{1}{2} \angle BOC - 2 \angle q_1CB, \\ \angle q_3CB = 3 \angle q_1CB, & \angle q_3BC = \frac{1}{2} \angle BOC - 3 \angle q_1CB, \\ \angle q_4CB = 4 \angle q_1CB, & \angle q_4BC = \frac{1}{2} \angle BOC - 4 \angle q_1CB, \\ \&c. = \&c. & \&c. = \&c. \end{array}$$

Therefore if theodolites be fixed at B and C, and the angles  $q_1CB, q_2BC$  be taken at the same time, the intersection of  $Bq_1$  and  $Cq_1$  will give the point  $q_1$ . In the same manner by taking the angles  $q_2CB, q_3BC$ , the intersection of  $Bq_2$  and  $Cq_2$  will give the point  $q_2$ , &c.

Ex. Let the radius  $OB = 80$  chains, and the angle between the tangents  $AB, DC$ , when prolonged to meet, be  $160^\circ$ ; then its supplement =  $\angle BOC = 80^\circ$ , and  $\frac{1}{2} \angle BOC = 40^\circ$ . Also  $\angle q_1CB =$  arc to sine  $\frac{1}{2r} \left( = \frac{1}{160} = .00625 \right) = 0^\circ 21' 29''$ , whence  $\angle q_1BC = \frac{1}{2} \angle BOC - \angle q_1CB = 40^\circ - 0^\circ 21' 29'' = 39^\circ 38' 31''$ ;  $\angle q_2CB = 2 \angle q_1CB = 2 \times 0^\circ 21' 29'' = 0^\circ 42' 58''$  and  $\angle q_2BC = \frac{1}{2} \angle BOC - 2 \angle q_1CB = 40^\circ - 0^\circ 42' 58'' = 39^\circ 17' 2''$ , &c. The angles would be best arranged for use as follows, the opposite ones to be taken at the same time.

$$\begin{array}{llll} \angle q_1CB = \text{arc to sin. } .00625 = 0^\circ 21' 29'' & \angle q_1BC = \frac{1}{2} \angle BOC - \angle q_1CB = 39^\circ 38' 31''; \\ \angle q_2CB = 2 \angle q_1CB = 0^\circ 42' 58'' & \angle q_2BC = \frac{1}{2} \angle BOC - 2 \angle q_1CB = 39^\circ 17' 2''; \\ \angle q_3CB = 3 \angle q_1CB = 1^\circ 4' 27'' & \angle q_3BC = \frac{1}{2} \angle BOC - 3 \angle q_1CB = 38^\circ 55' 33''; \\ \angle q_4CB = 4 \angle q_1CB = 1^\circ 25' 56'' & \angle q_4BC = \frac{1}{2} \angle BOC - 4 \angle q_1CB = 38^\circ 34' 4''; \\ \&c. = \&c. & = \&c. & = \&c. & = \&c. \end{array}$$

This list of angles must be continued till  $n \angle q_1CB$  can no longer be taken from  $\frac{1}{2} \angle BOC$ , and one angle in each column being taken at the same time, as  $\angle q_1CB$  at C and  $\angle q_1BC$  at B, will give the point  $q_1$ : and so on for the other points  $q_2, q_3, \&c.$  See the following notes.

NOTE 1. Where the obstructions are such as to prevent the stumps being put down at the consecutive points  $q_1, q_2, q_3, \&c.$ , it would be best to take every fourth angle, thus obtaining the points  $q_4, q_8, q_{12}, \&c.$ , which will be 4 chains apart on the curve, the intermediate points being left to be put in when the work of the line has progressed so far as to present a better opportunity. Or, if it

should be thought preferable to avoid taking a multiplicity of angles, every fourth angle may be taken in any case, as this method is equally available whether obstructions exist or not.

*Demonst. to Prob. IV.*—The angles  $Bq_1C, Bq_2C, Bq_3C, \&c.$ , being in the same segment, are well known to be equal and constant, and also equal to half the supplement of  $\angle BOC$ , and consequently the sums of the angles of the triangles  $Bq_1C, Bq_2C, \&c.$ , adjacent to  $BC$  are equal to  $\frac{1}{2} \angle BOC$ , whence  $\angle q_1BC = \frac{1}{2} \angle BOC - \angle q_1CB$ ,  $\angle q_2BC = \frac{1}{2} \angle BOC - \angle q_2CB$  (because equal angles stand on equal arcs)  $\frac{1}{2} \angle BOC - 2 \angle q_1CB, \&c.$  Also join  $oq_1$  and put  $BO = r$ , and  $Bq_1 = \delta$ , then it is well known that  $\frac{1}{2} \angle BOq_1 = \angle q_1CB$ , and because the sides  $BO, q_1O$  of the triangle  $BOq_1$  are equal,  $\sin. \frac{1}{2} \angle BOq_1 = \sin. \angle q_1CB = \frac{\text{rad.} \times \delta}{qr}$ ; or, by taking  $\text{rad.} = 1$ , and  $\delta = 1$  chain, as required in practice,  $\sin. \angle q_1CB = \frac{1}{2r}$  or  $\angle q_1CB = \text{arc sine } \frac{1}{2r}$ . *Q. E. D.*

PROBLEM V.

*To lay out a railway curve by means of ordinates or offsets from its chord or chords, no material obstructions being supposed to exist on the concave side of the curve to prevent the use of the chain.*

Let  $BC'C$  be a portion, or the whole, of a curve of a railway;  $AT, T'T'$  and  $CD$  tangents to the curve at  $B, C'$ , and  $C$ ;  $O$  the centre,  $OB$  the radius,  $BC'$  and  $C'C$  chords of the curve; which chords must not exceed 40 chains, if the radius be 80 or 120 chains, but they may be 60

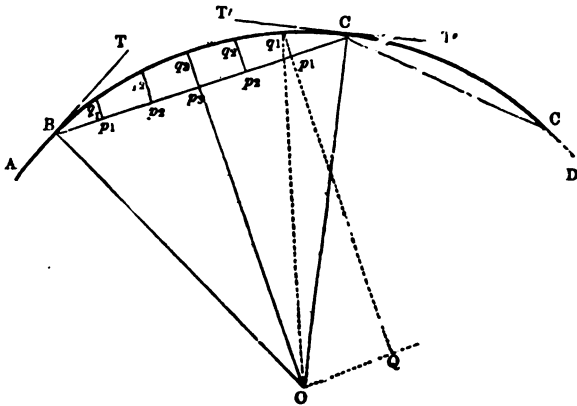

chains, if the radius exceed 120 (this limitation is necessary to prevent the offsets  $p_1q_1, p_2q_2, \&c.$ , being too long, as was observed with respect to the offsets from the tangents, in *Prob. III.*); and let the radius  $q_1O$  bisect the curve and chord in  $q_1$  and  $p_1$  respectively. Then from the right-angled triangle  $Bp_1O$ , in which  $BO$  and  $Ap_1 =$

$\frac{1}{2}BC'$  are given, the  $\angle BOp_3 = \angle TBC$  may be found, which determines the position of the chord  $BC'$ ; also  $Op_3$  may be found from the same triangle being  $= \sqrt{OB^2 - BP_3^2} = \sqrt{OB^2 - \frac{1}{4}BC'^2}$ . Put  $OB = r$ ,  $Op_3 = s$ , and the  $\frac{1}{2}$  chord  $Bp_3 = n$  chains, then

$$q_1p_1 = \sqrt{r^2 - (n-1)^2} - s,^*$$

$$q_2p_2 = \sqrt{r^2 - (n-2)^2} - s,$$

$$\&c. = \quad \&c.$$

$$q_3p_3 = \sqrt{r^2 - (n-3)^2} - s = r - s.$$

$q_3p_3$  being supposed to be the offsets at the middle point of the curve  $BC'$ , not the third offset as shown in the figure, it being impossible to draw all the offsets without confusing the figure, or making it unnecessarily large. After reaching the middle point  $q_3$  of the curve, the same offsets are repeated in an inverted order till the curve shall have been set out to  $C'$ . The same operation may be repeated as often as necessary, till the whole curve be completed, observing to make the  $\angle BC'C = 2$  complement of  $\angle TBC'$ , which has been already found. See the following notes:—

NOTE 1. When  $BC'$  is the whole curve, and its chord  $BP_3O$  includes a fractional part of a chain, the distance of the offsets on each side of the middle of the curve will be less than one chain; therefore that distance, and consequently the following ones, must be made equal, as was shown with respect to the distances in Problem III.

2. If the last chord, which suppose to be  $C'C$ , be less than the preceding chord or chords, the  $\angle Oc'C$ , must be found, and added to the  $\angle ObC'$  or  $OC'B$ , which will give the  $\angle Bc'C$ , showing the direction of the chord  $C'C$ .

3. This method of laying out the curve is seldom used, on account of the calculations it involves. It may, however, be used with advantage where a winding river or cliff is close to the convex side of the curve, or protrudes in some places a little through the curve; thus preventing the use of any other method, except that in Problem IV., which requires two theodolites.

*Definition of the compound curve.* (See figures to Prob. VI.)

The compound curve  $BCC'C''$ , joining the tangents  $AB$ ,  $DC''$ , is composed of three circular arcs  $BC$ ,  $CC'$ ,  $C'C''$ , having common normals,  $OC$ ,  $O'C'$  at their points of junction  $C$ ,  $C'$ ; and therefore common tangents at the same points, the radii of the three portions of the curve being respectively  $OB = OC$ ,  $O'C = O'C'$ , and  $O''C' = O''C''$ . This kind of curve is adopted where the line is required to pass through

\* *Demonstration.*—Draw  $OQ$  parallel to  $BC'$ ,  $q_1Q \perp$  to  $OQ$ , and join  $q_1O$ ; and let  $n$  = number of chains in  $\frac{1}{2}BC'$  or  $p_3C'$ , and  $C'p_1 = 1$  chain. Then  $p_1p_3 = OQ = n - 1$ ; and (Euc. I. 47)  $q_1Q = \sqrt{r^2 - (n-1)^2}$ ; whence  $q_1p_1 = \sqrt{r^2 - (n^2 - 1)^2} - p_1Q$ ; but  $p_1Q = p_3O = s$ ,  $\therefore q_1p_1 = \sqrt{r^2 - (n^2 - 1)^2} - s$ . Similarly,  $q_2p_2$  is found =  $\sqrt{r^2 - (n^2 - 2)^2} - s$ , &c. *Q. E. D.*

given points, as C and C', to avoid obstructions, or where a principal station or *terminus* is at or near C''; in the latter case the radius o''c'' may, if required, be less than 80 chains.

The compound curve may consist of two, three, or more portions of different arcs; thus the curve *bcc'* consists of two portions, *bc*, *cc'*.

### PROBLEM VI.

1. To find the several radii of the compound curve mechanically.

Let AB, DC'' be the tangential portions of the line, which are required to be joined by a curve passing through the points C, C', the point C'' not being given. Select a curve-ruler such that, being applied to touch AB at B, it may also pass through C; if this curve do not pass through C', but through some other point E, another curve ruler of less radius, in this case, must be selected, and such that it may touch the arc BC at C without cutting it or its prolongation towards E, and also pass through the point C: if this curve cut the prolongation C''T' of the tangent DC'', another curve-ruler of less radius than the last one must be selected, and such that it may touch curve CC' at C' and the tangent DC'' at C'': thus completing the curve BCC'C''. The radii OC, O'C, O'C'' may be determined from the curve-rulers, as in Case I. Prob. I.

2. To find the radius c'o' of the compound curve *bcc'* geometrically, the starting-point *b* and the radius *bo* being given.

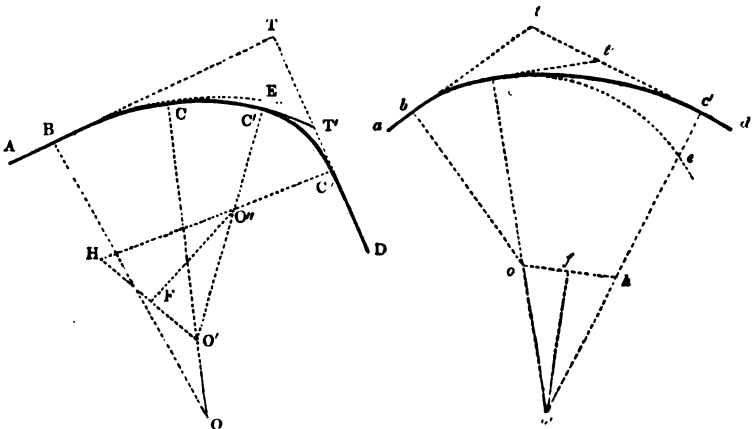

From the given point *b* in the tangent *ab* draw the given radius *bo*  $\perp$  to *ab*; and draw the curve to some point *c*, where it is found

convenient to change the radius : draw the radius  $oc$ , and thereunto draw  $ct'$ , meeting the tangent  $dt$  in  $t'$  ; make  $t'c' = t'c$ , and from  $c'$  draw  $c'o' \perp$  to  $tc'$  meeting  $co$ , prolonged if necessary in  $o'$  ; then  $o'$  is the centre of the arc  $cc'$  of the curve, conformable to the nature of tangents.

The method of constructing the curve, when it consists of three or more parts, is sufficiently obvious.

3. *One of the two radii of the compound curve and its starting and closing points being given, to find the other radius.*

Let  $ab, c'd$ , be the tangents,  $b$  and  $c'$  the starting and closing points of the curve. Draw the perpendiculars  $bo = c'h =$  given radius to the tangents ; join  $oh$ , and bisect it in  $f$  ; draw  $fo \perp$  to  $oh$ , meeting  $c'h$  prolonged in  $o'$  ; join  $o'o$ , and prolong it till  $oc = c'h$  : then the points  $o, o'$  are the centres of the arcs  $bc, c'o'$ , which constitute the compound curve,  $o'c = o'c'$  being the radius required.\*

NOTE.—In the compound curve  $bcc'o'$ , where the radius  $o'o'$ , which is to be found, is less than the preceding radius  $co$ , the  $\perp c'h$  is made  $= co$  ;  $ho'$  is joined and bisected in  $f$  ; and  $fo'$  drawn  $\perp$  to  $ho'$ , meeting  $c'h$  in  $o'$ , which is the centre of the arc  $c'o'$ , &c.

*Definition of the serpentine or S curve.* (See figure to Prob. VII.)

The serpentine curve  $BGC$  is used in railways, when obstructions or some other cause render its adoption preferable ; it consists of two circular arcs, having their convex sides turned in opposite directions, like the letter  $S$ , whence it is sometimes called the  $S$  curve ; the two portions  $BG, GC$  of the curve have a common normal  $OGO'$  at their point of junction  $G$ , and therefore a common tangent at the same point. This curve affords the most easy means of joining two parallel, or nearly parallel, portions of a line of railway.

### PROBLEM VII.

1. *When one radius and its tangential point are given, to find the other radius and tangential point of the serpentine curve geometrically.*

From the given tangential point  $C$  draw the given radius  $CO \perp$  to the tangent  $CD$ , and draw the curve  $CG$  to some point  $G$  where it is found convenient that it should have its point of contrary flexure ;

\* *Demonstration.*—Since  $of = fh$ , and  $fo'$  is  $\perp$  to  $oh$ ,  $oo' = o'h$  ; also  $bo$  was made  $= c'h = oc$  ;  $\therefore o'e = o'c'$  and the normal  $o'oc$  is common to the arcs of the curve. *Q. E. D.*

through OG draw the normal OGO'; from G draw GT ⊥ to OGO', to meet the tangent AT; make TB = TG; and draw BO' to AT, meeting

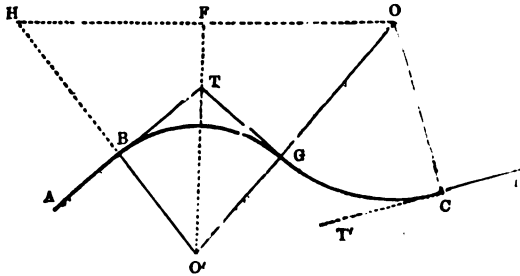

OGO' in O'; then O is the centre, and O'B = OG is the radius of the curve BG, as is evident from the nature of tangents.

NOTE.—The radius O'B and tangential point B may be found mechanically, *i.e.*, by the curve-rulers, as in Problems I. and VI.

2. *When the tangential points and one of the radii of the serpentine curve are given, to find the other radius geometrically.*

From the given tangential points C and B draw CO, BH, respectively ⊥ to the tangents CD and BA, and equal to the given radius; join OH, and bisect it in F; draw FO' ⊥ to OH, meeting HB prolonged in O', and join O, O'; making O'G = O'B; then O' is the centre, and O'B = O'G is the radius of the portion BG of the curve, as required.\*

NOTE 1. The radius BO' may be found mechanically as in the preceding case.

2. The radius o'b may be found from the following formula, wherein δ = BC, r = given radius OC, α = ∠TBC, and α' = ∠T'CB.

$$o'b = \frac{\delta(\delta - 2r \sin. \alpha')}{2\left(\delta \sin. \alpha + 2r \sin.^2 \frac{\alpha - \alpha'}{2}\right)}. \text{ See investigation and fig. to Problem VIII.}$$

Ex. Let δ = 200 chains, r = 110 chains, α = 45°, and α' = 20°; the sin. α = .70711, sin. α' = .34202,  $\frac{\alpha - \alpha'}{2} = \frac{45^\circ - 20^\circ}{2} = 12^\circ 30'$ , the sine of which is

$$\begin{aligned} \cdot 21644; \text{ and by the formula } o'b &= \frac{200(200 - 220 \times \cdot 34202)}{2(200 \times \cdot 70711 \times 220 \times \cdot 21644^2,} \\ \frac{200 \times 124 \cdot 7556}{2 \times 151 \cdot 7282} &= 82 \cdot 22 \text{ chains.} \end{aligned}$$

It may thus be readily ascertained whether the required radius o'b is greater, equal to, or less than 80 chains; if less, the given radius r ought either to be diminished, or the distance BC of the tangential points ought to be increased, according to circumstances, in order that o'b may be of the required length, assuming that the portion BG of the curve is not near a terminus or principal station.

\* The demonstration in this case is similar to the one given to Problem VI.

PROBLEM VIII.

1. *When the two portions of the serpentine curve have the same radius, to determine that radius geometrically, the tangential points and their distance being given.*

Let AB, DC be the tangents, B and C the tangential points, and BC the given distance. Draw  $Bo = Co'$  respectively  $\perp$  to AB, DC, and of any convenient length; through o, parallel to BC, draw oq

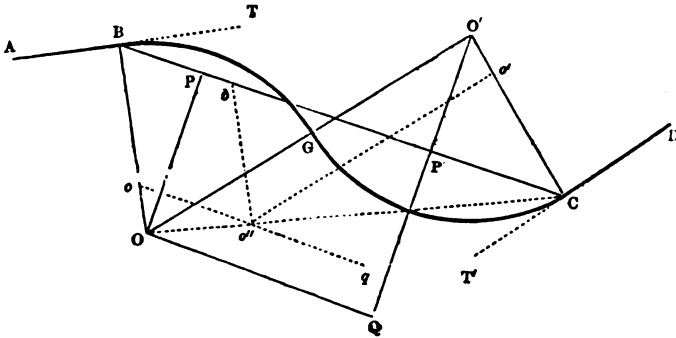

indefinitely; with the compasses apply  $o'o'' = 2Co' = 2Bo$ ; through C,  $o''$  draw  $co'o$ , meeting BO prolonged in o; and through o, parallel to  $o'o'$ , draw oo, meeting  $Co'$  prolonged in  $o'$ ; then o and  $o'$  are the centres, and OB and  $o'C$  are the equal radii of the serpentine curve BGC, the common normal of the portions BG, GC of the curve being  $OO' = 2Bo = 2Co'$ .\*

2. *To find the common radius of the two portions of the serpentine curve by calculation, the same things being given as in the preceding case, and the angles TBC,  $T'CB$ .*

Put  $BC = \delta$ ,  $Bo = Co' = r$ ,  $\angle TBC = \alpha$ , and  $\angle T'CB = \alpha'$ ; then

$$r = \frac{\delta}{\sin. \alpha + \sin. \alpha' + 2 \sin. \text{of arc to } \cos. \frac{1}{2} (\cos. \alpha + \cos. \alpha')} \dagger$$

\* *Demonstration.*—Draw  $o'b$  parallel to OB; then by similar triangles,  
 $co' : o'a'' = 2co' : : co' : 2co' = oo'$ ,  
 $co'' : co : : co' = Bo = bo'' : co'$   
 $\therefore co' : co : : co' = Bo = bo'' : Bo = co'$ . Q. E. D.

† *Investigation.*—Draw  $PO$ ,  $P'O' \perp$  to BC; through o draw oq parallel to BC, meeting  $o'P'$  prolonged in q: then  $OO' = 2r$ ,  $BP = r \sin. \alpha$ ,  $OP = P'Q = r \cos. \alpha$ ,  $CP' = r \sin. \alpha'$ ,  $o'P' = r \cos. \alpha'$ ,  $o'Q = o'P' + P'Q = r (\cos. \alpha + \cos. \alpha')$ : whence, from the right-angled triangle  $oo'Q$ ,  $\sin. \angle o'o'Q \frac{1}{2} (\cos. \alpha + \cos. \alpha')$ , which is therefore



Ex. Let  $\delta = 200$  chains,  $\alpha = 27^\circ$ ,  $\alpha' = 50^\circ$ : then from a table of nat. sines  $\sin. \alpha = \cdot 45399$ , its  $\cos. = \cdot 89101$ ;  $\sin. \alpha' = \cdot 76604$ , its  $\cos. = \cdot 64279$ : whence  $\frac{1}{2} (\cos. \alpha + \cos. \alpha') = \frac{1}{2} (\cdot 89101 + \cdot 64279) = \cdot 76690 = \cos.$  and 2  $\sin.$  of arc to  $\cos. \cdot 76690$  is  $1 \cdot 28334$ ; therefore

$$r = \frac{200}{\cdot 45399 + \cdot 76604 + 1 \cdot 28334} = \frac{200}{2 \cdot 50337} = 79 \cdot 89 \text{ chains, or nearly } 80 \text{ chains, the radius required.}$$

NOTE.—The method of forming the serpentine curve with a common radius is much to be preferred to any other, when the nature of the ground will admit of its being done; and more especially so, when the *data*, as in the preceding example, will only just give a common radius of 80 chains: for, if the radius of one of the portions of the curve had been taken greater than 80 chains, the other radius would have necessarily been less than 80 chains.

The Continental engineers, in laying out serpentine curves, usually place, if possible, a short *straight* piece of line between the two members of the curve, to ease the transfer of the train from one direction of curvature to the other.

### PROBLEM IX.

To make a given deviation HQ from a straight portion of a line of railway AHD by means of three curves, BG, GQG', G'C, having their radii OB, O'Q, O'C, all equal, in order that the lateral works of the line may avoid the building, or other obstruction b, which is close to the centre of the straight portion of the line.

1. *Construction.*—From the given point H draw HQ = given deviation  $\perp$  to AD; on QH prolonged, take QO' = OP = given radius; with the compasses apply PB = QP = twice given radius; draw

given, whence the comp. of  $\angle O'QO = \angle OO'Q$  is known, and may be thus expressed,  $\sin. \angle OO'Q = \sin.$  of arc to  $\cos. \frac{1}{2} (\cos. \alpha + \cos. \alpha')$ . Whence  $OQ = PF' = OO' \times \sin. \angle OO'Q = 2r \times \sin.$  of arc to  $\cos. \frac{1}{2} (\cos. \alpha + \cos. \alpha')$ ,  $\delta = BO = BP + PF' + F'O = r \sin. \alpha + r \sin. \alpha' + 2r \sin.$  of arc to  $\cos. \frac{1}{2} (\cos. \alpha + \cos. \alpha')$ , from which

$$r = \frac{\delta}{\sin. \alpha + \sin. \alpha' + 2 \sin. \text{ of arc to } \cos. \frac{1}{2} (\cos. \alpha + \cos. \alpha')} \quad Q. E. I.$$

When the radii are unequal, and one of them, as  $r = O'C$  is given, and the other  $R = BO$  is required; then  $O'O = R + r$ ,  $BP = R \sin. \alpha$ ,  $PO = F'Q = R \cos. \alpha$ ,  $O'Q = R \cos. \alpha + r \cos. \alpha'$ , and  $OQ = PF' = \sqrt{O'O^2 - O'Q^2} = \sqrt{(R+r)^2 - (R \cos. \alpha + r \cos. \alpha')^2}$ ,  $\delta = R \sin. \alpha + r \cos. \alpha' + \sqrt{(R+r)^2 - (R \cos. \alpha + r \cos. \alpha')^2}$ . By transposing and squaring, and remembering that  $\sin.^2 + \cos.^2 = 1$ , &c., there results  $\delta^2 - 2\delta (R \sin. \alpha + r \sin. \alpha') = 2Rr (1 - \cos. \alpha \cos. \alpha' - \sin. \alpha \sin. \alpha') = 2Rr (1 - \cos. \alpha - \alpha') = 4Rr \sin.^2 \frac{\alpha - \alpha'}{2}$ , whence

$$R = \frac{\delta (\delta - 2r \sin. \alpha')}{2 \left( \delta + 2r \sin.^2 \frac{\alpha - \alpha'}{2} \right)}. \quad \text{This formula is used for finding the value of } BO',$$

NOTE 2, Problem VII., where the symbols are defined. Q. E. I.

BO  $\perp$  to AD ; through O' draw O'GO parallel to PB, meeting OB in O ; make CH = HB ; and join CQ, QB, the latter cutting OO' in G, and the former cutting O'O'' (which is similarly drawn to OO') in G' : then B and C are the starting and closing points of the curve, of which the separate portions are BG, GQG', G'C, and the chords BG, GQ, QG', G'C are all equal.\*

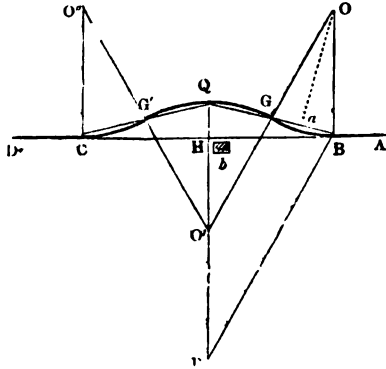

2. *Calculation.* — Take  $BH = HC = \sqrt{QH(4BO - QH)}$ , and  $BG = GQ = QG' = G'C = \sqrt{BO \cdot QH}$ , which chords of the arcs BG, GQ, &c., thus become known ; and, since the common radius BO is given, the construction of the curve is obvious.†

Ex. Let the given deviation  $QH = 2$  chains, and the common radius  $BO = 85$  chains ; then  $BH = HC = \sqrt{2(340 - 2)} = \sqrt{676} = 26$  chains, and  $BG = GQ = \&c. = \sqrt{2 \times 85} = \sqrt{170} = 13.04$  chains.

#### REMARKS ON LAYING OUT THE CURVES IN THE FOUR LAST PROBLEMS.

Having in the four last problems given various methods of determining the radii and common normals, indicating the positions of the tangent points of the parts of the compound, serpentine, and deviation curves, the method of laying out the curves themselves by Problems II., III., IV., or V., according to circumstances, will be readily seen, recollecting that when junction-points of curves of different radii occur, as CC', first fig. to Prob. VI., to commence the operation afresh, by using the radii and tangents of the respective portions of the curve.

\* *Demonstration.* — Because QR, BO are parallel, as are also O'o, PB ; O'P = BO = (by const.) QO' = given radius, and O'o = PB = 2QO' = 2QO' ;  $\therefore$  O'o = OQ = QO = BO, which are similarly proved to be = O'o' = O'o' = O'o'. Q. E. D.

† *Demonstration.* — Draw oa perpendicular to BQ, bisecting it in a ; then by similar triangles BO : Ba =  $\frac{1}{2}$ BQ : BQ : QH, whence  $BQ^2 = 4BO \cdot QH$ , or  $BQ^2 = \frac{1}{2}BQ^2 = BO \cdot QH$ , or  $BG = \sqrt{BO \cdot QH}$ . Also  $BH^2 = HC^2 = BQ^2 - QH^2 = 4BO \cdot QH - QH^2 = QH(4BO - QH)$ , or  $BH = HC = \sqrt{QH(4BO - QH)}$ . Q. E. D.

## SECTION IV.

## RAILWAY EARTH WORKS.

*On setting out the width of ground for a railway.*

After the centre stumps of the railway have been put down, which, as before observed, are usually at the distance of one chain apart, the line must next be carefully levelled, and the number of the stumps entered in the Level-Book, in a vertical column; and opposite each number, in a second column, the depth of the cuttings or embankments (see Level-Book, page 441); and in a third column, the computed or horizontal half-width of the surface cuttings as found by Problems I. and II. following; the depths of the cuttings and embankments being estimated from the balance line, which is 2 feet below the line of the rails or gradients, the 2 feet being filled up with gravel to form the way, and the beds for the sleepers of the rails.

The side stumps are next to be put down, which must be placed two on each side of every centre stump, in a direction perpendicular to the length of the line; or, if the line be curved, in a direction perpendicular to the tangent to the curve at the centre stump: the two interior stumps, *i.e.*, those next to the centre one, to mark the width of the cuttings, and the two exterior ones to mark the ditches of the side fences. The distances of every two of the interior stumps are to be entered in the Level-Book, opposite the number of the centre stump, in the main section, in order to ascertain the quantity of cuttings for the contractor; and the distances of every two of exterior stumps from the centre one are to be similarly entered, to ascertain the quantity of land which will be required from each proprietor for the works of the line; which last may be calculated accurately by the method of equidistant ordinates. (See Problem VI.)

## PROBLEM I.

*To set out the width when the surface of the ground is laterally on the same level as the intended railway.*

From the centre stump, perpendicular to the direction of the line, set out half the bottom-width for the cutting, to which add the width of the side-fence, putting down a stump at each distance; then repeat the operation on the other side of the line.

Ex. If the bottom-width of the railway be 30 feet, and the breadth of one of the side fences be 12 feet, required the widths for cutting and for fences.

$30 \div 2 = 15$  ft. = dist. of side-stump from centre for cutting.

$15 + 12 = 27$  ft. = dist. of side-stump from centre for fence.

Therefore,  $15 \times 2 = 30$  = whole width for cutting.

and  $27 \times 2 = 54$  = whole width for fences.

### PROBLEM II.

To set out the width of cuttings or embankments, when the surface of the ground is laterally level, and at a given height above the level of the intended railway, the ratio of the slopes being given.

Let ABCD be a cross-section of the cuttings, RS the horizontal surface of the ground, AB the bottom width, AC, BD

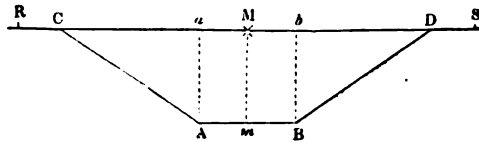

the slopes,  $Mm = Aa = Bb$  the perpendicular depth, and  $M$  the middle stump. Multiply the given depth  $Mm$  by the ratio of the slopes, to which add half the bottom-width  $Am$ , or  $aM$ : set out this distance from  $M$  to  $C$  for the half-width of the cuttings, to which add the width of the side fence for the whole half-width, repeating the same operation on the other side of  $M$ .

Ex. If the bottom-width  $AB$  or  $ab$  be 30 feet, the depth of the cuttings 28 feet, and the ratio of the slopes  $1\frac{1}{2} : 1$ , and the width of one of the side fences 12 feet, required the width of the cuttings, and of the land for the works of the railway.

$(28 \times 1\frac{1}{2}) + \frac{30}{2} = 42 + 15 = 57$  feet =  $MC = MD = \frac{1}{2}$  width of cuttings; and  $57 + 12 = 69$  feet =  $MR = MS = \frac{1}{2}$  width of land. The doubles of which are the whole widths.

If  $w$  = bottom-width =  $AB$ ,  $a$  = depth of cuttings =  $Mm$ ,  $f$  = width of one of the side-fences =  $RC$ , and the ratio of the slopes  $r : 1$ . Then

$1 : r :: a : aC = ar$ , hence  $ar + \frac{1}{2} w = MC = MD$ ,

$ar + \frac{1}{2} w + f = MR = MS$ ,

and  $2(ar + \frac{1}{2} w + f) = w + 2ar + 2f = RS$ .

*Construction.*—Draw  $AB$  = given width = 30 feet, perpendicular to which, at its middle point  $m$ , draw  $Mm$  = given depth = 28 feet; through  $M$  parallel to  $AB$  draw  $RMS$ ; through  $A$  and  $B$  draw  $Aa$ ,  $Bb$  parallel to  $Mm$ ; make  $aC = bD = 1\frac{1}{2}$  times  $Mm$ , join  $AC$ ,  $BD$ , and make

RC, DS = width of one of the side-fences = 12 feet. Then ABCD is a cross section of the cuttings, CD the surface-width thereof, and RS the whole surface required for the railway.

By inverting the last figure, so that ABCD may represent the cross-section of an embankment, it will be readily seen that the same method will apply, for setting out its half-widths, MC, MR, as that just given for the cuttings ; as the dimensions are the same in both cases.

NOTE 1. The ratio of the slopes is the proportion of the horizontal line ca to the depth aa or mm. Thus, when the ratio is 1 : 1, ca = aa : when the ratio is 2 : 1, ca = 2aa, &c. This ratio depends on the nature of the material through which the cuttings are made ; if it is close-jointed hard rock, the ratio is  $\frac{1}{2}$  or  $\frac{1}{3}$  to 1 ; if soft, or loose-jointed rock, or strong clay, the ratio is 1 or  $1\frac{1}{2}$  to 1 ; if springy ground, or loose sand, the ratio is 2 or  $2\frac{1}{2}$  to 1.

2. The computed half-widths, in the third column of the Level-Book (following Problem V.), are found by this Problem.

PROBLEM III.

To set out the width of the cuttings, when the surface of the ground is laterally sloping, the height of the centre stump above the level of the intended railway, the ratio of the slopes, and the lateral fall or rise of the ground in a given horizontal distance being given.

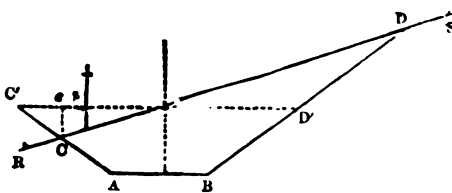

Let ABCD be a cross-section of the cuttings, RS the sloping surface of the ground, AB the bottom-width, Mm the depth of the cuttings, M the middle stump,

AC, BD the slopes, and C'D' a horizontal line passing through M, MC' = MD' being the computed half-widths.

Having set the level so that by turning the telescope two or three chains' length of the line may be seen, if possible, on both sides of it, place a levelling-staff at M, and another at q, and observe the level readings on them the difference of which will be pq ; measure with the tape-line in feet the distance Mq on the slope and the horizontal distance Mp ; take the computed half-width from the Level-Book, or find it by Problem II., and multiply it by the distance Mq on the slope, and reserve the product. Add and subtract the product of the difference of the staff-readings, and the ratio of the slopes, to and from the horizontal distance Mp, and reserve the sum and difference ; divide the reserved product by the reserved sum for the corrected

half-width MC, and by the reserved difference for the corrected half-width MD.

Ex. Let the depth of the cuttings at the centre-stump M be 20 feet, the bottom width AB = 30 feet, the distance Mg on the slope = 25 feet, the distance Mp on the level = 24 feet, the difference of the stave readings pq = 7 feet, and the ratio of the slopes  $1\frac{1}{2} : 1$ ; required the corrected half-widths MC, MD.

$$20 \times 1\frac{1}{2} + \frac{30}{2} = 45 \text{ feet} = \text{computed half-width}$$

$$\frac{25}{24} \times 45 = 46\frac{1}{2} \text{ reserved product.}$$

$$7 \times 1\frac{1}{2} = 10\frac{1}{2}$$

reserved sum  $46\frac{1}{2} - 10\frac{1}{2} = 36$  feet = cor.  $\frac{1}{2}$  width MC

reserved diff.  $46\frac{1}{2} + 10\frac{1}{2} = 57$  feet = cor.  $\frac{1}{2}$  width MD.

Put  $MC' = b$ ,  $pq = h$ ,  $Mq = s$ ,  $Mp = l$ ,  $MC = x$ ,  $MD = x'$ , and the ratio of the slopes  $r : 1$ .

$$\text{Then } x = \frac{bs}{l + rh} = MC^*$$

$$\text{and } x' = \frac{bs}{l - rh} = MD.$$

If the numbers in the preceding example be substituted in these formulæ, the work will stand thus :

$$MC = \frac{bs}{l + rh} = \frac{45 \times 25}{24 + (7 \times 1\frac{1}{2})} = \frac{1125}{34\frac{1}{2}} = \frac{2250}{69} = 32\cdot6 \text{ feet.}$$

$$MD = \frac{bs}{l - rh} = \frac{45 \times 25}{24 - (7 \times 1\frac{1}{2})} = \frac{1125}{13\frac{1}{2}} = \frac{2250}{27} = 83\cdot33 \text{ feet ;}$$

to each of which values of the corrected half-width, the width of

\* *Demonstration.*—Draw  $cc'$  to  $c'd'$ ; then by similar triangles,  $s : h :: x : \frac{hx}{s} = cc'$ , hence  $c'c = \frac{rhx}{s}$ , and  $mc = c'm - c'c = b - \frac{rhx}{s}$ ; again, by similar triangles  $l : h :: b - \frac{rhx}{s} : cc = h$ ,  $\frac{(bs - rhx)}{ls} = \frac{hx}{s}$ , whence  $x = \frac{bs}{l + rh} = MC$ ; and in a similar manner is found  $x' = \frac{bs}{l - rh} = MD$ . Q. E. D.

Cor. When the difference of the level readings is so large that the horizontal distance  $l$  cannot be conveniently measured, the value of  $l = \sqrt{s^2 - h^2}$  must be substituted, thus giving

$$MC = \frac{bs}{\sqrt{s^2 - h^2} + rh}, \text{ and } MD = \frac{bs}{\sqrt{s^2 - h^2} - rh}.$$

one of the side-fences must be added for the whole breadth of land required.

**NOTE 1.** When the difference of level-readings is small,  $l$  may be taken  $=s$  without material error.

2. A little practice will make this method of finding the corrected half-widths very easy. It is evidently much superior to the method of finding the same things by the blundering approximations often in use, especially where the difference of the levels of  $c$  and  $D$  is very considerable, and the surface of the ground has a regular slope, which often happens to be the case, or very nearly so; or, if the surface be a little uneven, a skilful engineer, by applying the tape-line in the general direction of the surface of the ground, will be readily able to correct the difference  $pq$  of the level-readings, so as to adapt it to his purpose. If, however, the surface of the ground be very uneven, which sometimes happens to be the case, it will be best to use the method of approximation, as in Problem V.

**Construction.**—Draw the cross-section  $ABD'C'$  as in the preceding Problem; make  $mp =$  given horizontal distance; draw  $pq$  perpendicular to  $C'D'$  and equal to the difference of the level readings; and through  $Mq$  draw  $RS$ , cutting  $AC'$  in  $C$  and  $BD'$  prolonged in  $D$ : then  $ABDC$  is the required cross-section of the cuttings,  $RC$ ,  $DS$  being the breadths of the side fences.

By reversing the cross-section, it will be seen that the preceding calculation and construction will also apply to an embankment; but in this case the lesser distance  $MC$  must be measured up the slope, and the greater  $MD$  down it.

#### PROBLEM IV.

*To set out the widths when the surface of the ground is laterally sloping, and when the cross-section of the works consists partly of a cutting and partly of an embankment, the things given being the same as in the preceding Problem.*

Let  $ACPBD$  be a cross-section of the works of a railway, consisting partly of the cutting  $BPD$ , and partly of the embankment  $APC$ ;  $AB$  the bottom-width;  $M$  the centre stump, and  $Mm$  the depth of the cutting;  $RS$  the sloping

surface of the ground, &c. When the embanked part,  $APC$ , is less than half the bottom-width  $Am$ , proceed to find, as in Problems II. and III., the computed half-width  $MD'$ , and from thence the corrected half-width  $MD$ . But to find the corrected half-width  $MC$  (which consists

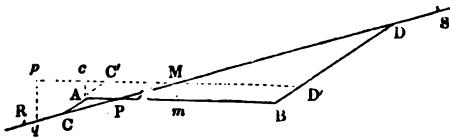

partly of an embankment), multiply the distance MD (just found) by the difference of the bottom-width and the estimated half-width, and divide the product by the estimated half-width, and the quotient is the corrected half-width MC.\*

Ex. Let the bottom-width  $AB = 30$  ft., the depth  $mm = 3$  ft., the ratio of the slopes  $1\frac{1}{2} : 1$ , and the difference of level-reading 7 ft., at the distances of 25 and 24 ft. from the centre-stump on the surface-slope, and on the level respectively; required the corrected half-widths MD and MC.

By Problem II.  $3 \times 1\frac{1}{2} + \frac{30}{2} = 19\frac{1}{2}$  ft. = estimated half-width MD',

By Problem III.  $\frac{19\frac{1}{2} \times 25}{24 - (7 \times 1\frac{1}{2})} = \frac{975}{27} = 36.11$  ft. = corrected half-width MD.

By Problem IV.  $\frac{36.11 \times (30 - 19\frac{1}{2})}{19\frac{1}{2}} = 19.44$  ft. = corrected half-width MC.

If the same symbols be used for the given parts in this example, as in Problem III., and  $w =$  bottom-width : then

$$MD = \frac{bs}{l - rh} = \frac{19\frac{1}{2} \times 25}{24 - (7 \times 1\frac{1}{2})} = 36.11 \text{ ft.} = \text{corrected half-width.}$$

$$MC = \frac{(w - b)s}{l - rh} = \frac{(30 - 19\frac{1}{2})25}{24 - (7 \times 1\frac{1}{2})} = 19.44 \text{ ft.} = \text{corrected half-width.}$$

NOTE.—This operation for finding MC, it will be seen, is different from the preceding one. See *Demonstration*.

*Construction.* The operation for this Problem is the same as that for Problem III., excepting that AC is drawn parallel to BD.

By reversing the cross-section, it will be readily seen that the same calculation and construction will apply in the case of APC being a cutting, and PBD an embankment, observing that the corrected half-width for the cutting is the shorter distance, and *vice versa*.

\* *Demonstration.* Draw  $ac \perp$  to  $o'b'$  prolonged, and let  $pg$ , which is  $\perp$  to  $po'v'$ , be the difference of level-readings at  $m$  and  $q$ ; then, if  $a = mm$ ,  $mc = am = \frac{1}{2}w = \frac{1}{2}$  bottom width, the other symbols being the same as in the *Demonstration* to Problem III.,  $ar = c'o'$  and  $o'm = mc - c'o' = \frac{1}{2}w - ar$ ; whence, by the *Demonstration* above referred to,  $mc = \frac{s(\frac{1}{2}w - ar)}{l - rh}$ ; but  $b = \frac{1}{2}w + ar$ , or  $ar = b - \frac{1}{2}w$ ; this value being substituted in that of  $mc$ , gives  $\frac{s(w - b)}{l - rh} = mc$ . Also  $\frac{s(w - b)}{l - rh} = mc = \frac{bs}{l - rh} \times \frac{w - b}{b}$ , which is the rule given in words at length. Q. E. D.



## PROBLEM V.

To find the width of the cuttings when the surface of the ground is laterally very uneven.

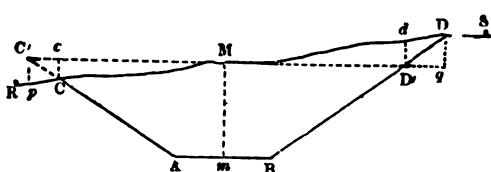

Let  $ABDMC$  be a cross-section of the cuttings,  $mm$  the depth,  $C'M = MD' =$  estimated half-width,  $CDM$  the uneven surface

of the ground, &c. The solution of this Problem will be best effected by giving an example in numbers.

Let  $AB = 30$  ft.,  $mm = 30$  ft., and the ratio of the side-slopes as  $1\frac{1}{2} : 1$ ; then  $MC' = MD' = (30 \times 1\frac{1}{2}) + (\frac{1}{2} \times 30) = 60$  ft. Measure from  $M$  horizontally the distance  $md = 60$  ft; the point  $d$  is directly above  $D'$ . Place levelling-staves at  $M$  and  $d$ , and observe the difference of the readings at  $M$  and  $d$ , which, in this base, is 7 ft.; whence  $7 \times 1\frac{1}{2} = 10\frac{1}{2}$  ft. = approximate distance  $dD$ , and  $md + dD = D = 60 + 10\frac{1}{2} = 70\frac{1}{2}$  ft. Now place a levelling-staff  $D$ , and observe the reading, which is found to be 7.8 ft. greater than that at  $M$ , or 0.8 ft. greater than that at  $d$ ; whence  $0.8 \times 1\frac{1}{2} = 1.2$  ft., and consequently  $70\frac{1}{2} + 1.2 = 71.7$  ft., which is a still nearer approximation to the true distance  $MD$  or  $Mg$ , it being measured horizontally. The operation for finding  $mc$ , or  $MC$  measured horizontally, is the same as the preceding, excepting that the product of the staff-readings is subtracted from the estimated half-width, &c. In this manner the distance  $Mc =$  horizontal distance  $MC$  is found to be 52.6 feet.

NOTE 1. The widths  $RC$ ,  $DS$ , of the side-fences, must be added to the above results for the whole width.

2. If the difference of the staff-readings at  $M$  and  $d$  be very large, it will require three or four approximations similar to those given in the preceding example to find the true corrected half-width.

*Construction.* Take the levels of the several undulations of the surface  $CMD$ , making  $C'MD'$  the datum-line, and draw the cross-section  $ABDMC$  by the methods already given.

By reversing the cross-section  $ABDMC$ , its application to an embankment is obvious, observing also to reverse the distances  $MC$ ,  $MD$ , as previously noticed.

3. The truth of the method of approximation used in this example is too obvious to require a demonstration.

## LEVEL-BOOK.

	No. of Stump.	Depth of Cuttings or Embankments.	Computed Half-width.	Corrected half-widths for edge of Cutting or foot of Embankment.		Whole widths including Fences, each Nine Feet in Width.
				North.	South.	
		Feet.	Feet.	Feet.	Feet.	Feet.
Embankt. Cutting.	216	30'00	60'00	52'60	71'70	142'30
	217	3'00	19'50	19'44	36'11	73'55
	218	28'00	57'00	57'95	56'08	133'55
	219	19'68	44'42	44'42	44'42	106'82
	220	20'00	45'00	32'60	83'33	133'93
	221	16'08	39'12	39'72	59'12	116'84
	222	30'00	60'00	54'24	68'05	140'29
	223	32'18	63'27	63'00	63'62	144'62

NOTE.—The depths of cuttings or embankments in the 2d column of the preceding Level-Book are found by calculation, or by carefully measuring them from the section by the vertical scale, but the latter method is not sufficiently correct. The computed half-widths in the 3d column are found by Problems I. and II. The corrected half-widths in columns 4th and 5th, by the five preceding Problems, according to the nature of the cuttings or embankments.

## PROBLEM VI.

*To find the quantity of land required for a projected railway.*

## CASE I.

*In preparing the preliminary estimates for a projected railway, the quantity of land required for the purpose is usually found without paying any regard to the lateral inclination of the ground, by taking a considerable length of the section at once, especially if the surface thereof have a regular rise or fall, and by measuring the depth of the ends of such length with the vertical scale.*

RULE.—Find the surface-widths, fences included, at each end of the given length, by Problems I. and II., add them together, multiply the sum by the length in chains, and divide the product by 1320 for the area in acres.

Ex. Let the length of the sectional surface be 18 chains, and the depths at the ends 22 and 38 feet, the bottom-width of the railway 33 feet, and the ratio of the slopes  $1\frac{1}{2}$  to 1; required the area of the surface, the width of the side-fences being 9 feet each.

$$\text{By Prob. II. } w + 2ar + 2f = 33 + (3 \times 22) + (2 \times 9) = 117$$

$$w + 2br + 2f = 33 + (3 \times 38) + (2 \times 9) = 165$$

$$\underline{282}$$

$$18$$

$$1320 \left\{ \begin{array}{l} 12 \overline{) 507 \cdot 6} \\ 11 \overline{) 42 \cdot 3} \end{array} \right.$$

A. R. P.

$$3 \cdot 84545 = 3 \ 3 \ 15$$

or by putting  $l$  = given length, and taking half the sum of the widths, there will result

$$\frac{(w + ra + b + 2f)l}{660} = (33 + 1\frac{1}{2} \times \overline{22 + 38} + 2 \times 9) \frac{18}{660} = 3 \cdot 84545 \text{ acres.}$$

## CASE II.

*When the exact quantity of land for the railway is required.*

**RULE.**—Take the whole widths at the end of every chain, from the 6th column of the Level-Book, for the several widths; add continually together the first and last widths, and twice the sum of all the intermediate widths, and divide the whole sum by 1320 for the area in acres.

**Ex.** Required the area corresponding to the several widths in the Level-Book at the end of Problem V.

$$73 \cdot 55$$

$$133 \cdot 03$$

$$106 \cdot 82$$

$$133 \cdot 93$$

$$116 \cdot 84$$

$$140 \cdot 29$$

$$\underline{704 \cdot 46}$$

$$2$$

$$1408 \cdot 92 = \text{twice sum of intermediate widths}$$

$$142 \cdot 30 = \text{first width}$$

$$144 \cdot 62 = \text{last width}$$

$$1320 \left\{ \begin{array}{l} 12 \overline{) 169 \cdot 584} \\ 11 \overline{) 14 \cdot 132} \end{array} \right.$$

$$1 \cdot 28473 = 1 \text{A. } 1 \text{R. } 5\frac{1}{2} \text{P.} = \text{area required.}$$

**NOTE.**—It is very common in practice to find the areas of the quantities of land required from the several proprietors, by actual measurement from the two chain maps, made for the use of the contractors, after the several widths have been laid down thereon: copies being taken, at the same time, from the maps, on tracing-paper, showing the position and quantity of land required from each proprietor.

## ON RAILWAY CUTTINGS IN GENERAL, AND TABLES FOR FINDING THEIR CONTENTS.

In preparing the preliminary estimates for a railway, the contents of the cuttings are usually found by tables for the purpose, the surface of the ground in the several cross-sections being assumed to be on a level with the centre of the line. But when power has been granted for constructing the line, the cross-sections are carefully taken at the end of every prominent variation of the surface of the ground, or, if consistent with accuracy, at the end of every one, two, or three chains in length; and the several cross-sections are then plotted on a large scale, which may be done by the methods given in the preceding Problems. Their areas may then be found by actual measurement; or they may be reduced, where the surface of the ground is uneven, to horizontal sections. The contents are found, either by taking the mean of every two succeeding sections, *which method is very erroneous where the areas of the sections differ greatly*, or by finding the contents from the tables, by using the mean depths of the several sections, *which method is correct; but the mean depth used in this method cannot be accurately found in many cases without considerable calculation*. Some use a mean of the mean depths as the bases for a mean area, *which method is also very inaccurate, especially where the areas of the extreme sections differ greatly*. The magnitude of the errors in both cases will be pointed out in the investigations at the end of these Problems.

*On Earthwork Tables.*

Tables for this purpose have been published by Sir John M'Neill, Mr Bidder, Mr Bashforth, Messrs Sibley and Rutherford, and others; all of which are well adapted for finding the contents of cuttings, assuming the surface of the ground to be laterally level with respect to the direction of the cutting. But none of these tables are accompanied with directions for finding the contents from sectional areas, *i.e.*, from the areas of working drawings, excepting Mr Bashforth's tables; *but his mathematical investigation of the rule for using them in finding the contents from working drawings, where the surface of the ground is laterally sloping or uneven, is founded on a false assumption, and therefore his results are erroneous, and especially so where the sectional areas differ considerably*. (See the investigations at the end of these Problems.)

## THE GENERAL EARTHWORK TABLE.

*(At the end of the book.)*

This Table, with the help of the Auxiliary Earthwork Tables, Nos. 1 and 2, on the same sheet, possesses the advantage of being general for all varieties of slopes and bottom widths in common use, as well as for decimal parts of feet in the depths. It may also, with a very trifling preliminary calculation, be made to extend to every variety of bottom width and ratio of slope that can occur, if even the slopes of the two sides differ in the same cutting; and with the help of a table of square roots it will apply, with all attainable mathematical accuracy, to cuttings where the surface of the ground is uneven. The investigation of the method of forming the Tables and using them, will be given at the end of these Problems. The contents in the general Table, and those in Table No. 2, are calculated to the nearest unit for one chain in length, and checked by differences; the side-slopes being assumed to be extended till they intersect. The auxiliary Table No. 1 gives the depths of the intersections of the side slopes below the balance-line, and the corresponding number of cubic yards to be deducted from the contents for each chain in length.

## PROBLEM VII.

## CASE I.

To find the contents of cuttings by the General Earthwork Table, and the Auxiliary Table No. 1, at the end of the book.

Let  $ABbd\alpha C$  be a cutting,  $AB = ab$  = bottom width on the formation level,  $MM'$  and  $mm'$  the perpendicular depths at the middle of the two ends of the cutting;  $AC, BD, ac, bd$ , the side-slopes, which, being prolonged two and two will meet at the points  $N$  and  $n$ ; also  $MM'$  and  $mm'$ , being prolonged, will meet at the same points. The distance  $M'N = n'n$  in feet and decimals is given in the Auxiliary Earthwork Table

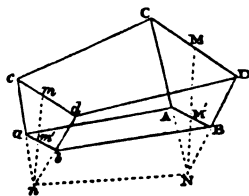

No. 1, for all bottom widths and ratios of slopes in common use, at which distance a line must be ruled on the section, parallel to the balance-line, or at the same distance + 2 feet from the line of the rails, in which latter case the balance-line need not be drawn. From the line thus ruled, the depths of the cutting must be measured to adapt them to the General Earthwork Table; or a mark might be made on the vertical scale with Indian ink (which is easily washed off) at the same distance, which mark might then be applied to the line of the

rails in measuring off the depths. For measuring the depths of embankments, the line must be ruled at the same distance—2 feet above the line of the rails. When the several quantities of a cutting or embankment have been taken from the Table, and their sum multiplied by the ratio of the slopes, the cubic yards to be deducted for each chain in length, for the particular bottom width and ratio of slopes, must be taken from Table No. 1 and multiplied by the whole length of the cutting, and the product, being subtracted from the result obtained from the General Table, will give the content of the cutting in cubic yards.

The method of using the Tables will best appear from the following examples.

**Ex 1.** Let the several depths of a railway cutting to the intersection of the slopes, at the end of every chain, be as in the annexed table, the bottom width 30 feet, and the ratio of the slopes  $1\frac{1}{2}$  to 1; required the content of the cutting in cubic yards.

**NOTE.**—By the Table No. 1 the depth to be added to the depths of the cutting, for bottom width 30 ft. and ratio of slopes  $1\frac{1}{2}$  to 1, is 10 ft., therefore the line from which the depths in the annexed table are measured is  $10 + 2 = 12$  ft. below the line of the rails. The corresponding number of cubic yards to be subtracted is carried to two places of decimals, or, if the nearest whole number had been taken, the quantity would have been in excess or defect by several cubic yards, when the cutting is of a considerable length.

Dist. in Chains.	Depths	Qts. per Table.
0	10	
1'00	29	1003
2'00	32	2276
3'00	33	2582
4'00	39	3175
5'00	35	3350
6'00	10	1365

For slope 1 to 1 . . .	13751
" $\frac{1}{2}$ to 1 . . .	6875'5
" $1\frac{1}{2}$ to 1 . . .	20626'5
Subtract	
366'67 × 6	} = 2200
Content in cubic yds.	} = 18426'5

**Ex 2.** Let the several depths to the intersection of the slopes and their distances be as in the annexed table, the bottom width 30 feet, and the ratio of the slopes  $1\frac{1}{2}$  to 1; required the content of the cutting.

**NOTE.**—When any of the distances is greater or less than 1 chain, the corresponding quantity must be multiplied by that distance; as in the cases of the distances between the depths 45 and 50, and between 30 and 10, the former distance being 3 chains and the latter 60 links.

Dist in Chains.	Depths	Dist greater than 1 Chain.	Qts. per Table.
0	10		
1'00	20		570
2'00	16		795
3'00	25		1044
4'00	32		1996
5'00	39		3091
6'00	45		4319
9'00	50	3 × 5520	16560
10'00	40		4971
11'00	30		3015
11'60	10	60 × 1059	635'4

For slopes 1 to 1 . . . . .	36996'4
" $\frac{1}{2}$ to 1 . . . . .	18498'2
" $1\frac{1}{2}$ to 1 . . . . .	55494'6
366'67 × 11'60 . . . . .	= 4253'4
Content in cubic yards . . . . .	51241'2

Ex. 3. The depth of a cutting to the intersection of the slopes and their distances in feet are as in the annexed table; the bottom width is 36 feet, and the ratio of the slopes 2 to 1; required the content of the cutting in cubic yards.

Dist. in Feet.	Depths	Qts. x by Length.	Products.
0	39		
100	61	6210 × 100	621000
188	50	7554 × 88	664752
178	37	4660 × 90	419400
For slopes 1 to 1 . . . .			1705152
			2
" 2 to 1 . . . .			3410304
			396 × 278 = 110088
			66) 3300216
Content in cubic yards . .			50003

NOTE.—When the distances are given in feet, the quantities from the General Table must be multiplied by their respective distances; also the quantity from Table No. 1 must be multiplied by the whole distance, and the final result divided by 66, as in the annexed example. See Demonstration at the end of these Problems.

## CASE II.

*To find the contents of cuttings by the Tables, when the depths are given in feet and decimals of feet.*

RULE.—Let any two succeeding depths be denoted by  $a$  and  $b$ , and let the decimal parts of the depths be respectively denoted by  $a'$  and  $b'$ ; find the quantity corresponding to  $a$  and  $b$  from the General Table, as in the former case; then

$\frac{2a + b}{10}$ , or its nearest whole number, and the decimal  $a'$  will show the number of cubic yards to be added in Table No. 2, and

$\frac{2b + a}{10}$ , or its nearest whole number, and the decimal  $b'$  will show the cubic yards to be added in the same Table.

Ex. 1. Let the depths to the intersection of the slopes be 61·6 and 39·4 feet, their distance 1 chain, the bottom width 36 feet, and the ratio of slopes 2 to 1; required the content of the cutting in cubic yards.

Put 61 =  $a$ , its decimal ·6 =  $a'$   
 39 =  $b$ , its decimal ·4 =  $b'$ .

Then the depths $a$ and $b$ , per General Table, give .	6210
$\frac{2a + b}{10} = 16.1$ , or its nearest whole No. 16 and ( $a'$ ) $\cdot 6$ per } Table No. 2 . . . . .	78
$\frac{2b + a}{10} = 13.9$ , or its nearest whole No. 14 and ( $b$ ) $\cdot 4$ per } Table No. 2 . . . . .	46
For slopes 1 to 1 . . . . .	6334
	2
For slopes 2 to 1 . . . . .	12668
By Table No. 1, for bottom width 36 feet and ratio of } slopes 2 to 1, No. of cubic yds. to be deducted . }	396
Content in cubic yards	12272

NOTE 1. Care must be taken to use the decimal  $a'$  with  $\frac{2a + b}{10}$ , and the decimal  $b'$  with  $\frac{2b + a}{10}$ , in finding the quantities in Table No. 2, as a mistake might easily be made in this matter, which would lead to an erroneous result.

2. If any two succeeding depths be nearly equal, and the sum of their decimal parts be together equal to 1 foot, or nearly so, by adding 1 foot to the lesser depth, and rejecting the decimal in the larger depth, and using the depths thus altered as whole numbers, a result sufficiently correct will be obtained; as in the following example.

Ex. 2. Let the depths of a cutting be 50.29 and 48.7 feet, their distance 1 chain, the bottom width 33 feet, and the ratio of the slopes  $1\frac{1}{2}$  to 1; required the content.

By adding the decimal $\cdot 29$ , in the larger depth, to 48.7, the depths may be called 50 and 49, for which, by the General Table, the content is . . . . .	5990 for 1 to 1
	2995 for $\frac{1}{2}$ to 1
	8985 for $1\frac{1}{2}$ to 1
from which deduct, from Table No. 1	443.67
	8541.33 cubic yards.

NOTE 1. The results of all the examples in the two preceding cases only differ by a very small fraction of a cubic yard from the true contents obtained by calculation from formula (1), page 456. The method of finding the contents to decimals or tenths of a foot in the depths has been particularly discussed, on account of its utility in finding the contents for actual contract-work from the working drawings, in which, as great accuracy is required, the contents should be found to two places of decimals, or to  $\frac{1}{100}$ ths of a foot in the depths, as in Case II. of the following Problem.

2. When one or both of the given depths exceed the limits of the table, find the content corresponding to half the two depths, and four times the result will be the content required.



PROBLEM VIII.

CASE I.

To find the content of a cutting between two cross-sections, the areas of which, in the intersection of the slopes, the length, the bottom width, and the ratio of the slopes, are given.

RULE.—Find the square roots of the given areas either by a table of square roots, or by actual extraction ; with these roots, as depths, proceed to find the content from the General Table, as in Problem VII., from which deduct the quantity corresponding to the given bottom width and ratio of slopes from Table No. 1, and multiply the remainder by the length for the content.

NOTE. If the length be given in feet, multiply the content found by the above rule by the feet, and divide by 66 for the content.

Ex. 1. Let the areas of the two ends of a cutting be 5141 and 1444 square feet, the bottom width 30 feet, the length 1·60 chains and the ratio of the slopes  $1\frac{1}{2}$  to 1 ; required the content of the cutting in cubic yards.

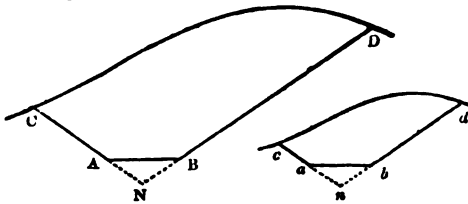

Let the annexed figures be the two cross-sections, the side slopes CA, DB ; ca, db, being prolonged till they meet at N and n, the area  $CND = 5141$ , the area  $cnd =$

1444 ; and since the bottom width  $AB = ab$ , and the ratio of the slopes are given, the solidity of the prism, the ends of which are  $ABN = abn$ , is given in Table No. 1, and is to be deducted from the content found by the General Table as in Problem VII.

The square roots of 5141 and 1444 are	71·7 and 38
By General Table, for 71 and 38	7483
By Table No. 2, for $\frac{(71 \times 2) + 38}{10} = 18$ and $\cdot 7$	103
Content to intersection of slopes	<u>7586</u>
By Table No. 1, for bottom width 30, and slopes $1\frac{1}{2}$ to 1	366·67.
Content for 1 chain in length	<u>7220·33</u>
	1·60
Content for 1·60 chains in length	<u>11552·528</u>
	cubic yards.

## CASE II.

When great accuracy is required, especially in the measurement of contract work, the second decimals, or  $\frac{1}{100}$ ths, of feet, must be considered in the calculation by taking for them  $\frac{1}{100}$ th of their corresponding quantities in Table No. 2.

Ex. Let the areas of the several cross-sections to the intersection of the slopes, and their distances, be as in the annexed table, the bottom width 36 feet, and the ratio of the slopes  $1\frac{1}{2}$  to 1; required the content of the cutting in cubic yards.

Dist. in Chains.	Areas in Sq. ft.	$\sqrt{\text{Areas}}$	Product.	Contents.
0	2161	46.59		
1.00	3759	61.31	—	7147
2.00	5141	71.7	—	10832
4.20	4100	64.03	11271 $\times$ 2.20	24796
6.00	4221	64.97	10170 $\times$ 1.80	18306
8.00	3136	56.	8959 $\times$ 2.00	17918
9.00	2727	52.22	—	7160
				86159
From Table No. 1 for bottom width 36 ft. and slopes $1\frac{1}{2}$ to 1, $528 \times 9.00$				} 4752
Content in cubic yards . . . . .				

## PROBLEM IX.

To find the content of a railway cutting when the slopes of the two sides are different.

## CASE I.

When the depths are given.

RULE.—Find the content by the tables, as in the two preceding Problems, multiply the result by half the sum of the side slopes, and from the product deduct half the sum of the cubic yards, corresponding to the given bottom width and the ratios of the slopes of the two sides, multiplied by the whole length of the cutting, and the remainder is the content in cubic yards.

Ex. Let the depths and their distances be as in the annexed table, the bottom width 36 feet, and the ratios of the slopes of the two sides 1 to 1 and  $1\frac{1}{2}$  to 1; required the content of the cutting.

NOTE.—Here the half sum of the first terms of the ratios of the slopes, viz.  $\frac{1}{2}(1 + 1\frac{1}{2}) = 1\frac{1}{4}$  is the number by which the sum of the quantities, per tables, is to be multiplied, or  $\frac{1}{4}$  added, as in the operation; and half the sum of the cubic yards, for the given bottom width and ratios of the two slopes, is multiplied by the whole length of the cutting, and deducted, agreeably to the rule.

Dist. in Chains.	Depths.	Qts. per Tables.
0	61	
1.00	52	7820
2.00	44.46	5473
For slopes 1 to 1 . . . . . 13293		
" $\frac{1}{2}$ to 1 . . . . . 3323.25		
16616.25		
$\frac{1}{2}(528 + 792) \times 2 . . . . . 1320$		
Content . . . . . 15296.25		

## CASE II.

*When the sectional areas are given.*

RULE.—Find the content from the tables as in Problem VIII. and deduct for the quantity below the cutting, as in Case I. of this Problem.

NOTE.—This rule seems too obvious to require an example.

## PROBLEM X.

*To apply the General Table and Table No. 2 to such bottom widths and ratios of slopes as are not found in Table No. 1.*

Put  $w$  = bottom width, and  $r$  to 1 the ratio of slopes.

Then  $\frac{w}{2r}$  = feet to be added to depth of cutting, or distance from bottom of cutting to the intersection of slopes.

And  $\frac{11w^2}{18r}$  = cubic yards to be deducted for each chain in length.

EX. If the bottom width be 28 feet, and the ratio of slopes  $1\frac{1}{4}$  to 1; then  $w \div 2r = 28 \div (2 \times 1\frac{1}{4}) = 11\frac{1}{2} = 11.2$  feet = distance from bottom of cutting to intersection of slopes, and  $11w^2 \div 18r = 11 \times 28^2 \div 18 \times 1\frac{1}{4} = 383.29$  cubic yards to be deducted for each chain in length.

## PROBLEM XI.

*To find the content of the cutting of a tunnel.*

1. *When the length is given in yards, and the width and height in feet.*

RULE.—Multiply continually together the length, width, and mean height, and divide the product by 9.

2. *When the length is given in chains, and the width and height in feet.*

RULE.—Multiply the continued product of the length, width, and mean height by 22, and divide by 9.

EX. The length of cutting of a tunnel is 1053 yards, its width 30 feet, and mean height 32 feet; required the content.

$$\frac{1053 \times 30 \times 32}{9} = 11232 \text{ cubic yards.}$$

*The following example shows the magnitude of the errors of several methods, sometimes used, for calculating the contents of cuttings.*

EX. The areas of the two cross-sections of a cutting, to the

intersection of the slopes, are 10324 and 400 square feet, their distance 4 chains, the bottom width 36 feet, and the ratio of the slopes 1 to 1; required the content of the cutting by the General Table, &c., and by the erroneous methods sometimes used.

NOTE.—The great difference of the sectional areas in this example shows very prominently the errors of several methods of finding the contents of cuttings: at the same time it is proper to remark that similar differences in the sectional areas very frequently occur in practice, and that the erroneous methods give the contents very near the truth *only* when these areas are nearly equal.

$$\left. \begin{array}{l} \sqrt{10324} = 101.607 \\ \sqrt{400} = 20 \end{array} \right\} \text{Content by General Tab., \&c. } 10394$$

Deduction from Tab. No. 1 . . . . .	792
Content for 1 chain in length . . . . .	9602
	4

True content for 4 chains in length . . . . .	38408 cub. yds.
---	-----------------

*By Mr Bashforth's Method.*

(1.) By Table No. 1 the depth below the formation-level to the meeting of the slopes is 18 ft.; hence the area of the triangle below it is  $\frac{1}{2} (36 \times 18) = 324$  square feet, which deducted from the given sectional areas, gives 10000 and 76 sq. ft. for the sectional areas, as used by Mr Bashforth.

$$\left. \begin{array}{l} \text{Whence } \sqrt{10000} = 100 \\ \sqrt{76} = 8.718 \end{array} \right\} \text{Content by Gen. Tab. \&c. } 8920.4$$

Content for 4 chains in length . . . . .	35681.6 c. y.
--	---------------

<i>Error in defect, compared with the true content) given above, being above 7½ per cent., by Mr B.'s method.</i>	2726.4
---	--------

(2.) *By taking a mean of the areas for a mean section.*

$\frac{1}{2} (10000 + 76) \times \frac{22}{4} \times 4 = 49260.4$  cubic yards; which exceeds the true content by 10852.4 cubic yards, being above 22 per cent. in excess.

(3.) *By taking a mean depth the error in defect is just half of the preceding error, or nearly 11 per cent.*

OBSERVATIONS IMPORTANT TO THOSE CONCERNED IN THE CONSTRUCTION OF RAILWAYS, ON THE ERRONEOUS METHODS OF CALCULATING THE CONTENTS OF CUTTINGS, WHERE THE SURFACE OF THE GROUND IS UNEVEN; ALSO ON THE METHOD GIVEN IN THIS WORK.

The magnitude of the errors of the methods (1), (2), and (3), in the last example, for calculating the contents of cuttings, where the surface of the ground is uneven, from sectional areas, is strikingly apparent; and since many tables are not accompanied by any directions for their practical application in this particular case, one or other of the last two of these defective methods is still frequently used by engineers and contractors; thus causing continual disputes concerning the contents in consequence of the different parties using irreconcilable methods, some preferring one and some the other, as giving, in their respective judgments, the *true* content.

It is therefore the interest of those concerned in the construction of railways to adopt the method given in this work for finding the contents of cuttings, where the surface of the ground is laterally sloping, &c., as no other method combining all attainable mathematical accuracy has, to my knowledge, been yet published: those already published referring only to cuttings where the surface of the ground is either level, or the sections thereof assumed to be reduced to a level, which, in many cases, is a work of great labour to perform accurately. See the following investigations.

INVESTIGATION OF THE CONSTRUCTION AND USE OF THE GENERAL AND AUXILIARY TABLES, AND OF THE ERRORS OF OTHER METHODS.

Let  $ABDC$ ,  $abcd$ , be vertical cross-sections of a railway cutting, the surface widths  $CD$ ,  $cd$ , being horizontal,  $ACca$ ,  $BDdb$ , the side-slopes,  $AB = ab$  the bottom width. Prolong the planes of the side slopes downwards and to the left till they meet in  $N\alpha V$ , and also meet the prolongation of the plane  $CDdc$  in  $cV$ ,  $dV$ . Because  $AB = ab$ , the cross-sections are  $\perp$  to  $VN$ . Let fall the  $\perp$   $NM$ ,  $nm$  on  $CD$ ,  $cd$  respectively, bisecting them in  $M$  and  $m$ , and also bisecting  $AB$ ,  $ab$  in  $M'$  and  $m'$ . Put  $MN = a$ ,  $mn = b$ ,  $Nn = Aa = Bb = l$ ,  $AB = ab = w$ , all in feet, and the ratio of the slopes, *i.e.*,  $CM : MN :: r : 1$ . Then

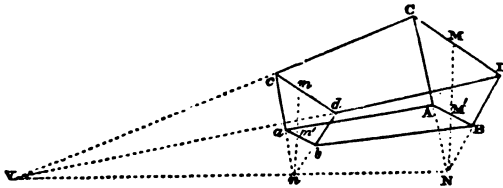

$\Delta CDN = a^2r$ ,  $\Delta cdn = b^2r$ . By similar figures  $a : b :: NV : NV - l$ ,  
whence  $NV = \frac{al}{a-b}$ ;

$$\text{Pyramid } vCND = \frac{1}{3} NV \times a^2r.$$

$$\dots \dots vcdn = \frac{1}{3}(NV - l)b^2r; \text{ whence}$$

$$\text{Frustum } CDNncd = \frac{1}{3} NV \times a^2r - \frac{1}{3} (NV - l) b^2r = \frac{1}{3}r (a^2 - b^2NV + b^2l) =$$

(by substituting the value of NV)

$$\frac{1}{3}rl(a^2 + ab + b^2) \text{ cubic feet}$$

$$= \frac{rl}{81} (a^2 + ab + b^2) \text{ cubic yards} \quad \dots \quad (1)$$

In the General Table  $r = 1$ , and  $l = 1$  chain = 66 feet; and  $\therefore$  the solidity

$$S = \frac{22}{27} (a^2 + ab + b^2) \text{ cubic yards} \quad \dots \quad (2)$$

wherein  $a$  and  $b$  have all integral values from 0 to 72.

*Auxiliary Table No. 1.*

$$r : 1 :: \frac{1}{2} w (= AM') : NM' = \frac{w}{2r} \quad \dots \quad (3)$$

$$\text{whence } \Delta ABN = \Delta abn = \frac{1}{2} AB \times NM' = \frac{w^2}{4r} \quad \dots \quad (4)$$

$$\therefore \text{Prism } ABNnab = \frac{w^2l}{4r} \text{ sq. ft.} = \frac{w^2l}{108r} = \text{cubic yds.} \quad \dots \quad (5)$$

From (3) and (5) the depths to be added, and the cubic yards to be deducted in Table No. 1, are calculated, by taking  $l = 66$  feet, and  $w$  and  $r$  all the values most commonly used in practice.

$$\therefore \frac{w^2l}{108r} = \frac{11w^2}{18r} = \text{cubic yards to be deducted, Table No. 1.} \quad \dots \quad (6)$$

$$\therefore \frac{11w^2L}{18r} = \text{cubic yards to be deducted for the length } L.$$

Let  $\Sigma =$  sum of all the solidities  $s, s', \&c.$  (per General Table), the length of which is  $L$ , and  $\kappa = \frac{Hw^2}{18r}$  from (6), then  $\Sigma r =$  sum of solidities for slopes  $r$  to 1, from which deduct  $\kappa \times L$ , and there results

$$\Sigma r - \kappa L = \text{cubic yards in the whole cutting} \quad \dots \quad (7)$$

Whence the method of finding the contents of cutting in Problem VII.

Cor. 1. The content of a cutting having only two given depths is  $(\Sigma r - \kappa)L$  cubic yards.  $\dots \dots \dots (8)$

Cor. 2. If the ratio of the slopes of the two sides of a cutting be  $r$  to 1 and  $\rho$  to 1, and  $k, \kappa$  the corresponding cubic yards to be deducted. (Table No. 1.)

$$\frac{1}{2} \{ \Sigma (r + \rho) - L(k + \kappa) \} \text{ cubic yards.}$$

Let in (2)  $a$  and  $b$ , hitherto supposed to be integral numbers, have the increments or decimals  $\alpha$  and  $\beta$ , so that  $a$  and  $b$  become respectively  $a + \alpha$  and  $b + \beta$ , which being substituted for  $a$  and  $b$ , neglecting the squares and product of  $\alpha$  and  $\beta$ , as being comparatively small, there results :

$$\frac{22}{27}(a^2 + ab + b^2) + \frac{22}{27}(2a + b)\alpha + \frac{22}{27}(2b + a)\beta \quad . \quad . \quad . \quad (9)$$

By subtracting (2) from (9), there results the sum of

$$\frac{22}{27}(2a + b)\alpha \text{ and } \frac{22}{27}(2b + a)\beta, \text{ or}$$

$$\frac{22}{27} \left( \frac{2a + b}{10} \right) 10\alpha \text{ and } \frac{22}{27} \left( \frac{2b + a}{10} \right) 10\beta \quad . \quad . \quad . \quad (10)$$

which are the increments of the formula (2) arising from the addition of the decimal parts  $\alpha$  and  $\beta$  to the depths  $a$  and  $b$ , from which Table No. 2 has been calculated, the quantities  $2a + b$ , and  $2b + a$  being divided by 10, to prevent a too great extension of the Table ; and the corresponding factors  $\alpha$  and  $\beta$  multiplied by the same number, that the product might retain their original value, the decimal points being still affixed to the values of  $\alpha$  and  $\beta$  in the horizontal line at the top of the Table.

In consulting Table No. 2 the nearest whole numbers to  $\frac{2a + b}{10}$  and  $\frac{2b + a}{10}$  are taken as the small errors, thus resulting, will usually balance one another in a long cutting, and can never in any case amount to much.

Let the plane  $VCD$  revolve on the side  $VC$ , so that the lines  $CD, cd$  may incline from their hitherto assumed horizontal position, thus making the side slopes unequal ; and let the area  $CDN = A$ , and the area  $cdn = B$ , the other symbols being the same as before ; then

$$\sqrt{A} : \sqrt{B} :: VN : VN - l, \text{ whence } VN = \frac{l\sqrt{A}}{\sqrt{A} - \sqrt{B}}.$$

Pyramid  $VCDN = \frac{1}{3} VN \times A$ , Pyramid  $vcn = \frac{1}{3} (VN - l) \times B$ , whence

the frustum  $CDNncd = s = \frac{1}{3} VN \times A - \frac{1}{3} (VN - l) \times B = \frac{1}{3} (\overline{A - B} \times VN + Bl)$ ,

$$\text{or } s = \frac{1}{3} l (A + B + \sqrt{A \times B}), \text{ in cubic feet, and taking } l = 66 \text{ feet} \\ = \frac{22}{27} (A + B + \sqrt{A \times B}) \text{ cubic yards . . . . . (11)}$$

Therefore the Table must be consulted for depths  $\sqrt{A}$  and  $\sqrt{B}$ , the ratio of the slopes being included; for if  $a$  and  $b$  be the mean depths for the areas  $A$  and  $B$  respectively, the slopes being  $r$  to 1, then

$$a^2 r = A, \quad b^2 r = B \quad \text{and} \quad \frac{22}{27} (A + B + \sqrt{A \times B}) = \frac{22r}{27} (a^2 + ab + b^2).$$

Therefore in reality the Table is consulted for the depths  $a \sqrt{r} = \sqrt{A}$ , and  $b \sqrt{r} = \sqrt{B}$ .

If  $\Sigma'$  = sum of all the solidities  $s, s', \&c.$ , for depths  $\sqrt{A}$  and  $\sqrt{B}$ ,  $\&c.$ , and length  $L$ ; then by subtracting  $\kappa L$ , as in (7), there results  $\Sigma' - \kappa L$  cubic yards in the whole cutting . . . . . (12)

Whence the Rule in Problem VIII.

Cor. 1. The content of a cutting, having only two given sectional areas, is  $(s - \kappa) L$  cubic yards . . . . . (13)

Cor. 2. Formulæ (11), (12), and (13) will evidently hold, if, instead of the straight lines  $CD, cd$ , being the surface edges of the cross-sections.  $CDN, cdn$ , of the cutting, these lines be the chords of similar curves forming the surface edges of the cross-sections, and the similarly situated points in the two curves be joined by right lines (which prolonged will all meet in the vertex  $V$ ), thus forming the surface of the cutting, a necessary condition in taking cross-sections; or the small inequalities of the earth's surface between the cross-sections must be balanced, as nearly as can be judged by the eye, so that the surface may fulfil this condition, in order that all attainable mathematical accuracy may be arrived at in finding the contents.

#### THE ERRORS OF OTHER METHODS OF FINDING THE CONTENTS OF RAILWAY CUTTINGS.

Mr Bashforth, in his investigations for finding the contents of railway cuttings, where the surface of the ground is level, or assumed to be so, includes the prism  $ABNnba$ , and afterwards deducts it which is mathematically accurate. But in finding the contents from sectional areas, where the surface of the ground is laterally sloping,



or uneven, he altogether leaves out the above-named prism ; for he says (Art. 15, p. 11 of his work), "The only way to proceed in such a case is—find the areas of the cross-sections in square feet, take out of Barlow's Tables the square root of each, and treat these square roots precisely as if they had been measured heights, excepting that there will be nothing to be deducted for the prism, and no multiplication for the slopes, these having been already accounted for in finding the areas."

Let  $A'$  and  $B'$  be the sectional areas  $CDBA$ ,  $cdba$  respectively, as used by Mr B., and  $l = Nn =$  length of the cutting (fig. page 452), then according to his method, the content of the cutting is

$$\frac{l}{81} (A' + \sqrt{A' \times B'} + B') \quad . \quad . \quad . \quad . \quad . \quad . \quad (14)$$

which is erroneous in every case, except where the areas represented by  $A'$  and  $B'$  are similar and equal. For when the equal areas  $ABN$ ,  $abn$  are omitted, the areas represented by  $A'$  and  $B'$  are dissimilar, and  $\therefore$  the proportion  $\sqrt{A'} : \sqrt{B'} :: NV : nV$ , on which Mr B.'s rule is founded, does not hold, it being true only in respect to the areas  $CDN$ ,  $cdn$ , because the solids  $VCDN$ ,  $vcdn$  are similar. Moreover, if the plane  $VCD$  revolve on the side  $CD$  so as to bring the lines  $cd$ ,  $ab$ , to coincidence, or almost to coincidence, in the points  $b$  and  $d$ , the dissimilarity of the planes  $CDBA$ ,  $cdba$  will become more strikingly evident, whereas with the addition of the  $\Delta S$   $ABN$ ,  $abn$ , they still remain similar.

Let  $\Delta ABN = abn = \alpha$ , then  $A' + \alpha$  and  $B' + \alpha$  are the sectional areas corresponding to  $A$  and  $B$  in formula (11) of my investigation, whence by that formula the true content, including the prism  $ABNnba$ , is

$$\frac{l}{81} (A' + B' + 2\alpha + \sqrt{A' + \alpha \times B' + \alpha}) \text{ cubic yards.}$$

But the solidity of the prism is  $\frac{al}{27} = \frac{3al}{81}$  cubic yards.

Whence the content of the prismoid or cutting is

$$\frac{l}{81} (A' + B' + 2\alpha + \sqrt{A' + \alpha \times B' + \alpha} - 3\alpha), \text{ or}$$

$$\frac{l}{81} (A' + B' + \sqrt{A' + \alpha \times B' + \alpha} - \alpha),$$

from which subtract the content according to Mr B. (14), and there results.

$$\frac{l}{81} \sqrt{A' + \alpha \times B' + \alpha} - \sqrt{A' \times B'} - \alpha = \text{error in defect.}$$

Let  $A' = \frac{1}{4}\alpha$ , and  $B' = 36\alpha$ , which is a case that may occur in practice, then

$$\frac{l}{81}(\sqrt{A' + \alpha \times B' + \alpha} - \sqrt{A' \times B'} - \alpha) = \frac{al}{81}(\frac{1}{2}\sqrt{185} - 3 - 1)$$

$$= \frac{al}{81} \times 2.8007 = \text{error in defect by Mr B.'s method.}$$

$$\text{and } \frac{l}{81}(A' + \sqrt{A' \times B'} + B') = \frac{al}{81}(\frac{1}{4} + 3 + 36) = \frac{al}{81} \times 39\frac{1}{4} =$$

whole content by Mr B.'s method.

$$\therefore \text{ whole content : error in defect : : } \frac{al}{81} \times 39\frac{1}{4} : \frac{al}{81} \times 2.8007$$

$$39\frac{1}{4} : 2.8007$$

$$100 : 7\frac{1}{4}, \text{ or } 7\frac{1}{4} \text{ per cent.}$$

the error in defect . . . . . (15)

See Ex. at the end of Problem X., where the error of Mr Bashforth's method is shown by giving actual areas.

NOTE.—The errors of this method are not so prominent where the sectional areas approach near to equality, as in the case of the Burnley cross-sections, in the Ex. Art. 20, page 13, of Mr B's work: his method, however, is erroneous to a greater or lesser extent, in every case, except where the sectional areas are equal and similar; for they cannot be similar without being equal, while the bottom width remains the same.

Mr Bashforth says, in defence of his method of finding the contents of cuttings from sectional areas, in the "Mechanics' Magazine" for Sept. 11, 1847, p. 249, "In the case of contract estimates, numerous cross-sections ought to be taken; and it matters little whether we start from the intersection of the slopes or the formation-level." *The above-noticed error (15) shows that it "matters" so much as 7¼ per cent. in defect.* Besides, there is no need of taking "numerous cross-sections," as Mr B. recommends, especially where the surface of the ground is laterally sloping like a geometrical plane, or curved like a conical surface, one or other of which cases very frequently occurs, so that cross-sections, taken at a considerable distance from one another to the intersection of the slopes, may be considered as similar, or so very nearly so as not to induce any important mathematical error, which conditions may be easily determined by the eye. Moreover, the expense and trouble of taking "numerous cross-sections," plotting them, and finding their areas, are very considerable; and, therefore, ought to be avoided, together with all erroneous methods, such as Mr B.'s, of finding the contents of cuttings, as his

“numerous cross-sections” only tend to diminish the errors, without wholly getting rid of them.

*The error of the method of finding contents by mean areas.*

Let  $A$  and  $B$  be the areas of two cross-sections of a cutting to the intersection of the slopes, and  $l$  its length: then the mean area is  $\frac{1}{2}(A+B)$ , and the content in cubic yards is  $\frac{1}{27}l \times \frac{1}{2}(A+B) = \frac{1}{54}l \times \frac{3}{2}(A+B)$ ; from which subtract the true content, equation (11), p. 455, and there results

$$\frac{1}{54}l \left\{ \frac{3}{2}(A+B) - (A+B+\sqrt{AB}) \right\} = \frac{1}{108}l (\sqrt{A} - \sqrt{B}) = \text{error in excess.}$$

Which error is very great when the areas  $A$  and  $B$  differ considerably. See (2), p. 451.

*The error of the method of finding the content by mean depth.*

Let  $a$  and  $b$  be the depths of two cross-sections to the intersection of the slopes, the ratio of which is  $r$  to 1, and  $l$  = length of the cutting; then  $\frac{1}{2}(a+b)$  = mean depth,  $\frac{1}{4}r(a+b)^2$  = mean area, and the content in cubic yards =  $\frac{1}{27}l \times \frac{1}{4}r(a+b)^2 = \frac{1}{54}rl \times \frac{3}{4}(a+b)^2$ ;

which subtract from equation (1), p. 411, and there results

$$\frac{1}{54}rl \left\{ a^2 + ab + b^2 - \frac{3}{4}(a+b)^2 \right\} = \frac{1}{81}rl (a-b)^2 = \text{error in defect:}$$

Which error is very considerable, when the depths  $a$  and  $b$  differ greatly.

NOTE.—The errors of these methods, as here shown, are the same as if the areas and depths had only extended to the formation-level, since a common quantity, i.e. the prism below the formation-level, is here included, and afterwards excluded, by taking the differences.

## SECTION V.

### TUNNELLING.

(1.) Previous to setting out the earthwork of a tunnel, the levelling operation must be repeated with great care, and should also be checked by the method given in Art. (22), Section I., especially if the tunnel pass under a very high summit: for, if the section be incorrect, the gradient or gradients, on which the tunnel is formed, will not meet at the points shown thereon, and thus embarrass the mining operation.

(2.) If the tunnel is formed on one gradient, as  $BD$ , Plate XIII.

the gradient must incline to one of the extremities of the tunnel, as at D, in order to discharge the water generated therein. Strong poles or masts must be firmly fixed on the surface, in the intended direction of the tunnel, of which one must be on the summit of the hill; at which place a temporary observatory is frequently erected, especially if the summit be a very high one, and the tunnel a very long one. Shafts must be sunk at the distance of four or five chains from one another, in the direction of the poles (and observatory, if there be one), in order to ventilate the tunnel, as well as to check the accuracy of the work as it proceeds. If the tunnel be a long one, it would be preferable, if convenient, to form it on two gradients, inclining to its opposite extremities to liberate the water, and thus to aid the mining operation, which is commonly commenced at both ends of the tunnel at the same time.

(3.) When it is necessary to have a curve in the direction of a part or of the whole of the tunnel, that direction must be carefully laid down on the surface, by the methods given in Section III., making allowance for acclivities and declivities, poles or masts being fixed therein, as pointed out in Art. (2), that the shafts may be sunk so as to meet the mining operations of the tunnel, as well as to check their accuracy in point of direction, and this will be the more especially necessary in the curved part of the tunnel.

(4.) The mining operation of the tunnel should commence when the depth of the cuttings at each end is about 60 feet. The width and depth of the excavation of a tunnel, on the narrow gauge, should be about 30 feet each, and must be dug 5 or 6 feet below the intended line of the rails, to give space for the inverted arch and the ballasting, excepting where the excavation is made through rock sufficiently hard to form the side-walls of the tunnel, in which case 22 or 24 feet in width, and about 26 feet in height, will be sufficient, the excavation in this case being terminated below by the balance-line, or formation-level. The depth and width of the excavation for a tunnel on the broad gauge must, in both cases, be proportionately larger.

The annexed figure is a cross-section of the masonry of a tunnel, which, of course, is such as is required where the tunnel is made through loose earth, only the arch above being required when made through hard rock.

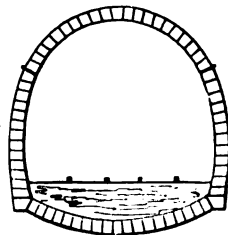

NOTE.—The remarks at Articles (25) and (27), Section II., refer only to the projection of tunnels on parliamentary maps.

A TABLE OF THE DIMENSIONS OF SEVERAL EXISTING TUNNELS.

Names of Railways and of Tunnels.	Length in Yards.	Width in Feet.	Height in Feet.	Shafts.	
London and Bir- mingham	Primrose Hill	1120	22	22	5
	Weedon . . .	418			
	Kilsby . . .	2398			10
Cromford and High Peak—Buxton	580	21	16		
Great Western—The Box Tunnel	3227	35	29	13	
Manchester and Leeds	Littleborough .	2869	24	21½	
	North Midland				
North Midland	Claycross . .	1806	22	21	
	Melford . . .	836			
London and Brighton	Merstham	1780			
	Balcombe	1192			
Sheffield and Manchester	Five tunnels }	6245			
	Total length }				
Chester and Holyhead	Three tunnels }	2130			
	Total length }				
South-Western	Seven tunnels }	1998			
	Total length }				

## SECTION VI.

## VIADUCTS, AQUEDUCTS, SKEW ARCHES, ETC.

What are here given on these subjects are necessarily only outlines, referring to some few existing structures, without entering into the details of specifications, working drawings, &c., which are foreign to the nature of this work, and properly belong to the department of the architect.

*Railway Viaducts.*—It would be impossible to enumerate the whole of the viaducts constructed since the introduction of railways. Structures in timber, brick, stone, and iron, of various designs, have been erected; and in some cases there is a novelty of principle accompanied with great boldness of execution.

*The Brick Viaduct at Maidenhead*, constructed by Mr Brunel for the Great Western Railway, is one of the best examples in that material: it is composed of two elliptical arches spanning the Thames, each 128 feet, with a versed sine of  $24\frac{1}{2}$  feet; the pier between the two arches is 30 feet in width. The arch in the middle is  $5\frac{1}{4}$  feet in thickness, which gradually increases towards the abutments. Besides these two grand brick arches, on each bank of the

river are four others ; those on the abutments span 21 feet each, and the six others 28 feet each.

*The Viaduct over the Ouse, near York*, consists of three arches, each 66 feet span ; the piers are 10 feet in thickness, and the width of

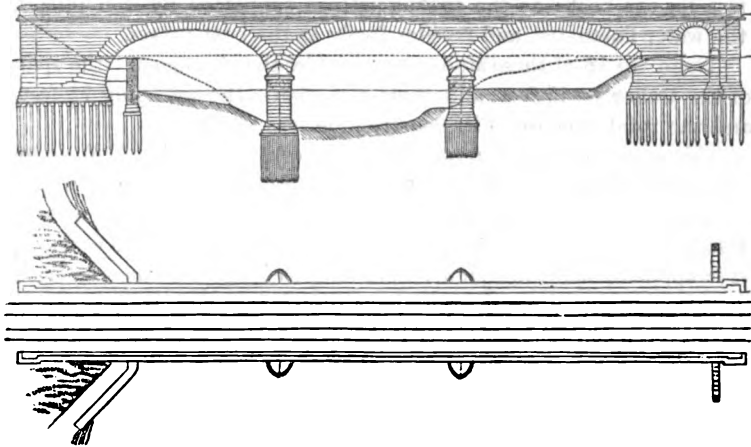

the arches  $28\frac{1}{2}$  feet on the soffit, and their thickness at the keystone  $3\frac{1}{2}$  feet, the voussoirs gradually increasing towards the springing.

This is a specimen of a stone viaduct combining great strength and elegance in its construction.

*Aqueduct of Pont-y Cysyllte* is 4 miles from Chirk, over the river Dee ; its length is 1007 feet, and the river is 127 feet below the water-level of the canal carried over it.

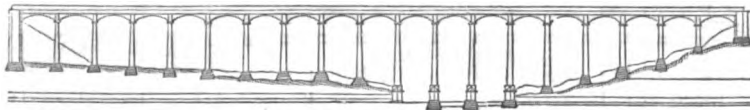

To construct an aqueduct upon the usual principles, with piers and arches above 100 feet in height, and of a sufficient breadth and strength to afford room for a puddled water-way, would have been not only expensive but extremely hazardous. Telford, who had already carried the Shrewsbury canal by a cast iron trough 16 feet above the level of the ground, formed the idea of doing the same in the present instance, which was approved and finally adopted. The foundation on which the piers are erected is a hard sandstone ; their height above low water in the river is 121 feet : at the bottom they are 20 feet by 12, at the top 13 feet by  $7\frac{1}{2}$ . For a height of 70 feet above

the foundations, they are built solid, and the remaining 50 feet hollow, the walls being only 2 feet in thickness, with one cross inner wall; by this means the centre of gravity of the piers is thrown lower, and the masonry economised. The width of the water-way is 12 feet; of which the towing-path covers  $4\frac{1}{2}$  feet, leaving  $7\frac{1}{2}$  feet for the boat: as the towing-path is supported by iron pillars, the water fluctuates, and recedes freely as the boat passes.

There are 18 of these stone piers, besides the abutments; the span of the arches is 45 feet, and their rise above the springing  $7\frac{1}{2}$  feet, and the total expense of its construction was 47,018*l*.

This aqueduct almost rivals the works of a similar kind left us by the ancient Romans: the introduction of iron, however, for a water-course, is a novelty with which they were unacquainted: in this instance it has proved admirably well fitted for the purpose to which it is applied: had the channel been constructed with stone or brick at this great elevation, it would have been less secure, as there would have been a constant danger of leakage.

#### SKEW OR OBLIQUE BRIDGES.

One of the skew bridges on the *London and Birmingham line*, a fine erection of this kind, is  $23\frac{1}{2}$  feet in height from the surface of the road below to that of the rails, making an angle of  $32^\circ$  with the road: the direct span of the arch is 21 feet, and oblique span 40. The arch, which is  $2\frac{1}{2}$  feet thick, is the segment of a cylinder, the internal radius of which is  $12\frac{1}{2}$  feet, and the versed sine  $5\frac{3}{4}$  feet. The angle of which the coursing joints of the soffite cross the axis of the cylinder is  $53^\circ 25'$ , and the joints of the face of the arch all converge to a point  $32\frac{1}{2}$  feet below the axis of the cylinder, and 45 feet below the crown of the arch.

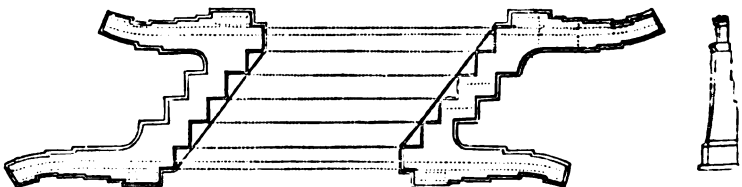
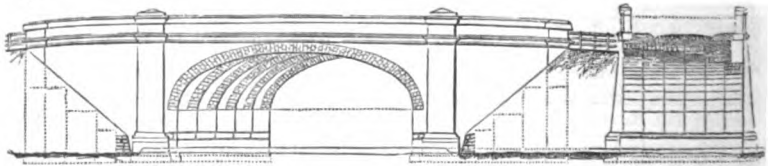

The *Midland Counties Railway* possesses another variety of skewed brick bridge, the span of which is  $42\frac{1}{2}$  feet, and versed sine 11 feet;

the arch consists of six ribs, 2 bricks in depth, and 4 feet in thickness, the total breadth of the bridge, measured at right angles to the face, being 24 feet.

*Manchester and Birmingham Railway.*—In Fairfield Street is a skew bridge, the oblique span of which is  $128\frac{3}{4}$  feet, with a versed sine of 12 feet; the width from face to face is 31 feet.

Six ribs of iron abut on as many independent walls, and project before each other 13 feet; an ornamental stone parapet and cornice crown this viaduct, presenting a novel and agreeable appearance.

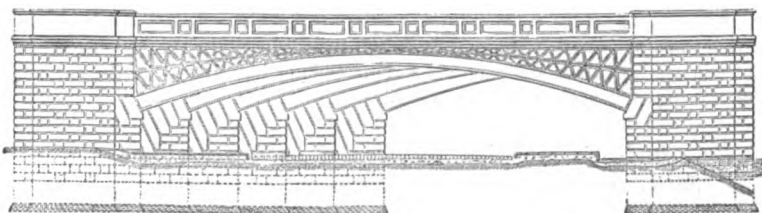

This bridge, executed after the designs of Mr. G. W. Buck, is remarkable for its acute angle, which is  $24\frac{1}{2}^\circ$ . The weight of the iron-work employed on the six ribs was 540 tons, and the whole was admirably secured together; the remainder of the viaduct is formed with brick arches of 45 feet span.

#### DIMENSIONS OF VIADUCTS IN VARIOUS RAILWAYS.

*In the Grand Junction Railway*, at Vale Royal, is a viaduct of stone over the river Weaver, in which are five arches, each 63 feet in span and 60 in height; the length of the viaduct is 456 feet. Where this railway crosses the Mersey and Irwell Canal there is a viaduct of stone having 12 arches; the two in the centre are 75 feet in span, and the remainder from 40 feet to  $12\frac{1}{2}$ .

*In the Newcastle and Carlisle Railway*, near Brampton, is a viaduct, which crosses the public road and the river Gelt, at the height of 80 feet above the bed of the river, over which it is carried in an oblique direction. The arches, which are three in number, are 33 feet in direct span, and are built at an angle of  $45^\circ$ .

*In the Birmingham and Derby Junction Line*, between Kingsbury and Tamworth, over the Anker, is a viaduct of 18 arches, each of 30 feet span, and one oblique arch of 60 feet span; its height above the river is 23 feet, and the cost was 18,000*l.* *In the same line*, between Tamworth and Burton-on-Trent, is a viaduct  $\frac{1}{4}$  mile in length, built upon above 1000 piles, driven 15 feet below the bed of the river.

*In the Newcastle and Shields Railway* there is a viaduct over the Ouseburn of 9 arches, two of which at the ends are of stone, and the others are of timber, resting on stone piers; the three central arches have each a span of 116 feet, and two others 110; the total length of the viaduct is 750 feet, and its height above the water 180 feet. *In the same line*, the viaduct at Willingdon Dean has 7 timber



arches, five of which span 120 feet each, and the two exterior each 115 feet; the whole length is 1050 feet, and the height 82 feet.

*In the Taff Vale Railway*, near Quaker's Yard, is a viaduct crossing the Taff, the length of which is 600 feet, and the height above the river 100 feet, having 6 arches. *In the same line*, at the conflux of the Rhondda and Taff, is a viaduct having an arch of 100 feet span, and 60 feet in height.

*In the London and Brighton Railway*, across the valley of the Ouse, is a viaduct 1437 feet in length, and the height varies from 40 to 96 feet; it is formed of 37 brick arches of 30 feet span.

*The London and Greenwich Railway* is a continuous viaduct of more than 1000 brick arches, each 18 feet span, 22 feet in height, and 25 feet in width. It is  $3\frac{1}{2}$  miles in length, and cost 266,322*l.* per mile.

*The extension of the South-Western Railway* through the metropolis, from the Nine Elms to Waterloo Bridge, is a continuous viaduct, like the last-mentioned one, in which are several strong and elegant oblique iron arches for the purpose of crossing some of the principal streets.

The student's attention should also be directed to the many magnificent railway bridges and viaducts of *iron* which have been erected of late years; such as the *Britannia and Conway Bridges* in North Wales; the *High Level Bridge* at Newcastle-on-Tyne; and the great *Victoria Bridge* in Canada by Mr Robert Stephenson; the *Windsor, Chepstow, and Saltash* bridges by Mr Brunel; the new *Charing Cross Bridge* by Mr Hawkshaw; and the *Viaduct at Crumlin* in Monmouthshire, by Messrs Kennard. Descriptions of these will be found in engineering works.

I shall conclude this section by recommending to those who wish for scientific and practical information of the first order on this subject, "The Theory, Practice, and Architecture of Bridges," by J. Hann and others; "Practical and Theoretical Essay on Oblique Bridges," by G. W. Buck, M. Inst. C.E.; "Treatise on the Equilibrium of Arches," by Joseph Gwilt, architect, F.S.A.; Cressy's "Encyclopædia;" and a "Practical Treatise on the Construction of Oblique Arches," by J. Hart.

## SECTION VII.

### SUPERELEVATION OF EXTERIOR RAIL IN CURVES.

The superelevation of the exterior rail in curves, the radii of which are within certain limits, is absolutely necessary to counteract the centrifugal force caused by the velocity of the train, since all moving bodies have a tendency to continue their motion in a direct line. From this cause the carriages of a railway train are driven towards the exterior rail, and would finally be thrown off the rails,

were it not for the conical inclination of the tire and the flanges of the wheels.

Let  $w$  = weight of the moving body or train,  $v$  = its velocity per second,  $R$  = radius of the curve, and  $g$  = force of gravity at the earth's surface ; then, by Dynamics, the centrifugal force

$$f = \frac{wv^2}{gR} \quad \dots \quad (1)$$

When  $R = 1$  mile = 5280 feet,  $v$  = velocity = 60 miles per hour = 88 feet per second, and  $g = 32\frac{1}{2}$  feet, then

$$f = \frac{w \times 88^2}{32\frac{1}{2} \times 5280} = \frac{1}{12}w;$$

that is, the centrifugal force that urges the moving body to leave the curve, in this case, is  $\frac{1}{12}$  of its weight.

This force is slightly counteracted by the conical inclination of the tire of the wheels, each pair of which are firmly fixed on the axle that turns with them. This inclination of the tire, together with the lateral play of the flanges of  $\frac{1}{2}$  an inch on each side, and the centrifugal force impelling the carriages of the train, when moving in a curve, towards the exterior rail, enlarge the diameter of the exterior wheel, and diminish that of the interior, thus causing the train to roll on conical surfaces, which necessarily produces a centripetal force, the centre of which force is the vertex of the cone, of which the increased and diminished diameters of each pair of wheels are sections.

Let  $d$  be the outer diameter of the wheels,  $\delta$  the increment and consequently the decrement that the diameters of the exterior and interior wheels respectively receive, through the joint action of the centrifugal force and the inclination of the tire : then under these circumstances the respective diameters of the exterior and interior wheels will be

$$d + \delta \text{ and } d - \delta$$

also if  $R'$  be the radius of a circle which the centre of the carriage would describe in consequence of the inclination of the tire of the wheels, and  $b$  the breadth of the road or gauge : then  $R' + \frac{1}{2}b$  and  $R' - \frac{1}{2}b$  are the radii which would be respectively described by the exterior and interior wheels ; and by similar triangles

$$d + \delta : d - \delta :: R' + \frac{1}{2}b : R' - \frac{1}{2}b,$$

whence  $d : \delta :: 2R' : b$ , and

$$R = \frac{bd}{2}$$

Or, if  $\frac{1}{n}$  = inclination of the tire, and  $\Delta$  the deviation of the wheels, the increment or decrement  $\delta = \frac{2\Delta}{n}$ ; and, by substitution,

$$R = \frac{bdn}{4\Delta} \quad \dots \quad (2)$$

Also  $w$  and  $v$  representing the weight and velocity of the train, as in (1), and  $g$  the force of gravity, the centripetal force corresponding to the radius  $R'$  will be

$$f' = \frac{wv^2}{gR'} \quad \dots \quad (3)$$

Or, by substituting the value of  $R'$  from (2)

$$f' = \frac{wv^2}{g} \times \frac{4\Delta}{bdn} \quad \dots \quad (4)$$

Since the forces  $f$  and  $f'$  (1) and (3), act in contrary directions, they will hold each other in equilibrium when they become equal, and the train will cease to have a tendency to leave the curve; this takes place when

$$\frac{wv^2}{gR} = \frac{wv^2}{gR'}$$

or  $R = R'$

Also from (1) and (4)

$$\frac{wv^2}{gR} = \frac{wv}{g} \times \frac{4\Delta}{bdn}$$

whence

$$\Delta = \frac{bdn}{4R} \quad \dots \quad (5)$$

which is the deviation required to produce the equilibrium between the centripetal and centrifugal forces of the train. Therefore since  $R = R'$ , i.e., the vertex of the imaginary cone of which each pair of wheels are sections will coincide with the centre of the curve, there will in consequence be no dragging of either of the wheels on the rail.

In practice, however, it is safer to neglect the effect of the coning of the tires, and to calculate the superelevation of the rail as if the tires were cylindrical.

The rule for this is as follows :—

Let  $R$  = radius of curve in chains

$b$  = breadth of gauge of the line in feet; or more properly, the distance from centre to centre of rails.

$v$  = velocity of the train in miles per hour.

$x$  = superelevation to be given to the outside rail in inches.

Then

$$x = \frac{bv^2}{82.5 R}$$

For the narrow gauge, where  $b = 4$  ft. 11 in. = 4.91,

$$x = \frac{v^2}{17R} \text{ nearly.}$$

*Example.*—On a curve  $\frac{1}{2}$  mile (= 40 chains) radius it is expected that trains will travel at 40 miles an hour. What ought to be the superelevation of the outside rail?

$$x = \frac{40^2}{17 \times 40} = \frac{1600}{680} = 2.35 \text{ inches.} \quad \textit{Answer.}$$

**TABLES FOR REDUCTION OF DISTANCES AND CORRECTION OF LEVELS  
FOR CURVATURE, ETC.**

No. 1. Reduction for each Chain for the following Angles of Elevation.		No. 2. Difference between Apparent and True Level for distances in Chains. Correction in Decimals of Feet.				No. 3. Difference between Apparent and True Level for distances in Miles. Correction in Feet and Decimals.			
Angles.	Reduction in Links.	Distances in Chains.	For Curvature.	For Refraction.	For Curva- ture and Refraction.	Distances in Miles.	For Curvature.	For Refraction.	For Curva- ture and Refraction.
3° 0'	0.137	3	.0009	.0001	.0008	$\frac{1}{4}$	.042	.006	.036
3 30	0.187	3 $\frac{1}{2}$	.0013	.0002	.0011	$\frac{1}{2}$	.167	.024	.143
4 0	0.244	4	.0017	.0002	.0015	1	.375	.054	.321
4 30	0.308	4 $\frac{1}{2}$	.0021	.0003	.0018	1 $\frac{1}{4}$	.667	.095	.572
5 0	0.381	5	.0026	.0004	.0022	1 $\frac{1}{2}$	1.501	.215	1.286
5 30	0.460	5 $\frac{1}{2}$	.0031	.0004	.0027	2	2.668	.381	2.287
6 0	0.548	6	.0037	.0005	.0032	2 $\frac{1}{4}$	4.169	.596	3.573
6 30	0.643	6 $\frac{1}{2}$	.0044	.0006	.0038	3	6.003	.856	5.147
7 0	0.745	7	.0051	.0007	.0044	3 $\frac{1}{4}$	8.171	1.167	7.004
7 30	0.856	7 $\frac{1}{2}$	.0058	.0008	.0050	4	10.872	1.525	9.147
8 0	0.973	8	.0067	.0010	.0057	4 $\frac{1}{4}$	13.547	1.930	11.517
8 30	1.098	8 $\frac{1}{2}$	.0075	.0011	.0064	5	16.675	2.382	14.293
9 0	1.231	9	.0084	.0012	.0072	5 $\frac{1}{4}$	20.177	2.882	17.295
9 30	1.371	9 $\frac{1}{2}$	.0094	.0013	.0081	6	24.012	3.430	20.582
10 0	1.519	10	.0104	.0015	.0089	6 $\frac{1}{4}$	28.181	4.026	24.155
10 30	1.675	10 $\frac{1}{2}$	.0115	.0016	.0099	7	32.683	4.669	28.014
11 0	1.837	11	.0126	.0018	.0108	7 $\frac{1}{4}$	37.519	5.360	32.159
11 30	2.008	11 $\frac{1}{2}$	.0138	.0020	.0118	8	42.688	6.098	36.590
12 0	2.185	12	.0150	.0021	.0129	8 $\frac{1}{4}$	48.191	6.884	41.307
12 30	2.370	12 $\frac{1}{2}$	.0163	.0023	.0140	9	54.027	7.718	46.309
13 0	2.553	13	.0176	.0025	.0151	9 $\frac{1}{4}$	60.197	8.600	51.597
13 30	2.763	13 $\frac{1}{2}$	.0190	.0027	.0163	10	66.700	9.529	57.171
14 0	2.970	14	.0204	.0029	.0175	10 $\frac{1}{4}$	73.520	10.217	61.303
14 30	3.185	14 $\frac{1}{2}$	.0219	.0031	.0188	11	80.687	11.527	69.160
15 0	3.407	15	.0234	.0033	.0201	11 $\frac{1}{4}$	88.167	12.594	75.573
15 30	3.637	15 $\frac{1}{2}$	.0250	.0036	.0214	12	96.000	13.714	82.286
16 0	3.874	16	.0267	.0038	.0229	12 $\frac{1}{4}$	104.167	14.881	89.286
16 30	4.118	16 $\frac{1}{2}$	.0284	.0041	.0243	13	112.667	16.095	96.572
17 0	4.370	17	.0301	.0043	.0258	13 $\frac{1}{4}$	121.500	17.357	104.143
17 30	4.628	17 $\frac{1}{2}$	.0319	.0046	.0273	14	130.667	18.666	112.001
18 0	4.894	18	.0338	.0048	.0290	14 $\frac{1}{4}$	140.167	20.024	120.143
18 30	5.168	18 $\frac{1}{2}$	.0357	.0051	.0306	15	150.000	21.428	128.572
19 0	5.448	19	.0376	.0054	.0322	15 $\frac{1}{4}$	160.167	22.881	137.286
19 30	5.736	19 $\frac{1}{2}$	.0396	.0056	.0340	16	170.667	24.381	146.286
20 0	6.031	20	.0417	.0060	.0357	16 $\frac{1}{4}$	181.500	25.928	155.572
20 30	6.333	20 $\frac{1}{2}$	.0438	.0063	.0375	17	192.667	27.524	165.143
21 0	6.642	21	.0459	.0066	.0393	17 $\frac{1}{4}$	204.167	29.167	175.000
21 30	6.958	21 $\frac{1}{2}$	.0481	.0069	.0412	18	216.000	30.857	185.143
22 0	7.282	22	.0504	.0072	.0432	18 $\frac{1}{4}$	228.167	32.581	195.586
22 30	7.612	22 $\frac{1}{2}$	.0527	.0075	.0452	19	240.667	34.381	206.286
23 0	7.950	23	.0551	.0079	.0472	19 $\frac{1}{4}$	253.500	36.214	217.286
23 30	8.294	23 $\frac{1}{2}$	.0575	.0082	.0493	20	266.667	38.075	228.592
24 0	8.645	24	.0600	.0086	.0514	21	294.000	42.000	252.000
24 30	9.004	24 $\frac{1}{2}$	.0625	.0089	.0536	22	322.667	46.095	276.572
25 0	9.369	25	.0651	.0093	.0558	23	352.667	50.381	302.286
25 30	9.741	25 $\frac{1}{2}$	.0677	.0097	.0580	24	384.000	54.857	329.143
26 0	10.121	26	.0704	.0100	.0604	25	416.667	59.095	358.572
26 30	10.507	26 $\frac{1}{2}$	.0731	.0104	.0627	26	450.667	64.381	386.286
27 0	10.899	27	.0759	.0108	.0651	27	486.000	69.428	416.572
27 30	11.299	27 $\frac{1}{2}$	.0788	.0113	.0675	28	522.667	74.667	448.000
28 0	11.705	28	.0817	.0117	.0700	29	560.667	80.095	480.572
28 30	12.118	28 $\frac{1}{2}$	.0846	.0121	.0725	30	600.000	85.714	514.286
29 0	12.538	29	.0876	.0125	.0751				
29 30	12.964	29 $\frac{1}{2}$	.0906	.0129	.0777				
30 0	13.397	30	.0937	.0134	.0803				

TABLES OF OFFSETS FOR RAILWAY CURVES, ETC.

No. 4. Offsets or Ordinates at the end of the first Chain from tangent point of Railway Curves.								No. 5. Horizontal Distances to an Unit's Height to the following Angles of Elevation.	
Radius of Curve in Chains.	Offsets in Inches and Decimals.	Radius of Curve in Chains.	Offsets in Inches and Decimals.	Radius of Curve in Chains.	Offsets in Inches and Decimals.	Radius of Curve in Chains.	Offsets in Inches and Decimals.	Angle of Elevation.	Hor. Distance to one Perpendicular.
15	26·4000	65	6·0923	125	3·1680	225	1·7600	0° 5'	688
16	24·7500	66	6·0000	126	3·1428	230	1·7217	0 10	344
17	23·2941	67	5·9104	128	3·0937	235	1·6851	0 15	229
18	22·0000	68	5·8235	130	3·0461	240	1·6500	0 30	115
19	20·8421	69	5·7391	132	3·0000	245	1·6163	0 45	76
20	19·8000	70	5·6571	134	2·9552	250	1·5840	1 0	57
21	18·8571	71	5·5774	135	2·9333	255	1·5529	1 15	46
22	18·0000	72	5·5000	136	2·9117	260	1·5231	1 30	39
23	17·2174	73	5·4246	138	2·8645	265	1·4943	1 45	33
24	16·5000	74	5·3513	140	2·8285	270	1·4667	2 0	28
25	15·8400	75	5·2800	142	2·7887	275	1·4400	2 15	25
26	15·2307	76	5·2105	144	2·7500	280	1·4143	2 30	23
27	14·6666	77	5·1428	145	2·7310	285	1·3995	2 45	21
28	14·1428	78	5·0769	146	2·7123	290	1·3855	3 0	19
29	13·6551	79	5·0126	148	2·6756	295	1·3423	3 15	18
30	13·2000	80	4·9500	150	2·6400	300	1·3200	3 28	17
31	12·7742	81	4·8889	152	2·6052	305	1·2988	3 35	16
32	12·3750	82	4·8292	154	2·5714	310	1·2774	3 49	15
33	12·0000	83	4·7711	155	2·5548	315	1·2571	4 6	14
34	11·6470	84	4·7143	156	2·5384	320	1·2375	4 24	13
35	11·3142	85	4·6588	158	2·5063	325	1·2184	4 45	12
36	11·0000	86	4·6046	160	2·4750	330	1·2000	5 12	11
37	10·7026	87	4·5517	162	2·4444	335	1·1821	5 42	10
38	10·4210	88	4·5000	164	2·4146	340	1·1647	6 21	9
39	10·1538	89	4·4496	165	2·4000	345	1·1478	7 7	8
40	9·9000	90	4·4000	166	2·3855	350	1·1314	8 8	7
41	9·6588	91	4·3516	168	2·3571	355	1·1155	9 27	6
42	9·4285	92	4·3043	170	2·3294	360	1·1000	11 19	5
43	9·2093	93	4·2581	172	2·3023	365	1·0809	14 2	4
44	9·0000	94	4·2128	174	2·2758	370	1·0703	18 26	3
45	8·8000	95	4·1684	175	2·2628	375	1·0560	26 34	2
46	8·6087	96	4·1250	176	2·2500	380	1·0421	46 0	1
47	8·4255	97	4·0825	178	2·2248	385	1·0285		
48	8·2500	98	4·0408	180	2·2000	390	1·0154		
49	8·0816	99	4·0000	182	2·1758	395	1·0025		
50	7·9200	100	3·9600	184	2·1521	400	·9900		
51	7·7647	102	3·8824	185	2·1405	410	·9659		
52	7·6154	104	3·8077	186	2·1290	420	·9428		
53	7·4717	105	3·7714	188	2·1064	430	·9209		
54	7·3333	106	3·7358	190	2·0842	440	·9000		
55	7·2000	108	3·6667	192	2·0625	450	·8800		
56	7·0714	110	3·6000	194	2·0412	460	·8609		
57	6·9473	112	3·5352	195	2·0307	470	·8425		
58	6·8276	114	3·4736	196	2·0204	480	·8250		
59	6·7118	115	3·4435	198	2·0000	490	·8081		
60	6·6000	116	3·4138	200	1·9800	500	·7920		
61	6·4918	118	3·3559	205	1·9317	510	·7765		
62	6·3871	120	3·3000	210	1·8857	520	·7615		
63	6·2857	122	3·2459	215	1·8418	530	·7472		
64	6·1875	124	3·1935	220	1·8000	540	·7333		



# APPENDIX.

---

## ACTS OF PARLIAMENT

### FOR INCLOSING COMMONS AND WASTE LANDS.

BEFORE the year 1845 the inclosure of Commons and Waste Lands was effected by Special Acts of Parliament obtained for the purpose. The expense attending the passing of these Special Acts being very considerable, in the year 1801 a General Act was passed containing certain provisions usually inserted in the Special Acts, and from that date to the year 1845 the latter were founded on the Act of 1801, and contained the same provisions, either explicitly or by reference, with the exception of those required by the special circumstances of each case.

In the year 1845 the General Inclosure Act (8 & 9 Vict. c. 118) was passed.

This Act inaugurated an entirely new mode of procedure. Commissioners were appointed by it, to be styled the "Inclosure Commissioners for England and Wales." To these Commissioners applications on the part of persons proposing to inclose land subject to be inclosed under the Act may be made. On being thus set in motion, the Commissioners conduct the inclosure through its various stages in the mode prescribed by the Act of Parliament, local inquiries being instituted by an Assistant Commissioner, and the actual apportionment of the land, after the inclosure has been sanctioned by Parliament, being effected by a Valuer appointed by the persons interested, or, in default of agreement, by the Inclosure Commissioners.

The sanction of Parliament to inclosures is given in a bill or bills introduced annually and founded upon the reports of the Inclosure Commissioners. These bills contain nothing but a simple approval of the inclosures recommended by the Commissioners, a list of which is given in a schedule. All regulations for carrying out the inclosures are contained in the Act of 1845.

The General Inclosure Act 1845, the form of Report which the Inclosure Commissioners require from a Valuer, and a list of Amendment Acts passed subsequently to that of 1845, are appended for the information of readers.

It may be observed that, by the Metropolitan Commons Act 1866, all commons within the Metropolitan Police District are exempted from the operation of the Inclosure Act.



AN ABSTRACT of an ACT to facilitate the Inclosure and Improvement of Commons and Lands held in common, the Exchange of Lands, and the Division of intermixed Lands; to provide Remedies for defective or incomplete executions, and for the non-execution of the powers of General and Local Inclosure Acts, and to provide for the Revival of such powers in certain cases :—

(Preamble.) Whereby, after reciting, that it is expedient to facilitate the inclosure and improvement of commons and other lands now subject to rights of property which obstruct cultivation and the productive employment of labour, and to facilitate such exchanges of lands and such divisions of lands intermixed or divided into inconvenient parcels as may be beneficial to the respective owners, and that it is also expedient to provide remedies for the defective or incomplete execution and for the non-execution of powers created by general and local Acts of inclosure, and to authorise the revival of such powers in certain cases,—it is enacted as follows :—

1. One of Her Majesty's principal Secretaries of State may appoint two Commissioners, who, with the First Commissioner of Her Majesty's Woods, Forests, Land Revenues, Works, and Buildings,\* shall be the Commissioners for carrying the Act into execution.

2. The First Commissioner of Her Majesty's Woods, Forests, Land Revenues, Works, and Buildings, shall be chairman of the Commissioners. The Commissioners shall be styled "The Inclosure Commissioners of England and Wales," and shall have an office in London or Westminster, and shall have a common seal, and no order or award shall be of any force unless the same shall be sealed.

3. The Commissioners shall send to one of the principal Secretaries of State annual reports, and also when they think fit, special reports of their proceedings.

4. The Commissioners shall have power, with the consent of the Lord High Treasurer, or three or more of the Commissioners of Her Majesty's Treasury, to appoint Assistant Commissioners.

5, 6, and 7, relate to the appointment and fees of Commissioners and their servants.

8. Every Commissioner and Assistant Commissioner shall make a declaration before taking office.

9. All documents of the Tithe Commissioners or Assistant Commissioners shall be open to the use of the Inclosure Commissioners.

The Commissioner or Assistant Commissioner may summon witnesses, examine upon declaration, and call for documents.

The Commissioners may summon before a Valuer acting under the Act such witnesses as the Valuer shall certify to be necessary, and may cause documents to be produced before a Valuer, and every Valuer may administer or receive declarations, and examine upon declaration.

No person to be required under this section to travel more than ten miles from the place of his abode.

\* The Office of Woods, Forests, Land, and Revenues is now separated from the Office of Works, and different Crown rights are entrusted to them. By section 24 of the Act effecting this division (14 and 15 Vic., c. 42), it is enacted that the First Commissioner of Works and Public Buildings shall be the *ex officio* Inclosure Commissioner.

10. The Commissioners may delegate any of their powers to an Assistant Commissioner.

11. The lands subject to be inclosed under the Act are :—

- (1.) All land subject to any right of common.
- (2.) All gated and stinted pastures.
- (3.) All land held, occupied, or used in common for any time or purpose.
- (4.) All land in which the property or right of or to the herbage during the whole or any part of the year, or the property or right of or to the wood or underwood growing thereon, is separated from the property of the soil.
- (5.) All lot meadows.

12. Wastes of manors and lands subject to indefinite common rights at all times of the year shall not be inclosed without the previous authority of Parliament in each particular case.

13. No part of the New Forest, or the Forest of Dean, shall be subject to be inclosed.

14. No lands within the following distances of the places hereinafter named shall be inclosed without the previous authority of Parliament in each particular case, viz. :—

- (1.) 15 miles of the City of London.
- (2.) 2 miles of any city or town of 10,000 inhabitants.
- (3.) 2½ miles of " " 20,000 "
- (4.) 3 miles of " " 30,000 "
- (5.) 3½ miles of " " 70,000 "
- (6.) 4 miles of " " 100,000 "

15. No town or village green shall be inclosed.

16. The persons interested in land subject to be inclosed under this Act are, with certain exceptions in this section specified, the persons in the actual possession or enjoyment, or in the actual receipt of the rents and profits of such land, or of any common right thereon, or of any manor whereof such lands are waste.

17. Whenever Her Majesty shall be interested in land to be inclosed, she shall be represented by the First Commissioner of Her Majesty's Woods, Forests, Land Revenues, Works, and Buildings, or the Chancellor of the Duchy of Lancaster, as the case may be.

18. Whenever the Duke of Cornwall is similarly interested, he shall be represented by the Lord Warden of the Stannaries.

19. When several persons have a joint interest in land according to the provisions of the Act, they shall be entitled to one vote only in respect of their joint interest.

20. Whenever any person interested in land as aforesaid is under any legal disability, the guardian, trustee, committee of the estate, husband, or attorney respectively, or, in default, such person as may be nominated by the Commissioners, shall be substituted in his or her place.

21. Any person interested in land subject to the provisions of this Act may appoint an agent by power of attorney to represent him in the matter of the inclosure or other proceeding.

22. The proportionate value of the respective interests of the several persons interested in land to be inclosed shall be estimated as follows: (that is to say) where their interests shall be in respect of land, or other rateable property, then according to the proportional sums at which such property shall be rated to the relief of the poor; and where their interests shall be in respect of rights of

common, enjoyed or claimed in respect of any land, and not defined by numbers or stints, then according to the proportional sum at which the land in respect of which they enjoy or claim such rights of common shall be rated to the relief of the poor; and in case such interests shall be in respect of rights in a gated or stinted pasture, or of other rights defined by numbers or stints, then according to the proportional amount of their respective numbers or stints; but in case such interests shall be in respect of rights of common in gross not rated to the relief of the poor and not defined by numbers or stints, or in case from any other cause it shall appear to the Commissioners, or to the Assistant Commissioners, presiding at any meeting held for the purposes of this Act, impracticable to estimate such proportional value in manner aforesaid, it shall be lawful for the Commissioners to direct in what manner such proportional value shall be estimated, regard being had to the circumstances of each particular case; provided always that whenever the Assistant Commissioner shall have directed in what manner such proportional value shall be estimated under the power hereinbefore contained, he shall specially report to the Commissioners the circumstances under which it shall have become necessary to exercise such power, and the directions he shall have given in the exercise thereof.

23. The proportional value of the interest of the lord or lords of a manor shall be estimated in such manner as the Commissioners may direct.

24. The Commissioners shall print and circulate forms indicating the particulars of the information to be furnished to them by persons proposing to inclose land under the provisions of the Act.

25. Persons interested in land subject to be inclosed may make an application to the Commissioners, who shall, if they think the inclosure may be found to be expedient, appoint an Assistant Commissioner to inspect the land and hold meetings and hear any objections to the proposed inclosure, and any information or evidence which may be offered in relation thereto.

26. The Assistant Commissioner shall report the result of his inquiries to the Commissioners, and his opinion as to the proposed inclosure.

27. The Commissioners shall make all further inquiries they deem necessary, and embody the conditions of the proposed inclosure in a provisional order, and, if two-thirds of the parties interested consent to such provisional order, they shall certify the expediency of the inclosure to Parliament, or if the inclosure under this Act does not require the direction of Parliament, shall give notice on the church door and by advertisement of proceeding therewith.

28. Separate applications shall be made for distinct and separate tracts of land, and the consent of two-thirds of the persons interested in each tract must be obtained.

29. The lord of the manor shall be entitled, in right of his manor, to withhold his consent, upon which the inclosure shall not proceed.

30. The Commissioners may in any case of an inclosure of waste of a manor or lands subject to unstinted rights of common, require allotments for exercise and recreation, the size to be regulated by the population of the pariah, and if they do not require such allotments, they shall state their reasons for not so doing in their Annual General Report to Parliament.

31. The Commissioners may in any such case require allotments for the labouring poor, subject to a rent-charge payable to any person entitled to an allotment, and if they do not require such allotment, shall state why in their Annual General Report.

32. Inclosures certified to Parliament shall, when sanctioned, be carried out

according to the provisions of this Act, and the provisional orders made in the several cases.

Acts for the inclosure of lands shall be deemed public general Acts.

33. As soon as convenient after an Act is passed for the inclosure of land, or after thirty days from the Commissioners having given notice of proceeding with an inclosure, the Commissioners shall call, by twenty-one days' notice, a meeting of persons interested in the land to be inclosed, for the appointment of a Valuer, and shall, if they think fit, appoint an Assistant Commissioner to take the votes of the persons present. If the majority of interest and the majority in number do not agree, then the Commissioners shall appoint a Valuer; provided that no one shall be chosen who is interested in such inclosure, or the agent of an interested person.

34. The meeting appointed to choose the Valuer, or some other meeting called by the Commissioners, shall give the Valuer instructions as to the formation of roads, widening or improving existing public roads, the formation of places of recreation for the inhabitants of the neighbourhood, and allotments for the labouring poor, the formation of drains, and alterations and improvements on the inclosed land for the convenience of occupiers, and for other purposes; also for the raising and payment of expenses by the sale of part of the land, or by rate as the persons at the meeting shall think fit, and may make an agreement with the Valuer for his payment for the duties to be performed under the Act. The Commissioners may allow, disallow, alter, or add to such instructions as they shall think fit, and may, if necessary, frame fresh instructions not inconsistent with the provisional order and the Act, and may make an order for the payment of the Valuer. A copy of the instructions so settled, under the seal of the Commissioners, shall be handed to the Valuer with the provisional order and Act of Parliament, and the Valuer shall observe and obey the directions and declarations of such provisional order, Act, and instructions respectively.

35. The Valuer, upon determining any contested claim or objection, or upon awarding any costs, shall if he think proper, or the persons interested shall on their instructions to him so direct, be assisted by an Assistant Commissioner, who shall be a practising barrister-at-law of five years' standing at the least, and the determination of the said Valuer as to all such contested claims and objections and costs, shall be made pursuant to and in conformity with the decisions of such assessor; provided nevertheless that such assessor shall not interfere further in the execution of this Act than in settling what contested claims shall be allowed or disallowed, and what costs if any shall be allowed to, or paid by, any parties making or objecting to such claims.

36. If the Commissioners shall alter or add to the Valuer's instructions, the said instructions shall not be acted upon unless they are approved by the majority in number and the majority in respect of interests of the persons interested, at a meeting called for that purpose, with fourteen days' notice, by the Commissioners, and the inclosure shall not be proceeded with until some instructions to the Valuer, approved as last aforesaid, shall be finally allowed by the Commissioners.

37. A surveyor may be appointed at a meeting called by the Commissioners by the majority in number and in respect of interest, to assist or act under the Valuer.

38. No Valuer shall be capable of acting until he shall have made a declaration before the Commissioners, or some Assistant Commissioner, Justice of the Peace or Master-Extraordinary in Chancery, which shall be as follows:—

I do solemnly declare that I will faithfully, impartially, and honestly, according to the best of my skill and judgment, perform all the duties of a Valuer in the inclosure of according to the provisions of an Act passed in the year of the reign of Her Majesty Queen Victoria, entitled

Which declaration it shall be lawful for the Commissioners, or any Assistant Commissioner, Justice, or Master-Extraordinary in Chancery, to administer; and every such declaration so made and subscribed shall be countersigned by the person before whom the same shall have been made, and shall be sent by him to the office of the Commissioners, and a certificate under the seal of the Commissioners that the person named in such certificate has been appointed a Valuer in the matter of an inclosure, and has made and subscribed the declaration required by this Act, shall be conclusive evidence of such appointment and of his having made and subscribed such declaration.

39. If the Valuer shall represent to the Commissioners that the boundaries of any parish or manor in which the land proposed to be inclosed is situated, are not sufficiently distinguished, the Commissioners may set out the boundaries, and the boundaries so set out are hereby declared to be the boundaries of such parishes and manors respectively. And the Commissioners shall within one month publish the same, by delivering a description thereof in writing to one of the churchwardens or overseers of the poor of each of the parishes of which the boundary shall be so set out and to the lords or stewards of the manors of which the boundary shall be so set out, and by advertisement.

If any person or persons are dissatisfied with the determination of the Commissioners, a jury of twelve disinterested persons of the county shall decide the matter before an Assistant Commissioner, unless the Commissioners have received notice of the intention of the dissatisfied person to apply to the Queen's Bench to remove the determination into that court by certiorari. The Commissioners shall abide by the decision of the jury in every case where the matter is decided by one.

40. If any person summoned on the jury or to give evidence shall not appear or refuse to be sworn without reasonable excuse, they shall pay for every such offence a sum not exceeding £10. But witnesses should have a reasonable sum tendered to them for their costs and expenses.

41. Every jury and jurymen shall be subject to the same regulations and penalties as in any court at Westminster.

42. Provides for the costs of appeal to such jury.

43. The Commissioners shall take security for costs from persons appealing to jury.

44. Any person being dissatisfied with the determination of the Commissioners in respect to boundaries may appeal to the Court of Queen's Bench.

45. For the purpose of shortening or rendering straight any boundary fences between the land to be inclosed and any adjoining lands, it shall be lawful for the Valuer acting in the matter of any inclosure, with the consent in writing of the person interested in such adjoining lands, to set out and determine the boundaries between the land to be inclosed and such adjoining land, or to draw and define a new line of boundary as he shall judge proper for the purposes aforesaid; and after such boundaries shall have been so set out and determined as aforesaid, or such new line of boundary drawn and defined, the same shall be made, fenced, ditched, or mounded by such person in such manner and at such times as the Valuer shall direct, and shall for ever thereafter be deemed the boundaries and limits of such respective lands.

46. The Valuer may appoint meetings for the examination of claims, giving fourteen days' notice on the church door, and by advertisement, and may adjourn such meetings if he shall think fit.

47. All persons claiming any common or other right or interest in the land to be inclosed, shall deliver the same in writing to the Valuer at such meeting as he shall appoint for the purpose, stating particulars, and distinguishing the claims in respect of freehold, copyhold, customary and leasehold property from each other, and mentioning places of abode of claimants or their agents at which notice may be delivered.

48. A statement of all claims, in the matter of any inclosure which shall have been delivered to the Valuer acting in the matter of such inclosure as hereinbefore provided, shall be made and deposited by him at some public place within the parish in which the land to be inclosed, or the greater part thereof, shall be situate; and the Valuer shall give notice, on the church door of such parish, and by advertisement, of such statement having been deposited; and shall in such notice limit such time for the delivery of objections to claims as the Commissioners under the circumstances of each inclosure shall think reasonable, and by order under their seal direct, or in case no direction shall have been given by the Commissioners in this behalf, then such time as the Valuer shall think reasonable, not being less in any case than twenty-one days after such notice shall have been given, and every person who shall object to a claim shall deliver his objection in writing to the Valuer, and also deliver a copy of such objection at the place of abode of the claimant, or his agent, within the time limited for delivery of objections to claims as aforesaid; and no objection to any such claim shall be received by the Valuer after the time so limited for the delivery of objections to claims, unless for some special cause to be allowed by the Commissioners; and after the time limited for the delivery of claims shall have expired, the Valuer shall cause fourteen days' notice to be given of the time and place of the meeting for the examination of such claims, and for the attendance of all parties concerned therein; and at such meeting the Valuer shall proceed to examine into and determine such claims, and shall and may allow, or disallow, the same in whole or in part, and make such order therein as to him shall appear just; and in case any doubts or difficulties shall arise respecting such claims, or any differences shall happen between any of the claimants touching their respective claims, or the relative proportions of their rights and interests, the Valuer shall determine the same, and shall make such order therein as to him shall appear just, which order shall be final unless any party shall be dissatisfied with the determination of the Valuer, and shall give notice as hereinafter provided of his desire to have the claim or matter heard and determined by the Commissioners, or an Assistant Commissioner; or in case the Commissioners shall think fit to revise such determination under the power hereinafter contained; and in case the Valuer, on the determination of any claim which shall have been objected to as aforesaid, or of any objection which shall have been made to any claim, shall see cause to award any costs, it shall be lawful for the Valuer, upon application, to assess and award such costs as he shall think reasonable to be paid to the person in whose favour any determination shall have been made, and by the person whose claim or objection shall have been disallowed; and in case any person liable to pay such costs shall neglect or refuse to pay the same upon demand, or within fourteen days thereafter, the Valuer shall, by warrant under his hand and seal, directed to any person or persons whomsoever, cause such costs to be levied by distress; and if there shall be no goods or chattels whereon to levy such costs, it shall be lawful for the person in whose favour such costs

shall be awarded, to recover the same by action of debt, or on the case in which action it shall be sufficient for the plaintiff to declare that the defendant is indebted to him in the sum specified in the order of adjudication made by the Valuer, and in consequence of such order, without setting forth any other proceedings under this Act, provided always that the Valuer may pay the expenses of any witnesses, or of the production of any writings, maps, plans, and surveys, or copies thereof, where such witnesses shall attend, or such maps, plans, surveys, or copies thereof shall be produced before such Valuer, only on the request and for the information or guidance of the Valuer (and not on behalf of any party in difference), such last-mentioned expenses to be considered as part of the expenses of the inclosure.

No such claim shall be received after the last meeting to be held for that purpose, except for some special cause allowed by the Commissioners.

49. Neither Valuer, Commissioner, or Assistant Commissioner shall have power to determine the title of any lands, or determine any right between parties contrary to the actual possession, but if they are of opinion against the rights of the party in possession, shall forbear to make any determination thereupon until possession has been recovered, or they may specify the rights in dispute, without naming the person entitled to them.

50. All encroachments and illegal inclosures made upon the land to be inclosed within twenty years before the first meeting for the examination of claims in the matter of the inclosure shall be deemed part of the land subject to be inclosed. An interest in the land to be inclosed may, however, be allowed to the persons in possession of such encroachments, and they may take down and convert to their own use all erections on the land so encroached.

51. Any land used for charitable or parochial purposes shall not be deemed part of the land to be inclosed without compensation being given to the persons in possession, or the trustees of such lands.

52. Any land which has been inclosed for more than twenty years shall be deemed an ancient inclosure, but shall not carry any right of common.

53. Any one proving ancient tofts, foundations, or sites of ancient commonable messuages, or cottages, shall be entitled to the same compensation as if such messuages or cottages were standing thereon.

54. If any of the rights claimed are not sustainable in law, the claim may be allowed if there has been sixty years' enjoyment.

55. After the Valuer shall have heard all claims and objections, he shall publish a schedule thereof, and of his determinations thereon, and deposit the same for thirty days in some public place, and give notice on the church door and by advertisement of such deposit, so that the claims of any dissatisfied persons may be reheard by the Commissioners.

56. Any person dissatisfied with the Commissioners' determination may have a trial at law on a feigned issue at the next assizes.

57. If no notice of dissatisfaction be given, or the notice not acted upon, or the trial at law not proceeded with, the Commissioners' determination is conclusive.

58. If any person, plaintiff, or defendant, should die while any action is pending, the action shall not abate, and an action may be commenced against a deceased person in favour of whom, when alive, the Commissioners have determined.

59. When the Commissioners award costs, they may assess them and issue distress warrant to recover them.

60. The parties to an action upon a feigned issue may refer the matter to an arbitrator, and the costs of the arbitration shall abide the event. The Commissioners may require security for the payment of the costs of arbitration.

61. The Valuer acting in the matter of any inclosure may set out and make such common ponds, ditches, water-courses, embankments, tunnels, and bridges, of such extent and form, and in such situations, as he shall deem necessary, and as shall not be inconsistent with the terms and conditions and instructions herein-before mentioned in the land to be inclosed; and also to enlarge, cleanse, or alter the course of, and improve any of the existing ditches or water-courses, embankments, tunnels, or bridges, as well in and over the same land, as also in any ancient inclosures, or other lands in the parish, or respective parishes, in which the land to be inclosed may be situate as the Valuer shall deem necessary, making such satisfaction to the proprietors of such ancient inclosures or lands, for the damage done thereby, as the Valuer shall think just; and the expense of making and enlarging, altering and cleansing, such ponds, ditches, water-courses, embankments, tunnels, and bridges, when the same shall be first done in pursuance of this Act, if not otherwise provided for, shall be raised and paid in the same manner as the other expenses of the inclosure; but all such ponds, ditches, water-courses, embankments, tunnels, and bridges, shall at all times afterwards be repaired, cleansed, and maintained by such persons, and in such manner, as the Valuer shall direct; provided that no water-course be diverted or turned without the consent in writing of the person interested in the land from which the same may be diverted, and of the person interested in the lands into which the same may be turned, or to the prejudice of any person interested in such water-course, except with his consent in writing, and that no ditch or water-course, embankment, tunnel, or bridge, be enlarged or altered on any land, other than the land to be enclosured, without the consent in writing of the person interested in such land.

62. In the first place, the Valuer acting in the matter of any inclosure, shall and may, before he shall proceed to make any of the divisions and allotments of the land to be inclosed, in pursuance of, or in manner not inconsistent with, the instructions given to such Valuer as aforesaid, set out and make public roads and ways, and widen public roads and ways, in or over the land to be inclosed, and stop up, divert, or alter, any of the roads or ways passing through the land to be inclosed, or through any old enclosures in the parish, or respective parishes, in which the land to be inclosed shall be situate, and the soil of such of the roads and ways so to be discontinued and stopped up as pass through the lands to be inclosed, shall be deemed part of the lands to be inclosed; provided always that nothing herein contained shall authorise the altering or diverting any turnpike road, unless the consent of the majority of the trustees of such turnpike road, assembled at a public meeting called for that purpose, be first obtained; provided also, that before any public road or way shall be discontinued, diverted, stopped up, or altered by the Valuer acting in the matter of any inclosure, the Valuer shall cause to be affixed at each end of such road or way a notice to the effect that the same is intended to be discontinued, stopped up, diverted, or altered, as the case may be, from and after a day to be mentioned in such notice, and the Valuer shall also cause the same notice to be given by advertisement for four successive weeks, and also on the church door on the four Sundays of the said four successive weeks, and after the said several notices shall have been so given, such road or way shall, from and after the day in such notice mentioned, be deemed to be discontinued, stopped up, diverted, or



altered, as the case may be, subject, however, to such appeal as is hereinafter mentioned.

63. Any person after the alteration of any road may appeal to the Quarter Sessions.

64. Provides for the trial of such appeal.

65. Such public carriage roads so to be set out as aforesaid, shall be well and sufficiently fenced on both sides by such of the persons interested in the land to be inclosed, and within such time as the Valuer shall direct, and the Valuer shall form and complete such parts of the said public roads and ways as shall be newly made, and every such public road and way to be set out and made under this Act shall be of the width required by the Act of the 6th year of King William the Fourth, intituled "An Act to Consolidate and Amend the Laws relating to Highways in that part of Great Britain called England," for a road or way of the like description which may be dedicated to the use of the public.

66. The expenses of making and altering roads shall be paid as the expenses of the inclosure shall be directed to be paid.

67. Roads to be repaired by the parish after certificate by two Justices of the Peace.

68. The Valuer shall and may set out such private or occupation roads and ways through the lands to be inclosed as he shall think requisite for the use of the persons interested in such lands, or any of them; and any expenses which the Valuer may incur relative to the setting out or formation or completion of such private roads and ways, or any of them, shall, unless the Valuer shall otherwise direct, be paid in the same manner as the other expenses of the inclosure; and such expenses of the formation and completion of such private roads and ways as the Valuer shall direct shall be borne by, and after the formation and completion of such private roads and ways, the same shall be maintained and kept in repair by and at the expense of the owners and proprietors for the time being of the land inclosed, or such of them, and in such shares and proportions, and in such manner, as the Valuer shall direct; and after such private roads and ways shall have been set out and made, the grass and herbage arising thereon shall for ever belong to and be for the use of such persons interested in the lands to be inclosed as the Valuer shall direct, and in the absence of such direction, shall belong to the proprietors of the land to be inclosed which shall next adjoin the said roads and ways on either side thereof as far as the crown of the road; and after such setting out as aforesaid, all private or occupation roads or ways over, through, and upon the lands to be inclosed, which shall not be set out as aforesaid, shall be for ever stopped up and extinguished.

69. The Valuer, before the making of the award, when the Commissioners shall think necessary for the purpose of the inclosure, and, by order under their seal, authorise or direct by notice on the church door, may order all or any part of the rights of sheepwalk, common, or other rights in or over the land to be inclosed, or any part thereof, to be extinguished from such time, or the exercise thereof to be suspended during such time, as shall be expressed in such notice; and from the time mentioned in such notice such rights shall be extinguished or suspended accordingly; and if during the suspension or after the extinguishment of any such rights of sheepwalk, common, or other rights as aforesaid, any person shall permit his horses, cattle, sheep, or swine to go or depasture upon any of the lands over which such rights shall be suspended or extinguished, it shall be lawful for the Valuer acting in the matter of the inclosure, or any other person by his order (testified in writing under his hand), or any of the persons interested in such lands or in the inclosure thereof, to distrain such horses, cattle, sheep, or swine, being upon such

lands contrary to such order, and to impound the same until the person so offending shall pay to the person so distraining such sum of money as the Valuer shall, by writing under his hand, have previously ordered, not exceeding ten shillings for each horse or head of cattle, and five shillings for each sheep or swine so distrained, and in case the same shall not be paid within seven days after the same shall have been impounded, the Valuer is hereby authorised to recover the same by way of penalty as hereinafter mentioned.

70. The Valuer may at such time as he shall think fit, by notice on the church door, direct the course of husbandry and the stint or rule of stocking that shall be observed upon the land to be enclosed until the time when the enclosure thereof shall be completed, as well with respect to the laying down, ploughing, sowing, fallowing, manuring, and tilling thereof, as to the stocking and feeding of the commonable lands and fallows or stubbles upon the same, and to direct such recompense to be made as he shall think right to any person injured by such directions, all which directions shall be binding upon all parties interested, their farmers and tenants, and the Valuer shall impose such pecuniary penalties on every person not conforming to such directions as he shall think necessary, not exceeding the sum of 5*l.* per acre in the case of cross-cropping, or withholding from the land its due proportion of manure, or 10*l.* in any other case, for any one offence, and shall also determine in all cases where the tenant is entitled by agreement or custom to the manure arising from the lands in his occupation, by whom and in what sum of money such tenant shall be compensated for any such manure left or given up by him, and such penalties and other sums of money shall be recovered in the same manner as by this Act directed for the recovery of penalties.

71. The Valuer shall by writing under his hand order what recompense in money shall be made to the owner of any crops, growing according to his agreement or lease, or according to the customary mode of cultivation within the parish in which the land to be enclosed shall be situate upon such land at the time of the division, allotment, and enclosure for the said crops by the person to whom the land on which such crops are growing shall be allotted, and also what recompense in money shall be paid, and by whom, to any tenant or occupier of land, as well for the ploughing, tilling, cultivating, manuring or folding any land to be enclosed for the benefit accruing thereby to the person to whom such land shall be allotted, or for any loss or disadvantage which any tenant or occupier may sustain by the loss of his following or way-going crops upon the land to be enclosed, and if in any of the said cases, the money to be paid for such recompense be not paid at the time and in the manner ordered by the Valuer, then the same may be recovered by the person entitled thereto from the person liable to pay the same in the same manner as penalties and forfeitures are recoverable under this Act.

72. The Valuer shall allot to the surveyor of highways for the time being of the parish in which the land proposed to be enclosed, or any part thereof, shall be situate, and to his successors for ever, such part of the land proposed to be enclosed as by the instructions given to such Valuer, shall have been directed to be appropriated for supplying stone, gravel, or other materials for the repairs of roads and ways, as aforesaid; or in case no such instructions shall have been given in this behalf, and the Valuer shall think an allotment necessary for the purposes aforesaid, such part as the Valuer shall think fit, and such allotments shall be enclosed and fenced as the Valuer shall direct, and shall from the confirmation of the award be vested in the surveyor of the highways within the said parish for the time being, in trust for the purposes aforesaid, and the grass and herbage of such allotments shall belong to such persons as by the Valuer shall be directed,

and if he shall make no such direction, then such surveyor shall from time to time let any such allotment, reserving the right to get and take away such stone, gravel, and other materials, when and as he shall think fit for the most money that can be obtained for the same, and shall apply the rents and profits towards the repairs of the public roads or highways within the said parish, and the said surveyor shall account for such rents and profits in the same manner as he is by law accountable for other monies that shall come to his hands in the capacity of surveyor of the highways, and shall be subject to the like penalties for the neglect thereof.

73. The Valuer shall, and may, in pursuance of the directions of, or in any manner not inconsistent with, the directions of the provisional order of the Commissioners, or any act hereafter to be passed, or the instructions given to such Valuer as aforesaid, set out and allot such part of the lands to be enclosed as by such provisional order or act or instructions respectively shall have been directed to be appropriated as a place of exercise and recreation for the inhabitants of the said parish and neighbourhood, and such allotment shall, unless the same shall be otherwise awarded under the provision hereinafter contained, be made and awarded to the churchwardens and overseers for the time being of the parish in which the same shall be situated, and shall be held by the churchwardens and overseers for the time being of the said parish for the purposes aforesaid, and shall be in the first instance fenced, and, where occasion shall require, drained and levelled by the Valuer, the expense in such case to be considered part of the expenses of the enclosure, or shall be fenced by any person to whom adjoining land shall be allotted, as the Valuer may direct, and the fences of such allotment shall for ever afterwards be repaired and maintained, and the surface thereof kept drained and level by the churchwardens and overseers, or by the churchwardens and overseers of the several parishes interested therein, in such proportions and manner as shall be directed by the Valuer, out of the rents to be received for the herbage of the said allotment or out of the poor rate of the said parish, or respective parishes, or otherwise, and the grass and herbage growing upon such allotment may be from time to time let by the churchwardens and overseers, in whom the same shall be vested, and the rents which shall be received by them for the same shall be by them from time to time applied in the first place in maintaining and repairing the fences of the said allotment and keeping the surface thereof drained and level as aforesaid, and subject thereto, in aid of the rates for the repair of the public highways in the said parish or respective parishes, and the Valuer shall in like manner set out and allot such part of the land to be enclosed as by such provisional order, or act, or instructions, as aforesaid, shall have been directed to be appropriated as an allotment for the labouring poor, unto the churchwardens and overseers of the poor of the parish in which such allotment shall be situate, subject nevertheless to a rent charge, to be payable thereout, to any person or persons who may be entitled to allotments under such inclosure as hereinafter provided, and the said Valuer shall, in like manner, in pursuance of the directions of, or in any manner not inconsistent with the directions of such provisional order, or act, or instructions, as aforesaid, set out and allot for the other public purposes mentioned in such provisional order, or act, or instructions, as aforesaid, such parts of the land to be enclosed as shall have been thereby respectively directed to be set apart for such purposes, and such allotments shall be made to such persons respectively, with such regulations and provisions as to the fencing, maintenance, use, and enjoyment thereof respectively, as the Valuer, with the approbation of the Commissioners, shall direct ;

and in every case in which the Valuer, with such approbation of the Commissioners, shall not think it necessary or proper to direct the same to be otherwise made, such allotments shall be made to the churchwardens and overseers of the poor for the time being of the parish in which such allotment is situate, and all allotments which shall be made to the churchwardens and overseers under this act, shall be held by the churchwardens and overseers of the poor for the time being, in the same manner, and with the same legal powers and incidents, as if the same allotments were lands belonging to the parish, but in trust nevertheless for the purposes for which the same shall be allotted and subject, as to the said allotment for the labouring poor, to the provisions in relation thereto hereinafter contained, and as to all other such allotments subject to such directions for the maintenance, fencing, management, and use thereof, as the Valuer, with the approbation of the Commissioners, may think fit.

74. Provided always, That the Valuer may, with the approbation of the Commissioners, set out and allot such land as shall be appropriated as a place of exercise and recreation as aforesaid to any person entitled to an allotment under the enclosure, and who shall consent to receive the same in full or in part of his allotment, and the person to whom the land so to be appropriated shall be allotted, and all future owners thereof, shall, unless it shall be otherwise directed by the award, be subject to the obligation of maintaining the fences of such land, and of preserving the surface thereof in good condition, and of permitting such land to be at all times used for exercise and recreation by the inhabitants of the parish and neighbourhood, and subject to such obligations, the herbage of such land shall belong to the person to whom such land shall be so allotted.

75. Allotments for the labouring poor may be made subject to a corn-rent charge, to vary and be recoverable as a tithe-rent charge.

76. After the several allotments hereinbefore directed shall have been set out and made, and after making provision for payment of the expenses by sale of land, in case the expenses shall be so directed to be paid, the Valuer shall allot and award unto the lord of the manor so much and such part of the land proposed to be enclosed as shall in the judgment of the Valuer be equal (quantity and value considered) to such a part of the residue of such land as shall be proportioned to his right or interest therein, according to the directions of the provisional order of the Commissioners, in lieu of his right and interest in the soil of the said land, exclusive of any other allotments which may be made to such lord in lieu of or in satisfaction for any other rights or interests in such land to which he may be entitled, and which shall not have been included in the estimate in such provisional order of his right and interest, and in case it shall have been declared by such provisional order that the right or interest of the lord has been estimated exclusively of his right or interest in all or any of the mines, minerals, stone, and other substrata under the land to be enclosed, then the Valuer shall and may, on the request in writing of the lord, reserve or award to the lord such rights and easements for searching, for working, and carrying away such mines, minerals, stone or other substrata, which shall not have been included in such estimate of his right and interest, subject to such provisions for compensation for damage to be done to the surface in the exercise of such rights and easements as, by the Valuer, with the approbation of the Commissioners, shall be thought reasonable, and as shall not be inconsistent as to the terms of such provisional order.

77. After the several allotments hereinbefore directed shall have been set out and made, and after making provision for all or any part of the expenses of the enclosure by sale of lands, in case all or any part of the expenses shall be so

directed to be paid, the Valuer shall divide, allot, and award all the remainder of the land to be inclosed unto and amongst the several persons who shall be interested therein, in such shares and proportions as he shall adjudge and determine to be proportionate to the value of their respective rights and interests, which shall have been claimed and allowed under the provisions hereinbefore contained.

78. Where any allotments shall be made for the labouring poor, under the provisions hereinbefore contained, subject to any rent-charge or rent-charges, such rent-charge or rent-charges may be allotted to any person or persons who may elect to receive the same in full or in part of his or their allotment or allotments; and in case no person shall so elect to receive the same, then to such persons, and in such shares, as the Valuer may think convenient for the purpose of equalising allotments or otherwise; and it shall be lawful for the Valuer, for the purposes of allotment under this clause, to estimate the value in fee-simple of every such rent-charge to be four-fifths only of the value of an allotment of land equal in net annual value to such rent-charge.

79. Separate allotments are to be made by the Valuer to the same person in respect of separate titles.

80. In case any number of persons may wish to have their allotments thrown together, and only distinguished by metes or bounds, the Valuer may set out such allotment in one parcel of land with an outer or ring fence only.

81. It shall not be lawful for the said Valuer to allot to any other person than the proprietor thereof any land (other than encroachments and enclosures not authorised by law, made within twenty years next before the first meeting for the examination of claims as aforesaid), which may be cultivated as orchard or garden, or on which any building may have been erected, or which may have been enclosed by virtue of any agreement between the proprietor thereof and the persons having right of common over the same without the consent in writing of such proprietor.

82. The Valuer, in making the several allotments hereby directed, shall have due regard as well to the situation of the respective houses or homesteads of the persons interested in the land to be enclosed, as to the quantity and quality of the land to be allotted to them respectively, so far as may be consistent with the general convenience of such persons, and that such Valuer, in making the said allotments, shall have particular regard to the convenience of the persons interested, in respect of the smallest estates, in the land subject to be enclosed under this Act.

83. The several allotments to be made, except the allotments to the surveyor and churchwardens and overseers respectively, and the other allotments for public purposes, shall be enclosed, ditched, and fenced at the expense of the respective persons to whom the same shall be allotted, in such manner and within such times as the Valuer shall direct; and the fences so to be made shall for ever afterwards be repaired and maintained by such persons as the Valuer shall direct, and if from the situation, or from any other circumstance, it shall happen that any person to whom any allotment shall be made, shall not have a fair proportion of the boundary ditches or fences assigned to him to make, it shall be lawful for the Valuer acting in the matter of any enclosure, to ascertain and appoint what sum of money shall be contributed by such person towards making the boundary ditches and fences of the allotments of such other persons as shall have assigned to them to make too great a proportion thereof, and such money shall be paid to such persons, and in such manner, as by the Valuer shall be

directed, and the same may be recovered in the same manner as penalties or forfeitures are recoverable under this Act.

84. If any person's interest in the land to be enclosed is sold before the allotment is made, the Valuer shall, upon notice from the vendor, make the allotment to the purchaser.

85. If any person may die before the enclosure shall be completed, the Valuer may make the allotments to his legal representatives, and the enclosure shall not be interfered with.

86. The valuer, with the consent in writing of the person interested in any old inclosed land, or other land not subject to be enclosed, may direct the aforesaid land to be considered as allotable land to be enclosed, allowances being made to the interested person on account of the situation or other beneficial circumstances thereof, and the Valuer shall allot to the person interested in such old enclosed lands, so much of the land to be inclosed as he shall think reasonable and just.

87. Where the freemen or burgesses of any city or borough, or the householders or inhabitant householders of any town or place, or any class or description of such freemen, burgesses, householders, or inhabitant householders, or any other persons as a class, shall be entitled to rights of common, or other rights over the lands to be enclosed, it shall be lawful for the Valuer to award, in respect of such rights, one or more allotment or allotments, for the benefit of the class so entitled, to any two or more trustees, who shall be nominated by the majority at such meeting, as hereinafter mentioned, or in case two or more trustees shall not be nominated at such meeting, then to such trustees as the Commissioners shall approve, with provisions for the appointment of new trustees from time to time, or to the churchwardens and overseers of the poor of the parish in which each allotment shall be situate, in trust for the parties entitled to the right in respect of which the allotment shall be made; and it shall be lawful also for the Valuer, having regard to such instructions, if any, as may have been resolved on at such meeting as hereafter mentioned, or to such instructions as shall be given by the Commissioners in this behalf, to direct in what manner, and under what regulations, such allotment shall be occupied or enjoyed by the persons from time to time entitled to the benefit thereof, and (in case the Valuer, having regard to such instructions, shall think fit) to give directions and powers for the letting of such allotment from year to year, or for any term of years, subject to such provisions and restrictions as the said Valuer, with the approbation of the Commissioners, shall think fit, and for the receipt of the money to arise from such letting, and for the application of such money for the benefit of the persons entitled to the benefit of the allotment, and to give all such directions and provisions for the fencing, draining, and management of such allotment as the Valuer may think expedient.

88. Provided also, That the valuer, with the approbation of the Commissioners and of such meeting as hereinafter mentioned, may sell the whole or any part of any allotment to which any such class of persons as aforesaid shall be entitled under this act; and the allotment, or any part thereof, so sold, shall be conveyed by the Commissioners as the purchasers shall direct, and the Commissioners shall sign a receipt for the purchase-money, which shall be a sufficient discharge for the same; and the purchase-money arising from the sale, or the surplus thereof, after payment thereof of any expenses to which the same shall be liable, shall, with the approbation of the Commissioners, be paid to any trustee or trustees, upon trust for the investment thereof, with provisions for the appointment of new trustees from time to time, and for the application of the interest and annual produce of such investment to such purposes, for the benefit of the persons who

would have been entitled to such allotment, or the part thereof so sold, in case the same had not been sold, as the Commissioners shall approve, and by final award in the matter of such enclosure direct.

89. When the claim of any class of persons entitled as aforesaid shall be allowed, the Valuer shall certify such allowance to the Commissioners, and the Commissioners shall call a meeting of such persons by advertisement, for the purpose of appointing trustees of the allotment to be made for their benefit, and for giving instructions to the Valuer concerning the enjoyment, occupation, and management of such allotment, or for letting the same, and for the application of the money to arise from such letting, or in case the meeting shall think fit that such allotment, or any part thereof, shall be sold for directing the sale thereof, and the investment of the money arising from such sale, and the application of the income thereof; and the Commissioners, having reference to the total number of such class (so far as the Valuer or the Commissioners may have ascertained the same), shall by such notice declare the number of persons who should be present at such meeting to give validity to the proceedings, and the decision of the majority at such meeting shall bind the minority and all absent parties: Provided always, that no meeting shall be effectual for the purpose aforesaid, unless such a number of the said persons shall attend the same as shall be mentioned in that behalf in the advertisement calling such meeting; and if no effectual meeting shall be held for the purpose aforesaid, or, being held, no instructions shall be resolved on by the majority present at such meeting, or in case the Commissioners shall deem such instructions unjust and unreasonable, the Commissioners may give such instructions to the Valuer, in respect of the matters aforesaid, as they shall think fit, provided that no sale of any such allotment, or any part thereof, shall be made, except in pursuance of a resolution of a meeting called as aforesaid; but a recital in the conveyance by the Commissioners, upon any sale, that such sale was duly authorised, shall, for all purposes of title, be evidence that such sale was made in pursuance of the resolution of a meeting duly called as aforesaid.

90. When an allotment is made to a number of persons interested in undivided shares, the Valuer may make partition thereof.

91. The costs of the partition shall be borne by proprietors jointly interested in the estates parted.

92. It shall be lawful for the Valuer to allot and award any land to be enclosed in exchange for any other land within the parish in which the land to be enclosed shall be situate, or any adjoining parish; and it shall be lawful for the Valuer, in exercise of this present power, to allot all or any part of the land which would have been subject to be allotted under this Act, for the purposes of exercise and recreation, or for the labouring poor, or for any other public purposes, to any person in exchange for other land in the parish, or in any adjoining parish, which shall appear to the Valuer more suitable or convenient for the purposes of exercise and recreation, or for the labouring poor, or for such other public purposes as aforesaid, and to allot such other land for such purposes accordingly: and all lands taken and allotted as aforesaid under this provision, although not situate in the parish in which the land given in exchange for the same shall be situate, shall, for the purposes of the provisions herein contained, be deemed to be within such parish, and be managed and dealt with accordingly: Provided that all exchanges under which land shall be taken and allotted for public purposes as aforesaid, shall be made with the consent of the person interested in the land so taken, and that all other exchanges be made with the consent in writing of the persons interested in the lands so exchanged; and every such exchange so to be made shall

be valid and effectual to all purposes, and shall be specified and declared in the award : Provided also, That no exchange shall be made of any land held in right of any church or chapel, or other ecclesiastical benefice, without the consent, testified in writing, of the bishop of the diocese, and the patron of such benefice : Provided also, That all costs and expenses attending the making and completing of any such exchanges, except exchanges of land taken for public purposes, shall be borne by the several parties making such exchanges, in such manner and in such proportions as the Valuer shall direct, and in case of non-payment thereof, shall be recovered in the manner directed, with respect to the recovery of penalties and forfeitures ; and the expenses of the exchanges of land taken for public purposes shall be considered part of the expenses of the enclosure.

93. No wills or settlements are to be affected by this Act.

94. All land taken in exchange, or on partition, or allotted under this Act, shall be held under the same tenures, rents, customs, and services, as the land in respect of which such land shall have been given in exchange, or on partition, or allotted.

95. Immediately after the allotments herein directed to be made on any enclosure shall have been marked and staked out, the Valuer acting in the matter of such enclosure, may direct the same to be entered upon by the persons respectively for whom the same shall be intended ; and immediately after the Valuer shall so direct them to be entered upon, all leases, agreements, and tenancies at rack-rent subsisting of any part of the land to be enclosed, or which shall be exchanged in pursuance of this Act, or any common right thereon, shall be exchanged in pursuance of this Act, or any common right thereon, shall, so far only as respects the land to be divided and allotted or exchanged, or common right, cease and be void at such time or times as the Valuer shall, by writing under his hand, direct or appoint, so as the respective lessors or landlords of such land do, before or at the respective times at which such leases, agreements, or tenancies shall be directed to cease, make and pay such satisfaction to the respective lessees or tenants, for the loss which shall be sustained by the determination of such leases, agreements, and tenancies respectively, so far as regards the land or common right, the leases, agreements, and tenancies whereof are hereby authorised to be determined, as shall be mutually settled and agreed between them, or as the Valuer, being required by either of the parties, shall ascertain and direct ; and the Valuer, being so required, is hereby empowered and directed, by writing under his hand, to apportion a reasonable and proportionable part, having regard to the season of the year, of the rent reserved on any such lease, agreement, or tenancy, for or in respect of the time which shall have elapsed between the last day on which any payment of the rent shall have become due, and the determination of any such lease, agreement, or tenancy, and such part of the rent shall be recoverable by such ways and means as may by law be used for the recovery of rent in arrear ; and the Valuer is hereby empowered and directed, in every case where such land or common right shall be held, by virtue of any such lease, agreement, or tenancy, together with other lands or hereditaments, by one entire rent, by writing under his hand, to apportion and determine what part of rent shall be deducted, in respect of the land or common right in such lease, agreement, or tenancy, comprised as to which the same shall be determined as aforesaid, and from what time such deduction shall take place, and the rest of the rent reserved on any such lease, agreement, or tenancy, shall, during the remainder of the term thereof, be the rent of and for the residue of such lands and hereditaments, and shall be payable and recoverable in like manner as the entire rent reserved by such lease, agreement, or tenancy shall immediately before such apportionment be payable and recoverable, and the lessor or



reversioner shall, in respect of such apportioned rent, and in respect of the residue of such lands and hereditaments, have the benefit and advantage of the provisions and conditions which would have been applicable to the entire rent, and to all the lands and hereditaments comprised in such lease, agreement, or tenancy, in case such lease, agreement, or tenancy had not been determined as to any part of such land : Provided always, That no lease, agreement, or tenancy shall be determined as aforesaid, as to any house, cottage, or other building, without three calendar months' previous notice in writing of such determination, under the hand of the Valuer, shall have been given to the lessee or tenant, or left at such house, cottage, or building.

96. No seigniories, royalties, franchises, and manorial jurisdictions shall be affected by this Act, except with the consent of the owners.

97. Minerals under regulated pastures may be reserved to the lord of manor, while minerals under lands to be held in severalty are relinquished.

98. All right to minerals under the land inclosed existing distinct from the property in the surface, and not compensated upon an enclosure, shall not be affected by the enclosure.

99. All trees and underwood shall go with the land whereon they respectively stand, the persons taking such lands paying for the same to the owners thereof ; if payment not made, then owners of trees may enter and take them.

100. No cattle shall be allowed to pasture on the roads which the Valuer shall order to be set out, but proprietors of adjoining lands may depasture the cattle on their own frontage.

101. The Valuer may at any time before the confirmation of the award make alterations in the allotments and in the roads he has laid out, with the approbation or by the direction of the Commissioners. If any persons shall be injured by these alterations, recompense shall be made to them.

102. The Valuer shall, as soon as conveniently may be after the division and allotment of the land to be enclosed shall be completed, draw up a report\* in writing, with a map thereunto annexed, which shall specify all claims allowed, and all the allotments, exchanges, and petitions made in the matter of such enclosure, and all roads, ways, and works set out or directed to be made by the said Valuer ; and such report shall contain all such other directions and determinations authorised by this Act as the said Valuer shall think proper for the purposes of the enclosure ; and the map to be annexed to such report shall comprise and show the land to be enclosed, and the lands exchanged, and also the lands in respect of which any allotment of the land enclosed shall have been made, and shall distinguish by proper references the allotments made in respect of the several lands respectively, and such other particulars as the Commissioners shall, by any general or special instructions, in relation to such report direct the Valuer to set forth therein ; and such report shall be signed by the Valuer, and shall, together with the map thereunto annexed, be sent to the office of the Commissioners.

103. A copy of the said report shall be deposited by the Commissioners in some public place in the parish for the inspection of persons interested in the land, and meetings shall be held to hear objections, and the Commissioners or an Assistant Commissioner at such meeting shall hear and determine objections, or adjourn the further hearing thereof to a future meeting, and may take such measures for ascertaining the justice and propriety of the determinations and directions of the Valuer as may seem proper, and when they have heard and determined all

\* For a form of this report, see post p. 404, *et seq.*

objections, and made all requisite inquiries, the Commissioners shall approve such report, or cause the allotments, directions, determinations, and matters therein mentioned, or any of them, to be amended as they shall see occasion.

104. And be it enacted, that after such proceedings as aforesaid shall have been had, and all such objections to such report (if any) shall have been finally disposed of, and such amendments (if any) shall have been made in the allotments, directions, and matters therein contained as aforesaid, the Valuer, under the direction of the Commissioners, shall cause to be drawn up and engrossed on parchment the award in the matter of such enclosure, which shall be signed by the Valuer, and shall describe the boundaries, if any, which shall have been ascertained and set out under the provisions hereinbefore contained, and shall contain or set forth the report of the Valuer, or the allotments, exchanges, partitions, directions, and matters contained in such report, if so approved as aforesaid, or such allotments, exchanges, directions, and matters therein contained as the same shall have been amended as aforesaid, and shall contain a declaration whether all or any, and which of the mines, minerals, stone, and other substrata shall or shall not have been included in the estimate of the right and interest of the lord in the soil (in respect of which any allotment shall have been made to him), and the Valuer shall annex to such engrossment the map referred to by such report; and the Commissioners shall confirm such award with the date of such confirmation thereunto annexed, under their hands and seal.

105. The confirmation of an award is conclusive evidence that all the directions of this Act have been obeyed.

106. Allotments under any enclosure shall be taken and be in compensation of lands, rights of common and other rights previously held, and from the confirmation of the award all rights shall be extinguished.

107. If persons wish their allotments subdivided, the Commissioners may do so within two years of the award.

108. The allotment for the labouring poor shall be under the management of the incumbent of the parish, one churchwarden, and two persons to be yearly chosen by persons choosing the overseers of the poor. They shall be called allotment wardens, and shall manage and let the allotments as hereinafter provided.

109. The allotment wardens shall let the allotments, not exceeding a quarter of an acre each, to poor inhabitants of the parish for one year, or from year to year, the gardens to be free from all rates and taxes, and to be valued by a competent person before the first letting thereof, and every ten years for the purpose of estimating the rent. The rent at which the allotments are let shall not be below the full yearly value of the land, according to the last of such valuations. No building shall be erected on the allotments.

110. Provides for the recovery of the allotment gardens by the wardens, on non-payment of rent or other events mentioned.

111. In case of any one refusing to deliver up possession, or unlawfully taking possession, the wardens may act as if landlords, under the Act 1 and 2 Vict., cap. 74.

112. All rents shall be paid to the wardens, who shall have the same remedies for recovery thereof by distress and otherwise, as if the legal estate were in them. The rents are first to be applied to the payment of rates, tithes, and taxes, of the rent-charge on the allotment, and of all expenses incurred by the allotment wardens; and the residue shall be paid to the overseers of the poor, in aid of poor-rates.

113. The Commissioners, on the application in writing of persons interested in land about to be enclosed, whose interest shall exceed in value one-half of the

whole interest in such land (such application to be before the instructions to the Valuer have been finally settled), may direct such land, or any part thereof, to be converted into, and used as a regulated pasture to be stocked and depastured in common by the persons interested therein, in proportion to their respective rights and interests, as the same shall be determined on the examination of claims. If only part of the land is to be so used, the Valuer acting under the provisions of this Act, shall set out such part and shall direct how and at whose expense it is to be fenced and divided from the residue of the land. The Valuer shall allot the respective stints (specifying the respective numbers of the respective kinds of stock or animals to be admitted to the pasture, in respect of such stints, and also the time they are to be kept on the pasture), according to the proportional value of the various interests. The Commissioners may frame directions, as they shall think fit, for guiding the Valuer in a correct specification of such stints. In every case where only a part of the land shall be used as a regulated pasture, and the residue thereof shall be divided and used in severalty, the Valuer may award either a stint or right of pasture, or an allotment in severalty, only or both, as the case may be, so that the whole allotment is proportionate to the right and interest of the person. When the proportionate right or interest is too small for a stint, and no allotment can conveniently be made, the Valuer may direct a sum of money to be paid to the person, in lieu of, or in addition to, the stint or right of pasture, as the case may be, such money to be paid out of the monies applicable to the payment of the expenses of the enclosure.

114. All lands converted into regulated pastures shall be deemed enclosures.

115. The owners of the several stints or right of pasture shall be liable to pay any sum of money which shall be raised by way of rate under the provisions of this Act, in the proportions determined by the Valuer, subject to the approval of the Commission.

116. The right of soil in all land converted into regulated pastures shall, subject to the right of the lord of the manor to subtrata where the same are reserved to him under the Act, be vested in the owners of stints therein personally as tenants in common.

117. Provides for the election of field reeves of regulated pastures.

118. The duties of field reeves.

119. Provides for a rateable increase or diminution of rights in a regulated pasture.

120. All salaries and allowances to field reeves and other persons, and all expenses in and about the management of the regulated pasture, shall be paid by the owners of the respective stints—under the direction of a meeting of owners an adequate rate shall be made by the field reeve. He may exclude from pasture the stock of any person who has left his rate unpaid for fourteen days after application.

121. Pastures already stinted may be made into regulated pastures, provided the persons whose interests shall not be less than two-thirds of the whole interests therein, shall apply in writing to the Commissioners to take proceedings for that purpose. A Valuer to be appointed by the Commissioners shall find out the respective proportionate rights and interests of the owners, and shall determine and direct the proportionate liability to rates under this Act, of the occupiers of the stint, and shall send a report to be approved by the Commissioners. On the confirmation of such award, the land shall be subject to all the rules and regulations of regulated pasture.

122. All expenses of or attending the proceedings described in the last section,

shall be paid and borne by the persons interested therein in proportion to their liabilities to rates under this Act, the Valuer, with the approval of Commissioners, fixing the time and place of payment of the rates and to whom they shall be paid.

123. A general survey admeasurement plan or valuation may be taken, if any land proposed to be enclosed, by the Commissioners, Assistant Commissioner, Valuer, or any other person they may think fit to appoint, and the lands may be entered by them at any time until the Act shall be completed.

124. All allowances and payments to be made to and by the Valuer, which have been audited and approved by or under the direction of the Commissioners, and all other the expenses of every enclosure (except the salaries of the Commissioners and other expenses directed to be otherwise paid), shall be borne and defrayed by the several persons interested in the lands to be enclosed, except the surveyor of highways, churchwardens, overseers, and persons to whom land shall be allotted for public purposes, in such proportions as the Valuer may direct, with the approval of the Commissioners. The Valuer shall give notice requiring payment of such expenses, and shall make estimates of all such expenses, and shall raise them, when, with the sanction of the Commissioners, he shall think proper.

125. Before the Commissioners shall approve the estimates, they shall be submitted to a meeting of persons interested.

126. If any person shall refuse or neglect to pay his proportion of such expenses within such time and to such person as the Valuer shall appoint, it shall be lawful for the Valuer to recover the same, together with lawful interest, to be computed from the day on which the same ought to have been paid, by action at law in his own name in any of her Majesty's Courts of Record at Westminster: or it shall be lawful for him, by warrant directed to any person whomsoever, to cause the same, with such interest thereon as aforesaid, to be levied by distress; or it shall be lawful for the Valuer, or any person whomsoever authorised by him, immediately after such neglect or refusal, to enter into and upon the premises so to be allotted to such person, and demise the same, or to demise any stint or right of pasture allotted to such person, and receive the rents and profits thereof respectively, until thereby or otherwise such share or proportion, with lawful interest as aforesaid, and also all the costs and expenses attending such entry upon and demise and receipt of the rents and profits of the said premises, shall be fully paid and satisfied: provided always, that no such action at law as aforesaid shall be brought by the Valuer against any person for his proportion of such expenses as aforesaid, nor shall any proceeding be taken to levy any such proportion of expenses by distress as aforesaid, before the expiration of thirty days after notice in writing that such proportion of expenses is in arrear, and requiring payment thereof, shall have been given to the person liable to pay the same, or left at the usual place of abode of such person.

127. The Valuer may raise additional rates for payment of expenses if the first is found insufficient.

128. The Valuer or surveyor may at any time be discharged by the Commissioners, if incapable of acting by sickness, or for any other reason, and another may be appointed by them.

129. The Valuer shall not be able to purchase lands in the parish in which an enclosure shall have taken place for seven years after the award.

130. The Commissioners may order a sum of money to be paid to the Assistant Commissioner or others specially employed on the enclosure, and the same to be charged on persons interested in the land in such shares as they shall think just,

and shall appoint a time for payment thereof; and the same shall be raised in the same manner as the expenses of an enclosure.

131. Persons interested in the enclosure attending meetings concerning it shall pay their own expenses.

132. The Commissioners may order the expenses of witnesses and the production of books, deeds, court-rolls, maps, &c., to be paid by the parties interested in the production thereof, and may, when they think fit, require security for such payment.

133. Allotments may be mortgaged to pay expenses of an enclosure.

134. The Commissioners may direct a sale of parts of allotments to pay the expenses of an enclosure.

135. Such sale shall be made by the Valuer with the approbation of the Commissioners in the manner prescribed, for the sale of land, towards defraying the expenses of the enclosure.

136. The Commissioners shall receive and apply the purchase-money in paying the expenses for which such sale shall have been had, and if any surplus remains, it shall be paid to the parties from whose allotments such sale shall have been so made respectively.

137. When any money is, under the provisions of this Act, directed to be paid for the purchase of any timber or wood growing on any land which shall belong to any tenant for life, or in tail, or to any feoffee in trust, executor, or administrator, husband, guardian, committee, or trustee, for or on behalf of any infant, idiot, lunatic, feme covert, or cestui que trust, or to any person whose lands are limited in strict or other settlement, or to any person under any other disability or incapacity whatsoever, or to any corporation not being legally and equitably entitled to sell and dispose of such timber and wood, it shall be lawful for the Valuer, out of such money, to defray the proportion (if any) of the enclosure expenses, which shall be charged upon the land, or any land held under the same title, on which such timber or wood actually grew, and also, with the approbation of the Commissioners to defray the expense of any permanent improvement, such as building, subdividing, draining, or planting, and the like, which shall in the judgment of the Valuer be proper to be made, and shall be made, under his direction, upon any land to be, under the powers of this Act, allotted to such parties.

138. When there is a surplus of two hundred pounds or more, the same shall be paid into the Bank of England, in the name and with the privity of the Accountant-General of the Court of Chancery.

139. Until such money is paid out of court, dividends shall be paid to the parties who are entitled to the rents and profits of the land.

140. If the surplus is more than twenty, but less than two hundred pounds, it shall be paid into the Bank of England as aforesaid, or placed in the hands of two trustees at the option of the persons entitled to the rents and profits, or the guardians or committees of the persons under disability.

141. A surplus under twenty pounds shall be paid to the parties for the time being entitled to the rents and profits of the said land, or in case of infancy or other incapacity, to their guardians, committees, or trustees.

142. The Valuer may sell part of the land to be enclosed, if necessary, to pay expenses, at such time and in such manner as he shall think fit, subject to the approbation of the Commissioners.

143. The Commissioners shall make conveyances in the form given in the schedule to the Act.

144. All purchase-money from time to time raised by the Commissioners

shall go towards the expenses of the enclosure, and the persons paying the same shall not be liable for any misapplication thereof.

145. Notice of an intended enclosure may at any step of it be given by the Commissioners to reversioners.

146. Two copies of the confirmed award shall be made by the Commissioners, one to be lodged with the clerk of the peace for the county where the land enclosed is situated; and the other, with the church or chapel wardens of the parish where such land is situate to be kept by them and their successors in office with other public records of the parish. Copies certified by the clerk of the peace are to be evidence.

147. Exchanges may be made of land not subject to be enclosed.

148. Divisions may be made of intermixed lands.

149. Inconvenient allotments for the poor and public purposes may be exchanged for more convenient land.

150. Provided no order of exchange be confirmed by the Commissioners until due notice has been given by advertisement during three weeks, and until three months has expired since the last advertisement.

151. Provides for payment of expenses of exchanges and divisions.

152. Commissioners may remedy defects and omissions of awards under local Acts of enclosure or under 6 and 7 Will. IV., c. 115.

153. Commissioners may revive powers under local enclosure Acts lost by lapse of time or otherwise.

154. Commissioners may appoint persons to complete proceedings in an imperfect enclosure.

155. Commissioners are to give notice before proceeding to amend awards under local Acts.

156. Provides for cases where dealings have been had with lands on faith of inaccuracies, &c., proposed to be rectified.

157. Commissioners may confirm awards or agreements made under the supposed authority of 6 and 7 Will. IV., c. 115.

158. Contains a power to reduce the number of trustees under a local Act where a sufficient number of persons qualified cannot be found.

159. Provides for the recovery of penalties and forfeitures.

160. Specifies the mode of making distress.

161. Distresses are not unlawful for informality, but damage may be recovered by an action on the case.

162. All notices by this Act directed to be given by advertisement, shall be given by an advertisement to be inserted in some newspaper or newspapers printed or usually circulated in the county in which the land subject to be enclosed, or other land to which such notice shall relate, shall be situate; and all notices directed to be given on the church door shall be by writing under the hand of the party giving such notice, to be affixed on the principal outer door of the church of every parish and ecclesiastical district in which the land subject to be enclosed, or other land to which such notice shall relate, or any part thereof, shall be situate, on Sunday before divine service, or where in any such parish or ecclesiastical district there shall be no church, then to be affixed in some conspicuous place of such parish or ecclesiastical district, on Sunday before ten of the clock in the forenoon; and all notices necessary to be given by the Commissioners, or any Assistant Commissioner or Valuer, acting in the matter of any enclosure (the mode of giving which is not hereby particularly directed) shall be by either or both of the methods aforesaid, as the Commissioners or Assistant Commissioner or Valuer

respectively shall think fit; and all notices so given shall be deemed sufficient notices to all persons concerning all matters and things to which such respective notices shall relate.

163. Advertisements, awards, agreements, bonds, and powers of attorney, used under the Act are free of duty.

164. Persons giving false evidence, or refusing to attend to give evidence, or withholding documents, shall be guilty of a misdemeanour.

165. No action or suit against any Commissioners, Assistant Commissioner, Valuer, or any other persons for anything done under this Act, shall be begun before a notice of two months shall have elapsed, or after sufficient tender of amendments, or after twelve months from the commencement of the Act complained of.

166. Proceedings by Commissioners or Assistant Commissioner are not to be removed by certiorari.

167. Interpretation clause.

168. Act shall only extend to England and Wales.

169. Act may be amended or repealed during this session.

#### FORM OF VALUER'S REPORT ISSUED BY THE ENCLOSURE COMMISSIONERS.

TO ALL TO WHOM THESE PRESENTS SHALL COME, I, \_\_\_\_\_ of the  
parish of \_\_\_\_\_ in the county of \_\_\_\_\_ land surveyor,  
send greeting.

Whereas, the enclosure of \_\_\_\_\_ situate in the  
of \_\_\_\_\_ in the county of \_\_\_\_\_ has been duly author-  
ised under the provisions of the Acts for the enclosure, exchange, and improve-  
ment of land.

And whereas I, the said \_\_\_\_\_ have been appointed the Valuer in  
the matter of the said enclosure, and having made the declaration required by  
the said Acts, have duly held all necessary meetings, and in all other respects  
complied with the provisions of the said Acts; and all acts and matters, which,  
under the same Acts ought to be done and completed previous to the report of  
the Valuer, have been duly done and completed.

*Map of old enclosures dispensed with.*—And whereas the Enclosure Commis-  
sioners for England and Wales have, by an order under their seal, by virtue of  
the power vested in them in that behalf by the said Acts, directed that the lands  
in respect of which allotments are hereby made, shall not be comprised or shown  
on the map hereunto annexed.

*Old enclosures, sect. 86.*—And whereas \_\_\_\_\_ of  
the person interested in a certain old [insert tenure. If copyhold, the consent of  
the lord of the manor must be obtained; if glebe the consent of the bishop and  
patron.] Enclosure numbered \_\_\_\_\_ on the map hereunto annexed, situate  
in the said parish of \_\_\_\_\_ has given his consent in writing, to the  
same being considered allottable and parcel of the land to be enclosed.

*Disputed boundary.*—And whereas I represented to the said Enclosure Commis-  
sioners that the boundaries of the said parish of \_\_\_\_\_  
and of the manor of \_\_\_\_\_ and of the adjoining parish  
and manor of \_\_\_\_\_ in the said county, were not sufficiently ascer-  
tained and distinguished, and \_\_\_\_\_ of \_\_\_\_\_ Esquire,  
an Assistant-Commissioner under the said Acts, having been duly appointed to

ascertain and set out the said boundaries, awarded, adjudged, and determined the boundary between the said parishes and manors to be as follows, that is to say : [*Here describe the boundary line as in the boundary award.*]

Now know ye, that in pursuance of the provisions of the said Acts, and by virtue of the powers and authorities in me vested, I, the said the Valuer as aforesaid, do make and declare this to be my report in the matter of the said enclosure, and to this my report I have annexed a map, as required by the said Acts.

*Old enclosures.*—And I declare, that the said old enclosure, numbered

on the said map, shall be considered as allottable and parcel of the land to be enclosed.

*Roads stopped up or diverted.*—And I further declare, that I have discontinued and stopped up the public roads and ways in the said parish, hereinafter particularly mentioned, that is to say :—

A certain public carriage road or highway leading [*describe the public carriage bridle and footways stopped up; and afterwards, any diverted.*]

*Public roads.*—And I do hereby declare, that I have set out and appointed, and do hereby set out and appoint, the following public carriage roads or highways, that is to say :—

One public carriage road, or highway, of the width of                      feet to be called                      commencing at a point marked                      on the said map, and extending thence [*here describe the roads with proper references to the map*] to and terminating at

One other public carriage road—

[NOTE.—*The certificate of the justices, under the 67th sect. of the Act, must be produced before the award can be confirmed.*]

*Occupation roads.*—And I further declare, that I have set out and appointed, and do hereby set out and appoint, the following private carriage and occupation roads, that is to say :—

One private carriage and occupation road of the width of                      feet and numbered                      on the said map, commencing at                      and extending thence [*describe the road*] to and terminating at                      which said road is set out for the use of the persons interested for the time being in the [*occupation roads may also be set out for the use of persons interested in old enclosures, and the repairs charged on the owner and proprietor of such old enclosures*] allotments numbered. [*If more than one, state the proportion, or the repairs may be by rate.*].—And I direct and appoint that the said private carriage and occupation road shall for ever hereafter be maintained and repaired by the owner and proprietor of the allotment numbered [*repeat for each occupation road, commencing—“ One other private,” &c.*]

*Public footways.*—And I declare that I have set out and appointed, and do hereby set out and appoint, the following public footways, that is to say,—

One public footway of the width of                      feet numbered on the said map, commencing at                      and extending thence to, and terminating [*describe the footway.*]

*Private footways.*—And I declare that I have set out and appointed, and do hereby set out and appoint, the following private footways, that is to say,—

One private footway of the width of                      feet numbered on the said map, commencing at                      and extending thence to, and terminating [*describe the footway. Query repairs.*]



*Public ponds.*—And I declare that I have set out and appointed, and do hereby set out and appoint, the following public ponds or watering-places, that is to say,—

One public pond, numbered \_\_\_\_\_ on the said map, situate at [*describe the situation*], which said pond shall be from time to time, properly cleansed and repaired by \_\_\_\_\_

*Water-courses.*—And I declare that I have set out and appointed, and do hereby set out and appoint, the following public water-courses, that is to say,

One public water-course numbered \_\_\_\_\_ on the said map [*the depth and width at top and bottom should be given*], commencing at \_\_\_\_\_ and extending thence to \_\_\_\_\_, and terminating at \_\_\_\_\_ [The repairs may be by rate, or by the owners and proprietors of particular allotments, as the valuer may think best.]—And I declare and direct that the expense of cleansing, repairing, and maintaining the said water-course shall be raised by rate, to be levied on the allotments next hereinafter set forth, in the proportions following, that is to say,—

No. of allotment.	Proportion of rate to be levied on allotment.
-------------------	---

"	"
"	"

(Or this may be put in the schedule by adding a column.)

[NOTE.—The expense of repairing private roads, embankments, bridges, &c., may be directed to be raised by rate in like manner.]

*Quarry allotment.*—And I declare that I have set out, and do hereby set out, allot, and award unto the surveyors of the highways of the said parish of \_\_\_\_\_ and their successors for ever, all that piece or parcel of ground numbered \_\_\_\_\_ on the said map, and containing by admeasurement, A. B. P. And I direct that such allotment, piece, or parcel of ground, shall be appropriated and used as a public quarry for supplying stone and gravel for the repairs of the roads and ways within the said parish. And I direct that the fences on the \_\_\_\_\_ sides of such allotment, shall from time to time be repaired and maintained by \_\_\_\_\_ and at the expense of \_\_\_\_\_

*Recreation allotment.*—And I declare that I have set out, and do hereby set out, allot, and award unto the churchwardens and overseers of the poor of the said parish of \_\_\_\_\_ all that piece or parcel of land numbered \_\_\_\_\_

\_\_\_\_\_ on the said map, containing A. B. P. to be held by them and their successors, in trust, as a place for exercise and recreation for the inhabitants of the said parish and neighbourhood. And I direct that the fences on the \_\_\_\_\_ sides of such allotment, shall from time to time be repaired and maintained by \_\_\_\_\_ and at the expense of the churchwardens and overseers of the poor of the said parish for the time being.

*Poor's allotment.*—And I have also set out, and do hereby set out, allot, and award unto the said churchwardens and overseers of the poor all that piece or parcel of land numbered \_\_\_\_\_ on the said map, containing A. B. P.

\_\_\_\_\_ to be held by them and their successors in trust, as an allotment for the labouring poor of the said parish of \_\_\_\_\_, subject, nevertheless, to and chargeable with a clear rent charge of £ \_\_\_\_\_, which said sum does not exceed the net annual value of the said allotment in its present condition. [It is absolutely necessary that a rent charge should be set upon the allotment for the labouring poor, which must be awarded to some of the persons interested, or may be sold by the Valuer towards payment of the enclosure expenses, if instructions be given

to that effect.] And I declare the same to be of the value of such number of imperial bushels, and decimal parts of an imperial bushel of wheat, barley, and oats, as hereinafter set forth, that is to say—

	Price per bushel.	Bushels and decimal parts.
	s. d.	
Wheat . . .	7 0½	
Barley . . .	3 11½	
Oats . . .	2 9	

And I direct that the fences on the \_\_\_\_\_ sides of such allotment, shall from time to time be repaired and maintained by and at the expense of the churchwardens and overseers of the poor of the said parish for the time being

[if any other allotments for public purposes, the same to be here

set out.]

And I, the said \_\_\_\_\_, do hereby declare that I have, in pursuance of instructions duly given in that behalf, and with the approbation of the said Inclosure Commissioners, sold such parts of the land to be inclosed as are next hereinafter particularly mentioned for the purpose of raising money to defray the expenses incident to the said inclosure, for the several prices, and the same have been conveyed in fee by the said Inclosure Commissioners to the several persons hereinafter mentioned, that is to say,—

Unto \_\_\_\_\_ of \_\_\_\_\_ at or for the price or sum of £ \_\_\_\_\_ all that piece or parcel of land numbered \_\_\_\_\_ on the said map, and containing A. R. P. of which the fences on the \_\_\_\_\_ and \_\_\_\_\_ sides are to be made and for ever hereafter maintained and repaired by the owner of such piece or parcel of land.

Repeat for each sale allotment.—Unto

*Manorial Allotment.*—And I have also set out, and do hereby set out, allot, and award, unto \_\_\_\_\_ the lord of the manor of \_\_\_\_\_ all that piece or parcel of land numbered \_\_\_\_\_ on the said map, and containing A. R. P. which I adjudge and declare to be equal in value to \_\_\_\_\_ part of the residue of the lands to be inclosed, and to be in lieu and in full compensation for the right and interest of the said \_\_\_\_\_

[as the case may be] in the soil of the said lands (exclusively) (inclusively) of his right and interest in all mines, minerals, stone, and other substrata under the same. And I direct that the fences on the \_\_\_\_\_ sides thereof shall be made and maintained by the owner, for the time being, of the said allotment.

*Where mines are not reserved, strike out this clause.*—And I further declare that I do, on the request in writing of the said lord of the manor, reserve and set out to the said lord, all mines, minerals, stone, and other substrata under the lands to be inclosed, with full power and authority for him, his heirs, lessees, and assigns, and his and their agents, miners, and servants, at all times hereafter to enter upon all or any part of the said land, to search for, work, and carry away all mines, minerals, stone, and other substrata under the said lands; and to do all necessary or reasonable acts for the convenient exercise of this power and authority, he and they paying reasonable and adequate compensation to the persons entitled to the surface of such land, for damage done to such surface in the exercise of the rights and easements intended to be hereby reserved.

*Allotment of residue.*—And I further declare that I have set out all the remainder of the said \_\_\_\_\_ (and set out the stints or rights on the regulated pasture hereinafter set forth) among the several persons hereinafter named, being

all the persons interested therein in the shares or allotments following, set opposite to their respective names, which allotments (and stints or rights) I have adjudged and determined to be proportionate to the value of the respective rights and interest of such several persons, which have been claimed and allowed under the provisions of the said Acts, that is to say, I do set out, allot and award unto

Persons interested.	ALLOTMENTS.				Proportion of rate for repairing.	Lands in respect of which claims allowed and allotments made.						
	Residence and Description.	No. on Map.	Extent.			Fences to be made and maintained by owner.	To be levied on allotment.	No. on Map.	Description.		Extent.	Tenure.
			A.	R.					P.	£		

*Allotment of rent charge.*—And I further set out, allot, and award the said rent charge of £                      payable out of the allotment for the labouring poor, unto and amongst the several persons, and in the proportions hereinafter mentioned, that is to say,—                      £   s.   d.

Unto

*Fences.*—And I, the said                      do hereby order, direct, and appoint that good and sufficient fences, for inclosing the several allotments hereinbefore described, if not already set up and made, shall be made within the space of                      months from the confirmation by the said Inclosure Commissioners of my award, by the several persons, owners for the time being of the said several allotments on the sides hereinbefore in that behalf prescribed, on which sides respectively a star is marked or drawn thus (\*) on the said map.

*Exchanges.*—And I do hereby, with the consent in writing of the persons interested in the land exchanged, as hereinafter mentioned, set out, allot, and award such parts of the land to be inclosed as are next hereinafter specified in exchange for the other land in the said parish, hereinafter also particularly described, that is to say,—

Unto                      of                      all that allotment numbered                      on the said map                      A.   R.   P.   in exchange for all that piece or parcel of old inclosed [*Tenure*]                      land, situate in the said parish of                      and numbered                      on the said map, and containing                      A.   R.   P.   which said piece or parcel of old inclosed land, I hereby set out and award unto                      of

in exchange for the said allotment, numbered \_\_\_\_\_ as afore-  
 said  
*Repeat for each exchange, commencing unto, &c.*—Unto \_\_\_\_\_ of  
 all that allotment numbered \_\_\_\_\_ on the said map,  
 containing A. R. P. in exchange for all that piece or parcel of old  
 inclosed [*Tenure*] \_\_\_\_\_ land, situate in the said parish of  
 and numbered \_\_\_\_\_ on the said map, and containing A. R. P.  
 which said piece or parcel of old inclosed land, I hereby set out and award unto  
 of \_\_\_\_\_ in exchange for the said allotment,  
 numbered \_\_\_\_\_ as aforesaid

LIST OF ACTS RELATING TO THE INCLOSURE OF LAND, PASSED  
 SINCE 1845.

1. Acts amending or extending the General Inclosure Act 1845. (9 & 10 *Vict. c. 70* ; 10 & 11 *Vict. c. 111* ; 11 & 12 *Vict. c. 99* ; 12 & 13 *Vict. c. 83* ; 14 & 15 *Vict. c. 53* ; 15 & 16 *Vict. c. 79* ; 17 & 18 *Vict. c. 97* ; 20 & 21 *Vict. c. 31* ; 22 & 23 *Vict. c. 43*.)
2. "The Inclosure and Copyhold Commissioners' Consolidation Act" (14 & 15 *Vict. c. 53*). By this and subsequent Acts the appointment of the Inclosure Commissioners has been continued to the present time.
3. "The Metropolitan Commons Act, 1866" (29 and 30 *Vict. c. 122*).





L  
H

3

6



TURNPIKE.

B

2

4

*A Rough*  
**PLAN**  
*of the engraven*  
**FIELD BOOK.**  
*see the 1st. &c.*

ts.

A.	R.	P.
1	0	20
2	2	38
2	0	10
13	1	28
11	0	9
12	2	18
<hr/>		
43	0	3

HILL







2

.

.

.....

.....







hains

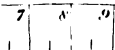







1  
2  
3

37  
43  
50  
57  
65

724	17			
800	18	4034	4164	
877	19	4138	4224	
956	19	4244	4304	
1037	20	4352	4494	
		4461	454	
1119	21	6		
1203	22	44572	464	
1289	23	36	4684	474
1376	24	19	4798	485
1465	25	104	4914	505
			0,5031	515
1555	26	02		
1647	26	39	5150	525
1741	27	88	5271	535
1836	28	590	5393	545
1933	29	83	3,5517	555
			37,5643	554

1032	30	82		
1132	31	83	64,5770	560
1234	32	86	92,5898	562
1338	33	90	121,6029	563
1443	34	96	152,6161	564
			185,6294	566
1549	36	04		
1658	37	13	320,6430	567
1768	38	24	356,6566	568
1880	39	37	393,6705	569
1993	40	51	433,6845	570
			476,6988	571

68			
1303	69		
1470	11638	70	
1639	11808	11978	71

1107	41	66	42	
1224	42	84	018,7132	72
			161,7276	73
			1809,11979	12150,12322
			1981,12151	12323,12497,12672





# GENERAL LIST OF WORKS

PUBLISHED BY

Messrs. LONGMANS, GREEN, READER, and DYER.

ARTS, MANUFACTURES, &c.....	12	MISCELLANEOUS and POPULAR META- PHYSICAL WORKS.....	6
ASTRONOMY, METEOROLOGY, POPULAR GEOGRAPHY, &c.....	7	MUSICAL PUBLICATIONS .....	11
BIOGRAPHY and MEMOIRS .....	3	NATURAL HISTORY and POPULAR SCIENCE.....	7
CHEMISTRY, MEDICINE, SURGERY, and the ALLIED SCIENCES .....	9	POETRY and THE DRAMA.....	17
COMMERCE, NAVIGATION, and MERCAN- TILE AFFAIRS .....	19	RELIGIOUS and MORAL WORKS .....	13
CRITICISM, PHILOLOGY, &c.....	4	RURAL SPORTS, &c.....	18
FINE ARTS and ILLUSTRATED EDITIONS	11	TRAVELS, VOYAGES, &c.....	15
HISTORICAL WORKS.....	1	WORKS OF FICTION .....	16
INDEX .....	21—24	WORKS OF UTILITY and GENERAL INFORMATION .....	19
KNOWLEDGE for the YOUNG .....	20		

## Historical Works.

**Lord Macaulay's Works.** Complete and uniform Library Edition. Edited by his Sister, Lady TREVELYAN. 8 vols. 8vo. with Portrait, price £5 5s. cloth, or £8 8s. bound in tree-calf by Rivière.

**The History of England from the Fall of Wolsey to the Death of Elizabeth.** By JAMES ANTHONY FROUDE, M.A. late Fellow of Exeter College, Oxford. VOLS. I. to X. in 8vo. price £7 2s. cloth.

VOLS. I. to IV. the Reign of Henry VIII. Third Edition, 54s.

VOLS. V. and VI. the Reigns of Edward VI. and Mary. Second Edition, 28s.

VOLS. VII. & VIII. the Reign of Elizabeth, VOLS. I. & II. Fourth Edition, 28s.

VOLS. IX. and X. the Reign of Elizabeth. VOLS. III. and IV. 32s.

**The History of England from the Accession of James II.** By Lord MACAULAY.

LIBRARY EDITION, 5 vols. 8vo. £4.

CABINET EDITION, 8 vols. post 8vo. 48s.

PEOPLE'S EDITION, 4 vols. crown 8vo. 16s.

**Revolutions in English History.**

By ROBERT VAUGHAN, D.D. 3 vols. 8vo. 45s.

VOL. I. Revolutions of Race, 15s.

VOL. II. Revolutions in Religion, 15s.

VOL. III. Revolutions in Government, 15s.

**An Essay on the History of the English Government and Constitution, from the Reign of Henry VII. to the Present Time.** By JOHN EARL RUSSELL. Fourth Edition, revised. Crown 8vo. 6s.

**The History of England during the Reign of George the Third.** By the Right Hon. W. N. MASSEY. Cabinet Edition, 4 vols. post 8vo. 24s.

**The Constitutional History of England, since the Accession of George III. 1760—1860.** By Sir THOMAS ERSKINE MAY, K.C.B. Second Edit. 2 vols. 8vo. 38s.

**Brodie's Constitutional History** of the British Empire from the Accession of Charles I. to the Restoration. Second Edition. 3 vols. 8vo. 36s.

**Historical Studies.** I. On Precursors of the French Revolution; II. Studies from the History of the Seventeenth Century; III. Leisure Hours of a Tourist. By HERMAN MERIVALE, M.A. 8vo. 12s. 6d.

**Lectures on the History of England.** By WILLIAM LONGMAN. VOL. I. from the Earliest Times to the Death of King Edward II. with 6 Maps, a coloured Plate, and 53 Woodcuts. 8vo. 15s.

- History of Civilization in England and France, Spain and Scotland.** By HENRY THOMAS BUCKLE. Fifth Edition of the entire work, complete in 3 vols. crown 8vo. price 24s. cloth; or 42s. bound in tree-calf by Rivière.
- The History of India, from the Earliest Period to the close of Lord Dalhousie's Administration.** By JOHN CLARK MARSHMAN. 3 vols. crown 8vo.  
[*Nearly ready.*]
- Democracy in America.** By ALEXIS DE TOCQUEVILLE. Translated by HENRY REVE, with an Introductory Notice by the Translator. 2 vols. 8vo. 21s.
- The Spanish Conquest in America, and its Relation to the History of Slavery and to the Government of Colonies.** By ARTHUR HELPS. 4 vols. 8vo. £3. VOLS. I. & II. 28s. VOLS. III. & IV. 16s. each.
- History of the Reformation in Europe in the Time of Calvin.** By J. H. MERLE D'AUBIGNÉ, D.D. VOLS. I. and II. 8vo. 28s. VOL. III. 12s. and VOL. IV. price 16s. VOL. V. in the press.
- Library History of France, in 5 vols. 8vo.** By EYRE EVANS CROWE. VOL. I. 14s. VOL. II. 15s. VOL. III. 18s. VOL. IV. 18s.
- Lectures on the History of France.** By the late Sir JAMES STEPHEN, LL.D. 2 vols. 8vo. 24s.
- The History of Greece.** By C. THIRLWALL, D.D. Lord Bishop of St. David's. 8 vols. fcp. with Vignette-titles, 28s.
- The Tale of the Great Persian War, from the Histories of Herodotus.** By GEORGE W. COX, M.A. late Scholar of Trin. Coll. Oxon. Fcp. 7s. 6d.
- Greek History from Themistocles to Alexander, in a Series of Lives from Plutarch.** Revised and arranged by A. H. CLOUGH. Fcp. with 44 Woodcuts, 6s.
- Critical History of the Language and Literature of Ancient Greece.** By WILLIAM MURE, of Caldwell. 5 vols. 8vo. £3 9s.
- History of the Literature of Ancient Greece.** By Professor K. O. MÜLLER. Translated by the Right Hon. Sir GEORGE CORNEWALL LEWIS, Bart. and by J. W. DONALDSON, D.D. 3 vols. 8vo. 86s.
- History of the City of Rome from its Foundation to the Sixteenth Century of the Christian Era.** By THOMAS H. DYER, LL.D. 8vo. with 2 Maps, 15s.
- History of the Romans under the Empire.** By CHARLES MERIVALE, B.D. Chaplain to the Speaker. Cabinet Edition, with Maps, complete in 8 vols. post 8vo. 48s.
- The Fall of the Roman Republic: a Short History of the Last Century of the Commonwealth.** By the same Author. 12mo. 7s. 6d.
- The Conversion of the Roman Empire; the Boyle Lectures for the year 1864, delivered at the Chapel Royal, Whitehall.** By the same. 2nd Edition. 8vo. 8s. 6d.
- The Conversion of the Northern Nations; the Boyle Lectures for 1865.** By the same Author. 8vo. 8s. 6d.
- Critical and Historical Essays** contributed to the *Edinburgh Review*. By the Right Hon. Lord MACAULAY.  
LIBRARY EDITION, 3 vols. 8vo. 36s.  
CABINET EDITION, 4 vols. post 8vo. 24s.  
TRAVELLER'S EDITION, in 1 vol. 21s.  
POCKET EDITION, 3 vols. fcp. 21s.  
PEOPLE'S EDITION, 2 vols. crown 8vo. 8s.
- History of the Rise and Influence of the Spirit of Rationalism in Europe.** By W. E. H. LECKY, M.A. Third Edition. 2 vols. 8vo. 25s.
- The History of Philosophy, from Thales to the Present Day.** By GEORGE HENRY LEWES. Third Edition, partly rewritten and greatly enlarged. In 2 vols. VOL. I. *Ancient Philosophy*; VOL. II. *Modern Philosophy*. [Nearly ready.]
- History of the Inductive Sciences.** By WILLIAM WHEWELL, D.D. F.R.S. late Master of Trin. Coll. Cantab. Third Edition. 3 vols. crown 8vo. 24s.
- Egypt's Place in Universal History; an Historical Investigation.** By C. C. J. BUNSEN, D.D. Translated by C. H. COTTRELL, M.A. With many Illustrations. 4 vols. 8vo. £5 8s. VOL. V. is nearly ready, completing the work.
- Maunder's Historical Treasury; comprising a General Introductory Outline of Universal History, and a Series of Separate Histories.** Fcp. 10s.
- Historical and Chronological Encyclopædia, presenting in a brief and convenient form Chronological Notices of all the Great Events of Universal History.** By B. B. WOODWARD, F.S.A. Librarian to the Queen. [In the press.]

**History of the Christian Church,** from the Ascension of Christ to the Conversion of Constantine. By E. BURTON, D.D. late Regius Prof. of Divinity in the University of Oxford. Eighth Edition. Fcp. 3s. 6d.

**Sketch of the History of the Church of England to the Revolution of 1688.** By the Right Rev. T. V. SHORT, D.D. Lord Bishop of St. Asaph. Seventh Edition. Crown 8vo. 10s. 6d.

**History of the Early Church,** from the First Preaching of the Gospel to the Council of Nicaea, A.D. 325. By the Author of 'Amy Herbert.' Fcp. 4s. 6d.

**History of Wesleyan Methodism.** By GEORGE SMITH, F.A.S. Fourth Edition, with numerous Portraits. 3 vols. crown 8vo. 7s. each.

**The English Reformation.** By F. C. MASSINGBERD, M.A. Chancellor of Lincoln. Fourth Edit. revised. Fcp. 7s. 6d.

### *Biography and Memoirs.*

**Life and Correspondence of Richard Whately, D.D.** late Archbishop of Dublin. By E. JANE WHATELY, Author of 'English Synonymes.' With 2 Portraits. 2 vols. 8vo. 28s.

**Extracts of the Journals and Correspondence of Miss Berry,** from the Year 1783 to 1832. Edited by Lady THERESA LEWIS. Second Edition, with 8 Portraits. 3 vols. 8vo. 42s.

**The Diary of the Right Hon. William Windham, M.P.** From 1783 to 1809. Edited by Mrs. H. BARING. 8vo. 18s.

**Life of the Duke of Wellington.** By the Rev. G. R. GLEIG, M.A. Popular Edition, carefully revised; with copious Additions. Crown 8vo. with Portrait, 5s.

**Life of the Duke of Wellington,** partly from M. BRIALMONT, partly from Original Documents (Intermediate Edition). By Rev. G. R. GLEIG, M.A. 8vo. with Portrait, 15s.

**Brialmont and Gleig's Life of the Duke of Wellington** (the Parent Work). 4 vols. 8vo. with Illustrations, £2 14s.

**Life of Robert Stephenson, F.R.S.** By J. C. JEAFFRESON, Barrister-at-Law; and WILLIAM POLE, F.R.S. Member of the Institution of Civil Engineers. With 2 Portraits and 17 Illustrations on Steel and Wood. 2 vols. 8vo. 32s.

**History of my Religious Opinions.** By J. H. NEWMAN, D.D. Being the Substance of Apologia pro Vitâ Suâ. Post 8vo. 6s.

**Father Mathew: a Biography.** By JOHN FRANCIS MAGUIRE, M.P. Popular Edition, with Portrait. Crown 8vo. 8s. 6d.

**Rome; its Rulers and its Institutions.** By the same Author. New Edition in preparation.

**Letters and Life of Francis Bacon,** including all his Occasional Works. Collected and edited, with a Commentary, by J. SPEDDING, Trin. Coll. Cantab. Vols. I. and II. 8vo. 24s.

**Some Account of the Life and Opinions of a Fifth-Monarchy Man,** chiefly extracted from the Writings of JOHN ROGERS, preacher. Edited by the Rev. EDWARD ROGERS, M.A. Student of Christ Church, Oxford. Crown 4to.

[*Nearly ready.*]

**Life of Amelia Wilhelmina Sieveking,** from the German. Edited, with the Author's sanction, by CATHERINE WINKWORTH. Post 8vo. with Portrait, 12s.

**Mozart's Letters (1769-1791),** translated from the Collection of Dr. LUDWIG NOHL by Lady WALLACE. 2 vols. post 8vo. with Portrait and Facsimile, 18s.

**Beethoven's Letters (1790-1826),** from the Two Collections of Drs. NOHL and VON KÜCHEL. Translated by Lady WALLACE. 2 vols. post 8vo. Portrait, 18s.

**Felix Mendelssohn's Letters from Italy and Switzerland,** and Letters from 1835 to 1847, translated by Lady WALLACE. With Portrait. 2 vols. crown 8vo. 5s. each.

**Recollections of the late William Wilberforce, M.P.** for the County of York during nearly 30 Years. By J. S. HARBORD, F.R.S. Second Edition. Post 8vo. 7s.

**Memoirs of Sir Henry Havelock, K.C.B.** By JOHN CLARK MARSHMAN. Second Edition. 8vo. with Portrait, 12s. 6d.

**Essays in Ecclesiastical Biography.** By the Right Hon. Sir J. STEPHEN, LL.D. Fourth Edition. 8vo. 14s.

**Biographies of Distinguished Scientific Men.** By FRANÇOIS ARAGO. Translated by Admiral W. H. SMYTH, F.R.S. the Rev. B. POWELL, M.A. and R. GRANT, M.A. 8vo. 18s.

**Vicissitudes of Families.** By Sir BERNARD BURKE, Ulster King of Arms. FIRST, SECOND, and THIRD SERIES. 3 vols. crown 8vo. 12s. 6d. each.

**Maunder's Biographical Treasury.** Thirteenth Edition, reconstructed and partly rewritten, with above 1,000 additional Memoirs, by W. L. R. CATES. Fcp. 10s. 6d.

### *Criticism, Philosophy, Polity, &c.*

**The Institutes of Justinian; with English Introduction, Translation, and Notes.** By T. C. SANDARS, M.A. Barrister-at-Law. Third Edition. 8vo. 15s.

**The Ethics of Aristotle with Essays and Notes.** By Sir A. GRANT, Bart. M.A. LL.D. Director of Public Instruction in the Bombay Presidency. Second Edition, revised and completed. 2 vols. 8vo. price 28s.

**On Representative Government.** By JOHN STUART MILL, M.P. Third Edition. 8vo. 9s. crown 8vo. 2s.

**On Liberty.** By the same Author. Third Edition. Post 8vo. 7s. 6d. crown 8vo. 1s. 4d.

**Principles of Political Economy.** By the same. Sixth Edition. 2 vols. 8vo. 80s. or in 1 vol. crown 8vo. 5s.

**System of Logic, Ratiocinative and Inductive.** By the same. Sixth Edition. 2 vols. 8vo. 25s.

**Utilitarianism.** By the same. 2d Edit. 8vo. 5s.

**Dissertations and Discussions.** By the same Author. 2 vols. 8vo. 24s.

**Examination of Sir W. Hamilton's Philosophy, and of the Principal Philosophical Questions discussed in his Writings.** By the same. Second Edition. 8vo. 14s.

**The Elements of Political Economy.** By HENRY DUNNING MACLEOD, M.A. Barrister-at-Law. 8vo. 16s.

**A Dictionary of Political Economy; Biographical, Bibliographical, Historical, and Practical.** By the same Author. Vol. I. royal 8vo. 80s.

**Lord Bacon's Works, collected and edited by R. L. ELLIS, M.A. J. SPEDDING, M.A. and D. D. HEATH.** VOLS. I. to V. *Philosophical Works*, 5 vols. 8vo. £4 6s. VOLS. VI. and VII. *Literary and Professional Works*, 2 vols. £1 16s.

**Bacon's Essays, with Annotations.** By R. WHATELY, D.D. late Archbishop of Dublin. Sixth Edition. 8vo. 10s. 6d.

**Elements of Logic.** By R. WHATELY, D.D. late Archbishop of Dublin. Ninth Edition. 8vo. 10s. 6d. crown 8vo. 4s. 6d.

**Elements of Rhetoric.** By the same Author. Seventh Edition. 8vo. 10s. 6d. crown 8vo. 4s. 6d.

**English Synonymes.** Edited by Archbishop WHATELY. 5th Edition. Fcp. 3s.

**Miscellaneous Remains from the Common-place Book of RICHARD WHATELY, D.D. late Archbishop of Dublin.** Edited by E. JANE WHATELY. Post 8vo. 7s. 6d.

**Essays on the Administrations of Great Britain from 1783 to 1830.** By the Right Hon. Sir G. C. LEWIS, Bart. Edited by the Right Hon. Sir E. HEAD, Bart. 8vo. with Portrait, 15s.

*By the same Author.*

**Inquiry into the Credibility of the Early Roman History,** 2 vols. 80s.

**On the Methods of Observation and Reasoning in Politics,** 2 vols. 28s.

**Irish Disturbances and Irish Church Question,** 12s.

**Remarks on the Use and Abuse of some Political Terms,** 9s.

**The Fables of Babrius, Greek Text with Latin Notes, PART I. 5s. 6d. PART II. 8s. 6d.**

**An Outline of the Necessary Laws of Thought: a Treatise on Pure and Applied Logic.** By the Most Rev. W. THOMSON, D.D. Archbishop of York. Crown 8vo. 5s. 6d.

**The Elements of Logic.** By THOMAS SHEDDEN, M.A. of St. Peter's Coll. Cantab. 12mo. 4s. 6d.

**Analysis of Mr. Mill's System of Logic.** By W. STEBBING, M.A. Second Edition. 12mo. 8s. 6d.

**The Election of Representatives, Parliamentary and Municipal; a Treatise.** By THOMAS HARE, Barrister-at-Law. Third Edition, with Additions. Crown 8vo. 6s.

**Speeches on Parliamentary Reform.** By the Right Hon. B. DISRAELI, M.P. Chancellor of the Exchequer. 1 vol. 8vo. [Nearly ready.]

**Speeches of the Right Hon. Lord MACAULAY,** corrected by Himself. Library Edition, 8vo. 12s. People's Edition, crown 8vo. 3s. 6d.

**Lord Macaulay's Speeches on Parliamentary Reform in 1831 and 1832.** 16mo. 1s.

**A Dictionary of the English Language.** By R. G. LATHAM, M.A. M.D. F.R.S. Founded on the Dictionary of Dr. S. JOHNSON, as edited by the Rev. H. J. TODD, with numerous Emendations and Additions. Publishing in 36 Parts, price 3s. 6d. each, to form 2 vols. 4to. VOL. I. in Two Parts, now ready.

**Thesaurus of English Words and Phrases,** classified and arranged so as to facilitate the Expression of Ideas, and assist in Literary Composition. By P. M. ROGET, M.D. 18th Edition, crown 8vo. 10s. 6d.

**Lectures on the Science of Language,** delivered at the Royal Institution. By MAX MÜLLER, M.A. Taylorian Professor in the University of Oxford. FIRST SERIES, Fifth Edition, 12s. SECOND SERIES, 18s.

**Chapters on Language.** By F. W. FARRAR, M.A. F.R.S. late Fellow of Trin. Coll. Cambridge. Crown 8vo. 8s. 6d.

**The Debater; a Series of Complete Debates, Outlines of Debates, and Questions for Discussion.** By F. ROWTON. Fcp. 6s.

**A Course of English Reading,** adapted to every taste and capacity; or, How and What to Read. By the Rev. J. PYCROFT, B.A. Fourth Edition, fcp. 5s.

**Manual of English Literature,** Historical and Critical: with a Chapter on English Metres. By THOMAS ARNOLD, M.A. Second Edition. Crown 8vo. 7s. 6d.

**Southey's Doctor,** complete in One Volume. Edited by the Rev. J. W. WARTER, B.D. Square crown 8vo. 12s. 6d.

**Historical and Critical Commentary on the Old Testament; with a New Translation.** By M. M. KALISCH, Ph. D. VOL. I. *Genesis*, 8vo. 18s. or adapted for the General Reader, 12s. VOL. II. *Exodus*, 15s. or adapted for the General Reader, 12s.

**A Hebrew Grammar, with Exercises.** By the same. PART I. *Outlines with Exercises*, 8vo. 12s. 6d. KEY, 5s. PART II. *Exceptional Forms and Constructions*, 12s. 6d.

**A Latin-English Dictionary.** By J. T. WHITE, D.D. of Corpus Christi College, and J. E. RIDDLE, M.A. of St. Edmund Hall, Oxford. Imp. 8vo. pp. 2,128, price 42s.

**A New Latin-English Dictionary,** abridged from the larger work of *White and Riddle* (as above), by J. T. WHITE, D.D. Joint-Author. 8vo. pp. 1,048, price 18s.

**The Junior Scholar's Latin-English Dictionary,** abridged from the larger works of *White and Riddle* (as above), by J. T. WHITE, D.D. surviving Joint-Author. Square 12mo. pp. 662, price 7s. 6d.

**An English-Greek Lexicon,** containing all the Greek Words used by Writers of good authority. By C. D. YONGE, B.A. Fifth Edition. 4to. 21s.

**Mr. Yonge's New Lexicon,** English and Greek, abridged from his larger work (as above). Square 12mo. 8s. 6d.

**A Greek-English Lexicon.** Compiled by H. G. LIDDELL, D.D. Dean of Christ Church, and R. SCOTT, D.D. Master of Balliol. Fifth Edition, crown 4to. 31s. 6d.

**A Lexicon, Greek and English,** abridged from LIDDELL and SCOTT'S *Greek-English Lexicon*. Eleventh Edition, square 12mo. 7s. 6d.

**A Sanskrit-English Dictionary,** The Sanskrit words printed both in the original Devanagari and in Roman letters; with References to the Best Editions of Sanskrit Authors, and with Etymologies and Comparisons of Cognate Words chiefly in Greek, Latin, Gothic, and Anglo-Saxon. Compiled by T. BENFLEY. 8vo. 52s. 6d.

**A Practical Dictionary of the French and English Languages.** By L. CONTANSEAU. 11th Edition, post 8vo. 10s. 6d.

**Contanseau's Pocket Dictionary,** French and English, abridged from the above by the Author. New Edition. 18mo. price 3s. 6d.

**New Practical Dictionary of the German Language; German-English, and English-German.** By the Rev. W. L. BLACKLEY, M.A., and Dr. CARL MARTIN FRIEDLÄNDER. Post 8vo. 14s.

*Miscellaneous Works and Popular Metaphysics.***Recreations of a Country Parson.**

By A. K. H. B. FIRST SERIES, with 41 Woodcut Illustrations from Designs by R. T. Pritchett. Crown 8vo. 12s. 6d.

**Recreations of a Country Parson. SECOND SERIES.** Crown 8vo. 8s. 6d.

**The Commonplace Philosopher in Town and Country.** By the same Author. Crown 8vo. 8s. 6d.

**Leisure Hours in Town; Essays Consolatory, Aesthetical, Moral, Social, and Domestic.** By the same. Crown 8vo. 8s. 6d.

**The Autumn Holidays of a Country Parson; Essays contributed to *Fraser's Magazine* and to *Good Words*.** By the same. Crown 8vo. 8s. 6d.

**The Graver Thoughts of a Country Parson, SECOND SERIES.** By the same. Crown 8vo. 8s. 6d.

**Original Essays of a Country Parson, selected from Essays contributed to *Fraser's Magazine*.** By the same. Post 8vo. 9s.

**Sunday Afternoons at the Parish Church of a University City.** By the same. Crown 8vo. 3s. 6d.

**A Campaigner at Home.** By SHIRLEY, Author of 'Thalatta' and 'Nugæ Criticæ.' Post 8vo. with Vignette, 7s. 6d.

**Studies in Parliament; a Series of Sketches of Leading Politicians.** By R. H. HURTON. (Reprinted from the *Pall Mall Gazette*.) Crown 8vo. 4s. 6d.

**Lord Macaulay's Miscellaneous Writings.**

LIBRARY EDITION, 2 vols. 8vo. Portrait, 21s.

PEOPLE'S EDITION, 1 vol. crown 8vo. 4s. 6d.

**The Rev. Sydney Smith's Miscellaneous Works; including his Contributions to the *Edinburgh Review*.** People's Edition, 2 vols. crown 8vo. 8s.

**Elementary Sketches of Moral Philosophy, delivered at the Royal Institution.** By the same Author. Fcp. 6s.

**The Wit and Wisdom of the Rev. SYDNEY SMITH; a Selection of the most memorable Passages in his Writings and Conversation.** 16mo. 5s.

**Epigrams, Ancient and Modern: Humorous, Witty, Satirical, Moral, and Panegyric.** Edited by Rev. JOHN BOOTH, B.A. Cambridge. Second Edition, revised and enlarged. Fcp. 7s. 6d.

**The Folk-Lore of the Northern Counties of England and the Borders.** By WILLIAM HENDERSON. With an Appendix on Household Stories by the Rev. S. BARING-GOULD. Crown 8vo. with Coloured Frontispiece, 9s. 6d.

**From Matter to Spirit: the Result of Ten Years' Experience in Spirit Manifestations.** By SOPHIA E. DE MORGAN. With a Preface by Professor DE MORGAN. Post 8vo. 8s. 6d.

**Essays selected from Contributions to the *Edinburgh Review*.** By HENRY ROGERS. Second Edition. 8 vols. fcp. 21s.

**Reason and Faith, their Claims and Conflicts.** By the same Author. New Edition, revised and extended, and accompanied by several other Essays, on related subjects. Crown 8vo. 6s. 6d.

**The Eclipse of Faith; or, a Visit to a Religious Sceptic.** By the same Author. Eleventh Edition. Fcp. 5s.

**Defence of the Eclipse of Faith, by its Author.** Third Edition. Fcp. 8s. 6d.

**Selections from the Correspondence of R. E. H. Greyson.** By the same Author. Third Edition. Crown 8vo. 7s. 6d.

**Fulleriana, or the Wisdom and Wit of THOMAS FULLER, with Essay on his Life and Genius.** By the same Author. 16mo. 2s. 6d.

**Occasional Essays.** By CHANDOS WREN HOSKYNs, Author of 'Talpa, or the Chronicles of a Clay Farm,' &c. 16mo. 5s. 6d.

**An Essay on Human Nature; showing the Necessity of a Divine Revelation for the Perfect Development of Man's Capacities.** By HENRY S. BOASE, M.D. F.R.S. and G.S. 8vo. 12s.

**The Philosophy of Nature; a Systematic Treatise on the Causes and Laws of Natural Phenomena.** By the same Author. 8vo. 12s.

**The Secret of Hegel: being the Hegelian System in Origin, Principle, Form, and Matter.** By JAMES HUTCHINSON STIRLING. 2 vols. 8vo. 28s.

**An Introduction to Mental Philosophy, on the Inductive Method.** By J. D. MORELL, M.A. LL.D. 8vo. 12s.

**Elements of Psychology, containing the Analysis of the Intellectual Powers.** By the same Author. Post 8vo. 7s. 6d.

**Sight and Touch:** an Attempt to Disprove the Received (or Berkeleyan) Theory of Vision. By THOMAS K. ABBOTT, M.A. Fellow and Tutor of Trin. Coll. Dublin. 8vo. with 21 Woodcuts, 5s. 6d.

**The Senses and the Intellect.** By ALEXANDER BAIN, M.A. Prof. of Logic in the Univ. of Aberdeen. Second Edition. 8vo. 15s.

**The Emotions and the Will,** by the same Author. 8vo. 15s.

**On the Study of Character,** including an Estimate of Phrenology. By the same Author. 8vo. 9s.

**Time and Space:** a Metaphysical Essay. By SHADWORTH H. HODGSON. 8vo. pp. 588, price 16s.

**The Way to Best:** Results from a Life-search after Religious Truth. By R. VAUGHAN, D.D. Crown 8vo. 7s. 6d.

**Hours with the Mystics:** a Contribution to the History of Religious Opinion. By ROBERT ALFRED VAUGHAN, B.A. Second Edition. 2 vols. crown 8vo. 12s.

**The Philosophy of Necessity;** or, Natural Law as applicable to Mental, Moral, and Social Science. By CHARLES BRAY. Second Edition. 8vo. 9s.

**The Education of the Feelings and Affections.** By the same Author. Third Edition. 8vo. 3s. 6d.

**On Force, its Mental and Moral Correlates.** By the same Author. 8vo. 5s.

**Christianity and Common Sense.** By Sir WILLOUGHBY JONES, Bart. M.A. Trin. Coll. Cantab. 8vo. 6s.

### *Astronomy, Meteorology, Popular Geography, &c.*

**Outlines of Astronomy.** By Sir J. F. W. HERSCHEL, Bart. M.A. Eighth Edition, revised; with Plates and Woodcuts. 8vo. 18s.

**Arago's Popular Astronomy.** Translated by Admiral W. H. SMYTH, F.R.S. and R. GRANT, M.A. With 25 Plates and 358 Woodcuts. 2 vols. 8vo. £2 5s.

**Saturn and its System.** By RICHARD A. PROCTOR, B.A. late Scholar of St. John's Coll. Camb. and King's Coll. London. 8vo. with 14 Plates, 14s.

**The Handbook of the Stars.** By the same Author. Square fcp. 8vo. with 3 Maps. price 5s.

**Celestial Objects for Common Telescopes.** By T. W. WEBB, M.A. F.R.A.S. With Map of the Moon, and Woodcuts. 16mo. 7s.

**A General Dictionary of Geography,** Descriptive, Physical, Statistical, and Historical; forming a complete Gazetteer of the World. By A. KEITH JOHNSTON, F.R.S.E. 8vo. 31s. 6d.

**M'Culloch's Dictionary, Geographical, Statistical, and Historical,** of the various Countries, Places, and principal Natural Objects in the World. Revised Edition, with the Statistical Information throughout brought up to the latest returns. By FREDERICK MARTIN. 4 vols. 8vo. with coloured Maps, £4 4s.

**A Manual of Geography, Physical, Industrial, and Political.** By W. HUGHES, F.R.G.S. Prof. of Geog. in King's Coll. and in Queen's Coll. Lond. With 6 Maps. Fcp. 7s. 6d.

**Hawaii:** the Past, Present, and Future of its Island-Kingdom: an Historical Account of the Sandwich Islands. By MANLEY HOPKINS, Hawaiian Consul-General, &c. Second Edition, revised and continued; with Portrait, Map, and 8 other Illustrations. Post 8vo. 12s. 6d.

**Maunder's Treasury of Geography,** Physical, Historical, Descriptive, and Political. Edited by W. HUGHES, F.R.G.S. With 7 Maps and 16 Plates. Fcp. 10s. 6d.

**Physical Geography for Schools** and General Readers. By M. F. MAURY, LL.D. Fcp. with 2 Charts, 2s. 6d.

### *Natural History and Popular Science.*

**The Elements of Physics** or Natural Philosophy. By NEIL ARNOTT, M.D. F.R.S. Physician Extraordinary to the Queen. Sixth Edition, rewritten and completed. 2 Parts, 8vo. 21s.

**Volcanos,** the Character of their Phenomena, their Share in the Structure and Composition of the Surface of the Globe, &c. By G. POULETT SCROPE, M.P. F.R.S. Second Edition. 8vo. with Illustrations, 15s.



**Rocks Classified and Described.**

By **BERNHARD VON COTTA**. An English Edition, by **P. H. LAWRENCE** (with English, German, and French Synonymes), revised by the Author. Post 8vo. 14s.

\* \* \* Lithology, or a Classified Synopsis of the Names of Rocks and Minerals, also by **MR. LAWRENCE**, adapted to the above work, may be had, price 5s. or printed on one side only (interpaged blank), for use in Cabinets, price 7s.

**Sound: a Course of Six Lectures** delivered at the Royal Institution of Great Britain. By Professor **JOHN TYNDALL**, LL.D. F.R.S. 1 vol. crown 8vo.  
[*Nearly ready.*]

**Heat Considered as a Mode of Motion.** By Professor **JOHN TYNDALL**, LL.D. F.R.S. Second Edition. Crown 8vo. with Woodcuts, 12s. 6d.

**A Treatise on Electricity, in Theory and Practice.** By **A. DE LA RIVE**, Prof. in the Academy of Geneva. Translated by **C. V. WALKER**, F.R.S. 8 vols. 8vo. with Woodcuts, £3 18s.

**The Correlation of Physical Forces.** By **W. R. GROVE**, Q.C. V.P.R.S. Fifth Edition, revised by the Author, and augmented by a Discourse on Continuity. 8vo.

**Manual of Geology.** By **S. HAUGHTON**, M.D. F.R.S. Fellow of Trin. Coll. and Prof. of Geol. in the Univ. of Dublin. Second Edition, with 66 Woodcuts. Fcp. 7s. 6d.

**A Guide to Geology.** By **J. PHILLIPS**, M.A. Prof. of Geol. in the Univ. of Oxford. Fifth Edition. Fcp. 4s.

**A Glossary of Mineralogy.** By **H. W. BRISTOW**, F.G.S. of the Geological Survey of Great Britain. With 486 Figures. Crown 8vo. 12s.

**The Elements: an Investigation of the Forces which determine the Position and Movements of the Ocean and Atmosphere.** By **WILLIAM LEIGHTON JORDAN**. VOL. I. royal 8vo. with 13 maps, price 8s.

**Phillips's Elementary Introduction to Mineralogy,** re-edited by **H. J. BROOKE**, F.R.S. and **W. H. MILLER**, F.G.S. Post 8vo. with Woodcuts, 18s.

**Van Der Hoeven's Handbook of Zoology.** Translated from the Second Dutch Edition by the Rev. **W. CLARK**, M.D. F.R.S. 2 vols. 8vo. with 24 Plates of Figures, 60s.

**The Comparative Anatomy and Physiology of the Vertebrate Animals.** By **RICHARD OWEN**, F.R.S. D.C.L. 8 vols. 8vo. with upwards of 1,200 Woodcuts. Vols. I. and II. price 21s. each, now ready. VOL. III. in the Spring.

**The First Man and His Place in Creation,** considered on the Principles of Common Sense from a Christian Point of View; with an Appendix on the Negro. By **GEORGE MOORE**, M.D. M.R.C.P.L. &c. Post 8vo. 8s. 6d.

**The Lake Dwellings of Switzerland and other Parts of Europe.** By **DR. F. KELLER**, President of the Antiquarian Association of Zurich. Translated and arranged by **J. E. LEE**, F.S.A. F.G.S. Author of 'Isca Silurum.' With several Woodcuts and nearly 100 Plates of Figures. Royal 8vo. 31s. 6d.

**Homes without Hands: a Description of the Habitations of Animals, classed according to their Principle of Construction.** By **REV. J. G. WOOD**, M.A. F.L.S. With about 140 Vignettes on Wood (20 full size of page). Second Edition. 8vo. 21s.

**The Harmonies of Nature and Unity of Creation.** By **DR. G. HARTWIG**, 8vo. with numerous Illustrations, 18s.

**The Sea and its Living Wonders.** By the same Author. Third Edition, enlarged. 8vo. with many Illustrations, 21s.

**The Tropical World.** By the same Author. With 8 Chromoxylographs and 172 Woodcuts. 8vo. 21s.

**Manual of Corals and Sea Jellies.** By **J. R. GREENE**, B.A. Edited by **J. A. GALBRAITH**, M.A. and **S. HAUGHTON**, M.D. Fcp. with 89 Woodcuts, 5s.

**Manual of Sponges and Animalculæ; with a General Introduction on the Principles of Zoology.** By the same Author and Editors. Fcp. with 16 Woodcuts, 2s.

**Manual of the Metalloids.** By **J. APJOHN**, M.D. F.R.S. and the same Editors. 2nd Edition. Fcp. with 88 Woodcuts, 7s. 6d.

**Sketches of the Natural History of Ceylon.** By **SIR J. EMERSON TENNENT**, K.C.S. LL.D. With 82 Wood Engravings. Post 8vo. 12s. 6d.

**Ceylon.** By the same Author. 5th Edition; with Maps, &c. and 90 Wood Engravings. 2 vols. 8vo. £2 10s.

**The Wild Elephant, its Structure and Habits,** with the Method of Taking and Training it in Ceylon. By the same Author. Fcp. 8vo. with Illustrations.

**A Familiar History of Birds.**

By E. STANLEY, D.D. late Lord Bishop of Norwich. Fcp. with Woodcuts, 8s. 6d.

**Kirby and Spence's Introduction to Entomology, or Elements of the Natural History of Insecta.** Crown 8vo. 5s.**Maunder's Treasury of Natural History, or Popular Dictionary of Zoology.** Revised and corrected by T. S. COBBOLD, M.D. Fcp. with 900 Woodcuts, 10s.**The Elements of Botany for Families and Schools.** Tenth Edition, revised by THOMAS MOORE, F.L.S. Fcp. with 154 Woodcuts, 2s. 6d.**The Treasury of Botany, or Popular Dictionary of the Vegetable Kingdom; with which is incorporated a Glossary of Botanical Terms.** Edited by J. LINDLEY, F.R.S. and T. MOORE, F.L.S. assisted by eminent Contributors. Pp. 1,274, with 274 Woodcuts and 20 Steel Plates. 2 Parts, fcp. 20s.**The British Flora; comprising the Phanogamous or Flowering Plants and the Ferns.** By Sir W. J. HOOKER, K.H. and G. A. WALKER-ARNOTT, LL.D. 12mo. with 12 Plates, 14s. or coloured, 21s.**The Rose Amateur's Guide.** By THOMAS RIVERS. New Edition. Fcp. 4s.**The Indoor Gardener.** By Miss MALING. Fcp. with Frontispiece, 5s.**Loudon's Encyclopædia of Plants; comprising the Specific Character, Description, Culture, History, &c. of all the Plants found in Great Britain.** With upwards of 12,000 Woodcuts. 8vo. 42s.**Loudon's Encyclopædia of Trees and Shrubs; containing the Hardy Trees and Shrubs of Great Britain scientifically and popularly described.** With 2,000 Woodcuts. 8vo. 50s.**Bryologia Britannica; containing the Mosses of Great Britain and Ireland, arranged and described.** By W. WILSON. 8vo. with 61 Plates, 42s. or coloured, £4 4s.**Maunder's Scientific and Literary Treasury; a Popular Encyclopædia of Science, Literature, and Art.** New Edition, thoroughly revised and in great part rewritten, with above 1,000 new articles, by J. Y. JOHNSON, Corr. M.Z.S. Fcp. 10s. 6d.**A Dictionary of Science, Literature, and Art.** Fourth Edition, re-edited by the late W. T. BRANDE (the Author) and GEORGE W. COX, M.A. 3 vols. medium 8vo. price 63s. cloth.**Essays on Scientific and other subjects, contributed to Reviews.** By Sir H. HOLLAND, Bart. M.D. Second Edition. 8vo. 14s.**Essays from the Edinburgh and Quarterly Reviews; with Addresses and other Pieces.** By Sir J. F. W. HERSCHEL, Bart. M.A. 8vo. 18s.*Chemistry, Medicine, Surgery, and the Allied Sciences.***A Dictionary of Chemistry and the Allied Branches of other Sciences.** By HENRY WATTS, F.C.S. assisted by eminent Contributors. 5 vols. medium 8vo. in course of publication in Parts. VOL. I. 81s. 6d. VOL. II. 26s. VOL. III. 31s. 6d. and VOL. IV. 24s. are now ready.**A Handbook of Volumetrical Analysis.** By ROBERT H. SCOTT, M.A. T.C.D. Post 8vo. 4s. 6d.**Elements of Chemistry, Theoretical and Practical.** By WILLIAM A. MILLER, M.D. LL.D. F.R.S. F.G.S. Professor of Chemistry, King's College, London. 3 vols. 8vo. £2 13s. PART I. CHEMICAL PHYSICS, Third Edition, 12s. PART II. INORGANIC CHEMISTRY, 21s. PART III. ORGANIC CHEMISTRY, Third Edition, 24s.**A Manual of Chemistry, Descriptive and Theoretical.** By WILLIAM ODLING, M.B. F.R.S. PART I. 8vo. 9s.**A Course of Practical Chemistry, for the use of Medical Students.** By the same Author. Second Edition, with 70 new Woodcuts. Crown 8vo. 7s. 6d.**Lectures on Animal Chemistry Delivered at the Royal College of Physicians in 1865.** By the same Author. Crown 8vo. 4s. 6d.**The Toxicologist's Guide: a New Manual on Poisons, giving the Best Methods to be pursued for the Detection of Poisons.** By J. HORSLEY, F.C.S. Analytical Chemist. Post 8vo. 8s. 6d.

**The Diagnosis and Treatment of the Diseases of Women;** including the Diagnosis of Pregnancy. By GRAILY HERRI, M.D. &c. New Edition, with Woodcut Illustrations, in the press.

**Lectures on the Diseases of Infancy and Childhood.** By CHARLES WEST, M.D. &c. 5th Edition, revised and enlarged. 8vo. 16s.

**Exposition of the Signs and Symptoms of Pregnancy:** with other Papers on subjects connected with Midwifery. By W. F. MONTGOMERY, M.A. M.D. M.R.I.A. 8vo. with Illustrations, 25s.

**A System of Surgery, Theoretical and Practical,** in Treatises by Various Authors. Edited by T. HOLMES, M.A. Cantab. Assistant-Surgeon to St. George's Hospital. 4 vols. 8vo. £4 18s.

**Vol. I. General Pathology, &c.**

**Vol. II. Local Injuries:** Gun-shot Wounds, Injuries of the Head, Back, Face, Neck, Chest, Abdomen, Pelvis, of the Upper and Lower Extremities, and Diseases of the Eye. 21s.

**Vol. III. Operative Surgery.** Diseases of the Organs of Circulation, Locomotion, &c. 21s.

**Vol. IV. Diseases of the Organs of Digestion,** of the Genito-Urinary System, and of the Breast, Thyroid Gland, and Skin; with APPENDIX and GENERAL INDEX. 30s.

**Lectures on the Principles and Practice of Physic.** By THOMAS WATSON, M.D. Physician-Extraordinary to the Queen. Fourth Edition. 2 vols. 8vo. 34s.

**Lectures on Surgical Pathology.** By J. PAGER, F.R.S. Surgeon-Extraordinary to the Queen. Edited by W. TURNER, M.B. 8vo. with 117 Woodcuts, 21s.

**A Treatise on the Continued Fevers of Great Britain.** By C. MURCHISON, M.D. Senior Physician to the London Fever Hospital. 8vo. with coloured Plates, 18s.

**Anatomy, Descriptive and Surgical.** By HENRY GRAY, F.R.S. With 410 Wood Engravings from Dissections. Fourth Edition, by T. HOLMES, M.A. Cantab. Royal 8vo. 28s.

**The Cyclopædia of Anatomy and Physiology.** Edited by the late R. B. TODD, M.D. F.R.S. Assisted by nearly all the most eminent cultivators of Physiological Science of the present age. 5 vols. 8vo. with 2,853 Woodcuts, £6 6s.

**Physiological Anatomy and Physiology of Man.** By the late R. B. TODD, M.D. F.R.S. and W. BOWMAN, F.R.S. of King's College. With numerous Illustrations. VOL. II. 8vo. 25s.

VOL. I. New Edition by Dr. LIONEL S. BRALE, F.R.S. in course of publication; PART I. with 8 Plates, 7s. 6d.

**Histological Demonstrations;** a Guide to the Microscopical Examination of the Animal Tissues in Health and Disease, for the use of the Medical and Veterinary Professions. By G. HARLEY, M.D. F.R.S. Prof. in Univ. Coll. London; and G. T. BROWN, M.R.C.V.S. Professor of Veterinary Medicine, and one of the Inspecting Officers in the Cattle Plague Department of the Privy Council. Post 8vo. with 223 Woodcuts, 12s.

**A Dictionary of Practical Medicine.** By J. COPLAND, M.D. F.R.S. Abridged from the larger work by the Author, assisted by J. C. COPLAND, M.R.C.S. and throughout brought down to the present state of Medical Science. Pp. 1,560, in 8vo. price 86s.

**The Works of Sir B. C. Brodie,** Bart. collected and arranged by CHARLES HAWKINS, F.R.C.S.E. 3 vols. 8vo. with Medallion and Facsimile, 48s.

**Autobiography of Sir B. C. Brodie,** Bart. printed from the Author's materials left in MS. Second Edition. Fcp. 4s. 6d.

**A Manual of Materia Medica and Therapeutics,** abridged from Dr. PERRIRA's *Elements* by F. J. FARRE, M.D. assisted by R. BENTLEY, M.R.C.S. and by R. WARINGTON, F.R.S. 1 vol. 8vo. with 90 Woodcuts, 21s.

**Dr. Pereira's Elements of Materia Medica and Therapeutics,** Third Edition, by A. S. TAYLOR, M.D. and G. O. REES, M.D. 8 vols. 8vo. with Woodcuts, £3 15s.

**Thomson's Conspectus of the British Pharmacopœia.** Twenty-fourth Edition, corrected and made conformable throughout to the New Pharmacopœia of the General Council of Medical Education. By E. LLOYD BIRKETT, M.D. 18mo. 5s. 6d.

**Manual of the Domestic Practice of Medicine.** By W. B. KRSTEVAN, F.R.C.S.E. Second Edition, thoroughly revised, with Additions. Fcp. 5s.

**Sea-Air and Sea-Bathing for Children and Invalids.** By WILLIAM STRANGE, M.D. Fcp. 3s.

**The Restoration of Health;** or, the Application of the Laws of Hygiene to the Recovery of Health: a Manual for the Invalid, and a Guide in the Sick Room. By W. STRANGE, M.D. Fcp. 6s.

**Manual for the Classification,** Training, and Education of the Feeble-Minded, Imbecile, and Idiotic. By P. MARTIN DUNCAN, M.B. and WILLIAM MILLARD. Crown 8vo. 5s.]

### *The Fine Arts, and Illustrated Editions.*

**The Life of Man Symbolised** by the Months of the Year in their Seasons and Phases; with Passages selected from Ancient and Modern Authors. By RICHARD FIGOT. Accompanied by a Series of 25 full-page Illustrations and numerous Marginal Devices, Decorative Initial Letters, and Tailpieces, engraved on Wood from Original Designs by JOHN LEIGHTON, F.S.A. 4to. 42s.

**The New Testament,** illustrated with Wood Engravings after the Early Masters, chiefly of the Italian School. Crown 4to. 68s. cloth, gilt top; or £5 5s. morocco.

**Lyra Germanica;** Hymns for the Sundays and Chief Festivals of the Christian Year. Translated by CATHERINE WINKWORTH; 125 Illustrations on Wood drawn by J. LEIGHTON, F.S.A. Fcp. 4to 21s.

**Cats' and Farlie's Moral Emblems;** with Aphorisms, Adages, and Proverbs of all Nations: comprising 121 Illustrations on Wood by J. LEIGHTON, F.S.A. with an appropriate Text by R. FIGOT. Imperial 8vo. 31s. 6d.

**Shakspeare's Sentiments and Similes** printed in Black and Gold, and illuminated in the Missal style by HENRY NOEL HUMPHREYS. In massive covers, containing the Medallion and Cypher of Shakspeare. Square post 8vo. 21s.

**Half-Hour Lectures on the History and Practice of the Fine and Ornamental Arts.** By W. B. SCOTT. Second Edition. Crown 8vo. with 50 Woodcut Illustrations, 8s. 6d.

**The History of Our Lord,** as exemplified in Works of Art. By Mrs. JAMESON and Lady EASTLAKE. Being the concluding Series of 'Sacred and Legendary Art.' Second Edition, with 13 Etchings and 281 Woodcuts. 2 vols. square crown 8vo. 42s.

**Mrs. Jameson's Legends of the Saints and Martyrs.** Fourth Edition, with 19 Etchings and 187 Woodcuts. 2 vols. 81s. 6d.

**Mrs. Jameson's Legends of the Monastic Orders.** Third Edition, with 11 Etchings and 88 Woodcuts. 1 vol. 21s.

**Mrs. Jameson's Legends of the Madonna.** Third Edition, with 27 Etchings and 165 Woodcuts. 1 vol. 21s.

### *Musical Publications.*

**An Introduction to the Study of National Music;** Comprising Researches into Popular Songs, Traditions, and Customs. By CARL ENGEL, Author of 'The Music of the most Ancient Nations.' With Frontispiece and numerous Musical Illustrations. 8vo. 16s.

**Six Lectures on Harmony.** Delivered at the Royal Institution of Great Britain before Easter 1867. By G. A. MACFARREN. 8vo. [In the press.]

**Lectures on the History of Modern Music,** delivered at the Royal Institution. By JOHN HULLAH. FIRST COURSE, with Chronological Tables, post 8vo. 6s. 6d. SECOND COURSE, the Transition Period, with 26 Specimens, 8vo. 16s.

**Sacred Music for Family Use;** A Selection of Pieces for One, Two, or more Voices, from the best Composers, Foreign and English. Edited by JOHN HULLAH. 1 vol. music folio, 21s. half bound.

**Hullah's Part Music, Sacred and Secular,** for Soprano, Alto, Tenor, and Bass. New Edition, with Pianoforte Accompaniments, in course of publication in Monthly Numbers, each number in Score, with Pianoforte Accompaniment, price 1s. and in separate Parts (Soprano, Alto, Tenor, and Bass), uniform with the Score in size, but in larger type, price 3d. each Part. Each Series (Sacred and Secular) to be completed in 12 Numbers, forming a Volume, in imperial 8vo.

*Arts, Manufactures, &c.*

**Drawing from Nature; a Series of Progressive Instructions in Sketching, from Elementary Studies to Finished Views, with Examples from Switzerland and the Pyrenees.** By GEORGE BARNARD, Professor of Drawing at Rugby School. With 18 Lithographic Plates and 108 Wood Engravings. Imp. 8vo. 25s.

**Gwilt's Encyclopædia of Architecture.** New Edition, revised, with alterations and considerable Additions, by WYATT PAPWORTH. With above 350 New Engravings and Diagrams on Wood by O. JEWITT, and upwards of 100 other Woodcuts. 8vo. [Nearly ready.]

**Tuscan Sculptors, their Lives, Works, and Times.** With 45 Etchings and 28 Woodcuts from Original Drawings and Photographs. By CHARLES C. PERKINS. 2 vols. imp. 8vo. 68s.

**The Grammar of Heraldry:** containing a Description of all the Principal Charges used in Armory, the Signification of Heraldic Terms, and the Rules to be observed in Blazoning and Marshalling. By JOHN E. CUSSANS. Fcp. with 196 Woodcuts, 4s. 6d.

**The Engineer's Handbook;** explaining the Principles which should guide the young Engineer in the Construction of Machinery. By C. S. LOWNDER. Post 8vo. 5s.

**The Elements of Mechanism.** By T. M. GOODEVE, M.A. Prof. of Mechanics at the R. M. Acad. Woolwich. Second Edition, with 217 Woodcuts. Post 8vo. 6s. 6d.

**Ure's Dictionary of Arts, Manufactures, and Mines.** Re-written and enlarged by ROBERT HUNT, F.R.S., assisted by numerous Contributors eminent in Science and the Arts. With 2,000 Woodcuts. 3 vols. 8vo. [Nearly ready.]

**Treatise on Mills and Millwork.** By W. FAIRBAIRN, C.E. F.R.S. With 18 Plates and 822 Woodcuts. 2 vols. 8vo. 82s.

**Useful Information for Engineers.** By the same Author. FIRST, SECOND, and THIRD SERIES, with many Plates and Woodcuts. 3 vols. crown 8vo. 10s. 6d. each.

**The Application of Cast and Wrought Iron to Building Purposes.** By the same Author. Third Edition, with 6 Plates and 118 Woodcuts. 8vo. 16s.

**Iron Ship Building, its History and Progress,** as comprised in a Series of Experimental Researches on the Laws of Strain; the Strengths, Forms, and other conditions of the Material; and an Inquiry into the Present and Prospective State of the Navy, including the Experimental Results on the Resisting Powers of Armour Plates and Shot at High Velocities. By W. FAIRBAIRN, C.E. F.R.S. With 4 Plates and 180 Woodcuts, 8vo. 18s.

**Encyclopædia of Civil Engineering, Historical, Theoretical, and Practical.** By E. CRESSY, C.E. With above 3,000 Woodcuts. 8vo. 42s.

**The Practical Mechanic's Journal:** An Illustrated Record of Mechanical and Engineering Science, and Epitome of Patent Inventions. 4to. price 1s. monthly.

**The Practical Draughtsman's Book of Industrial Design.** By W. JOHNSON, Assoc. Inst. C.E. With many hundred Illustrations. 4to. 28s. 6d.

**The Patentee's Manual: a Treatise on the Law and Practice of Letters Patent for the use of Patentees and Inventors.** By J. and J. H. JOHNSON. Post 8vo. 7s. 6d.

**The Artisan Club's Treatise on the Steam Engine, in its various Applications to Mines, Mills, Steam Navigation, Railways, and Agriculture.** By J. BOURNE, C.E. Seventh Edition; with 37 Plates and 546 Woodcuts. 4to. 42s.

**A Treatise on the Screw Propeller, Screw Vessels, and Screw Engines,** as adapted for purposes of Peace and War; illustrated by many Plates and Woodcuts. By the same Author. New and enlarged Edition in course of publication in 24 Parts, royal 4to. 2s. 6d. each.

**Catechism of the Steam Engine,** in its various Applications to Mines, Mills, Steam Navigation, Railways, and Agriculture. By J. BOURNE, C.E. With 199 Woodcuts. Fcp. 9s. The INTRODUCTION of 'Recent Improvements' may be had separately, with 110 Woodcuts, price 3s. 6d.

**Handbook of the Steam Engine,** by the same Author, forming a KEY to the Catechism of the Steam Engine, with 67 Woodcuts. Fcp. 9s.

**The Art of Perfumery ; the History and Theory of Odours, and the Methods of Extracting the Aromas of Plants.** By Dr. PIESSE, F.C.S. Third Edition, with 58 Woodcuts. Crown 8vo. 10s. 6d.

**Chemical, Natural, and Physical Magic, for Juveniles during the Holidays.** By the same Author. Third Edition, enlarged with 88 Woodcuts. Fcp. 6s.

**Talpa ; or, the Chronicles of a Clay Farm.** By C. W. HOSKYNs, Esq. With 24 Woodcuts from Designs by G. CRUIK-SHANK. Sixth Edition. 16mo. 5s. 6d.

**History of Windsor Great Park and Windsor Forest.** By WILLIAM MENZIES, Resident Deputy Surveyor. With 2 Maps and 20 Photographs. Imp. folio, £8 8s.

**Loudon's Encyclopædia of Agriculture :** Comprising the Laying-out, Improvement, and Management of Landed Property, and the Cultivation and Economy of the Productions of Agriculture. With 1,100 Woodcuts. 8vo. 81s. 6d.

**Loudon's Encyclopædia of Gardening :** Comprising the Theory and Practice of Horticulture, Floriculture, Arboriculture, and Landscape Gardening. With 1,000 Woodcuts. 8vo. 81s. 6d.

**Loudon's Encyclopædia of Cottage, Farm, and Villa Architecture and Furniture.** With more than 2,000 Woodcuts. 8vo. 42s.

**Bayldon's Art of Valuing Rents and Tillages, and Claims of Tenants upon Quitting Farms, both at Michaelmas and Lady-Day.** Eighth Edition, revised by J. C. MORTON. 8vo. 10s. 6d.

### *Religious and Moral Works.*

**An Exposition of the 39 Articles, Historical and Doctrinal.** By E. HAROLD BROWNE, D.D. Lord Bishop of Ely. Seventh Edition. 8vo. 16s.

**The Pentateuch and the Elohistio Psalms, in Reply to Bishop Colenso.** By the same. Second Edition. 8vo. 2s.

**Examination-Questions on Bishop Browne's Exposition of the Articles.** By the Rev. J. GORLE, M.A. Fcp. 3s. 6d.

**The Acts of the Apostles ; with a Commentary, and Practical and Devotional Suggestions for Readers and Students of the English Bible.** By the Rev. F. C. COOK, M.A., Canon of Exeter, &c. New Edition, 8vo. 12s. 6d.

**The Life and Epistles of St. Paul.** By W. J. CONYBEARE, M.A. late Fellow of Trin. Coll. Cantab. and J. S. HOWSON, D.D. Principal of Liverpool Coll.

LIBRARY EDITION, with all the Original Illustrations, Maps, Landscapes on Steel, Woodcuts, &c. 2 vols. 4to. 48s.

INTERMEDIATE EDITION, with a Selection of Maps, Plates, and Woodcuts. 2 vols. square crown 8vo. 31s. 6d.

PEOPLE'S EDITION, revised and condensed, with 46 Illustrations and Maps. 2 vols. crown 8vo. 12s.

**The Voyage and Shipwreck of St. Paul ; with Dissertations on the Ships and Navigation of the Ancients.** By JAMES SMITH, F.R.S. Crown 8vo. Charts, 10s. 6d.

**Fasti Sacri, or a Key to the Chronology of the New Testament ; comprising an Historical Harmony of the Four Gospels, and Chronological Tables generally from B.C. 70 to A.D. 70 : with a Preliminary Dissertation and other Aids.** By THOMAS LEWIN, M.A. F.S.A. Imp. 8vo. 42s.

**A Critical and Grammatical Commentary on St. Paul's Epistles.** By C. J. ELLICOTT, D.D. Lord Bishop of Gloucester and Bristol. 8vo.

Galatians, Third Edition, 8s. 6d.

Ephesians, Third Edition, 8s. 6d.

Pastoral Epistles, Third Edition, 10s. 6d.

Philippians, Colossians, and Philemon, Third Edition, 10s. 6d.

Thessalonians, Second Edition, 7s. 6d.

**Historical Lectures on the Life of Our Lord Jesus Christ : being the Hulsean Lectures for 1859.** By the same Author. Fourth Edition. 8vo. 10s. 6d.

**The Destiny of the Creature ; and other Sermons preached before the University of Cambridge.** By the same. Post 8vo. 5s.

**The Broad and the Narrow Way ; Two Sermons preached before the University of Cambridge.** By the same. Crown 8vo. 2s.

**The Greek Testament ; with Notes, Grammatical and Exegetical.** By the Rev. W. WEBSTER, M.A. and the Rev. W. F. WILKINSON, M.A. 2 vols. 8vo. £2 4s.

VOL. I. the Gospels and Acts, 20s.

VOL. II. the Epistles and Apocalypse, 24s.

- Rev. T. H. Horne's Introduction** to the Critical Study and Knowledge of the Holy Scriptures. Eleventh Edition, corrected, and extended under careful Editorial revision. With 4 Maps and 22 Woodcuts and Facsimiles. 4 vols. 8vo. £3 13s. 6d.
- Rev. T. H. Horne's Compendious Introduction** to the Study of the Bible, being an Analysis of the larger work by the same Author. Re-edited by the Rev. JOHN AYRE, M.A. With Maps, &c. Post 8vo. 9s.
- The Treasury of Bible Knowledge;** being a Dictionary of the Books, Persons, Places, Events, and other Matters of which mention is made in Holy Scripture; intended to establish its Authority and illustrate its Contents. By Rev. J. AYRE, M.A. With Maps, 15 Plates, and numerous Woodcuts. Fcp. 10s. 6d.
- Every-day Scripture Difficulties** explained and illustrated. By J. E. PRESCOTT, M.A. VOL. I. *Matthew* and *Mark*; VOL. II. *Luke* and *John*. 2 vols. 8vo. 9s. each.
- The Pentateuch and Book of Joshua** Critically Examined. By the Right Rev. J. W. COLENSO, D.D. Lord Bishop of Natal. People's Edition, in 1 vol. crown 8vo. 6s. or in 5 Parts, 1s. each.
- The Pentateuch and Book of Joshua** Critically Examined. By Prof. A. KUENEN, of Leyden. Translated from the Dutch, and edited with Notes, by the Right Rev. J. W. COLENSO, D.D. Bishop of Natal. 8vo. 8s. 6d.
- The Church and the World: Essays** on Questions of the Day. By various Writers. Edited by Rev. ORBY SHIPLEY, M.A. Second Edition, revised. 8vo. 15s.
- The Formation of Christendom.** PART I. By T. W. ALLIES. 8vo. 12s.
- Christendom's Divisions; a Philosophical Sketch** of the Divisions of the Christian Family in East and West. By EDMUND S. FROULKES, formerly Fellow and Tutor of Jesus Coll. Oxford. Post 8vo. 7s. 6d.
- Christendom's Divisions, Part II.** *Greeks and Latins*, being a History of their Dissentions and Overtures for Peace down to the Reformation. By the same Author. [*Nearly ready.*]
- The Life of Christ,** an Eclectic Gospel, from the Old and New Testaments, arranged on a New Principle, with Analytical Tables, &c. By CHARLES DE LA PRYNE, M.A. Revised Edition. 8vo. 5s.
- The Hidden Wisdom of Christ** and the Key of Knowledge; or, History of the Apocrypha. By ERNEST DE BUNSEN. 2 vols. 8vo. 28s.
- The Temporal Mission of the Holy Ghost;** or, Reason and Revelation. By the Most Rev. Archbishop MANNING. Second Edition. Crown 8vo. 8s. 6d.
- Essays on Religion and Literature.** Edited by the Most Rev. Archbishop MANNING. 8vo. 10s. 6d.
- Essays and Reviews.** By the Rev. W. TEMPLE, D.D. the Rev. R. WILLIAMS, B.D. the Rev. B. POWELL, M.A. the Rev. H. B. WILSON, B.D. C. W. GOODWIN, M.A. the Rev. M. PATTISON, B.D. and the Rev. B. JOWETT, M.A. 12th Edition. Fcp. 5s.
- Mosheim's Ecclesiastical History.** MURDOCK and SOAMER'S Translation and Notes, re-edited by the Rev. W. STUBBS, M.A. 8 vols. 8vo. 45s.
- Bishop Jeremy Taylor's Entire Works:** With Life by BISHOP HEBER. Revised and corrected by the Rev. C. P. EDEN, 10 vols. £5 5s.
- Passing Thoughts on Religion.** By the Author of 'Amy Herbart.' New Edition. Fcp. 5s.
- Thoughts for the Holy Week,** for Young Persons. By the same Author. Third Edition. Fcp. 8vo. 2s.
- Self-examination before Confirmation.** By the same Author. 32mo. 1s. 6d.
- Readings for a Month Preparatory to Confirmation** from Writers of the Early and English Church. By the same. Fcp. 4s.
- Readings for Every Day in Lent,** compiled from the Writings of Bishop JEREMY TAYLOR. By the same. Fcp. 5s.
- Preparation for the Holy Communion;** the Devotions chiefly from the works of JEREMY TAYLOR. By the same. 32mo. 3s.
- Principles of Education** drawn from Nature and Revelation, and Applied to Female Education in the Upper Classes. By the same. 2 vols. fcp. 12s. 6d.
- The Wife's Manual;** or, Prayers, Thoughts, and Songs on Several Occasions of a Matron's Life. By the Rev. W. CALVERT, M.A. Crown 8vo. 10s. 6d.
- Lyra Domestica; Christian Songs** for Domestic Edification. Translated from the *Psaltery and Harp* of C. J. P. SPITTA, and from other sources, by RICHARD MASSEY. FIRST and SECOND SERIES, fcp. 4s. 6d. each.

**Spiritual Songs for the Sundays and Holidays throughout the Year.** By J. S. B. MONSELL, LL.D. Vicar of Egham. Fourth Edition. Fcp. 4s. 6d.

**The Beatitudes:** Abasement before God; Sorrow for Sin; Meekness of Spirit; Desire for Holiness; Gentleness; Purity of Heart; the Peace-makers; Sufferings for Christ. By the same. Third Edition. Fcp. 8s. 6d.

**Lyra Sacra;** Hymns, Ancient and Modern, Odes, and Fragments of Sacred Poetry. Edited by the Rev. B. W. SAVILE, M.A. Third Edition, enlarged. Fcp. 5s.

**Lyra Germanica,** translated from the German by Miss C. WINKWORTH. FIRST SERIES, Hymns for the Sundays and Chief Festivals; SECOND SERIES, the Christian Life. Fcp. 3s. 6d. each SERIES.

Hymns from *Lyra Germanica*, 18mo. 1s.

**The Chorale Book for England;** a complete Hymn-Book in accordance with the Services and Festivals of the Church of England; the Hymns translated by Miss C. WINKWORTH; the Tunes arranged by Prof. W. S. BENNETT and OTTO GOLDSCHMIDT. Fcp. 4to. 12s. 6d.

Congregational Edition. Fcp. 2s.

**Lyra Eucharistica;** Hymns and Verses on the Holy Communion, Ancient and Modern; with other Poems. Edited by the Rev. ORBY SHIPLEY, M.A. Second Edition. Fcp. 7s. 6d.

**Lyra Messianica;** Hymns and Verses on the Life of Christ, Ancient and Modern; with other Poems. By the same Editor. Second Edition, enlarged. Fcp. 7s. 6d.

**Lyra Mystica;** Hymns and Verses on Sacred Subjects, Ancient and Modern. By the same Editor. Fcp. 7s. 6d.

**The Catholic Doctrine of the Atonement;** an Historical Inquiry into its Development in the Church; with an Introduction on the Principle of Theological Developments. By H. N. OXENHAM, M.A. formerly Scholar of Balliol College, Oxford. 8vo. 8s. 6d.

**From Sunday to Sunday;** an Attempt to consider familiarly the Weekday Life and Labours of a Country Clergyman. By R. GEE, M.A. Fcp. 6s.

**Our Sermons:** an Attempt to consider familiarly, but reverently, the Preacher's Work in the present day. By the same Author. Fcp. 6s.

**Paley's Moral Philosophy,** with Annotations. By RICHARD WHATLEY, D.D. late Archbishop of Dublin. 8vo. 7s.

### *Travels, Voyages, &c.*

**Ice Caves of France and Switzerland;** a narrative of Subterranean Exploration. By the Rev. G. F. BROWNE, M.A. Fellow and Assistant-Tutor of St. Catherine's Coll. Cambridge, M.A.C. With 11 Woodcuts. Square crown 8vo. 12s. 6d.

**Village Life in Switzerland.** By SOPHIA D. DELMARD. Post 8vo. 9s. 6d.

**How we Spent the Summer;** or, a Voyage en Zigzag in Switzerland and Tyrol with some Members of the ALPINE CLUB. From the Sketch-Book of one of the Party. Third Edition, re-drawn. In oblong 4to. with about 300 Illustrations, 15s.

**Beaten Tracks;** or, Pen and Pencil Sketches in Italy. By the Authoress of 'A Voyage en Zigzag.' With 42 Plates, containing about 200 Sketches from Drawings made on the Spot. 8vo. 16s.

**Map of the Chain of Mont Blanc,** from an actual Survey in 1863—1864. By A. ADAMS-REILLY, F.R.G.S. M.A.C. Published under the Authority of the Alpine Club. In Chromolithography on extra stout drawing-paper 28in. x 17in. price 10s. or mounted on canvas in a folding case, 12s. 6d.

**Transylvania, its Products and its People.** By CHARLES BONER. With 5 Maps and 43 Illustrations on Wood and in Chromolithography. 8vo. 21s.

**Explorations in South-west Africa,** from Walvisch Bay to Lake Ngami and the Victoria Falls. By THOMAS BAINES, F.R.G.S. 8vo. with Maps and Illustrations, 21s.

**Vancouver Island and British Columbia;** their History, Resources, and Prospects. By MATTHEW MACFIE, F.R.G.S. With Maps and Illustrations. 8vo. 18s.



**History of Discovery in our Australasian Colonies, Australia, Tasmania, and New Zealand, from the Earliest Date to the Present Day.** By WILLIAM HOWITT. With 3 Maps of the Recent Explorations from Official Sources. 2 vols. 8vo. 20s.

**The Capital of the Tycoon; a Narrative of a 3 Years' Residence in Japan.** By Sir RUTHERFORD ALCOCK, K.C.B. 2 vols. 8vo. with numerous Illustrations, 42s.

**Florence, the New Capital of Italy.** By C. R. WELD. With several Engravings on Wood, from Drawings by the Author. Post 8vo.

**The Dolomite Mountains.** Excursions through Tyrol, Carinthia, Carniola, and Friuli in 1861, 1862, and 1863. By J. GILBERT and G. C. CHURCHILL, F.R.G.S. With numerous Illustrations. Square crown 8vo. 21s.

**A Lady's Tour Round Monte Rosa; including Visits to the Italian Valleys.** With Map and Illustrations. Post 8vo. 14s.

**Guide to the Pyrenees, for the use of Mountaineers.** By CHARLES PACKE. With Maps, &c. and Appendix. Fcp. 6s.

**A Guide to Spain.** By H. O'SHEA. Post 8vo. with Travelling Map, 15s.

**Christopher Columbus; his Life, Voyages, and Discoveries.** Revised Edition, with 4 Woodcuts. 18mo. 2s. 6d.

**Captain James Cook; his Life, Voyages, and Discoveries.** Revised Edition, with numerous Woodcuts. 18mo. 2s. 6d.

**The Alpine Guide.** By JOHN BALL, M.R.I.A. late President of the Alpine Club. Post 8vo. with Maps and other Illustrations.

**Guide to the Eastern Alps.** [Just ready.

**Guide to the Western Alps, including Mont Blanc, Monte Rosa, Zermatt, &c.** price 7s. 6d.

**Guide to the Oberland and all Switzerland, excepting the Neighbourhood of Monte Rosa and the Great St. Bernard; with Lombardy and the adjoining portion of Tyrol.** 7s. 6d.

**Humboldt's Travels and Discoveries in South America.** Third Edition, with numerous Woodcuts. 18mo. 2s. 6d.

**Narratives of Shipwrecks of the Royal Navy between 1793 and 1857, compiled from Official Documents in the Admiralty by W. O. S. GILLY; with a Preface by W. S. GILLY, D.D.** 3d Edition, fcp. 5s.

**A Week at the Land's End.** By J. T. BLIGHT; assisted by E. H. RODD, R. Q. COUCH, and J. RALFS. With Map and 96 Woodcuts. Fcp. 6s. 6d.

**Visits to Remarkable Places: Old Halls, Battle-Fields, and Scenes illustrative of Striking Passages in English History and Poetry.** By WILLIAM HOWITT. 2 vols. square crown 8vo. with Wood Engravings, 25s.

**The Rural Life of England.** By the same Author. With Woodcuts by Bewick and Williams. Medium 8vo. 12s. 6d.

### Works of Fiction.

**Atherstone Priory.** By L. N. COMYN. 2 vols. post 8vo. 21s.

**Ellice: a Tale.** By the same. Post 8vo. 9s. 6d.

**Stories and Tales by the Author of 'Amy Herbert,'** uniform Edition, each Tale or Story complete in a single volume.

AMY HERBERT, 2s. 6d.	KATHARINE ASHTON, 8s. 6d.
GERTRUDE, 2s. 6d.	MARGARET PERCIVAL, 5s.
EARL'S DAUGHTER, 2s. 6d.	LANETON PARSONAGE, 4s. 6d.
EXPERIENCE OF LIFE, 2s. 6d.	URSULA, 4s. 6d.
CLEVE HALL, 3s. 6d.	
IVORS, 3s. 6d.	

**A Glimpse of the World.** By the Author of 'Amy Herbert.' Fcp. 7s. 6d.

**The Six Sisters of the Valleys: an Historical Romance.** By W. BRAMLEY-MOORE, M.A. Incumbent of Gerrard's Cross, Bucks. Fourth Edition, with 14 Illustrations. Crown 8vo. 5s.

**Gallus; or, Roman Scenes of the Time of Augustus; with Notes and Excursuses illustrative of the Manners and Customs of the Ancient Romans.** From the German of Prof. BECKER. New Edit. Post 8vo. 7s. 6d.

**Charicles; a Tale illustrative of Private Life among the Ancient Greeks: with Notes and Excursuses.** From the German of Prof. BECKER. New Edition, Post 8vo. 7s. 6d.

- Icelandic Legends.** Collected by JON. ARNASON. Selected and Translated from the Icelandic by GEORGE E. J. POWELL and E. MAGNUSSON. SECOND SERIES, with Notes and an Introductory Essay on the Origin and Genius of the Icelandic Folk-Lore, and 8 Illustrations on Wood. Crown 8vo. 21s.
- The Warden : a Novel.** By ANTHONY TROLLOPE, Crown 8vo. 2s. 6d.
- Barchester Towers : a Sequel to 'The Warden.'** By the same Author. Crown 8vo. 3s. 6d.
- Tales from Greek Mythology.** By GEORGE W. COX, M.A. late Scholar of Trin. Coll. Oxon. Second Edition. Square 16mo. 3s. 6d.
- Tales of the Gods and Heroes.** By the same Author. Second Edition. Fcp. 5s.
- Tales of Thebes and Argos.** By the same Author. Fcp. 4s. 6d.
- The Gladiators : a Tale of Rome and Judæa.** By G. J. WHYTE MELVILLE. Crown 8vo. 5s.
- Digby Grand, an Autobiography.** By the same Author. 1 vol. 5s.
- Kate Coventry, an Autobiography.** By the same. 1 vol. 6s.
- General Bounce, or the Lady and the Locusts.** By the same. 1 vol. 5s.
- Holmby House, a Tale of Old Northamptonshire.** 1 vol. 5s.
- Good for Nothing, or All Down Hill.** By the same. 1 vol. 6s.
- The Queen's Maries, a Romance of Holyrood.** By the same. 1 vol. 6s.
- The Interpreter, a Tale of the War.** By the same Author. 1 vol. 5s.

### Poetry and The Drama.

- Goethe's Second Faust.** Translated by JOHN ANSTER, LL.D. M.R.I.A. Regius Professor of Civil Law in the University of Dublin. Post 8vo. 15s.
- Tasso's Jerusalem Delivered,** translated into English Verse by Sir J. KINGSTON JAMES, Kt. M.A. 2 vols. fcp. with Facsimile, 14s.
- Poetical Works of John Edmund Reade;** with final Revision and Additions. 3 vols. fcp. 18s. or each vol. separately, 6s.
- Moore's Poetical Works,** Cheapest Editions complete in 1 vol. including the Autobiographical Prefaces and Author's last Notes, which are still copyright. Crown 8vo. ruby type, with Portrait, 6s. or People's Edition, in larger type, 12s. 6d.
- Moore's Poetical Works,** as above, Library Edition, medium 8vo. with Portrait and Vignette, 14s. or in 10 vols. fcp. 3s. 6d. each.
- Moore's Lalla Rookh,** Tenniel's Edition, with 68 Wood Engravings from Original Drawings and other Illustrations. Fcp. 4to. 21s.
- Moore's Irish Melodies,** Macclise's Edition, with 161 Steel Plates from Original Drawings. Super-royal 8vo. 31s. 6d.
- Miniature Edition of Moore's Irish Melodies,** with Macclise's Illustrations, (as above) reduced in Lithography. Imp. 16mo. 10s. 6d.
- Southey's Poetical Works,** with the Author's last Corrections and copyright Additions. Library Edition, in 1 vol. medium 8vo. with Portrait and Vignette, 14s. or in 10 vols. fcp. 3s. 6d. each.
- Lays of Ancient Rome ; with Ivry and the Armada.** By the Right Hon. LORD MACAULAY. 16mo. 4s. 6d.
- Lord Macaulay's Lays of Ancient Rome.** With 90 Illustrations on Wood, Original and from the Antique, from Drawings by G. SCHARF. Fcp. 4to. 21s.
- Miniature Edition of Lord Macaulay's Lays of Ancient Rome,** with Scharf's Illustrations (as above) reduced in Lithography. Imp. 16mo. 10s. 6d.
- Poems.** By JEAN INGELOW. Twelfth Edition. Fcp. 8vo. 5s.
- Poems by Jean Ingelow.** A New Edition, with nearly 100 Illustrations by Eminent Artists, engraved on Wood by the Brothers DALZIEL. Fcp. 4to. 21s.
- Poetical Works of Letitia Elizabeth Landon (L.E.L.)** 2 vols. 16mo. 10s.
- Playtime with the Poets : a Selection of the best English Poetry for the use of Children.** By a LADY. Crown 8vo. 5s.

**Bowdler's Family Shakspeare**, cheaper Genuine Edition, complete in 1 vol. large type, with 86 Woodcut Illustrations, price 14s. or, with the same ILLUSTRATIONS, in 6 pocket vols. 8s. 6d. each.

**Arundines Cami, sive Musarum Cantabrigiensium Lusæ Canori. Collegit atque edidit H. DRURY, M.A. Editio Sexta, curavit H. J. HODGSON, M.A. Crown 8vo. price 7s. 6d.**

**The Æneid of Virgil Translated into English Verse.** By JOHN CONINGTON, M.A. Corpus Professor of Latin in the University of Oxford. Crown 8vo. 9s.

**The Iliad of Homer Translated into Blank Verse.** By ICHABOD CHARLES WRIGHT, M.A. late Fellow of Magdalen Coll. Oxon. 2 vols. crown 8vo. 21s.

**The Iliad of Homer in English Hexameter Verse.** By J. HENRY DART, M.A. of Exeter College, Oxford; Author of 'The Exile of St. Helena, Newdigate, 1838.' Square crown 8vo. price 21s. cloth.

**Dante's Divine Comedy**, translated in English Terza Rima by JOHN DAYMAN, M.A. [With the Italian Text, after Brunetti, interpagated.] 8vo. 21s.

### *Rural Sports, &c.*

**Encyclopædia of Rural Sports;** a Complete Account, Historical, Practical, and Descriptive, of Hunting, Shooting, Fishing, Racing, &c. By D. P. BLAINE. With above 600 Woodcuts (20 from Designs by JOHN LEECH). 8vo. 42s.

**Notes on Rifle Shooting.** By Captain HEATON, Adjutant of the Third Manchester Rifle Volunteer Corps. Fcp. 2s. 6d.

**Col. Hawker's Instructions to Young Sportsmen** in all that relates to Guns and Shooting. Revised by the Author's Son. Square crown 8vo. with Illustrations. 18s.

**The Rifle, its Theory and Practice.** By ARTHUR WALKER (79th Highlanders), Staff, Hythe and Fleetwood Schools of Musketry. Second Edition. Crown 8vo. with 125 Woodcuts, 5s.

**The Dead Shot, or Sportsman's Complete Guide;** a Treatise on the Use of the Gun, Dog-breaking, Pigeon-shooting, &c. By MARKSMAN. Fcp. with Plates, 5s.

**Hints on Shooting, Fishing, &c.** both on Sea and Land and in the Fresh and Saltwater Lochs of Scotland. By C. INLE, Esq. Second Edition. Fcp. 6s.

**A Book on Angling:** being a Complete Work on every branch of Angling practised in Great Britain. By FRANCIS FRANCIS. With numerous Explanatory Plates, coloured and plain, and the largest and most reliable List of Salmon Flies ever published. Post 8vo.

**The Art of Fishing on the Principle of Avoiding Cruelty:** being a brief Treatise on the Most Merciful Methods of Capturing Fish; describing certain approved Rules in Fishing, used during 60 Years' Practice. By the Rev. O. RAYMOND, LL.B. Fcp. 8vo.

**Handbook of Angling:** Teaching Fly-fishing, Trolling, Bottom-fishing, Salmon-fishing; with the Natural History of River Fish, and the best modes of Catching them. By EPHEMERA. Fcp. Woodcuts, 5s.

**The Fly-Fisher's Entomology.** By ALFRED RONALDS. With coloured Representations of the Natural and Artificial Insect. Sixth Edition; with 20 coloured Plates. 8vo. 14s.

**The Cricket Field;** or, the History and the Science of the Game of Cricket. By JAMES PYCROFT, B.A. 4th Edition. Fcp. 6s.

**The Cricket Tutor;** a Treatise exclusively Practical. By the same. 18mo. 1s.

**Cricketana.** By the same Author. With 7 Portraits of Cricketers. Fcp. 6s.

**Youatt on the Horse.** Revised and enlarged by W. WATSON, M.R.C.V.S. 8vo. with numerous Woodcuts, 12s. 6d.

**Youatt on the Dog.** (By the same Author.) 8vo. with numerous Woodcuts, 6s.

**The Horse-Trainer's and Sportsman's Guide:** with Considerations on the Duties of Grooms, on Purchasing Blood Stock, and on Veterinary Examination. By DIGBY COLLINS. Post 8vo. 6s.

**Blaine's Veterinary Art:** a Treatise on the Anatomy, Physiology, and Curative Treatment of the Diseases of the Horse, Neat Cattle, and Sheep. Seventh Edition, revised and enlarged by C. STEEL, M.R.C.V.S.L. 8vo. with Plates and Woodcuts, 18s.

**On Drill and Manœuvres of Cavalry**, combined with Horse Artillery. By Major-Gen. MICHAEL W. SMITH, C.B. commanding the Poonah Division of the Bombay Army. 8vo. 12s. 6d.

**The Horse's Foot, and how to keep it Sound.** By W. MILES, Esq. 9th Edition, with Illustrations. Imp. 8vo. 12s. 6d.

**A Plain Treatise on Horse-shoeing.** By the same Author. Post 8vo. with Illustrations, 2s. 6d.

**Stables and Stable Fittings.** By the same. Imp. 8vo. with 13 Plates, 15s.

**Remarks on Horses' Teeth, addressed to Purchasers.** By the same. Post 8vo. 1s. 6d.

**The Dog in Health and Disease.** By STONEHENGE. With 70 Wood Engravings. New Edition. Square crown 8vo. 10s. 6d.

**The Greyhound.** By the same Author. Revised Edition, with 24 Portraits of Greyhounds. Square crown 8vo. 21s.

**The Ox, his Diseases and their Treatment; with an Essay on Parturition in the Cow.** By J. R. DOBSON, M.R.C.V.S. Crown 8vo. with Illustrations, 7s. 6d.

### *Commerce, Navigation, and Mercantile Affairs.*

**The Commercial Handbook of France;** Furnishing a detailed and comprehensive account of the Trade, Manufactures, Industry, and Commerce of France at the Present Time. By FREDERICK MARTIN. With Maps and Plans, including a Coloured Map showing the Seats of the Principal Industries. Crown 8vo.

**Banking, Currency, and the Exchanges:** a Practical Treatise. By ARTHUR CRUMP, Bank Manager, formerly of the Bank of England. Post 8vo. 6s.

**The Theory and Practice of Banking.** By HENRY DUNNING MACLEOD, M.A. Barrister-at-Law. Second Edition, entirely remodelled. 2 vols. 8vo. 30s.

**A Dictionary, Practical, Theoretical, and Historical, of Commerce and Commercial Navigation.** By J. R. McCULLOCH. New Edition in preparation.

**Practical Guide for British Shipmasters to United States Ports.** By PIERRE-REPOET EDWARDS, Her Britannic Majesty's Vice-Consul at New York. Post 8vo. 8s. 6d.

**A Manual for Naval Cadets.** By J. McNEIL BOYD, late Captain R.N. Third Edition; with 240 Woodcuts, and 11 coloured Plates. Post 8vo. 12s. 6d.

**The Law of Nations Considered as Independent Political Communities.** By TRAVERS TWISS, D.C.L. Regius Professor of Civil Law in the University of Oxford. 2 vols. 8vo. 80s. or separately, PART I. *Peace*, 12s. PART II. *War*, 18s.

**A Nautical Dictionary, defining the Technical Language relative to the Building and Equipment of Sailing Vessels and Steamers, &c.** By ARTHUR YOUNG. Second Edition; with Plates and 150 Woodcuts. 8vo. 18s.

### *Works of Utility and General Information.*

**Modern Cookery for Private Families, reduced to a System of Easy Practice in a Series of carefully-tested Receipts.** By ELIZA ACTON. Newly revised and enlarged; with 8 Plates, Figures, and 150 Woodcuts. Fcp. 7s. 6d.

**On Food and its Digestion; an Introduction to Dietetics.** By W. BRINTON, M.D. Physician to St. Thomas's Hospital, &c. With 48 Woodcuts. Post 8vo. 12s.

**Wine, the Vine, and the Cellar.** By THOMAS G. SHAW. Second Edition, revised and enlarged, with Frontispiece and 81 Illustrations on Wood. 8vo. 16s.

**A Practical Treatise on Brewing; with Formulae for Public Brewers, and Instructions for Private Families.** By W. BLACK. Fifth Edition. 8vo. 10s. 6d.

**How to Brew Good Beer: a complete Guide to the Art of Brewing Ale, Bitter Ale, Table Ale, Brown Stout, Porter, and Table Beer.** By JOHN PITT. Revised Edition. Fcp. 4s. 6d.

**The Billiard Book.** By Captain CRAWLEY, Author of 'Billiards, its Theory and Practice,' &c. With nearly 100 Diagrams on Steel and Wood. 8vo. 21s.

**Whist, What to Lead.** By CAM. Third Edition. 82mo. 1s.

**Short Whist.** By MAJOR A. The Sixteenth Edition, revised, with an Essay on the Theory of the Modern Scientific Game by PROF. P. Fcp. 8s. 6d.

**Two Hundred Chess Problems,** composed by F. HEALEY, including the Problems to which the Prizes were awarded by the Committees of the Era, the Manchester, the Birmingham, and the Bristol Chess Problem Tournaments; accompanied by the SOLUTIONS. Crown 8vo. with 200 Diagrams, 5s.

**The Cabinet Lawyer;** a Popular Digest of the Laws of England, Civil, Criminal, and Constitutional. 22nd Edition, entirely recomposed, and brought down by the AUTHOR to the close of the Parliamentary Session of 1866. Fcp. 10s. 6d.

**The Philosophy of Health;** or, an Exposition of the Physiological and Sanitary Conditions conducive to Human Longevity and Happiness. By SOUTHWOOD SMITH, M.D. Eleventh Edition, revised and enlarged; with 118 Woodcuts. 8vo. 15s.

**Hints to Mothers on the Management** of their Health during the Period of Pregnancy and in the Lying-in Room. By T. BULL, M.D. Fcp. 5s.

**The Maternal Management of Children** in Health and Disease. By the same Author. Fcp. 5s.

**Notes on Hospitals.** By FLORENCE NIGHTINGALE. Third Edition, enlarged; with 18 Plans. Post 4to. 18s.

**The Executor's Guide.** By J. C. HUDSON. Enlarged Edition, revised by the Author, with reference to the latest reported Cases and Acts of Parliament. Fcp. 6s.

**Hudson's Plain Directions for Making** Wills. Fcp. 2s. 6d.

**The Law relating to Benefit** Building Societies; with Practical Observations on the Act and all the Cases decided thereon, also a Form of Rules and Forms of Mortgages. By W. TIDD PRATT, Barrister. 2nd Edition. Fcp. 3s. 6d.

**C. M. Willich's Popular Tables** for Ascertaining the Value of Lifehold, Leasehold, and Church Property, Renewal Fines, &c.; the Public Funds; Annual Average Price and Interest on Consols from 1781 to 1861; Chemical, Geographical, Astronomical, Trigonometrical Tables, &c. Post 8vo. 10s.

**Thomson's Tables of Interest,** at Three, Four, Four and a Half, and Five per Cent, from One Pound to Ten Thousand and from 1 to 365 Days. 12mo. 3s. 6d.

**Maunder's Treasury of Knowledge** and Library of Reference: comprising an English Dictionary and Grammar, Universal Gazetteer, Classical Dictionary, Chronology, Law Dictionary, Synopsis of the Peerage, useful Tables, &c. Fcp. 10s. 6d.

### *Knowledge for the Young.*

**The Stepping Stone to Knowledge:** Containing upwards of 700 Questions and Answers on Miscellaneous Subjects, adapted to the capacity of Infant Minds. By a MOTHER. 18mo. price 1s.

**The Stepping Stone to Geography:** Containing several Hundred Questions and Answers on Geographical Subjects. 18mo. 1s.

**The Stepping Stone to English History:** Containing several Hundred Questions and Answers on the History of England. 1s.

**The Stepping Stone to Bible Knowledge:** Containing several Hundred Questions and Answers on the Old and New Testaments. 18mo. 1s.

**The Stepping Stone to Biography:** Containing several Hundred Questions and Answers on the Lives of Eminent Men and Women. 18mo. 1s.

**Second Series of the Stepping Stone to Knowledge:** containing upwards of Eight Hundred Questions and Answers on Miscellaneous Subjects not contained in the FIRST SERIES. 18mo. 1s.

**The Stepping Stone to French Pronunciation and Conversation:** Containing several Hundred Questions and Answers. By Mr. P. SADLER. 18mo. 1s.

**The Stepping Stone to English Grammar:** containing several Hundred Questions and Answers on English Grammar. By Mr. P. SADLER. 18mo. 1s.

**The Stepping Stone to Natural History:** VERTEBRATE or BACKBONED ANIMALS. PART I. *Mammalia*; PART II. *Birds, Reptiles, Fishes*. 18mo. 1s. each Part.

# INDEX.

<p> <b>ABBOTT</b> on Sight and Touch ..... 7  <b>ACTON's</b> Modern Cookery ..... 19  <b>ALCOCK's</b> Residence in Japan ..... 16  <b>ALLIES</b> on Formation of Christianity ..... 14  <b>ALPINE</b> Guide (The) ..... 16  <b>AFJOHN's</b> Manual of the Metalloids..... 8  <b>ARAGO's</b> Biographies of Scientific Men ..... 4          — Popular Astronomy ..... 7  <b>ARNOLD's</b> Manual of English Literature... 5  <b>ARNOTT's</b> Elements of Physics ..... 7  <b>ARUNDINES</b> Cami ..... 18  <b>Atherstone</b> Priory ..... 16  <b>Autumn</b> Holidays of a Country Parson .... 6  <b>AYRE's</b> Treasury of Bible Knowledge ..... 14         </p> <p> <b>BACON's</b> Essays, by <b>WHATELY</b> ..... 4          — Life and Letters, by <b>SPEDDING</b>... 3          — Works ..... 4  <b>BAIN</b> on the Emotions and Will ..... 7          — on the Senses and Intellect ..... 7          — on the Study of Character ..... 7  <b>BAINES's</b> Explorations in S.W. Africa .... 15  <b>BALL's</b> Guide to the Central Alps ..... 12          — Guide to the Western Alps ..... 12          — Guide to the Eastern Alps ..... 16  <b>BARNARD's</b> Drawing from Nature ..... 12  <b>BAYLDON's</b> Rents and Tillages ..... 13  <b>Beaten</b> Tracks ..... 15  <b>BECKER's</b> <i>Charicles</i> and <i>Gallus</i> ..... 16  <b>BETHOVEN's</b> Letters ..... 3  <b>BRENFY's</b> Sanskrit-English Dictionary .... 5  <b>BERRY's</b> Journals ..... 3  <b>BLACK's</b> Treatise on Brewing ..... 19  <b>BLACKLEY</b> and <b>FRIEDLANDER's</b> German and English Dictionary ..... 5  <b>BLAINE's</b> Rural Sports ..... 18          — Veterinary Art ..... 18  <b>BLIGHT's</b> Week at the Land's End ..... 16  <b>BOASE's</b> Essay on Human Nature ..... 6          — Philosophy of Nature ..... 6  <b>BONER's</b> Transylvania ..... 15  <b>BOOTH's</b> Epigrams ..... 6  <b>BOURNE</b> on Screw Propeller ..... 12  <b>BOURNE's</b> Catechism of the Steam Engine.. 12          — Handbook of Steam Engine ..... 12          — Treatise on the Steam Engine... 12  <b>BOWDLER's</b> Family <b>SHAKESPEARE</b> ..... 18  <b>BOYD's</b> Manual for Naval Cadets ..... 19  <b>BRAMLEY-MOORE's</b> Six Sisters of the Valleys 16  <b>BRANDER's</b> Dictionary of Science, Literature, and Art ..... 9  <b>BRAY's</b> (C.) Education of the Feelings..... 7          — Philosophy of Necessity..... 7          — On Force ..... 7  <b>BRINTON</b> on Food and Digestion ..... 19  <b>BRISTOW's</b> Glossary of Mineralogy ..... 8  <b>BRODIE's</b> Constitutional History ..... 1         </p>	<p> <b>BRODIE's</b> (Sir C. B.) Works..... 10          — Autobiography..... 10  <b>BROWNE's</b> Ice Caves of France and Switzerland ..... 15          — Exposition 39 Articles ..... 13          — Pentateuch ..... 13  <b>BUCKLE's</b> History of Civilization ..... 2  <b>BULL's</b> Hints to Mothers ..... 20          — Maternal Management of Children.. 20  <b>BUNSEN's</b> Ancient Egypt..... 2  <b>BUNSEN</b> on Apocrypha ..... 14  <b>BURKE's</b> Vicissitudes of Families ..... 4  <b>BURTON's</b> Christian Church ..... 3         </p> <p> <b>Cabinet</b> Lawyer..... 20  <b>CALVERT's</b> Wife's Manual ..... 14  <b>Campaigner</b> at Home..... 6  <b>CATS</b> and <b>FARLIE's</b> Moral Emblems..... 11  <b>Chorale</b> Book for England ..... 15  <b>CLOUGH's</b> Lives from Plutarch ..... 2  <b>COLENSO</b> (Bishop) on Pentateuch and Book of Joshua..... 14  <b>COLLINS's</b> Horse Trainer's Guide..... 18  <b>COLUMBUS's</b> Voyages..... 16  <b>Commonplace</b> Philosopher in Town and Country ..... 6  <b>CONINGTON's</b> Translation of Virgil's <i>Æneid</i> 18  <b>CONTANSEAU's</b> Two French and English Dictionaries ..... 5  <b>CONYBEARE</b> and <b>HOWSON's</b> Life and Epistles of St. Paul ..... 13  <b>COOK's</b> Acts of the Apostles..... 13          — Voyages ..... 16  <b>COPLAND's</b> Dictionary of Practical Medicine 10  <b>Cox's</b> Tales of the Great Perseian War ..... 2          — Tales from Greek Mythology..... 17          — Tales of the Gods and Heroes..... 17          — Tales of Thebes and Argos ..... 17  <b>CRAWLEY's</b> Billiard Book ..... 19  <b>CRESY's</b> Encyclopædia of Civil Engineering 11  <b>Critical</b> Essays of a Country Parson..... 6  <b>CROWE's</b> History of France..... 2  <b>CRUMP</b> on Banking, &amp;c. .... 19  <b>CUSSANS's</b> Grammar of Heraldry..... 12         </p> <p> <b>DART's</b> Iliad of Homer ..... 18  <b>D'AUBIGNE's</b> History of the Reformation in the time of CALVIN ..... 2  <b>DAYMAN's</b> Dante's Divina Commedia..... 18  <b>Dead</b> Shot (The), by <b>MARKSMAN</b> ..... 18  <b>DE LA RIVE's</b> Treatise on Electricity ..... 8  <b>DELMARD's</b> Village Life in Switzerland... 15  <b>DE LA FRYME's</b> Life of Christ ..... 14  <b>DE MORGAN</b> on Matter and Spirit ..... 6  <b>DE TOCQUEVILLE's</b> Democracy in America 2  <b>DISRAELI's</b> Speeches on Reform ..... 5  <b>DOBSON</b> on the Ox ..... 19         </p>
---	--

DUNCAN and MILLARD on Classification, &c. of the Idiomatic..... 11  
 DYER's City of Rome..... 2

EDWARDS's Shipmaster's Guide ..... 19  
 Elements of Botany ..... 9  
 Ellice, a Tale..... 16  
 ELLICOTT's Broad and Narrow Way..... 13  
 ——— Commentary on Ephesians ..... 13  
 ——— Destiny of the Creature..... 13  
 ——— Lectures on Life of Christ ..... 13  
 ——— Commentary on Galatians ..... 13  
 ——— Pastoral Epist. .... 13  
 ——— Philippians, &c. .... 13  
 ——— Thessalonians ..... 13  
 ENGL's Introduction to National Music .. 11  
 Essays and Reviews ..... 14  
 ——— on Religion and Literature, edited by MANNING ..... 13

FAIRBAIRN's Application of Cast and Wrought Iron to Building..... 12  
 ——— Information for Engineers .. 12  
 ——— Treatise on Mills & Millwork 12  
 FAIRBAIRN on Iron Ship Building ..... 11  
 FARRAR's Chapters on Language ..... 5  
 FFOLKES's Christendom's Divisions..... 14  
 FRANCIS's Fishing Book ..... 18  
 FROUDE's History of England..... 1

GER's Our Sermons ..... 15  
 ——— Sunday to Sunday ..... 15

GILBERT and CHURCHILL's Dolomite Mountains ..... 16  
 GILLY's Shipwrecks of the Navy ..... 16  
 GOETHE's Second Faust, by Anster ..... 17  
 GOODEVE's Elements of Mechanism..... 13  
 GORLE's Questions on BROWNE's Exposition of the 39 Articles ..... 13  
 GRANT's Ethics of Aristotle ..... 4  
 Graver Thoughts of a Country Parson..... 6  
 GRAY's Anatomy..... 10  
 GREENE's Corals and Sea Jellies ..... 8  
 ——— Sponges and Animalculæ ..... 8  
 GROVE on Correlation of Physical Forces .. 8  
 GWILF's Encyclopædia of Architecture .... 12

Handbook of Angling, by EPHEMERA..... 18  
 HARB on Election of Representatives ..... 5  
 HARLEY and BROWN's Histological Demonstrations ..... 10  
 HARTWIG's Harmonies of Nature..... 8  
 ——— Sea and its Living Wonders..... 8  
 ——— Tropical World ..... 8  
 HAUGHTON's Manual of Geology ..... 8  
 HAWKER's Instructions to Young Sportsmen ..... 18  
 HEATON's Notes on Rifle Shooting ..... 18  
 HEALEY's Chess Problems ..... 20  
 HELPS's Spanish Conquest in America ..... 2  
 HENDERSON's Folk-Lore ..... 6  
 HERSCHEL's Essays from Reviews ..... 9  
 ——— Outlines of Astronomy ..... 7  
 HEWITT on the Diseases of Women ..... 10  
 HODGSON's Time and Space..... 7  
 HOLLAND's Essays on Scientific Subjects .. 9  
 HOLMES's System of Surgery..... 10

HOOKE and WALKER-ARNOTT's British Flora..... 9  
 HOPKINS's Hawaii ..... 7  
 HORNE's Introduction to the Scriptures... 14  
 ——— Manual of the Scriptures .. 14  
 HORSLEY's Manual of Poisons ..... 9  
 HOSKYN's Occasional Essays ..... 6  
 ——— Talpa ..... 18  
 How we Spent the Summer ..... 15  
 HOWITT's Australian Discovery ..... 16  
 ——— Rural Life of England ..... 16  
 ——— Visits to Remarkable Places .... 16  
 HUDSON's Directions for Making Wills .... 20  
 ——— Executor's Guide..... 20  
 HUGHES's (W.) Manual of Geography..... 7  
 HULLAN's History of Modern Music ..... 11  
 ——— Transition Musical Lectures ..... 11  
 ——— Part Music..... 11  
 ——— Sacred Music ..... 11  
 HUMBOLDT's Travels in South America.... 16  
 HUMPHREYS's Sentiments of Shakspeare... 11  
 HUTTON's Studies in Parliament ..... 6  
 Hymns from *Lyra Germanica*..... 14

INGELOW's Poems ..... 17  
 Icelandic Legends, SECOND SERIES..... 17  
 IDLE's Hints on Shooting ..... 18

JAMESON's Legends of the Saints and Martyrs ..... 11  
 ——— Legends of the Madonna ..... 21  
 ——— Legends of the Monastic Orders 11  
 JAMESON and EASTLAKE's History of Our Lord ..... 11  
 JOHNSON's Patentee's Manual ..... 12  
 ——— Practical Draughtsman ..... 12  
 JOHNSTON's Gazetteer, or General Geographical Dictionary ..... 7  
 JONES's Christianity and Common Sense .. 7  
 JORDAN's Elements ..... 8

KALISCH's Commentary on the Bible..... 5  
 ——— Hebrew Grammar..... 5  
 KELLER's Lake Dwellings of Switzerland .. 8  
 KESTEVEN's Domestic Medicine ..... 10  
 KIRBY and SPENCER's Entomology ..... 9  
 KUENEN on Pentateuch and Joshua..... 14

Lady's Tour round Monte Rosa ..... 16  
 LONDON's (L. E. L.) Poetical Works..... 17  
 LATHAM's English Dictionary ..... 5  
 LAWRENCE on Rocks ..... 8  
 LECKY's History of Rationalism ..... 2  
 Leisure Hours in Town ..... 6  
 LEWIS's Biographical History of Philosophy 2  
 LEWIN's Fasti Sacri ..... 13  
 LEWIS on Early Roman History ..... 4  
 ——— on Irish Disturbances ..... 4  
 ——— on Observation and Reasoning in Politics..... 4  
 ——— on Political Terms ..... 4  
 LEWIS's Essays on Administrations..... 4  
 ——— Fables of BARRIUS..... 4  
 LIDDELL and SCOTT's Greek-English Lexicon 5  
 ——— Abridged ditto ..... 5  
 Life of Man Symbolised ..... 11  
 LINDLEY and MOORE's Treasury of Botany 9

<b>LONGMAN'S Lectures on History of England</b> .....	1	<b>MILLER'S Elements of Chemistry</b> .....	9
<b>LOUDON'S Encyclopedia of Agriculture</b> ....	13	<b>MONSELL'S Spiritual Songs</b> .....	15
Gardening .....	13	Beatitudes.....	15
Plants .....	9	<b>MONTGOMERY on Pregnancy</b> .....	10
Trees and Shrubs .....	9	<b>MOORE'S Irish Melodies</b> .....	11, 17
Cottage, Farm, and Villa Architecture	13	Lalla Rookh .....	17
<b>LOWNDES'S Engineer's Handbook</b> .....	12	Journal and Correspondence ....	3
<b>LYRA Domestica</b> .....	14	Poetical Works.....	17
Eucharistica.....	15	(Dr. G.) First Man .....	8
Germanica .....	11, 15	<b>MORELL'S Elements of Psychology</b> .....	6
Messianica .....	15	Mental Philosophy.....	6
Mystica .....	15	<b>MOSHEIM'S Ecclesiastical History</b> .....	14
Sacra .....	15	<b>MOZART'S Letters</b> .....	3
<b>MACAULAY'S (Lord) Essays</b> .....	2	<b>MÜLLER'S (Max) Lectures on the Science of</b>	
History of England .....	1	Language .....	5
Lays of Ancient Rome.....	17	(K. O.) Literature of Ancient	
Miscellaneous Writings .....	6	Greece .....	2
Speeches .....	5	<b>MURCHISON on Continued Fevers</b> .....	10
Works .....	1	<b>MURR'S Language and Literature of Greece</b>	2
<b>MACFARREN'S Lectures on Harmony</b> .....	11		
<b>MACLEOD'S Elements of Political Economy</b>	4	<b>New Testament illustrated with Wood En-</b>	
Dictionary of Political Economy .....	4	gravings from the Old Masters .....	11
Theory and Practice of Banking .....	19	<b>NEWMAN'S History of his Religious Opinions</b>	3
<b>McCULLOCH'S Dictionary of Commerce</b> ....	18	<b>NIGHTINGALE'S Notes on Hospitals</b> .....	20
Geographical Dictionary .....	7		
<b>MACFIE'S Vancouver Island</b> .....	15	<b>ODLING'S Animal Chemistry</b> .....	9
<b>MAQUIRE'S Life of Father Mathew</b> .....	3	Course of Practical Chemistry....	9
Rome and its Rulers .....	3	Manual of Chemistry .....	9
<b>MALING'S Indoor Gardener</b> .....	9	<b>O'SHEA'S Guide to Spain</b> .....	16
<b>MANNING on Holy Ghost</b> .....	14	<b>OWEN'S Comparative Anatomy and Physio-</b>	
<b>MARSHMAN'S History of India</b> .....	2	logy of Vertebrate Animals .....	8
Life of Havelock .....	3	<b>OXENHAM on Atonement</b> .....	15
<b>MARTIN'S Commercial Handbook of France</b>	19		
<b>MASSEY'S History of England</b> .....	1	<b>PAGE'S Guide to the Pyrenees</b> .....	16
<b>MASSINGBERD'S History of the Reformation</b>	3	<b>PAGET'S Lectures on Surgical Pathology</b> ..	10
<b>MAUNDER'S Biographical Treasury</b> .....	4	<b>PEREIRA'S Elements of Materia Medica</b> ....	10
Geographical Treasury .....	7	Manual of Materia Medica.....	10
Historical Treasury .....	2	<b>PERKINS'S Tuscan Sculptors</b> .....	12
Scientific and Literary Treasury ;	9	<b>PHILLIPS'S Guide to Geology</b> .....	8
Treasury of Knowledge.....	20	Introduction to Mineralogy....	8
Treasury of Natural History ..	9	<b>PIESSE'S Art of Perfumery</b> .....	13
<b>MAURY'S Physical Geography</b> .....	7	Chemical, Natural, and Physical Magic	13
<b>MAY'S Constitutional History of England</b> ..	1	<b>PITT on Brewing</b> .....	19
<b>MELVILLE'S Digby Grand</b> .....	17	Playtime with the Poets.....	17
General Bounce .....	17	<b>Practical Mechanic's Journal</b> .....	12
Gladiators .....	17	<b>PRATT'S Law of Building Societies</b> .....	20
Good for Nothing .....	17	<b>PRESCOTT'S Scripture Difficulties</b> .....	14
Holmby House .....	17	<b>PROCTOR'S Handbook of the Stars</b> .....	7
Interpreter .....	17	Saturn .....	7
Kate Coventry.....	17	<b>PYCROFT'S Course of English Reading</b> ....	5
Queen's Maries .....	17	Cricket Field .....	18
<b>MENDELSSOHN'S Letters</b> .....	3	Cricket Tutor .....	18
<b>MENZIES' Windsor Great Park</b> .....	13	Cricketana .....	18
<b>MERRIVALE'S (H.) Historical Studies</b> .....	1		
(C.) Fall of the Roman Republic	2	<b>RAYMOND on Fishing without Cruelty</b> .....	18
Romans under the Empire .....	2	<b>READER'S Poetical Works</b> .....	17
Boyle Lectures .....	2	<b>Recreations of a Country Parson</b> .....	6
<b>MILES on Horse's Foot and Horse Shoeing</b> ..	19	<b>REILLY'S Map of Mont Blanc</b> .....	15
on Horses' Teeth and Stables .....	19	<b>RIVERS'S Rose Amateur's Guide</b> .....	9
<b>MILL on Liberty</b> .....	4		
on Representative Government .....	4		
on Utilitarianism.....	4		
<b>MILL'S Dissertations and Discussions</b> .....	4		
Political Economy .....	4		
System of Logic.....	4		
Hamilton's Philosophy .....	4		



ROGERS's Correspondence of Greyson.....	6	TASSO's Jerusalem, by JAMES.....	17
— Eclipse of Faith.....	6	TAYLOR's (Jeremy) Works, edited by EDEX	14
— Defence of ditto .....	6	TENNENT's Ceylon.....	8
— Essays from the <i>Edinburgh Review</i>	6	— Natural History of Ceylon .....	8
— Fulleriana .....	6	— Wild Elephant .....	8
— Reason and Faith.....	6	THIRLWALL's History of Greece .....	2
— (E.) Fifth-Monarchy Man .....	3	THOMSON's (Archbishop) Laws of Thought	4
ROGET's Thesaurus of English Words and		— (J.) Tables of Interest .....	20
Phrases .....	5	— Conspectus, by BIRKETT.....	10
RONALDS's Fly-Fisher's Entomology .....	18	TODD's Cyclopædia of Anatomy and Physio-	
ROWTON's Debater.....	5	logy .....	10
RUSSELL on Government and Constitution.	1	— and BOWMAN's Anatomy and Physio-	
		logy of Man .....	10
SANDARS's Justinian's Institutes .....	4	TROLLOPE's Barchester Towers .....	17
SCOTT's Handbook of Volumetrical Analysis	9	— Warden .....	17
— Lectures on the Fine Arts.....	11	TWISS's Law of Nations .....	19
SCROPE on Volcanos .....	7	TYNDALL's Lectures on Heat.....	8
SEWELL's Amy Herbert.....	16	— Lectures on Sound.....	8
— Cleve Hall .....	16		
— Earl's Daughter.....	16	URE's Dictionary of Arts, Manufactures, and	
— Experience of Life .....	16	Mines .....	12
— Gertrude .....	16		
— Glimpse of the World.....	16	VAN DER HOEVEN's Handbook of Zoology	8
— History of the Early Church.....	3	VAUGHAN's (R.) Revolutions in English	
— Ivora .....	16	History .....	1
— Katharine Ashton.....	16	— (R. A.) Hours with the Mystics	7
— Laneton Parsonage .....	16	— Way to Rest.....	7
— Margaret Percival.....	16		
— Passing Thoughts on Religion.....	14	WALKER on the Rifle.....	18
— Preparation for Communion.....	14	WATSON's Principles and Practice of Physic	10
— Principles of Education.....	14	WATTS's Dictionary of Chemistry.....	9
— Readings for Confirmation .....	14	WEBB's Objects for Common Telescopes ..	7
— Readings for Lent.....	14	WEBSTER & WILKINSON's Greek Testament	13
— Examination for Confirmation ..	14	WELD's Florence.....	16
— Stories and Tales .....	16	WELLINGTON's Life, by BRIALMONT and	
— Thoughts for the Holy Week.....	14	GLEIG .....	3
— Ursula .....	16	— by GLEIG .....	3
SHAW's Work on Wine .....	19	WEST on Children's Diseases .....	9
SHEDDEN's Elements of Logic .....	4	WHATELY's English Synonymes .....	4
SHIPLEY's Church and the World .....	14	— Life and Correspondence.....	3
Short Whist .....	20	— Logic .....	4
SHORT's Church History .....	3	— Remains.....	4
SIEVEKING's (AMELIA) Life, by WINK-		— Rhetoric .....	4
WORTH .....	3	— Paley's Moral Philosophy .....	13
SMITH's (SOUTHWOOD) Philosophy of Health	20	WHEWELL's History of the Inductive Sci-	
— (J.) Paul's Voyage and Shipwreck	13	ences.....	2
— (G.) Wesleyan Methodism .....	3	Whist, what to lead, by CAM .....	20
— (SYDNEY) Miscellaneous Works ..	6	WHITE and RIDDLE's Latin-English Dic-	
— Moral Philosophy .....	6	tionaries .....	5
— Wit and Wisdom .....	6	WILBERFORCE (W.) Recollections of, by	
SMITH on Cavalry Drill and Manœuvres....	18	HARFORD .....	3
SOUTHEY's (Doctor) .....	5	WILLICH's Popular Tables .....	20
— Poetical Works.....	17	WILSON's Bryology Britannica.....	9
STANLEY's History of British Birds.....	9	WINDHAM's Diary.....	3
STEBBING's Analysis of MILL's Logic.....	5	WOOD's Homes without Hands .....	8
STEPHEN's Essays in Ecclesiastical Bio-		WOODWARD's Historical and Chronological	
graphy.....	4	Encyclopædia .....	2
— Lectures on History of France	2	WRIGHT's Homer's Iliad.....	18
STEPHENSON's Life, by JEAFFERSON and			
POLE.....	3	YONGE's English-Greek Lexicon .....	5
Stepping-Stone (The) to Knowledge, &c. ..	20	— Abridged ditto .....	5
STIRLING's Secret of Hegel .....	6	YOUNG's Nautical Dictionary .....	19
STONEHENGE on the Dog.....	19	YOUATT on the Dog .....	18
— on the Greyhound .....	19	— on the Horse .....	18
STRANGE on Sea Air .....	10		
— Restoration of Health .....	11		
Sunday Afternoons at the Parish Church....	6		

11  
12  
13  
14  
15  
16  
17  
18  
19  
20  
21  
22  
23  
24  
25  
26  
27  
28  
29  
30  
31  
32  
33  
34  
35  
36  
37  
38  
39  
40  
41  
42  
43  
44  
45  
46  
47  
48  
49  
50  
51  
52  
53  
54  
55  
56  
57  
58  
59  
60  
61  
62  
63  
64  
65  
66  
67  
68  
69  
70  
71  
72  
73  
74  
75  
76  
77  
78  
79  
80  
81  
82  
83  
84  
85  
86  
87  
88  
89  
90  
91  
92  
93  
94  
95  
96  
97  
98  
99  
100





