

SECOND EDITION

Spellman's
Standard Handbook *for*
Wastewater Operators

VOLUME III

Advanced Level



Frank R. Spellman

SECOND EDITION

Spellman's
Standard Handbook *for*
Wastewater Operators

VOLUME III

SECOND EDITION

Spellman's
Standard Handbook *for*
Wastewater Operators

VOLUME III

Advanced Level

Frank R. Spellman



CRC Press

Taylor & Francis Group

Boca Raton London New York

CRC Press is an imprint of the
Taylor & Francis Group, an **informa** business

CRC Press
Taylor & Francis Group
6000 Broken Sound Parkway NW, Suite 300
Boca Raton, FL 33487-2742

© 2011 by Taylor and Francis Group, LLC
CRC Press is an imprint of Taylor & Francis Group, an Informa business

No claim to original U.S. Government works

Printed in the United States of America on acid-free paper
10 9 8 7 6 5 4 3 2 1

International Standard Book Number-13: 978-1-4398-1889-3 (Ebook-PDF)

This book contains information obtained from authentic and highly regarded sources. Reasonable efforts have been made to publish reliable data and information, but the author and publisher cannot assume responsibility for the validity of all materials or the consequences of their use. The authors and publishers have attempted to trace the copyright holders of all material reproduced in this publication and apologize to copyright holders if permission to publish in this form has not been obtained. If any copyright material has not been acknowledged please write and let us know so we may rectify in any future reprint.

Except as permitted under U.S. Copyright Law, no part of this book may be reprinted, reproduced, transmitted, or utilized in any form by any electronic, mechanical, or other means, now known or hereafter invented, including photocopying, microfilming, and recording, or in any information storage or retrieval system, without written permission from the publishers.

For permission to photocopy or use material electronically from this work, please access www.copyright.com (<http://www.copyright.com/>) or contact the Copyright Clearance Center, Inc. (CCC), 222 Rosewood Drive, Danvers, MA 01923, 978-750-8400. CCC is a not-for-profit organization that provides licenses and registration for a variety of users. For organizations that have been granted a photocopy license by the CCC, a separate system of payment has been arranged.

Trademark Notice: Product or corporate names may be trademarks or registered trademarks, and are used only for identification and explanation without intent to infringe.

Visit the Taylor & Francis Web site at
<http://www.taylorandfrancis.com>

and the CRC Press Web site at
<http://www.crcpress.com>

TABLE OF CONTENTS

PREFACE, 2ND EDITION	xv
ABOUT THE AUTHOR	xvii
CHAPTER 1 WATER ECOLOGY	1
1.1 INTRODUCTION	1
1.2 WHAT IS ECOLOGY?	2
1.3 WHY IS ECOLOGY IMPORTANT?	4
1.4 WHY STUDY ECOLOGY?	5
1.4.1 LEAF PROCESSING IN STREAMS	6
1.5 HISTORY OF ECOLOGY	8
1.5.1 EXAMPLE ECOSYSTEM: AGROECOSYSTEM MODEL	11
1.5.1.1 AGROECOSYSTEM CHARACTERISTICS	11
1.5.1.2 ECOSYSTEM PATTERN AND PROCESS	12
1.6 LEVELS OF ORGANIZATION	12
1.7 ECOSYSTEMS	13
1.8 ENERGY FLOW IN THE ECOSYSTEM	15
1.9 FOOD CHAIN EFFICIENCY	16
1.10 ECOLOGICAL PYRAMIDS	17
1.11 PRODUCTIVITY	18
1.12 POPULATION ECOLOGY	19
1.13 STREAM GENESIS AND STRUCTURE	25
1.13.1 WATER FLOW IN A STREAM	27
1.13.2 STREAM WATER DISCHARGE	28
1.13.3 TRANSPORT OF MATERIAL	29
1.13.4 CHARACTERISTICS OF STREAM CHANNELS	30
1.13.5 STREAM PROFILES	30
1.13.6 SINUOSITY	31
1.13.7 BARS, RIFFLES, AND POOLS	31
1.13.8 THE FLOOD PLAIN	32
1.13.9 ADAPTATIONS TO STREAM CURRENT	36
1.13.9.1 TYPES OF ADAPTIVE CHANGES	37
1.13.9.2 SPECIFIC ADAPTATIONS	37
1.14 BENTHIC LIFE	38
1.15 BENTHIC PLANTS AND ANIMALS	39

1.16	BENTHIC MACROINVERTEBRATES	39
1.16.1	IDENTIFICATION OF BENTHIC MACROINVERTEBRATES	41
1.16.2	MACROINVERTEBRATES AND THE FOOD WEB	42
1.16.3	UNITS OF ORGANIZATION	43
1.17	TYPICAL BENTHIC MACROINVERTEBRATES IN RUNNING WATERS	43
1.17.1	INSECT MACROINVERTEBRATES	43
1.17.1.1	MAYFLIES (ORDER: EPHEMEROPTERA)	44
1.17.1.2	STONEFLIES (ORDER: PLECOPTERA)	44
1.17.1.3	CADDISFLIES (ORDER: TRICHOPTERA)	45
1.17.1.4	TRUE FLIES (ORDER: DIPTERA)	47
1.17.1.5	BETLES (ORDER: COLEOPTERA)	48
1.17.1.6	WATER STRIDER ("JESUS BUGS") (ORDER: HEMIPTERA)	51
1.17.1.7	ALDERFLIES AND DOBSONFLIES (ORDER: MEGALOPTERA)	52
1.17.1.8	DRAGONFLIES AND DAMSELFLIES (ORDER: ODONATA)	53
1.17.2	NON-INSECT MACROINVERTEBRATES	54
1.17.2.1	OLIGOCHAETA (FAMILY TUBIFICIDAE, GENUS TUBIFEX)	55
1.17.2.2	HIRUDINEA (LEECHES)	55
1.17.2.3	GASTROPODA (LUNG-BREATHING SNAIL)	55
1.18	SUMMARY OF KEY TERMS	56
1.19	CHAPTER REVIEW QUESTIONS	57
	REFERENCES AND RECOMMENDED READING	57
CHAPTER 2 BASIC WATER CHEMISTRY		61
2.1	CHEMISTRY CONCEPTS AND DEFINITIONS	62
2.1.1	CONCEPTS	62
2.1.1.1	MISCIBLE AND SOLUBILITY	62
2.1.1.2	SUSPENSION, SEDIMENT, PARTICLES, AND SOLIDS	62
2.1.1.3	EMULSION	62
2.1.1.4	ION	63
2.1.1.5	MASS CONCENTRATION	63
2.1.2	DEFINITIONS	63
2.2	CHEMISTRY FUNDAMENTALS	65
2.2.1	MATTER	65
2.2.2	THE CONTENT OF MATTER: THE ELEMENTS	67
2.2.3	COMPOUND SUBSTANCES	69
2.3	WATER SOLUTIONS	71
2.4	WATER CONSTITUENTS	73
2.4.1	SOLIDS	73
2.4.2	TURBIDITY	73
2.4.3	COLOR	74
2.4.4	DISSOLVED OXYGEN	74
2.4.5	METALS	75
2.4.6	ORGANIC MATTER	75
2.4.7	INORGANIC MATTER	76
2.4.8	ACIDS	76

2.4.9	BASES	77
2.4.10	SALTS	77
2.4.11	pH	77
2.5	COMMON WATER MEASUREMENTS	78
2.5.1	ALKALINITY	79
2.5.2	WATER TEMPERATURE	79
2.5.3	SPECIFIC CONDUCTANCE	80
2.5.4	HARDNESS	80
2.5.5	ODOR CONTROL (WASTEWATER TREATMENT)	80
2.6	CHAPTER REVIEW QUESTIONS	81
	REFERENCES AND RECOMMENDED READING	82
CHAPTER 3 BLUEPRINT READING		83
3.1	BLUEPRINTS: THE UNIVERSAL LANGUAGE	84
3.1.1	BLUEPRINT STANDARDS	86
3.1.1.1	STANDARDS-SETTING ORGANIZATIONS	86
3.1.1.2	ANSI STANDARDS FOR BLUEPRINT SHEETS	87
3.1.2	FINDING INFORMATION	87
3.1.2.1	DETAIL DRAWINGS	87
3.1.2.2	ASSEMBLY DRAWINGS	88
3.1.2.3	TITLE BLOCK	88
3.1.2.4	DRAWING NOTES	92
3.2	UNITS OF MEASUREMENT	97
3.2.1	FRACTIONS AND DECIMAL FRACTIONS	97
3.3	ALPHABET OF LINES	99
3.3.1	JUST A BUNCH OF DRAWN LINES?	100
3.3.2	VISIBLE LINES	100
3.3.3	HIDDEN LINES	101
3.3.4	SECTION LINES	101
3.3.5	CENTER LINES	101
3.3.6	DIMENSION AND EXTENSION LINES	101
3.3.7	LEADERS	103
3.3.8	CUTTING PLANE OR VIEWING PLANE LINES	103
3.3.9	BREAK LINES	104
3.3.10	PHANTOM LINES	104
3.3.11	LINE GAUGE	106
3.3.12	VIEWS	106
3.3.12.1	ORTHOGRAPHIC PROJECTIONS	106
3.3.12.2	ONE-VIEW DRAWINGS	108
3.3.12.3	TWO-VIEW DRAWINGS	109
3.3.12.4	THREE-VIEW DRAWINGS	111
3.3.12.5	AUXILIARY VIEWS	113
3.4	DIMENSION AND SHOP NOTES	113
3.4.1	DIMENSIONING	114
3.4.2	DECIMAL AND SIZE DIMENSIONS	115

3.4.3	DEFINITION OF DIMENSIONING TERMS	115
3.4.3.1	NOMINAL SIZE	116
3.4.3.2	BASIC SIZE	117
3.4.3.3	ALLOWANCE	117
3.4.3.4	DESIGN SIZE	117
3.4.3.5	LIMITS	118
3.4.3.6	TOLERANCE	118
3.4.3.7	DATUM	119
3.4.4	TYPES OF DIMENSIONS	119
3.4.4.1	LINEAR DIMENSIONS	119
3.4.4.2	ANGULAR DIMENSIONS	120
3.4.4.3	REFERENCE DIMENSIONS	121
3.4.4.4	TABULAR DIMENSIONS	121
3.4.4.5	ARROWLESS DIMENSIONS	122
3.4.5	SHOP NOTES	122
3.5	MACHINE DRAWINGS	122
3.5.1	THE CENTRIFUGAL PUMP DRAWING (SIMPLIFIED)	123
3.5.1.1	THE CENTRIFUGAL PUMP	123
3.5.1.2	CENTRIFUGAL PUMP: DESCRIPTION	124
3.5.1.3	CENTRIFUGAL PUMP: COMPONENTS	124
3.5.2	PACKING GLAND DRAWING	125
3.5.3	SUBMERSIBLE PUMP DRAWING (SIMPLIFIED)	126
3.5.4	TURBINE PUMP DRAWING (SIMPLIFIED)	126
3.6	SHEET METAL DRAWINGS	127
3.6.1	SHEET METAL	128
3.6.1.1	DIMENSION CALCULATIONS	128
3.6.1.2	CALCULATIONS FOR ALLOWANCES IN BEND	129
3.6.1.3	SET-BACK TABLE	129
3.6.1.4	FORMULAE USED TO DETERMINE DEVELOPED LENGTH	130
3.6.2	HEMS AND JOINTS	131
3.7	HYDRAULIC AND PNEUMATIC DRAWINGS	131
3.7.1	STANDARD HYDRAULIC SYSTEM	132
3.7.2	STANDARD PNEUMATIC SYSTEM	132
3.7.3	HYDRAULIC AND PNEUMATIC SYSTEMS: SIMILARITIES AND DIFFERENCES	133
3.7.4	TYPES OF HYDRAULIC AND PNEUMATIC DRAWINGS	133
3.7.5	GRAPHIC SYMBOLS FOR FLUID POWER SYSTEMS	133
3.7.5.1	SYMBOLS FOR METHODS OF OPERATION (CONTROLS)	134
3.7.5.2	SYMBOLS FOR ROTARY DEVICES	134
3.7.5.3	SYMBOLS FOR LINES	136
3.7.5.4	SYMBOLS FOR VALVES	136
3.7.5.5	SYMBOLS FOR MISCELLANEOUS UNITS	136
3.7.6	SUPPLEMENTARY INFORMATION ACCOMPANYING GRAPHIC DRAWINGS	137
3.7.6.1	SEQUENCE OF OPERATIONS	137
3.7.6.2	SOLENOID CHART	138
3.7.6.3	BILL OF MATERIALS	138

3.8	WELDING BLUEPRINTS AND SYMBOLS	138
3.8.1	WELDING PROCESSES	139
3.8.2	TYPES OF WELDED JOINTS	139
3.8.2.1	BUTT JOINTS	140
3.8.2.2	LAP JOINTS	140
3.8.2.3	TEE JOINTS	140
3.8.2.4	EDGE JOINTS	140
3.8.2.5	CORNER JOINTS	140
3.8.3	BASIC WELD SYMBOLS	141
3.8.3.1	SYMBOLS FOR ARC AND GAS WELDS	141
3.8.3.2	SYMBOLS FOR RESISTANCE WELDS	141
3.8.3.3	SYMBOLS FOR SUPPLEMENTARY WELDS	142
3.8.4	THE WELDING SYMBOL	142
3.8.4.1	REFERENCE LINE	143
3.8.4.2	ARROWHEAD	143
3.8.4.3	WELD SYMBOL	144
3.8.4.4	DIMENSIONS	144
3.8.4.5	SPECIAL SYMBOLS	144
3.8.4.6	CONTOUR SYMBOL	145
3.8.4.7	GROOVE ANGLE	145
3.8.4.8	SPOT WELDS	145
3.8.4.9	WELD-ALL-AROUND	145
3.8.4.10	FIELD WELD	146
3.8.4.11	MELT-THRU WELDS	146
3.8.4.12	FINISH SYMBOLS	146
3.8.4.13	TAIL	146
3.9	ELECTRICITY AND ELECTRICAL DRAWINGS	146
3.9.1	TROUBLESHOOTING AND ELECTRICAL DRAWINGS	147
3.9.2	ELECTRICAL SYMBOLS	147
3.9.3	ELECTRICAL VOLTAGE AND POWER	148
3.9.3.1	WHAT IS VOLTAGE?	148
3.9.3.2	HOW IS VOLTAGE PRODUCED?	148
3.9.3.3	HOW IS ELECTRICITY DELIVERED TO THE PLANT?	148
3.9.3.4	ELECTRIC POWER	149
3.9.4	TYPES OF ELECTRICAL DRAWINGS	149
3.9.4.1	ARCHITECTURAL DRAWINGS	149
3.9.4.2	CIRCUIT DRAWINGS	149
3.9.4.3	LADDER DRAWING	151
3.10	REFRIGERATION AND AIR CONDITIONING DRAWINGS	152
3.10.1	REFRIGERATION	153
3.10.1.1	BASIC PRINCIPLES OF REFRIGERATION	153
3.10.1.2	REFRIGERATION SYSTEM COMPONENTS	154
3.10.1.3	REFRIGERATION SYSTEM OPERATION	154
3.10.1.4	USING REFRIGERATION DRAWINGS IN TROUBLESHOOTING	155
3.10.1.5	REFRIGERATION COMPONENT DRAWINGS	156

3.10.2	AIR CONDITIONING	156
3.10.2.1	OPERATION OF A SIMPLE AIR CONDITIONING SYSTEM	157
3.10.2.2	DESIGN OF AIR CONDITIONING SYSTEMS	157
3.10.2.3	AIR CONDITIONING DRAWINGS	158
3.11	SCHEMATICS AND SYMBOLS	158
3.11.1	HOW TO USE SCHEMATIC DIAGRAMS	159
3.11.2	SCHEMATIC CIRCUIT LAYOUT	161
3.11.3	SCHEMATIC SYMBOLS	162
3.11.3.1	LINES ON A SCHEMATIC.	162
3.11.3.2	LINES CONNECT SYMBOLS	162
3.11.4	SCHEMATIC DIAGRAM: AN EXAMPLE.	163
3.11.4.1	A SCHEMATIC BY ANY OTHER NAME IS A LINE DIAGRAM	164
3.11.5	SCHEMATICS AND TROUBLESHOOTING.	165
3.12	ELECTRICAL SCHEMATICS	166
3.12.1	ELECTRICAL SYMBOLS	167
3.12.1.1	SCHEMATIC LINES	167
3.12.1.2	POWER SUPPLIES: ELECTRICAL SYSTEMS	168
3.12.1.3	POWER SUPPLIES: ELECTRONICS	169
3.12.1.4	ELECTRICAL LOADS	171
3.12.1.5	SWITCHES	172
3.12.1.6	INDUCTORS (COILS)	172
3.12.1.7	TRANSFORMERS	172
3.12.1.8	FUSES.	173
3.12.1.9	CIRCUIT BREAKERS	173
3.12.1.10	ELECTRICAL CONTACTS	174
3.12.1.11	RESISTORS	174
3.12.2	READING PLANT SCHEMATICS.	174
3.13	GENERAL PIPING SYSTEMS AND SYSTEM SCHEMATICS.	178
3.13.1	PIPING SYSTEMS.	179
3.13.2	IDENTIFYING PIPING SYMBOLS	179
3.13.3	PIPING JOINTS	179
3.13.3.1	SCREWED JOINTS	180
3.13.3.2	WELDED JOINTS	180
3.13.3.3	FLANGED JOINTS.	180
3.13.3.4	BELL-AND-SPIGOT JOINTS.	180
3.13.3.5	SOLDERED JOINTS	181
3.13.3.6	SYMBOLS FOR JOINTS AND FITTINGS	181
3.13.4	VALVES	181
3.13.4.1	VALVES: DEFINITION AND FUNCTION.	181
3.13.4.2	VALVE CONSTRUCTION	183
3.13.4.3	TYPES OF VALVES	184
3.14	HYDRAULIC AND PNEUMATIC SYSTEM SCHEMATIC SYMBOLS.	187
3.14.1	FLUID POWER SYSTEMS.	187
3.14.2	SYMBOLS USED FOR HYDRAULIC AND PNEUMATIC COMPONENTS	188

3.14.3	AC&R SYSTEM SCHEMATIC SYMBOLS	188
3.14.4	SCHEMATIC SYMBOLS USED IN REFRIGERATION SYSTEMS	189
3.14.4.1	REFRIGERATION PIPING SYMBOLS	189
3.14.4.2	REFRIGERATION FITTINGS SYMBOLS	189
3.14.4.3	REFRIGERATION VALVE SYMBOLS	190
3.14.4.4	REFRIGERATION ACCESSORY SYMBOLS	190
3.14.4.5	REFRIGERATION COMPONENT SYMBOLS	190
3.14.4.6	SCHEMATIC SYMBOLS USED IN AC&R AIR-DISTRIBUTION SYSTEM	191
3.15	CHAPTER REVIEW QUESTIONS	192
	REFERENCES AND RECOMMENDED READING	194

CHAPTER 4 ADVANCED WASTEWATER TREATMENT 197

4.1	INTRODUCTION	197
4.2	CHEMICAL TREATMENT	198
4.2.1	OPERATIONAL CONSIDERATIONS	199
4.3	MICROSCREENING	200
4.3.1	OPERATIONAL CONSIDERATIONS	200
4.4	FILTRATION	201
4.4.1	FILTRATION PROCESS DESCRIPTION	201
4.4.2	OPERATIONAL CONSIDERATIONS	201
4.5	BIOLOGICAL NITRIFICATION	203
4.5.1	OPERATIONAL CONSIDERATIONS	204
4.6	BIOLOGICAL DENITRIFICATION	205
4.6.1	OPERATIONAL CONSIDERATIONS	205
4.7	CARBON ADSORPTION	206
4.7.1	OPERATIONAL CONSIDERATIONS	206
4.8	LAND APPLICATION	207
4.8.1	TYPES AND MODES OF LAND APPLICATION	207
4.8.2	OPERATIONAL CONSIDERATIONS	209
4.9	BIOLOGICAL NUTRIENT REMOVAL	211
4.10	ENHANCED BIOLOGICAL NUTRIENT REMOVAL	211
4.10.1	0.5-MGD CAPACITY PLANT	212
4.10.2	1.5-MGD CAPACITY PLANT	212
4.10.3	1.55-MGD CAPACITY PLANT	213
4.10.4	2-MGD CAPACITY PLANT	213
4.10.5	2.6-MGD CAPACITY PLANT	213
4.10.6	3-MGD CAPACITY PLANT	214
4.10.7	4.8-MGD CAPACITY PLANT	214
4.10.8	24-MGD CAPACITY PLANT	214
4.10.9	39-MGD CAPACITY PLANT	215
4.10.10	42-MGD CAPACITY PLANT	215
4.10.11	54-MGD CAPACITY PLANT	216
4.10.12	67-MGD CAPACITY PLANT	216
	REFERENCE AND RECOMMENDED READING	216

CHAPTER 5	ADVANCED WASTEWATER CALCULATIONS	217
5.1	INTRODUCTION	217
5.2	WASTEWATER COLLECTION AND PRELIMINARY TREATMENT	217
5.2.1	WET-WELL PUMPING RATE	218
5.2.2	SCREENINGS REMOVED	219
5.2.3	SCREENING PIT CAPACITY	219
5.2.4	GRIT CHANNEL VELOCITY	220
5.2.5	GRIT REMOVAL	220
5.2.6	PLANT LOADINGS	221
5.3	SEDIMENTATION	222
5.3.1	PRIMARY TREATMENT	222
5.3.2	WEIR OVERFLOW RATE	223
5.3.3	SURFACE OVERFLOW RATE	223
5.3.4	SOLIDS LOADING RATE	223
5.3.5	BOD AND SS REMOVED (LB/DAY)	224
5.3.6	UNIT PROCESS EFFICIENCY CALCULATIONS	224
5.3.7	GENERAL SEDIMENTATION CALCULATIONS	225
5.4	TRICKLING FILTERS	226
5.4.1	HYDRAULIC LOADING RATE	226
5.4.2	ORGANIC LOADING RATE	226
5.4.3	BOD AND SS REMOVED (LB/DAYS)	226
5.4.4	UNIT PROCESS OR OVERALL EFFICIENCY	227
5.4.5	RECIRCULATION RATIO	227
5.4.6	GENERAL TRICKLING FILTER CALCULATIONS	227
5.5	ROTATING BIOLOGICAL CONTACTORS	229
5.5.1	HYDRAULIC LOADING RATE	229
5.5.2	SOLUBLE BOD	230
5.5.3	ORGANIC LOADING RATE	230
5.5.4	GENERAL RBC CALCULATIONS	230
5.6	ACTIVATED SLUDGE	231
5.6.1	AERATION TANK, SECONDARY CLARIFIER AND OXIDATION DITCH VOLUME	231
5.6.2	BOD OR COD LOADING (LB/DAY)	232
5.6.3	AERATION TANK: SOLIDS INVENTORY	232
5.6.4	FOOD-TO-MICROORGANISM (F/M) RATIO	232
5.6.5	SLUDGE AGE	233
5.6.6	SOLIDS RETENTION TIME	233
5.6.7	RETURN SLUDGE RATE	234
5.6.8	WASTING RATE	235
5.6.9	WASTE ACTIVATED SLUDGE PUMPING RATE	235
5.6.10	OXIDATION DITCH DETENTION TIME	236
5.6.11	GENERAL ACTIVATED SLUDGE CALCULATIONS	236
5.7	WASTE TREATMENT PONDS	239
5.7.1	BOD LOADING	239
5.7.2	ORGANIC LOADING RATE	239
5.7.3	BOD REMOVAL EFFICIENCY	239

5.7.4	HYDRAULIC LOADING RATE	240
5.7.5	POPULATION LOADING AND POPULATION EQUIVALENT	240
5.7.6	DETENTION TIME	240
5.7.7	GENERAL WASTE TREATMENT POND CALCULATIONS	240
5.8	CHEMICAL DOSAGE	242
5.8.1	FULL-STRENGTH CHEMICAL FEED RATE	242
5.8.2	CHLORINE DOSE, DEMAND, AND RESIDUAL	242
5.8.3	PERCENT STRENGTH OF SOLUTIONS	243
5.8.4	MIXING SOLUTIONS OF DIFFERENT STRENGTH	243
5.8.5	SOLUTION CHEMICAL FEEDER SETTING (GPD)	243
5.8.6	SOLUTION CHEMICAL FEEDER SETTING (ML/MIN)	244
5.8.7	DRY CHEMICAL FEEDER CALIBRATION	244
5.8.8	SOLUTION CHEMICAL FEEDER CALIBRATION	245
5.8.9	SOLUTION CHEMICAL FEEDER CALIBRATION (BASED ON DROP IN SOLUTION TANK LEVEL)	245
5.8.10	AVERAGE USE CALCULATIONS	246
5.8.11	GENERAL CHEMICAL DOSAGE CALCULATIONS	246
5.9	SLUDGE PRODUCTION AND THICKENING	248
5.9.1	PRIMARY AND SECONDARY CLARIFIER SOLIDS PRODUCTION	248
5.9.2	PERCENT SOLIDS AND SLUDGE PUMPING	248
5.9.3	GRAVITY THICKENING	249
5.9.4	DISSOLVED AIR FLOTATION (DAF) THICKENING	251
5.9.5	CENTRIFUGE THICKENING	252
5.9.6	GENERAL SLUDGE PRODUCTION AND THICKENING CALCULATIONS	253
5.10	DIGESTION	255
5.10.1	MIXING DIFFERENT SLUDGE MIXTURES	255
5.10.2	SLUDGE VOLUME PUMPED	256
5.10.3	SLUDGE PUMP OPERATING TIME	256
5.10.4	VOLATILE SOLIDS TO THE DIGESTER	257
5.10.5	SEED SLUDGE CALCULATION	257
5.10.6	DIGESTER LOADING RATE	258
5.10.7	STORED DIGESTER SLUDGE	258
5.10.8	VOLATILE ACIDS/ALKALINITY RATIO	259
5.10.9	LIME NEUTRALIZATION	259
5.10.10	PERCENT VOLATILE SOLIDS REDUCTION	260
5.10.11	VOLATILE SOLIDS DESTROYED	260
5.10.12	DIGESTER GAS PRODUCTION	260
5.10.13	DIGESTION TIME	261
5.10.14	AIR SUPPLY REQUIREMENTS	261
5.10.15	pH ADJUSTMENTS	262
5.10.16	GENERAL DIGESTER CALCULATIONS	262
5.11	SLUDGE DEWATERING	265
5.11.1	FILTER PRESS DEWATERING	265
5.11.2	BELT FILTER PRESS DEWATERING	266
5.11.3	VACUUM FILTER DEWATERING	266
5.11.4	SAND DRYING BED CALCULATIONS	267

5.11.5	COMPOSTING	267
5.11.6	GENERAL SLUDGE DEWATERING CALCULATIONS	268
	REFERENCES AND RECOMMENDED READING	270
CHAPTER 6 COMPREHENSIVE PRACTICE EXAM		271
6.1	INTRODUCTION	271
6.2	COMPREHENSIVE PRACTICE EXAM	272
	REFERENCES AND RECOMMENDED READING	276
APPENDIX A ANSWERS TO CHAPTER REVIEW QUESTIONS		277
	CHAPTER 1 ANSWERS	277
	CHAPTER 2 ANSWERS	277
	CHAPTER 3 ANSWERS	278
	CHAPTER 5 ANSWERS	280
	CHAPTER 6 ANSWERS	328
APPENDIX B FORMULAE		333
	AREA (FT ²)	333
	RECTANGULAR TANK	333
	CIRCULAR TANK	333
	VOLUME (FT ³)	333
	RECTANGULAR TANK	333
	CIRCULAR TANK	333
	FLOW (CFS)	333
	DOSE	334
	EFFICIENCY (% REMOVAL)	334
	WEIR LOADING (OVERFLOW RATE)	334
	SURFACE SETTLING RATE	334
INDEX		335

PREFACE, 2ND EDITION

Hailed on first publication as a straightforward, practical, and to-the-point account of wastewater principles, practices, and operations for general readers, students, and wastewater operators in training and for all levels of operators at any level of licensure, the second edition of *Spellman's Standard Handbook for Wastewater Operators*, Volumes I, II, and III, continues to deal with the important aspects of wastewater operations and operator preparation for licensure examinations. In addition, based on constructive and helpful criticism of the original series, each volume has been upgraded, updated, and expanded to include additional pertinent information to help the user attain success by better preparing each qualified user for professional licensure.

Spellman's Standard Handbook for Wastewater Operators is more than just a three-volume study guide or readily accessible source of information for review when preparing wastewater personnel for operator certification and licensure. Instead, this three-volume handbook is a resource manual and troubleshooting guide that contains a compilation of wastewater treatment information, data, operation material, process control procedures and problem solving, safety and health information, new trends in wastewater treatment administration and technology, and numerous sample problem-solving practice sets. The most important aspects of the text are threefold:

1. It gives today's wastewater operators instant information they need to expand their knowledge—which aids them in the efficient operation of a wastewater treatment plant.
2. It provides the user with the basic information and sample problem-solving sets required to prepare for state licensing and certification examinations.
3. It provides user-friendly, straightforward, plain-English fundamental reference material and unit process troubleshooting guidance required on a daily basis not only by the plant manager, plant superintendent, chief operator, lab technician, and maintenance operator but also, more importantly, by the plant operator.

We could say that the primary goal of the handbook is to enhance the understanding, awareness, and abilities of practicing operators and those who aspire to be operators. The first volume (introductory), second volume (intermediate), and third volume (advanced) are designed to build on one another, providing increasingly advanced information.

The message of this handbook has not changed: None of us is chained to the knowledge we already have—we should strive to increase our technical knowledge and expertise constantly. For those preparing for operator licensing, this is critical, as wastewater treatment is a complex process. For those seasoned, licensed veteran operators, continuous review is also critical, because wastewater treatment is still an evolving, dynamic, ever-changing field. This handbook series (which we think of as “answer books”) provides the means for reaching these goals.

Contrary to popular belief (and simply put), treating wastewater is not just an art but both an art and a science. Treating wastewater successfully demands technical expertise, experience, and a broad range of available technologies, as well as an appreciation for and understanding of the fundamental environmental and health reasons for the processes involved. It demands unique vision and capabilities. This is where *Spellman's Standard Handbook for Wastewater Operators* comes in. From pumping and screening influent and treating the wastestream through managing biosolids, this handbook series provides easy-to-understand, state-of-the-art information beginning at the fundamental level for those preparing for the Class IV/III or Grade I/II operator examination, proceeds to the intermediate level for the Class III/II or Grade II/III operator examination, and finishes at the advanced level for the Class I/Grade IV/V wastewater operator license examination. Though the information in these volumes is aimed at three separate levels (fundamental, intermediate, and advanced), overlap between each volume ensures continuity and a smooth read from volume to volume. In essence, each volume is a reference text that enables the practitioner of the artful science of wastewater treatment to qualify for certification or refresh his or her memory in an easy, precise, efficient, effective manner.

This handbook was prepared to help operators obtain licensing and operate wastewater treatment plants properly. It can also be used as a textbook in technical training courses in technical schools and at the junior college level. Note that the handbook does not discuss the specific content of the examination. It reviews the wastewater operator's job-related knowledge identified by the examination developers as essential for a minimally competent Class IV through Class I or Grade I through Grade V wastewater treatment plant operator. Every attempt has been made to make the handbook as comprehensive as possible while maintaining its compact, practical format.

The bottom line: The handbook is not designed to simply teach the operator licensing exams, although it is immediately obvious to the users that the material presented will help them pass licensing exams. The material in each volume is intended for practical use and application. Applied math and chemistry are presented by way of real-world problems, and readers will learn how to maintain equipment. Apparatus used in the laboratory and in the field (e.g., valves and pumps) is also covered. Will the handbook series help the reader obtain a passing score on certification exams? Yes. If you follow it, use it, and reuse it, it will help—and that is the real bottom line.

Frank R. Spellman
Norfolk, Va.

ABOUT THE AUTHOR



Frank R. Spellman, PhD, is a retired assistant professor of environmental health at Old Dominion University, Norfolk, Virginia, and author of more than 65 books covering topics ranging from concentrated animal feeding operations (CAFOs) to all areas of environmental science and occupational health. Many of his texts are readily available online, and several have been adopted for classroom use at major universities throughout the United States, Canada, Europe, and Russia; two are currently being translated into Spanish for South American

markets. Dr. Spellman has been cited in more than 400 publications. He serves as a professional expert witness for three law groups and as an incident/accident investigator for the U.S. Department of Justice and a northern Virginia law firm. In addition, he consults on homeland security vulnerability assessments for critical infrastructure including water/wastewater facilities nationwide and conducts pre-Occupational Safety and Health Administration (OSHA)/Environmental Protection Agency (EPA) audits throughout the country. Dr. Spellman receives frequent requests to co-author with well-recognized experts in several scientific fields; for example, he is a contributing author for the prestigious text *The Engineering Handbook*, 2nd ed. (CRC Press). Dr. Spellman lectures on sewage treatment, water treatment, and homeland security and health and safety topics throughout the country and teaches water/wastewater operator short courses at Virginia Tech (Blacksburg, Virginia). He holds a BA in public administration, a BS in business management, an MBA, an MS in environmental engineering, and a PhD in environmental engineering.

WATER ECOLOGY

Streams are the arteries of Earth, beginning in capillary creeks, brooks, and rivulets. No matter the source, they move in only one direction—downhill, as the heavy hand of gravity tugs and drags the stream toward the sea. During its inexorable flow downward, now and then there is an abrupt change in geology. Boulders are mowed down by “slumping” (gravity) from their “in place” points high up on canyon walls.

As stream flow grinds, chisels, and sculpts the landscape, the effort is increased by momentum, augmented by turbulence provided by rapids, cataracts, and waterfalls. These falling waters always hypnotize us, like fire gazing or wave watching.

Before emptying into the sea, streams often pause, forming lakes. When one stares into a healthy lake, its phantom blue-green eye stares right back. Only for a moment—relatively speaking, of course, because all lakes are ephemeral, doomed. Eventually the phantom blue-green eye is close lidded by the moist verdant green of landfill.

For water that escapes the temporary bounds of a lake, most of it evaporates or moves on to the gigantic sink—the sea—where the cycle continues, forever more it is hoped.

1.1 INTRODUCTION

The “control of nature” is a phrase conceived in arrogance, born of the Neanderthal age of biology and the convenience of man.

Rachel Carson (1962)

What is ecology? Why is ecology important? Why study ecology? These are all simple, straightforward questions; however, providing simple, straightforward answers is not that easy. Notwithstanding the inherent difficulty of explaining any complex science in simple, straightforward terms, that is the purpose, the goal, the mission of this text. In short, the task of this text is to outline basic information that explains the functions and values of ecology and its interrelationships with other sciences, including the direct impact of ecology on our lives. In doing so, the author hopes not only to dispel the common misconception that ecology is too difficult for the average person to understand but also to instill the concept of ecology as an asset that can be learned and cherished.

1.2 WHAT IS ECOLOGY?

Ecology can be defined in various and numerous ways. Ecology, or ecological science, is commonly defined in the literature as the scientific study of the distribution and abundance of living organisms and how the distribution and abundance are affected by interactions between the organisms and their environment. The term *ecology* was coined in 1866 by the German biologist Haeckel, and it loosely means “the study of the household [of nature].” Odum (1983) suggested that the term is derived from the Greek *oikos*, meaning home. Ecology, then, means the study of organisms at home. It means the study of an organism in its home. Ecology is the study of the relation of an organism or a group of organisms to their environment. In a broader sense, ecology is the study of the relation of organisms or groups to their environment.

Note: No ecosystem can be studied in isolation. If we were to describe ourselves, our histories, and what made us the way we are, we could not leave the world around us out of our description! So it is with streams: They are directly tied in with the world around them. They take their chemistry from the rocks and dirt beneath them as well as from a great distance around them (Spellman, 1996).

Charles Darwin explained ecology in a famous passage in the *On the Origin of Species*, originally published in 1859 (Darwin, 1998), that helped establish the science of ecology. According to Darwin, a “web of complex relations” binds all living things in any region. Adding or subtracting even a single species causes waves of change that race through the web, “onwards in ever-increasing circles of complexity.” The simple act of adding cats to an English village would reduce the number of field mice. The reduced number of mice would benefit bumblebees, whose nests and honeycombs the mice often devour. Increasing the number of bumblebees would benefit the heartsease and red clover, which are fertilized almost exclusively by bumblebees. So, adding cats to the village could end by adding flowers. For Darwin, the whole of the Galapagos archipelago argues this fundamental lesson. The volcanoes are much more diverse in their ecology than their biology. The contrast suggests that, in the struggle for existence, species are shaped at least as much by the local flora and fauna as by the local soil and climate. “Why else would the plants and animals differ radically among islands that have the same geological nature, the same height, and climate?” (Darwin, 1998).

Probably the best way to understand ecology—to get a really good feel for it or to get to the heart of what ecology is all about—is to read the following:

We poison the caddis flies in a stream and the salmon runs dwindle and die. We poison the gnats in a lake and the poison travels from link to link of the food chain and soon the birds of the lake margins become victims. We spray our elms and the following springs are silent of robin song, not because we sprayed the robins directly but because the poison traveled, step by step, through the now familiar elm leaf–earthworm–robin cycle. These are matters of record, observable, part of the visible world around us. They reflect the web of life—or death—that scientists know as ecology.

Rachel Carson (1962)

As Carson pointed out, what we do to any part of our environment has an impact on other parts. In other words, there is an interrelationship between the parts that make up our environment. Probably the best way to state this interrelationship is to define ecology definitively—that is, to define it as it is used in this text: “Ecology is the science that deals with the specific interactions that exist between organisms and their living and nonliving environment” (Tomera, 1989).

When environment was mentioned in the proceeding and as it is discussed throughout this text, it (the environment) includes everything important to the organism in its surroundings. The organism’s environment can be divided into four parts:

1. Habitat and distribution (its place to live)
2. Other organisms (e.g., friendly or hostile)
3. Food
4. Weather (e.g., light, moisture, temperature, soil)

The four major subdivisions of ecology are:

1. Behavioral ecology
2. Population ecology (autecology)
3. Community ecology (synecology)
4. Ecosystem ecology

Behavioral ecology is the study of the ecological and evolutionary basis for animal behavior. **Population ecology (or autecology)** is the study of an individual organism or a species. It emphasizes life history, adaptations, and behavior. It is the study of communities, ecosystems, and the biosphere. An example of autecology would be when biologists study exclusively the ecology of the salmon. **Community ecology (or synecology)**, on the other hand, is the study of groups of organisms associated together as a unit and deals with the environmental problems

Key Point: Ecology is generally categorized according to complexity, the primary kinds of organism under study (e.g., plant, animal, insect ecology), the biomes principally studied (e.g., forest, desert, benthic, grassland), the climatic or geographic area (e.g., arctic or tropics), and the spatial scale (macro or micro) under consideration.

caused by mankind; for example, the effect of discharging phosphorus-laden effluent into a stream involves several organisms. The activities of human beings have become a major component of many natural areas. As a result, it is important to realize that the study of ecology must involve people. *Ecosystem ecology* is the study of how energy flow and matter interact with biotic elements of ecosystems (Odum, 1971).

1.3 WHY IS ECOLOGY IMPORTANT?

Ecology, in its true sense, is a holistic discipline that does not dictate what is right or wrong. Instead, ecology is important to life on Earth simply because it makes us aware, to a certain degree, of what life on Earth is all about. Ecology shows us that each living organism has an ongoing and continual relationship with every other element that makes up our environment. Simply, ecology is all about interrelationships, intraspecific and interspecific, and on how important it is to maintain these relationships—to ensure our very survival.

At this point in this discussion, literally countless examples could be used to point out the importance of ecology and interrelationships; however, an excerpt from Peter Marshall's *Mr. Jones: Meet the Master* is provided here to demonstrate the importance of ecology as well as to point out that an ecological principle can be a double-edged sword, depending on one's point of view (ecological problems with pollution can be a judgment call; that is, they are a matter of opinion).

The Keeper of the Spring

This is the story of the keeper of the spring. He lived high in the Alps above an Austrian town and had been hired by the town council to clear debris from the mountain springs that fed the stream that flowed through the town. The man did his work well and the village prospered. Graceful swans floated in the stream. The surrounding countryside was irrigated. Several mills used the water for power. Restaurants flourished for townspeople and for a growing number of tourists.

Years went by. One evening at the town council meeting someone questioned the money being paid to the keeper of the spring. No one seemed to know who he was or even if he was still on the job high up in the mountains. Before the evening was over, the council decided to dispense with the old man's services.

Weeks went by and nothing seemed to change. Then autumn came. The trees began to shed their leaves. Branches broke and fell into the pools high up in the mountains. Down below the villagers began to notice the water becoming darker. A foul odor appeared. The swans disappeared. Also, the tourists. Soon disease spread through the town.

When the town council reassembled, they realized that they had made a costly error. They found the old keeper of the spring and hired him back again. Within a few weeks, the stream cleared up and life returned to the village as they had known it before.

Marshall (1950)

After reviewing Marshall's parable about restoration of the spring, the average person might think, "Gee, all is well with the town again." Because of their swans, irrigation, hydropower, and pretty views, the residents seem to be pleased that the stream was restored to its "normal" state. The trained ecologist, however, would take a different view of this same stream. The ecologist would go beyond the hype (as portrayed in the popular media, including literature) about what a healthy stream is. The trained ecologist would know that a perfectly clean stream, clear of all terrestrial plant debris (woody debris and leaves) would not be conducive to ensuring a diverse, productive population of invertebrates and fish, would not preserve natural sediment and water regimes, and would not ensure overall stream health (Dolloff and Webster, 2000).

1.4 WHY STUDY ECOLOGY?

Does anyone really need to be an ecologist or a student of ecology to appreciate the following words of Will Carleton (1845–1912) from his classic poem *Autumn Days*?

Sweet and smiling are thy ways,
Beauteous, gold Autumn days.

Moreover, does anyone need to study ecology to observe, to relish, to feel, to sense the real thing—nature's annual color palette in full kaleidoscopic display—when the "yellow, mellow, ripened days are sheltered in a golden coating?" It is those clear and sunny days and cool and crisp nights of autumn that provide an almost irresistible lure to those of us (ecologist and nonecologist alike) who enjoy the outdoors. To take in the splendor and delight of autumn's color display, many head for the hills, the mountains, countryside, lakes, streams, and recreation areas of our national forests. The more adventurous ride horseback or backpack through nature's glory and solitude on trails winding deep into forest tranquility—just being out of doors on these golden days rivals any other thrill in life. Even those of us fettered to the chains of city life are often exposed to city streets with columns of life ablaze in color.

No, one need not study ecology to witness, appreciate, and understand the enchantment of autumn's annual color display—summer extinguished in a blaze of color. It is a different story, however, for those involved in trying to understand all of the complicated actions—and even more complicated interactions—involving pigments, sunlight, moisture, chemicals, temperatures, site, hormones, length of daylight, genetic traits, and so on that make for a perfect autumn color display (USDA, 1999). This is the work of the ecologist—to probe deeper and deeper into the basics of nature, constantly seeking answers. To find the answers, the ecologist must be a synthesis scientist; that is, the ecologist must be well versed in botany, zoology, physiology, genetics, and other disciplines such as geology, physics, and chemistry.

Earlier, we used Marshall's parable to make the point that a clean stream and other downstream water bodies can be a good or a bad thing, depending on one's point of view, as pollution is a judgment call. The

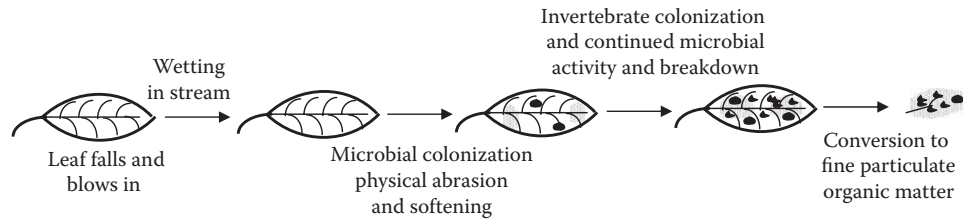

Figure 1.1 The processing, or conditioning, sequence for a deciduous tree leaf in a temperate stream. (Adapted from Allan, J.D., *Stream Ecology: Structure and Functions of Running Waters*, Chapman & Hall, New York, 1995, p. 114.)

stream ecologist, for example, knows that terrestrial plant debris is not only a good thing but is also absolutely necessary. Why? Consider the following explanation.

A stream has two possible sources of primary energy: (1) instream photosynthesis by algae, mosses, and higher aquatic plants, and (2) imported organic matter from streamside vegetation (e.g., leaves and other parts of vegetation). Simply put, a significant portion of the food that is eaten grows right in the stream, such as algae, diatoms, nymphs and larvae, and fish. This food that originates from within the stream is *autochthonous* (Benfield, 1996).

Most food in a stream, however, comes from outside the stream. This is especially the case in small, heavily wooded streams, where there is normally insufficient light to support substantial instream photosynthesis so energy pathways are supported largely by imported energy. A large portion of this imported energy is provided by leaves. Worms drown in floods and get washed in. Leafhoppers and caterpillars fall from trees. Adult mayflies and other insects mate above the stream, lay their eggs in it, and then die in it. All of this food from outside the stream is *allochthonous*.

1.4.1 Leaf Processing in Streams

Autumn leaves entering streams are nutrition poor because trees absorb most of the sugars and amino acids (nutrients) that were present in the green leaves (Suberkoop et al., 1976). Leaves falling into streams may be transported short distances but usually are caught by structures in the streambed to form leaf packs. These leaf packs are then processed in place by components of the stream communities in a series of well-documented steps (Figure 1.1) (Peterson and Cummins, 1974).

Within 24 to 48 hours of entering a stream, many of the remaining nutrients in leaves leach into the water. After leaching, leaves are composed mostly of structural materials, such as nondigestible cellulose and lignin. Within a few days, fungi (especially Hyphomycetes), protozoa, and bacteria process the leaves by microbial processing (Figure 1.1) (Barlocher and Kendrick, 1975). Two weeks later, microbial conditioning

leads to structural softening of the leaf and, among some species, fragmentation. Reduction in particle size from whole leaves (coarse particulate organic matter, or CPOM) to fine particulate organic matter (FPOM) is accomplished primarily through the feeding activities of a variety of aquatic invertebrates collectively known as *shredders* (Cummins, 1974; Cummins and Klug, 1979). Shredders (stoneflies, for example) help to produce fragments shredded from leaves but not ingested and fecal pellets, which reduce the particle size of organic matter. The particles are then collected (by mayflies, for example) and serve as a food resource for a variety of micro- and macroconsumers. Collectors eat what they want and send even smaller fragments downstream. These tiny fragments may be filtered out of the water by a true fly larva (i.e., a *filterer*). Leaves may also be fragmented by a combination of microbial activity and physical factors such as current and abrasion (Benfield et al., 1977; Paul et al., 1978).

Leaf-pack processing by all of the elements mentioned above (i.e., leaf species, microbial activity, physical and chemical features of the stream) is important; however, the most important point is that these integrated ecosystem processes convert whole leaves into fine particles that are then distributed downstream and used as an energy source by various consumers.

The bottom line on allochthonous material in a stream: Insects that have fallen into a stream are ready to eat and may join leaves, exuviae, copepods, dead and dying animals, rotifers, bacteria, dislodged algae, and immature insects in their float (drift) downstream to a waiting hungry mouth.

Another important reason to study and learn ecology can be garnered from another simple stream ecology example.

Family Picnic Hosts Insect Intruders

On one of their late August holiday outings, a family of 18 picnickers from a couple of small rural towns visited a local stream that coursed its way alongside or through their towns. This annual outing was looked upon with great anticipation for it was that one time each year when aunts, uncles, and cousins came together as one big family. The streamside setting was perfect for such an outing, but historically, until quite recently, the stream had been posted “DANGER—NO SWIMMING, CAMPING, or FISHING!”

Because the picnic area was such a popular location for picnickers, swimmers, and fishermen over the years, several complaints about the polluted stream were filed with the County Health Department. The Health Department finally took action to restore the stream to a relatively clean condition. Sanitation workers removed debris and old tires and plugged or diverted end-of-pipe industrial outfalls upstream of the picnic area. After a couple years of continuous stream clean-up and the stream's own natural self-purification process, the stream was given a clean bill of health by the Health Department.

When the stream had been declared clean and fit for use by swimmers and fishermen, the postings were removed, and it did not take long for the word to get out. Local folks and others alike made certain, at first opportunity, to flock to the restored picnic and swimming and fishing site alongside the stream. During most visits to the restored picnic area, visitors, campers, fishermen, and others were pleased with the cleaned-up surroundings. In late summer, however, when the family of 18 and several others visited the restored picnic area, they found themselves swarmed by thousands of speedy dragonflies and damselflies, especially near the bank of the stream. Soon they found the insects too much to deal with so they stayed clear of the stream. To themselves and to anyone who would listen, the same complaint was heard over and over again: “What happened to our nice stream? With all those nasty bugs the stream may as well be polluted again.” So, when August arrived with its hordes of dragonfly-type insects, the picnickers, campers, swimmers, and fishermen avoided the place and did not return until the insects departed.

One local family, though, did not avoid the picnic area in August; on the contrary, August became one of their favorite times to visit, camp, swim, take in nature, and fish, as they usually had most of the site to themselves. The family was accompanied by a local university professor of ecology who knew the truth about the area and the dragonflies and other insects. She knew that dragonflies and damselflies are macroinvertebrate indicator organisms; they only inhabit, grow, and thrive in and around streams that are clean and healthy—when dragonflies and damselflies are around, they indicate nonpolluted water. Further, the ecology professor knew that dragonflies are valued as predators, friends, and allies in the continual war against flies and in controlling populations of harmful insects such as mosquitoes. Dragonflies, on swiftest wings (25 to 35 mph), take the wrigglers in the water and the adults that are hovering over streams and ponds laying their eggs.

The ecology professor’s husband, an amateur poet, also understood the significance of the presence of the indicator insects and had no problem sharing the same area with them. He viewed the winged insects with the eye of a poet and was aware that poets through the years have lavished their attention on dragonflies and paid them delightful tributes. James Whitcomb Riley (1849–1916) wrote:

Till the dragon fly, in light
Gauzy armor, burnished bright,
Came tilting down the waters
In a wild, bewildered flight.

1.5 HISTORY OF ECOLOGY

The chronological development of most sciences is clear and direct. Listing the progressive stages in the development of biology, math, chemistry, and physics is a relatively easy, straightforward process. The science of ecology is different. Having only gained prominence in the latter part of the 20th century, ecology is generally spoken of as a new science;

however, ecological thinking at some level has been around for a long time, and the principles of ecology have developed gradually and more like a multistemmed bush than a tree with a single trunk (Smith, 1996).

Smith and Smith (2006) observed that one can argue that ecology can be traced back to Aristotle or perhaps his friend and associate, Theophrastus, both of whom had interest in the relations between organisms and the environment and in many species of animals. Theophrastus described interrelationships between animals and between animals and their environment as early as the 4th century B.C.E. (Ramalay, 1940).

Modern ecology has its early roots in plant geography (i.e., plant ecology, which developed earlier than animal ecology) and natural history. The early plant geographers (ecologists) included Carl Ludwig Willdenow (1765–1812) and Friedrich Alexander von Humboldt (1769–1859). Willdenow was one of the first phytogeographers; he was also a mentor to von Humboldt. Willdenow, for whom the perennial vine Willdenow's spikemoss (*Selaginella willdenowii*) is named, developed the notion, among many others, that plant distribution patterns changed over time. Von Humboldt, considered by many to be the father of ecology, further developed many of Willdenow's notions, including the notion that barriers to plant dispersion were not absolute.

Another scientist who is considered a founder of plant ecology was Johannes E.B. Warming (1841–1924). Warming studied the tropical vegetation of Brazil. He is best known for working on the relations between living plants and their surroundings. He is also recognized for his flagship text on plant ecology, *Plantesamfund* (1895). He also wrote *A Handbook of Systematic Botany* (1878).

Meanwhile, other naturalists were assuming important roles in the development of ecology. First and foremost among the naturalists was Charles Darwin. While working on his *On the Origin of Species*, Darwin came across the writings of Thomas Malthus (1766–1834), who advanced the principle that populations grow in a geometric fashion, doubling at regular intervals until they outstrip the food supply—ultimately resulting in death and thus restraining population growth (Smith and Smith, 2006). In his autobiography written in 1876, Darwin wrote:

In October 1838, that is, fifteen months after I had begun my systematic inquiry, I happened to read for amusement Malthus on *Population* and being well prepared to appreciate the struggle for existence which everywhere goes on from long-continued observation of the habits of animals and plants it at once struck me that under these circumstances favorable variations would tend to be preserved, and unfavorable ones to be destroyed. The results of this would be the formation of a new species. Here, then, I had at last got a theory by which to work.

During the period Darwin was formulating his theories regarding the origin of species, Gregor Mendel (1822–1884) was studying the transmission of characteristics from one generation of pea plants to another. The work of Mendel and Darwin provided the foundation for *population genetics*, the study of evolution and adaptation.

Time marched on, and the work of chemists such as Antoine-Laurent Lavoisier (who lost his head during the French Revolution) and Horace B. de Saussure, as well as the Austrian geologist Eduard Suess (who proposed the term *biosphere* in 1875) all set the foundations of the advanced work that followed.

Note: The Russian geologist Vladimir Vernadsky detailed the idea of a biosphere in 1926.

Several forward strides in animal ecology, independent of plant ecology, were made during the 19th century that enabled the 20th-century scientists R. Hesse, Charles Elton, Charles Adams, and Victor Shelford to refine the discipline.

Many early plant ecologists were “concerned with observing the patterns of organisms in nature, attempting to understand how patterns were formed and maintained by interactions with the physical environment” (Smith and Smith, 2006). Instead of looking for patterns, Frederic E. Clements (1874–1945) sought a system of organizing nature. Conducting his studies on vegetation in Nebraska, he postulated that the plant community behaves as a complex organism that grows and develops through stages, resembling the development of an individual organism to a mature (climax) stage. Clements’s theory of vegetation was roundly criticized by Arthur Tansley, a British ecologist, and others.

In 1935, Tansley coined the term *ecosystem*—the interactive system established between the group of living creatures (*biocoenosis*) and the environment in which they live (*biotype*). Tansley’s ecosystem concept was adopted by the well-known and influential biology educator Eugene P. Odum. Along with his brother, Howard Odum, E.P. Odum wrote a textbook that educated multiple generations of biologists and ecologists in North America (including the author of this text). E.P. Odum is often called the “father of modern ecosystem ecology.”

A new direction in ecology was given a boost in 1913 when Victor Shelford stressed the interrelationship of plants and animals. He conducted early studies on succession in the Indiana dunes and on experimental *physiological ecology*. Because of his work, ecology became a science of communities. His *Animal Communities in Temperate America* (written in 1913) was one of the first books to treat ecology as a separate science. E.P. Odum was one of Shelford’s students.

Human ecology began to be studied in the 1920s. At about the same time, the study of populations split into the two fields of *population ecology* and *evolutionary ecology*. Closely associated with population ecology and evolutionary ecology is *community ecology*. At the same time, *physiological ecology* arose. Later, natural history observations spawned *behavioral ecology* (Smith and Smith, 2006).

The history of ecology has been tied to advances in biology, physics, and chemistry that have spawned new areas of study in ecology, such as landscape, conservation, restoration, and global ecology. The study of ecology has been rife with conflicts and opposing camps. The

first major split in ecology was between plant ecology and animal ecology (Smith, 1996), which even led to a controversy over use of the term *ecology*. Botanists dropped the initial “o” from *oecology*, the spelling in use at the time, and zoologists refused to use the term at all, because of its perceived affiliation with botany. Other historical schisms involved organismal and individualist ecology, holism vs. reductionism, and theoretical vs. applied ecology (Ecology, 2007).

To illustrate one way in which the ecosystem classification is used, a real-world model developed by the U.S. Department of Agriculture is provided below (USDA, 2007).

1.5.1 Example Ecosystem: Agroecosystem Model

What are the basic components of agroecosystems? Just as natural ecosystems they can be thought of as including the processes of primary producing, consumption, and decomposition interacting with abiotic environmental components and resulting in energy flow and nutrient cycling. Economic, social, and environment factors must be added to this primary concept because of the human element that is so closely involved with agroecosystem creation and maintenance.

1.5.1.1 Agroecosystem Characteristics

Agricultural ecosystems (referred to as *agroecosystems*) have been described by Odum (1984) as domesticated ecosystems. He suggested that they are in many ways intermediate between natural ecosystems (such as grasslands and forests) and fabricated ecosystems (cities). Agroecosystems are solar powered (as are natural systems) but differ from natural systems in that:

1. Auxiliary energy sources are used to enhance productivity; these sources are processed fuels along with animal and human labor.
2. Species diversity is reduced by human management to maximize yield of specific foodstuffs (plant or animal).
3. Dominant plant and animal species are subject to artificial rather than natural selection.
4. Control is external and goal oriented rather than internal via sub-system feedback as in natural ecosystems.

Agroecosystems do not exist without human intervention in the landscape; therefore, creation of these ecosystems (and maintenance of them, as well) is necessarily concerned with the human economic goals of production, productivity, and conservation. Agroecosystems are controlled, by definition, by management of ecological processes.

Crossley et al. (1984) addressed the possible use of agroecosystem as a unifying and in many ways clarifying concept for proper management of managed landscape units. All ecosystems are open; that

is, they exchange biotic and abiotic elements with other ecosystems. Agroecosystems are extremely open—with major exports of primary and secondary production (plant and animal production) as well as increased opportunity for loss of nutrient elements. Because modern agroecosystems are entirely dependent on human intervention, they would not persist but for that intervention. It is for this reason that they are sometimes considered to be artificial systems rather than natural systems that do not require intervention to persist.

Definitions of agroecosystems often include the entire support base of energy and material subsidies, seeds, and chemicals, as well as a sociopolitical–economic matrix in which management decisions are made. Although this is logical, Crossley (1984) preferred to designate an individual field as an agroecosystem because it is consistent with designating an individual forest catchment or lake as an ecosystem. He envisioned the *farm system* as consisting of a set of agroecosystems—fields with similar or different crops—together with support mechanisms and socioeconomic factors contributing to their management. Agroecosystems retain most if not all of the functional properties of natural ecosystems—nutrient conservation mechanisms, energy storage and use patterns, and regulation of biotic diversity.

1.5.1.2 Ecosystem Pattern and Process

Throughout the United States the landscape consists of patches of natural ecosystems scattered (or imbedded) in a matrix of various agroecosystems and fabricated ecosystems. In fact, about three quarters of the land area of the United States is occupied by agroecosystems (USDA, 1982). The pattern created by this interspersion incorporates elements of the variability of structure and separation of functions among the various ecosystems. Pattern variables quantify the structure and relationships between systems; the process component implies functional relationships between and within the biotic and abiotic ecosystem components. Within-agroecosystems processes include:

- Enhanced productivity of producers through fertilization
- Improved productivity through selective breeding
- Management of pests with various control methods
- Management of various aspects of the hydrologic cycle
- Landforming

1.6 LEVELS OF ORGANIZATION

Odum (1983) suggested that the best way to delimit modern ecology is to consider the concept of *levels of organization*. Levels of organization can be simplified as shown in Figure 1.2. In this relationship, organs form an organism, organisms of a particular species form a population, and populations occupying a particular area form a community. Communities, interacting with nonliving or abiotic factors, separate in

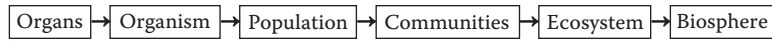

Figure 1.2 Levels of organization.

a natural unit to create a stable system known as the *ecosystem* (the major ecological unit), and the part of Earth in which the ecosystem operates is known as the *biosphere*. Tomera (1989) pointed out that every community is influenced by a particular set of abiotic factors. Inorganic substances such as oxygen and carbon dioxide, among others, and some organic substances represent the abiotic part of the ecosystem.

The physical and biological environment in which an organism lives is referred to as its *habitat*; for example, the habitat of two common aquatic insects, the backswimmer (*Notonecta*) and the water boatman (*Corixa*), is the littoral zone of ponds and lakes (shallow, vegetation-choked areas) (Figure 1.3). Within each level of organization of a particular habitat, each organism has a special role. The role the organism plays in the environment is referred to as its *niche*. A niche might be that the organism is food for some other organism or is a predator of other organisms. Odum (1975) referred to an organism's niche as its "profession." In other words, each organism has a job or role to fulfill in its environment. Although two different species might occupy the same habitat, niche separation based on food habits differentiates two species (Odum, 1983). Comparing the niches of the backswimmer and the water boatman reveals such niche separation. The backswimmer is an active predator, while the water boatman feeds largely on decaying vegetation (McCafferty, 1981).

1.7 ECOSYSTEMS

An *ecosystem* is an area that includes all organisms therein and their physical environment. The ecosystem is the major ecological unit in nature. Living organisms and their nonliving environment are inseparably interrelated and interact upon each other to create a self-regulating and self-maintaining system. To create a self-regulating and self-maintaining system, ecosystems are homeostatic; that is, they resist any change through natural controls. These natural controls are important in ecology. This is especially the case because it is people through their complex activities who tend to disrupt natural controls.

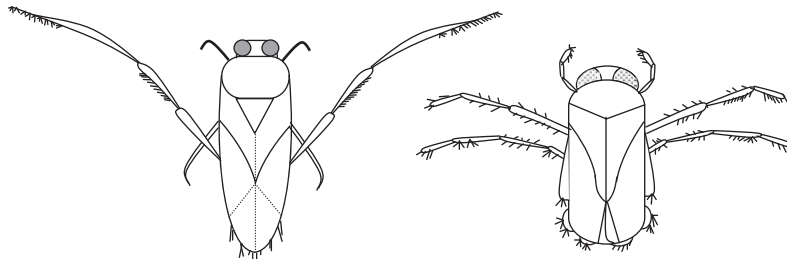

Figure 1.3 *Notonecta* (left) and *Corixa* (right). (Adapted from Odum, E.P., *Basic Ecology*, Saunders, Philadelphia, PA, 1983, p. 402.)

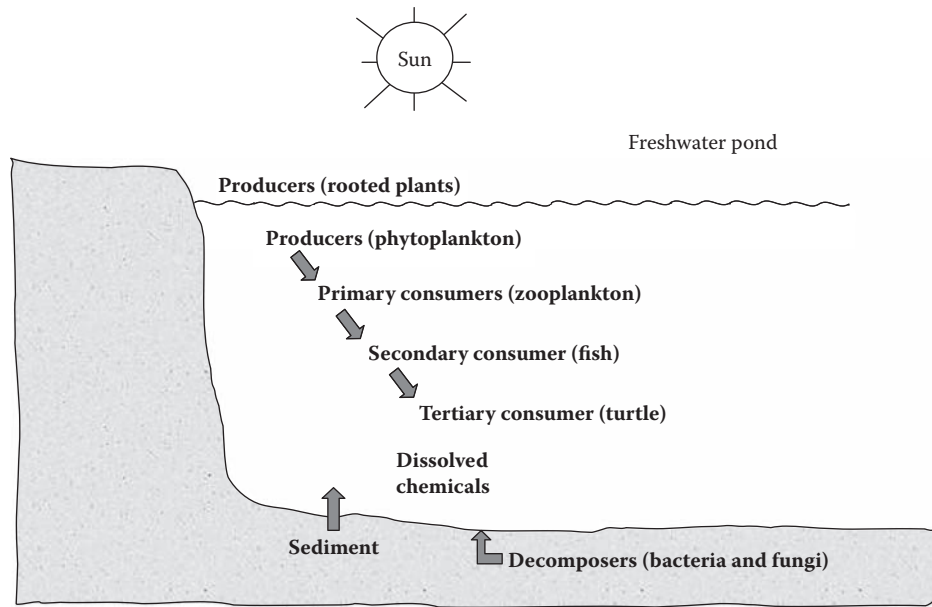

Figure 1.4 Major components of a freshwater pond ecosystem.

As stated earlier, the ecosystem encompasses both the living and nonliving factors in a particular environment. The living or biotic part of the ecosystem is formed by two components: *autotrophic* and *heterotrophic*. The autotrophic (self-nourishing) component does not require food from its environment but can manufacture food from inorganic substances; for example, some autotrophic components (plants) manufacture needed energy through photosynthesis. Heterotrophic components, on the other hand, depend on autotrophic components for food.

The nonliving or abiotic part of the ecosystem is formed by three components: inorganic substances, organic compounds (link biotic and abiotic parts), and climate regime. Figure 1.4 is a simplified diagram of a few of the living and nonliving components of an ecosystem found in a freshwater pond.

An ecosystem is a cyclic mechanism in which biotic and abiotic materials are constantly exchanged through *biogeochemical cycles*, where *bio* refers to living organisms; *geo* to water, air, rocks, or solids; and *chemical* to the chemical composition of the Earth. Biogeochemical cycles are driven by energy, directly or indirectly from the sun.

Figure 1.4 depicts an ecosystem where biotic and abiotic materials are constantly exchanged. Producers construct organic substances through photosynthesis and chemosynthesis. Consumers and decomposers use organic matter as their food and convert it into abiotic components; that is, they dissipate energy fixed by producers through food chains. The abiotic part of the pond in Figure 1.4 is formed of inorganic and organic compounds dissolved and in sediments such as carbon, oxygen, nitrogen, sulfur, calcium, hydrogen, and humic acids. Producers

such as rooted plants and phytoplanktons represent the biotic part. Fish, crustaceans, and insect larvae make up the consumers. Mayfly nymphs represent detritivores, which feed on organic detritus. Decomposers make up the final biotic part. They include aquatic bacteria and fungi, which are distributed throughout the pond.

Note: As stated earlier, an ecosystem is a cyclic mechanism. From a functional viewpoint, an ecosystem can be analyzed in terms of several factors. The factors important in this study include the biogeochemical cycles and energy and food chains.

1.8 ENERGY FLOW IN THE ECOSYSTEM

Simply defined, energy is the ability or capacity to do work. For an ecosystem to exist, it must have energy. All activities of living organisms involve work, which is the expenditure of energy. This means the degradation of a higher state of energy to a lower state. Two laws govern the flow of energy through an ecosystem: the *first* and *second laws of thermodynamics*. The first law, sometimes referred to as the *conservation law*, states that energy may not be created or destroyed. The second law states that no energy transformation is 100% efficient; that is, in every energy transformation, some energy is dissipated as heat. The term *entropy* is used as a measure of the nonavailability of energy to a system. Entropy increases with an increase in dissipation. Because of entropy, input of energy in any system is higher than the output or work done; thus, the resultant efficiency is less than 100%.

The interaction of energy and materials in the ecosystem is important. Energy drives the biogeochemical cycles. Note that energy does not cycle as nutrients do in biogeochemical cycles; for example, when food passes from one organism to another, energy contained in the food is reduced systematically until all of the energy in the system is dissipated as heat. Price (1984) referred to this process as “a unidirectional flow of energy through the system, with no possibility for recycling of energy.” When water or nutrients are recycled, energy is required. The energy expended in this recycling is not recyclable.

As mentioned, the principal source of energy for any ecosystem is sunlight. Green plants, through the process of photosynthesis, transform the energy of the sun into carbohydrates, which are consumed by animals. This transfer of energy, again, is unidirectional—from producers to consumers. Often, this transfer of energy to different organisms is referred to as a *food chain*. Figure 1.5 shows a simple aquatic food chain.

All organisms, alive or dead, are potential sources of food for other organisms. All organisms that share the same general type of food in a food chain are said to be at the same *trophic level* (nourishment or feeding



Figure 1.5 Aquatic food chain.

level). Because green plants use sunlight to produce food for animals, they are the *producers*, or the first trophic level. The herbivores, which eat plants directly, are the *primary consumers*, or the second trophic level. The carnivores are flesh-eating consumers; they include several trophic levels from the third on up. At each transfer, a large amount of energy (about 80 to 90%) is lost as heat and wastes. Thus, nature normally limits food chains to four or five links. In aquatic ecosystems, however, food chains are commonly longer than those on land. The aquatic food chain is longer because several predatory fish may be feeding on the plant consumers. Even so, the built-in inefficiency of the energy transfer process prevents development of extremely long food chains.

Only a few simple food chains are found in nature. Most simple food chains are interlocked. This interlocking of food chains forms a *food web*. Most ecosystems support a complex food web. A food web involves animals that do not feed on just one trophic level; for example, humans feed on both plants and animals. An organism in a food web may occupy one or more trophic levels. Trophic level is determined by an organism's role in its particular community, not by its species. Food chains and webs help to explain how energy moves through an ecosystem.

An important trophic level of the food web is comprised of the *decomposers*, which feed on dead plants or animals and play an important role in recycling nutrients in the ecosystem. Simply, there is no waste in ecosystems. All organisms, dead or alive, are potential sources of food for other organisms. An example of an aquatic food web is shown in Figure 1.6.

1.9 FOOD CHAIN EFFICIENCY

Earlier, we pointed out that energy from the sun is captured (via photosynthesis) by green plants and used to make food. Most of this energy is used to carry on the plant's life activities. The rest of the energy is passed on as food to the next level of the food chain. Nature limits the amount of energy that is accessible to organisms within each food chain. Not all food energy is transferred from one trophic level to the next. Only about 10% (the 10% rule) of the amount of energy is actually transferred through a food chain. If we apply the 10% rule to the

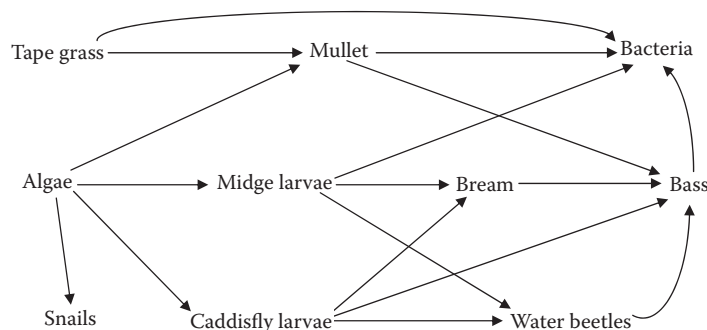

Figure 1.6 Aquatic food web.

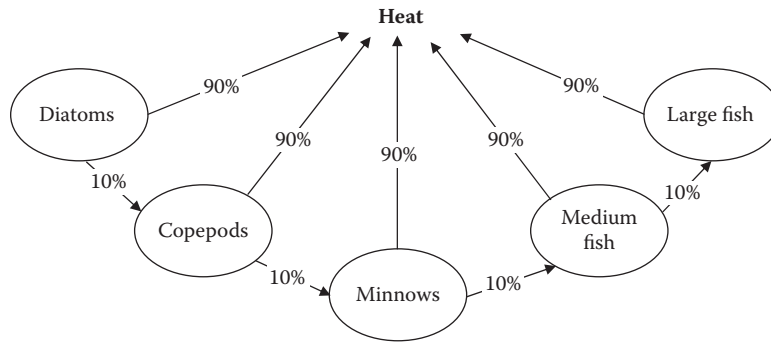

Figure 1.7 Simple food chain.

diatoms–copepods–minnows–medium fish–large fish food chain shown in Figure 1.7, we can predict that 1000 grams of diatoms produce 100 grams of copepods, which will produce 10 grams of minnows, which will produce 1 gram of medium fish, which, in turn, will produce 0.1 gram of large fish. Thus, only about 10% of the chemical energy available at each trophic level is transferred and stored in usable form at the next level. The other 90% is lost to the environment as low-quality heat in accordance with the second law of thermodynamics.

1.10 ECOLOGICAL PYRAMIDS

In a food chain, from the producer to the final consumer, it is clear that a particular community in nature often consists of several small organisms associated with a smaller and smaller number of larger organisms. A grassy field, for example, has a larger number of grasses and other small plants, a smaller number of herbivores such as rabbits, and an even smaller number of carnivores such as the fox. The practical significance of this is that we must have several more producers than consumers.

This pound-for-pound relationship, which requires more producers than consumers, can be demonstrated graphically by building an *ecological pyramid*. In an ecological pyramid, separate levels represent the number of organisms at various trophic levels in a food chain or bars placed one above the other with a base formed by producers and the apex formed by the final consumer. The pyramid shape is formed due to a great amount of energy loss at each trophic level. The same is true if the corresponding numbers are substituted by the corresponding biomass or energy. Ecologists generally use three types of ecological pyramids: *number*, *biomass*, and *energy*. Obviously, differences exist among them, but here are some generalizations:

1. Energy pyramids must always be larger at the base than at the top (because of the second law of thermodynamics and the dissipation of energy as it moves from one trophic level to another).
2. Likewise, biomass pyramids (in which biomass is used as an indicator of production) are usually pyramid shaped. This is particularly true of terrestrial systems and aquatic ones dominated by

large plants (marshes), in which consumption by heterotroph is low and organic matter accumulates with time. Biomass pyramids can sometimes be inverted. This is common in aquatic ecosystems where the primary producers are microscopic planktonic organisms that multiply very rapidly, have very short life spans, and are subject to heavy grazing by herbivores. At any single point in time, the amount of biomass in primary producers is less than that in larger, long-lived animals that consume primary producers.

3. Numbers pyramids can have various shapes (and not be pyramids at all), depending on the sizes of the organisms that make up the trophic levels. In forests, the primary producers are large trees, and the herbivore level usually consists of insects, so the base of the pyramid is smaller than the herbivore level above it. In grasslands, the number of primary producers (grasses) is much larger than that of the herbivores above (large grazing animals).

1.11 PRODUCTIVITY

As mentioned earlier, the flow of energy through an ecosystem starts with the fixation of sunlight by plants through photosynthesis. When evaluating an ecosystem, the measurement of photosynthesis is important. Ecosystems may be classified into highly productive or less productive; therefore, the study of ecosystems must involve some measure of the productivity of that ecosystem. Primary productivity is the rate at which the ecosystem's primary producers capture and store a given amount of energy, in a specified time interval. In simpler terms, primary productivity is a measure of the rate at which photosynthesis occurs. Four successive steps in the production process are:

1. *Gross primary productivity*—The total rate of photosynthesis in an ecosystem during a specified interval
2. *Net primary productivity*—The rate of energy storage in plant tissues in excess of the rate of aerobic respiration by primary producers
3. *Net community productivity*—The rate of storage of organic matter not used
4. *Secondary productivity*—The rate of energy storage at consumer levels

When attempting to comprehend the significance of the term *productivity* as it relates to ecosystems, it is wise to consider an example. Consider the productivity of an agricultural ecosystem such as a wheat field. Often its productivity is expressed as the number of bushels produced per acre. This is an example of the harvest method for measuring productivity. For a natural ecosystem, several 1-m² plots are marked off, and the harvest of the entire area is weighed to give an estimate of productivity as grams of biomass per square meter per given time interval. From this method, a measure of net primary production (net yield) can be measured.

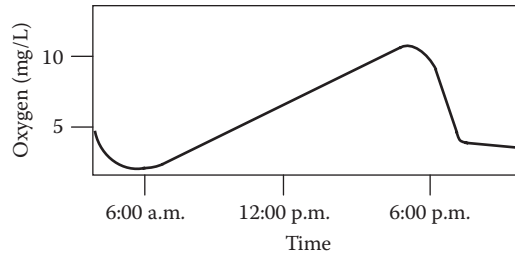

Figure 1.8 The diurnal oxygen curve for an aquatic ecosystem.

Productivity, in both natural and cultured ecosystems, may vary considerably, not only between types of ecosystems but also within the same ecosystem. Several factors influence year-to-year productivity within an ecosystem. Such factors as temperature, availability of nutrients, fire, animal grazing, and human cultivation activities are directly or indirectly related to the productivity of a particular ecosystem.

Productivity can be measured in several different ways in the aquatic ecosystem. For example, the production of oxygen may be used to determine productivity. Oxygen content may be measured in several ways. One way is to measure it in the water every few hours for a period of 24 hours. During daylight, when photosynthesis is occurring, the oxygen concentration should rise. At night, the oxygen level should drop. The oxygen level can be measured by using a simple x - y graph. The oxygen level can be plotted on the y -axis with time plotted on the x -axis, as shown in Figure 1.8.

Another method of measuring oxygen production in aquatic ecosystems is to use light and dark bottles. Biochemical oxygen demand (BOD) bottles (300 mL) are filled with water to a particular height. One of the bottles is tested for the initial dissolved oxygen (DO), and then the other two bottles (one clear, one dark) are suspended in the water at the depth from which they were taken. After a 12-hour period, the bottles are collected and the DO values for each bottle recorded. When the oxygen production is known, the productivity in terms of grams per meter per day can be calculated. In the aquatic ecosystem, pollution can have a profound impact upon the productivity of the system.

1.12 POPULATION ECOLOGY

Webster's Third New International Dictionary defines *population* as "the total number or amount of things especially within a given area; the organisms inhabiting a particular area or biotype; and a group of interbreeding biotypes that represents the level of organization at which speciation begins." The concept of population is interpreted differently in various sciences. In *human demography*, a population is a set of humans in a given area. In *genetics*, a population is a group of interbreeding individuals of the same species, which is isolated from other groups. In *population ecology*, a population is a group of individuals of the same species inhabiting the same area.

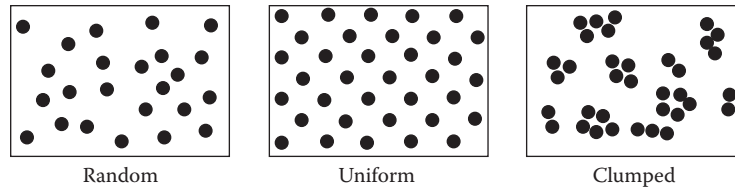

Figure 1.9 Basic patterns of distribution. (Adapted from Odum, E.P., *Fundamental of Ecology*, Saunders, Philadelphia, PA, 1971, p. 205.)

If we want to study the organisms in a slow-moving stream or stream pond, we would have two options. We can study each fish, aquatic plant, crustacean, and insect one by one, in which case we would be studying individuals. It would be relatively simple to do this if the subject were trout, but it would be difficult to separate and study each aquatic plant. The second option would be to study all of the trout, all of the insects of each specific kind, all of a certain aquatic plant type in the stream or pond at the time of the study. When ecologists study a group of the same kind of individuals in a given location at a given time, they are investigating a *population*. When attempting to determine the population of a particular species, it is important to remember that time is a factor. Time is important because populations change, whether it be at various times of the day, in different seasons of the year, or from year to year.

Population density may change dramatically. As an example, a dam closing off a river midway through spawning season, with no provision for allowing fish movement upstream (a fish ladder), would drastically decrease the density of spawning salmon upstream. Along with the swift and sometimes unpredictable consequences of change, it can be difficult to draw exact boundaries between various populations. The population density or level of a species depends on natality, mortality, immigration, and emigration. Changes in population density are the result of both births and deaths. The birth rate of a population is *natality* and the death rate *mortality*. In aquatic populations, two factors besides natality and mortality can affect density. In a run of returning salmon to their spawning grounds, for example, the density could vary as more salmon migrated in or as others left the run for their own spawning grounds. The arrival of new salmon to a population from other places is *immigration* (ingress); the departure of salmon from a population is *emigration* (egress). Thus, natality and immigration increase population density, whereas mortality and emigration decrease it. The net change in population is the difference between these two sets of factors.

Each organism occupies only those areas that can provide for its requirements, resulting in an irregular distribution. How a particular population is distributed within a given area has considerable influence on density. As shown in Figure 1.9, organisms in nature may be distributed in three ways. In a *random distribution*, there is an equal probability of an organism occupying any point in space, and each individual is independent of the others. In a *regular* or *uniform distribution*, in turn, organisms are spaced more evenly; they are not distributed by chance. Animals compete with each other and effectively defend a

specific territory, excluding other individuals of the same species. In regular or uniform distribution, the competition between individuals can be quite severe and antagonistic to the point where the spacing generated is quite even. The most common distribution is the *contiguous* or *clumped distribution*, where organisms are found in groups; this may reflect the heterogeneity of the habitat. Organisms that exhibit a contiguous or clumped distribution may develop social hierarchies to live together more effectively. Animals within the same species have evolved many symbolic aggressive displays that carry meanings that not only are mutually understood but also prevent injury or death within the same species.

The size of animal populations is constantly changing due to natality, mortality, emigration, and immigration. The population size will increase if the natality and immigration rates are high, and it will decrease if the mortality and emigration rates are high. Each population has an upper limit on size, often referred to as the *carrying capacity*. Carrying capacity is the optimum number of individuals of a species that can survive in a specific area over time. Stated differently, the carrying capacity is the maximum number of species that can be supported in a bioregion. A pond may be able to support only a dozen frogs depending on the food resources for the frogs in the pond. If there were 30 frogs in the same pond, at least half of them would probably die because the pond environment would not have enough food for them to live. Carrying capacity is based on the quantity of food supplies, the physical space available, the degree of predation, and several other environmental factors.

The carrying capacity can be of two types: ultimate and environmental. The *ultimate carrying capacity* is the theoretical maximum density; that is, it is the maximum number of individuals of a species in a place that can support itself without rendering the place uninhabitable. The *environmental carrying capacity* is the actual maximum population density that a species maintains in an area. Ultimate carrying capacity is always higher than environmental. Ecologists have concluded that a major factor that affects population stability or persistence is *species diversity*. Species diversity is a measure of the number of species and their relative abundance.

If the stress on an ecosystem is small, the ecosystem can usually adapt quite easily. Moreover, even when severe stress occurs, ecosystems have a way of adapting. Severe environmental change to an ecosystem can result from such natural occurrences as fires, earthquakes, and floods and from people-induced changes such as land clearing, surface mining, and pollution. One of the most important applications of species diversity is in the evaluation of pollution. Stress of any kind will reduce the species diversity of an ecosystem to a significant degree. In the case of domestic sewage pollution, for example, the stress is caused by a lack of dissolved oxygen (DO) for aquatic organisms.

Ecosystems can and do change; for example, if a fire devastates a forest, it will grow back eventually because of *ecological succession*. Ecological succession is the observed process of change (a normal

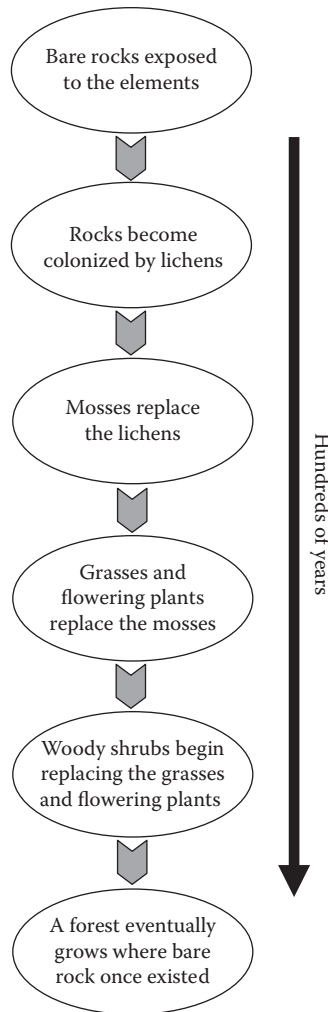

Figure 1.10 Bare-rock succession. (Adapted from Tomera, A.N., *Understanding Basic Ecological Concepts*, J. Weston Walch, Publisher, Portland, ME, 1989, p. 67.)

occurrence in nature) in the species structure of an ecological community over time. Succession usually occurs in an orderly, predictable manner. It involves the entire system. The science of ecology has developed to such a point that ecologists are now able to predict several years in advance what will occur in a given ecosystem. Scientists know, for example, that if a burned-out forest region receives light, water, nutrients, and an influx or immigration of animals and seeds, it will eventually develop into another forest through a sequence of steps or stages. Ecologists recognize two types of ecological succession: primary and secondary. The particular type that takes place depends on the condition at a particular site at the beginning of the process.

Primary succession, sometimes referred to as *bare-rock succession*, occurs on surfaces such as hardened volcanic lava, bare rock, and sand dunes, where no soil exists, and where nothing has ever grown before (See Figure 1.10). Obviously, to grow, plants require soil; thus,

soil must form on the bare rock before succession can begin. Usually this soil formation process results from weathering. Atmospheric exposure—weathering, wind, rain, and frost—produces tiny cracks and holes in rock surfaces. Water collects in the rock fissures and slowly dissolves the minerals out of the surface of the rock. A pioneer soil layer is formed from the dissolved minerals and supports such plants as lichens. Lichens gradually cover the rock surface and secrete carbonic acid, which dissolves additional minerals from the rock. Eventually, mosses replace the lichens. Organisms known as *decomposers* move in and feed on dead lichen and moss. A few small animals such as mites and spiders arrive next. The result is a *pioneer community*, which is defined as the first successful integration of plants, animals, and decomposers into a bare-rock community.

After several years, the pioneer community builds up enough organic matter in its soil to be able to support rooted plants such as herbs and shrubs. Eventually, the pioneer community is crowded out and is replaced by a different environment. This, in turn, works to thicken the upper soil layers. The progression continues through several other stages until a mature or climax ecosystem is developed, several decades later. In bare-rock succession, each stage in the complex succession pattern dooms the stage that existed before it. *Secondary succession* is the most common type of succession. Secondary succession occurs in an area where the natural vegetation has been removed or destroyed but the soil is not destroyed; for example, succession that occurs in abandoned farm fields, known as *old-field succession*, illustrates secondary succession. An example of secondary succession can be seen in the Piedmont region of North Carolina. Early settlers of the area cleared away the native oak–hickory forests and cultivated the land. In the ensuing years, the soil became depleted of nutrients, reducing the fertility of the soil. As a result, farming ceased in the region a few generations later, and the fields were abandoned. Some 150 to 200 years after abandonment, the climax oak–hickory forest was restored.

In an aquatic ecosystem, growth is enhanced by biotic and abiotic factors, including:

- Ability to produce offspring
- Ability to adapt to new environments
- Ability to migrate to new territories
- Ability to compete with species for food and space to live
- Ability to blend into the environment so as not to be eaten
- Ability to find food
- Ability to defend against enemies
- Favorable light
- Favorable temperature
- Favorable dissolved oxygen (DO) content
- Sufficient water level

The biotic and abiotic factors in an aquatic ecosystem that reduce growth include:

- Predators
- Disease
- Parasites
- Pollution
- Competition for space and food
- Unfavorable stream conditions (e.g., low water levels)
- Lack of food

With regard to stability of a freshwater ecosystem, the higher the species diversity the greater the inertia and resilience of the ecosystem is. When the species diversity is high within a stream ecosystem, a population within the stream can be out of control because of an imbalance between growth and reduction factors, but the ecosystem will remain stable at the same time. With regard to instability of a freshwater ecosystem, recall that imbalance occurs when growth and reduction factors are out of balance; for example, when sewage is accidentally dumped into a stream, the stream ecosystem, via the self-purification process, responds and returns to normal. This process can be described as follows:

1. Raw sewage is dumped into the stream.
2. Available oxygen decreases as the detritus food chain breaks down the sewage.
3. Some fish die at the pollution site and downstream.
4. Sewage is broken down, washes out to sea, and is finally broken down in the ocean.
5. Oxygen levels return to normal.
6. Fish populations that were depleted are restored as fish about the spill reproduce and the young occupy the real estate formerly occupied by the dead fish.
7. Populations all return to “normal.”

A shift in the balance of the ecosystem of a stream (or in any ecosystem) similar to the one just described is a common occurrence. In this particular case, the stream responded (on its own) to the imbalance the sewage caused, and through the self-purification process it returned to normal. Recall that succession is the method by which an ecosystem either forms itself or heals itself; thus, we can say that a type of succession occurred in our polluted stream example, because, in the end, it healed itself. More importantly, this healing process is a good thing; otherwise, long ago there would have been few streams on Earth suitable for much more than the dumping of garbage.

In summary, through research and observation, ecologists have found that the succession patterns in different ecosystems usually display common characteristics. First, succession brings about changes in the plant and animal members present. Second, organic matter increases from stage to stage. Finally, as each stage progresses, there is a tendency toward greater stability or persistence. Remember, succession is usually predictable. This is the case unless humans interfere.

1.13 STREAM GENESIS AND STRUCTURE

Consider the following: Early in the spring, on a snow- and ice-covered high alpine meadow, the water cycle continues. The main component of the cycle—water—has been held in reserve, literally frozen over the long, dark winter months. Now, though, because of the longer, warmer spring days, the sun is higher, more direct, and of longer duration, and the frozen masses of water respond to the increased warmth. The melt begins with a single drop, then two, then more. As the snow and ice melt, the drops of water join a chorus that continues apparently unending; they fall from ice-bound lips to the bare rock and soil terrain below.

The terrain on which the snowmelt falls is not like glacial till, which is an unconsolidated, heterogeneous mixture of clay, sand, gravel, and boulders dug out, ground out, and exposed by the force of a huge, slow, inexorably moving glacier. Instead, this soil and rock ground is exposed to the falling drops of snowmelt because of a combination of wind and the tiny, enduring force exerted by drops of water as season after season they collide with the thin soil cover, exposing the intimate bones of the Earth.

Gradually, the single drops increase to a small rush—they join to form a splashing, rebounding, helter-skelter cascade, many separate rivulets that trickle, then run their way down the face of the granite mountain. At an indented ledge halfway down the mountain slope, a pool forms whose beauty, clarity, and sweet iciness provide the visitor with an incomprehensible, incomparable gift—a blessing from Earth.

The mountain pool fills slowly, tranquil under the blue sky, reflecting the pines, snow and sky around and above it, an open invitation to lie down and drink and to peer into the glass-clear, deep phantom blue-green eye, so clear that it seems possible to reach down over 50 feet and touch the very bowels of the mountain. The pool has no transition from shallow margin to depth; it is simply deep and pure. As the pool fills with more melt water, we wish to freeze time, to hold this place and this pool in its perfect state forever, it is such a rarity to us in our modern world. However, this cannot be, as Mother Nature calls, prodding, urging. For a brief instant, the water laps in the breeze against the outermost edge of the ridge, then a trickle flows over the rim. The giant hand of gravity reaches out and tips the overflowing melt onward and it continues the downward journey, following the path of least resistance to its next destination, several thousand feet below.

When the overflow, still high in altitude but with its rock-strewn bed bent downward toward the sea, meets the angled, broken rocks below, it bounces, bursts, and mists its way against steep, V-shaped walls that form a small valley, carved out over time by water and the forces of the Earth. Within the valley confines, the melt water has grown from drops to rivulets to a small mass of flowing water. It flows through what is at first a narrow opening, gaining strength, speed, and power as the V-shaped valley widens to form a U shape. The journey continues as the water mass picks up speed and tumbles over massive boulders, and then slows again.

At a larger but shallower pool, waters from higher elevations have joined the main body—from the hillsides, crevices, springs, rills, and mountain creeks. At the influent poolsides, all appears peaceful, quiet, and restful, but not far away, at the effluent end of the pool, gravity takes control again. The overflow is flung over the jagged lip, and cascades downward several hundred feet, where the waterfall again brings its load to a violent, mist-filled meeting. The water separates and joins repeatedly, forming a deep, furious, wild stream that calms gradually as it continues to flow over lands that are less steep. The waters widen into pools overhung by vegetation, surrounded by tall trees. The pure, crystalline waters have become progressively discolored on their downward journey, stained brown-black with humic acid and literally filled with suspended sediments; the once-pure stream is now muddy.

The mass divides and flows in different directions over different landscapes. Small streams divert and flow into open country. Different soils work to retain or speed the waters, and in some places the waters spread out into shallow swamps, bogs, marshes, fens, or mires. Other streams pause long enough to fill deep depressions in the land and form lakes. For a time, the water remains and pauses on its journey to the sea, but this is only a short-term pause, because lakes are only a short-term resting place in the water cycle. The water will eventually move on, by evaporation or seepage into groundwater. Other portions of the water mass stay with the main flow, and the speed of flow changes to form a river, which braids its way through the landscape, heading for the sea. As it changes speed and slows the river bottom changes from rock and stone to silt and clay. Plants begin to grow, stems thicken, and leaves broaden. The river is now full of life and the nutrients necessary to sustain life. As the river courses onward, though, it meets its destiny when the flowing rich mass slows at last and finally spills into the sea.

Freshwater systems are divided into two broad categories: running waters (*lotic systems*) and standing waters (*lentic systems*). We concentrate here on lotic systems, although many of the principles described herein apply to other freshwater surface bodies as well, which are known by common names. Some examples include seeps, springs, brooks, branches, creeks, streams, and rivers. Again, because it is the best term to use in freshwater ecology, it is the stream we are concerned with here. Although there is no standard scientific definition of a stream, it is usually distinguished subjectively as follows: A stream is of intermediate size that can be waded from one side to the other.

Physical processes involved in the formation of a stream are important to the ecology of the stream, because stream channel and flow characteristics directly influence the functioning of the ecosystem of the stream and the biota found therein. Thus, in this section, we discuss the pathways of water flow contributing to stream flow; namely, we discuss precipitation inputs as they contribute to flow. We also discuss stream flow discharge, transport of material, characteristics of stream channels, stream profile, sinuosity, the flood plain, pool-riffle sequences, and depositional features—all of which directly or indirectly impact the ecology of the stream.

1.13.1 Water Flow in a Stream

Most elementary students learn early in their education process that water on Earth flows downhill—from land to the sea; however, they may or may not be told that water flows downhill toward the sea by various routes. The route (or pathway) that we are primarily concerned with is the surface water route taken by surface water runoff. Surface runoff is dependent on various factors; for example, climate, vegetation, topography, geology, soil characteristics, and land use all determine how much surface runoff occurs compared with other pathways.

The primary source (input) of water to total surface runoff is, of course, precipitation. This is the case even though a substantial portion of all precipitation input returns directly to the atmosphere by *evapotranspiration*, which is a combination process, as the name suggests, whereby water in plant tissue and in the soil evaporates and transpires to water vapor in the atmosphere. A substantial portion of precipitation input returns directly to the atmosphere by evapotranspiration. It is important to point out that when precipitation occurs some rainwater is intercepted by vegetation, from which it evaporates, never reaching the ground or being absorbed by plants. A large portion of the rainwater that reaches the ground, lakes, and streams also evaporates directly back to the atmosphere.

Although plants display a special adaptation to minimize transpiration, plants still lose water to the atmosphere during the exchange of gases necessary for photosynthesis. Notwithstanding the large percentage of precipitation that evaporates, rain or melt water that reaches the ground surface follows several pathways to reach a stream channel or groundwater.

Soil can absorb rainfall to its *infiltration capacity* (i.e., to its maximum rate). During a rain event, this capacity decreases. Any rainfall in excess of infiltration capacity accumulates on the surface. When this surface water exceeds the depression storage capacity of the surface, it moves as an irregular sheet of overland flow. In arid areas, overland flow is likely because of the low permeability of the soil. Overland flow is also likely when the surface is frozen or when human activities have rendered the land surface less permeable. In humid areas, where infiltration capacities are high, overland flow is rare.

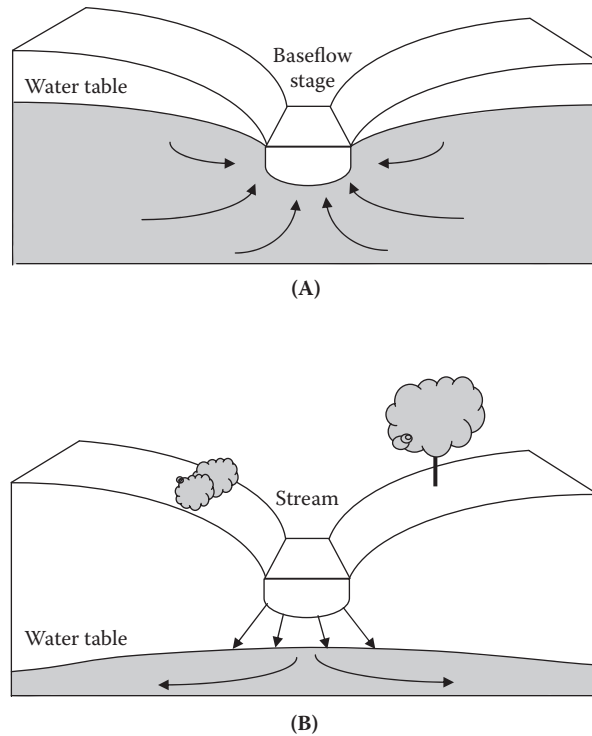

Figure 1.11 (A) Cross-section of a gaining stream; (B) cross-section of a losing stream.

In rain events, where the infiltration capacity of the soil is not exceeded, rain penetrates the soil and eventually reaches the groundwater—from which it discharges to the stream slowly and over a long period. This phenomenon helps to explain why stream flow through a dry-weather region remains constant; the flow is continuously augmented by groundwater. This type of stream is known as a *perennial stream*, as opposed to an *intermittent* one, because the flow continues during periods of no rainfall.

When a stream courses through a humid region, it is fed water via the water table, which slopes toward the stream channel. Discharge from the water table into the stream accounts for flow during periods without precipitation and explains why this flow increases, even without tributary input, as one proceeds downstream. Such streams are called *gaining* or *effluent*, as opposed to *losing* or *influent streams*, which lose water into the ground (see Figure 1.11). The same stream can shift between gaining and losing conditions along its course because of changes in underlying strata and local climate.

1.13.2 Stream Water Discharge

The current velocity (speed) of water (driven by gravitational energy) in a channel varies considerably within the cross-section of a stream due to friction with the bottom and sides, with sediment, and with the

atmosphere, as well as to sinuosity (bending or curving) and obstructions. Highest velocities, obviously, are found where friction is least, generally at or near the surface and near the center of the channel. In deeper streams, current velocity is greatest just below the surface due to the friction with the atmosphere; in shallower streams, current velocity is greatest at the surface due to friction with the bed. Velocity decreases as a function of depth, approaching zero at the substrate surface.

1.13.3 Transport of Material

Water flowing in a channel may exhibit *laminar flow* (parallel layers of water shear over one another vertically) or *turbulent flow* (complex mixing). In streams, laminar flow is uncommon, except at boundaries where flow is very low and in groundwater. The flow in streams is generally turbulent. Turbulence exerts a shearing force that causes particles to move along the streambed by pushing, rolling and skipping, referred to as the *bed load*. This same shear causes turbulent eddies that entrain particles in suspension, referred to as the *suspended load* (particle size under 0.06 mm).

Entrainment is the incorporation of particles when stream velocity exceeds the *entraining velocity* for a particular particle size. The entrained particles in suspension (suspended load) also include fine sediment, primarily clays, silts, and fine sands that require only low velocities and minor turbulence to remain in suspension. These are referred to as the *wash load* (particle size under 0.002 mm). Thus, the *suspended load* includes the wash load and coarser materials (at lower flows). Together, the suspended load and bed load constitute the *solid load*. It is important to note that in bedrock streams the bed load will be a lower fraction than in alluvial streams where channels are composed of easily transported material.

A substantial amount of material is also transported as the *dissolved load*. Solutes are generally derived from chemical weathering of bedrock and soils, and their contribution is greatest in subsurface flows and in regions of limestone geology. The relative amount of material transported as solute rather than solids load depends on basin characteristics, lithology (i.e., the physical character of rock), and the hydrologic pathways. In areas of very high runoff, the contribution of solutes approaches or exceeds sediment load, whereas in dry regions sediments make up as much as 90% of the total load.

Deposition occurs when *stream competence*—which refers to the largest particles that a stream can move, which in turn depends on the critical erosion competent of velocity—falls below a given velocity. Simply stated: The size of the particle that can be eroded and transported is a function of current velocity.

Sand particles are the most easily eroded. The greater the mass of larger particles (e.g., coarse gravel), the higher the initial current velocities must be for movement. Smaller particles (silts and clays), however, require even greater initial velocities because of their cohesiveness and

because they present smaller, streamlined surfaces to the flow. Once in transport, particles will continue in motion at somewhat slower velocities than initially required to initiate movement and will settle at still lower velocities.

Particle movement is determined by size, flow conditions, and mode of entrainment. Particles over 0.02 mm (medium–coarse sand size) tend to move by rolling or sliding along the channel bed as *traction load*. When sand particles fall out of the flow, they move by *saltation*, or repeated bouncing. Particles under 0.06 mm (silt) move as *suspended load*, and particles under 0.002 mm (clay) as *wash load*. Unless the supply of sediments becomes depleted, the concentration and amount of transported solids increase. Discharge is usually too low, throughout most of the year, to scrape or scour, shape channels, or move significant quantities of sediment in all but sand-bed streams, which can experience change more rapidly. During extreme events, the greatest scour occurs and the amount of material removed increases dramatically.

Sediment inflow into streams can be both increased and decreased because of human activities. For example, poor agricultural practices and deforestation greatly increase erosion. Fabricated structures such as dams and channel diversions, on the other hand, can greatly reduce sediment inflow.

1.13.4 Characteristics of Stream Channels

Flowing waters (rivers and streams) determine their own channels, and these channels exhibit relationships attesting to the operation of physical laws—laws that are not, as of yet, fully understood. The development of stream channels and entire drainage networks and the existence of various regular patterns in the shape of channels indicate that streams are in a state of dynamic equilibrium between erosion (sediment loading) and deposition (sediment deposit) and are governed by common hydraulic processes. Because channel geometry is four dimensional, with a long cross-section, depth, and slope profile, and because these mutually adjust over a time scale as short as years and as long as centuries or more, cause-and-effect relationships are difficult to establish. Other variables that are presumed to interact as the stream achieves its graded state include width and depth, velocity, size of sediment load, bed roughness, and the degree of braiding (sinuosity).

1.13.5 Stream Profiles

Mainly because of gravity, most streams exhibit a downstream decrease in gradient along their length. Beginning at the headwaters, the steep gradient becomes less so as one proceeds downstream, resulting in a concave longitudinal profile. Although diverse geography provides for almost unlimited variation, a lengthy stream that originates in a mountainous area typically comes into existence as a series of springs and rivulets; these coalesce into a fast-flowing, turbulent mountain stream, and the addition of tributaries results in a large and smoothly flowing river that winds through the lowlands to the sea.

When studying a stream system of any length, it becomes readily apparent (almost from the start) that what we are studying is a body of flowing water that varies considerably from place to place along its length. As an example, increases in discharge cause corresponding changes in the width, depth, and velocity of the stream. In addition to physical changes that occur from location to location along the course of a stream, a legion of biological variables correlate with stream size and distance downstream. The most apparent and striking changes are in steepness of slope and in the transition from a shallow stream with large boulders and a stony substrate to a deep stream with a sandy substrate. The particle size of bed material is also variable along the course of a stream. The particle size usually shifts from an abundance of coarser material upstream to mainly finer material in downstream areas.

1.13.6 Sinuosity

Unless forced by humans in the form of heavily regulated and channelized streams, straight channels are uncommon. Stream flow creates distinctive landforms composed of straight (usually in appearance only), meandering, and braided channels, channel networks, and flood plains. Simply put, flowing water will follow a sinuous course. The most commonly used measure is the *sinuosity index* (SI). Sinuosity equals 1 in straight channels and more than 1 in sinuous channels. *Meandering* is the natural tendency for alluvial channels and is usually defined as an arbitrarily extreme level of sinuosity, typically a SI greater than 1.5. Many variables affect the degree of sinuosity.

Even in many natural channel sections of a stream course that appear straight, meandering occurs in the line of maximum water or channel depth (known as the *thalweg*). Keep in mind that streams have to meander; that is how they renew themselves. By meandering, they wash plants and soil from the land into their waters, and these serve as nutrients for the plants in the rivers. If rivers are not allowed to meander, if they are *channelized*, the amount of life they can support will gradually decrease. That means fewer fish, as well as fewer bald eagles, herons, and other fishing birds (Spellman, 1996). Meander flow follows predictable pattern and causes regular regions of erosion and deposition (Figure 1.12). The streamlines of maximum velocity and the deepest part of the channel lie close to the outer side of each bend and cross over near the point of inflection between the banks. A huge elevation of water at the outside of a bend causes a helical flow of water toward the opposite bank. In addition, a separation of surface flow causes a back eddy. The result is zones of erosion and deposition and explains why point bars develop in a downstream direction in depositional zones.

1.13.7 Bars, Riffles, and Pools

Implicit in the morphology and formation of meanders are *bars*, *riffles*, and *pools*. Bars develop by deposition in slower, less competent flow on either side of the sinuous mainstream. Onward moving water, depleted of bed load, regains competence and shears a pool in

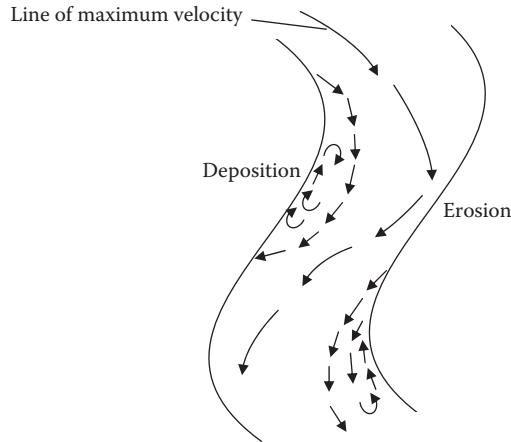

Figure 1.12 A meandering reach.

the meander, reloading the stream for the next bar. Alternating bars migrate to form riffles (see Figure 1.13). As stream flow continues along its course, a pool-riffle sequence is formed. The riffle is a mound or hill-ock and the pool is a depression.

1.13.8 The Flood Plain

A stream channel influences the shape of the valley floor through which it courses. The self-formed, self-adjusted flat area near the stream is the *flood plain*, which loosely describes the valley floor prone to periodic inundation during overbank discharges. What is not commonly known is that valley flooding is a regular and natural behavior of the stream. The aquatic community of a stream has several unique characteristics. Such a community operates under the same ecologic principles as terrestrial ecosystems, but the physical structure of the community is more isolated and exhibits limiting factors that are very different from the limiting factors of a terrestrial ecosystem.

Certain materials and conditions are necessary for the growth and reproduction of organisms. If, for example, a farmer plants wheat in a field containing too little nitrogen, the wheat will stop growing when it has used up the available nitrogen, even if the requirements of wheat for oxygen, water, potassium, and other nutrients are met. In this particular case, nitrogen is said to be the *limiting factor*. A limiting factor is a condition or a substance (the resource in shortest supply) that limits the presence and success of an organism or a group of organisms in an area.

Even the smallest mountain stream provides an astonishing number of different places for aquatic organisms to live, or *habitats*. If it is a rocky stream, every rock of the substrate provides several different habitats. On the side facing upriver, organisms with special adaptations, such as being able to cling to rock, do well. On the side that faces downriver, a certain degree of shelter is provided from the current, but

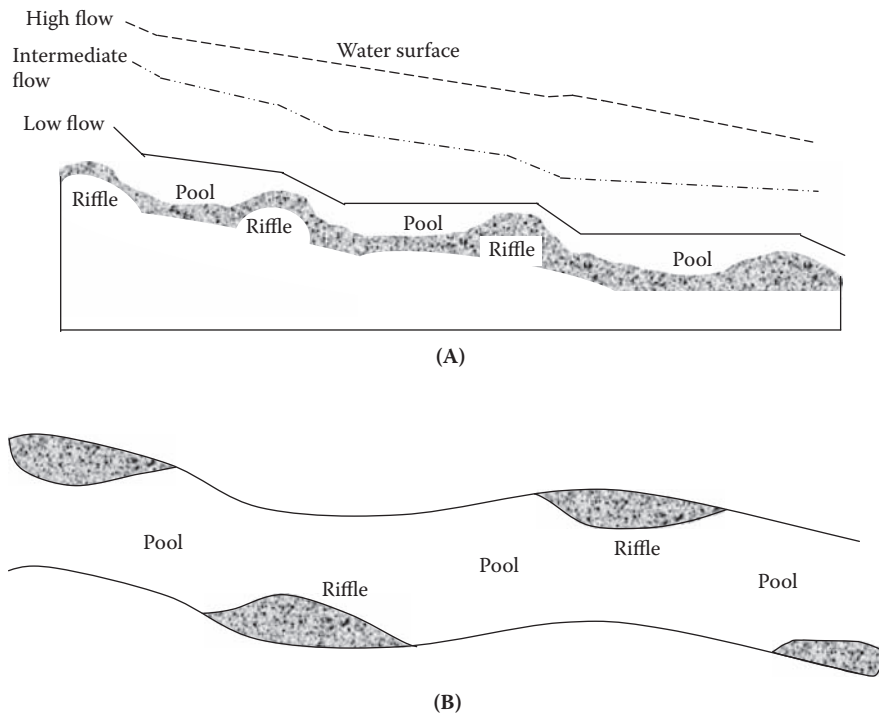

Figure 1.13 (A) Longitudinal profile of a riffle-pool sequence; (B) plain view of riffle-pool sequence.

organisms can still hunt for food. The top of a rock, if it contacts air, provides a good perch for organisms that cannot breathe underwater and need to surface now and then. Underneath the rock is a popular place for organisms that hide to prevent predation. Normal stream life can be compared to that of a balanced aquarium (ASTM, 1969); that is, nature continuously strives to provide clean, healthy, normal streams. This is accomplished by maintaining the flora and fauna of the stream in a balanced state. Nature balances stream life by maintaining both the number and the type of species present in any one part of the stream. Such balance prevents an overabundance of one species compared to another. Nature structures the stream environment so plant and animal life is dependent on the existence of others within the stream.

As mentioned, lotic (washed) habitats are characterized by continuously running water or current flow. These running water bodies typically have three zones: riffle, run, and pool. The *riffle zone* contains faster flowing, well-oxygenated water, with coarse sediments. In the riffle zone, the velocity of current is great enough to keep the bottom clear of silt and sludge, thus providing a firm bottom for organisms. This zone contains specialized organisms adapted to living in running water; for example, organisms adapted to living in fast streams or rapids (e.g., trout) have streamlined bodies that aid in their respiration and in obtaining food (Smith, 1996). Stream organisms that live under rocks to avoid the strong current have flat or streamlined bodies. Others have hooks or suckers to cling or attach to a firm substrate to avoid being washed away by the strong current. The *run zone* (or intermediate zone)

is the slow-moving, relatively shallow part of the stream with moderately low velocities and little or no surface turbulence. The *pool zone* of the stream is usually a deeper water region where the velocity of the water is reduced, and silt and other settling solids provide a soft bottom (more homogeneous sediments), which is unfavorable for sensitive bottom dwellers. Decomposition of some of these solids leads to a reduced amount of dissolved oxygen (DO). Some stream organisms spend part of their time in the rapids area of the stream, and at other times they can be found in the pool zone. Trout, for example, typically spend about the same amount of time in the rapid zone pursuing food as they do in the pool zone pursuing shelter.

Organisms are sometimes classified based on their mode of life:

- *Benthos* (mud dwellers)—The term originates from the Greek word for “bottom” and broadly includes aquatic organisms living on the bottom or on submerged vegetation. They live under and on rocks and in the sediments. A shallow sandy bottom has sponges, snails, earthworms, and some insects. A deep, muddy bottom will support clams, crayfish, and nymphs of damselflies, dragonflies, and mayflies. A firm, shallow, rocky bottom plays host to nymphs of mayflies and stoneflies and larvae of water beetles.
- *Periphytons* or *aufwuchs*—The first term usually refers to microfloral growth on substrata (e.g., benthic-attached algae). The second term, *aufwuchs* (pronounced OWF-vooks; German for “growth upon”) refers to the fuzzy, sort of furry-looking, slimy green coating that attaches or clings to stems and leaves of rooted plants or other objects projecting above the bottom without penetrating the surface. It consists not only of algae such as Chlorophyta but also diatoms, protozoans, bacteria, and fungi.
- *Planktons (drifters)*—These are small, mostly microscopic plants and animals that are suspended in the water column; movement depends on water currents. They usually float in the direction of the current. There are two types of planktons: (1) *Phytoplanktons* are assemblages of small plants (algae) that have limited locomotion abilities; they are subject to movement and distribution by water movements. (2) *Zooplanktons* are animals suspended in water and have limited means of locomotion. Examples of zooplanktons include crustaceans, protozoans, and rotifers.
- *Nektons* or *pelagic organisms* (capable of living in open waters)—Nektons are distinct from other planktons in that they are capable of swimming independently of turbulence; they are swimmers that can navigate against the current. Examples of nektons include fish, snakes, diving beetles, newts, turtles, birds, and large crayfish.
- *Neustons*—These organisms float or rest on the surface of the water (never break water tension). Some varieties are able to spread out their legs so the surface tension of the water is not broken (e.g., water striders) (see Figure 1.14).
- *Madricoles*—Organisms that live on rock faces in waterfalls or seepages.

In a stream, the rocky substrate is the home for many organisms; thus, we need to know something about the particles that make up the substrate. Namely, we need to know how to measure the particles so we can classify them by size. Substrate particles are measured with a metric ruler in centimeters (cm). Because rocks can be long and narrow, we measure them twice: first the width, then the length. By adding the width to the length and dividing by two, we obtain the average size of the rock.

It is important to randomly select the rocks we wish to measure; otherwise, we would tend to select larger rocks, more colorful rocks, or those with unusual shapes. Instead, we should just reach down and collect those rocks in front of us and within easy reach. We then measure each rock. Upon completion of measurement, each rock should be classified. Ecologists have developed a standard scale (Wentworth scale) for size categories of substrate rock and other mineral materials:

Boulder	>256 mm
Cobble	64–256 mm
Pebble	16–64 mm
Gravel	2–16 mm
Sand	0.0625–2 mm
Silt	0.0039–0.0625 mm
Clay	<0.0039 mm

Organisms that live in, on, or under rocks or in small spaces occupy what is known as a *microhabitat*. Some organisms make their own microhabitats; many caddisflies build cases about themselves to use as shelter.

Rocks are not the only physical features of streams where aquatic organisms can be found; for example, fallen logs and branches (commonly referred to as *large woody debris*, or LWD) provide an excellent place for some aquatic organisms to burrow into and for others to attach themselves, as they might to a rock. They also create areas where small detritus such as leaf litter can pile up underwater. These piles of leaf litter are excellent shelters for many organisms, including large, fiercely predaceous larvae of dobsonflies.

Another important aquatic organism habitat is found in the matter, or *drift*, that floats along downstream. Drift is important because it is the main source of food for many fish. It may include insects such as

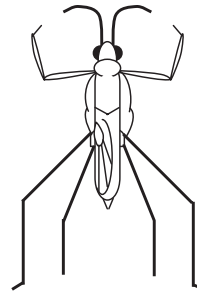

Figure 1.14 Waterstrider. (Adapted from APHA, *Standard Methods for the Examination of Water and Wastewater*, 15th ed. Copyright © 1981 by the American Public Health Association, the American Water Works Association, and the Water Pollution Control Federation.)

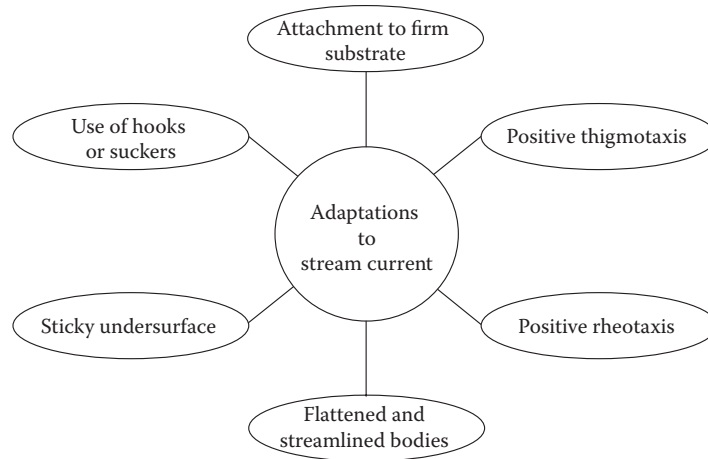

Figure 1.15 Adaptations to stream current.

mayflies (Ephemeroptera), some true flies (Diptera), and some stoneflies (Plecoptera) and caddisflies (Trichoptera). In addition, dead or dying insects and other small organisms, terrestrial insects that fall from the trees, leaves, and other matter are common components of drift. Among the crustaceans, amphipods (small crustaceans) and isopods (small crustaceans including sow bugs and gribbles) also have been reported in the drift.

1.13.9 Adaptations to Stream Current

The current is the outstanding feature of streams and the major factor limiting the distribution of organisms. The current is determined by the steepness of the bottom gradient, the roughness of the streambed, and the depth and width of the streambed. The current in streams has promoted many special adaptations by stream organisms. Odum (1971) listed these adaptations as follows (Figure 1.15):

- *Attachment to a firm substrate*—Attachment is to stones, logs, leaves, and other underwater objects such as discarded tires, bottles, pipes, etc. Organisms in this group are primarily composed of the primary producer plants and animals, such as green algae, diatoms, aquatic mosses, caddisfly larvae, and freshwater sponges.
- *The use of hooks and suckers*—These organisms have the unusual ability to remain attached and withstand even the strongest rapids. Two Diptera larvae, *Simulium* and *Blepharocera*, are examples.
- *A sticky undersurface*—Snails and flatworms are examples of organisms that are able to use their sticky undersurfaces to adhere to underwater surfaces.
- *Flattened and streamlined bodies*—All macroconsumers have streamlined bodies; that is, the body is broad in front and tapers posteriorly to offer minimum resistance to the current. All nektons such as fish, amphibians, and insect larvae exhibit this adaptation.

Some organisms have flattened bodies, which enable them to stay under rocks and in narrow places. Examples are water penny, beetle larva, mayfly, and stonefly nymphs.

- *Positive rheotaxis* (*rheo*, current; *taxis*, arrangement)—An inherent behavioral trait of stream animals (especially those capable of swimming) is to orient themselves upstream and swim against the current.
- *Positive thigmotaxis* (*thigmo*, touch or contact)—Another inherent behavior pattern for many stream animals is to cling close to a surface or keep the body in close contact with the surface. This is the reason why stonefly nymphs (when removed from one environment and placed into another) will attempt to cling to just about anything, including each other.

It would take an entire text to describe the great number of adaptations made by aquatic organisms to their surroundings in streams. For our purposes, instead, we cover those special adaptations that are germane to this discussion. The important thing to remember is that an aquatic organism can adapt to its environment in several basic ways.

1.13.9.1 Types of Adaptive Changes

Adaptive changes are classed as genotypic, phenotypic, behavioral, or ontogenic:

- *Genotypic changes* tend to be great enough to separate closely related animals into species, such as mutations or recombination of genes. A salmonid is an example that has evolved a subterminal mouth (i.e., below the snout) to eat from the benthos.
- *Phenotypic changes* are the changes that an organism might make during its lifetime to better utilize its environment (e.g., a fish that changes sex from female to male because of an absence of males).
- *Behavioral changes* have little to do with body structure or type; for example, a fish might spend more time under an overhang to hide from predators.
- *Ontogenetic changes* take place as an organism grows and matures (e.g., Coho salmon, which inhabits streams when young and migrates to the sea when older, changing its body chemistry to allow it to tolerate saltwater).

1.13.9.2 Specific Adaptations

Specific adaptations observed in aquatic organisms include their mouth, shape, color, aestivation, and schooling:

- *Mouth*—The mouth shape (morphology) of aquatic organisms such as fish varies depending on the food the fish eats. The arrangement of the jawbones and even other head bones; the length and width of

gill rakers; the number, shape, and location of teeth; and the presence of barbels all change to allow fish to eat just about anything found in a stream.

- **Shape**—Changes in shape allow fish to do different things in the water. Some organisms have body shapes that push them down in the water, against the substrate, and allow them to hold their place against even strong current (e.g., chubs, catfish, dace, sculpins). Other organisms (e.g., bass, perch, pike, trout, and sunfish) have evolved an arrangement and shape of fins that allow them to lurk without moving so they can lunge suddenly to catch their prey.
- **Color**—Color may change within hours, to camouflage, or in a matter of days, or it may be genetically predetermined. Fish tend to turn dark in clear water and pale in muddy water.
- **Aestivation**—Aestivation, the ability of some fishes to burrow into the mud and wait out a dry period, helps the fish to survive in arid desert climates, where streams may dry up from time to time.
- **Schooling**—Schooling serves as protection for many fish, particularly those that are subject to predation.

1.14 BENTHIC LIFE

The benthic habitat is found in the streambed, or benthos. As mentioned, the streambed is comprised of various physical and organic materials, and erosion and deposition are continuous factors. Erosion and deposition may occur simultaneously and alternately at different locations in the same streambed. Where channels are exceptionally deep and taper slowly to meet the relatively flattened streambed, habitats may form on the slopes of the channel. These habitats are referred to as *littoral habitats*. Shallow channels may dry up periodically in accordance with weather changes. The streambed is then exposed to open air and may take on the characteristics of a wetland.

Silt and organic materials settle and accumulate in the streambed of slowly flowing streams. These materials decay and become the primary food resource for the invertebrates inhabiting the streambed. Productivity in this habitat depends on the breakdown of these organic materials by herbivores. Bottom-dwelling organisms do not use all of the organic materials; a substantial amount becomes part of the streambed in the form of peat.

In faster moving streams, organic materials do not accumulate so easily. Primary production occurs in a different type of habitat found in the riffle regions with shoals and rocky regions for organisms to adhere to. Plants that can root themselves into the streambed dominate these regions. By plants, we are referring mostly to forms of algae, often microscopic and filamentous, that can cover rocks and debris that have settled into the streambed during summer months.

Note: If you have ever stepped into a stream, the green, slippery slime on the rocks in the streambed is representative of this type of algae.

Although the filamentous algae seem well anchored, strong currents can easily lift the algae from the streambed and carry them downstream, where they become a food resource for low-level consumers. One factor that greatly influences the productivity of a stream is the width of the channel; a direct relationship exists between stream width and richness of bottom organisms. Bottom-dwelling organisms are very important to the ecosystem, as they provide food for other, larger benthic organisms by consuming detritus.

1.15 BENTHIC PLANTS AND ANIMALS

Vegetation is not common in the streambed of slow-moving streams; however, vegetation may anchor along the banks. Algae (mainly green and blue-green) as well as common types of water moss attach themselves to rocks in fast-moving streams. Mosses and liverworts often climb up the sides of the channel onto the banks, as well. Some plants similar to the reeds of wetlands with long stems and narrow leaves are able to maintain roots and withstand the current. Aquatic insects and invertebrates dominate slow-moving streams. Most aquatic insects are in their larval and nymph forms such as the blackfly, caddisfly, and stonefly. Adult water beetles and waterbugs are also abundant. Insect larvae and nymphs provide the primary food source for many fish species, including American eel and brown bullhead catfish. Representatives of crustaceans, rotifers, and nematodes (flat worms) are sometimes present. The abundance of leeches, worms, and mollusks (especially freshwater mussels) varies with stream conditions but generally favors low-phosphate conditions. Larger animals found in slow-moving streams and rivers include newts, tadpoles, and frogs. As mentioned, the important characteristic of all life in streams is adaptability to withstand currents.

1.16 BENTHIC MACROINVERTEBRATES

The emphasis of aquatic insect studies, which have expanded exponentially in the last several decades, has been largely ecological. Freshwater macroinvertebrates are ubiquitous; even polluted waters contain some representative of this diverse and ecologically important group of organisms. Benthic macroinvertebrates are aquatic organisms without backbones that spend at least a part of their life cycle on the stream bottom. Examples include aquatic insects, such as stoneflies, mayflies, caddisflies, midges, and beetles, as well as crayfish, worms, clams, and snails. Most hatch from eggs and mature from larvae to adults. The majority of the insects spend their larval phase on the river bottom and, after a few weeks to several years, emerge as winged adults. The aquatic beetles, true bugs, and other groups remain in the water as adults. Macroinvertebrates typically collected from the stream substrate are either aquatic larvae or adults.

In practice, stream ecologists observe indicator organisms and their responses to determine the quality of the stream environment. A number of methods can be used to determine water quality based on biologic characteristics. A wide variety of indicator organisms (biotic

groups) can be used for biomonitoring. Those used most often include algae, bacteria, fish, and macroinvertebrates. Notwithstanding their popularity, in this text we discuss benthic macroinvertebrates because they offer a number of advantages:

- They are ubiquitous, so they are affected by perturbations in many different habitats.
- They are species rich, so the large number of species produces a range of responses.
- They are sedentary, so they stay put, which allows determination of the spatial extent of a perturbation.
- They are long-lived, which allows us to follow temporal changes in abundance and age structure.
- They integrate conditions temporally, so, like any biotic group, they provide evidence of conditions over long periods.

In addition, benthic macroinvertebrates are preferred as bioindicators because they are easily collected and handled by samplers; they require no special culture protocols. They are visible to the naked eye, and samplers can easily distinguish their characteristics. They have a variety of fascinating adaptations to stream life. Certain benthic macroinvertebrates have very special tolerances and thus are excellent specific indicators of water quality. Useful benthic macroinvertebrate data are easy to collect without expensive equipment. The data obtained by macroinvertebrate sampling can serve to indicate the need for additional data collection, possibly including water analysis and fish sampling.

In short, we base the focus of this discussion on benthic macroinvertebrates (with regard to water quality in streams and lakes) simply because some cannot survive in polluted water while others can survive or even thrive in polluted water. In a healthy stream, the benthic community includes a variety of pollution-sensitive macroinvertebrates. In an unhealthy stream or lake, only a few types of nonsensitive macroinvertebrates may be present; thus, the presence or absence of certain benthic macroinvertebrates is an excellent indicator of water quality.

Moreover, it may be difficult to identify stream or lake pollution with water analysis, which can only provide information for the time of sampling (a snapshot of time). Even the presence of fish may not provide information about a polluted stream because fish can move away to avoid polluted water and then return when conditions improve. In contrast, most benthic macroinvertebrates cannot move to avoid pollution; thus, a macroinvertebrate sample may provide information about pollution that is not present at the time of sample collection.

Obviously, before we can use benthic macroinvertebrates to gauge water quality in a stream (or for any other reason), we must be familiar with the macroinvertebrates that are commonly used as bioindicators. Samplers must be aware of basic insect structures before they can classify the macroinvertebrates they collect. Structures that need to be stressed include head, eyes (compound and simple), antennae, mouth

(no emphasis on parts), segments, thorax, legs and leg parts, gills, and abdomen. Samplers also should be familiar with insect metamorphosis—both complete and incomplete—as most of the macroinvertebrates collected are larval or nymph stages.

Note: Information on basic insect structures is beyond the scope of this text, so we highly recommend the standard guide to aquatic insects of North America, *An Introduction to the Aquatic Insects of North America*, 3rd ed., edited by R.W. Merritt and K.W. Cummins (Kendall/Hunt Publishing, 1996).

1.16.1 Identification of Benthic Macroinvertebrates

Before identifying and describing the key benthic macroinvertebrates significant to water/wastewater operators, it is important first to provide foundational information. We characterize benthic macroinvertebrates using two important descriptive classifications: *trophic groups* and *mode of existence*. In addition, we discuss their relationship in the food web—that is, what, or whom, they eat:

1. *Trophic groups*—Of the trophic groups (i.e., feeding groups) that Merritt and Cummins (1996) identified for aquatic insects, only five are likely to be found in a stream using typical collection and sorting methods:

- *Shredders* have strong, sharp mouthparts that allow them to shred and chew coarse organic material such as leaves, algae, and rooted aquatic plants. These organisms play an important role in breaking down leaves or larger pieces of organic material to a size that can be used by other macroinvertebrates. Shredders include certain stonefly and caddisfly larvae, sowbugs, scuds, and others.
- *Collectors* gather the very finest suspended matter in the water. To do this, they often sieve the water through rows of tiny hairs. These sieves of hairs may be displayed in fans on their heads (blackfly larvae) or on their forelegs (some mayflies). Some caddisflies and midges spin nets and catch their food in them as the water flows through.
- *Scrapers* scrape the algae and diatoms off surfaces of rocks and debris using their mouthparts. Many of these organisms are flattened to hold onto surfaces while feeding. Scrapers include water pennies, limpets and snails, netwinged midge larvae, and certain mayfly larvae, among others.
- *Piercers* are herbivores that pierce plant tissues or cells and suck the fluids out. Some caddisflies do this.
- *Predators* eat other living creatures. Some of these are *engulfers*; that is, they eat their prey completely or in parts. This is very common in stoneflies and dragonflies, as well as caddisflies. Others are *piercers*, which are similar to the herbivorous piercers except that they eat live animal tissues.

2. *Mode of existence* (habit, locomotion, attachment, concealment)—
Examples include the following:

- *Skaters* (e.g., water striders) are adapted for skating on the surface where they feed as scavengers on organisms trapped in the surface film.
- *Planktonic* types inhabit the open water limnetic zone of standing (lentic) waters (lakes, bogs, ponds). Representatives may float and swim about in the open water but usually exhibit a diurnal vertical migration pattern (e.g., phantom midges) or float at the surface to obtain oxygen and food, diving when alarmed (e.g., mosquitoes).
- *Divers* (e.g., water boatmen, predaceous diving beetles) are adapted for swimming by rowing with their hind legs in lentic habitats and lotic pools. They come to the surface to obtain oxygen but dive and swim when feeding or alarmed; they may cling to or crawl on submerged objects such as vascular plants.
- *Swimmers* (e.g., mayflies) are adapted for fishlike swimming in lotic or lentic habitats. Individuals usually cling to submerged objects, such as rocks (lotic riffles) or vascular plants (lentic), between short bursts of swimming.
- *Clingers* (e.g., mayflies and caddisflies) have behavioral adaptations (such as fixed retreat construction) and morphological adaptations (such as long, curved tarsal claws, dorsoventral flattening, ventral gills arranged as a sucker) for attachment to surfaces in stream riffles and wave-swept rocky littoral zones of lakes.
- *Sprawlers* (e.g., mayflies, dobsonflies, damselflies) inhabit the surface of floating leaves of vascular hydrophytes or fine sediments and usually have modifications for staying on top of the substrate and keeping the respiratory surfaces free of silt.
- *Climbers* (e.g., dragonflies and damselflies) are adapted for living on vascular hydrophytes or detrital debris (overhanging branches, roots, and vegetation along streams and submerged brush in lakes) with modifications for moving vertically on stem-type surfaces.
- *Burrowers* (e.g., mayflies and midges) inhabit the fine sediments of streams (pools) and lakes. Some construct discrete burrows, which may have sand grain tubes extending above the surface of the substrate or the individuals; they may ingest their way through the sediments.

1.16.2 Macroinvertebrates and the Food Web

In a stream or lake, the two possible sources of primary energy are (1) photosynthesis by algae, mosses, and higher aquatic plants, and (2) imported organic matter from streamside or lakeside vegetation (e.g., leaves and other parts of vegetation). Simply put, a significant portion of the food that is eaten grows right in the stream or lake—for example,

algae, diatoms, nymphs and larvae, and fish. A food that originates from within the stream is *autochthonous*. Most food in a stream, however, comes from outside the stream—especially in small, heavily wooded streams, which normally have insufficient light to support substantial instream photosynthesis so energy pathways are supported largely by imported energy. Leaves provide a large portion of this imported energy. Worms drown in floods and are washed in. Leafhoppers and caterpillars fall from trees. Adult mayflies and other insects mate above the stream, lay their eggs in it, and then die in it. All of this food from outside the stream is *allochthonous*.

1.16.3 Units of Organization

Macroinvertebrates, like all other organisms, are classified and named. Macroinvertebrates are classified and named using a *taxonomic hierarchy*. The taxonomic hierarchy for the caddisfly (a macroinvertebrate insect commonly found in streams) is shown below:

Kingdom—Animalia (animals)

Phylum—Arthropoda (“jointed legs”)

Class—Insecta (insect)

Order—Trichoptera (caddisfly)

Family—Hydropsychidae (net-spinning caddis)

Genus and species—*Hydropsyche morosa*

1.17 TYPICAL BENTHIC MACROINVERTEBRATES IN RUNNING WATERS

As mentioned, the macroinvertebrates are the best-studied and most diverse animals in streams. We therefore devote our discussion to the various macroinvertebrate groups. Although it is true that non-insect macroinvertebrates, such as Oligochaeta (worms), Hirudinea (leeches), and Acari (water mites), are frequently encountered groups in lotic environments, the insects are among the most conspicuous inhabitants of streams. In most cases, it is the larval stages of these insects that are aquatic, whereas the adults are terrestrial. Typically, the larval stage is much extended while the adult lifespan is short. Lotic insects are found among many different orders, and brief accounts of their biology are presented in the following sections.

1.17.1 Insect Macroinvertebrates

The most important insect groups in streams are Ephemeroptera (mayflies), Plecoptera (stoneflies), Trichoptera (caddisflies), Diptera (true flies), Coleoptera (beetles), Hemiptera (bugs), Megaloptera (alderflies and dobsonflies), and Odonata (dragonflies and damselflies). The identification of these different orders is usually easy, and many keys and

specialized references are available to help in the identification of species (e.g., Merritt and Cummins, 1996). In contrast, specialist taxonomists are often required to identify some genera and species, particularly the order Diptera. As mentioned, insect macroinvertebrates are ubiquitous in streams and are often represented by many species. The macroinvertebrates discussed below are aquatic species, and a majority of these species can be found in streams.

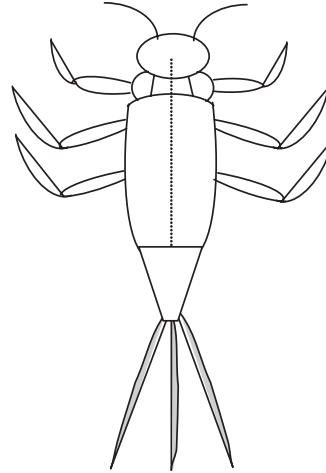

1.17.1.1 Mayflies (Order: Ephemeroptera)

Streams and rivers are generally inhabited by many species of mayflies, and, in fact, most species are restricted to streams. For the experienced freshwater ecologist who looks upon a mayfly nymph, recognition is obtained through trained observation: abdomen with leaf-like or feather-like gills, legs with a single tarsal claw, generally (but not always) with three cerci (“tails”—two cerci and between them usually a terminal filament) (see Figure 1.16). The experienced ecologist knows that mayflies are hemimetabolous insects (i.e., larvae or nymphs resemble wingless adults) that go through many postembryonic molts, often in a range of between 20 and 30. For some species, body length increases about 15% for each instar.

Figure 1.16 Mayfly (Order: Ephemeroptera).

Mayfly nymphs are mainly grazers or collector-gatherers feeding on algae and fine detritus, although a few genera are predatory. Some members filter particles from the water using hair-fringed legs or maxillary palps. Shredders are rare among mayflies. In general, mayfly nymphs tend to live primarily in unpolluted streams, where, with densities of up to 10,000 m², they contribute substantially to secondary producers.

Adult mayflies resemble nymphs but usually possess two pair of long, lacy wings folded upright; adults usually have only two cerci. The adult lifespan is short, ranging from a few hours to a few days, rarely up to two weeks, and the adults do not feed. Mayflies are unique among insects in having two winged stages, the subimago and the imago. The emergence of adults tends to be synchronous, thus ensuring the survival of enough adults to continue the species.

1.17.1.2 Stoneflies (Order: Plecoptera)

Although many freshwater ecologists would maintain that the stonefly is a well-studied group of insects, this is not exactly the case. Despite their importance, less than 5 to 10% of stonefly species are well known with respect to life history, trophic interactions, growth, development, spatial distribution, and nymphal behavior. Notwithstanding our lack of extensive knowledge with regard to stoneflies, enough is known to provide an accurate characterization of these aquatic insects. We

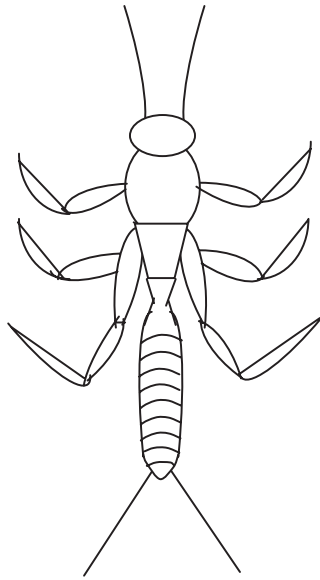

Figure 1.17 Stonefly (Order: Plecoptera).

know, for example, that stonefly larvae are characteristic inhabitants of cool, clean streams (most nymphs occur under stones in well-aerated streams). They are sensitive to organic pollution or, more precisely, to low oxygen concentrations accompanying organic breakdown processes, but stoneflies seem rather tolerant to acidic conditions. Lack of extensive gills at least partly explains their relative intolerance of low oxygen levels.

Stoneflies are drab-colored, small-to medium-sized (4 to 60 mm; 1/6 to 2-1/4 inches), rather flattened insects. Stoneflies have long, slender, many-segmented antennae and two long narrow antenna-like structures (cerci) on the tip of the abdomen (see Figure 1.17). The cerci may be long or short. At rest, the wings are held flat over the abdomen, giving a “square-shouldered” look compared

to the roof-like position of most caddisflies and vertical position of the mayflies. Stoneflies have two pair of wings. The hind wings are slightly shorter than the forewings and much wider, having a large anal lobe that is folded fanwise when the wings are at rest. This fanlike folding of the wings gives rise to the name of the order: *pleco* (“folded or plaited”) and *ptera* (“wings”). The aquatic nymphs are generally very similar to mayfly nymphs except that they have only two cerci at the tip of the abdomen. The stoneflies have chewing mouthparts. They may be found anywhere in a nonpolluted stream that food is available. Many adults, however, do not feed and have reduced or vestigial mouthparts.

Stoneflies have a specific niche in high-quality streams where they are very important as a fish food source at specific times of the year (winter to spring, especially) and of the day. They complement other important food sources, such as caddisflies, mayflies, and midges.

1.17.1.3 Caddisflies (Order: Trichoptera)

Trichoptera (*trichos*, “hair”; *ptera*, “wings”) represents one of the most diverse insect orders living in the stream environment, and caddisflies have nearly a worldwide distribution, with the exception of Antarctica. Caddisflies may be categorized broadly into free-living (roving and net spinning) and case-building species.

Caddisflies are described as medium-sized insects with bristle-like and often long antennae. They have membranous hairy wings (which explains the use of *trichos* in the name), which are held tent-like over the body when at rest; most are weak fliers. They have greatly reduced mouthparts and five tarsi. The larvae are mostly caterpillar like and have a strongly sclerotized (hardened) head with very short antennae

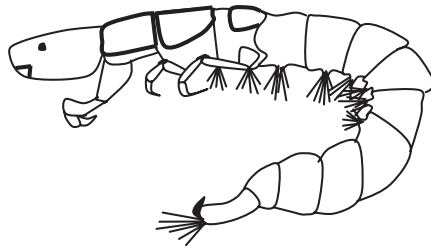

Figure 1.18 Caddis larvae, *Hydropsyche* spp.

and biting mouthparts. They have well-developed legs with a single tarsi. The abdomen usually has ten segments; in case-bearing species, the first segment bears three papillae, one dorsally and the other two laterally, which helps hold the insect centrally in its case and allows a good flow of water to pass the cuticle and gills. The last or anal segment bears a pair of grappling hooks.

In addition to being aquatic insects, caddisflies are superb architects. Most caddisfly larvae (see Figure 1.18) live in self-designed, self-built houses called *cases*. They spin out silk, and either live in silk nets or use the silk to stick together bits of whatever is lying on the stream bottom. These houses are so specialized, that we can usually identify the genus of a caddisfly larva if we can see its house (case). With nearly 1400 species of caddisfly species in North America (north of Mexico), this is a good thing!

Caddisflies are closely related to butterflies and moths (Order: Lepidoptera). They live in most stream habitats, and that is why they are so diverse. Each species has particular adaptations that allow it to survive in its environment. Mostly herbivorous, most caddisflies feed on decaying plant tissue and algae. Their favorite algae are diatoms, which they scrape off rocks. Some of them, though, are predacious.

Caddisfly larvae can take a year or two to change into adults. They change into *pupae* (the inactive stage in the metamorphosis of many insects, following the larval stage and preceding the adult form) while still inside the cases built for their metamorphosis. It is interesting to note that caddisflies, unlike stoneflies and mayflies, go through a complete metamorphosis. Caddisflies remain as pupae for 2 to 3 weeks, then emerge as adults. When they split open their cases and leave, they must swim to the surface of the water to escape it. The winged adults fly in the evening and at night, and some are known to feed on plant nectar. Most of them will live less than a month; like many other winged stream insects, their adult lives are brief compared to the time they spend in the water as larvae.

Caddisflies are sometimes grouped into five main groups according to the kinds of cases they build: (1) free-living forms that do not make cases, (2) saddle-case makers, (3) purse-case makers, (4) net-spinners and retreat makers, and (5) tube-case makers. Caddisflies demonstrate their architectural talents in the cases they design and build; for example, a caddisfly might build a perfect, four-sided box case of bits of

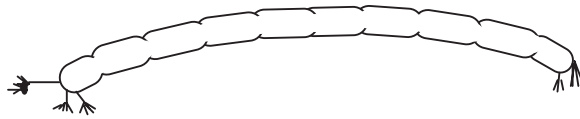

Figure 1.19 Midge larvae.

leaves and bark or tiny bits of twigs. It may make a clumsy dome of large pebbles. Another might construct rounded tubes out of twigs or very small pebbles. In our experience in gathering caddisflies, we have come to appreciate not only their architectural ability but also their flare in the selection of construction materials. We have found many caddisfly cases constructed of silk that was emitted through an opening at the tip of the labium and was combined with bits of ordinary rock mixed with sparkling quartz and red garnet, green peridot, and bright fool's gold.

In addition to the protection they provide, the cases offer another advantage in that they actually help caddisflies breathe. The caddisfly moves its body up and down, back and forth, inside its case, which produces a current that brings them fresh oxygen. The less oxygen there is in the water, the faster they have to move. It has been seen that caddisflies inside their cases get more oxygen than those that are outside of their cases—and this is why stream ecologists think that caddisflies can often be found even in still waters, where dissolved oxygen is low, in contrast to stoneflies and mayflies.

1.17.1.4 True Flies (Order: Diptera)

True or two- (*di-*) winged (*ptera*) flies include not only the flies that we are most familiar with, such as fruitflies and houseflies, but also midges (see Figure 1.19), mosquitoes, craneflies (see Figure 1.20), and others. Houseflies and fruitflies live only on land, and we do not concern ourselves with them. Some, however, spend nearly their entire lives in water; they contribute to the ecology of streams.

True flies are in the order Diptera, one of the most diverse orders of the class Insecta, with about 120,000 species worldwide. Dipteran larvae occur almost everywhere except Antarctica and deserts where there is no running water. They may live in a variety of places within a stream: buried in sediments, attached to rocks, beneath stones, in saturated wood or moss, or in silken tubes attached to the stream bottom. Some even live below the stream bottom. True fly larvae may eat almost anything, depending on their species. Those with brushes on their heads use them to strain food out of the water that passes through. Others may eat algae, detritus, plants, and even other fly larvae.

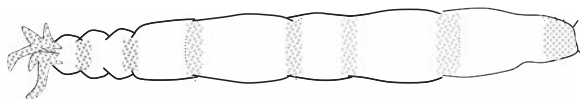

Figure 1.20 Cranefly larvae.

The longest part of the true fly's life cycle, like that of mayflies, stoneflies, and caddisflies, is the larval stage. It may remain an underwater larva anywhere from a few hours to 5 years. The colder the environment, the longer it takes to mature. It pupates and emerges and then becomes a winged adult. The adult may live 4 months—or it may live for only a few days. While reproducing, it will often eat plant nectar for the energy it needs to make its eggs. Mating sometimes takes place in aerial swarms. The eggs are deposited back in the stream; some females will crawl along the stream bottom, losing their wings in the process, to search for the perfect place to put their eggs. Once they lay them, they die.

Diptera serve an important role in cleaning water and breaking down decaying material, and they are a vital food source for many of the animals living in and around streams, as they play pivotal roles in the processing of food energy. The true flies most familiar to us, however, are the midges, mosquitoes, and the crane flies, because they are pests. Some midge flies and mosquitoes bite; the crane fly does not bite but looks like a giant mosquito.

Like mayflies, stoneflies, and caddisflies, true flies are mostly in larval form. Just as for caddisflies, we can find their pupae, because they are holometabolous insects; that is, they go through complete metamorphosis. Most of them are free living and travel around. Although none of the true fly larvae has the six jointed legs that we see on other insects in the stream, they sometimes have strange little almost-legs (prolegs) to move around with. Others may move somewhat like worms do, and some—the ones that live in waterfalls and rapids—have a row of six suction discs that they use to move much like a caterpillar does. Many use silk pads and hooks at the ends of their abdomens to hold them fast to smooth rock surfaces.

1.17.1.5 Beetles (Order: Coleoptera)

Of the more than 1 million described species of insect, at least one third are beetles, making Coleoptera not only the largest order of insects but also the most diverse order of living organisms. Even though this is the most speciose order of terrestrial insects, surprisingly their diversity is not so apparent in running waters. Coleoptera belongs to the infraclass Neoptera, division Endpterygota. Members of this order have an anterior pair of wings (the *elytra*) that are hard and leathery and not used in flight; the membranous hindwings, which are used for flight, are concealed under the elytra when the organisms are at rest. Only 10% of the 350,000 described species of beetles are aquatic.

Beetles are holometabolous. Eggs of aquatic coleopterans hatch in 1 or 2 weeks, with diapause occurring rarely. Larvae undergo from three to eight molts. The pupal phase of all coleopterans is technically terrestrial, making this life stage of beetles the only one that has not successfully invaded the aquatic habitat. A few species have diapausing prepupae, but most complete transformation to adults in 2 to 3 weeks. Terrestrial adults of aquatic beetles are typically short lived and

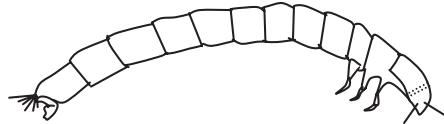

Figure 1.21 Riffle beetle larvae.

sometimes nonfeeding, like those of the other orders of aquatic insects. The larvae of Coleoptera are morphologically and behaviorally different from the adults, and their diversity is high.

Aquatic species occur in two major suborders, the Adepaga and the Polyphaga. Both larvae and adults of six beetle families are aquatic: Dytiscidae (predaceous diving beetles), Elmidae (riffle beetles), Gyrinidae (whirligig beetles), Halipidae (crawling water beetles), Hydrophilidae (water scavenger beetles), and Noteridae (burrowing water beetles). Five families, Chrysomelidae (leaf beetles), Limnichidae (marsh-loving beetles), Psephenidae (water pennies), Ptilodactylidae (toe-winged beetles), and Scirtidae (marsh beetles) have aquatic larvae and terrestrial adults, as do most of the other orders of aquatic insects; adult limnichids, however, readily submerge when disturbed. Three families have species that are terrestrial as larvae and aquatic as adults, a highly unusual combination among insects: Curculionidae (weevils), Dryopidae (long-toed water beetles), and Hydraenidae (moss beetles). Because they provide a greater understanding of the condition of a freshwater body (i.e., they are useful indicators of water quality), we focus our discussion here on the riffle beetle, water penny, and whirligig beetle.

Riffle beetle larvae (most commonly found in running waters, hence their name) are up to 3/4 inches long (see Figure 1.21). The beetle's body is not only long but also hard, stiff, and segmented. They have six long segmented legs on the upper middle section of the body; the back end has two tiny hooks and short hairs. Larvae may take 3 years to mature before they leave the water to form a pupa; adults return to the stream. Riffle beetle adults are considered better indicators of water quality than larvae because they have been subjected to water quality conditions over a longer period. They walk very slowly under the water (on the stream bottom) and do not swim on the surface. They have small oval-shaped bodies (see Figure 1.22) and are typically about 1/4 inch in

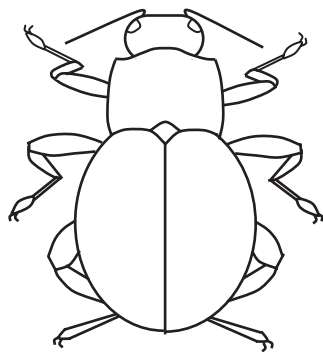

Figure 1.22 Riffle beetle adult.

length. Both adults and larvae of most species feed on fine detritus with associated microorganisms scraped from the substrate, although others may be xylophagous—that is, wood eating (e.g., *Lara*, Elmidae). Predators do not seem to include riffle beetles in their diet, except perhaps for eggs, which are sometimes attacked by flatworms.

The adult *water penny* is inconspicuous and often found clinging tightly in a sucker-like fashion to the undersides of submerged rocks, where

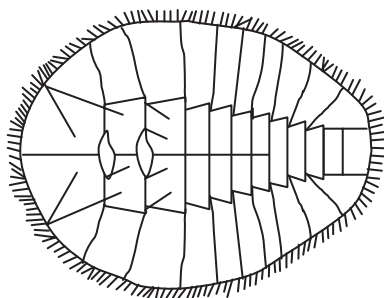

Figure 1.23 Water penny larva.

they feed on attached algae. The body is broad, slightly oval, and flat in shape, ranging from 4 to 6 mm (about 1/4 inch) in length. The body is covered with segmented plates and looks like a tiny round leaf (see Figure 1.23). It has six tiny jointed legs (underneath). The color ranges from light brown to almost black. There are 14 water penny species in the United States. They live predominately in clean, fast-moving streams. Aquatic larvae live a year or more; the terrestrial adults survive on land for only a few days. Water pennies scrape algae and plants from surfaces.

Whirligig beetles are common inhabitants of streams and normally are found on the surface of quiet pools. The body of a whirligig beetle has pincher-like mouthparts and six segmented legs on the middle of the body; the legs end in tiny claws. Many filaments extend from the sides of the abdomen. They have four hooks at the end of the body and no tail (see Figure 1.24).

Note: When disturbed, whirligig beetles swim erratically or dive while emitting defensive secretions.

As larvae, they are benthic predators, whereas the adults live on the water surface, attacking dead and living organisms trapped in the surface film. They occur on the surface in aggregations of up to thousands of individuals. Unlike the mating swarms of mayflies, these aggregations serve primarily to confuse predators. Whirligig beetles have other interesting defensive adaptations—for example, the Johnston's organ at the base of the antennae enables them to echolocate using surface-wave signals. Their compound eyes are divided into two pairs, one above and one below the water surface, enabling them to detect both aerial and aquatic predators, and they produce noxious chemicals that are highly effective at deterring predatory fish.

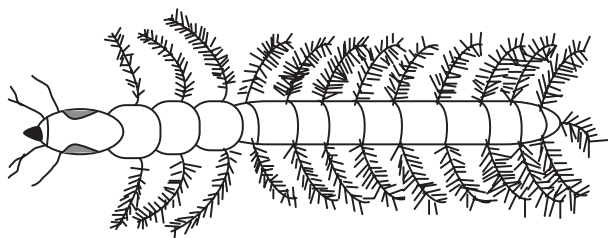

Figure 1.24 Whirligig beetle larva.

1.17.1.6 Water Strider (“Jesus Bugs”) (Order: Hemiptera)

It is fascinating to sit on a log at the edge of a stream pool and watch the drama that unfolds among the small water animals. Among the star performers in small streams are the water bugs. These are aquatic members of that large group of insects known as the “true bugs,” most of which live on land. Moreover, unlike many other types of water insects, they do not have gills but get their oxygen directly from the air. Most conspicuous and commonly known are the *water striders* or *water skaters*. These ride the top of the water, with only their feet making dimples in the surface film.

Like all insects, the water strider has a three-part body (head, thorax, and abdomen), six jointed legs, and two antennae. It has a long, dark, narrow body (see Figure 1.25). The underside of the body is covered with water-repellent hair. Some water striders have wings, others do not. Most water striders are over 5 mm (0.2 inch) long. Water striders eat small insects that fall on the surface of the water and larvae.

Water striders are very sensitive to motion and vibrations on the surface of the water. It uses this ability to locate prey. It pushes its mouth into its prey, paralyzes it, and sucks the insect dry. Predators of the water strider, such as birds, fish, water beetles, backswimmers, dragonflies, and spiders, take advantage of the fact that water striders cannot detect motion above or below the surface of the water.

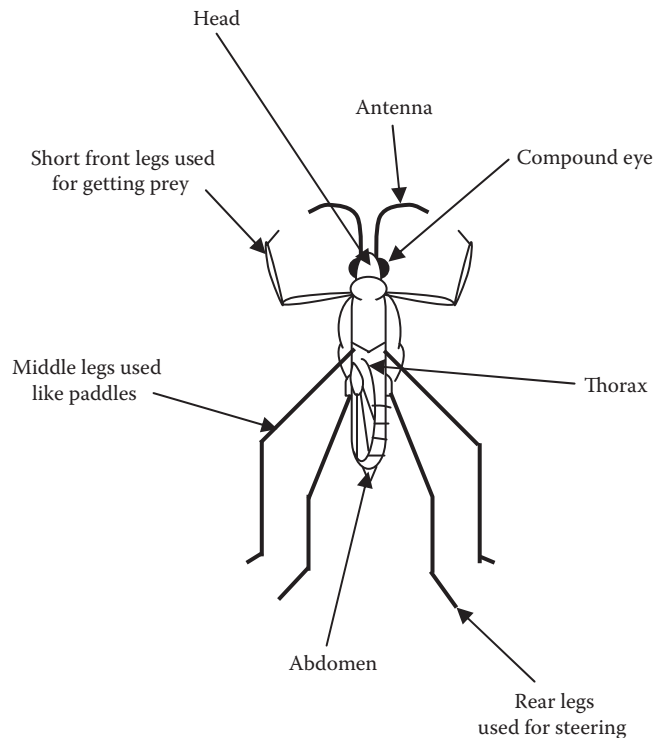

Figure 1.25 Water strider.

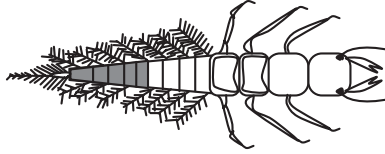

Figure 1.26 Alderfly larva.

1.17.1.7 Alderflies and Dobsonflies (Order: Megaloptera)

Larvae of all species of Megaloptera (“large wing”) are aquatic and attain the largest size of all aquatic insects. Megaloptera is a medium-sized order with less than 5000 species worldwide. Most species are terrestrial; in North America, 64 aquatic species occur. In running waters, alderflies (Family: Sialidae) and dobsonflies (Family: Corydalidae; sometimes called *hellgrammites* or *toe biters*) are particularly important, as they are voracious predators, having large mandibles with sharp teeth.

Alderfly brownish-colored larvae possess a single tail filament with distinct hairs. The body is thick skinned, with six to eight filaments on each side of the abdomen; gills are located near the base of each filament. The mature body size is 0.5 to 1.25 inches (see Figure 1.26). Larvae are aggressive predators, feeding on other adult aquatic macroinvertebrates (they swallow their prey without chewing); as secondary consumers, other larger predators eat them. Female alderflies deposit eggs on vegetation that overhangs water; when the larvae hatch they fall directly into the quiet but moving water. Adult alderflies are dark with long wings folded back over the body; they live only a few days.

Dobsonfly larvae are extremely ugly (thus, they are rather easy to identify) and can be rather large, anywhere from 25 to 90 mm (1 to 3 inches) in length. The body is stout, with eight pairs of appendages on the abdomen. Brush-like gills at the base of each appendage look like hairy armpits (see Figure 1.27). The elongated body has spiracles (spines), three pairs of walking legs near the upper body, and one pair of hooked legs at the rear. The head bears four segmented antennae, small compound eyes, and strong mouth parts (large chewing pinchers). Coloration varies from yellowish, brown, gray, to black, often mottled. Dobsonfly larvae, commonly known as *hellgrammites*, are customarily found along stream banks under and between stones. As indicated by the mouthparts, they are predators and feed on all kinds of aquatic organisms.

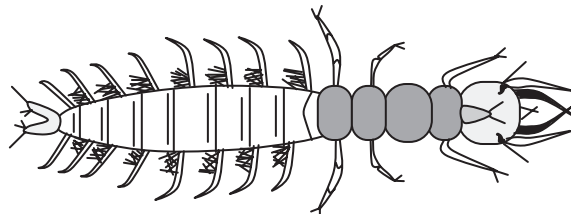

Figure 1.27 Dobsonfly larva.

1.17.1.8 Dragonflies and Damselflies (Order: Odonata)

The order Odonata, which includes dragonflies (Suborder: Anisoptera) and damselflies (Suborder: Zygoptera), is a small order of conspicuous, hemimetabolous insects (lacking a pupal stage) representing about 5000 named species and 23 families worldwide. *Odonata* is a Greek word meaning “toothed one.” It refers to the serrated teeth located on the insect’s chewing mouthparts (mandibles). Characteristics of dragonfly and damselfly larvae include:

- Large eyes
- Three pairs of long segmented legs on the upper middle section (thorax) of body
- Large scoop-like lower lip that covers the bottom of the mouth
- No gills on the sides or underneath the abdomen

Note: Dragonflies and damselflies are unable to fold their four elongated wings back over the abdomen when at rest.

Dragonflies and damselflies are medium to large insects with two pairs of long equal-sized wings. The body is long and slender, with short antennae. Immature stages are aquatic, and development occurs in three stages (egg, nymph, adult).

Dragonflies are also known as *darning needles* (at one time, children were warned to keep quiet or the dragonfly’s darning needles would sew the child’s mouth shut). In their nymphal stage, dragonflies are grotesque creatures, robust and stoutly elongated. They do not have long tails (see Figure 1.28). They are commonly gray, greenish, or brown to black in color. They are medium to large aquatic insects, ranging in size from 15 to 45 mm; the legs are short and used for perching. They are often found on submerged vegetation and at the bottom of streams in the shallows. They are rarely found in polluted waters. Their food consists of other aquatic insects, annelids, small crustacea, and mollusks. Transformation occurs when the nymph crawls out of the water, usually onto vegetation. There it splits its skin and emerges prepared for flight. The adult dragonfly is a strong flier, capable of great speed (>60 mph)

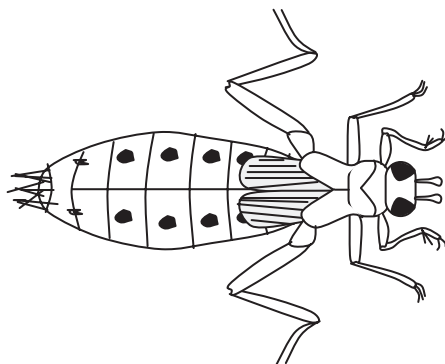

Figure 1.28 Dragonfly nymph.

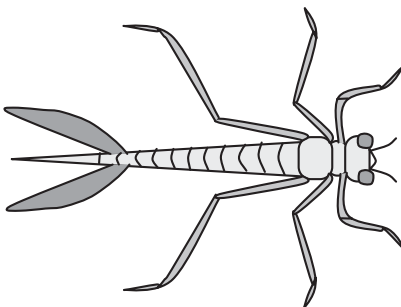

Figure 1.29 Damselfly nymph.

and maneuverability. (They can fly backward, stop on a dime, zip 20 feet straight up, and slip sideways in the blink of an eye!) When at rest the wings remain open and out to the sides of the body. A dragonfly's freely movable head has large, hemispherical eyes (nearly 30,000 facets each), which the insects use to locate prey with their excellent vision.

Dragonflies eat small insects, mainly mosquitoes (large numbers of mosquitoes) while in flight. Depending on the species, dragonflies lay hundreds of eggs by dropping them into the water and leaving them to hatch or by inserting eggs singly into a slit in the stem of a submerged plant. The incomplete metamorphosis (egg, nymph, mature nymph, and adult) can take 2 to 3 years. Nymphs are often covered by algal growth.

Note: Adult dragonflies are sometimes referred to as *mosquito hawks* because they eat such a large number of mosquitoes that they catch while they are flying.

Damselflies are smaller and more slender than dragonflies. They have three long, oar-shaped feathery tails, which are actually gills, and long slender legs (see Figure 1.29). They are gray, greenish, or brown to black in color. Their habits are similar to those of dragonfly nymphs, and they emerge from the water as adults in the same manner. The adult damselflies are slow and seem uncertain in flight. Wings are commonly black or clear, and the body is often brilliantly colored. When at rest, they perch on vegetation with their wings closed upright. Damselflies mature in 1 to 4 years. Adults live for a few weeks or months. Unlike the dragonflies, adult damselflies rest with their wings held vertically over their backs. They mostly feed on live insect larvae.

Note: Relatives of the dragonflies and damselflies are some of the most ancient of the flying insects. Fossils have been found of giant dragonflies with wingspans up to 720 mm that lived long before the dinosaurs!

1.17.2 Non-Insect Macroinvertebrates

Non-insect macroinvertebrates are important to our discussion of stream and freshwater ecology because many of them are used as bioindicators of stream quality. Three frequently encountered groups in running water systems are Oligochaeta (worms), Hirudinea (leeches), and

Gastropoda (lung-breathing snails). They are by no means restricted to running-water conditions, and the great majority of them occupy slow-flowing marginal habitats where the sedimentation of fine organic materials takes place.

1.17.2.1 *Oligochaeta* (Family *Tubificidae*, Genus *Tubifex*)

Tubifex worms (commonly known as sludge worms) are unique in the fact that they build tubes. Sometimes we might find as many as 8000 individuals per square meter. They attach themselves within the tube and wave their posterior end in the water to circulate the water and make more oxygen available to their body surface. These worms are commonly red, because their blood contains hemoglobin. *Tubifex* worms may be very abundant in situations when other macroinvertebrates are absent; they can survive in very low oxygen levels and can live with no oxygen at all for short periods. They are commonly found in polluted streams and feed on sewage or detritus.

1.17.2.2 *Hirudinea* (Leeches)

Despite the many different families of leeches, they all have common characteristics. They are soft-bodied, worm-like creatures that are flattened when extended. Their bodies are dull in color, ranging from black to brown and reddish to yellow, often with a brilliant pattern of stripes or diamonds on the upper body. Their size varies within species but generally ranges from 5 mm to 45 cm when extended. Leeches are very good swimmers, but they typically move in an inchworm fashion. They are carnivorous and feed on other organisms, ranging from snails to warm-blooded animals. Leeches are found in warm protected shallows under rocks and other debris.

1.17.2.3 *Gastropoda* (Lung-Breathing Snail)

Lung-breathing snails (pulmonates) may be found in streams that are clean; however, their dominance may indicate that dissolved oxygen levels are low. These snails are different from *right-handed snails* because they do not breathe under water by use of gills but instead have a lung-like sac called a *pulmonary cavity*, which they fill with air at the surface of the water. When the snail takes in air from the surface, it makes a clicking sound. The air taken in can enable the snail to breathe under water for long periods, sometimes hours.

Lung-breathing snails have two characteristics that help us to identify them. First, they have no operculum or hard cover over the opening to the body cavity. Second, snails are either right-handed or left-handed; the lung-breathing snails are left-handed. We can tell the difference by holding the shell so that its tip is upward and the opening toward us. If the opening is to the left of the axis of the shell, the snail is considered to be *sinistral*—that is, it is left-handed. If the opening is to the right of the axis of the shell, the snail is *dextral*—that is, it is right-handed and

it breathes with gills. Snails are animals of the substrate and are often found creeping along on all types of submerged surfaces in water from 10 cm to 2 m deep.

Before the Industrial Revolution of the 1800s, metropolitan areas were small and sparsely populated; thus, river and stream systems within or next to early communities received insignificant quantities of discarded waste. Early on, these river and stream systems were able to compensate for the small amount of wastes they received; when wounded (polluted), nature has a way of fighting back. In the case of rivers and streams, nature gives these flowing waters the ability to restore themselves through their own self-purification process. It was only when humans gathered in great numbers to form sprawling cities that the stream systems were not always able to recover from receiving great quantities of refuse and other wastes. What exactly is it that we are doing to rivers and streams? We are upsetting the delicate balance between pollution and the purification process; that is, we are unbalancing the aquarium.

1.18 SUMMARY OF KEY TERMS

Abiotic factor is the nonliving part of the environment composed of sunlight, soil, mineral elements, moisture, temperature, topography, minerals, humidity, tide, wave action, wind, and elevation.

Note: Every community is influenced by a particular set of abiotic factors. Whereas it is true that the abiotic factors affect the community members, it is also true that the living (biotic) factors may influence the abiotic factors; for example, the amount of water lost through the leaves of plants may add to the moisture content of the air. Also, the foliage of a forest reduces the amount of sunlight that penetrates the lower regions of the forest. The air temperature is therefore much lower than in unshaded areas (Tomera, 1989).

Autotroph (green plants) fix the energy of the sun and manufacture food from simple, inorganic substances.

Biogeochemical cycles are the cyclic mechanisms in all ecosystems by which biotic and abiotic materials are constantly exchanged.

Biotic factor (community) is the living part of the environment composed of organisms that share the same area; they are mutually sustaining, interdependent, and constantly fixing, utilizing, and dissipating energy.

Community, in an ecological sense, includes all of the populations occupying a given area.

Consumers and *decomposers* dissipate energy fixed by the producers through food chains or webs. The available energy decreases by 80 to 90% during transfer from one trophic level to another.

Ecology is the study of the interrelationship of an organism or a group of organisms and their environment.

Ecosystem is the community and the nonliving environment functioning together as an ecological system.

Environment is everything that is important to an organism in its surroundings.

Heterotrophs (animals) use food stored by the autotroph, rearrange it, and finally decompose complex materials into simple inorganic compounds. Heterotrophs may be carnivorous (meat-eaters), herbivorous (plant-eaters), or omnivorous (plant- and meat-eaters).

Homeostasis is a natural occurrence during which an individual population or an entire ecosystem regulates itself against negative factors and maintains an overall stable condition.

Niche is the role that an organism plays in its natural ecosystem, including its activities, resource use, and interaction with other organisms.

Pollution is an adverse alteration to the environment by a pollutant.

1.19 CHAPTER REVIEW QUESTIONS

- 1.1 The major ecological unit is _____.
- 1.2 Those organisms residing with or on the bottom sediment are _____.
- 1.3 Organisms attached to plants or rocks are referred to as _____.
- 1.4 Small plants and animals that move about with the current are _____.
- 1.5 Free-swimming organisms belong to which group of aquatic organisms?
- 1.6 Organisms that live on the surface of the water are _____.
- 1.7 Movement of new individuals into a natural area is referred to as _____.
- 1.8 What fixes the energy of the sun and makes food from simple inorganic substances?
- 1.9 The freshwater habitat that is characterized by normally clean water is _____.
- 1.10 The amount of oxygen dissolved in water and available for organisms is the _____.

REFERENCES AND RECOMMENDED READING

Barlocher, R. and Kendrick, L. (1975). Leaf conditioning by microorganisms. *Oecologia*, 20, 359–362.

Benfield, E.F. (1996). Leaf breakdown in streams ecosystems. In *Methods in Stream Ecology*, Hauer, F.R. and Lamberti, G.A., Eds., pp. 579–590. San Diego, CA: Academic Press.

- Benfield, E.F., Jones, D.R., and Patterson, M.F. (1977). Leaf pack processing in a pastureland stream. *Oikos*, 29, 99–103.
- Benjamin, C.L., Garman, G.R., and Funston, J.H. (1997). *Human Biology*. New York: McGraw-Hill.
- Carson, R. (1962). *Silent Spring*. Boston: Houghton Mifflin.
- Clements, E.S. (1960). *Adventures in Ecology*. New York: Pageant Press.
- Crossley, Jr., D.A. et al. (1984). The positive interactions in agroecosystems. In *Agricultural Ecosystems*, Lowrance, R., Stinner, B.R., and House, G.J., Eds. New York: John Wiley & Sons.
- Cummins, K.W. (1974). Structure and function of stream ecosystems. *Bioscience*, 24, 631–641.
- Cummins, K.W. and Klug, M.J. (1979). Feeding ecology of stream invertebrates. *Annu. Rev. Ecol. System.*, 10, 631–641.
- Darwin, C. (1998). *The Origin of Species*, Suriano, G., Ed. New York: Grammercy.
- Dolloff, C.A. and Webster, J.R. (2000). Particulate organic contributions from forests to streams: debris isn't so bad. In *Riparian Management in Forests of the Continental Eastern United States*, Verry, E.S., Hornbeck, J.W., and Dolloff C.A., Eds. Boca Raton, FL: CRC Press.
- Evans, F.C. (1956). Ecosystem as the basic unit in ecology. *Science*, 23, 1127–1128.
- Krebs, C.H. (1972). *Ecology: The Experimental Analysis of Distribution and Abundance*. New York: Harper & Row.
- Lindeman, R.L. (1942). The trophic–dynamic aspect of ecology. *Ecology*, 23, 399–418.
- Margulis, L. and Sagan, D. (1997). *Microcosmos: Four Billion Years of Evolution from Our Microbial Ancestors*. Berkeley: University of California Press.
- Marshall, P. (1950). *Mr. Jones, Meet the Master*. Grand Rapids, MI: Fleming H. Revel Co.
- Odum, E.P. (1952). *Fundamentals of Ecology*, 1st ed. Philadelphia, PA: Saunders.
- Odum, E.P. (1971). *Fundamentals of Ecology*, 3rd ed. Philadelphia, PA: Saunders.
- Odum, E.P. (1983). *Basic Ecology*. Philadelphia, PA: Saunders.

Odum, E.P. (1984). Properties of agroecosystems. In *Agricultural Ecosystems*, Lowrance, R., Stinner, B.R., and House, G.J., Eds. New York: John Wiley & Sons.

Odum, E.P. and Barrett, G.W. (2005). *Fundamentals of Ecology*, 5th ed. Belmont, CA: Thomson Brooks/Cole.

Paul, Jr., R.W., Benfield, E.F., and Cairns, Jr., J. (1978). Effects of thermal discharge on leaf decomposition in a river ecosystem. *Verhandlungen der Internationalen Vereinigung für Theoretische und Angewandte Limnologie*, 20, 1759–1766.

Peterson, R.C. and Cummins, K.W. (1974). Leaf processing in woodland streams. *Freshwater Biol.*, 4, 345–368.

Porteous, A. (1992). *Dictionary of Environmental Science and Technology*. New York: John Wiley & Sons.

Ramalay, F. (1940). The growth of a science. *University of Colorado Studies*, 26, 3–14.

Smith, R.L. (1996). *Ecology and Field Biology*. New York: HarperCollins.

Smith, T.M. and Smith, R.L. (2006). *Elements of Ecology*, 6th ed. San Francisco, CA: Pearson, Benjamin Cummings.

Spellman, F.R. (1996). *Stream Ecology and Self-Purification*. Lancaster, PA: Technomic.

Suberkoop, K., Godshalk, G.L., and Klug, M.J. (1976). Changes in the chemical composition of leaves during processing in a woodland stream. *Ecology*, 57, 720–727.

Tansley, A.G. (1935). The use and abuse of vegetational concepts and terms. *Ecology*, 16, 284–307.

Tomera, A.N. (1989). *Understanding Basic Ecological Concepts*. Portland, ME: J. Weston Walch, Publisher.

USDA. (1982). *Agricultural Statistics 1982*. Washington, D.C.: U.S. Department of Agriculture.

USDA. (1999). *Autumn Colors—How Leaves Change Color*. Washington, D.C.: U.S. Department of Agriculture (http://www.na.fs.fed.us/spfo/pubs/misc/autumn/autumn_colors.htm).

USDA. (2007). *Agricultural Ecosystems and Agricultural Ecology*. Washington, D.C.: U.S. Department of Agriculture (<http://nrce.usda.gov/technical/ECS/agecol/ecosystem.html>).

USFWS. (2007). *Ecosystem Conservation*. Washington, D.C.: U.S. Fish & Wildlife Service (<http://www.fws.gov/ecosystems/>).

BASIC WATER CHEMISTRY

Chemical testing can be divided into two types. The first type measures a bulk physical property of the sample, such as volume, temperature, melting point, or mass. These measurements are normally performed with an instrument, and one simply has to calibrate the instrument to perform the test. Most analyses, however, are of the second type, in which a chemical property of the sample is determined that generates information about how much of what is present.

Smith (1993)

Although no one has seen a water molecule, we have determined through x-rays that atoms in water are elaborately meshed. Moreover, although it is true that we do not know as much as we need to know about water (our growing knowledge of water is a work in progress), we have determined many things about water. A large amount of our current knowledge comes from studies of water chemistry.

Water chemistry is important because several factors about water to be treated and then distributed or returned to the environment are determined through simple chemical analysis. Probably the most important determination that the water practitioner makes about water is its hardness.

Why chemistry? "I'm not a chemist," you say. But, when you add chlorine to water to make it safe to drink or safe to discharge into a receiving body (usually a river or lake), you *are* a chemist. Chemistry is the study of substances and the changes they undergo. Water specialists and those interested in the study of water must possess a fundamental knowledge of chemistry. Before beginning our discussion of water chemistry, it is important for the reader to have some basic understanding of chemistry concepts and chemical terms. The following section presents a review of chemistry terms, definitions, and concepts.

2.1 CHEMISTRY CONCEPTS AND DEFINITIONS

Chemistry, like the other sciences, has its own language; thus, to understand chemistry, it is necessary to understand the following concepts and key terms.

2.1.1 Concepts

2.1.1.1 *Miscible and Solubility*

Substances that are *miscible* are capable of being mixed in all proportions. Simply, when two or more substances disperse themselves uniformly in all proportions when brought into contact, they are said to be completely soluble in one another, or completely miscible. The precise chemistry definition is a “homogeneous molecular dispersion of two or more substances” (Jost, 1992). Examples include the following:

- All gases are completely miscible.
- Water and alcohol are completely miscible.
- Water and mercury (in its liquid form) are immiscible liquids.

Between the two extremes of miscibility is a range of *solubility*; that is, various substances mix with one another up to a certain proportion. In many environmental situations, a rather small amount of a contaminant may be soluble in water in contrast to the complete miscibility of water and alcohol. The amounts are measured in parts per million (ppm).

2.1.1.2 *Suspension, Sediment, Particles, and Solids*

Often water carries *solids* or *particles* in suspension. These dispersed particles are much larger than molecules and may be comprised of millions of molecules. The particles may be suspended in flowing conditions and initially under quiescent conditions, but eventually gravity causes settling of the particles. The resultant accumulation by settling is often referred to as *sediment* or *biosolids* (sludge) or *residual solids* in wastewater treatment vessels. Between this extreme of readily falling out by gravity and permanent dispersal as a solution at the molecular level are intermediate types of dispersion or suspension. Particles can be so finely milled or of such small intrinsic size as to remain in suspension almost indefinitely and in some respects similarly to solutions.

2.1.1.3 *Emulsion*

An *emulsion* represents a special case of a suspension. As you know, oil and water do not mix. Oil and other hydrocarbons derived from petroleum generally float on water with negligible solubility in water. In many instances, oils may be dispersed as fine oil droplets (an emulsion) in water and not readily separated by floating because of size or the

addition of dispersal promoting additives. Oil and, in particular, emulsions can prove detrimental to many treatment technologies and must be treated in the early steps of a multistep treatment train.

2.1.1.4 Ion

An *ion* is an electrically charged particle; for example, sodium chloride or table salt forms charged particles on dissolution in water. Sodium is positively charged (a cation), and chloride is negatively charged (an anion). Many salts similarly form cations and anions on dissolution in water.

2.1.1.5 Mass Concentration

Concentration is often expressed in terms of parts per million (ppm) or milligrams per liter (mg/L). Sometimes parts per thousand (ppt) or parts per billion (ppb) are also used:

$$\text{Concentration (ppm)} = \frac{\text{Mass of Substance}}{\text{Mass of Solutions}} \quad (2.1)$$

Because 1 kg of solution with water as a solvent has a volume of approximately 1 liter,

$$1 \text{ ppm} \approx 1 \text{ mg/L}$$

2.1.2 Definitions

Anion—A negative charged ion.

Atom—The smallest particle of an element that can unite chemically with other elements. All atoms of an element are the same with regard to chemical behavior, although they may differ slightly in weight. Most atoms can combine chemically with other atoms to form molecules.

Cation—A positive charged ion.

Chemistry—The science that deals with the composition and changes in composition of substances. Water, for example, is composed of two gases, hydrogen and oxygen. Water also changes form from liquid to solid to gas but does not necessarily change composition.

Colloidal—Refers to any substance in a certain state of fine division in which the particles are less than 1 micron (μm) in diameter.

Compound—A substance of two or more chemical elements combined chemically. Examples include water, which is a compound formed by hydrogen and oxygen (H_2O). Carbon dioxide is composed of carbon and oxygen (CO_2).

Dissolved solids—The material in water that will pass through a glass fiber filter and remain in an evaporating dish after evaporation of the water.

Element—The simplest form of chemical matter. Each element has chemical and physical characteristics different from all other kinds of matter.

Gas—Having neither definite volume nor shape, a gas completely fills any container in which it is placed.

Inorganic—Refers to chemical substances of mineral origin.

Ion—An atom or group of atoms that carries a positive or negative electric charge as a result of having lost or gained one or more electrons.

Ionization—The formation of ions by splitting of molecules or electrolytes in solution. Water molecules are in continuous motion, even at lower temperatures. When two water molecules collide, a hydrogen ion is transferred from one molecule to the other. The water molecule that loses the hydrogen ion becomes a negatively charged hydroxide ion. The water molecule that gains the hydrogen ion becomes a positively charged hydronium ion. This process is commonly referred to as the *self-ionization* of water.

Liquid—Having a definite volume but not shape, a liquid will fill containers to certain levels and form free level surfaces.

Matter—Anything that has weight (mass) and occupies space. Kinds of matter include elements, compounds, and mixtures.

Mixture—A physical, not chemical, intermingling of two or more substances. Sand and salt stirred together form a mixture.

Molecule—The smallest particle of matter or a compound that possesses the same composition and characteristics as the rest of the substance. A molecule may consist of a single atom, two or more atoms of the same kind, or two or more atoms of different kinds.

Organic—Refers to chemical substances of animal or vegetable origin with a carbon structure.

Precipitate—A solid substance that can be dissolved but is separated from solution because of a chemical reaction or change in conditions such as pH or temperature.

Radical—Two or more atoms that unite in a solution and behave chemically as if a single atom.

Saturated solution—The physical state in which a solution will no longer dissolve more of the dissolving substance (solute).

Solids—Substances that maintain a definite size and shape; as pertains to water, solids are suspended and dissolved material in water. Solids in water fall into one of the following categories:

- **Dissolved solids**, which are in solution and pass through a filter. The solution consisting of the dissolved components and water forms a single phase (a homogeneous solution).
- **Colloidal solids (sols)**, which are uniformly dispersed in solution. They form a solid phase that is distinct from the water phase.

- *Suspended solids*, which are also a separate phase from the solution. Some suspended solids are classified as settleable solids. Settleable solids are determined by placing a sample in a cylinder and measuring the amount of solids that have settled after a set amount of time. The size of solids increases moving from dissolved solids to suspended solids.

Solute—The component of a solution that is dissolved by the solvent.

Solvent—The component of a solution that does the dissolving.

Suspended solids—The quantity of material deposited when a quantity of water, sewage, or other liquid is filtered through a glass fiber filter.

Total solids—The solids in water, sewage, or other liquids, including suspended solids (largely removable by a filter) and filterable solids (those that pass through the filter).

Turbidity—A condition in water caused by the presence of suspended matter, turbidity results in the scattering and absorption of light rays.

2.2 CHEMISTRY FUNDAMENTALS

Whenever water and wastewater practitioners add a substance to another substance (from adding sugar to a cup of tea to adding chlorine to water to make it safe to drink) they perform chemistry. Water and wastewater operators (as well as many others) are chemists, because they are working with chemical substances, and it is important for operators to know and to understand how those substances react.

2.2.1 Matter

Going through a day without coming in contact with many kinds of matter is impossible. Paper, coffee, gasoline, chlorine, rocks, animals, plants, water, air—all the materials of which the world is made—are all different forms or kinds of matter. Earlier, matter was defined as anything that has mass (weight) and occupies space; matter is distinguishable from empty space by its presence. Thus, obviously, the statement about the impossibility of going through a day without coming into contact with matter is correct; in fact, avoiding some form of matter is virtually impossible.

Not all matter is the same, even though we narrowly classify all matter into three groups: solids, liquids, and gases. These three groups are the *physical states of matter* and are distinguishable from one another by means of two general features: shape and volume.

Note: *Mass* is closely related to the concept of *weight*. On Earth, the weight of matter is a measure of the force with which it is pulled by gravity toward the center of the Earth. As we leave the surface of Earth,

the gravitational pull decreases, eventually becoming virtually insignificant, while the weight of matter accordingly reduces to zero. Yet, the matter still possesses the same amount of mass. Hence, the mass and weight of matter are proportional to each other.

Note: Because matter occupies space, a given form of matter is also associated with a definite volume. Space should not be confused with air, as air is itself a form of matter. *Volume* refers to the actual amount of space that a given form of matter occupies.

Solids have a definite, rigid shape; their particles are closely packed together and stick firmly to each other. A solid does not change its shape to fit a container. Put a solid on the ground and it will keep its shape and volume—it will never spontaneously assume a different shape. Solids also possess a definite volume at a given temperature and pressure.

Liquids maintain a constant volume but change shape to fit the shape of their container; they do not possess a characteristic shape. The particles of the liquid move freely over one another but still stick together enough to maintain a constant volume. Consider a glass of water. The liquid water takes the shape of the glass up to the level it occupies. If we pour the water into a drinking glass, the water takes the shape of the glass; if we pour it into a bowl, the water takes the shape of the bowl. Thus, if space is available, a liquid assumes whatever shape its container possesses. Like solids, liquids possess a definite volume at a given temperature and pressure, and they tend to maintain this volume when they are exposed to a change in either of these conditions.

Gases have no definite fixed shape, and their volume can be expanded or compressed to fill different sizes of containers. When a gas or mixture of gases, such as air, is put into a balloon, for example, it will assume the shape of the balloon. Particles of gases do not stick together at all and move about freely, filling containers of any shape and size. A gas is identified by its lack of a characteristic volume. When confined to a container with nonrigid, flexible walls, for example, the volume that a confined gas occupies depends on the temperature and pressure. When confined to a container with rigid walls, however, the volume of the gas is forced to remain constant.

Internal linkages among its units, including between one atom and another, maintain the constant composition associated with a given substance. These linkages are called *chemical bonds*. When a particular process occurs that involves the making and breaking of these bonds, we say that a *chemical reaction* or a *chemical change* has occurred. Let's take a closer look at both chemical and physical changes of matter.

Chemical changes occur when new substances are formed that have entirely different properties and characteristics. When wood burns or iron rusts, a chemical change has occurred; the linkages—the chemical bonds—are broken. *Physical changes* occur when matter changes its physical properties, such as size, shape, and density, as well as when it changes its state (e.g., from gas to liquid to solid). When ice melts or when a glass window breaks into pieces, a physical change has occurred.

2.2.2 The Content of Matter: The Elements

Matter is composed of pure basic substances. Earth is made up of the fundamental substances of which all matter is composed. Substances that resist attempts to decompose them into simpler forms of matter are called *elements*. To date, more than 100 elements are known to exist. They range from simple, lightweight elements to very complex, heavy-weight elements. Some of these elements exist in nature in pure form; others are combined.

The smallest unit of an element is the *atom*. The simplest atom possible consists of a *nucleus* having a single *proton* and no *neutron* and a single *electron* traveling around the nucleus. This is an atom of hydrogen, which has an atomic weight of one because of the single proton. The *atomic weight* of an element is equal to the total number of protons and neutrons in the nucleus of an atom of an element.

To better understand the basic atomic structure and related chemical principles it is useful to compare the atom to our solar system. In our solar system, the sun is the center of everything, whereas the nucleus is the center in the atom. The sun has several planets orbiting around it, whereas the atom has electrons orbiting about the nucleus. It is interesting to note that astrophysicists, who would likely find this analogy overly simplistic, are concerned primarily with activity within the nucleus. This is not the case, however, with chemists, who deal principally with the activity of the planetary electrons; chemical reactions between atoms or molecules involve only electrons, with no changes in the nuclei.

The nucleus is made up of positive electrically charged protons and neutrons, which are neutral (no charge). The negatively charged electrons orbiting the nucleus balance the positive charge in the nucleus. An electron has negligible mass (less than 0.02% of the mass of a proton), which makes it practical to consider the weight of the atom as the weight of the nucleus.

Atoms are identified by name, atomic number, and atomic weight. The *atomic number* or *proton number* is the number of protons in the nucleus of an atom. It is equal to the positive charge on the nucleus. In a neutral atom, it is also equal to the number of electrons surrounding the nucleus. As mentioned, the atomic weight of an atom depends on the number of protons and neutrons in the nucleus, the electrons having negligible mass. Atoms (elements) have received their names and symbols in interesting ways. The discoverer of the element usually proposes a name for it. Some elements get their symbols from languages other than English. The following is a list of common elements with their common names and the names from which the symbol is derived:

Chlorine	Cl
Copper	Cu (Latin <i>cuprum</i>)
Hydrogen	H
Iron	Fe (Latin <i>ferrum</i>)

Nitrogen	N
Oxygen	O
Phosphorus	P
Sodium	Na (Latin <i>natrium</i>)
Sulfur	S

A capital letter, or a capital letter with a small letter, designates each element. These are called *chemical symbols*. As is apparent from this list, most of the time the symbol is easily recognized as an abbreviation of the atom name, such as O for oxygen.

Typically, we do not find most of the elements as single atoms. They are more often found in combinations of atoms called *molecules*. Basically, a molecule is the least common denominator of what makes a substance what it is. A system of formulae has been devised to show how atoms are combined into molecules. When a chemist writes the symbol for an element, it stands for one atom of the element. A subscript following the symbol indicates the number of atoms in the molecule. O₂ is the chemical formula for an oxygen molecule. It shows that oxygen occurs in molecules consisting of two oxygen atoms. As you know, a molecule of water contains two hydrogen atoms and one oxygen atom, so the formula is H₂O.

Note: H₂O, the chemical formula of the water molecule, was defined in 1860 by the Italian scientist Stanislao Cannizzaro.

Some elements have similar chemical properties; for example, a chemical such as bromine (atomic number 35) has chemical properties that are similar to those for the element chlorine (atomic number 17), with which most water operators are familiar, and iodine (atomic number 53).

In 1865, English chemist John Newlands arranged some of the known elements in an increasing order of atomic weights. Newlands arranged the lightest element known at the time at the top of the list and the heaviest element at the bottom. Newlands was surprised when he observed that starting from a given element, every eighth element repeated the properties of the given element.

Later, in 1869, Mendeleev, a Russian chemist, published a table of the 63 known elements. In his table, Mendeleev, like Newlands, arranged the elements in an increasing order of atomic weights. He also grouped them in eight vertical columns so the elements with similar chemical properties would be found in one column. It is interesting to note that Mendeleev left blanks in his table. He correctly hypothesized that undiscovered elements existed that would fill in the blanks when they were discovered. Because he knew the chemical properties of the elements above and below the blanks in his table, he was able to predict quite accurately the properties of some of the undiscovered elements.

Today our modern form of the periodic table is based on work done by the English scientist Henry Moseley, who was killed during World War I. Following the work of Ernest Rutherford (a New Zealand physicist) and Niels Bohr (a Danish physicist), Moseley used x-ray methods to determine the number of protons in the nucleus of an atom. The atomic number, or number of protons, of an atom is related to its atomic structure. In turn, atomic structure governs chemical properties. The atomic number of an element is more directly related to its chemical properties than is its atomic weight. It is more logical to arrange the periodic table according to atomic numbers than atomic weights. By demonstrating the atomic numbers of elements, Moseley helped chemists to make a better periodic table.

In the periodic table, each box or section contains the atomic number, symbol, and atomic weight of an element. The numbers down the left side of the box show the arrangement, or configuration, of the electrons in the various shells around the nucleus. For example, the element carbon has an atomic number of 6, its symbol is C, and its atomic weight is 12.01.

In the periodic table, a horizontal row of boxes is called a *period* or *series*. Hydrogen is all by itself because of its special chemical properties. Helium is the only element in the first period. The second period contains lithium, beryllium, boron, carbon, nitrogen, oxygen, fluorine, and neon. Other elements may be identified by looking at the table. A vertical column is called a *group* or *family*. Elements in a group have similar chemical properties. The periodic table is useful because knowing where an element is located in the table gives us a general idea of its chemical properties.

As mentioned, for convenience, elements have a specific name and symbol but are often identified by chemical symbol only. The symbols of the elements consist of either one or two letters, with the first letter capitalized. Table 2.1 lists the elements important to the water/wastewater practitioner (about a third of the over 100 elements).

2.2.3 Compound Substances

If we take a pure substance such as calcium carbonate (limestone) and heat it, the calcium carbonate ultimately crumbles to a white powder; however, careful examination of the process shows that carbon dioxide also evolves from the calcium carbonate. Substances such as calcium carbonate that can be broken down into two or more simpler substances are called *compound substances* or simply *compounds*. Heating is a common way of decomposing compounds, but other forms of energy are often used as well. Chemical elements that make up compounds such as calcium carbonate combine with each other in definite proportions. When atoms of two or more elements are bonded together to form a compound, the resulting particle is called a *molecule*.

Key Point: Only a certain number of atoms or radicals of one element will combine with a certain number of atoms or radicals of a different element to form a chemical compound.

**TABLE 2.1 ELEMENTS
AND THEIR SYMBOLS**

Element	Symbol	Element	Symbol
Aluminum ^a	Al	Iron ^a	Fe
Arsenic	As	Lead	Pb
Barium	Ba	Magnesium ^a	Mg
Cadmium	Ca	Manganese ^a	Mn
Carbon ^a	C	Mercury	Hg
Calcium	Ca	Nitrogen ^a	N
Chlorine ^a	Cl	Nickel	Ni
Chromium	Cr	Oxygen ^a	O
Cobalt	Co	Phosphorus	P
Copper	Cu	Potassium	K
Fluoride ^a	F	Silver	Ag
Helium	He	Sodium ^a	Na
Hydrogen ^a	H	Sulfur ^a	S
Iodine	I	Zinc	Zn

^a Indicates elements familiar to water/wastewater treatment operators.

Water (H₂O) is a compound. As stated, compounds are chemical substances made up of two or more elements bonded together. Unlike elements, compounds can be separated into simpler substances by chemical changes. Most forms of matter in nature are composed of combinations of the over 100 pure elements.

If we have a particle of a compound—for example, a crystal of salt (sodium chloride)—and subdivide, subdivide, and subdivide until we get the smallest unit of that compound possible, we would have a molecule. Again, a molecule (or least common denominator) is the smallest particle of a compound that still has the characteristics of that compound.

Note: Because the weights of atoms and molecules are relative and the units are extremely small, the chemist works with units known as *moles*. A mole (symbol, mol) is defined as the amount of a substance that contains as many elementary entities (atoms, molecules, and so on) as there are atoms in 12 g of the isotope carbon-12.

Note: An isotope of an element is an atom having the same structure as the element—the same electrons orbiting the nucleus, and the same protons in the nucleus—but having more or fewer neutrons.

One mole of an element that exists as single atoms weighs as many grams as its atomic number (so one mole of carbon weighs 12 g), and it contains 6.022045×10^{23} atoms, which is the *Avogadro's number*.

As stated previously, symbols are used as a shorthand method for writing the names of the elements. This shorthand method is also used for writing the names of compounds. Symbols used in this manner show the kinds and numbers of different elements in the compound. These shorthand representations of chemical compounds are called chemical

formulae; for example, the formula for table salt (sodium chloride) is NaCl. The formula shows that one atom of sodium combines with one atom of chlorine to form sodium chloride. Let's look at a more complex formula for the compound sodium carbonate (soda ash): Na₂CO₃. The formula shows that this compound is made up of three elements: sodium, carbon, and oxygen. In addition, each molecule has two atoms of sodium, one atom of carbon, and three atoms of oxygen.

When depicting chemical reactions, chemical *equations* are used. The following equation shows a chemical reaction with which most water/wastewater operators are familiar—adding chlorine gas to water. The equation shows the molecules that react together and the resulting product molecules:

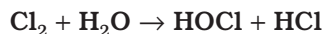

A chemical equation tells us what elements and compounds are present before and after a chemical reaction. Sulfuric acid poured over zinc will cause the release of hydrogen and the formation of zinc sulfate. This is shown by the following equation:

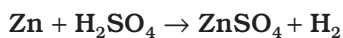

One atom (also one molecule) of zinc unites with one molecule of sulfuric acid to give one molecule of zinc sulfate and one molecule (two atoms) of hydrogen. Notice the same number of atoms of each element on each side of the arrow, even though the atoms are combined differently.

Let us look at another example. When hydrogen gas is burned in air, the oxygen from the air unites with the hydrogen and forms water. The water is the product of burning hydrogen. This can be expressed as an equation:

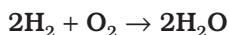

This equation indicates that two molecules of hydrogen unite with one molecule of oxygen to form two molecules of water.

2.3 WATER SOLUTIONS

A *solution* is a condition in which one or more substances are uniformly and evenly mixed or dissolved. A solution has two components, a solvent and a solute. The solvent is the component that does the dissolving. The solute is the component that is dissolved. In water solutions, water is the solvent. Water can dissolve many other substances; in fact, given enough time, not too many solids, liquids, and gases exist that water cannot dissolve. When water dissolves substances, it creates solutions with many impurities. Generally, a solution is usually transparent and not cloudy; however, a solution may have some color when the solute remains uniformly distributed throughout the solution and does not settle with time.

TABLE 2.2 IONS AND THEIR SYMBOLS

Ion	Symbol
Hydrogen	H ⁺
Sodium	Na ⁺
Potassium	K ⁺
Chloride	Cl ⁻
Bromide	Br ⁻
Iodide	I ⁻
Bicarbonate	HCO ₃ ⁻

When molecules dissolve in water, the atoms making up the molecules come apart (dissociate) in the water. This dissociation in water is called *ionization*. When the atoms in the molecules come apart, they do so as charged atoms (both negatively and positively charged), called *ions*. The positively charged ions are *cations*, and the negatively charged ions are *anions*. A good example of the ionization process occurs when calcium carbonate ionizes:

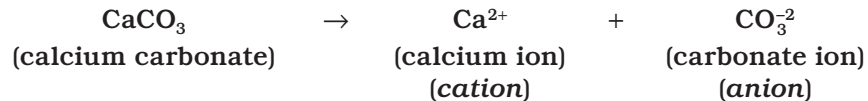

Another good example is the ionization that occurs when table salt (sodium chloride) dissolves in water:

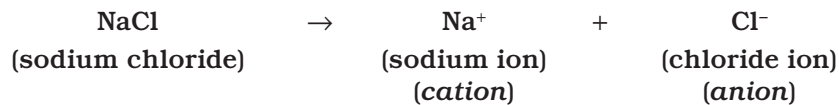

The symbols of some of the common ions found in water are provided in Table 2.2.

Water dissolves polar substances better than nonpolar substances. This makes sense when we consider that water is a polar substance. Polar substances such as mineral acids, bases, and salts are easily dissolved in water, while nonpolar substances such as oils, fats, and many organic compounds do not dissolve easily in water.

Although water dissolves polar substances better than nonpolar substances, polar substances dissolve in water only up to a point; for example, only so much solute will dissolve at a given temperature. When that limit is reached, the resulting solution is saturated. When a solution becomes saturated, no more solute can be dissolved. For solids dissolved in water, if the temperature of the solution is increased, the amount of solids (solutes) required to reach saturation increases.

2.4 WATER CONSTITUENTS

Natural water can contain a number of substances (what we may call *impurities* or constituents in water treatment operations). The concentrations of various substances in water in dissolved, colloidal, or suspended form are typically low but vary considerably. A hardness value of up to 400 ppm of calcium carbonate, for example, is sometimes tolerated in public supplies, whereas 1 ppm of dissolved iron would be unacceptable. When a particular constituent can affect the health of the water user or the environment, it is considered to be a *contaminant* or *pollutant*. These contaminants, of course, are what the water operator works to prevent from entering the water supply. In this section, we discuss some of the more common constituents of water.

2.4.1 Solids

Other than gases, all contaminants of water contribute to the solids content. Natural water carries many dissolved and undissolved solids. The undissolved solids are nonpolar substances and consist of relatively large particles of materials, such as silt, that will not dissolve. Classified by their size and state, by their chemical characteristics, and by their size distribution, solids can be dispersed in water in both suspended and dissolved forms.

Solids in water can be classified based on size as *suspended*, *settleable*, *colloidal*, or *dissolved*. Total solids are those suspended and dissolved solids that remain behind when the water is removed by evaporation. Solids are also characterized as being volatile or nonvolatile.

The distribution of solids is determined by computing the percentage of filterable solids by size range. Solids typically include inorganic solids such as silt and clay from riverbanks and organic matter such as plant fibers and microorganisms from natural or human-made sources.

Though not technically accurate from a chemical point of view because some finely suspended material can actually pass through the filter, *suspended solids* are defined as those that can be filtered out in the suspended solids laboratory test. The material that passes through the filter is defined as *dissolved solids*. *Colloidal solids* are extremely fine suspended solids (particles) of less than 1 μm in diameter; they are so small (though they can still make water cloudy) that they will not settle even if allowed to sit quietly for days or weeks.

2.4.2 Turbidity

Simply, turbidity refers to how clear the water is. The clarity of water is one of the first characteristics people notice. Turbidity in water is caused by the presence of suspended matter, which results in the scattering and absorption of light rays. The greater the amount of total suspended solids (TSS) in the water, the murkier it appears and the

higher the measured turbidity. Thus, in plain English, turbidity is a measure of the light-transmitting properties of water. Natural water that is very clear (low turbidity) allows us to see images at considerable depths. High-turbidity water, on the other hand, appears cloudy. Keep in mind that water of low turbidity is not necessarily without dissolved solids. Dissolved solids do not cause light to be scattered or absorbed, so the water looks clear. High turbidity causes problems for the waterworks operator, as components that cause high turbidity can cause taste and odor problems and will reduce the effectiveness of disinfection.

2.4.3 Color

Color in water can be caused by a number of contaminants, such as iron, which changes in the presence of oxygen to yellow or red sediments. The color of water can be deceiving. In the first place, color is considered an aesthetic quality of water with no direct health impact. Second, many of the colors associated with water are not true colors but the result of colloidal suspension and are referred to as the *apparent color*. This apparent color can often be attributed to iron and to dissolved tannin extracted from decaying plant material. *True color* is the result of dissolved chemicals (most often organics) that cannot be seen. True color is distinguished from apparent color by filtering the sample.

2.4.4 Dissolved Oxygen

Although water molecules contain oxygen atoms, this oxygen is not what is needed by aquatic organism living in our natural waters. A small amount of oxygen, up to about ten molecules of oxygen per million molecules of water, is actually dissolved in water. This dissolved oxygen (DO) is breathed by fish and zooplankton that need it to survive. Other gases can also be dissolved in water. In addition to oxygen, carbon dioxide, hydrogen sulfide, and nitrogen are examples of gases that dissolve in water. Gases dissolved in water are important; for example, carbon dioxide is important because of the role it plays in pH and alkalinity. Carbon dioxide is released into the water by microorganisms and consumed by aquatic plants; however, dissolved oxygen in water is of most importance to us here, not only because it is important to most aquatic organisms but also because dissolved oxygen is an important indicator of water quality.

Like terrestrial life, aquatic organisms need oxygen to live. As water moves past their breathing apparatus, microscopic bubbles of oxygen gas in the water (dissolved oxygen) are transferred from the water to their blood. Like any other gas diffusion process, the transfer is efficient only above certain concentrations. In other words, oxygen can be present in the water, but at too low a concentration to sustain aquatic life. Oxygen also is needed by virtually all algae and macrophytes, as well as for many chemical reactions that are important to water body functioning.

Rapidly moving water, such as in a mountain stream or large river, tends to contain a lot of dissolved oxygen, while stagnant water contains little. Bacteria in water can consume oxygen as organic matter

TABLE 2.3 COMMON METALS FOUND IN WATER

Metal	Health Hazard
Barium	Circulatory system effects and increased blood pressure
Cadmium	Concentration in the liver, kidneys, pancreas, and thyroid
Copper	Nervous system damage and kidney effects; toxic to humans
Lead	Same as copper
Mercury	Central nervous system (CNS) disorders
Nickel	CNS disorders
Selenium	CNS disorders
Silver	Gray skin
Zinc	Taste effects; not a health hazard

decays; thus, excess organic material in our lakes and rivers can cause an oxygen-deficient situation to occur. Aquatic life can have a difficult time surviving in stagnant water that has a lot of rotting, organic material in it, especially in summer, when dissolved oxygen levels are at a seasonal low.

Note: Solutions can become saturated with solute. This is the case with water and oxygen. As with other solutes, the amount of oxygen that can be dissolved at saturation depends on the temperature of the water. In the case of oxygen, the effect is just the opposite of other solutes. The higher the temperature, the lower the saturation level; the lower the temperature, the higher the saturation level.

2.4.5 Metals

Metals are elements, present in chemical compounds as positive ions or in the form of cations (+ ions) in solution. Metals with a density over 5 kg/dm³ are known as *heavy metals*. Metals are one of the constituents or impurities often carried by water. Although most of the metals are not harmful at normal levels, a few metals can cause taste and odor problems in drinking water. In addition, some metals may be toxic to humans, animals, and microorganisms. Most metals enter water as part of compounds that ionize and release the metal as positive ions. Table 2.3 lists some metals commonly found in water and their potential health hazards.

Note: Metals may be found in various chemical and physical forms. These forms, or *species*, can be particles or simple organic compounds, organic complexes, or colloids. The dominant form is determined largely by the chemical composition of the water, the matrix, and in particular the pH.

2.4.6 Organic Matter

Organic compounds contain the element carbon and are derived from material that was once alive (i.e., plants and animals). Organic compounds include fats, dyes, soaps, rubber products, plastics, wood, fuels,

**TABLE 2.4 RELATIVE
STRENGTHS OF ACIDS
IN WATER**

Acid	Formula
Perchloric acid	HClO ₄
Sulfuric acid	H ₂ SO ₄
Hydrochloric acid	HCl
Nitric acid	HNO ₃
Phosphoric acid	H ₃ PO ₄
Nitrous acid	HNO ₂
Hydrofluoric acid	HF
Acetic acid	CH ₃ COOH
Carbonic acid	H ₂ CO ₃
Hydrocyanic acid	HCN
Boric acid	H ₃ BO ₃

cotton, proteins, and carbohydrates. Organic compounds in water are usually large, nonpolar molecules that do not dissolve well in water. They often provide large amounts of energy to animals and microorganisms.

Note: Natural organic matter (NOM) is used to describe the complex mixture of organic material, such as humic and hydrophilic acids, present in all drinking water sources. NOM can cause major problems in the treatment of water as it reacts with chlorine to form disinfection byproducts (DBPs). Many of the disinfection byproducts formed by the reaction of NOM with disinfectants are reported to be toxic and carcinogenic to humans if ingested over an extended period. The removal of NOM and subsequent reduction in DBPs are major goals in the treatment of any water source.

2.4.7 Inorganic Matter

Inorganic matter or compounds are carbon free, not derived from living matter, and easily dissolved in water; they are of mineral origin. The inorganics include acids, bases, oxides, and salts. Several inorganic components are important in establishing and controlling water quality. Two important inorganic constituents in water are nitrogen and phosphorus.

2.4.8 Acids

Lemon juice, vinegar, and sour milk are acidic or contain acid. The common acids used in waterworks operations are hydrochloric acid (HCl), sulfuric acid (H₂SO₄), nitric acid (HNO₃), and carbonic acid (H₂CO₃). Note that in each of these acids, hydrogen (H) is one of the elements. The relative strengths of acids in water (listed in descending order of strength) are classified in Table 2.4. Acids and bases become solvated; that is, they loosely bond to water molecules.

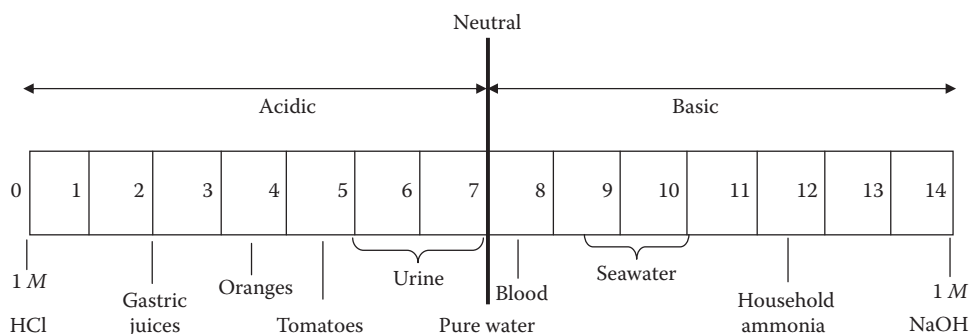

Figure 2.1 pH scale.

Note: An acid is a substance that produces hydrogen ions (H^+) when dissolved in water. Hydrogen ions are hydrogen atoms stripped of their electrons. A single hydrogen ion is nothing more than the nucleus of a hydrogen atom.

2.4.9 Bases

A *base* is a substance that produces hydroxide ions (OH^-) when dissolved in water. Lye or common soap (bitter things) contains bases. The bases used in waterworks operations are calcium hydroxide, $Ca(OH)_2$; sodium hydroxide, $NaOH$; and potassium hydroxide, KOH . Note that the hydroxyl group (OH) is found in all bases. In addition, note that bases contain metallic substances, such as sodium (Na), calcium (Ca), magnesium (Mg), and potassium (K). These bases contain the elements that produce the alkalinity in water.

2.4.10 Salts

When acids and bases chemically interact, they neutralize each other. The compound (other than water) that forms from the neutralization of acids and bases is called a *salt*. Salts constitute, by far, the largest group of inorganic compounds. A common salt used in waterworks operations, copper sulfate, is utilized to kill algae in water.

2.4.11 pH

pH is a measure of the hydrogen ion (H^+) concentration. Solutions range from very acidic (having a high concentration of H^+ ions) to very basic (having a high concentration of OH^- ions). The pH scale ranges from 0 to 14, with 7 being the neutral value (see Figure 2.1). The pH of water is important to the chemical reactions that take place within water, and pH values that are too high or low can inhibit the growth of microorganisms. High pH values are considered basic, and low pH values are considered acidic. Stated another way, low pH values indicate a

high H⁺ concentration, and high pH values indicate a low H⁺ concentration. Because of this inverse logarithmic relationship, there is a tenfold difference in H⁺ concentration.

Natural water varies in pH depending on its source. Pure water has a neutral pH, with equal H⁺ and OH⁻. Adding an acid to water causes additional positive ions to be released, so the H⁺ ion concentration goes up and the pH value goes down:

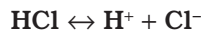

To control water coagulation and corrosion, the waterworks operator must test for the hydrogen ion concentration of the water to determine the pH of the water. In a coagulation test, as more alum (acid) is added, the pH value lowers. If more lime (alkali) is added, the pH value raises. This relationship should be remembered—if a good floc is formed, the pH should then be determined and maintained at that pH value until the raw water changes.

Pollution can change the pH of water, thus harming animals and plants living in the water. Water coming out of an abandoned coal mine can have a pH of 2, which is very acidic and would definitely affect any fish crazy enough to try to live in that water. On the logarithm scale, this mine-drainage water would be 100,000 times more acidic than neutral water—so stay out of abandoned mines.

Note: Seawater is slightly more basic (the pH value is higher) than most natural freshwater. Neutral water (such as distilled water) has a pH of 7, which is in the middle of being acidic and alkaline. Seawater happens to be slightly alkaline (basic), with a pH of about 8. Most natural water has a pH range of 6 to 8, although acid rain can have a pH as low as 4.

2.5 COMMON WATER MEASUREMENTS

Water and wastewater practitioners and regulators, such as waterworks operators and the U.S. Environmental Protection Agency (USEPA), along with their scientific counterparts at the U.S. Geological Survey (USGS), have been measuring water for decades. Millions of measurements and analyses have been made. Some measurements are taken almost every time water is sampled and investigated, no matter where in the United States the water is being studied. Even these simple measurements can sometimes reveal something important about the water and the environment around it.

The USGS (2006) has noted that the results of a single measurement of the properties of water are actually less important than looking at how those properties vary over time. Suppose we take the pH of the river running through our town and find that it is 5.5. We might say, “Wow, the water is acidic!” But, a pH of 5.5 might be normal for that particular river. It is similar to how an adult’s normal body temperature

is about 97.5°F, but a youngster's normal temperature is *really* normal—right on the 98.6°F mark. As with our temperatures, if the pH of a river begins to change, then we might suspect that something is going on somewhere that is affecting the water and possibly the water quality. For this reason, changes in water measurements are more important than the actual measured values.

Up to this point, the important constituents and parameters of turbidity, dissolved oxygen, pH, and others have been discussed, but there are others we should address. In the following, the parameters of alkalinity, water temperature, specific conductance, and hardness are discussed.

2.5.1 Alkalinity

Alkalinity is defined as the capacity of water to accept protons; it can also be defined as a measure of the ability of water to neutralize an acid. Bicarbonates, carbonates, and hydrogen ions cause alkalinity and create hydrogen compounds in a raw or treated water supply. Bicarbonates are the major components because of the actions of carbon dioxide on the basic materials of soil; borates, silicates, and phosphates may be minor components. The alkalinity of raw water may also be due to salts formed from organic acids such as humic acids.

Alkalinity in water acts as a buffer that tends to stabilize and prevent fluctuations in pH. In fact, alkalinity is closely related to pH, but the two must not be confused. Total alkalinity is a measure of the amount of alkaline materials in the water. Alkaline materials act as buffers to changes in the pH. If the alkalinity is too low (below 80 ppm), the pH can fluctuate rapidly because of insufficient buffer. High alkalinity (above 200 ppm) results in the water being too buffered. Thus, having significant alkalinity in water is usually beneficial, because it tends to prevent quick changes in pH that interfere with the effectiveness of common water treatment processes. Low alkalinity also contributes to the corrosive tendencies of water.

Note: Alkalinity below 80 mg/L is considered low.

2.5.2 Water Temperature

Water temperature is important not only to fishermen but also to industries and even fish and algae. A lot of water is used for cooling purposes in power plants that generate electricity. These plants need to cool the water to begin with and then generally release warmer water back to the environment. The temperature of the released water can affect downstream habitats. Temperature can also affect the ability of water to hold oxygen as well as the ability of organisms to resist certain pollutants.

TABLE 2.5 WATER HARDNESS

Classification	mg/L CaCO₃
Soft	0–75
Moderately hard	75–150
Hard	150–300
Very hard	Over 300

2.5.3 Specific Conductance

Specific conductance is a measure of the ability of water to conduct an electrical current. It is highly dependent on the amount of dissolved solids (such as salt) in the water. Pure water, such as distilled water, will have a very low specific conductance, and seawater will have a high specific conductance. Rainwater often dissolves airborne gasses and airborne dust while it is in the air and thus often has a higher specific conductance than distilled water. Specific conductance is an important water quality measurement because it gives a good idea of the amount of dissolved material in the water. When electrical wires are attached to a battery and light bulb and the wires are put into a beaker of distilled water, the light will not light. But, the bulb does light up when the beaker contains saline (salt) water. In saline water, the salt has dissolved, releasing free electrons, and the water will conduct an electric current.

2.5.4 Hardness

Hardness may be considered a physical or chemical characteristic or parameter of water. It represents the total concentration of calcium and magnesium ions, reported as calcium carbonate. Simply, the amount of dissolved calcium and magnesium in water determines its hardness. Hardness causes soaps and detergents to be less effective and contributes to scale formation in pipes and boilers. Hardness is not considered a health hazard; however, water that contains hardness must often be softened by lime precipitation or ion exchange. Hardwater can even shorten the life of fabrics and clothes. Low hardness contributes to the corrosive tendencies of water. Hardness and alkalinity often occur together, because some compounds can contribute both alkalinity and hardness ions. Hardness is generally classified as shown in Table 2.5.

2.5.5 Odor Control (Wastewater Treatment)

There is an old saying in wastewater treatment: “Odor is not a problem until the neighbors complain” (Spellman, 1997). Experience has shown that when treatment plant odor is apparent it is not long before the neighbors do complain. Thus, odor control is an important factor affecting the performance of any wastewater treatment plant, especially with regard to public relations.

In wastewater operations, “the principal sources of odors are from (1) septic wastewater containing hydrogen sulfide and odorous compounds, (2) industrial wastes discharged into the collection system, (3)

screenings and unwanted grit, (4) septage handling facilities, (5) scum on primary settling tanks, (6) organically overloaded treatment processes, (7) [biosolids] thickening tanks, (8) waste gas-burning operations where lower than optimum temperatures are used, (9) [biosolids] conditioning and dewatering facilities, (10) [biosolids] incineration, (11) digested [biosolids] in drying beds or [biosolids] holding basins, and (12) [biosolids] composting operations” (Metcalf & Eddy, 1991).

Odor control can be accomplished by chemical or physical means. Physical means include buffer zones between the process operation and the public, operation changes, controlling discharges to collection systems, containments, dilution, fresh air, adsorption, using activated carbon, and scrubbing towers, among other means.

Odor control by chemical means involves scrubbing with various chemicals, chemical oxidation, and chemical precipitation methods. For *scrubbing with chemicals*, odorous gases are passed through specially designed scrubbing towers to remove odors. The commonly used chemical scrubbing solutions are chlorine and potassium permanganate. When hydrogen sulfide concentrations are high, sodium hydroxide is often used. In *chemical oxidation* applications, the oxidants chlorine, ozone, hydrogen peroxide, and potassium permanganate are used to oxidize the odor compounds. *Chemical precipitation* works to precipitate sulfides from odor compounds using iron and other metallic salts.

2.6 CHAPTER REVIEW QUESTIONS

- 2.1 The chemical symbol for sodium is _____.
- 2.2 The chemical symbol for sulfuric acid is _____.
- 2.3 Neutrality on the pH scale is _____.
- 2.4 Is NaOH a salt or a base?
- 2.5 Chemistry is the study of substances and the _____ they undergo.
- 2.6 The three stages of matter are _____, _____, and _____.
- 2.7 A basic substance that cannot be broken down any further without changing the nature of the substance is _____.
- 2.8 A combination of two or more elements is a _____.
- 2.9 A table of the basic elements is called the _____ table.
- 2.10 When a substance is mixed into water to form a solution, the water is called the _____, and the substance is called the _____.
- 2.11 Define ion.
- 2.12 A solid that is less than 1 μm in size is called a _____.
- 2.13 The property of water that causes light to be scattered and absorbed is _____.

- 2.14 What is true color?
- 2.15 What is the main problem with metals found in water?
- 2.16 Compounds derived from material that once was alive are called _____ chemicals.
- 2.17 pH ranges from _____ to _____.
- 2.18 What is alkalinity?
- 2.19 The two ions that cause hardness are _____ and _____.
- 2.20 What type of substance produces hydroxide ions (OH⁻) in water?

REFERENCES AND RECOMMENDED READING

Greenberg, A.E. et al., Eds. (1999). *Standard Methods for Examination of Water and Wastewater*, 20th ed. Washington, D.C.: American Public Health Association.

Jost, N.J. (1992). Surface and ground water pollution control technology. In *Fundamentals of Environmental Science and Technology*, Knowles, P.-C., Ed. Rockville, MD: Government Institutes, Inc.

McGhee, T.J. (1991). *Water Supply and Sewerage*, 6th ed. New York: McGraw-Hill.

Metcalf & Eddy. (1991). *Wastewater Engineering: Treatment, Disposal, Reuse*, 3rd ed. New York: McGraw-Hill.

Mullenix, P.J. (1997). Letter to the Operations and Environmental Committee, City of Calgary, Canada.

Smith, R.K. (1993). *Water and Wastewater Laboratory Techniques*. Alexandria, VA: Water Environment Federation.

Spellman, F.R. (1997). *Wastewater Biosolids to Compost*. Boca Raton, FL: CRC Press.

Tchobanoglous, G. and Schroeder E.D. (1987). *Water Quality*. Reading, MA: Addison-Wesley.

USGS. (2006). *Water Science for Schools: Water Measurements*. Washington, D.C.: U.S. Geological Survey.

Watson, L. (1988). *The Water Planet: A Celebration of the Wonder of Water*. New York: Crown Publishers.

BLUEPRINT READING

You have heard the old saying, “A picture is worth a thousand words.” This is certainly true when referring to wastewater unit processes, plant process machinery, or a plant electrical motor controller. It would be next to impossible for a maintenance supervisor (or any other knowledgeable person) to describe in words the shape, size, configuration, relations of the various components of a machine, or its operation in sufficient detail for a wastewater maintenance operator to troubleshoot the process or machine properly. Blueprints are the universal language used to communicate quickly and accurately the information necessary to understand process operations or to disassemble, service, and reassemble process equipment.

The original drawing is seldom used in the plant or field, but copies, commonly called *blueprints*, are made and distributed to maintenance operators who need them. These blueprints are used extensively in water and wastewater operations to convey the ideas relating to the design, manufacture, and operation of equipment and installations. Simply, blueprints are reproductions or copies of original drawings. Blueprints are made by a special process that produces a white image on a blue background from drawings having dark lines on a light background. In addition to blueprints, *schematic diagrams* are also important pictorial representations with which the maintenance operator should be familiar. A schematic is a line drawing made for a technical purpose that uses symbols and connecting lines to show how a particular system operates.

Blueprints and schematics are particularly important to a maintenance operator because they provide detailed information (or views) for troubleshooting; that is, they help familiarize the troubleshooter with the overall characteristics of systems and equipment. In this chapter,

the focus is on blueprints and schematics representative of wastewater plant support equipment, systems, and processes. Major support equipment and systems discussed in this chapter include machine parts, machines, hydraulic and pneumatic systems, piping and plumbing systems, electrical systems, welding, and air conditioning and refrigeration (AC&R) systems.

3.1 BLUEPRINTS: THE UNIVERSAL LANGUAGE

Technical information about the shape and construction of a simple part, mechanism, or system may be conveyed from one person to another by the spoken or written word. As the addition of details makes the part, mechanism, or system more complex, the wastewater maintenance operator must have a precise method available that describes the object adequately. The methodology? Blueprints. Blueprints provide a universal language by which all information about a part, mechanism, or system is furnished to the operator and others.

Case Study 3.1. Groping in the Dark

One evening in December, an automatic bar screen at the Rachel's Creek Wastewater Treatment Plant jammed, and its motor overloaded. The overload tripped the electrical switchgear main circuit breaker, cutting off power to the entire building complex. The lack of electricity left the on-duty plant operator unable to perform her normal duties and left her literally groping in the dark.

The sudden, unexpected interruption of electrical power and simultaneous shutdown of the bar screen, the lighting and ventilation in the building, and other systems brought to a halt all things electrical but did not stop the flow of influent into the plant. The plant operator, well trained for such contingencies, immediately contacted the on-call maintenance operator and donned a self-contained breathing apparatus (SCBA) to protect herself against high sulfide levels, as the lack of ventilation immediately allowed off-gases (sulfides and methane) from raw influent to accumulate to dangerous levels in the bar screen room. Guided by the beam of a flashlight, the operator located the tripped circuit breaker. She reset the breaker, but electrical power was not restored. She correctly discerned that power to the entire switchgear was tripped.

Realizing that she would have to wait for the on-call maintenance operator to restore electrical power, she directed the flashlight beam along the floor leading to the manual bar screen. She raked debris from the screen until power was restored about 10 minutes later.

Note: The first treatment unit process for raw wastewater (influent) is coarse screening. The purpose of coarse screening is to remove large solids (e.g., rags, cans, rocks, branches, leaves, roots) from the flow before the flow moves on to downstream processes. A *bar screen* traps

debris as wastewater influent passes through. Typically, a bar screen consists of a series of parallel, evenly spaced long metal bars about 1 inch apart or a perforated screen placed in a channel. The screen may be coarse (2- to 4-inch openings) or fine (0.75- to 2.0-inch openings). The wastestream passes through the screen, and the large solids (screenings) are retained (trapped) on the bars for later removal. Bar screens may be manually cleaned (bars or screens are placed at an angle of 30° for easier solids removal with a hand rake) or mechanically cleaned (bars are placed at a 45° to 60° angle to improve automatic mechanical cleaner operation).

After arriving at the plant, the on-call maintenance operator had electrical power restored within 5 minutes. The troublesome bar screen was back in operation the next morning. This was good response and service from the maintenance operator. Obviously, maintenance operators who can provide such good service are valuable to plant operations. They advance up the promotional ladder quickly, and they usually make more money than the average plant operator. How did the maintenance operator at Rachel's Creek do such a professional job?

When the call came, the maintenance operator asked two questions: "How extensive is the power failure?" and "Do you know what caused it?" The operator said the whole building complex was down and that there was a loud grinding noise, then a louder popping sound from the bar screen when the trouble started.

When she first arrived at the plant site, the on-call maintenance operator, who had been cross-trained as an electrician, immediately went to the electrical substation to check for damage to the circuit breaker. After determining that the main circuit breaker appeared to be undamaged, she then went to check out the local switchgear for the building. The maintenance operator cut the individual power switches to all equipment before resetting the main circuit breaker at the substation. Then the maintenance operator put the lighting, ventilation, and other equipment online, one by one, avoiding resetting the bar screen breaker.

After restoring electrical power to lighting, ventilation, and other circuits, the maintenance operator checked out the bar screen and found that it was indeed jammed. The maintenance operator then examined the bar screen circuit breaker, which was built into the motor controller. This breaker should have tripped (opened), so the jammed bar screen would have been isolated and would be the only electrical device losing power. Something apparently had happened to this circuit breaker to make it malfunction.

The initial response to get the bar screen building complex (e.g., lighting, ventilation) back online again was good. Even though the maintenance operator was highly skilled and had considerable local knowledge (experience), she needed a lot of information to get this job done—and she needed it quickly. The information she needed came from blueprints:

- The maintenance operator located the substation on a plant layout.
- At the substation, the maintenance operator used an electrical utilities plan showing what equipment was installed there and how it should look.
- Later the following day, the maintenance team that made the actual bar screen repairs relied on drawings showing how to disassemble the bar screen drive mechanism. The drawing also showed the identification number of the part that failed (i.e., the bearings on the drive mechanism) so a replacement could be obtained from stock.

Blueprints are used almost everywhere in water and wastewater treatment systems. The bar screen malfunction just described points out that blueprints are among the most important forms of communication among people involved in plant maintenance operations.

3.1.1 Blueprint Standards

To provide a universal language, blueprints must communicate ideas to many different people. It logically follows that to facilitate this communication all industrialized nations need to develop technical drawings according to universally adopted standards. Moreover, such drawing standards must also include symbols, technical data, and principles of graphic representation.

Universal standardization practices allow blueprints to be uniformly interpreted throughout the globe. The standardization implication should be obvious: Parts, structures, machines, and all other products (designed according to the same system of measurement) may be actually manufactured and interchangeable.

Note: Universal standardization of blueprints and drawings is sometimes referred to as *drawing conventions*—that is, standard ways of drawing things so everyone understands the information being conveyed.

In this modern era, with its global economy, the interchangeability of manufactured parts is of increasing importance. Consider, for example, a machine manufactured in Europe that subsequently ends up being used in a factory in North America. Although such a machine is manufactured on one continent and is used on another, getting replacement repair parts normally is not a significant problem; however, if the user company has its own machine shop or access to one, it may decide, for one reason or another, that it wants to manufacture its own replacement parts. Without standardized blueprints, such an operation would be very difficult to accomplish.

3.1.1.1 Standards-Setting Organizations

Two standards-setting organizations have developed drafting standards that are accepted and widely used throughout the globe: the *American National Standards Institute* (ANSI) and the *International*

TABLE 3.1 BLUEPRINT SHEET SIZE

Standard U.S. Size (in.)	Nearest International Size (mm)
A, 8.5 × 11	A4, 210 × 297
B, 11 × 17	A3, 297 × 420
C, 17 × 22	A2, 420 × 594
D, 22 × 34	A1, 594 × 841
E, 34 × 44	AO, 841 × 1189

Source: ANSI, ANSI Y14.1: *Blueprint Sheet Size*, American National Standards Institute, New York, 1980.

Organization for Standardization (ISO; metric standards). Incorporated into these systems are other engineering standards generated and accepted by professional organizations dealing with specific branches of engineering, science, and technology. These organizations include the *American Society of Mechanical Engineers* (ASME), the *American Welders Society* (AWS), the *American Institute of Architects* (AIA), the U.S. military (MIL), and others. Moreover, to suit their own needs, some large corporations have adopted their own standards.

Note: All references to blueprints in this text closely follow the ANSI and ISO standards and current industrial practices.

3.1.1.2 ANSI Standards for Blueprint Sheets

The American National Standards Institute has established standards for the sheets onto which blueprints are printed (see Table 3.1).

3.1.2 Finding Information

The previous section pointed out the importance of using universal standards or drawing conventions with regard to correct interpretation of blueprints. In addition to knowing these conventions, we must also know where to look for information. In this section, we explain how to find the information needed in blueprints. Typically, designers use technical shorthand in their drawings; however, there generally is too much information to be included in a single drawing sheet. For this reason, several blueprints are often assembled to make a set of *working drawings*. Working drawings (drawings that furnish all the information required to construct an object) consist of two basic types: *detail drawings* for the parts produced and an *assembly drawing* for each unit or subunit to be put together.

3.1.2.1 Detail Drawings

A *detail drawing* is a working drawing that includes a great deal of data, such as the size and shape of the project, what kinds of materials should be used, how the finishing should be done, and what degree of accuracy is needed for a single part. Each detail must be given.

Note: Usually, a detail drawing contains only dimensions and information needed by the department for which it is made. The only part that may not have to be drawn is a *standard part*, one that can probably be purchased from an outside supplier more economically than it can be manufactured.

3.1.2.2 Assembly Drawings

Most machines and systems contain more than one part. Simply, *assembly drawings* show how these parts fit together. In addition to showing how the parts fit together, they provide an overall look of the construction and the dimensions required for installation. Assembly drawings also include a *parts list*, which identifies all the pieces comprising the item. A parts list is also called a *bill of material*.

Note: Because assembly drawings show the working relationship of the various parts of a machine or structure as they fit together, each part in the assembly is usually numbered and listed in a table on the drawing.

3.1.2.3 Title Block

The first place to look for information on a blueprint is the *title block*, an outlined rectangular space located in the lower right corner of the sheet. The title block is placed in the lower right corner because, when the print is correctly folded, it may be seen for easy reference and for filing. The purpose of the title block is to provide supplementary information on the part or assembly to be made and to include in one section of the print information that aids in identification and filing of the print.

Although title blocks used by different organizations can vary, certain information is basic. Figure 3.1 shows a blank blueprint sheet, with its title block and other features. The following list describes the information usually found in a title block; the letter in parentheses in each description refers to the example in Figure 3.1:

- *Title of drawing*—This box identifies the part or assembly illustrated (A).
- *Name of company and its location*—The space above the title is reserved for the name and location (complete address) of the designing or manufacturing firm (B).
- *Scale*—The drawing scale indicates the relationship between the size of the image and the size of the actual object (C). Some parts are shown at actual size, whereas others might be either too big or too small to show conveniently at full size; for example, we cannot show a large machine full size on an ordinary sheet of paper. The designer has the choice of drawing a machine, mechanical part, or other object larger or smaller than actual size. Typical scale notations are: 1/2" = 1" (one half actual size); FULL (actual size); 1:1 (actual size); 2:1 (twice size); 3, 4, 5, etc. (3, 4, 5, etc. times true

REVISIONS			
LTR	DESCRIPTION	DATE	APPROVED
			(L)
			(E)
			(K)
			(C)
			(D)
			(F)

DASH NO.	PART NO.	DESCRIPTION	MATERIAL	ITEM#
PARTS LIST				
TOLERANCE	APPROVALS	DATE		
(I)	DFTSMN		(B)	
	CHECKED	(G)		
	APPROVED		(A)	
FINISH	MATERIAL		SCALE	SIZE
(J)	(H)			DWG NO.
			DO NOT SCALE	SHEET OF
			DRAWING	

(M)
GENERAL NOTES UNLESS OTHERWISE SPECIFIED

Figure 3.1 Blank blueprint sheet.

size). When the scale is indicated to be “as noted,” it means that several scales have been used in making the drawing and each is indicated below the particular view to which it pertains.

Note: Measurements made on a blueprint should never be used because the print may have been reduced in size or stretched. Work only from the dimensions given on the print.

- **Drawing size**—Drawings are prepared on standard-size sheets in multiples of 8.5×11 and 9×12 inches and are designated by a letter to indicate size (D).
- **Drawing number**—The drawing number is used to identify and control the blueprint (E). It is also used to designate the part or assembly shown on the blueprint (i.e., it becomes the number of the part itself). The number is usually coded (to the particular industry, not universally applicable to all industries) to indicate department, model, group, serial number, and dash numbers. This number is also used to file the drawings, making it easier to locate them later on.

Note: A *dash number* is a number preceded by a dash after the drawing number; it indicates right- or left-hand parts as well as neutral parts or detail and assembly drawings.

- **Sheet number**—Sheet numbering on multiple-sheet blueprints indicates the consecutive order and total number of prints, and which one of the series this particular drawing happens to be (F).
- **Approvals block**—This block is for the signatures and date of release by those who have responsibility for making or approving all or certain facets of the drawing or the manufacture of the part (G). The block may include signature and date blocks for the following:

- Draftsperson
- Checked (for the engineer who checked the drawing for completeness, accuracy, and clarity)
- Design (for the person responsible for the design of the part)
- Stress (for the engineer who ran the stress calculations for the part)
- Materials (for the person whose responsibility it is to see that the materials required to make the part are available)
- Production (for the engineer who approved the producibility of the part approves the drawing)
- Supervisor (for the person in charge of drafting, who indicates approval by signing and dating this block)
- Approved (any other required approvals; each person signs the document and fills in the date on the appropriate line when his or her portion of the work is finished or approved)
- *Materials block*—This block specifies exactly what the part is made of (e.g., the type of steel to be used) and often includes the size of raw stock to be used (H).
- *Tolerance block*—This block indicates the general tolerance limits for one-, two-, and three-place decimal and angular dimensions (I). The tolerance limits are often necessary because nothing can be made to the exact size specified on a drawing. Normal machining and manufacturing processes allow for slight deviations. These limits are applicable unless the tolerance is given along with the dimension callout.

Note: *Tolerance* is defined as the total amount of variation permitted from the design size of a part. Parts may have a tolerance given in fractions or decimal inches or decimal millimeters.

- *Finish block*—This block gives information on how the part is to be finished (buffed, painted, plated, anodized, or other). Specific finish requirements would be a callout on the drawing with the word “NOTED” in the finish block (J).
- *Parts list (bill of materials)*—A parts list is a tabular form usually appearing right above the title block on the blueprint (K); it is used only on assembly and installation drawings. The purpose of the parts list is to provide specific information on the quantity and types of materials used in the manufacturing and assembling of parts of a machine or structure. The parts list allows a purchasing department to requisition the quantity of materials required to produce a given number of the assemblies. Individual component parts, their part numbers, and the quantity required for each unit are listed here.

Note: The parts list is built from the bottom up. The columns are labeled at the bottom (just above the words “Parts List”), and parts are listed in reverse numerical order above these categories. This allows the list to

NOTICE OF CHANGE						
LTR	ZONE	DESCRIPTION	SERIAL	DATE	DR	APP
(A)	(B)	(C)	(D)	(E)	(F)	(G)

Figure 3.2 Revision/change block.

grow into the blank space as additional parts are added. If a drawing is complicated, containing many parts, the parts list may be on a separate piece of paper that is attached to the drawing.

- **Revision (change block)**—On occasion, after a blueprint has been released, it is necessary to make design revisions or changes. The revision or change block is a separate block positioned in the upper right-hand corner of the drawing (L). It is used to note any changes that have been made to the drawing after its final approval. It is placed in a prominent position, because we need to know which revision we are using and what features have been revised or changed. We also need to know whether the changes have been approved; the initials of the draftsman making the change and those approving it are required. When a drawing revision or change notice has been prepared, the drawing is revised and the pertinent information recorded in the revision/change block. The following items are usually included in the revision/change block:
 - **Sequence Letter (LTR)**—The sequence letter is assigned to the revision/change and recorded in the revision/change block (Figure 3.2A). This index letter is also referenced to the field of the drawing next to the changed effected (e.g., “A1. BREAK ALL SHARP EDGES”).
 - **Zone**—Used on larger sized prints, this column aids in locating changes (Figure 3.2B).
 - **Description**—This column provides a concise description of the change; for example, when a note is removed from the drawing, the type of note is referred to in the description block (e.g., “PLATING NOTE REMOVED”), or a note is added when a dimension is changed (e.g., “WAS .975–1.002”) (Figure 3.2C).
 - **Serial**—This column lists the serial number of the assembly or machine on which the change becomes effective (Figure 3.2D).
 - **Date**—Entries in the date column indicate the dates changes were written (Figure 3.2E).
 - **Drafter (DR)**—This column is initialed by drafters making the changes (Figure 3.2F).

- *Approved (APP)*—This column carries the initials or name of the engineer approving the change (Figure 3.2G).

A few industries will include other items in their revision/change block to further document the changes made in the original blueprint. Some of these include:

- *Checked*—This column is for the initials or signature of the person who has checked and approved the revision or change.
- *Authority*—This column records the approved engineering change request numbers.
- *Change number*—The change number column lists drawing change notice (DCN) numbers.
- *Disposition*—This column carries coded numbers indicating the disposition of change requests.
- *Microfilm*—This column is used to indicate the date a revised drawing was placed on microfilm.
- *Effective on*—This column (sometimes a separate block) gives the serial number or ship number of the machine, assembly, or part on which the change becomes effective. The change may also be noted as becoming effective on a certain date.

Note: A drawing that has been extensively revised or changed may be redrawn and carry an entry to that effect in the revised/change block, or the drawing number may carry a dash letter (-A) indicating a revised or changed drawing.

Considerable variation exists among industries in the form of processing and recording changes in prints (see Figure 3.3). The information presented in this section will allow maintenance operators to develop an understanding of the change system in general.

3.1.2.4 Drawing Notes

Notes on drawings provide information and instructions that supplement the graphic presentation as well as the information in the title block and list of materials. Notes on drawings convey many kinds of information (e.g., the size of holes to be drilled, type fasteners to be used, removal of machining burrs). Specific notes like these are tied by *leaders* directly to specific features.

REVISIONS				
ZONE	LTR	DESCRIPTION	DATE	APPROVED
E-3	B	INCORP FEI I REVISED MARKING B18 WAS A4 N/A WAS 12303		

Figure 3.3 Change block with drawing change notice (DCN) recorded.

1. Break sharp edges .030 r unless otherwise specified.
2. This part shall be purchased only from sources approved by the treatment department.
3. Finish all over.
4. Remove burrs.
5. Metallurgical inspection required before machining.

Figure 3.4 Examples of general notes on drawings.

3.1.2.4.1 General Notes

General notes refer to the entire drawing. They are located at the bottom of the drawing, to the left of the title block. General notes are not referenced in the list of materials nor from specific areas of the drawing. Some examples of general notes are given in Figure 3.4.

Note: When there are exceptions to general notes on the field of the drawing, the general note will usually be followed by the phrase “EXCEPT AS SHOWN” or “UNLESS OTHERWISE SPECIFIED.” These exceptions will be shown by local notes or data on the field of the drawing.

3.1.2.4.2 Local Notes

Specific or local notes apply only to certain features or areas and are located near, and directed to, the feature or area by a leader (see Figure 3.5). Local notes may also be referenced from the field of the drawing or the list of materials by the note number enclosed in a *flag* (equilateral triangle; see Figure 3.6). Some examples of local notes are given in Figure 3.7.

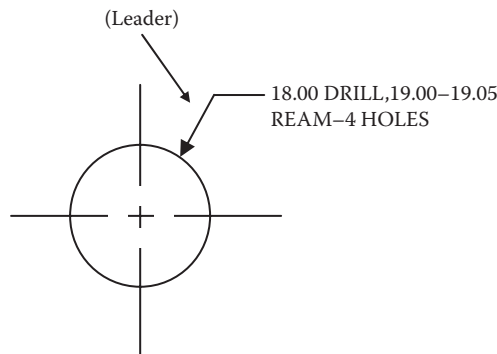

Figure 3.5 Local note directed to feature.



Figure 3.6 Local note reference.

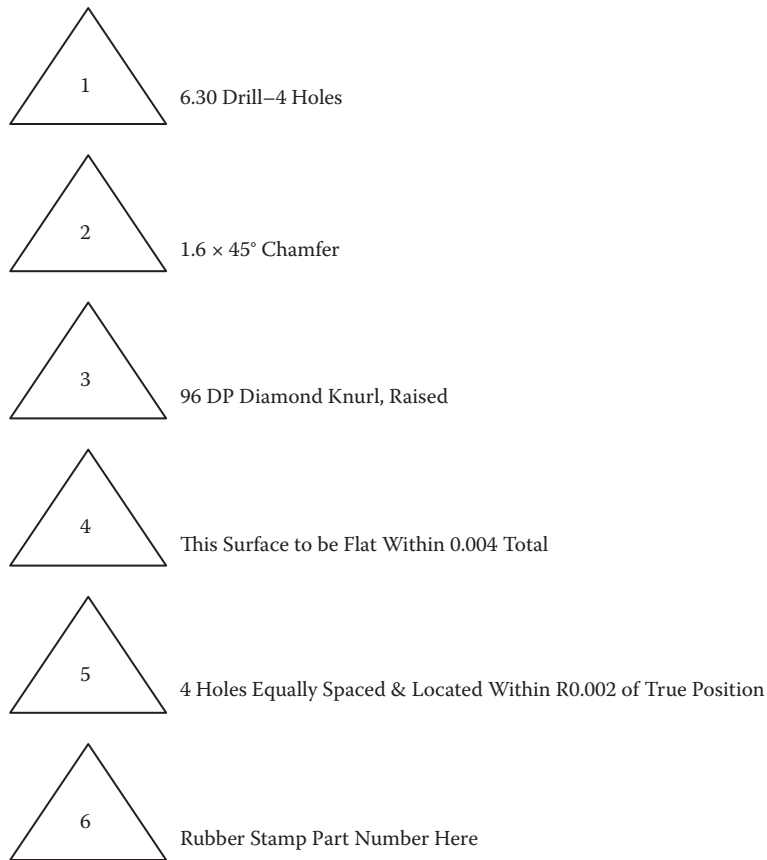

Figure 3.7 Examples of local notes on drawings.

Case Study 3.2. The Maintenance Operator's "Toolbox"

When we place a service call for a heating, air conditioning, television, washing machine or dryer, or other household appliance or system malfunction, usually the repair person responds in short order. The usual practice is for the repair person to check out or look over the appliance or system to get a feel for what the problem is. After determining that the problem is more than just turning the “on” switch to the correct position and that the system is properly aligned for operation (e.g., valves opened or closed as per design), the repair person will usually open his or her toolbox and begin troubleshooting to identify the problem. After zeroing in on the cause of the malfunction, the repair person makes the necessary repair or adjustment and then tests the unit to ensure proper operation.

There is nothing unusual about the scenario just described; it is nothing more than a routine practice that most of us are familiar with—unfortunately, some of us much more than others. In fact, this practice is so common and familiar that we do not give it much thought. We are trying to make an important point here, though. Let’s take another look at the routine service call procedure described above:

- We have a problem with a home appliance or system
- We place a service call
- A repair person responds
- The repair person checks out the appliance or system
- The repair person corrects the problem immediately, or ...
- The repair person determines that the malfunction is a bit more complex
- The repair person opens his or her toolbox and the troubleshooting process begins
- Eventually, the fault is found and corrected (we hope).

The repair person opens his or her toolbox. This is the part of the routine repair procedure we want to focus on. Why? Good question.

The best way to answer this question is to provide an illustration. Whenever I have hired a repair person to repair a home appliance, a carpenter to repair a wooden deck, a plumber to unclog our pipes, or an electrician to install a new lighting fixture, these skilled technicians always responded with toolbox in hand. Have you noticed this, too?

We once hired a carpenter to replace several windows with new ones. During this replacement process, we noticed that the carpenter lugged a huge, heavy, clumsy toolbox from window to window. We also noticed that he was able to remove the old windows and install the new ones using only a few basic handtools—screwdrivers, chisel, and hammer. Why, then, the big, clumsy toolbox? Eventually, we got around to asking him that very question: “Why the big toolbox?” After looking at us like we were somewhat out to lunch, he replied as follows: “I lug this big toolbox around with me everywhere I go because I never know for sure what tool I will need to do the job at hand. It is easier to have my complete set of tools in easy reach so I can get the job done without running all over the place to get this or that tool. The way I see it, it just makes good common sense.”

“I lug this big toolbox around with me everywhere I go because I never know for sure what tool I will need to do the job at hand” not only makes good common sense but also is highly practicable. For those of us who have worked in water or wastewater treatment plant maintenance operations, we have seen this same routine practiced over and over again by the plant maintenance operator who responds to a plant trouble call: “It just makes good common sense.”

At this point the reader might be thinking, “So, beyond the obvious, what is the author’s point?” Another good question. Simply put, maintenance operators must have an extensive assortment of tools in their toolboxes to perform many of the plant maintenance actions they are required to. “It just makes good common sense.”

But, there is more to consider. We can choose from many types of toolboxes and a large variety of tools. If we fill a standard-sized portable toolbox with tools (the best tools that money can buy), they do us little good unless we know how to use them properly. Tools are designed to assist us in performing certain tasks. Like electricity, the internal combustion engine, and the computer, tools, when properly used, are extremely helpful to us. They not only make tasks easier but also save much time. On the other hand, few would argue against the adage that any tool is only as good as the person's ability or skill in using it properly.

Ability and skill are also important tools. They are important tools in the sense that any water or wastewater maintenance operator without a certain amount of ability or skill is, no matter the sophistication of the tool in hand, just another unskilled user of the tool. If we agree that ability and skill are tools, we must also agree that they are tools kept in a different kind of toolbox. The toolbox we are referring to is obvious, of course. Moreover, this kind of toolbox is one we do not have to worry about forgetting to bring to any job we are assigned to perform; we automatically carry it with us everywhere we go. Ability and skill are not normally innate qualities; instead, they are characteristics that have to be learned. They are also general terms; their connotations are wide and various.

Simply, ability and skill entail more than just knowing how to properly use a handsaw or other portable tool; for example, with a little practice, just about anyone can use a handsaw to cut a piece of lumber. But, what if we need to cut the lumber to a particular size or dimension? Obviously, to make such a cut to proper size or specification, we not only need to know how to use the cutting tool but also how to measure the stock properly. Moreover, to measure and determine the proper size of the cut to be made, we also need to know how to use basic math operations to determine how much needs to be actually cut. "It just makes good common sense."

This chapter provides a brief review of the basic math we need and find most useful in reading blueprints. We are likely to find that we already know most of it. Some of it may be new, but only because we have not worked with blueprints before.

Although blueprints ordinarily give us sizes, we occasionally have to do some calculating to get the exact dimension of what we are particularly concerned with. Usually, we find it by adding and subtracting. At other times, we may have to calculate the number of pieces of a given length we can get from a particular piece of wood, pipe, or bar of steel or aluminum or other material. That is usually a matter of multiplying and dividing. We may also want to know how many square feet there are in a particular room, doorway, or roof area. In addition to the basic math operations of adding, subtracting, multiplying, and dividing, the maintenance operator must also know how to work with fractions and decimals. A basic understanding of angles, areas of rectangles, and the radius of a circle is also important.

3.2 UNITS OF MEASUREMENT

A basic knowledge of units of measurement and how to use them is essential. Wastewater maintenance operators should be familiar both with the U.S. Customary System (USCS) or English System and the International System of Units (SI). Table 3.2 gives conversion factors between the SI and USCS systems for three of the basic units that are encountered in blueprint reading. The basic units used in blueprint reading are for straight-line (linear) measurements; that is, most of the calculating we do is with numbers of yards, feet, and inches, or parts of them. What we actually do is find the distance between two or more points and then use numbers to express the answer in terms of yards, feet, and inches (or parts of them). 12 inches make 1 foot (ft), 3 feet make 1 yard (yd). The symbol indicating an inch is " "; the symbol for a ft is ' .

As technology has improved, so has the need for closer measurement. As we develop new improved measuring tools, it becomes possible to make parts to greater accuracy. Moreover, now that we are in the age of interchangeable parts, we have developed standards of various kinds. This, in turn, allows us to know what is needed and meant by a given specification. Various thread specifications are a good example, as are the conventions and symbols used on blueprints themselves.

Wastewater operations familiar to us today would not be possible without our ability to make close measurements and to do so accurately. This is why basic math operations are used and why it is important to be familiar with them. The basic unit of linear measurement in the United States is the yard, which we break down into feet and inches, and parts of them. In our maintenance work, we are concerned with all of them. We may work more with yards and feet when using plant building drawings. At other times, when we work with plant or pumping station machinery, we find them represented in inches, or parts of inches.

3.2.1 Fractions and Decimal Fractions

The number 8 divided by 4 gives an exact quotient of 2, which may be written as $8/4 = 2$; however if we attempt to divide 5 by 6 we are unable to calculate an exact quotient. This division may be written as $5/6$ (read "five sixths"). This is called a *fraction*. The fraction $5/6$ represents a number, but it is not a whole number. For this reason, our idea of numbers must be enlarged to include fractions.

**TABLE 3.2 COMMONLY USED
UNITS AND CONVERSIONS**

Quantity	SI Units	SI Symbol	× Conversion Factor	USCS Units
Length	Meter	m	3.2808	ft
Area	Square meter	m ²	10.7639	ft ²
Volume	Cubic meter	m ³	35.3147	ft ³

In blueprint reading, we are specifically concerned with fractions of some unit involved with measurements; for example, a half inch is one of two parts that make up an inch. This could be written down as $1/2$ inch, where the right-hand number (2, the denominator) indicates that it takes two parts to make up the whole unit, and the left-hand number (1, the numerator) indicates that we have one of the two parts needed. One quarter of an inch, which would be shown on a blueprint as $1/4$ ", means that we need four parts to make up an inch. Because one is all we need, one is all that is shown. We could just as easily have $3/4$, $5/8$, or $11/16$. The basic meaning of the numbers would still be that we need three quarters of an inch, or five eighths of an inch, or eleven sixteenths of an inch. In maintenance practice, the inch is further broken down into thirty-seconds (32nds) and sixty-fourths (64ths).

Note: A 64th is the smallest fraction we will use; it is the smallest fraction shown on a machinist's ruler, sometimes incorrectly referred to as a *scale*.

A *decimal fraction* is a fraction that may be written with 10, 100, 1000, 10,000, or some other multiple of 10 as its denominator; thus, $47/100$, $4256/10,000$, $77/1000$, and $3437/1000$, for example, are decimal fractions. When writing a decimal fraction, it is standard procedure to omit the denominator and instead merely indicate what that denominator is by placing a *decimal point* in the numerator so there are as many figures to the right of this point as there are zeros in the denominator. Thus, $47/100$ is written as 0.47; also, $4256/10,000 = 0.4256$, $77/1000 = 0.077$, and $3437/1000 = 3.437$.

Note: The word "decimal" comes from the Latin word for tenth or tenth part.

Note: Called *decimal fractions* because they are small parts of a whole unit, these fractions are useful in shortening calculations. Most technologies now use the decimal fractions as a matter of course.

Table 3.3 lists all the fractions we are likely to see on our plant machine prints. The figures at the right hand side of each column mean exactly the same thing, except that the numbers are expressed as decimal parts of an inch.

With the passage of time and corresponding improvements in technology, greater accuracy became possible (measurements in fractions of an inch were no longer exact enough). Smaller parts of an inch were needed, and they were provided by dividing the inch into 1000 parts, the parts being referred to as "thousandths of an inch." One-thousandth of an inch is written as ".001". Common measurements of an inch, for example, can be expressed as follows:

One inch	1.000"
One-thousandth of an inch	.001"
One-ten-thousandth	.0001"
One-millionth	.000001"

**TABLE 3.3 COMMON FRACTIONS
AND THEIR DECIMAL EQUIVALENTS**

Fractions	Decimals	Fractions	Decimals
1/64	.015625	33/64	.515625
1/32	.03125	17/32	.53215
3/64	.046875	35/64	.546875
1/16	.0625	9/16	.5625
5/64	.078125	37/64	.578125
3/32	.09375	19/32	.59375
7/64	.109375	39/64	.609375
1/8	.125	5/8	.625
9/64	.140625	41/64	.640625
5/32	.15625	21/32	.65625
11/64	.171875	43/64	.671875
3/16	.1875	11/16	.6875
13/64	.203125	45/64	.703125
7/32	.21875	23/32	.71875
15/64	.234375	47/64	.734375
1/4	.25	3/4	.75
17/64	.265625	49/64	.765625
9/32	.28125	25/32	.78125
19/64	.296875	51/64	.796875
5/16	.3125	13/16	.8125
21/64	.328125	53/64	.828125
11/32	.34375	27/32	.84375
23/64	.359375	55/64	.859375
3/8	.375	7/8	.875
25/64	.390625	57/64	.890625
13/32	.40625	29/32	.90625
27/64	.421875	59/64	.921875
7/16	.4375	15/16	.9375
29/64	.453125	61/64	.953125
15/32	.46875	31/32	.96875
31/64	.484375	63/64	.984375
1/2	.5	1/1	1.0

3.3 ALPHABET OF LINES

Case Study 3.3. Just Lines

Over the years we have heard seasoned maintenance operators claim that no blueprint or technical diagram exists that they could not use or understand. At one time, we might have considered this to be more brag-gadocio than truth, and we might have continued to think this way if we hadn't finally cornered one of these seasoned maintenance types and asked: "What makes you so confident that you can read and understand any technical blueprint or drawing?" At first, somewhat peeved that we would ask such an obviously dumb question, this maintenance operator answered in a condescending tone of voice: "I know that I can read and understand any print or drawing because prints and drawings are

nothing more than a bunch of drawn lines. Even the components that the lines are hooked to are nothing more than lines shown in a different fashion. It all comes down to a bunch of lines, nothing more.”

3.3.1 Just a Bunch of Drawn Lines?

Notwithstanding the summation provided by this seasoned maintenance operator, for the engineer, the designer, and the drafter, engineering-type drawings are more than “a bunch of drawn lines.” No doubt lines are important; few would argue with this point. Moreover, to correctly interpret the blueprint when servicing a part or assembly, the maintenance operator and technician must recognize and understand the meaning of ten kinds of lines that are commonly used in engineering and technical drawings. These lines, known as the *alphabet of lines* (a list of line symbols), are used universally throughout industry. Each line has a definite form, shape, and width (thick, medium, or thin), and when they are combined in a drawing they convey information essential to understanding the blueprint (e.g., shape and size of an object).

Note: Each line on a technical drawing has a definite meaning and is drawn in a certain way. We use the line conventions, together with illustrations showing various applications, recommended by the American National Standards Institute (ANSI, 1973a) throughout this text.

With regard to the seasoned maintenance operator stating that technical drawings are “nothing more than a bunch of drawn lines,” we agree, to a point, but feel it would be more accurate to say that the *line* is the basis of all technical drawings. The point is that, by combining lines of different thicknesses, types, and lengths, just about anything can be described graphically and in sufficient detail so persons with a basic understanding of blueprint reading can accurately visualize the shape of the component. To understand a blueprint, then, we must know and understand the alphabet of lines. The following sections explain and describe each of these lines.

3.3.2 Visible Lines

The visible line (or *object line*) is a thick (dark), continuous line that represents all edges and surfaces of an object that are visible in view. A visible line (see Figure 3.8) is always drawn thick (dark) and solid so the outline or shape of the object is clearly emphasized on the drawing.

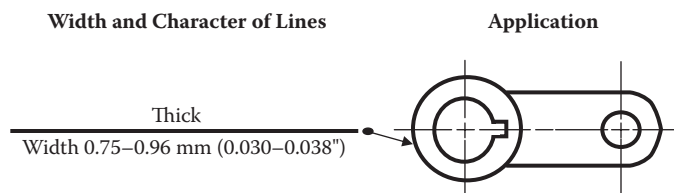

Figure 3.8 Visible line. (Adapted from Brown, W.C., *Blueprint Reading for Industry*, The Goodheart–Wilcox Company, South Holland, IL, 1989, pp. 14–18.).

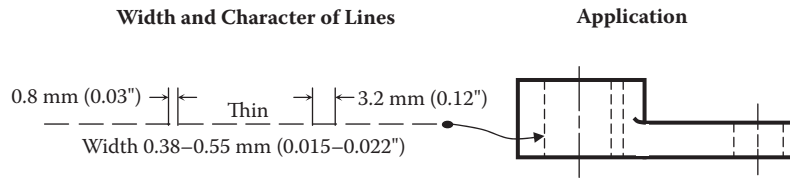

Figure 3.9 Hidden line. (Adapted from Brown, W.C., *Blueprint Reading for Industry*, The Goodheart–Wilcox Company, South Holland, IL, 1989, pp. 14–18.)

Note: The visible line represents the outline of an object. The thickness of the line may vary according to the size and complexity of the part being described (Olivo and Olivo, 1999).

3.3.3 Hidden Lines

Hidden lines are thin, dark, medium-weight, short dashes used to show edges, surfaces, and corners that are not visible in a particular view (see Figure 3.9). Many of these lines are invisible to the observer because they are covered by other portions of the object. They are used when their presence helps to clarify a drawing and are sometimes omitted when the drawing seems to be clearer without them.

3.3.4 Section Lines

Usually drawn at an angle of 45°, section lines are thin lines used to indicate the cut surface of an object in a sectional view. In Figure 3.10A, the section lining is composed of cast iron. This particular section lining is commonly used for other materials in the section except where the draftsman indicates a specific material for a section. Figure 3.10B, for example, shows symbols for other specific materials.

3.3.5 Center Lines

Center lines are thin (light), broken lines consisting of alternating long and short dashes and are used to designate the centers of part of or a whole circle, hole, arc, and symmetrical object (see Figure 3.11). The symbol *L* is often used with a center line. On some drawings, only one side of a part is drawn, and the letters *SYM* are added to indicate that the other side is identical in dimension and shape. Center lines are also used to indicate paths of motion.

3.3.6 Dimension and Extension Lines

Dimension lines are thin, dark, solid lines broken at the dimension and terminated by arrowheads, which indicate the direction and extent of a dimension (see Figure 3.12). Fractional, decimal, and metric dimensions are used on drawings to give size dimensions. On machine

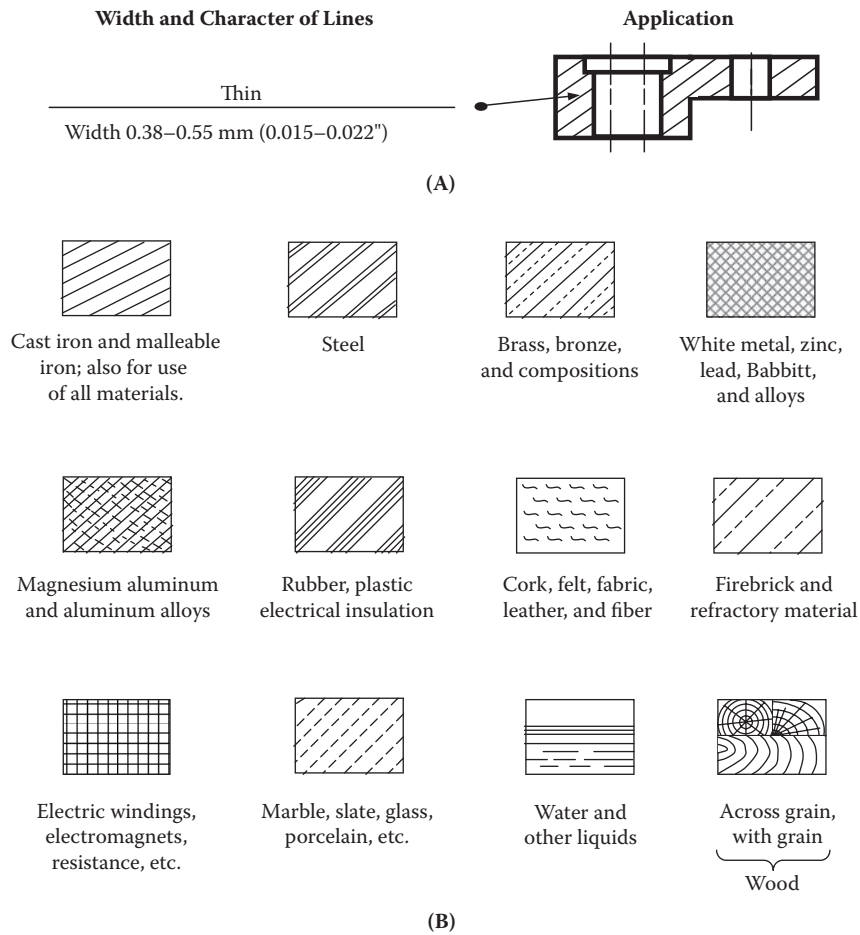

Figure 3.10 Section lines. (Adapted from Brown, W.C., *Blueprint Reading for Industry*, The Goodheart-Wilcox Company, South Holland, IL, 1989, pp. 14–18, 82.)

drawings, the dimension line is broken, usually near the middle, to provide an open space for the dimension figure.

Note: The tips of arrowheads used on dimension lines indicate the exact distance referred to by a dimension placed at a break in the line. The tip of the arrowhead touches the extension line. The size of the arrow is determined by the thickness of the dimension line and the size of the drawing.

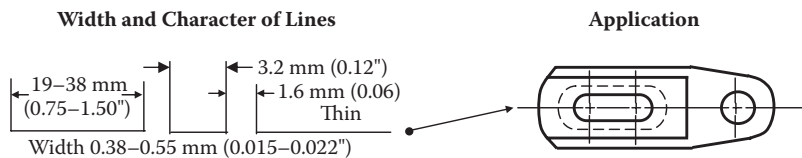

Figure 3.11 Center line. (Adapted from Brown, W.C., *Blueprint Reading for Industry*, The Goodheart-Wilcox Company, South Holland, IL, 1989, p. 83.)

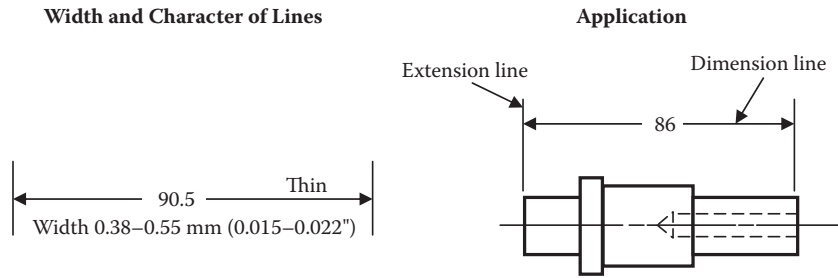

Figure 3.12 Dimension line, extension line and leaders. (Adapted from Brown, W.C., *Blueprint Reading for Industry*, The Goodheart-Wilcox Company, South Holland, IL, 1989, p. 84.)

Extension lines are thin, dark, solid lines that extend from a point on the drawing to which a dimension refers. Simply, extension lines are used in dimensioning to show the size of an object (see Figure 3.12).

Note: A space of 1/16 inch is usually allowed between the object and the beginning of the extension line.

3.3.7 Leaders

Leaders are thin inclined solid lines leading from a note or a dimension (see Figure 3.12) that terminate in an arrowhead or a dot touching the part to which attention is directed.

3.3.8 Cutting Plane or Viewing Plane Lines

To obtain a sectional view, an imaginary cutting plane is passed through the object as shown in Figure 3.13. This cutting plane line or viewing plane line is either a thick (heavy) line with one long and two short dashes or a series of thick (heavy), equally spaced long dashes.

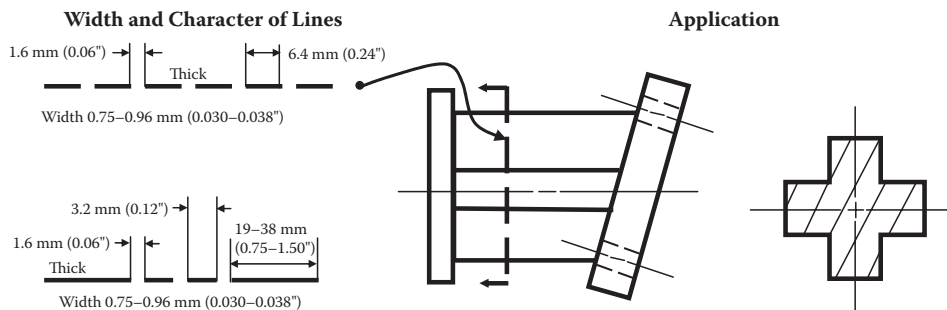

Figure 3.13 Cutting plane or viewing plane lines. (Adapted from Brown, W.C., *Blueprint Reading for Industry*, The Goodheart-Wilcox Company, South Holland, IL, 1989, p. 85.)

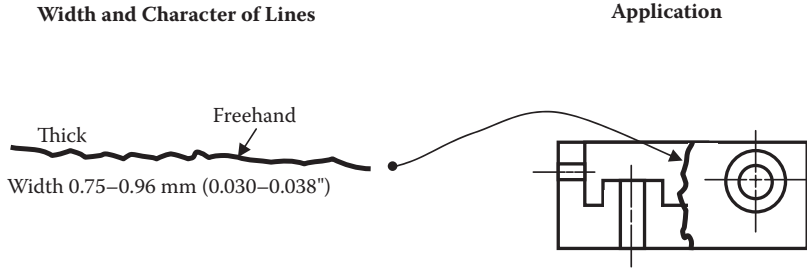

Figure 3.14 Short-break line. (Adapted from Brown, W.C., *Blueprint Reading for Industry*, The Goodheart-Wilcox Company, South Holland, IL, 1989, pp. 14-18.)

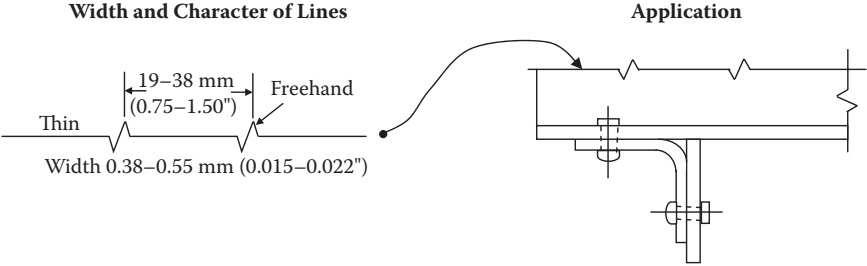

Figure 3.15 Long-break line. (Adapted from Brown, W.C., *Blueprint Reading for Industry*, The Goodheart-Wilcox Company, South Holland, IL, 1989, p. 80.)

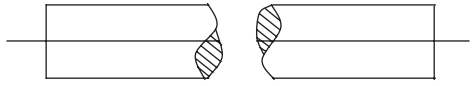

Figure 3.16 Cylindrical S-break.

3.3.9 Break Lines

To break out sections for clarity (e.g., from behind a hidden surface) or to shorten parts of objects that are constant in detail and would be too long to place on a blueprint, break lines are used. Typically, three types of break lines are used. When the part to be broken requires a short line, the thick, wavy *short-break line* is used (see Figure 3.14). If the part to be broken is longer, the thin *long-break line* is used (see Figure 3.15). In round stock, such as shafts or pipe, the thick *S break* is used (see Figure 3.16).

3.3.10 Phantom Lines

Limited almost entirely to detail drawings, phantom lines are thin lines composed of alternating long dashes and pairs of short dashes. They are used primarily to indicate: (1) alternative positions of moving parts (see Figure 3.17, right end), (2) adjacent positions of related parts such as an existing column (see Figure 3.18), and (3) objects having a series of identical features (repeated detail), as in screwed shafts and long springs (see Figure 3.19).

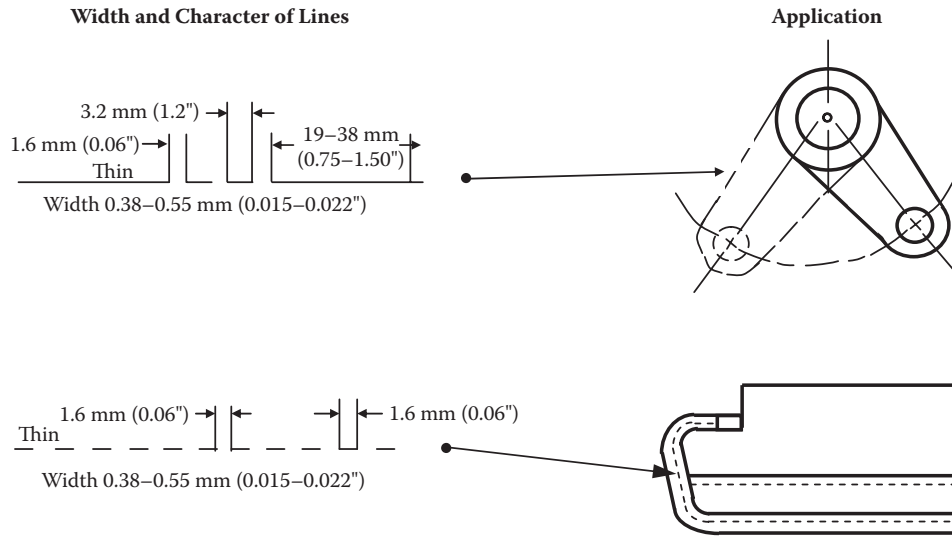

Figure 3.17 Phantom lines. (Adapted from Brown, W.C., *Blueprint Reading for Industry*, The Goodheart-Wilcox Company, South Holland, IL, 1989, p. 79.)

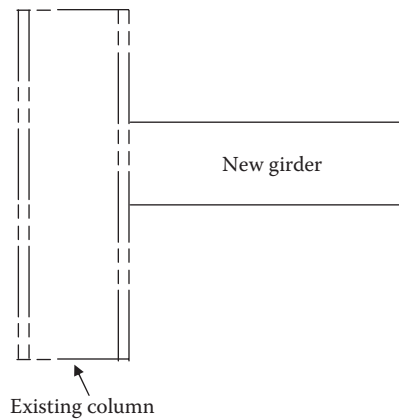

Figure 3.18 Phantom lines.

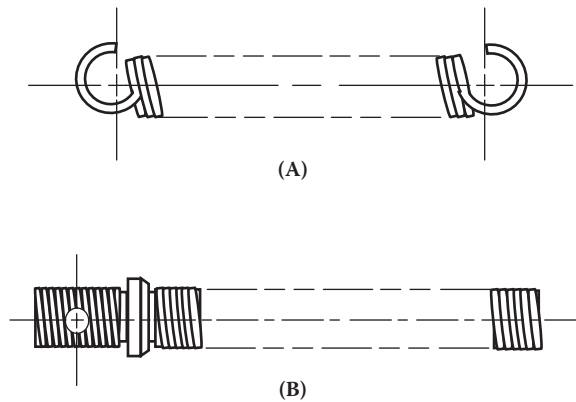

Figure 3.19 Phantom lines: (A) spring; (B) screw shaft.

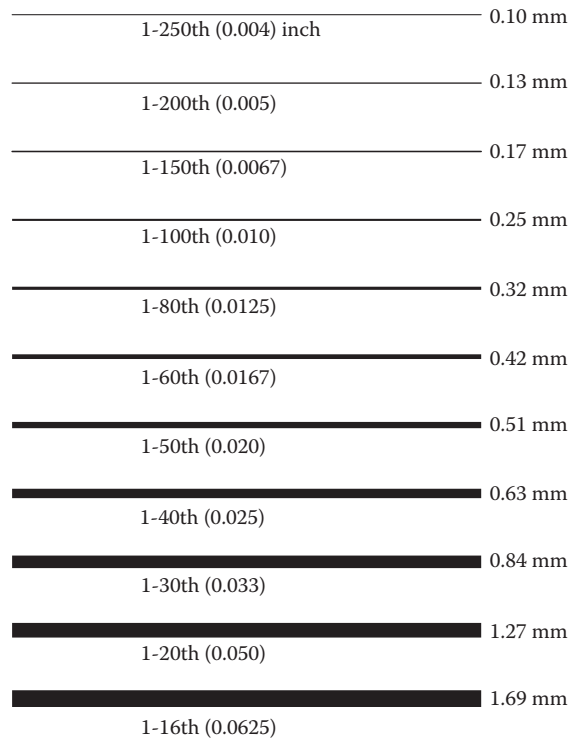

Figure 3.20 Line gauge.

3.3.11 Line Gauge

The line gauge, used by draftspersons and shown in Figure 3.20, is convenient when referring to lines of various widths.

3.3.12 Views

In the context of reading blueprints, when we speak of various views, they speak for themselves.

3.3.12.1 Orthographic Projections

When a draftsperson sets pencil to paper to draw a particular object such as a machine part, a basic problem is faced because such objects are three dimensional; that is, they have height, width, and depth. No matter the skill of the draftsperson, an object can only be drawn in two dimensions on a flat two-dimensional (2D) sheet of paper (height and width). A draftsperson typically works with three-dimensional (3D) objects, but how can these 3D objects be represented on a sheet of paper? One way to do this is with a *three-dimensional pictorial*. A 3D pictorial is a drawing that displays three sides of an object. A pictorial view of a 3D object is shown in Figure 3.21. In a pictorial view, the object is seen in such a way that three of the six sides of the object are visible. In this case, the *top*, *front*, and *right* sides of the object are visible. The other sides, the *bottom*, *rear*, and *left*, are not visible in this view. In addition

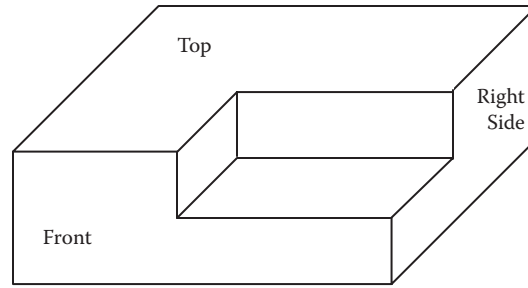

Figure 3.21 Pictorial view of a 3D object.

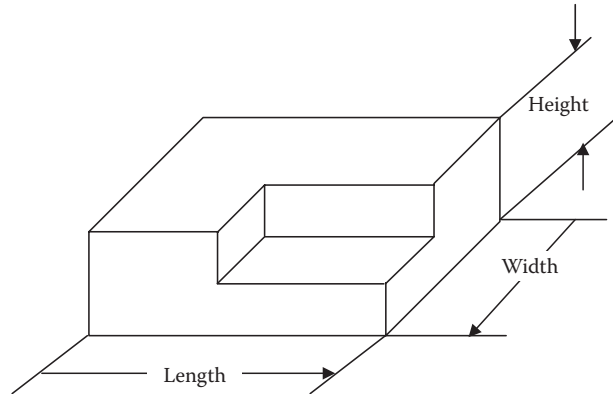

Figure 3.22 Dimension of an object.

to addressing the sides of a 3D object, we must also refer to the three dimensions of an object: *length*, *width*, and *height*. The dimensions of an object are shown in Figure 3.22.

To get around the basic problem of drawing 3D objects in such a manner as to make them usable in industry, *orthographic views* are used. It is often useful to choose the position from which an object is seen, or the *viewpoint*, so only one side (two dimensions) of the object is visible. This is an orthographic view of an object. A *top* (or *plan*) view shows the top side of the object, with the length and width displayed. A *front view* (or *front elevation*) shows the front side of the object, with the length and height displayed. A *right-side view* (or *right elevation*) shows the right side of the object, with the width and height displayed.

Note: The object is usually drawn so its most important feature appears in the front view.

To create an orthographic view, imagine that the object shown in Figure 3.22 is inside a glass box (see Figure 3.23). The edges of the object are projected onto the glass sides. Next, imagine that the sides of the glass box are hinged so when it is opened the views are as shown in Figure 3.24. These are the orthographic projections of the 3D object.

Note: Notice that the views shown in Figures 3.24 are arranged so the top and front projections are in vertical alignment, while the front and side views are in horizontal alignment (shown in Figure 3.25).

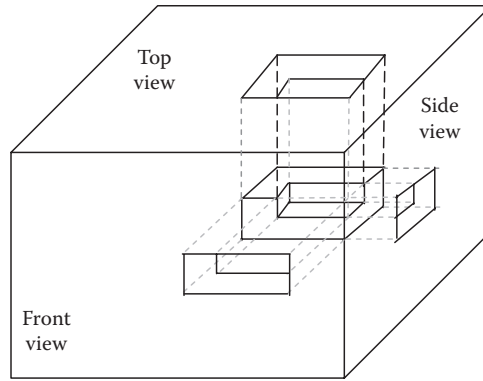

Figure 3.23 3D object inside a glass box.

3.3.12.2 One-View Drawings

Frequently, a one-view drawing supplemented by a note or lettered symbols is sufficient to describe clearly the shape of a relatively simple object (i.e., *simple* meaning parts that are uniform in shape); for example, cylindrical objects (shafts, bolts, screws, and similar parts) require only one view to describe them adequately. According to ANSI standards,

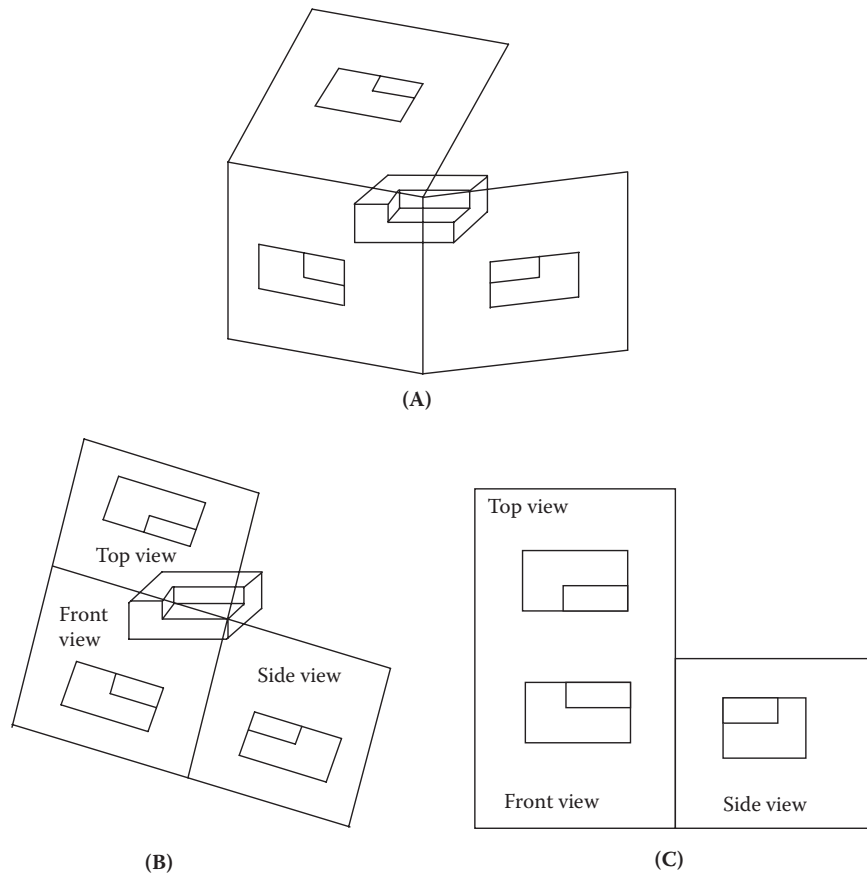

Figure 3.24 Various orthographic projection of the 3D object.

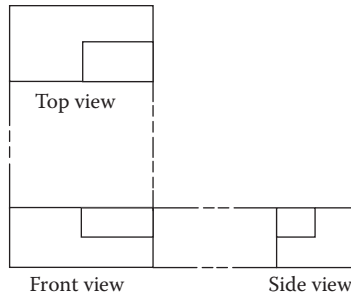

Figure 3.25 Proper alignment of orthographic projections.

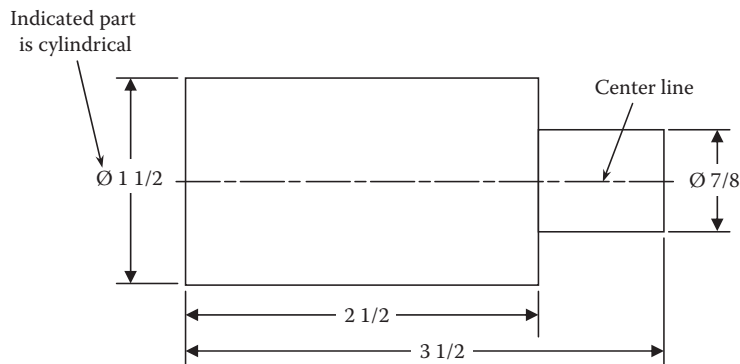

Figure 3.26 One-view drawing of cylindrical shaft; \emptyset or DIA indicates that the part is cylindrical. Center line shows that the part is symmetrical.

when a one-view drawing of a cylindrical part is used (see Figure 3.26), the dimension for the diameter must be preceded by the symbol \emptyset . In many cases, the older, but widely used, practice for dimensioning diameters is to place the letters *DIA* after the dimension. The main advantage of one-view drawings is the saving in drafting time; moreover, such a drawing simplifies blueprint reading.

Note: In both applications, the symbol \emptyset or the letters *DIA* and the use of a center line indicate that the part is cylindrical.

The one-view drawing is also used extensively for flat parts. With the addition of notes to supplement the dimensions on the view, the one view furnishes all of the information necessary for accurately describing the part (see Figure 3.27). (Note that in Figure 3.27 a note indicates the thickness as $3/8$ ".)

3.3.12.3 Two-View Drawings

Often only two views are required to describe clearly the shape of simple, symmetrical flat objects and cylindrical parts; for example, sleeves, shafts, rods, and studs only require two views to give the full details of construction (see Figure 3.28). The two views usually include the front view and a right-side or left-side view, or a top or bottom view.

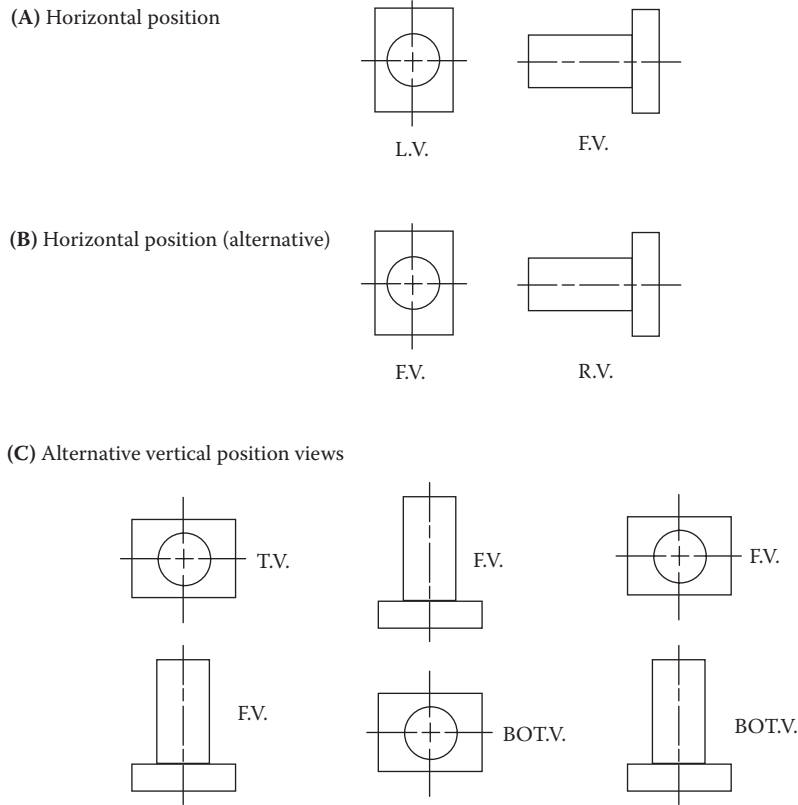

Figure 3.29 Several views for a two-view drawing of the same object.

Note: If an object requires only two views, and the left-side and right-side views are equally descriptive, the right-side view is customarily chosen. Similarly, if an object requires only two views, and the top and bottom views are equally descriptive, the top view is customarily chosen. Finally, if only two views are necessary, and the top view and right-side view are equally descriptive, the combination chosen is that which spaces best on the paper.

In the front view shown in Figure 3.28, the center lines run through the axis of the part as a horizontal center line. If the rotor shaft is in a vertical position, the center line runs through the axis as a vertical center line. The second view of the two-view drawing shown in Figure 3.28 contains a horizontal and a vertical center line intersecting at the center of the circles that make up the part in the view. Some of the two-view combinations commonly used in industrial blueprints are shown in Figure 3.29. In many two-view drawings, hidden edge or invisible edge lines, such as shown in Figure 3.30, are common. A hidden detail may be straight, curved, or cylindrical.

3.3.12.4 Three-View Drawings

Regularly shaped flat objects that require only simple machining operations are often adequately described with notes on a one-view drawing. Moreover, any two related views will show all three dimensions,

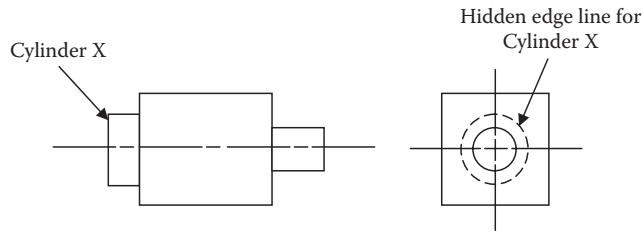

Figure 3.30 Two-view object with invisible edge lines.

but two views may not show enough detail to make the intentions of the designer completely clear. In addition, when the shape of the object changes, when portions are cut away or relieved, or when complex machine or fabrication processes must be represented on a drawing, the one view may not be sufficient to describe the part accurately. For this reason, a set of three related views has been established as the usual standard for technical drawings. The combination of front, top, and right-side views represents the method most commonly used by draftspersons to describe simple objects (see Figure 3.31). The object is usually drawn so its most important feature appears in the front view.

Note: Choosing the number and selection of views is governed by the shape or complexity of the object. A view should not be drawn unless it makes a drawing easier to read or furnishes other information required to describe the part clearly.

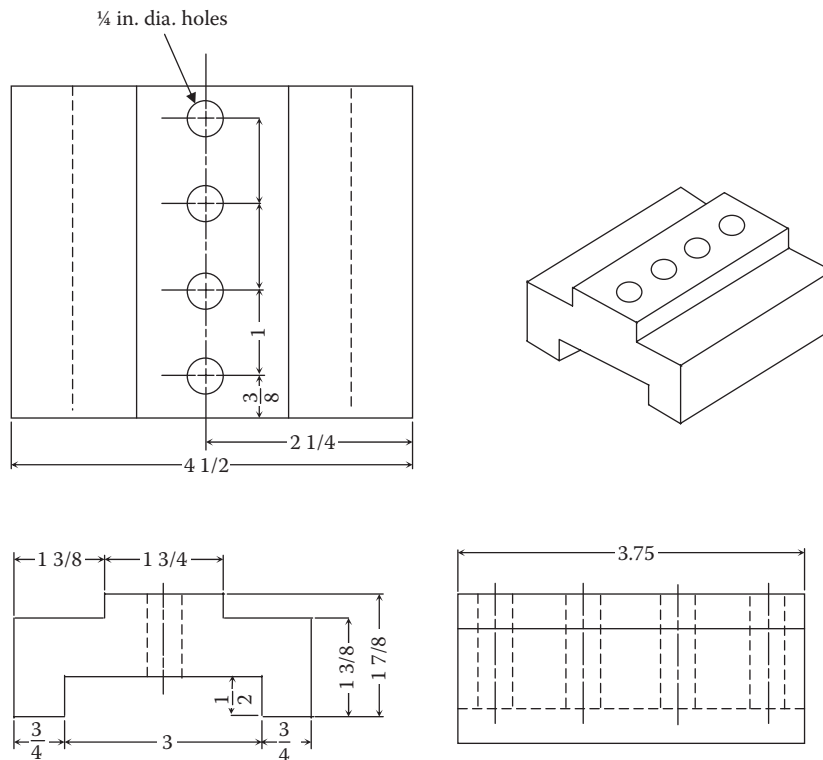

Figure 3.31 Three-view drawing.

3.3.12.5 Auxiliary Views

The purpose of the technical drawing is to show the size and shape of each surface. As long as all the surfaces of an object are parallel or at right angles to one another, they may be represented in one or more views. On occasion, however, even three views are not enough. To overcome this problem, draftspersons sometimes find it necessary to use *auxiliary* views of an object to show the shape and size of surfaces that cannot be shown in the regular view; that is, many objects are of such a shape that their principal faces cannot always be assumed to be parallel to the regular planes of projection.

If an object has a surface that is not at a 90° angle from the other surfaces, the drawing will not show its true size and shape; thus, an auxiliary view is drawn to overcome this problem. Figure 3.32A shows an object with an inclined surface (surface cut at an angle). Figure 3.32B shows the three standard views of the same object; however, because of the inclined surface of the object, it is impossible to determine its true size and shape. To show its true size and shape, the draftsperson draws an auxiliary view of the inclined surface. In Figure 3.33, the auxiliary view shows the inclined surface from a position perpendicular to the surface.

Note: Auxiliary views may be projected from any view in which the inclined surface appears as a line.

3.4 DIMENSION AND SHOP NOTES

Early on, dimensioning (or measuring using basic units of measurement) was rather simple and straightforward. For example, in the time of Noah and the Ark, a *cubit* was the length of a man's forearm, or about 18 inches. In preindustrialized England, an inch used to be "three barley corns, round and dry." More recently, we have all heard of "rule of thumb." At one time, an inch was defined as the width of a thumb, and a foot was simply the length of a man's foot. Although it is still somewhat common to hear some of these terms, dimensions today are normally stated somewhat differently. One major difference is in the adoption of

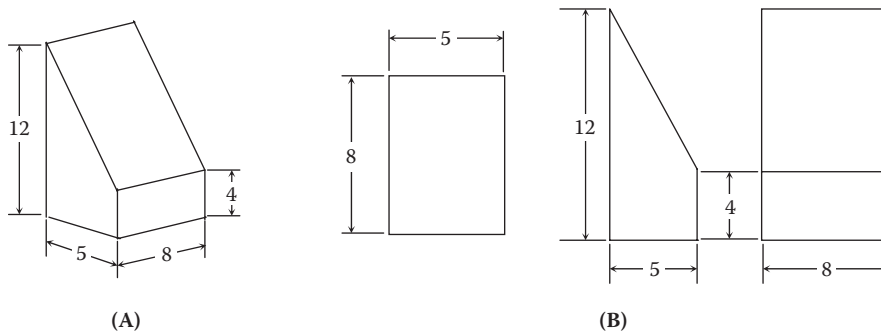

Figure 3.32 (A) Object with inclined surface; (B) three views of object with inclined surface.

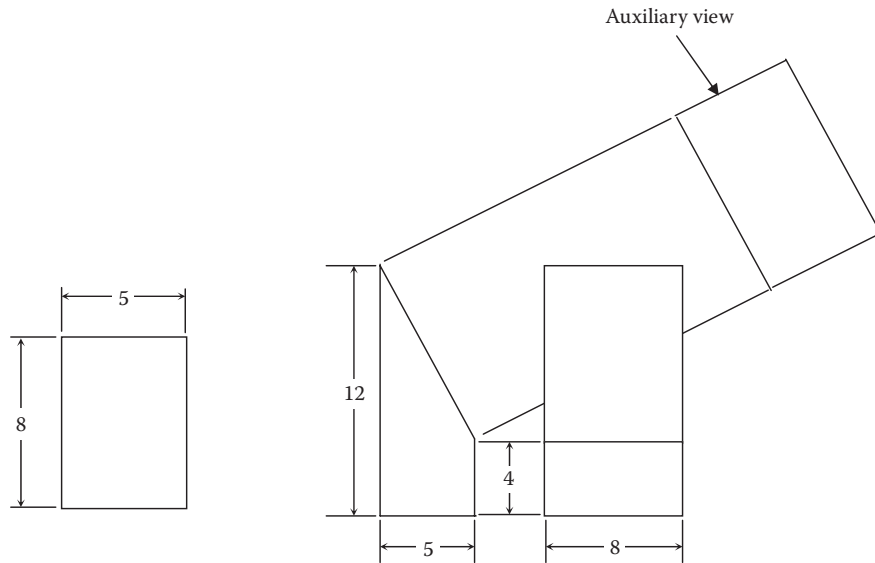

Figure 3.33 Object with inclined view shown in Figure 3.32 with auxiliary view added to give size and shape of inclined surface.

the standardized dimensioning units we currently use. This use came about because of the relatively recent rapid growth of worldwide science, technology, and commerce—all of which have fostered the International System of Units (SI) we use today.

3.4.1 Dimensioning

Technical drawings consist of several types of lines that are used singly or in combination with each other to describe the shape and internal construction of an object or mechanism; however, to rebuild a machine or remachine or reproduce a part, the blueprint or drawing must include dimensions that indicate the exact sizes and locations of surfaces, indentations, holes, and other details. Stated differently, in addition to a complete shape description of an object, a technical drawing of the object must also give a complete size description; that is, it must be *dimensioned*.

In the early days of industrial manufacturing, products were typically produced under one roof, often by one individual, using parts and subassemblies manufactured on the premises. Today, most major industries do not manufacture all of the parts and subassemblies in their products. Frequently, the parts are manufactured by specialty industries, to standard specifications or to specifications provided by the major industry.

Note: The key to successful operation of the various parts and subassemblies in a major product is being able to use two or more nearly identical duplicate parts individually in an assembly and have it function satisfactorily.

The modern practice of utilizing *interchanging* parts is the basis for the development of widely accepted methods for size description. Drawings today are dimensioned so machinists in widely separated places can make mating parts that will fit properly when brought together for final assembly in the factory or when replacement parts are used to make repairs to plant equipment. In today's modern wastewater treatment plant, the responsibility for size control has shifted from the maintenance operator to the draftsman. The operator no longer exercises judgment in engineering matters, but only in the proper execution of instructions given on the drawings.

Technical drawings show the object in its completed condition and contain all of the information necessary to bring it to its final state. A properly dimensioned drawing takes into account the shop processes required to finish a piece and the function of the part in assembly. Moreover, shop drawings are dimensioned for convenience for the shop worker or maintenance operator. These dimensions are given so it is not necessary to calculate, scale, or assume any dimensions. Designers and draftsmen provide dimensions that are neither irrelevant nor superfluous. Only those dimensions are given that are needed to produce and inspect the part exactly as intended by the designer. More importantly, only those dimensions are given that are needed by the maintenance operator who may have to rely on the blueprint (usually as a last resort) to determine the exact dimensions of the replacement part.

The meaning of various terms and symbols and conventions used in shop notes as well as procedures and techniques relating to dimensioning are presented in this chapter to assist the operator in accurately interpreting plant blueprints; however, before defining these important terms we must first discuss decimal and size dimensions.

3.4.2 Decimal and Size Dimensions

Dimensions may appear on blueprints as decimals, usually two-place decimals (normally given in even hundredths of an inch). In fact, it is common practice to use two-place decimals when the range of dimensional accuracy of a part is between 0.01 inch larger or smaller than nominal size (specified dimension). For more precise dimensions (e.g., dimensions requiring machining accuracies in thousandths or ten-thousandths of an inch), three- and four-place decimal dimensions are used. Every solid object has three size dimensions: depth (or thickness), length (or width), and height. In the case of the object shown in Figure 3.34, two of the dimensions are placed on the principal view and the third dimension is placed on one of the other views.

3.4.3 Definition of Dimensioning Terms

An old Chinese proverb states: "The beginning of wisdom is to call things by their right names." This statement is quite fitting because to satisfactorily read and interpret blueprints it is necessary to understand the terms relating to conditions and applications of dimensioning.

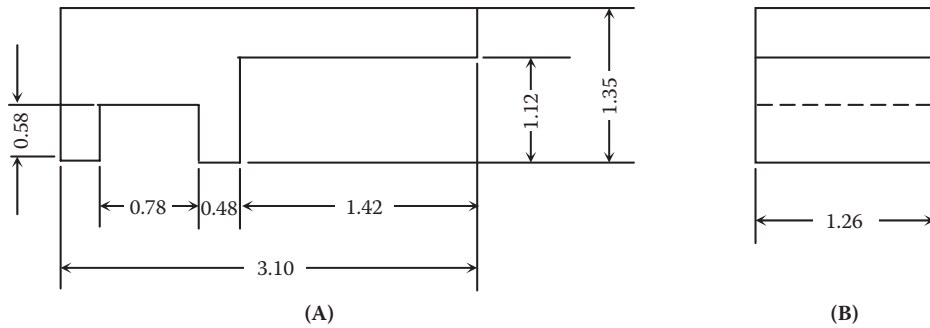

Figure 3.34 Size dimensions: (A) view with two size dimensions; (B) third side dimension on this view.

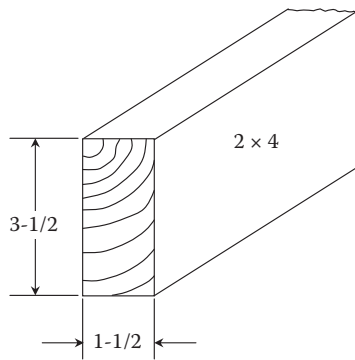

Figure 3.35 Nominal size of a 2×4 construction.

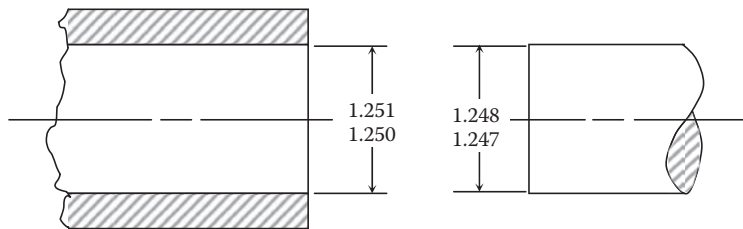

Figure 3.36 Nominal size 1-1/4".

3.4.3.1 Nominal Size

Nominal size is the designation that is used for the purpose of general identification. It may or may not express the true numerical size of the part or material. For example, the standard 2 × 4 stud used in building construction has an actual size of 1-1/2 × 3-1/2" (see Figure 3.35). In the case of the hole and shaft shown in Figure 3.36, however, the nominal size of both hole and shaft is 1-1/4", which would be 1.25" in a decimal system of dimensioning. So, again, it may be seen that the nominal size may or may not be the true numerical size of a material.

Note: When the term *nominal size* is used synonymously with *basic size*, we are to assume the exact or theoretical size from which all limiting variations are made.

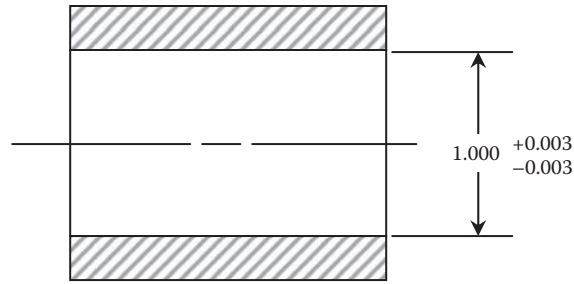

Figure 3.37 Basic size.

3.4.3.2 Basic Size

Basic size (or *dimension*) is the size of a part determined by engineering and design requirements. More specifically, it is the theoretical size from which limits of size are derived by the application of allowances and tolerances; that is, it is the size from which limits are determined for the size, shape, or location of a feature. For example, strength and stiffness may require a 1-inch-diameter shaft. The basic 1-inch size (with tolerance) will most likely be applied to the hole size because allowance is usually applied to the shaft (see Figure 3.37).

3.4.3.3 Allowance

Allowance is the designed difference in the dimensions of mating parts to provide for different classes of fit. Simply, it is the minimum clearance space (or maximum interference) of mating parts; consequently, it represents the tightest permissible fit and is simply the smallest hole minus the largest shaft. Recall that in Figure 3.37 we allowed 0.003 on the shaft for clearance ($1.000 - 0.003 = .997$) (see Figure 3.38).

3.4.3.4 Design Size

Design size is the size of a part after an allowance for clearance has been applied and tolerances have been assigned. The design size of the shaft shown in Figure 3.38 is .997 after the allowance of .003 has been made. A tolerance of $\pm .003$ is assigned after the allowance is applied (see Figure 3.39).

Note: After defining basic size and design size, the reader may be curious as to what the definition of *actual size* is. Actual size is simply the measured size.

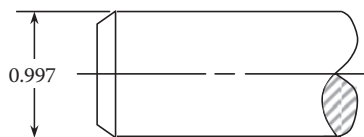

Figure 3.38 Design size (after application of allowance).

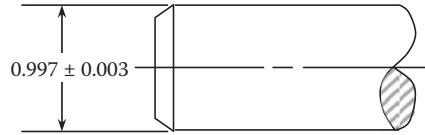

Figure 3.39 Design size (after allowance and tolerance are applied).

3.4.3.5 Limits

Limits are the maximum and minimum sizes indicated by a toleranced dimension; for example, the design size of a part may be 1.435. If a tolerance of plus or minus two-thousandths (± 0.002) is applied, then the two limit dimensions are the maximum limit of 1.437 and the minimum limit of 1.433 (see Figure 3.40).

3.4.3.6 Tolerance

Tolerance is the total amount by which a given dimension may vary, or the difference (variation) between limits (as shown in Figure 3.40). Tolerance should always be as large as possible, other factors considered, to reduce manufacturing costs. It can also be expressed as the design size followed by the tolerance (see Figure 3.41). Moreover, tolerance can be expressed when only one tolerance value is given, as the other value is assumed to be zero (see Figure 3.42). Tolerance is also applied to *location dimensions* for other features (e.g., holes, slots, surfaces) of a part (see Figure 3.43). (Note that location dimensions are usually made from either a center line or a finished surface; this practice is followed to overcome inaccuracies due to variations caused by surface irregularities.)

Because the size of the shaft shown in Figure 3.38 is 0.997 after the allowance has been applied, the tolerance applied must be below this size to ensure the minimum clearance (allowance) of 0.003. If a tolerance of ± 0.003 is permitted on the shaft, the total variation of 0.006 ($+0.003$ and -0.003) must occur between 0.997 and 0.994. Then, the design of the shaft is given a *bilateral tolerance* (where variation is permitted in both directions from the design size, as shown in Figure 3.41) vs. *unilateral tolerance* (where variation is permitted only in one direction from the design size, as shown in Figure 3.42).

Note: Tolerances may be specific and given with the dimension value or general and given by means of a printed note in or just above the title block.

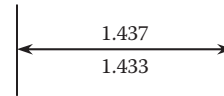

Figure 3.40 Tolerance that is expressed by limits.

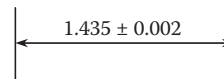

Figure 3.41 Design size with tolerance.

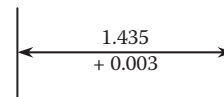

Figure 3.42 One tolerance value given.

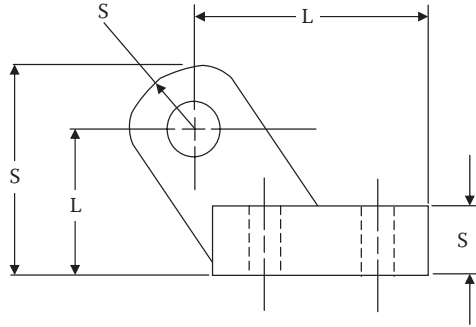

Figure 3.43 Size and location dimensions.

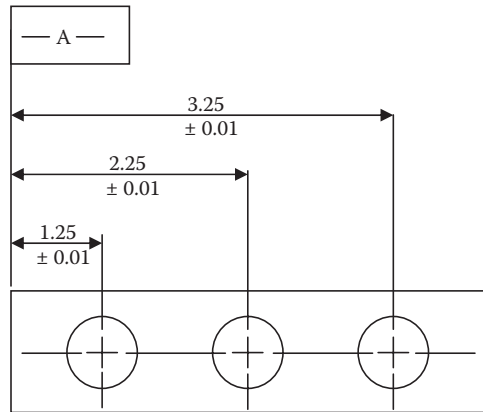

Figure 3.44 Dimensioning datum surface.

3.4.3.7 Datum

A datum (a point, axis, or plane) identifies the origin of a dimensional relationship between a particular (designated) point or surface and a measurement; that is, it is assumed to be exact for the purpose of reference and is the origin from which the location or geometric characteristic of features or a part are established. The datum is indicated by the assigned letter preceded and followed by a dash, enclosed in a small rectangle or box (see Figure 3.44).

3.4.4 Types of Dimensions

The types of dimensions include linear, angular, reference, tabular, and arrowless dimensions. Each of these is discussed in the following sections.

3.4.4.1 Linear Dimensions

Linear dimensions are typically used in aerospace, automotive, machine tool, sheet metal, electrical, electronics, and similar industries. Linear dimensions are usually given in inches for measurements of 72 inches and under, and in feet and inches if greater than 72 inches.

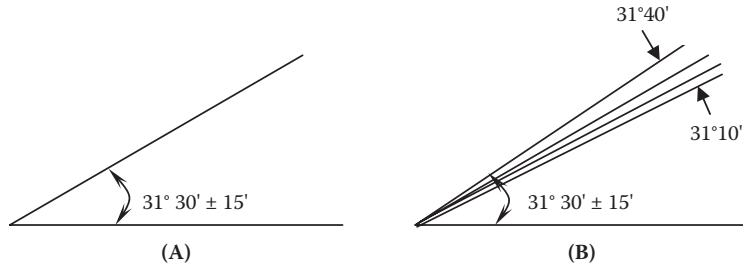

Figure 3.45 Angular dimensions and tolerance.

Note: In the construction and structural industries, linear dimensions are given in feet, inches, and common fractional parts of an inch.

3.4.4.2 Angular Dimensions

Angular dimensions are used on blueprints to indicate the size of angles in degrees (°) and fractional parts of a degree, minutes (') and seconds ("). Each degree is 1/360 of a circle. There are 60 minutes (') in each degree. Each minute may be divided into smaller units called seconds. There are 60 seconds (") in each minute. For example, 15 degrees, 12 minutes, and 45 seconds can be written 15°12'45". Current practice is to use decimalized angles. To convert angles given in whole degrees, minutes, and seconds, refer to the following example.

■ Example 3.1

Problem: Convert 15°12'45" into decimal degrees.

Solution: Convert minutes into degrees by dividing minutes by 60 (note that 60' = 1°):

$$12 \div 60 = .20^\circ$$

Convert seconds into degrees by dividing seconds by 3600 (note that 3600" = 1°):

$$45 \div 3600 = .01^\circ$$

Add the whole degrees plus decimal degrees:

$$15^\circ + .20^\circ + .01^\circ = 15.21^\circ$$

Therefore, 15°12'45" = 15.21° decimal degrees.

The size of an angle with the tolerance may be shown on the angular dimension itself (see Figure 3.45). The tolerance may also be given in a note on the drawing, as shown in Figure 3.46.

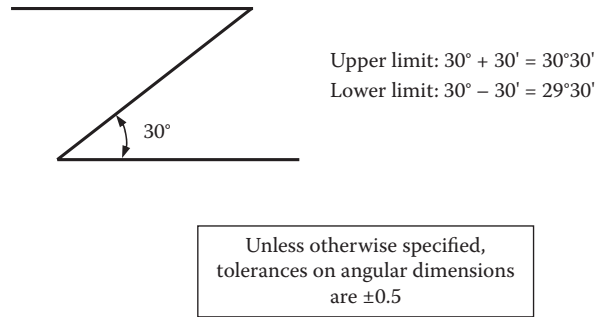

Figure 3.46 Tolerance specified as a note.

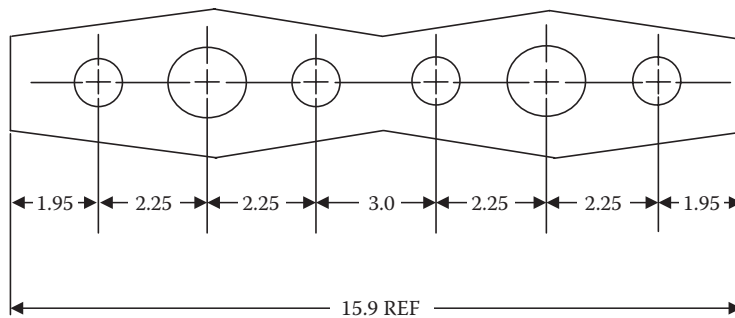

Figure 3.47 Dimensions for reference only.

Part No.	A	B	C	D	E
69-3705	0.650	1.00	1.250	0.158	0.890
69-3706	0.760	1.200	1.820	0.384	1.00
69-3707	0.800	1.300	2.160	0.496	1.115

Figure 3.48 Example table used for dimensioning a series of sizes.

3.4.4.3 Reference Dimensions

Reference dimensions are occasionally given on drawings for reference and checking purposes; they are given for information only. They are not intended to be measured and do not govern the shop operations. They represent the calculated dimensions and are often useful in showing the intended design size. Reference dimensions are marked by parentheses or followed by the notation “REF” (see Figure 3.47).

3.4.4.4 Tabular Dimensions

Tabular dimensions are used when a series of objects having like features but varying in dimensions may be represented by one drawing. Letters are substituted for dimension figures on the drawing, and the varying dimensions are given in tabular form (see Figure 3.48).

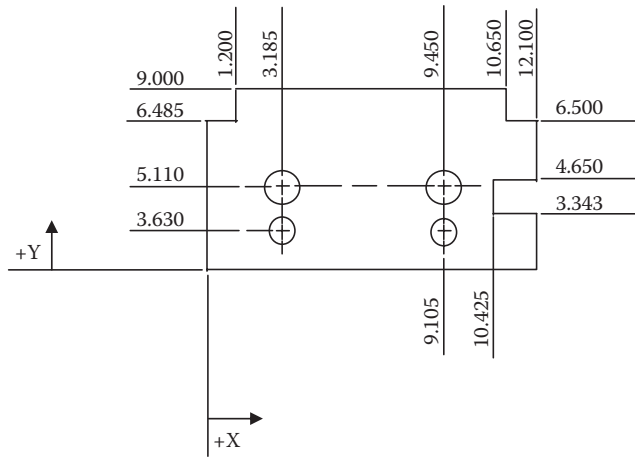

Figure 3.49 Application of arrowless dimensioning.

3.4.4.5 Arrowless Dimensions

Arrowless dimensions are frequently used on drawings that contain datum lines or planes (see Figure 3.49). This practice improves the clarity of the drawing by eliminating numerous dimension and extension lines.

3.4.5 Shop Notes

To convey the information the machinist needs to make a part, the draftsman typically uses notes. Notes such as those used for reaming, counterboring, drilling, or countersinking holes are added to ordinary dimensions. The order of items in a note corresponds to the order of procedures to be done in the shop. Two or more holes are dimensioned by a single note, the leader pointing to one of the holes. A note may consist of a very brief statement at the end of a leader, or it may be a complete sentence that gives an adequate picture of machining processes and all necessary dimensions. On drawings of parts to be produced in large quantity for interchangeable assembly, dimensions and notes may be given without specifying the shop process to be used. A note is placed on a drawing near the part to which it refers.

Note: Notes should always be lettered horizontally on the drawing paper, and guide lines should always be used.

3.5 MACHINE DRAWINGS

Your ability to work with machines depends on your ability to understand them. If wastewater maintenance operators know how the parts of a machine fit together and how they are intended to work together, they are better able to operate the machine, perform proper preventive maintenance on it, and repair it when it breaks down. At larger plants, no one can possibly know all the details of every machine or machine tool. There are too many variations among machines of the same type.

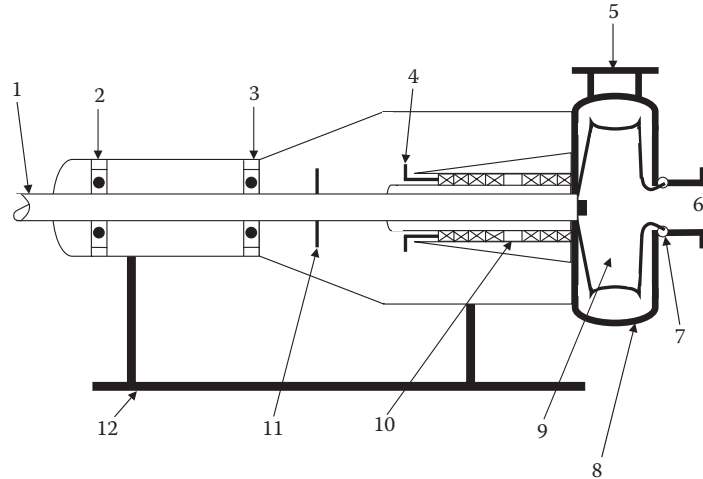

Figure 3.50 Major components of a centrifugal pump.

All centrifugal pumps, for example, do the same basic work, but the many different manufacturers of centrifugal pumps offer several different models and sizes. It would be difficult to understand all of the different centrifugal pumps without being able to read blueprints or basic machine drawings (such as those depicted in this chapter).

We have chosen, along with a standard centrifugal pump, a submersible pump, a turbine pump, and a simple solid packed stuffing box assembly as the machines to refer to for our discussion on how to read simple machine drawings. We chose these machines and the stuffing box assembly because they are among the most familiar of all machines and assemblies in wastewater treatment operations. The reader will see how the parts that make up various pumps and pump mechanisms are represented on simplified assembly drawings. Understanding these simplified drawings will add an important tool to the reader's toolbox.

3.5.1 The Centrifugal Pump Drawing (Simplified)

Figure 3.50 shows a simplified assembly drawing of a standard centrifugal pump used in wastewater treatment and collection.

3.5.1.1 The Centrifugal Pump

The centrifugal pump is the most widely used type of pumping equipment in the wastewater industry. Pumps of this type are capable of moving high volumes of wastewater in a relatively efficient manner. The centrifugal pump is very dependable, has relatively low maintenance requirements, and can be constructed out of a wide variety of materials. The centrifugal pump is available in a wide range of sizes, with capacities ranging from a few gallons per minute up to several thousand pounds per square inch (Cheremisinoff and Cheremisinoff, 1989). The centrifugal pump is considered one of the most dependable systems available for water and wastewater liquid transfer.

3.5.1.2 Centrifugal Pump: Description

The centrifugal pump consists of a rotating element (impeller) sealed in a casing (volute). The rotating element is connected to a drive unit or prime mover (motor/engine) that supplies the energy to spin the rotating element. As the impeller spins inside the volute casing, an area of low pressure is created in the center of the impeller. This pressure allows the atmospheric pressure on the water in the supply tank to force the water up to the impeller. (Note that the term *water* in our discussion includes both freshwater [potable] and wastewater, unless otherwise specified.) Because the pump will not operate if no low-pressure zone is created at the center of the impeller, it is important that the casing be sealed to prevent air from entering the casing. To ensure that the casing is airtight, the pump includes some type of seal (mechanical or conventional packing) assembly at the point where the shaft enters the casing. This seal also includes some type of lubrication (water, grease, or oil) to prevent excessive wear.

When water enters the casing, the spinning action of the impeller transfers energy to the water. This energy is transferred to the water in the form of increased speed or velocity. The water is thrown outward by the impeller into the volute casing; the design of the casing allows the velocity of the water to be reduced, which, in turn, converts the velocity energy (velocity head) to pressure energy (pressure head). The water then travels out of the pump through the pump discharge. The major components of the centrifugal pump are shown in Figure 3.50.

3.5.1.3 Centrifugal Pump: Components

Refer back to Figure 3.50 for a simplified representation of the major components that make up a standard centrifugal pump. This is the type of drawing typically used to train maintenance operators, in the classroom, on the centrifugal pump. It also serves as a basic shop assembly drawing showing how each of the components is related relative to each other. Figure 3.50 shows all of the parts that typically come in contact with one another in their assembled positions. Notice that all of the key components shown in Figure 3.50 are numbered. For this type of drawing, this is standard practice. Usually, along with the view of the numbered components, a key is provided on the drawing that identifies each numbered part. For the purpose of simplification, each component of the centrifugal pump in Figure 3.50 is numbered as follows:

- 1 Shaft
- 2 Thrust bearing
- 3 Radial bearing
- 4 Packing gland
- 5 Discharge
- 6 Suction
- 7 Impeller wear ring
- 8 Volute

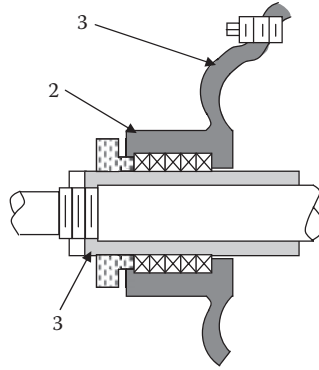

Figure 3.51 Solid packed stuffing box.

- 9 Impeller
- 10 Stuffing box
- 11 Slinger ring
- 12 Pump frame

3.5.2 Packing Gland Drawing

The pump packing gland is part of the stuffing box and seal assembly. Such sealing devices are used on pumps to prevent water leakage along the pump driving shaft (component 1 in Figure 3.50 and component 3 in Figure 3.51). Shaft sealing devices must control water leakage without causing wear to the pump shaft. Two systems are available to accomplish this seal: the conventional stuffing box/packing assembly and the mechanical seal assembly.

Note: We have included an elementary drawing of a packing gland in this text (see Figure 3.51) because it is a critical pump component with which all maintenance operators become familiar, sooner rather than later, in their tenure.

The *stuffing box* of a centrifugal pump is a cylindrical housing, the bottom of which may be the pump casing, a separate throat bushing attached to the stuffing box, or a bottoming ring. Stuffing boxes for pumps used in wastewater treatment processes are available in a number of designs. Generally, at the top of the stuffing box is a *packing gland* (see Figure 3.51). The gland encircles the pump shaft sleeve and is cast with a flange that slips securely into the stuffing box. Stuffing box glands are manufactured as a single piece split in half and held together with bolts. The advantage of the split gland is being able to remove it from the pump shaft without dismantling the pump. In Figure 3.51, each numbered component is identified as follows:

- 1 Pump housing
- 2 Packing gland
- 3 Shaft sleeve

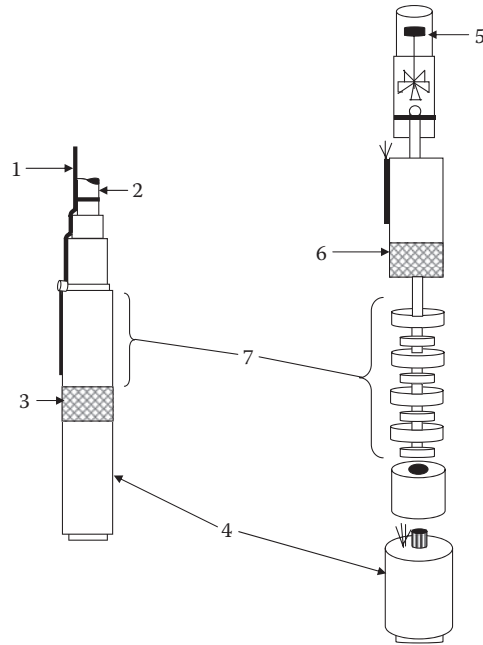

Figure 3.52 Submersible pump.

3.5.3 Submersible Pump Drawing (Simplified)

The submersible pump is another machine familiar to most wastewater maintenance operators; it is used extensively in both industries. The submersible pump is, as the name suggests, placed directly in deep wells and pumping station wet wells. In some cases, only the pump is submerged; in other cases, the entire pump–motor assembly is placed in the well or wet well. A simplified drawing of a typical submersible pump is shown in Figure 3.52, where each numbered component is identified as follows:

- 1 Electrical connection
- 2 Drop pipe
- 3 Inlet screen
- 4 Electric motor
- 5 Check valve
- 6 Inlet screen
- 7 Bowls and impellers

3.5.4 Turbine Pump Drawing (Simplified)

The turbine pump is another familiar type of pump. It consists of a motor, drive shaft, a discharge pipe of varying lengths, and one or more impeller–bowl assemblies. It is normally a vertical assembly in which the water enters at the bottom, passes axially through the impeller–bowl

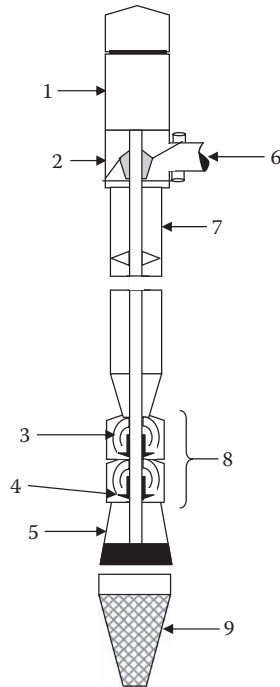

Figure 3.53 Vertical turbine pump.

assembly where the energy transfer occurs, then moves upward through additional impeller–bowl assemblies to the discharge pipe. The length of this discharge pipe will vary with the distance from the wet well to the desired point of discharge; see Figure 3.53, where each numbered component is identified as follows:

- 1 Hollow motor shaft
- 2 Stuffing box
- 3 Bowl
- 4 Impeller
- 5 Suction bell
- 6 Discharge head
- 7 Driving shaft
- 8 Pump unit
- 9 Screen

3.6 SHEET METAL DRAWINGS

Some wastewater maintenance work may involve making simple pieces of equipment for the plant. Much of this equipment is made from sheet metal. To use the sheet metal correctly, maintenance operators need to know how to read basic drawings.

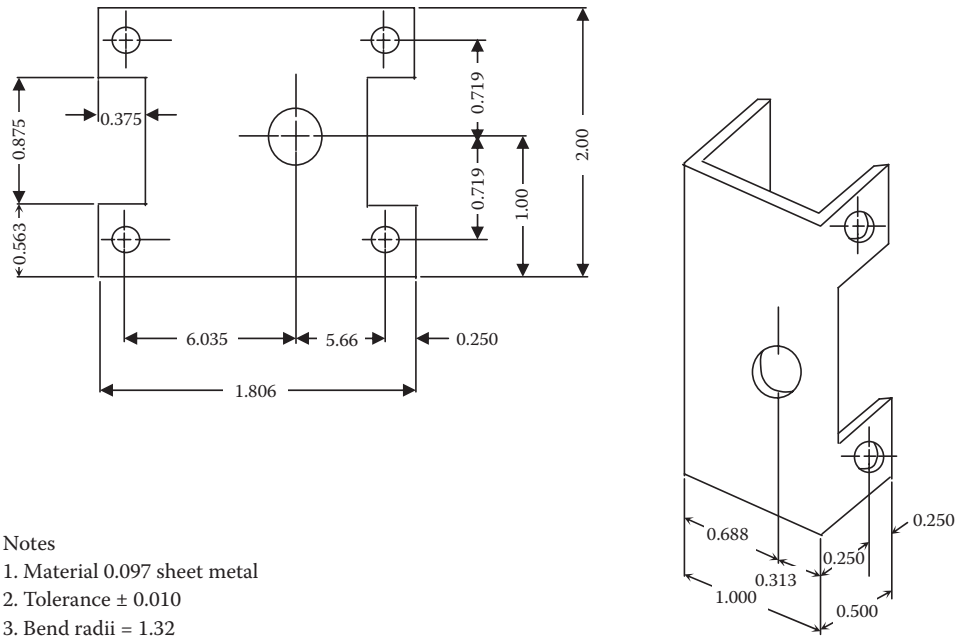

Figure 3.54 Sheet metal part.

3.6.1 Sheet Metal

Thin-gauged metals, such as sheet metal, which is made from sheet stock (metal that has been rolled into sheet stock), are used in water and wastewater treatment operations to fabricate many objects and devices. Examples include safety guards, shelves, machinery cover plates, brackets for tools and parts, and ducts for heating and air conditioning units.

Note: Wide rolls of sheet stock (steel, aluminum, copper, and brass) are called *coils*. When sheet stock is cut into rectangular sections, it is referred to as *sheet metal*.

Sheet metal is plain metal with very little surface protection or is covered with a thin protective coat of zinc (galvanized) to prevent rusting. Typically, in wastewater treatment operations, either galvanized or aluminum sheet metal is used. Sheet metal drawings tell maintenance operators what they need to know to fabricate various kinds of objects and devices. Typically, the calculations and layout on the drawings are exact. On many occasions, the metal is machined in a flat position and then folded or assembled, so the relationship and location of the resulting planes and features must be within their specified tolerances (see Figure 3.54).

3.6.1.1 Dimension Calculations

As mentioned, blueprints are usually dimensioned in the flat layout form by the draftsman to achieve the desired dimension of the device and its features after it is folded or assembled. However, as most

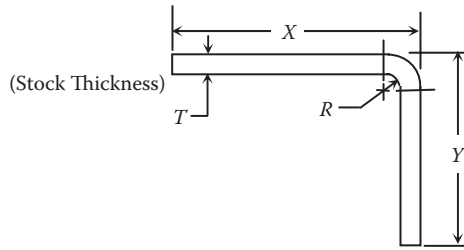

Figure 3.55 Diagram for calculating developed length from a set-back table.

maintenance operators know, there are exceptions to this practice. In the event that dimensions must be calculated in the shop or field, it is helpful to know how to make these calculations (Brown, 1989).

3.6.1.2 Calculations for Allowances in Bend

Calculations for allowances in bend radii may be obtained in two ways: (1) directly from a set-back table or (2) by use of a mathematical formula. Set-back tables are available from sheet metal suppliers.

3.6.1.3 Set-Back Table

The diagram (from which the formula $X + Y - Z$ is derived) shown in Figure 3.55 shows the application of the set-back value to calculating the flat length (developed length; see note below) to produce the desired folded size of a sheet metal part or device.

Note: Laying out a three-dimensional shape on a flat surface is a technique called *development*. To make something out of sheet metal, we must first lay out the development on a flat sheet known as a *template*. We then place the template on a piece of sheet metal, cut the metal to the proper shape, and bend it to form the three-dimensional piece we want.

■ Example 3.2

Problem: Using Figure 3.56, find the developed length.

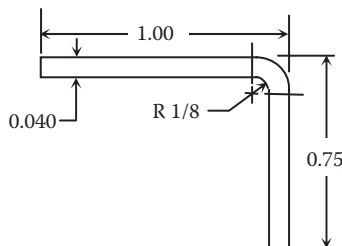

Figure 3.56 Illustration for Example 3.2.

Solution:

$$\text{Developed Length} = X + Y - Z$$

$$\text{Developed Length} = 1.00 + .75 - .106 = 1.75 - .106 = 1.64 \text{ (rounded)}$$

3.6.1.4 Formulae Used to Determine Developed Length

One of two formulae can be used to calculate the developed length. The formulae used first calculate the *linear length* of sheet metal parts, depending on the size of the bend radius and the thickness of the metal, then the developed length. Figure 3.57 shows the diagram used for calculating the developed length. The two formulae that can be used to make this calculation are as follows:

When R is less than twice the stock thickness:

$$A = 1/2\pi(R + .4T) \quad (3.1)$$

When the bend radius is more than twice the stock thickness:

$$A = 1/2\pi(R + .5T) \quad (3.2)$$

where:

A = linear length of a 90° bend.

R = inside radius.

T = material thickness.

After determining A (linear bend length), the developed length of the part or device is determined using the following formula (refer to the diagram in Figure 3.57):

$$\text{Developed Length} = X + Y + A - (2R + 2T) \quad (3.3)$$

Note: The two formulae shown above are provided for informational purposes only. For our purposes, the same answer that can be obtained in shorter time using a sheet metal set-back table. In the shop or field (i.e., in actual practice), the set-back table is most commonly used.

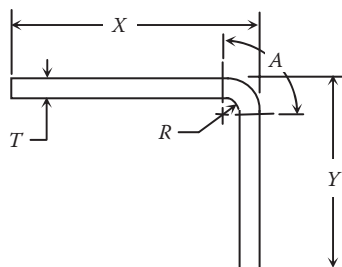

Figure 3.57 Diagram used for calculating the developed length.

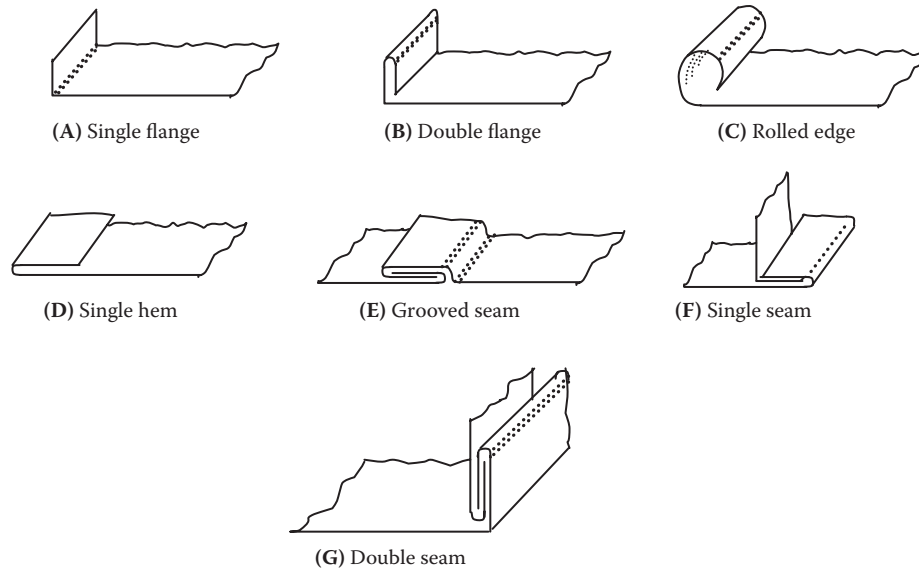

Figure 3.58 Examples of sheet metal hems and joints.

3.6.2 Hems and Joints

Keeping in mind that the development of a sheet metal surface is that surface laid out on a plane, a wide variety of hems and joints can be used in the fabrication of these sheet metal developments (see Figure 3.58). *Hems* are used to eliminate the raw edge and also to stiffen the material. The need to eliminate raw edges and stiffen sheet metal can, for example, best be seen in the use of sheet metal to fabricate ventilation ducts. To ensure efficient ventilation operation, the ductwork through which the air is conveyed must be smooth to reduce turbulence and mechanically strong enough to stand up to internal and external forces. In the development of sheet metal surfaces, *joints* (seams) may be made by bending, welding, riveting, or soldering.

Note: In the fabrication of sheet metal developments, sufficient material as required for hems and joints must be added to the layout or development. The amount of allowance depends on the thickness of the material and the production equipment.

3.7 HYDRAULIC AND PNEUMATIC DRAWINGS

Hydraulic and pneumatic power systems are widely used in water and wastewater treatment operations. They operate small tools and large machines. Maintenance operators must know how these fluid power systems work to be able to repair and maintain them; however, before attempting to understand and service fluid power systems, it is necessary to also know how to read hydraulic and pneumatic drawings. Although it is not our purpose in this section to make fluid mechanics experts out of anyone (e.g., able to discuss such fluid principles as Pascal's law and multiplying forces), we do intend to explain the basics of hydraulic and pneumatic systems.

Many machines and tools used in wastewater treatment are operated by *hydraulic* and *pneumatic* power systems. These systems transmit forces through a *fluid* (defined as either a gas or a liquid). Power plungers, power bar screen assemblies, fluid-drive transmissions, hydraulic lifts and racks, air brakes, and various heavy-duty power tools are examples of hydraulic and pneumatic power systems. Air-powered drills and grinders are tools that operate on compressed air. Larger pneumatic devices are used on larger machines. Because all of these mechanisms must be maintained and repaired, we need to know how they operate. Moreover, we must also be able to read and interpret the drawings that show the construction of these systems.

3.7.1 Standard Hydraulic System

A standard hydraulic system operates by means of a *liquid* (hydraulic fluid) under pressure. A basic hydraulic system has five components:

- *Reservoir*—Provides storage space for the liquid
- *Pump*—Provides pressure to the system
- *Piping*—Directs fluid through the system
- *Control valve*—Controls the flow of fluid
- *Actuating unit*—Reacts to the pressure and does some kind of useful work

Because the hydraulic fluid never leaves the system, it is a *closed system*. The hydraulic system on a forklift is an example of a hydraulic system.

3.7.2 Standard Pneumatic System

A standard pneumatic system operates by means of a *gas* under pressure. The gas is usually dry air. A basic pneumatic system is very much like the hydraulic system described above and includes the following main components:

- *Atmosphere*—Serves the same function as the reservoir of the hydraulic system
- *Intake pipe and filter*—Provides a passage for air to enter the system
- *Compressor*—Compresses the air, putting it under pressure; its counterpart in the hydraulic system is the pump
- *Receiver*—Stores pressurized air until it is needed; it helps provide a constant flow of pressurized air in situations where air demand is high or varies
- *Relief valve*—Can be set to open and bleed off some of the air if the pressure becomes too high
- *Pressure-regulating valve*—Ensures that the air delivered to the actuating unit is at the proper pressure
- *Control valve*—Provides a path for the air to the actuating unit

Note: Pneumatic systems are usually *open* systems (i.e., the air leaves the system after it is used).

3.7.3 Hydraulic and Pneumatic Systems: Similarities and Differences

With regard to their similarities, both hydraulic and pneumatic systems use a pressure-building source, which can be either a pump or a compressor. They both also require either a reservoir or a receiver to store the fluid. In addition, they require valves and actuators and lines to connect these components in a system. The motion that results from the actuator may be either straight line (linear) or circular (rotary). With regard to their differences, we must note an important difference between a liquid (for hydraulic systems) and a gas (for pneumatic systems). A liquid is difficult to compress; water, for example, cannot be compressed into a space that is noticeably smaller in size. On the other hand, a gas is easy to compress; for example, a large volume of air from the atmosphere can be compressed into a much smaller volume.

3.7.4 Types of Hydraulic and Pneumatic Drawings

Several types of drawings are used to show instrumentation, control circuits, and hydraulic or pneumatic systems. These include graphic, pictorial, cutaway, and combination drawings:

- *Graphic drawings* consist of graphic symbols joined by lines that provide an easy method of emphasizing functions of the system and its components (see Figure 3.59).
- *Pictorial drawings* are used when piping is to be shown between components (see Figure 3.60).
- *Cutaway drawings* consist of cutaway symbols of components and emphasize component function and piping between components (see Figure 3.61).
- *Combination drawings* utilize, in one drawing, the type of component illustration that best suits the purpose of the drawing (see Figure 3.62).

The emphasis in this section will be on graphic diagrams, as these are the most widely used in wastewater operations and the graphic symbols have been standardized.

3.7.5 Graphic Symbols for Fluid Power Systems

You may or may not have had difficulty reading any of the four types of drawings shown in Figures 3.59 through 3.62; however, unless you were familiar with the basic symbols used in the drawings, you probably did have some difficulty understanding them.

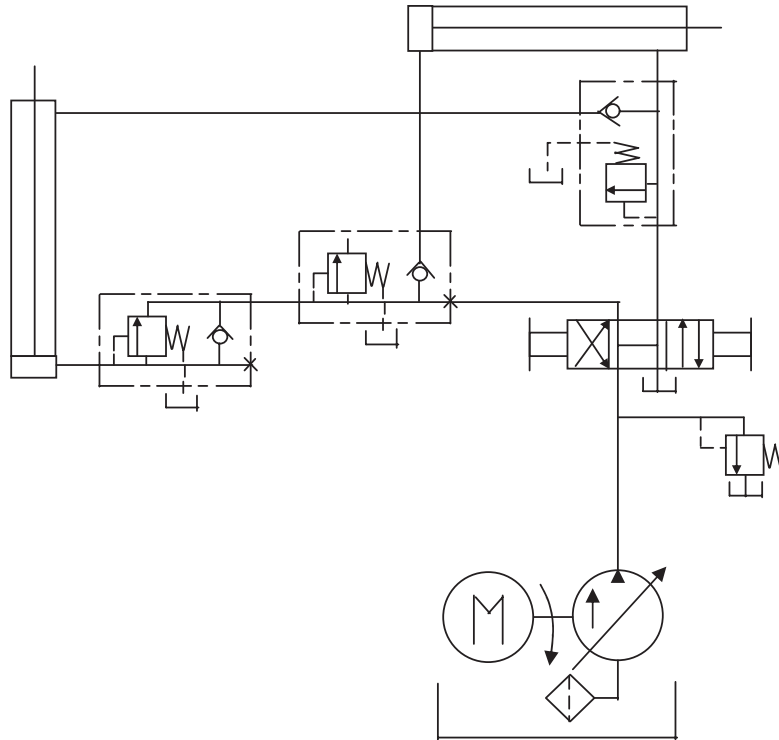

Figure 3.59 Graphic drawing for a fluid power system.

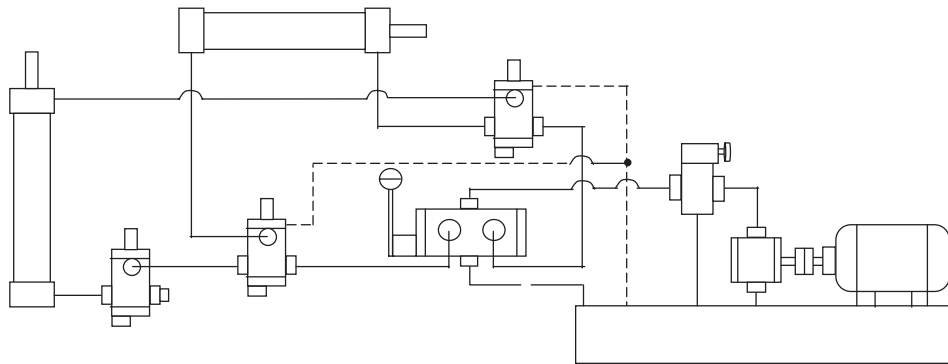

Figure 3.60 Pictorial drawing for a fluid power system.

3.7.5.1 Symbols for Methods of Operation (Controls)

Figure 3.63 shows the standard graphic symbols used in hydraulic and pneumatic system diagrams for methods of operation (controls).

3.7.5.2 Symbols for Rotary Devices

Figure 3.64 shows the standard graphic symbols used in hydraulic and pneumatic system diagrams for rotary devices, such as pumps, motors, oscillators, and internal combustion engines.

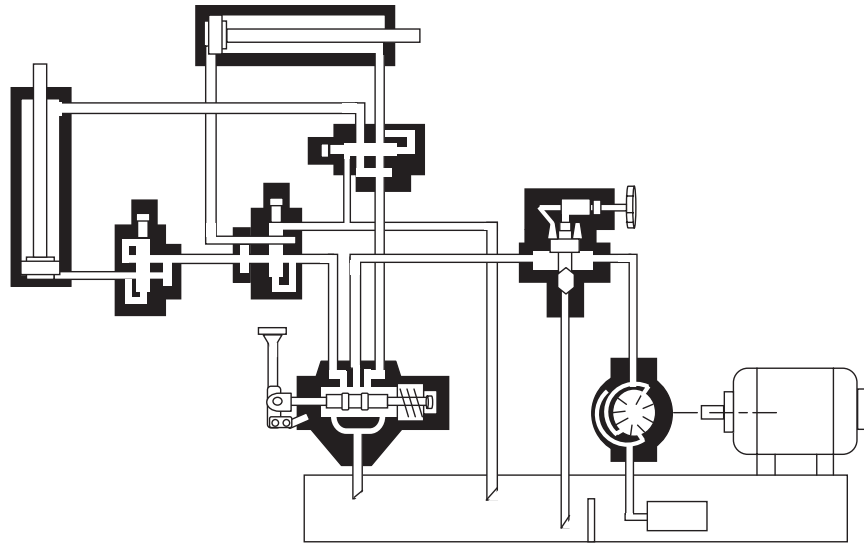

Figure 3.61 Cutaway drawing of a fluid power system.

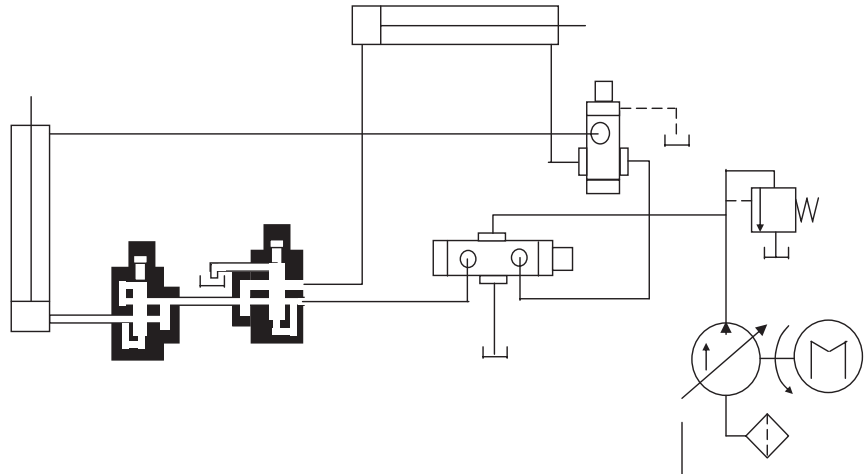

Figure 3.62 Combination drawing of a fluid power system.

Spring		Detent	
Manual		Pressure-compensated	
Push button		Solenoid, single winding	
Push-pull lever		Reversing motor	
Pedal or treadle		Pilot pressure	
Mechanical		Remote supply	
		Internal supply	

Figure 3.63 Symbols for methods of operation.







Hydraulic pump Fixed displacement		Cylinder, single-acting	
Variable displacement		Cylinder, double-acting	
Hydraulic motor		Single end rod	
Fixed displacement		Double end rod	
Variable displacement		Adjustable cushion advance only	
		Differential piston	

Figure 3.64 Symbols for rotary devices.

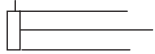

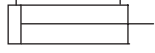

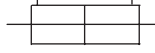

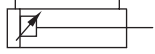
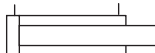







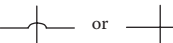

Line, working (main)		Line, pilot (for control)	
Line, liquid drain		Line with fixed restrictions	
Lines crossing		Lines joining	
Line, flexible		Temperature cause or effect	
Variable component (run arrow through symbol at 45°)		Station, testing, measurement, or power take-off	
Vented manifold		Pressure-compensated units (arrow are parallel to short side of symbol)	
Flow, direction of			
Hydraulic			
Pneumatic			
Reservoir		Line, to reservoir	
Vented 	Pressurized 	Above fluid level 	Below fluid level 

Figure 3.65 Symbols for system lines.

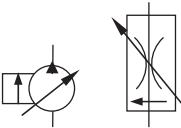
3.7.5.3 Symbols for Lines

Figure 3.65 shows the standard graphic symbols used in hydraulic and pneumatic system diagrams for system lines.

3.7.5.4 Symbols for Valves

Figure 3.66 shows the standard graphic symbols used in hydraulic and pneumatic system diagrams for valves.

3.7.5.5 Symbols for Miscellaneous Units

Figure 3.67 shows the standard graphic symbols used in hydraulic and pneumatic system diagrams for miscellaneous units, such as energy storage and fluid storage devices.







Check		Flow control, adjustable(noncompensated)	
On/off (manual shut-off)		Flow control, adjustable (temperature and pressure compensated)	
Pressure relief		Two-position, two connection	
Pressure reducing		Two-position, three connection	

Figure 3.66 Symbols for valves.





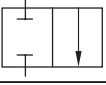

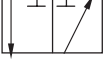

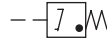

Electric motor		Filer, strainer	
Accumulator, spring-loaded		Pressure switch	
Accumulator, gas-charged		Pressure indicator	
Heater		Temperature indicator	
Cooler		Component enclosure	
Temperature controller		Direction of shaft rotation (assume arrow on near side of shaft)	

Figure 3.67 Miscellaneous symbols.

3.7.6 Supplementary Information Accompanying Graphic Drawings

Once we have become familiar with the symbols used in graphic drawings, the drawings are relatively easy to read and understand. In addition to the graphic drawing, prints of hydraulic and pneumatic systems usually include a listing of the sequence of operations, solenoid chart, and parts used to facilitate understanding of the function and purpose of the system and its components.

3.7.6.1 Sequence of Operations

A listing of the sequence of operations is an explanation of the various functions of the system explained in order of occurrence. Each phase of the operation is numbered or lettered and a brief description is given of the initiating and resulting action.

Note: A listing of the sequence of operations is usually given in the upper part of the print or on an attached sheet.

3.7.6.2 Solenoid Chart

If solenoids are used in the instrumentation or control circuits of a hydraulic or pneumatic system, a chart is normally located in the lower left corner of the print to help explain the operation of the electrically controlled circuit.

Note: Solenoids are usually given a letter on the drawings, and the chart shows where the solenoids are energized (+) or de-energized (-) at each phase of system operation.

3.7.6.3 Bill of Materials

The bill of materials, sometimes referred to as a *component or parts list*, includes an itemized list of the several parts of a structure or device shown on a graphic detail drawing or a graphic assembly drawing. This parts list usually appears right above the title block; however, this list is also often given on a separate sheet. Parts lists on machine drawings contain the part numbers or symbols, a descriptive title of each part, the quantity required, the material specified, and frequently other information, such as pattern numbers, stock sizes of materials, and weights of parts.

Key Point: The title strip alone is sufficient on graphic detail drawings of only one part, but a parts list is necessary on graphic detail drawing of several parts.

Note: Parts are listed in general order of size or importance; for example, the main castings or forgings are listed first, parts cut from cold-rolled stock second, and standard parts such as bushings and roller bearings third.

3.8 WELDING BLUEPRINTS AND SYMBOLS

Wastewater maintenance operators may be called upon to perform welding operations. In many cases, the operator/welder is required to do nothing more than tack pieces of metal together—a very basic operation; however, occasionally a welding job must be performed precisely according to the specifications of the designer. Obviously, the strength and durability of the piece to be welded depend on the ability of the operator/welder to make the welds properly.

The designer of a part communicates the welding specifications by means of blueprints or drawings. Special symbols on the drawing provide all the information required concerning the preparation of the parts to be welded, the kind of welding to be performed, which side to weld from, how to shape the weld, and how to finish the welded surface. Operators or welders who cannot understand all of the information contained in the symbol will not be able to perform the welds properly. Because welding is used so extensively in wastewater operations for so large a variety of purposes, it is essential to have an accurate method of showing the exact types, sizes, and locations of welds on the working

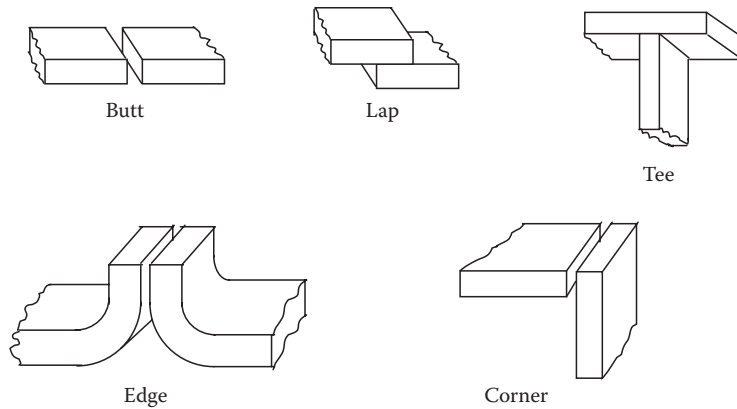

Figure 3.68 Basic weld joints.

drawings of machines and plant equipment. In the past, many parts were cast in foundries. These parts are now being constructed by welding. To provide a means for placing complete welding information on the drawing in a simple manner, a system of welding symbols was developed by the ASW in conjunction with ANSI (ANSI/AWS, 1991). The welding symbols included in this section will assist in reading and interpreting blueprints and drawings involving welding processes.

3.8.1 Welding Processes

The American Welding Society defines *welding* as “a joining process that produces coalescence of materials by heating them to the welding temperature, with or without the application of pressure or by the application of pressure alone, and with or without the use of filler metal” (AWS, 1996). Three of the principal methods of welding are the oxyacetylene method, generally known as *gas welding*; the electric-arc method, generally known as *arc welding*; and *electric-resistance welding*. The first two are the most widely used welding processes for maintenance welding; the high temperatures necessary for fusion are obtained with a gas flame in oxyfuel welding and with an electric arc in arc welding. Electric-resistance welding, generally referred to as *resistance welding*, requires electricity and the application of pressure to make welded joints. Resistance welding is primarily a production welding operation; it is rarely used in wastewater maintenance operations.

3.8.2 Types of Welded Joints

A welded joint is the union of two or more pieces of metal by means of a welding process. Five basic types of welded joints are specified on drawings. Each type of joint is identified by the position of the parts to be joined together. Parts that are welded by using butt, corner, tee, lap, or edge joints are illustrated in Figure 3.68. Each of these joints has several variations.

Note: Various types of welds are applicable to each type of joint, depending on the thickness of metal and the strength of the joint required, among other considerations.

3.8.2.1 Butt Joints

Butt joints join the edges of two metals that are placed against each other end to end in the same plane. The joint is reasonably strong in static tension but is not recommended when it is subjected to fatigue or impact loads, especially at low temperatures. The preparation of the joint is relatively simple, as it requires only matching the edges of the plates; consequently, the cost of making the joint is low. These joints are frequently used for plate, sheet metal, and pipe work (see Figure 3.68).

3.8.2.2 Lap Joints

A lap joint, as the name implies, is made by connecting overlapping pieces of metal, which are often part of a structure or assembly. The lap joint is popular because it is strong and easy to weld. Moreover, special beveling or edge preparations are seldom necessary. For joint efficiency, an overlap greater than three times the thickness of the thinnest member is recommended. Lap joints are common in torch brazing processes, for which filler metal is drawn into the joint area by capillary action, and in sheet metal structures fabricated with the spot welder (see Figure 3.68).

3.8.2.3 Tee Joints

A tee joint (which, as the name implies, is T-shaped) is made by placing the edge of one piece of metal on the surface of the other piece at approximately a 90° angle. It is used for all ordinary plate thicknesses (see Figure 3.68).

3.8.2.4 Edge Joints

The edge joint is suitable for plate 1/4 inch or less in thickness and can sustain only light loads. These joints are made when one or more of the pieces to be connected is flared or flanged (see Figure 3.68).

3.8.2.5 Corner Joints

L-shaped corner joints have wide applications in joining sheet and plate metal sections where generally severe loads are not encountered. Boxes, trays, low-pressure tanks, and other objects are made with corner joints (see Figure 3.68).

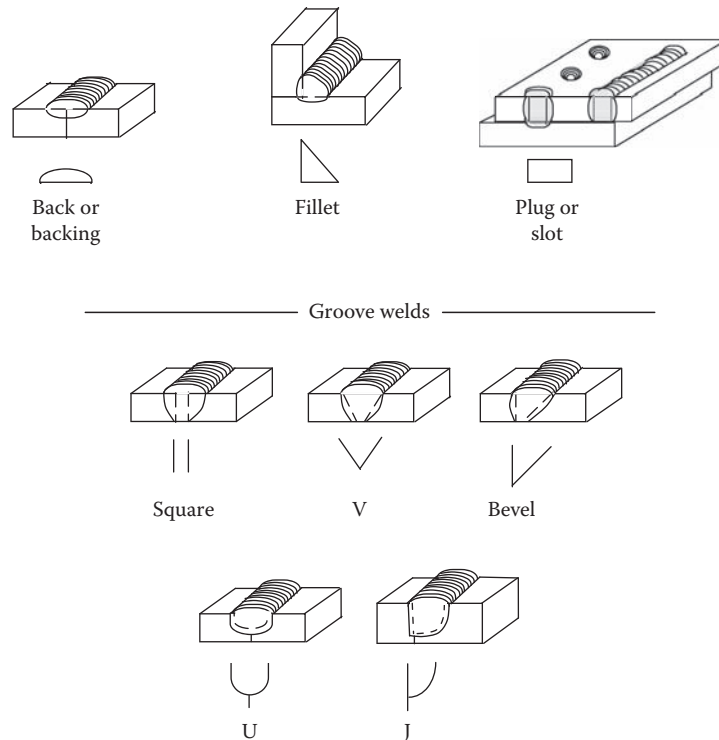

Figure 3.69 Arc and gas welds and symbols.

3.8.3 Basic Weld Symbols

It is important to point out that the term *welding symbol* and *weld symbol* are different. The welding symbol consists of several elements that provide instructions to the welder. The weld symbol, on the other hand, indicates the type of weld only. In the following sections, we describe weld symbols.

3.8.3.1 Symbols for Arc and Gas Welds

The most commonly used arc and gas welds for fusing parts are shown in Figure 3.69. The four types of arc and gas welds are the *back or backing*, the *fillet*, the *plug or slot*, and the *groove*. Groove welds are further classified as square, V, bevel, U, and J (ANSI/AWS, 1991).

3.8.3.2 Symbols for Resistance Welds

In resistance welding, the fusing temperature is produced in the particular area to be welded by applying force and passing electric current between two electrodes and the parts. The four basic resistance welds are the *spot*, *projection*, *seam*, and *flash or upset*. The symbols for general types of resistance welds are given in Figure 3.70.

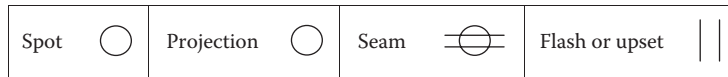

Figure 3.70 Symbols for resistance welds.

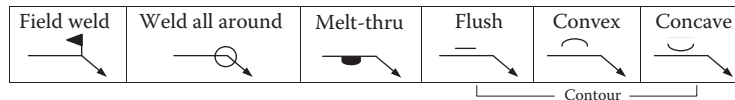

Figure 3.71 Supplementary weld symbols.

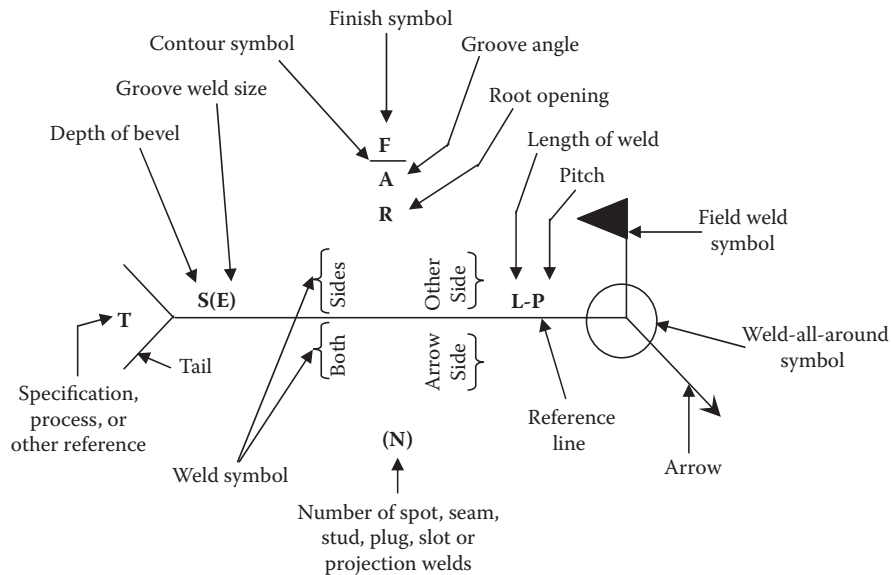

Figure 3.72 Standard welding symbol.

3.8.3.3 Symbols for Supplementary Welds

General supplementary weld symbols are shown in Figure 3.71. These symbols convey additional information about the extent of the welding, the location, and the contour of the weld bead. The contour symbols are placed above or below the weld symbol.

3.8.4 The Welding Symbol

The complete welding symbol (see Figure 3.72) consists of six elements: reference line, arrowhead, weld symbol, dimensions, special symbols, and tail. Each element is described and shown in the following sections.

Note: Although welding symbols are often complex and carry a large amount of data, they may also be quite simple. Maintenance operators should study the various examples that follow and learn to read the symbols.

Figure 3.73 Reference line.

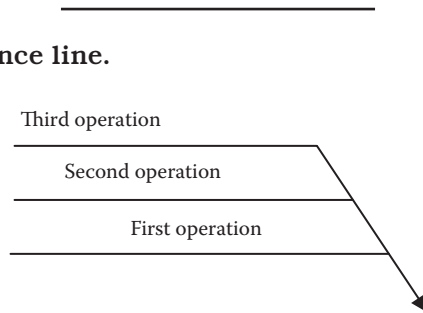

Figure 3.74 List of operations to be performed.

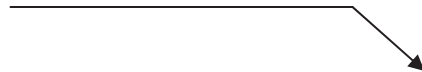

Figure 3.75 Arrowhead.

3.8.4.1 Reference Line

The basis of the welding symbol and all elements shown in Figure 3.73 is the reference line. It is the horizontal line (may appear vertically on some prints) portion of a welding symbol (see Figure 3.72). The reference line contains weld data about size, type, position, length, pitch, and strength. Data can be written or drawn above, below, or on this line. Two or more reference lines may be used to specify steps to be performed in sequence. The first operation to be performed is the one specified on the reference line nearest the arrowhead. Additional operations are specified on subsequent lines as shown in Figure 3.74.

3.8.4.2 Arrowhead

An arrowhead is used to connect the welding symbol reference line to one side of the joint (see Figure 3.75). This is considered the arrow side of the joint (the surface that is in direct line of vision). The side opposite the arrow is considered the other side of the joint; that is, this side is the opposite surface of the joint (see Figure 3.76).

Note: A straight arrow pointing to a joint with a *chamfer* (shaped edge-groove) indicates that the chamfer is to be cut on both pieces. A broken arrow indicates that the chamfer is to be cut only on the piece that the arrow points toward. Two or more arrows from a single reference line indicate multiple locations for identical welds.

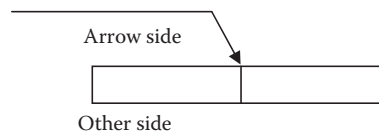

Figure 3.76 Arrowhead showing arrow side and other side.

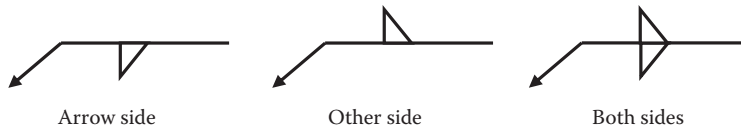

Figure 3.77 Location of welds.

Square butt		Bevel		Fillet		J-groove		V-groove		U-groove	
-------------	--	-------	--	--------	--	----------	--	----------	--	----------	--

Figure 3.78 Weld symbols.

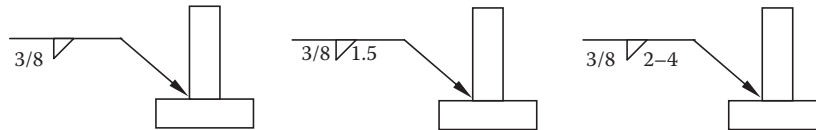

Figure 3.79 Dimensions.

3.8.4.3 Weld Symbol

The weld symbol is attached to the reference line to show the kind of weld and the sides to be welded. The location of a weld is indicated by its placement on the reference line (see Figure 3.77). Weld symbols placed on the side of the reference line nearest the reader indicate welds on the arrow side of the joint. Weld symbols on the reference line side away from the reader indicate welds on the other side of the joint. Weld symbols on both sides of the reference line indicate welds on both sides of the joint. The symbols for some of the most common welds are shown in Figure 3.78.

3.8.4.4 Dimensions

Dimensions of welds are shown on the same side of the reference line as the weld symbol (see Figure 3.79). Dimensions of the chamfer and the weld cross-section are written to the left of the weld symbol. The welding symbol at the right indicates that the fillet weld should be 3/8 inch high by 3/8 inch wide. Length dimensions are written to the right of the weld symbol. The welding symbol at the right indicates that the fillet weld should be 1.5 inches long. If an intermittent weld is required, the center-to-center spacing of the welds follows a hyphen after the length dimension. The welding symbol at the right indicates a series of 2-inch fillet welds 4 inches apart, measured center-to-center.

3.8.4.5 Special Symbols

Special symbols are used with the welding symbols to further specify the type of weld. These special symbols include contour, groove angle, spot welds, weld-all-around, field weld, melt-thru, and finish symbol.

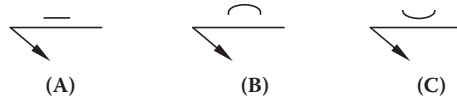

Figure 3.80 Contour symbols.

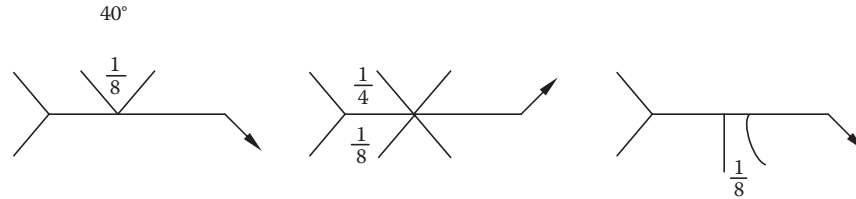

Figure 3.81 Groove angles.

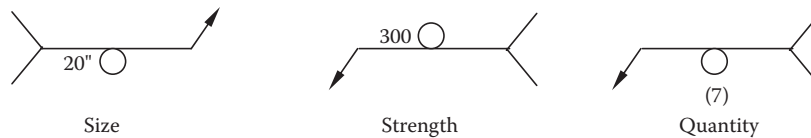

Figure 3.82 Spot weld symbols.

3.8.4.6 Contour Symbol

As shown in Figure 3.80, the contour symbol is placed next to the weld symbol to indicate fillet welds that are to be flush (A), concave (B), or convex (C).

3.8.4.7 Groove Angle

A groove angle is shown on the same side of the reference line as the weld symbol. The size (depth) of groove welds is shown to the left of the weld symbol. The root opening of groove weld is shown inside the weld symbol (see Figure 3.81).

3.8.4.8 Spot Welds

Spot welds are dimensioned either by size or strength (see Figure 3.82). Size is designated as the diameter of the weld expressed in fractions, decimals, or millimeters and is placed to the left of the symbol. The strength, also placed to the left of the symbol, expresses the required minimum shear strength in pounds per spot. If a joint requires a certain number of spot welds, the number is given in parentheses above or below the symbol.

3.8.4.9 Weld-All-Around

When a weld is to extend completely around a joint, a small circle, the weld-all-around symbol, is placed where the arrow connects the reference line (see Figure 3.83).

3.8.4.10 Field Weld

The field weld symbol is used when welds are not to be made in the shop or at the place of initial construction. They are shown by a darkened triangular flag at the juncture of the reference line and arrow. The flag always points toward the tail of the arrow (see Figure 3.84).

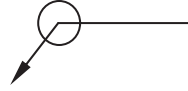

Figure 3.83 Weld-all-around symbol.

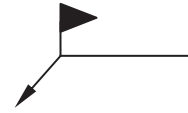

Figure 3.84 Field weld symbol.

3.8.4.11 Melt-Thru Welds

The melt-thru symbol indicates the welds where 100% joint or member penetration plus reinforcement are required in welds made from one side (see Figure 3.85). No dimension of melt-thru, except height of reinforcement, is shown on the weld symbol.



Figure 3.85 Melt-thru symbol.

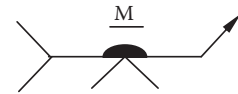

Figure 3.86 Finish symbol (M stands for machining).

3.8.4.12 Finish Symbols

Welds that will be mechanically finished carry a finish symbol (C, chipping; G, grinding; M, machining; R, rolling; H, hammering), along with the contour symbols (see Figure 3.86).

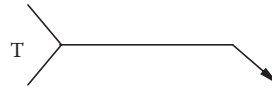

Figure 3.87 Tail symbol.

3.8.4.13 Tail

A tail may be added to the reference line to provide additional welding process information or specifications that are not otherwise shown by symbols (see Figure 3.87). This information is often in the form of symbols or abbreviations.

Note: Standard symbols and abbreviations and suffixes for optional use in applying welding and allied processes are given in tables provided by the American Welding Society.

3.9 ELECTRICITY AND ELECTRICAL DRAWINGS

Working drawings for the fabrication and troubleshooting of electrical machinery, switching devices, chassis for electronic equipment, cabinets, housings, and other mechanical elements associated with electrical equipment are based on the same principles given earlier.















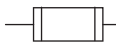







Ceiling fixture 	Motor 	Motor controller 	Wall fixture 
Fuse 	Ground 	Power transformer 	Transformer 
Circuit breaker  S _{CB}	Single-receptacle floor outlet (ungrounded)  UNG	Branch circuit concealed in ceiling or wall 	
Panel board and cabinet 	Branch circuit concealed in floor 	Branch circuit exposed 	
Power panel 	Normally closed contacts 	Three-way switch  S ₃	
Street light 	Normally open contacts 	Single-pole switch  S	
Feeders (note heavy line) 	Number of wires in conduit (3) 	Duplex outlet (grounded) 	

Figure 3.88 Common electrical symbols.

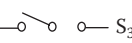
To operate, maintain, and repair electrical equipment in the plant, the wastewater operator (qualified in electrical work) must understand electrical systems. The electrical maintenance operator must be able to read electrical drawings and determine what is wrong when electrical equipment fails to run properly. This section discusses electrical drawings, the functions of important electrical components, and how they are shown on drawings.

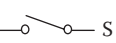
3.9.1 Troubleshooting and Electrical Drawings

A wastewater maintenance operator who is qualified to perform electrical work is often assigned to repair or replace components of an electrical system. To repair anything, the first thing that must be done is to find the problem. The operator may solve the problem by simply restoring electrical power (i.e., resetting a circuit breaker or replacing a fuse). At other times, however, a good deal of troubleshooting may be required. Troubleshooting is like detective work: Find the culprit (the problem or what happened) and remedy (fix) the situation. Troubleshooting is a skill, but even the best troubleshooter would have some difficulty in troubleshooting many complex electrical machines without the proper electrical blueprint or wiring diagram.

3.9.2 Electrical Symbols

Figure 3.88 shows some of the most common symbols used on electrical drawings. It is not necessary to memorize these symbols, but the maintenance operator should be familiar with them and be able to recognize them as an aid to reading electrical drawings.

3.9.3 Electrical Voltage and Power

Because of the force of its electrostatic field, an electric charge has the ability to do the work of moving another charge by attraction or repulsion. The force that causes free electrons (electricity) to move in a conductor as electric current may be referred to as follows:

- Electromotive force (emf)
- Difference in potential
- Voltage

3.9.3.1 What Is Voltage?

When a difference in potential exists between two charged bodies that are connected by a wire (conductor), electrons (current) will flow along the conductor. This flow is from the negatively charged body to the positively charged body until the two charges are equalized and the potential difference no longer exists.

Note: The basic unit of potential difference is the volt (V). The symbol for voltage is V, indicating the ability to do the work of forcing electrons (current flow) to move. Because the volt unit is used, potential difference is called *voltage*.

3.9.3.2 How Is Voltage Produced?

Voltage may be produced in many ways, but some methods are used much more widely than others. The following is a list of the six most common methods for producing voltage:

Friction—Voltage produced by rubbing two materials together

Pressure—Voltage produced by squeezing the crystals of certain substances

Heat—Voltage produced by heating the joint (junction) where two unlike metals are joined

Light—Voltage produced by light striking photosensitive substances

Chemical action—Voltage produced by chemical reaction in a battery cell

Magnetism—Voltage produced in a conductor when the conductor moves through a magnetic field or a magnetic field moves through the conductor in such a manner as to cut the magnetic lines of force of the field

3.9.3.3 How Is Electricity Delivered to the Plant?

Electricity is delivered to the plant from a generating station. The electricity travels to the plant over high-voltage wires. It is important to point out that it is not the voltage *per se* that travels through the wires; instead, current travels through the wires to the plant. Voltage is the

pressure or driving force that pushes the current through the wires. This high-voltage electricity must be reduced to a much lower voltage before it can be used to operate most plant electrical equipment. *Transformers* reduce the voltage. Again, it is *current* that actually flows through the wire. Current is measured in units called *amps* or *amperes*.

3.9.3.4 Electric Power

Power, whether electrical or mechanical, pertains to the rate at which work is being done. The electrical power consumption in a plant is related to current flow.

Key Point: Power is the rate at which work is done.

A large electric pump motor consumes more power (and draws more current, particularly for motors at start) in a given length of time than, for example, an low power using indicating light on a motor controller. *Work* is done whenever a force causes motion. If a mechanical force is used to lift or move a weight, work is done; however, force exerted *without* causing motion, such as the force of a compressed spring acting between two fixed objects, does not constitute work. Electric power is measured in *watts*. One watt is a current of one ampere flowing at a voltage of one volt. To determine watts or wattage, we multiply the current (in amps) by the voltage (in volts).

Note: In a transformer, the number of watts coming in equals the number of watts going out.

3.9.4 Types of Electrical Drawings

Electrical drawings used for troubleshooting in wastewater treatment plant operations include *architectural drawings*, *circuit drawings*, and *ladder drawing*. An architectural drawing shows the physical locations of the electric lines in a plant building or between buildings. A circuit drawing shows the electrical loads served by each circuit.

Note: A circuit drawing does not indicate the physical location of any load or circuit.

3.9.4.1 Architectural Drawings

Figure 3.89 shows three types of architectural drawings. The *plot plan* shows the electric distribution to all of the plant buildings. The *floor plan* shows where branch circuits are located in one building or pumping station, where equipment is located, and where outside and inside tie-ins to water, heat, and electric power are located. The *riser diagram* shows how the wiring runs to each floor of the building.

3.9.4.2 Circuit Drawings

A *circuit drawing* shows how a single circuit distributes electricity to various loads (e.g., pump motors, grinders, bar screens, mixers). Unlike an architectural drawing, a circuit drawing does not show the

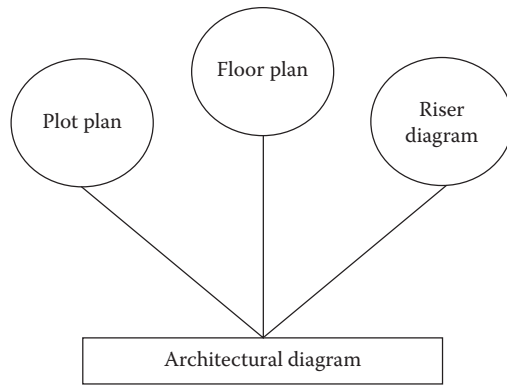

Figure 3.89 Types of architectural diagrams.

location of these loads. Figure 3.90 depicts a typical single-line circuit drawing which shows the power distribution to 11 loads. The number in each circle indicates the power rating of the loads in horsepower. The numbers in the rectangles show the current ratings of circuit breakers. The upper number is the current in amps that the circuit breaker will allow as a momentary surge. The lower number is the maximum current the circuit breaker will allow to flow continuously.

Note: Electrical loads in all plants can be divided into two categories: critical and noncritical. Critical loads are those that are essential to the operation of the plant and cannot be turned off (e.g., critical unit

Note:
All feeder ratings conform to current NEC requirements.

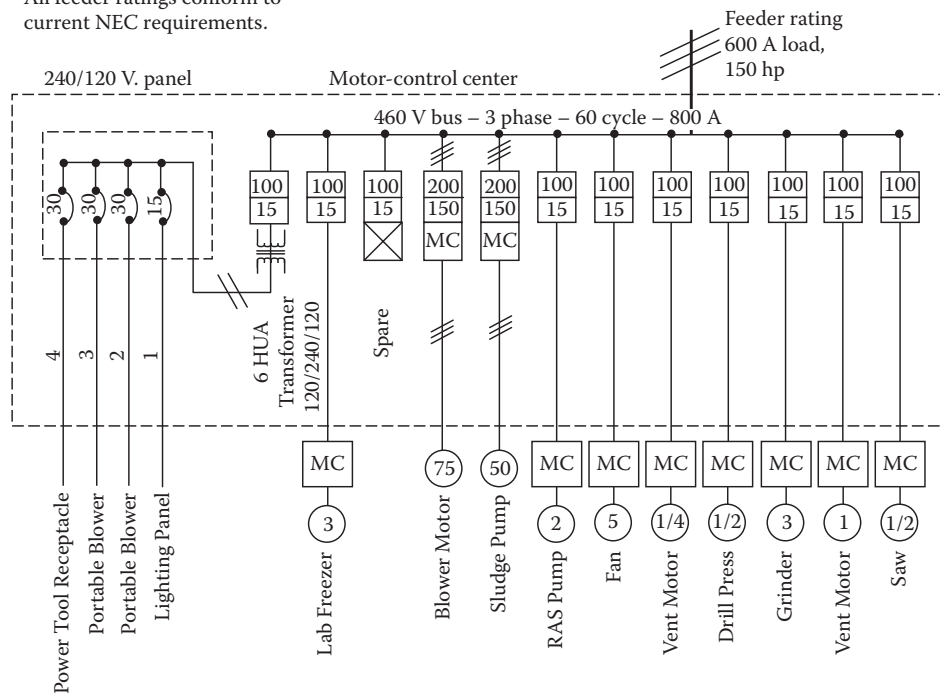

Figure 3.90 Single-line circuit diagram.

processes). Noncritical loads include those pieces of equipment that would not disrupt the operation of the plant or pumping station or compromise safety if they were turned off for a short period of time (e.g., air conditioners, fan systems, electric water heaters, and certain lighting systems).

Note: Circuit breakers are typically equipped with surge protection for three-phase motors and other devices. When a three-phase motor is started, current demand is six to ten times normal value. After start, current flow decreases to its normal rated value. Surge protection is also provided to allow slight increases in current flow when the load varies or increases slightly. Most circuit breakers are also equipped with an instantaneous trip for protection against short circuits.

3.9.4.3 Ladder Drawing

A ladder drawing is a type of schematic diagram that shows a control circuit. The parts of the control circuit lie on horizontal lines, like the rungs of a ladder. Figure 3.91 is an example of a ladder diagram.

Note: The size of electrical drawings is important. This can be understood first in the problem of storing drawings. If every size and shape were allowed, the task of systematic and protective filing of drawings could be tremendous. Pages that are 8-1/2 × 11 or 9 × 12 inches and multiples thereof are generally accepted. The drawing size can also be a problem for the troubleshooter or maintenance operator. If the drawing is too large, it is unwieldy to handle at the machine. If it is too small, it is difficult to read the schematic.

The purpose of a ladder drawing, such as the one shown in Figure 3.91, is to cut maintenance and troubleshooting time. This is accomplished when the designer uses certain guidelines in making electrical drawings and layouts. Let's take a closer look at ladder drawing for the control circuit shown in Figure 3.91. Note the numbering of elementary circuit lines. Normally, closed contacts are indicated by a bar under the line number. Moreover, note that the line numbers are enclosed in a geometric figure to prevent mistaking the line numbers for circuit numbers.

All contacts and the conductors connected to them are properly numbered. Typically, numbering is carried throughout the entire electrical system. This may involve going through one or more terminal blocks. The incoming and outgoing conductors as well as the terminal blocks carry the proper electrical circuit numbers. When possible, connections to all electrical components are taken back to one common checkpoint.

All electrical elements on a machine should be correctly identified with the same markings as shown in the ladder drawing in Figure 3.91; for example, if a given solenoid is marked "solenoid A2" on the drawing, the actual solenoid on the machine should carry the marking "solenoid A2."

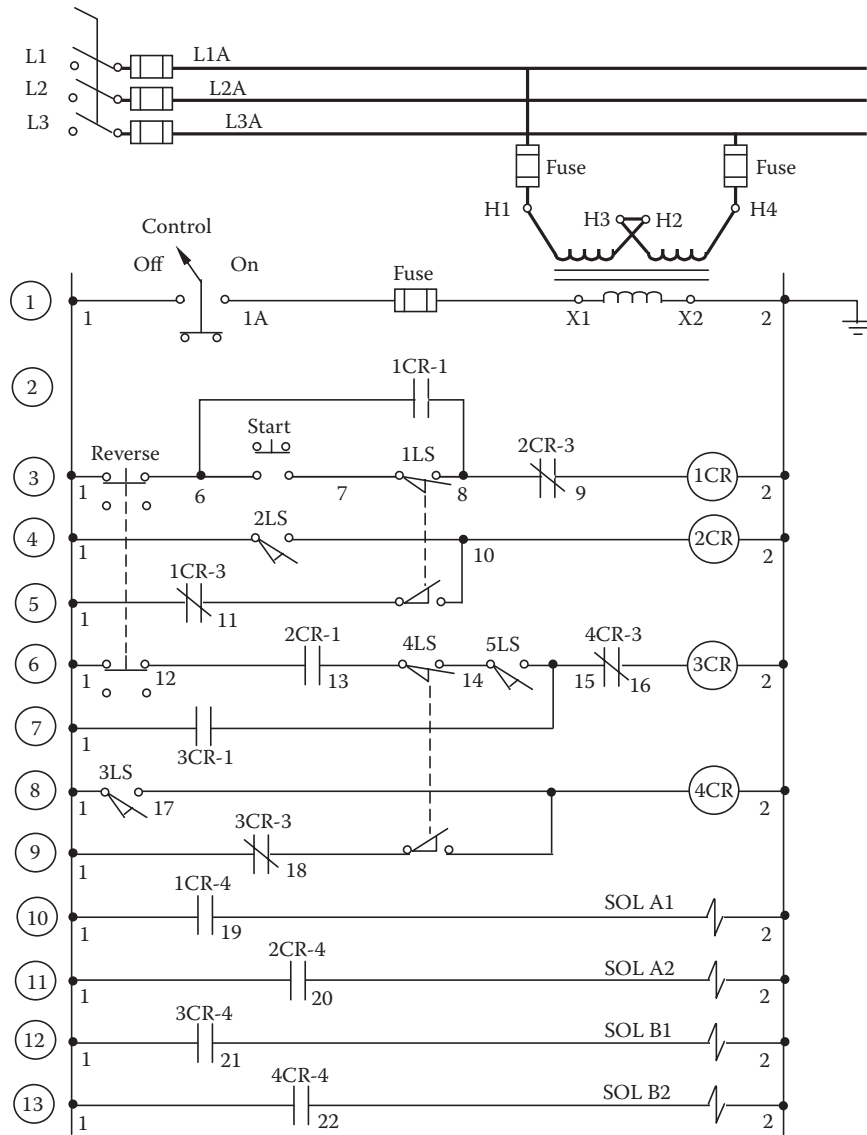

Figure 3.91 Typical ladder drawing.

The bottom line: An electrical drawing is made to show the relative location of each electrical component on the machine. The drawing is not normally drawn to scale, and it need not be; however, usually it is reasonably accurate in showing the location of parts relative to each other and in relative size.

3.10 REFRIGERATION AND AIR CONDITIONING DRAWINGS

In the not too distant past, central indoor climate control was reserved for a limited, privileged few. Today, central cooling in industrial plants is common in some locations. Although repairs often require the expertise of a trained specialist, wastewater maintenance operators

may occasionally be required to perform certain maintenance operations on plant air conditioning and refrigeration systems. To perform certain kinds of service, maintenance operators need to understand the basic parts of AC&R systems. To properly troubleshoot these systems, maintenance operators must also be able to read basic AC&R drawings. Because almost all air conditioning systems must cool the air inside a plant, the system must include refrigeration equipment. It logically follows, therefore, that to understand air conditioning we must first understand the principles of refrigeration.

3.10.1 Refrigeration

Refrigeration is the process of removing heat from an enclosed space or from a substance to lower the temperature. Before mechanical refrigeration systems were introduced, people cooled their food with ice transported from the mountains. Stored ice was the principal means of refrigeration until the beginning of the 20th century, and it is still used in some areas today. Cooling caused by the rapid expansion of gases is the primary means of refrigeration today.

3.10.1.1 Basic Principles of Refrigeration

The basic principles of refrigeration are based on a few natural scientific facts; for example, it is a scientific (and often observed) fact that heat flows naturally from warm substances to cooler substances. For the heat to flow, it is only necessary that the substances have different temperatures and that they make contact with one another. As the heat flows from one substance to the other, the temperature of the warmer substance falls and the temperature of the cooler substance rises. The flow of heat continues until the two substances become equal in temperature. The purpose of a refrigeration system is obvious: to reverse the natural flow of heat. The refrigeration system moves heat from a cool substance and delivers it to a warmer substance. In doing so, the temperature of the cooler substance falls, and the temperature of the warmer substance rises. The refrigeration system reverses heat flow by means of a circulating fluid. The fluid may be either a liquid or a gas, or it may change back and forth from one form to the other. If it is always a liquid or always a gas, the fluid is a *coolant*. If it changes back and forth, it is a *refrigerant*.

Refrigerants are the working fluid of air conditioning and refrigeration systems. Their purpose is to absorb heat by evaporation in one location, transport it to another location through the application of external work, then release it through condensation. A wide range of commercially available refrigerants is suitable for use in an equally wide range of applications. These refrigerants vary in chemical composition, boiling points, freezing points, critical temperatures, flammability, toxicity, chemical stability, chemical reactivity, and cost.

Note: Selection of a particular refrigerant depends on the application and characteristics required. In most cases the choice will be a compromise between different properties.

A refrigeration system, where the fluid changes back and forth from liquid to gas and *vice versa*, works in such a way that the circulating fluid has a lower temperature than the cool substance at one point of the circulation. At another point, it has a higher temperature than the warm substance.

The changing temperature of the refrigerant is important because it makes it possible for heat to flow out of the cool substance and into the warm substance. Although we are talking about an artificial cooling process, it is based on a natural heat flow process. The problem is that energy is required to make the system run. The amount of energy (electrical or mechanical) required is greater than the amount of heat energy moved from the cool place to the warm place.

3.10.1.2 Refrigeration System Components

A mechanical refrigeration system is an arrangement of components in a system that puts the theory of gases into practice to provide artificial cooling. To do this, we must provide the following:

- A metered supply of relatively cool liquid under pressure
- A device in the space to be cooled that operates at reduced pressure so when the cool, pressurized liquid enters it will expand, evaporate, and take heat from the space
- A means of repressurizing (compressing) the vapor
- A means of condensing it back into a liquid, removing its superheat, latent heat of vaporization, and some of its sensible heat

3.10.1.3 Refrigeration System Operation

Every mechanical refrigeration system operates at two different pressure levels. The dividing line is shown in Figure 3.92, which is also the type of simple system drawing with which maintenance operators should be familiar. The line passes through the discharge valves of the compressor on one end and through the orifice of the metering device or expansion valve on the other. The high-pressure side of the refrigeration system is comprised of all of the components that operate at or above condensing pressure. These components are the discharge side of the compressor, the condenser, the receiver, and all interconnected tubing up to the metering device or expansion valve. The low-pressure side of a refrigeration system consists of all the components that operate at or below evaporating pressure. These components include the low-pressure side of the expansion valve, the evaporator, and all of the interconnecting tubing up to and including the low side of the compressor. Refrigeration maintenance operators refer to the pressure on the refrigerant low-pressure vapor drawn from the high side discharge pressure as the *head pressure*. On the low side, the pressure compressed by the compressor is referred to as the *suction pressure* or *low-side pressure*.

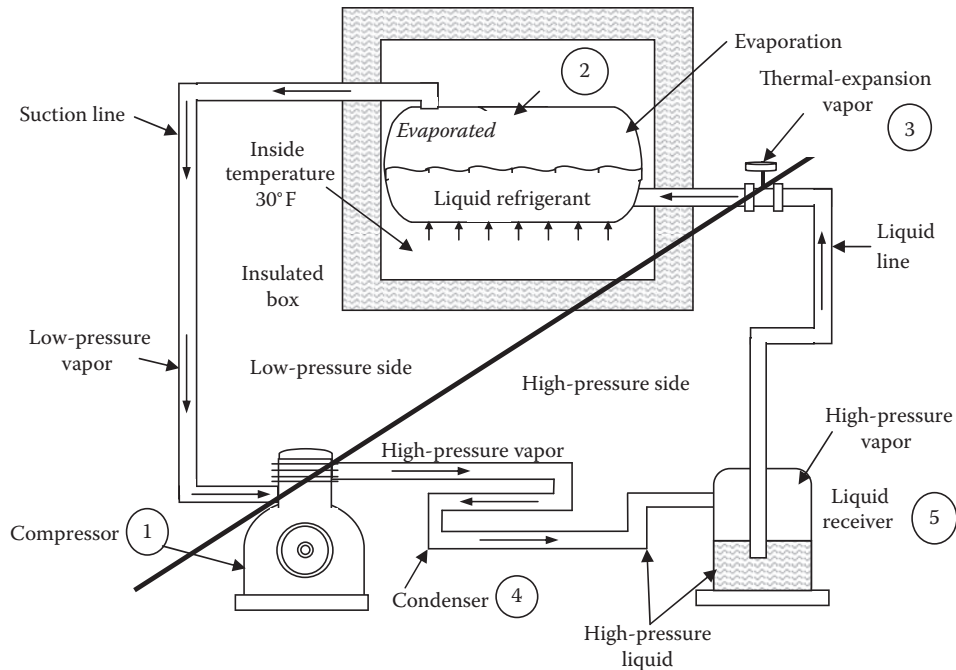

Figure 3.92 Drawing of refrigeration cycle.

3.10.1.4 Using Refrigeration Drawings in Troubleshooting

The maintenance operator would use the basic drawing shown in Figure 3.92 to troubleshoot a typical refrigeration system. Moreover, the troubleshooter, interested in making repairs or adjustments to the system to restore correct operation, obviously needs to understand system operation. In this case, Figure 3.92 is helpful.

Note: The following explanation is rather detailed to provide insight on how valuable system drawings can be in assisting the troubleshooter first to understand system operation and then to determine the cause of the problem. It should be pointed out, however, that this discussion is not designed to make a refrigeration expert out of anyone.

Using Figure 3.92, the maintenance operator can gain complete understanding of the refrigeration cycle of such a mechanical refrigeration system. For example, from Figure 3.92 it can be seen that the pumping action of the compressor (1) draws vapor from the evaporator (2). This action reduces the pressure in the evaporator, causing the liquid particles to evaporate. As the liquid particles evaporate, the evaporator is cooled. Both the liquid and vapor refrigerant tend to extract heat from the warmer objects in the insulated refrigerator cabinet or room.

The ability of the liquid to absorb heat as it vaporizes is very high in comparison to that of the vapor. As the liquid refrigerant is vaporized, the low-pressure vapor is drawn into the suction line by the suction action of the compressor (1). The evaporation of the liquid refrigerant would soon remove the entire refrigerant from the evaporator if it were

not replaced. The replacement of the liquid refrigerant is usually controlled by a metering device or expansion valve (3). This device acts as a restrictor to the flow of the liquid refrigerant in the liquid line. Its function is to change the high-pressure, subcooled liquid refrigerant to low-pressure, low-temperature liquid particles, which will continue the cycle by absorbing heat.

The refrigerant low-pressure vapor drawn from the evaporator by the compressor through the suction line, in turn, is compressed by the compressor to a high-pressure vapor, which is forced into the condenser (4). In the condenser, the high-pressure vapor condenses to a liquid under high pressure and gives up heat to the condenser. The heat is removed from the condenser by the cooling medium of air or water. The condensed liquid refrigerant is then forced into the liquid receiver (5) and through the liquid line to the expansion valve by pressure created by the compressor, making a complete cycle.

Note: Although the receiver is indicated as part of the refrigeration system in Figure 3.92, it is not a vital component; however, omission of the receiver requires exactly the proper amount of refrigerant in the system. The refrigerant charge in systems without receivers is considered to be critical, as any variations in quantity affect the operating efficiency of the unit.

Caution: The refrigeration cycle of any refrigeration system must be clearly understood by the maintenance operator before attempting to repair the system.

3.10.1.5 Refrigeration Component Drawings

When work is to be accomplished on a refrigeration system, we often refer to drawings of the various components. Whether these drawings are assembly or detail drawings, many of them will look much like the drawings we presented earlier in this text. The evaporator drawing shown in Figure 3.93 is an example of a component drawing. This particular evaporator is made of copper tubing with aluminum fins. It functions to cool the air in an air conditioning duct. Complete evaporator units are equipped with accessories such as air-moving devices and motors. Other accessories usually furnished with such units include filters, heating coils, electric resistance or gas heaters, air-humidifying devices, and sheet-metal enclosures. Usually, enclosures are insulated and equipped with inlet and outlet connections for ducts.

3.10.2 Air Conditioning

Air conditioning requires the control of temperature, humidity, purity, and motion of air in an enclosed space, independent of outside conditions. The air conditioning system may be required to heat, cool, humidify, dehumidify, filter, distribute, and deodorize the air.

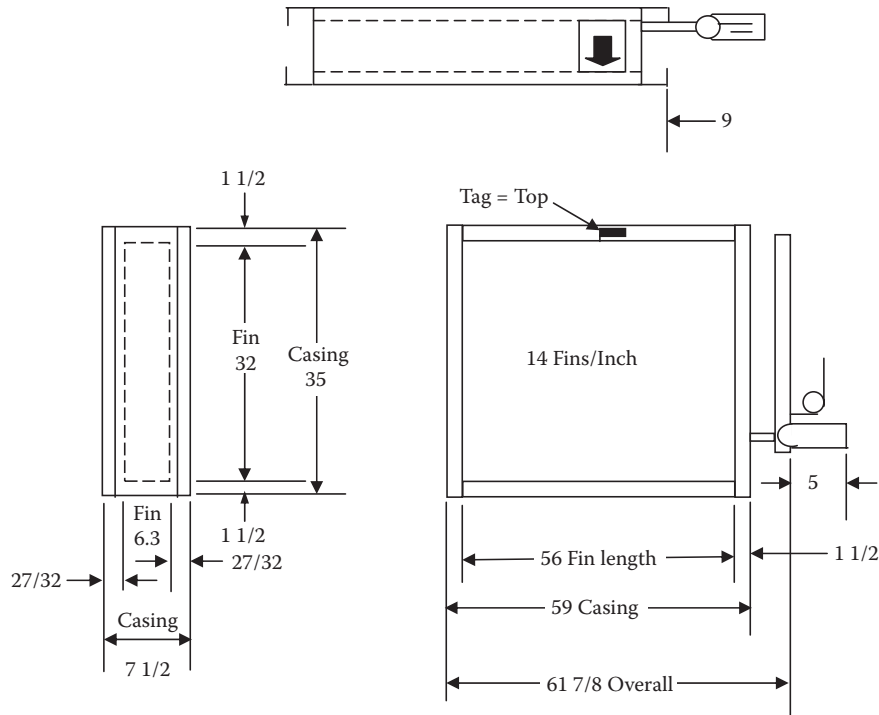

Figure 3.93 Evaporator assembly.

3.10.2.1 Operation of a Simple Air Conditioning System

In a simple air conditioner, the refrigerant, in a volatile liquid form, is passed through a set of evaporator coils across which air inside the room is passed. The refrigerant evaporates and, in the process, absorbs the heat contained in the air. When the cooled air reaches its saturation point, its moisture content condenses on fins placed over the coils. The water runs down the fins and drains. The cooled and dehumidified air is returned into the room by means of a blower. In the meantime, the vaporized refrigerant passes into a compressor where it is pressurized and forced through condenser coils, which are in contact with outside air. Under these conditions, the refrigerant condenses back into a liquid form and gives off the heat it absorbed inside. This heated air is expelled to the outside, and the liquid recirculates to the evaporator coils to continue the cooling process. In some units, the two sets of coils can reverse functions, so in winter the inside coils condense the refrigerant and heat rather than cool the room. Such a unit is known as a *heat pump*. Alternative systems of cooling include the use of chilled water. Water may be cooled by refrigerant at a central location and run through coils throughout the system.

3.10.2.2 Design of Air Conditioning Systems

The design of air conditioning systems takes many circumstances into consideration. A self-contained unit, described above, serves a space directly. More complex systems, as in tall buildings, use ducts to

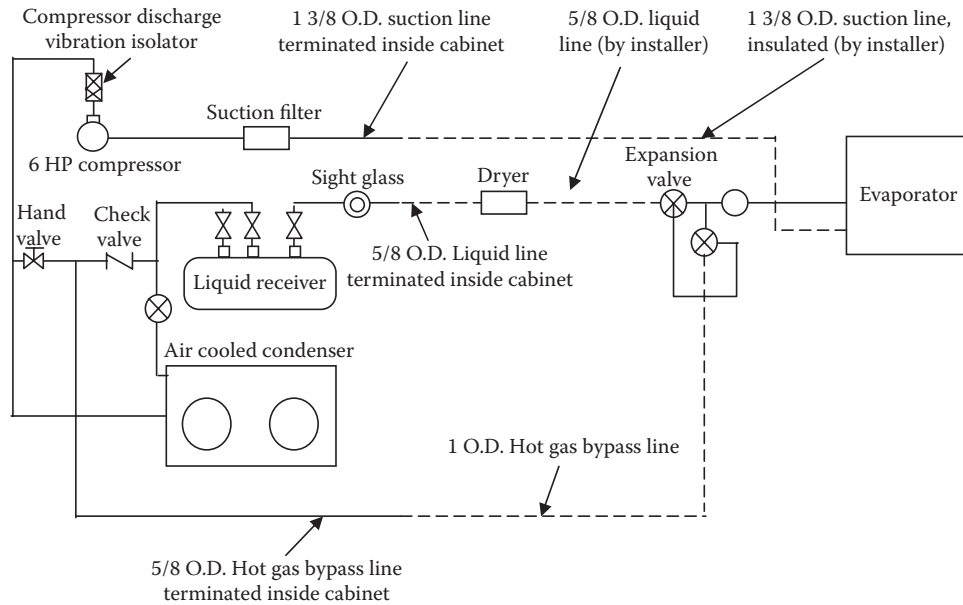

Figure 3.94 Refrigerant piping drawing.

deliver cooled air. In the *induction system*, air is cooled once at a central plant and then conveyed to individual units, where water is used to adjust the air temperature according to such variables as sunlight exposure and shade. In the *duct-duct system*, warm air and cool air travel through separate ducts and are mixed to reach a desired temperature. A simpler way to control temperature is to regulate the amount of cold air supplied, cutting it off once a desired temperature is reached. This method, known as *variable air volume*, is widely used in both high-rise and low-rise commercial or institutional buildings.

3.10.2.3 Air Conditioning Drawings

Drawings for air conditioning systems usually include the following: the entire system; complete central air conditioning installations; two-, three-, and four-pipe systems; controls; water piping; ductwork; cooling towers; various air conditioning components; and refrigerant piping. Figure 3.94 is an example of a refrigerant piping drawing. The purpose of this drawing is to guide the installer on how to make the proper connections in the refrigerant piping. This single-line drawing is, obviously, also helpful in troubleshooting the refrigerant system (e.g., finding a leak). The drawing clearly depicts the identity of the basic parts of the refrigeration system.

3.11 SCHEMATICS AND SYMBOLS

Because of the complexity of many electrical and mechanical systems, it would be almost impossible to show these systems in full-scale detailed drawing. Instead, we use symbols and connecting lines

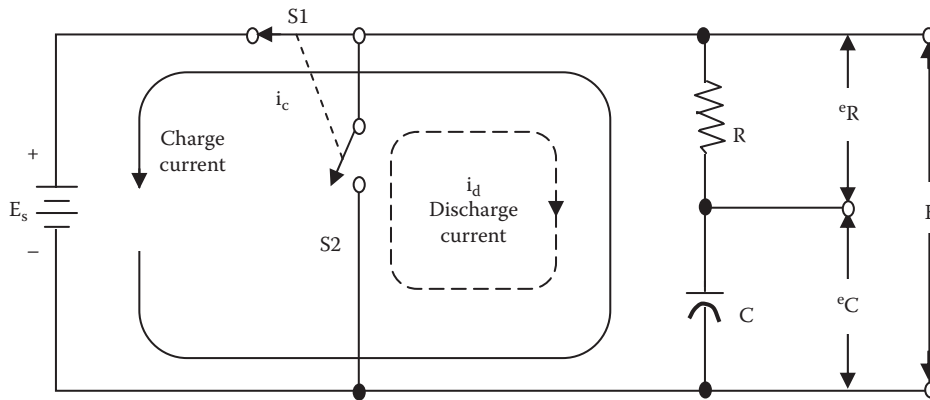

Figure 3.95 Schematic of an RC series circuit.

to represent the parts of a system. Figure 3.95 shows a voltage divider containing resistance and capacitance connected in a circuit by means of a switch. Such a series arrangement is an *RC series circuit*. Note that, unless the reader is an electrician or electronics technician, it is not important to understand this circuit; however, it is important for the reader to understand that Figure 3.95 depicts a schematic representation formed by the use of symbols and connecting lines for a technical purpose.

Note: A schematic is a line drawing made for a technical purpose that uses symbols and connecting lines to show how a system operates.

3.11.1 How to Use Schematic Diagrams

Learning to read and to use a schematic diagram (any schematic diagram) is a little bit like map reading. In a schematic for an electrical circuit, for example, we need to know which wires connect to which component and where each wire starts and finishes. With a map book, this would be equivalent to knowing the origin and destination points and which roads connect to the highway network.

Schematics, however, are a little more complicated, as components need to be identified and some are polarity conscious (must be wired up in the circuit the correct way) in order to work. The reader does not need to understand what the circuit does or how it works to read the drawing, but the reader does need to correctly interpret the schematic. Here are some basic rules that will help with reading a simple diagram.

In Figure 3.96, the heavy lines represent wires; for simplicity, we have labeled them as A, B, and C. There are just three components here and it is easy to see where each wire starts and ends, and which components a wire is connected to. As long as the wire labeled A connects to the switch and negative terminal of the battery, wire B connects to the switch and lamp, and C connects to the lamp and the positive battery terminal then this circuit should operate.

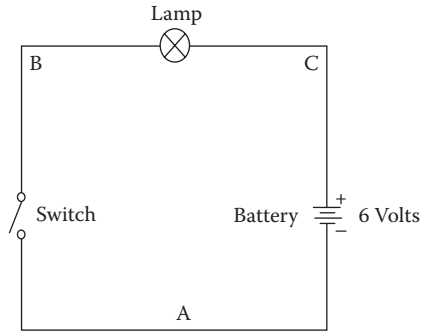

Figure 3.96 A single schematic diagram.

Before we move on and describe how to read the diagram, it is important to point out that any schematic may be drawn in a number of different ways; for example, in Figure 3.97 and Figure 3.98 we have drawn two electrically equivalent lamp dimmer circuits. They may look very different, but if we mentally label the wires and trace them, we will see that in both diagrams each wire starts and finishes at the same components on both diagrams. The components have been labeled and so the three terminals of the transistor (e.g., NPN is the transistor).

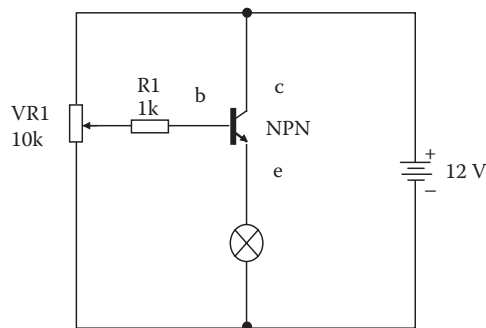

Figure 3.97 Schematic of a simple lamp dimmer circuit.

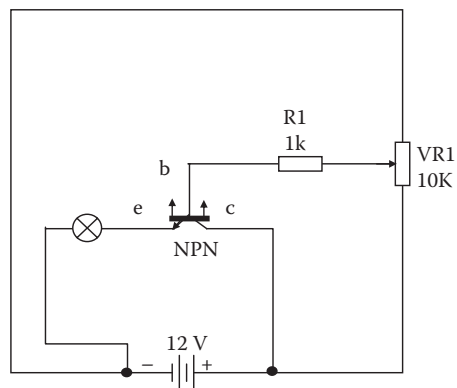

Figure 3.98 Schematic of a simple lamp dimmer circuit.

In Figure 3.98, the two wire junctions are indicated by a dot. A wire connects from the positive battery terminal to the C (transistor collector) terminal, and a wire runs from the collector terminal to one end of the potentiometer (VR1). The wires could be joined at the transistor collector, positive battery terminal, or even one end of the potentiometer; it does not matter, as long as both wires exist. Similarly, a wire runs from the negative battery terminal to the lamp and from the lamp to the other end of VR1. The wires could be joined at the negative terminal of the battery, the lamp, or the opposite leg of VR1. In Figure 3.98, we could have drawn the wires from the lamp and bottom terminal of VR1 back to the negative battery terminal and placed the dot there; it would be the same. Looking at Figure 3.98, we see that one wire junction appears at the negative battery terminal, and the other junction is at a similar place.

3.11.2 Schematic Circuit Layout

Sometimes the way a circuit is wired may compromise its performance. This is particularly true for high-frequency and radio circuits, as well as some high-gain audio circuits. Consider the audio circuit shown in Figure 3.99. (For our purposes here, we have simplified the following explanation.) Although this circuit has a voltage gain of less than one, wires to and from the transistor should be kept as short as possible. This will prevent a long wire from picking up radio interference or hum from a transformer. Moreover, in this circuit, input and output terminals have been labeled, and a common reference point or earth (ground) is indicated. The ground terminal would be connected to the chassis (metal framework of the enclosure) in which the circuit is built. Many schematics contain a chassis or ground point. Generally, it is just to indicate the common reference terminal of the circuit, but in radio work the ground symbol usually requires a physical connection to a cold water pipe or a length of pipe or earth spike buried in the soil.

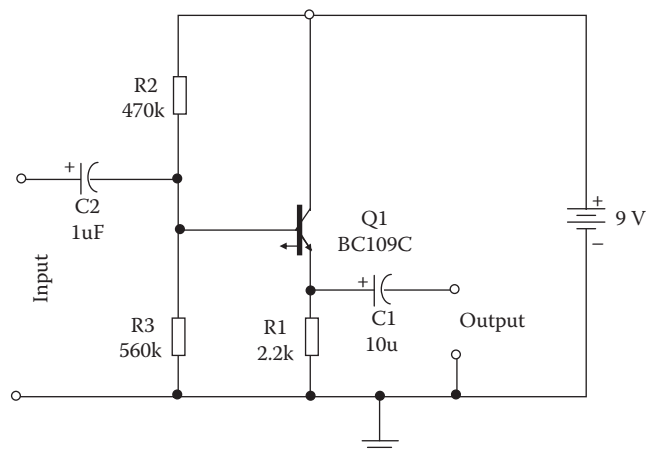

Figure 3.99 Schematic of a simple audio circuit.

3.11.3 Schematic Symbols

Wastewater operators and maintenance operators must be Jacks or Jills of many trades. Simply, a good maintenance operator must be able to do many different kinds of jobs. To become a fully qualified Jack or Jill, the maintenance operator must learn to perform a variety of tasks: electrical, mechanical, piping, fluid power, AC&R, hotwork, and many others. Moreover, maintenance operators must be flexible; they must be able to work on both familiar as well as new equipment and systems. We have all heard seasoned maintenance operator claim that they can fix anything and everything using nothing more than their own intuition (i.e., “seat of the pants” troubleshooting). In the real world, however, to troubleshoot systems, maintenance operators must be able to read and understand schematics. By learning this skill, operators will have little difficulty understanding, maintaining, and repairing almost any equipment or unit process in the plant—old or new.

3.11.3.1 Lines on a Schematic

As mentioned, symbols are used instead of pictures on schematics, and a schematic is simply a line diagram. Lines on a schematic show the connections between the symbols (devices) in a system. Each line has meaning; thus, we can say that schematic lines are part of the symbology employed. The meaning of certain lines, however, depends on the kind of system the schematic portrays; for example, a simple solid line can have totally different meanings. On an electrical diagram, it probably represents wiring. On a fluid-power diagram, it stands for a working line. On a piping diagram, it could mean a low-pressure steam line. Figure 3.100 shows some other common lines used in schematics. A schematic diagram is not necessarily limited to one kind of line. In fact, several kinds of lines may appear on a single schematic. Following applicable ANSI standards, most schematics use only one thickness, but they may use various combinations of solid and broken lines.

Note: Not all schematics adhere to standards set by national organizations as an aid in providing uniform drawings. Some designers prefer to use their own line symbols. These symbols are usually identified in a legend.

3.11.3.2 Lines Connect Symbols

If we look at a diagram filled with lines, we may simply have nothing more than a diagram filled with lines. Likewise, if we look at a diagram with assorted symbols, we may simply have a diagram filled with various symbols. Such diagrams may have meaning to someone but probably have little meaning to most of us. To make a schematic readable (understandable) for a wide audience, we must have a diagram that uses a combination of recognizable lines and symbols. When symbols are combined with lines in schematic form, we must also understand the meaning of the symbols used. The meaning of certain symbols depends

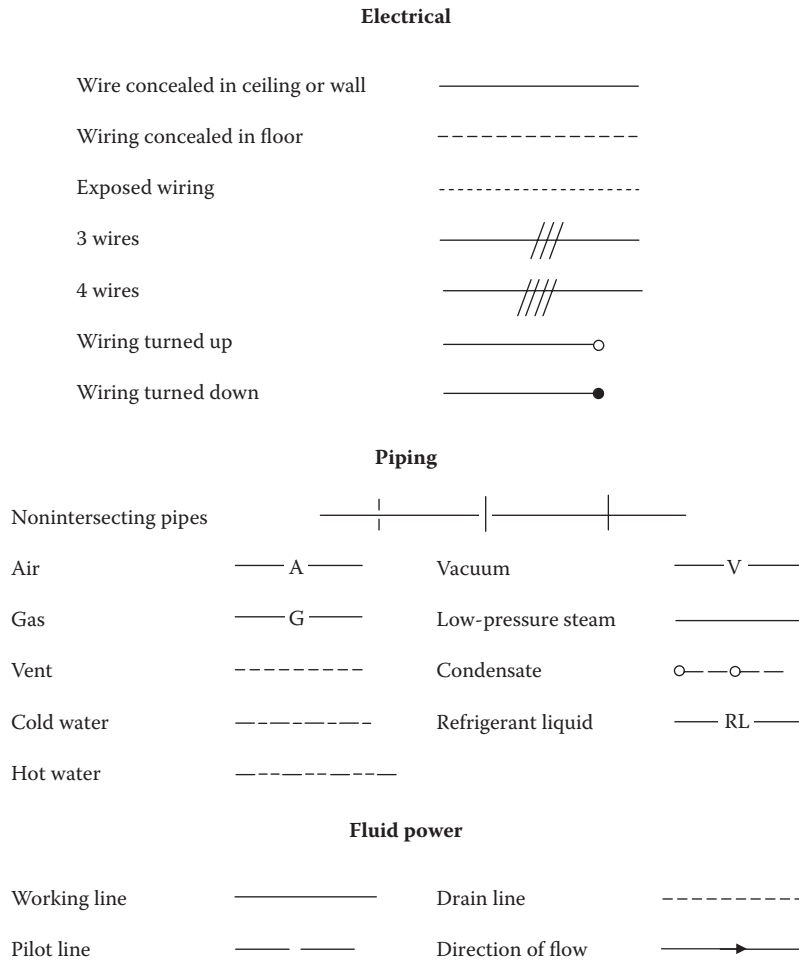

Figure 3.100 Examples of lines used in schematics.

on the kind of system the schematic shows; for example, the symbols used in electrical systems differ from those used in piping and fluid-power systems.

The bottom line: To understand and properly use a schematic diagram, we must understand the meaning of both the lines and the symbols used.

3.11.4 Schematic Diagram: An Example

Figure 3.101 shows a schematic diagram used in electronics and communications (ANSI, 1982). The layout of this schematic involves the same principles and procedures (except for lesser detail) suggested for more complex schematics. Although less complex than most schematics, Figure 3.101 serves our intended purpose: to provide a simplified schematic diagram for basic explanation and easier of understanding of a few key points—essential to understanding schematics and on how to use them.

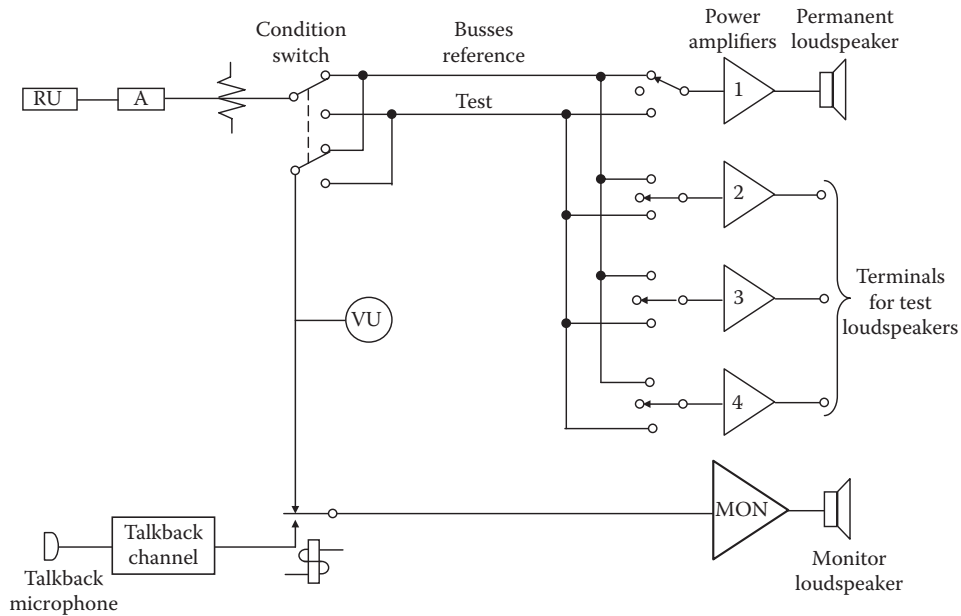

Figure 3.101 Single-line diagram. (From ANSI, *ANSI Y14.15: Dimensioning and Tolerancing*, ANSI, New York, 1982.)

3.11.4.1 A Schematic by Any Other Name Is a Line Diagram

The schematic (or line) diagram is intended to describe the basic functions of a circuit or system. As such, the individual lines connecting the symbols may represent single conductors or multiple conductors. The emphasis is on the function of each stage of a device and the composition of the stage. The various parts or symbols used in a schematic (or line) diagram are typically arranged to provide a pleasing balance between blank areas and lines (see Figure 3.101). Sufficient blank spaces are provided adjacent to symbols for insertion of reference designations and notes.

It is standard practice to arrange schematic and line diagrams so the signal or transmission path from input to output proceeds from left to right (see Figure 3.101) and from top to bottom for a diagram in successive layers. Supplementary circuits, such as a power supply and an oscillator circuit, are usually shown below the main circuit.

Stages of an electronic device, such as shown in Figure 3.101, are groups of components, usually associated with a transistor or other semiconductor, which together perform one function of the device. *Connecting lines* (for conductors) are drawn horizontally or vertically, for the most part, minimizing bends and crossovers. Typically, long interconnecting lines are avoided. Instead, *interrupted paths* are used in place of long, awkward interconnecting lines or where a diagram occupies more than one sheet. When parallel connecting lines are drawn close together, the spacing between lines is not less than .06 inch after reduction. As a further visual aid, parallel lines are grouped with consideration of function, and with double spacing between groups.

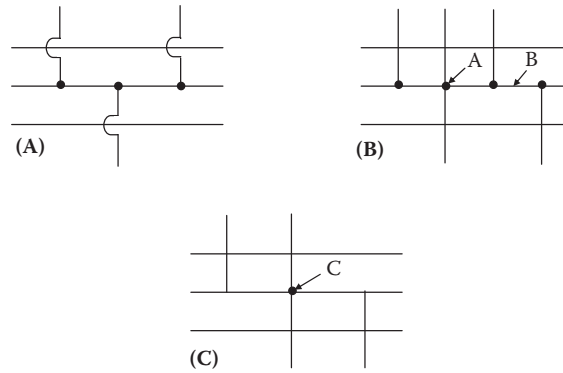

Figure 3.102 Crossovers.

Crossovers are usually necessary in schematic diagrams. The looped crossovers shown in Figure 3.102A have been used for several years to avoid confusion; however, this method is not approved by ANSI. A simpler practice recognized by ANSI is shown in Figure 3.102B. Connection of more than three lines at one point, shown at A, is not recommended and can usually be avoided by moving or staggering one or more lines, as shown at B. ANSI Y14.15 recommends crossovers as shown in Figure 3.102C. In this system, it is understood that termination of a line signifies a connection. If more than three lines come together, as shown at C, the dot symbol becomes necessary. Interrupted paths, either for a single line or groups of lines, may be used where desirable for overall simplification of a diagram.

3.11.5 Schematics and Troubleshooting

One of the primary purposes of schematic diagrams is to assist the maintenance operator in troubleshooting system, component, or unit process faults. A basic schematic can be the troubleshooter's best friend, but experience has shown that many mistakes and false starts can be avoided by taking a step-by-step approach to troubleshooting. Seasoned wastewater maintenance operators usually develop a standard troubleshooting protocol or step-by-step procedure to assist them in their troubleshooting activities. No single protocol is the same; each troubleshooter proceeds based on intuition and experience (not on "seat of the pants" solutions). The simple 15-step protocol described below, however, has worked well (along with an accurate system schematic) for those of us who have used it (note that several steps may occur at the same time):

1. Recognize that a problem exists (figure out what it is designed to do and how it should work).
2. Review all available data.
3. Find the part of the schematic that shows the troubled area, and study it in detail.
4. Evaluate the current plant operation.

5. Decide what additional information is needed.
6. Collect the additional data.
7. Test the process by making modifications and observing the results.
8. Develop an initial opinion as to the cause of the problem and potential solutions.
9. Fine tune your opinion.
10. Develop alternative actions to be taken.
11. Prioritize alternatives (e.g., based on its chances of success, how much it will cost).
12. Confirm your opinion.
13. Implement the alternative actions (this step may be repeated several times).
14. Observe the results of the alternative actions implemented; that is, observe the impact on effluent quality, the impact on individual unit process performance, changes (trends) in the results of process control tests and calculations, and the impact on operational costs.
15. During project completion, evaluate other, more permanent long-term solutions to the problem, such as chemical addition, improved preventive maintenance, or design changes. Continue to monitor results. Document the actions taken and the results produced for use in future problems.

3.12 ELECTRICAL SCHEMATICS

A good deal of the wastewater treatment process equipment in use today runs by electricity. Plants must keep their electrical equipment working. When a machine fails or a system stops working, the plant maintenance operator must find the problem and solve it quickly. No maintenance operator can be expected to remember all the details of the electrical equipment in the plant. This information must be stored in diagrams or drawings in a format that can be readily understood by trained and qualified maintenance operators. Electrical schematics store the information in a user-friendly form. This section discusses the basics of electrical schematics and wiring diagrams. Typical symbols and circuits are used as examples.

When describing electrical systems, three kinds of drawings are typically used: pictorial, wiring, and schematic drawings. *Pictorial drawings* show an object or system much as it would appear in a photograph—as if we were viewing the actual object. Several sides of the object are visible in the one pictorial view. Pictorial drawings are quite easy to understand. They can be used in making or servicing simple objects but are usually not adequate for complicated parts or systems, such as electrical components and systems. A *wiring diagram* shows the connections of an installation or its component devices or parts. It may cover internal or external connections, or both, and contains such









Single wire		Wires crossing but not connected		
Wiring concealed in floor				
Exposed wiring		Wires connected (dot required)		

Figure 3.103 Symbols for wires.

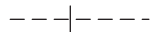
detail as is needed to make or trace connections that are involved. The wiring diagram usually shows the general physical arrangement of the component devices or parts. A *schematic diagram* uses symbols instead of pictures for the working parts of the circuit. These symbols are used in an effort to make the diagrams easier to draw and easier to understand. In this respect, schematic symbols aid the maintenance operator in the same way that shorthand aids the stenographer.

Note: A schematic diagram emphasizes the flow in a system. It shows how a circuit functions, rather than how each part actually looks. Stated differently, a schematic represents the *electrical*, not the physical, situation in a circuit.

3.12.1 Electrical Symbols

Electrical and electronic circuits are indicated by very simple drawings, called *schematic symbols*, which are standardized throughout the world, with minor variations. Some of these symbols look like the components they represent. Some look like key parts of the components they represent. Maintenance operators must know these symbols so they can read the diagrams and keep the plant equipment in working order. The more schematics are used, the easier it becomes to remember what these symbols mean.

3.12.1.1 Schematic Lines

In electrical and electronic schematics, lines symbolize (or stand for) wires connecting various components. Different kinds of lines have different meanings in schematic diagrams. Figure 3.103 shows examples of some lines and their meanings; other lines are usually identified by a diagram legend. To understand any schematic diagram, we must observe how the lines intersect. These intersections show that two or more wires are connected or that the wires pass over or under each other without connecting. Figure 3.103 shows some of the connections and crossings of lines. When wires intersect in a connection, a dot is used to indicate this. If it is clear that the wires connect, the dot is not used.

Note: Wires and how they intersect are important. Maintenance operators must be able to tell the difference between wires that connect and those that do not to be able to properly read the schematic and determine the flow of current in a circuit.

**3.12.1.2 Power Supplies:
Electrical Systems**

Most wastewater treatment facilities receive electrical power from the transmission lines of a utility company. On a schematic, the entry of power lines into the electrical system can be shown in several ways. Electrical power supply lines to a motor are shown in Figure 3.104. Another source of electrical power is a battery. A battery consists of two or more cells. Each cell is a unit that produces electricity by chemical means. The cells can be connected together to produce the necessary voltage and current; for example, a 12-volt storage battery might consist of six 2-volt cells.

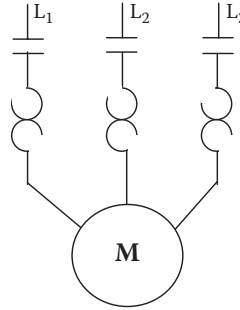

Figure 3.104 Electrical power supply lines.



Figure 3.105 Schematic symbol for a battery.

On a schematic, a battery power supply is represented by a symbol. Consider the symbol in Figure 3.105. The symbol is rather simple and straightforward but is also very important. By convention, the shorter line in the symbol for a battery represents the negative terminal. It is important to remember this, because it is sometimes necessary to note the direction of current flow, which is from negative to positive, when examining a schematic. The battery symbol shown in Figure 3.105 has a single cell, so only one short and one long line are used. The number of lines used to represent a battery vary (and they are not necessarily equivalent to the number of cells), but they are always in pairs, with long and short lines alternating. In the circuit shown in Figure 3.106, the current would flow in a *counterclockwise* direction; that is, in the opposite direction that the hands of a clock move. If the long and short lines of the battery symbol (symbol shown in Figure 3.106) were reversed, the current in the circuit shown in Figure 3.106 would flow *clockwise*—that is, in the direction that the hands of a clock move.

Note: Current flows from the negative (-) terminal of the battery (see Figure 3.107) through the switch, fuse, and resistor (R) to the positive (+) battery terminal, and it continues flowing through the battery from the positive (+) terminal to the negative (-) terminal. As long as the pathway is unbroken, it is a closed circuit, and current will flow; however, if the

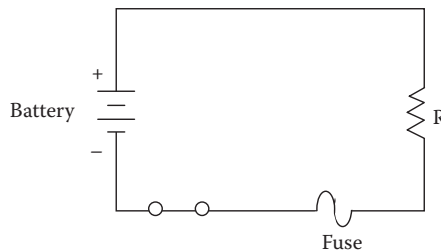

Figure 3.106 Schematic of a simple fused circuit.

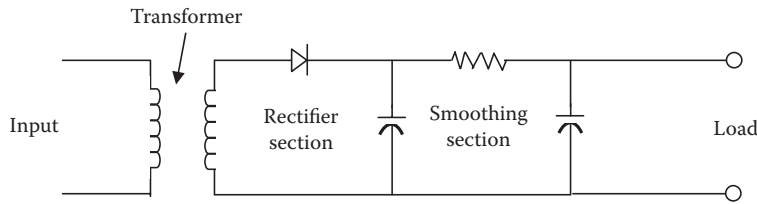

Figure 3.107 Basic power supply.

path is broken (e.g., switch is in the open position), it is an open circuit, and no current flows.

Note: In Figure 3.106, a fuse is placed directly into the circuit. A fuse will open the circuit whenever a dangerous large current starts to flow; a short-circuit condition occurs due to an accidental connection between two points in a circuit offering very little resistance. A fuse will permit currents smaller than the fuse value to flow but will melt and therefore break or open the circuit if a larger current flows.

In wastewater treatment operations, maintenance operators are most likely to maintain or troubleshoot circuits connected to an outside power source. Occasionally, however, they may also work on some circuits that are battery powered. In fact, in work on electronics systems, more work may be performed on battery-power supplied systems than on outside sources. Electronic power supply systems are discussed in the following section.

3.12.1.3 Power Supplies: Electronics

In electronics, power supplies perform two important functions: (1) they provide electrical power when no other source is available, and (2) they convert available power into power that can be used by electronic circuits. Power supplies can be used to provide the DC supply voltage required for an amplifier, oscillator, or other electronic device.

Note: Conversion from one type of power supply (AC to DC, for example) does not improve the quality of the input power, so power conditioners are added for smoothing.

A simple schematic diagram (see Figure 3.107) best demonstrates the actual makeup of an electronic power supply. As shown in the figure, a basic power supply consists of four sections: a transformer, a rectifier, a smoothing section, and a load. The transformer converts the 120-V line AC to a lower AC voltage. The rectifier section is used to convert the AC input to DC. Unfortunately, the DC produced is not smooth DC but instead is pulsating DC. The smoothing, or conditioning, section functions to convert the pulsating DC to pure DC with as little AC ripple as possible. The smoothed DC is then applied to the load.

Electronic components must have electrical power to operate, obviously. This electrical power is usually direct current (in electronic equipment). Components typically use a single low voltage, usually 5 volts,

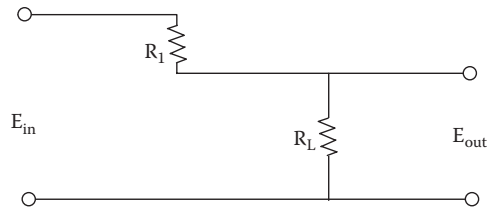

Figure 3.108 Schematic of basic DC-to-DC power supply.

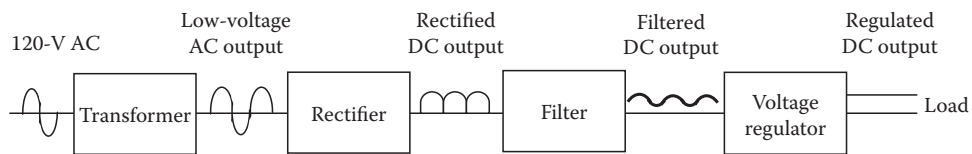

Figure 3.109 Schematic of an AC-to-DC power supply.

and single polarity, either positive (+5 V) or negative (–5 V). Circuits often require several voltages and both polarities, typically +5 V, –5 V, +12 V, and –12 V. One of the simplest power supplies, a DC-to-DC power supply, is shown in schematic form in Figure 3.108. In this simple circuit, if the current drawn by the load does not change, the voltage across the resistor (often referred to as a *dropping resistor*) will be as steady as the source voltage.

In an AC-to-DC power supply, a rectifier changes the 60-hertz AC input voltage to fluctuating, or pulsating, DC output voltage. The diode allows current in only one direction, for one polarity of applied voltage. Thus, current flows in the output circuit only during the half-cycles of the AC input voltage that turn the diode on. Figure 3.109 shows a schematic of a typical AC-to-DC power supply. Notice that the input is 120-V AC, which is typical of the voltage supplied to most households and businesses from a utility line. The 120-V AC is fed to the primary of a transformer. The transformer reduces the voltage of the AC output from the secondary. The transformer output (secondary output) is the input to the rectifier, which delivers a pulsating DC output. The rectified output is the input to the filter, which smoothes out the pulses from the rectifier. The filter output is the input to the voltage regulator, which maintains a constant voltage output, even if the power drawn by the load changes. The voltage regulator output is then fed to the load.

Power smoothers, or conditioners, are built into or added to power supplies to regulate and stabilize the power supply. They include filters and voltage regulators. A *filter* is used in both DC output and AC output power supplies. In DC output power supplies, filters help smooth out the

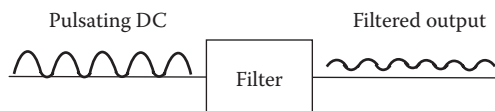

Figure 3.110 Ripple in filter output.

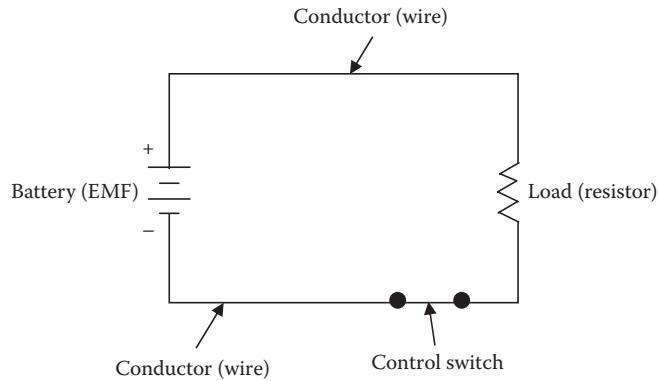

Figure 3.111 Schematic of a simple closed circuit.

rectifier output pulses, as shown in Figure 3.110. In AC output power supplies, filters are used to shape waveforms (i.e., they remove the undesired parts of the waveform).

3.12.1.4 Electrical Loads

An electric circuit, which provides a complete path for electric current, includes an energy (voltage) source, such as a battery or utility line; a conductor (wire); a means of control (switch); and a load. As shown in the schematic representation in Figure 3.111, the energy source is a battery. The battery is connected to the circuit by conductors (wire). The circuit includes a switch for control. The circuit also consists of a load (resistive component). The load that dissipates battery-stored energy could be a lamp, a motor, heater, resistor, or some other device (or devices) that does useful work, such as an electric toaster, a power drill, radio, or soldering iron. Figure 3.112 shows some symbols for common loads and other components in electrical circuits. The maintenance operator should become familiar with these symbols (and others not shown here), because they are widely used.

Note: Every complete electrical circuit has at least one load.

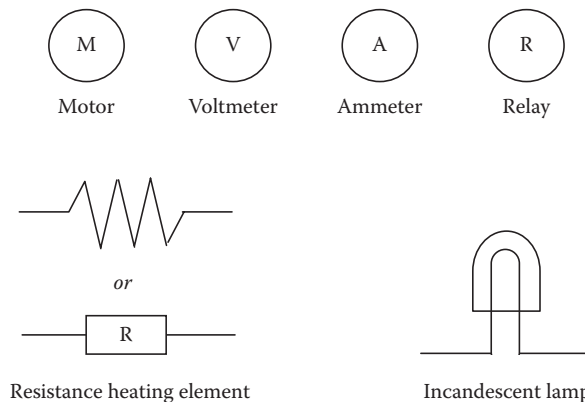

Figure 3.112 Symbols for electrical loads.







Single-pole, single-throw (SPST)	 	Normally open (NO)	
Double-pole, single-throw (DPST)		Normally closed (NC)	
Single-pole, double-throw (SPDT)		Two-position (NC-NO)	
Double-pole, double-throw (DPDT)			

Figure 3.113 Types of switches.

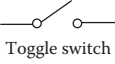
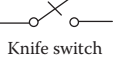
3.12.1.5 Switches

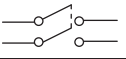
In Figure 3.106 and Figure 3.111, the schematics show simple circuits with switches. A switch is a device for making or breaking the electrical connection at one point in a wire. A switch allows starting, stopping, or changing the direction of current flow in a circuit. Figure 3.113 shows some common switches and their symbols.

3.12.1.6 Inductors (Coils)

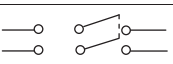
Simply put, an inductor is a coil of wire, usually many turns of wire around a piece of soft iron (magnetic core). In some cases, the wire is wound around a nonconducting material. Inductors are used as ballasts in fluorescent lamps and for magnets and solenoids. When electric current flows through a coil, it creates a magnetic field (an electromagnetic field). The magnetism causes certain effects required in electric circuits (e.g., in an alarm circuit, the magnetic field in a coil can cause the alarm bell to ring). It is not important to understand these effects to be able to read schematic diagrams. It is, however, important to recognize the symbols for inductors (or coils). These symbols are shown in Figure 3.114.

3.12.1.7 Transformers

Transformers are used to increase or decrease AC voltages and currents in circuits. The operation of transformers is based on the principle of *mutual inductance*. A transformer usually consists of two coils of wire wound on the same core. The primary coil is the input coil of the transformer and the secondary coil is the output coil. Mutual induction causes voltage to be induced in the secondary coil. If the output voltage of a transformer is greater than the input voltage, it is a *step-up transformer*. If the output voltage of a transformer is less than the input voltage it is a *step-down transformer*. Figure 3.115 shows some of the basic symbols that are used to designate transformers on schematic diagrams.







Relay coil		Solenoid		Variable coil	 or 
Fixed coil		Tapped coil			

Figure 3.114 Symbols for coils and inductors.

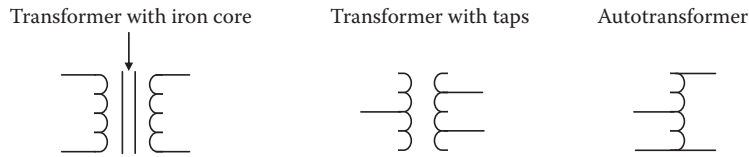

Figure 3.115 Transformer symbols.

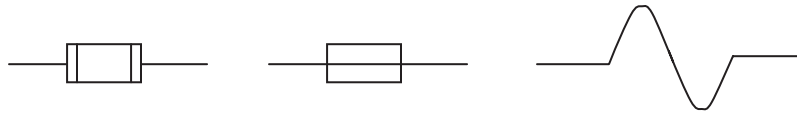

Figure 3.116 Fuse symbols.

3.12.1.8 Fuses

A fuse is a device that automatically opens a circuit when the current rises above a certain limit. When the current becomes too high, part of the fuse melts. Melting opens the electrical path, stopping the flow of electricity. To restore the flow of electricity, the fuse must be replaced. Figure 3.116 shows some of the basic symbols that are used to designate fuses on schematic diagrams.

3.12.1.9 Circuit Breakers

A circuit breaker is an electric device (similar to a switch) that, like a fuse, interrupts an electric current in a circuit when the current becomes too high. The advantage of a circuit breaker is that it can be reset after it has been tripped; a fuse must be replaced after it has been used once. When a current supplies enough energy to operate a trigger device in a breaker, a pair of contacts conducting the current are separated by preloaded springs or some similar mechanism. Generally, a circuit breaker registers the current either by the heating effect of the current or by the magnetism it creates in passing through a small coil. Figure 3.117 shows some of the basic symbols that are used to represent circuit breakers on schematic diagrams.

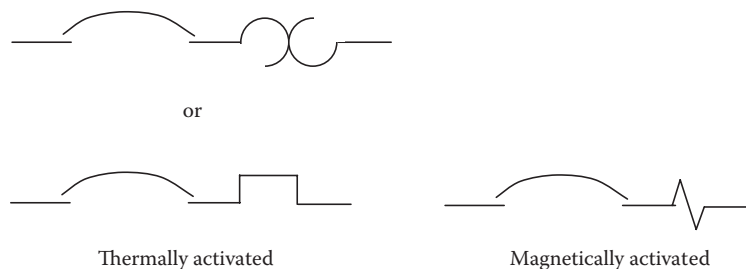

Figure 3.117 Circuit breaker symbols.

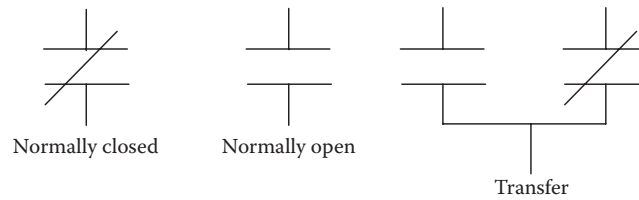

Figure 3.118 Electrical contacts symbols.

3.12.1.10 Electrical Contacts

Electrical contacts (usually wires) join two conductors in an electrical circuit. *Normally closed* (NC) contacts allow current to flow when the switching device is at rest. *Normally open* (NO) contacts prevent current from flowing when the switching device is at rest. Figure 3.118 shows some of the basic symbols that are used to designate contacts on schematic diagrams.

3.12.1.11 Resistors

Electricity travels through a conductor (wire) easily and efficiently, with almost no other energy released as it passes. On the other hand, electricity cannot travel through a resistor easily. When electricity is forced through a resistor, often the energy in the electricity is changed into another form of energy, such as light or heat. The reason why a light bulb glows is that electricity is forced through the tungsten filament, which is a resistor. Resistors are commonly used for controlling the current flowing in a circuit. A *fixed resistor* provides a constant amount of resistance in a circuit. A *variable resistor* (also called a *potentiometer*) can be adjusted to provide varying amounts of resistance, such as in a dimmer switch for lighting systems. A resistor also acts as a load in a circuit, in that there is always a voltage drop across it. Figure 3.119 shows some of the basic symbols that are used to designate resistors on schematic diagrams. A summary of basic electrical symbols that are used to designate electrical components or devices on schematic diagrams is provided in Figure 3.120.

3.12.2 Reading Plant Schematics

The information provided in the preceding sections on electrical schematic symbols and their functions should help in reading simple schematic diagrams. Many of the schematics used in wastewater treatment operations are of simple motor circuits, such as the one shown in Figure 3.121, which is for a reversing motor starter.

Note: The *reversing starter* has two starters of equal size for a given horsepower motor application. The reversing of a three-phase, squirrel-cage induction motor is accomplished by interchanging any two line connections to the motor. The concern is to properly connect the two

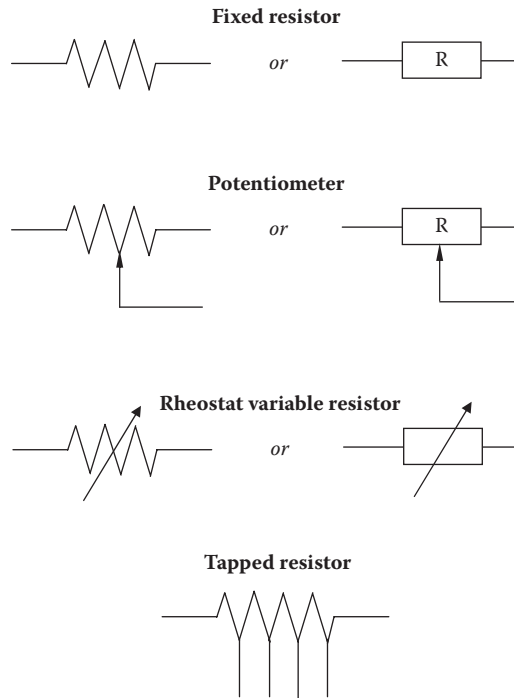

Figure 3.119 Resistor symbols.

starters to the motor so the line feed from one starter is different from the other. Both mechanical and electrical interlocks are used to prevent both starters from closing their line contacts at the same time. Only one set of overloads is required, as the same load current is available for both directions of rotation.

From the schematic shown in Figure 3.121, it can be seen that the motor is connected to the power source by the three power lines (line leads) L_1 , L_2 , and L_3 . The circuits for forward and reverse drive are also shown. For forward drive, lead L_1 is connected to terminal T_1 (known as a T lead) on the motor. Likewise, L_2 is connected to T_2 and L_3 to T_3 . When the three normally open F contacts (F for forward) are closed, these connections are made, current flows between the power source and the motor, and the motor rotor turns in the forward direction. In the reverse drive condition, the three leads (L_1 , L_2 , L_3) connect to a set of R contacts. The R contacts reverse the connections of terminals T_1 and T_3 , which reverses the rotation of the motor rotor. To reverse the motor, the three normally open R contacts must close and the F contacts must be open. The three fuses located on lines L_1 , L_2 , and L_3 protect the circuit from overloads. Moreover, three thermal overload cutouts protect the motor from damage.

Note: In actual operation, the circuit shown in Figure 3.121 utilizes a separate control to open or close the forward and reverse contacts. It has a mechanical interlock to make sure the R contacts stay open when the F contacts are closed, and *vice versa*.

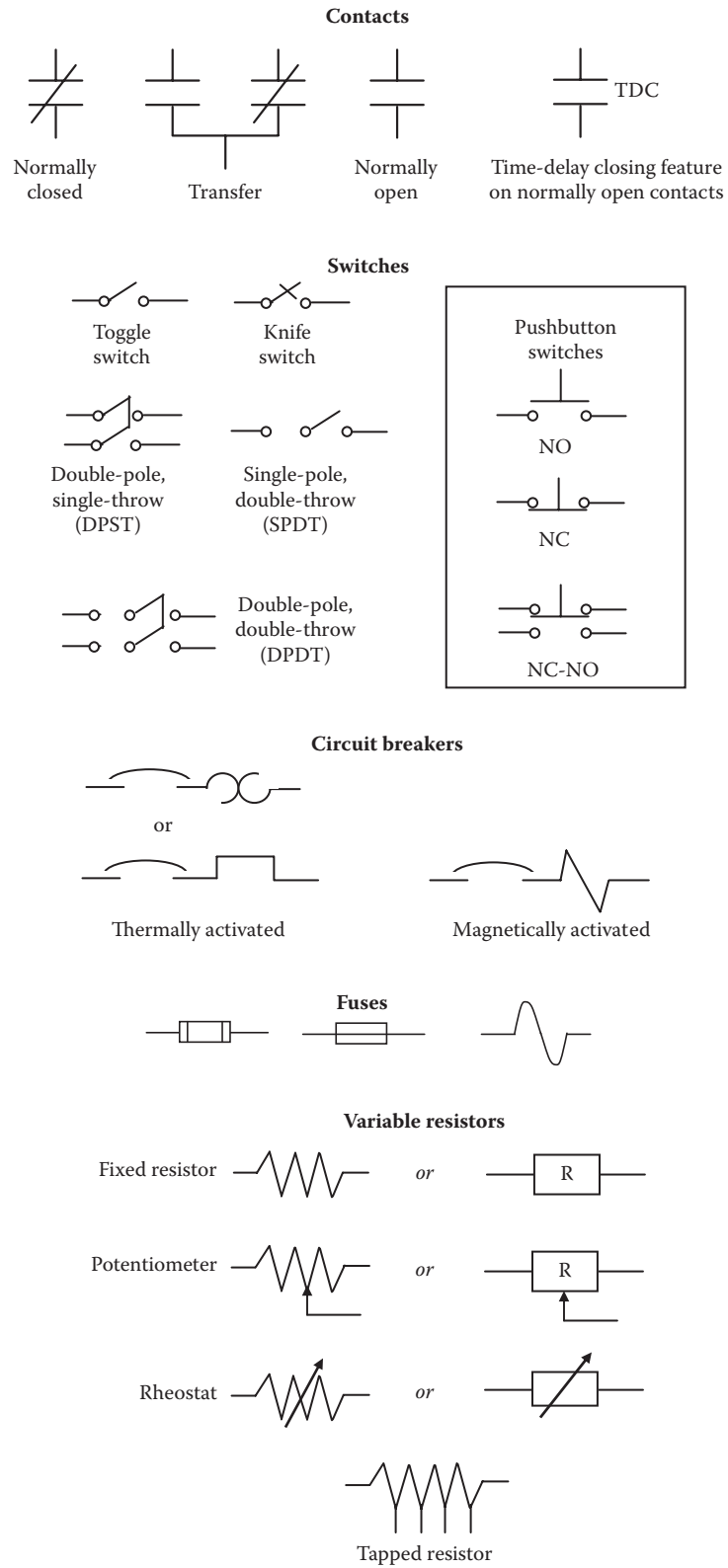
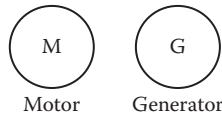
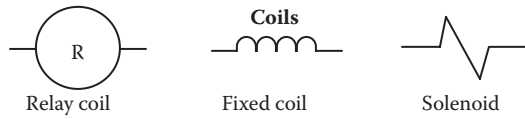
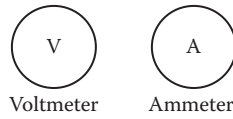

Figure 3.120 Summary of electrical symbols.

Motors and generators



Meters



Transformers

Iron core (shown only where necessary for clarity)



Special symbols

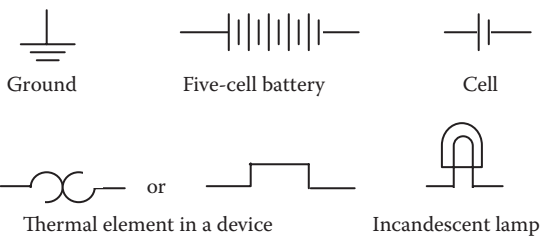

Wires

Single wire (in a construction diagram, a wire concealed in a wall or ceiling) 

Wiring concealed in floor (in a construction diagram) 

Exposed wiring (in a construction diagram) 

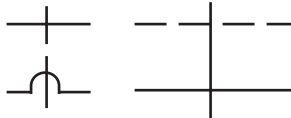
Wires crossing but not connected 

Wires connected (dot required) 

Figure 3.120 (cont.) Summary of electrical symbols.

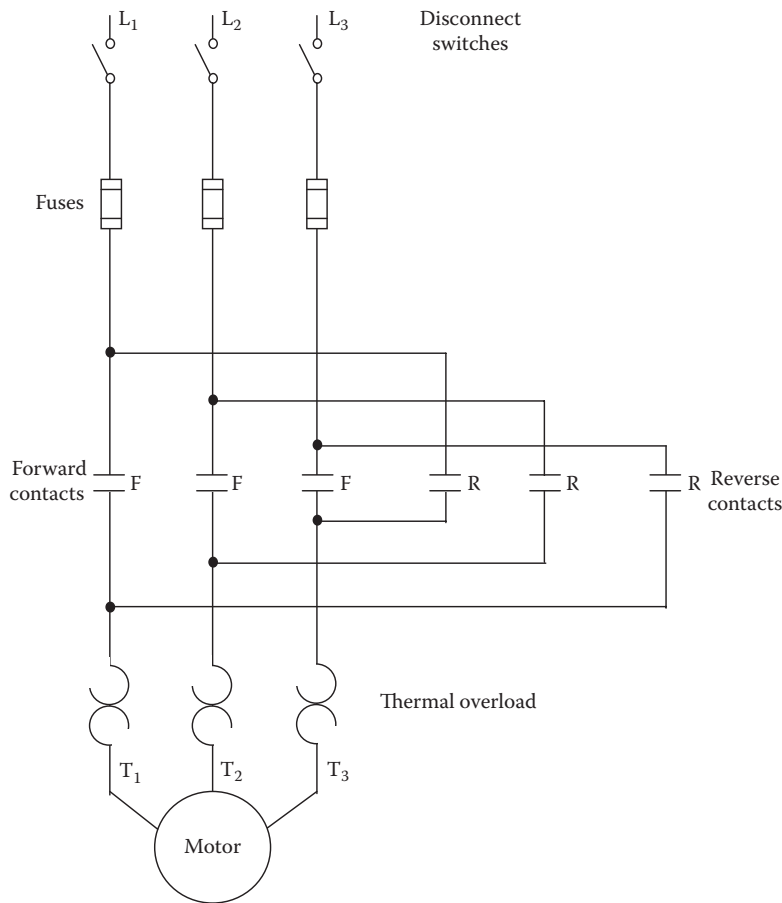

Figure 3.121 Schematic of motor controller.

3.13 GENERAL PIPING SYSTEMS AND SYSTEM SCHEMATICS

It would be difficult to imagine any modern wastewater treatment process without pipes. Pipes convey all the fluids—that is, the liquids, gases, and semisolids (sludge or biosolids)—either processed or used in plant operations. In addition to conveying wastewater influent into the plant for treatment, piping systems also bring in water for drinking, for flushing toilets, and for removing wastes. They also carry steam or hot water for heating, refrigerant for cooling, pneumatic and hydraulic fluids (gases and liquids flow under pressure) for equipment operation, and gas for auxiliary uses (e.g., for incineration of biosolids, methane off-gases for heating).

With the exception of in-ground interceptor lines, in wastewater operations almost all pipes are visible; however, they may be arranged in complex ways that look confusing to the untrained eye. Notwithstanding the complexity of a piping network, the maintenance operator can trace through a piping system, no matter how complex the system, by reading a piping schematic of the system. This section describes piping systems, piping system schematic diagrams, and schematic symbols typical of

water and wastewater operations, as well as schematic diagrams used for hydraulic/pneumatic systems and AC&R systems and how piping system symbols are used to represent various connections and fittings used in piping arrangements.

3.13.1 Piping Systems

Pipe is used for conveying fluids (liquid and gases)—water, steam, wastewater, petroleum, off-gases, and chemicals—and for structural elements such as columns and handrails. Pipe can carry semisolid material (sludge or biosolids), if it is processed fine enough and mixed with liquid. The choice of the type of pipe is determined by the purpose for which it is to be used. A *pipe* is defined as an enclosed, stationary device that conducts a fluid or a semisolid from one place to another in a controlled way. A *piping system* is a set of pipes and control devices that work together to deliver a fluid where it is needed, in the right amount, and at the proper rate.

Pipes are made of several kinds of solid materials. They can be made of wood, glass, porcelain, cast iron, lead, aluminum, stainless steel, brass, copper, plastic, clay, concrete, plastic, lead, and many other materials. Cast iron, steel, wrought iron, brass, copper, plastic, and lead pipes are most commonly used for conveying wastewater.

When conveying a substance in a piping system, the flow of the substance must be controlled. The substance must be directed to the place where it is needed. The amount of substance that flows and how quickly it flows must be regulated. The flow of a substance in a piping system is controlled, adjusted, and regulated by *valves*. This section describes the symbols that represent valves on various kinds of piping schematics, as well as basic *joints* and other fittings used in piping systems.

3.13.2 Identifying Piping Symbols

To read piping schematics correctly, maintenance operators must identify and understand the symbols used. It is not necessary to memorize them, but maintenance operators should keep a table of basic symbols handy and refer to it whenever the need arises. The following sections describe most of the common symbols used in general piping systems.

3.13.3 Piping Joints

The joints between pipes, fittings, and valves may be screwed (or threaded), flanged, welded, or, for nonferrous materials, soldered. A joint is the connection between two elements in a piping system. The five major types of joints are screwed (or threaded joints), welded, flanged, bell-and-spigot, and soldered.

3.13.3.1 Screwed Joints

Screwed joints are threaded together; that is, screwed joints can be made up tightly by simply screwing the threads together. Figure 3.122 shows the schematic symbol for a screwed joint. Screwed joints are usually used with pipe ranging from 1/4 inch to about 6 inches in diameter.

Note: In most screwed joints, the threads are on the inside of the fitting and on the outside of the pipe.

3.13.3.2 Welded Joints

Piping construction employing welded joints is almost universal practice today. This kind of joint is used when the coupling must be permanent, particularly for higher pressure and temperature conditions. Figure 3.123 shows the schematic symbol for welded joints.

Note: Welded joints may be either socket welded or butt welded.

3.13.3.3 Flanged Joints

Flanged joints are made by bolting two flanges together with a gasket between the flange faces. Flanges may be attached to the pipe, fitting, or appliance by means of a screwed joint, by welding, by lapping the pipe, or by being cast integrally with the pipe, fitting, or appliance. A flanged joint is shown in Figure 3.124, along with the symbol used on schematics.

3.13.3.4 Bell-and-Spigot Joints

Cast-iron pipes for handling wastewater, in particular, usually fit together in a special way. When each fitting and section of pipe is cast, one end is made large enough to fit loosely around the opposite end of another fitting or pipe. When this type of fitting is connected, it forms a bell-and-spigot joint. Figure 3.125 shows the symbol for a bell-and-spigot joint that is used on schematics.



Figure 3.122 Screwed joint symbol. **Figure 3.123** Welded joint symbol.

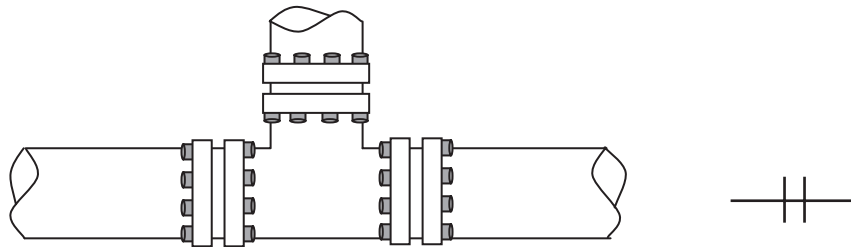

Figure 3.124 Flanged joint and symbol.

3.13.3.5 Soldered Joints

Nonferrous fittings, such as copper piping and fittings, are often joined by soldering them with a torch or soldering iron and then melting solder on the joint. The solder flows into the narrow space between the two mating parts and seals the joint. Figure 3.126 shows the schematic symbol for a soldered joint.



Figure 3.125 Symbol for bell-and-spigot joint.



Figure 3.126 Symbol for soldered joint.

3.13.3.6 Symbols for Joints and Fittings

Figure 3.127 shows most of the common schematic piping joint and fitting symbols (for elbows only) used today; however, it does not show all the symbols used on all piping schematics.

3.13.4 Valves

Any wastewater operation will have many valves that are important components of different piping systems. Simply as a matter of routine, a maintenance operator must be able to identify and locate valves to inspect them, adjust them, and repair or replace them. For this reason, the maintenance operator should be familiar with schematic diagrams that include valves and with schematic symbols used to designate valves.

3.13.4.1 Valves: Definition and Function

A *valve* is defined as any device by which the flow of fluid may be started, stopped, or regulated by a movable part that opens or obstructs passage (DOE, 1993). As applied in fluid power systems, valves are used for controlling the flow, the pressure, and the direction of the fluid flow

	45 Degree	90 Degree	90 Degree Away	90 Degree Forward
Flanged				
Screwed				
Welded				
Bell-and-spigot				
Soldered or brazed				

Figure 3.127 Symbols for elbow fittings.

through a piping system. The fluid may be a liquid, a gas, or some loose material in bulk (such as a biosolids slurry). Designs of valves vary, but all valves have two features in common:

- A passageway through which fluid can flow
- Some kind of movable (usually machined) part that opens and closes the passageway.

Note: It is all but impossible, obviously, to operate a practical fluid power system without some means of controlling the volume and pressure of the fluid and directing the flow of fluid to the operating units. This is accomplished by the incorporation of various types of valves.

Whatever type of valve is used in a system, it must be accurate in the control of fluid flow and pressure and the sequence of operation. Leakage between the valve element and the valve seat is reduced to a negligible quantity by precision-machined surfaces, resulting in carefully controlled clearances. This, of course, is one of the very important reasons for minimizing contamination in fluid power systems. Contamination causes valves to stick, plugs small orifices, and causes abrasions of the valve seating surfaces, which results in leakage between the valve element and valve seat when the valve is in the closed position. Any of these can result in inefficient operation or complete stoppage of the equipment. Valves may be controlled manually, electrically, pneumatically, mechanically, hydraulically, or by combinations of two or more of these methods. Factors that determine the method of control include the purpose of the valve, the design and purpose of the system, the location of the valve within the system, and the availability of the source of power.

Valves are made from bronze, cast iron, steel, Monel[®], stainless steel, and other metals. They are also made from plastic and glass. Special valve trim is used where seating and sealing materials are different from the basic material of construction; valve trim usually refers to those internal parts of a valve controlling the flow and in physical contact with the line fluid. Valves are made in a full range of sizes that match pipe and tubing sizes. Actual valve size is based on the internationally agreed definition of nominal size. *Nominal size* (DN) is a numerical designation of size that is common to all components in a piping system other than components designated by outside diameters. It is a convenient number for reference purposes and is only loosely related to manufacturing dimensions.

Valves are made for service at the same pressures and temperatures to which the piping and tubing are subject. Valve pressures are based on the internationally agreed definition of nominal pressure. *Nominal pressure* (PN) is a pressure that is conventionally accepted or used for reference purposes. All equipment of the same nominal size (DN) designated by the same nominal pressure number must have the same mating dimensions appropriate to the type of end connections. The permissible working pressure depends on materials, design, and working temperature and should be selected from the (relevant) pressure/temperature

TABLE 3.4 VALVE SPECIAL FEATURES

High-temperature	Valves are usually able to operate continuously on services above 250°C.
Cryogenic	Valves will operate continuously on services in the range of -50°C to 196°C.
Bellows-sealed	Valves are glandless designs having a metal bellows for stem sealing.
Actuated	Valves may be operated by a gear box, pneumatic or hydraulic cylinder (including diaphragm actuator), or electric motor and gear box.
Fire-tested design	Refers to a valve that has passed a fire test procedure specified in an appropriate inspection standard.

tables. The pressure rating of many valves is designated under the ANSI classification system. Class ratings equivalent to PN ratings are based on international agreement. Usually, valve end connections are classified as flanged, threaded, or other. Valves are also covered by various codes and standards, as are the other components of piping and tubing systems. Many valve manufacturers offer valves with special features. Table 3.4 lists a few of these special features; however, this is not an exhaustive list. For more details of other features, the various manufacturers should be consulted.

3.13.4.2 Valve Construction

Figure 3.128 shows the basic construction and principle of operation of a common valve type. Fluid flows into the valve through the inlet. The fluid flows through passages in the body and past the opened element that closes the valve. It then flows out of the valve through the outlet or discharge. If the closing element is in the closed position, the passageway is blocked. Fluid flow is stopped at that point. The closing element keeps the flow blocked until the valve is opened again. Some valves are opened automatically, and others are controlled by manually operated handwheels. Other valves, such as check valves, operate in response to pressure or the direction of flow.

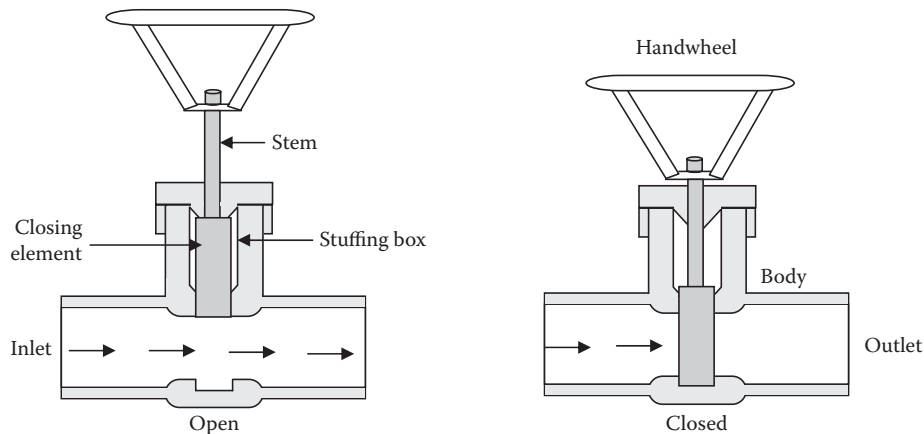

Figure 3.128 Basic valve operation.

3.13.4.3 Types of Valves

The types of valves covered in this text include the following:

- Ball valve
- Cock valve
- Gate valve
- Globe valve
- Check valve

Each of these valves is designed to control the flow, pressure, or direction of fluid flow, or for some other special application. With a few exceptions, these valves take their names from the type of internal element that controls the passageway. The exception is the check valve.

3.13.4.3.1 Ball Valve

Ball valves, as the name implies, are stop valves that use a ball to stop or start a flow of fluid. The ball performs the same function as the disk in other valves. As the valve handle is turned to open the valve, the ball rotates to a point where part or all of the hole through the ball is in line with the valve body inlet and outlet, allowing fluid to flow through the valve. When the ball is rotated so the hole is perpendicular to the flow openings of the valve body, the flow of fluid stops. Most ball valves are the quick-acting type. They require only a 90° turn to completely open or close the valve. Others are operated by planetary gears. This type of gearing allows the use of a relatively small handwheel and operating force to operate a fairly large valve. The gearing does, however, increase the operating time for the valve. Some ball valves also contain a swing check located within the ball to give the valve a check valve feature. The two main advantages of using ball valves are that: (1) the fluid can flow through it in either direction, as desired, and (2) when closed, pressure in the line helps to keep it closed. Symbols that represent the ball valve in schematic diagrams are shown in Figure 3.129.

3.13.4.3.2 Cock Valves

The cock valve, like the gate valve, has only two positions: on and off. The difference is in the speed of operation. The gate valve, for example, opens and closes gradually. The cock valve opens and closes quickly and is used when the flow must be started quickly or stopped quickly. The schematic symbols for a cock valve appear in Figure 3.130.

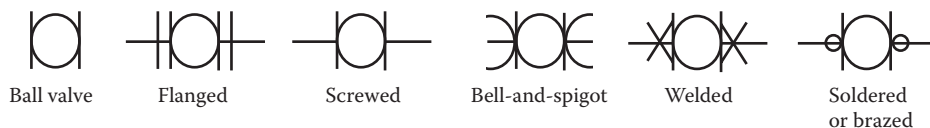

Figure 3.129 Symbols for ball valves.

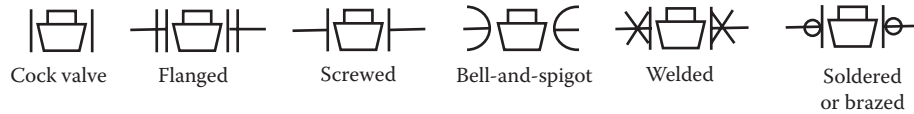

Figure 3.130 Symbols for cock valves.



Figure 3.131 Symbols for gate valves.

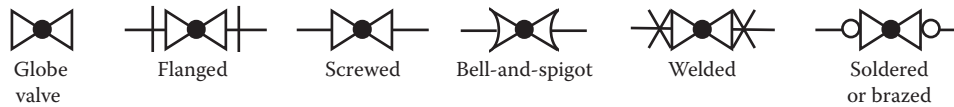

Figure 3.132 Symbols for globe valves.

3.13.4.3.3 Gate Valves

Gate valves are used when a straight-line flow of fluid and minimum flow restriction are necessary; they are the most common type of valve found in a water distribution system. Gate valves are so named because the part that either stops or allows flow through the valve acts somewhat like a gate. The gate is usually wedge shaped. When the valve is wide open, the gate is fully drawn up into the valve bonnet. This leaves an opening for flow through the valve the same size as the pipe in which the valve is installed. For these reasons, the pressure loss (pressure drop) through these types of valves is about equal to the loss in a piece of pipe of the same length. Gate valves are not suitable for throttling (controlling the flow by means of intermediate steps between fully open and fully closed) purposes. The control of flow is difficult because of the design of the valve, and the flow of fluid slapping against a partially open gate can cause extensive damage to the valve. The schematic symbols for a gate valve appear in Figure 3.131.

Note: Gate valves are well suited to service on equipment in distant locations, where they may remain in the open or closed position for a long time. Generally, gate valves are not installed where they will need to be operated frequently because they require too much time to switch from being fully open to closed (AWWA, 1998).

3.13.4.3.4 Globe Valves

Probably the most common valve type in existence, the globe valve is commonly used for water faucets and other household plumbing. As illustrated in Figure 3.132, these valves have a circular disk (globe) that presses against the valve seat to close the valve. The disk is the part of the globe valve that controls flow. The disk is attached to the valve stem.

Fluid flow through a globe valve is at right angles to the direction of flow in the conduits. Globe valves seat very tightly and can be adjusted with fewer turns of the wheel than gate valves; thus, they are preferred for applications that call for frequent opening and closing. On the other hand, globe valves create high head loss when fully open, so they are not suited in systems where head loss is critical. The schematic symbols that represent the globe valve are also shown in Figure 3.132.

Note: The globe valve should never be jammed in the open position. After a valve is fully opened, the handwheel should be turned toward the closed position approximately one-half turn. Unless this is done, the valve is likely to seize in the open position, making it difficult, if not impossible, to close the valve. Another reason for not leaving a globe valve in the fully open position is that it is sometimes difficult to determine if the valve is open or closed (DOE, 1993).

3.13.4.3.5 Check Valves

Check valves are usually self-acting and designed to allow the flow of fluid in one direction only. They are commonly used at the discharge of a pump to prevent backflow when the power is turned off. When the direction of flow is moving in the proper direction, the valve remains open. When the direction of flow reverses, the valve closes automatically from the fluid pressure against it. Several types of check valves are used in wastewater operations, including:

- Slanting-disk check valves
- Cushioned swing check valves
- Rubber-flapper swing check valves
- Double-door check valves
- Ball check valves
- Foot valves
- Backflow prevention devices

In each case, pressure from the flow in the proper direction pushes the valve element to an open position. Flow in the reverse direction pushes the valve element to a closed position. Symbols that represent check valves are shown in Figure 3.133, and Figure 3.134 summarizes the standard symbols for valves discussed in this text.

Note: Check valves are also commonly referred to as *nonreturn* or *reflux valves*.

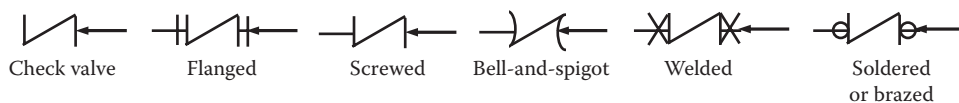

Figure 3.133 Symbols for check valves.

3.14 HYDRAULIC AND PNEUMATIC SYSTEM SCHEMATIC SYMBOLS

In wastewater operations, hydraulic and pneumatic systems are very common. For maintenance operators, training and developing the skills necessary to solve various problems that may occur in hydraulic and pneumatics systems in the plant are critical. The purpose of this section is to provide the basic operating principles of hydraulic and pneumatic systems so maintenance operators will be able to diagnose and fix hydraulic and pneumatic equipment. To fix hydraulic and pneumatic equipment, maintenance operators must be familiar with the symbols used in the diagrams of these systems.

3.14.1 Fluid Power Systems

Fluid power is the generation, control, and application of smooth, effective power of pumped or compressed fluids (either liquids or gases) to provide force and motion to mechanisms. The force and motion may be in the form of pushing, pulling, rotating, regulating, or driving. Fluid power includes *hydraulics*, which involves liquids, and *pneumatics*, which involves gases. Liquids and gases are similar in many respects. They do not, however, behave in the same way under pressure. Moreover, even the terms used for some of the basic components of both types of fluid-power systems are different—as are some of the symbols. In any hydraulic or pneumatic fluid-power systems, the basic components include:

- A *reservoir* stores the fluid in a hydraulic system. In a pneumatic system, this is referred to as a *receiver*.
- The *pump* in a hydraulic system provides the pressure that results in work; in a pneumatic system, it is referred to as a *compressor*.
- In both systems, the *actuator* reacts to the pressure of the fluid and does the work.
- *Valves* direct and adjust the flow of fluid in both systems.
- The lines that circulate the fluid are called *pipng* in a hydraulic system and *tubing* in a pneumatic system.

Valve	Flanged	Screwed	Bell-and-spigot	Welded	Soldered or brazed
Gate valve					
Globe valve					
Cock valve					
Ball valve					
Check valve					

Figure 3.134 Standard symbols for valves.

















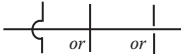





Lines and Line Functions			
Line, working		Line, pilot	
Line, drain		Connector (dot is 5× the thickness of the line)	
Line, flexible		Lines, joining	
Lines, crossing		Direction of flow	
Line to reservoir, above fluid level and below fluid level		Line to vented manifold	
Pumps			
Pump, fixed displacement		Pump, variable displacement	
Motors			
Motor, hydraulic, fixed displacement		Motor, pneumatic, variable displacement	
Valves			
Valve, check		Valve, single flow path, basic symbol	
Valve, maximum pressure (relief) normally closed		Valve, single flow path, normally open	
Valve, multiple flow paths, basic symbol		Valve, single flow path, normally closed	
Valve, multiple flow paths, closed position		Valve, manual shutoff	

Figure 3.135 Symbols for hydraulic and pneumatic components.

3.14.2 Symbols Used for Hydraulic and Pneumatic Components

A schematic diagram explains how a hydraulic or pneumatic system operates. It is made up of symbols. Keep in mind that some of these symbols are combinations of other, more basic symbols. To understand the operation of a hydraulic or pneumatic system, the maintenance operator must be familiar with the symbols shown in Figure 3.135.

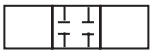
3.14.3 AC&R System Schematic Symbols

Major components of AC&R systems and system operation were explained earlier. This section describes the symbols for the components described earlier. An understanding of AC&R schematic symbols enables the maintenance operator to more effectively and efficiently troubleshoot AC&R systems.

Note: In practice, refrigeration piping diagrams may be either orthographic or isometric projections. Air-distribution systems can be either

Refrigerant discharge	—— RD ——	Chilled water supply	—— CH ——
Refrigerant suction	- - - RD - - -	Chilled water return	- - - CHR - - -
Brine supply	—— B ——	Fill line	—— FILL ——
Brine return	- - - BR - - -	Humidification line	- - - · H - - -
Condenser water flow	—— C ——	Drain	—— D ——
Condenser water return	- - - CR - - -		

Figure 3.136 Symbols for refrigeration lines.

double-line or single-line schematics. For our purposes, we refer to diagrams for both systems as *schematics*. The importance rests not in the type of drawing but in recognition of the symbols used in both systems.

3.14.4 Schematic Symbols Used in Refrigeration Systems

Many of the components used in refrigeration systems include components described in other sections of this text. These components include electrical, piping, hydraulic, and pneumatic equipment. Refrigeration piping, however, conveys both gases and liquids; therefore, the symbols used sometimes differ from symbols used in simpler piping systems. In the following sections, we describe both these differences and the symbols used.

3.14.4.1 Refrigeration Piping Symbols

In refrigeration systems, three different kinds of piping are used, depending on whether the refrigerant is a gas or a liquid, or both; for example, the discharge line going from the compressor to the condenser carries hot gas at high pressure. The liquid line going from the condenser to the receiver and from the receiver to the expansion valve carries lower temperature liquid at the same high pressure as the discharge side. The suction line going from the evaporator to the compressor intake valve conveys relatively cool refrigerant vapor at low pressures. Figure 3.136 shows refrigeration line symbols used on refrigeration schematic drawings.

3.14.4.2 Refrigeration Fittings Symbols

Refrigeration fittings are connected by brazing, threading, flanging, or welding. Figure 3.137 shows the symbols for screwed or threaded connections. Symbols for fittings with other connections have the same body shapes.









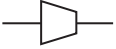
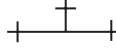

Bushing		Tee	
Connection, bottom		Cap	
Coupling (joint)		Connection, top	
Elbow, 90°		Cross	
Elbow, turned down		Elbow, 45°	
Elbow, reducing		Reducer, concentric	

Figure 3.137 Symbols for refrigeration fittings.

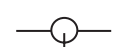

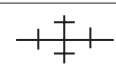





Air line		Safety valve	
Pressure-reducing		Cock valve	
Quick-opening		Control, two-way	
Solenoid		Control, three-way	

Figure 3.138 Symbols for refrigeration valves.

3.14.4.3 Refrigeration Valve Symbols

Like refrigeration fittings, valves used in refrigeration systems are brazed, threaded, flanged, or welded. Figure 3.138 shows the symbols for various valves.

3.14.4.4 Refrigeration Accessory Symbols

Specialized piping accessories are used in refrigeration systems. These accessories include expansion joints, driers, strainers, heat exchangers, filters, and other devices. Symbols for these devices are shown in Figure 3.139.

3.14.4.5 Refrigeration Component Symbols

In addition to piping, fittings, accessories, and valves, various major components make up a refrigeration system. These components include a compressor, an evaporator, condensers, refrigerant receivers and accumulators, and heat exchangers. Symbols for these components are shown in Figure 3.140.

Air eliminator		Expansion joint	
Refrigerant filter and strainer		Vibration absorber	
Oil separator		Line filter	
Drier		Heat exchanger	

Figure 3.139 Symbols for refrigeration accessories.

Compressor, centrifugal		Compressor, rotary	
Evaporator, finned type, natural convection		Condenser, air-cooled, forced air	
Condenser, water-cooled shell and tube		Condenser, evaporative	
Cooling tower		Receiver, horizontal	
Spray pond		Receiver, vertical	
Electric motor (number indicates horsepower)		Engine (letter indicates fuel)	

Figure 3.140 Symbols for refrigeration.

Duct		Exhaust duct section	
Splitter damper		Turning vanes	
Supply outlet, ceiling diffuser		Direction of flow	
Supply duct section		Access door	



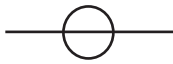

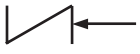

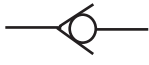
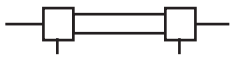
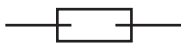





Figure 3.141 Symbols for ducting.

3.14.4.6 Schematic Symbols Used in AC&R Air-Distribution System

A major subsystem of an AC&R system is air distribution. Air is distributed to various spaces that require cooling or heating (if the system is equipped with both heating and cooling equipment). The air is delivered through ducting systems. Figure 3.141 shows standard symbols for ducting schematics.

3.15 CHAPTER REVIEW QUESTIONS

The symbols below represent various components used in blueprints or schematics for electrical, welding, hydraulic, pneumatic, piping, and AC&R systems. Identify the meaning of each symbol. Use the space alongside each symbol to describe what the symbol represents.

- | | | |
|------|---|--|
| 3.1 |  | |
| 3.2 |  | |
| 3.3 |  | |
| 3.4 |  | |
| 3.5 |  | |
| 3.6 |  | |
| 3.7 |  | |
| 3.8 |  | |
| 3.9 |  | |
| 3.10 |  | |
| 3.11 |  | |
| 3.12 |  | |
| 3.13 |  | |
| 3.14 |  | |
| 3.15 |  | |
| 3.16 |  | |
| 3.17 |  | |

3.18  _____

3.19  _____

3.20  _____

3.21  _____

3.22  _____

3.23  _____

3.24  _____

3.25  _____

3.26  _____

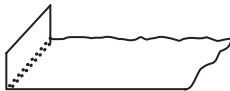
3.27  _____

3.28  _____

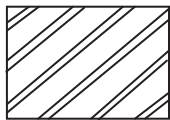
3.29  _____

3.30  _____

3.31  _____

3.32  _____

3.33 If the scale box says 4, it means the object is drawn at _____.

3.34 What is the basic identification assigned to a drawing?

3.35 When two lines cross, the sum of any two adjacent angles is always _____ degrees.

3.36 A ruled line and a zig-zag line for long breaks indicate _____.

3.37 What type of line represents the outline of an object?

3.38 A _____ displays three sides of an object.

3.39 The number and the selection of views are governed by the _____ and _____ of the object.

- 3.40 _____ are the maximum and minimum sizes indicated by a toleranced dimension.
- 3.41 Location dimensions are usually made from either a _____ or a _____.
- 3.42 A pump casing is called the _____.
- 3.43 _____ are used to eliminate the raw edge and also to stiffen the material.
- 3.44 In drawing a pattern on sheet metal, you should provide some extra metal for making a _____.
- 3.45 A _____ is set to open and bleed off some of the air if the pressure becomes too high.
- 3.46 A _____ is easier to compress than a _____.
- 3.47 What kind of joint joins the edges of two metals without overlapping?
- 3.48 An _____ drawing shows the physical locations of the electric lines in a plant building.
- 3.49 What shows how electrical power is distributed in all buildings?
- 3.50 What is another name for a schematic diagram?

REFERENCES AND RECOMMENDED READING

ANSI. (1973a). *Line Conventions and Lettering*. New York: American National Standards Institute.

ANSI. (1973b). *Dimension and Tolerance*. New York: American National Standards Institute.

ANSI. (1980). *ANSI Y14.1: Blueprint Sheet Size*. New York: American National Standards Institute.

ANSI. (1982). *Dimensioning and Tolerancing*. New York: American National Standards Institute.

ANSI/AWS. (1991). *A2.4-93 Welding: An American National Standard*. New York: American National Standards Institute/American Welding Society.

AWS. (1996). *Materials and Applications. Part I. Welding Handbook*, Vol. 3, 8th ed. Miami, FL: American Welding Society.

AWWA. (1998). *Water Transmission and Distribution*, 2nd ed. Denver, CO: American Water Works Association.

Brown, W.C. (1989). *Blueprint Reading for Industry*. South Holland, IL: The Goodheart-Wilcox Company.

Cheremisinoff, N.P. and Cheremisinoff, P.N. (1989). *Pumps, Compressors, Fans: Pocket Handbook*. Boca Raton, FL: CRC Press.

DOE. (1993). *Mechanical Science. Module 4. Valves*, DOE-HDBK-1018/2-93. Washington, D.C.: U.S. Department of Energy.

Olivo, C.T. and Olivo, T.P. (1999). *Basic Blueprint Reading and Sketchings*, 7th ed. Albany, NY: Delmar Publishers.

Spellman, F.R. (2000). *Spellman's Standard Handbook for Wastewater Operators*, Vol. 3. Boca Raton, FL: CRC Press.

Spellman, F.R. and Drinan, J. (2000a). *Pumping*. Boca Raton, FL: CRC Press.

Spellman, F.R. and Drinan, J. (2000b). *Electricity*. Boca Raton, FL: CRC Press.

Spellman, F.R. and Drinan, J. (2001). *Piping and Valves*. Boca Raton, FL: CRC Press.

ADVANCED WASTEWATER TREATMENT

4.1 INTRODUCTION

Advanced wastewater treatment is defined as the methods or processes that remove more contaminants (suspended and dissolved substances) from wastewater than are taken out by conventional biological treatment. Put another way, advanced wastewater treatment is the application of a process or system following secondary treatment or is a process that includes phosphorus removal or nitrification in conventional secondary treatment.

Advanced wastewater treatment is used to augment conventional secondary treatment because secondary treatment typically removes only 85 to 95% of the biochemical oxygen demand (BOD) and total suspended solids (TSS) in raw sanitary sewage. Generally, this leaves 30 mg/L or less of BOD and TSS in the secondary effluent. To meet stringent water quality standards, this level of BOD and TSS in secondary effluent may not prevent violation of water quality standards—the plant may not make permit. For this reason, advanced wastewater treatment is often used to remove additional pollutants from treated wastewater.

In addition to meeting or exceeding the requirements of water quality standards, treatment facilities use advanced wastewater treatment for other reasons, as well. Sometimes, for example, conventional secondary wastewater treatment is not sufficient to protect the aquatic environment. When periodic flow events occur, a stream may not provide the amount of effluent dilution necessary to maintain adequate dissolved oxygen (DO) levels for aquatic organism survival.

Secondary treatment has other limitations. It does not significantly reduce the effluent concentration of nitrogen and phosphorus (important plant nutrients) in sewage. An abundance of these nutrients can overstimulate plant and algae growth such that they create water quality problems; for example, when they are discharged into lakes, these nutrients contribute to algae blooms and accelerated eutrophication (lake aging). Also, nitrogen in sewage effluent may be present primarily in the form of ammonia compounds. At a high enough concentration, ammonia compounds are toxic to aquatic organisms. Yet another problem with these compounds is that they exert a nitrogenous oxygen demand in the receiving water, as they convert to nitrates. This process is called *nitrification*.

Note: The term *tertiary treatment* is commonly used as a synonym for advanced wastewater treatment; however, these two terms do not have precisely the same meaning. Tertiary suggests a third step that is applied after primary and secondary treatment.

Advanced wastewater treatment can remove more than 99% of the pollutants from raw sewage and can produce an effluent of almost potable (drinking) water quality. Obviously, however, advanced treatment is not cost free. The cost of advanced treatment—operation and maintenance costs, as well as the cost to retrofit existing conventional processes—is very high, sometimes doubling the cost of secondary treatment. A plan to install advanced treatment technology calls for careful study, as the benefit-to-cost ratio is not always great enough to justify the additional expense.

Despite the expense, application of some form of advanced treatment is not uncommon. These treatment processes can be chemical, physical, or biological. The specific process used is based on the purpose of the treatment and the quality of the effluent desired.

4.2 CHEMICAL TREATMENT

The purpose of chemical treatment is to remove:

- Biochemical oxygen demand (BOD)
- Total suspended solids (TSS)
- Phosphorus
- Heavy metals
- Other substances that can be chemically converted to a settleable solid

Chemical treatment is often accomplished as an “add-on” to existing treatment systems or by means of separate facilities specifically designed for chemical addition. In each case, the basic process necessary to achieve the desired results remains the same:

- Chemicals are thoroughly mixed with the wastewater.
- The chemical reactions that occur form solids (coagulation).

- The solids are mixed to increase particle size (flocculation).
- Settling or filtration (separation), or both, then removes the solids.

The specific chemical used depends on the pollutant to be removed and the characteristics of the wastewater. These chemicals may include any of the following:

- Lime
- Alum (aluminum sulfate)
- Aluminum salts
- Ferric or ferrous salts
- Polymers
- Bioadditives

4.2.1 Operational Considerations

Operation and observation of the performance of chemical treatment processes are dependent on the pollutant being removed and on process design. Operational problems associated with chemical treatment processes used in advanced treatment usually revolve around problems with floc formation, settling characteristics, removal in the settling tank, and sludge (in settling tank) turning anaerobic. To correct these problems, the operator must be able to recognize the applicable problem indicators through proper observation. In the following sections, we list common indicators and observations of operational problems, along with the applicable causal factors and corrective actions.

- **Symptom 1.** Poor floc formation and settling characteristics

Causal factors: Insufficient chemical dispersal during rapid mix; excessive detention time in rapid mix; improper coagulant dosage; excessive flocculator speed

Corrective actions: Increase speed of rapid mixer; reduce detention time to 15 to 60 seconds; correct the dosage (determine by jar testing); reduce flocculator speed.

- **Symptom 2.** Good floc formation, poor removal in settling tank

Causal factors: Excessive velocity between flocculation and settling; settling tank operational problem

Corrective action: Reduce velocity to acceptable range.

- **Symptom 3.** Anaerobic settling tank sludge

Causal factors: Development of a sludge blanket in the settling tank; excessive organic carryover from secondary treatment

Corrective action: Increase sludge withdrawal to eliminate blanket; correct secondary treatment operational problems.

4.3 MICROSCREENING

Microscreening (also called *microstraining*) is an advanced treatment process used to reduce suspended solids. The microscreens are composed of specially woven steel wire fabric mounted around the perimeter of a large revolving drum. The steel wire cloth acts as a fine screen, with openings as small as 20 micrometers (or millionths of a meter), small enough to remove microscopic organisms and debris. The rotating drum is partially submerged in the secondary effluent, which must flow into the drum then outward through the microscreen. As the drum rotates, captured solids are carried to the top, where a high-velocity water spray flushes them into a hopper or backwash tray mounted on the hollow axle of the drum. Backwash solids are recycled to plant influent for treatment.

These units have found greatest application in the treatment of industrial waters and final polishing filtration of wastewater effluents. Expected performance for suspended solids removal is 95 to 99%, but the typical suspended solids removal achieved with these units is about 55%. The normal range is from 10 to 80%.

The functional design of the microscreen unit must take into account the following: (1) characterization of the suspended solids with respect to the concentration and degree of flocculation; (2) selection of unit design parameter values that will not only ensure capacity to meet maximum hydraulic loadings with critical solids characteristics but also provide desired design performance over the expected range of hydraulic and solids loadings; and (3) provision of backwash and cleaning facilities to maintain the capacity of the screen (Metcalf & Eddy, 2003).

4.3.1 Operational Considerations

Microscreen operators typically perform sampling and testing on influent and effluent TSS and monitor screen operation to ensure proper operation. Operational problems generally consist of a gradual decrease in throughput rate, leakage at the ends of the drum, reduced screen capacity, hot or noisy drive systems, erratic drum rotation, and sudden increases in effluent solids.

- **Symptom 1.** Decreased throughput rate (from slime growth)

Causal factors: Inadequate cleaning; plugged spray nozzles

Corrective actions: Increase backwash pressure (60 to 120 psi); add hypochlorite upstream of the unit; unclog nozzles.

- **Symptom 2.** Decreased performance due to leakage at ends of the drum

Causal factor: Defective/leaking units

Corrective actions: Tighten tension on the sealing bands; replace the sealing bands if excessive tension is required.

- **Symptom 3.** Reduced screen capacity after shutdown period
Causal factor: Fouled screen
Corrective actions: Clean screen prior to shutdown; clean screen with hypochlorite.
- **Symptom 4.** Drive system running hot or noisy
Causal factor: Inadequate lubrication
Corrective action: Fill to specified level with recommended oil.
- **Symptom 5.** Erratic drum rotation
Causal factors: Improper drive belt adjustment; worn-out drive belts
Corrective actions: Adjust tension to the specified level; replace drive belts.
- **Symptom 6.** Sudden increase in effluent solids
Causal factors: Hole in screen fabric; loose screws securing the fabric; overflowing solids collection trough
Corrective actions: Repair fabric; tighten screws; reduce micro-screen influent flow rate.
- **Symptom 7.** Decreased screen capacity after high-pressure washing
Causal factor: Iron or manganese oxide film on fabric
Corrective actions: Clean screen with inhibited acid cleaner; follow manufacturer's instruction.

4.4 FILTRATION

The purpose of filtration processes used in advanced treatment is to remove suspended solids. The specific operations associated with a filtration system are dependent on the equipment used. A general description of the process follows.

4.4.1 Filtration Process Description

Wastewater flows to a filter (either gravity or pressurized). The filter contains single, dual, or multimedia. Wastewater flows through the media, which removes solids. The solids remain in the filter. Backwashing the filter as needed removes trapped solids. Backwash solids are returned to the plant for treatment. Processes typically remove 95 to 99% of the suspended matter.

4.4.2 Operational Considerations

Operators routinely monitor filter operation to ensure optimum performance and to detect operational problems based on indications or observations of equipment malfunction or suboptimal process

performance. Operational problems typically encountered in filter operations are discussed below.

- **Symptom 1.** High effluent turbidity

Causal factors: Filter backwashing required; inadequate prior chemical treatment

Corrective actions: Backwash unit as soon as possible; adjust and control chemical dosage properly.

- **Symptom 2.** High head loss through the filter

Causal factor: Filter backwashing required

Corrective action: Backwash unit as soon as possible.

- **Symptom 3.** High head loss through unit right after backwashing

Causal factors: Insufficient backwash cycle; inoperative surface scour/wash arm

Corrective actions: Increase backwash time; repair air scour or surface scrubbing arm.

- **Symptom 4.** Backwash water requirement exceeding 5%

Causal factors: Excessive solids in filter influent; excessive filter aid dosage; inoperative surface washing/air scour system; surface washing/air scour system not operated long enough during backwash cycle; excessive backwash cycle

Corrective actions: Improve treatment prior to filtration; reduce or control filter aid dose rates; repair mechanical problem; increase surface wash cycle time; adjust backwash cycle length.

- **Symptom 5.** Clogged filter surface

Causal factors: Inadequate prior treatment (single-media filters); excessive filter aid dosage (dual or mixed media filters); inadequate surface wash cycle; inadequate backwash cycle

Corrective actions: Improve prior treatment; replace single media with dual or mixed media; reduce or eliminate filter aid; provide an adequate surface wash cycle; provide an adequate backwash cycle.

- **Symptom 6.** Short filter runs

Causal factor: High head loss

Corrective actions: See Symptom 5.

- **Symptom 7.** Rapidly increasing filter effluent turbidity

Causal factors: Inadequate filter aid dosage; filter aid system mechanical failure; changed filter aid requirement

Corrective actions: Increase chemical dosage; repair feed system; adjust filter aid dose rate (do jar test).

- **Symptom 8.** Mud ball formation

Causal factors: Inadequate backwash flow rate; inadequate surface wash

Corrective actions: Increase backwash flow to specified levels; increase surface wash cycle.

- **Symptom 9.** Gravel displacement

Causal factor: Air entering the underdrains during backwash cycle

Corrective actions: Control backwash volume; control backwash water head; replace media (severe displacement).

- **Symptom 10.** Media lost during backwash cycle

Causal factors: Excessive backwash flows; excessive auxiliary scour; media floating due to air attached to it

Corrective actions: Reduce backwash flow rate; stop auxiliary scour several minutes before the end of the backwash cycle; increase backwash frequency to prevent bubble displacement and maintain maximum operating water depth above filter surface.

- **Symptom 11.** Ineffective filter backwash cycle during warm weather

Causal factor: Decreased water viscosity due to the higher temperatures

Corrective action: Increase backwash rate until required bed expansion is achieved.

- **Symptom 12.** Premature head loss increase due to air binding

Causal factors: Air bubble produced by exposing an influent containing high dissolved oxygen levels to less than atmospheric pressure; pressure drops occurring during changeover to backwash cycle

Corrective actions: Increase backwash frequency; maintain maximum operating water depth.

4.5 BIOLOGICAL NITRIFICATION

Biological nitrification is the first basic step of biological nitrification and denitrification. In nitrification, the secondary effluent is introduced into another aeration tank, trickling filter, or biodisc. Because most of the carbonaceous BOD has already been removed, the microorganisms driving this advanced step are the nitrifying bacteria *Nitrosomonas* and *Nitrobacter*. In nitrification, the ammonia nitrogen is converted to nitrate nitrogen, producing a *nitrified effluent*. At this point, the nitrogen has not actually been removed, only converted to a form that is not toxic to aquatic life and that does not cause an

additional oxygen demand. Performance of the nitrification process can be limited by alkalinity, as it requires 7.3 parts alkalinity to 1.0 part ammonia nitrogen, as well as by pH, dissolved oxygen availability, toxicity (ammonia or other toxic materials), and process mean cell residence time (sludge retention time). As a general rule, biological nitrification is more effective and achieves higher levels of removal during the warmer times of the year.

4.5.1 Operational Considerations

Making sure that the nitrification process performs as per design requires the operator to monitor the process and to make routine adjustments. A loss of solids from the settling tank, rotating biological contactor (RBC), or trickling filter is a common problem that the operator must be able to identify and correct. In these instances, obviously, the operator needs to be familiar with activated sludge system, RBC, or trickling filter operations. The operator must also be familiar with other nitrification operational problems and must be able to take the proper corrective actions. We discuss typical nitrification operational problems and recommended corrective actions below.

- **Symptom 1.** Decreased pH with loss of nitrification

Causal factors: Insufficient alkalinity available for process; acid wastes in process influent

Corrective actions: If process alkalinity is less than 30 mg/L, add lime or sodium hydroxide to process influent; identify the source of and control acid wastes.

- **Symptom 2.** Incomplete nitrification

Causal factors: DO- or temperature-limited process; increased influent nitrogen loading; low nitrifying bacteria population; peak hourly ammonium concentrations exceeding available oxygen supplies

Corrective actions: Increase process aeration rate; decrease process nitrogen loading; increase nitrifying bacteria population; put additional units in service; modify operation to increase nitrogen removal; decrease wasting or solids loss; add settled raw sewage to nitrification unit to increase biological solids; increase oxygen supply; install flow equalization to minimize peaks.

- **Symptom 3.** Very high sludge volume index (>250) for nitrification sludge

Causal factor: Nitrification occurring in the first stage (BOD removal sludge)

Corrective actions: Transfer sludge from first to second stages; operate first stage at lower mean cell residence time or sludge retention time.

4.6 BIOLOGICAL DENITRIFICATION

Biological denitrification removes nitrogen from the wastewater. When bacteria come in contact with a nitrified element in the absence of oxygen, they reduce the nitrates to nitrogen gas, which escapes the wastewater. The denitrification process can be done in either an anoxic activated sludge system (suspended growth) or in a column system (fixed growth). The denitrification process can remove up to 85% or more of nitrogen. After effective biological treatment, little oxygen-demanding material is left in the wastewater when it reaches the denitrification process.

The denitrification reaction will only occur if an oxygen demand source exists when no dissolved oxygen is present in the wastewater. An oxygen demand source is usually added to reduce the nitrates quickly. The most common demand source added is soluble BOD or methanol. Approximately 3 mg/L of methanol is added for every 1 mg/L of nitrate nitrogen. Suspended growth denitrification reactors are mixed mechanically, but only enough to keep the biomass from settling without adding unwanted oxygen. Submerged filters of different types of media may also be used to provide denitrification. A fine media downflow filter is sometimes used to provide both denitrification and effluent filtration. A fluidized sand bed, where wastewater flows upward through a media of sand or activated carbon at a rate to fluidize the bed, may also be used. Denitrification bacteria grow on the media.

4.6.1 Operational Considerations

In operation of a denitrification process, operators monitor performance by observing various parameters and other indicators that can suggest process malfunction or suboptimal performance and the need for various corrective actions. We discuss several of these indicators and observations of poor process performance, their causal factors, and corrective actions in the following.

- **Symptom 1.** Sudden increase in effluent BOD₅

Causal factor: Excessive methanol or other organic matter present

Corrective actions: Reduce methanol addition; install automated methanol control system; install aerated stabilization unit for removal of excess methanol.

- **Symptom 2.** Sudden increase in effluent nitrate concentration

Causal factors: Inadequate methanol control; denitrification pH outside 7.0 to 7.5 range required for process; loss of solids from denitrification process due to pump failure; excessive mixing introducing dissolved oxygen

Corrective actions: Identify and correct the control problem; correct the pH problem in the nitrification process, and adjust the process influent pH; correct the denitrification sludge return; increase the denitrification sludge waste rate; decrease

the denitrification sludge waste rate; transfer sludge from carbonaceous units to the denitrification unit; reduce mixer speed; remove some mixers from service.

- **Symptom 3.** High head loss (packed bed nitrification)

Causal factors: Excessive solids in unit; nitrogen gas accumulating in unit

Corrective action: Backwash unit 1 to 2 minutes, then return to service.

- **Symptom 4.** Out-of-service packed bed unit binding on startup

Causal factor: Solids floating to the top during shutdown

Corrective action: Backwash units before removing them from service and immediately before placing them in service.

4.7 CARBON ADSORPTION

The main purpose of carbon adsorption in advanced treatment processes is the removal of refractory organic compounds (non-BOD₅) and soluble organic material that are difficult to eliminate by biological or physicochemical treatment. In the carbon adsorption process, wastewater passes through a container filled with either carbon powder or carbon slurry. Organics adsorb onto the carbon (i.e., organic molecules are attracted to the activated carbon surface and are held there) with sufficient contact time. A carbon system usually has several columns or basins used as contactors. Most contact chambers are either the open concrete gravity-type systems or steel pressure containers applicable to either upflow or downflow operation. With use, carbon loses its adsorptive capacity. The carbon must then be regenerated or replaced with fresh carbon. As head loss develops in carbon contactors, they are backwashed with clean effluent in much the same way that effluent filters are backwashed. Carbon used for adsorption may be in a granular form or in a powdered form.

Note: Powdered carbon is too fine for use in columns; it is usually added to the wastewater and then later removed by coagulation and settling.

4.7.1 Operational Considerations

With regard to the carbon adsorption system for advanced wastewater treatment, operators are primarily interested in monitoring the system to prevent excessive head loss, to reduce levels of hydrogen sulfide in the carbon contactor, to ensure that the carbon is not fouled, and to minimize corrosion of metal parts and damage to concrete in contactors.

- **Symptom 1.** Excessive head loss

Casual factors: Highly turbid influent; growth and accumulation of biological solids in unit; excessive carbon fines due to deterioration during handling; plugged inlet or outlet screens

Corrective actions: Backwash unit vigorously; correct the problem in prior treatment steps; operate as an expanded upflow bed to remove solids continuously; increase frequency of backwashing for downflow beds; improve soluble BOD₅ removal in prior treatment steps; remove carbon from the unit and wash out fines; replace carbon with harder carbon; backflush screens.

- **Symptom 2.** Hydrogen sulfide in carbon contactor

Causal factors: Low or no dissolved oxygen or nitrate in the contactor influent; high influent BOD₅ concentrations; excessive detention time in carbon contactor

Corrective actions: Add air, oxygen, or sodium nitrate to unit influent; improve soluble BOD₅ removal in prior treatment steps; precipitate sulfides already formed with iron on chlorine; reduce detention time by removing contactors from service; backwash units more frequently and more vigorously, using air scour or surface wash.

- **Symptom 3.** Large decrease in chemical oxygen demand (COD) removed per pound of carbon regenerated

Causal factor: Fouled and less efficient carbon

Corrective action: Improve regeneration process performance.

- **Symptom 4.** Corrosion of metal parts and damage to concrete in contactors

Causal factors: Hydrogen sulfide in carbon contactors; holes in protective coatings exposed to dewatered carbon

Corrective actions: See corrective actions in Symptom 2; repair protective coatings.

4.8 LAND APPLICATION

The application of secondary effluent onto a land surface can provide an effective alternative to the expensive and complicated advanced treatment methods discussed previously and the biological nutrient removal (BNR) system discussed later. A high-quality polished effluent (i.e., effluent with high levels of TSS, BOD, phosphorus, and nitrogen compounds as well as reduced refractory organics) can be obtained by the natural processes that occur as the effluent flows over the vegetated ground surface and percolates through the soil. Certain limitations are involved with the land application of wastewater effluent; for example, the process requires large land areas. Soil type and climate are also critical factors in controlling the design and feasibility of a land treatment process.

4.8.1 Types and Modes of Land Application

Three basic types or modes of land application or treatment are commonly used: *irrigation* (slow rate), *overland flow*, and *infiltration-percolation* (rapid rate). The basic objectives of these types of land

applications and the conditions under which they can function vary. In irrigation (also called *slow-rate*), wastewater is sprayed or applied to the surface of the land, usually by ridge-and-furrow surface spreading or by sprinkler systems. Wastewater enters the soil. Crops growing on the irrigation area utilize available nutrients. Soil organisms stabilize the organic content of the flow. Water returns to the hydrologic (water) cycle through evaporation or by entering the surface water or groundwater.

The irrigation land application method provides the best results (compared with the other two types of land application systems) with respect to advanced treatment levels of pollutant removal. Not only are suspended solids and BOD significantly reduced by filtration of the wastewater, but also biological oxidation of the organics in the top few inches of soil occurs. Nitrogen is removed primarily by crop uptake, and phosphorus is removed by adsorption within the soil. Expected performance levels for irrigation include:

BOD ₅	98%
Suspended solids	98%
Nitrogen	85%
Phosphorus	95%
Metals	95%

The overland flow application method utilizes physical, chemical, and biological processes as the wastewater flows in a thin film down the relatively impermeable surface. In the process, wastewater sprayed over sloped terraces flows slowly over the surface. Soil and vegetation remove suspended solids, nutrients, and organics. A small portion of the wastewater evaporates. The remainder flows to collection channels. Collected effluent is discharged to surface waters. Expected performance levels for overland flow include:

BOD ₅	92%
Suspended solids	92%
Nitrogen	70–90%
Phosphorus	40–80%
Metals	50%

In the infiltration–percolation application method, wastewater is sprayed or pumped to spreading basins (also referred to as *recharge basins* or *large ponds*). Some wastewater evaporates. The remainder percolates or infiltrates into the soil. Solids are removed by filtration. Water recharges the groundwater system. Most of the effluent percolates to the groundwater; very little of it is absorbed by vegetation. The filtering and adsorption action of the soil removes most of the BOD, TSS, and phosphorus from the effluent; however, nitrogen removal is relatively poor. Expected performance levels for infiltration–percolation include:

BOD ₅	85–99%
Suspended solids	98%
Nitrogen	0–50%
Phosphorus	60–95%
Metals	50–95%

4.8.2 Operational Considerations

Performance levels are dependent on the land application process used. To be effective, operators must monitor the operation of the land application process employed. Experience has shown that these processes can be very effective, but problems exist when the flow contains potentially toxic materials that may become concentrated in the crops being grown on land. Along with this problem, other problems are common, including ponding, deterioration of distribution piping systems, malfunctioning sprinkler heads, waste runoff, irrigated crop die-off, poor crop growth, and too much flow rate.

- **Symptom 1.** Ponding water in irrigated areas

Causal factors: Excessive application rate; inadequate drainage because of groundwater levels; damaged drainage wells; inadequate well withdrawal rates; damaged drain tiles; broken pipe in distribution system

Corrective actions: Reduce the application rate to an acceptable level; irrigate in portions of the site where groundwater is not a problem; store wastewater until the condition is corrected; repair drainage wells; increase drainage well pumping rates; repair damaged drain tiles; repair pipe.

- **Symptom 2.** Deterioration of distribution piping

Causal factors: Effluent remaining in pipe for long periods; different metals being used in the same line

Corrective actions: Drain pipe after each use; coat steel valves; install cathodic/anodic protection.

- **Symptom 3.** No flow from source sprinkler nozzles

Causal factor: Nozzles clogged

Corrective action: Repair or replace the screen on the irrigation pump inlet.

- **Symptom 4.** Wastes running off irrigation area

Causal factors: Impermeable clay soil due to a high sodium adsorption ratio (SAR); solids sealing soil surface; application rate greater than soil infiltration rate; break in distribution piping; decreased soil permeability due to continuous application of wastewater; rain-saturated soil

Corrective actions: Feed calcium and magnesium to maintain sodium adsorption ratio at less than 9; strip crop area; reduce application rate to an acceptable level; repair the system; allow 2- to 3-day rest period between each application; store wastewater until the soil has drained.

- **Symptom 5.** Dead irrigated crop

Causal factors: Too much or not enough water applied; toxic materials in wastewater at toxic concentrations; excessive application of insecticide or herbicide; root zone of crop flooded due to inadequate drainage

Corrective actions: Adjust the application rate to an appropriate level; eliminate the source of toxicity; apply only as permitted or directed.

- **Symptom 6.** Poor crop growth

Causal factors: Too little nitrogen or phosphorus; nutrient applications not timed to coincide with plant nutrient need

Corrective actions: Increase application rate to supply nitrogen and phosphorus; augment nitrogen and phosphorus of the wastewater with commercial fertilizer applications; adjust the application schedule to match crop need.

- **Symptom 7.** Normal psi in irrigation pump and above-average flow rate

Causal factors: Broken main, riser, or lateral; leaking gasket; missing sprinkler head or nozzle; too many distribution laterals in service at one time

Corrective actions: Locate and repair problems; locate and replace defective gasket; correct valving to adjust number of laterals in service.

- **Symptom 8.** Above-average psi in irrigation pump and below-average flow rate

Causal factor: Blockage in system

Corrective action: Locate and correct blockage.

- **Symptom 9.** Below-average psi in irrigation pump and below-average flow rate

Causal factors: Worn impeller; partially clogged pump inlet screen

Corrective actions: Replace impeller; clean screen.

- **Symptom 10.** Excessive erosion occurring

Causal factors: Excessive application rates; inadequate crop coverage

Coverage actions: Reduce application rate.

- **Symptom 11.** Odor complaints

Causal factors: Wastes turning septic during transport to treatment/irrigation site; septic storage reservoirs

Corrective actions: Aerate or chemically treat wastes during transport; install cover over discharge point; collect and treat gases before release; improve pretreatment; aerate storage reservoirs.

- **Symptom 12.** Center pivot irrigation rigs stuck in mud

Causal factors: Excessive application rates; improper rig or tires; poor drainage

Corrective actions: Reduce application rate; install tires with higher flotation capabilities.

- **Symptom 13.** Increasing nitrate in groundwater near the irrigation site

Causal factors: Nitrogen application rate not balanced with crop need; applications occurring during dormant periods; crop not being properly harvested and removed

Corrective actions: Change to crops with higher nitrogen requirements; adjust the schedule to apply only during active growth periods; harvest and remove crop as required.

4.9 BIOLOGICAL NUTRIENT REMOVAL

Recent experience has shown that biological nutrient removal (BNR) systems are reliable and effective in removing nitrogen and phosphorus. The process is based on the principle that, under specific conditions, microorganisms will remove more phosphorus and nitrogen than is required for biological activity; thus, treatment can be accomplished without the use of chemicals. Not having to purchase and use chemicals to remove nitrogen and phosphorus has numerous potential cost-benefit implications. In addition, because chemicals are not used, chemical waste products are not produced, thus reducing the need to handle and dispose of waste. Several patented processes are available for this purpose. Performance depends on the biological activity and the process employed.

4.10 ENHANCED BIOLOGICAL NUTRIENT REMOVAL

Removing phosphorus from wastewater in secondary treatment processes has evolved into innovative enhanced biological nutrient removal (EBNR) technologies. An EBNR treatment process promotes the production of phosphorus-accumulating organisms, which utilize more phosphorus in their metabolic processes than a conventional secondary biological treatment process (USEPA, 2007). The average total phosphorus concentrations in raw domestic wastewater are usually between 6

and 8 mg/L, and the total phosphorus concentration in municipal wastewater after conventional secondary treatment is routinely reduced to 3 or 4 mg/L. EBNR incorporated into the secondary treatment system can often reduce the total phosphorus concentrations to 0.3 mg/L or less. Facilities using EBNR significantly reduce the amount of phosphorus to be removed through subsequent chemical addition and tertiary filtration processes. This improves the efficiency of the tertiary process and significantly reduces the costs of chemicals used to remove phosphorus. Facilities using EBNR report that their chemical dosing has been cut in half after EBNR was installed to remove phosphorus (USEPA, 2007).

Treatment provided by these EBNR processes also reduces or removes other pollutants that commonly affect water quality. Biochemical oxygen demand and total suspended solids are routinely reduced to less than 2 mg/L and fecal coliform bacteria to less than 10 fcu/100 mL. Turbidity of the final effluent is very low, which allows for effective disinfection using ultraviolet light rather than chlorination. Recent studies report finding that wastewater treatment facilities using EBNR also significantly reduce the amount of pharmaceuticals and healthcare products in municipal wastewater, as compared to removal accomplished by conventional secondary treatment. The following text describes some of the EBNR treatment technologies currently being used in the United States.

4.10.1 0.5-MGD Capacity Plant

- *Advanced phosphorus treatment technology*—Chemical addition, two-stage filtration
- *Treatment process description (liquid only)*—Grit removal and screening; extended aeration and secondary clarification (in combined aeration basin/clarifier); chemical addition for flocculation using polyaluminum silicate sulfate (PASS) and filtration through two-stage DynaSand® filters

4.10.2 1.5-MGD Capacity Plant

- *Advanced phosphorus treatment technology*—BNR, chemical addition, tertiary settlers, filtration
- *Treatment process description (liquid only)*—Grit removal and screening in the headworks; activated sludge biological treatment; biological aerated filter (IDI BioFor™ for nitrification); chemical coagulation using alum; flocculation and clarification using tube settler (IDI Densadeg™); filtration (single-stage Parkson DynaSand® filters); disinfection and dechlorination

The DynaSand® filter reject rate is reported to be about 15 to 20%. The DynaSand® filters are configured in four two-cell units for a total of eight filters beds, each of which is 8 feet deep. Influent concentrations of total phosphorus are typically measured at about 6 mg/L (very

typical value for untreated domestic wastewater). The aeration basins are operated with an anoxic zone to provide for biological removal of phosphorus. About 60% of the influent phosphorus is removed through the biological treatment process. Sodium sulfate is added to maintain alkalinity throughout the treatment process for phosphorus removal. Approximately 100 to 120 mg/L sodium sulfate is applied to the wastewater just upstream of where alum is added. Alum is used to precipitate phosphorus. The alum dose is typically 135 mg/L and is used with 0.5 to 1.0 mg/L cationic polymer.

Note: The DynaSand® filter is a continuous backwash, upflow, deep-bed, granular media filter.

4.10.3 1.55-MGD Capacity Plant

- *Advanced phosphorus treatment technology*—Chemical addition; two-stage filtration
- *Treatment process description (liquid only)*—Grit removal and screening; extended aeration and secondary clarification; chemical addition for flocculation using aluminum chloride added to the wastewater at both the secondary clarifiers and the distribution header for the DynaSand® filters; filtration through two-stage DynaSand® filters; disinfection with chlorine and dechlorination with sulfur dioxide

Chlorine is added to the filter influent to control biological growth in the filters.

4.10.4 2-MGD Capacity Plant

- *Advanced phosphorus treatment technology*—BNR; chemical addition; two-stage filtration
- *Treatment process description (liquid only)*—Grit removal and screening; BNR activated sludge (five-stage BardenPho™ process: anaerobic basin, anoxic basin, oxidation ditch aeration basin, anoxic basin, reaeration basin); clarifiers (two parallel rectangular); chemical addition using alum and polymer; effluent polishing and filtration using four USFilter's Memcor™ filter modules; ultraviolet disinfection

The USFilter units utilize two-stage filtration in which the first stage is upflow through a plastic media with air scour. The second stage filtration is through a downflow, mixed media with backwash cleaning. The concentration of alum used for coagulation is 95 mg/L.

4.10.5 2.6-MGD Capacity Plant

- *Advanced phosphorus treatment technology*—BNR; chemical addition; tertiary settlers and filtration

- *Treatment process description (liquid only)*—Grit removal and screening; aeration basins; secondary clarification; chemical coagulation and flocculation using alum and polymer; tertiary clarification (rectangular conventional with plate settlers); mixed-media bed filters (5 feet deep); disinfection (the filtration process removes enough fecal coliform so conventional disinfection is not normally required)

The average alum dose is 70 mg/L in the wastewater but varies from 50 to 180 mg/L. A greater dose of alum is applied during the winter period. The polymer dose concentration is about 0.1 mg/L.

4.10.6 3-MGD Capacity Plant

- *Advanced phosphorus treatment technology*—BNR; chemical addition; tertiary settlers and filtration
- *Treatment process description (liquid only)*—Grit removal and screening; biological nutrient removal; chemical coagulation and flocculation using polymer and alum; clarification via tube settlers; filtration through mixed-media bed filters; disinfection with chlorine and dechlorination using sodium bisulfate

4.10.7 4.8-MGD Capacity Plant

- *Advanced phosphorus treatment technology*—Multiple-point chemical addition; tertiary settling and filtration
- *Treatment process description (liquid only)*—Grit removal and screening; primary clarification; trickling filters; intermediate clarification (with polymer addition to aid settling); rotating biological contactors; secondary clarification; chemical addition using poly-aluminum chloride; filtration through mixed-media traveling bed filters; ultraviolet disinfection

The final effluent is discharged down a cascading outfall to achieve reaeration prior to mixing in the receiving water. Approximately 1 million gallons per day of final effluent is utilized by the local power company for cooling water.

4.10.8 24-MGD Capacity Plant

- *Advanced phosphorus treatment technology*—BNR; chemical addition; filtration
- *Treatment process description (liquid only)*—Grit removal and screening; primary clarification; biological treatment with enhanced biological nutrient removal; secondary clarification; chemical addition of alum and polymer for phosphorus removal; tertiary clarification; filtration through dual-media, gravity-bed filters and disinfection

Lime is added to the biological process to maintain the proper pH and alkalinity. A two-stage fermenter is operated to produce volatile fatty acids, which are added to the biological contact basin. The enhanced biological nutrient removal process at times reduces total phosphorus to levels below the 0.11-mg/L permit limitation; however, this performance is not achieved during the entire period when the seasonal phosphorus limitations are in effect. The tertiary treatment with chemical addition and filtration provides assurance that the final effluent is of consistently good quality. Some of the treated effluent is reclaimed for irrigation.

4.10.9 39-MGD Capacity Plant

- *Advanced phosphorus treatment technology*—Chemical addition; filtration
- *Treatment process description (liquid only)*—Grit removal and screening; alum addition; primary clarification; extended aeration; secondary clarification; flocculation using alum and polymer; tertiary clarification; filtration; disinfection with chlorine; dechlorination

Wastewater is treated in two separate trains. Four 60-foot-diameter ClariCone® tertiary clarifiers are used on one treatment train to provide contact with 6 monomedia anthracite gravity-flow bed filters. The other treatment train uses conventional clarifiers for tertiary settling followed by filtration through four dual-media, gravity-bed filters. Phosphorus is removed in four locations within this system: alum-enhanced removal in the primary clarifiers, biological nutrient removal in the aeration basins, chemical flocculation and removal in the tertiary clarifiers, and removal through filtration.

4.10.10 42-MGD Capacity Plant

- *Advanced phosphorus treatment technology*—Chemical addition (high lime); tertiary filtration
- *Treatment process description (liquid only)*—Conventional treatment that removes 90% of most incoming pollutants; grit removal and screening; primary clarification; aerobic biological selectors; activated sludge aeration basins with nitrification/denitrification processes; secondary clarification

A chemical advanced treatment (high lime process) is used to reduce phosphorus to below 0.10 mg/L, to capture organics from secondary treatment, to precipitate heavy metals, and to serve as a barrier to viruses. Lime slurry is added to the rapid-mix basins to achieve a pH of 11, and anionic polymer is added to the flocculation basins. Other elements of treatment include chemical clarification, first-stage recarbonation to lower the pH to 10, recarbonation clarifiers to collect precipitated calcium carbonate, second-stage recarbonation to lower the pH to 7, and storage in ballast ponds. Physical advanced treatment to meet stringent

limits for TSS (1 mg/L) and COD (10 mg/L) include alum or polymer addition, multimedia filters, and activated carbon contactors. Disinfection is achieved through chlorination and dechlorination.

4.10.11 54-MGD Capacity Plant

- *Advanced phosphorus treatment technology*—BNR; multiple-point chemical addition; tertiary settling and filtration
- *Treatment process description (liquid only)*—Grit removal and screening; primary settling with the possible addition of ferric chloride and polymer; adding methanol or volatile fatty acid to biological reactor basins to aid BNR; ferric chloride and polymer addition prior to secondary settling; alum addition and mixing; tertiary clarification with inclined plate settlers; dual-media, gravity-bed filtration; ultraviolet disinfection and post-aeration

4.10.12 67-MGD Capacity Plant

- *Advanced phosphorus treatment technology*—BNR; chemical addition; tertiary clarification and filtration
- *Treatment process description (liquid only)*—Screening; primary clarification; biological treatment with enhanced biological nutrient removal; polymer addition as needed; secondary clarification; equalization and storage in retention ponds; tertiary clarification with ferric chloride addition to remove phosphorus; disinfection with sodium hypochlorite; filtration through dual-/single-media, gravity-bed filters.

REFERENCE AND RECOMMENDED READING

Spellman, F.R. (2008). *Handbook of Water and Wastewater Treatment Plant Operations*, 2nd ed. Boca Raton, FL: CRC Press.

USEPA. (2007). *Advanced Wastewater Treatment to Achieve Low Concentration of Phosphorus*. Washington, D.C.: U.S. Environmental Protection Agency.

ADVANCED WASTEWATER CALCULATIONS

5.1 INTRODUCTION

Many of the numerous suggestions and recommendations from users of all three volumes of the first edition of *Spellman's Standard Handbook for Wastewater Operators* have been incorporated into the second edition. For use as a study guide for operator licensure, the number one recommendation was to add more math. Users and reviewers pointed out that wastewater operators must perform various mathematical calculations as part of their assigned plant operations. Moreover, all levels of the licensure exams require test takers to work through a variety of operator math problems. In light of this and to stay current with applicable requirements, we have added more than 500 real-world (actual) wastewater calculations in this chapter. Many of these calculations are difficult or complex and require thorough knowledge of math operations to complete correctly. Try to work as many as you can without referring to Appendix A for the correct solution. When complete, check your answer against the solutions in Appendix A. For those questions answered incorrectly, work them again. Remember, practice makes perfect.

5.2 WASTEWATER COLLECTION AND PRELIMINARY TREATMENT

Note: All answers are rounded to appropriate value.

- 5.1 An empty screenings hopper 4.3 ft by 5.8 ft is filled to an even depth of 28 in. over the course of 96 hr. If the average plant flow rate was 4.9 MGD during this period, how many cubic feet of screenings were removed per million gallons of wastewater received?
- 5.2 A grit channel has a water depth of 1.4 ft and width of 1.7 ft. The flow rate through the channel is 700 gpm. What is the velocity through the channel in feet per second?
- 5.3 A grit channel has a water depth of 16 in. and a width of 18 in. The flow rate through the channel is 1.2 MGD. What is the velocity through the channel in feet per second?
- 5.4 What is the gallon capacity of a wet well 12 ft long, 10 ft wide, and 6 ft deep?
- 5.5 A wet well is 14 ft long by 12 ft wide and contains water to a depth of 6 ft. How many gallons of water does it contain?
- 5.6 What is the cubic feet capacity of a wet well 9 ft by 9 ft with a maximum depth of 6 ft?
- 5.7 The maximum capacity of a wet well is 4850 gal. If the wet well is 12 ft long and 8 ft wide, what is the maximum depth of water in the wet well?
- 5.8 A wet well is 10 ft long by 8 ft wide. If the wet well contains water to a depth of 3.1 ft, what is the volume of water in the wet well in gallons?

5.2.1 Wet-Well Pumping Rate

- 5.9 A wet well is 10 ft by 10 ft. During a 5-minute pumping test, with no influent to the well, a pump lowers the water level 1.8 ft. What is the pumping rate in gallons per minute?
- 5.10 A wet well is 12 ft by 12 ft. During a 3-minute pumping test with no influent inflow a pump lowers the water level 1.3 ft. What is the pumping rate in gallons per minute?
- 5.11 The water level in a wet well drops 17 in. during a 3-minute pumping test. There was no influent to the wet well during the pumping test. If the wet well is 9 ft by 7 ft, what is the pumping rate in gallons per minute?
- 5.12 During a period when there is no pumping from the wet well, the water level rises 0.9 ft in 1 minute. If the wet well is 9 ft long by 8 ft wide, what is the flow rate in gallons per minute of wastewater entering the wet well?
- 5.13 A lift station wet well is 12 ft by 14 ft. For 5 minutes the influent valve is closed and the well level drops 2.2 ft. What is the pumping rate in gallons per minute?
- 5.14 The influent valve to a 12-ft by 14-ft station wet well is closed for 4 minutes. During this time the well level dropped 1.9 ft. What is the pump discharge in gallons per minute?

- 5.15 The dimensions of the wet well for a lift station is 10 ft-9 in. by 12 ft-2 in. The influent valve to the well is closed only long enough for the level to drop 2 ft. The time to accomplish this was 5 minutes and 30 seconds. At what rate, in gallons per minute, is the pump discharging?
- 5.16 A lift station wet well is 11.8 ft by 14 ft. The influent flow to this well is 410 gpm. If the well level rises 1 in. in 8 minutes, how many gallons per minute is the pump discharging?
- 5.17 A lift station wet well is 140 in. by 148 in. The influent flow to this well is 430 gpm. If the well level drops 1.5 in. in 5 minutes, how many gallons per minute is the pump discharging?
- 5.18 A lift station wet well is 9.8 ft by 14 ft and has an influent rate of 800 gpm. The level in the well drops 8 in. in 15 minutes with two pumps in operation. If the first pump discharges at a rate of 500 gpm, at what pumping rate is the second pump discharging?

5.2.2 Screenings Removed

- 5.19 A total of 60 gal of screenings is removed from the wastewater flow during a 24-hr period. What is the screenings removal reported as cubic feet per day?
- 5.20 In one week, 282 gal of screenings were removed from the wastewater screens. What was the average screenings removal in cubic feet per day?
- 5.21 The flow at a treatment plant is 3.33 MGD. If 4.9 ft³ of screenings are removed during a 24-hr period, what is the screenings removal reported as cubic feet per million gallons?
- 5.22 On a particular day, a treatment plant receives a flow of 4.9 MGD. If 81 gal of screenings are removed that day, what is the screenings removal expressed as cubic feet per million gallons?
- 5.23 A total of 48 gal of screenings is removed from the treatment plant during a 24-hr period. If the treatment plant received a flow of 2,280,000 gpd, what is the screenings removal expressed as cubic feet per million gallons?

5.2.3 Screening Pit Capacity

- 5.24 A screenings pit has a capacity of 600 ft³. If an average of 2.9 ft³ of screenings are removed daily from the wastewater flow, in how many days will the pit be full?
- 5.25 A screenings pit has a capacity of 9 yd³ available for screenings. If the plant removes an average of 1.6 ft³ of screenings per day, in how many days will the pit be filled?
- 5.26 A plant has been averaging a screenings removal of 2.6 ft³/MG. If the average daily flow is 2.9 MGD, how many days will it take to fill a screenings pit with an available capacity of 292 ft³?

- 5.27 Suppose you want to use a screenings pit for 120 days. If the screenings removal rate is $3.5 \text{ ft}^3/\text{day}$, what is the required screenings pit capacity in cubic feet?

5.2.4 Grit Channel Velocity

- 5.28 A grit channel is 4 ft wide, with water flowing to a depth of 18 in. If the flow meter indicates a flow rate of 1820 gpm, what is the velocity of flow through the channel in feet per second?
- 5.29 A stick in a grit channel travels 26 ft in 32 seconds. What is the estimated velocity in the channel in feet per second?
- 5.30 The total flow through both channels of a grit channel is 4.3 cfs. If each channel is 3 ft wide and water is flowing to a depth of 14 in., what is the velocity of flow through the channel in feet per second?
- 5.31 A stick is placed in a grit channel and flows 36 ft in 32 seconds. What is the estimated velocity in the channel in feet per second?
- 5.32 The depth of water in a grit channel is 16 in. The channel is 34 in. wide. If the flow meter indicates a flow of 1140 gpm, what is the velocity of flow through the channel in feet per second?

5.2.5 Grit Removal

- 5.33 A treatment plant removes 12 ft^3 of grit in one day. If the plant flow was 8 MGD, what is this removal expressed as cubic feet per million gallons?
- 5.34 The total daily grit removal for a plant is 260 gal. If the plant flow is 11.4 MGD, how many cubic feet of grit are removed per MG flow?
- 5.35 The average grit removal at a particular treatment plant is $3.1 \text{ ft}^3/\text{MG}$. If the monthly average daily flow is 3.8 MGD, how many cubic yards of grit would be removed from the wastewater flow during one 30-day month?
- 5.36 The monthly average grit removal is $2.2 \text{ ft}^3/\text{MG}$. If the average daily flow for the month is 4,230,000 gpd, how many cubic yards must be available for grit disposal if the disposal pit is to have a 90-day capacity?
- 5.37 A grit channel 2.6 ft wide has water flowing to a depth of 16 in. If the velocity through the channel is 1.1 fps, what is the flow rate in cubic feet per second through the channel?
- 5.38 A grit channel 3 ft wide has water flowing at a velocity of 1.4 fps. If the depth of the water is 14 in., what is the flow rate through the channel in gallons per day?
- 5.39 A grit channel 32 in. wide has water flowing to a depth of 10 in. If the velocity of the water is 0.90 fps, what is the flow rate in the channel in cubic feet per second?

5.2.6 Plant Loadings

- 5.40 A suspended solids test was done on a 50-mL sample. The weight of the crucible and filter before the test was 25.6662 g. After the sample was filtered and dried, the weight of the cooled crucible was 25.6782 g. What was the concentration of suspended solids in milligrams per liter?
- 5.41 A 26.2345-g crucible was used to filter 26 mL of raw influent sample for a suspended solids test. The dried crucible weighed 26.2410 g. What was the concentration of suspended solids in milligrams per liter?
- 5.42 A BOD test on a 6-mL sample showed an initial DO of 8.42 mg/L for the sample and dilution water. The DO of the sample after 5 days of incubation was 4.28 mg/L. What was the BOD of the sample?
- 5.43 A BOD test on a 5-mL sample showed an initial DO of 7.96 mg/L for the sample and dilution water. The DO of the sample after 5 days of incubation was 4.26 mg/L. What was the BOD of the sample?
- 5.44 A wastewater treatment plant receives a flow of 3.13 MGD with a total phosphorus concentration of 14.6 mg/L. How many pounds of phosphorus per day is that?
- 5.45 Raw influent BOD is 310 mg/L. If the influent flow rate is 6.15 MGD, at what rate are the pounds of BOD entering the plant?
- 5.46 The plant's influent flow rate of 4.85 MGD has a suspended solids concentration of 188 mg/L. How many pounds of suspended solids enter daily?
- 5.47 A plant has been averaging a screenings removal of 2.6 ft³/MG. If the average daily flow is 2,950,000 gpd, how many days will it take to fill a screenings pit that has an available capacity of 270 ft³?
- 5.48 In 7 days, a total of 210 gal of screenings was removed from the wastewater screens. What was the average screenings removal in cubic feet per day?
- 5.49 A total of 5.4 ft³ of screenings was removed from the wastewater flow during a 24-hr period. If the flow at the treatment plant is 2,910,000 gpd, what is the screenings removal reported as cubic feet per million gallons?
- 5.50 A screenings pit has a capacity of 12 cubic yards available for screenings. If the plant removes an average of 2.4 ft³ of screenings per day, in how many days will the pit be filled?
- 5.51 A float is placed in a channel. If the float travels 36 ft in 30 seconds, what is the estimated velocity in the channel in feet per second?
- 5.52 A grit channel 2.6 ft wide has water flowing to a depth of 15 in. If the velocity of the water is 0.8 fps, what is the flow in the channel in cubic feet per second?
- 5.53 The total daily grit removal for a treatment plant is 210 gal. If the plant flow is 8.8 MGD, how many cubic feet of grit are removed per million gallons of flow?

- 5.54 A grit channel is 2.6 ft wide with water flowing to a depth of 15 in. If the flow velocity through the channel is 1.8 fps, what is the flow through the clarifier in gallons per minute?
- 5.55 The average grit removal at a particular treatment plant is 2.3 ft³/MG. If the monthly average daily flow is 3,610,000 gpd, how many cubic yards of grit would be expected to be removed from the wastewater flow during a 30-day month?
- 5.56 A grit channel 3 ft wide has water flowing to a depth of 10 in. If the velocity through the channel is 1 fps, what is the flow rate through the channel in cubic feet per second?

5.3 SEDIMENTATION

- 5.57 A circular clarifier has a capacity of 160,000 gal. If the flow through the clarifier is 1,810,000 gpd, what is the detention time for the clarifier in hours?
- 5.58 Flow to a sedimentation tank 90 ft long, 25 ft wide, and 10 ft deep is 3.25 MGD. What is the detention time in the tank in hours?
- 5.59 A circular clarifier receives a steady, continuous flow of 4,350,000 gpd. If the clarifier is 90 ft in diameter by 12 ft deep, what is the clarifier detention time in hours?

5.3.1 Primary Treatment

- 5.60 The influent flow rate to a primary settling tank is 2.01 MGD. The tank is 84 ft in length and 20 ft wide and has a water depth of 13.1 ft. What is the detention time of the tank in hours?
- 5.61 A primary settling tank 90 ft long, 20 ft wide, and 14 ft deep receives a flow rate of 1.45 MGD. What is the surface overflow rate in gallons per day per square foot?
- 5.62 A primary sludge sample is tested for total solids. The dish alone weighed 22.20 g. The sample with the dish weighed 73.86 g. After drying, the dish with dry solids weighed 23.10 g. What was the percent total solids (%TS) of the sample?
- 5.63 Primary sludge is pumped to a gravity thickener at 390 gpm. The sludge concentration is 0.8%. How many pounds of solids are pumped daily?
- 5.64 The raw influent suspended solids concentration is 140 mg/L. The primary effluent concentration of suspended solids is 50 mg/L. What percentage of the suspended solids is removed by primary treatment?
- 5.65 A primary tank with a total weir length of 80 ft receives a flow rate of 1.42 MGD. What is the weir overflow rate in gallons per day per foot?
- 5.66 A wastewater treatment plant has 8 primary tanks. Each tank is 80 ft long by 20 ft wide with a side water depth of 12 ft and a total weir length of 86 ft. The flow rate to the plant is 5 MGD. There

are currently 3 tanks in service. Calculate the detention time in minutes, the surface overflow rate in gallons per day per square foot, and the weir overflow rate in gallons per day per foot.

- 5.67 Flow to a sedimentation tank 80 ft long, 35 ft wide, and 12 ft deep is 3.24 MGD. What is the detention time in the tank in hours?

5.3.2 Weir Overflow Rate

- 5.68 A rectangular clarifier has a total of 112 ft of weir. What is the weir overflow rate in gallons per day per foot when the flow is 1,520,000 gpd?
- 5.69 A circular clarifier receives a flow of 2.98 MGD. If the diameter of the weir is 70 ft, what is the weir overflow rate in gallons per day per foot?
- 5.70 Average flow to a clarifier is 2520 gpm. If the diameter of the wire is 90 ft, what is the weir overflow rate in gallons per day per foot?
- 5.71 The total feet of weir for a clarifier is 192 ft. If the flow to the weir is 1.88 MGD, what is the weir overflow rate in gallons per day per foot?

5.3.3 Surface Overflow Rate

- 5.72 A circular clarifier has a diameter of 70 ft. If the primary clarifier influent flow is 2,910,000 gpd, what is the surface overflow rate in gallons per day per square foot?
- 5.73 A sedimentation basin 80 ft by 30 ft receives a flow of 2.35 MGD. What is the surface overflow rate in gallons per day per square foot?
- 5.74 A sedimentation tank is 80 ft long by 30 ft wide. If the flow to the tank is 2,620,000 gpd, what is the surface overflow rate in gallons per day per square foot?
- 5.75 The average flow to a secondary clarifier is 2610 gpm. What is the surface overflow rate in gallons per day per square foot if the secondary clarifier has a diameter of 60 ft?

5.3.4 Solids Loading Rate

- 5.76 A secondary clarifier is 70 ft in diameter and receives a combined primary effluent and return activated sludge flow of 4.1 MGD. If the MLSS concentration in the aeration tank is 3110 mg/L, what is the solids loading rate on the secondary clarifier in pounds per day per square foot?
- 5.77 A secondary clarifier, 80 ft in diameter, receives a primary effluent flow of 3.3 MGD and a return sludge flow of 1.1 MGD. If the MLSS concentration is 3220 mg/L, what is the solids loading rate on the clarifier in pounds per day per square foot?

- 5.78 The MLSS concentration in an aeration tank is 2710 mg/L. The 70-ft-diameter secondary clarifier receives a combined primary effluent and return activated sludge flow of 3,220,000 gpd. What is the solids loading rate on the secondary clarifier in pounds per day suspended solids per square foot?
- 5.79 A secondary clarifier, 80 ft in diameter, receives a primary effluent flow of 2,320,000 gpd and a return sludge flow of 660,000 gpd. If the MLSS concentration is 3310 mg/L, what is the solids loading rate on the clarifier in pounds per day per square foot?

5.3.5 BOD and SS Removed (lb/day)

- 5.80 If 125 mg/L suspended solids are removed by a primary clarifier, how many pounds per day suspended solids are removed when the flow is 5,550,000 gpd?
- 5.81 The flow to a primary clarifier is 2,920,000 gpd. If the influent to the clarifier has a suspended solids concentration of 240 mg/L and the primary effluent has 200 mg/L suspended solids, how many pounds per day suspended solids are removed by the clarifier?
- 5.82 The flow to a secondary clarifier is 4.44 MGD. If the influent BOD concentration is 200 mg/L and the effluent concentration is 110 mg/L, how many pounds of BOD are removed daily?
- 5.83 The flow to a primary clarifier is 980,000 gpd. If the influent to the clarifier has a suspended solids concentration of 320 mg/L and the primary effluent has a suspended solids concentration of 120 mg/L, how many pounds per day suspended solids are removed by the clarifier?

5.3.6 Unit Process Efficiency Calculations

- 5.84 The concentration of suspended solids entering a primary clarifier is 220 mg/L. If the suspended solids concentration in the primary clarifier effluent is 85 mg/L, what is the suspended solids removal efficiency of the primary clarifier?
- 5.85 The concentration of suspended solids entering a primary clarifier is 188 mg/L. If the suspended solids concentration in the primary clarifier effluent is 77 mg/L, what is the suspended solids removal efficiency of the primary clarifier?
- 5.86 The influent to a primary clarifier has a BOD content of 280 mg/L. If the primary clarifier effluent has a BOD concentration of 60 mg/L, what is the BOD removal efficiency of the primary clarifier?
- 5.87 The BOD concentration of a primary clarifier is 300 mg/L. If the primary clarifier effluent BOD concentration is 189 mg/L, what is the BOD removal efficiency of the primary clarifier?

5.3.7 General Sedimentation Calculations

- 5.88 The flow to a circular clarifier is 4,120,000 gpd. If the clarifier is 80 ft in diameter by 10 ft deep, what is the clarifier detention time in hours?
- 5.89 A circular clarifier has a diameter of 60 ft. If the primary clarifier influent flow is 2,320,000 gpd, what is the surface overflow rate in gallons per day per square foot?
- 5.90 A rectangular clarifier has a total of 215 ft of weir. What is the weir overflow rate in gallons per day per foot when the flow is 3,728,000 gpd?
- 5.91 A secondary clarifier, 60 ft in diameter, receives a primary effluent flow of 1,910,000 gpd and a return sludge flow of 550,000 gpd. If the MLSS concentration is 2710 mg/L, what is the solids loading rate in pounds per day per square foot on the clarifier?
- 5.92 A circular primary clarifier has a diameter of 70 ft. If the influent flow to the clarifier is 3.10 MGD, what is the surface overflow rate in gallons per day per square foot?
- 5.93 A secondary clarifier, 80 ft in diameter, receives a primary effluent flow of 3,150,000 gpd and a return sludge flow of 810,000 gpd. If the MLSS concentration is 2910 mg/L, what is the solids loading rate in the clarifier in pounds per day per square foot?
- 5.94 The flow to a secondary clarifier is 5.3 MGD. If the influent BOD concentration is 228 mg/L and the effluent BOD concentration is 110 mg/L, how many pounds per day BOD are removed daily?
- 5.95 The flow to a sedimentation tank 90 ft long, 40 ft wide, and 14 ft deep is 5.10 MGD. What is the detention time in the tank in hours?
- 5.96 The average flow to a clarifier is 1940 gpm. If the diameter of the weir is 70 ft, what is the weir overflow rate in gallons per day per foot?
- 5.97 The flow to a secondary clarifier is 4,440,000 gpd. How many pounds of BOD are removed daily if the influent BOD concentration is 190 mg/L and the effluent BOD concentration is 106 mg/L?
- 5.98 The flow to a primary clarifier is 3.88 MGD. If the influent to the clarifier has a suspended solids concentration of 290 mg/L and the primary clarifier effluent has a suspended solids concentration of 80 mg/L, how many pounds per day suspended solids are removed by the clarifier?
- 5.99 The primary clarifier influent has a BOD concentration of 260 mg/L. If the primary clarifier effluent has a BOD concentration of 69 mg/L, what is the BOD removal efficiency of the primary clarifier?
- 5.100 A sedimentation tank is 90 ft long by 40 ft wide. If the flow to the tank is 2,220,000 gpd, what is the surface overflow rate in gallons per day per square foot?

5.4 TRICKLING FILTERS

5.4.1 Hydraulic Loading Rate

- 5.101 A trickling filter, 80 ft in diameter, treats a primary effluent flow of 660,000 gpd. If the recirculated flow to the trickling filter is 120,000 gpd, what is the hydraulic loading rate on the trickling filter in gallons per day per square foot?
- 5.102 A high-rate trickling filter receives a flow of 2360 gpm. If the filter has a diameter of 90 ft, what is the hydraulic loading rate on the filter in gallons per day per square foot?
- 5.103 The total influent flow (including recirculation) to a trickling filter is 1.5 MGD. If the trickling filter is 90 ft in diameter, what is the hydraulic loading rate on the trickling filter in gallons per day per square foot?
- 5.104 A high-rate trickling filter receives a daily flow of 2.1 MGD. What is the hydraulic loading rate in million gallons per day per acre if the filter is 96 ft in diameter?

5.4.2 Organic Loading Rate

- 5.105 A trickling filter, 100 ft in diameter with a media depth of 6 ft, receives a flow of 1,400,000 gpd. If the BOD concentration of the primary effluent is 210 mg/L, what is the organic loading on the trickling filter in pounds per day BOD per 1000 ft³?
- 5.106 A 90-ft diameter trickling filter with a media depth of 7 ft receives a primary effluent flow of 3,400,000 gpd with a BOD of 111 mg/L. What is the organic loading on the trickling filter in pounds per day BOD per 1000 ft³?
- 5.107 A trickling filter, 80 ft in diameter with a media depth of 7 ft, receives a flow of 0.9 MGD. If the BOD concentration of the primary effluent is 201 mg/L, what is the organic loading on the trickling filter in pounds per day BOD per 1000 ft³?
- 5.108 A trickling filter has a diameter of 90 ft and a media depth of 5 ft. The primary effluent has a BOD concentration of 120 mg/L. If the total flow to the filter is 1.4 MGD, what is the organic loading in pounds per acre-foot?

5.4.3 BOD and SS Removed (lb/days)

- 5.109 If 122 mg/L suspended solids are removed by a trickling filter, how many pounds per day suspended solids are removed when the flow is 3,240,000 gpd?
- 5.110 The flow to a trickling filter is 1.82 MGD. If the primary effluent has a BOD concentration of 250 mg/L and the trickling filter effluent has a BOD concentration of 74 mg/L, how many pounds of BOD are removed?

- 5.111 If 182 mg/L of BOD are removed from a trickling filter when the flow to the trickling filter is 2,920,000 gpd, how many pounds per day BOD are removed?
- 5.112 The flow to a trickling filter is 5.4 MGD. If the trickling filter effluent has a BOD concentration of 28 mg/L and the primary effluent has a BOD concentration of 222 mg/L, how many pounds of BOD are removed daily?

5.4.4 Unit Process or Overall Efficiency

- 5.113 The suspended solids concentration entering a trickling filter is 149 mg/L. If the suspended solids concentration in the trickling filter effluent is 48 mg/L, what is the suspended solids removal efficiency of the trickling filter?
- 5.114 The influent to a primary clarifier has a BOD content of 261 mg/L. The trickling filter effluent BOD is 22 mg/L. What is the BOD removal efficiency of the treatment plant?
- 5.115 The concentration of suspended solids entering a trickling filter is 201 mg/L. If the suspended solids concentration in the trickling filter effluent is 22 mg/L, what is the suspended solids removal efficiency of the trickling filter?
- 5.116 The suspended solids concentration entering a trickling filter is 111 mg/L. If 88 mg/L suspended solids are removed from the trickling filter, what is the suspended solids removal efficiency of the trickling filter?

5.4.5 Recirculation Ratio

- 5.117 A treatment plant receives a flow of 3.4 MGD. If the trickling filter effluent is recirculated at the rate of 3.5 MGD, what is the recirculation ratio?
- 5.118 The influent to the trickling filter is 1.64 MGD. If the recirculated flow is 2.32 MGD, what is the recirculation ratio?
- 5.119 The trickling filter effluent is recirculated at the rate of 3.86 MGD. If the treatment plant receives a flow of 2.71 MGD, what is the recirculation ratio?
- 5.120 A trickling filter has a desired recirculation ratio of 1.6. If the primary effluent flow is 4.6 MGD, what is the desired recirculated flow in million gallons per day?

5.4.6 General Trickling Filter Calculations

- 5.121 A trickling filter 90-ft in diameter treats a primary effluent flow rate of 0.310 MGD. If the recirculated flow to the clarifier is 0.355 MGD, what is the hydraulic loading rate on the trickling filter in gallons per day per square foot?

- 5.122 A treatment plant receives a flow rate of 2.8 MGD. If the trickling filter effluent is recirculated at a rate of 4.55 MGD, what is the recirculation ratio?
- 5.123 A trickling filter 80 ft in diameter with a media depth of 6 ft receives a primary effluent flow rate of 1,350,000 gpd. If the population equivalent BOD is 75 mg/L, what is the organic loading rate on the unit in pounds per day per 1000 ft³?
- 5.124 The flow rate to a trickling filter is 4.1 MGD. If the population equivalent BOD is 81 mg/L and the secondary effluent BOD is 13 mg/L, how many pounds of BOD are removed daily?
- 5.125 A standard-rate filter, 80 ft in diameter, treats a primary effluent flow of 520,000 gpd. If the recirculated flow to the trickling filter is 110,000 gpd, what is the hydraulic loading rate on the filter in gallons per day per square foot?
- 5.126 A trickling filter, 90 ft in diameter with a media depth of 6 ft, receives a flow of 1,400,000 gpd. If the BOD concentration of the primary effluent is 180 mg/L, what is the organic loading on the trickling filter in pounds per day BOD per 1000 ft³?
- 5.127 If 114 mg/L suspended solids are removed by a trickling filter, how many pounds per day suspended solids are removed when the flow is 2,840,000 gpd?
- 5.128 The suspended solids concentration entering a trickling filter is 200 mg/L. If the suspended solids concentration in the trickling filter effluent is 69 mg/L, what is the suspended solids removal efficiency of the trickling filter?
- 5.129 The flow to a trickling filter is 1.44 MGD. If the primary effluent has a BOD concentration of 242 mg/L and the trickling filter effluent has a BOD concentration of 86 mg/L, how many pounds per day of BOD are removed?
- 5.130 A high-rate trickling filter receives a combined primary effluent and recirculated flow of 2.88 MGD. If the filter has a diameter of 90 ft, what is the hydraulic loading rate on the filter in gallons per day per square foot?
- 5.131 The influent of a primary clarifier has a BOD content of 210 mg/L. The trickling filter effluent BOD is 22 mg/L. What is the BOD removal efficiency of the treatment plant?
- 5.132 An 80-ft-diameter trickling filter with a media depth of 6 ft receives a flow of 2,230,000 gpd. If the BOD concentration of the primary effluent is 141 mg/L, what is the organic loading on the trickling filter in pounds per day BOD per 1000 ft³?
- 5.133 A trickling filter has a diameter of 90 ft and an average media depth of 6 ft. The primary effluent has a BOD concentration of 144 mg/L. If the total flow to the filter is 1.26 MGD, what is the organic loading in pounds per day per acre-foot?

- 5.134 The flow to a trickling filter is 4.22 MGD. If the trickling filter effluent has a BOD concentration of 21 mg/L and the primary effluent has a BOD concentration of 199 mg/L, how many pounds of BOD are removed daily?
- 5.135 A treatment plant receives a flow of 3.6 MGD. If the trickling filter effluent is recirculated at the rate of 3.8 MGD, what is the recirculation ratio?
- 5.136 A high-rate trickling filter receives a daily flow of 1.9 MGD. What is the hydraulic loading rate in million gallons per day per acre if the filter is 80 ft in diameter?
- 5.137 The total influent flow (including recirculation) to a trickling filter is 1.93 MGD. If the trickling filter is 90 ft in diameter, what is the hydraulic loading rate on the trickling filter in gallons per day per square foot?
- 5.138 A trickling filter, 70 ft in diameter with a media depth of 6 ft, receives a flow of 0.81 MGD. If the BOD concentration of the primary effluent is 166 mg/L, what is the organic loading on the trickling filter in pounds per day BOD per 1000 ft³?
- 5.139 The influent to the trickling filter is 1.67 MGD. If the recirculated flow is 2.35 MGD, what is the recirculation ratio?
- 5.140 The suspended solids concentration entering a trickling filter is 243 mg/L. If the suspended solids concentration of the trickling filter effluent is 35 mg/L, what is the suspended solids removal efficiency of the trickling filter?

5.5 ROTATING BIOLOGICAL CONTACTORS

5.5.1 Hydraulic Loading Rate

- 5.141 A rotating biological contactor treats a primary effluent flow of 2.98 MGD. If the media surface area is 720,000 ft², what is the hydraulic loading rate on the RBC in gallons per day per square foot?
- 5.142 A rotating biological contactor treats a flow of 4,725,000 gpd. The manufacturer's data sheet indicates a media surface area of 880,000 ft². What is the hydraulic loading rate on the RBC in gallons per day per square foot?
- 5.143 The media surface area is 440,000 ft². A rotating biological contactor treats a flow of 1.55 MGD. What is the hydraulic loading rate on the RBC in gallons per day per square foot?
- 5.144 A rotating biological contactor has a media area of 800,000 ft². For a maximum hydraulic loading of 7 gpd/ft², what is the desired flow to the contactor in gallons per day?

5.5.2 Soluble BOD

- 5.145 The suspended solids concentration of a wastewater is 241 mg/L. If the normal K value at the plant is 0.55, what is the estimated particulate BOD concentration of the wastewater?
- 5.146 The wastewater entering a rotating biological contactor has a BOD content of 222 mg/L. The suspended solids content is 241 mg/L. If the K value is 0.5, what is the estimated soluble BOD (mg/L) of the wastewater?
- 5.147 The wastewater entering a rotating biological contactor has a BOD content of 240 mg/L. The suspended solids concentration of the wastewater is 150 mg/L. If the K value is 0.5, what is the estimated soluble BOD (mg/L) of the wastewater?
- 5.148 A rotating biological contactor receives a 1.9-MGD flow with a BOD concentration of 288 mg/L and SS concentration of 268 mg/L. If the K value is 0.6, how many pounds per day soluble BOD enter the RBC?

5.5.3 Organic Loading Rate

- 5.149 A rotating biological contactor has a media surface area of 980,000 ft² and receives a flow of 4,350,000 gpd. If the soluble BOD concentration of the primary effluent is 160 mg/L, what is the organic loading rate on the RBC in pounds per day per 1000 ft²?
- 5.150 A rotating biological contactor has a media surface area of 640,000 ft² and receives a flow of 1,520,000 gpd. If the soluble BOD concentration of the primary effluent is 179 mg/L, what is the organic loading rate on the RBC in pounds per day per 1000 ft²?
- 5.151 The wastewater flow to an RBC is 2,820,000 gpd. The wastewater has a soluble BOD concentration of 128 mg/L. The RBC media has a total surface area of 660,000 ft². What is the organic loading rate on the RBC in pounds per day per 1000 ft²?
- 5.152 A rotating biological contactor receives a flow of 2.8 MGD. The BOD of the influent wastewater to the RBC is 187 mg/L and the surface area of the media is 765,000 ft². If the suspended solids concentration of the wastewater is 144 mg/L and the K value is 0.52, what is the organic loading rate in pounds per day per 1000 ft²?

5.5.4 General RBC Calculations

- 5.153 A RBC unit treats a flow rate of 0.45 MGD. The two shafts used provide a total surface area of 190,000 ft². What is the hydraulic loading on the unit in gallons per day per square foot?
- 5.154 The influent to a rotating biological contactor has a total BOD concentration of 190 mg/L and a suspended solids concentration of 210 mg/L. If there are 0.6 lb of particulate BOD per pound of suspended solids, estimate the soluble BOD concentration in milligrams per liter.

- 5.155 A rotating biological contactor receives a flow rate of 1.9 MGD. If the influent soluble BOD concentration is 128 mg/L and the total media surface area is 410,000 ft² for the RBC unit, what is the organic loading in pounds per day per 1000 ft²?
- 5.156 Estimate the soluble BOD loading on a rotating biological contactor treating a flow rate of 0.71 MGD. The total unit surface area is 110,000 ft². The total BOD concentration is 210 mg/L with a suspended solids concentration of 240 mg/L and a *K* value of 0.65.
- 5.157 A RBC unit contains two shafts operated in series, each with a surface area of 103,000 ft². The shafts can both be partitioned by baffles at 25% shaft length intervals. Currently, the first stage of the RBC unit is baffled to use 75% of one of the two shafts. The unit receives a flow rate of 0.455 MGD. The primary effluent total BOD concentration is 241 mg/L. The suspended solids concentration is 149 mg/L and the value of *K* is 0.5. Calculate the hydraulic loading, unit organic loading, and first-stage organic loading.
- 5.158 A rotating biological contactor treats a primary effluent flow of 2.96 MGD. If the media surface area is 660,000 ft², what is the hydraulic loading rate on the RBC in gallons per day per square foot?
- 5.159 The suspended solids concentration of a wastewater is 222 mg/L. If the normal *K* value at the plant is 0.5, what is the estimated particulate BOD concentration of the wastewater?
- 5.160 A rotating biological contactor has a media surface area of 720,000 ft² and receives a flow of 1,920,000 gpd. If the soluble BOD concentration of the primary effluent is 151 mg/L, what is the organic loading on the RBC in pounds per day per 1000 ft²?
- 5.161 A rotating biological contactor receives a 2.9-MGD flow with a BOD concentration of 205 mg/L and suspended solids concentration of 210 mg/L. If the *K* value is 0.6, how many pounds per day soluble BOD enter the RBC?
- 5.162 A rotating biological contactor treats a flow of 4,475,000 gpd. The media surface area is 910,000 ft². What is the hydraulic loading rate on the RBC in gallons per day per square foot?
- 5.163 The wastewater flow to a RBC is 2,415,000 gpd. The wastewater has a soluble BOD concentration of 121 mg/L. The RBC media has total surface area of 760,000 ft². What is the organic loading rate on the RBC in pounds per day per 1000 ft²?

5.6 ACTIVATED SLUDGE

5.6.1 Aeration Tank, Secondary Clarifier and Oxidation Ditch Volume

- 5.164 An aeration tank is 80 ft long by 30 ft wide and operates at an average depth of 14 ft. What is the capacity of the tank in gallons?
- 5.165 What is the gallon capacity of an aeration tank that is 80 ft long by 30 ft wide and operates at an average depth of 12 ft?

- 5.166 A secondary clarifier has a diameter of 80 ft and an average depth of 12 ft. What is the volume of water in the clarifier in gallons?
- 5.167 A clarifier has a diameter of 70 ft and an average depth of 10 ft. What is the volume of water in the clarifier in gallons?

5.6.2 BOD or COD Loading (lb/day)

- 5.168 The flow to an aeration tank is 880,000 gpd. If the BOD content of the wastewater entering the aeration tank is 240 mg/L, what is the pounds per day BOD loading?
- 5.169 The flow to an aeration tank is 2980 gpm. If the COD concentration of the wastewater is 160 mg/L, how many pounds of COD are applied to the aeration tank daily?
- 5.170 The BOD content of the wastewater entering an aeration tank is 165 mg/L. If the flow to the aeration tank is 3,240,000 gpd, what is the pounds per day BOD loading?
- 5.171 The daily flow to an aeration tank is 4,880,000 gpd. If the COD concentration of the influent wastewater is 150 mg/L, how many pounds of COD are applied to the aeration tank daily?

5.6.3 Aeration Tank: Solids Inventory

- 5.172 If the mixed liquor suspended solids concentration is 2110 mg/L and the aeration tank has a volume of 460,000 gal, how many pounds of suspended solids are in the aeration tank?
- 5.173 The aeration tank of a conventional activated sludge plant has a mixed liquor volatile suspended solids concentration of 2420 mg/L. If the aeration tank is 90 ft long by 50 ft wide and has wastewater to a depth of 16 ft, how many pounds of MLVSS are under aeration?
- 5.174 The aeration tank of a conventional activated sludge plant has a mixed liquor volatile suspended solids concentration of 2410 mg/L. If the aeration tank is 80 ft long by 40 ft wide and has wastewater to a depth of 16 ft, how many pounds of MLVSS are under aeration?
- 5.175 The aeration tank is 110 ft long by 30 ft wide and has wastewater to a depth of 16 ft. If the aeration tank of this conventional activated sludge plant has a mixed liquor suspended solids concentration of 2740 mg/L, how many pounds of MLSS are under aeration?
- 5.176 An aeration basin is 110 ft long by 50 ft wide and has wastewater to a depth of 16 ft. If the mixed liquor suspended solids concentration in the aeration tank is 2470 mg/L, with a volatile solids content of 73%, how many pounds of MLVSS are under aeration?

5.6.4 Food-to-Microorganism (F/M) Ratio

- 5.177 An activated sludge aeration tank receives a primary effluent flow of 2.72 MGD with a BOD concentration of 198 mg/L. The mixed liquor volatile suspended solids concentration is 2610 mg/L; the aeration tank volume is 480,000 gal. What is the current F/M ratio?

- 5.178 An activated sludge aeration tank receives a primary effluent flow of 3,350,000 gpd with a BOD of 148 mg/L. The mixed liquor volatile suspended solids is 2510 mg/L and the aeration tank volume is 490,000 gal. What is the current F/M ratio?
- 5.179 The flow to a 195,000-gallon oxidation ditch is 320,000 gpd. The BOD concentration of the wastewater is 180 mg/L. If the mixed liquor suspended solids concentration is 2540 mg/L with a volatile solids content of 72%, what is the F/M ratio?
- 5.180 The desired F/M ratio at an extended aeration activated sludge plant is 0.7 lb BOD per lb MLVSS. If the 3.3-MGD primary effluent flow has a BOD of 181 mg/L, how many pounds of MLVSS should be maintained in the aeration tank?
- 5.181 The desired F/M ratio at a particular activated sludge plant is 0.4 lb BOD per lb MLVSS. If the 2,510,000-gpd primary effluent flow has a BOD concentration of 141 mg/L, how many pounds of MLVSS should be maintained in the aeration tank?

5.6.5 Sludge Age

- 5.182 An aeration tank has a total of 16,100 lb of mixed liquor suspended solids. If a total of 2630 lb/day suspended solids enter the aeration tank in the primary effluent flow, what is the sludge age in the aeration tank?
- 5.183 An aeration tank contains 480,000 gal of wastewater with a MLSS concentration of 2720 mg/L. If the primary effluent flow is 2.9 MGD with a suspended solids concentration of 110 mg/L, what is the sludge age?
- 5.184 An aeration tank is 110 ft long by 50 ft wide and operates at a depth of 14 ft. The MLSS concentration in the aeration tank is 2510 mg/L. If the influent flow to the tank is 2.88 MGD with a suspended solids concentration of 111 mg/L, what is the sludge age?
- 5.185 The MLSS concentration in the aeration tank is 2960 mg/L. The aeration tank is 110 ft long by 50 ft wide and operates at a depth of 14 ft. If the influent flow to the tank is 1.98 MGD and has a suspended solids concentration of 110 mg/L, what is the sludge age?
- 5.186 An oxidation ditch has a volume of 211,000 gal. The 270,000-gpd flow to the oxidation ditch has a suspended solids concentration of 205 mg/L. If the MLSS concentration is 3810 mg/L, what is the sludge age in the oxidation ditch?

5.6.6 Solids Retention Time

- 5.187 An activated sludge system has a total of 29,100 lb of mixed liquor suspended solids. The suspended solids leaving the final clarifier in the effluent is calculated to be 400 lb/day. The pounds suspended solids wasted from the final clarifier is 2920 lb/day. What is the solids retention time in days?

5.188 Determine the solids retention time given the following data:

Aeration tank volume = 1,500,000 gal

Final clarifier = 106,000 gal

Population flow = 3.3 MGD

WAS = 5870 mg/L

WAS pumping rate = 72,000 gpd

MLSS = 2710 mg/L

Secondary effluent SS = 25 mg/L

Average clarifier core SS = 1940 mg/L

5.189 An aeration tank has a volume of 460,000 gal. The final clarifier has a volume of 152,000 gal. The MLSS concentration in the aeration tank is 2222 mg/L. If a total of 1610 pounds per day suspended solids are wasted and 240 pounds per day suspended solids are in the secondary effluent, what is the solids retention time for the activated sludge system?

5.190 Calculate the solids retention time given the following data:

Aeration tank volume = 350,000 gal

Final clarifier = 125,000 gal

Population equivalent flow = 1.4 MGD

WAS = 6210 mg/L

WAS pumping rate = 27,000 gpd

MLSS = 2910 mg/L

Secondary effluent SS = 16 mg/L

5.6.7 Return Sludge Rate

5.191 The settleability test after 30 minutes indicates a sludge settling volume of 220 mL/L. Calculate the RAS flow as a ratio to the secondary influent flow.

5.192 Given the following data, calculate the RAS return rate:

MLSS = 2480 mg/L

RAS SS = 7840 mg/L

WAS SS = 7840 mg/L

WAS pumping rate = 61,000 gpd

Population equivalent = 3.6 MGD

5.193 A total of 280 mL/L sludge settled during a settle ability test after 30 minutes. The secondary influent flow is 3.25 MGD. Calculate the RAS flow.

- 5.194 Given the following data, calculate the RAS return rate using the aeration tank solids balance equation:

MLSS = 2200 mg/L

RAS SS = 7520 mg/L

Population equivalent = 6.4 MGD

5.6.8 Wasting Rate

- 5.195 The desired F/M ratio for an activated sludge system is 0.5 lb BOD/lb MLVSS. It has been calculated that 3400 lb of BOD enter the aeration tank daily. If the volatile solids content of the MLSS is 69%, how many pounds MLSS are desired in the aeration tank?

- 5.196 Using a desired sludge age, it was calculated that 14,900 lb MLSS are desired in the aeration tank. If the aeration tank volume is 790,000 gal and the MLSS concentration is 2710 mg/L, how many pounds per day MLSS should be wasted?

- 5.197 Given the following data, determine the pounds per day suspended solids to be wasted:

Aeration tank volume = 1,200,000 gal

Influent flow = 3,100,000 gpd

BOD = 110 mg/L

MLSS = 2200 mg/L

%VS = 68%

Desired F/M ratio = 0.4 lb BOD/lb MLVSS

- 5.198 The desired sludge age for an activated sludge plant is 5.6 days. The aeration tank volume is 910,000 gal. If 3220 lb/day suspended solids enter the aeration tank and the MLSS concentration is 2900 mg/L, how many pounds per day MLSS (suspended solids) should be wasted?

- 5.199 The desired sludge retention time for an activated sludge plant is 9 days. The system has a total of 32,400 lb suspended solids. The secondary effluent flow is 3,220,000 gpd with a suspended solids content of 23 mg/L. How many pounds per day WAS suspended solids must be wasted to maintain the desired SRT?

5.6.9 Waste Activated Sludge Pumping Rate

- 5.200 It has been determined that 5580 lb/day solids must be removed from the secondary system. If the RAS suspended solids concentration is 6640 mg/L, what must the WAS pumping rate be in million gallons per day?

- 5.201 The WAS suspended solids concentration is 6200 mg/L. If 8710 lb/day dry solids are to be wasted, what must the WAS pumping rate be in million gallons per day?

5.202 Given the following data, calculate the WAS pumping rate required in million gallons per day:

Clarifier + aerator volume = 1.8 MG

Influent flow = 4.3 MGD

Desired SRT = 9 days

RAS SS = 7420 mg/L

MLSS = 2725 mg/L

Secondary effluent SS = 18 mg/L

5.203 Given the following data, calculate the WAS pumping rate required in million gallons per day:

Clarifier + aerator volume = 1.7 MG

Influent flow = 3.8 MGD

Desired SRT = 8.5 days

RAS SS = 6140 mg/L

MLSS = 2610 mg/L

Secondary effluent SS = 14 mg/L

5.6.10 Oxidation Ditch Detention Time

5.204 An oxidation ditch has a volume of 166,000 gal. If the flow to the oxidation ditch is 190,000 gpd, what is the detention time in hours?

5.205 An oxidation ditch receives a flow of 0.23 MGD. If the volume of the oxidation ditch is 370,000 gal, what is the detention time in hours?

5.206 If the volume of the oxidation ditch is 420,000 gal and the oxidation ditch receives a flow of 305,000 gpd, what is the detention time in hours?

5.207 The volume of an oxidation ditch is 210,000 gal. If the oxidation ditch receives a flow of 310,000 gpd, what is the detention time in hours?

5.6.11 General Activated Sludge Calculations

5.208 An aeration tank is 80 ft long by 40 ft wide and operates at an average depth of 15 ft. What is the capacity of the tank in gallons?

5.209 The BOD content of the wastewater entering an aeration tank is 220 mg/L. If the flow to the aeration tank is 1,720,000 gpd, what is the pounds per day BOD loading?

5.210 The flow to a 220,000-gal oxidation ditch is 399,000 gpd. The BOD concentration of the wastewater is 222 mg/L. If the mixed liquor suspended solids concentration is 3340 mg/L, with a volatile solids content of 68%, what is the F/M ratio?

- 5.211 A clarifier has a diameter of 90 ft and an average depth of 12 ft. What is the capacity of the clarifier in gallons?
- 5.212 The daily flow to an aeration tank is 3,920,000 gpd. If the COD concentration of the influent wastewater is 160 mg/L, how many pounds of COD are applied to the aeration tank daily?
- 5.213 An aeration tank contains 530,000 gal of wastewater with a MLSS concentration of 2700 mg/L. If the primary effluent flow is 1.8 MGD with a suspended solids concentration of 190 mg/L, what is the sludge age?
- 5.214 A mixed liquor sample is poured into a 2100-mL settlometer. After 30 minutes, there is a settled sludge volume of 440 mL. If the plant flow rate (Q) is 6.1 MGD, what should the return sludge flow rate be in gallons per minute?
- 5.215 The mixed liquor in a 0.45-MG aeration tank has a mixed liquor suspended solids concentration of 2100 mg/L. The waste sludge is being removed at a rate of 0.120 MGD and has a concentration of 4920 mg/L. If the target MLSS is 2050 mg/L, what should the new waste sludge pumping rate be?
- 5.216 The mixed liquor in a 0.44-MG aeration tank has a mixed liquor suspended solids concentration of 2090 mg/L. The waste sludge is being removed at a rate of 87.3 gpm and has a concentration of 4870 mg/L. If the target MLSS is 2170 mg/L, what should the new waste sludge pumping rate be in gallons per minute?
- 5.217 An aeration tank has a mixed liquor suspended solids concentration of 2210 mg/L. The volume of the tank is 0.66 MG. The plant flow rate is 3.25 MGD. The primary effluent suspended solids concentration is 131 mg/L. What is the sludge age?
- 5.218 The desired F/M ratio at a particular activated sludge plant is 0.6 lb BOD/lb MLVSS. If the 2.88-MGD primary effluent flow has a BOD concentration of 146 mg/L, how many pounds of MLVSS should be maintained in the aeration tank?
- 5.219 An oxidation ditch receives a flow of 0.31 MGD. If the volume of the oxidation ditch is 310,000 gal, what is the detention time in hours?
- 5.220 The desired F/M ratio at a particular activated sludge plant is 0.8 lb COD/lb MLVSS. If the 2,410,000-gpd primary effluent flow has a COD concentration of 161 mg/L, how many pounds MLVSS should be maintained in the aeration tank?
- 5.221 An aeration tank is 110 ft long by 40 ft wide and operates at a depth of 14 ft. The mixed liquor suspended solids concentration in the aeration tank is 2910 mg/L. If the influent flow to the tank is 1.4 MGD and has a suspended solids concentration of 170 mg/L, what is the sludge age?
- 5.222 If the volume of an oxidation ditch is 620,000 gal, and the oxidation ditch receives a flow of 0.36 MGD, what is the detention time in hours?

- 5.223 An oxidation ditch has a volume of 260,000 gal. The 0.4-MGD flow to the oxidation ditch has a suspended solids concentration of 200 mg/L. If the MLSS concentration is 3980 mg/L, what is the sludge age in the oxidation ditch?
- 5.224 If the mixed liquor suspended solids concentration is 2710 mg/L and the aeration tank has a volume of 440,000 gal, how many pounds of suspended solids are in the aeration tank?
- 5.225 The desired F/M ratio at a conventional activated sludge plant is 0.4 lb BOD/lb MLVSS. If the 2.88-MGD primary effluent flow has a BOD of 146 mg/L, how many pounds of MLVSS should be maintained in the aeration tank?
- 5.226 The aeration tank of a conventional activated sludge plant has a mixed liquor volatile suspended solids concentration of 2510 mg/L. The tank is 110 ft long by 40 ft wide and has wastewater to a depth of 18 ft. How many pounds of MLVSS are in the tank?
- 5.227 The MLSS concentration in an aeration tank is 2740 mg/L. The aeration tank contains 710,000 gal of wastewater. If the primary effluent flow is 1.86 MGD with a suspended solids concentration of 184 mg/L, what is the sludge age?
- 5.228 Determine the solids retention time given the following data:
- Aeration tank volume = 1,410,000 gal
 - Final clarifier = 118,000 gal
 - Population equivalent flow = 3.1 MGD
 - Secondary effluent SS = 20 mg/L
 - Clarifier core SS = 1910 mg/L
 - MLSS = 2680 mg/L
 - WAS = 5870 mg/L
 - WAS flow rate = 76,000 gpd
- 5.229 The settleability test after 30 minutes indicates a sludge settling volume of 231 mL/L. Calculate the RAS flow as a ratio to the secondary influent flow.
- 5.230 The desired F/M ratio at an activated sludge plant is 0.5 lb BOD/lb MLVSS. It was calculated that 3720 lb/day BOD enter the aeration tank. If the volatile solids content of the MLSS is 70%, how many pounds MLSS are desired in the aeration tank?
- 5.231 The desired sludge age for a plant is 5 days. The aeration tank volume is 780,000 gal. If 3740 lb/day suspended solids enter the aeration tank and the MLSS concentration is 2810 mg/L, how many pounds per day MLSS should be wasted?
- 5.232 It has been determined that 4110 lb/day dry solids must be removed from the secondary system. If the RAS suspended solids concentration is 6410 mg/L, what must the WAS pumping rate be in million gallons per day?

5.7 WASTE TREATMENT PONDS

5.7.1 BOD Loading

- 5.233 Calculate the BOD loading (pounds per day) on a pond if the influent flow is 410,000 gpd with a BOD of 250 mg/L.
- 5.234 The BOD concentration of the wastewater entering a pond is 161 mg/L. If the flow to the pond is 225,000 gpd, how many pounds per day BOD enter the pond?
- 5.235 The flow to a waste treatment pond is 180 gpm. If the BOD concentration of the water is 223 mg/L, how many pounds of BOD are applied to the pond daily?
- 5.236 The BOD concentration of the influent wastewater to a waste treatment pond is 200 mg/L. If the flow to the pond is 130 gpm, how many pounds of BOD are applied to the pond daily?

5.7.2 Organic Loading Rate

- 5.237 A 7.8-acre pond receives a flow of 219,000 gpd. If the influent flow has a BOD content of 192 mg/L, what is the organic loading rate on the pond in pounds per day per acre?
- 5.238 A pond has an average width of 420 ft and an average length of 740 ft. The flow to the pond is 167,000 gpd with a BOD content of 145 mg/L. What is the organic loading rate on the pond in pounds per day per acre?
- 5.239 The flow to a pond is 72,000 gpd with a BOD content of 128 mg/L. The pond has an average width of 240 ft and an average length of 391 ft. What is the organic loading rate on the pond in pounds per day per acre?
- 5.240 The maximum desired organic loading rate for a 15-ac pond is 22 lb BOD/day/ac. If the influent flow to the pond has a BOD concentration of 189 mg/L, what is the maximum desirable flow to the pond in million gallons per day?

5.7.3 BOD Removal Efficiency

- 5.241 The BOD entering a waste treatment pond is 210 mg/L. If the BOD in the pond effluent is 41 mg/L, what is the BOD removal efficiency of the pond?
- 5.242 The influent of a waste treatment pond has a BOD content 267 mg/L. If the BOD content of the pond effluent is 140 mg/L, what is the BOD removal efficiency of the pond?
- 5.243 The BOD entering a waste treatment pond is 290 mg/L. If the BOD in the pond effluent is 44 mg/L, what is the BOD removal efficiency of the pond?
- 5.244 The BOD entering a waste treatment pond is 142 mg/L. If the BOD in the pond effluent is 58 mg/L, what is the BOD removal efficiency of the pond?

5.7.4 Hydraulic Loading Rate

- 5.245 A 22-ac pond receives a flow of 3.6 ac-ft/day. What is the hydraulic loading rate on the pond in inches per day?
- 5.246 A 16-ac pond receives a flow of 6 ac-ft/day. What is the hydraulic loading rate on the pond in inches per day?
- 5.247 A waste treatment pond receives a flow of 2,410,000 gpd. If the surface area of the pond is 17 ac, what is the hydraulic loading in inches per day?
- 5.248 A waste treatment pond receives a flow of 1,880,000 gpd. If the surface area of the pond is 16 ac, what is the hydraulic loading in inches per day?

5.7.5 Population Loading and Population Equivalent

- 5.249 A 5-ac wastewater pond serves a population of 1340 people. What is the population loading on the pond in people per acre?
- 5.250 A wastewater pond serves a population of 5580 people. If the pond covers 19 ac, what is the population loading on the pond in people per acre?
- 5.251 A 0.8-MGD wastewater flow has a BOD concentration of 1640 mg/L. Using an average of 0.3 lb BOD/day/person, what is the population equivalent of this wastewater flow?
- 5.252 A 257,000-gpd wastewater flow has a BOD content of 2260 mg/L. Using an average of 0.2 lb BOD/day/person, what is the population equivalent of this flow?

5.7.6 Detention Time

- 5.253 A waste treatment pond has a total volume of 19 ac-ft. If the flow to the pond is 0.44 ac-ft/day, what is the detention time of the pond in days?
- 5.254 A waste treatment pond is operated at a depth of 8 ft. The average width of the pond is 450 ft and the average length is 700 ft. If the flow to the pond is 0.3 MGD, what is the detention time in days?
- 5.255 The average width of the pond is 250 ft and the average length is 400 ft. A waste treatment pond is operated at a depth of 6 ft. If the flow to the pond is 72,000 gpd, what is the detention time in days?
- 5.256 A waste treatment pond has an average length of 700 ft, an average width of 410 ft, and a water depth of 5 ft. If the flow to the pond is 0.48 ac-ft/day, what is the detention time for the pond?

5.7.7 General Waste Treatment Pond Calculations

- 5.257 A wastewater treatment pond has an average length of 720 ft with an average width of 460 ft. If the flow rate to the pond is 310,000 gpd, and it is operated at a depth of 6 ft, what is the hydraulic detention time in days?

- 5.258 What is the detention time for a pond receiving an influent flow rate of 0.50 ac-ft each day? The pond has an average length of 705 ft and an average width of 430 ft. The operating depth of the pond is 50 in.
- 5.259 A waste treatment pond has an average width of 395 ft and an average length of 698 ft. The influent flow rate to the pond is 0.16 MGD with a BOD concentration of 171 mg/L. What is the organic loading rate on the pond in pounds per day per acre?
- 5.260 A pond 750 ft long by 435 ft wide receives an influent flow rate of 0.79 ac-ft/day. What is the hydraulic loading rate on the pond in inches per day?
- 5.261 The BOD concentration of the wastewater entering a pond is 192 mg/L. If the flow to the pond is 370,000 gpd, how many pounds per day BOD enter the pond?
- 5.262 A 9.1-ac pond receives a flow of 285,000 gpd. If the influent flow has a BOD content of 240 mg/L, what is the organic loading rate on the pond in pounds per day per acre?
- 5.263 The BOD entering a waste treatment pond is 220 mg/L. If the BOD concentration in the pond effluent is 44 mg/L, what is the BOD removal efficiency of the pond?
- 5.264 A 22-ac pond receives a flow of 3.8 ac-ft/day. What is the hydraulic loading on the pond in inches per day?
- 5.265 The BOD entering a waste treatment pond is 166 mg/L. If the BOD concentration in the pond effluent is 73 mg/L, what is the BOD removal efficiency of the pond?
- 5.266 The flow to a waste treatment pond is 210 gpm. If the BOD concentration of the water is 222 mg/L, how many pounds of BOD are applied to the pond daily?
- 5.267 The flow to a pond is 80,000 gpd with a BOD content of 135 mg/L. The pond has an average width of 220 ft and an average length of 400 ft. What is the organic loading rate on the pond in pounds per day per acre?
- 5.268 A waste treatment pond receives a flow of 1,980,000 gpd. If the surface area of the pond is 21 ac, what is the hydraulic loading in inches per day?
- 5.269 A wastewater pond serves a population of 6200 people. If the area of the pond is 22 ac, what is the population loading on the pond?
- 5.270 A waste treatment pond has a total volume of 18.4 ac-ft. If the flow to the pond is 0.52 ac-ft/day, what is the detention time of the pond in days?
- 5.271 A 0.9-MGD wastewater flow has a BOD concentration of 2910 mg/L. Using an average of 0.4 lb BOD/day/person, what is the population equivalent of this wastewater flow?
- 5.272 A waste treatment pond is operated at a depth of 6 ft. The average width of the pond is 440 ft and the average length is 730 ft. If the flow to the pond is 0.45 MGD, what is the detention time in days?

5.8 CHEMICAL DOSAGE

5.8.1 Full-Strength Chemical Feed Rate

- 5.273 Determine the chlorinator setting in pounds per day required to treat a flow of 4.6 MGD with a chlorine dose of 3.4 mg/L.
- 5.274 The desired dosage for a dry polymer is 11 mg/L. If the flow to be treated is 1,680,000 gpd, how many pounds per day polymer will be required?
- 5.275 To neutralize a sour digester, 1 lb of lime is to be added for every pound of volatile acids in the digester sludge. If the digester contains 200,000 gal of sludge with a volatile acid level of 2200 mg/L, how many pounds of lime should be added?
- 5.276 A total of 320 lb of chlorine was used during a 24-hr period to chlorinate a flow of 5.12 MGD. At this lb/day dosage rate, what was the mg/L dosage rate?

5.8.2 Chlorine Dose, Demand, and Residual

- 5.277 The secondary effluent is tested and found to have a chlorine demand of 4.9 mg/L. If the desired residual is 0.8 mg/L, what is the desired chlorine dose in milligrams per liter?
- 5.278 The chlorine dosage for a secondary effluent is 8.8 mg/L. If the chlorine residual after 30 minutes of contact time is found to be 0.9 mg/L, what is the chlorine demand expressed in milligrams per liter?
- 5.279 The chlorine demand of a secondary effluent is 7.9 mg/L. If a chlorine residual of 0.6 mg/L is desired, what is the desired chlorine dosage in milligrams per liter?
- 5.280 What should the chlorinator setting be in pounds per day to treat a flow of 4.0 MGD if the chlorine demand is 9 mg/L and a chlorine residual of 1.7 mg/L is desired?
- 5.281 A total chlorine dosage of 11.1 mg/L is required to treat a water unit. If the flow is 2.88 MGD and the hypochlorite has 65% available chlorine, how many pounds per day of hypochlorite will be required?
- 5.282 The desired dose of polymer is 9.8 mg/L. The polymer provides 60% active polymer. If a flow of 4.1 MGD is to be treated, how many pounds per day of the polymer compound will be required?
- 5.283 A wastewater flow of 1,724,000 gpd requires a chlorine dose of 19 mg/L. If hypochlorite (65% available chlorine) is to be used, how many pounds per day of hypochlorite are required?
- 5.284 A total of 950 lb of 65% hypochlorite is used in a day. If the flow rate treated is 5.65 MGD, what is the chlorine dosage in milligrams per liter?

5.8.3 Percent Strength of Solutions

- 5.285 If a total of 12 oz. of dry polymer is added to 16 gal of water, what is the percent strength (by weight) of the polymer?
- 5.286 How many pounds of dry polymer must be added to 24 gal of water to make a 0.9% polymer solution?
- 5.287 If 160 g of dry polymer are dissolved in 12 gal of water, what percent strength is the solution (1 g = 0.0022 lb)?
- 5.288 A 10% liquid polymer is to be used in making up a polymer solution. How many pounds of liquid polymer should be mixed with water to produce 172 lb of a 0.5% polymer solution?
- 5.289 A 10% liquid polymer will be used in making up a solution. How many gallons of liquid polymer should be added to the water to make up 55 gal of a 0.3% polymer solution? The liquid polymer has a specific gravity of 1.25; assume that the polymer solution has a specific gravity of 1.0.
- 5.290 How many gallons of 12% liquid polymer should be mixed with water to produce 111 gal of a 0.6% polymer solution? The density of the polymer liquid is 11.2 lb/gal. Assume that the density of the polymer solution is 8.34 lb/gal.

5.8.4 Mixing Solutions of Different Strength

- 5.291 If 26 lb of a 10% solution are mixed with 110 lb of a 0.5% strength solution, what is the percent strength of the solution mixture?
- 5.292 If 6 gal of a 12% strength solution are added to 30 gal of a 0.4% strength solution, what is the percent strength of the solution mixture? Assume that the 12% solution weighs 10.2 lb/gal and the 0.3% strength solution weighs 8.4 lb/gal.
- 5.293 If 12 gal of a 10% strength solution are mixed with 42 gal of a 0.28% strength solution, what is the percent strength of the solution mixture? Assume that the 10% solution weighs 10.2 lb/gal and the 0.26% solution weighs 8.34 lb/gal.

5.8.5 Solution Chemical Feeder Setting (gpd)

- 5.294 Jar tests indicate that the best liquid alum dose for a water unit is 10 mg/L. The flow to be treated is 4.10 MGD. Determine the setting for the liquid alum chemical feeder in gallons per day if the liquid alum contains 5.88 lb of alum per gallon of solution.
- 5.295 Jar tests indicate that the best liquid alum dose for a water unit is 8 mg/L. The flow to be treated is 1,440,000 gpd. Determine the setting for the liquid alum chemical feeder in gallons per day if the liquid alum contains 6.15 lb of alum per gallon of solution.

- 5.296 Jar tests indicate that the best liquid alum dose for a water unit is 11 mg/L. The flow to be treated is 2.13 MGD. Determine the setting for the liquid alum chemical feeder in gallons per day if the liquid alum is a 60% solution. Assume that the alum solution weighs 8.34 lb/gal.
- 5.297 The flow to the plant is 4,440,000 gpd. Jar testing indicates that the optimum alum dose is 9 mg/L. What should the setting be for the solution feeder in gallons per day if the alum solution is a 60% solution? Assume that the solution weighs 8.34 lb/gal.
- 5.298 The required chemical pumping rate has been calculated to be 30 gpm. If the maximum pumping rate is 80 gpm, what should the percent stroke setting be?
- 5.299 The required chemical pumping rate has been calculated to be 22 gpm. If the maximum pumping rate is 80 gpm, what should the percent stroke setting be?
- 5.300 The required chemical pumping rate has been determined to be 14 gpm. What is the percent stroke setting if the maximum rate is 70 gpm?
- 5.301 The maximum pumping rate is 110 gpm. If the required pumping rate is 40 gpm, what is the percent stroke setting?

5.8.6 Solution Chemical Feeder Setting (mL/min)

- 5.302 The desired solution feed rate was calculated to be 35 gpd. What is this feed rate expressed as milliliters per minute?
- 5.303 The desired solution feed rate was calculated to be 45 gpd. What is this feed rate expressed as milliliters per minute?
- 5.304 The optimum polymer dose has been determined to be 9 mg/L. The flow to be treated is 910,000 gpd. If the solution to be used contains 60% active polymer, what should the solution chemical feeder setting be in milliliters per minute? Assume that the polymer solution weighs 8.34 lb/gal.
- 5.305 The flow to be treated is 1,420,000 gpd. The optimum polymer dose has been determined to be 11 mg/L. If the solution to be used contains 60% active polymer, what should the solution chemical feeder setting be in milliliters per minute. Assume that the polymer solution weighs 8.34 lb/gal.

5.8.7 Dry Chemical Feeder Calibration

- 5.306 Calculate the actual chemical feed rate in pounds per day if a container is placed under a chemical feeder and a total of 2.1 lb is collected during a 30-minute period.
- 5.307 Calculate the actual chemical feed rate in pounds per day if a bucket is placed under a chemical feeder and a total of 1 lb, 8 oz. is collected during a 30-minute period.

- 5.308 To calibrate a chemical feeder, a container is first weighed (12 oz.) and then placed under the chemical feeder. After 30 minutes the container is weighed again. If the weight of the container with chemical is 2.10 lb, what is the actual chemical feed rate in pounds per day?
- 5.309 A chemical feeder is to be calibrated. The container to be used to collect chemical is placed under the chemical feeder and weighed (0.5 lb). After 30 minutes, the weight of the container and chemical is found to be 2.5 lb. Based on this test, what is the actual chemical feed rate in pounds per day?

5.8.8 Solution Chemical Feeder Calibration

- 5.310 A calibration test is conducted for a solution chemical feeder. During 5 minutes, the solution feeder delivers a total of 770 mL. The polymer solution is 1.4% solution. What is the polymer feed rate in pounds per day? Assume that the polymer solution weighs 8.34 lb/gal.
- 5.311 A calibration test is conducted for a solution chemical feeder. During the 5-minute test, the pump delivered 900 mL of the 1.2% polymer solution. What is the polymer dosage rate in pounds per day? Assume that the polymer solution weighs 8.34 lb/gal.
- 5.312 A calibration test is conducted for a solution chemical feeder. During a 5-minute test, the pump delivered 610 mL of 1.3% polymer solution. The specific gravity of the polymer solution is 1.2. What is the polymer dosage rate in pounds per day?
- 5.313 During a 5-minute test, a pump delivered 800 mL of a 0.5% polymer solution. A calibration test is conducted for the solution chemical feeder. The specific gravity of the polymer solution is 1.15. What is the polymer dosage rate in pounds per day?

5.8.9 Solution Chemical Feeder Calibration (Based on Drop in Solution Tank Level)

- 5.314 A pumping rate calibration test is conducted for a 3-minute period. The liquid level in the 4-ft-diameter solution tank is measured before and after the test. If the level drops 1.5 ft during a 3-minute test, what is the pumping rate in gallons per minute?
- 5.315 A pumping rate calibration test is conducted for a 5-minute period. The liquid level in the 5-ft-diameter tank is measured before and after the test. If the level drops 15 in. during the test, what is the pumping rate in gallons per minute?
- 5.316 A pump test indicates that a pump delivers 30 gpm during a 4-minute pumping test. The diameter of the solution tank is 5 ft. What was the expected drop, in feet, in solution level during the pumping test?

5.317 The liquid level in the 5-ft-diameter solution tank is measured before and after the test. A pumping rate calibration test is conducted for a 3-minute period. If the level drops 18 in. during the test, what is the pumping rate in gallons per minute?

5.8.10 Average Use Calculations

5.318 The amount of chemical used for each day of a week is given below. Based on this information, what was the average pounds per day chemical use during the week?

Monday	81 lb/day	Friday	79 lb/day
Tuesday	73 lb/day	Saturday	83 lb/day
Wednesday	74 lb/day	Sunday	81 lb/day
Thursday	66 lb/day		

5.319 The average chemical use at a plant is 115 lb/day. If the chemical inventory in stock is 2300 lb, how many days' supply is this?

5.320 The chemical inventory in stock is 1002 lb. If the average chemical use at a plant is 66 lb/day, how many days' supply is this?

5.321 The average gallons of polymer solution used each day at a treatment plant are 97 gpd. A chemical feed tank has a diameter of 5 ft and contains solution to a depth of 3 ft, 4 in. How many days' supply is represented by the solution in the tank?

5.8.11 General Chemical Dosage Calculations

5.322 The desired dosage for a dry polymer is 11 mg/L. If the flow to be treated is 3,750,000 gpd, how many pounds per day polymer will be required?

5.323 A total chlorine dosage of 7.1 mg/L is required to treat a particular water unit. If the flow is 3.24 MGD and the hypochlorite has 65% available chlorine, how many pounds per day of hypochlorite will be required?

5.324 How many pounds of dry polymer must be added to 32 gal of water to make a 0.2% polymer solution?

5.325 Calculate the actual chemical feed rate in pounds per day if a bucket is placed under a chemical feeder and a total of 1.9 lb is collected during a 30-minute period.

5.326 Jar tests indicate that the best liquid alum dose for a water unit is 12 mg/L. The flow to be treated is 2,750,000 gpd. Determine the setting for the liquid alum chemical feeder in gallons per day if the liquid alum contains 5.88 lb of alum per gallon of solution.

5.327 A total of 379 lb of chlorine was used during a 24-hr period to chlorinate a flow of 5,115,000 gpd. At this pounds per day dosage rate, what was the milligrams per liter dosage rate?

- 5.328 To calibrate a chemical feeder, a container is first weighed (12 oz.) and then placed under the chemical feeder. After 30 minutes the bucket is weighed again. If the weight of the bucket with the chemical is 2 lb, 6 oz., what is the actual chemical feed rate in pounds per day?
- 5.329 The flow to a plant is 3,244,000 gpd. Jar testing indicates that the optimum alum dose is 10 mg/L. What should the settling rate be in gallons per day for the solution feeder if the alum solution is a 60% solution? Assume that the alum solution weighs 8.34 lb/gal.
- 5.330 The desired chemical pumping rate has been calculated at 32 gpm. If the minimum pumping rate is 90 gpm, what should the percent stroke setting be?
- 5.331 The chlorine dosage for a secondary effluent is 7.8 mg/L. If the chlorine residual after 30 minutes of contact time is found to be 0.5 mg/L, what is the chlorine demand expressed in milligrams per liter?
- 5.332 How many gallons of 12% liquid polymer should be mixed with water to produce 60 gal of a 0.4% polymer solution? The density of the polymer liquid is 9.6 lb/gal. Assume that the density of the polymer solution is 8.34 lb/gal.
- 5.333 A calibration test is conducted for a solution chemical feeder. During 5 minutes, the solution feeder delivers a total of 660 mL. The polymer solution is a 1.2% solution. What is the feed rate in pounds per day? Assume that the polymer solution weighs 8.34 lb/gal.
- 5.334 A pump operates at a rate of 30 gpm. How many feet will the liquid level be expected to drop after a 5-minute pumping test if the diameter of the solution tank is 6 ft?
- 5.335 The desired chemical pumping rate has been calculated to be 20 gpm. If the maximum pumping rate is 90 gpm, what should the percent stroke setting be?
- 5.336 What should the chlorinator setting be in pounds per day to treat a flow of 4.3 MGD if the chlorine demand is 8.7 mg/L and a chlorine residual of 0.9 mg/L is desired?
- 5.337 The average chemical use at a plant is 90 lb/day. If the chemical inventory in stock is 2100 lb, how many days' supply is this?
- 5.338 The desired solution feed rate was calculated to be 50 gpd. What is this feed rate expressed as milliliters per minute?
- 5.339 A calibration test is conducted for a solution chemical feeder. During a 5-minute test, the pump delivered 888 mL of the 0.9% polymer solution. What is the polymer dosage rate in pounds per day? Assume that the polymer solution weighs 8.34 lb/gal.
- 5.340 The flow to be treated is 3,220,000 gpd. The optimum polymer dose has been determined to be 9 mg/L. If the solution to be used contains 60% active polymer, what should the solution chemical feeder setting be in milliliters per minute?

- 5.341 A pumping calibration test is conducted for a 3-minute period. The liquid level in the 4-ft-diameter solution tank is measured before and after the test. If the level drops 15 in. during the 3-minute test, what is the pumping rate in gallons per minute?
- 5.342 A wastewater flow of 3,115,000 gpd requires a chlorine dose of 11.1 mg/L. If hypochlorite (65% available chlorine) is to be used, how many pounds per day of hypochlorite are required?
- 5.343 If 6 gal of a 12% strength solution are mixed with 22 gal of a 0.3% strength solution, what is the percent strength of the solution mixture? Assume that the 12% solution weighs 11.2 lb/gal and the 0.3% solution weighs 8.34 lb/gal.

5.9 SLUDGE PRODUCTION AND THICKENING

5.9.1 Primary and Secondary Clarifier Solids Production

- 5.344 A primary clarifier receives a flow of 4.82 MGD with a suspended solids concentration of 291 mg/L. If the clarifier effluent has a suspended solids concentration of 131 mg/L, how many pounds of dry solids are generated daily?
- 5.345 The suspended solids concentration of the primary influent is 315 mg/L and that of the primary effluent is 131 mg/L. How many pounds of dry solids are produced if the flow is 3.9 MGD?
- 5.346 The 2.1-MGD influent to the secondary system has a BOD concentration of 260 mg/L. The secondary effluent contains 125 mg/L BOD. If the bacterial growth rate (Y -value) for this plant is 0.6 lb SS/lb BOD removed, how many pounds of dry solids are produced each day by the secondary system?
- 5.347 The y -value for a treatment plant secondary system is 0.66 lb SS/lb BOD removed. The influent to the secondary system is 2.84 MGD. If the BOD concentration of the secondary influent is 288 mg/L and the effluent BOD is 131 mg/L, how many pounds of dry solids are produced each day by the secondary system?

5.9.2 Percent Solids and Sludge Pumping

- 5.348 The total weight of a sludge sample is 31 g (sludge sample only, not the dish). If the weight of the solids after drying is 0.71 g, what is the percent total solids of the sludge?
- 5.349 A total of 8520 lb/day suspended solids is removed from a primary clarifier and pumped to a sludge thickener. If the sludge has a solids content of 4.2%, how many pounds per day sludge are pumped to the thickener?
- 5.350 A total of 9350 gal of sludge is pumped to a digester. If the sludge has a 5.5% solids content, how many pounds per day solids are pumped to the digester? Assume that the sludge weighs 8.34 lb/gal.

- 5.351 It is anticipated that 1490 pounds per day suspended solids will be pumped from the primary clarifier of a new plant. If the primary clarifier sludge has a solids content of 5.3%, how many gallons per day sludge will be pumped from the clarifier? Assume that the sludge weighs 8.34 lb/gal.
- 5.352 A primary sludge has a solids content of 4.4%. If 900 lb/day suspended solids are pumped from the primary clarifier, how many gallons per day sludge will be pumped from the clarifier? Assume that the sludge weighs 8.34 lb/gal.
- 5.353 A total of 20,100 lb/day sludge is pumped to a thickener. The sludge has 4.1% solids content. If the sludge is concentrated to 6% solids, what will be the expected pounds per day sludge flow from the thickener?
- 5.354 A primary clarifier sludge has 5.1% solids content. If 2910 gpd of primary sludge is pumped to a thickener and the thickened sludge has a solids content of 6%, what would be the expected flow of thickened sludge in gallons per day? Assume that the primary sludge weighs 8.34 lb/gal and the thickened sludge weighs 8.64 lb/gal.
- 5.355 A primary clarifier sludge has 3.4% solids content. A total of 12,400 lb/day sludge is pumped to a thickener. If the sludge has been concentrated to 5.4% solids, what will be the sludge flow rate from the thickener in pounds per day?
- 5.356 The sludge from a primary clarifier has a solids content of 4.1%. The primary sludge is pumped at a rate of 6100 gpd to a thickener. If the thickened sludge has a solids content of 6.4%, what is the anticipated sludge flow through the thickener in gallons per day? Assume that the primary sludge weighs 8.34 lb/gal and the secondary sludge weighs 8.6 lb/gal.

5.9.3 Gravity Thickening

- 5.357 A gravity thickener 28 ft in diameter receives a flow of 70 gpm primary sludge combined with a secondary effluent flow of 82 gpm. What is the hydraulic loading on the thickener in gallons per day per square foot?
- 5.358 The primary sludge flow to a gravity thickener is 90 gpm. This is blended with a 72-gpm secondary effluent flow. If the thickener has a diameter of 28 ft, what is the hydraulic loading rate in gallons per day per square foot?
- 5.359 A primary sludge flow equivalent to 122,000 gpd is pumped to a 44-ft-diameter gravity thickener. If the solids concentration of the sludge is 4.1%, what is the solids loading in pounds per day per square foot?
- 5.360 What is the solids loading on a gravity thickener in pounds per day per square foot if the primary sludge flow to the 32-ft-diameter gravity thickener is 60 gpm with a solids concentration of 3.8%.

- 5.361 A gravity thickener 46 ft in diameter has a sludge blanket depth of 3.8 ft. If sludge is pumped from the bottom of the thickener at the rate of 28 gpm, what is the sludge detention time in the thickener in days?
- 5.362 A gravity thickener 40 ft in diameter has a sludge blanket depth of 4.3 ft. If the sludge is pumped from the bottom of the thickener at a rate of 31 gpm, what is the sludge detention time in the thickener in hours?
- 5.363 What is the efficiency of the gravity thickener if the influent flow to the thickener has a sludge solids concentration of 4% and the effluent flow has a sludge solids concentration of 0.9%?
- 5.364 The sludge flow entering a gravity thickener contains 3.5% sludge solids. The effluent from the thickener contains 0.8% sludge solids. What is the efficiency of the gravity thickener in removing sludge solids?
- 5.365 The sludge solids concentration of the influent flow to a gravity thickener is 3.3%. If the sludge withdrawn from the bottom of the thickener has a sludge solids concentration of 8.4%, what is the concentration factor?
- 5.366 The influent flow to a gravity thickener has a sludge solids concentration of 3.1%. What is the concentration factor if the sludge solids concentration of the sludge withdrawn from the thickener is 8.0%?
- 5.367 Given the data below, determine whether the sludge blanket in the gravity thickener is expected to increase, decrease, or remain the same:
- Sludge pumped to thickener = 130 gpm
- Thickener sludge pumped from thickener = 50 gpm
- Primary sludge solids = 3.6%
- Thickened sludge solids = 8.1%
- Thickener effluent suspended solids = 590 mg/L
- 5.368 Given the data below, determine whether the sludge blanket in the gravity thickener is expected to increase, decrease, or remain the same. If there is an increase or decrease, how many pounds per day should this change be?
- Sludge pumped to thickener = 110 gpm
- Thickener sludge pumped from thickener = 65 gpm
- Primary sludge solids = 3.6%
- Thickened sludge solids = 7.1%
- Thickener effluent suspended solids = 520 mg/L
- 5.369 If solids are being stored at a rate of 9400 lb/day in a 30-ft-diameter gravity thickener, how many hours will it take the sludge blanket to rise 1.8 ft? The thickened sludge solids concentration is 6.6%.

- 5.370 Solids are being stored at a rate of 14,000 lb/day in a 30-ft-diameter gravity thickener. How many hours will it take the sludge blanket to rise 2.5 ft? The thickened sludge solids concentration is 8%.
- 5.371 After several hours of startup of a gravity thickener, the sludge blanket level is measured at 2.6 ft. The desired sludge blanket level is 6 ft. If the sludge solids are entering the thickener at a rate of 60 lb/min, what is the desired sludge withdrawal rate in gallons per minute? The thickened sludge solids concentration is 5.6%.
- 5.372 The sludge blanket level is measured at 3.3 ft after several hours of startup of a gravity thickener. If the desired sludge blanket level is 7 ft and the sludge solids are entering the thickener at the rate of 61 lb/min, what is the desired sludge withdrawal rate in gallons per minute? The thickened sludge solids concentration is 5.6%.

5.9.4 Dissolved Air Flotation (DAF) Thickening

- 5.373 A dissolved air flotation thickener receives a sludge flow of 910 gpm. If the DAF unit is 40 ft in diameter, what is the hydraulic loading rate in gallons per minute per square foot?
- 5.374 A dissolved air flotation thickener 30 ft in diameter receives a sludge flow of 660 gpm. What is the hydraulic loading rate in gallons per minute per square foot?
- 5.375 The sludge flow to a 40-ft-diameter dissolved air thickener is 170,000 gpd. If the influent waste activated sludge has a suspended solids concentration of 8420 mg/L, what is the solids loading rate in pounds per hour per square foot? Assume that the sludge weighs 8.34 lb/gal.
- 5.376 The sludge flow to a dissolved air flotation thickener is 120 gpm with a suspended solids concentration of 0.7%. If the DAF unit is 65 ft long by 20 ft wide, what is the solids loading rate in pounds per hour per square foot? Assume that the sludge weighs 8.34 lb/gal.
- 5.377 The air rotameter indicates that 9 cfm is being supplied to the dissolved air flotation thickener. What is this air supply expressed as pounds per hour?
- 5.378 The air rotameter for the dissolved air flotation thickener indicates that 12 cfm is being supplied to the DAF unit. What is this air supply expressed as pounds per hour?
- 5.379 A dissolved air flotation thickener receives an 85-gpm flow of waste activated sludge with a solids concentration of 8600 mg/L. If air is supplied at a rate of 8 cfm, what is the air-to-solids ratio?
- 5.380 The sludge flow to a dissolved air flotation thickener is 60 gpm with a suspended solids concentration of 7800 mg/L. If the air supplied to the DAF unit is 5 cfm, what is the air-to-solids ratio?
- 5.381 A dissolved air flotation thickener receives a sludge flow of 85 gpm. If the recycle rate is 90 gpm, what is the percent recycle rate?

- 5.382 The desired percent recycle rate for a dissolved air flotation unit is 112%. If the sludge flow to the thickener is 70 gpm, what should the recycle flow be in million gallons per day?
- 5.383 An 80-ft-diameter DAF thickener receives a sludge flow with a solids concentration of 7700 mg/L. If the effluent solids concentration is 240 mg/L, what is the solids removal efficiency?
- 5.384 The solids concentration of the influent sludge to a dissolved air flotation unit is 8410 mg/L. If the thickened sludge solids concentration is 4.8%, what is the concentration factor?

5.9.5 Centrifuge Thickening

- 5.385 A disc centrifuge receives a waste activated sludge flow of 40 gpm. What is the hydraulic loading on the unit in gallons per hour?
- 5.386 The waste activated sludge flow to a scroll centrifuge thickener is 86,400 gpd. What is the hydraulic loading on the thickener in gallons per hour?
- 5.387 The waste activated sludge flow to a basket centrifuge is 70 gpm. The basket run time is 30 minutes until the basket is full of solids. If it takes 1 minute to skim the solids out of the unit, what is the hydraulic loading rate on the unit in gallons per hour?
- 5.388 The sludge flow to a basket centrifuge is 78,000 gpd. The basket run time is 25 minutes until the flow to the unit must be stopped for the skimming operation. If skimming takes 2 minutes, what is the hydraulic loading on the unit in gallons per hour?
- 5.389 A scroll centrifuge receives a waste activated sludge flow of 110,000 gpd with a solids concentration of 7600 mg/L. What is the solids loading to the centrifuge in pounds per hour?
- 5.390 The sludge flow to a basket thickener is 80 gpm with a solids concentration of 7500 mg/L. The basket operates 30 minutes before the flow must be stopped to the unit for the 2-minute skimming operation. What is the solids loading to the centrifuge in pounds per hour?
- 5.391 A basket centrifuge with a 32-ft³ capacity receives a flow of 70 gpm. The influent sludge solids concentration is 7400 mg/L. The average solids concentration within the basket is 6.6%. What is the feed time for the centrifuge in minutes?
- 5.392 A basket centrifuge thickener has a capacity of 22 ft³. The 55-gpm sludge flow to the thickener has a solids concentration of 7600 mg/L. The average solids concentration within the basket is 9%. What is the feed time for the centrifuge in minutes?
- 5.393 The influent sludge solids concentration to a disc centrifuge is 8000 mg/L. If the sludge solids concentration of the centrifuge effluent (centrate) is 800 mg/L, what is the sludge solids removal efficiency?

- 5.394 Influent sludge to a scroll centrifuge has a sludge solids concentration of 9200 mg/L. If the centrifuge effluent has a sludge solids concentration of 0.25%, what is the sludge solids removal efficiency?
- 5.395 A total of 16 ft³ of skimmed sludge and 4.0 ft³ of knifed sludge is removed from a basket centrifuge. If the skimmed sludge has a solids concentration of 4.4% and the knifed sludge has a solids concentration of 8.0%, what is the percent solids concentration of the sludge mixture?
- 5.396 A total of 12 ft³ of skimmed sludge and 4 ft³ of knifed sludge is removed from a basket centrifuge. If the skimmed sludge has a solids concentration of 3.8% and the knifed sludge has a solids concentration of 8.0%, what is the percent solids concentration of the sludge mixture?

5.9.6 General Sludge Production and Thickening Calculations

- 5.397 A solid bowl centrifuge receives 48,400 gal of sludge daily. The sludge concentration before thickening is 0.8. How many pounds of solids are received each day?
- 5.398 A gravity thickener receives a primary sludge flow rate of 170 gpm. If the thickener has a diameter of 24 ft, what is the hydraulic loading rate in gallons per day per square foot?
- 5.399 The primary sludge flow rate to a 40-ft-diameter gravity thickener is 240 gpm. If the solids concentration is 1.3%, what is the solids loading rate in pounds per square foot?
- 5.400 Waste activated sludge is pumped to a 34-ft-diameter dissolved air flotation thickener at a rate of 690 gpm. What is the hydraulic loading rate in gallons per minute per square foot?
- 5.401 Waste activated sludge is pumped to a 30-ft-diameter dissolved air flotation thickener at a rate of 130 gpm. If the concentration of solids is 0.98%, what is the solids loading rate in pounds per hour per square foot?
- 5.402 The suspended solids content of the primary influent is 305 mg/L and that of the primary effluent is 121 mg/L. How many pounds of solids are produced during a day when the flow is 3.5 MGD?
- 5.403 The total weight of a sludge sample is 32 g (sample weight only, not including the weight of the dish). If the weight of the solids after drying is 0.66 g, what is the percent total solids of the sludge?
- 5.404 A primary clarifier sludge has 3.9% solids content. If 3750-gpd primary sludge is pumped to a thickener and the thickened sludge has a solids content of 8%, what would be the expected flow of thickened sludge in gallons per day? Assume that both sludges weigh 8.34 lb/gal.
- 5.405 A total of 9550 gal of sludge is pumped to a digester daily. If the sludge has a 4.9% solids content, how many pounds per day solids are pumped to the digester? Assume that the sludge weighs 8.34 lb/gal.

- 5.406 The 2.96-MGD influent to a secondary system has a BOD concentration of 170 mg/L. The secondary effluent contains 38 mg/L BOD. If the bacteria growth rate (y -value) for this plant is 0.5 lb SS/lb BOD removed, what is the estimated total pounds of dry solids produced each day by the secondary system?
- 5.407 A gravity thickener 42 ft in diameter has a sludge blanket depth of 5 ft. If sludge is pumped from the bottom of the thickener at the rate of 32 gpm, what is the sludge detention time in the thickener in hours?
- 5.408 The solids concentration of the influent flow to a gravity thickener is 3.1%. If sludge withdrawn from the bottom of the thickener has a solids concentration of 7.7%, what is the concentration factor?
- 5.409 The sludge flow to a 36-ft-diameter dissolved air thickener is 140,000 gpd. If the influent waste activated sludge has a suspended solids concentration of 7920 mg/L, what is the solids loading rate in pounds per hour per square foot?
- 5.410 A 75-ft-diameter DAF thickener receives a sludge flow with a solids concentration of 7010 mg/L. If the effluent solids concentration is 230 mg/L, what is the solids removal efficiency?
- 5.411 The primary sludge flow to a gravity thickener is 70 gpm. This is blended with a 100-gpm secondary effluent flow. If the thickener has a diameter of 30 ft, what is the hydraulic loading rate in gallons per day per square foot?
- 5.412 What is the efficiency of a gravity thickener if the influent flow to the thickener has a sludge solids concentration of 3.3% and the effluent flow has a sludge solids concentration of 0.3%.
- 5.413 The air supplied to a dissolved air flotation thickener is 9 cfm. What is this air supply expressed as pounds per hour?
- 5.414 Given the data below, determine whether the sludge blanket in the gravity thickener will increase, decrease, or remain the same:
- Sludge pumped to thickener = 110 gpm
- Thickened sludge pumped from thickener = 50 gpm
- Primary sludge solids = 4%
- Thickened sludge solids = 7.7%
- Thickener effluent suspended solids = 700 mg/L
- 5.415 What is the solids loading on a gravity thickener in pounds per day per square foot, if the primary sludge flow to the 32-ft-diameter thickener is 60 gpm with a solids concentration of 4.1%?
- 5.416 A dissolved air flotation unit is 60 ft long by 14 ft wide. If the unit receives a sludge flow of 190,000 gpd, what is the hydraulic loading rate in gallons per minute per square foot?
- 5.417 If solids are being stored at a rate of 9400 lb/day in a 26-ft-diameter gravity thickener, how many hours will it take the sludge blanket to rise 2.6 ft? The solids concentration of the thickened sludge is 6.9%.

- 5.418 The waste activated sludge flow to a scroll centrifuge thickener is 84,000 gpd. What is the hydraulic loading rate on the thickener in gallons per hour?
- 5.419 The sludge flow to a dissolved air flotation thickener is 110 gpm. The solids concentration of the sludge is 0.81%. If the air supplied to the DAF unit is 6 cfm, what is the air-to-solids ratio?
- 5.420 The desired percent recycle for a DAF unit is 112%. If the sludge flow to the thickener is 74 gpm, what should the recycle flow be in million gallons per day?
- 5.421 The sludge flow to a basket centrifuge is 79,000 gpd. The basket run time is 32 minutes until flow to the unit must be stopped for the skimming operation. If skimming takes 2 minutes, what is the hydraulic loading on the unit in gallons per hour?
- 5.422 After several hours of startup of a gravity thickener, the sludge blanket level is measured at 2.5 ft. The desired sludge blanket level is 6 ft. If the sludge solids are entering the thickener at a rate of 48 lb/min, what is the desired sludge withdrawal rate in gallons per minute? The thickened sludge solids concentration is 8%.
- 5.423 A scroll centrifuge receives a waste activated sludge flow of 110,000 gpd with a solids concentration of 7110 mg/L. What is the solids loading to the centrifuge in pounds per hour?
- 5.424 A basket centrifuge with a 34 ft³ capacity receives a flow of 70 gpm. The influent sludge solids concentration is 7300 mg/L. The average solids concentration within the basket is 6.6%. What is the feed time for the centrifuge in minutes?
- 5.425 The sludge flow to a basket thickener is 100 gpm with a solids concentration of 7900 mg/L. The basket operates 24 minutes before the flow must be stopped to the unit during the 1.5-minute skimming operation. What is the solids loading to the centrifuge in pounds per hour?
- 5.426 A total of 12 ft³ of skimmed sludge and 5 ft³ of knifed sludge is removed from a basket centrifuge. The skimmed sludge has a solids concentration of 3.9%; the knifed sludge has a solids concentration of 7.8%. What is the solids concentration of the sludge mixture?

5.10 DIGESTION

5.10.1 Mixing Different Sludge Mixtures

- 5.427 A primary sludge flow of 4240 gpd with a solids content of 5.9% is mixed with a thickened secondary sludge flow of 6810 gpd with a solids content of 3.5%. What is the percent solids content of the mixed sludge flow? Assume that both sludges weigh 8.34 lb/gal.
- 5.428 Primary and thickened secondary sludges are to be mixed and sent to the digester. The 3510-gpd primary sludge has a solids content of 5.2% and the 5210-gpd thickened secondary sludge has a solids content of 4.1%. What would be the percent solids content of the mixed sludge? Assume that both sludges weigh 8.3 lb/gal.

- 5.429 A primary sludge flow of 3910 gpd with a solids content of 6.3% is mixed with a thickened secondary sludge flow of 6690 gpd with a solids content of 4.9%. What is the percent solids of the combined sludge flow? Assume that both sludges weigh 8.34 lb/gal.
- 5.430 Primary and secondary sludges are to be mixed and sent to the digester. The 2510-gpd primary sludge has a solids content of 4.3%, and the 3600 gpd thickened secondary sludge has a solids content of 6.1%. What would be the percent solids content of the mixed sludge? Assume that the 4.3% sludge weighs 8.35 lb/gal and the 6.1% sludge weighs 8.60 lb/gal.

5.10.2 Sludge Volume Pumped

- 5.431 A piston pump discharges a total of 0.9 gal per stroke. If the pump operates at 30 strokes per minute, what is the pumping rate in gallons per minute? Assume that the piston is 100% efficient and displaces 100% of its volume each stroke.
- 5.432 A sludge pump has a bore of 10 in. and a stroke length of 3 in. If the pump operates at 30 strokes per minute, how many gallons per minute are pumped? Assume 100% efficiency.
- 5.433 A sludge pump has a bore of 8 in. and a stroke setting of 3 in. The pump operates at 32 strokes per minute. If the pump operates a total of 120 minutes during a 24-hr period, what is the pumping rate in gallons per day? Assume 100% efficiency.
- 5.434 A sludge pump has a bore of 12 in. and a stroke setting of 4 in. The pump operates at 32 strokes per minute. If the pump operates a total of 140 minutes during a 24-hr period, what is the pumping rate in gallons per day? Assume 100% efficiency.

5.10.3 Sludge Pump Operating Time

- 5.435 The flow to a primary clarifier is 2.5 MGD. The influent suspended solids concentration is 240 mg/L, and the effluent suspended solids concentration is 110 mg/L. If the sludge to be removed from the clarifier has a solids content of 3.5% and the sludge pumping rate is 32 gpm, how many minutes per hour should the pump operate?
- 5.436 The suspended solids concentration of the 1,870,000-gpd influent flow to a primary clarifier is 210 mg/L. The suspended solids concentration in the primary clarifier effluent flow is 90 mg/L. If the sludge to be removed from the clarifier has a solids content of 3.6% and the sludge pumping rate is 28 gpm, how many minutes per hour should the pump operate?
- 5.437 A primary clarifier receives a flow of 3,480,000 gpd with a suspended solids concentration of 220 mg/L. The clarifier effluent has a suspended solids concentration of 96 mg/L. If the sludge to be removed from the clarifier has a solids content of 4.0%, and the sludge pumping rate is 38 gpm, how many minutes per hour should the pump operate?

- 5.438 The flow to a primary clarifier is 1.5 MGD with a suspended solids concentration of 222 mg/L. The clarifier effluent suspended solids concentration is 92 mg/L. The sludge to be removed from the clarifier has a solids content of 3.2%. If the sludge pumping rate is 32 gpm, how many minutes per hour should the pump operate?

5.10.4 Volatile Solids to the Digester

- 5.439 If 8620 lb/day of solids with a volatile solids content of 66% are sent to the digester, how many pounds per day volatile solids are sent to the digester?
- 5.440 If 2810 lb/day of solids with a volatile solids content of 67% are sent to the digester, how many pounds per day volatile solids are sent to the digester?
- 5.441 A total of 3720 gpd of sludge is to be pumped to the digester. If the sludge has a 5.8% solids content with 70% volatile solids, how many pounds per day volatile solids are pumped to the digester? Assume that the sludge weighs 8.34 lb/gal.
- 5.442 The sludge has a 7% solids content with 67% volatile solids. If a total of 5115 gpd of sludge is to be pumped to the digester, how many pounds per day volatile solids are pumped in the digester?

5.10.5 Seed Sludge Calculation

- 5.443 A digester has a capacity of 295,200 gal. If the digester seed sludge is to be 25% of the digester capacity, how many gallons of seed sludge will be required?
- 5.444 A 40-ft-diameter digester has a side water depth of 24 ft. If the seed sludge to be used is 21% of the tank capacity, how many gallons of seed sludge will be required?
- 5.445 A 50-ft-diameter digester has a side water depth of 20 ft. If 62,200 gal of seed sludge are to be used in starting up the digester, what percent of the digester volume will be seed sludge?
- 5.446 A digester 40 ft in diameter has a side water depth of 18 ft. If the digester seed sludge is to be 20% of the digester capacity, how many gallons of seed sludge will be required?
- 5.447 A total of 66,310 lb/day of sludge is pumped to a 120,000-gal digester, and the sludge has a total solids content of 5.3% and volatile solids content of 70%. The sludge in the digester has a solids content of 6.3% with a 56% volatile solids content. What is the volatile solids loading on the digester in the volatile solids added per day per pound volatile solids in the digester?
- 5.448 A total of 22,310 gal of digested sludge is in a digester. The digested sludge contains 6.2% total solids and 55% volatile solids. To maintain a volatile solids loading ratio of 0.06 lb volatile solids added per day per pound volatile solids under digestion, how many pounds volatile solids may enter the digester daily?

- 5.449 A total of 60,400 lb/day sludge is pumped to a 96,000-gal digester. The sludge pumped to the digester has a total solids content of 5.4% and a volatile solids content of 67%. The sludge in the digester has a solids content of 5% with a 58% volatile solids content. What is the volatile solids loading on the digester in pounds volatile solids added per day per pound volatile solids in the digester?
- 5.450 The raw sludge flow to the new digester is expected to be 900 gpd. The raw sludge contains 5.5% solids and 69% volatile solids. The desired volatile solids loading ratio is 0.07 lb volatile solids added per day per pound volatile solids in the digester. How many gallons of seed sludge will be required if the seed sludge contains 8.2% solids with a 52% volatile solids content? Assume that the seed sludge weighs 8.80 lb/gal.

5.10.6 Digester Loading Rate

- 5.451 A digester 50 ft in diameter with a water depth of 22 ft receives 86,100 lb/day raw sludge. If the sludge contains 5% solids with 70% volatile matter, what is the digester loading in pounds volatile solids added per day per cubic foot of volume?
- 5.452 What is the digester loading in pounds volatile solids added per day per 1000 ft³ if a digester, 40 ft in diameter with a liquid level of 22 ft, receives 28,500 gpd of sludge with 5.5% solids and 72% volatile solids? Assume that the sludge weighs 8.34 lb/gal.
- 5.453 A digester 50 ft in diameter with a liquid level of 20 ft receives 36,220 gpd of sludge with 5.6% solids and 68% volatile solids. What is the digester loading in pounds volatile solids added per day per 1000 ft³? Assume that the sludge weighs 8.34 lb/gal.
- 5.454 A digester, 50 ft in diameter with a liquid level of 18 ft, receives 16,200-gpd sludge with 5.1% solids and 72% volatile solids. What is the digester loading in pounds volatile solids added per day per 1000 ft³?

5.10.7 Stored Digester Sludge

- 5.455 A total of 2600 gpd sludge is pumped to a digester. If the sludge has a total solids content of 5.7% and a volatile solids concentration of 66%, how many pounds of digested sludge should be in the digester for this load? Assume that the sludge weighs 8.34 lb/gal. Use a ratio of 1 lb volatile solids added per day per 10 lb of digested sludge.
- 5.456 A total of 6300 gpd of sludge is pumped to a digester. The sludge has a solids concentration of 5% and a volatile solids content of 70%. How many pounds of digested sludge should be in the digester for this load? Assume that the sludge weighs 8.34 lb/gal. Use a ratio of 1 lb volatile solids added per day per 10 lb of digested sludge.

- 5.457 The sludge pumped to a digester has a solids concentration of 6.5% and a volatile solids content of 67%. If a total of 5200 gpd of sludge is pumped to the digester, how many pounds of digested sludge should be in the digester for this load? Assume that the sludge weighs 8.34 lb/gal. Use a ratio of 1 lb volatile solids added per day per 10 lb of digested sludge.
- 5.458 A digester receives a flow of 3800 gal of sludge during a 24-hr period. If the sludge has a solids content of 6% and a volatile solids concentration of 72%, how many pounds of digested sludge should be in the digester for this load? Assume that the sludge weighs 8.34 lb/gal. Use a ratio of 1 lb volatile solids added per day per 10 lb of digested sludge.

5.10.8 Volatile Acids/Alkalinity Ratio

- 5.459 The volatile acids concentration of the sludge in the anaerobic digester is 174 mg/L. If the measured alkalinity is 2220 mg/L, what is the volatile acids/alkalinity ratio?
- 5.460 The volatile acids concentration of the sludge in the anaerobic digester is 160 mg/L. If the measured alkalinity is 2510 mg/L, what is the volatility acids/alkalinity ratio?
- 5.461 The measured alkalinity is 2410 mg/L. If the volatile acids concentration of the sludge in the anaerobic digester is 144 mg/L, what is the volatile acids/alkalinity ratio?
- 5.462 The measured alkalinity is 2620 mg/L. If the volatile acids concentration of the sludge in the anaerobic digester is 178 mg/L, what is the volatile acids/alkalinity ratio?

5.10.9 Lime Neutralization

- 5.463 To neutralize a sour digester, 1 mg/L of lime is to be added for every 1 mg/L of volatile acids in the digester sludge. If the digester contains 244,000 gal of sludge with a volatile acids level of 2280 mg/L, how many pounds of lime should be added?
- 5.464 To neutralize a sour digester, 1 mg/L of lime is to be added for every 1 mg/L of volatile acids in the digester sludge. If the digester contains 200,000 gal of sludge with a volatile acids level of 2010 mg/L, how many pounds of lime should be added?
- 5.465 The digester contains 234,000 gal of sludge with a volatile acids level of 2540 mg/L. To neutralize a sour digester, 1 mg/L of lime is to be added for every 1 mg/L of volatile acids in the digester sludge. How many pounds of lime should be added?
- 5.466 The digester sludge is found to have a volatile acids content of 2410 mg/L. If the digester volume is 182,000 gal, how many pounds of lime will be required for neutralization?

5.10.10 Percent Volatile Solids Reduction

- 5.467 The sludge entering a digester has a volatile solids content of 68%. The sludge leaving the digester has a volatile solids content of 52%. What is the percent volatile solids reduction?
- 5.468 The sludge leaving the digester has a volatile solids content of 54%. The sludge entering a digester has a volatile solids content of 70%. What is the percent volatile solids reduction?
- 5.469 The raw sludge to a digester has a volatile solids content of 70%. The digested sludge volatile solids content is 53%. What is the percent volatile solids reduction?
- 5.470 The digested sludge volatile solids content is 54%. The raw sludge to a digester has a volatile solids content of 69%. What is the percent volatile solids reduction?

5.10.11 Volatile Solids Destroyed

- 5.471 A flow of 3800 gpd sludge is pumped to a 36,500-ft³ digester. The solids concentration of the sludge is 6.3% with a volatile solids content of 73%. If the volatile solids reduction during digestion is 57%, how many pounds per day volatile solids are destroyed per cubic foot of digester capacity? Assume that the sludge weighs 8.34 lb/gal.
- 5.472 A flow of 4520 gpd sludge is pumped to a 34,000-ft³ digester. The solids concentration of the sludge is 7% with a volatile solids content of 69%. If the volatile solids reduction during digestion is 54%, how many pounds per day volatile solids are destroyed per cubic foot of digester capacity? Assume that the sludge weighs 8.34 lb/gal.
- 5.473 A 50-ft-diameter digester receives a sludge flow of 2600 gpd with a solids content of 5.6% and a volatile solids concentration of 72%. The volatile solids reduction during digestion is 52%. The digester operates at a level of 18 ft. What is the pounds per day volatile solids reduction per cubic foot of digester capacity? Assume that the sludge weighs 8.34 lb/gal.
- 5.474 The sludge flow to a 40-ft-diameter digester is 2800 gpd with a solids concentration of 6.1% and a volatile solids concentration of 65%. The digester is operated at a depth of 17 ft. If the volatile solids reduction during digestion is 56%, what is the pounds per day volatile solids reduction per 1000 ft³ of digester capacity? Assume that the sludge weighs 8.34 lb/gal.

5.10.12 Digester Gas Production

- 5.475 A digester gas meter reading indicates that an average of 6600 ft³ of gas is produced per day. If a total of 500 lb/day volatile solids is destroyed, what is the digester gas production in cubic feet gas per pound volatile solids destroyed?

- 5.476 A total of 2110 lb of volatile solids is pumped to the digester daily. If the percent reduction of volatile solids due to digestion is 59% and the average gas production of the day is 19,330 ft³, what is the daily gas production in cubic feet per pound volatile solids destroyed?
- 5.477 A total of 582 lb/day volatile solids is destroyed. If a digester gas meter reading indicates an average of 8710 ft³ of gas is produced per day, what is the digester gas production in cubic feet per pound volatile solids destroyed?
- 5.478 The percent reduction of volatile solids due to digestion is 54% and the average gas production for the day is 26,100 ft³. If a total of 3320 lb of volatile solids is pumped to the digester daily, what is the daily gas production in cubic feet per pound volatile solids destroyed?

5.10.13 Digestion Time

- 5.479 A 40-ft-diameter aerobic digester has a side water depth of 12 ft. The sludge flow to the digester is 9100 gpd. Calculate the hydraulic digestion time in days.
- 5.480 An aerobic digester 40 ft in diameter has a side water depth of 10 ft. The sludge flow to the digester is 8250 gpd. Calculate the hydraulic digestion time in days.
- 5.481 An aerobic digester is 80 ft long by 25 ft wide and has a side water depth of 12 ft. If the sludge flow to the digester is 7800 gpd, what is the hydraulic digestion time in days?
- 5.482 Sludge flow of 11,000 gpd has a solids content of 3.4%. Thickening reduces the sludge flow to 5400 gpd with a 5% solids content. Compare the digestion times for the two different sludge flows to a digester 30 ft in diameter with a side water depth of 12 ft.

5.10.14 Air Supply Requirements

- 5.483 The desired air supply rate for an aerobic digester was determined to be 0.06 cfm/ft³ digester capacity. What is the total air required in cubic feet per minute if the digester is 90 ft long by 30 ft wide with a side water depth of 12 ft?
- 5.484 An aerobic digester is 70 ft in diameter with a side water depth of 10 ft. If the desired air supply for this digester was determined to be 40 cfm/1000 ft³ digester capacity, what is the total air required for this digester in cubic feet per minute?
- 5.485 The dissolved air concentrations recorded during a 5-minute test of an air-saturated sample of aerobic digester sludge are given below. Calculate the oxygen uptake in milligrams per liter per hour.

Elapsed time	DO (mg/L)	Elapsed time	DO (mg/L)
At start	6.5	3 minutes	4.5
1 minute	5.9	4 minutes	3.9
2 minutes	5.4	5 minutes	3.4

- 5.486 The dissolved air concentrations recorded during a 5-minute test of an air-saturated sample of aerobic digester sludge are given below. Calculate the oxygen uptake in milligrams per liter per hour.

Elapsed time	DO (mg/L)	Elapsed time	DO (mg/L)
At start	7.3	3 minutes	4.3
1 minute	6.8	4 minutes	4.2
2 minutes	5.7	5 minutes	3.6

5.10.15 pH Adjustments

- 5.487 Jar tests indicate that 22 mg of caustic are required to raise the pH of the 1-L sludge sample to 6.8. If the digester volume is 106,000 gal, how many pounds of caustic will be required for the pH adjustment?
- 5.488 Jar tests indicate that 16 mg of caustic are required to raise the pH of the 1-L sludge sample to 6.8. If the digester volume is 148,000 gal, how many pounds of caustic will be required for pH adjustment?
- 5.489 A 2-L sample of digester sludge is used to determine the required caustic dosage for pH adjustment. If 64 mg of caustic are required for pH adjustment in the jar test and the digester volume is 54,000 gal, how many pounds of caustic will be required for pH adjustment?
- 5.490 A 2-L sample of digested sludge is used to determine the required dosage for pH adjustment. A total of 90 mg caustic was used in the jar test. The aerobic digester is 60 ft in diameter with a side water depth of 14 ft. How many pounds of caustic are required for pH adjustment of the digester?

5.10.16 General Digester Calculations

- 5.491 Sludge is being pumped to the digester at a rate of 3.6 gpm. How many pounds of volatile solids are being pumped to the digester daily if the sludge has 5.1% total solids content with 71% volatile solids?
- 5.492 A 55-ft-diameter anaerobic digester has a liquid depth of 22 ft. The unit receives 47,200 gal of sludge daily with a solids content of 5.3%, of which 71% are volatile. What is the organic loading rate in the digester in pounds volatile solids added per cubic foot per day?
- 5.493 The concentration of volatile acids in the anaerobic digester is 181 mg/L. If the concentration of alkalinity is measured to be 2120 mg/L, what is the volatile acids/alkalinity ratio?
- 5.494 An anaerobic digester that becomes sour must be neutralized. Adding lime to the unit can do this. The amount of lime to add is determined by the ratio of 1 mg/L of lime for every 1 mg/L of volatile acids in the digester. If the volume of sludge in the digester is 756,000 L and the volatile acids concentration is 1820 mg/L, how many kilograms of lime will be required to neutralize the digester?

- 5.495 The anaerobic digester has a raw sludge volatile solids content of 67%. The digested sludge has a volatile solids content of 55%. What is the percent reduction in the volatile solids content through the anaerobic digester?
- 5.496 Calculations indicate that 2600 kg of volatile solids will be required in the seed sludge. How many liters of seed sludge will be required if the sludge has a 9.5% solids content with 66% volatile solids and weighs 1.14 kg/L?
- 5.497 A total of 8200 gpd sludge is pumped to a digester. If the sludge has a solids content of 5.7% and a volatile solids concentration of 65%, how many pounds of digested sludge should be in the digester for this load? Use a ratio of 1 lb volatile solids per day per 10 lb of digested sludge.
- 5.498 If 4400 lb/day solids with a volatile solids content of 67% are sent to the digester, how many pounds of volatile solids are sent to the digester daily?
- 5.499 What is the digester loading in pounds volatile solids added per day per 1000 ft³ if a digester 60 ft in diameter with a liquid level of 20 ft receives 12,900 gpd of sludge with 5.4% solids and 65% volatile solids?
- 5.500 A primary sludge flow of 4040 gpd with a solids content of 5.4% is mixed with a thickened secondary sludge flow of 5820 gpd with a solids content of 3.3%. What is the percent solids content of the mixed sludge flow? Assume that both sludges weigh 8.34 lb/gal.
- 5.501 A sludge pump has a bore or 8 in. and a stroke length of 6 in. The counter indicates a total of 3500 revolutions during a 24-hr period. What is the pumping rate in gpd? Assume 100% efficiency.
- 5.502 A 60-ft-diameter digester has a typical side water depth of 24 ft. If 88,200 gal of seed sludge are to be used in starting up the digester, what percent of the digester volume will be seed sludge?
- 5.503 A flow of 3800 gpd sludge is pumped to a 36,000-ft³ digester. The solids content of the sludge is 4.1% with a volatile solids content of 70%. If the volatile solids reduction during digestion is 54%, how many pounds per day volatile solids are destroyed per cubic foot of digester capacity? Assume that the sludge weighs 8.34 lb/gal.
- 5.504 The volatile acid concentration sludge in the anaerobic digester is 156 mg/L. If the measured alkalinity is 2310 mg/L, what is the volatile acids/alkalinity ratio?
- 5.505 To neutralize a sour digester, 1 mg/L of lime is to be added for every 1 mg/L of volatile acid in the digester sludge. If the digester contains 240,000 gal of sludge with a volatile acid level of 2240 mg/L, how many pounds of lime should be added?
- 5.506 A 50-ft-diameter digester has a typical water depth of 22 ft. If the seed sludge to be used is 24% of the tank capacity, how many gallons of seed sludge will be required?

- 5.507 A total of 4310 gpd of sludge is to be pumped to the digester. If the sludge has a 5.3% solids content with 72% volatile solids, how many pounds per day volatile solids are pumped to the digester? Assume that the sludge weighs 8.34 lb/gal.
- 5.508 Primary and thickened secondary sludges are to be mixed and sent to the digester. The 2940-gpd primary sludge has a solids content of 5.9%, and the 4720-gpd thickened secondary sludge has a solids content of 3.8%. What would be the percent solids content of the mixed sludge? Assume that both sludges weigh 8.34 lb/gal.
- 5.509 The measured alkalinity is 2470 mg/L. If the volatile acid concentration of the sludge in the anaerobic digester is 150 mg/L, what is the volatile acids/alkalinity ratio?
- 5.510 A total of 42,250 lb/day sludge is pumped to a 94,000-gal digester. The sludge being pumped to the digester has a total solids content of 4% and volatile solids content of 60%. The sludge in the digester has a solids content of 6.0% with a 55% volatile solids content. What is the volatile solids loading on the digester in pounds volatile solids added per day per lb volatile solids in the digester?
- 5.511 A sludge pump has a bore of 9 in. and a stroke length of 5 in. If the pump operates at 30 strokes per minute, how many gallons per minute are pumped? Assume 100% efficiency.
- 5.512 What is the digester loading in pounds volatile solids added per day per 1000 ft³ if a digester 40 ft in diameter with a liquid level of 21 ft receives 19,200 gpd of sludge with 5% solids and 66% volatile solids?
- 5.513 The digester sludge is found to have a volatile acids content of 2200 mg/L. If the digester volume is 0.3 MG, how many pounds of lime will be required for neutralization?
- 5.514 A digester gas meter reading indicates that an average of 6760 ft³ of gas is produced per day. If a total of 580 lb/day volatile solids is destroyed, what is the digester gas production in cubic feet gas per pound volatile solids destroyed?
- 5.515 The sludge entering a digester has a volatile solids content of 67%. The sludge leaving the digester has a volatile solids content of 52%. What is the percent volatile solids reduction?
- 5.516 The raw sludge flow to a new digester is expected to be 1230 gpd. The raw sludge contains 4.1% solids and 66% volatile solids. The desired volatile solids loading ratio is 0.09 lb volatile solids added per pound volatile solids in the digester. How many gallons of seed sludge will be required if the seed sludge contains 7.5% solids with a 55% volatile solids content? Assume that the raw sludge weighs 8.34 lb/gal and the seed sludge weighs 8.5 lb/gal.
- 5.517 The sludge leaving the digester has a volatile solids content of 56%. The sludge entering a digester has a volatile solids content of 70%. What is the percent volatile solids retention?
- 5.518 A 60-ft-diameter aerobic digester has a side water depth of 12 ft. The sludge flow to the digester is 9350 gpd. Calculate the digestion time in days.

- 5.519 A total of 2610 lb of volatile solids is pumped to the digester daily. The percent reduction of volatile solids due to digestion is 56% and the average gas production for the day is 22,400 ft³. What is the daily gas production in cubic feet per pound volatile solids destroyed?
- 5.520 The sludge flow to a 50-ft-diameter digester is 3200 gpd with a solids content of 6.4% and a volatile solids concentration of 68%. The digester is operated at a depth of 22 ft. If the volatile solids reduction during digestion is 55%, what is the pounds per day volatile solids reduction per 1000 ft³ of digester capacity?
- 5.521 The desired air supply rate for an aerobic digester is determined to be 0.05 cfm/ft³ digester capacity. What is the total cubic feet per minute of air required if the digester is 80 ft long by 20 ft wide and has a side water depth of 12 ft?
- 5.522 Jar testing indicates that 22 mg of caustic are required to raise the pH of the 1-L sample to 7.0. If the digester volume is 120,000 gal, how many pounds of caustic will be required for the pH adjustment?
- 5.523 Dissolved air concentration is taken on an air-saturated sample of digested sludge at 1-minute intervals. Given the results below, calculate the oxygen uptake in milligrams per liter per hour.

Elapsed time	DO (mg/L)	Elapsed time	DO (mg/L)
At start	7.7	3 minutes	5.2
1 minute	6.9	4 minutes	4.5
2 minutes	6.0	5 minutes	3.8

- 5.524 The flow to a primary clarifier is 2.2 MGD. The influent suspended solids concentration is 220 mg/L and the effluent suspended solids concentration is 101 mg/L. If the sludge to be removed from the clarifier has solids content of 3.0% and the sludge pumping rate is 25 gpm, how many minutes per hour should the pump operate?
- 5.525 A sludge flow of 12,000 gpd has a solids concentration of 2.6%. The solids concentration is increased to 4.6% as a result of thickening, and the reduced flow rate is 5400 gpd. Compare the digestion time for these two different sludge flows. The digester is 32 ft in diameter with a 24-ft operating depth.

5.11 SLUDGE DEWATERING

5.11.1 Filter Press Dewatering

- 5.526 A filter press used to dewater digested primary sludge receives a flow of 1100 gal over a 3-hr period. The sludge has a solids content of 3.8%. If the plate surface area is 140 ft², what is the solids loading rate in pounds per hour per square foot? Assume that the sludge weighs 8.34 lb/gal.
- 5.527 A filter press used to dewater digested primary sludge receives a flow of 820 gal over a 2-hr period. The solids content of the sludge is 5%. If the plate surface area is 160 ft², what is the solids loading rate in pounds per hour per square foot? Assume that the sludge weighs 8.34 lb/gal.

- 5.528 A plate-and-frame filter press receives solids loading of 0.80 lb/hr/ft². If the filtration time is 2 hr and the time required to remove the sludge cake and begin sludge feed to the press is 20 minutes, what is the net filter yield in pounds per hour per square foot?
- 5.529 A plate-and-frame filter press receives 680 gal of sludge over a 2-hr period. The solids concentration of the sludge is 3.9%. The surface area of the plate is 130 ft². If the down time for sludge cake discharge is 20 minutes, what is the net filter yield in pounds per hour per square foot? Assume that the sludge weighs 8.34 lb/gal.

5.11.2 Belt Filter Press Dewatering

- 5.530 A 6-ft-wide belt press receives a flow of 140 gpm of primary sludge. What is the hydraulic loading rate in gallons per minute per foot?
- 5.531 A belt filter press should dewater 21,300 lb of sludge per day. If the belt filter press will be operated 12 hr each day, what should the sludge feed rate to the press be in pounds per hour?
- 5.532 The amount of sludge to be dewatered by a belt filter press is 23,100 lb/day. If the maximum feed rate that still provides an acceptable cake is 1800 lb/hr, how many hours per day should the belt remain in operation?
- 5.533 The sludge feed to a belt filter press is 160 gpm. If the total suspended solids concentration of the feed is 4.4%, what is the solids loading rate in pounds per hour? Assume that the sludge weighs 8.34 lb/gal.
- 5.534 The flocculant concentration for a belt filter press is 0.7%. If the flocculant feed rate is 4 gpm, what is the flocculation feed rate in pounds per hour? Assume that the flow is steady and continuous and assume that the flocculant weighs 8.34 lb/gal.

5.11.3 Vacuum Filter Dewatering

- 5.535 Digested sludge is applied to a vacuum filter at a rate of 80 gpm, with a solids concentration of 5.1%. If the vacuum filter has a surface area of 320 ft², what is the filter loading in pounds per hour per square foot? Assume that the sludge weighs 8.34 lb/gal.
- 5.536 The wet cake flow from a vacuum filter is 6810 lb/hr. If the filter area is 320 ft² and the percent solids in the cake is 31%, what is the filter yield in pounds per hour per square foot?
- 5.537 A total of 5400 lb/day primary sludge solids is to be processed by a vacuum filter. The vacuum filter yield is 3.3 lb/hr/ft². The solids recovery is 90%. If the area of the filter is 230 ft², how many hours per day must the vacuum filter remain in operation to process this much solids?
- 5.538 The total pounds of dry solids pumped to a vacuum filter during a 24-hr period is 18,310 lb/day. The vacuum filter is operated 10 hr/day. If the percent solids recovery is 91% and the filter area is 265 ft², what is the filter yield in pounds per hour per square foot?

- 5.539 The sludge feed to a vacuum filter is 85,230 lb/hr, with a solids content of 5.9%. If the wet cake flow is 18,400 lb/hr with 20% solids content, what is the percent solids content and what is the percent solids recovery?

5.11.4 Sand Drying Bed Calculations

- 5.540 A drying bed is 210 ft long by 22 ft wide. If sludge is applied to a depth of 8 in., how many gallons of sludge are applied to the drying bed?
- 5.541 A drying bed is 240 ft long by 26 ft wide. If sludge is applied to a depth of 8 in., how many gallons of sludge are applied to the drying beds?
- 5.542 A sludge bed is 190 ft long by 20 ft wide. A total of 168,000 lb of sludge is applied during each application of the sand drying bed. The sludge has a solids content of 4.6%. If the drying and removal cycle requires 21 days, what is the solids loading rate in pounds per year per square foot?
- 5.543 A sludge drying bed is 220 ft long by 30 ft wide. The sludge is applied to a depth of 9 in. The solids concentration of the sludge is 3.9%. If the drying and removal cycle requires 25 days, what is the solids loading rate to the beds in pounds per year per square foot? Assume that the sludge weighs 8.34 lb/gallon.
- 5.544 Sludge is withdrawn from a digester that has a diameter of 50 ft. If the sludge is drawn down 2.4 ft, how many cubic feet will be sent to the drying beds?
- 5.545 A 50-ft-diameter digester has a drawdown of 14 in. If the drying bed is 70 ft long by 40 ft wide, how many feet deep will the drying be as a result of the drawdown?

5.11.5 Composting

- 5.546 If 4700 lb/day dewatered sludge with a solids content of 21% is mixed with 3800 lb/day compost with 26% moisture content, what is the percent moisture of the blend?
- 5.547 The total dewatered digested primary sludge produced at a plant is 4800 lb/day, with a solids content of 17%. The final compost to be used in blending has a moisture content of 27%. How much compost (in pounds per day) must be blended with the dewatered sludge to produce a mixture with moisture content of 42%?
- 5.548 Compost is blended from bulking material and dewatered sludge. The bulking material is to be mixed with 7.4 yd³ of dewatered sludge at a ratio (by volume) of 3:1. The solids content of the sludge is 19% and the solids content of the bulking material is 54%. If the bulk density of the sludge is 1710 lb/yd³ and the bulk density of the bulking material is 760 lb/yd³, what is the percent solids of the compost blend?

- 5.549 A composting facility has an available capacity of 8200 yd³. If the composting cycle is 21 days, how many pounds per day wet compost can be processed by this facility? Assume a compost bulk density of 1100 lb/yd³.
- 5.550 Compost is to be blended from wood chips and dewatered sludge. The wood chips are to be mixed with 12 yd³ of dewatered sludge at a ratio (by volume) of 3:1. The solids content of the sludge is 16% and the solids content of the wood chips is 55%. If the bulk density of the sludge is 1720 lb/yd³ and the bulk density of the wood chips is 820 lb/yd³, what is the percent solids of the compost blend?
- 5.551. Given the data listed below, calculate the solids processing capability of the compost operation in pounds per day.
- Cycle time = 21 days
- Total available capacity = 7810 yd³
- % Solids of wet sludge = 19%
- Mix ratio (by volume) of wood chips to sludge = 3:1
- Wet compost bulk density = 1100 lb/yd³
- Wet sludge bulk density = 1720 lb/yd³
- Wet wood chips bulk density = 780 lb/yd³

5.11.6 General Sludge Dewatering Calculations

- 5.552 Sludge is applied to a drying bed 220 ft long by 24 ft wide. The sludge has a total solids concentration of 3.3% and fills the bed to a depth of 10 in. It takes an average of 22 days for the sludge to dry and 1 day to remove the dried solids. How many pounds of solids can be dried for every square foot of drying bed area each year?
- 5.553 A belt filter press receives a daily sludge flow of 0.20 million gallons. If the belt is 70 in. wide, what is the hydraulic loading rate on the unit in gallons per minute for each foot of belt width (gpm/ft)?
- 5.554 A plate-and-frame filter press can process 960 gal of sludge during its 140-minute operating cycle. If the sludge concentration is 4.2%, and if the plate surface area is 150 ft², how many pounds of solids are pressed per hour for each square foot of plate surface area?
- 5.555 Thickened thermally conditioned sludge is pumped to a vacuum filter at a rate of 36 gpm. The vacuum area of the filter is 10 ft wide with a drum diameter of 9.6 ft. If the sludge concentration is 12%, what is the filter yield in pounds per hour per square foot? Assume that the sludge weighs 8.34 lb/gal.
- 5.556 The vacuum filter produces an average of 3020 lb of sludge cake each hour. The total solids content of the cake produced is 40%. The sludge is being pumped to the filter at a rate of 24 gpm and at a concentration of 11%. If the sludge density is 8.50 lb/gal, what is the percent recovery of the filter?

- 5.557 The amount of sludge to be dewatered by the belt press is 25,200 lb/day. If the belt filter press is to be operated 12 hr each day, what should the sludge feed rate to the press be in pounds per hour?
- 5.558 A filter press used to dewater digested primary sludge receives a flow of 800 gal of sludge during a 2-hr period. The sludge has a solids content of 4.1%. If the plate surface area is 141 ft², what is the solids loading rate in pounds per hour per square foot? Assume that the sludge weighs 8.34 lb/gal.
- 5.559 The sludge feed rate to belt filter press is 170 gpm. The total suspended solids concentration of the feed is 5%. The flocculation used for sludge conditioning is a 0.9% concentration, with a feed rate of 2.8 gpm. What is the flocculant dose expected as pound flocculant per ton of solids treated?
- 5.560 A plate-and-frame filter press receives solids loading of 0.8 lb/hr/ft². If the filtration time is 2 hr and the time required to remove the sludge cake and begin sludge feed to the press is 20 minutes, what is the net filter yield in pounds per hour per square foot? Assume that the sludge weighs 8.34 lb/gal.
- 5.561 Laboratory tests indicate that the total residue portion of a feed sludge sample is 24,300 mg/L. The total filterable residue is 740 mg/L. On this basis what is the estimated total suspended solids concentration of the sludge sample?
- 5.562 Digested sludge is applied to a vacuum filter at a rate of 80 gpm with a solids concentration of 5.5%. If the vacuum filter has a surface area of 320 ft², what is the filter loading in pounds per hour per square foot? Assume that the sludge weighs 8.34 lb/gal.
- 5.563 The wet cake flow from a vacuum filter is 7500 lb/hr. If the filter area is 320 ft² and the percent solids in the cake is 26%, what is the filter yield in pounds per hour per square foot?
- 5.564 A belt filter should dewater 28,300 lb of sludge per day. If the maximum feed rate that still provides an acceptable cake is 1800 lb/hr, how many hours per day should the belt remain in operation?
- 5.565 A total of 5700 lb/day primary sludge solids is to be processed by a vacuum filter. The vacuum filter yield is 3.1 lb/hr/ft². The solids recovery is 92%. If the area of the filter is 280 ft², how many hours per day must the vacuum filter remain in operation to process this much solids?
- 5.566 Sludge is applied to a drying bed 220 ft long by 30 ft wide to a depth of 9 in. How many gallons of sludge are applied to the drying bed?
- 5.567 The sludge feed to a vacuum filter is 91,000 lb/day, with a solids content of 5.3%. If the wet cake flow is 14,300 lb/day with 28% solids content, what is the percent solids recovery?
- 5.568 A sludge drying bed is 200 ft long by 25 ft wide. The sludge is applied to a depth of 8 in. The solids concentration of the sludge is 5.1%. If the drying and removal cycle requires 20 days, what is the solids loading rate to the beds in pounds per year per square foot? Assume that the sludge weighs 8.34 lb/gal.

- 5.569 A drying bed is 190 ft long by 30 ft wide. If a 40-ft-diameter digester has a drawdown of 1 ft, how many feet deep will the drying bed be as a result of the drawdown?
- 5.570 A treatment plant produces a total of 6800 lb/day of dewatered digested primary sludge. The dewatered sludge has a solids concentration of 25%. Final compost to be used in blending has a moisture content of 36%. How much compost in pounds per day must be blended with the dewatered sludge to produce a mixture with a moisture content of 55%?
- 5.571 Compost is to be blended from wood chips and dewatered sludge. The wood chips are to be mixed with 7.0 yd³ of dewatered sludge at a ratio of 3:1. The solids content of the sludge is 16%, and the solids content of the wood chips is 51%. If the bulk density of the sludge is 1710 lb/yd³ and the bulk density of the wood chips is 780 lb/yd³, what is the percent solids of the compost blend?
- 5.572 A composting facility has an available capacity of 6350 yd³. If the composting cycle is 26 days, how many pounds per day wet compost can be processed by this facility? How many tons per day is this? Assume a compost bulk density of 980 lb/yd³.
- 5.573 Given the data listed below, calculate the dry sludge processing capability of the compost operation in pounds per day.

Cycle time = 24 days

Total available capacity = 9000 yd³

% Solids of wet sludge = 18%

Mix ratio (by volume) of wood chips to sludge = 3:1

Wet compost bulk density = 1100 lb/yd³

Wet sludge bulk density = 1710 lb/yd³

Wet wood chips bulk density = 800 lb/yd³

REFERENCES AND RECOMMENDED READING

Spellman, F.R. (2009). *Handbook of Water and Wastewater Treatment Plant Operations*, 2nd ed. Boca Raton, FL: CRC Press.

COMPREHENSIVE PRACTICE EXAM

6.1 INTRODUCTION

The following comprehensive examination is provided to test your overall knowledge of the material contained in all three volumes of this handbook. If you have difficulty answering some of the questions or you answer some incorrectly (see Appendix A for the answers and solutions), review the sections containing the pertinent subject matter. Thorough study of all of the material presented throughout this handbook series should prepare you for the certification or licensure examination at the highest level.

Unlike the actual state licensure examinations, which contain an assortment of different types of questions (e.g., multiple choice, true or false, essay, completion questions), the final review exam presented here requires a written response to each question. The questions have been formatted in this way because experience has shown that, when studying for an exam (any exam), it is always best to write out the answer for better retention. Moreover, when studying for an exam, it is best to consider only the correct answer instead of several different choices (e.g., multiple choice questions) that could possibly be the correct answer, which can lead to the test taker selecting the wrong answer on the licensure exam.

Good luck!

6.2 COMPREHENSIVE PRACTICE EXAM

- 6.1 Who must sign the DMR?
- 6.2 What does the COD test measure?
- 6.3 Give three reasons for treating wastewater.
- 6.4 Name two types of solids based on physical characteristics.
- 6.5 Define *organic* and *inorganic*.
- 6.6 Name four types of microorganisms that may be present in wastewater.
- 6.7 When organic matter is decomposed aerobically, what materials are produced?
- 6.8 Name three materials or pollutants that are not removed by the natural purification process.
- 6.9 What do we call the used water and solids from a community that flow to a treatment plant?
- 6.10 Where do disease-causing bacteria in wastewater come from?
- 6.11 What does the term *pathogenic* mean?
- 6.12 What is wastewater called that comes from households?
- 6.13 What is wastewater from industrial complexes called?
- 6.14 The lab test indicates that a 500-g sample of sludge contains 22 g of solids. What is the percent solids in the sludge sample?
- 6.15 The depth of water in the grit channel is 28 in. What is the depth in feet?
- 6.16 The operator withdraws 5250 gal of solids from the digester. How many pounds of solids have been removed?
- 6.17 Sludge added to the digester causes a 1920 ft³ change in the volume of sludge in the digester. How many gallons of sludge have been added?
- 6.18 The plant effluent contains 30 mg/L solids. The effluent flow rate is 3.40 MGD. How many pounds per day of solids are discharged?
- 6.19 The plant effluent contains 25 mg/L BOD₅. The effluent flow rate is 7.25 MGD. How many kilograms per day of BOD₅ are being discharged?
- 6.20 The operator wishes to remove 3280 lb/day of solids from the activated sludge process. The waste activated sludge concentration is 3250 mg/L. What is the required flow rate in million gallons per day?
- 6.21 The plant influent includes an industrial flow that contains 240 mg/L BOD. The industrial flow is 0.72 MGD. What is the population equivalent for the industrial contribution in people per day?

- 6.22 The label of hypochlorite solution states that the specific gravity of the solution is 1.1288. What is the weight of 1 gallon of the hypochlorite solution?
- 6.23 What must be done to the cutters in a comminutor to ensure proper operation?
- 6.24 What is grit? Give three examples of material that is considered to be grit.
- 6.25 The plant has three channels in service. Each channel is 2 ft wide and has a water depth of 3 ft. What is the velocity in the channel when the flow rate is 8.0 MGD?
- 6.26 The grit from the aerated grit channel has a strong hydrogen sulfide odor upon standing in a storage container. What does this indicate and what action should be taken to correct the problem?
- 6.27 What is the purpose of primary treatment?
- 6.28 What is the purpose of the settling tank in the secondary or biological treatment process?
- 6.29 The circular settling tank is 90 ft in diameter and has a depth of 12 ft. The effluent weir extends around the circumference of the tank. The flow rate is 2.25 MGD. What is the detention time in hours, surface loading rate in gallons per day per square foot, and weir overflow rate in gallons per day per foot?
- 6.30. Give three classifications of ponds based on their location in the treatment system.
- 6.31. Describe the processes occurring in a raw sewage stabilization pond (facultative).
- 6.32. How do changes in the season affect the quality of the discharge from a stabilization pond?
- 6.33 What is the advantage of using mechanical or diffused aeration equipment to provide oxygen?
- 6.34 Name three classifications of trickling filters and identify the classification that produces the highest quality effluent.
- 6.35 Microscopic examination reveals a predominance of rotifers. What process adjustment does this indicate is required?
- 6.36 Increasing the wasting rate will _____ the MLSS, _____ the return concentration, _____ the MCRT, _____ the F/M ratio, and _____ the SVI.
- 6.37 The plant currently uses 45.8 lb of chlorine per day. Assuming the chlorine usage will increase by 10% during the next year, how many 2000-lb cylinders of chlorine will be needed for the year (365 days)?
- 6.38 The plant has six 2000-lb cylinders on hand. The current dose of chlorine being used to disinfect the effluent is 6.2 mg/L. The average effluent flow rate is 2.25 MGD. Allowing 15 days for ordering and shipment, when should the next order for chlorine be made?

- 6.39 The plant feeds 38 lb of chlorine per day and uses 150-lb cylinders. Chlorine use is expected to increase by 11% next year. The chlorine supplier has stated that the current price of chlorine (\$0.170 per pound) will increase by 7.5% next year. How much money should the town budget for chlorine purchases for the next year (365 days)?
- 6.40 The sludge pump operates 30 minutes every 3 hours. The pump delivers 70 gpm. If the sludge is 5.1% solids and has a volatile matter content of 66%, how many pounds of volatile solids are removed from the settling tank each day?
- 6.41 The aerobic digester has a volume of 63,000 gal. The laboratory test indicates that 41 mg of lime were required to increase the pH of a 1-L sample of digesting sludge from 6.0 to the desired 7.1. How many pounds of lime must be added to the digester to increase the pH of the unit to 7.4?
- 6.42 The digester has a volume of 73,500 gal. Sludge is added to the digester at the rate of 2750 gal per day. What is the sludge retention time in days?
- 6.43 The raw sludge pumped to the digester contains 72% volatile matter. The digested sludge removed from the digester contains 48% volatile matter. What is the percent volatile matter reduction?
- 6.44 What does NPDES stand for?
- 6.45 How can primary sludge be freshened going into a gravity thickener?
- 6.46 A neutral solution has what pH value?
- 6.47 Why is the seeded BOD test required for some samples?
- 6.48 What is the foremost advantage of the COD over the BOD?
- 6.49 High mixed liquor concentration is indicated by a _____ aeration tank foam.
- 6.50 What typically happens to the activity level of bacteria when the temperature is increased?
- 6.51 List three factors other than food that affect the growth characteristics of activated sludge.
- 6.52 What are the characteristics of facultative organisms?
- 6.53 BOD measures the amount of _____ material in wastewater.
- 6.54 The activated sludge process requires _____ in the aeration tank to be successful.
- 6.55 The activated sludge process cannot be successfully operated with a _____ clarifier.
- 6.56 The activated biosolids process can successfully remove _____ BOD.
- 6.57 Successful operation of a complete mix reactor in the endogenous growth phase is _____.

- 6.58 The bacteria in the activated biosolids process are either _____ or _____.
- 6.59 Step feed activated biosolids processes have _____ mixed liquor concentrations in different parts of the tank.
- 6.60 An advantage of contact stabilization compared to complete mix is _____ aeration tank volume.
- 6.61 Increasing the _____ of wastewater increases the BOD in the activated biosolids process.
- 6.62 Bacteria require phosphorus to successfully remove _____ in the activated biosolids process.
- 6.63 What controls the growth rate of microorganisms?
- 6.64 Adding chlorine just before the _____ can control alga growth.
- 6.65 What is the purpose of the secondary clarifier in an activated biosolids process?
- 6.66 The _____ growth phase should occur in a complete mix activated biosolids process.
- 6.67 The typical DO value for activated biosolids plants is between _____ and _____ mg/L.
- 6.68 In the activated biosolids process, what change would an operator normally make when the temperature drops from 25°C to 15°C?
- 6.69 In the activated biosolids process, what change must be made to increase the MLVSS?
- 6.70 In the activated biosolids process, what change must be made to increase the F/M?
- 6.71 What does the Gould sludge age assume to be the source of the MLVSS in the aeration tank?
- 6.72 What is one advantage of complete mix over plug flow?
- 6.73 The grit in the primary sludge is causing excessive wear on primary treatment sludge pumps. The plant uses an aerated grit channel. What action should be taken to correct this problem?
- 6.74 When the mean cell residence time (MCRT) increases, what happens to the mixed liquor suspended solids (MLSS) concentration in the aeration tank?
- 6.75 Exhaust air from a chlorine room should be taken from where?
- 6.76 If chlorine costs \$0.21/lb, what is the daily cost to chlorinate a 5-mgd flow rate at chlorine feed rate of 2.6 mg/L?
- 6.77 What is the term that describes a normally aerobic system from which the oxygen has temporarily been depleted?
- 6.78 The ratio that describes the minimum amount of nutrients theoretically required for an activated sludge system is 100:5:1. What are the elements that fit this ratio?
- 6.79 A flotation thickener is best used for what type of sludge?

- 6.80 Drying beds are/are not (circle correct choice) an example of a sludge stabilization process?
- 6.81 The minimum flow velocity in collection systems should be _____.
- 6.82 What effect will the addition of chlorine, acid, alum, carbon dioxide, or sulfuric acid have on the pH of wastewater?
- 6.83 What does an amperometric titrator measure?
- 6.84 What is the normal design detention time for primary clarifier?
- 6.85 The volatile acids/alkalinity ratio in an anaerobic digester should be approximately _____.
- 6.86 The surface loading rate in a final clarifier should be approximately _____.
- 6.87 In a conventional effluent chlorination system the chlorine residual measured is mostly in the form of _____.
- 6.88 For a conventional activated biosolids process, the food-to-microorganism (F/M) ratio should be in the range of _____.
- 6.89 Denitrification in a final clarifier can cause clumps of sludge to rise to the surface. The sludge flocs attach to small sticky bubbles of _____ gas.
- 6.90 An anaerobic digester is covered and kept under positive pressure to _____.
- 6.91 During the summer months, the major source of oxygen added to a stabilization pond is _____.
- 6.92 Which solids cannot be removed by vacuum filtration?
- 6.93 The odor recognition threshold for H₂S is reported to be as low as _____.
- 6.94 A pump will pump a well 10 ft × 10 ft × 8 ft dry in 7 minutes. What is the pump output in gallons per minute?
- 6.95 The grit in primary sludge is causing excessive wear on primary treatment sludge pumps. The plant uses an aerated grit channel. What action should be taken to correct this problem?

REFERENCES AND RECOMMENDED READING

Metcalf & Eddy. (1991). *Wastewater Engineering: Treatment, Disposal, Reuse*, 3rd ed. New York: McGraw-Hill.

Metcalf & Eddy. (2003). *Wastewater Engineering: Treatment, Disposal, Reuse*, 4th ed. New York: McGraw-Hill.

Spellman, F.R. (2007). *The Science of Water*, 2nd ed. Boca Raton, FL: CRC Press.

USEPA. (2007). *Advanced Wastewater Treatment to Achieve Low Concentration of Phosphorus*. Washington, D.C.: U.S. Environmental Protection Agency.

ANSWERS TO CHAPTER REVIEW QUESTIONS

CHAPTER 1 ANSWERS

- 1.1 Ecosystem
- 1.2 Benthos
- 1.3 Periphyton
- 1.4 Plankton
- 1.5 Pelagic
- 1.6 Neuston
- 1.7 Immigration
- 1.8 Autotrophs
- 1.9 Lentic
- 1.10 Dissolved oxygen solubility

CHAPTER 2 ANSWERS

- 2.1 Na
- 2.2 H_2SO_4
- 2.3 7
- 2.4 Base
- 2.5 Changes

- 2.6 Solid, liquid, gas
- 2.7 Element
- 2.8 Compound
- 2.9 Periodic
- 2.10 Solvent, solute
- 2.11 An atom or group of atoms that carries a positive or negative electrical charge as a result of having lost or gained one or more electrons
- 2.12 Colloid
- 2.13 Turbidity
- 2.14 Result of dissolved chemicals
- 2.15 Toxicity
- 2.16 Organic
- 2.17 0; 14
- 2.18 Ability of water to neutralize an acid
- 2.19 Calcium and magnesium
- 2.20 Base

CHAPTER 3 ANSWERS

- 3.1 Screwed joint
- 3.2 Welded joint
- 3.3 Soldered joint
- 3.4 Screwed glove valve
- 3.5 Globe valve
- 3.6 Screwed check valve
- 3.7 Pump
- 3.8 Flexible line
- 3.9 Check valve
- 3.10 Heat exchanger
- 3.11 Expansion joint
- 3.12 Vibration absorber
- 3.13 Battery cell
- 3.14 Motor
- 3.15 Relay
- 3.16 Voltmeter

- 3.17 Ammeter
- 3.18 Knife switch
- 3.19 Fuse
- 3.20 Transformer
- 3.21 Ground
- 3.22 Normally open contacts
- 3.23 Local note reference
- 3.24 Fillet weld
- 3.25 Square butt weld
- 3.26 Single hem
- 3.27 Single flange
- 3.28 Location of weld
- 3.29 Steel section
- 3.30 Bevel weld
- 3.31 V weld
- 3.32 J-groove weld
- 3.33 4 times true size
- 3.34 Drawing number
- 3.35 180
- 3.36 Break line
- 3.37 Object line
- 3.38 3D pictorial
- 3.39 Shape; complexity
- 3.40 Limits
- 3.41 Center line; finished surface
- 3.42 Volute
- 3.43 Hem
- 3.44 Seam
- 3.45 Relief valve
- 3.46 Gas; liquid
- 3.47 Butt
- 3.48 Architectural
- 3.49 Plot plan
- 3.50 Line

CHAPTER 5 ANSWERS

- 5.1 $4.9 \text{ MGD} \times (1 \text{ day}/24 \text{ hr}) \times 96 \text{ hr} = 19.6 \text{ MG}$
 $\frac{4.3 \text{ ft} \times 5.8 \text{ ft} \times 28 \text{ in.}}{19.6 \text{ MG}} \times \frac{1 \text{ ft}}{12 \text{ in.}} = 3.0 \text{ ft}^3/\text{MG}$
- 5.2 $\frac{700 \text{ gpm}}{7.48 \text{ gal}/\text{ft}^3} = 93.6 \text{ ft}^3/\text{min}$
 $\frac{93.6 \text{ ft}^3}{1 \text{ min}} \times \frac{1 \text{ min}}{60 \text{ s}} \times \frac{1}{1.4 \text{ ft} \times 1.7 \text{ ft}} = 0.7 \text{ ft/s}$
- 5.3 $\frac{1,200,000 \text{ gal}}{1 \text{ day}} \times \frac{1 \text{ day}}{24 \text{ hr}} \times \frac{1 \text{ hr}}{60 \text{ min}} = \frac{1,200,000 \text{ gal}}{1440 \text{ min/day}} = 833 \text{ gpm}$
 $\frac{16 \text{ in.}}{12 \text{ in.}} = 1.4 \text{ ft}; \quad \frac{18 \text{ in.}}{12 \text{ in.}} = 1.6 \text{ ft}$
 $\frac{883 \text{ gal}}{1 \text{ min}} \times \frac{1 \text{ ft}^3}{7.48 \text{ gal}} \times \frac{1 \text{ min}}{60 \text{ s}} = 1.97 \text{ ft}^3/\text{s}$
 $\frac{1.97 \text{ ft}^3}{1 \text{ s}} \times \frac{1}{1.33 \text{ ft} \times 1.5 \text{ ft}} = 0.99 \text{ ft/s}$
- 5.4 $12 \text{ ft} \times 10 \text{ ft} \times 6 \text{ ft} \times 7.48 \text{ gal}/\text{ft}^3 = 5386 \text{ gal}$
- 5.5 $14 \text{ ft} \times 12 \text{ ft} \times 6 \text{ ft} \times 7.48 \text{ gal}/\text{ft}^3 = 7540 \text{ gal}$
- 5.6 $9 \text{ ft} \times 9 \text{ ft} \times 6 \text{ ft} = 486 \text{ ft}^3$
- 5.7 $12 \text{ ft} \times 8 \text{ ft} \times x \text{ ft} \times 7.48 \text{ gal}/\text{ft}^3 = 4850 \text{ gal}, \quad x = 6.8 \text{ ft}$
- 5.8 $10 \text{ ft} \times 8 \text{ ft} \times 3.1 \text{ ft} \times 7.48 \text{ gal}/\text{ft}^3 = 1855 \text{ gal}$
- 5.9 $\frac{10 \text{ ft} \times 10 \text{ ft} \times 1.8 \text{ ft} \times 7.48 \text{ gal}/\text{ft}^3}{5 \text{ min}} = 269 \text{ gpm}$
- 5.10 $\frac{12 \text{ ft} \times 12 \text{ ft} \times 1.3 \text{ ft} \times 7.48 \text{ gal}/\text{ft}^3}{3 \text{ min}} = 467 \text{ gpm}$
- 5.11 $\frac{9 \text{ ft} \times 7 \text{ ft} \times 1.4 \text{ ft} \times 7.48 \text{ gal}/\text{ft}^3}{3 \text{ min}} = 220 \text{ gpm}$
- 5.12 $\frac{9 \text{ ft} \times 8 \text{ ft} \times 0.9 \text{ ft} \times 7.48 \text{ gal}/\text{ft}^3}{1 \text{ min}} = 485 \text{ gpm}$

5.13 $12 \text{ ft} \times 14 \text{ ft} \times -2.2 \text{ ft} \times 7.48 \text{ gal/ft}^3 = -2765 \text{ gal}$

$$\frac{-2765 \text{ gal}}{5 \text{ min}} = -553 \text{ gpm}$$

$$0 \text{ gpm} = \text{Discharge} + (-553 \text{ gpm})$$

$$533 \text{ gpm} = \text{Discharge}$$

5.14 $\text{Accumulation} = \frac{12 \text{ ft} \times 14 \text{ ft} \times -1.9 \text{ ft} \times 7.48 \text{ gal/ft}^3}{4 \text{ min}} \times -597 \text{ gpm}$

$$0 \text{ gpm} = \text{Discharge} + (-597 \text{ gpm})$$

$$597 \text{ gpm} = \text{Discharge}$$

5.15 $10 \text{ ft}, 9 \text{ in.} = 10.75 \text{ ft}$

$$12 \text{ ft}, 2 \text{ in.} = 12.17 \text{ ft}$$

$$\text{Accumulation} = \frac{10.75 \text{ ft} \times 12.12 \text{ ft} \times -2 \text{ ft} \times 7.48 \text{ gal/ft}^3}{5.5 \text{ min}} = -354 \text{ gpm}$$

$$0 \text{ gpm} = \text{Discharge} + (-354 \text{ gpm})$$

$$354 \text{ gpm} = \text{Discharge}$$

5.16 $410 \text{ gpm} = \text{Discharge} + \text{Accumulation}$

$$\text{Accumulation} = \frac{11.8 \text{ ft} \times 14 \text{ ft} \times 0.083 \text{ ft} \times 7.48 \text{ gal/ft}^3}{7} = 14.5 \text{ gpm}$$

$$410 \text{ gpm} = \text{Discharge} + 14.5 \text{ gpm}$$

$$395.5 \text{ gpm} = \text{Discharge}$$

5.17 $140 \text{ in.} = 11.7 \text{ ft}; 148 \text{ in.} = 12.3 \text{ ft}$

$$\text{Accumulation} = \frac{11.7 \text{ ft} \times 12.3 \text{ ft} \times -0.125 \text{ ft} \times 7.48 \text{ gal/ft}^3}{6 \text{ min}} = -22.4 \text{ gpm}$$

$$430 \text{ gpm} = \text{Discharge} + (-22.4 \text{ gpm})$$

$$452.4 \text{ gpm} = \text{Discharge}$$

5.18 $\text{Accumulation} = \frac{9.8 \text{ ft} \times 14 \text{ ft} \times -0.7 \text{ ft} \times 7.48 \text{ gal/ft}^3}{15 \text{ min}} = -48 \text{ gpm}$

$$800 \text{ gpm} = \text{Discharge} + (-48 \text{ gpm})$$

$$848 \text{ gpm} = \text{Discharge}$$

$$848 \text{ gpm} = 500 \text{ gpm} + \text{Second Pump Discharge}$$

$$348 \text{ gpm} = \text{Second Pump Discharge}$$

$$5.19 \quad \frac{60 \text{ gpd}}{7.48 \text{ gal/ft}^3} = 8 \text{ ft}^3/\text{day}$$

$$5.20 \quad \frac{282 \text{ gal/wk}}{7.48 \text{ gal/ft}^3 \times 7 \text{ days/wk}} = 5.4 \text{ ft}^3/\text{day}$$

$$5.21 \quad \frac{4.9 \text{ ft}^3}{3.33 \text{ MGD}} = 1.5 \text{ ft}^3/\text{MG}$$

$$5.22 \quad \frac{\frac{81 \text{ gal/day}}{7.48 \text{ gal/ft}^3}}{4.9 \text{ MGD}} = 2.2 \text{ ft}^3/\text{MG}$$

$$5.23 \quad \frac{\frac{48 \text{ gal/day}}{7.48 \text{ gal/ft}^3}}{2.28 \text{ MGD}} = 2.8 \text{ ft}^3/\text{MG}$$

$$5.24 \quad \frac{600 \text{ ft}^3}{2.9 \text{ ft}^3/\text{day}} = 207 \text{ days}$$

$$5.25 \quad \frac{9 \text{ yd}^3 \times 27 \text{ ft}^3/\text{yd}^3}{1.6 \text{ ft}^3/\text{day}} = 152 \text{ days}$$

$$5.26 \quad 2.6 \text{ ft}^3/\text{MG} \times 2.9 \text{ MGD} = 7.5 \text{ ft}^3/\text{day}$$

$$\frac{292 \text{ ft}^3}{7.5 \text{ ft}^3/\text{day}} = 39 \text{ days}$$

$$5.27 \quad \frac{x \text{ ft}^3}{3.5 \text{ ft}^3/\text{day}} = 120 \text{ days}$$

$$x = 420 \text{ ft}^3$$

$$5.28 \quad 4 \text{ ft} \times 1.6 \text{ ft} \times x \text{ fps} = \frac{1820 \text{ gpm}}{7.48 \text{ gal/ft}^3 \times 60 \text{ s/min}}$$

$$x = 0.6 \text{ fps}$$

$$5.29 \quad 26 \text{ ft} \div 32 \text{ s} = 0.8 \text{ fps}$$

$$5.30 \quad 3 \text{ ft} \times 1.2 \text{ ft} \times x \text{ fps} = 4.3 \text{ cfs}, \quad x = 1.2 \text{ fps}$$

$$5.31 \quad 36 \text{ ft}/32 \text{ s} = 1.2 \text{ fps}$$

$$5.32 \quad 2.8 \text{ ft} \times 1.3 \text{ ft} \times x \text{ fps} = \frac{1140 \text{ gpm}}{7.48 \text{ gal/ft}^3 \times 60 \text{ s/min}}, \quad x = 0.7 \text{ fps}$$

- 5.33 $\frac{12 \text{ ft}^3/\text{day}}{8 \text{ MGD}} = 1.5 \text{ ft}^3/\text{MG}$
- 5.34 $\frac{260 \text{ gal/day}}{7.48 \text{ gal/ft}^3 \times 11.4 \text{ MGD}} = 3 \text{ ft}^3/\text{MG}$
- 5.35 $3.1 \text{ ft}^3/\text{MG} \times 3.8 \text{ MGD} = 11.8 \text{ ft}^3/\text{day}$
 $11.8 \text{ ft}^3/\text{day} \times 30 \text{ days/month} = 354 \text{ ft}^3/\text{month}$
 $\frac{354 \text{ ft}^3/\text{month}}{27 \text{ ft}^3/\text{yd}^3} = 13.1 \text{ yd}^3/\text{month}$
- 5.36 $2.2 \text{ ft}^3/\text{MG} \times 4.23 \text{ MGD} \times 90 \text{ days} = 838 \text{ ft}^3 \text{ required}$
 $\frac{838 \text{ ft}^3}{27 \text{ ft}^3/\text{yd}^3} = 31 \text{ yd}^3$
- 5.37 $2.6 \text{ ft} \times 1.3 \text{ ft} \times 1.1 \text{ fps} = 3.7 \text{ cfs}$
- 5.38 $3 \text{ ft} \times 1.2 \text{ ft} \times 1.4 \text{ fps} \times 7.48 \text{ gal/ft}^3 \times 60 \text{ s/min} \times 1440 \text{ min/day}$
 $= 3,257,211 \text{ gpd}$
- 5.39 $2.7 \text{ ft} \times 0.83 \text{ ft} \times 0.90 \text{ fps} = 2 \text{ cfs}$
- 5.40 $25.6782 \text{ g} - 25.6662 \text{ g} = .0120 \text{ g}$
 $0.0120 \text{ g} \times 1000 \text{ mg/L} = 12 \text{ mg}/0.05 \text{ L} = 240 \text{ mg/L}$
- 5.41 $26.2410 \text{ g} - 26.2345 \text{ g} = 0.0065 \text{ g}$
 $0.0065 \text{ g} \times 1000 \text{ mg} = 6.5 \text{ mg}$
 $6.5 \text{ mg} \div 0.026 \text{ L} = 250 \text{ mg/L}$
- 5.42 $8.42 \text{ mg/L} - 4.28 \text{ mg/L} = 4.14 \text{ mg/L}$
 $6 \text{ mL} \div 300 \text{ mL} = 0.02$
 $4.14 \text{ mg/L} \div 0.02 = 207 \text{ mg/L}$
- 5.43 $\text{BOD} = (7.96 \text{ mg/L} - 4.26 \text{ mg/L}) \times (300 \text{ mL}/5 \text{ mL}) = 222 \text{ mg/L}$
- 5.44 $14.6 \text{ mg/L} \times 3.13 \text{ MGD} \times 8.34 \text{ lb/gal} = 381 \text{ lb/day}$
- 5.45 $310 \text{ mg/L} \times 6.15 \text{ MGD} \times 8.34 \text{ lb/gal} = 15,900 \text{ lb/day}$
- 5.46 $188 \text{ mg/L} \times 4.85 \text{ MGD} \times 8.34 \text{ lb/gal} = 7604 \text{ lb/day}$
- 5.47 $\frac{270 \text{ ft}^3}{2.6 \text{ ft}^3/\text{MG} \times 2.95 \text{ MGD}} = 35 \text{ days}$

- 5.48 $\frac{210 \text{ gal}}{7.48 \text{ gal/ft}^3 \times 7 \text{ days}} = 4 \text{ ft}^3/\text{day}$
- 5.49 $\frac{5.4 \text{ ft}^3}{2.91 \text{ MGD}} = 1.85 \text{ ft}^3/\text{MG}$
- 5.50 $\frac{12 \text{ yd}^3 \times 27 \text{ ft}^3/\text{yd}^3}{2.4 \text{ ft}^3/\text{day}} = 135 \text{ days}$
- 5.51 $\frac{36 \text{ ft}}{30 \text{ s}} = 1.2 \text{ fps}$
- 5.52 $2.6 \text{ ft} \times 1.3 \text{ ft} \times 0.8 \text{ fps} = 2.7 \text{ cfs}$
- 5.53 $\frac{210 \text{ gal}}{7.48 \text{ gal/ft}^3 \times 8.8 \text{ MGD}} = 3.2 \text{ ft}^3/\text{MG}$
- 5.54 $2.6 \text{ ft} \times 1.3 \text{ ft} \times 1.8 \text{ fps} \times 7.48 \text{ gal/ft}^3 \times 60 \text{ s/min} = 2730 \text{ gal}$
- 5.55 $2.3 \text{ ft}^3/\text{MG} \times (3.61 \text{ MGD} \times 30 \text{ days}) = 249 \text{ ft}^3$
 $249 \text{ ft}^3 \div 27 \text{ ft}^3/\text{yd}^3 = 9.2 \text{ yd}^3$
- 5.56 $3 \text{ ft} \times 0.83 \text{ ft} \times 1 \text{ fps} = 2.5 \text{ cfs}$
- 5.57 $160,000 \text{ gal} \div 75,417 \text{ gal/hr} = 2.1 \text{ hr}$
- 5.58 $\frac{90 \text{ ft} \times 25 \text{ ft} \times 10 \text{ ft} \times 7.48 \text{ gal/ft}^3}{135,416 \text{ gal/hr}} = 1.2 \text{ hr}$
- 5.59 $\frac{0.785 \times 90 \text{ ft} \times 90 \text{ ft} \times 12 \text{ ft} \times 7.48 \text{ gal/ft}^3}{181,250 \text{ gal/hr}} = \frac{570,739}{181,250 \text{ gal/hr}} = 3.1 \text{ hr}$
- 5.60 $84 \text{ ft} \times 20 \text{ ft} \times 13.1 \text{ ft} \times 7.48 \text{ gal/ft}^3 = 164,619 \text{ gal}$
 Detention Time = $164,619 \text{ gal} \times (1 \text{ day}/2,010,000 \text{ gal}) \times 24 \text{ hr/day}$
 $= 1.97 \text{ hr}$
- 5.61 $90 \text{ ft} \times 20 \text{ ft} = 1800 \text{ ft}^2$
 $1,450,000 \text{ gpd} \div 1800 \text{ ft}^2 = 806 \text{ gpd/ft}^2$
- 5.62 Sample Weight = $73.86 \text{ g} - 22.20 \text{ g} = 51.66 \text{ g}$
 Dry Solids Weight = $23.10 \text{ g} - 22.20 \text{ g} = 0.90 \text{ g}$
 $\frac{0.90 \text{ g}}{51.66 \text{ g}} \times 100\% = 1.7\%$

5.63 $390 \text{ gpm} \times 60 \text{ min/hr} \times 24 \text{ hr/day} \times 8.34 \text{ lb/gal} \times .8\% = 37,467 \text{ lb/day}$

5.64 $140 \text{ mg/L} - 50 \text{ mg/L} = 90 \text{ mg/L}$

$$\% \text{ Removal} = \frac{90 \text{ mg/L}}{140 \text{ mg/L}} \times 100 = 64.3\%$$

5.65 $\frac{1,420,000 \text{ gpd}}{80 \text{ ft}} = 17,750 \text{ gpd/ft}$

5.66 $80 \text{ ft} \times 20 \text{ ft} \times 12 \text{ ft} \times 7.48 \text{ gal/ft}^3 = 143,616 \text{ gal}$

$$\text{Detention Time} = (3 \text{ tanks} \times 143,616 \text{ gal}) \times \frac{1}{5,000,000 \text{ gpd}} \\ \times (24 \text{ hr/day} \times 60 \text{ min/hr}) = 124 \text{ min}$$

$$\text{Surface Overflow Rate} = \frac{5,000,000 \text{ gal}}{3 \times 80 \text{ ft} \times 20 \text{ ft}} = 1042 \text{ gpd/ft}^2$$

$$\text{Weir Overflow Rate} = \frac{5,000,000 \text{ gpd}}{3 \times 86 \text{ ft}} = 19,380 \text{ gpd/ft}$$

5.67 $\frac{80 \text{ ft} \times 35 \text{ ft} \times 12 \text{ ft} \times 7.48 \text{ gal/ft}^3}{135,000 \text{ gal/hr}} = 1.9 \text{ hr}$

5.68 $\frac{1,520,000 \text{ gpd}}{112 \text{ ft}} = 13,571 \text{ gpd/ft}$

5.69 $\frac{2,980,000 \text{ gpd}}{3.14 \times 70 \text{ ft}} = 13,558 \text{ gpd/ft}$

5.70 $\frac{2520 \text{ gpm} \times 1440 \text{ min/day}}{3.14 \times 90 \text{ ft}} = 12,841 \text{ gpd/ft}$

5.71 $\frac{1,880,000 \text{ gpd}}{192 \text{ ft}} = 9792 \text{ gpd/ft}$

5.72 $\frac{2,910,000 \text{ gpd}}{0.785 \times 70 \text{ ft} \times 70 \text{ ft}} = 757 \text{ gpd/ft}^2$

5.73 $\frac{2,350,000 \text{ gpd}}{80 \text{ ft} \times 30 \text{ ft}} = 979 \text{ gpd/ft}^2$

5.74 $\frac{2,620,000 \text{ gpd}}{80 \text{ ft} \times 30 \text{ ft}} = 1092 \text{ gpd/ft}^2$

5.75 $\frac{2610 \text{ gpm} \times 1440 \text{ min/day}}{0.785 \times 60 \text{ ft} \times 60 \text{ ft}} = 1330 \text{ gpd/ft}^2$

$$5.76 \quad \frac{3110 \text{ mg/L} \times 4.1 \text{ MGD} \times 8.34 \text{ lb/gal}}{0.785 \times 70 \text{ ft} \times 70 \text{ ft}} = 27.6 \text{ lb/day/ft}^2$$

$$5.77 \quad \frac{3220 \text{ mg/L} \times 4.4 \text{ MGD} \times 8.34 \text{ lb/gal}}{0.785 \times 80 \text{ ft} \times 80 \text{ ft}} = 23.5 \text{ lb/day/ft}^2$$

$$5.78 \quad \frac{2710 \text{ mg/L} \times 3.22 \text{ MGD} \times 8.34 \text{ lb/gal}}{0.785 \times 70 \text{ ft} \times 70 \text{ ft}} = 18.9 \text{ lb/day/ft}^2$$

$$5.79 \quad \frac{3310 \text{ mg/L} \times 2.98 \text{ MGD} \times 8.34 \text{ lb/gal}}{0.785 \times 80 \text{ ft} \times 80 \text{ ft}} = 16.4 \text{ lb/day/ft}^2$$

$$5.80 \quad 125 \text{ mg/L} \times 5.55 \text{ MGD} \times 8.34 \text{ lb/gal} = 5786 \text{ lb/day}$$

$$5.81 \quad 40 \text{ mg/L} \times 2.92 \text{ MGD} \times 8.34 \text{ lb/gal} = 974 \text{ lb/day}$$

$$5.82 \quad 90 \text{ mg/L} \times 4.44 \text{ MGD} \times 8.34 \text{ lb/gal} = 3333 \text{ lb/day}$$

$$200 \text{ mg/L} \times 0.98 \text{ MGD} \times 8.34 \text{ lb/gal} = 1635 \text{ lb/day}$$

$$5.84 \quad \frac{135 \text{ mg/L}}{220 \text{ mg/L}} \times 100 = 61\%$$

$$5.85 \quad \frac{111 \text{ mg/L}}{188 \text{ mg/L}} \times 100 = 59\%$$

$$5.86 \quad \frac{220 \text{ mg/L}}{280 \text{ mg/L}} \times 100 = 79\%$$

$$5.87 \quad \frac{111 \text{ mg/L}}{300 \text{ mg/L}} \times 100 = 37\%$$

$$5.88 \quad \frac{0.785 \times 80 \text{ ft} \times 80 \text{ ft} \times 10 \text{ ft} \times 7.48 \text{ gal/ft}^3}{171,667 \text{ gal/hr}} = 2.2 \text{ hr}$$

$$5.89 \quad \frac{2,320,000 \text{ gpd}}{0.785 \times 60 \text{ ft} \times 60 \text{ ft}} = 821 \text{ gpd/ft}^2$$

$$5.90 \quad \frac{3,728,000 \text{ gpd}}{215 \text{ ft}} = 17,340 \text{ gpd/ft}^2$$

$$5.91 \quad \frac{2710 \text{ mg/L} \times 2.46 \text{ MGD} \times 8.34 \text{ lb/gal}}{0.785 \times 60 \text{ ft} \times 60 \text{ ft}} = 19.7 \text{ lb/day/ft}^2$$

$$5.92 \quad \frac{3,100,000 \text{ gpd}}{0.785 \times 70 \text{ ft} \times 70 \text{ ft}} = 806 \text{ gpd/ft}^2$$

- 5.93 $\frac{2910 \text{ mg/L} \times 3.96 \text{ MGD} \times 8.34 \text{ lb/gal}}{0.785 \times 80 \text{ ft} \times 80 \text{ ft}} = 19.1 \text{ lb/day/ft}^2$
 $118 \text{ mg/L} \times 5.3 \text{ MGD} \times 8.34 \text{ lb/gal} = 5216 \text{ lb/day}$
- 5.95 $\frac{90 \text{ ft} \times 40 \text{ ft} \times 14 \text{ ft} \times 7.48 \text{ gal/ft}^3}{212,500 \text{ gal/hr}} = 1.8 \text{ hr}$
- 5.96 $\frac{1940 \text{ gpm} \times 1440 \text{ min/day}}{3.14 \times 70 \text{ ft}} = 12,698 \text{ gpd/ft}$
- 5.97 $84 \text{ mg/L} \times 4.44 \text{ MGD} \times 8.34 \text{ lb/gal} = 3110 \text{ lb/day}$
- 5.98 $210 \text{ mg/L} \times 3.88 \text{ MGD} \times 8.34 \text{ lb/gal} = 6795 \text{ lb/day}$
- 5.99 $\frac{191 \text{ mg/L}}{260 \text{ mg/L}} \times 100 = 73\%$
- 5.100 $\frac{2,220,000 \text{ gpd}}{90 \text{ ft} \times 40 \text{ ft}} = 617 \text{ gpd/ft}^2$
- 5.101 $\frac{780,000 \text{ gpd}}{0.785 \times 80 \text{ ft} \times 80 \text{ ft}} = 155 \text{ gpd/ft}^2$
- 5.102 $\frac{2360 \text{ gpm} \times 1440 \text{ min/day}}{0.785 \times 90 \text{ ft} \times 90 \text{ ft}} = 534 \text{ gpd/ft}^2$
- 5.103 $\frac{1,500,000 \text{ gpd}}{0.785 \times 90 \text{ ft} \times 90 \text{ ft}} = 236 \text{ gpd/ft}^2$
- 5.104 $\frac{0.785 \times 96 \text{ ft} \times 96 \text{ ft}}{43,560 \text{ ft}^2/\text{ac}} = 0.17 \text{ ac}$
 $\frac{2.1 \text{ MGD}}{0.17 \text{ ac}} = 12.4 \text{ MGD/ac}$
- 5.105 $\frac{210 \text{ mg/L} \times 1.4 \text{ MGD} \times 8.34 \text{ lb/gal}}{47.1 \text{ ft}^3 \quad 1000 \text{ ft}^3} = 52 \text{ lb BOD/day/1000 ft}^3$
- 5.106 $\frac{111 \text{ mg/L} \times 3.40 \text{ MGD} \times 8.34 \text{ lb/gal}}{44.5 \text{ ft}^3 \quad 1000 \text{ ft}^3} = 70.7 \text{ lb BOD/day/1000 ft}^3$
- 5.107 $\frac{201 \text{ mg/L} \times 0.9 \text{ MGD} \times 8.34 \text{ lb/gal}}{35.1 \text{ ft}^3 \quad 1000 \text{ ft}^3} = 43 \text{ lb BOD/day/1000 ft}^3$

$$5.108 \quad \frac{0.785 \times 90 \text{ ft} \times 90 \text{ ft} \times 5 \text{ ft}}{43,560 \text{ ft}^3/\text{ac-ft}} = 0.73 \text{ ac-ft}$$

$$\frac{120 \text{ mg/L} \times 1.4 \text{ MGD} \times 8.34 \text{ lb/gal}}{0.73 \text{ ac-ft}} = 1919 \text{ lb BOD/day/ac-ft}$$

$$5.109 \quad 122 \text{ mg/L} \times 3.24 \text{ MGD} \times 8.34 \text{ lb/gal} = 3297 \text{ lb/day}$$

$$5.110 \quad 176 \text{ mg/L} \times 1.82 \text{ MGD} \times 8.34 \text{ lb/gal} = 2671 \text{ lb/day}$$

$$5.111 \quad 182 \text{ mg/L} \times 2.92 \text{ MGD} \times 8.34 \text{ lb/gal} = 4432 \text{ lb/day}$$

$$5.112 \quad 194 \text{ mg/L} \times 5.4 \text{ MGD} \times 8.34 \text{ lb/gal} = 8737 \text{ lb/day}$$

$$5.113 \quad \frac{101 \text{ mg/L}}{149 \text{ mg/L}} \times 100 = 68\%$$

$$5.114 \quad \frac{239 \text{ mg/L}}{261 \text{ mg/L}} \times 100 = 92\%$$

$$5.115 \quad \frac{179 \text{ mg/L}}{201 \text{ mg/L}} \times 100 = 89\%$$

$$5.116 \quad \frac{88 \text{ mg/L}}{111 \text{ mg/L}} \times 100 = 79\%$$

$$5.117 \quad 3.5 \text{ MGD} \div 3.4 \text{ MGD} = 1$$

$$5.118 \quad 2.32 \text{ MGD} \div 1.64 \text{ MGD} = 1.4$$

$$5.119 \quad 3.86 \text{ MGD} \div 2.71 \text{ MGD} = 1.4$$

$$5.120 \quad 1.6 = x \text{ MGD} \div 4.6 \text{ MGD} = 7.4 \text{ MGD}$$

$$5.121 \quad 0.310 \text{ MGD} + 0.355 \text{ MGD} = 0.655 \text{ MGD}$$

$$\text{Surface Area} = 0.785 \times 90 \text{ ft} \times 90 \text{ ft} = 6359 \text{ ft}^2$$

$$\frac{655,000 \text{ gpd}}{6359 \text{ ft}^2} = 103 \text{ gpd/ft}^2$$

$$5.122 \quad 4.55 \text{ MGD} \div 2.8 \text{ MGD} = 1.6$$

$$5.123 \quad 75 \text{ mg/L} \times 1.35 \text{ MGD} \times 8.34 \text{ lb/gal} = 844.4 \text{ lb/day}$$

$$\text{Surface Area} = 0.785 \times 80 \text{ ft}^2 \times 80 \text{ ft}^2 = 5024 \text{ ft}^2$$

$$5024 \text{ ft}^2 \times 6 \text{ ft} = 30,144 \text{ ft}^3$$

$$\frac{844.4 \text{ lb/day} \times 100 \text{ lb BOD}}{30,144 \text{ ft}^3 \quad 1000 \text{ ft}^3} = 28 \text{ lb/day/1000 ft}^3$$

- 5.124 $81 \text{ mg/L} - 13 \text{ mg/L} = 68 \text{ mg/L}$
 $68 \text{ mg/L} \times 4.1 \text{ MGD} \times 8.34 \text{ lb/gal} = 2325 \text{ lb/day}$
- 5.125 $\frac{630,000 \text{ gpd}}{0.785 \times 80 \text{ ft} \times 80 \text{ ft}} = 125 \text{ gpd/ft}^2$
- 5.126 $\frac{180 \text{ mg/L} \times 1.4 \text{ MGD} \times 8.34 \text{ lb/gal}}{38.2 \text{ ft}^3 \quad 1000 \text{ ft}^3} = 55 \text{ lb/day/1000 ft}^3$
- 5.127 $114 \text{ mg/L} \times 2.84 \text{ MGD} \times 8.34 \text{ lb/day} = 2700 \text{ lb/day}$
- 5.128 $\frac{131 \text{ mg/L}}{200 \text{ mg/L}} \times 100 = 65.5\%$
- 5.129 $156 \text{ mg/L} \times 1.44 \text{ MGD} \times 8.34 \text{ lb/gal} = 1873 \text{ lb/day}$
- 5.130 $\frac{2,880,000 \text{ gpd}}{0.785 \times 90 \text{ ft} \times 90 \text{ ft}} = 453 \text{ gpd/ft}^2$
- 5.131 $\frac{188 \text{ mg/L}}{210 \text{ mg/L}} \times 100 = 90\%$
- 5.132 $\frac{141 \text{ mg/L} \times 2.23 \text{ MGD} \times 8.34 \text{ lb/gal}}{30.1 \text{ ft}^3 \quad 1000 \text{ ft}^3} = 87 \text{ lb/day/1000 ft}^3$
- 5.133 $\frac{0.785 \times 90 \text{ ft} \times 90 \text{ ft} \times 6 \text{ ft}}{43,560 \text{ ft}^3/\text{ac-ft}} = 0.9 \text{ ac-ft}$
 $\frac{144 \text{ mg/L} \times 1.26 \text{ MGD} \times 8.34 \text{ lb/gal}}{0.9 \text{ ac-ft}} = 1681 \text{ lb/day/ac-ft}$
- 5.134 $178 \text{ mg/L} \times 4.22 \text{ MGD} \times 8.34 \text{ lb/gal} = 6265 \text{ lb/day}$
- 5.135 $3.8 \text{ MGD} \div 3.6 \text{ MGD} = 1.1$
- 5.136 $\frac{0.785 \times 80 \text{ ft} \times 80 \text{ ft}}{43,560 \text{ ft}^2/\text{ac}} = 0.12 \text{ ac}; \quad \frac{1.9 \text{ MGD}}{0.12 \text{ ac}} = 15.8 \text{ MGD/ac}$
 $\frac{1,930,000 \text{ gpd}}{0.785 \times 90 \text{ ft} \times 90 \text{ ft}} = 304 \text{ gpd/ft}^2$
- 5.138 $\frac{166 \text{ mg/L} \times 0.81 \text{ MGD} \times 8.34 \text{ lb/gal}}{23.1 \text{ ft}^3 \quad 1000 \text{ ft}^3} = 48 \text{ lb/day/1000 ft}^3$
- 5.139 $2.35 \text{ MGD} \div 1.67 \text{ MGD} = 1.4$
- 5.140 $\frac{208 \text{ mg/L}}{243 \text{ mg/L}} \times 100 = 86\%$

$$5.141 \quad \frac{2,980,000 \text{ gpd}}{720,000 \text{ ft}^2} = 4.1 \text{ gpd/ft}^2$$

$$5.142 \quad \frac{4,725,000 \text{ gpd}}{880,000 \text{ ft}^2} = 5.4 \text{ gpd/ft}^2$$

$$5.143 \quad \frac{1,550,000 \text{ gpd}}{440,000 \text{ ft}^2} = 3.5 \text{ gpd/ft}^2$$

$$5.144 \quad \frac{x \text{ gpd}}{800,000 \text{ ft}^2} = 7 \text{ gpd/ft}^2$$

$$x = 5,600,000 \text{ gpd}$$

$$5.145 \quad 241 \text{ mg/L} \times 0.55 \text{ K value} = 133 \text{ mg/L}$$

$$5.146 \quad 222 \text{ mg/L} = (241 \text{ mg/L} \times 0.5 \text{ K value}) + x \text{ mg/L}, \quad x = 102 \text{ mg/L}$$

$$5.147 \quad 240 \text{ mg/L} = 150 \text{ mg/L} \times 0.5 \text{ K value} + x \text{ mg/L}, \quad x = 165 \text{ mg/L}$$

$$5.148 \quad 288 \text{ mg/L} = (268 \text{ mg/L} \times 0.6 \text{ K value}) + x \text{ mg/L}, \quad x = 127 \text{ mg/L}$$

$$127 \text{ mg/L} \times 1.9 \text{ MGD} \times 8.34 \text{ lb/gal} = 2012 \text{ lb/day}$$

$$5.149 \quad \frac{160 \text{ mg/L} \times 4.35 \text{ MGD} \times 8.34 \text{ lb/gal}}{980 \text{ ft}^2 \quad 1000 \text{ ft}^2} = 5.9 \text{ lb/day/1000 ft}^2$$

$$5.150 \quad \frac{179 \text{ mg/L} \times 1.52 \text{ MGD} \times 8.34 \text{ lb/gal}}{640 \text{ ft}^2 \quad 1000 \text{ ft}^2} = 3.5 \text{ lb/day/1000 ft}^2$$

$$5.151 \quad \frac{128 \text{ mg/L} \times 2.82 \text{ MGD} \times 8.34 \text{ lb/gal}}{660 \text{ ft}^2 \quad 1000 \text{ ft}^2} = 4.6 \text{ lb/day/1000 ft}^2$$

$$5.152 \quad 187 \text{ mg/L} = (144 \text{ mg/L} \times 0.52) + x \text{ mg/L}, \quad x = 112 \text{ mg/L}$$

$$\frac{112 \text{ mg/L} \times 2.8 \text{ MGD} \times 8.34 \text{ lb/gal}}{765 \text{ ft}^2 \quad 1000 \text{ ft}^2} = 3.4 \text{ lb/day/1000 ft}^2$$

$$5.153 \quad \frac{450,000 \text{ gpd}}{190,000 \text{ ft}^2} = 2.4 \text{ gpd/ft}^2$$

$$5.154 \quad 190 \text{ mg/L} - (0.6 \times 210 \text{ mg/L}) = 64 \text{ mg/L}$$

$$5.155 \quad \frac{1.9 \text{ MGD} \times 128 \text{ mg/L} \times 8.34 \text{ lb/gal}}{410,000 \text{ ft}^2} \times 1000 = 4.9 \text{ lb/day/100 ft}^2$$

- 5.156 $210 \text{ mg/L} - (0.65 \times 240 \text{ mg/L}) = 54 \text{ mg/L}$

$$\frac{0.71 \text{ MGD} \times 54 \text{ mg/L} \times 8.34 \text{ lb/gal}}{110,000 \text{ ft}^2} \times 1000 = 2.9 \text{ lb/day/1000 ft}^2$$
- 5.157 *Hydraulic Loading*

$$\frac{455,000 \text{ gpd}}{206,000 \text{ ft}^2} = 2.2 \text{ gpd/ft}^2$$
- Unit Organic Loading*
 $241 \text{ mg/L} - (0.5 \times 149 \text{ mg/L}) = 166.5 \text{ mg/L}$
 $0.455 \text{ MGD} \times 166.5 \text{ mg/L} \times 8.34 \text{ lb/gal} = 632 \text{ lb/day}$

$$\frac{632 \text{ lb/day}}{206,000 \text{ ft}^2} \times 1000 = 3.1 \text{ lb/day/1000 ft}^2$$
- First-Stage Organic Loading*

$$\frac{632 \text{ lb/day}}{0.785 \times 103,000 \text{ ft}^2} \times 1000 = 8.2 \text{ lb/day/1000 ft}^2$$

$$\frac{632 \text{ lb/day}}{103,000 \text{ ft}^2} \times 1000 = 6.1 \text{ lb/day/1000 ft}^2$$
- 5.158
$$\frac{2,960,000 \text{ gpd}}{660,000 \text{ ft}^2} = 4.5 \text{ gpd/ft}^2$$
- 5.159 $222 \text{ mg/L} \times 0.5 \text{ K value} = 111 \text{ mg/L}$
- 5.160
$$\frac{151 \text{ mg/L} \times 1.92 \text{ MGD} \times 8.34 \text{ lb/gal}}{720 \text{ ft}^2 \times 1000 \text{ ft}^2} = 3.4 \text{ lb/day/1000 ft}^2$$
- 5.161 $210 \text{ mg/L} = 205 \text{ mg/L} \times 0.6) + x \text{ mg/L}, \quad x = 87 \text{ mg/L}$
 $87 \text{ mg/L} \times 2.9 \text{ MGD} \times 8.34 \text{ lb/gal} = 2104 \text{ lb/day}$
- 5.162
$$\frac{4,475,000 \text{ gpd}}{910,000 \text{ ft}^2} = 4.9 \text{ gpd/ft}^2$$
- 5.163
$$\frac{121 \text{ mg/L} \times 2.415 \text{ MGD} \times 8.34 \text{ lb/gal}}{760 \text{ ft}^2 \times 1000 \text{ ft}^2} = 3.2 \text{ lb/day/1000 ft}^2$$
- 5.164 $80 \text{ ft} \times 30 \text{ ft} \times 14 \text{ ft} \times 7.48 \text{ gal/ft}^3 = 251,328 \text{ gal}$
- 5.165 $80 \text{ ft} \times 30 \text{ ft} \times 12 \text{ ft} \times 7.48 \text{ gal/ft}^3 = 215,424 \text{ gal}$
- 5.166 $0.785 \times 80 \text{ ft} \times 80 \text{ ft} \times 12 \text{ ft} \times 7.48 \text{ gal/ft}^3 = 450,954 \text{ gal}$

$$5.167 \quad 0.785 \times 70 \text{ ft} \times 70 \text{ ft} \times 10 \text{ ft} \times 7.48 \text{ gal/ft}^3 = 287,718 \text{ gal}$$

$$5.168 \quad 240 \text{ mg/L} \times 0.88 \text{ MGD} \times 8.34 \text{ lb/gal} = 1761 \text{ lb/day}$$

$$5.169 \quad 160 \text{ mg/L} \times 4.29 \text{ MGD} \times 8.34 \text{ lb/gal} = 5725 \text{ lb/day}$$

$$5.170 \quad 165 \text{ mg/L} \times 3.24 \text{ MGD} \times 8.34 \text{ lb/gal} = 4459 \text{ lb/day}$$

$$5.171 \quad 150 \text{ mg/L} \times 4.88 \text{ MGD} \times 8.34 \text{ lb/gal} = 6105 \text{ lb/day}$$

$$5.172 \quad 2110 \text{ mg/L} \times 0.46 \text{ MG} \times 8.34 \text{ lb/gal} = 8095 \text{ lb}$$

$$5.173 \quad 2420 \text{ mg/L} \times 0.54 \text{ MG} \times 8.34 \text{ lb/gal} = 10,899 \text{ lb}$$

$$5.174 \quad 2410 \text{ mg/L} \times 0.38 \text{ MG} \times 8.34 \text{ lb/gal} = 7638 \text{ lb}$$

$$5.175 \quad 2740 \text{ mg/L} \times 0.39 \text{ MG} \times 8.34 \text{ lb/gal} = 8912 \text{ lb}$$

$$5.176 \quad 2470 \text{ mg/L} \times 0.66 \text{ MG} \times 8.34 \text{ lb/gal} \times 0.73 = 9925 \text{ lb}$$

$$5.177 \quad \frac{198 \text{ mg/L} \times 2.72 \text{ MGD} \times 8.34 \text{ lb/gal}}{2610 \text{ mg/L} \times 0.48 \text{ MG} \times 8.34} = 0.43$$

$$5.178 \quad \frac{148 \text{ mg/L} \times 3.35 \text{ MGD} \times 8.34 \text{ lb/gal}}{2510 \text{ mg/L} \times 0.49 \text{ MG} \times 8.34 \text{ lb/gal}} = 0.40$$

$$5.179 \quad \frac{180 \text{ mg/L} \times 0.32 \text{ MGD} \times 8.34 \text{ lb/gal}}{2540 \text{ mg/L} \times 0.195 \text{ MG} \times 8.34 \text{ lb/gal}} = 0.12$$

$$5.180 \quad \frac{181 \text{ mg/L} \times 3.3 \text{ MGD} \times 34 \text{ lb/gal}}{x \text{ lb}} = 0.7, \quad x = 7116 \text{ mg/L}$$

$$5.181 \quad \frac{141 \text{ mg/L} \times 2.51 \text{ MGD} \times 8.34 \text{ lb/gal}}{x \text{ lb}} = 0.4, \quad x = 7379 \text{ lb}$$

$$5.182 \quad \frac{16,100 \text{ lb}}{2630 \text{ lb/day}} = 6.1 \text{ days}$$

$$5.183 \quad \frac{2720 \text{ mg/L} \times 0.48 \text{ MG} \times 8.34 \text{ lb/gal}}{110 \text{ mg/L} \times 2.9 \text{ MGD} \times 8.34 \text{ lb/gal}} = 4.1 \text{ days}$$

$$5.184 \quad \frac{2510 \text{ mg/L} \times 0.57 \text{ MGD} \times 8.34 \text{ lb/gal}}{111 \text{ mg/L} \times 2.88 \text{ MGD} \times 8.34 \text{ lb/gal}} = 4.5 \text{ days}$$

$$5.185 \quad \frac{2960 \text{ mg/L} \times 0.58 \text{ MGD} \times 8.34 \text{ lb/gal}}{110 \text{ mg/L} \times 1.98 \text{ MGD} \times 8.34 \text{ lb/gal}} = 7.9 \text{ days}$$

$$5.186 \quad \frac{3810 \text{ mg/L} \times 0.211 \text{ MG} \times 8.34 \text{ lb/gal}}{205 \text{ mg/L} \times 0.27 \text{ MGD} \times 8.34 \text{ lb/gal}} = 14.6 \text{ days}$$

$$5.187 \quad \frac{29,100 \text{ lb}}{2920 \text{ lb/day} + 400 \text{ lb/day}} = 8.8 \text{ days}$$

$$5.188 \quad \frac{(2710 \text{ mg/L} \times 1.5 \text{ MG} \times 8.34 \text{ lb/gal}) + (1940 \text{ mg/L} \times 0.106 \text{ MG} \times 8.34 \text{ lb/gal})}{(5870 \text{ mg/L} \times 0.072 \text{ MGD} \times 8.34 \text{ lb/gal}) + (25 \text{ mg/L} \times 3.3 \text{ MGD} \times 8.34 \text{ lb/gal})} = \frac{33,902 \text{ lb} + 1715 \text{ lb}}{3225 \text{ lb/day} + 688 \text{ lb/day}}$$

$$= 9.1 \text{ days}$$

$$5.189 \quad \frac{2222 \text{ mg/L} \times 0.612 \text{ MG} \times 8.34 \text{ lb/gal}}{1610 \text{ lb/day} + 240 \text{ lb/day}} = 6.1 \text{ days}$$

$$5.190 \quad \frac{2910 \text{ mg/L} \times 0.475 \text{ MG} \times 8.34 \text{ lb/gal}}{(6210 \text{ mg/L} \times 0.027 \text{ MGD} \times 8.34 \text{ lb/gal}) + (16 \text{ mg/L} \times 1.4 \text{ MGD} \times 8.34 \text{ lb/gal})} = \frac{11,528}{1398 \text{ lb/day} + 187 \text{ lb/day}}$$

$$= 7.3 \text{ days}$$

$$5.191 \quad \frac{220 \text{ mL/L}}{1000 \text{ mL/L} - 220 \text{ mL/L}} = 0.28$$

$$5.192 \quad \frac{2480 \text{ mg/L} \times (3.6 \text{ MGD} + x \text{ MGD}) \times 8.34 \text{ lb/gal}}{8.34 \text{ lb/gal} + (7840 \text{ mg/L} \times 0.061 \text{ MGD}) \times 8.34 \text{ lb/gal}} = \frac{(7840 \text{ mg/L} \times x \text{ MGD})}{(7840 \text{ mg/L} \times x \text{ MGD})}$$

$$2480 \text{ mg/L} \times (3.6 \text{ MGD} + x \text{ MGD}) = (7840 \text{ mg/L} \times x \text{ MGD})$$

$$+ (7840 \text{ mg/L} \times 0.061 \text{ mg/L})$$

$$8928 + 2480x = 7840x + 478$$

$$8450 = 5360x$$

$$x = 1.58 \text{ MGD}$$

$$5.193 \quad \frac{280 \text{ mL/L}}{1000 \text{ mL/L} - 280 \text{ mL/L}} = 0.39$$

$$5.194 \quad 7520 \text{ mg/L} \times x \text{ MGD} \times 8.34 = 2200 \text{ mg/L} \times (6.4 \text{ MGD} + x \text{ MGD}) \times 8.34$$

$$7520 \times x \text{ MGD} = 2200 \times 6.4 + x \text{ MGD}$$

$$7520x = 14,080 + 2200x$$

$$5320x = 14,080$$

$$x = 2.65 \text{ MGD}$$

- 5.195 $\frac{3400 \text{ lb/day}}{x \text{ lb/day} \times 69/100} = 0.5, \quad x = 9565 \text{ lb}$
- 5.196 $2710 \text{ mg/L} \times 0.79 \text{ MG} \times 8.34 \text{ lb/gal} = 17,855 \text{ lb}$
 $17,855 \text{ lb} - 14,900 \text{ lb} = 2955 \text{ lb}$
- 5.197 $\frac{110 \text{ mg/L} \times 3.10 \text{ MGD} \times 8.34 \text{ lb/gal}}{x \text{ lb} \times 68/100} = 0.4; \quad x = 10,456 \text{ lb desired}$
 $2200 \text{ mg/L} \times 1.1 \text{ MG} \times 8.34 \text{ lb/gal} = 20,183 \text{ lb actual}$
 $20,183 \text{ lb actual} - 10,456 \text{ lb desired} = 9727 \text{ lb wasted}$
- 5.198 $\frac{x \text{ lb}}{3220 \text{ lb/day}} = 5.6 \text{ days}; \quad x = 18,032 \text{ lb desired}$
 $2900 \text{ mg/L} \times .910 \text{ MG} \times 8.34 \text{ lb/gal} = 22,009 \text{ lb actual}$
 $22,009 \text{ lb actual} - 18,032 \text{ lb desired} = 3977 \text{ lb wasted}$
- 5.199 $\frac{32,400 \text{ lb}}{x \text{ lb/day WAS} + (23 \text{ mg/L} \times 3.22 \text{ MGD} \times 8.34 \text{ lb/gal})} = 9 \text{ days}$
 $\text{WAS Pumping Rate} = \frac{32,400 \text{ lb}}{x \text{ lb/day} + 618 \text{ lb/day}} = 9 \text{ days}$
 $\frac{32,400}{9} = x + 618$
 $3600 = x + 618$
 $2982 \text{ lb/day} = x$
- 5.200 $6640 \text{ mg/L} \times x \text{ MGD} \times 8.34 \text{ lb/gal} = 5580 \text{ lb/day}, \quad x = 0.10 \text{ MGD}$
- 5.201 $6200 \text{ mg/L} \times x \text{ MGD} \times 8.34 \text{ lb/gal} = 8710 \text{ lb/day}, \quad x = 0.17 \text{ MGD}$
- 5.202 $\frac{2725 \text{ mg/L} \times 1.8 \text{ MG} \times 8.34 \text{ lb/gal}}{(7420 \text{ mg/L} \times x \text{ MGD} \times 8.34 \text{ lb/gal}) + (18 \text{ mg/L} \times 4.3 \text{ MGD} \times 8.34 \text{ lb/gal})} = 9 \text{ days}$
 $\frac{40,908 \text{ lb}}{(7420 \text{ mg/L} \times x \text{ MGD} \times 8.34 \text{ lb/gal}) + 646 \text{ lb/day}} = 9 \text{ days}$
 $\frac{40,908}{9} = (7420 \times x \times 8.34) + 646$
 $4545 = (7420 \times x \times 8.34) + 646$
 $3899 = (7420 \times x \times 8.34)$
 $x = 0.063 \text{ MGD}$

$$5.203 \quad \frac{2610 \text{ mg/L} \times 1.7 \text{ MG} \times 8.34 \text{ lb/gal}}{(6140 \text{ mg/L} \times x \text{ MGD} \times 8.34 \text{ lb/gal}) + (14 \text{ mg/L} \times 3.8 \text{ MGD} \times 8.34 \text{ lb/gal})} = 8.5 \text{ days}$$

$$\frac{37,005 \text{ lb MLSS}}{(6140 \text{ mg/L} \times x \text{ MGD} \times 8.34 \text{ lb/gal}) + 444 \text{ lb/day}} = 8.5 \text{ days}$$

$$\frac{37,005}{8.5} = (6140 \times x \times 8.34) + 444$$

$$4354 = (6140 \times x \times 8.34) + 444$$

$$3910 = 6140 \times x \times 8.34$$

$$x = 0.076 \text{ MGD}$$

$$5.204 \quad \frac{166,000 \text{ gal}}{7917 \text{ gal/hr}} = 21 \text{ hr}$$

$$5.205 \quad \frac{370,000 \text{ gal}}{9583 \text{ gal/hr}} = 39 \text{ hr}$$

$$5.206 \quad \frac{420,000 \text{ gal}}{12,708 \text{ gal/hr}} = 33 \text{ hr}$$

$$5.207 \quad \frac{210,000 \text{ gal}}{12,917 \text{ gal/hr}} = 16 \text{ hr}$$

$$5.208 \quad 80 \text{ ft} \times 40 \text{ ft} \times 15 \text{ ft} \times 7.48 \text{ gal/ft}^3 = 359,040 \text{ gal}$$

$$5.209 \quad 220 \text{ mg/L} \times 1.72 \text{ MGD} \times 8.34 \text{ lb/gal} = 3156 \text{ lb/day}$$

$$5.210 \quad \frac{222 \text{ mg/L} \times 0.399 \text{ MGD} \times 8.34 \text{ lb/gal}}{3340 \times 0.22 \text{ MG} \times 8.34 \text{ lb/gal} \times 68/100} = 0.18$$

$$5.211 \quad 0.785 \times 90 \text{ ft} \times 90 \text{ ft} \times 12 \text{ ft} \times 7.48 \text{ gal/ft}^3 = 570,739 \text{ gal}$$

$$5.212 \quad 160 \text{ mg/L} \times 3.92 \text{ MGD} \times 8.34 \text{ lb/gal} = 5231 \text{ lb/day}$$

$$5.213 \quad \frac{2700 \text{ mg/L} \times 0.53 \text{ MG} \times 8.34 \text{ lb/gal}}{190 \text{ mg/L} \times 1.8 \text{ MGD} \times 8.34 \text{ lb/day}} = 4.2 \text{ days}$$

$$5.214 \quad \frac{440 \text{ mL}}{2100 \text{ mL} - 440 \text{ mL}} = \frac{440 \text{ mL}}{1660 \text{ mL}} = 0.265$$

$$0.265 \times 6.1 \text{ MGD} = 1.62 \text{ MGD}$$

$$\frac{1.62 \text{ MG}}{1} \times \frac{1 \text{ day}}{1440 \text{ min}} \times \frac{1,000,000 \text{ gal}}{1 \text{ million gal}} = 1125 \text{ gpm}$$

- 5.215 $2100 \text{ mg/L} - 2050 \text{ mg/L} = 50 \text{ mg/L}$ in excess
 $50 \text{ mg/L} \times 0.45 \text{ MG} \times 8.34 \text{ lb/gal} = 188 \text{ lb}$
 $188 \text{ lb/day} = 4920 \text{ mg/L} \times x \text{ MGD} \times 8.34 \text{ lb/gal}$
 $\frac{188}{4920 \times 8.34} = x = 0.0046 \text{ MGD additional WAS}$
New WAS = $0.120 \text{ MGD} + 0.0046 \text{ MGD} = 0.125 \text{ MGD}$
- 5.216 -80 ; we need an extra 80 mg/L MLSS in aeration
 $80 \text{ mg/L} \times 0.44 \text{ MG} \times 8.34 \text{ lb/gal} = 294 \text{ lb}$ needed
 $294 \text{ lb/day} = 4870 \text{ mg/L} \times x \text{ MGD} \times 8.34 \text{ lb/gal}$
 $\frac{294}{4870 \times 8.34} = x = 0.007 \text{ MGD}$
WAS = $\frac{87.3 \text{ gpm} \times 1440 \text{ min/day}}{1,000,000 \text{ gal}} = 0.126 \text{ MGD}$
New WAS = $0.126 \text{ MGD} - 0.007 \text{ MGD} = 0.119 \text{ MGD}$
 $\frac{0.119 \text{ MGD} \times 1,000,000 \text{ gal}}{1440 \text{ min}} = 83 \text{ gpm}$
- 5.217 **Sludge Age = $\frac{2210 \text{ mg/L} \times 0.66 \text{ MG} \times 8.34 \text{ lb/gal}}{131 \text{ mg/L} \times 3.25 \text{ MGD} \times 8.34 \text{ lb/gal}}$**
 $= \frac{1459 \text{ lb}}{426 \text{ lb/day}} = 3.42 \text{ days}$
- 5.218 $\frac{146 \text{ mg/L} \times 2.88 \text{ MGD} \times 8.34 \text{ lb/gal}}{x \text{ lb}} = 0.6, \quad x = 5845 \text{ lb}$
- 5.219 $\frac{310,000 \text{ gal}}{17,083 \text{ gal/hr}} = 18 \text{ hr}$
- 5.220 $\frac{161 \text{ mg/L} \times 2.41 \text{ MGD} \times 8.34 \text{ lb/gal}}{x \text{ lb}} = 0.8, \quad x = 4045 \text{ lb}$
- 5.221 $\frac{2910 \text{ mg/L} \times 0.46 \text{ MGD} \times 8.34 \text{ lb/gal}}{170 \text{ mg/L} \times 1.4 \text{ MG} \times 8.34 \text{ lb/gal}} = 5.8 \text{ days}$
- 5.222 $\frac{620,000 \text{ gal}}{15,000 \text{ gal/hr}} = 41.3 \text{ hr}$
- 5.223 $\frac{3980 \text{ mg/L} \times 0.26 \text{ MGD} \times 8.34 \text{ lb/gal}}{200 \text{ mg/L} \times 0.4 \text{ MGD} \times 8.34 \text{ lb/gal}} = 13.0 \text{ days}$

$$5.224 \quad 2710 \text{ mg/L} \times 0.44 \text{ MG} \times 8.34 \text{ lb/gal} = 9945 \text{ lb}$$

$$5.225 \quad \frac{146 \text{ mg/L} \times 2.88 \text{ MGD} \times 8.34 \text{ lb/gal}}{x \text{ lb}} = 0.4, \quad x = 8767 \text{ lb}$$

$$5.226 \quad 2510 \text{ mg/L} \times 0.59 \text{ MG} \times 8.34 \text{ lb/gal} = 12,351 \text{ lb}$$

$$5.227 \quad \frac{2740 \text{ mg/L} \times 0.710 \text{ MGD} \times 8.34 \text{ lb/gal}}{184 \text{ mg/L} \times 1.86 \text{ MGD} \times 8.34 \text{ lb/gal}} = 5.7 \text{ days}$$

$$5.228 \quad \begin{aligned} & (2680 \text{ mg/L} \times 1.41 \text{ MG} \times 8.34 \text{ lb/gal}) \\ & + (1910 \text{ mg/L} \times 0.118 \text{ MG} \times 8.34 \text{ lb/gal}) \\ & (5870 \text{ mg/L} \times 0.076 \text{ MGD} \times 8.34 \text{ lb/gal}) \\ & + (20 \text{ mg/L} \times 3.1 \text{ MGD} \times 8.34 \text{ lb/gal}) \\ & = \frac{31,515 + 1854}{3721 + 517} = 7.9 \text{ days} \end{aligned}$$

$$5.229 \quad 231 \text{ mL/L} \div 769 \text{ mL/L} = 0.30$$

$$5.230 \quad \frac{3720 \text{ lb/day}}{x \text{ lb MLSS} \times 70/100} = 0.5, \quad x = 10,629 \text{ lb}$$

$$5.231 \quad \frac{x \text{ lb MLSS}}{3740 \text{ lb/day SS}} = 5 \text{ days}, \quad x = 18,700 \text{ lb}$$

$$2810 \text{ mg/L} \times 0.78 \text{ MG} \times 8.34 \text{ lb/gal} = 18,280 \text{ lb MLSS}$$

No MLSS should be wasted.

$$5.232 \quad 6410 \text{ mg/L} \times x \text{ MGD} \times 8.34 \text{ lb/gal} = 4110 \text{ lb/day}, \quad x = 0.077 \text{ MGD}$$

$$5.233 \quad 250 \text{ mg/L} \times 0.41 \text{ MGD} \times 8.34 \text{ lb/gal} = 855 \text{ lb/day}$$

$$5.234 \quad 161 \text{ mg/L} \times 0.225 \text{ MGD} \times 8.34 \text{ lb/gal} = 302 \text{ lb/day}$$

$$5.235 \quad 223 \text{ mg/L} \times 0.259 \text{ MGD} \times 8.34 \text{ lb/gal} = 482 \text{ lb/day}$$

$$5.236 \quad 200 \text{ mg/L} \times 0.19 \text{ MGD} \times 8.34 \text{ lb/gal} = 317 \text{ lb/day}$$

$$5.237 \quad \frac{192 \text{ mg/L} \times 0.219 \text{ MGD} \times 8.34 \text{ lb/gal}}{7.8 \text{ ac}} = 45 \text{ lb/day/ac}$$

$$5.238 \quad \frac{145 \text{ mg/L} \times 0.167 \text{ MGD} \times 8.34 \text{ lb/gal}}{7.1 \text{ ac}} = 28.4 \text{ lb/day/ac}$$

$$5.239 \quad \frac{128 \text{ mg/L} \times 0.072 \text{ gpd} \times 8.34 \text{ lb/gal}}{2.2 \text{ ac}} = 35 \text{ lb/day/ac}$$

$$5.240 \quad \frac{189 \text{ mg/L} \times x \text{ MGD} \times 8.34 \text{ lb/gal}}{15 \text{ ac}} = 22 \text{ lb}, \quad x = 0.21 \text{ MGD}$$

$$5.241 \quad \frac{169 \text{ mg/L}}{210 \text{ mg/L}} \times 100 = 80\%$$

$$5.242 \quad \frac{140 \text{ mg/L}}{267 \text{ mg/L}} \times 100 = 52\%$$

$$5.243 \quad \frac{246 \text{ mg/L}}{290 \text{ mg/L}} \times 100 = 85\%$$

$$5.244 \quad \frac{84 \text{ mg/L}}{142 \text{ mg/L}} \times 100 = 59\%$$

$$5.245 \quad \frac{3.6 \text{ ac-ft/day}}{22 \text{ ac}} = 0.164 \text{ ft/day} = 0.165 \text{ ft/day} \times 12 \text{ in./ft} = 2 \text{ in./day}$$

$$5.246 \quad \frac{6 \text{ ac-ft/day}}{16 \text{ ac}} = 0.38 \text{ ft/day}$$

$$0.38 \text{ ft/day} \times 12 \text{ in./ft} = 4.6 \text{ in./day}$$

$$5.247 \quad \frac{2,410,000 \text{ gpd}}{7.48 \text{ gal/ft}^3 \times 43,560 \text{ ft}^3/\text{ac-ft}} = 7.4 \text{ ac-ft}$$

$$\frac{7.4 \text{ ac-ft/day}}{17 \text{ ac}} = 0.44 \text{ ft/day}$$

$$0.44 \text{ ft/day} \times 12 \text{ in./ft} = 5.3 \text{ in./day}$$

$$5.248 \quad 16 \text{ ac} \times 43,560 \text{ ft}^2/\text{ac} = 696,960 \text{ ft}^2$$

$$\frac{1,880,000 \text{ gpd}}{696,960 \text{ ft}^2} = 2.70 \text{ gpd/ft}^2$$

$$\frac{2.70 \text{ gpd/ft}^2 \times 1.6 \text{ in./day}}{\text{gpd/ft}^2} = 4.3 \text{ in./day}$$

$$5.249 \quad \frac{1340 \text{ people}}{5 \text{ ac}} = 268 \text{ people/ac}$$

$$5.250 \quad \frac{5580 \text{ people}}{19 \text{ ac}} = 294 \text{ people/ac}$$

$$5.251 \quad \frac{1640 \text{ mg/L} \times 0.8 \text{ MGD} \times 8.34 \text{ lb/gal}}{0.2 \text{ lb/day/person}} = 54,710 \text{ people}$$

$$5.252 \quad \frac{2260 \text{ mg/L} \times 0.257 \text{ MGD} \times 8.34 \text{ lb/gal}}{0.2 \text{ lb/day/person}} = 24,220 \text{ people}$$

$$5.253 \quad \frac{19 \text{ ac-ft}}{0.44 \text{ ac-ft/day}} = 43 \text{ days}$$

$$5.254 \quad \frac{450 \text{ ft} \times 700 \text{ ft} \times 8 \text{ ft} \times 7.48 \text{ gal/ft}^3}{300,000 \text{ gpd}} = 63 \text{ days}$$

$$5.255 \quad \frac{250 \text{ ft} \times 400 \text{ ft} \times 6 \text{ ft} \times 7.48 \text{ gal/ft}^3}{72,000 \text{ gpd}} = 62 \text{ days}$$

$$5.256 \quad \frac{33 \text{ ac}}{0.48 \text{ ac-ft/day}} = 69 \text{ days}$$

$$5.257 \quad 720 \text{ ft} \times 460 \text{ ft} \times 6 \text{ ft} \times 7.48 \text{ gal/ft}^3 = 14,864,256 \text{ gal}$$

$$\frac{14,864,256 \text{ gal}}{310,000 \text{ gal/day}} = 48 \text{ days}$$

$$5.258 \quad 705 \text{ ft} \times 430 \text{ ft} \times 4.17 \text{ ft} = 1,264,136 \text{ ft}^3$$

$$0.50 \text{ ac-ft/day} \times 43,560 \text{ ft}^3 = 21,780 \text{ ft}^3/\text{day}$$

$$\frac{1,264,136 \text{ ft}^3}{21,780 \text{ ft}^3} = 58 \text{ days}$$

$$5.259 \quad 0.16 \text{ MGD} \times 171 \text{ mg/L} \times 8.34 \text{ lb/gal} = 228.2 \text{ lb/day}$$

$$\frac{698 \text{ ft} \times 395 \text{ ft}}{43,560 \text{ ft}^2} = 6.33 \text{ ac}$$

$$\frac{228.2 \text{ lb/day}}{6.33 \text{ ac}} = 36.1 \text{ lb/day ac}$$

$$5.260 \quad \frac{750 \text{ ft} \times 435 \text{ ft}}{43,560 \text{ ft}^2} = 7.49 \text{ ac}$$

$$\frac{0.79 \text{ ac-ft/day} \times 12 \text{ in./ft}}{7.49 \text{ ac}} = 1.27 \text{ in./day}$$

$$5.261 \quad 192 \text{ mg/L} \times 0.37 \text{ MGD} \times 8.34 \text{ lb/day} = 592 \text{ lb/day}$$

$$5.262 \quad \frac{240 \text{ mg/L} \times 0.285 \text{ MGD} \times 8.34 \text{ lb/gal}}{9.1 \text{ ac}} = 63 \text{ lb/day/ac}$$

$$5.263 \quad \frac{176 \text{ mg/L}}{220 \text{ mg/L}} \times 100 = 80\%$$

- 5.264 $\frac{3.8 \text{ ac-ft/day}}{22 \text{ ac}} = 0.17 \text{ ft/day}$
 $0.17 \text{ ft/day} \times 12 \text{ in./day} = 2 \text{ in./day}$
- 5.265 $\frac{93 \text{ mg/L}}{166 \text{ mg/L}} \times 100 = 56\%$
- 5.266 $222 \text{ mg/L} \times 0.302 \text{ MGD} \times 8.34 \text{ lb/gal} = 559 \text{ lb/day}$
- 5.267 $\frac{135 \text{ mg/L} \times 0.080 \text{ MGD} \times 8.34 \text{ lb/gal}}{\frac{400 \text{ ft} \times 220 \text{ ft}}{43,560 \text{ ft}^2/\text{ac}}} = 45 \text{ lb/day/ac}$
- 5.268 $\frac{1,980,000 \text{ gpd}}{21 \text{ ac} \times 43,560 \text{ ft}^2/\text{ac}} = 2.2 \text{ gpd/ft}^2$
 $\frac{2.2 \text{ gpd/ft}^2 \times 1.6 \text{ in./day}}{\text{gpd/ft}^2} = 3.5 \text{ in./day}$
- 5.269 $\frac{6200 \text{ people}}{22 \text{ ac}} = 282 \text{ people/ac}$
- 5.270 $\frac{18.4 \text{ ac-ft}}{0.52 \text{ ac-ft/day}} = 35 \text{ days}$
- 5.271 $\frac{2910 \text{ mg/L} \times 0.9 \text{ MGD} \times 8.34 \text{ lb/gal}}{0.4 \text{ lb/day/person}} = 54,606 \text{ people}$
- 5.272 $\frac{440 \text{ ft} \times 730 \text{ ft} \times 6 \text{ ft} \times 7.48 \text{ gal/ft}^3}{450,000 \text{ gpd}} = 32 \text{ days}$
- 5.273 $3.4 \text{ mg/L} \times 4.6 \text{ MGD} \times 8.34 \text{ lb/gal} = 130 \text{ lb/day}$
- 5.274 $11 \text{ mg/L} \times 1.68 \text{ MGD} \times 8.34 \text{ lb/gal} = 154 \text{ lb/day}$
- 5.275 $2200 \text{ mg/L} \times 0.200 \text{ MGD} \times 8.34 \text{ lb/gal} = 3670 \text{ lb/day}$
- 5.276 $x \text{ mg/L} \times 5.12 \text{ MGD} \times 8.34 \text{ lb/gal} = 320 \text{ lb/day}, \quad x = 7.5 \text{ mg/L}$
- 5.277 $4.9 \text{ mg/L} + 0.8 \text{ mg/L} = 5.7 \text{ mg/L}$
- 5.278 $8.8 \text{ mg/L} = x \text{ mg/L} + 0.9 \text{ mg/L}, \quad x = 7.9 \text{ mg/L}$
- 5.279 $7.9 \text{ mg/L} + 0.6 \text{ mg/L} = 8.5 \text{ mg/L}$

$$5.280 \quad 10.7 \text{ mg/L} \times 4.0 \text{ MGD} \times 8.34 \text{ lb/gal} = 357 \text{ lb/day}$$

$$5.281 \quad \frac{11.1 \text{ mg/L} \times 2.88 \text{ MGD} \times 8.34 \text{ lb/gal}}{65/100} = 410 \text{ lb/day}$$

$$5.282 \quad \frac{9.8 \text{ mg/L} \times 4.1 \text{ MGD} \times 8.34 \text{ lb/gal}}{60/100} = 559 \text{ lb/day}$$

$$5.283 \quad \frac{19 \text{ mg/L} \times 1.724 \text{ MGD} \times 8.34 \text{ lb/gal}}{65/100} = 420 \text{ lb/day}$$

$$5.284 \quad \frac{x \text{ mg/L} \times 5.65 \text{ MGD} \times 8.34 \text{ lb/gal}}{65/100} = 950 \text{ lb}, \quad x = 13 \text{ mg/L}$$

$$5.285 \quad \frac{0.75 \text{ lb}}{(16 \text{ gal} \times 8.34 \text{ lb/gal}) + (0.75 \text{ lb})} \times 100 = 0.56\%$$

$$5.286 \quad \frac{x \text{ lb}}{(24 \text{ gal} \times 8.34 \text{ lb/gal}) + x \text{ lb}} \times 100 = 0.9$$

$$\frac{100x}{200 \text{ lb} + x \text{ lb}} = 0.9$$

$$100x = 0.9 \times (200 + x)$$

$$100x = 180 + 0.9x$$

$$99.1x = 180$$

$$x = 1.8 \text{ lb}$$

$$5.287 \quad 160 \text{ g} = 0.35 \text{ lb}$$

$$\frac{0.35 \text{ lb}}{(12 \text{ gal} \times 8.34 \text{ lb/gal}) + 0.3 \text{ lb}} \times 100 = 0.3\%$$

$$5.288 \quad (10/100) \times x \text{ lb} = (0.5/100) \times 172 \text{ lb}, \quad x = 8.6 \text{ lb}$$

$$5.289 \quad (10/100) \times x \text{ gal} \times 10.4 \text{ lb/gal} = (0.3/100) \times 55 \text{ gal} \times 8.34 \text{ lb/gal}$$

$$x = 1.3 \text{ gal}$$

$$5.290 \quad (12/100) \times x \text{ gal} \times 10.3 \text{ lb/gal} = (0.6/100) \times 111 \text{ gal} \times 8.34 \text{ lb/gal}$$

$$x = 4.5 \text{ gal}$$

$$5.291 \quad \frac{[(10/100) \times 26 \text{ lb}] + [(0.5/100) \times 110 \text{ lb}]}{26 \text{ lb} + 110 \text{ lb}} \times 100 = \frac{3.15 \text{ lb}}{136 \text{ lb}} \times 100 = 2.3\%$$

$$5.292 \quad \frac{[(12/100) \times 6 \text{ gal} \times 10.2 \text{ lb/gal}] + [(0.3/100) \times 30 \text{ gal} \times 8.4 \text{ lb/gal}]}{(6 \text{ gal} \times 10.2 \text{ lb/gal}) + (30 \text{ gal} \times 8.34 \text{ lb/gal})} \times 100$$

$$= \frac{7.3 \text{ lb} + 0.8 \text{ lb}}{61 \text{ lb} + 250 \text{ lb}} \times 100 = 2.6\%$$

$$5.293 \quad \frac{[(10/100) \times 12 \text{ gal} \times 10.2 \text{ lb/gal}] + [(0.28/100) \times 42 \text{ gal} \times 8.34 \text{ lb/gal}]}{(12 \text{ gal} \times 10.2 \text{ lb/gal}) + (42 \text{ gal} \times 8.34 \text{ lb/gal})} \times 100$$

$$= \frac{12.24 \text{ lb} + 0.98 \text{ lb}}{122.4 \text{ lb} + 350.3 \text{ lb}} \times 100 = 2.8\%$$

$$5.294 \quad 10 \text{ mg/L} \times 4.10 \text{ MGD} \times 8.34 \text{ lb/gal} = 342 \text{ lb/day}$$

$$\frac{342 \text{ lb/day}}{5.88 \text{ lb/gal}} = 58 \text{ gpd}$$

$$5.295 \quad 8 \text{ mg/L} \times 1.44 \text{ MGD} \times 8.34 \text{ lb/gal} = 96 \text{ lb/day}$$

$$\frac{96 \text{ lb/day}}{6.15 \text{ lb}} = 15.6 \text{ gpd}$$

$$5.296 \quad 11 \text{ mg/L} \times 2.13 \text{ MGD} \times 8.34 \text{ lb/gal} = 600,000 \text{ mg/L} \times x \text{ MGD} \times 8.34 \text{ lb/gal}$$

$$x = 0.000039 \text{ MGD, or } 39 \text{ gpd}$$

$$5.297 \quad 9 \text{ mg/L} \times 4.44 \text{ MGD} \times 8.34 \text{ lb/gal} = 600,000 \text{ mg/L} \times x \text{ MGD} \times 8.34 \text{ lb/gal}$$

$$x = 0.0000666 \text{ MGD, or } 66.6 \text{ gpd}$$

$$5.298 \quad (30 \text{ gpm}/80 \text{ gpm}) \times 100 = 37.5\%$$

$$5.299 \quad (22 \text{ gpm}/80 \text{ gpm}) \times 100 = 27.5\%$$

$$5.300 \quad (14 \text{ gpm}/70 \text{ gpm}) \times 100 = 20\%$$

$$5.301 \quad (40 \text{ gpm}/110 \text{ gpm}) \times 100 = 36\%$$

$$5.302 \quad \frac{35 \text{ gpd} \times 3785 \text{ mL/gal}}{1440 \text{ min/day}} = 92 \text{ mL/min}$$

$$5.303 \quad \frac{45 \text{ gal/day} \times 3785 \text{ mL/gal}}{1440 \text{ min/day}} = 118 \text{ mL/min}$$

$$\begin{aligned}
 5.304 \quad & 9 \text{ mg/L} \times 0.91 \text{ MGD} \times 8.34 \text{ lb/gal} \\
 & = 600,000 \text{ mg/L} \times x \text{ MGD} \times 8.34 \text{ lb/gal} \\
 & x = 0.000136 \text{ MGD, or } 13.6 \text{ gpd} \\
 & \frac{13.6 \text{ gal/day} \times 3785 \text{ mL/gal}}{1440 \text{ min/day}} = 36 \text{ mL/min}
 \end{aligned}$$

$$\begin{aligned}
 5.305 \quad & 11 \text{ mg/L} \times 1.42 \text{ MGD} \times 8.34 \text{ lb/gal} \\
 & = 600,000 \text{ mg/L} \times x \text{ MGD} \times 8.34 \text{ lb/gal} \\
 & x = 0.000026 \text{ MGD, or } 26 \text{ gpd} \\
 & \frac{26 \text{ gal/day} \times 3785 \text{ mL/gal}}{1440 \text{ min/day}} = 68 \text{ mL/min}
 \end{aligned}$$

$$\begin{aligned}
 5.306 \quad & \frac{2.1 \text{ lb}}{30 \text{ min}} = 0.07 \text{ lb/min} \\
 & 0.07 \text{ lb/min} \times 1440 \text{ min/day} = 101 \text{ lb/day}
 \end{aligned}$$

$$\begin{aligned}
 5.307 \quad & \frac{1.5 \text{ lb}}{30 \text{ min}} = 0.05 \text{ lb/min} \\
 & 0.05 \text{ lb/min} \times 1440 \text{ min/day} = 72 \text{ lb/day}
 \end{aligned}$$

$$\begin{aligned}
 5.308 \quad & 12 \text{ oz.} = 0.75 \text{ lb} \\
 & (2.10 \text{ lb container} + \text{chemical}) - (.75 \text{ lb container}) = 1.35 \text{ lb chemical} \\
 & \frac{1.35 \text{ lb}}{30 \text{ min}} = 0.045 \text{ lb/min} \\
 & 0.045 \text{ lb/min} \times 1440 \text{ min/day} = 65 \text{ lb/day}
 \end{aligned}$$

$$\begin{aligned}
 5.309 \quad & (2.5 \text{ lb container} + \text{chemical}) - (0.5 \text{ lb container}) = 2.0 \text{ lb chemical} \\
 & \frac{2.0 \text{ lb}}{30 \text{ min}} = 0.067 \text{ lb/min} \\
 & 0.067 \text{ lb/min} \times 1440 \text{ min/day} = 96.5 \text{ lb/day}
 \end{aligned}$$

$$\begin{aligned}
 5.310 \quad & \frac{770 \text{ mL}}{5 \text{ min}} = 154 \text{ mL/min} \\
 & \frac{154 \text{ mL/min} \times 1 \text{ gal} \times 1440 \text{ min/day}}{3785 \text{ mL}} = 59 \text{ gpd} \\
 & 14,000 \text{ mg/L} \times 0.000059 \text{ MGD} \times 8.34 \text{ lb/gal} = 6.9 \text{ lb/day}
 \end{aligned}$$

$$5.311 \quad \frac{900 \text{ mL}}{5 \text{ min}} = 180 \text{ mL/min}$$

$$\frac{180 \text{ mL}}{\text{min}} \times \frac{1 \text{ L}}{1000 \text{ mL}} \times \frac{1 \text{ gal}}{3785 \text{ L}} \times 1440 \text{ min/day} = 66.0 \text{ gpd}$$

$$12,000 \text{ mg/L} \times 0.000066 \text{ MGD} \times 8.34 \text{ lb/gal} = 6.6 \text{ lb/day}$$

$$5.312 \quad \frac{610 \text{ mL}}{5 \text{ min}} = 122 \text{ mL/min}$$

$$\frac{122 \text{ mL/min} \times 1 \text{ gal}}{3785 \text{ L}} \times 1440 \text{ min/day} = 46 \text{ gpd}$$

$$13,000 \text{ mg/L} \times 0.000046 \text{ MGD} \times 8.34 \text{ lb/gal} \times 1.2 = 6.0 \text{ lb/day}$$

$$5.313 \quad \frac{800 \text{ mL}}{5 \text{ min}} = 160 \text{ mL/min}$$

$$\frac{160 \text{ mL}}{\text{min}} \times \frac{1 \text{ gal}}{3785 \text{ L}} \times \frac{1440 \text{ min}}{\text{day}} = 61 \text{ gpd}$$

$$5000 \text{ mg/L} \times 0.000061 \text{ MGD} \times 8.34 \text{ lb/gal} \times 1.15 = 2.9 \text{ lb/day}$$

$$5.314 \quad \frac{0.785 \times 4 \text{ ft} \times 4 \text{ ft} \times 1.5 \text{ ft} \times 7.48 \text{ gal/ft}^3}{3 \text{ min}} = 47 \text{ gpm}$$

$$5.315 \quad \frac{0.785 \times 5 \text{ ft} \times 5 \text{ ft} \times 1.25 \text{ ft} \times 7.48 \text{ gal/ft}^3}{5 \text{ min}} = 37 \text{ gpm}$$

$$5.316 \quad \frac{0.785 \times 5 \text{ ft} \times 5 \text{ ft} \times x \text{ ft} \times 7.48 \text{ gal/ft}^3}{4 \text{ min}} = 30, \quad x = 0.8 \text{ ft}$$

$$5.317 \quad \frac{0.785 \times 5 \text{ ft} \times 5 \text{ ft} \times 1.6 \text{ ft} \times 7.48 \text{ gal/ft}^3}{3 \text{ min}} = 78 \text{ gpm}$$

$$5.318 \quad \frac{537 \text{ lb}}{7 \text{ day}} = 77 \text{ lb/day average}$$

$$5.319 \quad \frac{2300 \text{ lb}}{115 \text{ lb/day}} = 20 \text{ days}$$

$$5.320 \quad \frac{1002 \text{ lb}}{66 \text{ lb/day}} = 15.2 \text{ days}$$

$$5.321 \quad 0.785 \times 5 \text{ ft} \times 5 \text{ ft} \times 3.4 \text{ ft} \times 7.48 \text{ gal/ft}^3 = 499 \text{ gal}$$

$$\frac{499 \text{ gal}}{97 \text{ gpd}} = 5.1 \text{ days}$$

$$5.322 \quad 11 \text{ mg/L} \times 3.75 \text{ MGD} \times 8.34 \text{ lb/gal} = 344 \text{ lb/day}$$

$$5.323 \quad \frac{7.1 \text{ mg/L} \times 3.24 \text{ MGD} \times 8.34 \text{ lb/gal}}{0.65} = 295 \text{ lb/day}$$

$$5.324 \quad \frac{x \text{ lb}}{(32 \text{ gal} \times 8.34 \text{ lb/gal}) + x \text{ lb}} \times 100 = 0.2$$

$$\frac{100x}{267 \text{ lb} + x} = 0.2$$

$$100x = 0.2 \times 267 \text{ lb} + x$$

$$x = 53.4 + 0.2x$$

$$100x - 0.2x = 53.4$$

$$99.8x = 53.4$$

$$x = 53.4 \text{ lb}$$

$$5.325 \quad \frac{1.9 \text{ lb}}{30 \text{ min}} = 0.063 \text{ lb/min}$$

$$0.063 \text{ lb/min} \times 1440 \text{ min/day} = 90.7 \text{ lb/day}$$

$$5.326 \quad 12 \text{ mg/L} \times 2.75 \text{ MGD} \times 8.34 \text{ lb/gal} = 275 \text{ lb/day}$$

$$\frac{275 \text{ lb/day}}{5.88 \text{ lb alum/gal solution}} = 47 \text{ gpd}$$

$$5.327 \quad (x \text{ mg/L} \times 5.115 \text{ MGD} \times 8.34 \text{ lb/gal}) = 379 \text{ lb}, \quad x = 8.8 \text{ mg/L}$$

$$5.328 \quad 12 \text{ oz.} = 0.75 \text{ lb}; \quad 2 \text{ lb}, 6 \text{ oz} = 2.38 \text{ lb}$$

$$(2.38 \text{ lb container} + \text{chemical}) - (.75 \text{ lb container}) = 1.63 \text{ lb chemical}$$

$$\frac{1.63 \text{ lb}}{30 \text{ min}} = 0.054 \text{ lb/min}$$

$$0.054 \text{ lb/min} \times 1440 \text{ min/day} = 78 \text{ lb/day}$$

$$5.329 \quad 10 \text{ mg/L} \times 3.244 \text{ MGD} \times 8.34 \text{ lb/gal}$$

$$= 600,000 \text{ mg/L} \times x \text{ MGD} \times 8.34 \text{ lb/gal}$$

$$x = 0.000054 \text{ MGD, or } 54 \text{ gpd}$$

$$5.330 \quad (32 \text{ gpm}/90 \text{ gpm}) \times 100 = 35.5\%$$

$$5.331 \quad 7.8 \text{ mg/L} = x \text{ mg/L} + 0.5 \text{ mg/L}, \quad x = 7.3 \text{ mg/L}$$

$$5.332 \quad (12/100) \times x \text{ gal} \times 9.6 \text{ lb/gal} = (0.4/100) \times 60 \text{ gal} \times 8.34 \text{ lb/gal}$$

$$x = 1.7 \text{ gal}$$

$$5.333 \quad \frac{660 \text{ mL}}{5 \text{ min}} = 132 \text{ mL/min}$$

$$\frac{132 \text{ mL/min} \times 1 \text{ gal} \times 1440 \text{ min/day}}{3785 \text{ L}} = 50.2 \text{ gpd}$$

$$12,000 \text{ mg/L} \times 0.0000502 \text{ MGD} \times 8.34 \text{ lb/gal} = 5 \text{ lb/day}$$

$$5.334 \quad \frac{0.785 \times 6 \text{ ft} \times 6 \text{ ft} \times x \text{ ft} \times 7.48 \text{ gal/ft}^3}{5 \text{ min}} = 30 \text{ gpm}, \quad x = 0.71 \text{ ft}$$

$$5.335 \quad (20 \text{ gpm}/90 \text{ gpm}) \times 100 = 22\%$$

$$5.336 \quad 9.6 \text{ mg/L} \times 4.3 \text{ MGD} \times 8.34 \text{ lb/gal} = 344 \text{ lb/day}$$

$$5.337 \quad \frac{2100 \text{ lb}}{90 \text{ lb/day}} = 23.3 \text{ days}$$

$$5.338 \quad \frac{50 \text{ gal/day} \times 3785 \text{ mL/gal} \times 1 \text{ day}}{1440 \text{ min}} = 131 \text{ mL/min}$$

$$5.339 \quad \frac{888 \text{ mL}}{5 \text{ min}} = 178 \text{ mL/min}$$

$$\frac{178 \text{ mL/min} \times 1 \text{ gal} \times 1440 \text{ min/day}}{3785 \text{ L}} = 68 \text{ gpd}$$

$$9000 \text{ mg/L} \times 0.000068 \text{ MGD} \times 8.34 \text{ lb/gal} = 5.1 \text{ lb/day polymer}$$

$$5.340 \quad 9 \text{ mg/L} \times 3.22 \text{ MGD} \times 8.34 \text{ lb/gal}$$

$$= 600,000 \text{ mg/L} \times x \text{ MGD} \times 8.34 \text{ lb/gal}$$

$$x = 0.0000483 \text{ MGD, or } 48 \text{ gpd}$$

$$\frac{48 \text{ gpd} \times 3785 \text{ mL/gal} \times 1 \text{ day}}{1440 \text{ min}} = 126 \text{ mL/min}$$

$$5.341 \quad \frac{0.785 \times 4 \text{ ft} \times 4 \text{ ft} \times 1.25 \text{ ft} \times 7.48 \text{ gal/ft}^3}{3 \text{ min}} = 39 \text{ gpm}$$

$$5.342 \quad \frac{11.1 \text{ mg/L} \times 3.115 \text{ MGD} \times 8.34 \text{ lb/gal}}{0.65} = 444 \text{ lb/day hypochlorite}$$

$$5.343 \quad \frac{[(12/100) \times 6 \text{ gal} \times 11.2 \text{ lb/gal}] + [(0.3/100) \times 22 \text{ gal} \times 8.34 \text{ lb/gal}]}{(6 \text{ gal} \times 11.2 \text{ lb/gal}) + (22 \text{ gal} \times 8.34 \text{ lb/gal})} \times 100$$

$$= \frac{8.1 \text{ lb} + 0.55 \text{ lb}}{67.2 + 183.5} \times 100 = 3.45\%$$

$$5.344 \quad 160 \text{ mg/L} \times 4.82 \text{ MGD} \times 8.34 \text{ lb/gal} = 6432 \text{ lb/day}$$

$$5.345 \quad 184 \text{ mg/L} \times 3.9 \text{ MGD} \times 8.34 \text{ lb/gal} = 5985 \text{ lb/day}$$

$$5.346 \quad 135 \text{ mg/L} \times 2.1 \text{ MGD} \times 8.34 \text{ lb/gal} = 2364 \text{ lb/day}$$

$$\frac{0.5 \text{ lb/day}}{1 \text{ lb/day}} = \frac{x \text{ lb/day}}{2364 \text{ lb/day}}$$

$$x = 0.5 \times 2364 = 1182 \text{ lb/day}$$

$$5.347 \quad 157 \text{ mg/L} \times 2.84 \text{ MGD} \times 8.34 \text{ lb/gal} = 3496 \text{ lb/day}$$

Use the y -value:

$$\frac{0.66 \text{ lb/day}}{1 \text{ lb/day}} = \frac{x \text{ lb/day}}{3496 \text{ lb/day}}$$

$$0.66 \times 3496 = x = 2307 \text{ lb/day}$$

$$5.348 \quad (0.71\text{g}/31\text{g}) \times 100 = 2.3\%$$

$$5.349 \quad 4.2 = \frac{8520 \text{ lb/day}}{x \text{ lb/day}} \times 100, \quad x = 202,857 \text{ lb/day}$$

$$5.350 \quad 5.5 = \frac{x \text{ lb/day}}{9350 \text{ gal} \times 8.34 \text{ lb/gal}} \times 100, \quad x = 4289 \text{ lb/day}$$

$$5.351 \quad 5.3 = \frac{1490 \text{ lb/day}}{x \text{ gpd} \times 8.34 \text{ lb/gal}} \times 100, \quad x = 3371 \text{ gpd}$$

$$5.352 \quad 4.4 = \frac{900 \text{ lb/day}}{x \text{ gpd} \times 8.34 \text{ lb/gal}} \times 100, \quad x = 2453 \text{ gpd}$$

$$5.353 \quad 20,100 \text{ lb/day} \times 0.41 = x \text{ lb/day} \times 0.06$$

$$x = \frac{20,100 \times 0.04}{0.06} = 13,400 \text{ lb/day}$$

$$5.354 \quad 2910 \text{ gpd} \times 8.34 \text{ lb/gal} \times 0.051 = x \text{ gpd} \times 8.64 \text{ lb/gal} \times 0.06$$

$$x = \frac{2910 \times 8.31 \times 0.051}{8.64 \times 0.06} = 2381 \text{ gpd}$$

$$5.355 \quad 12,400 \text{ lb/day} \times 0.034 = x \text{ lb/day} \times 0.054$$

$$x = \frac{12,400 \times 0.034}{0.054} = 7807 \text{ gpd}$$

$$5.356 \quad 6100 \text{ gpd} \times 8.34 \text{ lb/gal} \times 0.041 = x \text{ gpd} \times 8.6 \text{ lb/gal} \times 0.064$$

$$\frac{6100 \times 8.34 \times 0.041}{8.6 \times 0.064} = x \text{ gpd} = 3793 \text{ gpd}$$

$$5.357 \quad \frac{(70 \text{ gpm} + 82 \text{ gpm}) \times 1440 \text{ min/day}}{0.785 \times 28 \text{ ft} \times 28 \text{ ft}} = \frac{152 \text{ gpm} \times 1440 \text{ min/day}}{615 \text{ ft}^2}$$

$$= 356 \text{ gpd/ft}^2$$

$$5.358 \quad \frac{162 \text{ gpm} \times 1440 \text{ min/day}}{0.785 \times 28 \text{ ft} \times 28 \text{ ft}} = 379 \text{ gpd/ft}^2$$

$$5.359 \quad \frac{122,000 \text{ gpd} \times 8.34 \text{ lb/gal} \times (4.1/100)}{0.785 \times 44 \text{ ft} \times 44 \text{ ft}} = 27 \text{ lb/day/ft}^2$$

$$5.360 \quad \frac{60 \text{ gpm} \times 1440 \text{ min/day} \times 8.34 \text{ lb/gal} \times (3.8/100)}{0.785 \times 32 \text{ ft} \times 32 \text{ ft}} = 34 \text{ lb/day/ft}^2$$

$$5.361 \quad \frac{0.785 \times 46 \text{ ft} \times 46 \text{ ft} \times 3.8 \text{ ft} \times 7.48 \text{ gal/ft}^3}{28 \text{ gpm} \times 1440 \text{ min/day}} = 1.2 \text{ days}$$

$$5.362 \quad \frac{0.785 \times 40 \text{ ft} \times 40 \text{ ft} \times 4.3 \text{ ft} \times 7.48 \text{ gal/ft}^3}{31 \text{ gpm} \times 60 \text{ min/hr}} = 21.7$$

$$5.363 \quad 4\% = 40,000 \text{ mg/L}, \quad 0.9\% = 9000 \text{ mg/L}$$

$$\frac{31,000 \text{ mg/L}}{40,000 \text{ mg/L}} \times 100 = 78\%$$

$$5.364 \quad (2.7\%/3.3\%) \times 100 = 82\%$$

$$5.365 \quad 8.4/3.3 = 2.5$$

$$5.366 \quad 8.0/3.1 = 2.6$$

$$5.367 \quad \begin{aligned} \text{Solids in} &= 130 \text{ gpm} \times 1440 \text{ min/day} \\ &\times 8.34 \text{ lb/gal} \times (3.6/100) \\ &= 56,205 \text{ lb/day} \end{aligned}$$

$$\begin{aligned} \text{Solids out} &= 50 \text{ gpm} \times 1440 \text{ min/day} \\ &\times 8.34 \text{ lb/gal} \times (8.1/100) \\ &= 48,639 \text{ lb/day} \end{aligned}$$

$$\begin{aligned} \text{Solids out of thickener} &= (130 \text{ gpm} - 50 \text{ gpm}) \times 1440 \text{ min/day} \\ &\times 8.34 \text{ lb/gal} \times (0.059/100) \\ &= 567 \text{ lb/day} \end{aligned}$$

$$\text{Solids entering} = 56,205 \text{ lb/day}$$

$$\text{Solids leaving} = 48,639 \text{ lb/day} + 567 \text{ lb/day} = 49,206 \text{ lb/day}$$

Because more solids are entering than are leaving, the sludge blanket will increase.

$$\begin{aligned}
 5.368 \quad \text{Solids in} &= 110 \text{ gpm} \times 1440 \text{ min/day} \\
 &\times 8.34 \text{ lb/gal} \times (3.6/100) \\
 &= 47,558 \text{ lb/day} \\
 \text{Underflow solids out} &= 65 \text{ gpm} \times 1440 \text{ min/day} \\
 &\times 8.34 \text{ lb/gal} \times (7.1/100) \\
 &= 55,424 \text{ lb/day} \\
 \text{Effluent solids out} &= 110 \text{ gpm} - 65 \text{ gpm} \times 1440 \text{ min/day} \\
 &\times 8.34 \text{ lb/gal} \times (0.052/100) \\
 &= 281 \text{ lb/day} \\
 \text{Solids entering} &= 47,558 \text{ lb/day} \\
 \text{Solids out} &= 55,424 \text{ lb/day} + 281 \text{ lb/day} = 55,705 \text{ lb/day}
 \end{aligned}$$

Because more solids are leaving than are entering, the blanket will decrease.

$$\text{Decrease (lb/day)} = 55,705 \text{ lb/day} - 47,558 \text{ lb/day} = 8147 \text{ lb/day}$$

$$\begin{aligned}
 5.369 \quad \frac{9400 \text{ lb/day}}{24 \text{ hr/day}} &= 392 \text{ lb/hr} \\
 &0.785 \times 30 \text{ ft} \times 30 \text{ ft} \times 1.8 \text{ ft} \\
 \text{Fill time} &= \frac{\times 7.48 \text{ gal/ft}^3 \times 8.34 \text{ lb/gal} \times (6.6/100)}{392 \text{ lb/hr}} = 13.4 \text{ hr}
 \end{aligned}$$

$$\begin{aligned}
 5.370 \quad \frac{14,000 \text{ lb/day}}{24 \text{ hr/day}} &= 583 \text{ lb/hr} \\
 &0.785 \times 30 \text{ ft} \times 30 \text{ ft} \times 2.5 \text{ ft} \\
 \text{Fill time} &= \frac{\times 7.48 \text{ gal/ft}^3 \times 8.34 \text{ lb/gal} \times (8/100)}{583 \text{ lb/hr}} = 15.1 \text{ hr}
 \end{aligned}$$

$$\begin{aligned}
 5.371 \quad \frac{2.6 \text{ ft}}{6 \text{ ft}} &= \frac{x \text{ lb/min}}{60 \text{ lb/min}} \\
 2.6 \times 60 &= x \times 6 \\
 x &= 26 \text{ lb/min} \\
 60 \text{ lb/min} &= x \text{ lb/min withdrawal} + 26 \text{ lb/min storage} \\
 x &= 60 - 26 = 34 \text{ lb/min} \\
 x \text{ gpm} \times 8.34 \text{ lb/gal} \times (5.6/100) &= 34 \text{ lb/min} \\
 x &= \frac{34}{8.34 \times 0.056} = 73 \text{ gpm}
 \end{aligned}$$

$$5.372 \quad \frac{3.3 \text{ ft}}{7 \text{ ft}} = \frac{x \text{ lb/min}}{61 \text{ lb/min}}$$

$$3.3 \times 61 = x \times 7 \text{ ft}$$

$$x = 29 \text{ lb/min}$$

$$61 \text{ lb/min} = x \text{ lb/min withdrawal} + 29 \text{ lb/min storage}$$

$$x = 29 \text{ lb/min}$$

$$x \text{ gpm} \times 8.34 \text{ lb/gal} \times (5.6/100) = 29 \text{ lb/min}$$

$$x = \frac{29}{8.34 \times 0.056} = 63 \text{ gpm}$$

$$5.373 \quad \frac{910 \text{ gpm}}{0.785 \times 40 \text{ ft} \times 40 \text{ ft}} = 0.7 \text{ gpm/ft}^2$$

$$5.374 \quad \frac{660 \text{ gpm}}{0.785 \times 30 \text{ ft} \times 30 \text{ ft}} = 0.9 \text{ gpm/ft}^2$$

$$5.375 \quad \frac{8420 \text{ mg/L} \times 0.17 \text{ MGD} \times 8.34 \text{ lb/gal}}{0.785 \times 40 \text{ ft} \times 40 \text{ ft}} = 9.5 \text{ lb/day/ft}^2$$

$$\frac{9.5 \text{ lb/day/ft}^2}{24 \text{ hr/day}} = 0.40 \text{ lb/hr/ft}^2$$

$$5.376 \quad \frac{120 \text{ gpm} \times 60 \text{ min/hr} \times 8.34 \text{ lb/gal} \times (0.7/100)}{65 \text{ ft} \times 20 \text{ ft}} = 0.3 \text{ lb/hr/ft}^2$$

$$5.377 \quad 9 \text{ cfm} \times 60 \text{ min/hr} \times 0.075 \text{ lb/ft}^3 = 41 \text{ lb/hr}$$

$$5.378 \quad 12 \text{ cfm} \times 60 \text{ min/hr} \times 0.075 \text{ lb/ft}^3 = 54 \text{ lb/hr}$$

$$5.379 \quad 8600 \text{ mg/L} = 0.86\% \text{ solids}$$

$$\text{Air-to-Solids Ratio} = \frac{8 \text{ cfm} \times 0.075 \text{ lb/ft}^3}{85 \text{ gpm} \times 8.34 \text{ lb/gal} \times (0.86/100)} = 0.10$$

$$5.380 \quad 7800 \text{ mg/L} = 0.78\% \text{ solids}$$

$$\text{Air-to-Solids Ratio} = \frac{5 \text{ cfm} \times 0.075 \text{ lb/ft}^3}{60 \text{ gpm} \times 8.34 \text{ lb/gal} \times (0.78/100)} = 0.10$$

$$5.381 \quad (90 \text{ gpm}/85 \text{ gpm}) \times 100 = 106\%$$

$$5.382 \quad 112 = \frac{x \text{ gpm}}{70 \text{ gpm}} \times 100$$

$$x = \frac{112 \times 70}{100} = 78 \text{ gpm}$$

$$5.383 \quad (7460 \text{ mg/L} / 7700 \text{ mg/L}) \times 100 = 97\%$$

$$5.384 \quad 4.8 / 0.841 = 5.7$$

$$5.385 \quad 40 \text{ gpm} \times 60 \text{ min/hr} = 2400 \text{ gal/hr}$$

$$5.386 \quad \frac{86,400 \text{ gpd}}{24 \text{ hr/day}} = 3600 \text{ gal/hr}$$

$$5.387 \quad 70 \text{ gpm} \times 60 \text{ min/hr} \times (30 \text{ min} / 31 \text{ min}) = 4065 \text{ gal/hr}$$

$$5.388 \quad \frac{78,000 \text{ gpd}}{24 \text{ hr/day}} \times \frac{25 \text{ min}}{27 \text{ min}} = 3009 \text{ gal/hr}$$

$$5.389 \quad 7600 \text{ mg/L} = 0.76\%$$

$$\frac{110,000 \text{ gpd}}{24 \text{ hr/day}} \times 8.34 \text{ lb/gal} \times (0.76/100) = 291 \text{ lb/hr}$$

$$5.390 \quad 80 \text{ gpm} \times 60 \text{ min/hr} \times 8.34 \text{ lb/gal} \times (0.75/100) \times \frac{30 \text{ min}}{32 \text{ min}} = 281 \text{ lb/hr}$$

$$5.391 \quad \frac{32 \text{ ft}^3 \times 7.48 \text{ gal/ft}^3 \times 8.34 \text{ lb/gal} \times (6.6/100)}{70 \text{ gpm} \times 8.34 \text{ lb/gal} \times (0.74/100)} = 31 \text{ min}$$

$$5.392 \quad \frac{22 \text{ ft}^3 \times 7.48 \text{ gal/ft}^3 \times 8.34 \text{ lb/gal} \times (9/100)}{55 \text{ gpm} \times 8.34 \text{ lb/gal} \times (0.76/100)} = 35 \text{ min}$$

$$5.393 \quad (7200 \text{ mg/L} \div 8000 \text{ mg/L}) \times 100 = 90\%$$

$$5.394 \quad 0.69 / 0.92 = 75\%$$

$$5.395 \quad \frac{[16 \text{ ft}^3 \times 62.4 \text{ lb/ft}^3 \times (4.4/100)] + [4.0 \text{ ft}^3 \times 62.4 \text{ lb/ft}^3 \times (8.0/100)]}{(16 \text{ ft}^3 \times 62.4 \text{ lb}) + (4.0 \text{ ft}^3 \times 62.4 \text{ lb/ft}^3)} \times 100$$

$$= \frac{43.9 + 19.9}{998 + 250} \times 100 = 5.1\%$$

$$5.396 \quad \frac{[(12 \text{ ft}^3 \times 62.4 \text{ lb/ft}^3 \times (3.8/100))] + [(4 \text{ ft}^3 \times 62.4 \text{ lb/ft}^3 \times (8.0/100))]}{(12 \text{ ft}^3 \times 62.4 \text{ lb/ft}^3) + (4 \text{ ft}^3 \times 62.4 \text{ lb/ft}^3)} \times 100$$

$$= \frac{28.4 + 19.9}{748.8 + 249.6} \times 100 = 4.8\%$$

$$5.397 \quad 48,400 \text{ gal/day} \times 8.34 \text{ lb/gal} \times (0.8/100) = 3229 \text{ lb/day}$$

$$5.398 \quad 0.785 \times 24 \text{ ft} \times 24 \text{ ft} = 452 \text{ ft}^2$$

$$\frac{170 \text{ gpm} \times 1440 \text{ min/day}}{452 \text{ ft}^2} = 542 \text{ gpd/ft}^2$$

$$5.399 \quad 240 \text{ gpm} \times 1440 \text{ min/day} \times 8.34 \text{ lb/gal} \times (1.3/100) = 37,470 \text{ lb/day}$$

$$0.785 \times 40 \text{ ft} \times 40 \text{ ft} = 1256 \text{ ft}^2$$

$$\frac{37,470 \text{ lb/day}}{1256 \text{ ft}^2} = 30 \text{ lb/day/ft}^2$$

$$5.400 \quad \frac{690 \text{ gpm}}{0.785 \times 34 \text{ ft} \times 34 \text{ ft}} = 0.76 \text{ gpm/ft}^2$$

$$5.401 \quad 130 \text{ gpm} \times 60 \text{ min/hr} \times 8.34 \text{ lb/gal} \times (0.98/100) = 637.5 \text{ lb/hr}$$

$$0.785 \times 30 \text{ ft} \times 30 \text{ ft} = 706.5 \text{ ft}^2$$

$$\frac{637.5 \text{ lb/hr}}{706.5 \text{ ft}^2} = 0.90 \text{ lb/hr/ft}^2$$

$$5.402 \quad 184 \text{ mg/L} \times 3.5 \text{ MGD} \times 8.34 \text{ lb/gal} = 5371 \text{ lb/day}$$

$$5.403 \quad (0.66 \text{ g}/32 \text{ g}) \times 100 = 2.1\%$$

$$5.404 \quad 3750 \text{ gpd} \times 8.34 \text{ lb/gal} \times (3.9/100) = x \text{ gpd} \times 8.34 \text{ lb/gal} \times (8/100)$$

$$x = \frac{3750 \times 8.34 \times 0.039}{8.34 \times 0.08} = 1828 \text{ gpd}$$

$$5.405 \quad 9550 \text{ gal} \times 8.34 \text{ lb/gal} \times (4.9/100) = 3903 \text{ lb/day}$$

$$5.406 \quad 132 \text{ mg/L} \times 2.96 \text{ MGD} \times 8.34 \text{ lb/gal} = 3259 \text{ lb/day}$$

$$\frac{0.5 \text{ lb}}{1 \text{ lb}} = \frac{x \text{ lb/day}}{3259 \text{ lb/day}}$$

$$x = 0.5 \times 3259 = 1630 \text{ lb/day}$$

$$5.407 \quad \frac{0.785 \times 42 \text{ ft} \times 42 \text{ ft} \times 5 \text{ ft} \times 7.48 \text{ gal/ft}^3}{32 \text{ gpm} \times 60 \text{ min/hr}} = 27 \text{ hr}$$

$$5.408 \quad 7.7 \div 3.1 = 2.5$$

$$5.409 \quad \frac{7920 \text{ mg/L} \times 0.14 \text{ MGD} \times 8.34 \text{ lb/gal}}{0.785 \times 36 \text{ ft} \times 36 \text{ ft}} = 9.1 \text{ lb/day/ft}^2$$

$$\frac{9.1 \text{ lb/day/ft}^2}{24 \text{ hr/day}} = 0.38 \text{ lb/day/ft}^2$$

$$5.410 \quad (6780 \text{ mg/L} \div 7010 \text{ mg/L}) \times 100 = 97\%$$

$$5.411 \quad \frac{170 \text{ gpm} \times 1440 \text{ min/day}}{0.785 \times 30 \text{ ft} \times 30 \text{ ft}} = 346 \text{ gpd/ft}^2$$

$$5.412 \quad (3.0 \div 3.3) \times 100 = 91\%$$

$$5.413 \quad 9 \text{ cfm} \times 60 \text{ min/hr} \times 0.075 \text{ lb/ft}^3 = 41 \text{ lb/hr}$$

$$5.414 \quad 110 \text{ gpm} \times 1440 \text{ min/day} \times 8.34 \text{ lb/gal} \times 4/100 = 52,842 \text{ lb/day}$$

From underflow:

$$50 \text{ gpm} \times 1440 \text{ min/day} \times 8.34 \text{ lb/gal} \times (7.7/100) = 46,237 \text{ lb/day}$$

From effluent flow:

$$(110 \text{ gpm} - 50 \text{ gpm}) \times 1440 \text{ min/day} \times 8.34 \times (0.070/100) = 504 \text{ lb/day}$$

$$\text{In} = 52,842 \text{ lb/day}$$

$$\text{Out} = 46,237 + 504 = 46,741 \text{ lb/day}$$

Because more solids are entering the thickener than leaving, the sludge blanket will increase.

$$5.415 \quad \frac{60 \text{ gpm} \times 1440 \text{ min/day} \times 8.34 \text{ lb} \times (4.1/100)}{0.785 \times 32 \text{ ft} \times 32 \text{ ft}} = 36.7 \text{ lb/day/ft}^2$$

$$5.416 \quad \frac{190,000 \text{ gpd}}{1440 \text{ min/day}} = 132 \text{ gpm}$$

$$\frac{132 \text{ gpm}}{60 \text{ ft} \times 14 \text{ ft}} = 0.16 \text{ gpm/ft}^2$$

$$5.417 \quad \frac{9400 \text{ lb/day}}{24 \text{ hr/day}} = 392 \text{ lb/hr}$$

$$\frac{0.785 \times 26 \text{ ft} \times 26 \text{ ft} \times 2.6 \text{ ft} \times 7.48 \text{ gal/ft}^3 \times 8.34 \text{ lb/gal} \times (6.9/100)}{392 \text{ lb/hr}} = 15.2 \text{ hr}$$

$$5.418 \quad \frac{84,000 \text{ gpd}}{24 \text{ hr/day}} = 3500 \text{ gal/hr}$$

$$5.419 \quad \frac{6 \text{ cfm} \times 0.075 \text{ lb/ft}^3}{110 \text{ gpm} \times 8.34 \text{ lb/gal} \times (0.81/100)} = 0.06$$

$$5.420 \quad 112 = \frac{x \text{ gpm}}{74 \text{ gpm}} \times 100$$

$$x = \frac{112 \times 74}{100} = 83 \text{ gpm}$$

$$5.421 \quad \frac{79,000 \text{ gpd}}{24 \text{ hr/day}} \times \frac{32 \text{ min}}{34 \text{ min}} = 3098 \text{ gal/hr}$$

$$5.422 \quad \frac{2.5 \text{ ft}}{6 \text{ ft}} = \frac{x \text{ lb/min}}{48 \text{ lb/min}}$$

$$x = \frac{2.5 \times 48}{6} = 20 \text{ lb/min storage rate}$$

$$48 \text{ lb/min} = x \text{ lb/min} + 20 \text{ lb/min}$$

$$x = 28 \text{ lb/min withdrawal rate}$$

$$\text{Sludge withdrawal: } x \text{ gpm} \times 8.34 \text{ lb/gal} \times (8/100) = 20 \text{ lb/min}$$

$$x = 41 \text{ gpm}$$

$$5.423 \quad \frac{110,000 \text{ gpd} \times 8.34 \text{ lb/gal} \times (0.711/100)}{24 \text{ hr/day}} = 272 \text{ lb/hr}$$

$$5.424 \quad \frac{34 \text{ ft}^3 \times 7.48 \text{ gal/ft}^3 \times 8.34 \text{ lb/gal} \times (6.6/100)}{70 \text{ gpm} \times 8.34 \text{ lb/gal} \times (0.73/100)} = 32.5 \text{ min}$$

$$5.425 \quad \frac{100 \text{ gpm} \times 60 \text{ min/hr} \times 8.34 \text{ lb/gal} \times (0.79/100) \times 24 \text{ min}}{25.5 \text{ min}} = 372 \text{ lb/hr}$$

$$5.426 \quad \frac{[12 \text{ ft}^3 \times 62.4 \text{ lb/ft}^3 \times (3.9/100)] + [5 \text{ ft}^3 \times 62.4 \text{ lb/ft}^3 \times (7.8/100)]}{(12 \text{ ft}^3 \times 62.4 \text{ lb/ft}^3) + (5 \text{ ft}^3 \times 62.4 \text{ lb/ft}^3)} \times 100$$

$$= \frac{29.2 + 24.3}{749 + 312} \times 100 = 5\%$$

$$5.427 \quad \frac{[4240 \text{ gpd} \times 8.34 \text{ lb/gal} \times (5.9/100)] + [6810 \text{ gpd} \times 8.34 \text{ lb/gal} \times (3.5/100)]}{(4120 \text{ gpd} \times 8.34 \text{ lb/gal}) + (6810 \text{ yd} \times 8.34 \text{ lb/gal})} \times 100$$

$$= \frac{2086 \text{ lb/day} + 1988 \text{ lb/day}}{34,361 \text{ lb/day} + 56,795 \text{ lb/day}} \times 100 = 4.5\%$$

$$5.428 \quad \frac{[3510 \text{ gpd} \times 8.34 \text{ lb/gal} \times (5.2/100)] + [5210 \text{ gpd} \times 8.34 \text{ lb/gal} \times (4.1/100)]}{(3510 \text{ gpd} \times 8.34 \text{ lb/gal}) + (5210 \text{ gpd} \times 8.34 \text{ lb/gal})} \times 100$$

$$= \frac{1517 \text{ lb/day} + 1782 \text{ lb/day}}{29,273 \text{ lb/day} + 43,451 \text{ lb/day}} \times 100 = 4.5\%$$

$$5.429 \quad \frac{[3910 \text{ gpd} \times 8.34 \text{ lb/gal} \times (6.3/100)] + [6690 \text{ gpd} \times 8.34 \text{ lb/gal} \times (4.9/100)]}{(3910 \text{ gpd} \times 8.35 \text{ lb/gal}) + (6690 \text{ gpd} \times 8.34 \text{ lb/gal})} \times 100$$

$$= \frac{2054 \text{ lb/day} + 2734 \text{ lb/day}}{32,609 \text{ lb/day} + 55,795 \text{ lb/day}} \times 100 = 5.4\%$$

$$\begin{aligned}
5.430 \quad & \frac{[2510 \text{ gpd} \times 8.34 \text{ lb/gal} \times 4.3/100] + [3600 \text{ gpd} \times 8.60 \text{ lb/gal} \times 6.1/100]}{(2510 \text{ gpd} \times 8.34 \text{ lb/gal}) + (3600 \text{ gpd} \times 8.60 \text{ lb/gal})} \times 100 \\
& = \frac{900 \text{ lb/day} + 1889 \text{ lb/day}}{20,993 \text{ lb/day} + 30,960 \text{ lb/day}} \times 100 = 5.4\%
\end{aligned}$$

$$\begin{aligned}
5.431 \quad & (0.9 \text{ gal/stroke} \times 30 \text{ strokes/min}) = 27 \text{ gpm} \\
5.432 \quad & 0.785 \times 0.83 \text{ ft} \times 0.83 \text{ ft} \times 0.25 \text{ ft} \times 7.48 \text{ gal/ft}^3 = 1 \text{ gal/stroke} \\
& 1 \text{ gal/stroke} \times 30 \text{ strokes/min} = 30 \text{ gpm} \\
5.433 \quad & 0.785 \times 0.67 \text{ ft} \times 0.67 \text{ ft} \times 0.25 \text{ ft} \times 7.48 \text{ gal/ft}^3 = 0.7 \text{ gal/stroke} \\
& 0.7 \text{ gal/stroke} \times 32 \text{ strokes/min} \times 120 \text{ min/day} = 2688 \text{ gpd} \\
5.434 \quad & 0.785 \times 1 \text{ ft} \times 1 \text{ ft} \times 0.33 \text{ ft} \times 7.48 \text{ gal/ft}^3 = 1.9 \text{ gal/stroke} \\
& 1.9 \text{ gal/stroke} \times 32 \text{ strokes/min} \times 140 \text{ min/day} = 8512 \text{ gpd} \\
5.435 \quad & \frac{130 \text{ mg/L} \times 2.5 \text{ MGD} \times 8.34 \text{ lb/gal}}{0.035} = 132 \text{ gpm} \times x \text{ min/day} \times 8.34 \text{ lb/day} \\
& x = \frac{130 \times 2.5 \times 8.34}{0.035 \times 32 \times 8.34} = 290 \text{ min/day} \\
& \frac{290 \text{ min/day}}{24 \text{ hr/day}} = 12 \text{ min/hr} \\
5.436 \quad & \frac{120 \text{ mg/L} \times 1.87 \text{ MGD} \times 8.34 \text{ lb/gal}}{0.036} = 28 \text{ gpm} \times x \text{ min/day} \times 8.34 \text{ lb/day} \\
& x = \frac{120 \times 1.87 \times 8.34}{0.036 \times 28 \times 8.34} = 210 \text{ min/day} \\
& \frac{210 \text{ min/day}}{24 \text{ hr/day}} = 8.7 \text{ min/hr} \\
5.437 \quad & \frac{124 \text{ mg/L} \times 3.48 \text{ MGD} \times 8.34 \text{ lb/gal}}{4.0/100} = 38 \text{ gpm} \times x \text{ min/day} \times 8.34 \text{ lb/day} \\
& x = \frac{124 \times 3.48 \times 8.34}{0.04 \times 38 \times 8.34} = 284 \text{ min/day} \\
& \frac{284 \text{ min/day}}{24 \text{ hr/day}} = 11.8 \text{ min/hr} \\
5.438 \quad & \frac{130 \text{ mg/L} \times 1.5 \text{ MGD} \times 8.34 \text{ lb/gal}}{3.2/100} = 32 \text{ gpm} \times x \text{ min/day} \times 8.34 \text{ lb/day} \\
& x = \frac{130 \times 1.5 \times 8.34}{0.032 \times 32 \times 8.34} = 191 \text{ min/day} \\
& \frac{191 \text{ min/day}}{24 \text{ hr/day}} = 8 \text{ min/hr}
\end{aligned}$$

$$5.439 \quad 8620 \text{ lb/day} \times (66/100) = 5689 \text{ lb/day}$$

$$5.440 \quad 2810 \text{ lb/day} \times (67/100) = 1883 \text{ lb/day}$$

$$5.441 \quad 3720 \text{ gpd} \times 8.34 \text{ lb/gal} \times (5.8/100) \times (70/100) = 1260 \text{ lb/day}$$

$$5.442 \quad 5115 \text{ gpd} \times 8.34 \text{ lb/gal} \times (7/100) \times (67/100) = 2001 \text{ lb/day}$$

$$5.443 \quad 25 = \frac{x \text{ gal}}{295,200 \text{ gal}} \times 100$$

$$x = 295,200 \times (25/100) = 73,800 \text{ gal}$$

$$5.444 \quad 21 = \frac{x \text{ gal}}{0.785 \times 40 \text{ ft} \times 40 \text{ ft} \times 24 \text{ ft} \times 7.48 \text{ gal/ft}^3} \times 100$$

$$x = 0.785 \times 40 \text{ ft} \times 40 \text{ ft} \times 24 \text{ ft} \times 7.48 \text{ gal/ft}^3 \times (21/100) = 47,350 \text{ gal}$$

$$5.445 \quad \frac{62,200 \text{ gal}}{0.785 \times 50 \text{ ft} \times 50 \text{ ft} \times 20 \text{ ft} \times 7.48 \text{ gal/ft}^3} \times 100 = 21\%$$

$$5.446 \quad 20 = \frac{x \text{ gal}}{0.785 \times 40 \text{ ft} \times 40 \text{ ft} \times 18 \text{ ft} \times 7.48 \text{ gal/ft}^3} \times 100$$

$$x = 0.785 \times 40 \text{ ft} \times 40 \text{ ft} \times 18 \text{ ft} \times 7.48 \text{ gal/ft}^3 \times (20/100) = 33,822 \text{ gal}$$

$$5.447 \quad \frac{66,130 \text{ lb/day} \times (5.3/100) \times (70/100)}{120,000 \text{ gal} \times 8.34 \text{ lb} \times (6.3/100) \times (56/100)}$$

$$= \frac{2379 \text{ lb}}{35,308 \text{ lb}} = 0.07 \text{ lb/day VS added per lb VS in digester}$$

$$5.448 \quad 0.06 \text{ lb/day} = \frac{x \text{ lb/day}}{22,310 \text{ gal} \times 8.34 \text{ lb/gal} \times (6.2/100) \times (55/100)}$$

$$0.06 \times 22,310 \times 8.34 \text{ lb/gal} \times (6.2/100) \times (55/100) = x \text{ lb/day}$$

$$x = 381 \text{ lb/day}$$

$$5.449 \quad \frac{60,400 \text{ lb/day} \times (5.4/100) \times (67/100)}{96,000 \text{ gal} \times 8.34 \text{ lb/gal} \times (5/100) \times (58/100)}$$

$$= \frac{2185 \text{ lb/day}}{23,219 \text{ lb}} = 0.09 \text{ lb VS added per day per lb VS in digester}$$

$$5.450 \quad \frac{0.07 \text{ lb/day}}{\text{lb VS in Digester}} = \frac{900 \text{ gpd} \times 8.34 \text{ lb/gal} \times (5.5/100) \times (69/100)}{x \text{ gal} \times 8.34 \text{ lb/gal} \times (8.2/100) \times (52/100)}$$

$$x = \frac{900 \times 8.34 \times 0.055 \times 0.69}{0.07 \times 8.80 \times 0.082 \times 0.52} = 10,962 \text{ gal}$$

- 5.451 $\frac{86,100 \text{ lb/day} \times (5/100) \times (70/100)}{0.785 \times 50 \text{ ft} \times 50 \text{ ft} \times 22 \text{ ft}} = 0.07 \text{ lb VS/day ft}^3$
- 5.452 $\frac{28,500 \text{ gpd} \times 8.34 \text{ lb/gal} \times (5.5/100) \times (72/100)}{0.785 \times 40 \text{ ft} \times 40 \text{ ft} \times 22 \text{ ft}} = 0.341 \text{ lb/day}$
 $\frac{0.341 \text{ lb/day}}{1 \text{ ft}^3} \times 1000 = \frac{341 \text{ lb/day}}{1000 \text{ ft}^3}$
- 5.453 $\frac{36,220 \text{ gpd} \times 8.34 \text{ lb/gal} \times (5.6/100) \times (68/100)}{0.785 \times 50 \text{ ft} \times 50 \text{ ft} \times 20 \text{ ft}} = 0.293 \text{ lb/day}$
 $\frac{0.293 \text{ lb/day}}{1 \text{ ft}^3} \times 1000 = \frac{293 \text{ lb/day}}{1000 \text{ ft}^3}$
- 5.454 $\frac{16,200 \text{ gpd} \times 8.34 \text{ lb/gal} \times (5.1/100) \times (72/100)}{0.785 \times 50 \text{ ft} \times 50 \text{ ft} \times 18 \text{ ft}} = 0.14 \text{ lb/day}$
 $\frac{0.14 \text{ lb/day}}{1 \text{ ft}^3} \times 1000 = \frac{140 \text{ lb/day}}{1000 \text{ ft}^3}$
- 5.455 $\frac{116 \text{ lb/day}}{10 \text{ lb}} = \frac{2600 \text{ gpd} \times 8.34 \text{ lb/gal} \times (5.7/100) \times (66/100)}{x \text{ lb}}$
 $x = 2600 \text{ gpd} \times 8.34 \times 0.057 \times 0.66 \times 10 = 8158 \text{ lb}$
- 5.456 $\frac{1 \text{ lb/day}}{10 \text{ lb}} = \frac{6300 \text{ gpd} \times 8.34 \text{ lb/gal} \times (5/100) \times (70/100)}{x \text{ lb}}$
 $x = 6300 \times 8.34 \times 0.05 \times 0.70 \times 10 = 18,390 \text{ lb}$
- 5.457 $\frac{1 \text{ lb/day}}{10 \text{ lb}} = \frac{5200 \text{ gpd} \times 8.34 \text{ lb/gal} \times (6.5/100) \times (67/100)}{x \text{ lb}}$
 $x = 5200 \times 8.34 \times 0.065 \times 0.67 \times 10 = 18,887 \text{ lb}$
- 5.458 $\frac{1 \text{ lb/day}}{10 \text{ lb}} = \frac{3800 \text{ gpd} \times 8.34 \text{ lb/gal} \times (6/100) \times (72/100)}{x \text{ lb}}$
 $x = 3800 \times 8.34 \times 0.06 \times 0.72 \times 10 = 13,691 \text{ lb}$
- 5.459 $174 \text{ mg/L} \div 2220 \text{ mg/L} = 0.08$
- 5.460 $160 \text{ mg/L} \div 2510 \text{ mg/L} = 0.06$
- 5.461 $144 \text{ mg/L} \div 2410 \text{ mg/L} = 0.06$
- 5.462 $178 \text{ mg/L} \div 2620 \text{ mg/L} = 0.07$
- 5.463 $2280 \text{ mg/L} \times 0.244 \text{ MG} \times 8.34 \text{ lb/gal} = 4640 \text{ lb}$
- 5.464 $2010 \text{ mg/L} \times 0.200 \text{ MG} \times 8.34 \text{ lb/gal} = 3353 \text{ lb}$

$$5.465 \quad 2540 \text{ mg/L} \times 0.234 \text{ MG} \times 8.34 \text{ lb/gal} = 4898 \text{ lb}$$

$$5.466 \quad 2410 \text{ mg/L} \times 0.182 \text{ MG} \times 8.34 \text{ lb/gal} = 3658 \text{ lb}$$

$$5.467 \quad \frac{0.68 - 0.52}{0.68 - (0.68 \times 0.52)} \times 100 = \frac{0.16}{0.3264} \times 100 = 49\%$$

$$5.468 \quad \frac{0.70 - 0.54}{0.70 - (0.70 \times 0.54)} \times 100 = \frac{0.16}{0.322} \times 100 = 50\%$$

$$5.469 \quad \frac{0.70 - 0.53}{0.70 - (0.70 \times 0.53)} \times 100 = \frac{0.17}{0.329} \times 100 = 52\%$$

$$5.470 \quad \frac{0.69 - 0.54}{0.69 - (0.69 \times 0.54)} \times 100 = \frac{0.15}{0.3174} \times 100 = 47\%$$

$$5.471 \quad \frac{3800 \text{ gpd} \times 8.34 \text{ lb/gal} \times (6.3/100) \times (73/100) \times (57/100)}{36,500 \text{ ft}^3} = 0.02 \text{ lb/day/ft}^3$$

$$5.472 \quad \frac{4520 \text{ gpd} \times 8.34 \text{ lb/gal} \times (7/100) \times (69/100) \times (54/100)}{33,000 \text{ ft}^3} = 0.03 \text{ lb/day/ft}^3$$

$$5.473 \quad \frac{2600 \text{ gpd} \times 8.34 \text{ lb/gal} \times (5.6/100) \times (72/100) \times (52/100)}{0.785 \times 50 \text{ ft} \times 50 \text{ ft} \times 18 \text{ ft}} = 0.01 \text{ lb/day/ft}^3$$

$$5.474 \quad \frac{2800 \text{ gpd} \times 8.34 \text{ lb/gal} \times (6.1/100) \times (65/100) \times (56/100)}{0.785 \times 40 \text{ ft} \times 40 \text{ ft} \times 17 \text{ ft}} = 0.024 \text{ lb/day/ft}^3$$

$$\frac{0.024 \text{ lb/day}}{1 \text{ ft}^3} \times 1000 = \frac{24 \text{ lb}}{1000 \text{ ft}^3}$$

$$5.475 \quad \frac{6600 \text{ ft}^3/\text{day}}{500 \text{ lb/day}} = 13.2 \text{ ft}^3/\text{lb}$$

$$5.476 \quad \frac{19,330 \text{ ft}^3/\text{day}}{2110 \text{ lb/day} \times (59/100)} = 15.6 \text{ ft}^3/\text{lb}$$

$$5.477 \quad \frac{8710 \text{ ft}^3 \text{ gas/day}}{582 \text{ lb/day}} = 15 \text{ ft}^3/\text{lb}$$

$$5.478 \quad \frac{26,100 \text{ ft}^3 \text{ gas/day}}{3320 \text{ lb/day} \times (54/100)} = 14.6 \text{ ft}^3/\text{lb}$$

$$5.479 \quad \frac{0.785 \times 40 \text{ ft} \times 40 \text{ ft} \times 12 \text{ ft} \times 7.48 \text{ gal/ft}^3}{9100 \text{ gpd}} = 12.4 \text{ days}$$

$$5.480 \quad \frac{0.785 \times 40 \text{ ft} \times 40 \text{ ft} \times 10 \text{ ft} \times 7.48 \text{ gal/ft}^3}{8250 \text{ gpd}} = 11.4 \text{ days}$$

$$5.481 \quad \frac{80 \text{ ft} \times 25 \text{ ft} \times 12 \text{ ft} \times 7.48 \text{ gal/ft}^3}{7800 \text{ gpd}} = 23 \text{ days}$$

$$5.482 \quad 3.4\% \text{ solids} = \frac{0.785 \times 30 \text{ ft} \times 30 \text{ ft} \times 12 \text{ ft} \times 7.48 \text{ gal/ft}^3}{11,000 \text{ gpd}} = 5.8 \text{ days}$$

$$5\% \text{ solids} = \frac{0.785 \times 30 \text{ ft} \times 30 \text{ ft} \times 12 \text{ ft} \times 7.48 \text{ gal/ft}^3}{5400 \text{ gpd}} = 11.7 \text{ days}$$

Higher solids content allows greater time for digestion.

$$5.483 \quad \frac{0.06 \text{ cfm}}{1 \text{ ft}^3} = \frac{x \text{ cfm}}{90 \text{ ft} \times 30 \text{ ft} \times 12 \text{ ft}}$$

$$x = 0.06 \times 90 \times 30 \times 12 = 1944 \text{ cfm}$$

$$5.484 \quad \frac{40 \text{ cfm}}{1000 \text{ ft}^3} = \frac{x \text{ cfm}}{0.785 \times 70 \text{ ft} \times 70 \text{ ft} \times 10 \text{ ft}}$$

$$x = \frac{40 \times 0.785 \times 70 \text{ ft} \times 70 \text{ ft} \times 10 \text{ ft}}{1000} = 1539 \text{ cfm}$$

$$5.485 \quad \text{Oxygen Uptake} = \frac{5.4 \text{ mg/L} - 3.4 \text{ mg/L}}{3 \text{ min}} \times 60 \text{ min/hr}$$

$$\frac{2 \times 60}{3} = 40 \text{ mg/L/hr}$$

$$5.486 \quad \text{Oxygen Uptake} = \frac{5.7 \text{ mg/L} - 3.6 \text{ mg/L}}{3 \text{ min}} \times 60 \text{ min/hr}$$

$$\frac{2.1 \times 60}{3} = 42 \text{ mg/L/hr}$$

$$5.487 \quad 22 \text{ mg/L} \times 0.106 \text{ MG} \times 8.34 \text{ lb/gal} = 19.4 \text{ lb}$$

$$5.488 \quad 16 \text{ mg/L} \times 0.148 \text{ MG} \times 8.34 \text{ lb/gal} = 19.7 \text{ lb}$$

$$5.489 \quad \frac{64 \text{ mg}}{2 \text{ L}} \times 0.054 \text{ MG} \times 8.34 \text{ lb/gal} = 14.4 \text{ lb}$$

$$5.490 \quad 0.785 \times 60 \text{ ft} \times 60 \text{ ft} \times 14 \text{ ft} \times 7.48 \text{ gal/ft}^3 = 295,939 \text{ gal}$$

$$\frac{90 \text{ mg}}{2 \text{ L}} \times 0.296 \text{ MG} \times 8.34 \text{ lb/gal} = 111 \text{ lb}$$

$$5.491 \quad 3.6 \text{ gpm} \times 1440 \text{ min/day} \times 8.34 \text{ lb/gal} \times (5.1/100) \times 71/100 = 1566 \text{ lb/day}$$

$$5.492 \quad 0.785 \times 55 \text{ ft} \times 55 \text{ ft} \times 22 \text{ ft} = 52,242 \text{ ft}^3$$

$$47,200 \text{ gpd} \times 8.34 \text{ lb/day} \times (5.3/100) \times (71/100) = 14,813 \text{ lb/day}$$

$$\frac{14,813 \text{ lb/day}}{52,242 \text{ ft}^3} = 0.28 \text{ lb/ft}^3/\text{day}$$

$$5.493 \quad 181 \text{ mg/L} \div 2120 \text{ mg/L} = 0.085$$

$$5.494 \quad 756,000 \text{ L} = 0.756 \text{ mL}$$

$$0.756 \text{ mL} \times 1820 \text{ mg/L} = 1376 \text{ kg}$$

$$5.495 \quad \% \text{VS Reduction} = \frac{0.67 - 0.55}{0.67 - (0.67 \times 0.55)} \times 100\% = 39.8\%$$

$$5.496 \quad 2600 \text{ kg} \times (100/9.5) \times (100/66) \times (1 \text{ L}/1.14 \text{ kg})$$

$$= \frac{2600 \times 10.5 \times 1.5}{1.14} = 35,921 \text{ L}$$

$$5.497 \quad \frac{1 \text{ lb/day}}{10 \text{ lb}} = \frac{8200 \text{ gpd} \times 8.34 \text{ lb/gal} \times (5.7/100) \times (65/100)}{x \text{ lb}}$$

$$x = 8200 \times 8.34 \times 0.057 \times 0.65 \times 10 = 25,338 \text{ lb}$$

$$5.498 \quad 4400 \text{ lb/day} \times (67/100) = 2948 \text{ lb/day}$$

$$5.499 \quad \frac{12,900 \text{ gpd} \times 8.34 \text{ lb/gal} \times (5.4/100) \times (65/100)}{\frac{0.785 \times 60 \text{ ft} \times 60 \text{ ft} \times 20 \text{ ft}}{1000}} = \frac{67 \text{ lb/day}}{1000 \text{ ft}^3}$$

$$5.500 \quad \frac{[4040 \text{ gpd} \times 8.34 \text{ lb/gal} \times (5.4/100)] + [5820 \text{ gpd} \times 8.34 \text{ lb/gal} \times (3.3/100)]}{(4040 \text{ gpd} \times 8.34 \text{ lb/gal}) + (5820 \text{ gpd} \times 8.34 \text{ lb/gal})} \times 100$$

$$= \frac{1819 \text{ lb/day} + 1602 \text{ lb/day}}{33,694 \text{ lb/day} + 45,339 \text{ lb/day}} \times 100 = 4.3\%$$

$$5.501 \quad 0.785 \times 0.67 \text{ ft} \times 0.67 \text{ ft} \times 0.5 \text{ ft} \times 7.48 \text{ gal/ft}^3 = 1.3 \text{ gal/stroke}$$

$$1.3 \text{ gal/stroke} \times 3500 \text{ strokes/day} = 4550 \text{ gpd}$$

$$5.502 \quad \frac{88,200 \text{ gal}}{0.785 \times 60 \text{ ft} \times 60 \text{ ft} \times 24 \text{ ft} \times 7.48 \text{ gal/ft}^3} \times 100 = 17.4\%$$

$$5.503 \quad \frac{3800 \text{ gpd} \times 8.34 \text{ lb/gal} \times (4.1/100) \times (70/100) \times (54/100)}{36,000 \text{ ft}^3} = 0.01 \text{ lb/day/ft}^3$$

- 5.504 $156 \text{ mg/L} \div 2310 \text{ mg/L} = 0.07$
- 5.505 $2240 \text{ mg/L} \times 0.24 \text{ MG} \times 8.34 \text{ lb/gal} = 4484 \text{ lb lime}$
- 5.506 $24 = \frac{x \text{ gal}}{0.785 \times 50 \text{ ft} \times 50 \text{ ft} \times 22 \text{ ft} \times 7.48 \text{ gal/ft}^3} \times 100$
 $x = \frac{24 \times 0.785 \times 50 \times 50 \times 22 \times 7.48}{100} = 77,508 \text{ gal}$
- 5.507 $4310 \text{ gpd} \times 8.34 \text{ lb/gal} \times 5.3/100 \times (72/100) = 1372 \text{ lb/day}$
- 5.508 $\frac{[2940 \text{ gpd} \times 8.34 \text{ lb/gal} \times (5.9/100)] + [4720 \text{ gpd} \times 8.34 \text{ lb/gal} \times (3.8/100)]}{(2940 \text{ gpd} \times 8.34 \text{ lb/gal}) + (4720 \text{ gpd} \times 8.34 \text{ lb/gal})} \times 100$
 $= \frac{1447 \text{ lb/day} + 1496 \text{ lb/day}}{24,520 \text{ lb/day} + 39,365 \text{ lb/day}} \times 100 = 4.6\%$
- 5.509 $150 \text{ mg/L} \div 2470 \text{ mg/L} = 0.06$
- 5.510 $\frac{42,500 \text{ lb/day} \times (4/100) \times (60/100)}{94,000 \text{ gal} \times 8.34 \text{ lb/gal} \times (6/100) \times (55/100)} = 0.04 \text{ lb/day}$
- 5.511 $0.785 \times 0.75 \text{ ft} \times 0.75 \text{ ft} \times 0.42 \text{ ft} \times 7.48 \text{ gal/ft}^3 = 1.4 \text{ gal/stroke}$
 $1.4 \text{ gal/stroke} \times 30 \text{ strokes/min} = 42 \text{ gpm}$
- 5.512 $\frac{19,200 \text{ gpd} \times 8.34 \text{ lb/gal} \times (5/100) \times (66/100)}{\frac{0.785 \times 40 \text{ ft} \times 40 \text{ ft} \times 21 \text{ ft}}{1000}} = \frac{200 \text{ lb/day}}{1000 \text{ ft}^3}$
- 5.513 $2200 \text{ mg/L} \times 0.3 \text{ MG} \times 8.34 \text{ lb/gal} = 5504 \text{ lb}$
- 5.514 $\frac{6760 \text{ ft}^3}{580 \text{ lb/day}} = 11.7 \text{ ft}^3/\text{lb}$
- 5.515 $\frac{0.67 - 0.52}{0.67 - (0.67 \times 0.52)} \times 100 = 47\%$
- 5.516 $\frac{0.09 \text{ lb/day}}{1 \text{ lb}} = \frac{1230 \text{ gpd} \times 8.34 \text{ lb/gal} \times (4.1/100) \times (66/100)}{x \text{ gal} \times 8.5 \text{ lb/gal} \times (7.5/100) \times (55/100)}$
 $x = \frac{1230 \times 8.34 \times 0.041 \times 0.66}{0.09 \times 8.5 \times 0.075 \times 0.55} = 8675 \text{ gal}$
- 5.517 $\frac{0.70 - 0.56}{0.70 - (0.70 \times 0.56)} \times 100 = 45\%$

$$5.518 \quad \frac{0.785 \times 60 \text{ ft} \times 60 \text{ ft} \times 12 \text{ ft} \times 7.48 \text{ gal/ft}^3}{9350 \text{ gpd}} = 27.1 \text{ days}$$

$$5.519 \quad \frac{22,400 \text{ ft}^3/\text{gal/day}}{2610 \text{ lb/day} \times (56/100)} = 15 \text{ ft}^3/\text{lb}$$

$$5.520 \quad \frac{3200 \text{ gpd} \times 8.34 \text{ lb/gal} \times (6.4/100) \times (68/100) \times (55/100)}{\frac{0.785 \times 50 \text{ ft} \times 50 \text{ ft} \times 22 \text{ ft}}{1000}} = \frac{14.8 \text{ lb/day}}{1000 \text{ ft}^3}$$

$$5.521 \quad \frac{0.05 \text{ cfm}}{1 \text{ ft}^3} = \frac{x \text{ cfm}}{80 \text{ ft} \times 20 \text{ ft} \times 12 \text{ ft}}$$

$$x = 0.05 \times 80 \text{ ft} \times 20 \text{ ft} \times 12 \text{ ft} = 960 \text{ cfm}$$

$$5.522 \quad 22 \text{ mg/L} \times 0.12 \text{ MG} \times 8.34 \text{ lb/gal} = 22 \text{ lb}$$

$$5.523 \quad \frac{6.0 \text{ mg/L} - 3.8 \text{ mg/L}}{3 \text{ min}} \times 60 \text{ min/hr} = 44 \text{ mg/L/hr}$$

$$5.524 \quad \frac{119 \text{ mg/L} \times 2.2 \text{ MGD} \times 8.34 \text{ lb/gal}}{3.0/100} = 25 \text{ gpm} \times 8.34 \text{ lb/gal} \times x \text{ min/day}$$

$$x = \frac{119 \times 2.2 \times 8.34}{0.030 \times 25 \times 8.34} = 347 \text{ min/day}$$

$$\text{Pump Operating Time} = \frac{347 \text{ min/day}}{24 \text{ hr/day}} = 14.5 \text{ min/hr}$$

$$5.525 \quad 2.6\% \text{ Solids} = \frac{0.785 \times 32 \text{ ft} \times 32 \text{ ft} \times 24 \text{ ft} \times 7.48 \text{ gal/ft}^3}{12,000 \text{ gpd}} = 12 \text{ days}$$

$$4.6\% \text{ Solids} = \frac{0.785 \times 32 \text{ ft} \times 32 \text{ ft} \times 24 \text{ ft} \times 7.48 \text{ gal/ft}^3}{5400 \text{ gpd}} = 27 \text{ days}$$

$$5.526 \quad \frac{(1100 \text{ gal/3 hr}) \times 8.34 \text{ lb/gal} \times (3.8/100)}{140 \text{ ft}^2} = 0.83 \text{ lb/hr/ft}^2$$

$$5.527 \quad \frac{(820 \text{ gal/2 hr}) \times 8.34 \text{ lb/gal} \times (5/100)}{160 \text{ ft}^2} = 1.1 \text{ lb/hr/ft}^2$$

$$5.528 \quad 0.80 \text{ lb/hr/ft}^2 \times \frac{2 \text{ hr}}{2 \text{ hr} + 20 \text{ min}} = 0.80 \text{ lb/hr/ft}^2 \times \frac{2 \text{ hr}}{2.33 \text{ hr}} = 0.7 \text{ lb/hr/ft}^2$$

$$5.529 \quad \frac{(680 \text{ gal/2 hr}) \times 8.34 \text{ lb/gal} \times (3.9/100)}{130 \text{ ft}^2} = 0.85 \text{ lb/hr/ft}^2$$

$$\frac{0.85 \text{ lb/hr/ft}^2 \times 2 \text{ hr}}{2.33 \text{ hr}} = 0.7 \text{ lb/hr/ft}^2$$

$$5.530 \quad \frac{140 \text{ gpm}}{6 \text{ ft}} = 23 \text{ gpm/ft}$$

$$5.531 \quad \frac{21,300 \text{ lb/day}}{12 \text{ hr/day}} = 1775 \text{ lb/hr}$$

$$5.532 \quad 1800 \text{ lb/hr} = \frac{23,100 \text{ lb/day}}{x \text{ hr/day}}$$

$$x = \frac{23,100 \text{ lb/day}}{1800 \text{ lb/hr}} = 13 \text{ hr/day}$$

$$5.533 \quad 160 \text{ gpm} \times 60 \text{ min/hr} \times 8.34 \text{ lb/gal} \times (4.4/100) = 3523 \text{ lb/hr}$$

$$5.534 \quad 0.7\% = 7000 \text{ mg/L}$$

$$\frac{4 \text{ gpm} \times 1440 \text{ min/day}}{1,000,000} = 0.00576 \text{ MGD}$$

$$\frac{7000 \text{ mg/L} \times 0.00576 \text{ MGD} \times 8.34 \text{ lb/gal}}{24 \text{ hr/day}} = 14 \text{ lb/hr}$$

$$5.535 \quad \frac{80 \text{ gpm} \times 60 \text{ min/hr} \times 8.34 \text{ lb/gal} \times (5.1/100)}{320 \text{ ft}^2} = 6.4 \text{ lb/hr/ft}^2$$

$$5.536 \quad \frac{6810 \text{ lb/hr} \times (31/100)}{320 \text{ ft}^2} = 6.6 \text{ lb/hr/ft}^2$$

$$5.537 \quad 3.3 \text{ lb/hr/ft}^2 = \frac{5400 \text{ lb/day}}{x \text{ hr/day}} \times (90/100)$$

$$\frac{5400 \text{ lb/day}}{230 \text{ ft}^2}$$

$$3.3 \text{ lb/hr/ft}^2 = \frac{5400 \text{ lb/day}}{x \text{ hr/day}} \times 1/230 \text{ ft}^2 \times (90/100)$$

$$x = \frac{5400 \times 1 \times 90}{3.3 \times 230 \times 100} = 6.4 \text{ hr/day}$$

$$5.538 \quad \frac{18,310 \text{ lb/day}}{10 \text{ hr/day}} \times (91/100) = \frac{1831 \text{ lb/hr}}{265 \text{ ft}^2} \times (91/100) = 6.3 \text{ lb/hr/ft}^2$$

$$5.539 \quad \frac{18,400 \text{ lb/hr} \times (20/100)}{85,230 \text{ lb/hr} \times (5.9/100)} \times 100 = \frac{3680 \text{ lb/hr}}{5029 \text{ lb/hr}} \times 100 = 73\%$$

$$5.540 \quad 210 \text{ ft} \times 22 \text{ ft} \times 0.67 \text{ ft} \times 7.48 \text{ gal/ft}^3 = 23,154 \text{ gal}$$

$$5.541 \quad 240 \text{ ft} \times 26 \text{ ft} \times 0.67 \text{ ft} \times 7.48 \text{ gal/ft}^3 = 31,272 \text{ gal}$$

$$5.542 \quad \frac{\left[\frac{168,000 \text{ lb} \times 365 \text{ days/yr} \times (4.6/100)}{21 \text{ days}} \right]}{190 \text{ ft} \times 20 \text{ ft}} = 35.3 \text{ lb/yr/ft}^2$$

$$5.543 \quad 220 \text{ ft} \times 30 \text{ ft} \times 0.75 \times 7.48 \text{ gal/ft}^3 \times 8.34 \text{ lb/gal} = 308,797 \text{ lb}$$

$$\frac{\left[\frac{308,797 \text{ lb} \times 365 \text{ days/yr} \times (0.039/100)}{25 \text{ days}} \right]}{220 \text{ ft} \times 30 \text{ ft}} = 26.6 \text{ lb/yr/ft}^2$$

$$5.544 \quad 0.785 \times 50 \text{ ft} \times 50 \text{ ft} \times 2.4 \text{ ft} = 4710 \text{ ft}^3$$

$$5.545 \quad 0.785 \times 50 \text{ ft} \times 50 \text{ ft} \times 1.17 \text{ ft} = 70 \text{ ft} \times 40 \text{ ft} \times x \text{ ft}, \quad x = 0.82 \text{ ft}$$

$$5.546 \quad \text{Sludge moisture} = \frac{\left[\frac{4700 \text{ lb/day} \times (79/100)}{4700 \text{ lb/day} + 3800 \text{ lb/day}} \right] + \left[\frac{3800 \text{ lb/day} \times (26/100)}{4700 \text{ lb/day} + 3800 \text{ lb/day}} \right]}{100} \times 100$$

$$= \frac{3713 + 988}{8500} \times 100 = 55\%$$

$$5.547 \quad \text{Sludge moisture} = 83\%$$

$$42 = \frac{\left[\frac{4800 \text{ lb/day} \times (83/100)}{4800 \text{ lb/day} + x \text{ lb/day}} \right] + \left[\frac{x \text{ lb/day} \times (27/100)}{4800 \text{ lb/day} + x \text{ lb/day}} \right]}{100} \times 100$$

$$\frac{42}{100} = \frac{3984 \text{ lb/day} + (x \text{ lb/day} \times 0.27)}{4800 \text{ lb/day} + x \text{ lb/day}}$$

$$0.42 \times (4800 + x) = 3984 + 0.27x$$

$$2016 + 0.42x = 3984 + 0.27x$$

$$0.42x - 0.27x = 3984 - 2016$$

$$0.15x = 1968$$

$$x = 13,120 \text{ lb/day}$$

$$5.548 \quad \frac{\left[\frac{7.4 \text{ yd}^3 \times 1710 \text{ lb/yd}^3 \times (19/100)}{7.4 \text{ yd}^3 \times 1710 \text{ lb/yd}^3 + (7.4 \text{ yd}^3 \times 3 \times 760 \text{ lb/yd}^3)} \right] + \left[\frac{7.4 \text{ yd}^3 \times 3 \times 760 \text{ lb/yd}^3 \times (54/100)}{7.4 \text{ yd}^3 \times 1710 \text{ lb/yd}^3 + (7.4 \text{ yd}^3 \times 3 \times 760 \text{ lb/yd}^3)} \right]}{100} \times 100$$

$$= \frac{2404 + 9111}{12,654 + 16,872} \times 100 = \frac{11,515}{29,526} \times 100 = 39\%$$

$$5.549 \quad 21 \text{ days} = \frac{8200 \text{ yd}^3}{x \text{ lb/day}} = \frac{8200 \text{ yd}^3 \times 1000 \text{ lb/yd}^3}{1000 \text{ lb/yd}^3 \times x \text{ lb/day}}$$

$$x = \frac{8200 \times 1000}{21} = 390,476 \text{ lb/day}$$

$$\begin{aligned}
 5.550 \quad & \frac{[12 \text{ yd}^3 \times 1720 \text{ lb/yd}^3 \times (16/100)] + [12 \text{ yd}^3 \times 3 \times 820 \text{ lb/yd}^3 \times (55/100)]}{(12 \text{ yd}^3 \times 1720 \text{ lb/yd}^3) + (12 \text{ yd}^3 \times 3 \times 820 \text{ lb/yd}^3)} \times 100 \\
 & = \frac{3302 \text{ lb} + 16,236 \text{ lb}}{20,640 \text{ lb} + 29,520 \text{ lb}} \times 100 = \frac{19,538 \text{ lb}}{50,160 \text{ lb}} \times 100 = 39\%
 \end{aligned}$$

$$5.551 \quad 21 \text{ days} = \frac{7810 \text{ yd}^3 \times 1100 \text{ lb/yd}^3}{\left[\frac{x \text{ lb/day}}{0.19} + \left(\frac{x \text{ lb/day}}{0.19} \times \frac{3}{1} \times \frac{780 \text{ lb/yd}^3}{1720 \text{ lb/yd}^3} \right) \right]}$$

$$21 = \frac{7,810,000}{\left(\frac{x}{0.19 + 7.16x} \right)}$$

$$21 = \frac{7,810,000}{\left(\frac{1}{0.19x} + 7.16x \right)}$$

$$21 = \frac{7,810,000}{5.26x + 7.16x}$$

$$21 = \frac{7,810,000}{12.42x}$$

$$12.42x = \frac{7,810,000}{21}$$

$$x = \frac{7,810,000}{21 \times 12.42} = 29,923 \text{ lb/day}$$

$$5.552 \quad 220 \text{ ft} \times 24 \text{ ft} \times 0.83 \times 7.48 \text{ gal/ft}^3 = 32,780 \text{ gal}$$

$$32,780 \text{ gal} \times (3.3/100) \times (8.34 \text{ lb/gal}) = 9022 \text{ lb}$$

$$\frac{9022 \text{ lb}}{22 \text{ days}} = 410.09 \text{ lb/day}$$

$$410.09 \text{ lb/day} \times 365 \text{ days/yr} = 149,683 \text{ lb/yr}$$

$$\frac{149,683 \text{ lb/yr}}{220 \text{ ft} \times 24 \text{ ft}} = 28.3 \text{ lb/yr/ft}^2$$

$$5.553 \quad \frac{0.20 \text{ MG/day} \times 1,000,000 \text{ gal}}{1440 \text{ min/day}} = 139 \text{ gpm}$$

$$5.554 \quad 960 \text{ gal} \times (94.2/100) \times 8.34 \text{ lb/gal} = 336.27 \text{ lb}$$

$$\frac{336.27 \text{ lb}}{140 \text{ min}} \times 60 \text{ min/hr} = 144 \text{ lb/hr}$$

$$\frac{144 \text{ lb/hr}}{150 \text{ ft}^2} = 0.96 \text{ lb/hr/ft}^2$$

$$5.555 \quad \text{Area} = 3.14 \times 9.6 \text{ ft} \times 10 \text{ ft} = 301 \text{ ft}^2$$

$$36 \text{ gpm} \times 60 \text{ min/hr} \times 8.34 \text{ lb/gal} \times 12/100 = 2162 \text{ lb/hr}$$

$$\frac{2162 \text{ lb/hr}}{301 \text{ ft}^2} = 7.2 \text{ lb/hr/ft}^2$$

$$5.556 \quad 3020 \text{ lb/hr} \times (40/100) = 1208 \text{ lb/hr}$$

$$24 \text{ gal/min} \times 60 \text{ min/hr} \times 8.50 \text{ lb/gal} \times (11/100) = 1346 \text{ lb/hr}$$

$$\% \text{ Recovery} = \frac{1208 \text{ lb/hr}}{1346 \text{ lb/hr}} \times 100 = 90\%$$

$$5.557 \quad \frac{25,200 \text{ lb/day}}{12 \text{ hr/day}} = 2100 \text{ lb/hr}$$

$$5.558 \quad \frac{800 \text{ gal/2 hr} \times 8.34 \text{ lb/gal} \times (4.1/100)}{141 \text{ ft}^2} = 0.97 \text{ lb/hr/ft}^2$$

$$5.559 \quad 170 \text{ gpm} \times 60 \text{ min/hr} \times 8.34 \text{ lb/gal} \times (5/100) = 4253 \text{ lb/hr}$$

$$\frac{4253 \text{ lb/hr}}{2000 \text{ lb/ton}} = 2.1 \text{ tons/hr}$$

$$\frac{2.8 \text{ gpm} \times 1440 \text{ min/day}}{1,000,000} = 0.0040 \text{ MGD}$$

$$9000 \text{ mg/L} \times 0.0040 \text{ MGD} \times 8.34 \text{ lb/gal} = 300 \text{ lb/day}$$

$$\frac{300 \text{ lb/day}}{24 \text{ hr/day}} = 12.5 \text{ lb/hr}$$

$$\frac{12.5 \text{ lb/hr}}{2.1 \text{ ton/hr}} = 5.95 \text{ lb/ton}$$

$$5.560 \quad \frac{0.8 \text{ lb/hr/ft}^2 \times 2 \text{ hr}}{2 \text{ hr} + 20 \text{ min}} = \frac{0.8 \text{ lb/hr/ft}^2 \times 2 \text{ hr}}{2.33 \text{ hr}} = 0.69 \text{ lb/hr/ft}^2$$

$$5.561 \quad 24,300 \text{ mg/L} - 740 \text{ mg/L} = 23,560 \text{ mg/L}$$

$$5.562 \quad \frac{80 \text{ gpm} \times 60 \text{ min/hr} \times 8.34 \text{ lb/gal} \times (5.5/100)}{320 \text{ ft}^2} = 6.9 \text{ lb/hr/ft}^2$$

$$5.563 \quad \frac{7500 \text{ lb/hr} \times (26/100)}{320 \text{ ft}^2} = 6.1 \text{ lb/hr/ft}^2$$

$$5.564 \quad 1800 \text{ lb/hr} = \frac{28,300 \text{ lb/day}}{x \text{ hr/day}}$$

$$x = \frac{28,300 \text{ lb/day}}{1800 \text{ lb/hr}} = 15.7 \text{ hr/day}$$

$$5.565 \quad 3.1 = \frac{\left(\frac{5700 \text{ lb/day}}{x \text{ hr/day}} \right)}{280 \text{ ft}^2} \times (92/100)$$

$$3.1 = \frac{5700 \text{ lb/day}}{x \text{ hr/day}} \times \frac{1}{280 \text{ ft}^2} \times \frac{92}{100}$$

$$x = \frac{5700 \times 1 \times 92}{3.1 \times 280 \times 100} = 6 \text{ hr/day}$$

$$5.566 \quad 220 \text{ ft} \times 30 \text{ ft} \times 0.75 \text{ in.} \times 7.48 \text{ gal/ft}^3 = 37,026 \text{ gal}$$

$$5.567 \quad \frac{14,300 \text{ lb/hr} \times (28/100)}{91,000 \text{ lb/hr} \times (5.3/100)} \times 100$$

$$\frac{4004 \text{ lb/hr}}{4823 \text{ lb/hr}} \times 100 = 83\%$$

$$5.568 \quad 8 \text{ in.} = 0.67 \text{ ft}$$

$$200 \text{ ft} \times 25 \text{ ft} \times 0.67 \text{ ft} \times 7.48 \text{ gal/ft}^3 \times 8.34 \text{ lb/gal} = 208,984 \text{ lb sludge}$$

$$\frac{\frac{208,984 \text{ lb}}{200 \text{ ft}} \times \frac{365 \text{ days}}{\text{yr}} \times (5.1 / 100)}{200 \text{ ft} \times 25 \text{ ft}} = \frac{194,512 \text{ lb/yr}}{5000 \text{ ft}^2} = 39 \text{ lb/yr/ft}^2$$

$$5.569 \quad \frac{0.785 \times 40 \text{ ft} \times 40 \text{ ft} \times 1}{190 \text{ ft} \times 30 \text{ ft}} = 0.22 \text{ ft}$$

$$5.570 \quad \text{Moisture content} = 75\%$$

$$55 = \frac{[6800 \text{ lb/day} \times (75/100)] + [x \text{ lb/day} \times (36/100)]}{6800 \text{ lb/day} + x \text{ lb/day}} \times 100$$

$$\frac{55}{100} = \frac{5100 \text{ lb/day} + (x \text{ lb/day} \times 0.36)}{6800 \text{ lb/day} + x \text{ lb/day}}$$

$$0.55 \times (6800 + x) = 5100 + 0.36x$$

$$3740 + 0.55x = 5100 + 0.36x$$

$$0.55x - 0.36x = 5100 - 3740$$

$$0.19x = 1360$$

$$x = 7158 \text{ lb/day}$$

$$5.571 \quad \frac{[7.0 \text{ yd}^3 \times 1710 \text{ lb/yd}^3 \times (16/100)] + [7.0 \text{ yd}^3 \times 3 \times 780 \text{ lb/yd}^3 \times (51/100)]}{(7.0 \text{ yd}^3 \times 1710 \text{ lb/yd}^3) + (7.0 \text{ yd}^3 \times 3 \times 780 \text{ lb/yd}^3)} \times 100$$

$$\frac{1915 \text{ lb} + 8354 \text{ lb}}{11,970 \text{ lb} + 16,380 \text{ lb}} \times 100 = \frac{10,269 \text{ lb}}{28,350 \text{ lb}} \times 100 = 36.2\%$$

$$5.572 \quad 26 \text{ days} = \frac{6350 \text{ yd}^3}{\left(\frac{x \text{ lb/day}}{980 \text{ lb/ft}^3} \right)}$$

$$26 \text{ days} = \frac{6350 \text{ yd}^3 \times 980 \text{ lb/yd}^3}{x \text{ lb/day}}$$

$$x = \frac{6350 \text{ yd}^3 \times 980 \text{ lb/yd}^3}{26 \text{ days}} = 239,346 \text{ lb/day}$$

$$\frac{239,346 \text{ lb/day}}{2000 \text{ lb/ton}} = 120 \text{ ton/day}$$

$$5.573 \quad 24 \text{ days} = \frac{9000 \text{ yd}^3 \times 1100 \text{ lb/yd}^3}{\frac{x \text{ lb/day}}{0.18} + \left(\frac{x \text{ lb/day}}{0.18} \times \frac{3.3}{1} \times \frac{800 \text{ lb/yd}^3}{1710 \text{ lb/yd}^3} \right)}$$

$$24 = \frac{9,900,000}{\frac{1}{0.18}x + 8.58x}$$

$$24 = \frac{9,900,000}{5.56x + 8.58x}$$

$$24 = \frac{9,900,000}{14.14x}$$

$$14.14x = \frac{9,900,000}{24}$$

$$x = \frac{9,900,000}{24 \times 14.14} = 29,204 \text{ lb}$$

CHAPTER 6 ANSWERS

- 6.1 Licensed operator and the responsible official
- 6.2 The amount of organic material in a sample that can be oxidized by a strong oxidizing agent
- 6.3 Prevent disease, protect aquatic organisms, protect water quality
- 6.4 Dissolved and suspended
- 6.5 Organic—matter that is made up mainly of carbon, hydrogen, and oxygen and will decompose into mainly carbon dioxide and water at 550°C; inorganic—materials, such as salt, ferric chloride, iron, sand, and gravel
- 6.6 Algae, bacteria, protozoa, rotifers, virus
- 6.7 Carbon dioxide, water, more organics, stable solids
- 6.8 Toxic matter, inorganic dissolved solids, pathogenic organisms
- 6.9 Raw effluent

- 6.10 From body wastes of humans who have disease
- 6.11 Disease-causing
- 6.12 Domestic waste
- 6.13 Industrial waste
- 6.14 4.4%
- 6.15 2.3 ft
- 6.16 $5250 \text{ gal} \times 8.34 \text{ lb/gal} = 43,785 \text{ lb}$
- 6.17 14,362 gal
- 6.18 850.7 lb/day
- 6.19 686 kg/day
- 6.20 0.121 MGD
- 6.21 8,477 people
- 6.22 9.41 lb/gal
- 6.23 Cutter may be sharpened and/or replaced when needed; cutter alignment must be adjusted as needed
- 6.24 Grit is heavy inorganic matter, such as sand, gravel, metal filings, egg shells, and coffee grounds
- 6.25 0.7 fps
- 6.26 Large amount of organic matter in the gut; the aeration rate must be increased to prevent settling of the organic solids
- 6.27 To remove settleable and floatable solids
- 6.28 To remove the settleable solids formed by the biological activity
- 6.29 7962 gpd/ft
- 6.30 Stabilization pond, oxidation pond, polishing pond
- 6.31 Settling, anaerobic digestion of settled solids, aerobic/anaerobic decomposition of dissolved and colloidal organic solids by bacteria producing stable solids and carbon dioxide, photosynthesis
- 6.32 Products of oxygenation by algae; summer effluent is high in solids (algae) and low in BOD, and winter effluent is low in solids and high in BOD
- 6.33 Eliminates wide diurnal and seasonal variation in pond dissolved oxygen
- 6.34 Standard, high-rate, roughing
- 6.35 Increase waste rate
- 6.36 Decrease, decrease, decrease, increase, increase
- 6.37 10 containers
- 6.38 88 days
- 6.39 103 cylinders; \$2823.49

- 6.40 4716 lb/day
- 6.41 21.5 lb
- 6.42 27 days
- 6.43 64.1%
- 6.44 National Pollutant Discharge Elimination System
- 6.45 By increasing the primary sludge pumping rate or by adding dilution water
- 6.46 7.0 pH
- 6.47 Because the microorganisms have been killed or they are absent
- 6.48 The time to do the test, 3 hr vs. 5 days
- 6.49 Dark, greasy
- 6.50 Increases
- 6.51 Temperature, pH, toxicity, waste rate, aeration tank configuration
- 6.52 Can function with or without dissolved oxygen; prefer dissolved oxygen but can use chemically combined oxygen such as sulfate or nitrate
- 6.53 Organic
- 6.54 Living organisms
- 6.55 Final
- 6.56 Colloidal
- 6.57 Not possible
- 6.58 Aerobic, facultative
- 6.59 Different
- 6.60 Reduced
- 6.61 Temperature
- 6.62 BOD
- 6.63 F/M
- 6.64 Secondary clarifier weirs
- 6.65 To separate and return biosolids to the aeration tank
- 6.66 Declining
- 6.67 1.5 and 2.5 mg/L
- 6.68 Increased MLVSS concentration
- 6.69 Decreased waste rate
- 6.70 Decreased MCRT
- 6.71 Concentration of aeration influent solids
- 6.72 Compete mix is more resistant to shock loads

- 6.73 Decrease the grit channel aeration rate
- 6.74 Increase
- 6.75 Floor level
- 6.76 \$22.77
- 6.77 Anoxic
- 6.78 C:N:P
- 6.79 Secondary
- 6.80 Are not
- 6.81 2 ft/s
- 6.82 Lower
- 6.83 Chlorine residual
- 6.84 2 hr
- 6.85 0.1
- 6.86 800 gal/ft²/day
- 6.87 Monochloramine
- 6.88 0.2 to 0.5
- 6.89 Nitrogen
- 6.90 Decrease explosive hazard, decrease odor release, maintain temperature, collect gas
- 6.91 Algae
- 6.92 Dissolved solids
- 6.93 0.0005 ppm
- 6.94 854.9 gpm
- 6.95 Decrease the grit channel aeration rate

FORMULAE

AREA (FT²)

Rectangular Tank

$$A = L \times W$$

Circular Tank

$$A = \pi r^2 \text{ or } A = 0.785 D^2$$

VOLUME (FT³)

Rectangular Tank

$$V = L \times W \times H$$

Circular Tank

$$V = \pi r^2 \times H \text{ or } 0.785 D^2 \times H$$

FLOW (CFS)

$$\text{Gallons per day (gpd)} = \text{Gallons per minute (gpm)} \times 1440 \text{ min/day}$$

$$\text{Gallons per day (gpd)} = \text{Gallons per hour} \times 24 \text{ hr/day}$$

$$\text{Million gallons per day (MGD)} = (\text{Gallons per day})/1,000,000$$

DOSE

$$\text{Pounds (lb)} = \text{ppm} \times \text{MG} \times 8.34 \text{ lb/gal}$$

$$\text{Parts per million (ppm)} = \text{lb}/(\text{MG} \times 8.34 \text{ lb/gal})$$

EFFICIENCY (% REMOVAL)

$$\text{Efficiency} = \frac{(\text{Influent} - \text{Effluent})}{\text{Influent}} \times 100$$

WEIR LOADING (OVERFLOW RATE)

$$\text{Weir Loading} = \frac{\text{Total gallons per day}}{\text{Length of weir}}$$

SURFACE SETTLING RATE

$$\text{Surface Settling Rate} = \frac{\text{Total gallons per day}}{\text{Surface area of tank}}$$

INDEX

10% rule, 16–17

A

abiotic factors, 13, 14, 56
 stream ecosystem, 23–24
acids, 76–77
activated carbon, 206, 216
activated sludge aeration basins, 215
activated sludge process, 204, 212
 anoxic, 205
actual size, 117
actuator, 133, 187
adaptation, 3, 9, 21, 27, 32, 33, 36–38, 39,
 40, 42, 46, 50
adsorption, 208
 carbon, 206–207
advanced wastewater treatment, 197–216
aeration basins, 213, 214, 215
aeration tank, 203
aerobic biological selectors, 215
aestivation, 38
agroecosystems, 11–12
air conditioning, 156–158
 drawings, 158
 schematics, 188–189, 191
air conditioning and refrigeration (AC&R),
 84, 153, 162, 179, 188
 schematic symbols, 191
alderflies, 43, 52
algae, 6, 34, 36, 38–39, 40, 41, 42, 43, 44,
 46, 47, 50, 77, 198
algae blooms, 198
alkalinity, 74, 77, 79, 213
 enhanced biological nutrient removal,
 215
 hardness, and, 80
 nitrification, 204
allochthonous material, 6, 7, 43
allowance, 117
alluvial streams, 29
alphabet of lines, 99–113
alternating current (AC), 169, 170
alum, 78, 199, 212, 214, 215, 216
aluminum chloride, 213
aluminum salts, 199
aluminum sulfate, 199; *see also* alum
American Institute of Architects (AIA), 87
American National Standards Institute
 (ANSI), 86–87, 100, 139, 165
American Society of Mechanical
 Engineers (ASME), 87
American Welders Society (AWS), 87, 139
ammonia, 198
ammonia nitrogen, 203, 204
amperes, 149
amphipods, 36
angular dimensions, 120
anion, 63, 72

anoxic activated sludge system, 205
apparent color, 74
approvals block, 89–90
aquatic ecosystem, 16, 18, 19, 23–24, 32,
 197
aquatic food chain, 15–16
aquatic food web, 16
aquatic organisms, 197, 198
 adaptations, 36–38, 42
 classification of, 34–36
 mouth shape, 37–38
architectural drawings, 149
arc welding, 139
 symbols, 141
arrowhead, 142, 143
arrowless dimensions, 122
artificial selection, 11
assembly drawings, 87, 88
atom, 63, 64, 66, 67–68
atomic number, 67, 68, 69, 70
atomic weight, 67, 68, 69
audio circuit, 161
aufwuchs, 34
autecology, 3
autochthonous food, 6, 43
autotrophs, 14, 56
auxiliary views, 113
Avogadro's number, 70

B

backswimmer, 13
backwash, 200, 201, 202, 203, 206, 207, 213
 temperature, and, 203
bacteria, 6, 15, 34, 40, 74–75
 denitrification, 205
 fecal coliform, 212, 214
 nitrifying, 203, 204
ball valve, 184
bar screen, 84–86
bare-rock succession, 22–23
bars, stream, 31–32
bases, 77
basic size, 116, 117
battery, 148, 159, 161, 168, 171
bed load, 29, 31
bedrock streams bed load, 29
beetles, 34, 37, 39, 42, 43, 48–50
behavioral adaptations, 37
behavioral ecology, 3, 10
bell-and-spigot joint, 180
bend radius, 130
 allowance, 129
benthic habitat, 38–56
benthic macroinvertebrates, 39–43
 identifying, 41–42
benthos, 34, 37
bicarbonates, 79
bilateral tolerance, 118

bill of materials, 90–91, 138
 bioadditives, 199
 biochemical oxygen demand (BOD), 197,
 198, 207, 208
 bottles, 19
 carbon adsorption, 207
 denitrification, 205
 enhanced biological nutrient removal, 212
 biocoenosis, 10
 biodisc, 203
 biogeochemical cycles, 14, 15, 56
 bioindicators, 40–41, 49, 54
 biological denitrification, 205–206
 biological nitrification, 203–204
 biological nutrient removal (BNR), 207,
 211–216
 biomass pyramids, 17–18
 biosolids, 62
 odor control, and, 81
 biosphere, 10, 13
 biotic factors, 14, 15, 56
 aquatic ecosystem, 23–24
 biotype, 10
 birth rate, 20
 blueprints, 83–191
 case study, 84–86, 94–96, 99–100
 information found on, 87–97
 welding, 138–146
 braiding, 30
 brazing, 140
 break lines, 104
 bromine, 68
 buffering, 79
 burrowers, 42
 butt joints, 140
 welded, 180

C

caddisflies, 35, 36, 39, 41, 43, 45–47, 48
 calcium, 14, 77
 ions, 80
 calcium carbonate, 73, 80
 ionization, 72
 calcium hydroxide, 77
 capacity, infiltration, 27–28
 carbohydrates, 15
 carbon, 14
 carbon-12, 70
 carbon adsorption, 206–207
 carbon dioxide, 13, 63, 74, 79
 carbonaceous biochemical oxygen
 demand, 203
 carbonates, 79
 carbonic acid, 23, 76
 carnivores, 16, 17
 carrying capacity, 21
 cases, caddisfly, 46–47
 casing, centrifugal pump, 124
 cation, 63, 72, 75
 cellulose, 6
 center line, 101, 109, 111
 centrifugal pump
 components, 124–125
 machine drawing, 123–125
 chamfer, 143, 144

change block, 91–92
 changes, chemical vs. physical, 66
 channelized streams, 31
 channels, stream, 30
 check valve, 183, 186
 chemical addition, 212, 213, 214, 215, 216
 chemical bonds, 66
 chemical compounds, 63, 69–73, 75
 chemical equations, 71
 chemical formulas, 68, 70–71
 chemical oxygen demand (COD), 207, 216
 chemical reaction, 66, 67, 71, 148
 chemical symbols, 67–68, 70–71
 chemical treatment, 198–199
 chemistry, water, 61–81
 chemosynthesis, 14
 chloride, 63
 chlorination, 212, 216
 chlorine, 67, 76, 81, 213, 214, 215
 atomic number, 68
 circuit breaker, 150, 151, 173
 current ratings, 150
 circuit drawings, 149–151, 168–178
 circuit layout, 161
 clarification
 primary, 214, 215, 216
 recarbonation, 215
 secondary, 212, 213, 214, 215, 216
 tertiary, 214, 215, 216
 tube settler, 212, 214
 Clements, Frederic E., 10
 climate regime, 14
 climbers, 42
 clingers, 42
 clumped population distribution, 21
 coagulation, 198, 206, 212, 213, 214
 control of, 78
 coarse particulate organic matter (CPOM),
 7
 coarse screening, 84
 cock valve, 184
 Coho salmon, 37
 Coleoptera, *see* beetles
 collectors, 41, 44
 colloidal solids, 63, 64, 73
 color
 aquatic organism, 38
 water, 74
 communities, 12–13, 16, 17, 32, 56
 community ecology, 3, 10
 company name and location, 88
 component drawing, refrigeration, 156
 compounds, 63, 69–73, 75
 compressor, 187, 189
 concentration (formula), 63
 conductance, specific, 80
 connecting lines, 164
 conservation, of energy, 15
 consumers, 14, 15, 17, 56
 primary, 16
 contact chambers, 206, 207
 contacts, electrical, 174
 contaminants, 73, 74
 contamination, fluid power system, 182
 contiguous population distribution, 21
 contour symbol, 145

controls, symbols for, 134
conversions
 minutes and seconds to decimal
 degrees, 120
 of commonly used units, 97
coolant, 153
copper, 67
copper sulfate, 77
Corixa, 13
corner joints, 140
corrosion, 79, 80, 206
 control of, 78
critical loads, 150
crossovers, 165
crustaceans, 34, 36, 39
current
 stream
 adaptations to, 36–38, 39
 velocity, 28–30
 electric, 148, 149, 168–169, 173
 maximum, 150
 ratings, of circuit breakers, 150
cutting plane line, 103
cylindrical part drawing, 109

D

damsel flies, 8, 34, 42, 43, 53–54
darning needles, 53
Darwin, Charles, 2, 9
dash letter, 92
dash number, 89
datum, 119
death rate, 20
dechlorination, 212, 213, 214, 215, 216
decimal dimensions, 115
decimal fraction, 98
decomposers, 14, 15, 16, 23, 56
decomposition, 34
degree (angle), 120
denitrification, 203, 205–206, 215
denominator, 98
deposition, 29, 30, 31, 38
design size, 117
detail drawings, 87–88
detention time, 207
detritivores, 15
developed length, 129–130
development, 129, 131
dextral snail shell, 55–56
DIA, 109
dimension lines, 101–102
dimensioning, 114–122
dimensions, weld, 142, 144
dimmer switch, 174
Diptera, *see* true flies
direct current (DC), 169, 170
discharge, 27, 28–30, 31
disinfection, 212, 213, 214, 215, 216
 turbidity, and, 74
disinfection byproducts (DBPs), 76
dissociation, 72
dissolved load, 29
dissolved oxygen (DO), 19, 23, 34, 74–75,
 197
 caddisflies, and, 47

 carbon adsorption, 207
 denitrification, 205
 filtration influent, 203
 lack of, 21
 nitrification, 204
dissolved solids, 63, 64, 73, 74, 80
distilled water, 78, 80
divers, 42
dobsonflies, 35, 42, 43, 52
double-line drawing, 189
dragonflies, 8, 34, 41, 43, 53–54
drawing change notice (DCN), 92
drawing conventions, 86
drawing notes, 92–93
drawing number, 89
drawing size, 89
drift, 35–36
drifters, 34
dropping resistor, 170
dual filters, 202
dual-media, gravity-bed filters, 214, 215,
 216
duct-duct air conditioning system, 158
DynaSand® filters, 212–213

E

echolocation, 50
ecological pyramid, 17–18
ecological succession, 21–23
ecologists, 5, 6
ecology, 1–57
 behavioral, 10
 community, 10
 defined, 2–4, 56
 evolutionary, 10
 father of, 9
 history of, 8–12
 human, 10
 importance of, 4–5
 physiological, 10
 plant vs. animal, 11
 population, 3, 10, 19–25
 stream, example of, 7–8
 subdivisions of, 3
ecosystem, 2, 10, 13–15, 57
 aquatic, 16, 18, 19, 23, 32
 classification, 11–12
 climax, 23
 components of, 14
 ecology, 3, 4
 energy, 15–16
 source of, 15
 fabricated, 11
 freshwater, 24
 natural, 11
 patterns, 12
 productivity, 18–19
edge joints, 140
effluent
 biochemical oxygen demand, 205
 enhanced biological nutrient removal,
 212
 infiltration–percolation, 208
 nitrate concentration, 205
 nitrified, 203

- nutrients, 198
- overland flow, 208
- polished, 207, 213
- secondary treatment, 197, 200, 203, 207
- streams, 28
- electric-arc welding, 139
- electric-resistance welding, 139
- electrical drawings, 146–152
 - size of, 151
 - symbols used on, 147
 - troubleshooting, and, 147
 - types of, 149–152
- electrical power supply line symbols, 168
- electricity, 148–152, 158–178
- electromotive force (emf), 148
- electron, 67, 80, 148
- electronics, 169–171
- element, 64, 67–68
- emigration, 20, 21
- emulsion, 62–63
- energy
 - dissipation, 14, 15, 17
 - ecosystem, 15–16
 - pyramids, 17
- engulfers, 41
- enhanced biological nutrient removal (EBNR), 211–216
- entrainment, 29
- entropy, 15
- environment, four parts of, 3
- environmental carrying capacity, 21
- Ephemeroptera, *see* mayflies
- erosion, 30, 31, 38, 210
- eutrophication, 198
- evaporation, 208
- evaporator, 154–158, 189
- evapotranspiration, 27
- evolutionary ecology, 10
- extended aeration, 212, 215
- extension lines, 103

F

- farm system, 12
- fecal coliform, 212, 214
- ferric chloride, 216
- field weld symbol, 146
- filter, electrical, 170–171
- filter underdrains, 203
- filterer, 7
- filtration, 199, 200, 201–203, 208, 212, 214, 215, 216
- fine particulate organic matter (FPOM), 7
- finish block, 90
- finish symbol, 146
- first law of thermodynamics, 15
- fish ladder, 20
- fittings, symbols for, 189
- fixed resistor, 174
- flanged joint, 180
- flatworms, 36
- floc, 199
 - pH, and, 78
- flocculation, 199, 200, 212, 213, 214, 215
- flood plain, 32–36
- floor plan, 149

- flow
 - equalization, 204
 - fluid, control of, *see* valves
 - heat, 153, 154
 - rate, irrigation, 210
 - water, in a stream, 27–28
- fluid power system, 131–133, 178; *see also*
 - hydraulic system, pneumatic system
 - symbols for, 133–136, 162–163, 187–191
 - valves, 181–186
- fluidized sand bed, 205
- food chain, 15, 16
 - 10% rule, 16–17
 - aquatic, 15, 16
 - efficiency, 16–17
- food web, 16
 - aquatic, 16
 - macroinvertebrates, and, 42–43
- fractions, 97–99
 - decimal equivalents of, 99
- freshwater ecosystem, 24
- friction, 28, 29, 148
- front view, 107, 112
- fungi, 6, 15, 34
- fuse, 173, 175

G

- gaining streams, 28
- gases, 64, 65, 66, 132, 133, 153, 154, 178, 179, 182, 187
- Gastropoda, 55–56
- gas weld symbols, 141
- gas welding, 139
- gate valve, 184, 185
- gatherers, 44
- gearing, valve, 184
- general notes, 93
- genetics, population, 9
- genotypic adaptations, 37
- glacial till, 25
- globe valve, 185–186
- grazers, 44
- grit removal and screening, 212, 213, 214, 215, 216
- groove angle, 145
- groove welds, 141
- gross primary productivity, 18
- groundwater, 28, 29, 208
 - nitrate in, 211

H

- habitat, 13, 32–33
- hardness, 73, 80
- head loss
 - carbon contactor, 206
 - denitrification, 206
 - filtration, 202, 203
- head pressure, 154
- heat, 148
- heat pump, 157
- heavy metals, 75, 198, 215
- hellgrammites, 52
- Hemiptera, *see* water striders
- hem, sheet metal, 131

herbicide, 210
herbivores, 16, 17, 18
heterotrophs, 14, 18, 57
hidden lines, 101
Hirudinea, 54, 55
homeostasis, 13, 57
human ecology, 10
humic acids, 14, 79
hydraulic system
 components, 132
 drawings, 131–138
 bill of materials, 138
 graphic symbols for, 133–136
 sequence of operations, 137
 solenoid chart, 138
 types of, 133
 schematics, 187–191
hydrochloric acid, 76
hydrogen, 14, 67, 69, 76
 atomic weight, 67
 burning, chemical equation for, 71
 ions, 64, 77, 78, 79
hydrogen peroxide, 81
hydrogen sulfide, 81, 206, 207
hydrologic cycle, 208
hydronium, 64
hydrophytes, 42
hydroxide, 64
 ions, 77
Hyphomycetes, 6
hypochlorite, 201

I

immigration, 20, 21
impeller, 124, 125
impeller–bowl assembly, 126–127
impurities, 73, 75
Indiana dunes, 10
induction air conditioning system, 158
inductor, 172
infiltration capacity, 27–28
infiltration–percolation, 207–209
 performance levels, 208–209
influent streams, 28
inorganic matter, 14, 64, 76
insect larvae, 6, 15, 34, 35, 36, 39, 41, 43, 43–54
insecticide, 210
intermittent stream, 28
International Organization for
 Standardization (ISO), 86–87
International System of Units (SI), 97, 114
interrelationships, environmental, 3, 4, 9, 10
interrupted paths, 164, 165
invertebrates, 7
iodine, 68
ion, 63, 64, 72, 75
ionization, 64, 72
iron, 67, 74
irrigation, 207, 208
 performance levels, 208
isopods, 36
isotope, 70

J

jar test, 202
joints
 piping, 179–181
 sheet metal, 131
 welded, 139–140

L

ladder drawing, 149, 151
laminar flow, 29
lamp dimmer circuit schematics, 160
land application, 207–211
lap joints, 140
large woody debris (LWD), 35
laws of thermodynamics, 15
leaders, 103
leaf-pack processing, 7
leaves, 6–11
leeches, 39, 43, 54, 55
left-handed snails, 55–56
lentic freshwater systems, 26, 42
levels of organization, 12–13
lichens, 23
light, 148
lignin, 6
lime, 78, 199, 204, 215
 precipitation, 80
limiting factor, 32
limits, tolerance, 118
linear bend length, 130
linear dimensions, 119–120
linear measurements, 97
line gauge, 106
lines, blueprint, 99–113
lines, schematic, 162–163, 167
liquids, 64, 65, 66, 132, 133, 153, 154, 155, 156, 157, 178, 179, 182, 187
littoral zone, 13, 38
load
 electrical, 169, 170, 171
 noncritical, 150–151
 sediment, 29
 suspended solids, 29, 30
 traction, 30
 wash, 29, 30
local notes, 93
location dimensions, 118
long-break line, 104
losing streams, 28
lotic freshwater systems, 26, 33, 42, 43–56
lung-breathing snails, 55–56

M

machine drawings, 122–127
macroconsumers, 36
macroinvertebrates
 benthic, 39–43
 food web, and, 42–43
 insect, 43–54
 mode of existence, 41, 42
 non-insect, 54–56
 taxonomy, 43
madricoles, 34

magnesium, 77
 ions, 80
 magnetism, 148, 172, 173
 maintenance operator's toolbox, 94–96
 Malthus, Thomas, 9
 mass vs. weight, 65–66
 materials block, 90
 matter, 64, 65–66
 content of, 67–69
 mayflies, 6, 7, 15, 34, 36, 37, 39, 41, 42, 43, 44, 45, 46, 47, 48, 50
 mean cell residence time (MCRT),
 nitrification, 204
 meandering channels, 31
 measurement units, 97
 media loss, 203
 Megaloptera, 52
 melt-thru symbol, 146
 Mendel, Gregor, 9
 mercury, 62
 metamorphosis, 41, 46
 methanol, 205, 216
 microbial processing, 6–7
 microhabitat, 35
 microorganisms, 211
 microscreening, 200–201
 microstraining, 200
 minutes (angle), 120
 miscibility, 62
 mixed-media filters, 202, 214
 mixture, 64
 mode of existence, macroinvertebrate, 41, 42
 molecule, 64, 68, 69, 70
 moles, 70
 mortality, 20, 21
 mosquito hawks, 54
 mosquitoes, 48, 54
 mosses, 6, 23, 36, 39, 42
 motor circuit, 174–175
 mouth shape, 37–38
 mud balls, 203
 mud dwellers, 34
 municipal wastewater phosphorus
 concentration, 212
 mutual inductance, 172

N

natality, 20, 21
 natural organic matter (NOM), 76
 nektons, 34, 36
 nematodes, 39
 net community productivity, 18
 net primary productivity, 18
 neustons, 34
 neutrons, 67, 70
 niche, 13, 57
 nitrate, 211
 nitrate nitrogen, 203, 205
 nitric acid, 76
 nitrification, 198, 203–204, 212, 215
Nitrobacter, 203
 nitrogen, 14, 32, 68, 76, 198, 207, 208, 210, 211; *see also* denitrification, nitrification

Nitrosomonas, 203
 nominal pressure (PN), 182, 183
 nominal size (DN), 116, 182
 noncritical loads, 150–151
 nonpolar substances, 72, 73, 76
Notonecta, 13
 nucleus, 67, 69, 70, 77
 number pyramid, 17
 numerator, 98
 nutrients, 15, 19, 32, 198
 nymphs, *see* insect larvae

O

oak-hickory forest, 23
 object line, 100–101
 Odonata, 53–54
 odor, 74, 75, 211
 control, 80–81
 Odum, Eugene P., 10
 Odum, Howard, 10
 oecology, 11
 old-field succession, 23
 Oligochaeta, 54, 55
 one-view drawing, 108–109
 ontogenetic adaptations, 37
 organic matter, 6, 7, 14, 18, 38, 42, 64, 73, 75–76
 accumulation, 18
 denitrification, 205
 pioneer community, 23
 organisms, aquatic, 197, 198
 adaptations, 36–38, 42
 classification of, 34–36
 mouth shape, 37–38
 orthographic projections, 106–107
 overland flow, 27, 207, 208
 performance levels, 208
 oxidation, 81, 208
 oxyacetylene welding, 139
 oxygen, 13, 14, 68
 production, 19
 ozone, 81

P

packed bed, 206
 packing gland machine drawing, 125
 particle movement, 29–30
 particle size, 7, 29, 30, 31, 35, 62, 63, 73
 parts list, 90–91, 138
 pelagic organisms, 34
 perennial stream, 28
 periodic table, 68–69
 periphytons, 34
 petroleum, 62
 pH, 74, 75, 77–78, 79
 denitrification, 205
 enhanced biological nutrient removal, 215
 nitrification, 204
 pollution, and, 78
 seawater, 78
 phantom lines, 104–105
 pharmaceuticals, in municipal
 wastewater, 212

phenotypic adaptations, 37
phosphate, 39
phosphorus, 68, 76, 198, 207, 208, 210, 211
 removal, 211–216
photosynthesis, 6, 14, 15, 16, 18, 19, 27, 42
physiological ecology, 10
phytoplanktons, 15, 34
 pictorial view, 106–107, 166
 piercers, 41
pioneer community, 23
pipe, 179
piping
 deterioration, 209
 joints, 179–181
 refrigeration, symbols for, 189–190
 schematics, 178–186
 system, 179, 187
planktonic macroinvertebrates, 42
planktons, 34
plant community as complex organism, 10
Plantasamfund, 9
plant geography, 9
plan view, 107
Plecoptera, *see* stoneflies
plot plan, 149
PN, *see* nominal pressure
pneumatic system
 components, 132–133
 drawings, 131–138
 bill of materials, 138
 graphic symbols for, 133–136
 sequence of operations, 137
 solenoid chart, 138
 types of, 133
 schematics, 187–191
polar substances, 72
pollutants, 73, 79
pollution, 19, 57
 bioindicators, and, 40
 pH, and, 78
polyaluminum chloride, 214
polyaluminum silicate sulfate (PASS), 212
polymers, 199
ponding, 209
pool-riffle sequence, 32
pool zone, 33, 34
pools, 31–32, 42
population
 density, 20
 distribution, 20–21
 ecology, 3, 10, 19–25
 genetics, 9
 growth, 9
potassium, 77
potassium hydroxide, 77
potassium permanganate, 81
potential, difference in, 148
potentiometer, 174
power, electric, 149, 168–174
power smoothers, 170
power supplies, 168–171
precipitate, defined, 64
precipitation, 27, 213, 215
 chemical, 81
 lime, 80
predators, 41
pressure
 refrigeration system, 154–158
 voltage produced by, 148
primary clarification, 214, 215, 216
primary consumers, 16
primary production, 38
primary productivity, 18
primary succession, 22–23
producers, 14–15, 16, 17, 18, 36
productivity, ecosystem, 18–19
proton, 67, 69, 70
 number, 67
protozoans, 6, 34
pulmonary cavity, 55
pump
 centrifugal, 123–125
 hydraulic system, 187
 irrigation, 210
pupae
 beetle, 48
 caddisfly, 46
 true fly, 48
pyramid, ecological, 17–18

R

radical, 64
rainwater, 27
random population distribution, 20
raw domestic wastewater phosphorus
 concentration, 211–212
RC series circuit schematic, 159
recarbonation, 215
receiver, pneumatic system, 187
recharge basins, 208
rectifier, 169, 170
REF, 121
reference dimensions, 121
reference line, 142, 143
refrigerant, 153–158, 157
refrigeration, 153–156
 component drawings, 156
 components, 154
 drawings, 155–156
 piping, 189
 schematics, 188–191
regular population distribution, 20–21
reservoir, hydraulic system, 187
residual solids, 62
resistance weld symbols, 141
resistance welding, 139
resistor, 174
reversing starter, 174–175
revision block, 91–92
rheotaxis, 37
ridge-and-furrow surface spreading, 208
riffle beetle, 49
riffle zone, 33
riffles, 31–32, 42
right elevation, 107, 111, 112
right-handed snails, 55–56
riser diagram, 149
rocks, measuring, 35
rotary devices, symbols for, 134
rotating biological contactor (RBC), 204, 214

rotating drum, 200, 201
rotifers, 34, 39
running waters, *see* lotic freshwater systems
runoff, 27, 29
run zone, 33–34

S

saltation, 30
salts, 77, 79, 199
saturated solution, 64
saturation, 75
S break, 104
scale, 80
drawing, 88–89
schematics, 83–84, 158–166
air conditioning, 188–189, 191
audio circuit, 161
electrical, 166–175
symbols used on, 167–174
electronic power supply, 169–170
example diagram, 163–165
hydraulic system, 187–191
ladder drawing, 151
piping, 178–186
pneumatic system, 187–191
RC series circuit, 159
reading, 174–175
refrigeration, 188–191
symbols used on, 162–163
electrical, 167–178
fluid power systems, 188–191
joints, 180–181
valves, 184–186
troubleshooting procedure, 165–166
schooling, 38
scour, 30, 202, 203, 207, 213
scrapers, 41
screwed joint, 180
scrubbing, chemical, 81
seawater, 78, 80
second law of thermodynamics, 15, 17
secondary clarification, 212, 213, 214, 215, 216
secondary productivity, 18
secondary succession, 22, 23
secondary treatment, 197, 198, 199, 200, 203, 207, 215; *see also* secondary clarification
effluent, 207
phosphorus removal, 211, 212
seconds (angle), 120
section lines, 101
sediment, 62
load, 29
self-contained breathing apparatus (SCBA), 84
self-ionization, 64
self-purification, 7, 24
set-back table, 129–130
settleable solids, 73, 198
settling, 206
characteristics, 199
tank, 199, 204
sludge blanket, 199

sewage, 21, 24, 55, 65, 197, 198, 204
shape, organism, 38
sheet metal drawings, 127–131
sheet number, 89
shop notes, 122
short-break line, 104
shredders, 7, 41, 44
single-line drawing, 150, 158, 189
sinistral snail shell, 55–56
sinuosity, 29, 30, 31
index, 31
skaters, 42
slime, 38, 200
sludge, 62, 199
anaerobic, 199
retention time, 204
volume index (SVI), nitrification, 204
worms, 55
smoothing section, 169
snails, 36, 41, 55
snowmelt, 25
social hierarchies, 21
socket welded joint, 180
soda ash, 71
sodium, 68, 77
sodium adsorption ratio (SAR), 209, 210
sodium bisulfate, 214
sodium carbonate, 71
sodium chloride, 70, 71
ionization, 72
sodium hydroxide, 77, 81, 204
sodium hypochlorite, 216
sodium nitrate, 207
sodium sulfate, 213
soldered joints, 181
solenoids, 138
solids, 64–65, 66, 73
backwash, 200
colloidal, 64, 73
dissolved, 63, 64, 73, 74, 80
load, 29
settleable, 73, 198
suspended, 62, 65, 73, 200, 201, 208
total, 65, 73
total suspended, 73, 197, 198, 200, 207, 212, 216
solubility, 62
solute, 65, 71, 75
solution, 71–72
saturated, 64
solvent, 65, 71
species diversity, 11, 21
pollution, and, 21
species, metal, 75
specific conductance, 80
sponges, 36
spot welds, 145
sprawlers, 42
sprinkler systems, 208, 209
stages, electronic device, 164
standard part, 88
standards, blueprint, 86–87
standards-setting organizations, 86–87
standing waters, *see* lentic freshwater systems
step-down transformer, 172

step-up transformer, 172
stoneflies, 7, 34, 36, 37, 39, 41, 43, 44–45,
46, 47, 48
stream
 channels, 30, 31
 competence, 29
 current, adaptations to, 36–38, 39
 defined, 26
 discharge, 28–29
 energy sources, 6
 flow, 27–28
 leaf processing, 6–11
 material transport in, 29–30
 profiles, 30–31
 structure, 25–38
 velocity, 28–30
submersible pump machine drawing, 126
succession, 21–25
suction pressure, 154
sulfides, 207
sulfur, 14, 68
sulfur dioxide, 213
sulfuric acid, 76
supplementary weld symbols, 142
surface runoff, 27
surface waters, 208
surge protection, 151
suspended growth denitrification, 205
suspended solids, 62, 65, 73, 208
 load, 29, 30
 removal, 200, 201
swimmers, 42
switch, electrical, 172
SYM, 101
synecology, 3
system lines, symbols for, 136

T

tabular dimensions, 121
tail, weld symbol for, 142, 146
Tansley, Arthur, 10
taxonomy, 43
tee joints, 140
temperature, water, 79
template, 129
tertiary clarification, 214, 215, 216
tertiary settlers, 212, 213, 214, 216
tertiary treatment, 198
thalweg, 31
Theophrastus, 9
thigmotaxis, 37
three-dimensional pictorial, 106–107
three-view drawings, 111–112
throttling, 185
title block, 88–92, 93
title of drawing, 88
toe biters, 52
tolerance, 90, 118, 120
top view, 107, 111, 112
total solids, 65, 73
total suspended solids (TSS), 73, 197, 198,
200, 207, 212, 216
toxicity, 204, 209, 210
traction load, 30
transformer, 149, 169, 170, 172

transpiration, 27
Trichoptera, *see* caddisflies
trickling filter, 203, 204, 214
trophic groups, of macroinvertebrates, 41
trophic level, 15–16
troubleshooting, 83, 94, 95
 air conditioning and refrigeration
 systems, 153–158
 electrical drawings, and, 146, 147,
 149–152, 169
 procedure, 165–166
 schematics, and, 162–166
true color, 74
true flies, 7, 36, 43, 47–48
tube settlers, 212, 214
Tubifex, 55
tubing, 187
turbidity, 65, 73–74
 carbon adsorption influent, 206
 enhanced biological nutrient removal, 212
 filtration effluent, 202
turbine pump machine drawing, 126–127
turbulent flow, 29
two-stage filtration, 212, 213
two-view drawings, 109–111

U

ultimate carrying capacity, 21
ultraviolet disinfection, 212, 213, 214, 216
underdrains, 203
uniform population distribution, 20–21
unilateral tolerance, 118
units of measurement, 97–98
U.S. Customary System (USCS), 97
U.S. Department of Agriculture
 agrosystem model, 11–12

V

valves, 179, 181–186, 187
 construction of, 183
 symbols for, 136, 184–186, 190
 types of, 184–186
 working pressure of, 182–183
variable air volume, 158
variable resistor, 174
velocity
 chemical treatment, 199
 entraining, 29
 water, 28–30
viewing plane line, 103
viewpoint, 107
views, blueprint, 106–113
viruses, 215
visible lines, 100–101
voltage, 148
 regulator, 170
volume, 66
volute casing, 124
von Humboldt, Friedrich Alexander, 9

W

Warming, Johannes E.B., 9
wash load, 29, 30

- water
 - as solvent, 71
 - chemistry, 61–81
 - color, 74
 - constituents, 73–78
 - cycle, 208
 - ecology, 1–57
 - measurements, 78–81
 - molecule, chemical formula for, 68
 - table, 28
 - temperature, 79
 - velocity, 28–30
- water beetles, 34, 39, 49
- water boatman, 13, 42
- water penny, 37, 41, 49–50
- water striders, 34, 42, 51
- watts, 149
- weathering, 23, 29
- weight vs. mass, 65–66
- weld-all-around symbol, 145
- welded joint, 180
- weld symbol, 141, 142, 144
 - vs. welding symbol, 141
- welding
 - blueprints, 138–146
 - joints, 139–140
 - processes, 139
 - symbols, 141, 142–147
 - special, 144–146
- Wentworth scale, 35
- whirligig beetles, 49, 50
- Willdenow, Carl Ludwig, 9
- wiring diagram, 166–167
- work, 149
- working drawings, 87
- worms, 39, 43, 54, 55

Z

- zooplanktons, 34

SECOND EDITION

Spellman's Standard Handbook *for* Wastewater Operators

VOLUME III Advanced Level

Compact and practical, **Spellman's Standard Handbook for Wastewater Operators: Volume III, Advanced Level, Second Edition** rounds out the revision of this three-volume set. Together, these three volumes prepare operators to obtain licensure and operate wastewater treatment plants properly. This volume presents applied math and chemistry by way of real-world problems, covers equipment maintenance, and explains apparatus used in the laboratory and in the field.

The third and final volume in the handbook features:

- Updated information on the latest technology
- Revised and restructured table of contents
- Updated problems, examples, and figures

The three volumes are designed to build on each other, providing increasingly advanced information. For persons preparing for operator's licensing, this is critical, because wastewater treatment is a complex process. For licensed veteran operators, continuous review is also critical, because wastewater treatment is a dynamic, ever-changing field. **Spellman's Standard Handbook** provides the vehicle for reaching these goals.

Treating wastewater successfully demands technical expertise, experience, and a broad range of available technologies — an operator needs to be a generalist — as well as an appreciation and understanding of the fundamental environmental and health reasons for the process involved — an operator also needs to be a specialist. Filling its mission to enhance the understanding, awareness, and abilities of practicing and future operators, this volume provides the vehicle for the continuous learning and reviewing required by the evolving, dynamic, and complex process of water treatment.



CRC Press
Taylor & Francis Group
an informa business
www.crcpress.com

6000 Broken Sound Parkway, NW
Suite 300, Boca Raton, FL 33487
270 Madison Avenue
New York, NY 10016
2 Park Square, Milton Park
Abingdon, Oxon OX14 4RN, UK

K10996



www.crcpress.com