

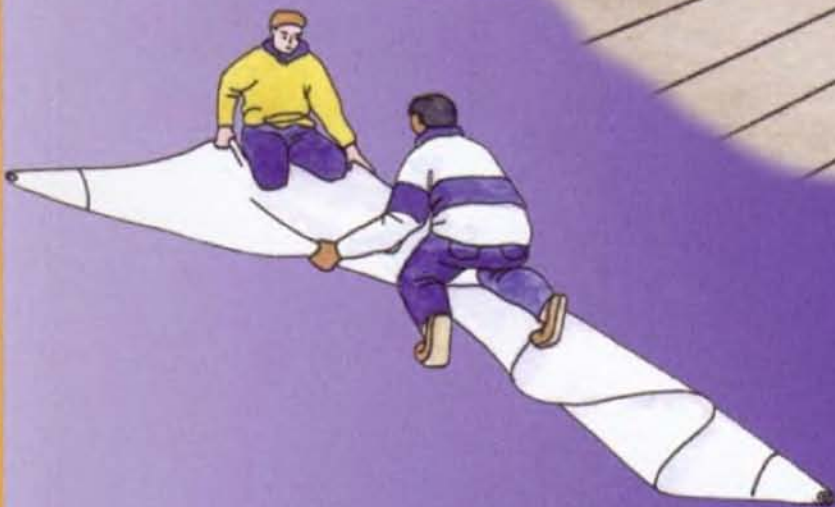

# competent crew

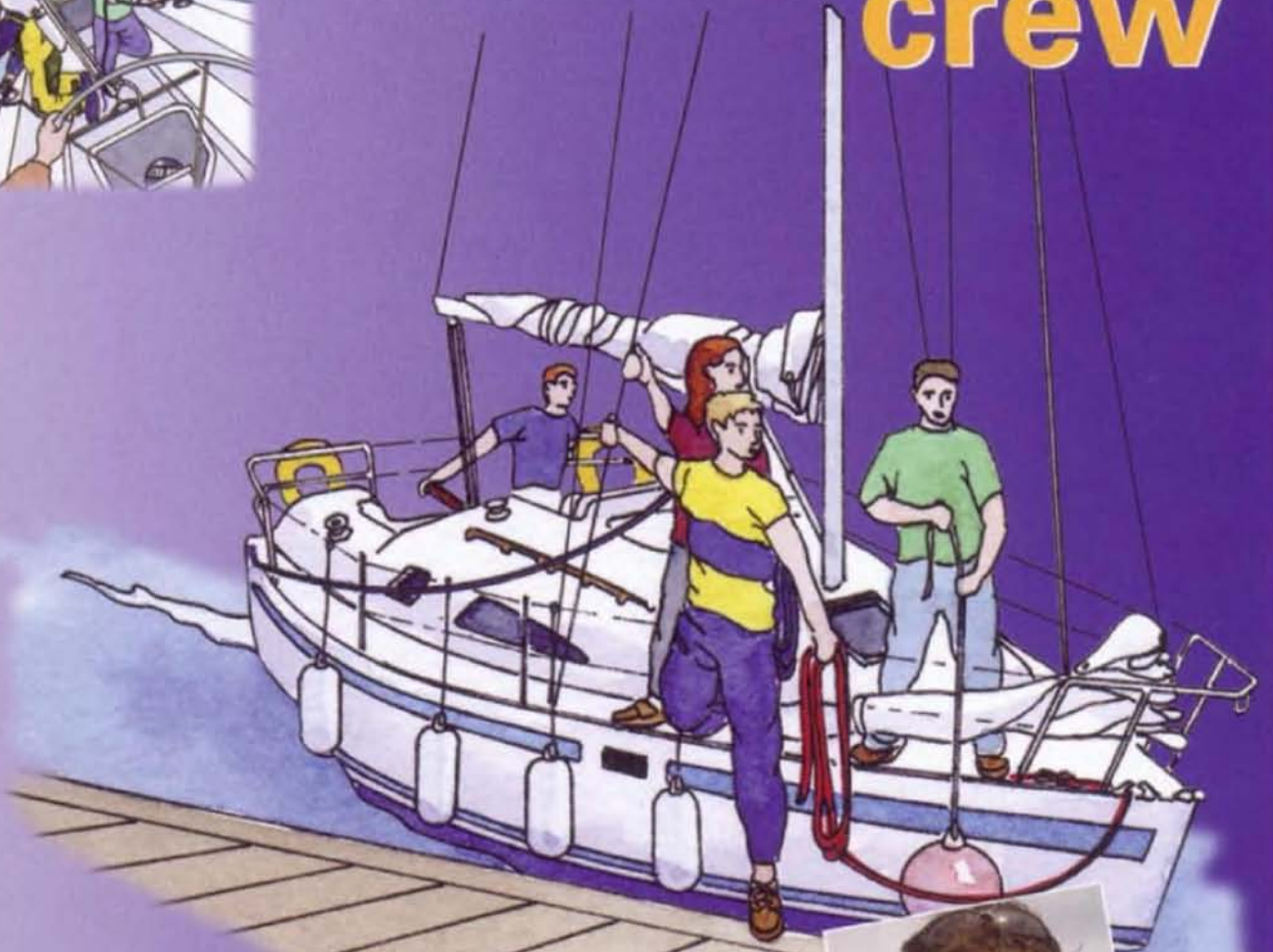

*"...This book will be a great help during your first few days afloat."*

*Ellen MacArthur MBE*

An introduction to yachting



# competent crew

**Written by Penny Haire and Sarah Hopkinson  
Illustrations by Sarah Selman**



[www.rya.org.uk](http://www.rya.org.uk)

**Royal Yachting Association**  
RYA House, Ensign Way, Hamble, Southampton SO31 4YA  
Tel: 0845 345 0400 Fax: 0845 345 0329  
email: [training@rya.org.uk](mailto:training@rya.org.uk) website: [www.rya.org.uk](http://www.rya.org.uk)

All rights reserved. No part of this publication may be transmitted, stored in a retrieval system, or transmitted, in any form or by any means, electronic, mechanical, photocopying, recording or otherwise, without the prior permission of the publisher.

© Royal Yachting Association 2002

Produced by: AVALON DESIGN+PRINT • Christchurch • Dorset

## CONTENTS

Foreword	3	Coming alongside in a marina	46-47
Introduction	4	Mooring alongside another boat	48
Nautical terms	5	Leaving a berth	49
Different types of yacht	6-9	Picking up a mooring	50
Parts of a sailing yacht	10-11	Anchoring	51
Parts of a sailing yacht - detail	12-13	Rules of the road	52
Knots	14-15	Who gives way?	53
Ropework	16-19	Keeping a look-out	54-55
Preparing the sails for sea	20-21	Watch keeping	56
Hoisting the mainsail	22-23	Sailing manners and nautical customs	57
Hoisting the Jib	24-25	Using the dinghy	58-59
Reefing the mainsail	26-27	Personal comfort	60
Changing headsails	28-29	Personal safety	61
Stowing the mainsail	30	Man overboard - actions to be taken	62
Stowing the jib	31	Fire	63
How sails work	32	Mayday	64
Points of sailing	33	Other distress signals	65
Sailing on the wind	34-35	Abandoning to the liferaft	66
Sailing upwind	36	Living aboard	67
Going about	37	Using the heads	68
Sail trim on a reach	38	Living afloat	69
Sailing downwind	39-41	Weather forecasts	70
Gybing under control	42-43	Beaufort wind scale	71
Steering	44		
Steering a steady course	45		

## FOREWORD



**S**ailing is the most exhilarating sport but you need to know the ropes. For the beginner, the best way to learn how to crew a yacht is to take an RYA Competent Crew Course. This book is the ideal companion to the course and you will find it a great help during your first few days afloat.

When I started sailing I lived and instructed at an RYA sea school in the North East. I worked my way up through the RYA Yachtmaster Scheme, first becoming a RYA Yachtmaster then a Yachtmaster Instructor. The skills I learned have been invaluable in my racing career and have been a major part of my success.

Enjoy your course and good sailing.

A blue ink signature of Ellen MacArthur, written in a cursive style.

Ellen MacArthur MBE

## INTRODUCTION



Penny Haire  
RYA Chief Cruising Instructor

Over 12,000 people, most with absolutely no sailing experience, successfully complete a RYA Competent Crew course every year. The courses are run by over 120 RYA Training Centres around the UK and overseas. Using a RYA recognised centre will ensure that you are taught to the RYA's high standards, and your course will be safe, informative and enjoyable.

This book *Competent Crew* has been written using the cumulative experience of hundreds of experienced sailing instructors. The techniques shown/described are tried and tested and are suitable for most types of cruising yacht. I hope that you enjoy the book and find it useful. Good sailing!



## NAUTICAL TERMS

It's worth learning the nautical terms because they are exact definitions of technical features, so no confusion, and they will help you understand the sport and learn more quickly. The nautical terms are used throughout this book.

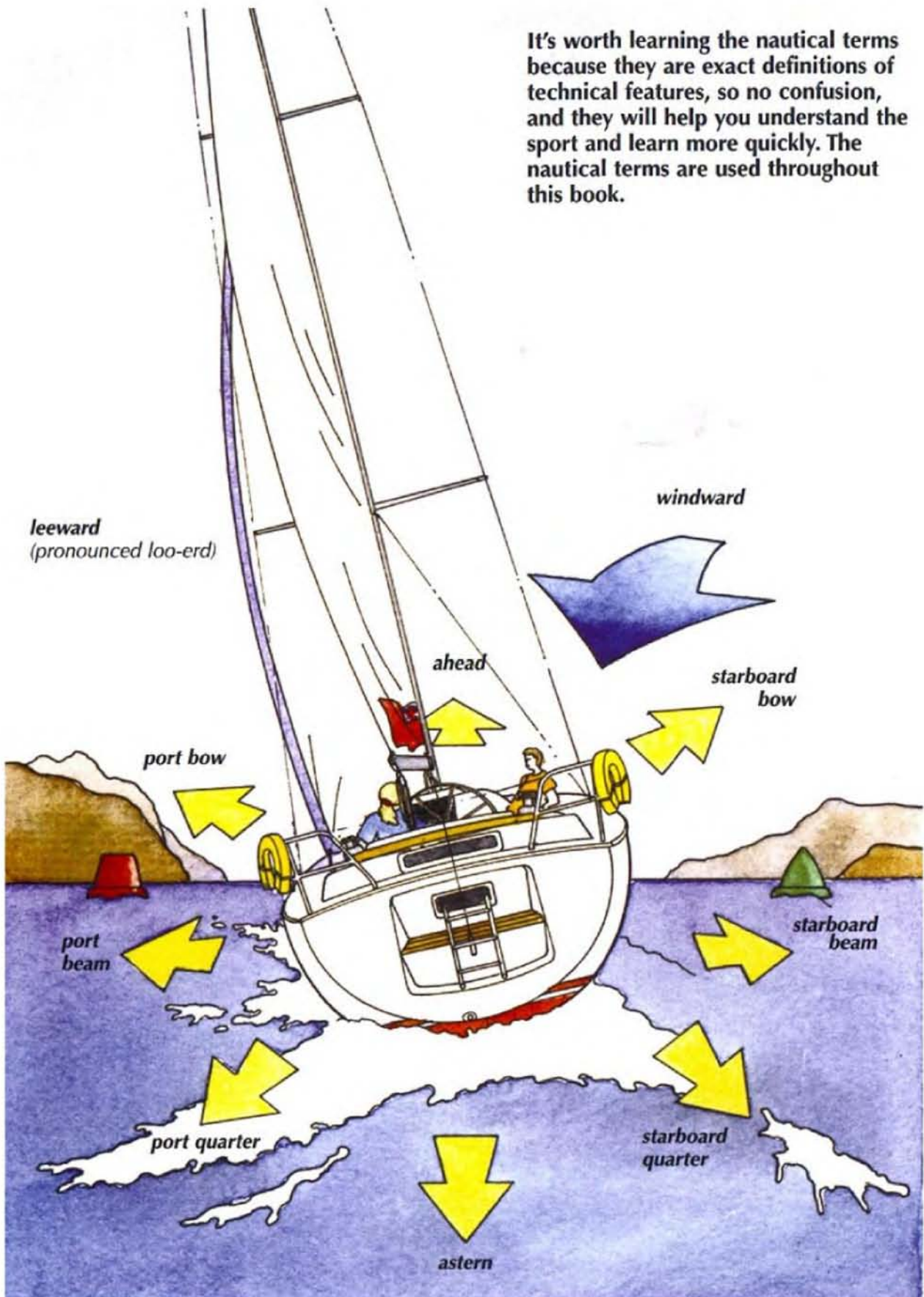

## DIFFERENT TYPES OF YACHT

### Cruiser racer

These boats mix good performance with comfort. When racing, heavy items can be removed from the boat. Many owners will have two sets of sails – one for cruising and one for racing.

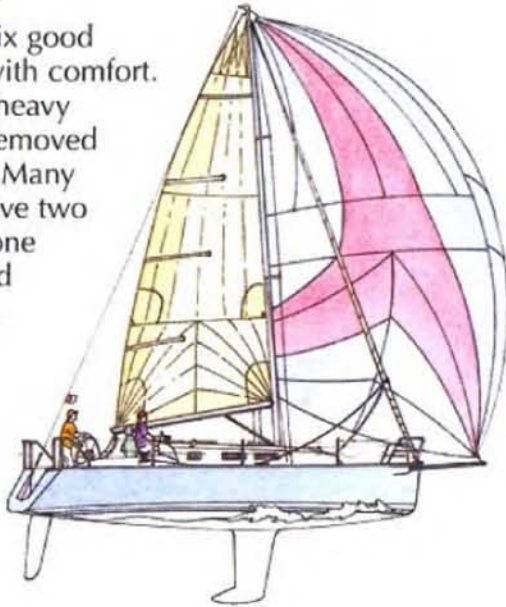

Sailing boats come in all shapes and sizes, and can be very specialised. Designers attempt to strike the right balance between comfort and performance.

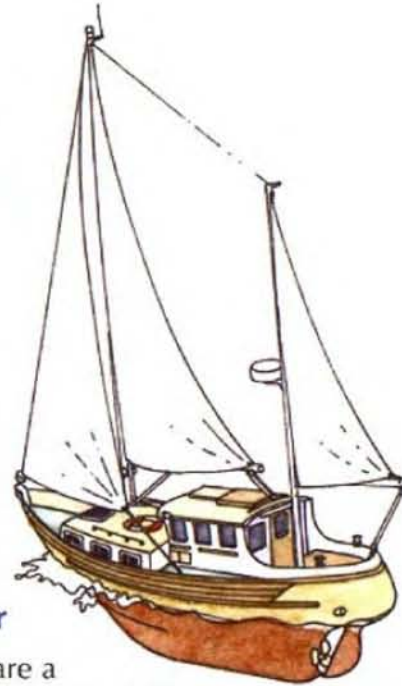

### Motor sailer

These boats are a compromise between sailing performance and comfort, with a powerful engine to get you there in adverse winds.

### Traditional craft

Many people enjoy sailing on this type of vessel. Used in the past for coastal trade – especially on the East coast.

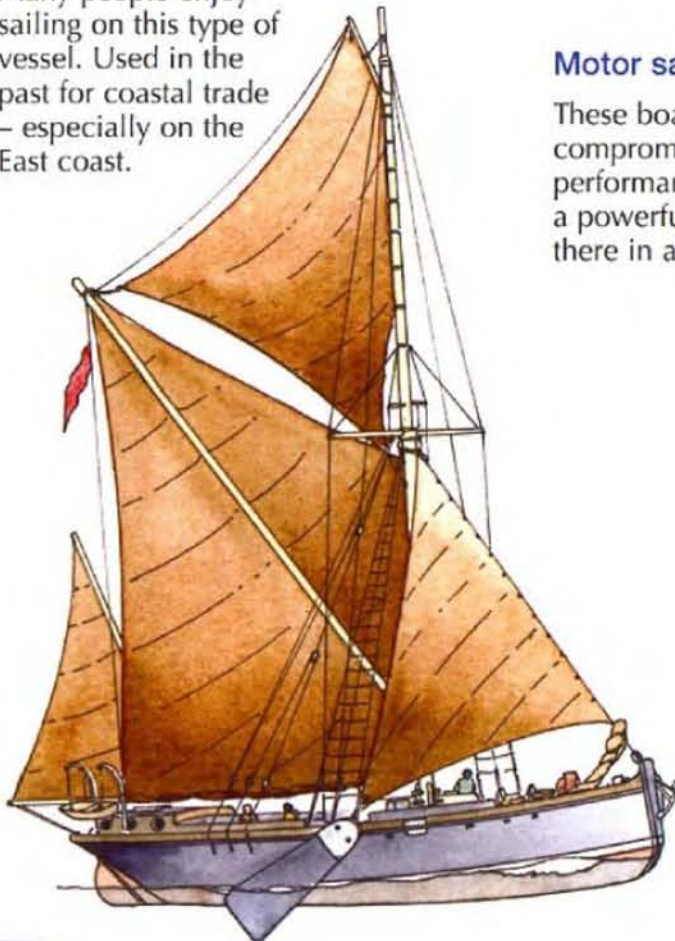

### Small cruiser with junk rig and bilge keels

Rig style from the Far East. Easily controlled by one person.

## DIFFERENT TYPES OF YACHT

### Small racing yacht or keelboat

Designed for day racing, mostly inshore. These boats are light, high performance, demanding and exciting to sail.

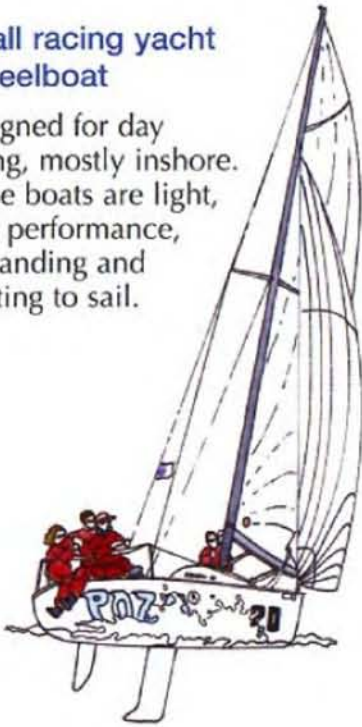

### Medium or large cruising yacht

Comfort, ease of handling, reliability and safety are usually the main features of this type of boat.

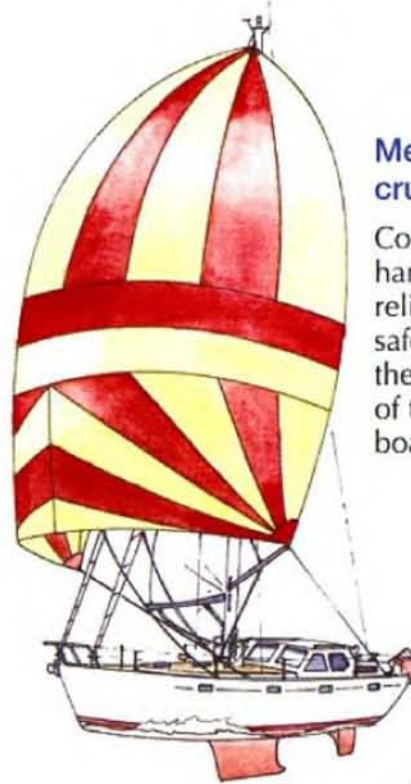

### Cruising catamaran

Multihulls can provide a combination of good performance and comfort. Many have undertaken long ocean passages.



### Cruising yacht with windsurfer rig

This type of rig is easy to handle when short-handed.



### Racing trimaran (3 hulls) or catamaran (2 hulls)

This is about as fast as you'll get to go on a sailing boat. Fast, exciting, unforgiving – for experienced sailors only!

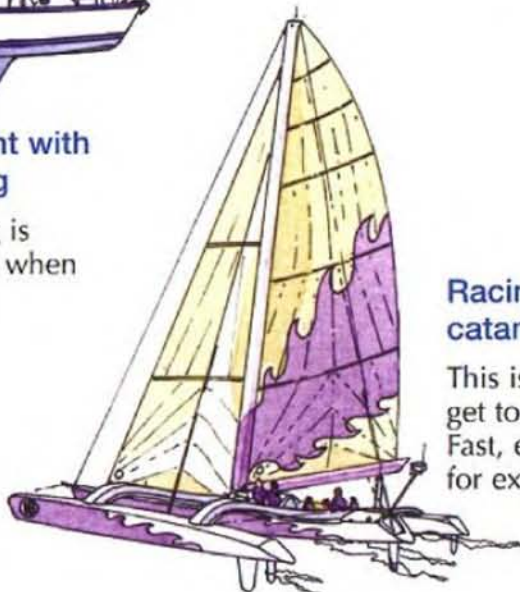



## DIFFERENT TYPES OF YACHT

### Square rigger

Restored or newly built boats are used for sail training and 'Tall Ships' events.

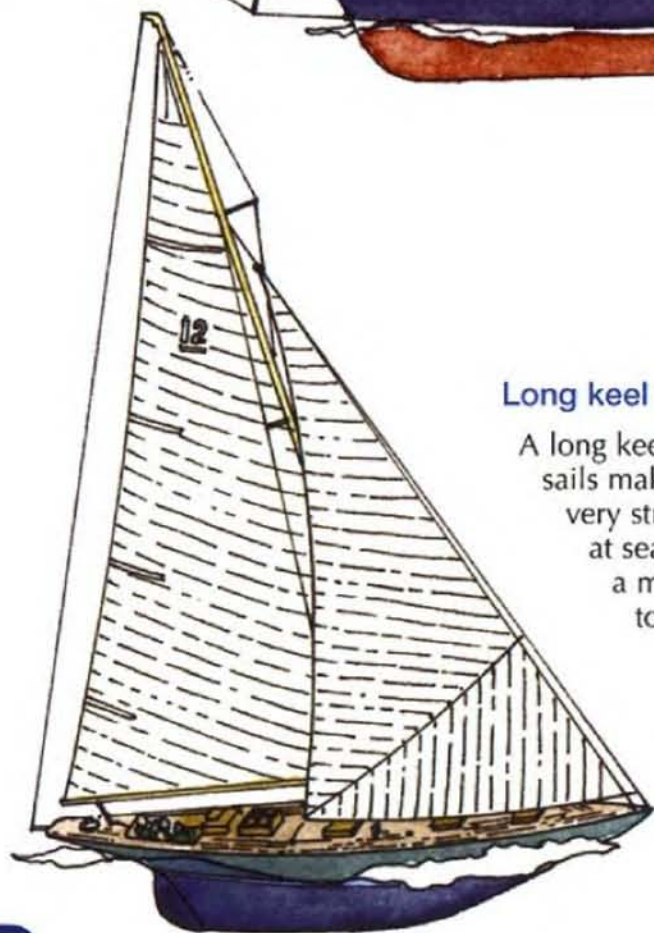
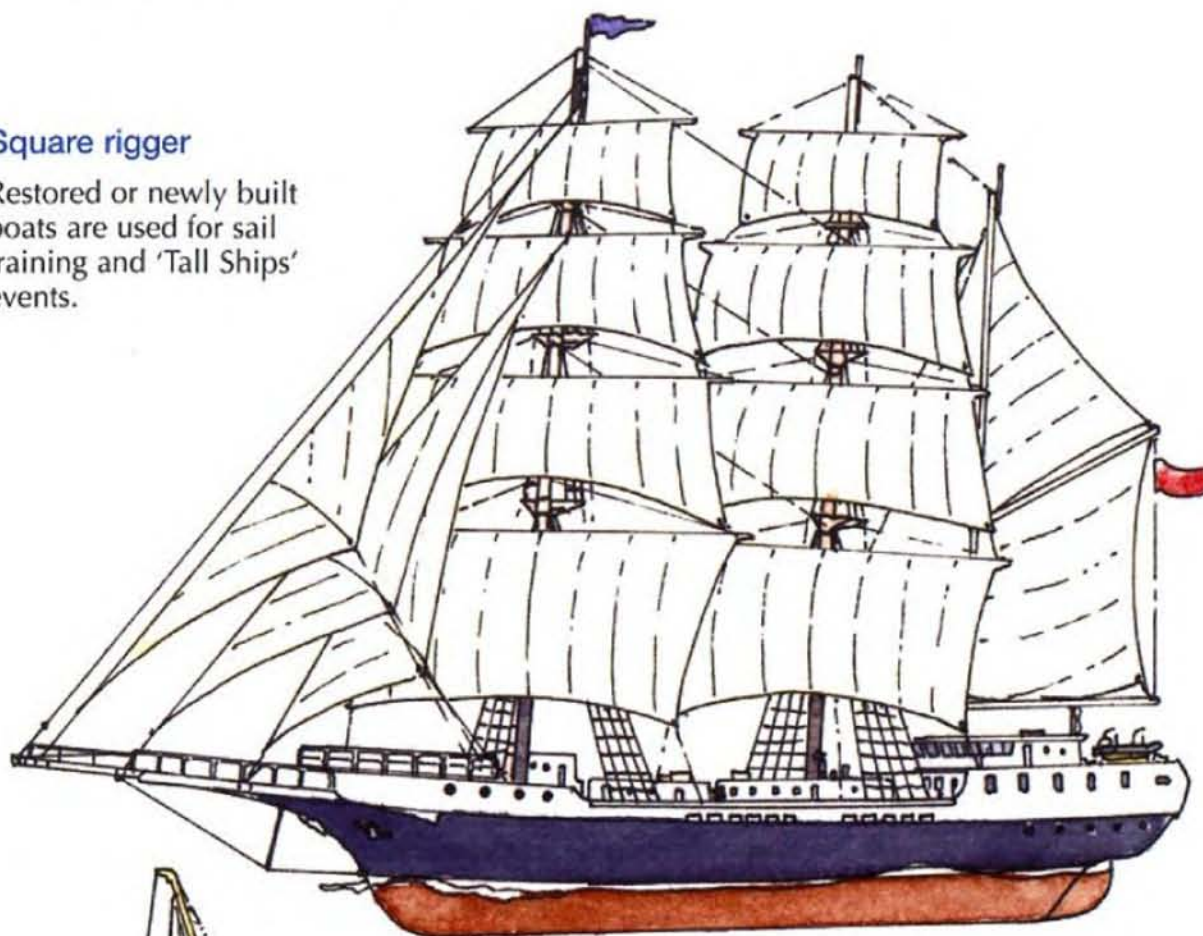

### Long keel classic craft

A long keel and well-balanced sails make these boats hold a very straight and steady course at sea – but under power in a marina they can be hard to manoeuvre.

**Luxury private/charter yacht**

Money is usually no object on a 'superyacht'. Most have a professional skipper and other paid crew.

Yachts like this often spend the winter in the Caribbean and the summer in the Mediterranean.

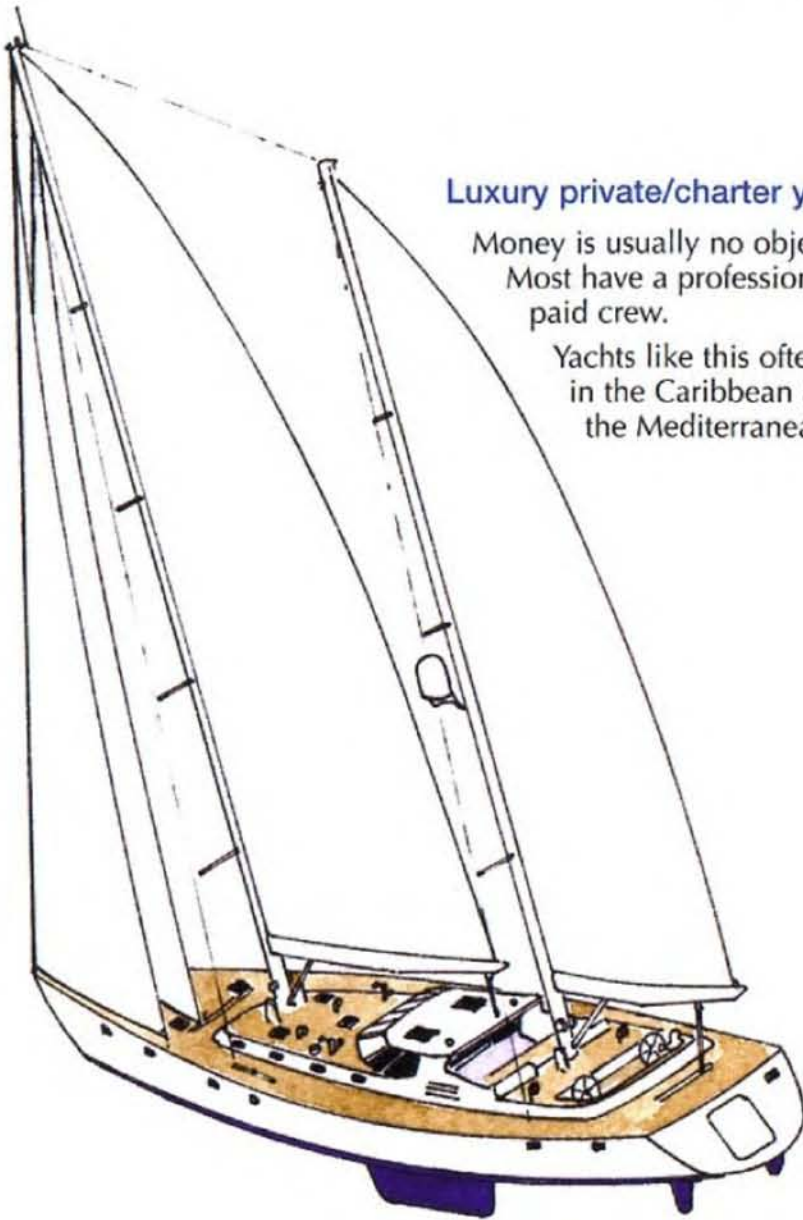

**Performance racing yacht**

Sails, rig and hull are usually made from hi-tech material making these yachts very light, strong and fast. They are demanding to sail.

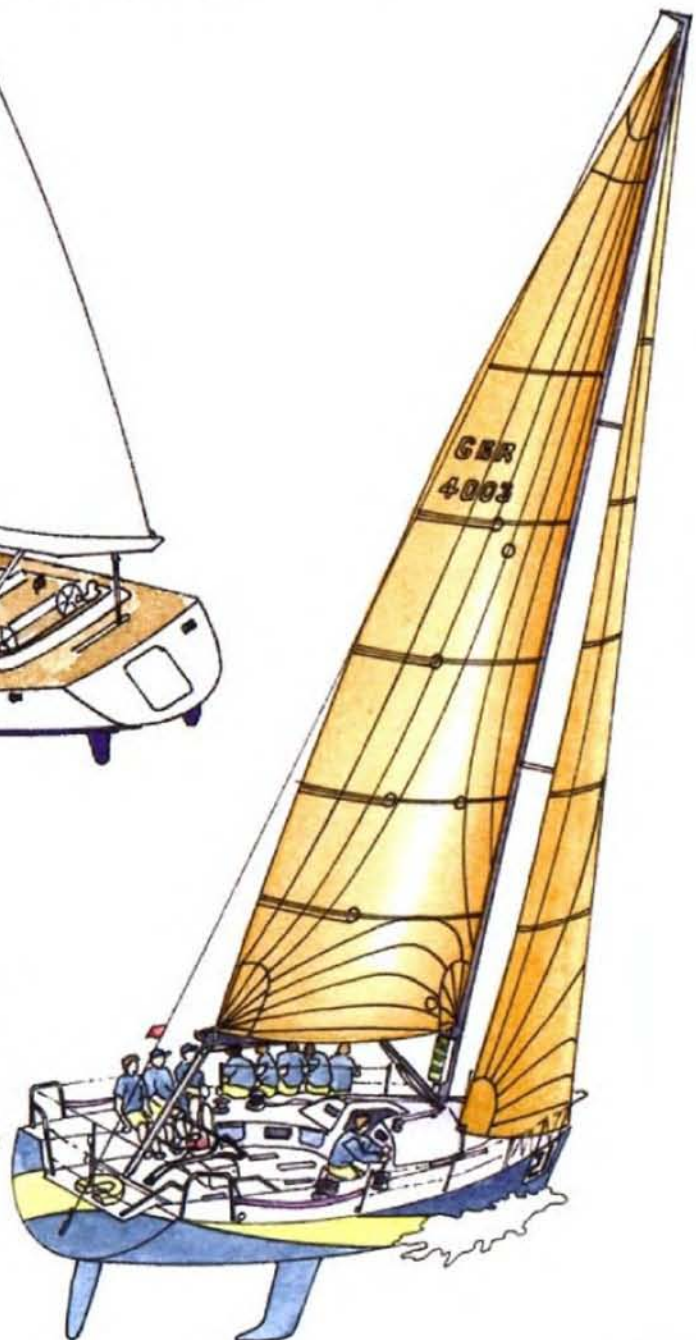

## PARTS OF A SAILING YACHT

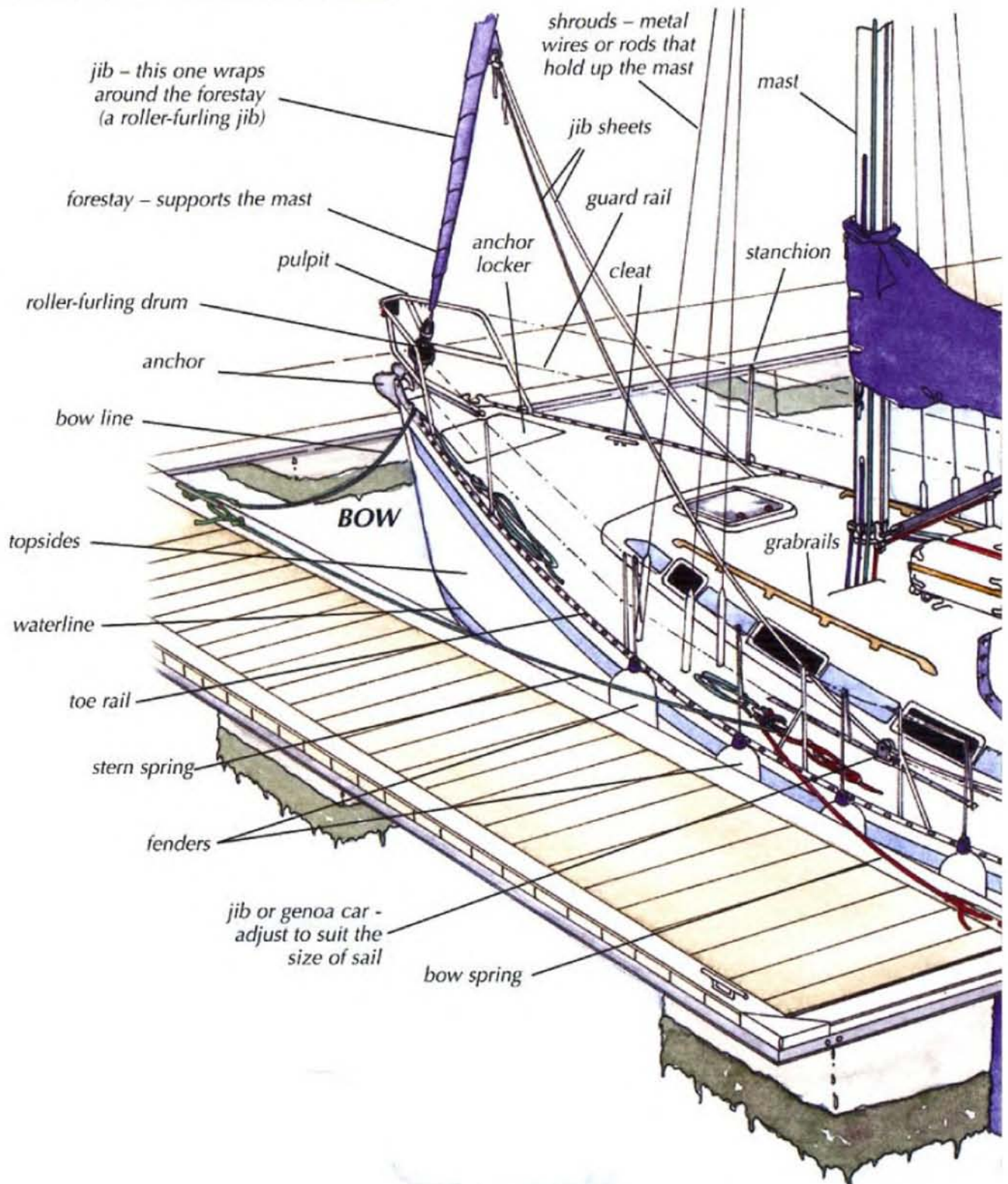

## PARTS OF A SAILING YACHT

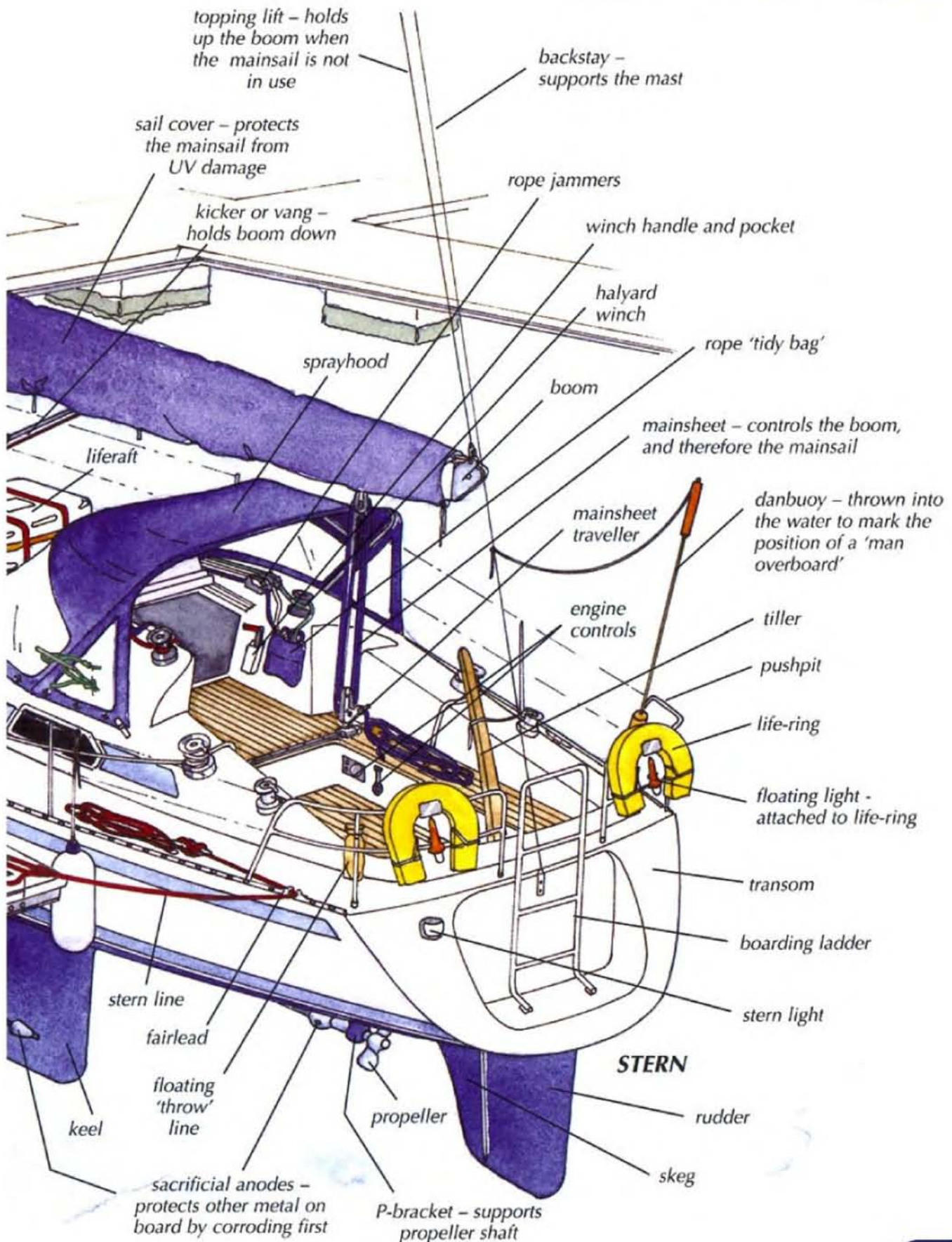

# PARTS OF A SAILING YACHT

## TYPES OF JIB

### Roller-furling

One sail is used for all wind strengths. It can be made smaller when the wind increases by pulling on the furling line from the cockpit. This wraps the sail around the forestay.

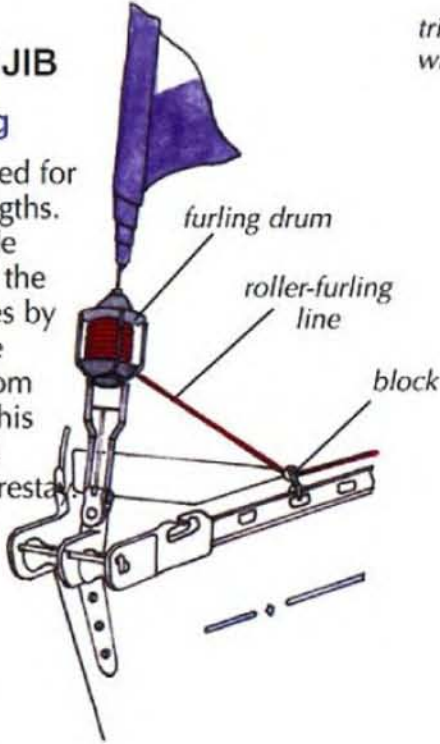

### Hanked on jib

Different size jibs are attached to the forestay by piston hanks. The sail is securely attached to the boat and is less likely to be lost over the side when hoisting or dropping the sail.

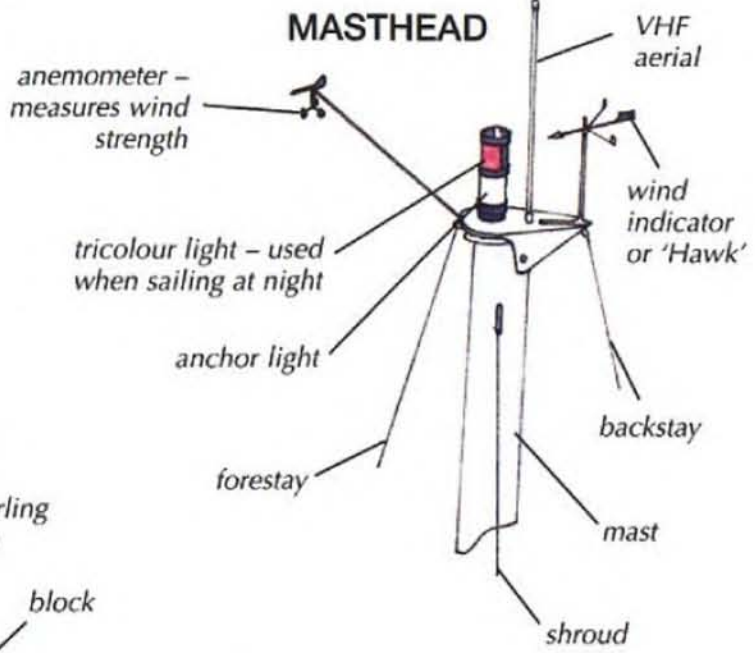
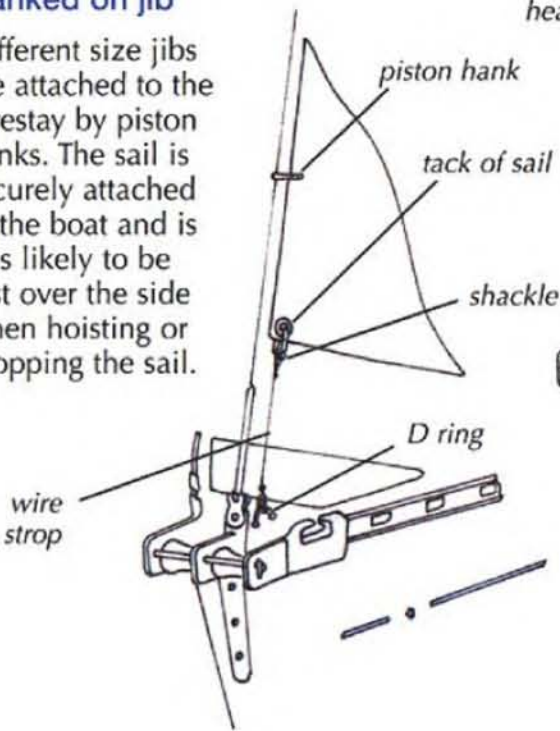

### Luff groove sail

Different size jibs can be fed into grooves in a headfoil. This gives a sail shape that is more aerodynamically efficient.

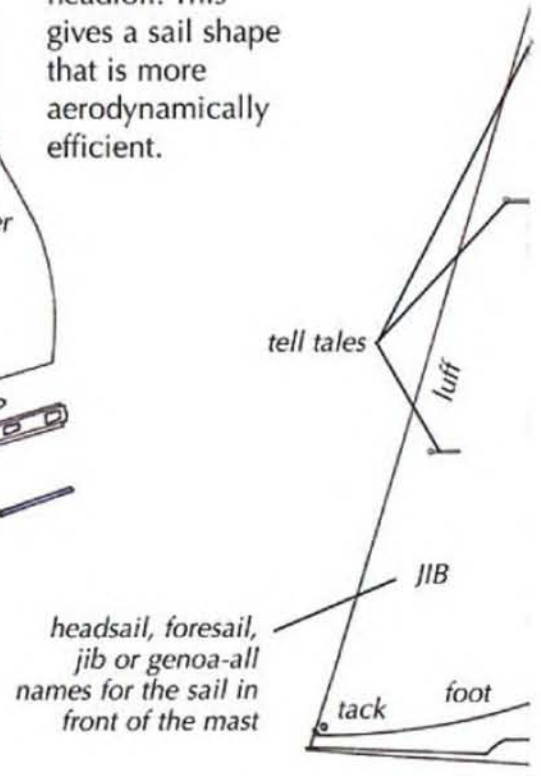
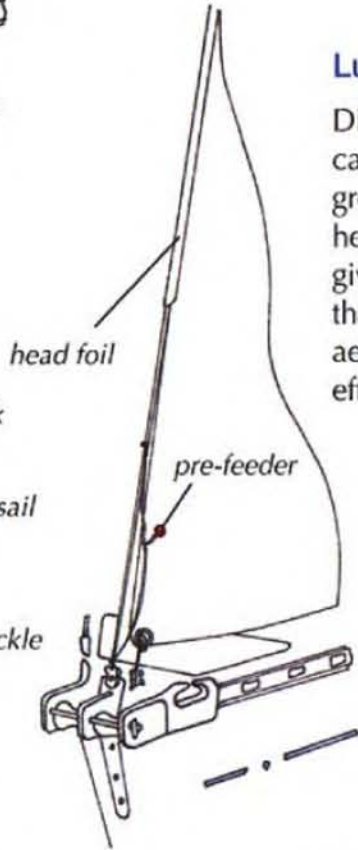

# PARTS OF A SAILING YACHT

## RIGGING AND SAILS

### How a reefing pennant is rigged

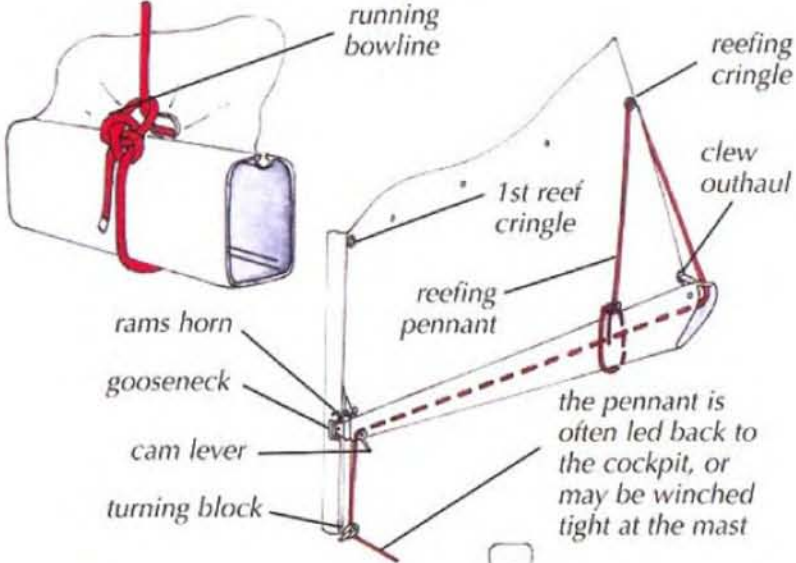

### Typical mainsheet system

The block and tackle arrangement reduces the effort required to pull in the mainsail.

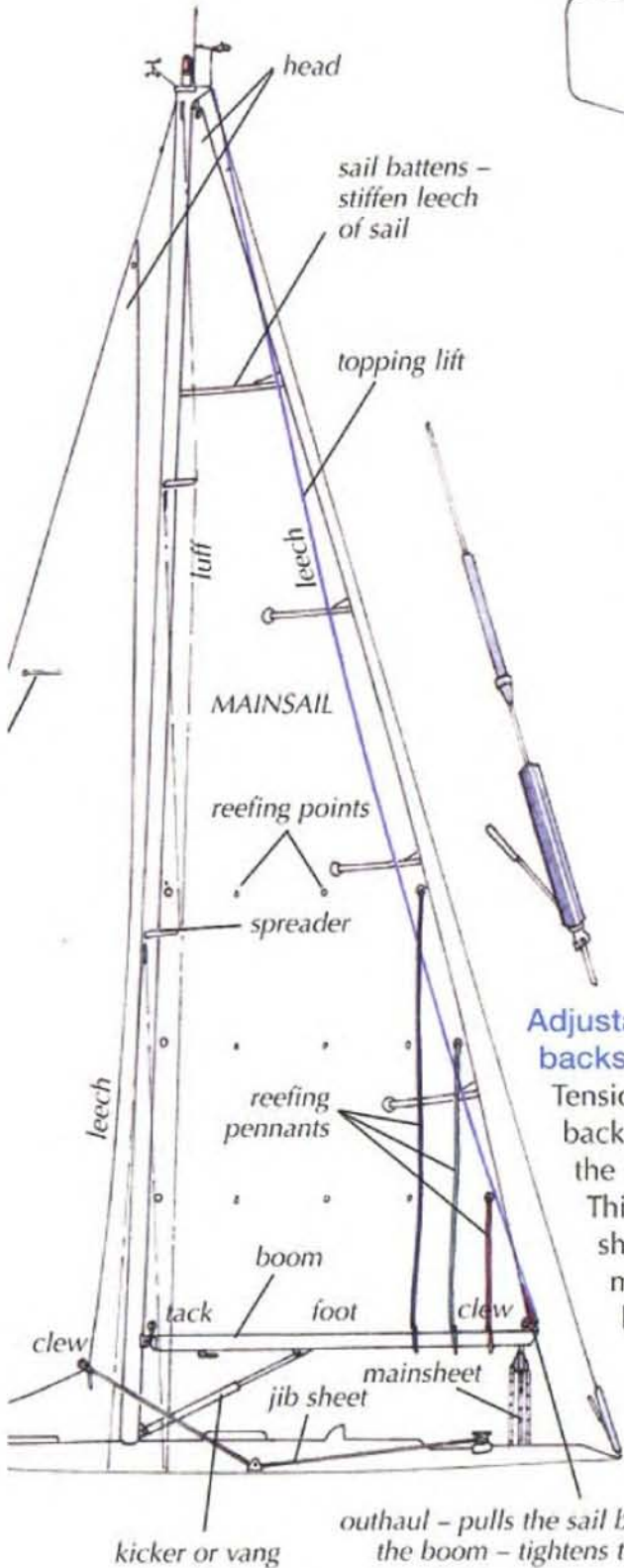
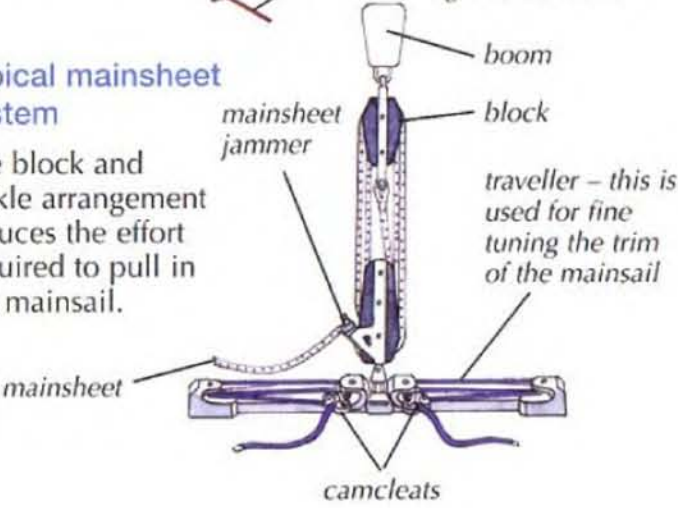

### Adjustable backstay

Tensioning the backstay bends the mast back. This flattens the shape of the mainsail and helps to de-power it in strong winds.

### Kicker or vang

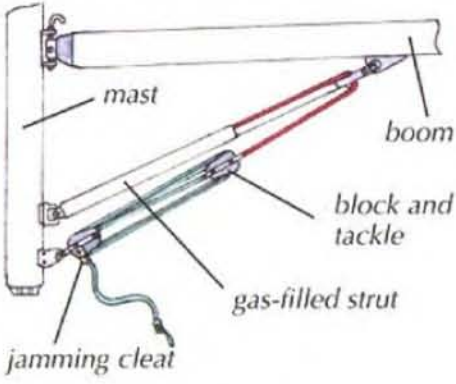

When under sail, the kicker helps to stop the boom and the mainsail from lifting up too much when the wind is from astern.

# KNOTS

## Figure-of-eight

Used as a stopper knot to prevent a rope running through a car or jammer.

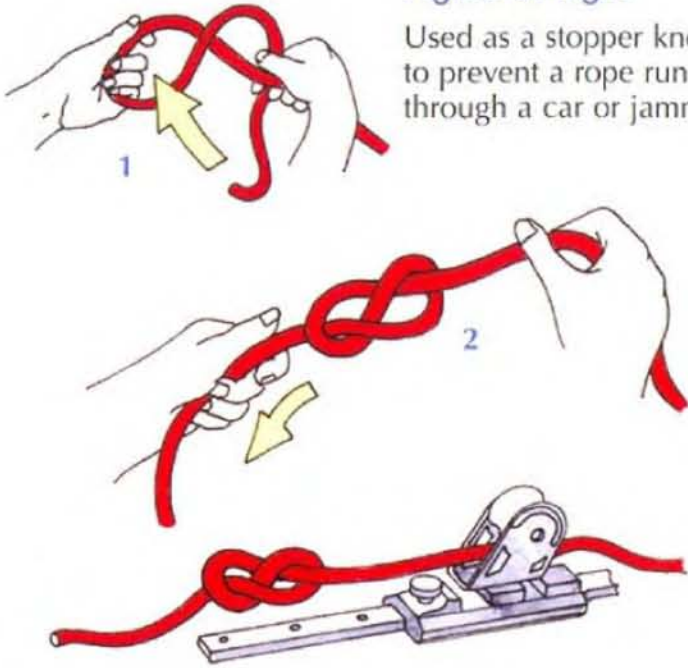

## Clove hitch

For tying on fenders or other uses such as lashing the tiller amidships.

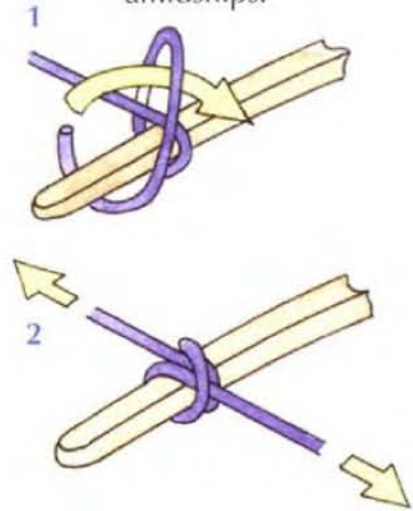

## Rolling hitch

Used for temporarily relieving the strain on a working rope, eg, if you have a riding turn (jam) on a winch.

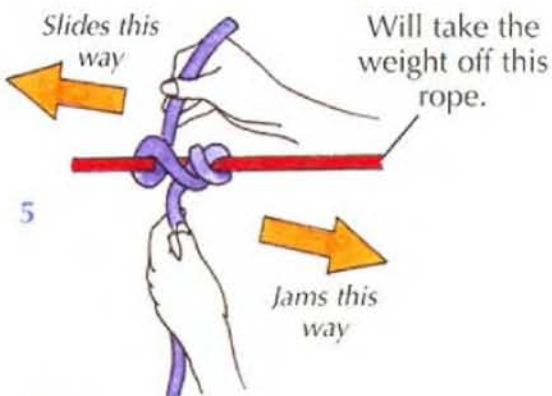
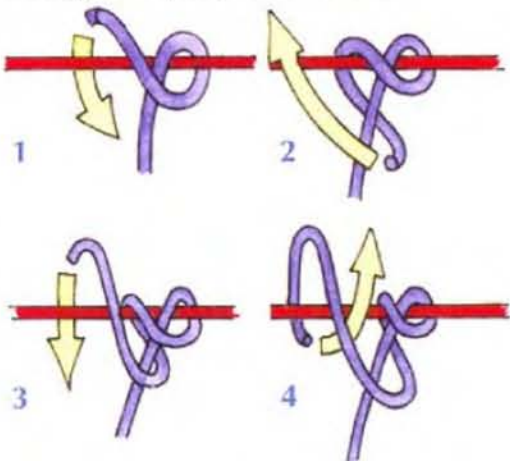

## Bowline

Makes a loop in the end of a rope. Used to attach the jib sheets or to make a loop for mooring.

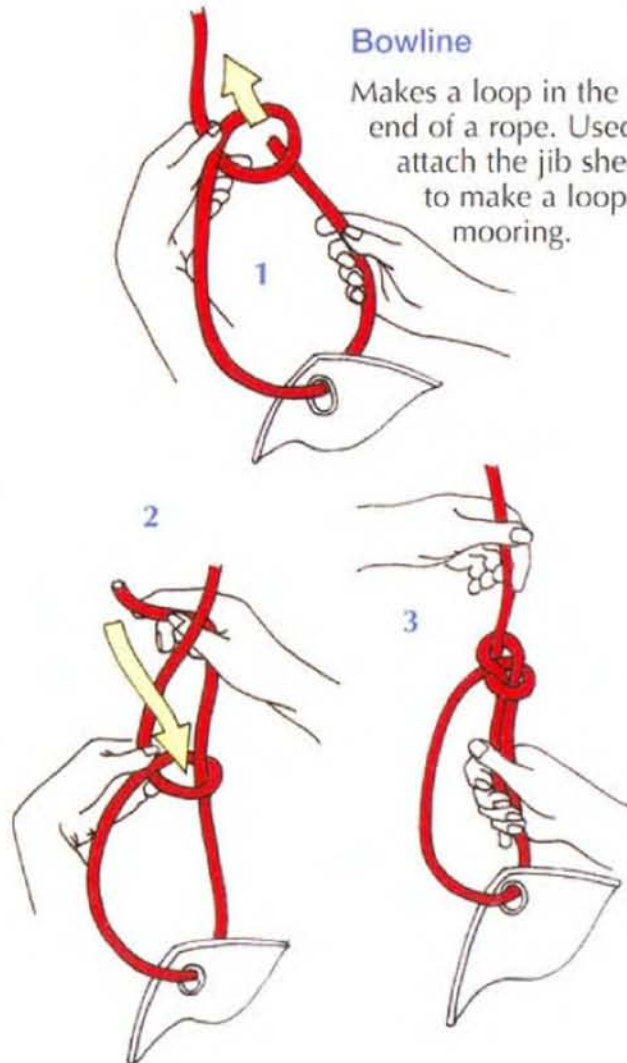

## Round turn and two half-hitches

A versatile knot with many uses such as securing a mooring line to a ring or hanging a fender.

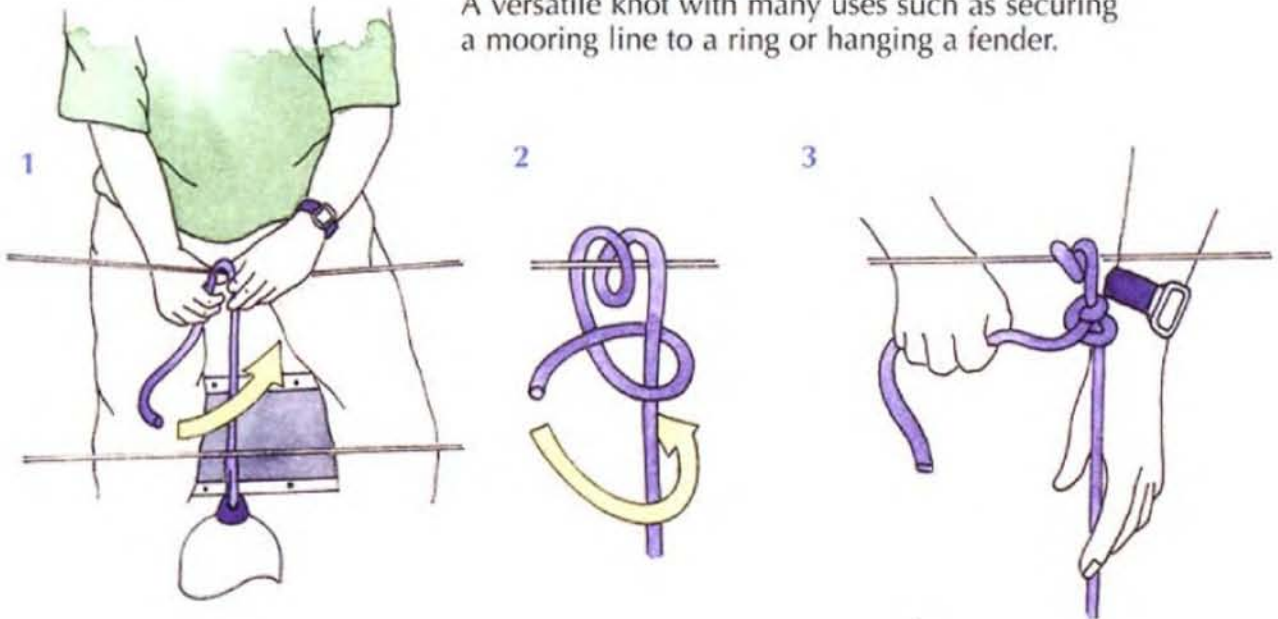

## Single sheet bend

Used to join two ropes – useful to lengthen a mooring line.

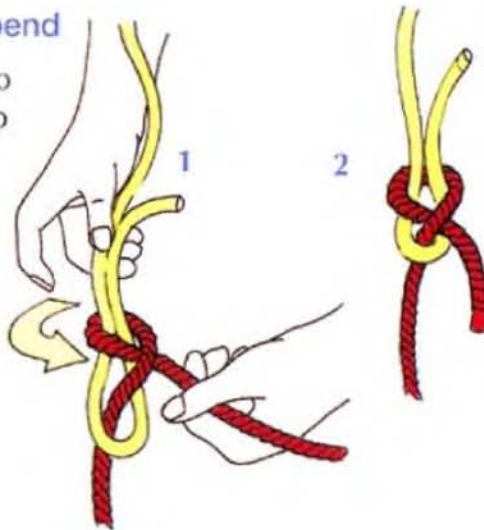

## Double sheet bend

More secure and is also used to tie a smaller line to a larger one.

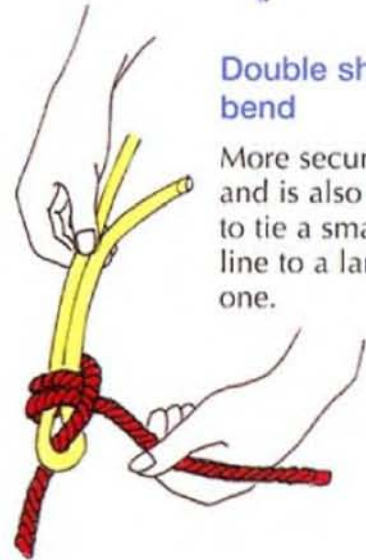

## Reef knot

Useful to tie in reefs to tidy the sail – but not secure enough for mooring lines.

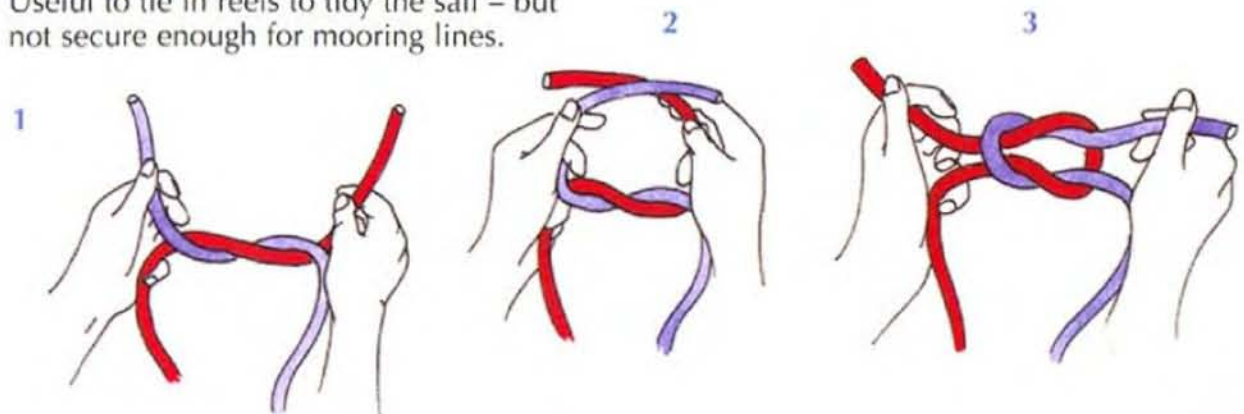



## ROPEWORK



### Making fast to a cleat

Take the rope round the cleat, add one or more figure-of-eights and make another round turn to secure. OXO is a good way to remember this.

Bowline looped through the cleat – easy to release but will not come off accidentally.

Bowlines dipped through and onto the bollard – easy for any vessel to leave.

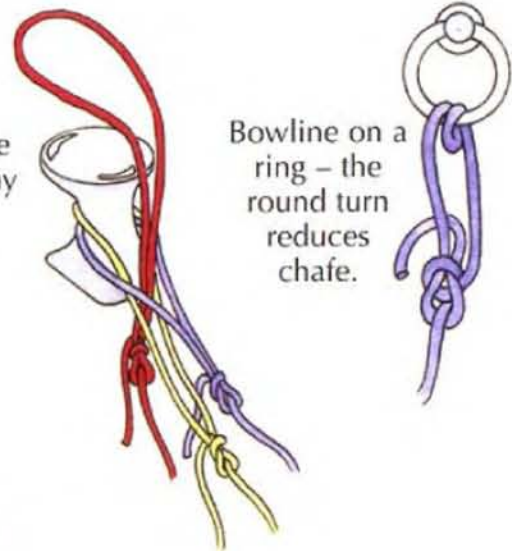

Bowline on a ring – the round turn reduces chafe.

### Coiling a rope

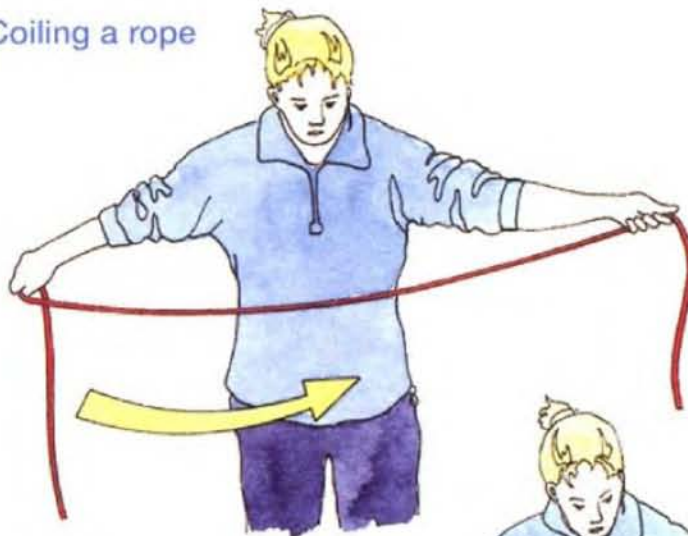

1 Pulling your arms apart the same amount for each coil will help you make even size loops.



2 Coil the rope clockwise into your left hand, and twist your right wrist away from you before you place each loop in your left hand.

## ROPEWORK

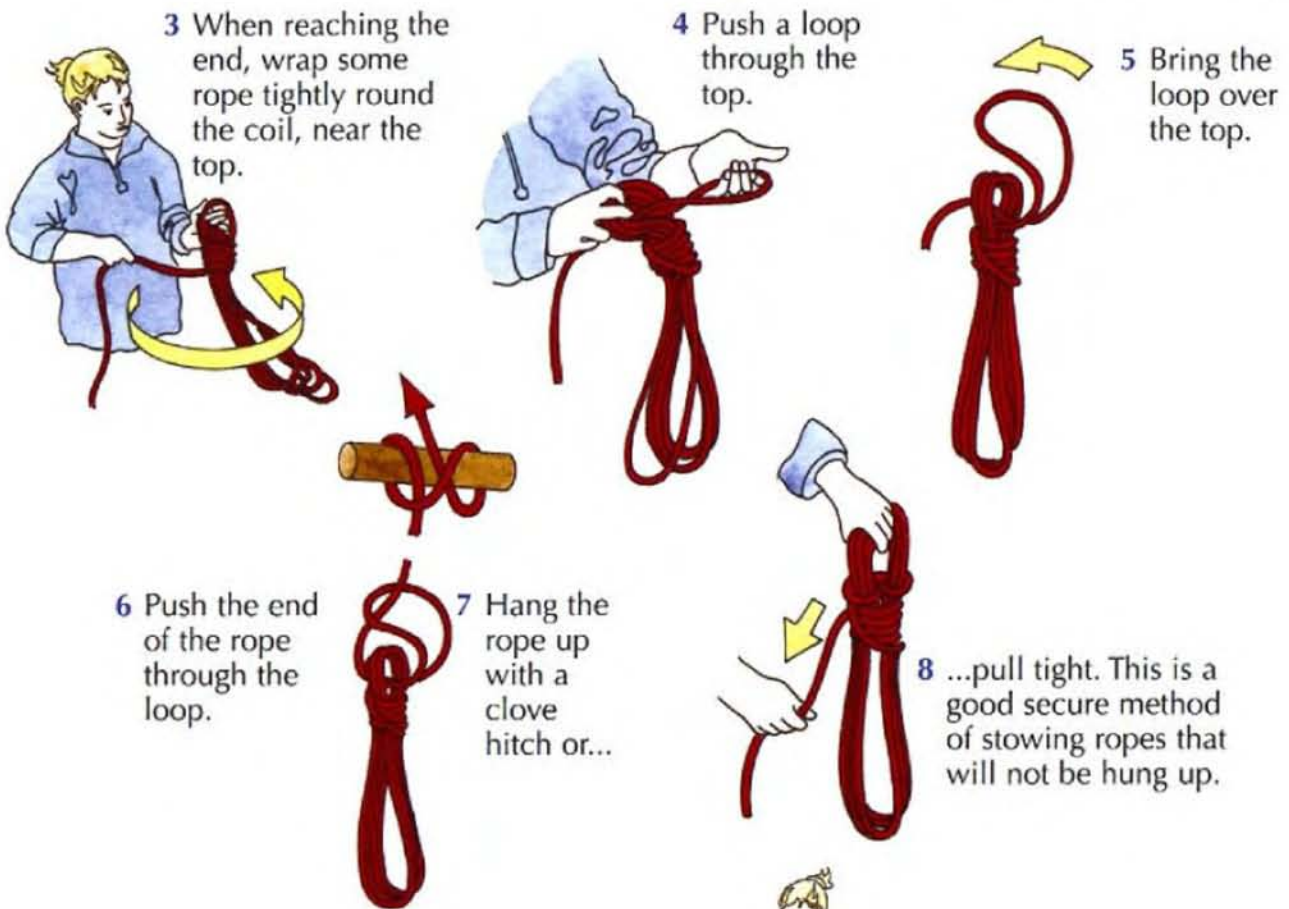

### To secure a halyard on a cleat

Coil the halyard starting at the cleat and work towards the loose end of the rope.

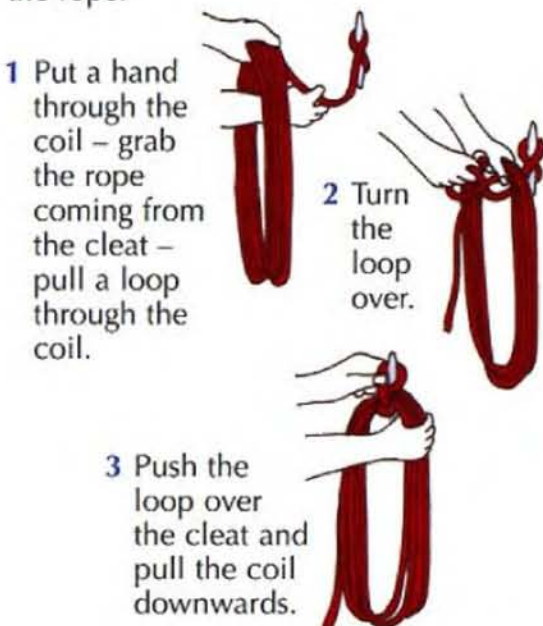

### Before throwing a rope

Split the coil into two with slack between. Throw the first half and release the second immediately after. This will reach the greatest distance and make the rope easier to catch.



# ROPEWORK

## Sweating up a halyard

1 Pull out with the right hand while keeping the rope secure on the cleat with the left hand.



Do not wrap the rope round your hand.

2 Take up the slack with the left hand as you pull down with the right.

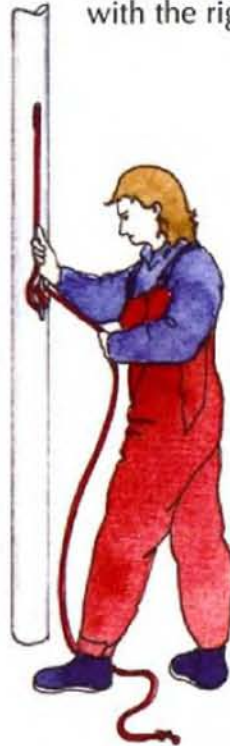

## Using a block with a cam cleat

Pull the rope up to jam it – pull through the jammer to tighten.

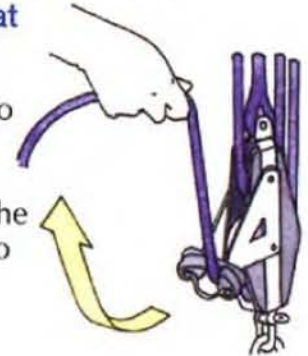

Pull the rope down to release from jammer. You can then ease the rope out.

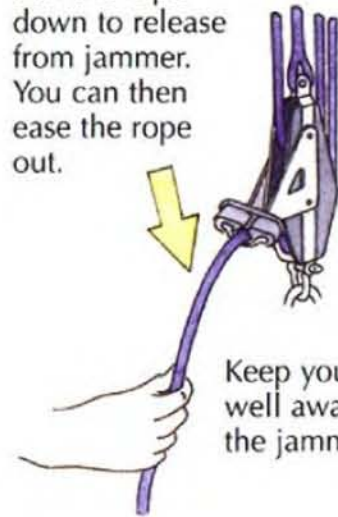

Keep your fingers well away from the jammer.

## Using rope jammers

A rope can be tightened by pulling or winching through a closed jamming cleat.

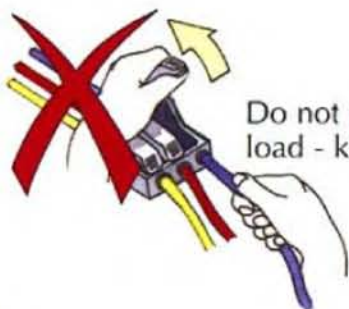

Do not release under load - keep fingers away.

## To release a rope in a jammer

Winch in the rope a little first, then hold the tension on the winch and fully open the jammer.

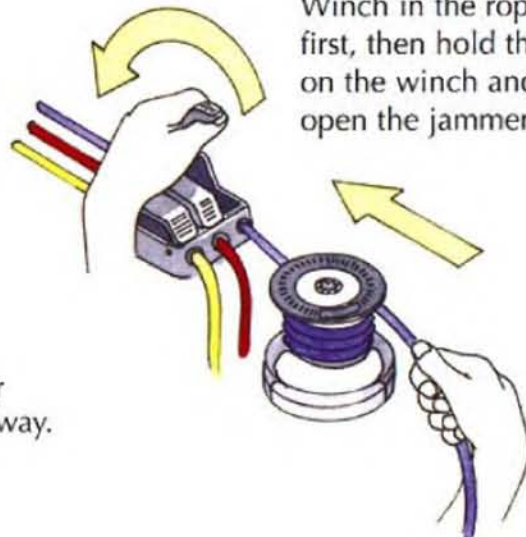

## Using winches

1 Load the rope round the winch clockwise.



2 Keep the tension on and put two turns round the winch. Have your little finger nearest the winch and keep sliding the hand away from the winch.

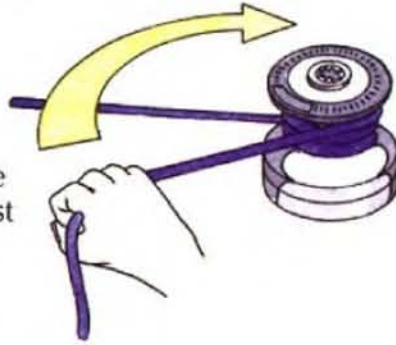

3 Keep the tension on while using the winch handle. Many winches have two gears.

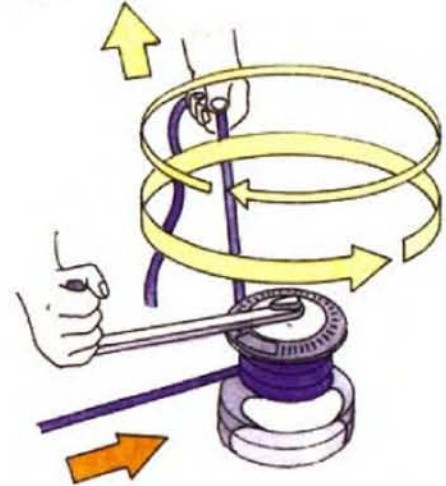

A self-tailing winch holds the rope in a groove at the top.

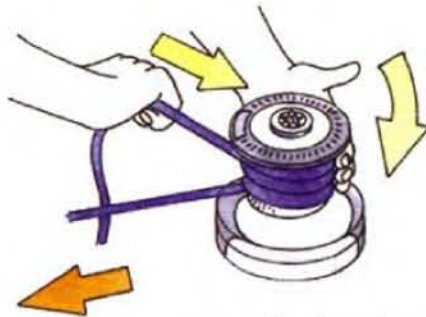

Use a flat hand to ease the rope out.

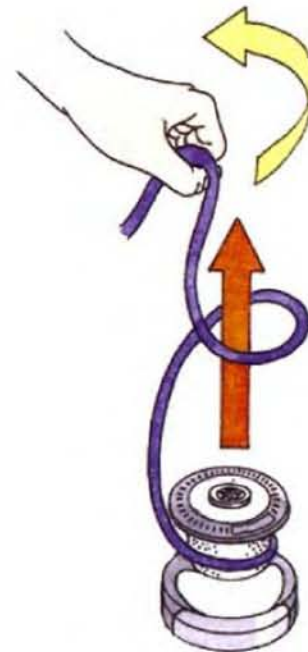

For a fast release – spin the rope vertically upwards to clear the turns off the winch and then let go! Make sure the sheet will run out smoothly.



Crew working together – to provide tension on the sheet – watch the sail and wind the winch.

Never wrap rope round your hand when holding it, pulling on it...or using a winch. Keep hands and fingers away from winches and jammers.

## PREPARING THE SAILS FOR SEA

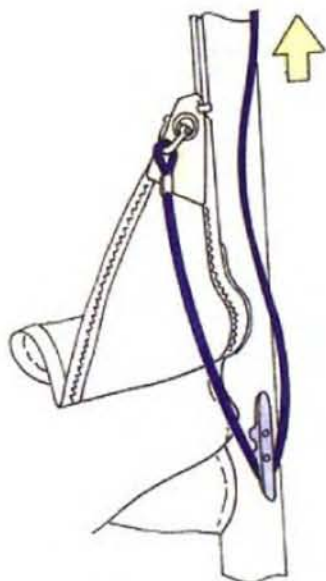

- 3 Loop the halyard round a cleat and pull tight so the sail is ready to go up but is secure. (Don't do this with a wire halyard as it may damage the halyard, the cleat and the mast.)



- 4 Undo the coils of the mainsheet but keep it jammed tight until the crew have finished working around the boom.

Most skippers motor out of the marina and harbour but will always have the sails ready for use.

- The engine may stop unexpectedly
- It's easier to get everything ready in the shelter of harbour

### Main

- 1 Take off the mainsail cover. Fold and stow it.
- 2 Attach the main halyard making sure it is led from the masthead to the head of the sail correctly – not around the rigging.

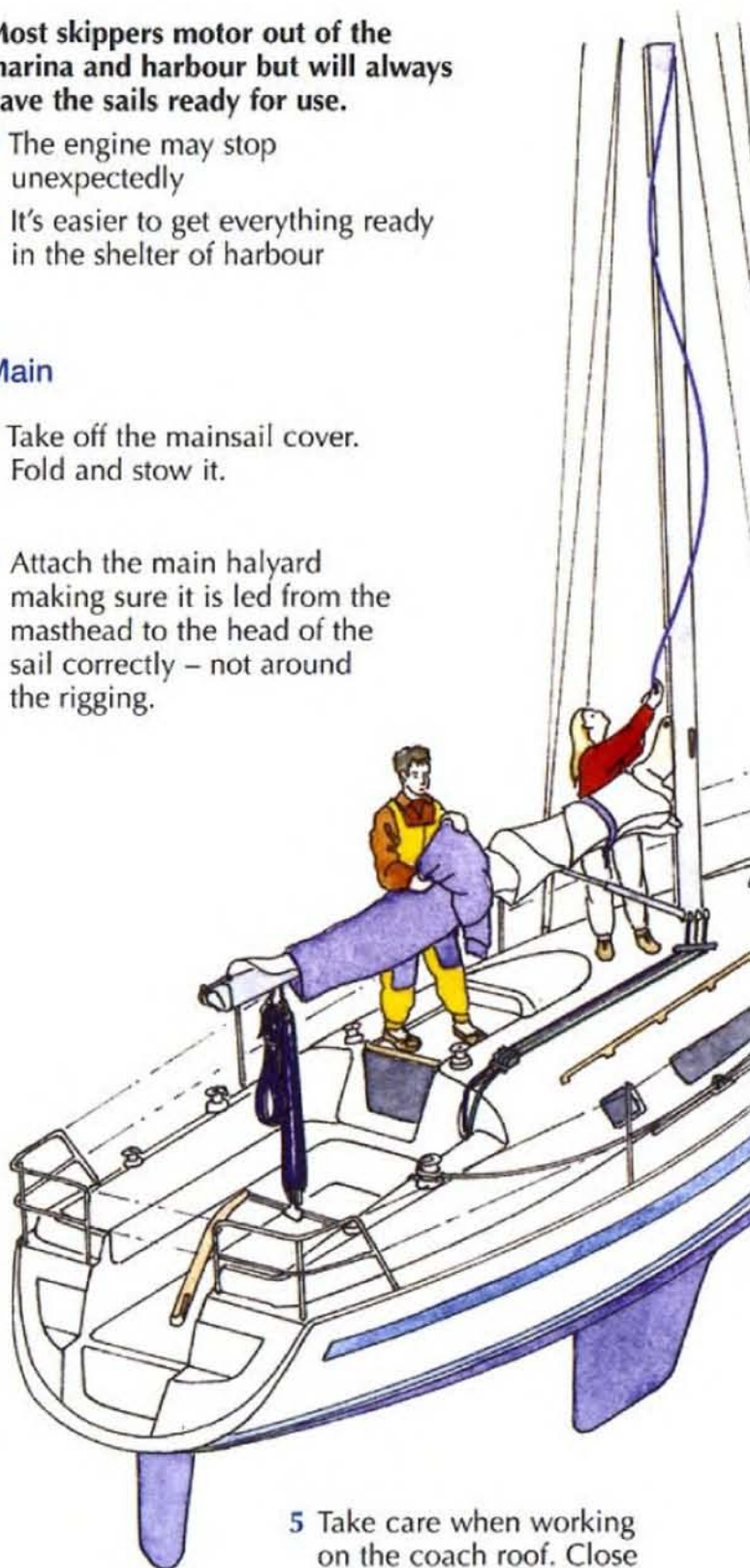

- 5 Take care when working on the coach roof. Close the main hatch to avoid falling down the companionway.

**Jib**

- Attach the tack of the sail to the D ring and hank the sail to the forestay
- Clip the halyard to the head of the sail and to the pulpit
- Tie the sheets to the clew of the sail and lead them back to the cockpit correctly
- Add a figure-of-eight knot to the end of the sheets
- Move the sheet cars on both side decks to the correct position
- Secure the sail neatly to the top guard rail

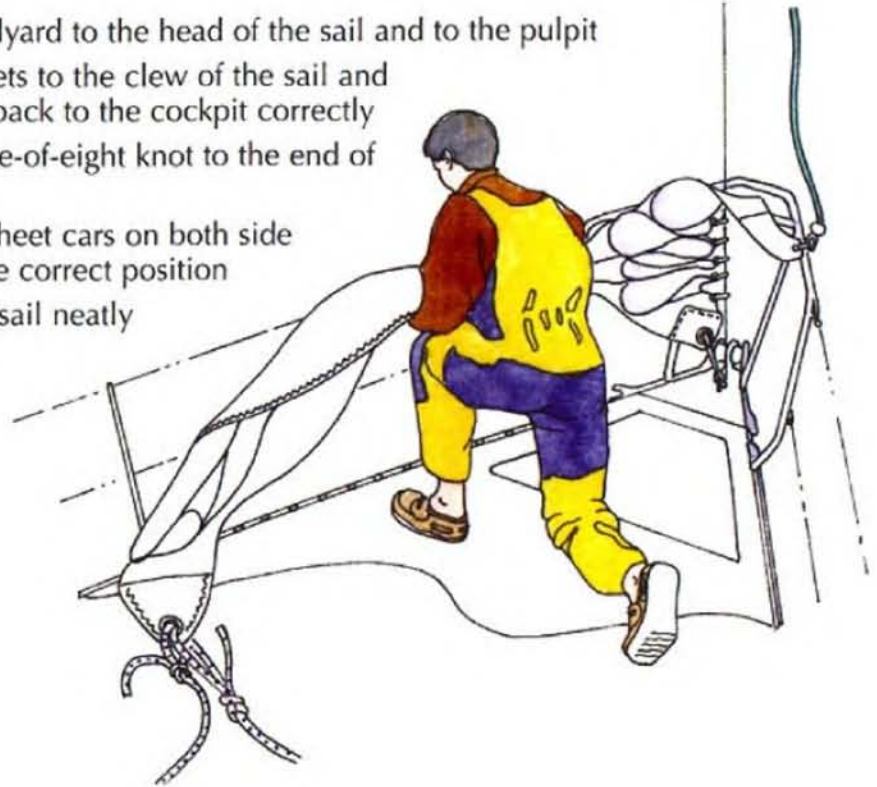
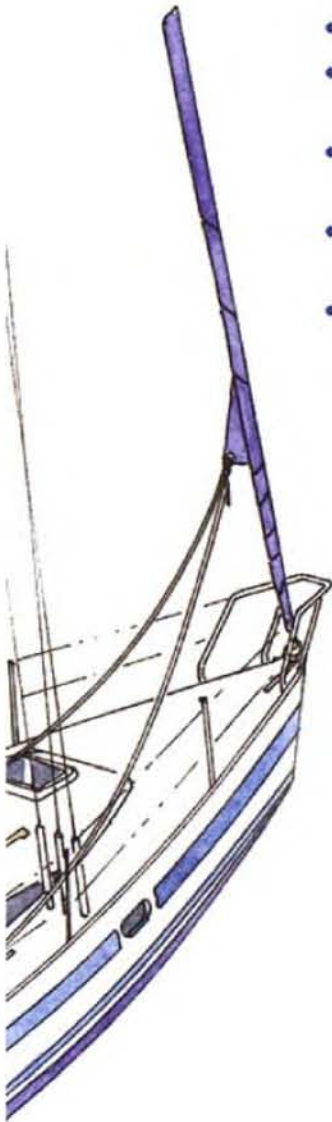

**Headfoil**

Sail stowed on deck ready to be fed into the groove on the head foil, secured at the tack, sheets tied on and led back to the cockpit ready for use.

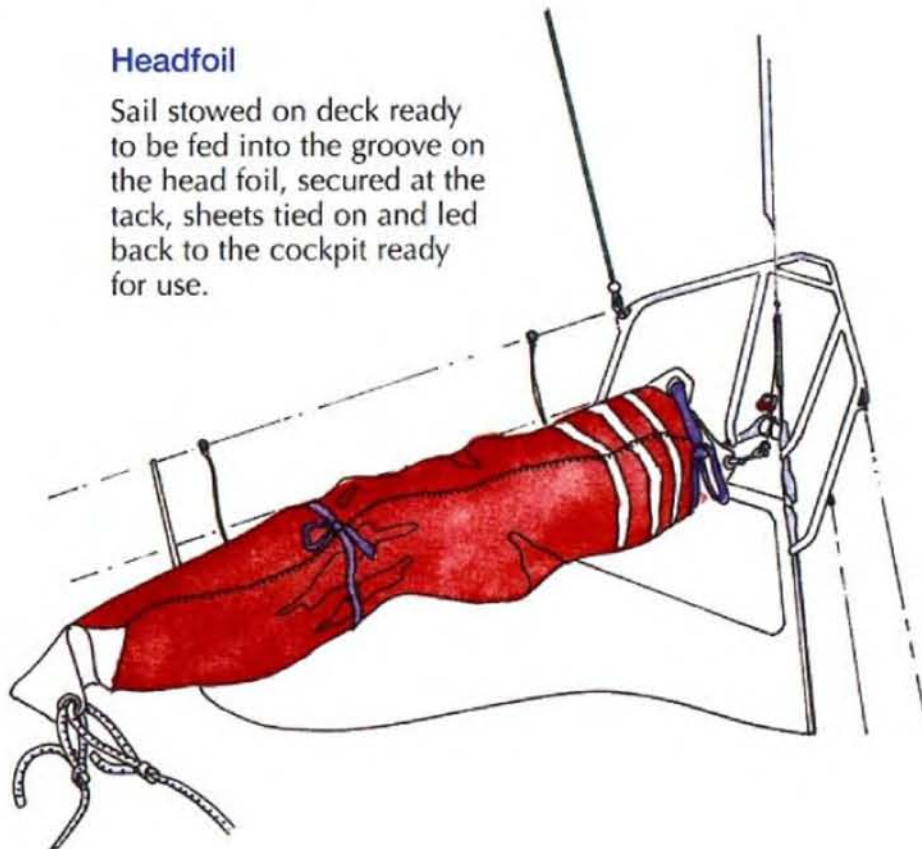

## HOISTING THE MAINSAIL

1 Remove the sail ties.

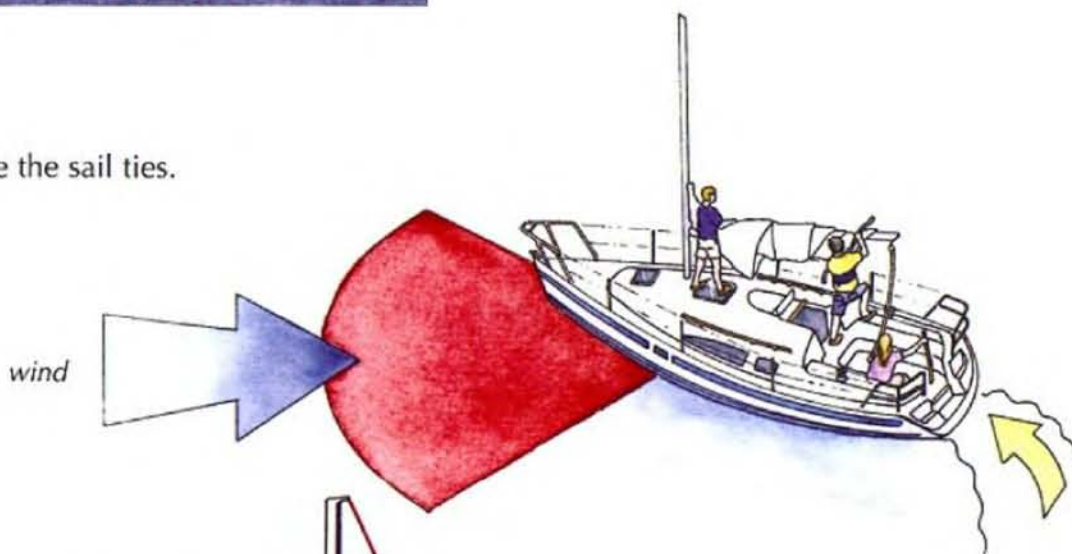

2 Head the boat close to the wind but not straight into it. The mainsail will flap as it is raised and the boom will be to one side of the cockpit – away from the crew winching the halyard.

3 Position the crew in front of the mast or in the cockpit – clear of the boom.

4 Release the mainsheet and the kicking strap when the crew are clear.

5 Free the main halyard and pull it 'out and down' at the mast, while taking up the slack through an open jammer in the cockpit.

6 Watch the sail for any jams as it goes up. Check that it is flapping all the time.

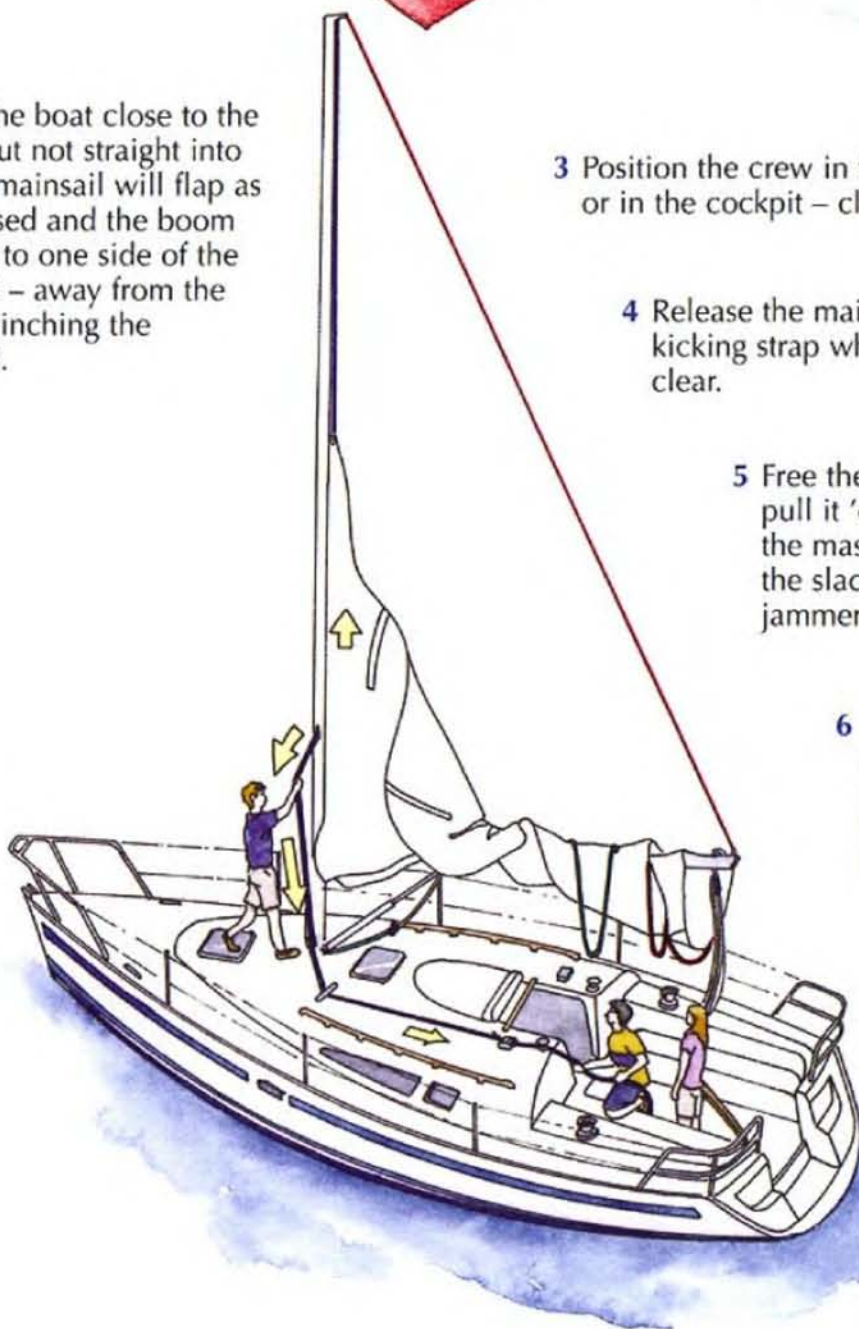

# HOISTING THE MAINSAIL

Too little halyard tension.

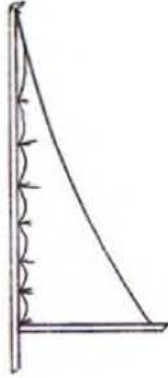

Too much halyard tension.

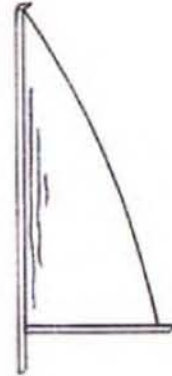

The topping lift should be just slack when the mainsheet is at its tightest.

8 Pull in the mainsheet and ease the topping lift.

7 Close the jammer and pull the halyard while winding the winch. Watch the luff of the sail to get the correct tension.

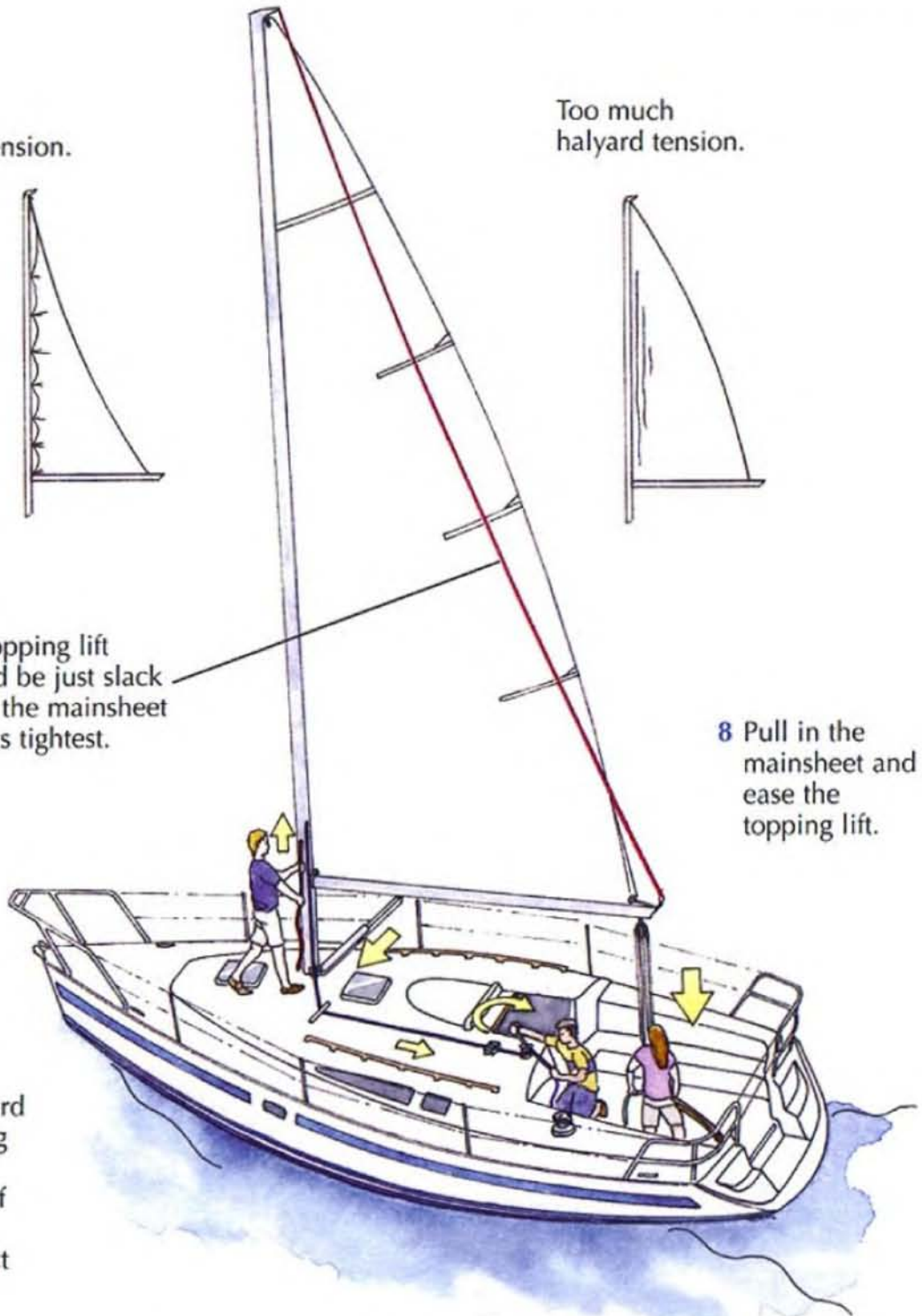

9 Tighten the kicking strap, check the outhaul and stow the halyard.

10 The helm can now bear away from the wind and sail!

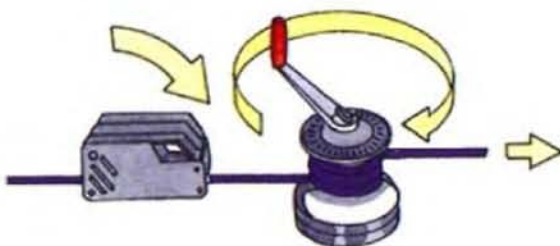



## HOISTING THE JIB

### A roller-furling jib

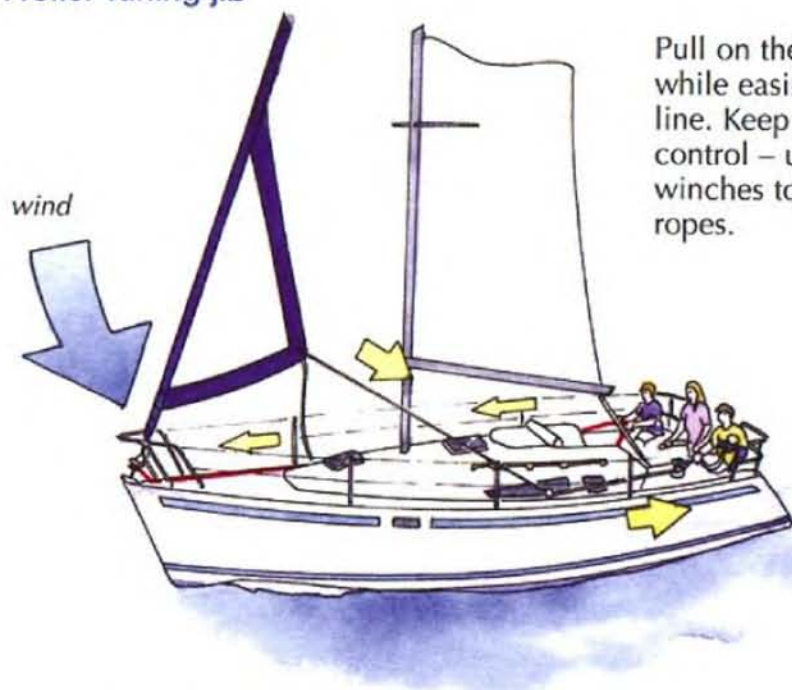

Pull on the leeward sheet while easing out the furling line. Keep the sail under control – use cleats and winches to control the ropes.

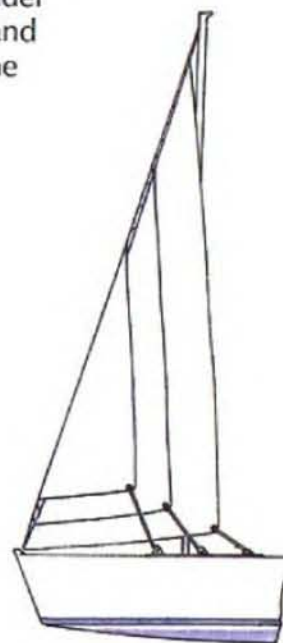

With a small sail, move the genoa car forward to put equal tension on the leech and foot.

Not all of the sail needs to be unfurled every time. In windy conditions keep the jib smaller.

### A hanked-on foresail

- 1 Make the sail ready to go – remove ties and release the halyard.
- 2 Release the sheet.
- 3 Pull the halyard 'out and down' at the mast while taking up the slack through an open jammer in the cockpit.
- 4 Watch the sail does not snag as it goes up.
- 5 Close the jammer, pull the halyard while winding the winch. Watch the luff of the sail to get the correct tension.

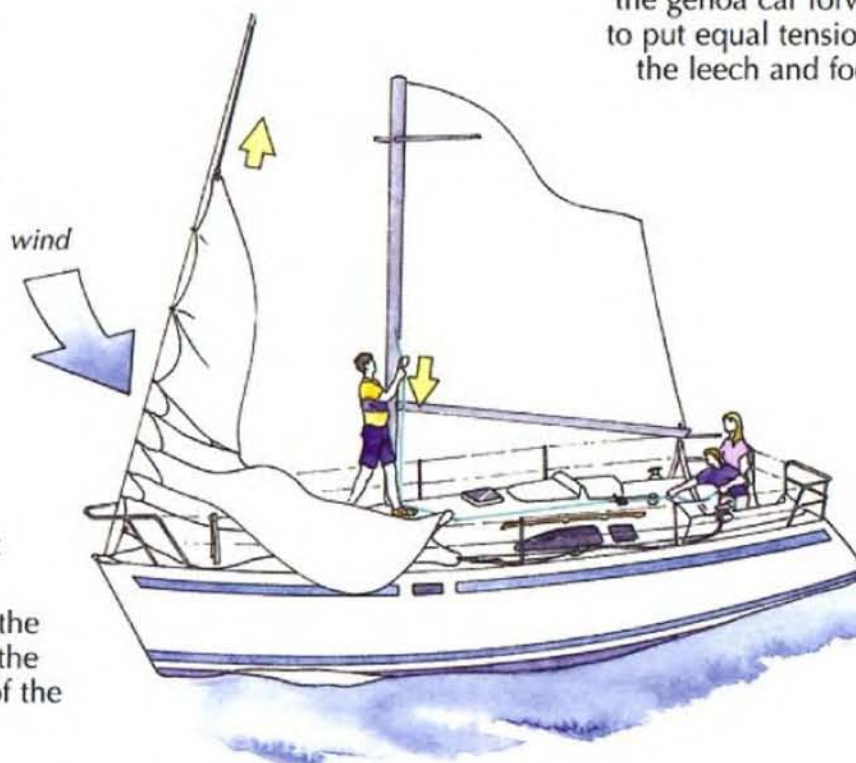

- 6 Pull in and winch tight the sheet on the leeward side to the correct tension – and sail!

# HOISTING THE JIB

A loose-luffed jib



1 Feed the head into the luff groove, attach the halyard and release the ties.

2 Feed the luff of the sail into the groove while the halyard is slowly pulled to raise the sail. Watch for snags as it goes up and make sure it stays in the pre-feeder.



Set the halyard tension then pull in the sheets – jib then main – no more than is necessary to stop them flapping.

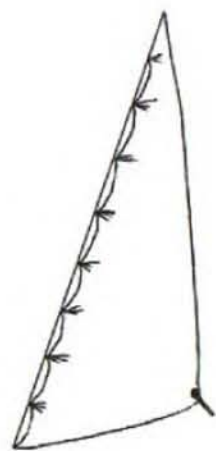

Too little halyard tension.

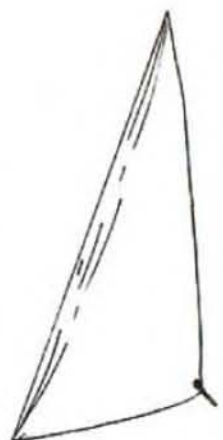

Too much halyard tension.

## REEFING THE MAINSAIL

### TOO MUCH SAIL ON A WINDY DAY

- Makes the boat difficult to steer straight – the wheel or tiller is too heavy
- Causes the boat to heel (lean over) excessively



- Makes the boat lose speed
- Gives the boat a tendency to broach in gusts – heel suddenly and uncontrollably and head towards the wind – this can be alarming and sometimes dangerous - it's time to put a reef in

### Reefing

- 1 Send the crew to the mast wearing a harness.
- 2 Head the boat close to, but not straight into the wind.
- 3 Ease out the kicking strap then the mainsheet.
- 4 Pull up on the topping lift to raise the boom and depower the sail.

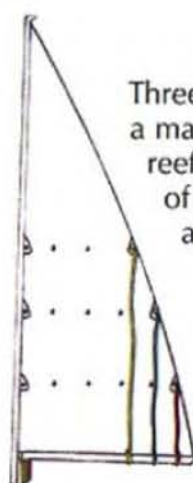

### Trisail

A very small strong sail rigged instead of the main in very strong winds.

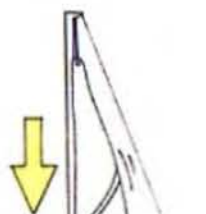
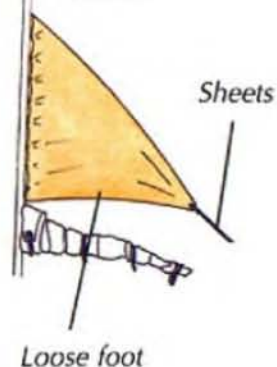

There are several other methods of reefing, depending on how a boat is rigged. Slab reefing, shown here, is one of the most common.

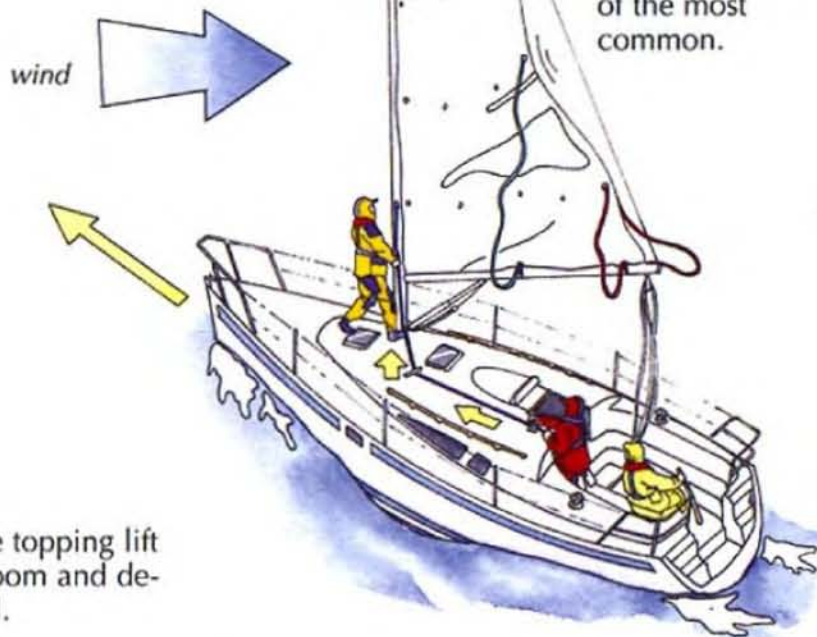

- 5 With the mainsail flapping, lift the jammer and ease the halyard. Pull the sail down and hook the cringle in the luff of the sail over the rams horn and hold it in position.

## REEFING THE MAINSAIL

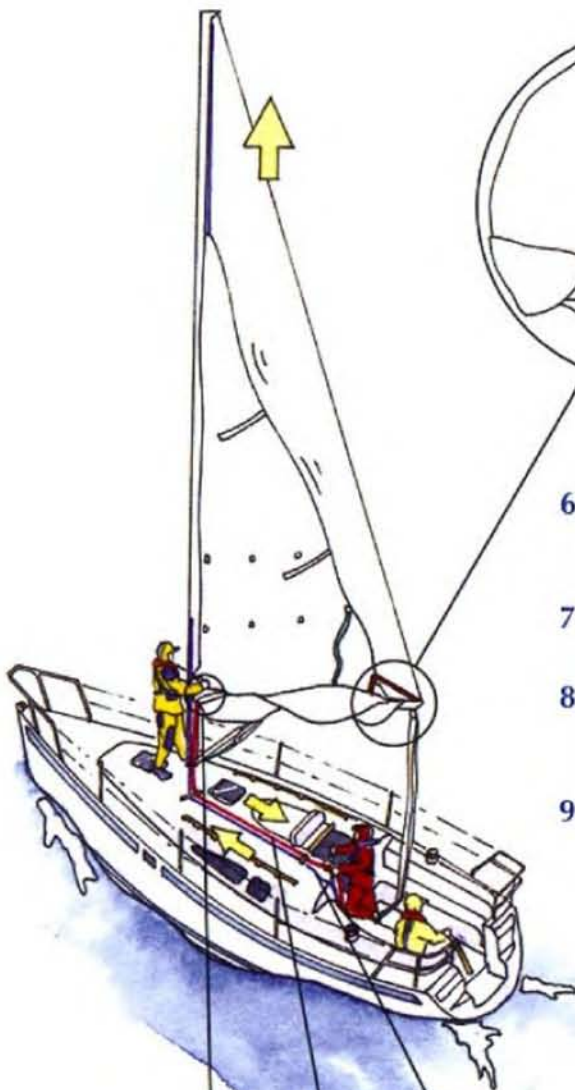

While the reefing pennant is being winched tight the sail must be flapping. Watch for jams.

- 6 Shut the jammer and winch the halyard tight again.
- 7 Winch the reefing pennant tight.
- 8 Ease the topping lift and pull in the mainsheet and kicking strap.
- 9 Pull in the slack in the other reefing pennant and tidy all lines.

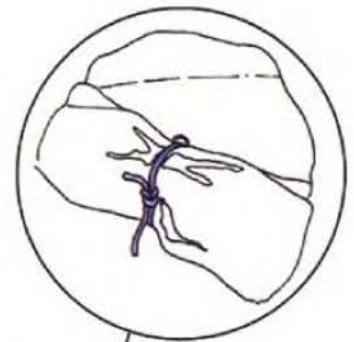

- 10 Use reef knots to tidy the sail onto the boom with the sail ties – but not tight enough to strain the sail.

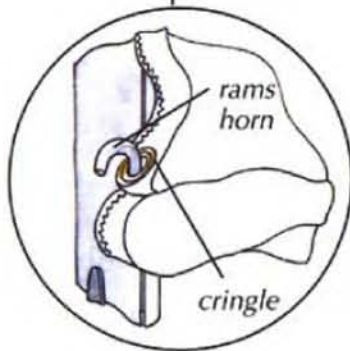

reefing line  
(red)

halyard  
(blue)

rams  
horn

cringle

Sails now balanced in size – boat sails straight, fast and comfortably.

## CHANGING THE HEADSAIL

### Roller-furling jib

Pull on the furling line to rotate the forestay and furl the jib. Ease out the sheet, keeping it under tension to ensure a smooth furl.

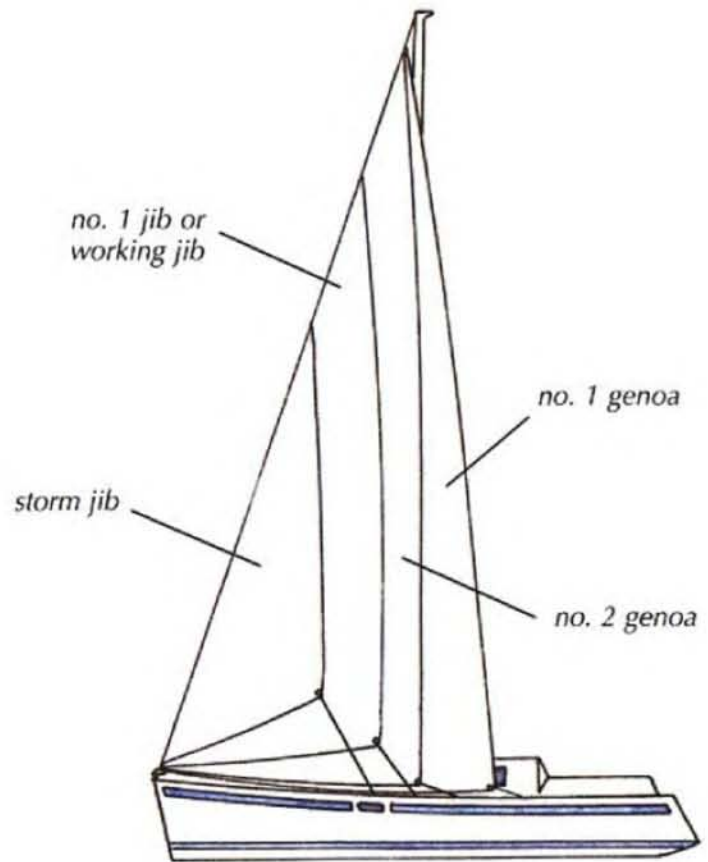
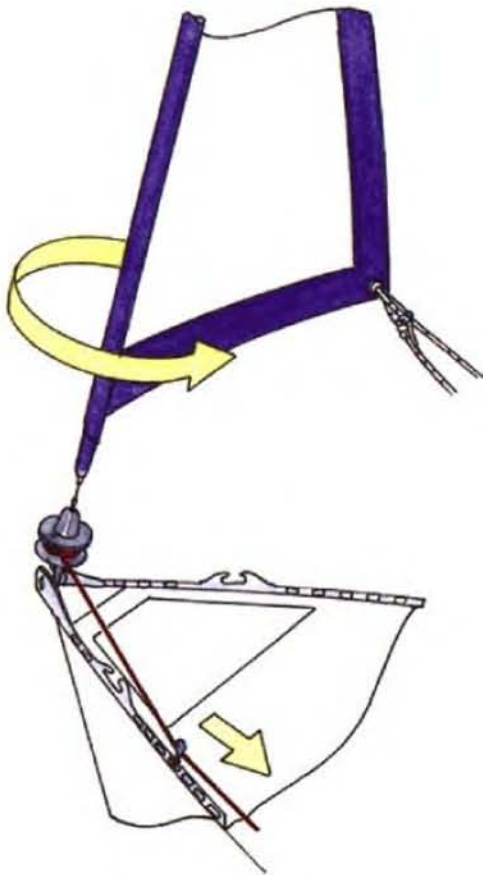

When you change the size of the headsail you will need to change the position of the car as well.

### Hanked-on jib

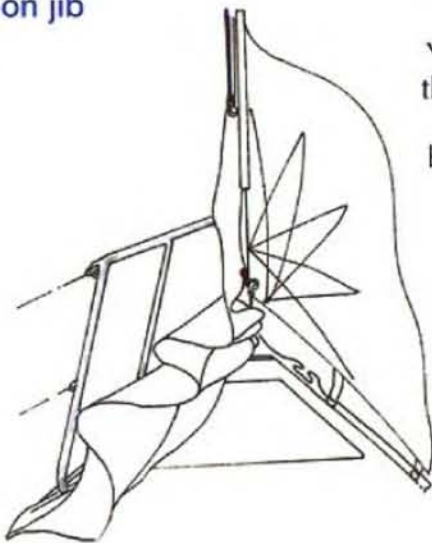

You can prepare the new headsail for hoisting before you drop the old one.

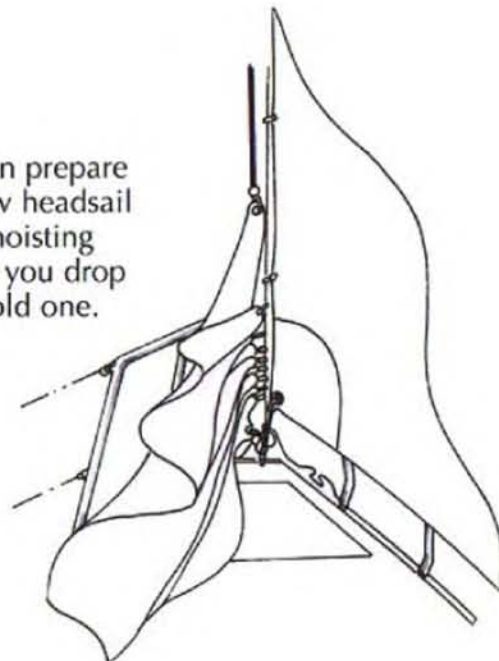

## CHANGING THE HEADSAIL

### Dropping the headsail

- 1 Ease out the halyard.
- 2 Pull down on the luff of the sail – keep some tension on the jib sheet – so neither the sail nor the sheet go over the side.



Large headsails may need two people on the foredeck to control the sail.

- 3 Remove the halyard from the sail and clip it onto the pulpit – re-tension the halyard.
- 4 Pull the sail back and roll it so it can be tied to the guard rail to use again.

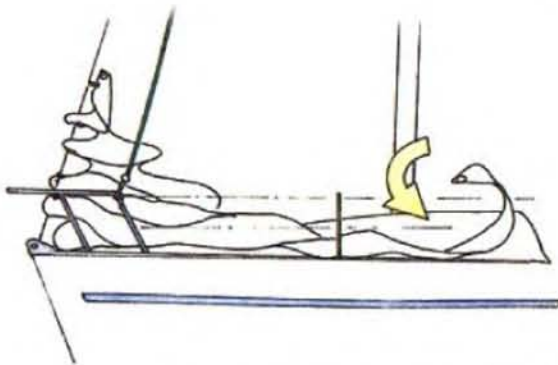
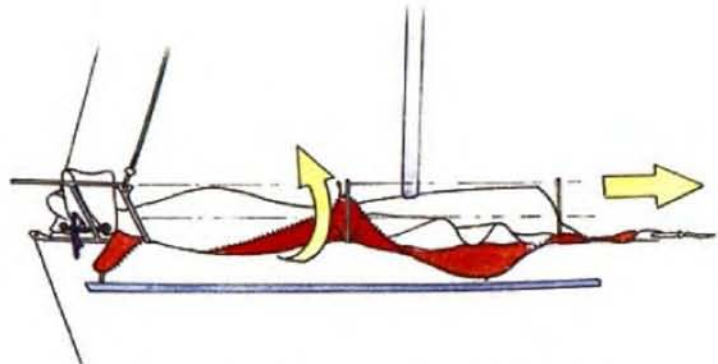

- 5 Or if not required again, fold it from the clew forward. Remove the hanks and stuff it into its sailbag.

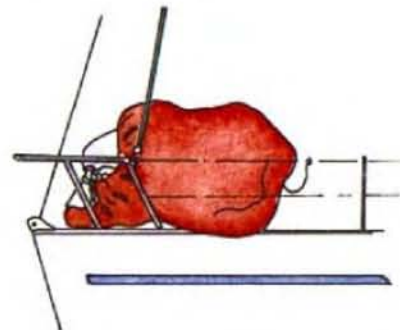

- 6 Keep the bag and sail tied in place!

- 7 Coil up and tidy away all sheets and the halyard.

## STOWING THE MAINSAIL

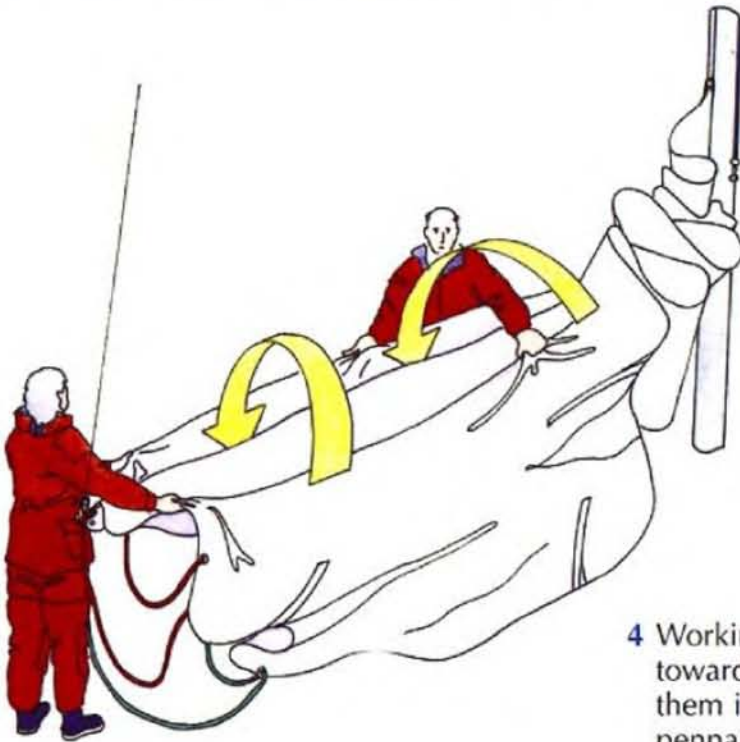

### Bagging the mainsail

- 1 Check the mainsheet and topping lift are tensioned and secure. Close the main hatch before working beside the boom.
- 2 Push all the sail to one side of the boom – the leeward side is easiest.
- 3 With crew at either end of the boom, make a bag of sail on the windward side of the boom.
- 4 Working together, grab folds of sail – pull towards the back of the boom and push them into the bag. Lift in the slack reefing pennants too.
- 5 Keep working until all the sail is in the bag – roll the bag tight and lift it onto the top of the boom. Secure with sail ties.

### Flaking the mainsail

- 1 Push all the sail to one side of the boom - leeward side is easier.
- 2 With crew at either end of the boom, flake the sail from one side of the boom to the other in even-sized folds – keep pulling the sail towards the stern to keep it flat.
- 3 Hold the sail in place with the sail ties – secure the head of the sail.

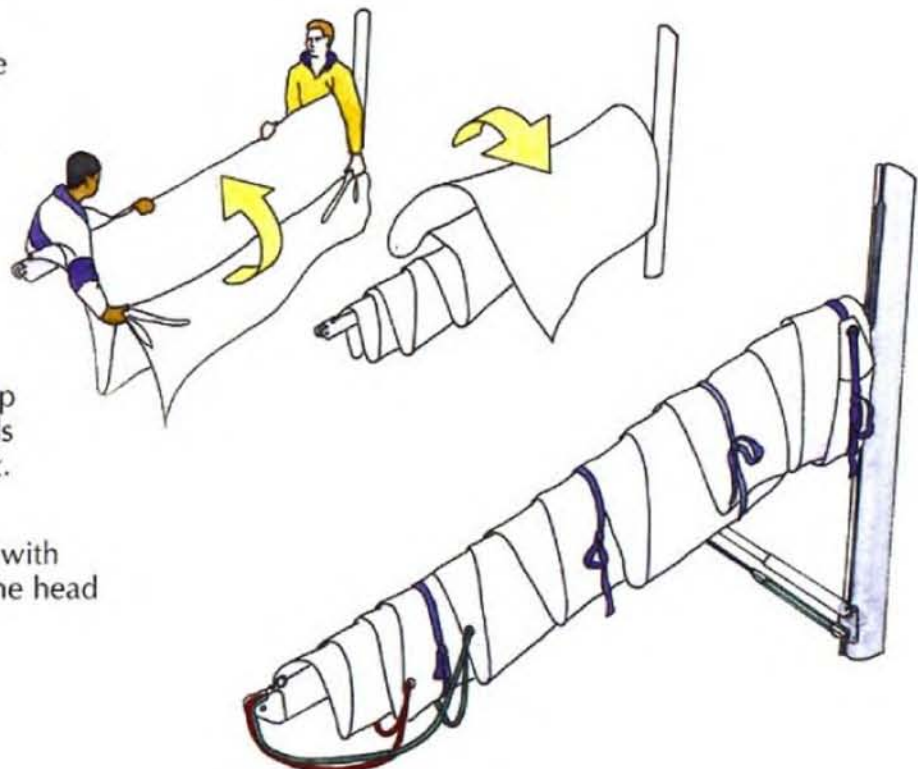

## STOWING THE JIB

### Flaking and bagging the jib

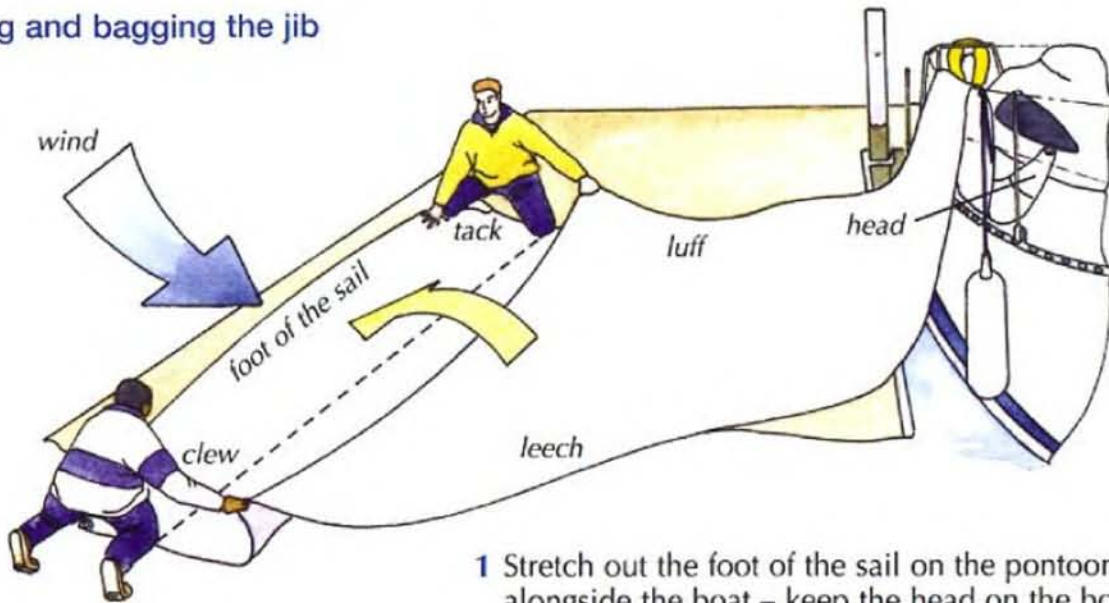

2 Kneel on the sail, and working together grab a fold of sail and place it on top of the foot.

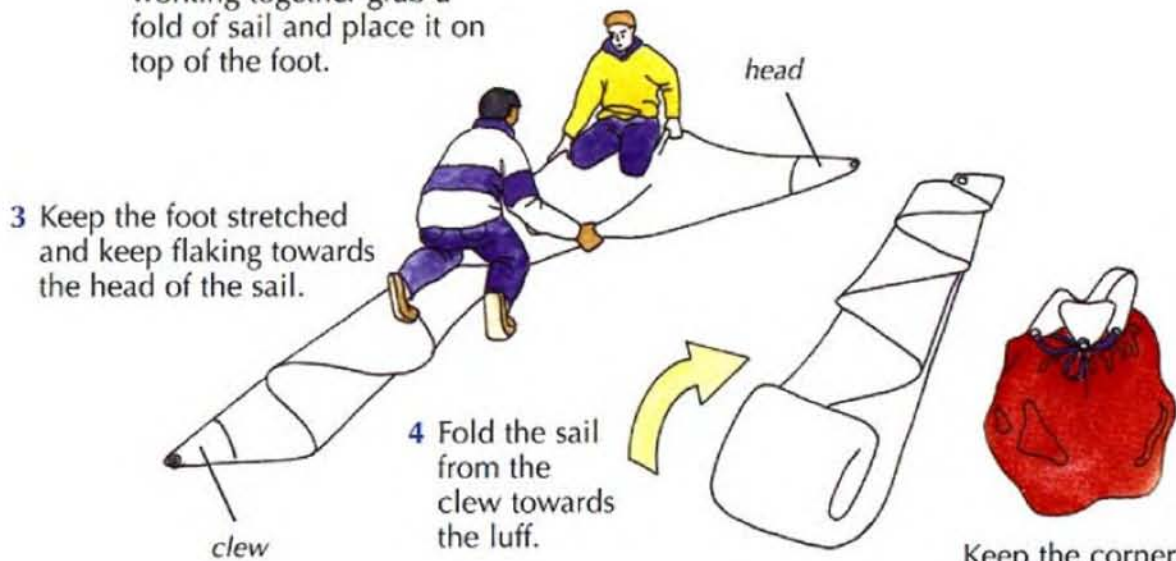

4 Fold the sail from the clew towards the luff.

Keep the corners uppermost in the bag so they are easy to find – especially the tack.

To fit into this shaped bag, make an 'S' fold to keep the head, tack and clew at the ends of the bag.

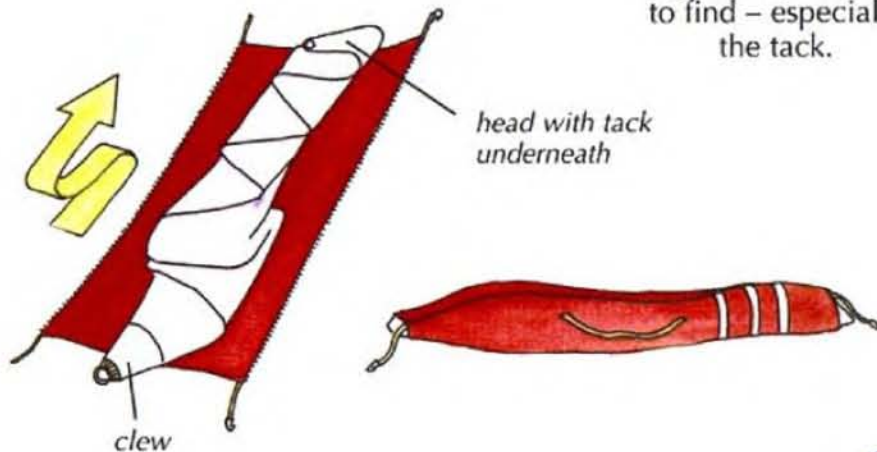



## HOW SAILS WORK

When you put a spoon into running water it is sucked into the flow.



The flow of air over the sail produces pressure changes, producing lift and increasing the speed of the wind blowing over the upper surface – like an aircraft's wing.

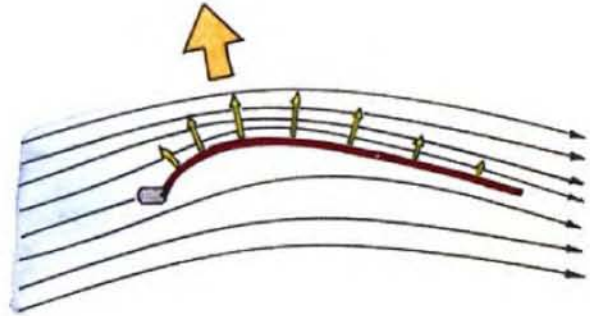

A combination of a sideways force from the sail and opposite resistance from the water pushes the boat forward like squeezing a bar of wet soap.

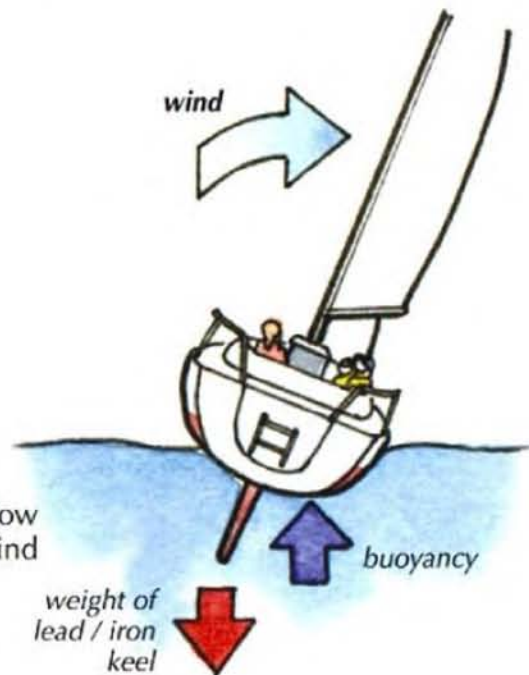

A sailing boat does not blow over as the force of the wind is counterbalanced by weight and buoyancy.

## POINTS OF SAILING

A modern yacht will sail at any angle to the wind apart from the 'no-go' zone – an angle of about 45° each side of the wind direction.

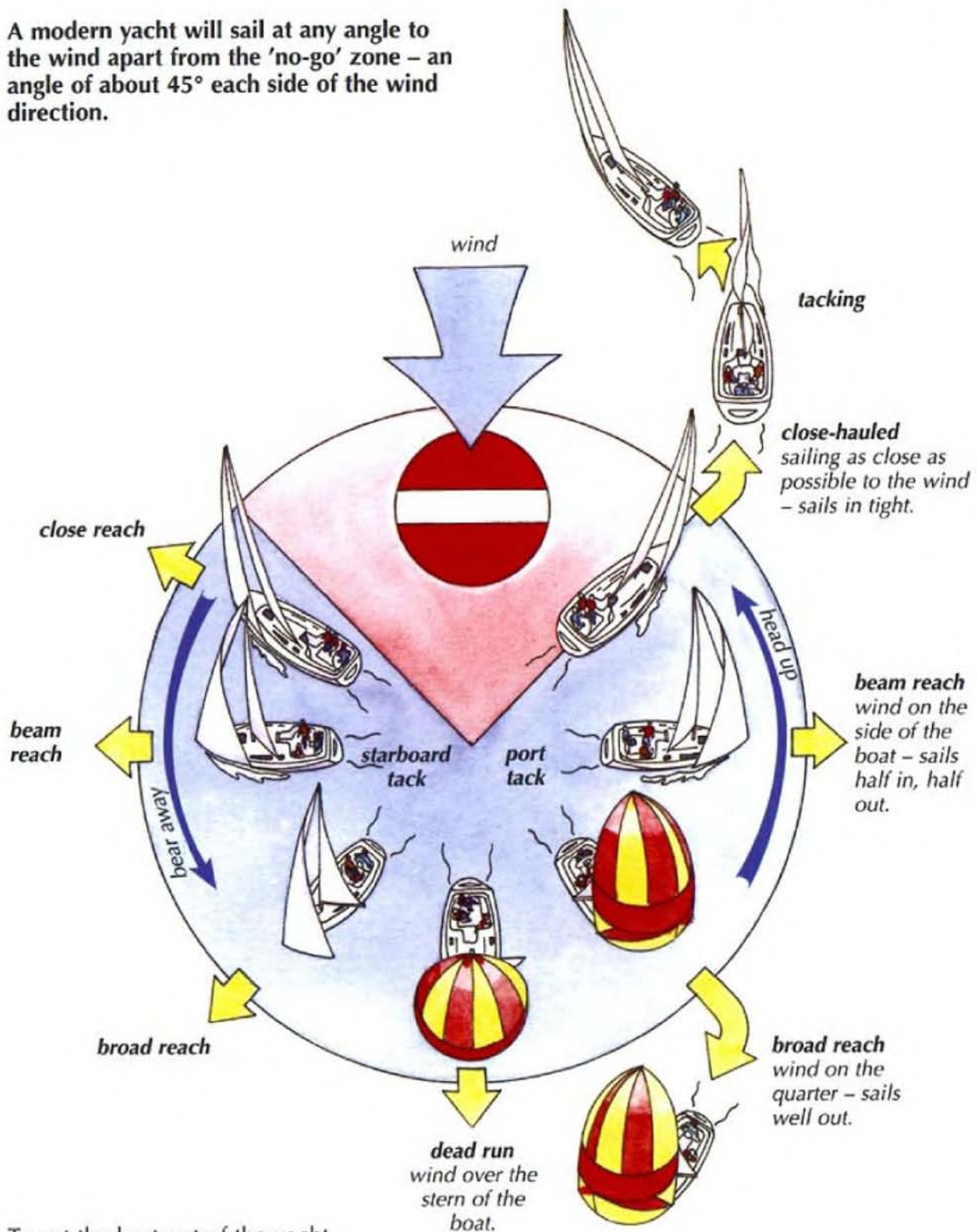

To get the best out of the yacht the sails must be correctly trimmed for each point of sailing. A change in course inevitably means the sails must be re-trimmed.

# SAILING ON THE WIND

## Close-hauled - correct course

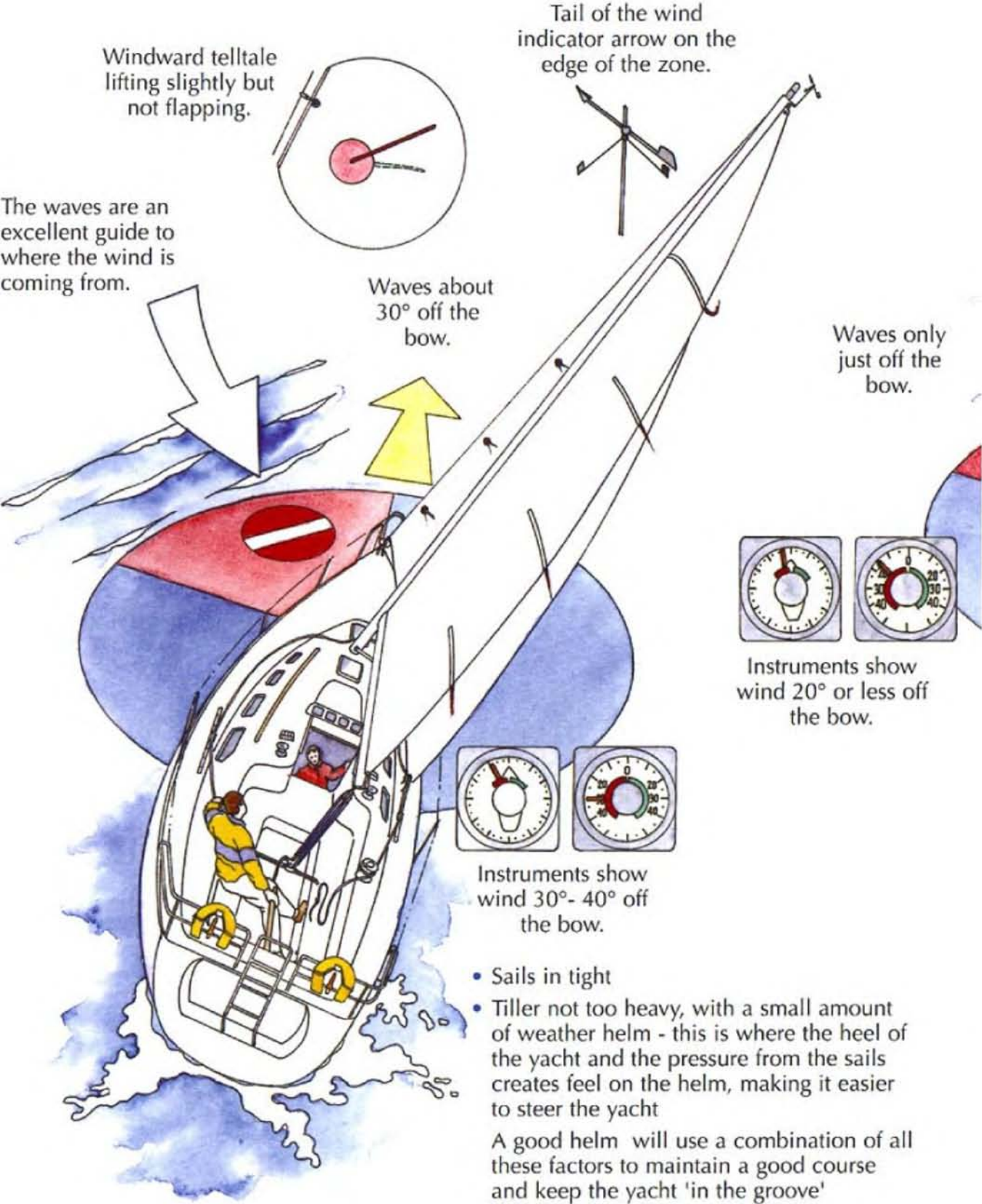

# SAILING ON THE WIND

## Too close to the wind

Windward telltale flapping.

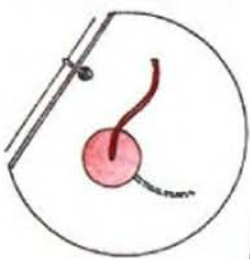

Tail of wind indicator arrows inside the zone.



To correct - bear away from the wind.

## Too far off the wind

Leeward telltale flapping.

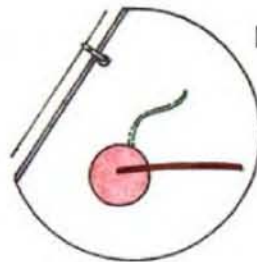

Tail of wind indicator well outside the zone.

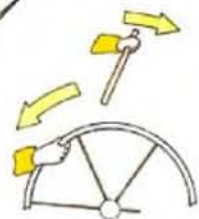
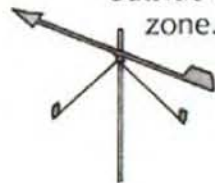

To correct - head up closer to the wind.

Waves coming from 40° or more off the bow.



Excessive weather helm.



Instruments show wind more than 40° or 50° off the bow.

## SAILING UPWIND

The bow is turning through the wind - from a starboard tack to a port tack.

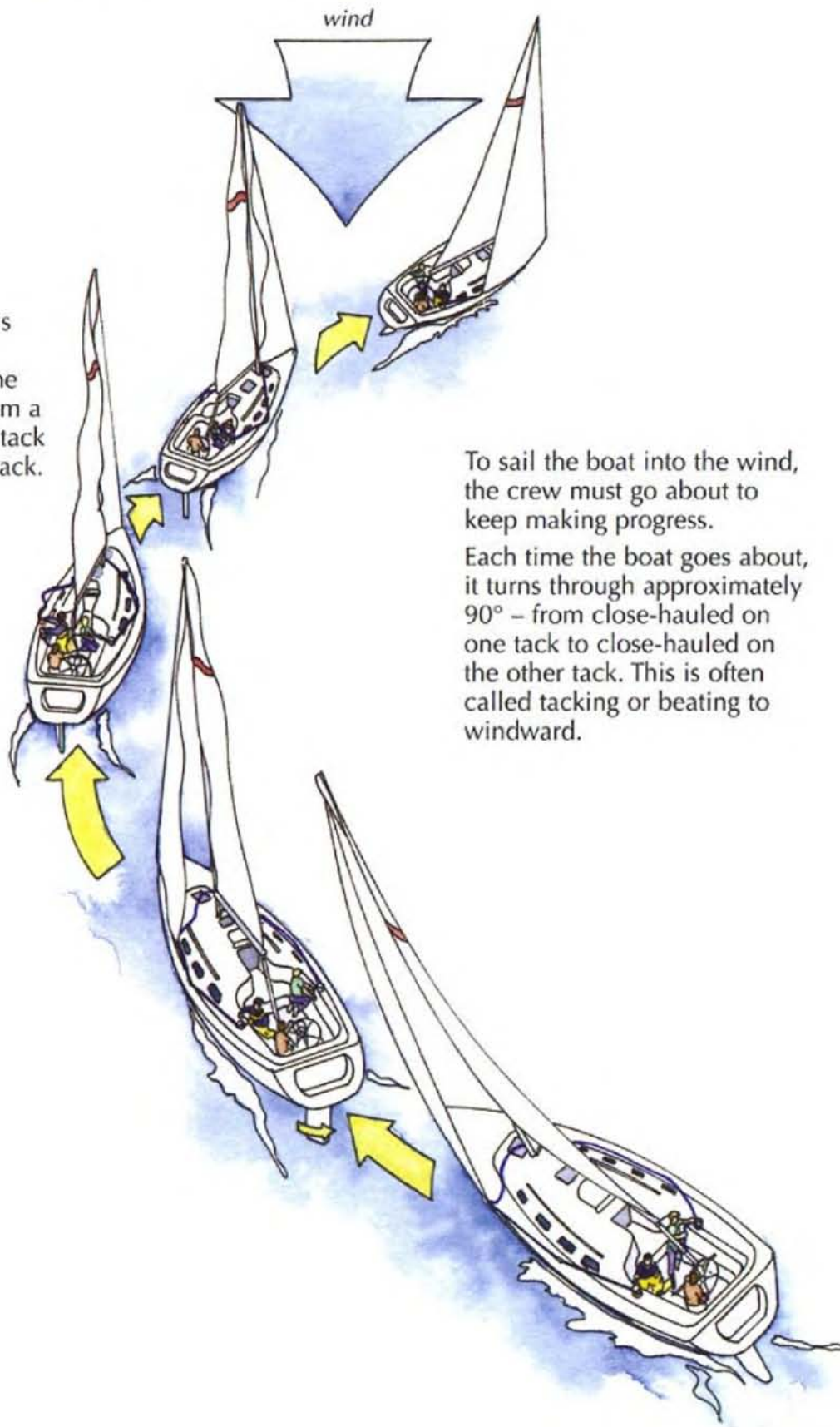

To sail the boat into the wind, the crew must go about to keep making progress.

Each time the boat goes about, it turns through approximately  $90^\circ$  - from close-hauled on one tack to close-hauled on the other tack. This is often called tacking or beating to windward.

## GOING ABOUT

Turning the boat's bow through the wind – from close-hauled on one tack to close-hauled on the other. Remember to look around before changing course.



Look around. Helmsman calls "Ready about". Crew prepares the jib sheets.

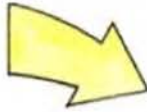

When all ready helmsman calls "helm to lee" and turns the bow towards the wind.

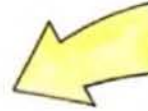

Head to wind – the crew lets fly the old jib sheet making sure it can run free, and quickly pulls in the new one, ready to winch in.



The sails have changed sides on to a port tack and begin to fill. Centre the helm.



Crew fine tunes the sail trim and tidies up.

# SAIL TRIM ON A REACH

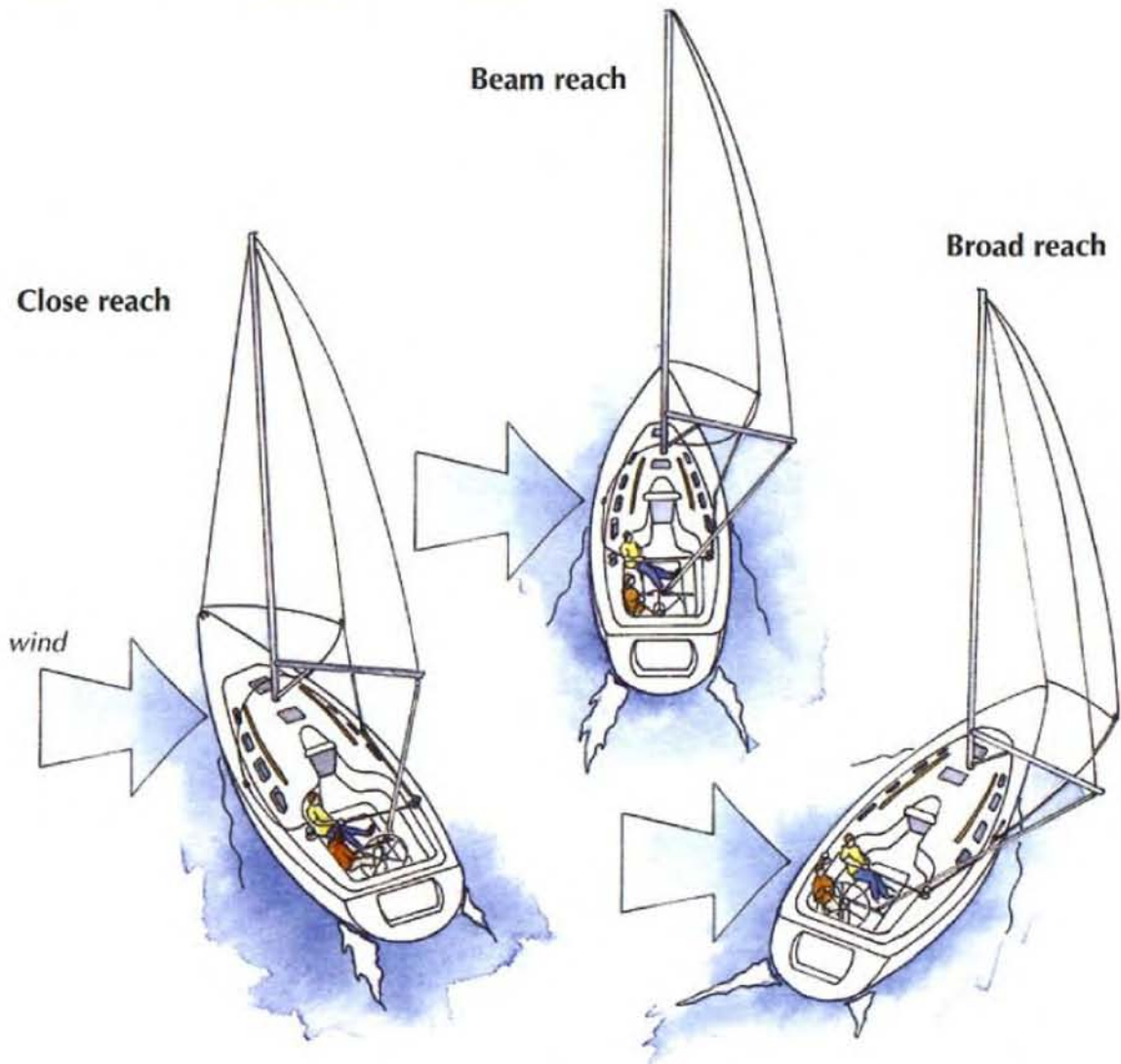

**Too loose**

Windward telltale fluttering – so winch in a little.



**Just right**

Windward telltale just lifting.



**Too tight**

Leeward telltale fluttering – ease out the sheet a little.

# SAILING DOWNWIND

Sailing with the wind abaft or behind the beam of the boat.

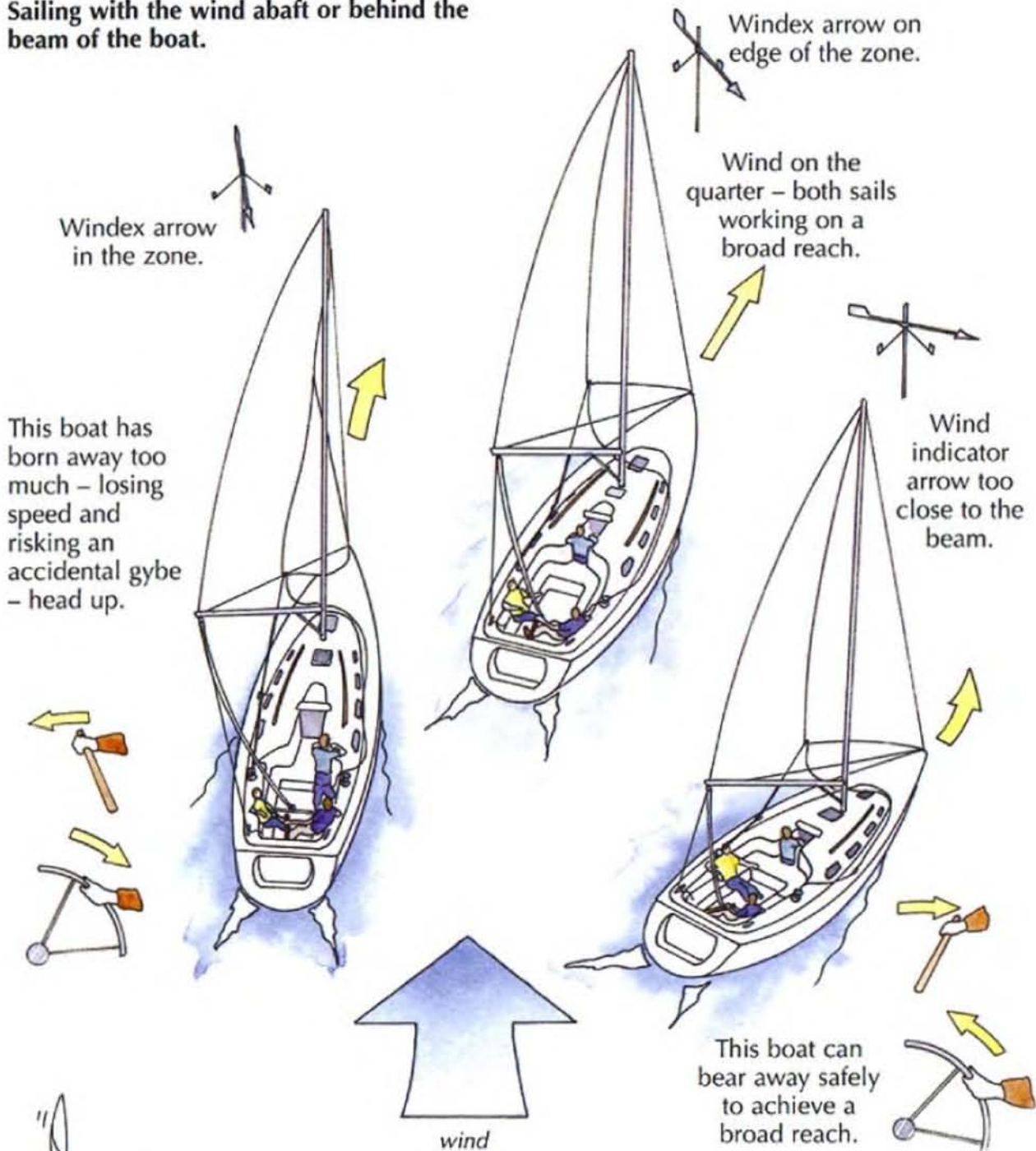

### An accidental gybe

If the boom moves suddenly and unexpectedly across the boat it can be dangerous. With the wind from behind the boat, if the helmsman bears away too much the jib will collapse because it is in the wind shadow of the mainsail. This indicates that you are close to a gybe. Head up a little closer to the wind to avoid an accidental gybe and get the jib working again.



## SAILING DOWNWIND

### Poled-out headsail

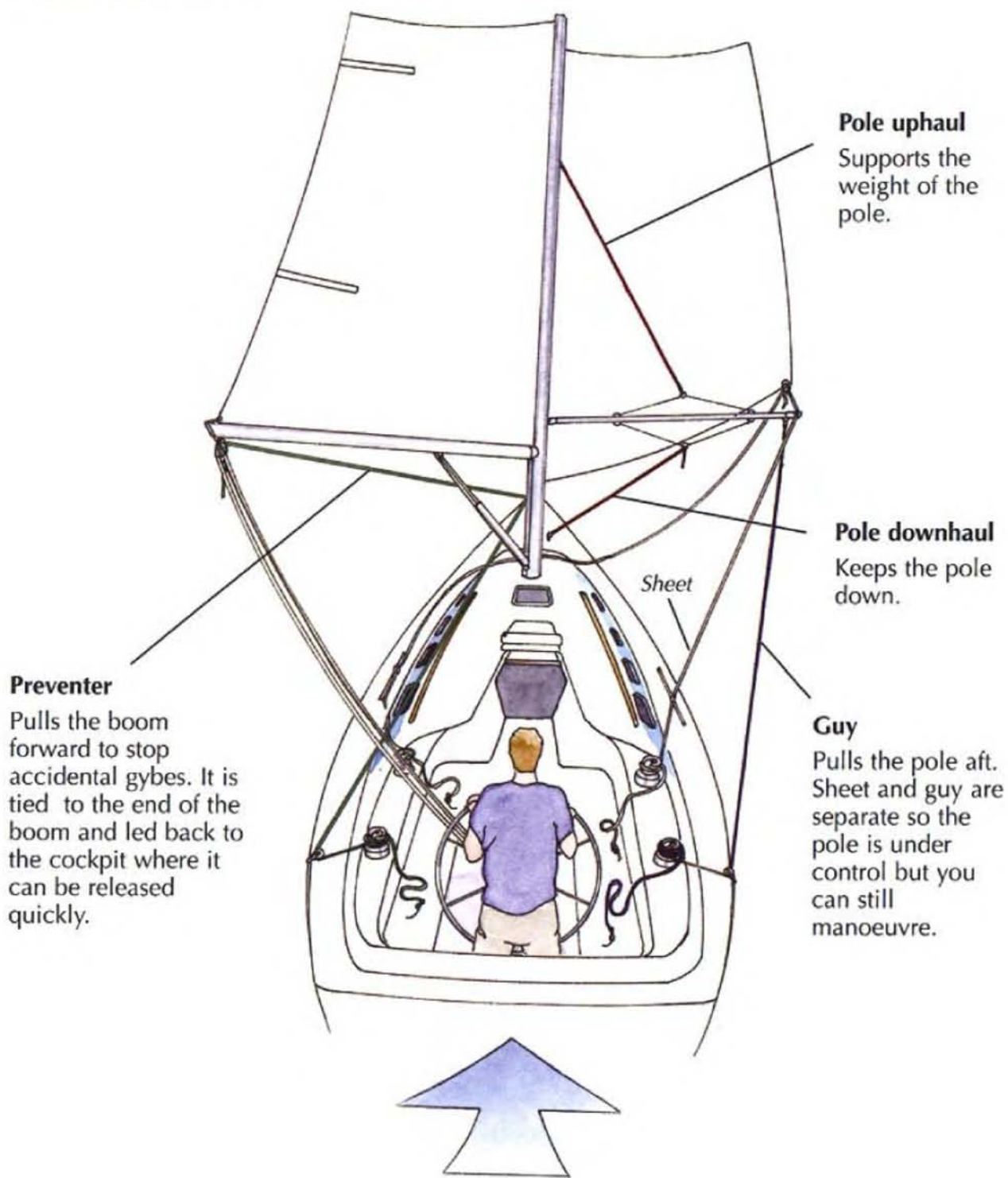

**Pole uphaul**  
Supports the weight of the pole.

**Pole downhaul**  
Keeps the pole down.

**Preventer**  
Pulls the boom forward to stop accidental gybes. It is tied to the end of the boom and led back to the cockpit where it can be released quickly.

**Guy**  
Pulls the pole aft. Sheet and guy are separate so the pole is under control but you can still manoeuvre.

Wind Dead Astern

(The mainsail is on the port side so the boat is on STARBOARD tack)

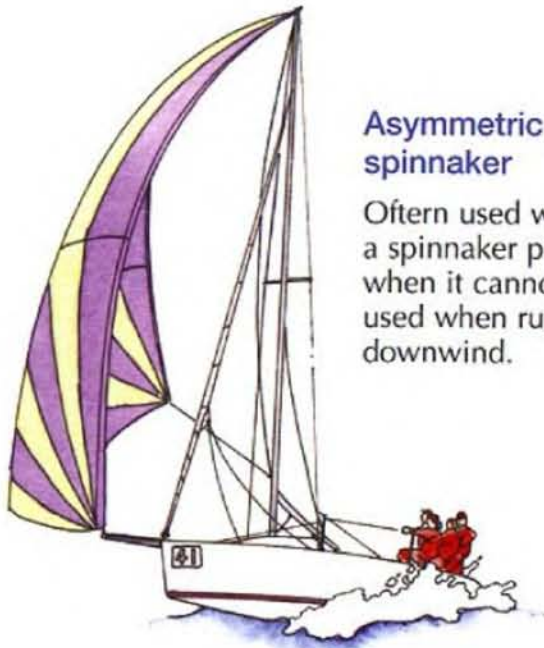

**Asymmetric spinnaker**

Often used without a spinnaker pole, when it cannot be used when running downwind.

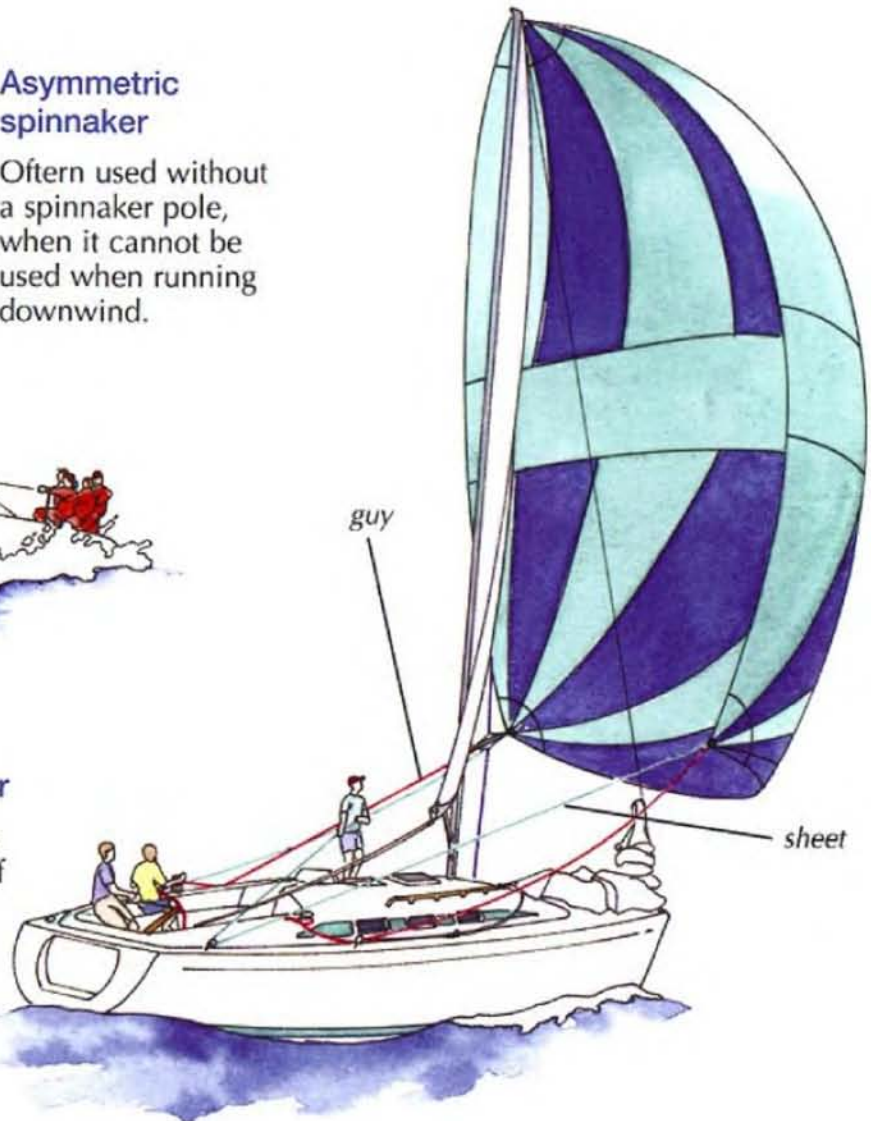

**Symmetric spinnaker**

A versatile sail that can be used on all points of downwind sailing. It needs several crew to set and trim.



**Cruising chute**

Made from similar material to a spinnaker but rigged like a genoa. It is set without a pole, uphaul, downhaul or guy; this makes it easy to handle. It does not set very well when running downwind.

## GYBING UNDER CONTROL

When sailing downwind it is often faster overall and safer to zig zag downwind, sailing a series of broad reaches using a controlled gybe.

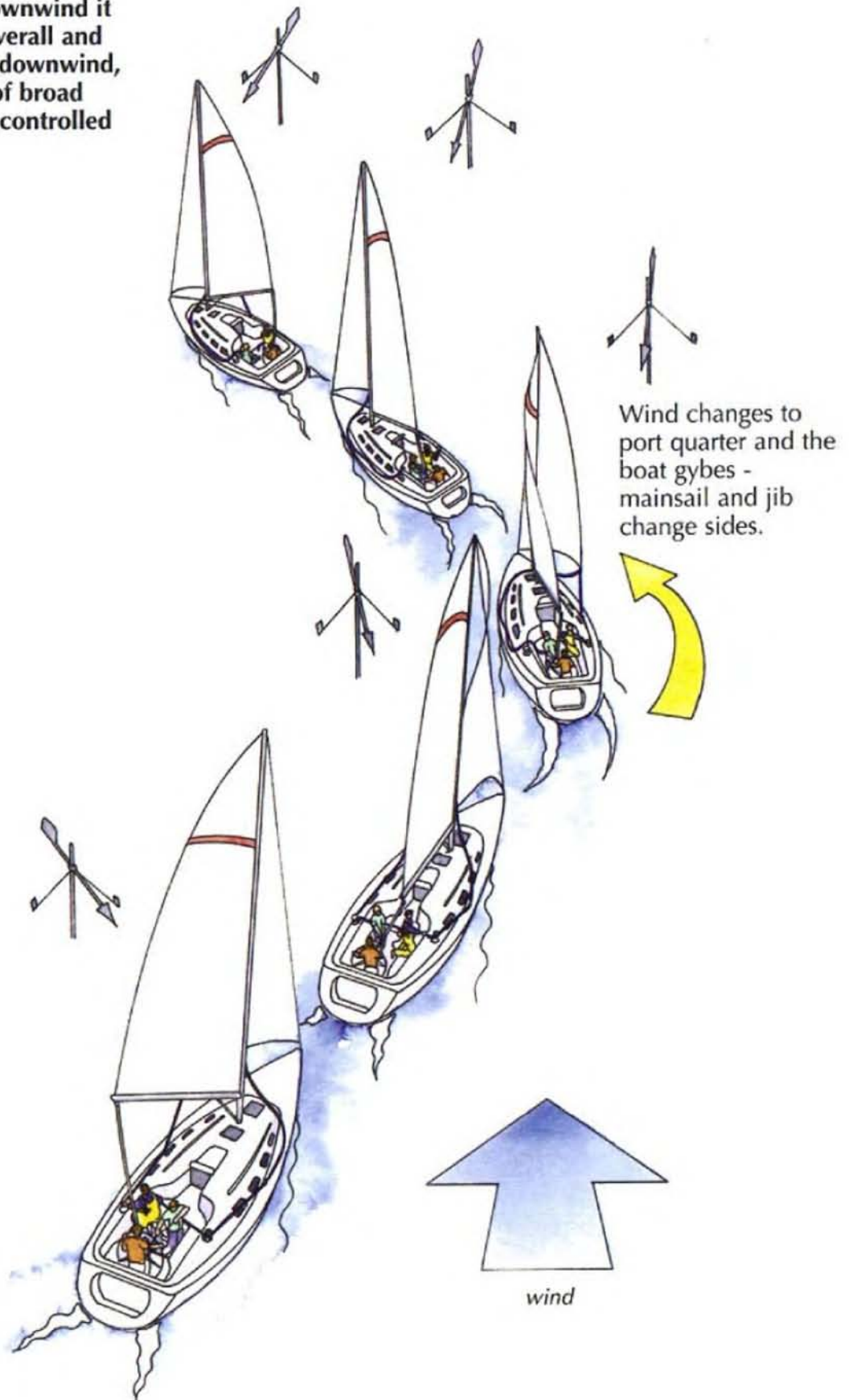

## GYBING UNDER CONTROL

A controlled gybe from a broad reach or a run is a safe procedure.

The helmsman starts the sequence by calling 'stand by to gybe'. If a gybe preventer is rigged it is released. The crew sheets the mainsail in and prepares the headsail sheets.



When the main is in the middle the helmsman turns the wheel to gybe.

The main flips across, sheet the jib in on the same side as the main and when it is under tension release the other sheet.



The mainsheet is eased out.

The crew make final adjustments to sail trim. The gybe preventer may be rigged again.



## STEERING

When a yacht is turned it will pivot about the keel. The rudder is moved by pushing or pulling on the tiller or turning the wheel.

### Tiller steering

Push the tiller to port to turn the boat to starboard and vice versa.

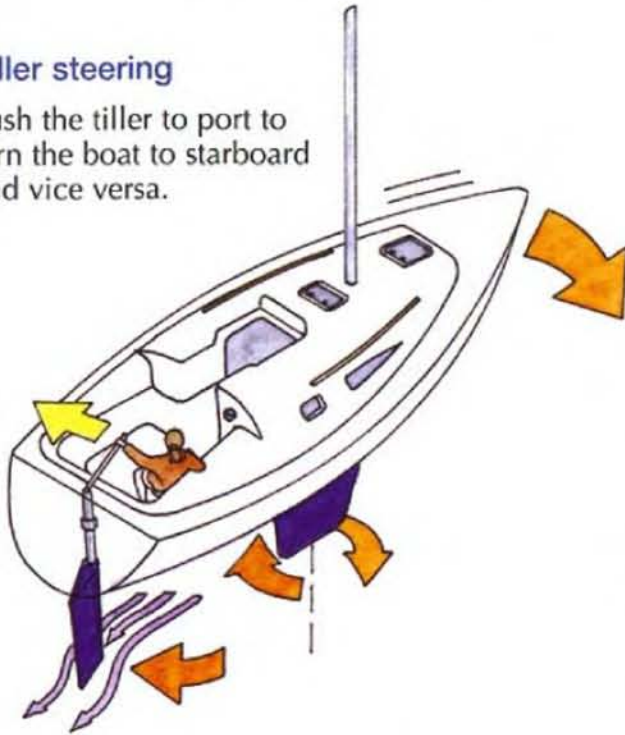

### Wheel steering

Turn the wheel the same way you want to turn the boat.



If you are off course, correcting takes practise. Make a small alteration, straighten up and check the effect on the compass. Average the course - if you have consistently sailed on one side of the course, compensate by sailing an equal amount on the other.

Too far to port

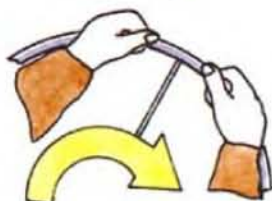

Correct course

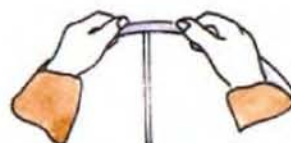

Too far to starboard

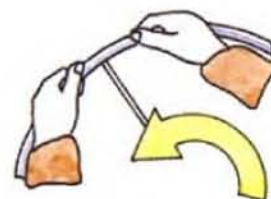

## STEERING A STEADY COURSE

To steer a straight and steady course at sea, check the compass from time to time and watch the bow of the boat relative to the horizon.

Use as many references as you can to orientate yourself; for example, the position of the sun, angle of the waves and the wind.

One of the best references is an object in front of you; you can even use a cloud for a short while. An occasional check on the compass should keep you on a steady course.

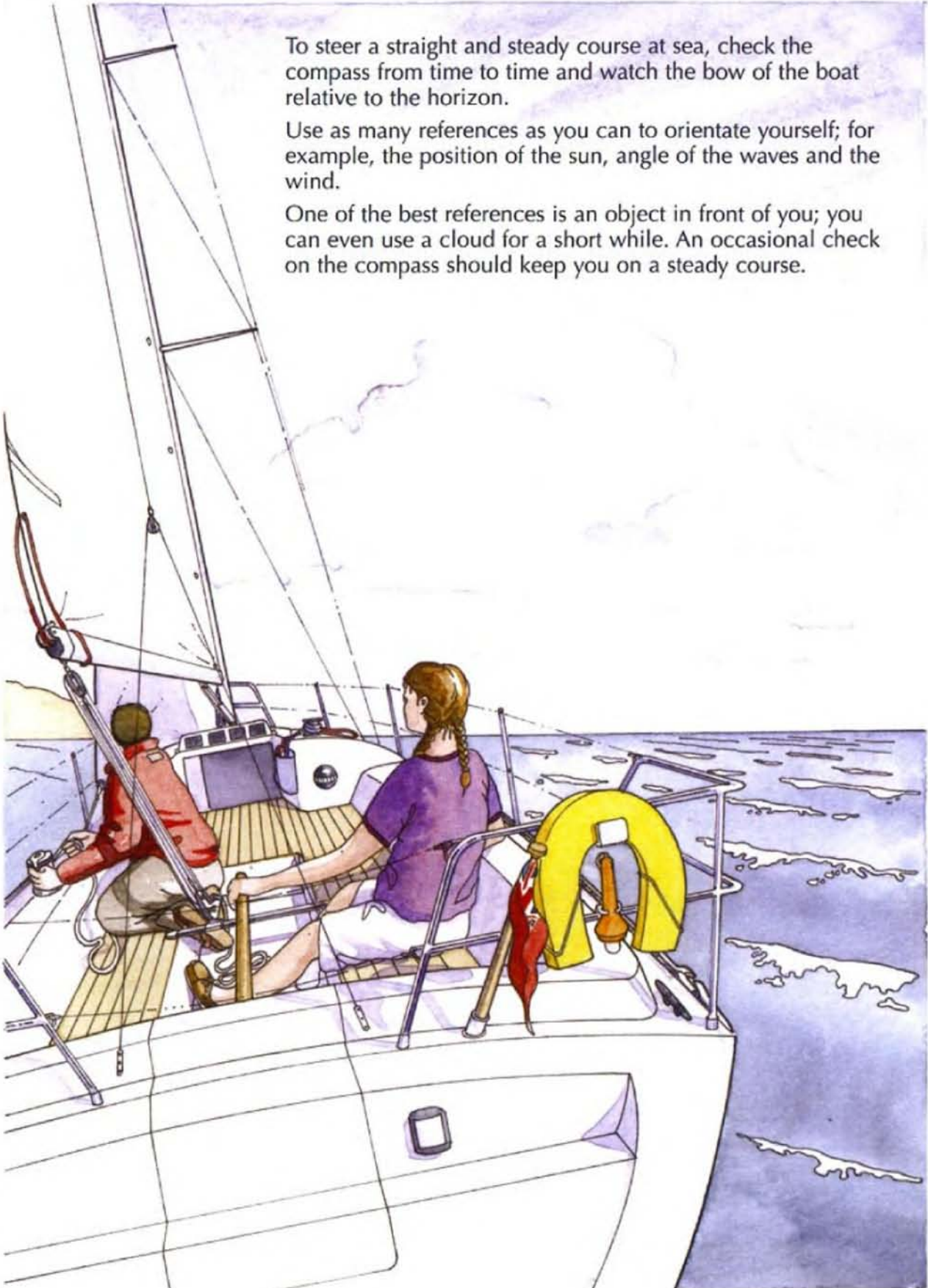

## COMING ALONGSIDE IN A MARINA

- 1 The skipper will call the marina on VHF Channel 80 to arrange a berth.

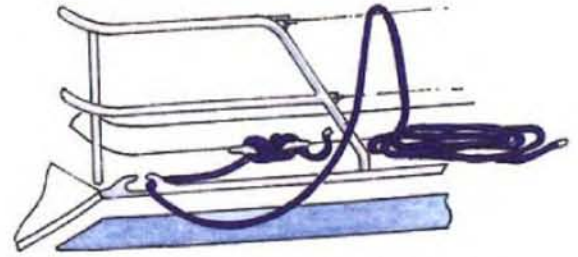

Lead the warp from the cleat, through the fairlead forward to the side deck ready for the crew to take ashore.

A crew member stationed near the bow can protect the boat if necessary with a fender and call distance off to the helmsman.

- 2 Prepare the fenders and mooring lines on both sides of the boat to be ready for any change of plan.

- 3 Position the crew amidships ready to step ashore.

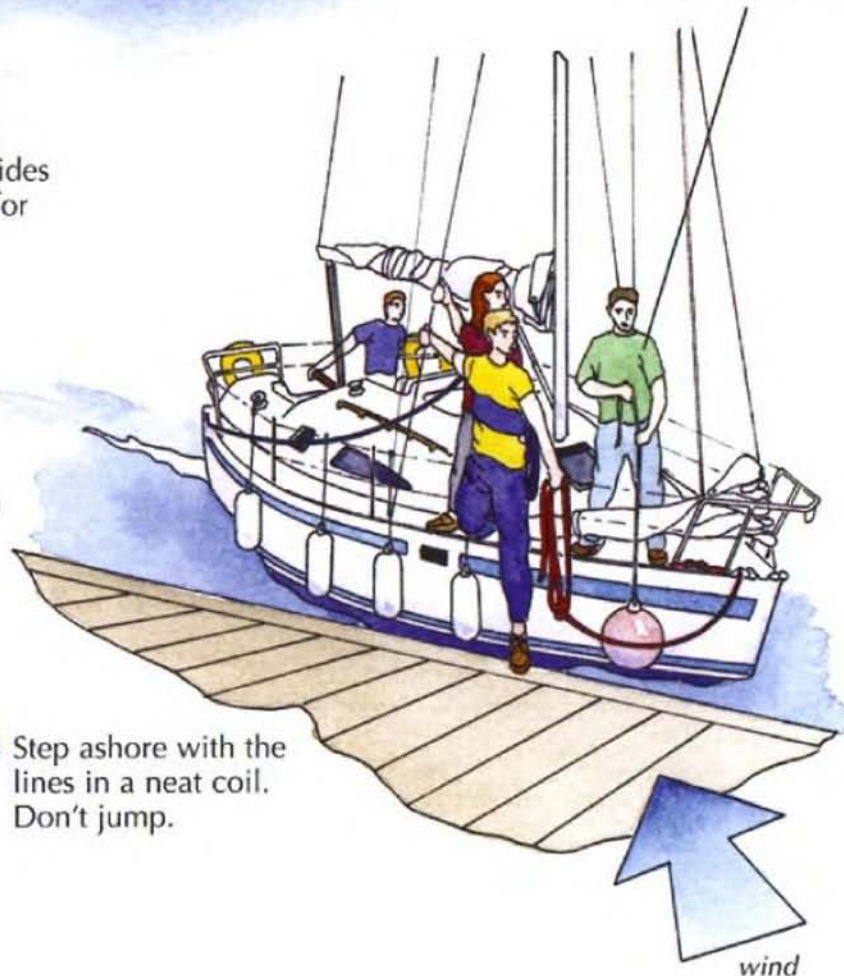

- 4 Step ashore with the lines in a neat coil. Don't jump.

## COMING ALONGSIDE IN A MARINA



5 Take a turn round a cleat and be ready to pull in or ease out as necessary.

The bow line is led forward.

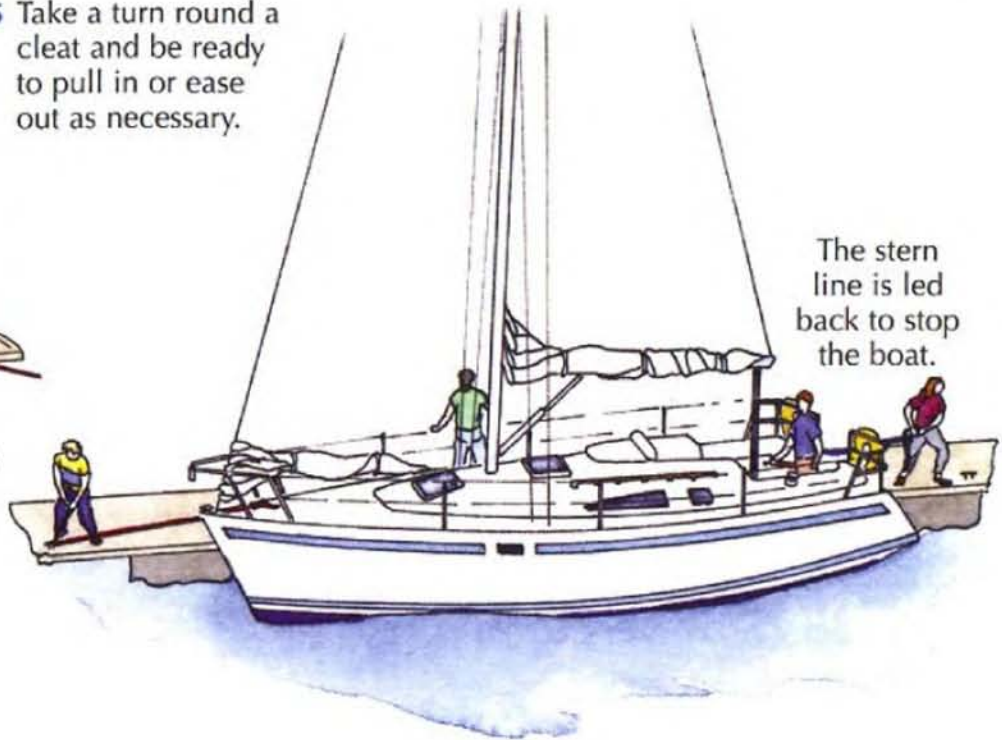

The stern line is led back to stop the boat.

Set up a bow and stern spring to prevent surging.

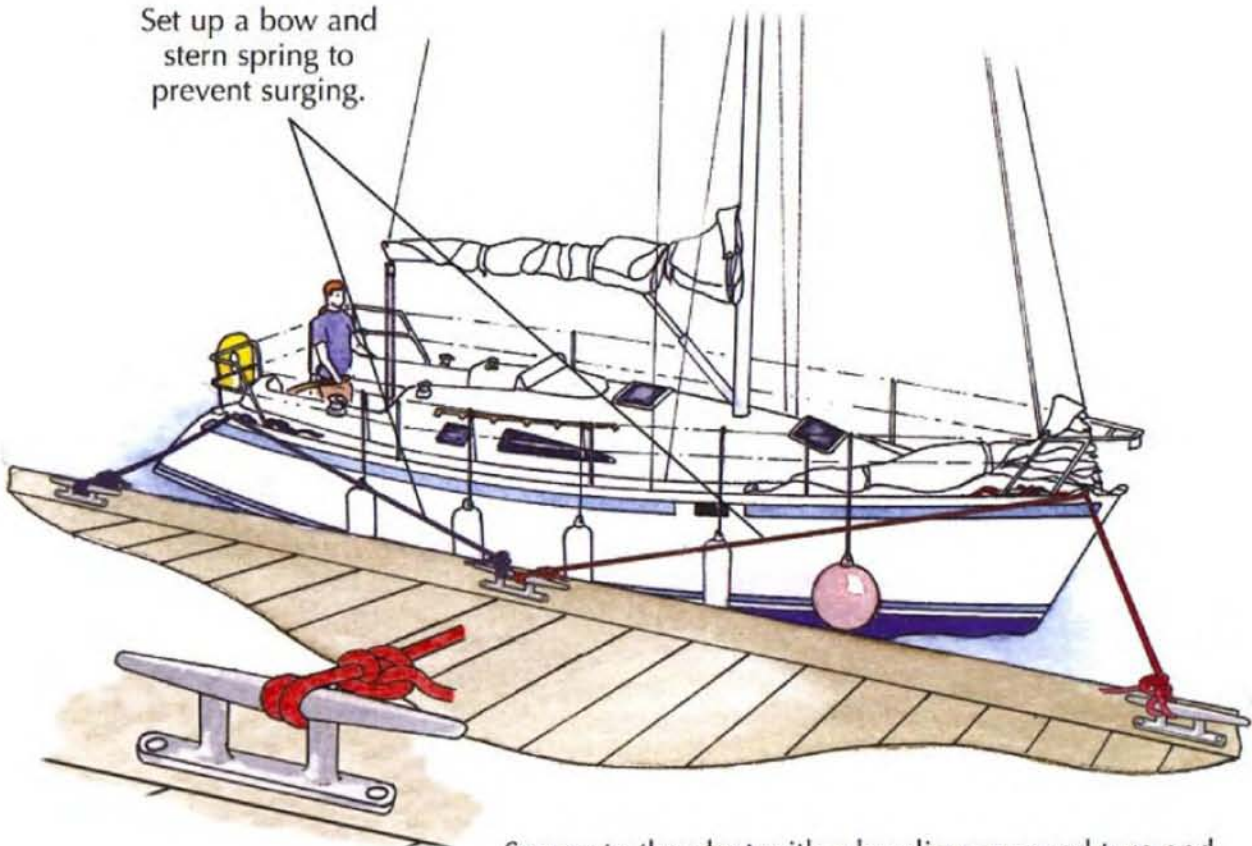

Secure to the cleat with a bowline or round turn and two half hitches; take up the slack on board.



## MOORING ALONGSIDE ANOTHER BOAT

- 1 If possible, first ask the other boat if they are about to leave.
- 2 Moor to the other vessel using fenders rigged higher than normal, bow line, stern line and springs. Then lead long lines ashore so that all the weight of your boat is not hanging on the other boat's lines. Check the boats are parallel – so you don't end up bows in.
- 3 Make sure the lines are long enough to allow for any rise and fall of tide.

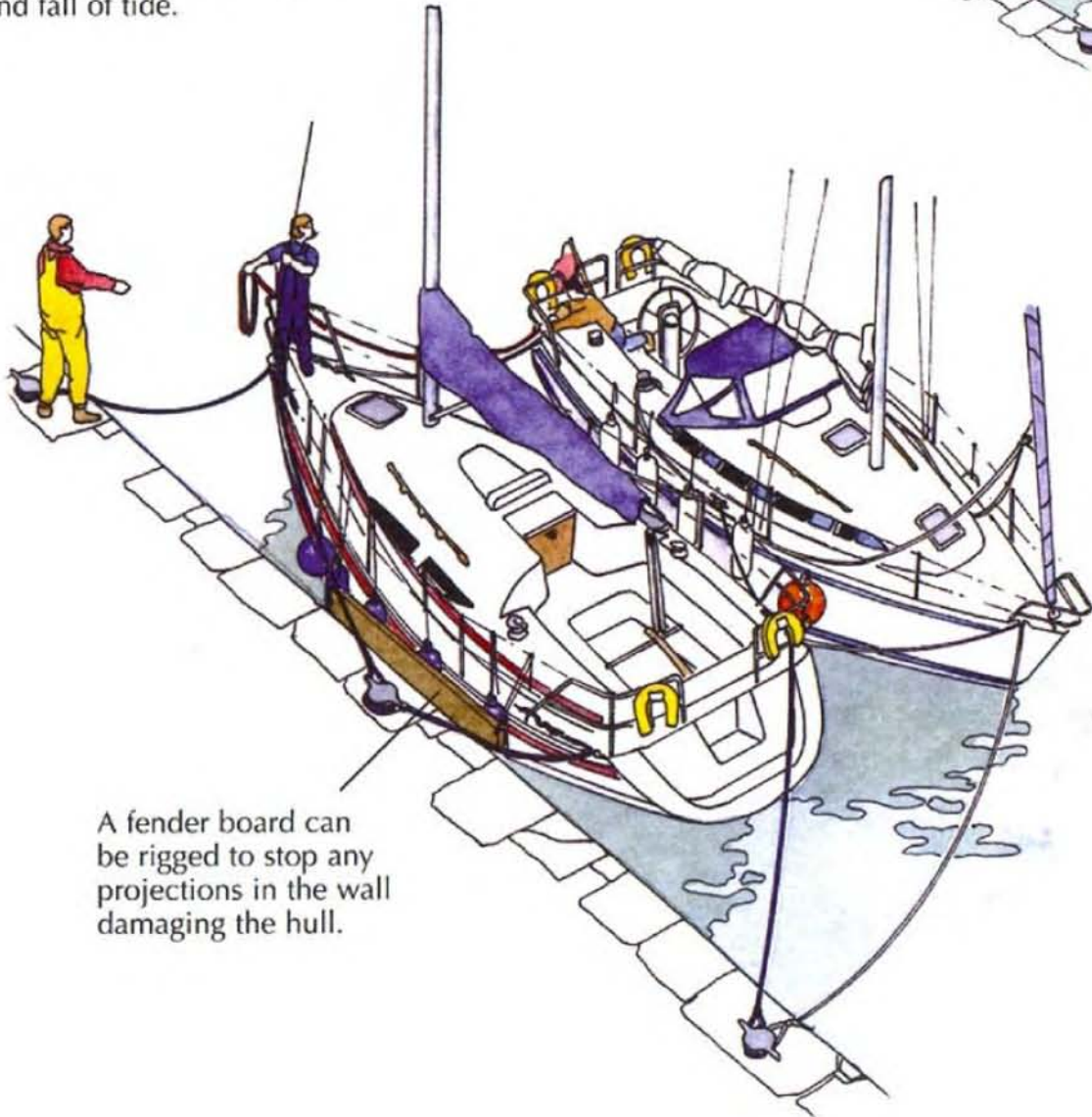
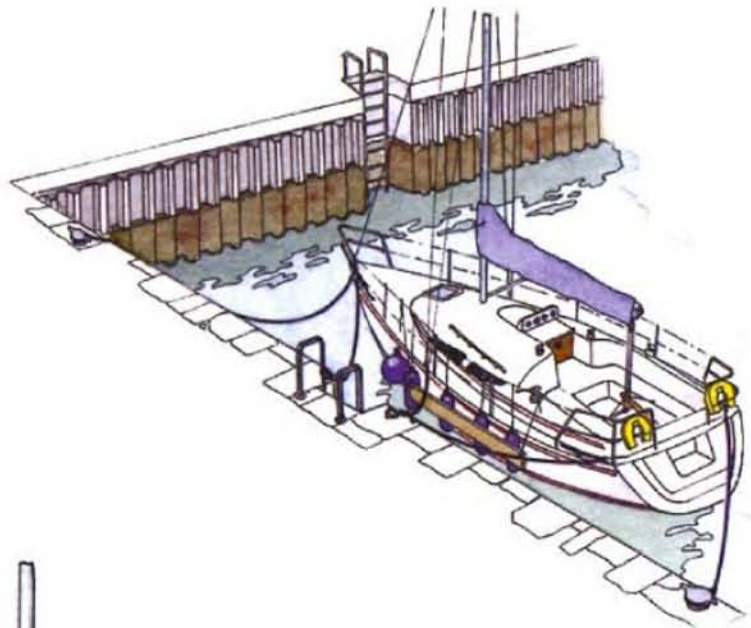

A fender board can be rigged to stop any projections in the wall damaging the hull.

## LEAVING A BERTH

### Alongside berth

Get the lines ready to slip; remember the short end of the line should be on top of the cleat.

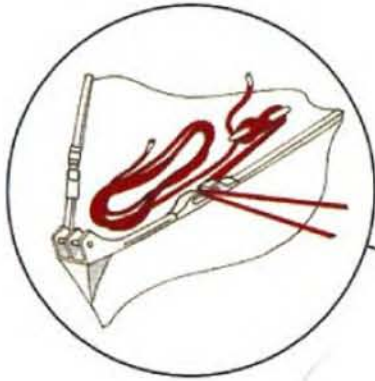

The boat is being motored ahead so it pivots to bring the stern out – the fender is essential.

Motoring ahead on a bow spring forces the bow in and the stern out.

A slip line can be released and quickly pulled on board.

This slip line must be carefully prepared to slip when the skipper reverses away.

### Leaving a raft

Crew ready to pull in bow line from the boat to the shore.

The new stern line from the motor cruiser is being led ashore – round the stern of the departing boat.



Once the yacht has left, secure the motor cruiser to the yacht with bow and stern lines and springs. Retain the shorelines too.

Yacht preparing to leave, shore lines removed.

Boat securely moored – bow line, stern line and springs.

## PICKING UP A MOORING

- 1 The skipper will approach the mooring in the same direction as the other moored yachts are lying – usually into the tidal stream or head to wind if no tide.
- 2 Point towards the buoy and call the distances – the helmsman probably can't see the buoy.

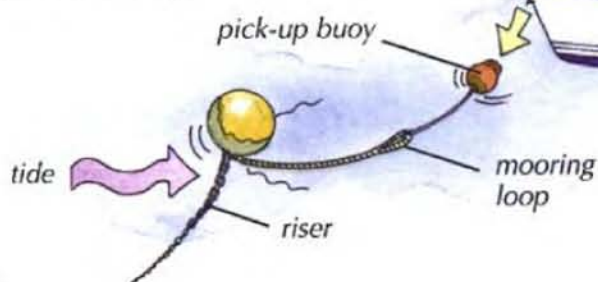

- 3 Lift the pick-up buoy to catch the mooring loop.

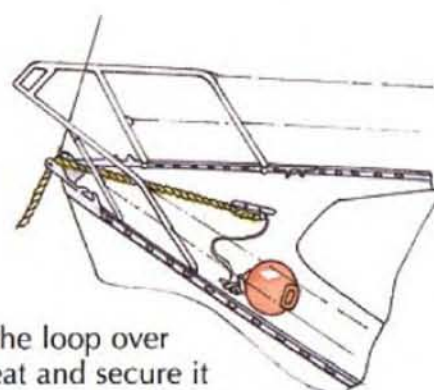

- 4 Drop the loop over the cleat and secure it in position. Make sure it is led through the bow roller.

### Where there is no pick-up buoy or rope

Be ready to lean down to the buoy.

- 1 One crew catches the buoy by the ring whilst the other attaches a mooring warp.



The buoy may be very heavy.

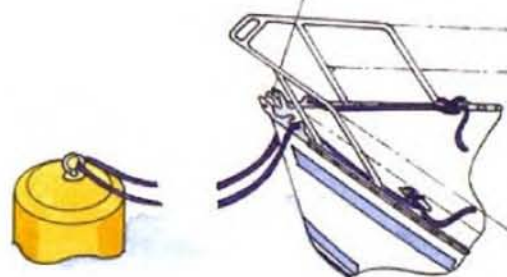

- 2 For a brief stay rig a slip line through the ring on the buoy using a mooring warp.



- 3 For an overnight stop secure with a round turn and a bowline.

## ANCHORING

### Dropping anchor

If necessary secure a tripping line to the anchor and lead it so it cannot get caught up when the anchor is put down.

Secure to the cleat; make sure that the end of the chain that goes back into the locker is on top of the cleat.

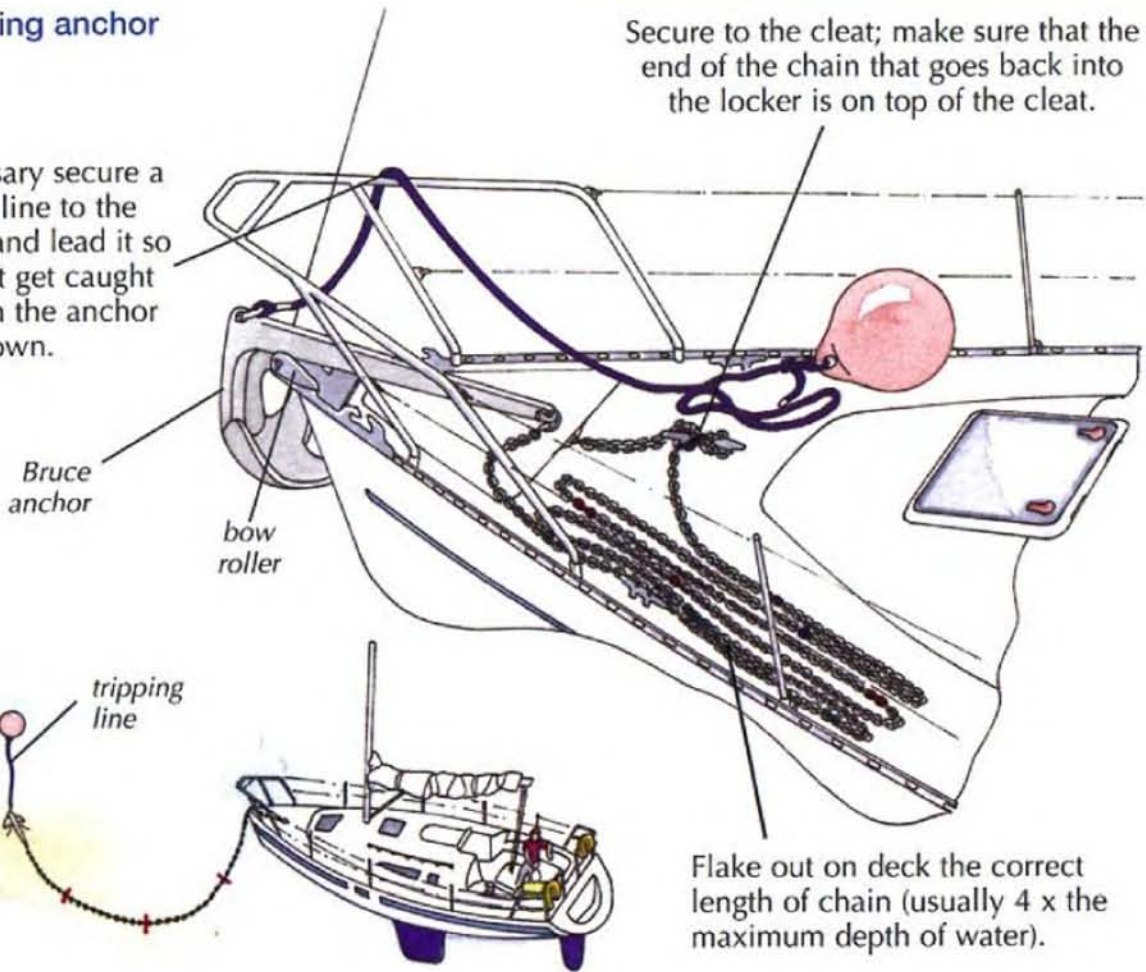

Flake out on deck the correct length of chain (usually 4 x the maximum depth of water).

### Weighing anchor

If the anchor is fouled, use the trip line to pull it free.

Pull up the chain to raise the anchor – bend your knees, not your back.

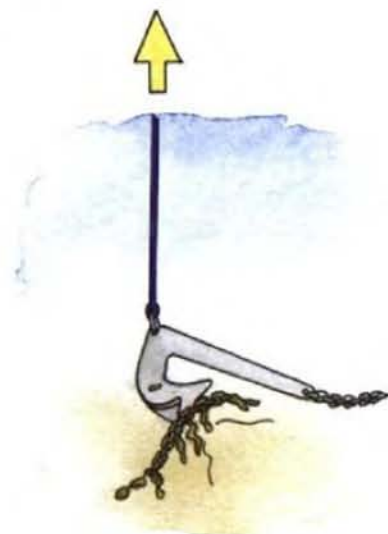

The skipper will motor the boat gently forward to take the weight off the chain.

# RULES OF THE ROAD

## SAILING VESSELS

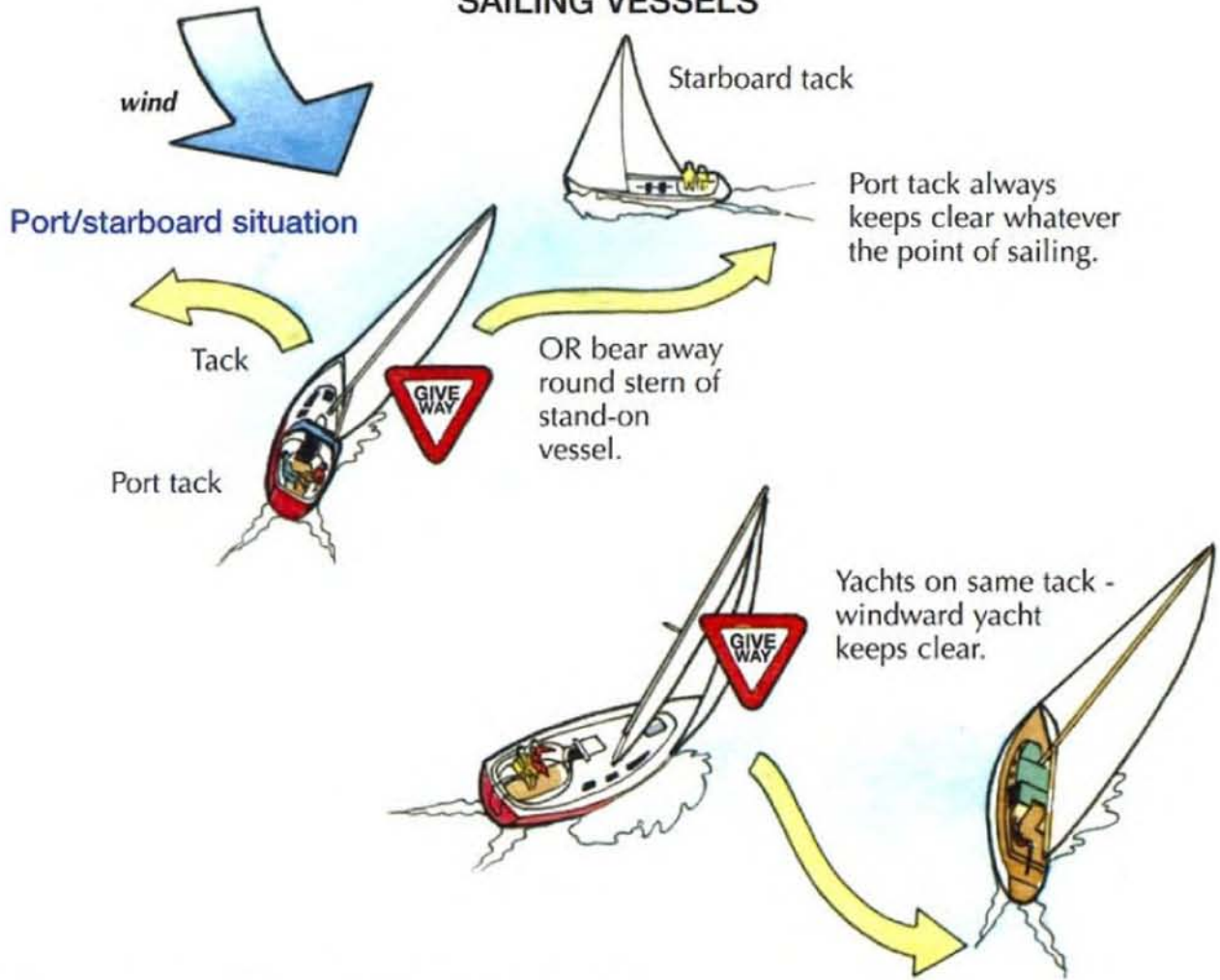

How can we tell if a risk of collision exists?

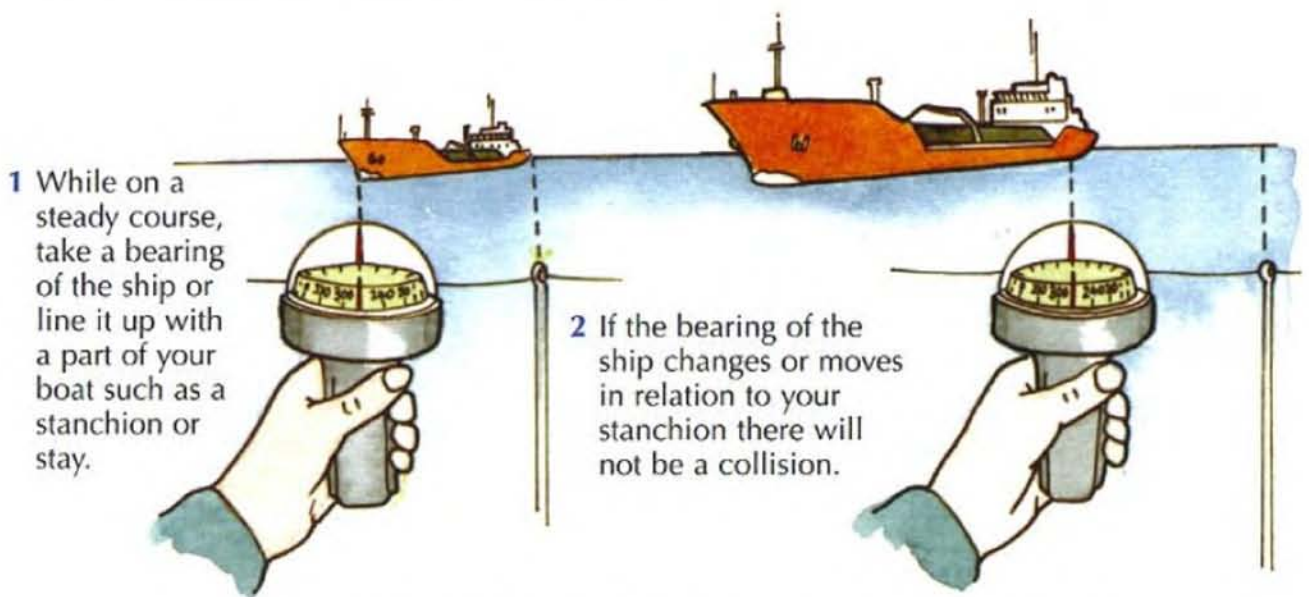

**If the bearing stays steady or the ship remains lined up with your stanchion - a risk of collision exists.**

# WHO GIVES WAY?

## Head-on situation

Both vessels turn to starboard.

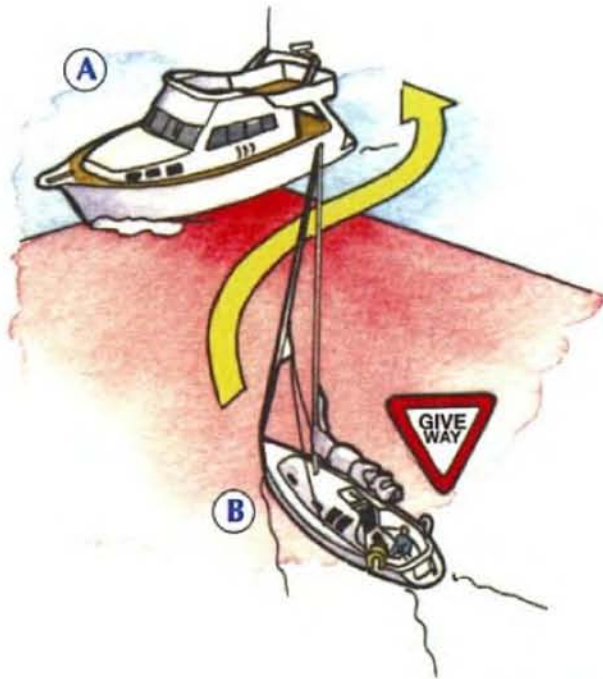
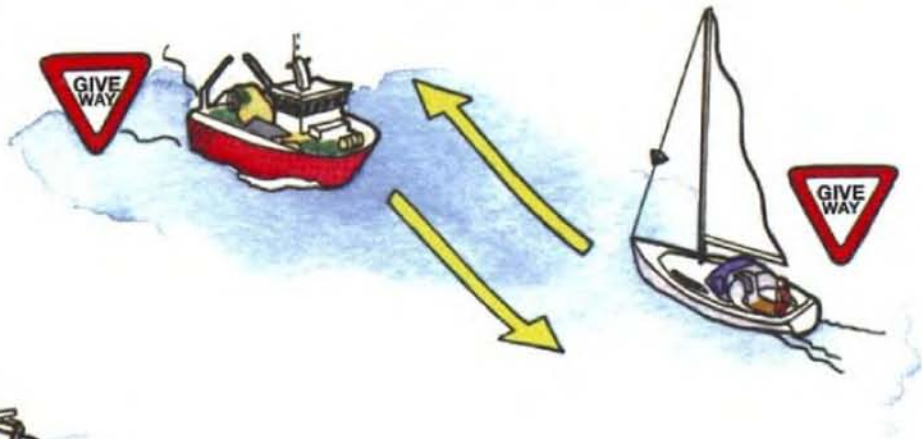

## Crossing situation

A is on the starboard side of B.  
B gives way to A.

## Overtaking situation

Stand-on vessels must keep a steady course and speed.

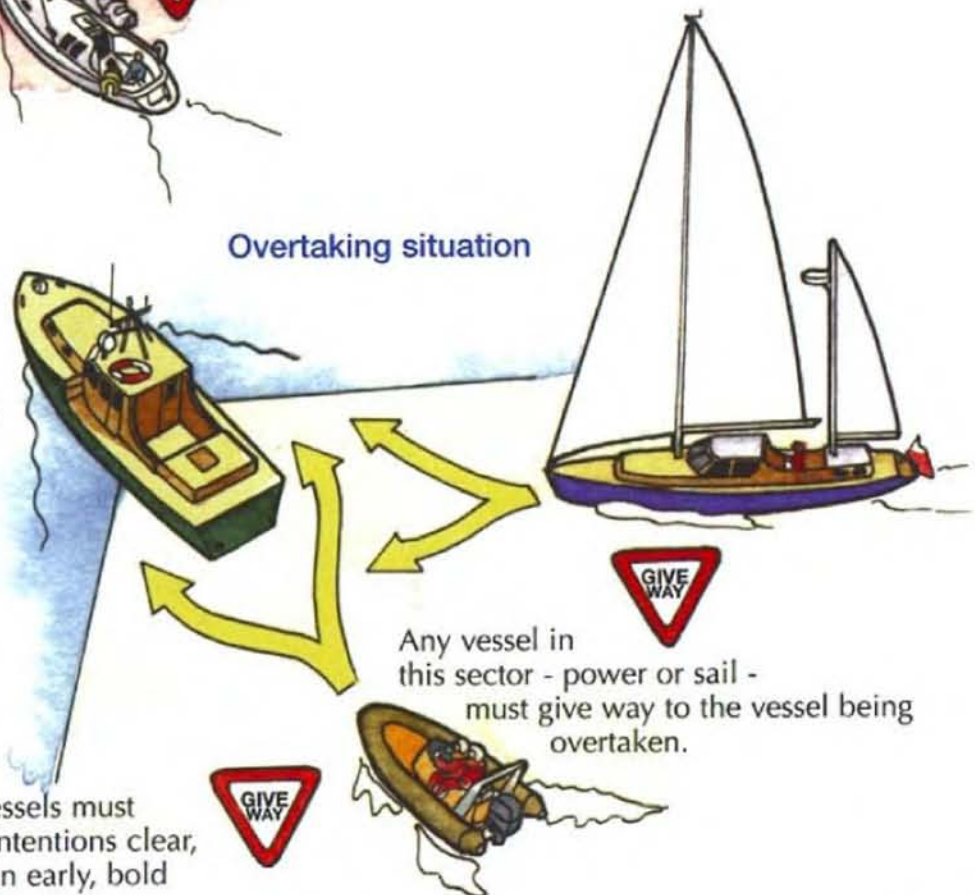

Any vessel in this sector - power or sail - must give way to the vessel being overtaken.

Give-way vessels must make their intentions clear, by making an early, bold alteration of course.

## KEEPING A LOOK-OUT

### DAY look out for:

- Racing marks and fishing pots.
- Fast approaching sea-cat and ship.
- Rubbish in the water.
- Yacht on closing course
  - who is the give-way vessel?
- Where is the shipping lane?
  - are we out of the way of the ships?
  - where are the buoys?
  - what is the depth on the echo sounder? Too shallow and we might go aground. Too deep and we could be in the main shipping channel.
- Listen to the VHF for information.



## KEEPING A LOOK-OUT

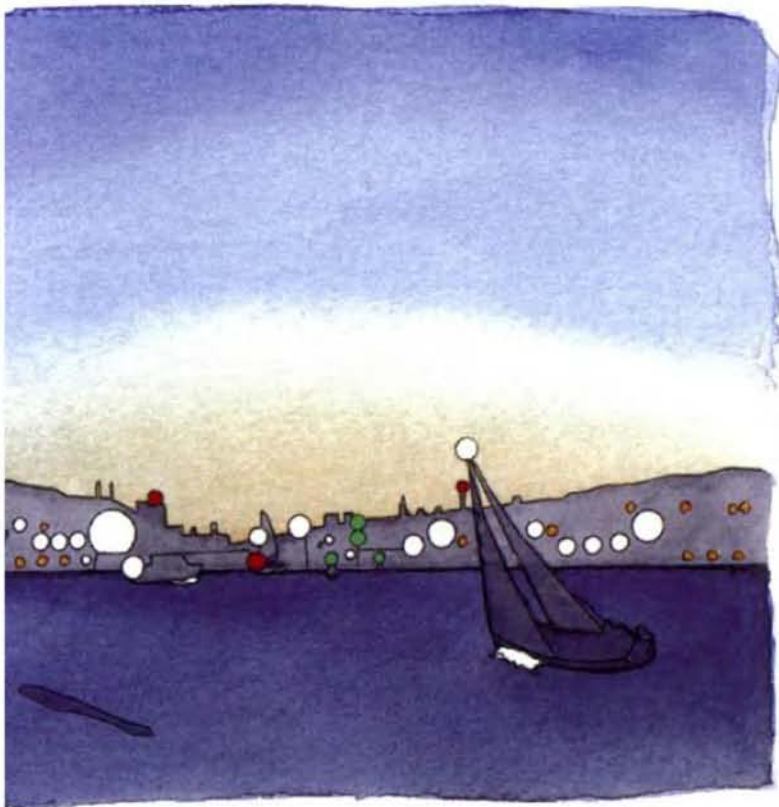
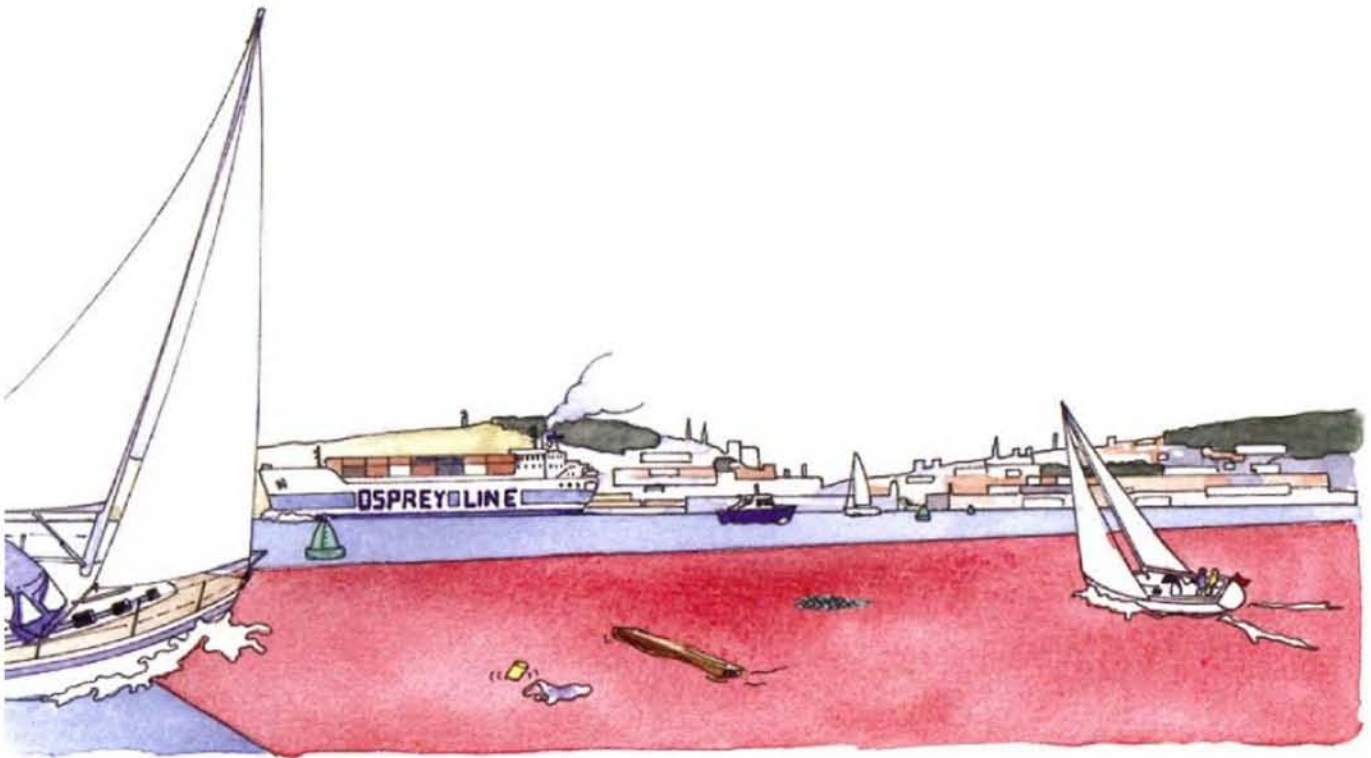

### NIGHT look out for:

- Lights
  - flashing lights are navigation marks – buoys, beacons, lighthouses.
  - fixed lights at sea are boats.
  - near harbours it can be difficult to spot vessels or buoys because of the background lights.
- All crew should clip on.
- Watch for unlit buoys and flotsam.
- Do not use lights down below – it ruins everyone's night vision.
- Watch for small boats moving – not just ships.



## WATCH KEEPING

**You will probably keep watches if you are sailing for longer than a normal day.**

A good skipper doesn't wait until nightfall to start the rota when everyone is already tired. They will share out duties, make sure the crew keep warm and dry and have suitable meals.

A good watch keeping rota will prevent the crew being alone, tired and cold at night.

SKIPPER - SAM	
WATCH LEADER - DAVE	
WATCH	NAME
0000 - 0300	DAVE
0300 - 0600	CATHY
0600 - 0900	DAVE
0900 - 1200	CATHY
1200 - 1500	DAVE
1500 - 1800	CATHY
1800 - 2100	DAVE
2100 - 0000	CATHY

When you are on watch make sure you look all around you and behind the jib periodically.

When you are coming on watch arrive in good time.



## SAILING MANNERS AND NAUTICAL CUSTOMS

In harbour, raise the Ensign at 0800 (summer) and 0900 (winter). Lower the Ensign at sunset or 2100 BST, whichever is earlier. The Ensign is flown day and night at sea.

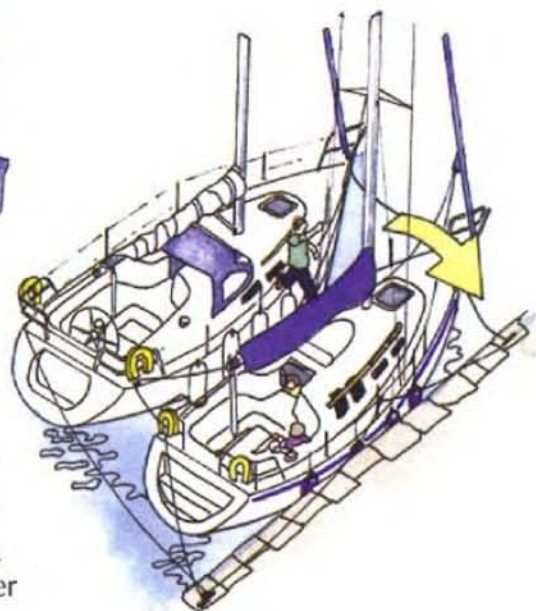

Before mooring alongside ask – then walk round by the foredeck to go ashore – quietly. Don't wake up other crew when you return.



Do not throw food stuff over the side – even if it is biodegradable.



Do not dump rubbish in the sea.



Do not use the heads in the marina unless you have a holding tank.



Do not pump or spill oil, diesel, paint or other chemicals into the water.

# USING THE DINGHY

Every year more accidents happen to crews going ashore by dinghy than at any other time, so...

Wear lifejackets.  
Do not overload the boat – make two trips if necessary.



Carry oars, the dinghy pump and spare fuel for the outboard, just in case.

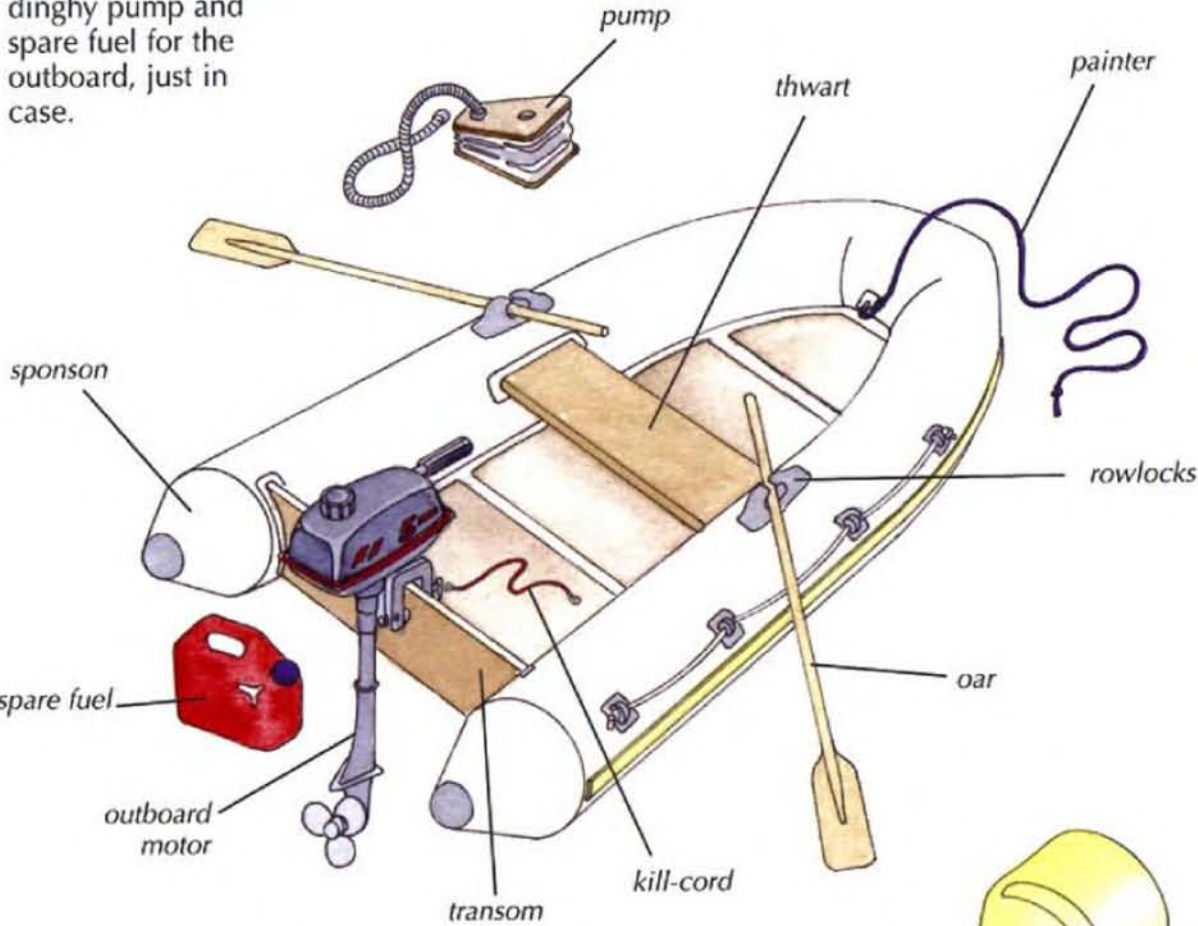

Have an anchor onboard.

Carry a box containing:

- tools
- bailer
- flares
- torch
- spark plug
- hand-held VHF



# USING THE DINGHY

Load the dinghy evenly.



Wear lifejackets and do not overload the boat.

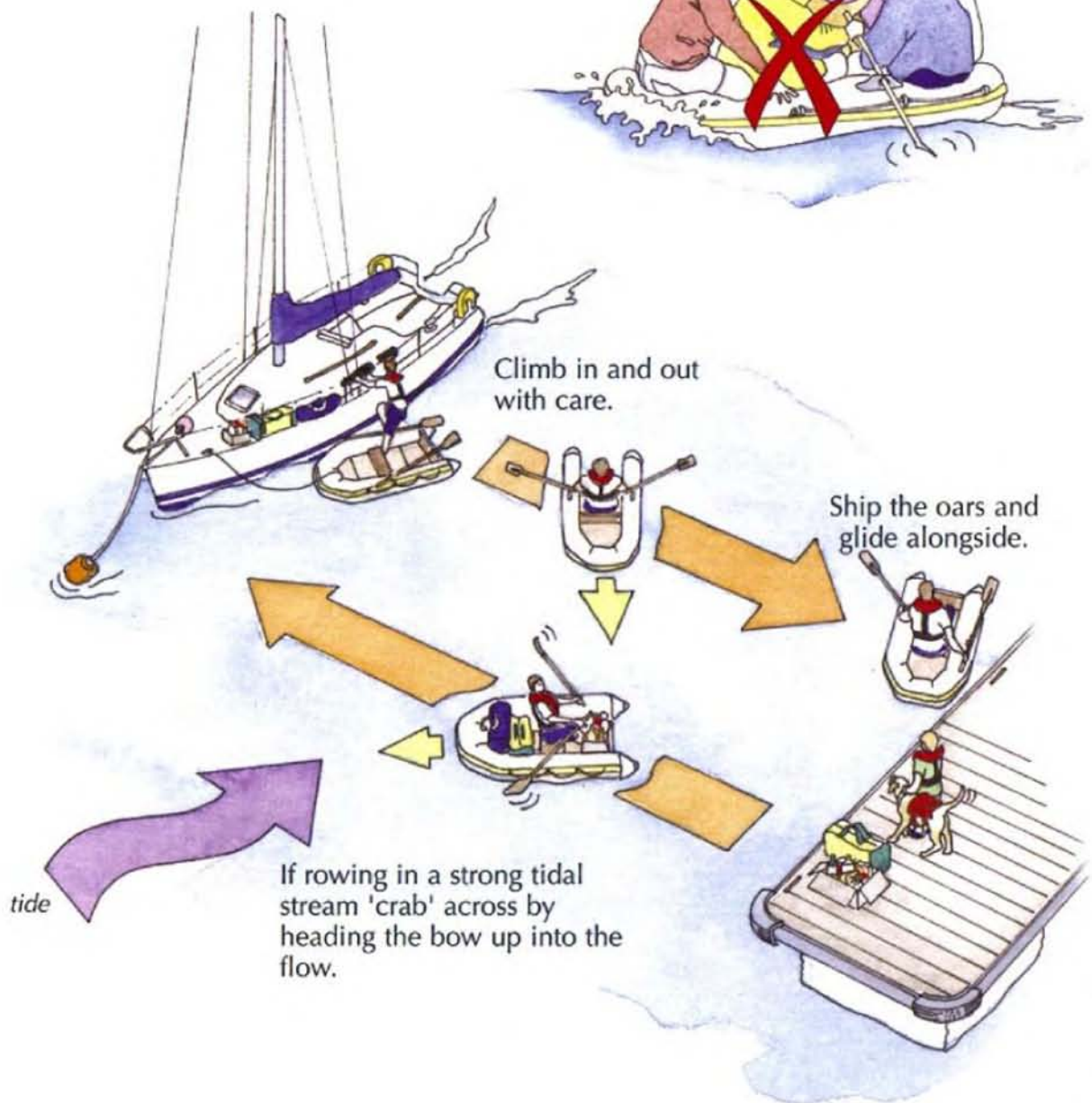

Climb in and out with care.

Ship the oars and glide alongside.

*tide*

If rowing in a strong tidal stream 'crab' across by heading the bow up into the flow.

## PERSONAL COMFORT

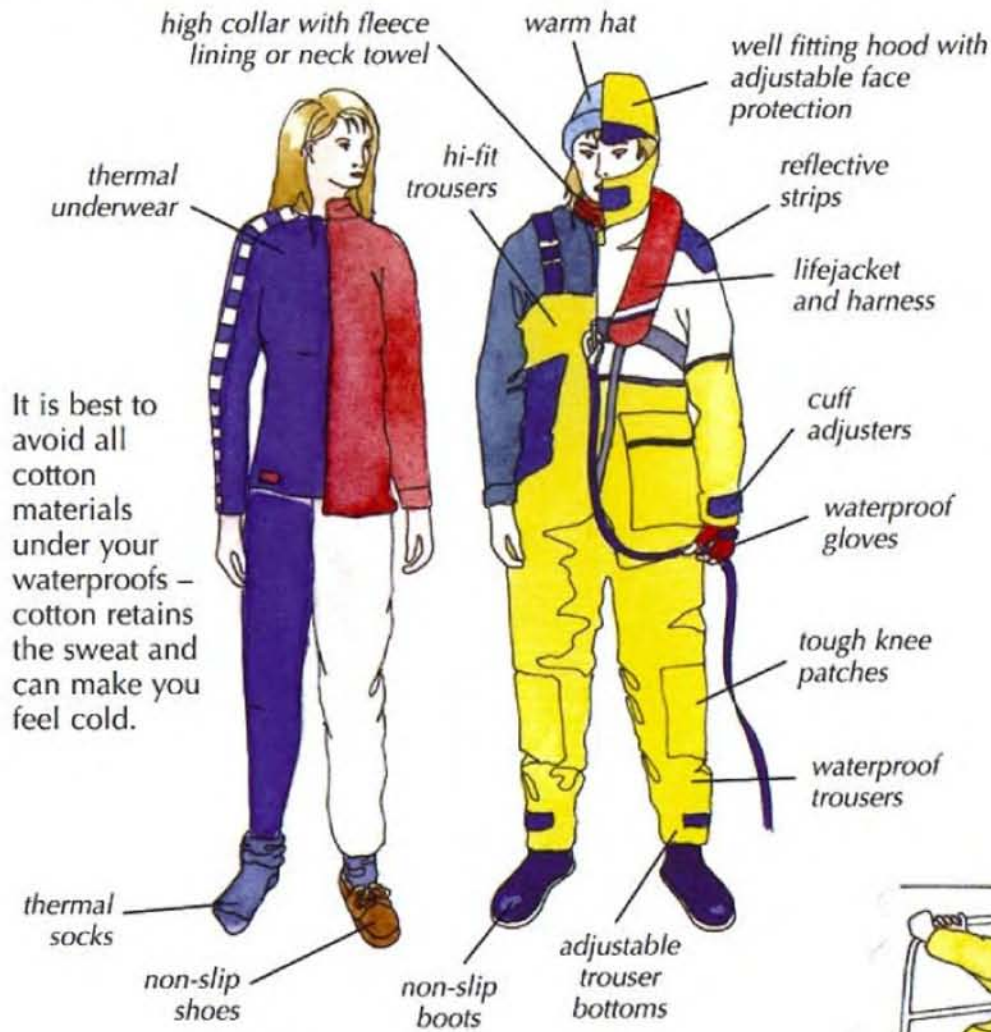

It is best to avoid all cotton materials under your waterproofs – cotton retains the sweat and can make you feel cold.



Use a hat, sunglasses and sunscreen to be protected from the sun.



To reduce sea sickness avoid alcohol and fatty foods before you sail.

Keep warm.

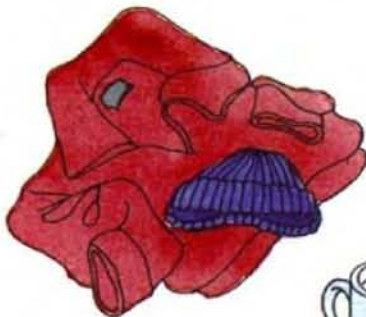

sea bands

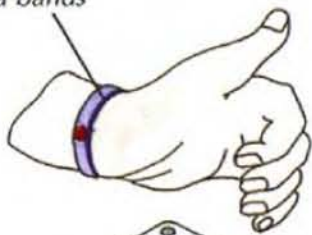

Drink water to avoid dehydration.



anti-seasickness tablets

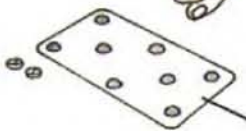

**Lifejackets**

A modern gas-inflated lifejacket combined with a harness can be auto-inflating. Use the crutch straps.



A lifejacket with integral buoyancy will give support to a conscious casualty who is able to swim. Extra buoyancy can be added by blowing into the valve.



DoT lifejackets found in ships and ferries can be bulky and uncomfortable to wear.



Children need special jackets to fit them.



Lifejackets that are too big or too loose do not provide support in the water and are dangerous. Use crutch straps to keep the jacket down.

**Harnesses**

Adjust a harness to fit you properly. It must fit tightly to be effective.

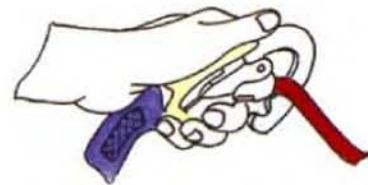

Clip on to the jackstay on the windward or 'uphill' side of the vessel before leaving the cockpit.

- Clip onto:
- Jackstays
  - D rings
  - Shrouds and stays
- Don't clip onto:
- Ropes
  - Guardrails or anything else

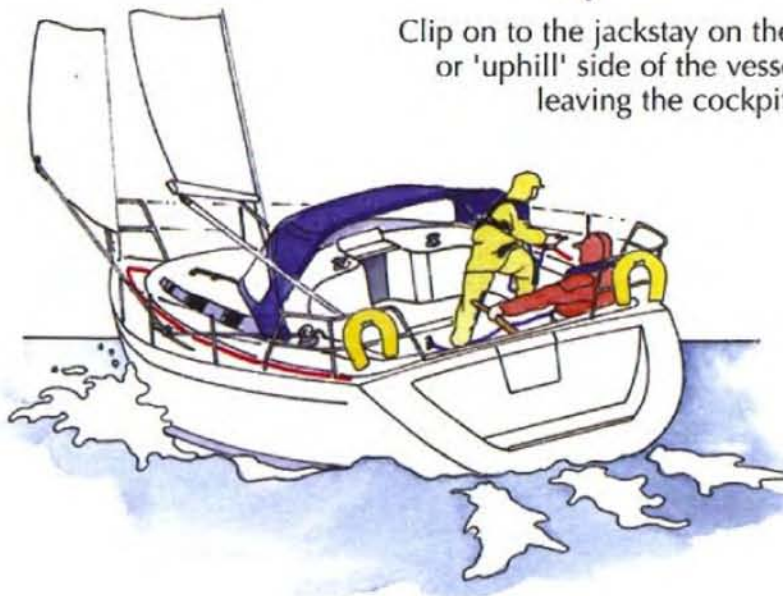

## MAN OVERBOARD- ACTIONS TO BE TAKEN



- 1 Shout "man overboard"  
Point at the casualty in the water.



- 2 Throw a life-belt and danbuoy.



- 3 Don't take your eyes off them and keep pointing.



- 4 Prepare a throwing line.



- 5 The skipper will come alongside, boat pointing into the wind, propeller stopped. Get a line around the casualty. Bring them aboard via the stern or boarding ladder - or use the halyard and winch them on board.

# FIRE

## Common causes of fire

Smoking below decks



Solvents/paints stored below



Gas build-up in the bilges



Faulty wiring

## Extinguishers

Dry powder – don't use on flammable liquids.  
CO<sub>2</sub> – good for enclosed spaces.  
AFFF - foam, good for flammable liquids.



Fire blanket – good for smothering flames.

Fire blankets can be used to smother a galley fire...



...and they are also essential for clothing fires.



Splashing water from a bucket can be more effective than throwing its entire contents at once.

## Fighting the fire

Aim the extinguisher at the base of the flames.



Cooking fats





## MAYDAY

Only make a Mayday call if there is 'grave and imminent danger' to person or vessel.

Use

- Channel 16
- High power

Press button on microphone before speaking – release it after the word "over".



VHF /  
DSC set

### VHF/DSC ALERT

Press the emergency button for five seconds to send an undesignated distress alert.

Voice message

### MAYDAY CALL

"MAYDAY, MAYDAY, MAYDAY  
This is yacht *Puffin* (repeat x 3)  
MAYDAY yacht *Puffin*"

### MAYDAY MESSAGE

"MAYDAY yacht *Puffin* (MMSI)  
In position (give latitude and longitude from GPS)  
Nature of distress  
Require immediate assistance .... persons on board  
Other VITAL information (abandoning to liferaft/have no liferaft) OVER"

## OTHER DISTRESS SIGNALS

### Buoyant Orange Smoke

- Daylight use only
- Use within 3 miles of rescuer
- Throw downwind



Cloud lasts 3 or 4 minutes.



### Orange hand-held smoke

Cloud lasts about 1 minute.

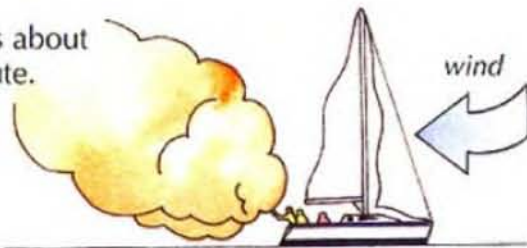

Orange smoke is easy for rescue helicopter to see.

Hold by the handle only – the metal casing gets very hot.

### Red hand-held flare



- Use day or night
- Within 3 miles of rescuer

Hold the flare downwind and horizontally to protect your hands.

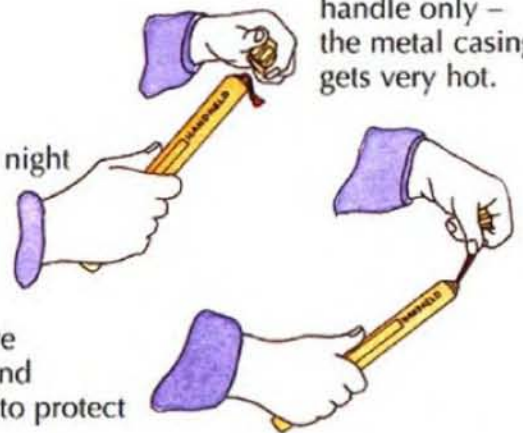

### Red parachute rocket



Remove cap

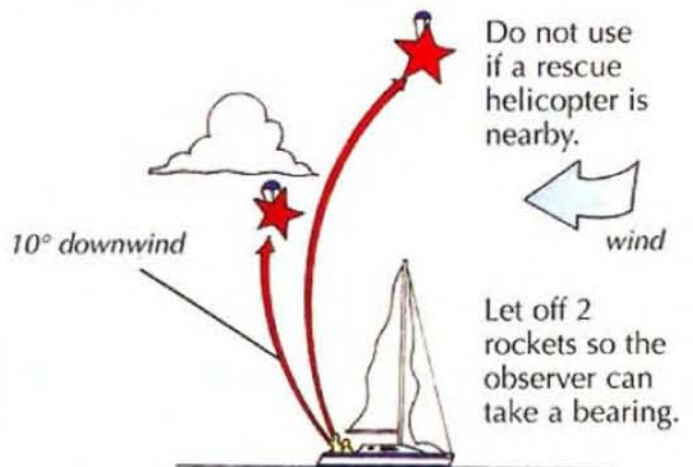

Do not use if a rescue helicopter is nearby.

Let off 2 rockets so the observer can take a bearing.

Read the instructions on flares and check they are in date.

## ABANDONING TO THE LIFERAFT

The liferaft should be stowed in a GRP canister on deck. Do not use it as a seat! With an HRU (hydrostatic release unit) it will deploy automatically if the boat sinks.

Only use the liferaft if there is no hope of saving the yacht. If possible stay with the yacht.

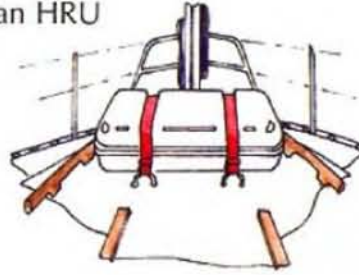

Stow a valise liferaft in a locker. Do not put other gear on top of it.

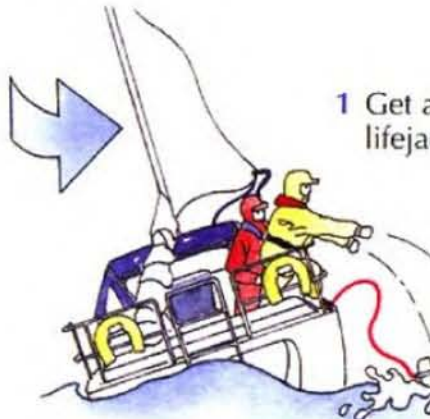
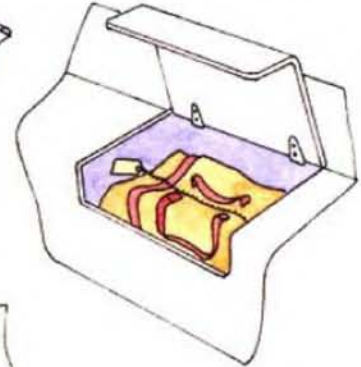

1 Get all the crew ready in their lifejackets. Send a Mayday.

2 Check the painter is tied on.

3 Launch the liferaft on the leeward side.

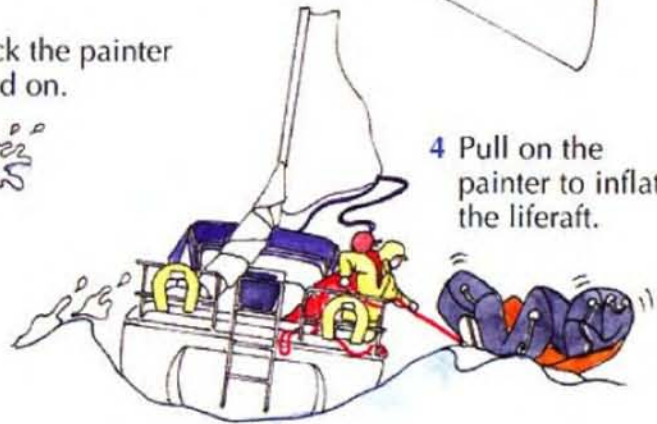

4 Pull on the painter to inflate the liferaft.

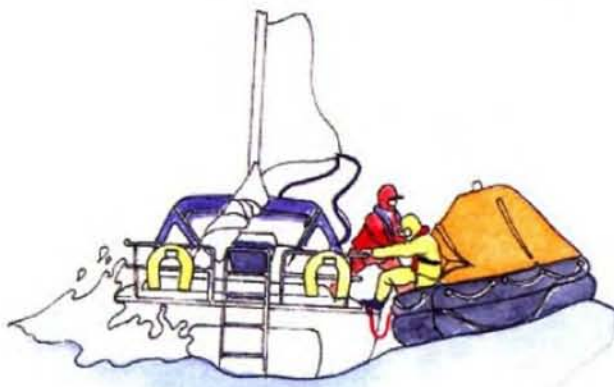

5 Get a heavy adult into the liferaft first for stability.



6 Get the crew to climb in, staying dry, if possible. Do not jump into the water.



7 Take extra things if you can – water, carbohydrate foods, first aid kit, warm clothes, sleeping bags, TPA (thermal protection aid).



8 Cut the painter and stream the drogue to increase the stability and reduce drift. Bale out any water. Take anti-seasickness tablets!

LIVING ABOARD

This is more suitable for a cruise liner than a cruising yacht.



Think carefully about the gear that you will need and pack it in a soft waterproof bag.

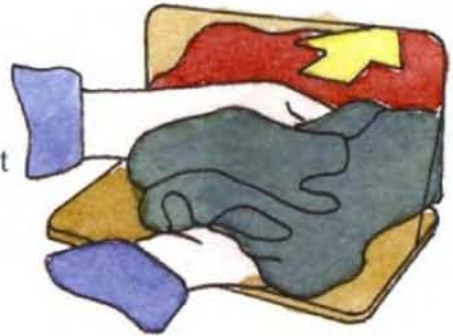

Turn off taps to save water.

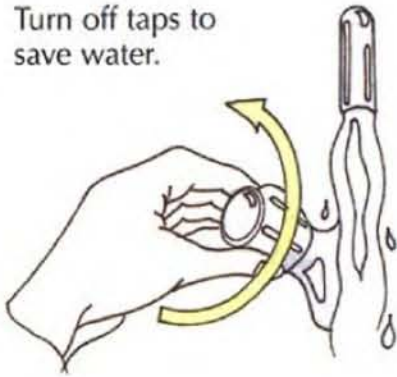

Switch off lights to save power and not to dazzle crew on deck at night.

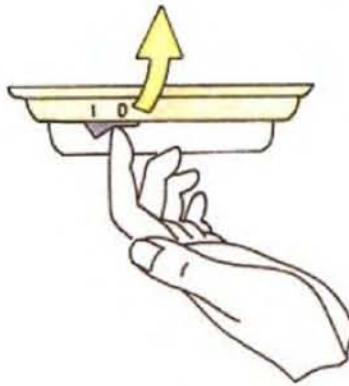

Clean up!

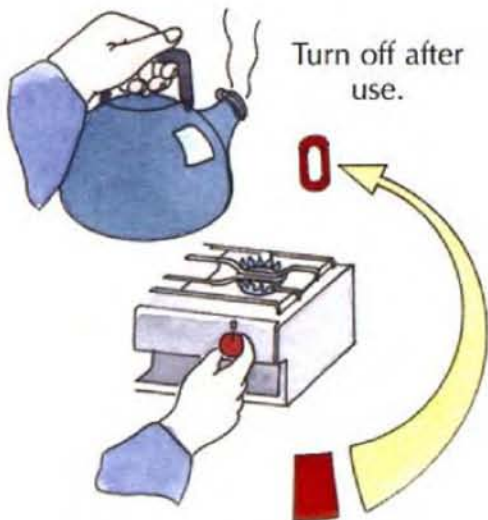

Turn off after use.

Don't leave the gas while it is lit.

Turn off at the tap away from the cooker.

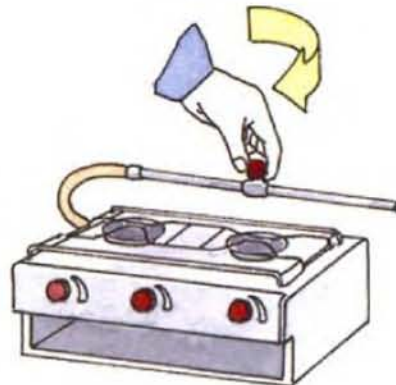

Turn off at the bottle.



## USING THE HEADS

There are many different types of marine lavatory (heads); the one shown below is fairly common. The skipper will usually show the crew how the heads work when you come aboard - if not, it's best to ask.

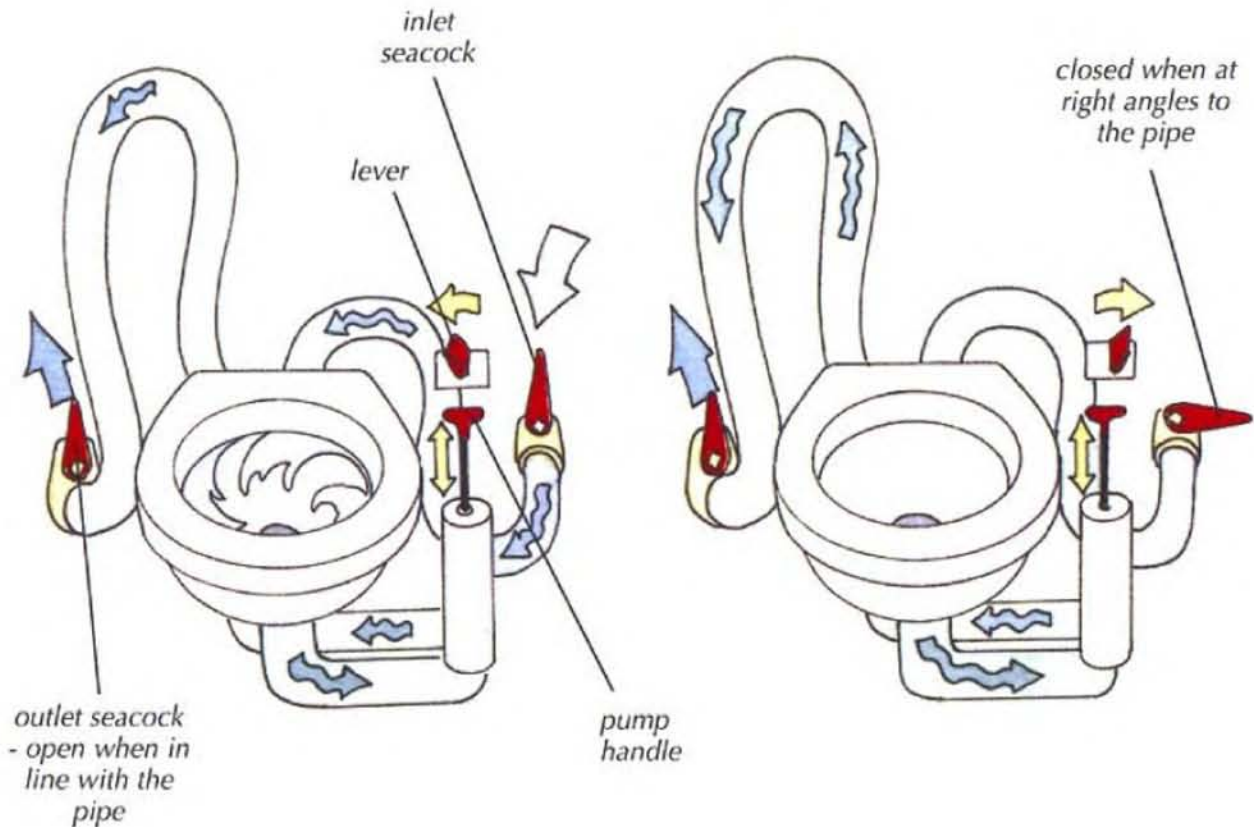

- 1 To flush, open both seacocks - inlet and outlet.
- 2 Move the small lever on the pump to the left and pump with the handle about 10 times to discharge the contents into the sea or holding tank.
- 3 Move the lever to the right and pump the bowl dry.
- 4 Close both seacocks.

Marine toilets rarely get blocked, if you follow the instructions.

However these are some things that will almost certainly block them.

Do not flush them.

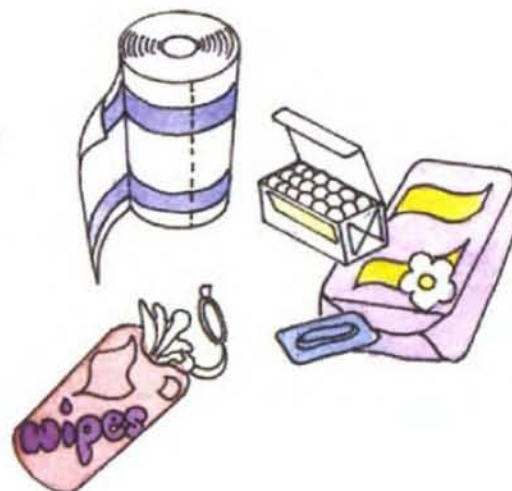

## LIVING AFLOAT

### Golden Rules At Sea

- Stow all gear securely
- Shut all lockers and hatches
- Put one chart only on the chart table with no drinks or wet gear



- Clean up spills in the galley immediately
- Put things away in the right place
- Don't waste water or power
- Don't disturb resting crew

# WEATHER FORECASTS

## Shipping Forecast Areas

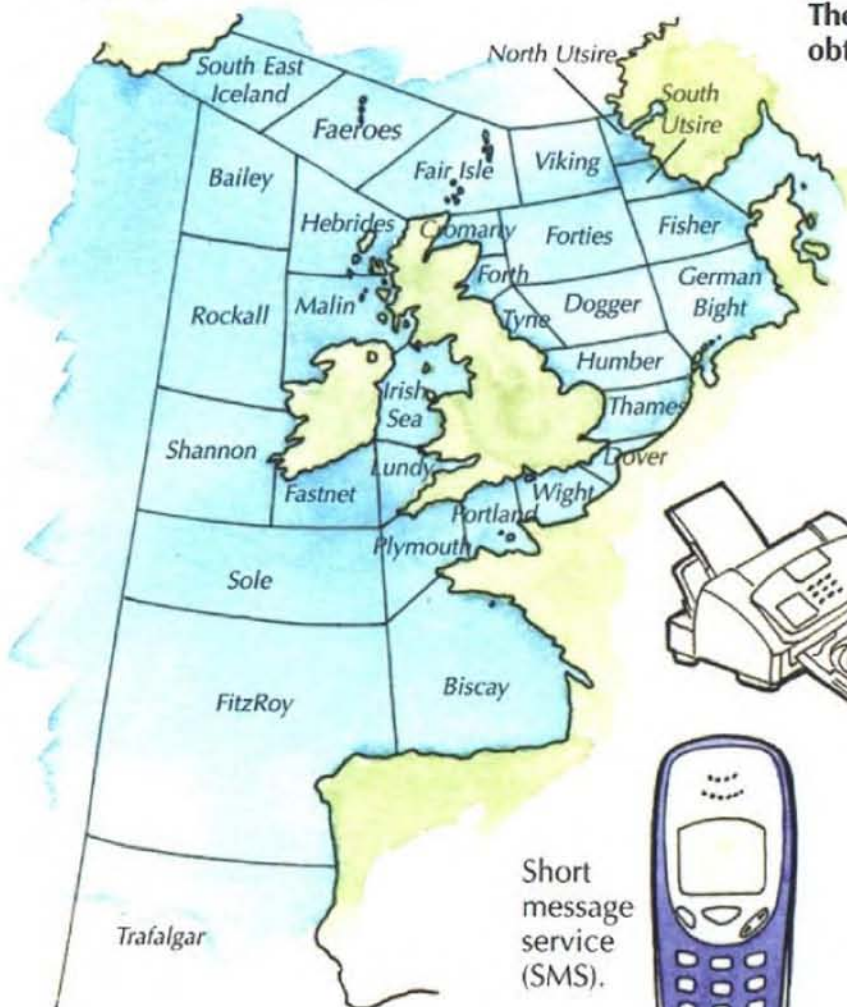

There are many different ways to obtain a forecast.



Maritime Safety Information broadcasts on VHF by Coastguard.

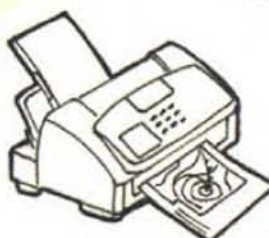

Metfax



Short message service (SMS).

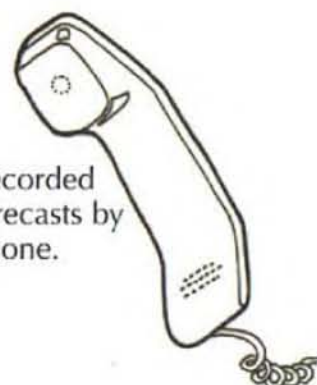

Recorded forecasts by phone.



Many harbour and marina offices post a forecast.

For details of forecast times etc. look in an almanac or the RYA book of *Weather Forecasts (G5)*

Internet

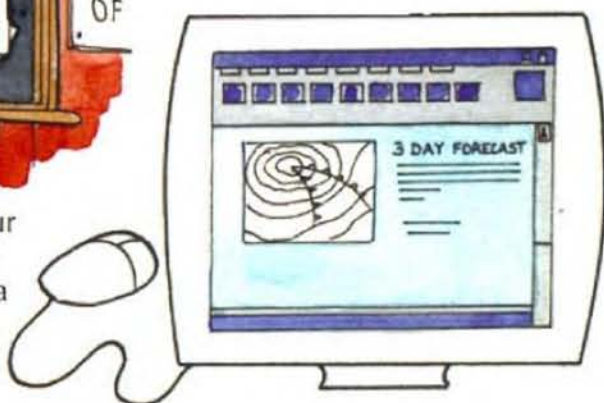

Teletext



Local radio stations.

## BEAUFORT WIND SCALE



- 1** **Light airs** 1 - 3 knots  
Ripples.  
Sail - drifting conditions
- 2** **Light breeze** 4 - 6 knots  
Small wavelets.  
Sail - full mainsail and large genoa
- 3** **Gentle breeze** 7 - 10 knots  
Occasional crests.  
Sail - full sail
- 4** **Moderate** 11 - 16 knots  
Frequent white horses.  
Sail - reduce headsail size
- 5** **Fresh breeze** 17 - 21 knots  
Moderate waves, many white crests.  
Sail - reef mainsail
- 6** **Strong breeze** 22 - 27 knots  
Large waves, white foam crests.  
Sail - reef main and reduce headsail
- 7** **Near gale** 28 - 33 knots  
Sea heaps up, spray, breaking waves, foam blows in streaks.  
Sail - deep reefed main, small jib
- 8** **Gale** 34 - 40 knots  
Moderately high waves, breaking crests.  
Sail - deep reefed main, storm jib
- 9** **Severe gale** 41 - 47 knots  
High waves, spray affects visibility.  
Sail - trysail and storm jib
- 10** **Storm** 48 - 55 knots  
Very high waves, long breaking crests.  
Survival conditions