

MAXIMUM SAIL POWER

**The Complete Guide to Sails,
Sail Technology and Performance**

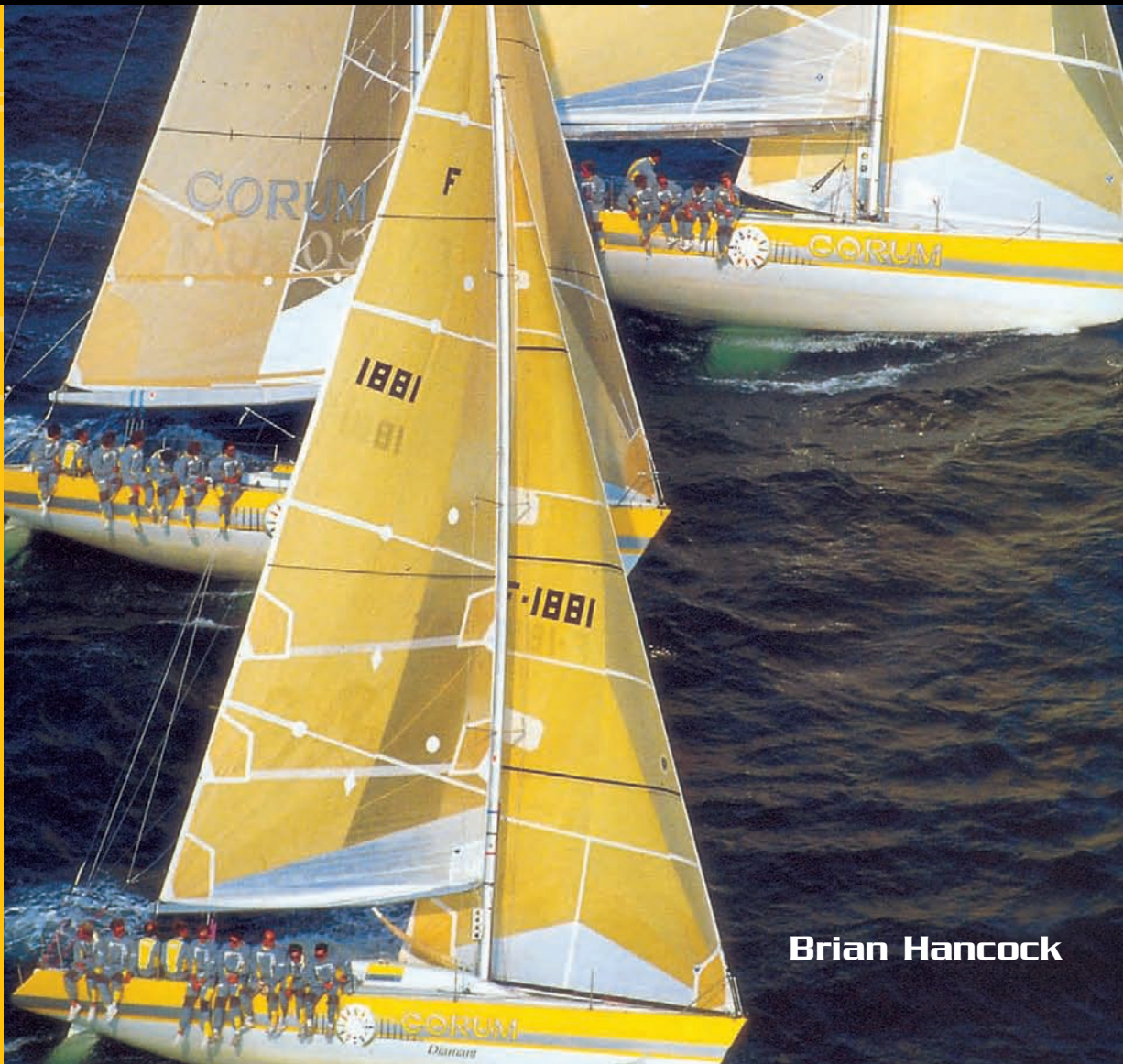

Brian Hancock

MAXIMUM SAIL POWER

**The Complete Guide to Sails,
Sail Technology and Performance**

Brian Hancock

Nomad Press
A division of Nomad Communications
10 9 8 7 6 5 4 3 2 1
Copyright © 2003 Nomad Press

All rights reserved.

No part of this book may be reproduced in any form without permission in writing from the publisher, except by a reviewer who may quote brief passages in a review.

The trademark "Nomad Press" and the Nomad Press logo are trademarks of
Nomad Communications, Inc.
Printed in the United States.

ISBN: 0-9722026-0-9

Questions regarding the ordering of this book should be addressed to
The Independent Publishers Group
814 N. Franklin St.
Chicago, IL 60610

Nomad Press, PO Box 875, Norwich, VT 05055
802-649-1995
www.nomadpress.net

All photographs, unless otherwise credited, by Brian Hancock.
Cover photo by ©Rick Tomlinson.

Brian Hancock is an expert in sails, sailmaking, and offshore ocean racing, having made a career as a professional sailor for almost three decades. He apprenticed at Elvstrom Sails in South Africa before leaving the country to sail around the world. In 1981/82 he sailed as a watch captain aboard the American yacht, *Alaska Eagle* in the 27,000 Whitbread Round the World race. Four years later he returned for a second Whitbread, this time aboard the British yacht, *Drum*. In 1989 he sailed as Sailing Master aboard the Soviet Union's first, and by happenstance last, Whitbread entry, *Fazisi*. With more than 200,000 miles of offshore sailing to his credit Brian is uniquely qualified to write about sails and the business of making sails.

Brian also owned his own boat, *Great Circle*, an Open 50 carbon-fiber, water-ballasted sailboat designed and built for single-handed sailing and Brian did a number of solo offshore passages. Some of his experiences are recounted in his book, *The Risk in Being Alive*, published by Nomad Press. These days he works on special sailing projects and writes for magazines around the world while raising a family in Marblehead, Massachusetts.

Dedication

For my father who taught me to sail, and for all my crewmates who have shared a watch with me

Acknowledgments

This book has been a fairly reasonable undertaking and it would not have been possible without the help and encouragement of the editors at Nomad Press. Many thanks to Alex Kahan for agreeing that this was a worthwhile project and encouraging me to go ahead with it. Thanks to Susan Hale and Lauri Berkenkamp at Nomad who patiently prodded me to make sure that the book got completed when more amusing exploits like sailing and skydiving had me distracted. And Jeff McAllister who did a terrific job laying out the book in an immensely readable fashion. Also thanks to the “nagger,” Adam Cort, whose diligence as an editor made this a far better book than I could ever have hoped to write on my own.

Mostly, however, I would like to thank my crewmates who sailed with me over the years and whose knowledge and expertise are contained in these pages, especially those who thought enough of what I had written to give the book their resounding endorsement.

It's gratifying to be acknowledged by your peers.

*Brian Hancock
Marblehead, Massachusetts, 22 August 2003*

George Day

*Publisher & Editor,
Blue Water Sailing*

“*Maximum Sail Power* is the best book on sails and sail trim to come along in a generation. Brian Hancock knows his subject and has the sailmaking experience and sea miles to know what really works and what does not out there on the open sea. If you are in the market for sails or want to become a better sailor, *Maximum Sail Power* will steer you straight and true.”

Herb McCormick

*Author, NY Times sailing writer,
editor of Cruising World Magazine*

“Brian Hancock is the rarest of seagoing creatures, a consummate sailor with countless miles in all conditions under his keel, and a gifted writer who can both spin a yarn and transpose complex technical material into clear, understandable prose. His *Maximum Sail Power*, a definitive treatise on the art and science of harnessing the breeze, joins a select handful of classic sailing books that deserve a space on the shelf of any well-found sailing vessel.”

Bernard Stamm

*Winner 2002/03 Around Alone
(Class 1)*

“Sails are not only the engine of the boat, but they are very important to the overall performance of the boat. Therefore it’s critical that you understand how they are made, and how to get the best performance from them. Brian’s book covers it all including how to trim and handle sails, and more importantly how to understand the subtleties of the wind and how it relates to sails. I know you will learn a lot from reading this great book.”

Brad Van Liew

*Winner 2002/03 Around Alone
(Class 2)*

“While Brian was writing this book he was also working closely with our team on *Tommy Hilfiger Freedom America* to develop the sail program and make a suit of sails that would not only win the race for us, but make it around the world in one piece. It’s clear that he knows his stuff. The sails performed perfectly and I never once had to worry about the design and engineering. All that knowledge and experience is contained in this book and I urge you to read it.”

Cam Lewis

*Olympic medalist, skipper of
Team Adventure*

“Brian was integral and a key team member in the sail development for the megacat *Team Adventure* and through his bountiful knowledge and global experience we were able to circumnavigate the world without any sail problems. Now his exciting new book contains that knowledge and experience from his decades of sailing and sailmaking – all you have to do is pick up a copy and read it. It’s clear that he knows his stuff not only for big catamarans but for more conventional race boats and cruising boats as well.”

“Brian Hancock does a beautiful job blending the art and science of sail technology. For most sailors, the theory of sails is a mystery. Brian makes it understandable for the club sailor, cruiser, and the racing expert. *Maximum Sail Power* makes the process of using sails and understanding their theory easy.”

“The mystery of how to obtain the best performance from your sails has been exposed. This book will be of inestimable value to the learner and experienced sailor alike. Sail trimming has always been considered an art. Brian Hancock has shown how it is a science.”

“Sails are the engine of any boat and understanding the principles of sail set-up and maintenance is crucial to good sailing. Brian’s book covers what you need to know about the subject. He has written a concise book in language we can all understand – you can tell Brian has a passion for the sport and masses of experience to share in both sailing and sailmaking.”

“Brian’s involvement with the sails on all my sailing projects from the early Whitbread races to my latest expedition sailing vessel *Pelagic Australis* has been integral to the success of each project. This is a storehouse of information that will be useful to the novice boat owner or the experienced cruiser/racer alike in order to demystify the “art” of sails, sail making and repair.”

“*Maximum Sail Power* is a well-written book by a well-known sailor. It is a comprehensive guide to how sails are made and work for all levels of sailors. Brian’s experience shines through in all aspects of his writing. This book is a must-read for all sailors.”

Gary Jobson

America’s Cup winner, ESPN commentator

Sir Robin Knox-Johnston

First sailor ever to solo circumnavigate the globe non-stop

Ellen MacArthur OBE

2nd place, 2000/01 Vendée Globe, UK Yachtsman of the Year

Skip Novak

Four-time Whitbread Round the World Race veteran, co-skipper of Innovation Explorer in The Race

Tom Whidden

President, North Sails

Table of Contents

How to Get the Most From This Book	x
Introduction	1
Chapter 1—A TRIP TO THE SAILMAKER	5
A hypothetical look at buying sails	
Chapter 2—IT STARTS WITH A YARN	13
A look at all the fibers used to make sails	
Chapter 3—FROM THREAD TO FINISHED FABRIC	25
How sailcloth is made	
Chapter 4—A PRIMER OF PANEL LAYOUTS	51
Different layouts for different fabrics	
Chapter 5—MOLDED SAILS	65
The latest sailmaking technologies	
Chapter 6—WHERE ART AND SCIENCE MEET	79
A look at the sailmaking process	
Chapter 7—THE DEVIL IS IN THE DETAILS	97
A close-up look at the individual parts of a sail	
Chapter 8—ALL ABOUT SPINNAKERS	125
Downwind sails explained	
Chapter 9—STORM SAILS	139
Techniques, tips, and some lessons learned	
Chapter 10—SAIL INVENTORIES	147
A look at what sails you need for your sailing purposes	
Chapter 11—THE FINE ART OF SAIL TRIM	157
How to get the most from your sails	
Chapter 12—SAIL HANDLING	191
Techniques for managing the unmanageable	

Chapter 13–A STITCH IN TIME.....217
Sail care and repair

Chapter 14–MORE QUESTIONS THAN ANSWERS.....229
A conversation with your sailmaker

Chapter 15–THE WIND IS STILL FREE.....241
The theory behind how boats sail

Appendix263

Glossary271

Detailed Table of Contents280

Basic Boat Diagram287

Index288

Photo by Roy Riley, Marinepics



Bobst Group Armor lux sailed by Bernard Stamm breaks through a wave shortly after crossing the finish line in Tauranga, New Zealand. Stamm went on to win Class 1 of the 2002/03 Around Alone race.

HOW TO GET THE MOST FROM THIS BOOK

Sails and sailmaking is a fascinating and increasingly complex subject. It's a combination of art, science, history, and mystery. Many sailors enjoy these complexities and spend days, sometimes weeks, even years studying the subject and using it to their advantage either on the race course, on a bluewater passage, or while out for a weekend cruise. Others find that it has become too complicated, too unwieldy, and far too difficult to understand. They feel overwhelmed by the enormity of the subject and view it as a large, kindly uncle whom they would like to know better, but whose presence is so imposing they don't make even the first attempt at getting acquainted. This book is designed to be your bridge between that unfamiliar world and your desire to know more about this important aspect of something you love. I feel strongly that an understanding of sails and the way they work is a part of basic seamanship and therefore important to all sailors.

While the weight of this book and depth of the topic might make you less inclined than ever to come to grips with the subject, the book is designed to lead you step-by-step through the process, making the journey as simple as possible. It's not necessary to read every word in each chapter. In fact, much of what is written might already be familiar to you, in which case you can skim those areas. It's also not absolutely necessary to read each chapter in order. You might find a particular part of the book that interests you, and if so I suggest you start the book at that point.

On the other hand, the book was written and laid out with a definite plan in mind, and if you start at page one and work your way through to the end a lot of what once seemed difficult to understand or too technical to grasp should become clear. It is possible to become a good sail trimmer without understanding the theory behind lift and drag, but you will definitely be a better trimmer if you understand how a boat sails and all the other nuances of sail design and handling. At the very least it will make you popular back at the yacht club. Who else bellying up to the bar will know about circulation, boundary layers, and lift, to say nothing of finite element analysis and how to carry out the perfect float drop at the leeward mark?

Maximum Sail Power is divided into a number of sections plus an appendix:

Chapter 1 is a hypothetical visit to a sailmaker. This chapter goes hand-in-hand with Chapter 14, which includes a series of questions that you might want to ask your sailmaker once you have a greater understanding of the subject.

Chapters 2–7 are the real meat of the book. They describe the process of creating a sail, starting with the raw materials and working through each step until the finished product is ready for use. The chapters cover everything from the basic properties of different kinds of fibers and the construction and engineering of fabric to the design and construction of different kinds of sails, including the latest molded sails.

Chapters 8–10 look at three important areas: downwind sails, storm sails, and sail inventories in general.

Chapters 11–12 are a comprehensive look at sail trim and sail handling.

Chapter 13 looks at sail repair.

Chapter 14, as already mentioned, is a question-and-answer section with all the questions you might possibly want to ask your sailmaker.

Chapter 15 examines the theory behind how boats sail, including an in-depth look at the aerodynamic and hydrodynamic theory behind how foils work and how a sailboat can sail close to the wind.

Again, you may choose to read only one or more sections of the book, although I urge you to make an effort to read them all, including the last chapter on sailing theory. I also encourage you to attempt to come to grips with some of the more complicated sail-handling maneuvers covered near the end of the book since the more you know about handling your sails the better sailor you will be. I have tried throughout the book to keep an even balance between racing and cruising. Rather than separate the two groups and address their specific needs independently, I thought it was important to keep them together, since cruising sailors can always

Photo by Mark Pepper, Marinepics



French sailor Thierry Dubois storms across the finish line aboard Solidaires in Salvador, Brazil, at the end of Leg 4 of the 2002/03 Around Alone race.

Bernard Stamm turned in an impressive performance aboard Bobst Group Armorlux in the 2002/03 Around Alone.



learn something from the racers and vice versa. If in parts of the book it appears that I am heading off on a subject that is not interesting to you as a cruising sailor, humor me and stick with it. You may learn something that can be applied to your cruising. Same too for racers. The experience of cruising sailors has contributed greatly to the sailmaking industry and as a racing sailor you might just learn something about durability and fabric engineering that can help you out on the racecourse. In its entirety, the subject of sails and sailmaking is fascinating. I hope that this book will give you a greater understanding of the topic and that you will derive more enjoyment out of your sails, and by extension, your sailing.

INTRODUCTION

In the fading light of a South African summer evening we took off from a small airfield and flew along the coast watching the bays and harbors unfold as we skimmed the treetops. A strong wind was blowing, lacing the ocean with white streaks of spin-drift and buffeting our small helicopter. Table Mountain cast long shadows as the sun dipped slowly over the western horizon. Where the water was shaded, the whitecaps stood stark against the dark sea, but toward the horizon they sparkled like small diamonds, reflecting the last light of day. As the cape peninsula tapered to its scenic point I could just make out the boat a mile off the beach crashing through steep waves. Spray was flying from both hulls as the 110-foot megacatamaran *Team Adventure* sliced through the water at 30 knots. She was heading for the Southern Ocean and beyond, to Cape Horn, the Atlantic Ocean, and finally back to France and the end of her voyage. We hovered a few feet above the top of the mast looking down at the sheets of water rising from each bow and pitied the crew hunkered on deck holding on for the ride of their lives. From my vantage in the chopper I could see both the clean twist of her mainsail and its smooth overall shape. Surprisingly, the thought that passed through my mind was, “trickle down does work!”

I was partly responsible for the sail development program for *Team Adventure* as she prepared for The Race, a nonstop circumnavigation of the world. It was a loaded responsibility since the success of the effort, indeed the safety of the crew, depended upon some of the decisions made before the start of the race. My realm was fabric: the myriad clusters of fibers, film, adhesive, and thread that collectively would harness the wind and propel the boat around the planet. Since the race was nonstop and the sails so enormous and unwieldy, there would be no way to repair any of them if they ripped or came apart. The mainsail that was bent on the boom at the start would have to remain in use until the finish some 27,000 miles later. Working with a number of sailmakers we tested all the usual suspects, including Kevlar, Spectra, Vectran, and carbon, each both alone and in various combinations. We also looked at some of the newer sail engineering techniques like North’s 3DL process, UK’s Tape Drive, and Doyle’s D4. In the end we settled on a revolutionary fabric called Cuben Fiber, which tested off the charts when compared to the others to the point where the numbers looked almost too good to be true. In fact, in some areas they were, but overall the fabric showed so much promise that most of *Team Adventure’s* sails were eventually made from Cuben Fiber. Of course, there was an element of risk involved. Cuben Fiber had never been used for a voyage of this nature before, a fact that alone should have disqualified it from consideration. But we compensated for this drawback by over-engineering the sails. And when the boat took off from Marseilles on the last day of 2000, everyone involved in the sail development process was satisfied that the sails would not only go the distance, but also provide the crew of *Team Adventure* with an edge over its competition.

As fate would have it, it was an engineering problem associated with equally exotic fibers used for the construction of the hull, not the sails, that forced the boat

“ . . . we tested all the usual suspects, including Kevlar, Spectra, Vectran, and carbon, each both alone and in various combinations.”



Considered the world's fastest sailboat, Team Adventure is 110 feet of pure power capable of sailing at 40 knots.

to make an unscheduled stop in South Africa. When I flew to Cape Town to coordinate the repair of the boat, I saw that even after a little over 10,000 miles of use the sails still looked like new. Aside from some opaque crinkles in the laminate from being stuffed into a bag, the “risky” fabric we had chosen seemed to be performing beyond expectations. As I checked the sails and talked to the crew, I realized that the design parameters outlined for these sails would be the same for just about any inventory of sails that might be used for an offshore passage – light sails that hold their shape and have sufficient durability to circumnavigate the world without stopping – and that I might very well be looking at the future of cruising

sails. This feeling was further reinforced that evening as I watched *Team Adventure* plunge from wave crest to trough. I felt sure that one day in the very near future we would be seeing Cuben Fiber sails on some of the larger cruising yachts, perhaps even on smaller ones as the fabric became more accepted. The technology developed and tested at the “lunatic” fringe would one day “trickle down,” to use a phrase that President Reagan made famous, to the average cruising sailor.

It's this trickle-down process that has served to intrigue and confuse many sailors out there looking for sails for their own boats. Years back the choices were simple: Dacron for mainsails and headsails, and nylon for spinnakers, all of them constructed in pretty much the same fashion. Because of the way Dacron was woven into sailcloth, the sails were built in a cross-cut style with long panels of horizontal sailcloth running from the luff to the leech. The same was true for the early spinnakers. That, however, was a simpler time in more ways than just the sail-making process. These days it's a complicated world made more so by the increasingly competitive nature of the sailmaking business. One sailmaker will be adamant in his recommendations, while another will be just as definite about something completely different, both making recommendations for the same application. The reality is that both may be right. There are many ways to make an equally good sail and even that old standby Dacron has a role to play in the modern sailing world. In fact more than 70 percent of all new sails currently being manufactured are built from Dacron. The hard part for the individual sailor is deciding which way is right for him. What is it exactly that he or she needs in the way of sails? How do they fit within a given budget, and equally important, how do they fit within proposed sailing plans? These are individual choices unique to each sailor, but this book will go a long way toward helping you, the reader, understand what will best suit your needs once you have decided what they are. You will come to understand how different fibers and fabrics might work on your boat, and how to best invest your hard-earned money. It's a complex subject that is fascinating to

Close racing at Block Island Race Week.



some and frustrating to others. It's my job to lead you through the process, at times getting you wet when we take leave of the technical work and go sailing, but along the way we will unravel the complexities of this complicated, yet uniquely interesting, subject. My hope is that some of the passion and practical experience I have gained from years of sitting on the side of a boat gazing up at the sails will rub off on you. Most of all I hope that you will be better informed and able to make the appropriate decisions the next time you are shopping for sails for your boat.

This book starts with a hypothetical visit to a sailmaker. Use it as a guide for your own sailmaking experience. These days sail-buying choices are so vast it's impossible for me to dictate precisely what you should or should not do when it comes to choosing a sailmaker. In the end it's an individual decision. But, if you do your homework and take the time to understand the subject, you can get just as good sails from your local mom-and-pop sailmaker down the street as you can from a globe-trotting sailmaker working for one of the big franchises. Shop around, compare prices and details, and remember one important thing: There are many different ways to make the same sail and all of them may result in an excellent product.

Chapter 1

A TRIP TO THE SAILMAKER

A Hypothetical Look at Buying Sails

It was not so many years ago that buying a new sail for your boat meant a pleasant trip down to your local sailmaker. You made a call (e-mail was not yet invented), set up an appointment, and then spent a few wonderful hours looking at bolts of cloth, talking boats, and settling on a price. If you were a good customer a handshake would seal the deal, the sail would be made, and a few weeks later it was delivered to your boat an invoice would arrive by mail. Your sailmaker knew you by name – both yours and your boat’s – just as your family doctor knew your medical history. More often than not the sailmaker would bend the sail on personally, take the boat out for a sail to check the fit and cut of your new purchase, and generally treat you like, well, a customer.

Those days, however, are long gone. We live in a much more technically advanced world where even important purchases like a new sail are done via e-mail, phone, the Web, or some other “convenient” means. Old-fashioned service is gone, unless of course you are spending upward of fifty thousand dollars, and that’s not necessarily a bad thing, since then, as now, that service didn’t come cheap. True, you want the sail to fit right, look good, and perform well, but you also want all these things at a reasonable price. For a sailmaker, spending the afternoon out sailing with a customer, while a pleasant experience for both parties, is costly, and that cost inevitably has to be added on to the price of the sail. These days, with modern fabrics, computer technology, and vast databanks of empirical information, the chances of a sail not fitting perfectly and looking good the first time out are becoming increasingly remote. In fact, the truth is that today you really don’t need to know your sailmaker personally, nor do you need a personal visit and sail check to ensure that everything came out as designed. The world has changed, and so has the sailmaking industry. In some cases you are now able to simply “add one to your shopping cart” with the click of your mouse, and have the sail show up via FedEx a few weeks later.

Still, for all the high-tech, some aspects of sail buying remain the same, including the fact that the process starts by asking the right questions. This includes you asking the sailmaker questions, and the sailmaker asking you questions. You also need to ask yourself some hard questions like, “what kind of sailing will I be doing over the next couple of years,” and “do I really need the latest molded sail from the most expensive fabric available when the experience level of my crew is questionable?” Remember, a sail is an expensive purchase and you need to be clear about what it is you are buying. If, for example, you are thinking about entering your boat in the Newport to Bermuda Race in two year’s time, does it make sense to save a few dollars buying a new Dacron headsail because it’s all you can afford when you know that an investment in fabric and engineering will pay long-term dividends? Perhaps instead of the Dacron sail

“For a sailmaker, spending the afternoon out sailing with a customer, while a pleasant experience for both parties, is costly, and that cost inevitably has to be added on to the price of the sail.”



Some sail lofts, like the Doyle loft in Marblehead, Massachusetts, are in scenic locations making a trip to the sailmaker a very pleasant experience.

you could have your current sail recut, and in a year's time buy the laminated sail, which will still be fairly new when the race starts.

It is also important to articulate to your sailmaker what it is you expect from your sails. For instance, is out-and-out performance your goal, or are you willing to trade some performance for durability? Maybe sail handling is more important than sail shape. For a cruising sailor used to physically changing sails, the feel of the fabric might be more important than the cut of the jib, and a soft, tightly woven Dacron may be a better choice than a stiff, highly resinated one. Whatever the choice, the process starts by asking good questions. Sails are tailor-made items, and just like ordering a new suit, you should not decide on the first color you see. Do your homework and you will be more pleased with the results. And your sailmaker will be happy to know that he has satisfied a customer.

An educated customer is a sailmaker's best customer, which is where this book comes in. By the time you have finished the book you will have an understanding of what it takes to design and build modern racing and cruising sails. If you have an understanding of the different fibers, fabrics, and engineering details like the number of reefs you need or whether or not you want a cunningham in your headsail,

it will be a lot easier for your sailmaker to make you the sail you want. You should also talk to other sailors with similar boats, sailors with different boats, and a number of other sailmakers, since it's not only their job to sell you their product, but to make sure that you get what you want and not what they want you to have. Throughout this process remember this very important point: There are any number of ways to make the same sail, and in most cases they will all be good. There are, for example, various styles of fabric made by different fabric makers that will all do an equally good job, so don't get too concerned if two different sailmakers recommend two different types of cloth. Ask about the merits of each kind, but don't assume that one has to be "bad" and the other "good." By the same token, brand loyalty is good, and if you've had a good experience with a certain fabric maker then that's a good reason to ask for its product again. Sailmakers, fabric makers, and hardware makers appreciate loyalty, and the result will be a better sail for you.

Sailmakers need lots of important information from you if they are to do their job, so be sure that you are ready to provide it. They need to know, for example, if you plan to mostly race or cruise. They also need to know if you are daysailing or heading offshore, and in what region of the country you will be sailing. These days a lot of sail buying is done over the phone and a sailmaker located on Long Island Sound, where the summertime winds are light and variable, might not know that San Francisco has a blustery afternoon breeze that kicks up a short chop. This would be a valuable piece of information if you are a West Coast sailor and want your sail to be designed and engineered to suit the local conditions. A sail designed for use in choppy inshore waters will have a different shape than one used in long ocean swells offshore.

Once you have established the kind of sail you want, it's time to move on to the next very important step: information about your boat, i.e., its dimensions and the exact size of the sails needed to fit the rig. Rule Number One: Assume nothing, on both sides. It's not enough to tell the sailmaker that you have a Beneteau 345. There are six models of Beneteau 345 and they all have different rig dimensions. If you are not sure whether you have the tall or short rig, you must find out before the sailmaker even works up a quote. Be specific about which model you have and, equally important, know exactly what year the boat was manufactured. For example, a C&C 27 built in 1984 has a different boom length than a C&C 27 built in 1985. Also remember that some boat manufacturers offer different boom or hardware options, for example, either a conventional or a wishbone boom. You also need to tell your sailmaker if you know of any modifications done to the boat. Perhaps a former owner lengthened the boom or raised the lifelines; or maybe there is a whole new sporty rig on the boat. Small details like the height of your lifelines will have a bearing on your new sail. If it's a cruising headsail, the sail designer will want to be sure that the foot of the sail clears the lifelines so that it does not chafe. If it's a racing headsail the clew height will be placed so that it does not hang up on the lifelines each time you tack.

The same points apply to the rest of your rig. If you have a furling unit, make sure your sailmaker knows the make, model, and year of the unit. If the deck lay-

“Different fabrics from different manufacturers built by different sailmakers can make for equally terrific sails.”

out has changed be sure to make that information available. In the Appendix of this book you will find detailed measurement forms and a step-by-step guide that walks you through the process of gathering this all-important information. It’s a worthwhile exercise to take the time to carefully measure the mast, boom, and deck layout, including details like mast-bend characteristics. If you know you have a specific make and model of boat and you know nothing has been changed, then maybe you can feel confident about providing only this information. Otherwise, take the time to take the measurements. Sailmakers work on the same principal as carpenters: measure twice, cut once.

Once the leg work has been done and you have had detailed discussions with various sailmakers and gathered all the relevant information about your boat, it’s time to get a quote; actually a number of quotes, since even if you have a good relationship with a sailmaker it’s a good idea to get prices from a number of manufacturers to see what the market is like. Be honest with your regular sailmaker if you have one and tell him that you are asking around for some other prices. Also be frank about what is most important to you in terms of price, performance, and durability. If, for example, you are strictly a bottom-line person then tell the sailmaker that you want the lowest price and that you will be making your decision based upon this single criterion. Perhaps you place more emphasis on service, durability, or warranty, or any number of other reasons. Be sure that each sailmaker gets the identical information from which to generate your price. It’s in your interest to be able to compare apple against apple quotes from the various sources.

At this point it’s important to note that there are some great web sites you can go to that will give you an instant quote. You simply feed in the boat make and model, or the rig dimensions, and seconds later the price comes up on your screen. For standard boats and standard sails, say an asymmetrical spinnaker for a Beneteau 27, you can get an instant quote and, should you order the sail, it will be no different than had you paid a personal visit to your sailmaker. It gets a bit more complicated when you are talking about a mainsail or a headsail since your sailmaker needs to know more about you and your requirements than you can feed into a computer program. The online quoters, for example, do not ask you if you want to trade performance for durability. Nor do they ask you where in the country you plan to do your sailing. Still, these quotes are useful for getting a quick idea of what the sail specification and price will be, and provide a good reference point when you call the sailmaker and begin the discussions talked about earlier in this chapter. These same web sites also offer a lot of useful information about their sails, fabric suggestions and other relevant information, which again makes it well worth your while spending some time on line doing your homework before you start discussions with your sailmaker. The industry has become complex and is also rapidly changing, so some quick research will pay great dividends as you get into the real meat of your discussions.

Once you have your sail proposals back from the various sailmakers, it’s time to take a closer look at what has been proposed. Again, it’s important to remember that there are many ways to make a great sail. Different fabrics from different

manufacturers built by different sailmakers can make for equally terrific sails. If you have a number of proposals it might be useful to place the relevant information in a spreadsheet so that you can compare. List items such as fabric choices, fabric weight, sail area, and sail details like the number of reefs, the edge treatments, the warranty, and any other important piece of the puzzle. By having this information in a spreadsheet that you can view at a single glance, you will soon see if one sailmaker is off on his calculations; say a sail area that might be a lot more than the other proposals or a price that is too high. Maybe a call to that sailmaker to check his information will result in the area being changed along with the price. Then again it might yield an interesting new approach in terms of the construction of your sail. Be aware that sailmakers use different methods for calculating things like sail area. With headsails, for example, some simply calculate the area of a triangle and use that information, while others will take into account leech hollow and foot round, so don't be concerned. Same for mainsails: Different sailmakers, for example, may factor in a different percentage for the amount of roach on the sail. In general it's good to look at these numbers to see if there is one that stands out as potentially being wrong, especially since the two main elements that go into the cost of a sail are the amount of materials being used, fabric in particular, and labor. Spinnakers are most certainly an area where you will see big differences in sail areas and by extension the prices of the sails, so be sure to pay careful attention to those numbers.

In this same vein, you should also pay close attention to fabric recommendations. It's likely that you and the various sailmakers will have already discussed the basic fabric for the sail, be it Dacron or Pentex or something more exotic, so if all the proposals come back with similar fabric choices that's a good thing. If one sailmaker has something completely different it might be a red flag, although on the other hand it may be that he has the fabric on his shelf, wants to get rid of it, knows that it will work fine for your sail, and is adjusting the price accordingly. Again this information is just a guide. If four sailmakers suggest 9.2-ounce Dacron for your mainsail and the lowest quote is for a 7.7-ounce Dacron, then maybe it's not worth taking the lowest price. Heavier fabrics cost more than light fabrics and you should also know that there are many different grades of Dacron. In Chapter 2 you will learn about what goes into top-quality Dacron, but for now be aware of this fact and be prepared to ask your sailmaker what fabric he plans to use to build your sail. If you read this book before you talk to your sailmaker you will be able to dazzle him with discussions about yarn quality, yarn content, and types of finishes. Otherwise, just be aware that there are subtle differences.

Once you have done your homework it's time to go back to the sailmaker and raise any remaining concerns you might have, especially with regard to price. Sailmaking is a competitive business and while sailmakers want your business, they know their margins and where there is room for negotiation, so you may be able to work out some kind of compromise. You should know that there is usually a 50-percent markup on sails, which results in a 33-percent profit, giving most builders a little room for flexibility. Bear in mind, however, that there is a fine line

“Sailmaking is a competitive business and while sailmakers want your business, they know their margins and where there is room for negotiation . . . ”

“Once you take the plunge and actually order new sails, you should understand that sails take a long time to build.”

between astute negotiating and simply playing one sailmaker off against another in a bid to save a few bucks. Among other things, the second method will probably end up with you on the losing end in the long run, since you will get what you pay for. By this I mean that if the sailmaker has been bargained down in a fight for the lowest price, he may be tempted to cut a few corners when the sail is being built. There are cheaper grades of fabric, for example, that look much the same as the better ones, and you might get your sail made from one of them. You will only find out down the road that you bought an inferior product.

One way in which you and your sailmaker might work together to the advantage of both is to ask if he can get his hands on any “seconds,” in other words fabrics that for some reason are not 100-percent perfect. When the fabric makers do a final check of each bolt of fabric, they mark areas where a thread is not perfectly straight or a drop of oil might have marked the surface. Neither of these flaws will have any bearing on how the fabric will perform, but the fabric makers do not want to be seen putting out anything but a perfect product, so they will mark these blemishes as seconds. Your sailmaker, with some judicious planning, can bury an oil stain or misaligned thread under a reef patch or corner reinforcement. All of the sails on my own boat were made using seconds, and it saved me a lot of money.

The next thing for you to consider are the details that will go into your sail like the number of reefs, a foam pad up the luff of a cruising headsail, or an ultraviolet cover down the leech. These items add to the cost of a sail, and while in some cases they are absolutely necessary, in others you can just as well leave them off and the sail will be fine. As an example, unless you are heading offshore, or you sail in an area where it is especially windy, you probably won't need that third reef since more often than not two or even one will be fine. You also may or may not want an overhead leechline on your headsail. If you can reach the clew of the sail standing on the deck, why pay for the leechline to go over the head of the sail and down the luff so that you can adjust it at the tack? In short, once you get your proposal and quotes, go over each item and decide on a case-by-case basis if you really need it. These details not only add to the weight of a sail, but also to the expense, and money saved in one place can be spent elsewhere.

Once you take the plunge and actually order new sails, you should understand that sails take a long time to build. In later chapters we will discuss the amount of effort and energy that goes into designing a sail and the fact that each sail needs to be individually designed, even if it's a stock sail, since it needs to be tweaked to suit your requirements and the conditions where you sail. And that's just the beginning in terms of what needs to be done. If the sail is to be made from a custom fabric, the sailmaker might have to wait for the fabric maker to manufacture the fabric before he can start work. And if you are buying molded sails there is a chance that the necessary equipment will be tied up with other orders. In short, it's in your interest to give the sailmaker plenty of lead time, and if at all possible, to avoid new sail purchases in the spring when everyone else suddenly remembers that they need that new racing headsail and the season starts in three weeks. In fact, your

best bet is to take advantage of fall specials or to find a time when business is slower than normal to order your sail. Not only will you get better attention to detail, you will also get a better price, since a production facility needs to build products to keep the workers working. Remember, however, to use this leverage judiciously, since again, you get what you pay for.

Which brings us to the final point: the warranty. These days, with modern materials and computer-aided design, it's not unrealistic to expect five to seven years or even more out of a sail. In other words, if you have chosen your fabric carefully, had the sail built by a respectable sailmaker, and treated it well, you should have plenty of worry-free enjoyment from the sail. As a result, a sailmaker that offers a three-year warranty knows that he is on pretty safe ground. In fact, even Airforce Sails, which offers a five-year warranty, the longest in the industry (something I urged the company to do when I was working there as a consultant) has little to worry about, since the problems that arise in a new sail generally do so in the first few months. Issues like not fitting properly, for example, are immediately obvious and should be taken care of right away. Other problems that may arise are more than likely going to have to do with faulty fabric, in which case sailmakers are often able to go back to the fabric makers and get the fabric replaced. Then it becomes an issue of who pays for the new sail to be built. If it was an experimental fabric or one that you insisted on having the sail built from, then some of the responsibility should be shouldered by you. On the other hand if you stayed at arm's length from first to last then the problem rests with the sailmaker and fabric maker. Fortunately, since they have a relationship that needs to be preserved, they will work it out equitably between themselves. You can and should expect that the cost of a replacement sail be prorated a little. If after two to three years you end up getting a new sail because the old one delaminated, you should feel obliged to pay something toward the new sail. You will, after all, be ending up with a brand-new sail and presumably a brand-new warranty.



Most sailmakers will let you stroll around the loft floor so that you can watch sails being manufactured. Here a logo is being applied to a mainsail.



Sails come in all shapes and sizes, but sometimes they are the same as illustrated by this fleet of J-44s.

So that is pretty much the sail-buying process. There can inevitably be some small things that go wrong, but all in all you should expect your new sail to show up just as you ordered and on time. If you are at all concerned about having your new inventory of sails arrive in time for the launching of your boat, by all means write a performance clause into the sail purchase contract, since nothing gets a sailmaker's attention like the possibility of losing money because of late delivery. With most orders it's standard practice to make a 50-percent down payment when you order sails and the balance before you receive them. A percentage of the balance can be withheld pending successful fitting of the sails and sea trials, but be fair on all accounts. You want your sailmaker to be there for the long run and you also want your new sails to be right. In the end it may require a bit of give and take.

Chapter 2

IT STARTS WITH A YARN

A Look at All the Fibers Used to Make Sails

In your mind's eye, try to imagine the wind flowing across your sails. If you have telltales, those small, light pieces of yarn or fabric attached to the surface of the sail, they will flutter in the air stream, dancing to their own rhythm dictated by the set of the sail and the aspect of the boat to the breeze. When these telltales stream in unison your sails are working efficiently; when they move haphazardly you know it's time to change the trim. It's a delicate dance dictated by many forces and variables, one of the most important of which is the amount of stretch in the sail. If the fabric distorts, the shape of the sail changes and its efficiency is compromised. This balance between wind speed and sail shape is at the very core of sailmaking. It starts with a yarn, or more to the point, thousands of tiny yarns that form the basis of all sails. These fibers dictate the performance of the sail. So before we can explore the wonderful world of sailmaking, we first need to know and understand the different raw fibers that are used to make sails. It has been a fascinating evolution since cotton replaced flax, and polyester replaced cotton. Now the same fibers that are being used to build spacecraft are being used to make sails, bringing with them a wide variety of performance characteristics. Before you can decide which of them is right for your application, you need to know more about their relative strengths and weaknesses.

First though, some background. I grew up sailing on a small inland lake in South Africa in the 1960s, where we raced a local dinghy design called a Sprog. I remember my father, a good seat-of-the-pants sailor, always had excellent speed when sailing to windward, even though he was the only one in the fleet who still had sails made from Egyptian cotton by some long-forgotten sailmaker. Then again, it may have been that his sails had stretched to a point where the shape was perfect for the conditions. Whatever the case, like many old-time sailors, he was competitive until a new wonder fiber called polyester really took hold, at which point he had to relegate his cotton sails to the dump heap. The new polyester sails were able to maintain their shape through a variety of wind conditions to the point where he simply could no longer be competitive, and a whole new generation of sails was created. Since that time, increasingly sophisticated materials and methods have been both a bane and boon to sailors and the sailmaking industry. It's a bit like the computer business. As soon as you decide on a new computer somebody brings out an even newer one that is both cheaper and faster. Sailmaking is the same. As soon as you decide on new sails, along comes a new fabric or sailmaking technology that is better, or at least is perceived to be better. As a sailor and consumer it's important that you understand this evolution. While it's hard to predict the future, you can be better informed by understanding how we got to where we are today. Again, this comes from an understanding and knowledge of the very basics of sailmaking, and nothing is more basic than the fibers from which sails are created.

“The balance between wind speed and sail shape is at the very core of sailmaking.”

“ . . . new lands would not have been discovered, global commerce would have been severely hampered, and wars could have been lost.”

Before we look at the fibers that are currently being used to make sailcloth, let's run through some of the terminology that is used when discussing their properties. These terms are described in the glossary, but it is good to learn about them now to get a general overview of how they relate to fibers, and by extension, to finished fabric. They are all equally important to a good roll of sailcloth. The first three terms relate to a fiber or fabric's initial resistance to stretching and breaking. The second three terms relate to how a fiber or fabric holds up after use.

1. **Tensile strength** – The measure of the ability of a fiber, yarn, or fabric to withstand pulling stresses exerted upon it.
2. **Modulus** – The measure of a material's ability to resist stretching; usually its initial resistance to stretch.
3. **Tenacity** – The breaking strength of fibers.

To clarify these terms, tensile strength is a measure of a fabric's ability to withstand pulling stresses exerted upon it, while modulus measures a fabric's resistance to stretching. Tenacity is the point at which a fabric breaks. Obviously it's important when engineering fabric to bear in mind how much the fabric will change once a load comes on it, and when it will break.

4. **Creep** – The permanent elongation of a fabric under a continual load.
5. **Flex** – The ability of a fiber or fabric to retain its strength after being folded back and forth.
6. **UV resistance** – The ability of a fiber or fabric to resist the harmful degradation caused by constant exposure to sunlight.

A fabric engineer must understand what will happen to the fibers in sailcloth once they have been used. Creep, flex, and UV resistance are all properties to consider when choosing fibers because they will have an overall bearing on the product over time.

So let's start at the very beginning and work our way through each fiber with a look at their benefits and drawbacks. We will start at the beginning of modern fabrics. Palm fronds for sails is going back a bit too far, so we will begin with flax and cotton.

The Originals

Flax and Cotton

These fibers served the sailmaking industry longer than any modern fiber and were used by pleasure craft and warships alike from the earliest days of sailing ships. Without them new lands would not have been discovered, global commerce would have been severely hampered, and wars could have been lost. Flax, the first of the pair to be used by sailors, is made from the stems of the flax herb, a plant with narrow, pointed leaves and blue flowers whose name comes from the Old English word *fleax*. Cotton, of course, comes from the cotton plant and is refined by a process called ginning whereby the lint is separated from the seed. The lint is then spun into a thread that is finer than flax and can be woven tighter and with more

consistency. Today cotton and flax are used for sailmaking only when there is a need for authenticity, for example, aboard reconstructions of old square-riggers. Otherwise their attributes are heavily outweighed by modern synthetics.

Benchmark Fibers

Dacron/Polyester

Polyester, more commonly known by the name Dacron, is short for polyethelene terephthalate. Dacron is actually a trade name that was given to polyester by the Du Pont company, and thanks to some pretty effective marketing, it has become the most common name used to describe the fiber, and by extension, the fabric

From Flax to Cotton

It may seem foolish for any modern look at sails and sailmaking to be discussing cotton and flax sails. On the other hand it would also be foolish not to look back to the very beginnings of sailcloth, if only to illustrate how and why progress and change takes place, since it is sometimes for the most unusual reasons. In the early 1800s, for example, American warships had sails made from flax, at least until the Navy decided it needed to find something new. It did so not because it was concerned about the strength and usability of flax sails, but rather because the fabric was imported from Europe and the powers that be were afraid that if the supply of flax were ever cut off by the enemy the effectiveness of the American Navy would be compromised. There was at the time a small domestic sailcloth industry using cotton to build sails, but while it showed promise as a fiber for making fabric, there was still some debate among the ship captains of the day. Some felt that cotton absorbed too much water and was difficult to handle. Others said that flax was stronger and easier to use. Still others claimed that cotton sails did not stretch as much and the sails looked better than the flax ones. In the end it came down not to any decree from the Secretary of the Navy, but rather to a now historic boat race.

In 1851 the yacht America raced around the Isle of Wight off the south coast of England and handily beat the competition to win the Hundred Guineas Cup. That cup came to be known as the America's Cup, and while new fibers and fabric have been at the cutting edge of America's Cup competition since, few of them have had the impact that the sails on America had back then. While many observers were impressed by the schooner's hull shape, others noted that the cut of her sails was "as flat as a sheet of paper," which allowed the boat to be sailed closer to the wind, a huge advantage on any race course where the boats have to sail to windward. America's secret weapon then was not just below the waterline, but also in the cotton sails flying from the masts. Flax might be stronger in terms of breaking strength, but cotton did not stretch as much, and minimizing stretch became the name of the game. Soon the use of flax on warships was replaced by cotton. The rest, as they say, is history.

Naming Nylon

Nylon was actually named after the cities of New York and London, where Du Pont had offices at the time the fiber was being developed. Du Pont did not register nylon as a trademark, choosing instead to allow the word to enter the American vernacular as a synonym for stockings.

that results from weaving it. From a chemical standpoint, Dacron is a type of long organic molecule called a polymer manufactured from ethylene glycol – the same stuff used as automobile antifreeze – and terephthalic acid. In England polyester is called Terylene, and in other parts of the world it goes by various other names including Tetoron, Trevira and Diolen. The bottom line is that the name Dacron caught on, and for simplicity's sake in this book we will use only the terms Dacron or polyester to describe the fiber.

Polyester was initially developed in 1949 at the Du Pont plant in Seaford, Delaware, to create fabric for furniture upholstery and later for the much larger fashion industry. One of its initial attributes was that it did not mildew like cotton, and that alone set it apart. Soon word of its other qualities filtered down to the sailmaking industry: properties like high tensile strength and high modulus, both when the fabric was wet or dry, which meant that sails made from this material would not distort in high winds. There were other encouraging properties like high flex resistance, which meant that unlike many plastics it would not become weakened over time by flapping or folding; good UV resistance, which meant it would not become weak or brittle in the sun; and most importantly, good resistance to degradation by chemical bleaches and abrasion, which meant it could stand up to the rigors of the actual weaving process. Later it was discovered that polyester shrank when exposed to water and heat, which made it possible to create fabrics with an even tighter weave, one to which resins and finishes could then be added, thereby creating very stable sailcloth. Despite having pretty much the same basic strength and stretch characteristics as cotton, polyester's other attributes soon had it displacing earlier fibers. Thanks to this combination of properties, polyester has been a benchmark fiber in the sailmaking business for almost five decades.

These days Dacron is available in a number of different types that are differentiated by their tenacity. Type 52, for example, is the highest tenacity fabric and offers a premium balance of high strength, low stretch and maximum shrinkage when compared to other Dacron types. Type 56 Dacron has "regular tenacity" and offers most of the desirable attributes of Type 52 Dacron, but at a more reasonable price. There is also a fiber called 1W70 polyester, originally made by Allied Signal (now Honeywell), that has a higher tenacity than Type 52 Dacron, although it costs more. The two yarns are sometimes blended to gain performance without a dramatic increase in price.

Although in recent years Dacron has been replaced in many racing and megayacht applications by exotic high-tenacity and high-modulus fibers like Kevlar or Spectra, its proven durability still makes it a very popular yarn for cruising fabrics. It is also used for small racing boats and many one-design classes. In fact, in 2002 Dacron sails made up around 70 percent of the new sails being built around the world with laminates and molded sails making up the balance, and it's not likely that that number will decrease anytime soon. It really is a benchmark fabric that has stood the test of time. Part of Dacron's success can be attributed to its remarkable properties and affordability. But it also has an advantage in that woven Dacron can be used to make cross-cut sails, which are cheaper to build than radial sails

because there is less labor involved. This combination of a well-proven fabric and an efficient construction technique will undoubtedly result in Dacron remaining a major part of the sailmaking industry in the foreseeable future. In fact, it's likely some of those early polyester sails are still being used around the world. My Dad has retired from sailing. Otherwise his boat would be a good place to look.

Nylon

Nylon was the world's first true synthetic textile fiber. In fact, because it initially showed more promise as a fiber than Dacron, Du Pont focused its energies on developing nylon and actually let a British company by the name of ICI patent what was to become polyester. Later Du Pont had to purchase the U.S. rights back before it could further develop the fiber into what we now know as Dacron. In the meantime, nylon became a tremendously popular fiber both in the fashion industry and later for making parachutes during the Second World War. Eventually its strength and durability were recognised by the sailmaking industry and the fiber was used to make light fabric for spinnakers.

Nylon is particularly suitable for this use because it has some give, and for spinnakers strength for weight is more important than stretch resistance. Spinnakers are used when sailing downwind when the loads on the sail are greatly reduced. Nylon has a high strength-to-weight ratio and fortunately can quickly recover from being overstretched. In fact, the elasticity of nylon is good for spinnakers since these sails often collapse and refill with a high shock load being placed on the fabric, so that a little give helps keep the fabric and seams intact. Another attribute of nylon is that it can be easily dyed, with the result that you often see colorful spinnakers, while Dacron working sails usually only come in white. There are, however, some drawbacks. For example, nylon is more susceptible to UV and chemical degradation than polyester and should never be washed with chlorine bleach or rinsed in a swimming pool.

Polyethelenes

Pentex

The first real advance on basic polyester came with the development of a fiber called polyethylene naphthalate, or Pentex for short. This modified polyester is made by Honeywell Performance Fibers under the trade name of PEN and is, in fact, a super-Dacron combining all the great qualities of Dacron without the one major drawback – stretch. Pentex was developed for the tire and mechanical rubber markets and has several features that make it well suited for sailcloth applications, including the fact that it is rugged and has two and a half times the modulus, or stretch resistance, of regular Dacron. This translates into two and a half times less stretch for sails of equal weight.

One drawback to Pentex is that it only shrinks about 5 percent for its length when exposed to water compared to Dacron, which shrinks from 15 to as much as 20 percent of its length. As a result, when making up a Pentex fabric the weaves are not as tight as those made from Dacron since shrinking the woven fabric is key to creating a tight, stable weave. Unfortunately for the sailmaking industry, Pentex

“One drawback to Pentex is that it only shrinks about 5 percent for its length when exposed to water compared to Dacron, which shrinks from 15 to as much as 20 percent of its length. As a result, when making up a Pentex fabric the weaves are not as tight as those made from Dacron . . .”

was developed specifically not to shrink. For a while, fabric makers tried adding large amounts of resin to the finished fabric to help stabilize it. This, however, caused problems of its own, and now Pentex is used almost exclusively in laminated sailcloth, i.e., cloth in which fibers are glued to sheets of a substrate material like Mylar instead of being woven into cloth by a conventional loom. The finished fabric benefits from the strength and stretch resistance of the fiber, while the substrate offers overall stability. Today, Pentex fabrics provide a lower-cost option for racing sailors looking for higher performance without the huge increase in expense that comes from using other cutting-edge materials. In fact, the popularity of Pentex is largely driven by the racing rules in some fleets that outlaw more exotic fibers in an effort to keep the cost of remaining competitive down to a reasonable level.

An additional benefit to Pentex is that it retains as much as two to five times its breaking strength compared to standard polyester after being exposed to UV radiation (according to Honeywell Performance Fibers, which conducted its own UV tests on Pentex using a xenon arc to simulate the sun's ultraviolet rays). This improved UV resistance is a significant benefit as it more than doubles the life of sails used in tropical waters. In all, Pentex offers real value as a performance cruising fabric, and is a good alternative to Dacron for a racing fabric.

Spectra

Spectra is also made by Honeywell Performance Fibers and is a "highly processed ultra-high molecular weight polyethylene" or UHMWPE, according to the literature put out by Honeywell. This outstanding fiber has been used to build sails for megayachts and for numerous racing sailboats competing in offshore

My own boat, Great Circle, had an inventory of Spectra sails that served me well for many years and many offshore miles.



races like the Volvo Ocean Race, the Vendée Globe, and the Around Alone. My Open 50 racing boat *Great Circle* had sails made from Spectra, and they always performed beautifully.

Spectra's initial modulus is second only to carbon fiber, a remarkable attribute for a fiber that, like Dacron, also has terrific flex properties and good UV resistance. The problem with Spectra is that under continuous load it starts to creep, or permanently elongate, with the result that the fiber is not used in ultra-high-performance racing sails like those used in the America's Cup in which precise shape control is crucial. On the other hand, aboard large cruising boats where strength, UV resistance, light weight, and durability are paramount, Spectra yarns are often ideal. This is especially true when used in a woven format since wovens are extremely durable and offer great chafe protection. One additional drawback to Spectra is that it has a slippery feel and does not bond well with adhesives, making it very difficult to laminate. As a result, fabric makers always try to laminate film to film between the Spectra scrim when making the cloth.

The most commonly used Spectra fiber is called Spectra 1000, but Honeywell Performance Fibers also makes an even higher modulus Spectra called Spectra 2000, which is usually used to make Cuben Fiber sailcloth, although it can also be used for regular laminated Spectra fabric. Spectra's other, more popular application is for making bullet-proof vests and reinforced cockpit doors on airplanes. As a result, when there is a war or general unrest in the world, the price of Spectra skyrockets as demand exceeds supply.

Dyneema and Certran

Dyneema and Certran are very similar to Spectra, but Dyneema is manufactured by a Dutch company called DSM and Certran is made by a company called Celanese. Dyneema is often used by European sailmakers and is growing in popularity in the United States, since among other things it is available in a wider variety of yarn sizes than Spectra allowing for the creation of more fabric styles. Certran has a modulus somewhere between Spectra 1000 and Spectra 2000.

Aramids

Kevlar

Kevlar is probably the most recognised fabric for sails other than Dacron. This pale gold sailcloth has set the world of competitive yacht racing on fire and also done its fair share to contribute to the expense and frustration of being a sailboat owner, especially at the top end of the sport. Basically, to be competitive at the grand prix level you need Kevlar sails. But while Kevlar's benefits include low stretch and a high strength-to-weight ratio, its drawbacks include a lack of durability and short competitive life. Unfortunately, even the very best Kevlar sails won't last very long. It's a delicate balance between performance gain and prohibitive expense.

Kevlar is a fiber that was created and introduced by Du Pont in 1971 when two research scientists by the names of Stephanie Kwolek and Herbert Blades set out to create an entirely new fiber. Their success has had a lasting impact on not only the sailmaking industry, but the world as a whole. It is stronger



Some fabrics are made from a blend of fibers such as Kevlar and carbon in order to maximize the benefits of each.

than steel for its weight and has a modulus five times greater than polyester. When Kevlar was first introduced to the sailmaking industry there were two types: Kevlar 29 and Kevlar 49. Each had properties that were a trade-off against the other. Specifically, Kevlar 49 had a 50-percent higher modulus than Kevlar 29, but what it gained in stretch resistance it gave up in flexibility. Again, because sails flog and flap in the wind, the ability of a fiber to handle flex is very important. Another important drawback with Kevlar is that it has terrible UV properties. In fact, Kevlar loses its strength roughly twice as quickly as polyester, and as soon as it is exposed to sunlight it loses its attractive gold color and turns a dull brown. As a result, the two main ingredients of a summer's day on the water: wind (which causes flogging) and sunshine (which causes UV degradation), are the two worst enemies of this strong but delicate fiber. Fabric makers have since been able to compensate for some of Kevlar's weaknesses by encapsulating the yarns with rugged taffetas that both protect them from the harmful rays of the sun and dampen the bending moment as the sail flaps in the wind.

Since the debut of Kevlar 29 and Kevlar 49, Du Pont has introduced a number of other Kevlar styles including Kevlar 129, Kevlar 149 and Kevlar 159. While these fibers have terrific stretch resistance, this increase in modulus goes hand-in-hand with even lower flex strength, so that most of these fibers have not been useful for making sails. Basically, it's interesting to know that these kinds of fibers exist, but unless sailmakers and fabric makers can figure out how to overcome their weaknesses they might never enter the sailmaking realm.

Another recent Kevlar style introduced by Du Pont is called Kevlar Edge. This new Kevlar fiber has 25-percent higher strength than Kevlar 49, better modulus, and it continues to hold up well after repeated flexing. It also resists breaking, and because of these attributes it is becoming more widely used in sailmaking.

In the end, minimal flogging, careful handling when bagging the sails, and protection from UV exposure can greatly add to the life of Kevlar sail. Despite its cost and weaknesses, it looks as if Kevlar is here to stay as one of the leading performance fibers.

Technora

Technora is produced in Japan by a company called Teijin. This distinctive black yarn is similar in modulus to Kevlar 29 with a slightly better flex capacity. The raw fiber is in fact gold, but fabric makers dye the yarns black to improve the fiber's low UV tolerance. While Technora sails were popular for a while, the fiber

Thank Goodness for Ted Hood

In the early 1980s I was fortunate enough to be part of the crew of the maxi-boat Nirvana. At the time the boat was a cutting-edge design that held true to my theory that beautiful boats also sail fast. David Pedrick drew the lines, and the boat was a pleasure to behold. It was also fast, despite the built-in dishwasher, washer and dryer, and full-size bathtub in the master stateroom. We raced the boat all over the world in places like Sardinia, Mallorca, Scandinavia, Malta, the Caribbean, and New England.

The sail program was an important part of the overall success of the project, and Marvin Green, the yacht's owner, spent wisely on new sails. He knew that the latest technology would give him an edge and always listened to new ideas. At that time laminated sailcloth was just gaining a foothold, and we made a new Kevlar mainsail for the boat. In the loft the sail looked beautiful and we shipped it over to Sardinia for the Maxi-Boat World Championships. I was racing on board as mainsail trimmer, and for the regatta we were fortunate enough to have Ted Hood on board. Ted had long since sold Hood Sails, but he was still active in helping promote the company, and if his schedule allowed it, he would show up for key regattas.

We had a practice sail the day before the first race and everything seemed fine. The morning of the first race dawned sparkling bright, and we left the dock early to get ready for the race. On the way out to the start line we hoisted the new mainsail and motored around in a light, but building breeze. Suddenly, on a routine jibe, the mainsail crossed the boat, the boom snapped up against the mainsheet and the golden Kevlar mainsail ripped from luff to leech. I was never so happy to have Ted Hood around. Marvin and the crew all looked at me, and I just shrugged and looked at Ted. It seems we had underestimated the poor flexibility of Kevlar yarns. When building the sail the edges of the mainsail had been tabled, or folded over and tucked under a Dacron leech tape. The sail had then been folded and bricked for shipping so that the folds were at right-angles to the tabling with the result that where they met, the fabric formed a sharp point. When we removed the leech tape later that evening, we found small inch-long tears at each fold. Luckily, we were early enough for the start that we were able to send for the spare mainsail, and with it we went on to win the regatta.

is now used mostly as part of a composite laminate with the Technora fibers being used on the diagonal for bias support. Other fibers with improved performance and comparative cost have replaced Technora.

Twaron

Twaron is also produced by Teijin and is chemically and physically similar to Kevlar. Like Kevlar, the fiber is a bright gold color. High-modulus Twaron (HMT) has similar stretch properties to Kevlar 49, and it has better tensile strength and better UV resistance.

Vectran for the Defense Industry

Like many of these exotic yarns Vectran was developed for the defense industry. The Navy needed a fiber that would not stretch over time so that it could tow listening devices behind submarines. Specifically, the listening device had to remain a certain, precise distance behind the sub to tune out the noise of the submarine's engine. The fiber also had to withstand being dragged through the water for weeks at a time. The result was Vectran, and the sailing world became a lucky benefactor of this technology.

Liquid Crystal Polymers

Vectran

Vectran is one of the newer high-tech fibers introduced into sailmaking and because of its strong properties it has gained a foothold in the industry. According to the literature put out by Celanese, the manufacturer of Vectran, it is “a high performance thermoplastic multifilament yarn spun from Vectra, a liquid crystal polymer, and is the only commercially available melt spun LCP fiber in the world.” While this sounds impressive, and it surely is, the physical properties of Vectran are even more remarkable. Pound for pound, Vectran is five times stronger than steel and 10 times stronger than aluminium. It has a modulus similar to Kevlar 29 and does not lose any of its strength after being flexed. It has zero creep, high chemical and abrasion resistance, and high tensile strength. Unfortunately, it is also sensitive to light, and unless the Vectran yarns are protected from the sun's UV rays, the fiber becomes weak and breaks. There are two more positive points about Vectran. First, it repels water and therefore does not foster mildew. Second, because the yarns are produced as flat ribbons, they bond extremely well to films and taffetas.

Despite all of these terrific attributes, Vectran has not been rewarded with the place in the sailmaking industry that it deserves. Some of this has to do with politics. Doyle Sailmakers was the first to recognise the positive points of the yarn and actively marketed the fabric using it to make sails for the restored J-Boat *Velsheda*. Clearly the fabric was excellent, but maybe because Doyle was the first to run with it there was a backlash on the part of some of the other sailmakers. It's true the Vectran does have weak UV properties, but as you will learn in the next chapter, there are ways to engineer a sail to deal with that drawback. Perhaps in the final analysis it's because of the color. Racing sails are gold, and cruising sails are white. Vectran is a product for the cruising market and it's not white, it's a pale gold. It may be as simple as that.

PBO

PBO is currently at the top of the performance pyramid when measured against other fibers, and it offers an option for out-and-out grand prix racers who want to save weight and increase the overall performance of their sails. It was initially developed by Dow Chemical, but because Dow is not in the business of making fibers, the technology was sold to the Japanese company Toyobo, which now produces the fibers under the trade name Zylon. PBO is a liquid crystal polymer that weight-for-weight has better strength and stretch characteristics than any other currently available fiber, including the aramids. Naturally gold, PBO's other attributes are reasonable flex, high cut and abrasion resistance, high chemical resistance, high tensile strength, and low creep. These benefits, however, come at a cost. PBO is extremely light-sensitive and degrades not only from sunlight, but from any kind of visible light. Unless the fiber is sandwiched between UV-enhanced films, it has a very short life. As a result, although PBO is an excellent fiber for making sails, its cost and short life expectancy often outweigh its good qualities. In fact, at the time of writing sailmakers were experiencing a backlash



The One World America's Cup entry used a lot of carbon in their inventory of North 3DL sails.

from their customers because of the extremely short life of PBO, and fabric makers had stopped using PBO alone for sails. Instead, they were trying to minimize PBO's shortcomings by blending it with other yarns, creating fabrics from PBO and Kevlar 49, or PBO and high-modulus Twaron. The result is fabric that is lighter and stronger than one made from an aramid only, but one that lasts longer than a pure PBO sail.

Carbon Fiber

Carbon fiber is a high-modulus synthetic fiber made from an acrylic containing carbon, hydrogen, and nitrogen atoms, and while it has been used successfully for many years to build sailboats, it has only recently been introduced into mainstream sailmaking applications. Up until this point the fiber has been both too brittle and too expensive for general use. It is, however, used extensively in the high-end racing arena like the America's Cup.

As part of the process of making the fiber, the carbon is heated in three successive stages until all but the carbon atoms are eliminated. The result is an exceptionally low stretch-for-weight fiber that is usually used as part of a blend when making fabric. When used in sails the carbon fibers are combined with other more durable fibers like Kevlar, Spectra, or Vectran in much the same way that PBO is used. The result is a measure of durability, without a sacrifice in modulus. In the ever-increasing race for a performance edge, it's likely that we will be seeing a lot more of carbon fiber in future applications.

A Final Word on Yarns

There are a number of fabric manufacturers in the United States and Europe that all make excellent fabrics, but I have specifically shied away from naming certain products for certain applications. Often a number of fabrics meet the same needs, and choosing fabrics becomes a matter of personal preference or brand loyalty

Bolts of carbon fabric awaiting shipment at the Dimension Polyant facility in Connecticut.



and cost. I have tried to provide general guidelines to steer you in the right direction, but ultimately you will need to discuss with your sailmaker the specific benefits and drawbacks of each fabric style. Among other things, the weights, styles, and performance characteristics of the various fabrics are constantly changing.

Fabric makers are not the type to let the bad properties of a particular yarn stand in the way of progress, and they are constantly working to combine fibers. These hybrid fabrics exploit the strengths of individual yarns while minimizing their weaknesses. In the next chapter we will look at how these miracles of science are used to make sailcloth. It has been an evolutionary process that over time has led to sails that are lighter, stronger, and more cost effective. More importantly, it has led to sails that are true engineering wonders.

“Fabric makers are not the type to let the bad properties of a particular yarn stand in the way of progress, and they are constantly working to combine fibers to exploit the strengths of the individual yarns while minimizing their weaknesses.”

Chapter 3

FROM THREAD TO FINISHED FABRIC

How Sailcloth is Made

So many fiber choices leave fabric engineers with the interesting and complex task of deciding how to use them. Indeed, the possibilities are endless. Not only can engineers group different amounts of the same fiber in a fabric, they can group different amounts of different fibers in the same fabric, orient them in any number of ways and then adhere them to a substrate that is baked in an oven, all in an effort to end up with a superior sailcloth. It's a sort of one-plus-one-equals-five scenario. Not surprisingly, the process can become extremely complicated, and in fact this is one of those areas in which sailmaking departs from the fixed limitations of science and delves into the area of art. It's why the subject is so fascinating. In this chapter we will look at how the fibers discussed in Chapter 2 are used to their best advantage and how some fabrics are designed for certain specific applications. In a later chapter we will look at new technologies like molded sails and tape-reinforced sails, but this chapter is specifically about creating fabrics from which panels are cut and sails are made. By understanding these different techniques you will begin to understand which fibers, and by extension, which fabrics best suit your needs.

This chapter is divided into three sections:

1. **Woven fabrics** – those fabrics that are manufactured on a loom in a conventional manner.
2. **Laminated fabrics** – fabrics that comprise two or more layers glued together; these fabrics can have a woven substrate, but they do not rely solely on the woven part for stability and stretch-resistance.
3. **Cuben Fiber** – a whole new way of creating fabric in which layers of film and fiber are subjected to heat and pressure in an autoclave.

These are three quite different ways of creating fabric, but the end goal is the same: to create sailcloth that is light, cost effective, and stretch-resistant, both along its principal axes and on the bias. Like the sailmaking business in general there are two main ingredients that account for the price of fabric: labor and raw materials. The least labor-intensive way of making sailcloth is to weave and finish it, followed by lamination, with Cuben Fiber being the most labor intensive. In terms of the base fibers, polyester, from which sails are woven, is much cheaper than Spectra or one of the other “exotics.” Therefore a woven Dacron sail will be the least expensive. Your aim when thinking about new sails is to choose a fabric that suits your needs perfectly. You don't want to pay extra for something you don't need, but by the same token, you don't want to choose a fabric that is not up to the task for the sake of saving a few dollars. By reading and understanding the different manufacturing techniques you will be much better informed when it comes time to make your own purchase.

“... the end goal is the same: to create sailcloth that is light, cost effective, and stretch-resistant, both along its principal axes and on the bias.”

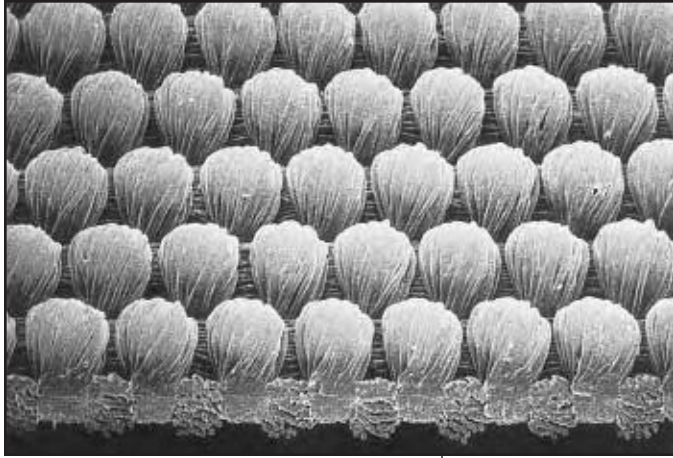

A view of North's NorDac fabric magnified to show the tightness of the weave.

Woven Fabrics

With the perspective of time it's easy to look to the past and think about how simple it must have been to design sails back in the good old days, even at the grand prix level. There was only one fiber to think about – polyester – and only one way to use that fiber to make sailcloth – by weaving. We forget, however, how hard it was to engineer a sail within even these seemingly limited parameters and have it perform efficiently. Weaving, for example, was an inexact process in the past that allowed many variables, so that when combined with a restricted panel layout, the task of engineering a sail to hold its shape was daunting. Therefore, to fully understand the difficulties faced by sailmakers, both yesterday and today, we need to look at the weaving process to understand how Dacron sailcloth is manufactured, the problems manufacturers encounter and how they strive to overcome them. We also need to know some of the terminology used to describe sailcloth and its various components since this goes to the very heart of how woven sailcloth is manufactured.

Understand the difficulties faced by sailmakers, both yesterday and today, we need to look at the weaving process to understand how Dacron sailcloth is manufactured, the problems manufacturers encounter and how they strive to overcome them. We also need to know some of the terminology used to describe sailcloth and its various components since this goes to the very heart of how woven sailcloth is manufactured.

WARP AND FILL

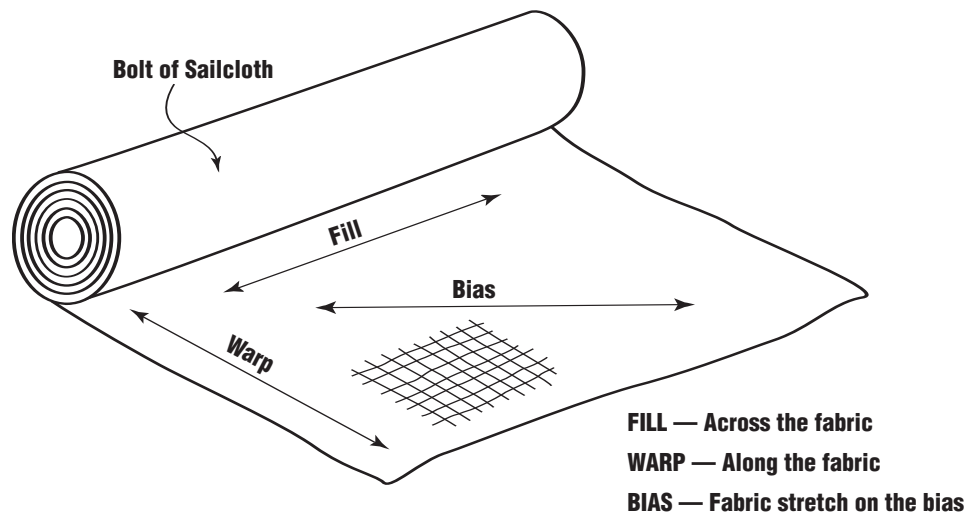

Figure 3.1

The warp refers to the yarns running the length of the fabric while the fill refers to the yarns running across the fabric.

Warp and Fill

The warp refers to the yarns running the length of the fabric while the fill refers to the yarns running across the fabric (Figure 3.1). Another name for the fill is weft, but most sailmakers and sailcloth manufacturers prefer to use the more modern name. A fabric engineer can design a fabric to be warp-orientated by using heavier yarns running the length of the fabric or he can design a fabric to be fill-orientated by using heavier yarns along its width. Balanced fabrics, as their name implies, are equally balanced between the warp and fill so the fabric will exhibit equal strength in both directions (Figure 3.2).

Denier Per Inch

Dacron at its most basic is a collection of tiny filaments or single fibers of polyester that, when twisted together with other fibers, become a yarn. The fabric engineer actually gets involved in the process as soon as a single filament gets twisted around another. The number of twists per inch and the number and thickness of each filament has an effect on the bulk and strength of each yarn, and by extension, the characteristics of the woven fabric. In order to have a basis from which to work, fabric makers have a system for coding filament yarns and fibers based on something called a denier, a term that you will come into contact with during your search for fabric for your new sail. Specifically, a denier is the weight in grams of 9,000 meters of a given fiber. The lower the number, the finer the fiber. When talking about a woven fabric, the relative weight and strength of the fabric is expressed in terms of denier per inch, or DPI as it's known in the trade. This number is critical to a sailcloth's performance. For example Challenge Sailcloth, a fabric manufacturer that specialises in woven Dacron fabrics, makes a 7.62-ounce fabric that has a DPI of 220 in the warp and a DPI of 570 in the fill. The company also makes a 9.62-ounce fabric that has a DPI in the warp of 220 and a DPI in the fill of 880. These numbers tell the sailmaker how strong the fabric will be and how best to use it. By engineering fabric strength in a certain direction, as in the 220 x 880 cloth, the fabric designer is sending a message to the sail designer that this fabric has a lot more strength in the fill direction and therefore should be used accordingly. The sail designer will take advantage of the fabric's strength and orient the cloth so that the stronger fibers will bear the bulk of the loads generated by the wind. Both of these fabrics are fill-orientated and should be used for sails where the loads run principally up the leech of the sail. To give you some perspective on how these abstract figures relate to the real world, the 7.62-ounce fabric would be good for a mainsail on a 30-foot daysailer, and the 9.62-ounce fabric would be good for a high-aspect blade jib on a 40-foot racer/cruiser.

The Loom

Armed with these basics we can now begin to look at the mechanics and challenges of producing high-quality sailcloth, both yesterday and today. There is no need to go all the way back to flax and cotton. Those sails simply projected an area to the wind and the boats that used them were blown along in a fairly inefficient manner. It is instructive, however, to look at the challenges sailmakers faced when they first began to work with synthetics. For it was at this time, as sail designers came to have a better understanding of aerodynamics and the way in which certain sail shapes allowed sailboats to sail into the wind, that the need for stable fabrics and stable panel layouts became increasingly necessary; stable in this context meaning sails that did not stretch out of their intended aerodynamic shapes.

Figure 3.2

Balanced fabrics, as their name implies, are equally balanced between the warp and fill so the fabric will exhibit equal strength in both directions.

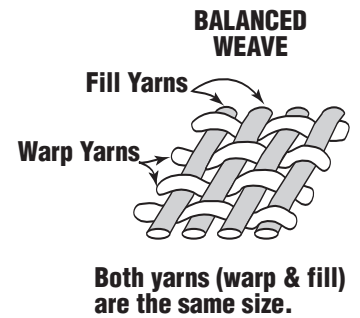
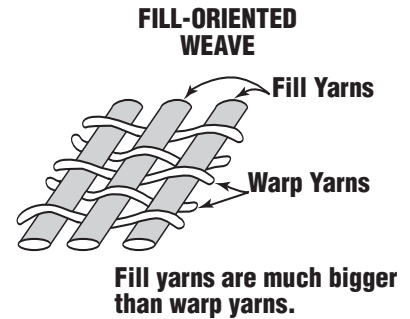

Modern looms are complex pieces of equipment that can handle thousands of fine yarns working at high speed without anything breaking.

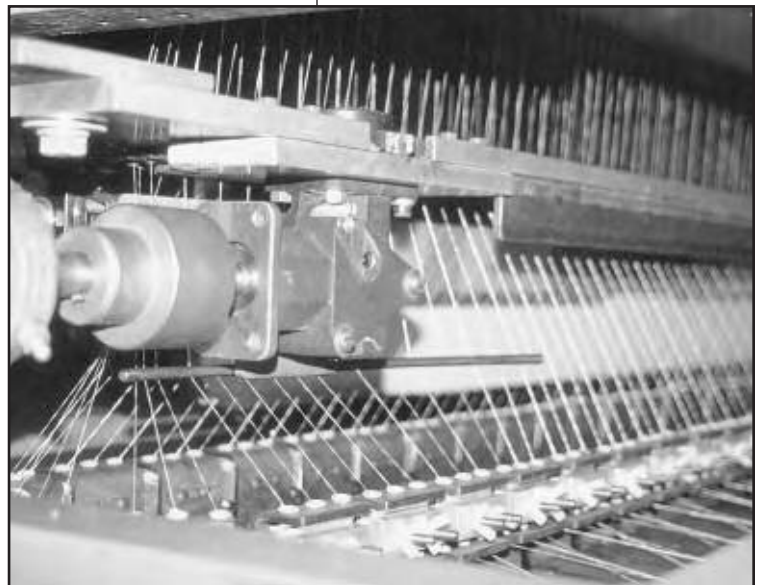

Racks of fabric packaged and ready for shipping to sailmakers sit in the warehouse at Dimension Fabrics in Connecticut.



The art of weaving goes back centuries, and while modern looms for producing sailcloth are more sophisticated than those used either in the past or for producing household fabrics, the basic process is the same. First, the warp yarns are stretched horizontally side by side and fed through the loom where they are held under tension to get the most benefit from each individual thread. During the actual weaving process, each alternate yarn is pulled vertically apart while a shuttle containing the fill yarns is sent back and forth across the fabric at high speed. After each pass, the fill yarn is slammed into place by an appropriately named “beater” and the warp yarns are reversed so that the yarns that were on top become the yarns on the bottom and the yarns that were on the bottom end up on top. The shuttle then races back across, putting in another fill yarn, which is once again slammed into place. This process of alternating the warp yarns, shooting the fill shuttle and slamming the beater takes place at lightning-fast speed, and with each new fill thread, the length of woven sailcloth increases.

Not surprisingly, the width of a panel of sailcloth is dictated by the width of the loom and most modern sailcloth looms are 60 inches wide resulting in a fabric that is 54 inches wide once it is finished and the edges trimmed. The length of the fabric is only limited by the amount of yarn each bobbin can hold, and finished rolls of sailcloth are usually hundreds of yards long. Setting up the loom is extremely time consuming so the fabric makers strive to produce long runs of sailcloth each time they make a particular style of fabric. Obviously, the way in which the loom is prepared goes a long way toward determining what the finished product will be like, so the manufacturer needs to know exactly what he wants from the very beginning of the process.

If, for example, he is planning on making a heavy Dacron to be used on bigger boats and in stronger winds, he will load his loom accordingly. He might use a 300 DPI yarn for the warp and a 1,000 DPI yarn for the fill so that the finished product, weighing 10.0 ounces, will be good for a working genoa on a Beneteau 456 or a mainsail on a Cabo Rico 38. If on the other hand, he wants to build a light Dacron fabric for a one-design dinghy fleet, he will load

the loom with 150 DPI yarns in the warp and 250 DPI yarns in the fill for a fabric that weighs 3.9 ounces and can be used to make a mainsail for a smaller boat like a Laser.

During the actual weaving the conditions in the mill need to be carefully regulated since both heat and humidity have an effect on the process. Specifically, the temperature must not rise above 70 degrees Fahrenheit, and the humidity must remain below 53 percent. Otherwise the Dacron yarns will shrink prematurely or unevenly, compromising the density and strength of the finished product. With a strictly controlled environment, high-tech custom looms, and carefully engineered yarns, the initial stage of Dacron sailcloth is complete.

Bias Stretch

While the bobbins holding the warp and the shuttle holding the fill are important, it's actually the beater that plays the most important role in weaving sailcloth. As noted above, the finished fabric has strength both along and across the cloth, since pulling in those directions means pulling along the length of the yarns. But it is weak along the diagonal since forces working in this direction are pulling at an angle to the yarns and can distort the weave. To minimize this "bias stretch" as it's called, the weave has to be tight, and the harder the beater slams into each fill yarn, the tighter the weave.

In fact, much of the weaving process is designed to eliminate, or at least minimize the bias stretch of the finished fabric, so let's study this aspect of fabric design in more detail. By way of illustration, take any household fabric and look closely at the warp and fill fibers. Assuming that it's a conventionally woven fabric, try stretching it by pulling in either the warp direction or the fill direction. Chances are you will meet with some pretty substantial resistance as you tug directly against the dozens of tiny yarns. Now take that same fabric and pull it from corner to corner, in other words on the bias (Figure 3.3). Immediately, the fabric will stretch and distort. Now imagine what can happen to sail shape in a

Figure 3.3

Try stretching any woven fabric by pulling in either the warp or fill direction. You will meet with some pretty substantial resistance as you tug directly against the dozens of tiny yarns. Now take that same fabric and pull it from corner to corner, in other words on the bias. Immediately, the fabric will stretch and distort.

BIAS STRETCH

Loads across and along the fabric pull directly on the yarns.

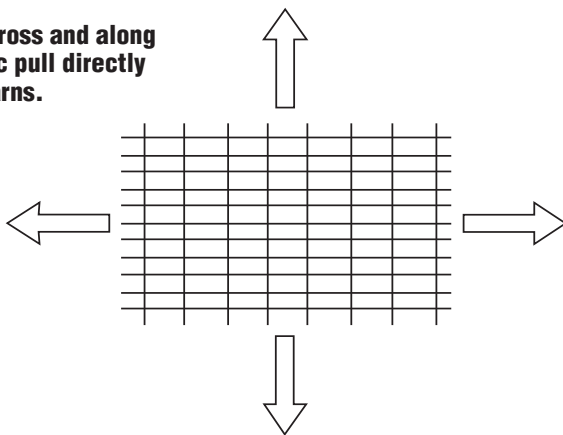

When pulled on a bias, the fabric elongates.

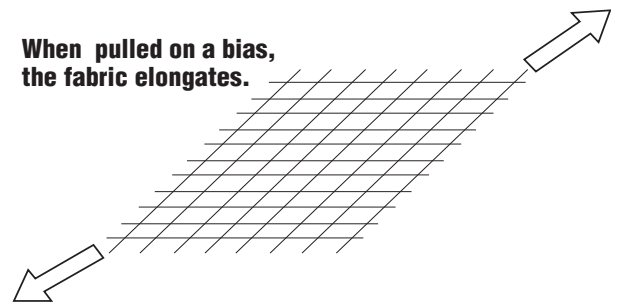
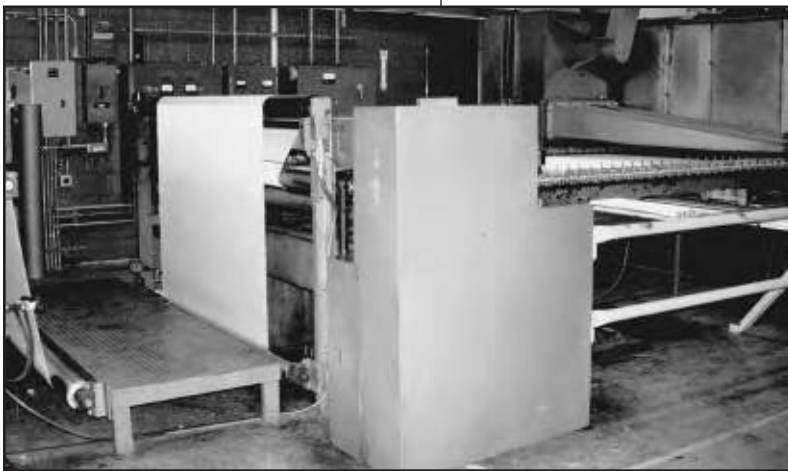

Figure 3.4

The fill yarns are shot across the fabric by the shuttle, therefore, they tend to be laid down absolutely straight. But since the warp yarns go over and under the fill there is a lot of room for elongation once a load is exerted on them.

As part of the manufacturing process, woven Dacron is passed through a huge heater where temperatures of around 400 degrees Fahrenheit shrink the yarns in order to create a tighter weave.



heavy breeze when the load no longer travels along the engineered load paths, but rather comes onto the bias. The sail will stretch and distort and the carefully crafted shape will no longer resemble anything the sail designer had in mind.

Crimp

This problem of sails stretching is further exacerbated by another inherent aspect of woven fabrics known as crimp, a word that comes from the Dutch word meaning “to shrivel.” Because the fill yarns are shot across the fabric by the shuttle, they tend to be laid down absolutely straight. But since the warp yarns go over and under the fill, the angle at which they are forced into place by the beater means that there is a lot of room for elongation once a load is exerted on them and the yarns try to straighten out (Figure 3.4). Like bias, this phenomenon is impossible to completely avoid but can be minimized through careful processing of the cloth after its initial weaving. In fact, at this early stage in its production the fabric, which is known as Greige cloth, a term that comes from an old French word meaning raw silk, bears little resemblance to the finished product that most sailors are familiar with. Specifically, it is very soft, ragged along the edges, and somewhat dirty from the weaving process. In the United States the refined French word has been turned into a somewhat more descriptive one, namely “gray” cloth. There are still a number of additional stages to complete before the finished fabric is ready for the sailmaker. These stages are all aimed at minimizing distortion.

Heat Setting and Fillers

The most important of these steps is heat setting, a carefully regulated process that takes advantage of the previously mentioned fact that Dacron shrinks when exposed to high temperatures. In fact, one of the reasons Dacron became such a popular sailcloth fiber in the first place is that, in addition to being easily woven, this shrinkage results in a fabric that, despite having a bias, is fairly stable when used for making sails. Immediately before this all-important step, the fabric is scoured with hot water and detergent to

remove dirt and other impurities like oil drips. The hot water and detergent also remove a kind of a glaze called “sizing” that is added to the yarns to prevent them from breaking during weaving. The sizing gives the yarns extra strength to handle getting yanked and tugged during the weaving process. The fabric is then dried and either passed through an oven or over heated rollers where each strand of Dacron is exposed to a temperature of around 400 degrees Fahrenheit for approximately one minute. At this point a chemical reaction locks the fibers together, shrinking the cloth by as much as 15 to 20 percent, most of it in the warp direction because of the crimp.



Dacron fabric is passed through a trough of melamine resin to fill the gaps between the yarns and prevent bias stretch.

As heat setting became more of a science, fabric makers experimented with varying temperatures, and a series of progressively hotter stages allowed some control over the integrity of the finished product. Early Dacron fabrics were manufactured using this process alone, and the resulting sails had good, if not perfect shape-holding characteristics. They also had a nice soft feel to them, which was important to many sailors since it allowed them to be comfortably handled, and the sails could be folded into small packages and stowed in bags that did not take up much room on board. In the years that followed, fabric engineers found that they could further reduce crimp and bias stretch by adding chemical fillers that would further stabilize the fabric, however, because these fillers took away the nice soft “hand” and replaced it with a stiff, hard-to-handle finish, some say they gave the fabric a performance edge not worth the ease-of-handling trade-off. The sail-handling versus performance debate continues to this day, and has become more pronounced with the advent of new yarns and fabric technologies.

Fillers

Once the fabric has been heat set, the next step is to add fillers. This involves dipping the newly woven cloth into a bath of melamine resin – the same resin that is used to build fiberglass boats – so that when the treated fabric is heated, the yarns and solution, which are chemically similar, become one as the chemical properties in both align themselves to form a durable, relatively low-stretch fabric. By using different varieties and concentrations of melamine, a fabric maker can produce a number of different kinds of sailcloths all based on a single weave. These fabrics vary radically in terms of feel and stretch resistance. Think of the hardened melamine filling the gaps between yarns so that when the fabric attempts to stretch on the bias, the filler braces the square configuration of the weave making sure that it does not elongate into a diamond, thereby resisting bias stretch.

Finishing

In addition to adding melamine filler, fabric engineers also learned to further stabilize and refine the fabric by passing it through additional baths of other resins in what is called “finishing.” Different resins are used for different fabrics. For example an acrylic finish is used for Dacron and a polyurethane fin-

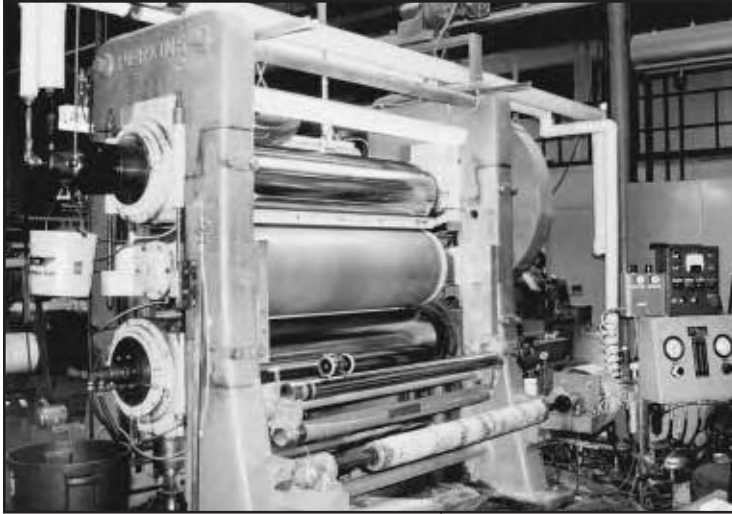

At the end of the process giant rollers apply tremendous pressure on the woven fabric to flatten and further tighten the weave.

ish for nylon. As the fabric comes out of the bath it is squeezed between a roller and a sharp steel blade that both forces the resin into any gaps or indents in the fabric and removes the excess. This part of the process is known as “yarn-tempering,” and the final result is a smooth finish that ensures the fabric is non-porous and even more stable.

Calendering

Finally, after the fillers and resins have been added, the bolts of fabric are passed between two giant heated rollers that apply tremendous pressure on the fabric, flattening and further tightening the weave in a process called calendering. The pressure exerted can

be as much as 150 tons, and some fabrics are passed through the calender a number of times, until the fabric takes on a high sheen. At this point the woven Dacron fabric is as nonporous and low-stretch as it’s ever going to be, so there’s nothing left to do but trim the edges with a hot-knife and roll the finished fabric into bolts for shipping.

Stable Fabrics at Last

With this kind of stable sail fabric on the market, the art of sailmaking had at last reached the point where a designed sail shape was not easily distorted, and sail designers could start to experiment with different fabric weights and strengths in an effort to refine their work. Design development is heavily reliant



In an effort to improve Dacron, Hood Sailmakers began manufacturing narrow panel fabric seen here in this classic ketch.

upon hard data, which in turn can only be created from fabrics that are predictable, stable, and uniform. Even the earliest Dacron fabrics were better than their predecessors and were used successfully on both cruising boats and high-performance racing boats like those in such demanding events as the America's Cup and Whitbread Round the World Race. They were tried and tested under some of the harshest conditions, and to this day many sailors swear by their basic woven Dacron sails. There is something about a product that has stood the test of time that instills confidence. On the other hand, while the status quo might be good for most sailors, a few always demand and expect more, and since the early days of Dacron a lot has happened.

An Effort to Improve Dacron

Despite the fabric engineers' best intentions, for example, after a while all those fillers and finishes added to woven sailcloth begin to break down, and what starts off as crisp, low-stretch fabric becomes a softer, more easily manipulated sailcloth that begins to stretch and distort the sail shape. Therefore alternative means of creating a tight weave were sought.

In the late '70s and early '80s Hood Sails believed it had solved the problem by producing its fabric in 24-inch-wide panels, rather than the 54-inch panels used by other fabric makers. With less distance upon which to exert pressure, it was reasoned, the beater would be able to create a tighter weave. There was probably some truth to this line of thought, and narrow-panel Hood sails were seen all over the world. In time, however, they were replaced by newer technologies, since among other things the added cost of sewing twice as many seams pushed the price up for very little commensurate gain.

Sailmakers also discovered that if the warp yarns were made much heavier than the fill yarns and then were pulled through the loom with a lot of tension the fill yarns would actually bend, leaving the warp yarns with much less crimp. This was especially helpful in terms of radial-panelled sails, i.e., sails made of panels radiating from the corners of the sail as opposed to the parallel panels in a cross-cut sail. Unfortunately, you could not have a fabric that was completely dominated by the warp to the exclusion of the fill since the result would be a lot of bias stretch. In order to increase the overall strength of the fabric, larger fill yarns had to be introduced, but they did not respond the same way as the light yarns since they were not as bendable, and the result was once again crimp back in the warp. There had to be a better way.

Fabric makers knew that small-denier yarns could be woven tighter than their larger-denier counterparts to create a more stable fabric since the thin fibers were more responsive to the pressure exerted by the beater, as well as the heat setting. But these lighter fabrics were not much use on larger boats, so fabric makers had to come up with a way of increasing the strength of the fabric without losing the positive attributes of small denier weaving. With this in mind they started to weave fabrics with both a light, tightly woven base and additional heavier yarns in the warp and fill direction. The light base provided great bias stability, while the heavier yarns added strength. This new fabric was called Square Weave by one manu-



These days you rarely see Dacron sails on the start line of an important race unless it's class mandated. At Block Island Race Week high-tech sails were the order of the day.

facturer. Fabric makers also discovered that they could introduce different kinds of fibers like Kevlar or Vectran into the weave thereby increasing the overall strength and stretch resistance of the fabric that much more.

Hood Sailmakers, for example, had great success including Vectran fibers in the fill of a number of styles of woven Dacron. Challenge Sailcloth did a similar thing including Kevlar yarns in the warp in a series of products they called Pinstripe. For example, the company made a 5.5-ounce Pinstripe fabric to be used for blade genoas on 30-foot boats, or No. 1 genoas on 40-foot boats. The base fabric was a tightly woven 150-denier Dacron with warp fibers consisting of five stripes per inch of 3,000-denier Kevlar. The base gave the fabric great bias stability while the Kevlar added 15,000 DPI (5 x 3,000) to the warp, making it very strong and low stretch for its weight. And there was another great side benefit. The light base provided high tear resistance. Despite the added work (read expense) of incorporating different threads, the results represented a tremendous leap forward.

Other Characteristics of Good Sailcloth

To further emphasize why fabric manufacturing is a complex process, it's important to realize that in addition to creating a material that does not stretch, does not distort under load, is easy to handle, and is rugged enough to withstand gale-force winds as well as fly in light zephyrs, fabric makers need to consider a number of other points, some of which aren't quite so obvious as the factors discussed thus far, but which can be just as important to a sail's performance in the long run.

Fabric Strength

As is the case with fibers and yarns, there are two important strength considerations when it comes to fabric. The first is the breaking, or tensile strength, and the second is yield strength. Breaking strength is obvious. Nobody wants their sails to break apart and if engineers know the point at which a certain fabric fails under tension, they can design accordingly. Yield strength, on the other hand, is a trickier number, although no less important since it tells the sailmaker at which point the fabric, and by extension the sail will start to distort, thereby compromising its aerodynamic integrity. If you use your sails in too much wind, for example, it's unlikely they will blow up unless the fabric is old and UV damaged. What will happen, however, is that the shape will distort and then remain so with the result that, for cutting-edge racers in particular, the sail will be as useless as if it had blown apart. A conscientious sailmaker will let you know the wind range in which any sail can be flown, and you would do well to adhere to their recommendations.

Tear Strength

Another problem with adding fillers and finishes to a woven fabric is that the fabric becomes brittle, making it more susceptible to ripping. Specifically, by adding resin to the yarns they become brittle and tend to break one at a time like a chain of falling dominos, with the result that the tear strength goes down accordingly. If, on the other hand, there is little or no resin the fibers are able to move freely and tend to gather and bunch as the fabric begins to rip. To see this, try tearing a loosely woven material like a dish towel, or stick a spike through the fabric and pull down on it. Instead of simply breaking you will see that the individual yarns tend to slide away from the rip transferring some of the load onto a number of neighboring yarns, effectively forcing them to share the load.

Tear strength, not surprisingly, is important to the overall life of the fabric, and by extension, the life of the sail. Sailboats offer a harsh environment for fabrics, with sharp edges and uncovered fasteners waiting to snag an unsuspecting sail. If the fabric is resistant to tearing, the life of the sail is greatly increased. There are some ways to improve a fabric's resistance to tearing, i.e., a looser weave or less filler, but of course this also means that the fabric is less effective at maintaining its designed shaper under load. As with many things in the fabric-making business, it becomes a compromise between competing interests.

Abrasion Resistance

This is not a huge problem for woven Dacron sails, but does become a concern with some of the more exotic fibers. In some cases, adding resin to the finish can decrease the abrasion resistance of the fabric, while at other times it adds to it. For example, if the body of the sail is rubbing against something like a shroud or stanchion, the resin can add a layer of protection around the sail's many individual fibers. On the other hand, since the resin makes the fabric more brittle, it is more susceptible to abrasion if an edge of the sail or a fold is being affected. Reefing a mainsail, for example, offers many edges and many points for abrasion.

Ultraviolet Degradation

The real problem with all kinds of fibers and fabric is the sun. Sooner or later UV light penetrates the fabric and breaks it down. Fortunately, fabric makers can do a lot to protect the yarns either by adding a UV inhibitor to the individual yarns before they are used to make the fabric, or by dipping the finished panels in a solution that coats the fabric with UV protection. The UV protection itself contains titanium dioxide, which provides whiteness and opacity to the fabric. It also has a very high refractive index—surpassed only by a diamond — and it's this refraction that protects the yarns from the UV rays. The more effective way is to treat the yarns individually, since surface UV coatings are thin and can wear off over time, but it is also more expensive.

Water Absorption

Not only does water attract dirt, which can lead to mildew and other discoloration, it also adds weight. Some fabrics wick and retain water more easily than others, and in a wet environment this can be very important. New fabrics that have the resin finish still perfectly intact repel water much better than old fabric that has had some of the resin break down. There is no use manufacturing a fabric to exacting specifications only to have it increase in weight by 20 percent after lying in the bilge. Many sailmakers are beginning to add water repellents to fabric to minimize water absorption. These water repellents can also be added to old sails to improve their water resistance.

Fabric Smoothness

The friction of the wind passing over the sailcloth adds drag, so it's important to keep the fabrics as smooth and friction free as possible. The resins that coat the fabric present a smooth surface, especially on fabrics made from smaller denier fibers.

Factors That Affect the Price of Dacron Sailcloth

In order to provide a yardstick by which fabrics can be compared, fabric makers rate the performance of different sailcloths by dividing the modulus of a fabric by its weight to determine a number called the “specific modulus.” In most cases fabric makers are striving for a high modulus/low weight fabric, in which case they might incorporate some exotic yarns into a fabric to give it more strength. On the other hand, there are some occasions where durability needs outweigh performance, and in these cases a high modulus/low weight combination will not be the driving factor when designing the fabric. For example if you were choosing a fabric for a Dacron No. 1 racing genoa for your C&C 42 you might consider using a Pinstripe 1500 from Challenge Sailcloth, since the Kevlar yarns would give the sail the performance edge you were looking for while keeping the overall weight of the sail down to around 5.5 ounces. On the other hand if you wanted a No. 1 genoa for cruising to Bermuda you might choose an 8-ounce balanced Dacron that would be heavier, but also have the strength and durability you need for an offshore passage.

Since Dacron was first introduced in the mid-1950s, there has been a lot of development in both the fiber and the fabric. Unfortunately, some of the development is not discernible by casual observation, and the difference between a

top-quality Dacron fabric that will perform well for a number of years, and a fabric that will break down and distort quickly is not easy to see. Four primary factors affect the quality and cost of Dacron sailcloth:

1. **Yarn quality** – The quality of the yarns that fabric makers use to manufacture sailcloth vary in terms of tenacity, modulus, creep, and weaving quality. A high-tenacity, high-modulus yarn that is produced specifically for weaving is the most desirable. It is also the most expensive.
2. **Yarn content** – Most fabrics are either balanced or fill-oriented, and the ratio of warp to fill yarns should correspond to the aspect ratio of the sail, i.e., the ratio of the length of the luff to the length of the foot. High-aspect sails like blade jibs, for example, should be manufactured from fill-oriented fabrics, while low-aspect sails like genoas should be manufactured from balanced fabrics.
3. **Tightness of the weave** – The tightness of the weave varies for a number of reasons, including the size of the yarns used and the amount those yarns shrink. The smaller the denier of the yarn used, the tighter the weave, and the more the yarn shrinks when heated, the tighter the weave. A tighter weave will call for less resin to be used to stabilize the fabric. Manufacturing fabric using smaller denier yarns is more expensive. It requires more shuttle passes and takes more time to weave than a larger denier fabric.
4. **Types of finishes** – Highly resonated fabrics rely on the resin for stability, rather than the integrity of the weave. Those fabrics that have been treated with excessive resins are much stiffer to handle and tend to lose their performance edge once the resins break down. The quality and quantity of the resin greatly affects the overall cost and quality of the fabric.

Taking the above factors into account, the price of woven fabrics can vary greatly. You need to be aware of these differences if you are considering Dacron fabric for your own boat. You get what you pay for.

A Final Word About Woven Fabrics

Once the fabric maker has produced the sailcloth, it goes to the sailmaker to be turned into sails. Sailmakers will tell you that they prefer stiff, flat sailcloth when they are designing and building sails since a rigid surface is easier to cut and sew. Woven fabrics with little or no finish, while nice for the sailor to handle, are difficult for the sailmaker to use because the soft fabric moves around too much and seams tend to pucker while sewing. As with everything in sails, sailing, and sailmaking, it's a delicate balance among differing objectives. Trends and fads have their place in the business and they pull and tug at convention. In the end the products improve and the sails last longer.

Laminated Fabrics

While woven fabrics have stood the test of time, sailmakers are continually looking for new ways to build sails, and in particular for ways to graduate the weight of fabric throughout the sail since the different parts of a sail experience marked-

“the difference between a top-quality Dacron fabric that will perform well for a number of years and a fabric that will break down and distort quickly is not easy to see.”

ly different loads. For example, there is little need to have heavy fabric along the luff or in the body of the sail since these areas are subjected to very little loading. The leech, on the other hand, is an area in which a sail designer needs to be sure to place a fabric with both high modulus and tensile strength. Unfortunately, when woven fabrics were used to build cross-cut sails, i.e., sails built up of horizontal panels of sailcloth, the fabric used for the leech ran all the way across the sail to the luff making any kind of graduation impossible. For a while, vertically panelled sails seemed to hold the answer, and warp-orientated fabrics were manufactured for this purpose. But woven Dacron is not really suitable for building vertical or radial sails because of the crimp in the warp yarns. Warp-oriented nylon, which is used principally for spinnakers, works because the fibers are so small there is virtually no crimp in the weave, and indeed a little fabric give in a spinnaker is a good thing. But for working sails there had to be a better way. Ultimately, laminated fabrics and sails proved to be the answer.

In some ways laminated fabric is similar to woven fabric in that it comes in bolts of cloth from which panels are cut and assembled to make a sail. It differs markedly, however, in the way the various fibers and other materials are joined together. Note that laminated fabrics and sails, although they involve similar technologies to molded sails, are quite different, as will be discussed in Chapter 5. Among other things, with molding technologies the whole sail is laminated at once so that there is no need for pre-made bolts of cloth from a fabric maker. In fact there is an ongoing debate surrounding these two methods and which permits the most efficient bond between the various layers. Companies like North Sails, which makes molded sails using 3DL technology, or Doyle Sails, which uses D4, believe they have the best method. Manufacturers of conventional laminated fabric, however, claim that they are able to bring more pressure to bear on their laminate and therefore are able to use less adhesive, resulting in a stronger, lighter fabric.

Parts of a Laminate

As soon as two layers of fabric, fibers, or film are bonded together it becomes a laminate. It does not matter what the layers are made of (Figure 3.5). Fabric makers have experimented with all sorts of different layers to create sailcloth,

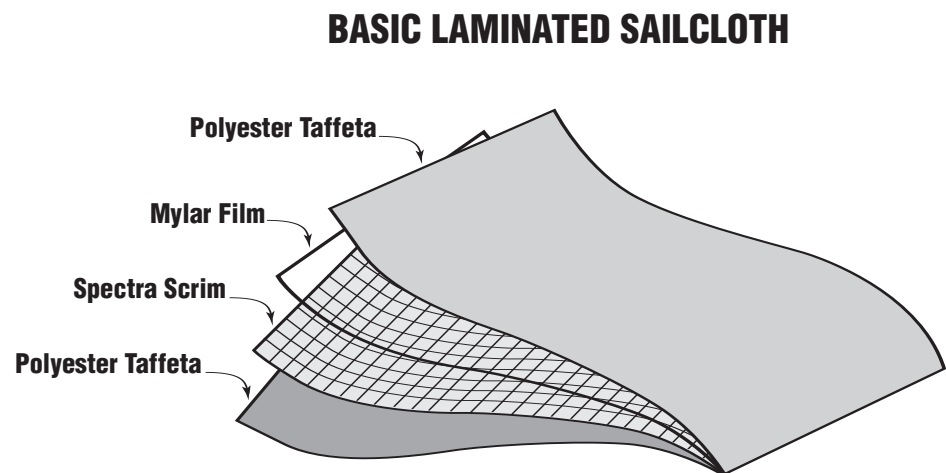

Figure 3.5
Two or more layers of fabric, fibers, or film are bonded together to create a laminate.

but in the end a simple two-layer laminate often works best, with the two basic layers being comprised of load-bearing yarns and a substrate made from a film like Mylar. The yarns provide the strength and stretch resistance along load lines, while the film is there to provide bias, or off-threadline stability. Combining additional layers allows fabric makers to be more comprehensive in terms of creating a fabric that will handle numerous loads running in various directions. Note that an additional advantage of laminating technology is that since the load-bearing fibers do not need to be tightly woven, they can be laid into the fabric as a “scrim,” in other words a loose knit of fibers that, because they are not woven, do not have any crimp in them. The yarns themselves can also be created as flat ribbons as opposed to twisted yarns, so that there will be no tendency for them to untwist when the load comes on them, thereby reducing any potential stretch further still.

Some Background

Laminated sails were first introduced in the late 1970s, making their debut in the high-performance arena of the America’s Cup, and over time they have trickled down to racers and even cruisers at local yacht clubs. The secret behind laminated sails is the adhesive that binds the woven fibers to the extruded substrate or film, since without an adhesive to hold the two together there is no point in even attempting to marry them. Fortunately, chemical engineers have developed adhesives and techniques that make it possible to securely bond the layers while allowing the finished product to remain supple enough to withstand the inevitable stretching and distortion a normal sail endures.

The original laminates were used to make cross-cut sails, but it soon became obvious that a better use would be to make radial sails since there were no restrictions on how the base fabric had to be created. Since it was not necessary to weave the base fabric, there was no problem with having the fabric be fill-orientated to be stretch resistant. Some laminates are actually made with a woven base rather than a scrim, but because the diagonal stretch is taken up by the film, a tight weave is not necessary and therefore there are no problems with crimp. Again, with this technology you can mix and match fibers, yarns sizes, and the number of plies almost at will, all to create a custom fabric for a specific purpose.

The Laminating Process

The basic lamination process is a relatively simple one, although there are many variables. First, a thin film of adhesive is spread on a Mylar film. Then the Mylar and the base fabric, be it a scrim or a woven fabric, are passed between heated rollers that both set off the adhesive and force the adhesive into the fibers. If the fabric calls for more than two layers, the

Mylar film, covered with adhesive, and a base fabric are passed between heated rollers that set off the adhesive and bond the two surfaces.

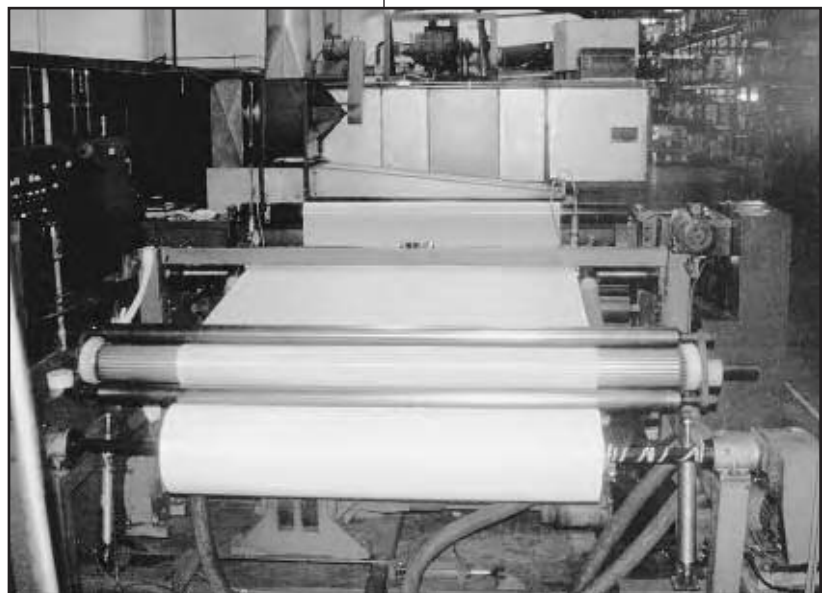

Who Says Sails Don't Stretch?

When I sailed my first Whitbread Round the World Race in 1981, laminated sails were just coming onto the offshore-racing scene. It was still fairly new technology, and because a race like the Whitbread demanded rugged, proven durability, we chose to ignore the latest technology and stick with fabrics we knew we could trust like Dacron and nylon. The boat, Alaska Eagle, was a heavy-displacement aluminum yacht that placed enormous loads on all the gear. Our new Dacron sails were delivered to England where we had been training, and after a series of sail-testing days we marked the halyard positions and sheet lead positions, and noted them in our log book. Then we sailed the long first leg from England to South Africa..

Back then there were no waypoints to keep the fleet bunched together and to shepherd the boats around the west side of the South Atlantic High where the wind would be from behind. Instead we crossed the equator, encountered the southeast Trade Winds and sheeted the sails on tight. It was three weeks of hard, bumpy sailing until we got to Cape Town. For the first half of the trip the sails were fine. They sheeted to the correct positions and held their shape as well as could be expected. It was only once the load really came on the sails and remained there day after day that we began to see a very visible change. When we started the leg the clew heights were well above the lifelines, but by the time we were halfway to Cape Town the clews were barely a foot off the deck, and before the leg was over they were right at the block. The sails had stretched so much that we were unable to trim them properly. Once in South Africa we ordered new laminated sails that not only served us well for the rest of the journey around the world, but were so stable that the clew heights remained the same despite thousands of miles of hard upwind sailing.

process is repeated until the fabric is completed. In theory, this may sound simple enough, but in practice the variables are many. The fabric engineer needs to consider the following points:

1. The choice of adhesive (a closely guarded secret).
2. The amount of adhesive (less adhesive makes for lighter sails).
3. The temperature and speed of the pass.
4. The pressure exerted on the fabric.

In general terms, more pressure brought to bear on the fabric will require less adhesive. When considering the weight of the glue, this becomes an important consideration as the sail designer tries to minimize weight aloft. In the early days there were many cases – some very high profile – of sails delaminating. Today, however, the process has been refined to a point where there is an almost 100-percent success rate with laminated sails. I have sailed around the world on more than one occasion with laminated sails and have them on my own boat. Not a single sail has delaminated.

The Magic of Films

As long ago as the late 1960s, the problems associated with bias stretch led sailmakers to try to incorporate Mylar films in their sails. The reason for this is that, although Mylar and polyester are chemically similar, the way in which they are extruded makes all the difference in terms of their performance characteristics. Specifically, while polyester yarns are extruded as thin filaments with their molecules aligned in a single direction, Mylar is extruded as a film or sheet with the molecules oriented equally in all directions. As a result its resistance to stretch is the same both along and across the panel, and more importantly, on the diagonal. At last there was something that would resist stretch on the bias and sailmakers leapt to build sails using just the film and no fiber. Unfortunately, they encountered a number of problems, not the least of which was that with film-only sails there was no way to control and manipulate the shape of the sail since it is by tightening control lines like the halyard and pulling on a woven sail's bias that you are able to move its shape. Film sails, on the other hand, are not so easily manipulated – turns out that a certain amount of bias stretch is good for the sail after all! There were other problems as well. For example, the sails tore easily without any cross yarns to arrest a rip, and when the sails were sewn together, each needle hole became a potential weak spot. In short, sailmakers could not use the film without the fiber.

It was with the development of new glues to bond the two together that a whole new world suddenly opened up to fabric engineers, making laminated sails not only practical, but eminently desirable. Afterward, as noted above, laminated sails quickly became a part of everyday sail technology, as increasingly sophisticated ways of layering film and fibers were developed

A Closer Look at Film Choices

Since Mylar was first introduced into sailmaking there has been a search to improve upon it, but without much success, especially when compared with the gains made in other areas of sailmaking like design and yarn technology. New films include those made of Vectra, Tedlar, and PEN, all of which have significant drawbacks in terms of sail construction. Vectra, for example, is extruded using a process similar to that of Mylar and has the same high-modulus qualities as the sailcloth. But tests have shown that while Vectra has the strength to carry the loads on a sail without fiber reinforcement, it has a low impact resistance and shatters easily when used in sails. There have been some attempts to double Vectra up with Mylar to minimize its negative qualities, but the added weight and expense are unacceptable.

Tedlar has also been used in some sailcloth applications where it exhibited excellent abrasion and UV resistance. But it is heavier than Mylar, absorbs slight amounts of water and tends to creep over time. The most important breakthrough in film was when Pentex was used to make PEN film. PEN film, which is an extruded version of the Pentex fiber, is actually stronger than Mylar, but tends to be brittle, less resistant to abuse, and prone to shrinkage, which distorts the aerodynamic shape of the sails in which it is used.

Ultimately, the biggest breakthroughs in film have not been in strength or stretch resistance but in the ability to combine it with UV inhibitors. These UV inhibitors protect light sensitive yarns that are paired up with the Mylar from the sun's harmful rays, thereby extending the overall life of the fabric. They use the same titanium dioxide in the film as they use to coat the fibers.

What About Shrinkage?

Shrinkage, as alluded to in the context of PEN film, is a definite problem with laminated fabrics since it distorts sail shape just as badly as stretch. In the case of film, the material itself does not get any smaller, but when a sail is folded into a bag, it gets scrunched up in such a way that it's impossible to spread it out flat again so that the total area becomes less. To illustrate, take a piece of paper, lay it out flat on a table and measure it lengthwise and diagonally. Now take that same piece of paper, scrunch it up into a ball, smooth it out, and lay it back down on the table and measure it again. You will find that it is impossible to get the fabric to lie out smoothly enough to reach its original size since the bending and folding creases the paper, and those creases are difficult, if not impossible to remove from the sheet. The same thing happens with film. Once it has been scrunched up it never quite recovers. Light fabrics are more susceptible to shrinkage than heavier ones because of the thickness of the film. The bad news is that the problem is not likely to be resolved anytime soon.

Scrim

As already noted, in addition to the adhesives that bond the layers together and the films that cure bias stretch, the other real breakthrough in laminated sails was the discovery that it was no longer necessary for the substrate to be woven, or at least not as tightly woven as had been the case with standard Dacron. The result has been laid-up scrim in which the warp and fill fibers are simply arranged in a loose grid pattern that is then held together by the Mylar film (Figure 3.6). The yarns used in scrim are extruded flat rather than round, and because they are simply placed on top of each other there is none of the over and under that causes crimp in a standard weave. When the scrim is laminated, they are held in tension to remove initial stretch from the fabric, and as soon as they are bonded to the film they remain in place and the initial stretch characteristics of laminated fabrics are always very good as a result. The result-

Figure 3.6

A scrim is where the warp and fill fibers are arranged in a loose grid pattern held together by Mylar (photo of scrim below).

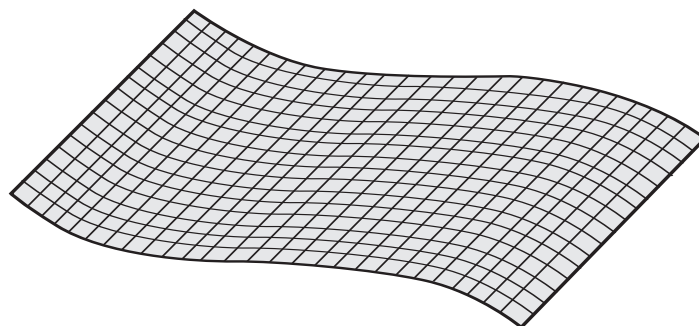

SCRIM

ing gaps between these yarns have been shown to be the key to good laminated sails since the adhesives used in the laminating process work better when they are allowed to adhere to film rather than the fibers.

Fabric makers have also discovered that in many cases a third layer, for example, a taffeta, helps prevent tearing since the fact that the individual yarns do not interlock as in a woven fabric results in a lower tear strength. The taffetas are usually light, fairly loosely woven polyester fabrics. Their job is not specifically to help with diagonal stretch, although they do contribute a little. Rather the taffetas are there for abrasion resistance and overall strength.

Diagonal Yarns

The final piece of the laminate puzzle was the addition of diagonal yarns, which lend some strength to the film when it comes to handling off-threadline stretch. The angles at which the yarns are placed in the fabric have been part of patents, and their number and relative thicknesses are an integral part of the fabric engineering process. It is not as important to have as many diagonal yarns as warp or fill yarns, since if the sail is engineered properly the principal load-bearing yarns will manage most of the loads on the sail. The diagonal fibers come into play when the sail is eased out and the loads no longer travel along predictable load lines or “catenaries.” The good news is that once a sail is eased out, the loads are greatly reduced, therefore having as many fibers there to accept them is not that critical.

Laminated Sails in Depth

Laminated fabrics have come to play an increasingly larger part in the sailmaking industry and their continued growth is assured. There are a number of reasons for this:

1. Lamination is the most effective way of combining materials with different characteristics to maximize the advantages of each.
2. Laminates allow individual fibers to be placed in straight uninterrupted paths. This is the most effective way of getting the most from the fibers and the most efficient way of using a fiber.
3. When films like Mylar or PEN are introduced, the result is an effective way of minimizing off-threadline stretch.
4. As laminates have become more accepted and earlier problems of delamination and mildew have been dealt with, the demand has reduced the prices to a point where they are competitive with Dacron.

Laminate Styles

Because the number of plies is virtually unlimited, and various combinations of fibers and film are readily available, there is no practical limit to the kinds of laminated fabrics that can be created. The only limits are engineering and cost. In the case of some of the giant megayachts, these fabrics are complex creations designed to handle the loads and abuse the sails are certain to undergo. For the rest of the sailmaking world, there are four main construction styles of note.

“Because the number of plies is virtually unlimited, and various combinations of fibers and film are readily available, there is no practical limit to the kinds of laminated fabrics that can be created.”

Type 1: Woven/Film

This is the most basic style of laminated sailcloth, and at the low end might consist of an inexpensive woven polyester laminated to a substrate or film. The film provides stretch resistance while the woven fabric provides resistance to abrasion and tears. The combination results in a relatively inexpensive sailcloth that more than adequately serves its purpose as, say, a performance cruising fabric. If a heavier weight or stronger fabric is required, a second layer in the form of a light taffeta or rugged woven material can be added to the other side of the film (woven-film-woven).

A high-end version of this type of fabric might use a woven Spectra or Vectran layer laminated to a film, where the Spectra or Vectran yarns provide stretch resistance, and the film adds off-threadline stability. Again, this is an effective way of creating a fabric that is both rugged and offers good stretch resistance. A third layer can be added to the other side of the film in this case as well, possibly a light, balanced, tightly woven taffeta to help with durability and bias control. In all cases where a woven material is used, you need to remember that there will be crimp in the fabric and the problems associated with crimp, notably initial stretch, will be inherent in the fabric. If rugged durability and overall stretch resistance is required with a cheaper construction cost, these fabrics are a good choice.

Type 2: Film/Scrim/Film

This construction style results in a low-stretch, low-weight fabric that is excellent for racing sails. The structural fibers are sandwiched between two films and inserted into the laminate in a scrim. That way the load-bearing fibers are used to their fullest potential with no crimp, with the loads going directly onto the fibers. With the fabric laminated film-to-film, the adhesive bonds between the fibers resulting in a strong bond that uses a minimal amount of glue. By eliminating layers of fiber and keeping the amount of adhesive to a minimum, the overall weight of the fabric is kept as light as possible.

The scrims for these fabrics are usually of a high modulus type like Kevlar, Spectra, Twaron, or a combination thereof. Fabric makers add UV inhibitors to the film so that the delicate load-bearing yarns are protected from the harmful rays of the sun. The drawback of these kinds of films is that they are not very rugged or abrasion resistant and get a lot of wear and tear, reducing the life of the sail. As a result only racing programs that replace their sails on a regular basis tend to choose this style of construction.

Using the same engineering lay-up but different yarns and deniers for the scrim allows the fabric maker to have a range of fabrics. For example they can make a fabric for a No. 1 genoa for a 35-foot racing boat made up of a scrim of alternating 400 DPI Twaron and Spectra in the fill, and 1,100 DPI Twaron in the warp. To add some off-threadline performance the fabric maker might add 375 DPI Spectra on the diagonal. On the other hand, in a heavier fabric for a heavy No. 1 genoa on a 55-foot racing boat, the scrim might have the same fill and diagonal yarns as for the lighter fabric, but the warp would be 3,780 DPI Twaron, giving the fabric the strength it needs for the heavier sail.

Type 3: Woven/Film/Scrim/Film/Woven

This construction style is an obvious further development of Type 2 in which woven taffetas are added to the film/scrim/film center in an effort to create a rugged, low-stretch fabric. The “film-on-film” center, as Type 2 is known, includes low-stretch, load-bearing yarns that are then protected by the woven taffetas on the surface of the fabric. These woven taffetas protect the film from both flex fatigue and abrasion, and they protect the core fibers from UV degradation. You can even use light-sensitive fibers like Kevlar and PBO as the load-bearing yarns in the center since they will be protected by the outer layers.

The taffetas can be made of either a lightweight polyester, or a woven Spectra or Kevlar. Note, however, that one problem when combining woven fabrics with scrims is that, because of the crimp in the wovens, their initial stretch is much more than that of the scrim and the scrim ends up by taking all the loads with very little being handled by the outer layers. As a result, for a rugged fabric created for long offshore races such as the Vendée Globe or the Around Alone, Spectra taffetas do help a little in terms of stretch, but their main function is to add durability. This kind of lay-up has been very successful, although the cost of producing the fabrics is quite high.

The Type 3 fabric is also useful for the megayacht market where you need both strength and stretch resistance. Again, because the outer layers protect the inner layers, these inner scrims can be made from high-modulus fibers like Kevlar and Vectran, with the outer layers adding a measure of protection to the inner fibers.

Type 4: Woven/Scrim/Woven

This type of fabric is relatively new and eliminates film from the construction. In high-load applications like sails for megayachts the films have proven to be a liability in terms of longevity and durability. The difficulty, however, has been bonding two woven fabrics together since you get a better adhesion by bonding to a film. Development continues on this kind of engineering and new adhesives show some promise. Doyle Sailmakers, for example, is pioneering this technology specifically for an inventory of sails for the 248-foot *Mirabella V*, the latest generation of super-yachts.

Case Study—Fabric for High Latitude Sailing

I recently had two customers who were building boats for high latitude sailing. One was building an 80-foot sloop and the other a 50-foot sloop. It’s interesting that both customers had firm views on what they wanted, and both went against conventional wisdom with their choices.

Since both boats would be sailing in areas where the conditions were harsh and repair facilities nonexistent, rugged and durable were the principal requirements. Both owners were presented with similar fabric choices, but the emphasis was slanted based on the sizes of their boats. Once a boat gets over 50 feet in length the loads start to increase to a point where it makes sense to invest in a more exotic fabric like Pentex, Vectran, or even Spectra. There comes a point where you need so much of a lesser fabric (like Dacron) to manage the loads that

the price difference is narrowed, and the gains with a stronger, lower stretch fabric become that much more significant. A lot of this depends on the righting moment of the boat, as well as length. Boats that have great stability and are able to carry a lot of sail in heavy air are likely to place more strain on their sails than boats that heel over easily and burn off power. In general, above 80 feet, one should really consider Pentex, Spectra, or Vectran for the inventory. So I was a little bit surprised when the customer with the 50-foot boat opted for Vectran, and the customer with the 80-foot boat chose Dacron.

In each case the fabric choices offered were Dacron, Pentex, Vectran, and Spectra, since all four are proven, reliable, and very durable. Dacron was the cheapest option with Spectra and Vectran quite a bit more expensive. Pentex was more than Dacron, but less than the other two. With constant talk of war in the Persian Gulf the price of Spectra was the most expensive because the price of Spectra inevitably soars when there is uncertainty in the air since its principal use is for the defense industry. The plusses and drawbacks for each fabric were quite evident. Dacron is rugged and easy to repair and fairly easy to re-cut, although heavy and hard to manage. Spectra, on the other hand, has been proven on numerous around-the-world races and will handle the loads of an 80-foot yacht without any problem. Not only that, the sails will hold their shape and be lighter than the Dacron sails by about 15 percent. Vectran, for its part, has the same attributes as Spectra except that it has less favorable UV properties. However, since the fabric proposed had the Vectran fibers sandwiched between UV treated taffetas and most of the sailing would be in the high latitudes where UV degra-

Skip Novak's Pelagic anchored in a cove in Antarctica. Sailing in this harsh environment requires a well-thought-out inventory.



Photo by Skip Novak

dition was not a significant problem, Vectran's UV weakness was discounted. Finally, there was Pentex; cheaper than both Spectra and Vectran, and with significantly less stretch than Dacron.

For all these advantages, however, the owner of the 80-foot boat had a long and favorable history using Dacron; he liked the cross-cut look and figured that because the boat had a centerboard the sails would not be unduly overloaded. Weight aloft was not an important consideration, and sail handling would be done by furling units on the headsails and lazy jacks on the mainsail. Price was a consideration, but not overly so. It was a simple matter of trusting what you know, and being confident in your experience.

The customer with the 50-foot sailboat, on the other hand, stuck with Vectran for a number of different but equally valid reasons. For example, he planned to sail the boat double-handed with his wife, so it was important that the sails be light and easier to manage. Therefore Vectran and Spectra were obvious choices. After further investigation Spectra proved to be too expensive, which made Vectran look even better. Interestingly, from the outset the slight off-white color of the Vectran fabric caught their interest and perhaps even played a role in their final decision. Ultimately, since all the other factors pointed to Vectran being a good choice, Vectran it was.

A number of points become evident after studying this case. First, as stated earlier, there are many ways to make a good sail, and in this case all four of the fabrics presented would have made a fine inventory. It often becomes a matter of preference and a comfort level. In the end, unless the choice is way out of line, a happy customer is one who has played a part in the decision making process. It's never an obvious choice, and sailmakers, knowing that sails are custom-made products, need to place the needs and requirements of the customer first.

Where to Now?

The quest for low-stretch fabric will never end so long as there are racing sailors looking for an edge. Ten years ago it would have been hard to believe that there was any room for improvement on some of the newest laminated fabrics. Looking back at some old America's Cup photographs one can only smile at how outdated that technology has already become.

The America's Cup is still the arena for cutting-edge sail technology, and the last two Cups in New Zealand have sported some of the latest designs and fabrics, including the previously mentioned molded sails and a fabric called Cuben Fiber. Cuben Fiber has revolutionized paneled sailmaking, and the results are extraordinary: light sails that hold their shape over a broad range of conditions with little or no stretch. It may sound too good to be true, but it's not.

What is Cuben Fiber?

You may recall from the introduction to this book, that the sails for the megacatamaran *Team Adventure* were made from a revolutionary new sailcloth called Cuben Fiber, which we chose after weeks of rigorous testing of a number of different types of fibers and fabric engineering techniques. Some of this testing was

“The thing that sets Cuben Fiber apart is the way in which these raw fibers are turned into sailcloth. Once they are laid down . . . the entire matrix is inserted into an autoclave . . . and the loose layers of fibers and film are converted into a single solid sheet of Cuben Fiber fabric.”

very technical and involved measuring the various fabrics for stretch and elongation under carefully controlled laboratory conditions. Other tests, however, were decidedly low-tech. At one point, for example, I took pieces of Cuben Fiber, taped them to the antenna of my car, and drove on the highway for a few hundred miles before retesting the fabric. The idea was to see how much strength and stretch resistance the fabric lost after being fluttered for long periods of time. I also froze pieces of fabric in my freezer and then tested them to see if the cold conditions of the Southern Ocean would have any effect on the integrity of the fabric. It turned out that they wouldn't.

Cuben Fiber, according to company literature, “is a complex laminate that uses unidirectional pre-preg tapes of in-line plasma-treated Spectra 2000 fibers spread to mono-filament levels.” What this means is that the company uses highest quality filaments of Spectra, not yarns, with each filament already impregnated with adhesive. The advantage of using untwisted filaments rather than twisted yarns is that the filaments do not attempt to untwist and straighten out once they come under load. The result is much less initial stretch. There is also no crimp, which, as we have already learned, eliminates yet another source of fabric distortion. Impregnating individual filaments of Spectra with adhesive allows the engineers to be more precise with the amount of adhesive they use, thereby allowing them to save weight in the finished fabric.

These points are important when attempting to create a fabric that is light and has zero detectable creep or crimp, but they are not the main reason why Cuben Fiber is so much more advanced than regular laminated fabric. The thing that sets Cuben Fiber apart is the way in which these raw fibers are turned into sailcloth. Once they are laid down per the engineers' specifications, the entire matrix is inserted into an autoclave, a massive oven where very high temperatures can be introduced and monitored with precision, and the loose layers of fibers and film are converted into a single solid sheet of Cuben Fiber fabric. The weight and strength of Cuben Fiber is determined by how many layers of raw fiber and film go into the fabric design.

The History of Cuben Fiber

During the 1992 America's Cup, the U.S. syndicate *America*³ began some highly secret fabric development in an attempt to find a technological edge that would help it win the Cup. Bill Koch, the syndicate head, was sure there were some gains to be made not only in sail design, but in fabric engineering, so he set his design team about creating something radically different. The result was a fabric manufacturing process that was so advanced when compared to the way conventional sailcloth was being made that the process was patented. Using this fabric *America*³ went on to win the America's Cup. The press dubbed the new wonder fabric “America Cube Fiber,” later shortened to Cuben Fiber.

Eventually a company named America³ Technologies was formed to produce this fabric, and once the Cup was over it set about introducing the material to a broader market. The Cuben Fiber factory is located in the Arizona desert in a facility usually reserved for top-secret government work. Because the Cuben

Fiber used for *America*³ sails was so labor intensive to manufacture and the raw materials so costly, it was assumed that only those sailing projects with the largest budgets would be able to afford the fabric. Since it was the company's objective to introduce the product to a wider market, company executives decided to produce a simpler version using lower performance fibers and a simplified manufacturing process. But the effort was not very successful and the company was abandoned at the end of 1996. Then in 1997 a new company was formed, picking up the remnants of America³ Technologies and starting a new commercial enterprise to produce an improved version of the fabric that won the America's Cup. The new company, Cuben Fiber Corporation, still manufactures this cutting-edge fabric today.

Making Cuben Fiber

There are various steps to making Cuben Fiber with the number of steps dependent on the engineering of the finished fabric. For example, a heavy fabric for use on a megayacht mainsail will have more steps than a light fabric for use as spinnaker material. The basic process is the same; it's just that the heavier fabrics require more layers, hence more steps.

The foundation of all Cuben Fiber fabrics is tapes of pre-preg fibers 30 meters long and 30 centimeters wide. The fibers can be either Spectra 2000, which is the most common, or carbon. To create the tapes, parallel fibers of Spectra or carbon are applied to a paper carrier with a light adhesive, and these tapes are then laid by hand to a base paper after which the paper carrier is removed. These tapes can be applied parallel to each other or at an angle, with the number of tapes and the angle at which they are applied being predetermined by the fabric engineering to form the basic structure of the Cuben Fiber cloth.

The next step is called pre-lamination, during which the matrix is applied to a substrate like Tedlar or Mylar to further stabilize the product. Then the raw fabric is moved into the autoclave where precise temperature and pressure can be applied to the fabric to bind the various components together. The exact temperature remains a trade secret – in fact, a number of Cuben Fiber's procedures are secret – but the result is that the various layers are molded into one and what enters the oven as a loose-knit thick layer of film and fiber comes out as a flat, smooth, supple, plastic-like fabric ready to be sent to the sailmaker. The sailmaker then treats this fabric much the same as he would a bolt of cloth, with the main differences being that these sheets of Cuben Fiber are only 30 meters long, rather than hundreds of meters long like a regular roll of cloth, and the fiber orientation is engineered specifically for certain parts of the sail. For example, the sailmaker will not use the same sheet for the high-load areas such as the leech of a maxi-catamaran mainsail as he would for the body or even the luff of the sail.

By manufacturing fabric in this manner, engineers are able to retain all the excellent properties of Spectra (low initial stretch, excellent flex, and UV resistance) while negating the fiber's problems with creep. They also manage to produce sails as strong as their "regular" Spectra counterparts at about half the



The manufacturers of Cuben Fiber hope to see their fabric on race courses around the world as common as other types of fabric.

weight (depending upon the size of the sail). For example the fabric that was made for *Team Adventure* weighed 11.4 ounces and had a DPI of 160,000 compared to a standard Spectra fabric of equal strength that weighed 18.0 ounces and only had a DPI of 94,000. In addition, the flex properties of Cuben Fiber are nothing short of remarkable. A regular aramid laminate loses up to 80 percent of its strength after being folded 250 times. A piece of Cuben Fiber of similar weight loses less than one percent of its original strength after being subjected to the same folding routine.

Is Cuben Fiber Cost Effective?

When considering Cuben Fiber it's important to keep another point in mind: the bigger the boat, the higher the loads. At some point the cost differential between conventional fabrics like Spectra, Vectran and Kevlar, and Cuben Fiber becomes less noticeable. You simply need so much regular fabric to manage the loads that the Cuben Fiber option begins to look reasonable. For smaller boats, the gap is still quite large. For example a high-tech Kevlar mainsail for a 55-foot racing boat might cost \$14,000, a Spectra one \$15,000 while a Cuban Fiber mainsail would run around \$25,000. Still, if you are a solo sailor who has to reef and unreef your mainsail alone on dark and stormy nights, a light mainsail quickly pays for itself. The same applies to spinnakers that do not break. For example, you can sail over a Cuben Fiber spinnaker without it shredding. Try doing that with a nylon spinnaker, and you will soon be buying a new sail. In short, despite its cost, Cuben Fiber is here to stay. Some sailors will always be willing to pay for the very best, and if they deem Cuben Fiber paneled sails to be better than a molded sail, they will pay the extra cost. It may be a while before this technology is available to the masses of sailors seeking a competitive edge. But like most new technologies, the price will no doubt come down as the process gets refined and the demand increases.

Chapter 4

A PRIMER OF PANEL LAYOUTS

Different Layouts for Different Fabrics

There are two equally important aspects to sail design: aerodynamic shape and engineering. Aerodynamic shape refers to the curved foil that the sail will present when it is flying under certain conditions. Engineering refers to the various fabrics and fibers that will be used in building this foil and the precise manner in which they will be put together. In fact, these two aspects of sail design go hand in hand since a perfect shape is useless if it distorts when a load comes on the sail. Similarly, an over-engineered sail is equally useless if its shape is not conducive to good performance. This balance between shape and engineering is a delicate one, and the process starts with a careful analysis of the various loads that the sail will undergo when it is being used. Once the sail engineer knows precisely what loads the sail will encounter he can build it accordingly using just enough fiber and fabric to handle the anticipated loads without any unwanted stretch or extra weight.

This load analysis has two parts to it. The first is called finite element analysis, in which a sophisticated computer program simulates the sail flying in various wind strengths and angles, and then graphically represents the different loads in the sail. The second involves calculating the exact strength and stretch resistance of each individual fiber and the finished fabric that is to be used in the sail. As discussed in Chapters 2 and 3, a good fabric engineer will know both the tensile strength and yield strength of the various fibers, and will be able to provide the sail designer with this information so that it can be factored into the engineering process. The designer can then take full advantage of the strength and stretch attributes of the sailcloth and incorporate them into his design. The goal is to keep the sail as light as possible, but still strong enough to be usable throughout its designed wind range without changing shape. Panel layouts and corner engineering are also an important part of this process, although before we look at this area in more detail, we need to take another look at the critical subject of load analysis.

Finite Element Analysis

Finite element analysis programs came about because of the complex nature of some of the engineering problems faced not only by sail engineers, but by engineers in general. For example, it's fairly easy to calculate how much a steel beam will deflect when it is suspended between two points. It's also fairly easy to calculate the loads a sail will be subjected to under a specific set of conditions. The problem, however, is that the conditions never remain the same for more than an instant. Wind strength, waves, heel angle, air density, and a myriad of other factors come into play. In order for the engineer to calculate how the fibers and fabric will respond to the different conditions, he needs to break the entire problem down into small, solvable problems, and then feed this information into a finite

“... a perfect shape is useless if it distorts when a load comes on the sail.”

element analysis program that will be able to solve the larger complex problems that result. The small, solvable problems can be expressed as mathematical algorithms that can then be interpolated into the engineering requirements for the more complex problems. Only by knowing the answer to the most basic of equations can the larger engineering problems be solved.

The sail designer starts with some basic information. He has the geometry of the sail, the designed shape and the anticipated wind range for the sail. All this information can be entered into the finite element analysis program, which will then represent the sail graphically on a computer screen. Once he has all this information in place he can begin to manipulate the conditions. He can increase the wind strength and see what result it has on the fabric. He can move the sheet lead position and see how the load paths in the sail change. He can also alter the wind angle and ease the sheet to watch how the loads in the sail will travel along different catenaries. Since a sail is an object that can be infinitely manipulated, and the wind is an infinitely variable element, another job of a sail engineer is to decide which parameters to engineer the sail around. For example, if he is designing a headsail for an America's Cup boat that he knows will only be used on an inshore course for sailing as close to the wind as possible, he would not bother too much about wider wind angles. Instead, he would have the computer program simulate the sail

LOADS IN HIGH-ASPECT HEADSAIL

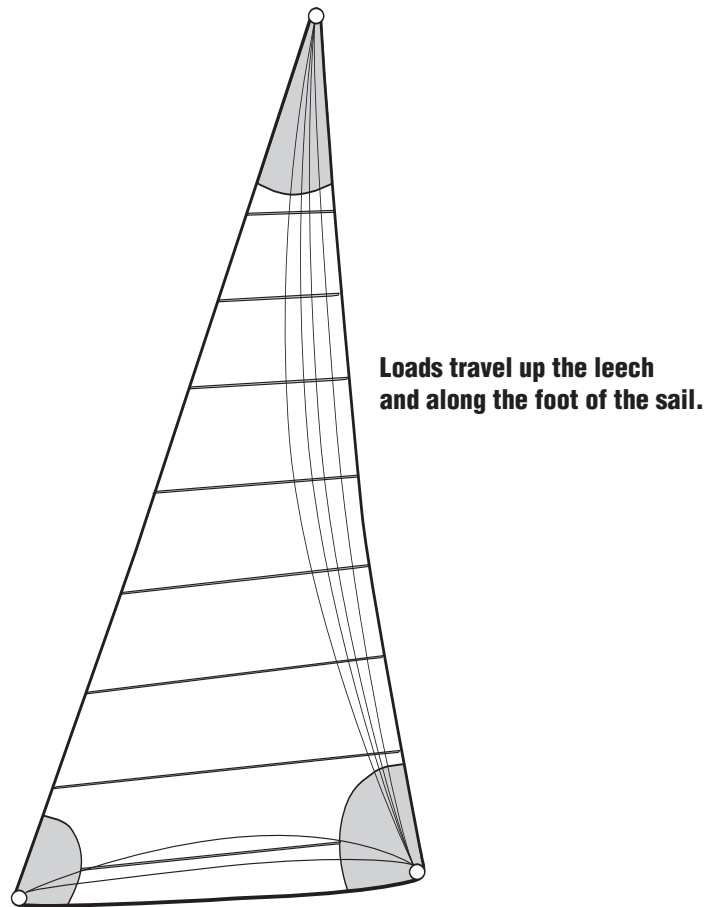

Figure 4.1

When sailing on the wind, a high-aspect sail like a blade jib will have the bulk of the load travel almost directly up the leech of the sail with less stress along the foot.

being used within its designed wind range sailing hard on the wind and see what loads the sail encounters. If, on the other hand, he is designing a headsail to be used on an Open 60 sailing in the Southern Ocean he would know that the sail would never be used in a hard-on-the-wind situation. Rather, the sail would be used reaching and running. Therefore, engineering the sail for dead upwind conditions would not make any sense. The same applies to designing a sail for a cruising boat or a smaller one-design boat like a Soling or a Flying Scott. The amount of analysis for these sails will not be as much because the uses are less complex, and the time spent doing the analysis adds to the cost of the sail. But some kind of analysis is still important for creating the best possible all-around sail.

Note that the loads in a sail are also affected by the geometry of a rig, and in particular the aspect ratio or height-to-width ratio of the sail. For example, when sailing on the wind, a high-aspect sail like a blade jib (Figure 4.1) will have the bulk of the load travel almost directly up the leech of the sail with less stress along the foot. A low-aspect sail like a No. 1 genoa, on the other hand, will have the loads travel more toward the center of the sail rather than concentrated along the leech. It will also experience greater loads along its foot than the high-aspect sail (Figure 4.2). By knowing where the loads fall and combining this information with the strength and stretch resistance of the individual yarns, the sail designer can begin to develop an overall picture of an optimal panel configuration.

LOADS IN LOW-ASPECT HEADSAIL

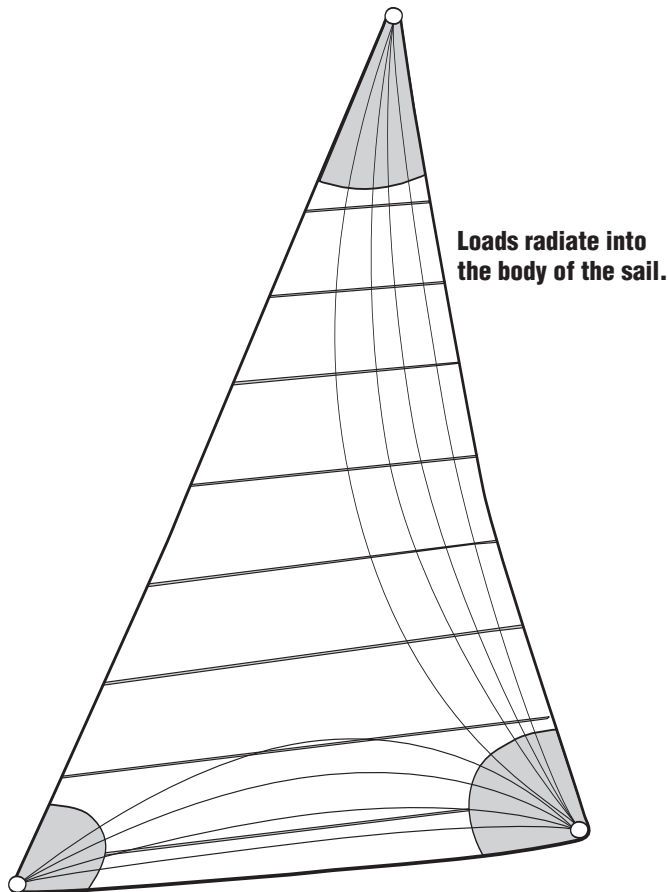
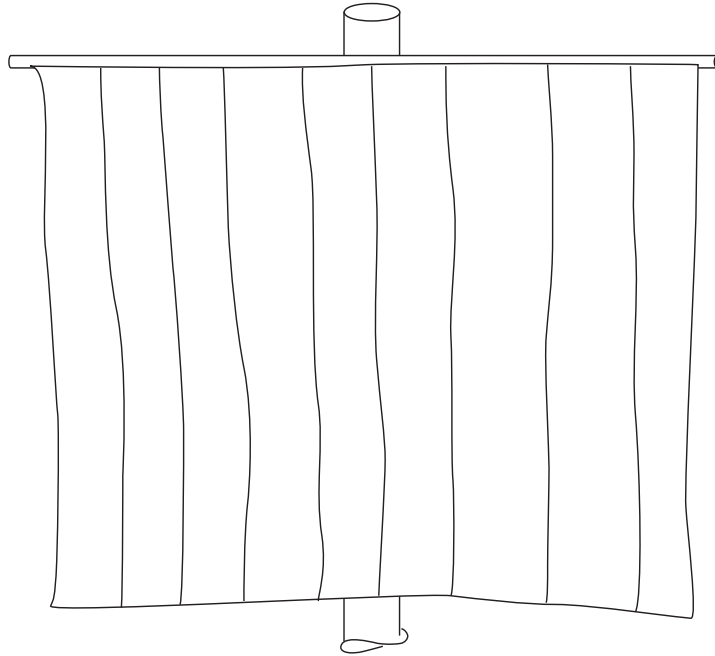

Figure 4.2

A low-aspect sail will have the loads travel more toward the center of the sail rather than concentrated along the leech. It will also experience greater loads along its foot than the high-aspect sail.

SCOTCH-CUT SAIL**Figure 4.3**

Back in the days of square-riggers and trading schooners all sails were made with their panels laid parallel to the leech of the sail in what was referred to as a Scotch-cut pattern.

As you will see in future chapters, the art of aligning yarns along specific load catenaries has become a sophisticated process, far more complicated than in the early days when there were only a few ways to configure a panel layout. As noted in Chapter 3 many different styles of fabric are available, and a number of different construction techniques are also available. Fortunately, it's not rocket science, and understanding even a little about how and why sails are built in a particular manner will go a long way toward helping you make the appropriate decisions the next time you are in the market for a new sail.

Mitre- and Cross-Cut Sails

Before we look at some of the latest sail designs, it's once again important to look to the past. As was the case with sail fabrics and yarns, if we understand how we got to where we are today, we will have some idea of where we might be going. Sail engineering is all about making good use of raw materials, both raw fibers and sailcloth.

Back in the days of square-riggers and trading schooners all sails were made in much the same way, i.e., with their panels laid parallel to the leech of the sail in what was referred to as a Scotch-cut pattern (Figure 4.3). This was true for both square sails and triangular headsails, despite the fact that they were subjected to markedly different forces. Then in the middle of the last century a company by the name of Ratsey and Lapthorn Sailmakers, based in Cowes on England's Isle of Wight, realized that fill yarns had less stretch than their warp counterparts, and that this fact could be used to some advantage in terms of sail shape. Specifically, the company discovered that by rotating the fabric 90 degrees, it was suddenly able to achieve a moderate

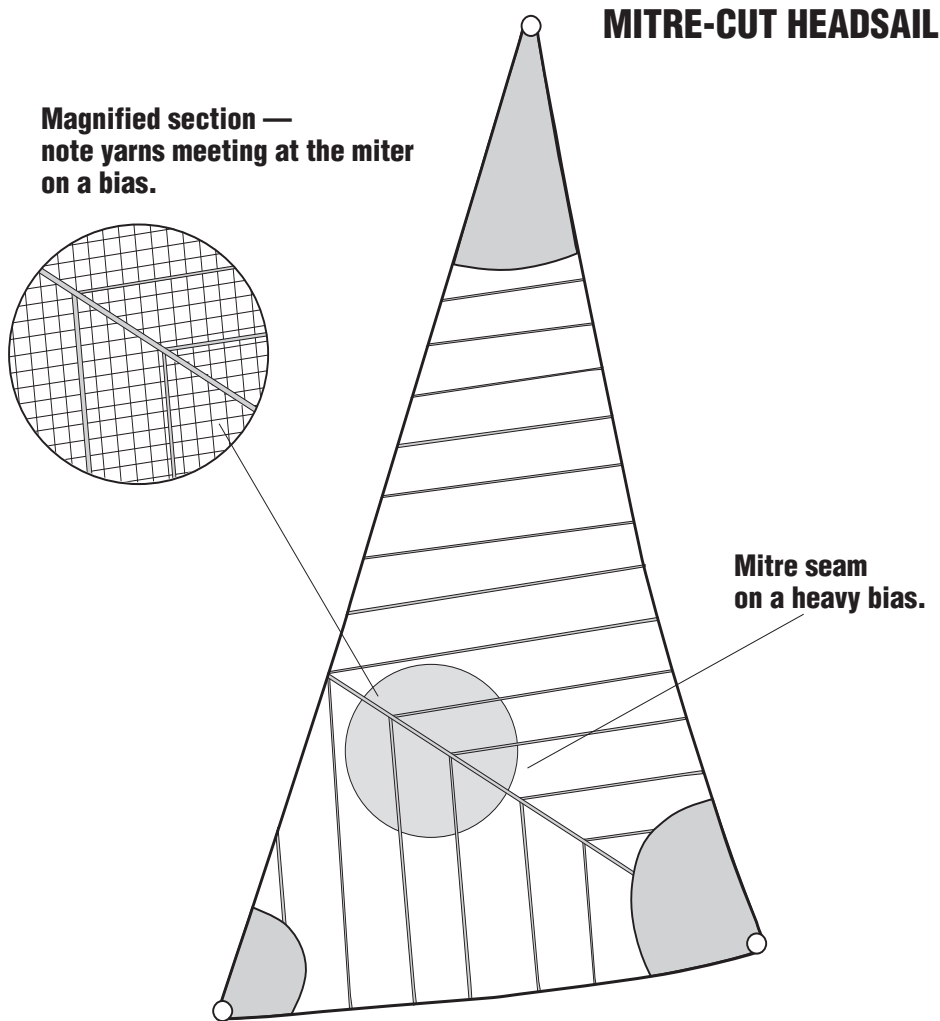
**Figure 4.4**

The panels meet in the body of the sail with adjoining panels cut at an angle to both the warp and fill yarns on what was called a heavy bias.

amount of leech control, something that had until that point eluded sailmakers. For mainsails, where two out of three edges are supported by rigid spars, they ran the fabric all the way across the sail from the leech to the luff in what came to be called a cross-cut pattern. For the headsails, which were only supported along the luff by a headstay, they ran the panels perpendicular to the leech, and perpendicular to the foot as well so that both parts of the sail would benefit from the stretch-resistant fill yarns (Figure 4.4). The panels met in the body of the sail with adjoining panels cut at an angle to both the warp and fill yarns on what was called a heavy bias. Fortunately, the middle of most sails is a low-load area so this bias didn't result in too much distortion, although it could be very difficult to get the sail to look good when there was so much opportunity for stretch. In the old days, when sailmaking was more art than science, sailmakers were often judged by how well they could sight and cut the mitre line.

As designs developed and sailmakers gained some say in the way fabrics were woven, they were able to get fill-oriented and balanced fabrics made that, depending on the aspect ratio of the sail, could be used to build increas-

Figure 4.5

As sailmakers gained some say in the way fabrics were woven, they were able to get fill-oriented and balanced fabrics made that could be used to build increasingly efficient cross-cut sails, both headsails and mainsails.

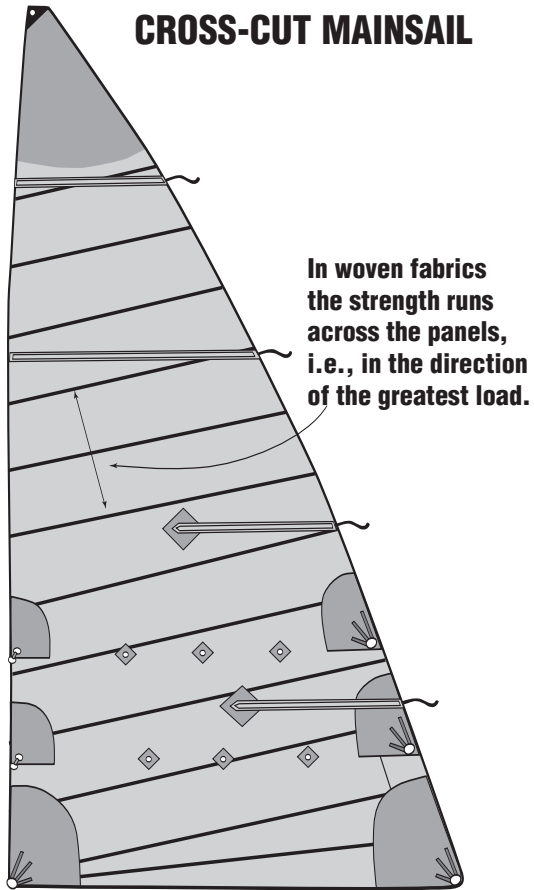

Cross-cut Dacron sails are the most common sails seen on weekends as small cruising boats head out for a sail.



ingly efficient cross-cut sails, both headsails and mainsails (Figure 4.5). For example, as Figure 4.2 on page 53 shows, a low-aspect sail like a No. 1 genoa of the kind used on an old IOR racer has the loads fairly evenly distributed throughout the sail. Therefore, if you had to choose a single fabric it would likely be a balanced one. If, on the other hand, you were choosing fabric for a No. 3 blade jib where the loads run right up the leech of the sail, you would definitely choose a fill-oriented fabric (Figure 4.6). As fabrics became more sophisticated and sailmakers gained a better understanding of their craft, sail designs improved, and the demands for better sails increased as well. The quest for light sails that did not stretch when they came under load remained a top priority for sail engineers.

A Case for Multiple Plies

The fact that the fabric along the luff of sails was overkill was not lost on sailmakers, but until they figured out that fabric could be plied, or made up of multiple layers stacked on top of one another, there was little they could do about it. Sails were engineered for the loads on the leech and the excess fabric strength at the front end (generally in a low load area) got a free ride. When I worked for Hood Sails in the early 1980s we had a lock on the maxi-boat market. Maxi boats back then were 80 feet long, giants for their time, and the sail inventories consisted of five or six headsails of varying sizes and weights,

HIGH-ASPECT CROSS-CUT HEADSAIL

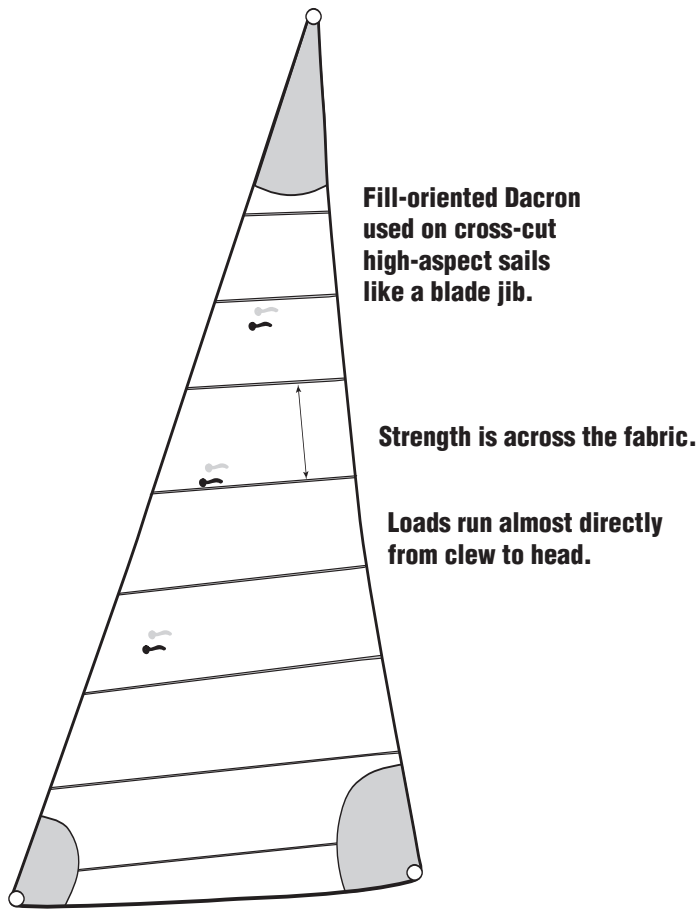

Figure 4.6

Choose a fill-oriented fabric for a No. 3 blade jib where the loads run right up the leech of the sail.

plus a number of other sails like staysails and spinnakers. Some of the boats carried 15 to 20 sails on board each time they left the dock to go racing, which represented a tremendous bulk. It did not make any sense to remove excess weight from the boat in the form of spare tools and unneeded toothbrushes when the bilge was stuffed with heavy, overbuilt sails. When they were wet, which was much of the time, it was even more of a problem.

Crescent-Cut and Saw-Tooth Sails

Partly out of a desire to save overall weight in the boat, and partly in an effort to engineer more efficient sails, sailmakers started to manufacture sails that had a relatively light base fabric, then added a second ply of woven Dacron along the high load area, i.e., the leech. This development took place in the early 1980s and initial forays into two-ply sails, or sails that had heavier fabric up the leech were not a total success. The point where the different fabric strengths came together, for example, was an area that caused problems since a crease or gutter quickly formed where the seam had to try to accommodate the contrasting stretch characteristics of the different fabrics. The first designs simply had the fabrics joining along an imaginary line that ran parallel to the leech (Figure 4.7). As sailmakers began to recognize that there was

Figure 4.7

The first designs had the second ply joining the single ply along an imaginary line that ran parallel to the leech.

MULTIPLE-PLY HEADSAIL

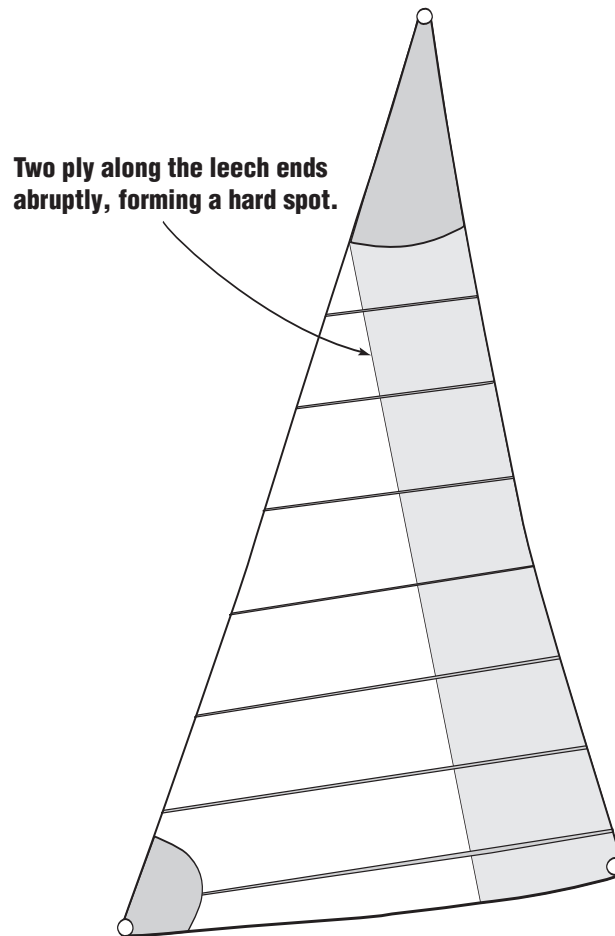

more load toward the head and clew, and less in the middle of the sail, some started to end the second ply in a crescent shape (Figure 4.8), while others tried their own configurations with the result that the saw-tooth sail (Figure 4.9) and other aptly named sails became part of sailmaking jargon. In each case, the basic idea remained the same. Use heavier fabric where it was needed and keep the rest of the sail light.

Another advantage of these two-ply sails was that they allowed the designers to combine fabrics in a sail. For example, they could use a balanced Dacron for the base fabric and a fill-oriented Dacron for the second ply up the leech. This way the yarns were being used to their fullest potential. They even tried three-ply sails, but the added expense of building the sails did not show commensurate gains in performance. After much analysis and trial and error, sailmakers found which fabrics could be plied and matched with others and that if they carried the transition point further into the body of the sail there was less chance of a problem occurring. It was a cumbersome process and sail engineers knew there had to be a better way. Fortunately, it was just about this same time that laminated fabrics began gaining a foothold in the industry.

CRESCENT-CUT HEADSAIL

Two ply along the leech ends in crescent for an easier transition.

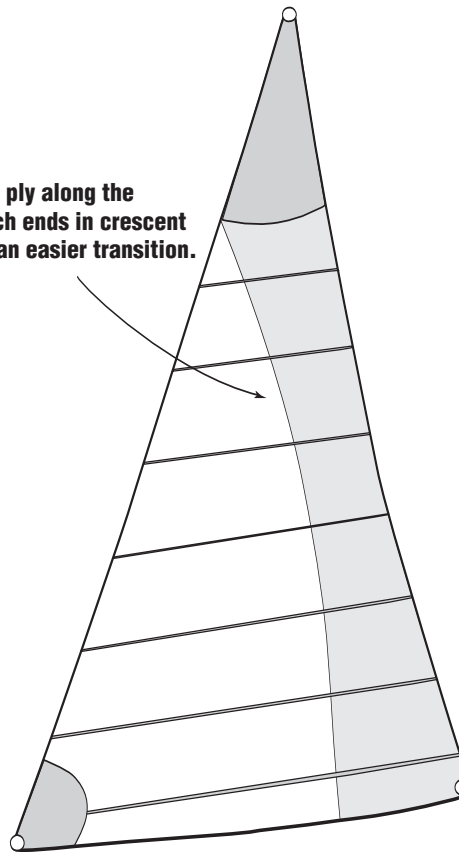

Figure 4.8

SAW-TOOTH HEADSAIL

Two ply along the leech ends in a saw tooth for a smoother transition.

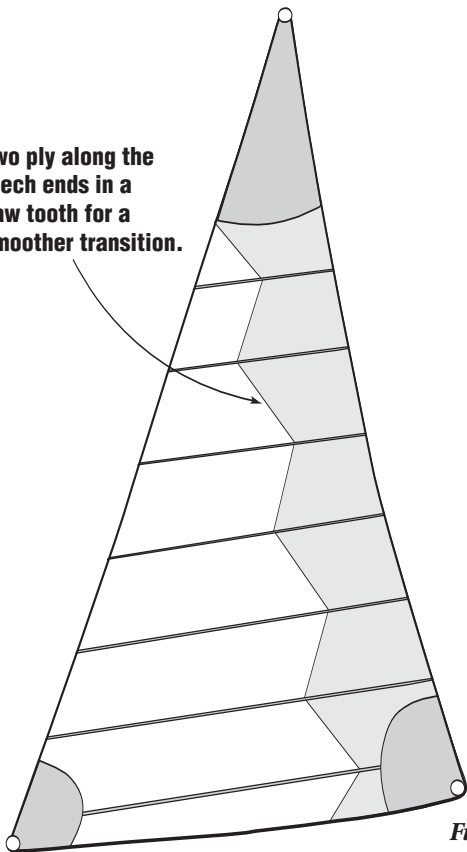

Figure 4.9

Figures 4.8 and 4.9

As sailmakers began to recognize that there was more load toward the head and clew, and less in the middle of the sail, some started to end the second ply in a crescent shape (Figure 4.8), while others tried their own configurations resulting in the saw-tooth sail (Figure 4.9).

Radial Sails

While cross-cut sails were built from woven Dacron, laminated fabrics allowed sailmakers to build both cross-cut and radial sails depending on how the fabric was engineered. When the fabrics were laminated the scrim was laid so that the strength in the fabric could run in the warp direction, the fill direction or both. Fill-oriented laminates were still used to build cross-cut sails, while warp-oriented laminates were used to build radial sails, i.e., sails in which the panels were not just stacked up parallel to the foot. Sailmakers had been building tri-radial

Figure 4.10

Warp-oriented laminates were used to build radial sails, i.e., sails in which the panels were oriented along the load lines, not just stacked up parallel to the foot.

RADIAL HEADSAIL

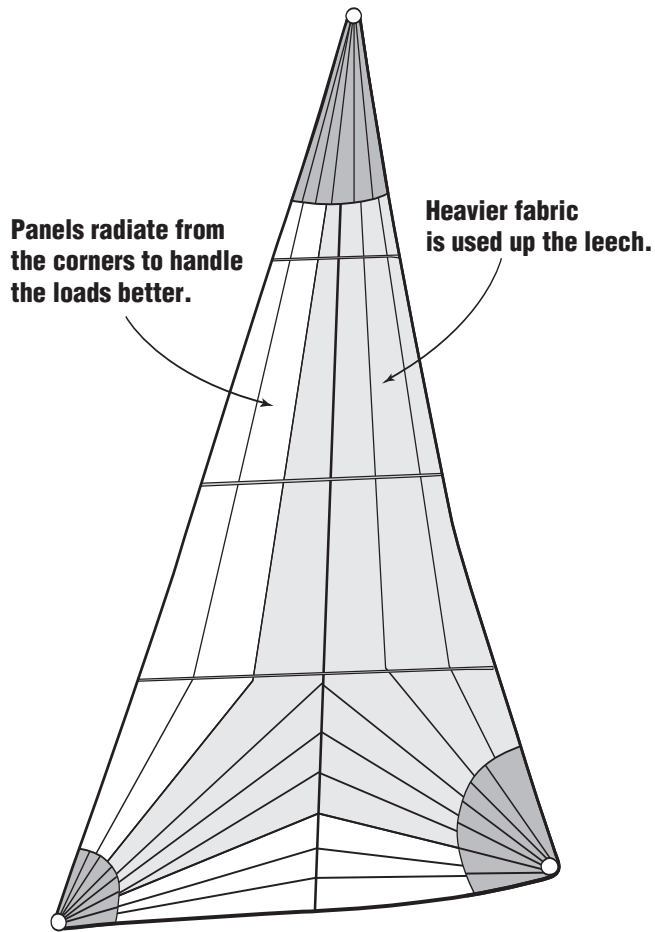

Radial sails are common on the race course where fabric efficiency is key to saving weight and minimizing stretch.



spinnakers for some time so the concept of orienting the panels along the load lines was not new (Figure 4.10). It was just that this was the first time they could build working sails with a tri-radial panel configuration.

One of the principal benefits of radial sails is that the sail designer can engineer sails with different fabrics in different areas of the sail to address specific loads. In other words, heavier fabrics can be used along the leech of the sail or at the head and clew where loads are highest, while lighter fabrics can be used in lower load areas like along the luff. These fabrics can differ in terms of overall weight and specific lay-up. They can also differ in terms of the types of fibers and yarns used to carry the load. For example, the sailmaker can design the sail with low-stretch Kevlar yarns in the high-load areas and a regular polyester in the rest of the sail. In doing so, he can keep the cost of the sail to a minimum while still gaining the maximum benefit from the exotic fibers. If the sail is going to be used on a race course, the sailmaker can add durable, chafe-resistant panels through the foot area to take the abuse handed out each time the boat tacks. If the sail is going to be used for long cruising passages, similar patches can be used in other high-chafe areas, for example, where a mainsail rubs against shrouds or spreaders. The same

can be done for woven cross-cut sails but the patches are added on later. Incorporating them in the original design is a more efficient way to build a sail.

Mainsails and Bi-Radial Sails

Of course, sails are used not only for sailing upwind, but on reaches and runs as well. Mainsails in particular have to be able to perform on every point of sail. Some boats, like those that compete in Olympic events, the America's Cup, or other inshore events, spend most of their time sailing either hard on the wind, or sailing deep off the wind, while others, like those that compete in long-distance offshore events spend much of their time reaching and running. Much like headsails, when sailing hard on the wind the principal loads on a mainsail go directly from the mainsheet onto the clew of the sail and then straight up the leech. As soon as you bear away, however, the loads are decreased and extend further into the body of sail, creating a whole new engineering problem.

In the case of racing sails used on an upwind/downwind course, for example, the sailmaker may choose to build a bi-radial main (Figure 4.11) with load-bearing gores radiating out of the head and clew only – bi-radial meaning that there are only two sets of panels radiating out from the corners, i.e., the head and clew. Although the body and tack of the sail will be subjected to somewhat higher loads on the

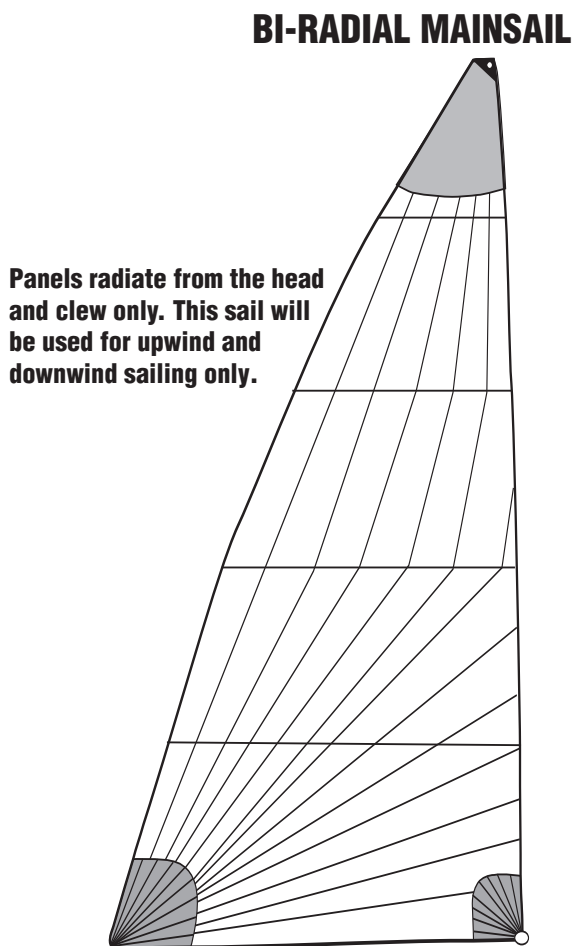

Figure 4.11

A bi-radial main with load-bearing gores radiating out of the head and clew only – bi-radial meaning that there are only two sets of panels radiating out from the corners.

downwind leg, as soon as the racing sailor reaches the windward mark and bears away, the loads on the sail immediately decrease so that even though the loads may be redistributed, there will still not be any need for tack gores.

If, on the other hand, the sail is being designed for a passagemaker, the sailmaker will want to deal with a significant load on the tack since the sail will be used for reaching and running in all kinds of conditions. Therefore strong tack gores are necessary and the sail will be tri-radial in construction. In the beginning of this book it was made clear that your sailmaker needs as much information about your sailing plans as you can give. This is a perfect example of how different sailing styles can result in a need for different sails.



Sails have become far more sophisticated than a simple tri-radial configuration. Here the panels change direction along the load lines in the sail.

Aligning Fabric Along Load Lines

Thanks to continuing research and development, many racing sails are no longer tri-radial in the true sense of the word. Sail designers now have very accurate load plots to work from and it's their job to make use of fabric in the best possible way to accept those loads. Loads are not linear and they do not change direction uniformly and at convenient places. In fact, not only do they bend around a catenary, the curve changes when the heading of the boat changes relative to the wind. Many sail designers now use panels that radiate out from the corners of the sail and then bend the panels within the body of the sail as best they can to match the anticipated loads. In many ways, the more bends in the fabric, the better the sail, although building such sails is quite labor intensive and the more panels needed for construction, the higher the cost of manufacturing the sail. Again, it is a balancing act between trying to make an effective sail and keeping prices reasonable.

Asking Good Questions

The sailmaker's choice of fabric styles and weights are vast. How he uses them to his best advantage is equally infinite. The combinations are endless. It always comes down to the single most important part of the sailmaking process: an understanding between the sailmaker and customer. You need to be clear about what kind of sail you have in mind and how you plan to use it; you also need to be sure to give that information to the sailmaker even before he works up a quote. Otherwise, it's up to him to guess, which is why sailors often get different quotes from different sailmakers who recommend different sails and fabrics at vastly different prices. It's no wonder customers get confused if the sailmakers themselves are working in the dark. Below are some points to think about when talking with your sailmaker about a new sail.

- Do you plan to race or cruise?
- If both, what is the balance between racing and cruising?
- What is your level of expertise?
- Do you really know how to trim sails?
- Is longevity more important than performance?
- Is sail handling important or would you sacrifice that for performance?
- Do class rules limit the number of sails you can have on board?
- Are you planning on coastal cruising or are you going transoceanic?
- If you are going offshore how many people will be on board?
- Do you like to sail short-handed?
- Is stowage an issue on your boat?
- Will you be in an area where it's easy to get a sail repaired?

Armed with information and dozens of fabrics to choose from, the sailmaker can design and build you a custom sail that meets your needs. It's true that two sails built from two different fabrics with two different panel layouts can do the job for

“It always comes down to the single most important part of the sailmaking process: an understanding between the sailmaker and customer . . . It's true that two sails built from two different fabrics with two different panel layouts can do the job for you equally well. Sailmaking is an inexact science; there is still plenty of room for art and interpretation. But that doesn't mean that all sails will perform equally well for your style of sailing.”



At the end of the day it still comes down to the skill of the helmsman and crew, but light, low-stretch sails can only help.

you equally well. Sailmaking is an inexact science; there is still plenty of room for art and interpretation. But that doesn't mean that all sails will perform equally well for your style of sailing.

A New Generation of Sailmaking

Of course, now that you have finally figured out how the fibers and fabrics are used to make sails, the sailmaking world has taken another giant leap forward leaving you behind once again. The days of cross-cut and radial sails are slipping into the past as new sailmaking technologies find a foothold in the industry and become more widely accepted. Once the exclusive domain of the racer, exotic construction techniques like North's 3DL, UK's Tape Drive, and Doyle's D4 are becoming mainstream. In fact, they are being built and marketed to the weekend sailor and offshore passagemaker as well as out-and-out racers.

We will look at these technologies in more detail in the next chapter, but remember one thing. Newer or more expensive is not always better, especially in the case of sails. If weight aloft is of no consideration to you or your sailing plans, then you do not need the latest high-modulus, low-weight wonder fabric. In fact, if durability and ease of onboard repair are important, then you should definitely think twice about buying that fancy 3DL sail, since you might very well be better off with a high-performance Dacron. If, however, performance is king, then it most certainly makes sense to look at the latest sailmaking technologies, decide which one makes the most sense to you, and then go for it. An educated consumer is in a powerful position. Know what you want by knowing how you plan to use the sails, and you will be satisfied with the result.

Chapter 5

MOLDED SAILS

The Latest Sailmaking Technologies

The changes in the sailmaking industry have been nothing short of astounding since the invention and implementation of molded sail technology in the early 1990s. Before that time, although fibers and fabrics had developed to a point where laminated sails in particular were light, strong, and held their shape extremely well, the process of orienting panels around a load catenary was still somewhat unwieldy. The reason for this was that in order to take advantage of the low-stretch properties of today's exotic yarns, the yarns had to be continuous and precisely follow the load lines in the sail. When these yarns and fibers are incorporated into rolls of fabric, however, the fibers are laid in straight lines so that the only place where their direction can be changed is at the seams between separate panels of sailcloth. The result is a series of straight lines making abrupt changes at each seam, which is both an inexact and time-consuming way to design and engineer sails. Because of the way Cuben Fiber is made it is possible to be more precise with the threads, but they still make an abrupt change between panels.

Molded sails, on the other hand, are specifically designed to allow the yarns to follow an exact, curved catenary, thereby increasing the efficiency of each individual fiber. This can be illustrated by two different plumbing elbows (Figure 5.1). The aluminium vent on the right represents the paneled sail with a curved form being made up from a number of flat sections joined together. The molded elbow on the left is a smooth compound curve without any of the sharp angles, and it represents a molded sail. This is slightly exaggerated, but the difference is striking.

What Are Molded Sails?

At their most basic, molded sails are sails created in whole sections over a curved mold rather than pieced together from panels of flat sailcloth, as is the case with cross-cut or radial sails. Molded sails are a kind of laminated sail in that they are

Smooth vent that represents a molded sail.

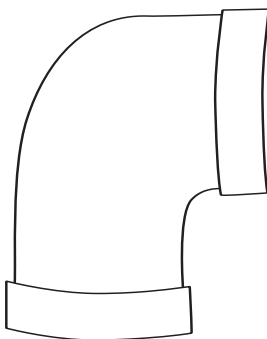

Vent pieced together from a number of flat sections like a paneled sail.

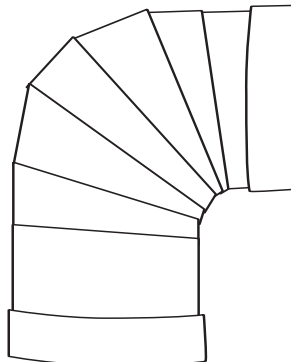

Figure 5.1

Two different plumbing elbows illustrating molded sails. The aluminium vent on the right represents the paneled sail with a curved form being made up from a number of flat sections joined together. Molded sails, on the other hand, are specifically designed to allow the yarns to follow an exact, curved catenary thereby increasing the efficiency of each individual fiber.

made up of layers of fibers, taffetas, films, and other substances. But in contrast to conventional panelled sails – either radial or cross-cut – the load-bearing yarns are laid down to follow the precise load paths that will be incurred by the sail, as opposed to straight lines in the form of a weave or scrim. Note that while in the case of North Sails' now famous 3DL process where the entire sail is made in one piece on a single mold, there are other companies that build their sails in separate sections that are then joined together to produce the final product. North, however, is the only company that can claim that their sails are truly molded. To illustrate this point, if you cut out a section of a North 3DL sail you will not be able to lay it flat. Every square inch of the sail has some molded shape to it. While the other sailmakers will argue that their sails are also molded, in fact what they are referring to are the computer programs they use that design the shape and engineering of the sail as if the sail was molded, but in fact shape is added through more conventional means, i.e., at each seam. The basic idea, however, of having load-bearing yarns or fibers follow an exact catenary remains the same. Despite the gee-whiz nature of the 3DL process, the other techniques are also worth a close look. In fact, they have plenty of advantages and backers among racing and cruising sailors alike.

An Uncertain Beginning

The technology that forms the basis of molded sails was first developed and patented by Peter Conrad, head of Sobstad Sailmakers, using a process he called Airframe. This concept, according to a legal brief drafted to defend it against patent infringements, “employed the principal of addressing the catenary-shaped load patterns in the sail by using vertical and transverse straps in close configuration where heavy loads were located.” Conrad was certainly a visionary and his technique made the most of modern technology and the latest fibers to build sails that were substantially better than their panelled counterparts. Conrad named his creation, appropriately, Genesis.

Unfortunately, the good news for sailors was soon overshadowed by a lawsuit that developed when arch competitor North Sails created its own sail-molding system in apparent violation of the Sobstad patent. The lawsuit, initiated by Sobstad, dragged through the courts for years before it was finally settled in Sobstad's favor. At times it threatened to shut down one of North's most lucrative facilities, the plant in Minden, Nevada, where molded sails are manufactured. Fortunately, cooler heads prevailed and North effectively ended up buying the patents from Sobstad, and Conrad, once a starving sailmaker, walked away a man of means.

While personal attacks and lawsuits are never good for any industry, the level of discourse did emphasize the importance of the new technology. And today, a number of sailmakers are following Sobstad's lead, including UK Sailmakers, which manufactures its own line of molded sails called Tape Drive under license from Sobstad, and Doyle, whose molded D4 sails are also said to infringe upon the patent, but which manufactures its sails in Australia where Sobstad does not have any jurisdiction. The upshot, now that the lawyers have been paid, is an entirely new way of looking at fibers, film, and adhesive, and the way in which they are combined to make sails.

Genesis

Sobstad first marketed Airframe sails in 1985, and the sails were used to win the America's Cup in 1987. Those early sails were a far cry from the sophisticated, highly engineered products that are now being manufactured, but they were a breakthrough for their time. The problems associated with paneled sails, namely bias stretch and hard angles in the catenary path were overcome by the Genesis method, which orientated individual yarns directly along specific load paths. The process starts by creating complex stress maps that analyze the various loads in sails and then reproduces the resulting two-dimensional stress map as a three-dimensional sail.

Strictly speaking, Genesis sails are not created on a mold, but manufactured in large panels, which are then pieced together to create the finished sail. In fact, in the case of Genesis sails, the seams where the panels come together are used to create the shape of the sail just as broadseaming is employed in panelled sails. Still, any sail that is designed and built using a three-dimensional design program can be referred to as a molded sail, and is certainly considered to be such by the U.S. court system. As part of its process, Sobstad has developed an interesting seam construction that allows two panels to be joined together without the need for sewing. This is important since in contrast to panelled sails where the various scrim and weaves provide plenty of yarns for the stitches to bite into, the Genesis panels have fewer yarns and the result is a seam that is much harder to sew. During the assembly process the Genesis seam is heat-sealed at 120 degrees Fahrenheit, while pressures on the order of 25 pounds per square inch are brought to bear on the seam. This heat, combined with pressure and the latest epoxy adhesives, results in a seam that does not need stitching, yet is still extremely strong (Figure 5.2).

As is the case with laminated fabrics, molded sails would not be possible without the sophisticated adhesives that have been developed in recent years. And it's important to remember that a large part of the success of the laminating process stems not only from the adhesive, but also from the amount of pressure that is applied to the surfaces being laminated. When rolls of sailcloth are laminated, for example, the pressure is exerted over a relatively narrow surface area. As soon as the surface area to be laminated is increased, say on a large mold, it is not that

Figure 5.2

Cross-section showing the Genesis seam, which uses heat, pressure, and adhesives to create an extremely strong seam that does not need stitching.

The Genesis seam, heat sealed at 120 degrees Fahrenheit at 25 pounds per square inch pressure for maximum strength.

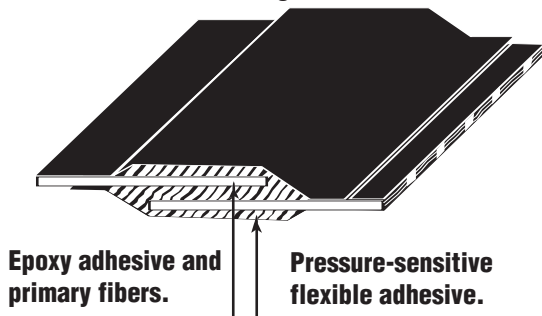

A typical sewn seam.

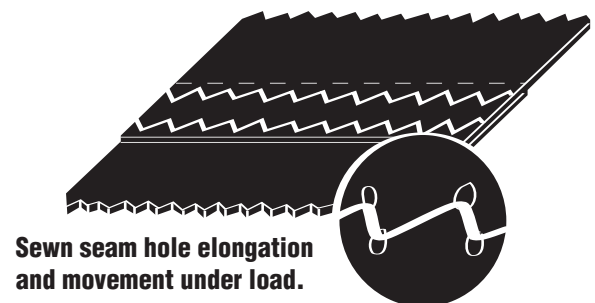

easy to get the intense pressure needed for a secure bond and more reliance is placed on the adhesive. In fact, there is an ongoing debate among sailmakers who produce paneled sails versus those that produce sails on a mold. The paneled sailmakers claim that their sails are actually lighter than molded sails because they are able to bring more pressure to bear on the fabric and therefore use less adhesive. It's an interesting debate that likely has no resolution since sails are complex pieces of engineering with too many variables to compare one technique directly against the other. It does, however, give the salesmen some interesting material for bringing in customers, and the difference in weight, if indeed there is one, will likely diminish as the technique for molding sails becomes more sophisticated.

In terms of the specific production process, the construction of Genesis sails begins with the application of thread to a film substrate, which is accomplished by a thread-laying machine that is programmed with each sail's design information. The machine plots precisely the right density and type of yarn to create what Sobstad calls the "primary carrier film." Once this is done a second layer of fiber on film is created with the yarns orientated to accept all the secondary loads to which the sail might be subjected. Then the two layers are bonded together to produce a strong panel ready for shaping and joining with the rest of the panels to finish the sail. As noted above, the individual yarns do not run the full length of the sail, since they are severed at each seam. But the design program lays them onto the film so that the seams from different panels will meet head-on creating a "virtually" continuous fiber running from head to clew. With no seam slippage and a myriad of yarns precisely oriented to accept the loads, the result is a sail designed to hold its shape once the forces of the wind come into play.

It's also important to note that with this kind of construction there is less need for the corner reinforcement usually found on paneled sails since the individual yarns radiating from the corners along the load paths efficiently take up the extra burden placed on the corners of the sail. On some Genesis sails I have

3DL sails have become a common sight on the racecourse since North Sails geared up their manufacturing facility.



The 3DL Story

In 1990 two back-room engineers working for North Sails saw the future of sailmaking from an entirely different perspective. Swiss-born sailor J.P. Baudet and his friend Luc Dubois brought the idea of molded sails to North and were given free reign to create what seemed revolutionary. The idea of molded sails had been discussed for a number of years, but talking about it and doing it are two different things. Working out of an office at North's headquarters in Milford, Connecticut, Baudet created a wooden mold in the shape of a J/24 headsail, and with painstaking precision glued Kevlar yarns under tension to a sheet of Mylar that was draped on top. In order to do so he had to hang suspended above the mold like some high-tech Peter Pan and create the sail piece by piece.

Once the initial threads were laid down with each thread following a specific load path, a second piece of Mylar was placed on top and the sail was then vacuum bagged and heat applied to set off the glue. The result, its builders claimed, was a sail that was 33 percent lighter than a conventional panelled sail and held its shape through a wider range of wind conditions. It was also remarkably smooth and surprisingly rugged.

While this J/24 headsail was certainly a breakthrough, there was no way that larger sails could be similarly manufactured in any remotely cost-effective way, at least until a more flexible mold platform could be both designed and built. Since it was sailors who first brought the idea to engineers, it was not surprising to see that the system for changing the shape of the mold was done by a series of pulleys and cleats, not unlike those found on boats. With this system in place, the mold platform could be manipulated to create different shapes for different sails, and an entirely new way of making sails was created.

These days the mold platform is precisely controlled by computer-driven hydraulic rams and technological leaps have taken place in the way fibers are applied and sails vacuum bagged. Still, it was from those simple beginnings that this new technology was begun.

sailed with this area was vulnerable to delamination because of the number of fibers laying on top of each other. But this is an issue that over time has been addressed and improved upon.

3DL

From the beginning it seemed obvious, even to a casual observer, that North's 3DL technology was strikingly similar to the Genesis process, and that a lawsuit might ensue; although there are also plenty of differences, which helped to give the lawyers plenty to talk about. We will spend more time on 3DL than on the other molded sail techniques, not because it is necessarily a better way to make sails, but because North has come to dominate the racing market since it started making and marketing 3DL sails. Bear in mind, however, that despite the hype, it is not the only way to make a top-of-the line racing or cruising sail.



Looking under the 3DL mold platform where a series of computer-operated rams manipulate the shape of the mold to suit the design of the sail.

3DL actually stands for “three-dimensional laminate” and has become synonymous with cutting-edge sailmaking. One of the biggest advances that 3DL technology brought to the industry was not only a new look for sails, but the elimination of an entire step in the manufacturing process, since the 3DL process manufactures both the fabric and the entire sail at the same time and in one piece. It’s this advance, as much as any of the performance gains, that has rocked the sailmaking world.

3DL sails are currently being manufactured in a modern facility in Minden, Nevada, where the low humidity in the air is critical for a successful lamination process. There are eight molds, the largest of which can build a headsail for an 80-foot maxi-

boat in a single piece. While the early molding platforms were quite rudimentary, these newest molds are sophisticated pieces of equipment with precise surfaces being created by a series of hydraulic rams manipulating a flexible base. In 2002 North introduced a new “Rotary Mold” that can manufacture sails for smaller boats on a revolving drum rather than a regular mold.

Building a 3DL Sail

Step 1 – Sail Design

The 3DL building process begins with a three-dimensional computer-aided design or CAD/CAE that, because it is created on a mold as a true molded shape, ends up with the “flying shape” being quite close to the molded shape. Instead of cutting panels and sewing them together to create the sail, however, the sail design is sent to a computer that manipulates the mold platform, which then assumes the designed shape. Depending upon the intricacy and size of the sail design, it can take anywhere from one to 15 minutes for the platform to reach the desired shape.

A worker suspended in a harness keeps an eye on the armature that applies the threads to the surface of the sail.

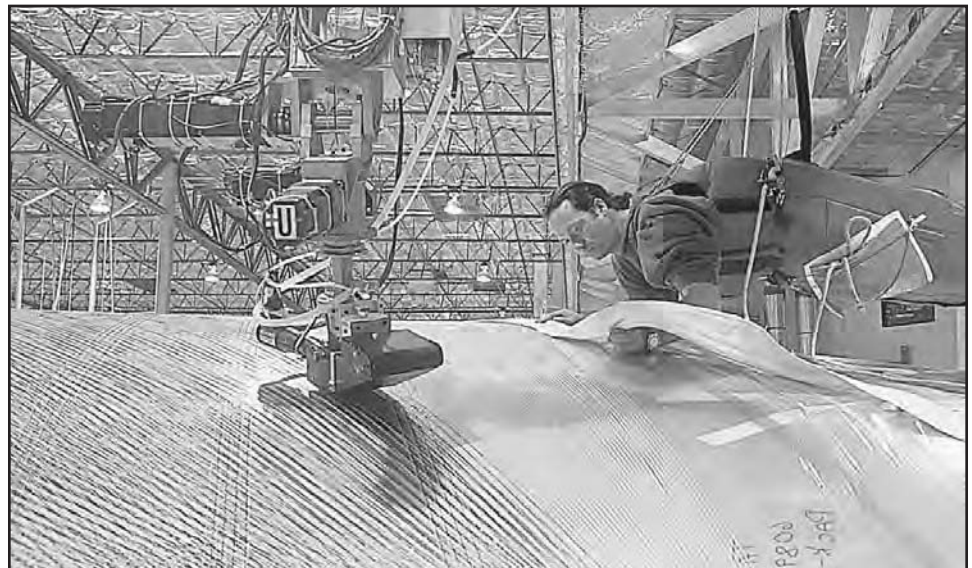

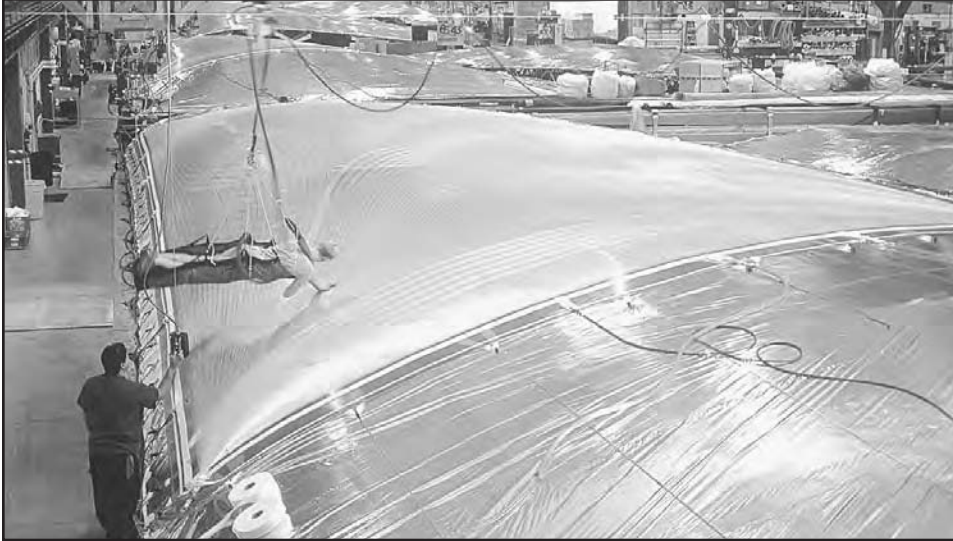

The 3DL manufacturing facility in Minden, Nevada, showing a number of molds with sails of different sizes being manufactured.

Step 2 – Laying Fibers

A Mylar film is then draped over the mold and placed under tension, after which an armature suspended from a moving overhead gantry applies the individual fibers onto the Mylar film in a manner dictated by the sail engineers. The fibers are laid onto the surface under uniform tension to precisely match the anticipated load paths in a way similar to that of a Genesis sail, i.e., a two-dimensional stress map slowly becomes a three-dimensional sail. As the yarns are laid down they are coated with an adhesive that bonds the fibers to the substrate. While these primary load-bearing yarns are being added to the sail, a worker suspended in a harness follows the gantry, closely inspecting the process and making sure that each individual fiber is secured to the base.

Step 3 – Adding a Scrim

Once all the yarns are laid down, a second film is placed over the top of the Mylar and fiber base. This second film contains a light scrim that provides overall structure to the finished sail and can either be of the same fiber as the principal yarns or a different fiber. Once this layer is in place and under tension, a large vacuum bag is placed over the entire sail and used to compress the laminate.

Step 4 – Heating and Curing

The gantry head is then removed and replaced with a radiating heat element that cures the pressurized laminate. Workers keep a watchful eye on this process making sure that the heating element does not overheat any area of the sail. They will even use a damp mop to cool areas that become too warm. The sail is then left in the bag to cure so that the desired sail shape can be fixed.

Step 5 – Finishing

Once the laminate has cured, the sail is finished in much the same way as a conventional panelled sail. Corner reinforcements, bolt ropes, batten pockets and so forth are sewn to the sail, and the edges are trimmed with tapes. Any hardware is attached to the sail, which is then given a final check and sent to the customer.

Emma Richards sailed Pindar single-handed around the world using North's 3DL Marathon sail.



Continuing Improvements to 3DL

Like most new technologies, the first 3DL sails had some unanticipated glitches, including problems with laminate adhesion and durability. These issues, however, have been rectified over the years and the latest generation of 3DL sails are as close to perfect in terms of construction quality as they are likely to become. Big gains have also been made in terms of understanding the relationship between actual load paths and the fibers laid along those paths to reduce or eliminate stretch. Since sail shape development and stretch elimination is an ongoing process, it's likely that the fiber patterns will continue to evolve. For example, where the original fibers ran from corner to corner in arcs, the fibers on the latest layouts run from each corner to the opposing leech, luff or foot. How the next generation of sails will look is anyone's guess.

Moisture Absorption

One of the first big improvements in terms of 3DL construction was the realization that humidity had an effect on the laminating process. Any kind of moisture that was trapped in the laminate turned to steam when heat was applied to cure the sail, and this weakened the bond between layers. To reduce moisture, environmental controls were implemented that monitored the humidity and kept it from being absorbed. This applied to both the working environment and to the yarns themselves. Today, the yarn spools are heat-cured in drying ovens at 140 degrees Fahrenheit for five days before being used. They are then transferred to the gantry in special hermetically controlled carts and dispensed through hermetically controlled chambers built into the fiber head. By taking extraordinary steps to eliminate moisture from the laminate, the bonding process has been dramatically improved.

Adhesive Technology

The amount and quality of the adhesive, and the amount of pressure that can be applied to the sail's surface all affect the weight and lamination of the finished product. New adhesives have been developed that combine a flexible sheet of adhesive with a more rigid one. When heated these combine to provide an immensely strong bond that relies more on the properties of the adhesive and less on pressure.

Head Pressure

One of the problems encountered in early 3DL sails was similar to the crimp found on woven fabrics. The head that dispenses the fiber onto the Mylar surface was bearing down with roughly 28 pounds of pressure, and this excessive pressure was forcing the yarns to form sharp edges where each yarn encountered another in its path, basically creating another form of crimp. Once a load came on the sail the crimp would attempt to straighten out, causing stretch and distorting the carefully shaped sail. As a result, the newest heads apply very little pressure as they lay the yarns down, and the threads “float” over each other without any angles or crimp.

Adding Durability

Just as film-on-film fabrics were first used exclusively by cutting-edge racing sailors, early 3DL sails were once the purview of grand prix racers alone. Over time, however, North Sails has looked to expand its market to include cruising sailors by adding durability to its molded sails. The company now adds light taffetas to the outsides of molded sails, which do the same thing as they do on regular sailcloth: protect the fragile load-bearing yarns from chafe and UV, and thus add overall life to the sail. Of course, they also add weight so it’s again a matter of trade-offs. North Sails calls this product line with taffetas its Marathon Series, and the sails have been used successfully in rugged offshore ocean races like the Volvo Ocean Race, the Around Alone, and the Vendée Globe.

As these advances in 3DL technology aimed specifically at the cruising sailor take hold, the broad acceptance of high-tech molded sails among this heretofore reasonably low-tech marketplace will be inevitable. How much of an inroad they will make, only time will tell. But judging by the marketing dollars being spent to introduce this technology to cruisers it’s clear North Sails believes it has a perfect match. The same can be said for small boat sails. Until now it was not cost effective to tie up the mold making a small sail; bigger sails bring bigger profits. But

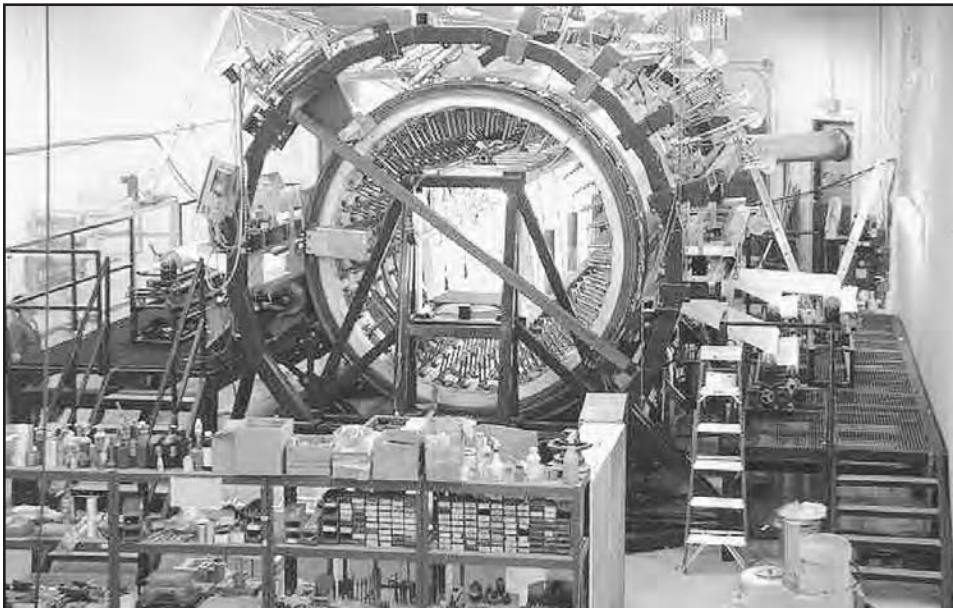

North’s rotary mold is used for making 3DL sails for boats up to 30 feet. This is a cost-effective way of making high-tech sails for smaller boats.

Tape Drive sails are still a dominant force on the racecourse and some of the latest designs display cutting-edge technology.



North's Rotary Mold technology, basically a revolving drum with a surface that can be adjusted by approximately 1,000 computer-controlled pistons, is changing this as well. In this technique, the pistons radiate out from the axis of the drum to manipulate the shape while computer-controlled yarn heads lay a precise matrix of structural yarn onto a Mylar film with a coating of adhesive on the drum's surface. A second layer of Mylar is then added and the laminate is cured with forced hot air. This relatively simple method of making sails for boats up to 30 feet is a cost-effective way of introducing a high-end technology to a traditionally less technically advanced market.

3DL and indeed all forms of molded sails will doubtless continue to evolve and improve. North has the resources and clout on the racecourse to push this technology as far as it's likely to go. Still, while it has both created new markets and refined old ones, other sailmakers are still plugging along with their own proven technologies.

Tape Drive

Tape Drive, for example, has been around since the beginnings of molded sails and is the exclusive domain of UK Sailmakers. In fact, UK Sailmakers was one of the first sailmakers to acknowledge the Airframe patent, immediately applying for a licence to build sails using this new technology. Instead of laying thousands of individual fibers along load paths, however, Tape Drive uses high-strength tapes to accept the loads in the sail in a two-step process in which a base fabric or membrane defines the sail's three-dimensional shape and the tapes lend structural strength. Both the tapes and the base membrane can be made from any available fiber, and the ability to combine fibers in a sail allows the sail designer to make the most of each fiber's best properties.

The tapes, some with breaking strengths of up to 1,900 pounds, radiate from the corners of the sail with a heavier concentration in the high-load areas. The tapes are glued to the membrane, turning the entire structure into a single com-

ponent without any of the problems associated with seams. In Tape Drive sails the base membrane resists stretch uniformly throughout the sail so that there is no uneven distortion or shrinkage in any particular region. The result is a web of fibers that makes the sail resistant to tearing. If the sail does rip, the tear travels as far as the nearest tape where it is quickly arrested.

Just as with 3DL and Genesis, UK Sailmakers is constantly refining its product. As more is learned about the strength and stretch resistance of the tapes, more can be done to place them on the sail surface where they can be the most effective. With such an innovative way of making sails, it's likely this technology will be around for a long time.

D4

With the obvious success of molded sails, be they Genesis, 3DL, or Tape Drive, Doyle Sailmakers, headquartered in Marblehead, Massachusetts, had to find a way to get into the market without stepping on the Airframe patent. It seemed that the easiest and most expeditious way was to manufacture the sails out of the jurisdiction of the Airframe patent, and with a modern loft in Australia the company had a ready-made solution. This, however, is only a small fraction of the story. In fact D4 offers a very successful process that builds upon Genesis and improves



Doyle's D4 sails on board Titan. The D4 technology is starting to rival 3DL and Tape Drive.

upon some areas of 3DL. Specifically D4, which makes up its sails from panels similar to the Genesis model, uses less adhesive for laminate bonding because of the increased pressure that it applies on the laminate surfaces. Again, because there are so many other variables in a sail, it's hard to substantiate some of the claims surrounding D4, but it makes sense that you can apply more pressure to a small flat laminate than you can to a large curved one.

In terms of the overall construction process, the D4 sail designer divides the sail into sections similar to those for a paneled sail, in which horizontal seams form a dividing line. For example, a mainsail with five battens would typically be built from six sections, with each section manufactured separately. Actual construction then begins by laying out large flat sections of polyester films coated with a UV-resistant resin upon which a machine similar to the one used to lay yarns on a 3DL sail places fibers according to a computer-generated design. These yarns are then coated with adhesive and bonded to the film, an additional lightweight scrim is laid over the substrate along with a second film, and this sandwich of film, adhesive and fibers is laminated together using extreme pressure and heat. Afterward, when the new laminate has had a chance to cure, these flat sections are scribed using a large plotter that shapes the luff, leech, and foot curves so that once the sections are joined together, the finished sail will assume a designed shape with the edges already drawn. The various sections are then glued together and the sail is finished the same way as a paneled sail – with corner reinforcements, bolt ropes, batten pockets, and other hardware – and the edges are trimmed with tapes.

Case Study—Transatlantic Race

Two sailors are planning to compete in the Cape Town to Rio Race aboard different boats: one a 60-foot IMS design with a reasonable budget and a strong will to win; the other a 60-foot performance cruising boat that is planning to continue on after the race and sail to the Caribbean. The owner of the cruising boat wants his sails to be good for the race as well as for cruising afterward.

For the owner of 60-foot IMS boat there are a number of options:

- 3DL Marathon series.
- Regular paneled sails.
- D4 inventory.
- Tape Drive.
- Genesis.

The important considerations are:

- Low stretch – use the latest technology.
- Durability – offshore racing is harder on sails than inshore.
- UV resistance – the boat will be racing through the Tropics.
- Engineering – the fact that this is a downwind race.

The fabric needs to be a high-performance type such as Kevlar with a film-on-film construction, and if regular paneled sails are chosen there needs to be an X-ply for off threadline stability. The X-ply refers to diagonal yarns that can be added to a laminate. With a scrim insert there will be no crimp, and therefore no

initial stretch. All of the sailmaking options listed will accomplish this. Taffetas must be added to help with durability, since they are important for abrasion resistance. Long offshore races subject sails to a lot of wear and tear and adding a layer of woven fabric, even a light one, to the outside of the fabric will protect and extend the life of the sail. In addition to protecting the inner layers of the fabric, the taffetas will serve two additional purposes: They will add a small amount of off-threadline stretch resistance, and they will also serve to dampen the flogging motion of the sails. UV resistance must also play a big part because the sails will be subjected to a lot of sunlight. There are two things that can be done to protect the fragile fibers. First, the adhesive that bonds the layers of fabric can be treated with a UV inhibitor, which alone will probably be sufficient to protect the Kevlar yarns. Then, for added durability, the polyester taffetas can also be treated with a UV inhibitor. The combination of adhesive and taffetas encapsulating the Kevlar yarns should be more than enough to ward off any sun damage.

Because the race will be mostly off the wind, it will be important to engineer the sail to accommodate loads coming out of the tack of the main. Had the race been mostly upwind there would have been very little load coming out of the tack and either a bi-radial mainsail or a molded sail that takes into account these loads would have been fine. Instead with the race being downwind, a tri-radial sail with load-bearing panels radiating from the tack of the sail, or a molded sail that takes this into account will be very important.

Had the budget not been a consideration the taffetas could have been omitted, making the sails lighter and easier to handle, but without the added protection they offer, the sails will not last as long. They would certainly go the distance of the Rio race, but the sun damage and flogging would have severely weakened the sail by the time the race is over. The other alternative could have been an inventory of Cuben Fiber sails. These are light and very durable, but the fabric for boats in the 60-foot range is relatively expensive and Cuben Fiber was therefore ruled out because of budget constraints.

For the owner of 60-foot performance cruising boat there were also a number of options, although molded sails were ruled out because there were concerns about getting the sails repaired when cruising. Beyond that the owner was given three choices for his working sails: Spectra, Pentex, or Dacron. The Spectra would cost the most – 30 percent more than Pentex and 50 percent more than Dacron – but would last the longest. Remember that if you measure the life of a sail by how long it holds its shape, not just how long it's able to be used, investing in fabric up front is a reasonable consideration. Ultimately, the owner chose Dacron for aesthetic reasons as well as price and durability. Dacron fabric is the type used to build cross-cut sails and the owner of the boat had a preference for the cross-cut look rather than the more modern tri-radial look. Because the Rio race was primarily a downwind race, the loads on the sails would be greatly reduced and therefore Dacron became a viable option. Had the race been mostly upwind, there would have been more need for a low-stretch, high-performance fabric like Spectra or Pentex, since both Spectra and Pentex have low initial

“Long offshore races subject sails to a lot of wear and tear and adding a layer of woven fabric, even a light one, to the outside of the fabric will protect and extend the life of the sail.”

stretch and no crimp, and a medium displacement 60-foot cruising boat is well into the range where a high-performance fabric would be a better investment. Still, in this case weight aloft and low stretch were not the principal factors. Aesthetics and ease of repair were, and therefore Dacron was a good choice.

In the end, the mainsail and working headsails were built from a balanced Dacron with a second ply up the leech of fill-orientated Dacron. The balanced Dacron gave the sails overall stability, which was good especially since the boat would be sailing downwind. The fill-oriented second ply gave the sails the necessary strength in the high-load areas and allowed the base fabric to be a bit lighter. The overall weight of the sails was about 20 percent more than if the sails had been made from Spectra or Pentex, but the trade-off was worthwhile given the plusses of Dacron.

Other Advantages of Molded Sails

In addition to weight savings, molded sails have another big advantage in that the sails are more pliable. With yarns concentrated only where they are needed, the sails have an easy feel to them, and when flaked and bagged they take up much less room on board than their panelled counterparts. Up until molded sails came onto the scene, sail designers concentrated their efforts on sail shape, and this was where the biggest gains were made. Now with precise yarn placement designers are spending a lot of time and money developing increasingly accurate stress-analysis programs. Similar gains can be made by reducing stretch as were made by enhancing shape.

By eliminating the fabric makers from the process, sail designers creating molded sails have more control over the finished product. Fabric makers will say that this is not an advantage, that their expertise is sailcloth engineering and sail-makers should stick to making sails in order to make the best use of the materials at hand. They may have a point. They have certainly been doing it for a long time and understand the nuances of fibers and film. On the other hand, molded sails are here to stay, and they will only improve on their already near-perfect shape and engineering.

At some point you may have to decide if the latest technologies are for you. In Chapter 1 we discussed the fact that you need to ask yourself some hard questions. This is when you will have to ask those questions. There is no doubt that 3DL and the other molding methods are very interesting ways to engineer and manufacture sails, but they are not the only way to go in terms of buying new sails. Among other things, for now at least they are quite a bit more expensive than regular paneled sails—about 15 to 20 percent more for 3DL and 10 to 15 percent more for the others. Maybe you are the type of person who just has to have the latest technology and that alone is reason enough to buy the top of the line. On the other hand bear in mind that paneled sails have advanced to the point where they are rugged, durable, light, and high performing, so they may well do a more than adequate job for you. Ask yourself what it is you want, whether the added expense can be justified, and you will come up with the answer that is right for you and your boat.

“ . . . molded sails are here to stay, and they will only improve on their already near-perfect shape and engineering.”

Chapter 6

WHERE ART AND SCIENCE MEET

A Look at the Sailmaking Process

The basic tools of sailmaking are no longer the stuff of charm and tradition. Where bolts of sailcloth, spools of wax thread, and hides of tanned leather once filled corners of sail lofts, and old men with character lines in their faces and stories to tell worked their craft, there are now talented young men and women operating high-powered computers. Gone too are the large open wooden floors marked with awl holes and chalk marks with patterns drawn on the varnish and templates hanging on nearby hooks. Instead, there are laser cutters and plotting machines whirring quietly off to the side, while efficient workers assemble sails on lofting tables. I fell in love with the old sail lofts and wonder if I would have been as intrigued with the business of sails had I come upon it in recent years. Certainly something is missing, although then again nothing ever remains the same, and a loss for some has been a gain for others. Sailmaking has evolved and has made extraordinary gains since computers became readily available. Still, because of the nature of sailing and the infinite variety in the forces encountered out on the water, some art remains in the process. At least I choose to think so.

Despite the advances and no matter what the sail, the sailmaker's job remains the same: to take flat fabric and turn it into a three-dimensional aerodynamic foil that will hold its shape through a variety of wind conditions. Even with miracle fibers and computer programs this is no easy task given the number of variables. Fabrics that stretch, rigs that bend, and sailors with differing opinions of what looks right all make the job more complicated. It was only once the stretch characteristics of fabrics became predictable that sailmakers were able to build upon empirical data gained by experience. Up to that point they had to start anew with each new bolt of sailcloth since they had no idea how the fabric might stretch and how their design should compensate for this distortion. It was only after this variable was eliminated that they could begin to build upon the design information they already had. If a new luff curve or chord depth ratio proved faster, for example, that information could be repeated and improved upon. This incremental improvement eventually led to sails that were lighter, more efficient, more durable, and easier to use. But it took a long time, at least by modern standards, and could often be prohibitively expensive for all but the wealthiest sailors. In fact, a benefit of modern technology is that, factoring in inflation, sails are actually cheaper today than they were a few decades ago, and they last longer.

The Quantum sail loft in Cape Town, South Africa, is a modern, high-tech facility that turns out quality sails for export around the world.



The Design Process—Turning Theory and Fabric Into Flying Shapes

Each sail goes through a number of design steps before construction can begin. Some steps, like sail geometry or the basic shape of the sails, are reasonably simple while others, like computing stress/strain pictorials, require much more thought and deliberation. Ultimately, the shape of each sail will be drawn from a database of known sail designs and manipulated until the designer is satisfied that the sail he is creating for your boat is perfect for your purposes. Before we look at the various steps involved in sail design, we need to first look at some of the design features the sail designer is aiming to achieve. These features are important to the overall success of the sail and are basic to all sail designs.

Chord Depth or Sail Draft

This is probably the single most important feature of any sail. The chord depth, also called the camber or draft, is determined by running an imaginary line or “chord” from the luff of a sail to the leech (Figure 6.1), and then measuring the distance from this line to the deepest part of the sail. The “chord-depth ratio,” often expressed as a percentage, refers to the ratio between the length of the chord and the depth of the sail. Because sails taper toward the head, it is important for the draft of the sail to be expressed in terms of a ratio rather than a measurement. A depth of 18 inches in the body of the sail could be seven inches toward the head and still have the same chord-depth ratio. Note that chord depth can be adjusted by the way you set your sails and that there is no one chord depth that is perfect for all conditions. Rather there is a chord depth that is right for a *given set of conditions* taking into account wind speed, wind direction, wave heights, the kind of boat you are sailing, and so on. One of the main goals of sail trim is to match the chord depth with the conditions to provide an optimal performance. This will be covered in more detail in the chapter on sail trim.

Figure 6.1

The chord depth is determined by running an imaginary line or “chord” from the luff of a sail to the leech and then measuring the distance from this line to the deepest part of the sail.

CHORD DEPTH

SEPARATION

If the sail is too deep, the fast-flowing air will not be able to remain attached after the deepest part of the sail, and it will separate.

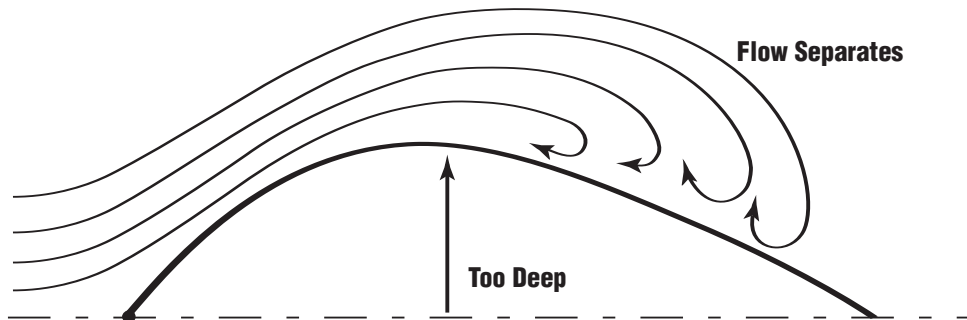

Different chord depths are important for different wind conditions in order to keep the flow of the wind attached to the sail. As a general rule of thumb, full sails (read lower chord-depth ratios) work better in light winds, and flatter sails (read higher chord-depth ratios) work better in medium to heavy winds. Using a full sail in a lot of wind will cause the fast-flowing air to separate from the sail (Figure 6.2). Flat sails can also work well in extremely light winds since they make it easier for the air to remain attached to the sail. If you try to make the sail too full there is simply not enough wind for the flow to even get around the corner, let alone to the leech.

The chart below gives you some idea of optimum chord-depth ratios for both mainsails and headsails. These are general estimates and should not be cast in stone. There are so many variables among boats of different designs that the numbers need to be manipulated to suit the conditions, but as a jumping-off point, these wind strengths and numbers are a good start.

Figure 6.2.

With a chord-depth ratio too high, the flow of the wind cannot remain attached to the sail.

Apparent Wind in Knots	Headsail Chord Depth
0-2	15-16 percent
3-12	18-19 percent
10-18	16-17 percent
16-23	15-16 percent
20-26	14-15 percent
24 +	12-13 percent
Apparent Wind in Knots	Mainsail Chord Depth
3-6	15-16 percent
6-12	14 -15 percent
12-18	12-13 percent
18-24	11 percent
24	10 percent

* Courtesy of North Sails

Figure 6.3

When the wind blows across a body of water the surface friction slows the molecules closest to the surface, which in turn have an effect on those molecules closest to them.

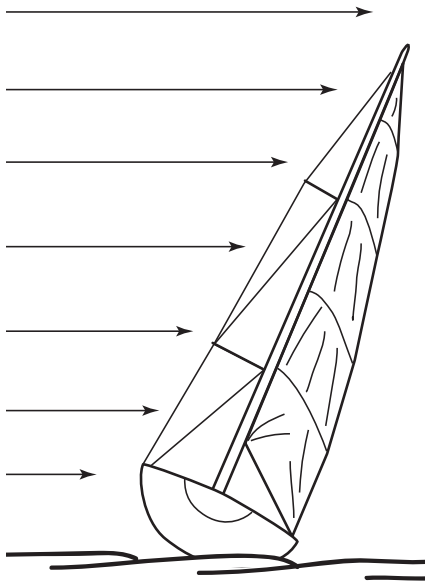

Wind speed aloft is as much as 50% more than wind at sea level.

True Wind and Apparent Wind

True wind is the wind that you feel when you are standing still. Apparent wind occurs when you start to move. An obvious example of this would be the wind you feel in a moving car. On a calm day if you are driving at a speed of 50 mph then you are also experiencing an apparent wind of 50 mph. If, on the other hand, there is a breeze, then the apparent wind can be either more or less than the true wind depending on the direction in which you are travelling. If you are moving away from the true wind, the apparent wind decreases since your movement cancels out some of its effect. Conversely, if you are moving toward the wind, the apparent wind increases. To use a specific example out on the water, let's say there is a 15-knot breeze and you are sailing dead downwind at a speed of 5 knots. The apparent wind, i.e., the wind that you experience on board, will be 10 knots.

The second element in the chord-depth equation is the location of the maximum depth relative to the chord: In other words how far back from the luff is the point of maximum depth? This amount is also usually expressed as a percentage and is important because it is crucial in determining the overall aerodynamic shape of the sail. In headsails, the maximum chord depth should be roughly 35 to 38 percent aft from the luff, while for mainsails the maximum chord depth should be around 45 to 50 percent aft. The chapter on sail trim will be more specific on where to place this point of maximum draft as well as chord-depth ratios.

Twist

Any surface, no matter how smooth, presents an area of friction to the air passing by it, and water is no exception. When wind blows across a body of water the surface friction slows the speed of the air molecules closest to the surface leaving those particles higher off the water travelling at a higher velocity. Some scientists believe that over a height of 60 feet there can be as much as a 50-percent gain in wind speed (Figure 6.3). With this increase in speed comes a change in apparent wind angle, i.e., the angle of the wind relative to the orientation of the boat as it moves through the water (Figure 6.4). We will learn more about apparent wind speed and its effect on apparent wind angles in the chapter about sail trim, but for now this is a brief description of the difference between the two.

Figure 6.4

A change in the wind speed will change the apparent wind angle – the angle of the wind relative to the orientation of the boat as it moves through the water.

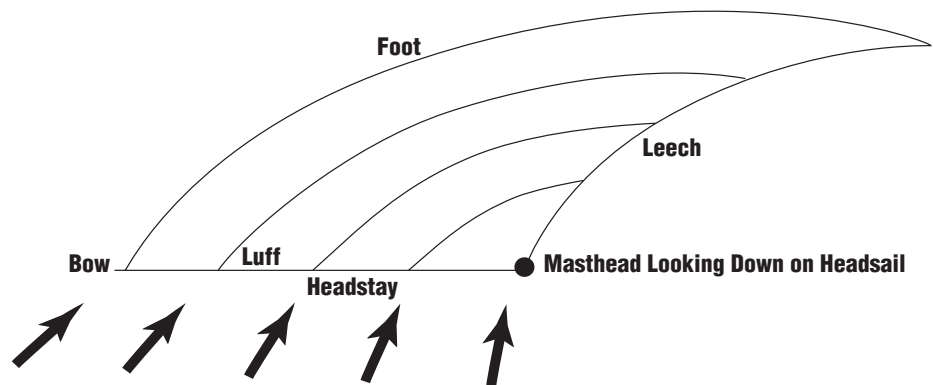

Apparent wind is pulled aft toward the top of the mast as true wind increases.

True Wind Speed at 10 knots

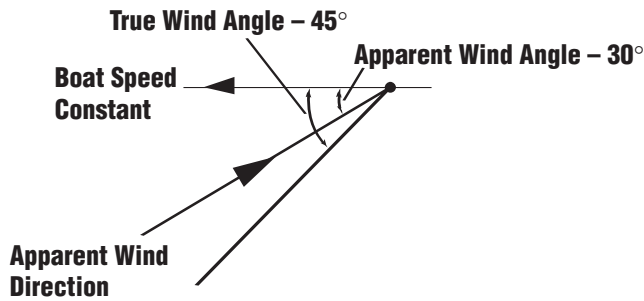

True Wind Speed at 20 knots

More true wind pulls apparent wind aft, increasing apparent wind angle.

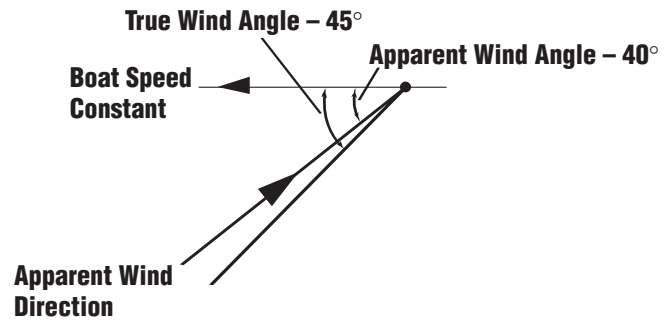

Another element of apparent wind is its angle relative to both a boat and the angle at which it is sailing since any change in wind or boat speed will have an effect on the angle at which the wind comes into contact with the sails. For example, when there is an increase in true wind speed, the apparent wind angle will be pulled more toward the direction of the true wind (Figure 6.5). In other words, the apparent wind angle will increase.

As you get higher off the water there will be more wind and therefore a larger wind angle so that, for example, when the bottom third of your sails is sailing hard on the wind the top third may be sailing on a close reach. If you want the whole plane of the sail to be efficient you need to turn or “twist” the plane higher in the sail to account for the increase in wind speed and change in wind angle. This is the essence of twist and the reason why sails need to be designed accordingly.

This twisting of the wind should not be confused with wind shear, a sudden change in wind speed or direction that occurs naturally in some weather systems. Twist will always occur; shear might sometimes occur, and when it does you will need to trim your sails accordingly. Note that a natural twist occurs when a sail is sheeted on tight, whether or not it is part of the original design. This is because the part of the sail closest to the point of attachment, i.e., the sheet, will be more directly influenced by the sheet than that part of the sail that is further up the leech. In other words, the higher you go, the less influence there will be on the sail and the sail will twist open of its own accord.

Vertical Distribution of Depth

As alluded to earlier, a sail designer needs to think about how exactly the camber is to be distributed throughout the sail. At first glance one would assume that the camber is evenly distributed from head to foot, but that is not the case. As a general rule, sails have more depth at the head and less at the foot. In order to fully understand this design requirement, we need to take a closer look at yet another significant detail that comes into play when a boat is sailing, a phenomenon called “induced drag”

Figure 6.5

When there is an increase in true wind speed, the apparent wind angle will increase.

The wind attempts to get from the high pressure (windward side) to the low pressure (leeward side) by going over the top of the sail and under the boom causing induced drag.

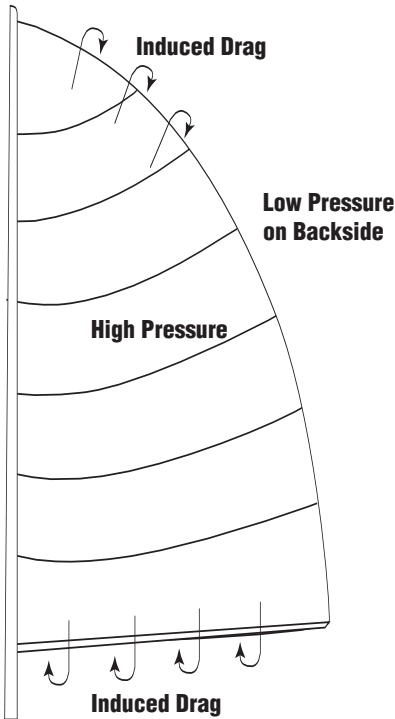

Figure 6.6

The air flowing up and over and down and under combines with the natural flow to create spinning pockets of air called vortices, which detract from the amount of energy available to move the boat forward.

Induced Drag

In terms of the physics of how a boat sails, there are a number of different types of lift and drag that are fundamental to performance. Two obvious types of drag are form drag, which occurs when any object presents a surface to the movement of air, and frictional drag, which is a function of the amount of friction between any surface and the surrounding air. Race cars and airplanes, for example, are streamlined in an effort to minimize the former, and their surfaces are kept smooth in order to minimize latter. But while both of these forms of drag inhibit the free flow of air, neither comes close to slowing a boat down like induced drag. So what is induced drag and how does it relate to the vertical distribution of camber in a sail?

When a boat is sailing to windward there are two areas of differing pressure: a high-pressure area on the windward side and a low-pressure area on the leeward side. In an attempt to reduce these pressure differentials, air from the windward side pushes over the top of the sail and under the bottom of the sail to get to the area of low pressure on the leeward side (Figure 6.6). This air flowing up and over and down and under combines with the natural flow around a foil to create spinning pockets of air called vortices, which detract from the amount of energy available to move the boat forward since the vortices themselves require energy for their formation. For a more striking example, think about the induced-drag vortices that flow off the end of an airplane wing. They are so powerful that smaller planes are not allowed to take off directly behind larger aircraft for fear of the smaller plane encountering these violent vortices and crashing. That's a lot of energy, and it's the reason you will see small winglets on the end of the plane's wings. It's also the reason why, since the 1982 America's Cup when *Australia II* won with a winged keel, winglets have become critical to keel design. Swirling vortices of water require even more energy for their formation. In an ideal situation you want the wind, and in the case of the keel, the water, to flow onto and off the foils with as little disturbance as possible.

So bearing in mind induced drag let's look at the geometry of a sail. It's obvious that the bottom of a sail has the potential to provide the most lift because it has the longest chord and is the largest part of the sail. But it is also closest to the foot of the sail, i.e., the area of the most induced drag. Fortunately, sail designers have figured out that by keeping the lower third of a sail flatter they may sacrifice some lift, but they will also be able to reduce induced drag, which actually improves the lift-to-drag ratio. This is because flat lower sections serve to keep the wind flowing across the sail rather than allowing it to dip under the foot. The result is that the overall driving force of the sail is improved.

So if the lower third is flatter, how does the rest of the sail shape up? Ultimately it is the middle of the sail that generates the most force and gets the most attention from designers trying to create the perfect shape, since it is away from the areas of induced drag and still has a reasonable chord length. The top third of the sail, on the other hand, carries a deeper draft to compensate for the

natural twist in the apparent wind and the fact that the top of the sail is actually sailing along in a big lift, in other words it can afford to be a bit fuller than the rest of the sail. Furthermore, because the chord length is so short as the sail tapers to a point at the head, sail designers simply add depth to give the sail more power, a design feature that plays into the apparent wind situation perfectly. The problem with induced drag is also less significant because the sail is comparatively narrow at the top, so designers can design in the extra drag without the price that would have to be paid along the lower third of the sail.

To recap, sails are generally flat down low, the right shape through the middle sections, and full toward the top. It's the sail designer's job to make this transition smooth and at the right place to create a perfect sail (Figure 6.7).

Leading Edge Angle

The very front of a sail, called the leading edge, is the part of the sail that first comes into contact with the wind and therefore is vital to overall aerodynamic shape. It is here, especially with headsails, that the sail generates its power since it is the first place that the wind comes into contact with the sailplan. The obvious goal of the sail designer is to create a sail with an angle of entry that facilitates a smooth introduction of the flow of air over the sails, i.e., the front of the sail should be directly in line with the wind. But as is so often the case with sails, this is not quite as easy as it sounds and involves a number of trade-offs.

For example, if a sail has a fine entry then the boat should be able to sail closer to the wind, so why would anyone choose anything else when the basic goal of sailing to windward is to steer a course as close to the wind as possible? Actually there are a number of reasons, including the fact that the angle at which the sail starts out will have an effect on the rest of the camber of the sail (Figure 6.8), which can result in a number of unintended consequences. Take, for example, two sails with an identical chord length. If the designer wants to keep the area of maximum draft in the same place in both sails, then a sail with a fine entry will end up being flatter (higher chord-depth ratio) than one with a rounder entry (Figure 6.9 on next page). Along these same lines, if he wants to keep the chord-depth ratios the same, the sail with the fine entry will end up having the area of maximum draft further aft while the draft will be forward with

Figure 6.7

The sail designer's job is to create a perfect sail with smooth transitions in the right place – from flat down low to full toward the top.

VERTICAL DISTRIBUTION OF DEPTH

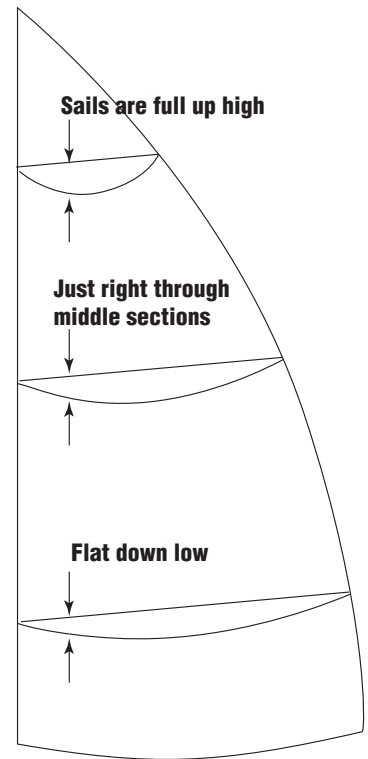
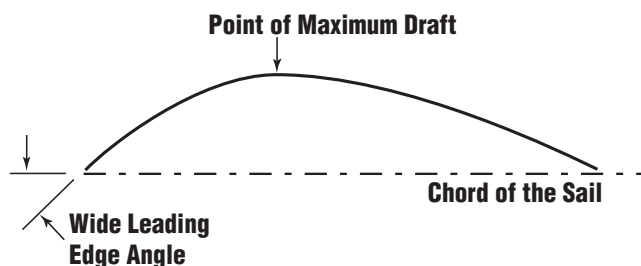

Figure 6.8

The angle at which the sail starts out will have an effect on the rest of the camber of the sail.

DRAFT FORWARD SAIL



DRAFT FORWARD SAIL

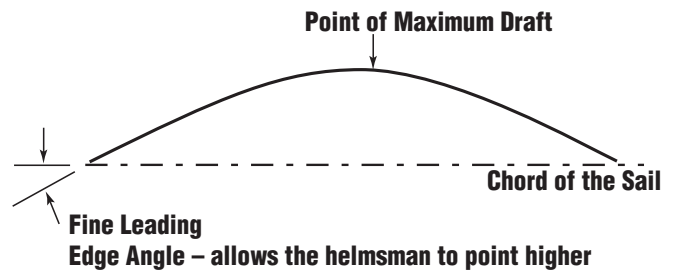

With chord depths the same, the location of maximum draft changes the leading edge angle.

Figure 6.9



Sails with a fine entry will end up flatter if the area of maximum draft is in the same place as a sail with a wide entry.

Figure 6.10

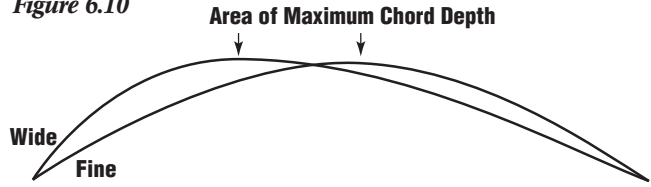

Sails with a fine entry will end up having the draft further aft than a sail with a wide entry if both sails are to have the same chord depth.

Figures 6.9 and 6.10

To keep the chord-depth ratios the same, the sail with the fine entry will end up having the area of maximum draft further aft while the draft will be forward with a rounder entry.

a rounder entry (Figure 6.10). It is at this point that sail design becomes a delicate balance of competing interests since pointing ability is a good thing, but the draft-aft sail increases drag and runs the risk of having the flow stall over the leeward side of the sail, especially toward the leech. This means it will be more difficult for the helmsman to steer the boat to the sails, since even the smallest mistakes will result in a loss of aerodynamic efficiency. A round entry, on the other hand, might not allow the boat to point as close to the wind as a fine entry, but the maximum camber will be forward, increasing lift and reducing drag with a flatter leech section. Because this sail is less likely to stall, steering does not need to be so precise, which will make life much easier for helmsman. Unfortunately, there is a bit of a dichotomy here since flat sails are generally desirable when the wind is fresh and the waves are kicking up – precisely the time when helming is the most difficult. In fact, what you really would like for these conditions is a sail with a rounded entry, but unfortunately those sails end up being full and inappropriate for strong winds. There will be more on this dilemma and trimming your sails accordingly in the chapter on sail trim. For now understand that the sail designer has to think about these differences and design the sail with them in mind.

Luff Curve

Because the mainsail is attached to the mast, it follows that the way in which it is attached will have an influence on the shape of the sail. For example, the sail designer designs a luff curve on a mainsail that he assumes will match the curve of the mast. In some cases he might add more luff curve than there is mast bend so that some of that excess curve can be fed into the body of the sail in the form of sail shape. Imagine, however, what would happen if the sail is set on the mast and the owner of the boat has the mast bent twice as much as the sail designer allowed. The curve of the mast would distort the shape of the sail, and all the thought and creative energy that went into the sail design will be lost. The same thing happens when the sail designer calculates the amount of headstay sag when designing a jib or genoa. In every boat there will be at least some sag in the headstay, so it's the designer's job to estimate just how much sag there will be and then design the front of the headsail to accommodate it. Imagine, however, what would happen if the sail designer was told, or assumed, that there was a hydraulic ram on the backstay to tighten and thereby straighten the headstay. If, after the sail is built, the designer finds out that there is no hydraulic ram his sail will not

fly as designed, since the excess headstay sag will affect the location of the draft in the sail as well as the leading-edge angle. In fact, this very thing happened in 1994 when I was involved with an Open 60 Around Alone project that called for the boat to have a 100-foot mast, and the designer decided to leave the hydraulic ram off the backstay in an effort to simplify the overall sailplan. As soon as we went out sailing, it was immediately obvious that we were going to have a problem, since without the ability to tension the backstay, and in doing so tighten the headstay, the carefully designed shape of the sail was largely ruined by the huge amount of sag in the headstay. Once again, the more accurate information the designer has the better job he can do for you.

Sail Design 101

The job facing the sail designer is challenging. He needs to take two-dimensional pieces of fabric and turn them into a three-dimensional aerodynamic shape. It's a complex process made more difficult by the fact that the force of wind will inevitably strain and stretch the fabric, at least to some degree, out of its initial shape, and while these stresses can be calculated in advance, creating a sail that is able to manage all of the various loads is not easy. The process has been made easier since the advent of stable fabrics and powerful computers, and with data banks of empirical data from which to draw, sailmakers are now able to get the flying shape of a sail close to the designed shape. Before we look at the three stages of design, let's first touch on the exact nature of loads since they are a critical component of the design process.

Loads—Catenary Versus Isotropic

There are two principal issues at work here, and they represent the primary differences between molded sails and paneled sails made from Cuben Fiber fabric. Since the early days of sail engineering there has been an underlying assumption that the loads in a sail radiate out from the three corners of the sail and then travel along catenary curves much like cables strung between two endpoints. The common thinking was that if you placed a fiber or bundle of fibers along this catenary, such as in a molded sail, and if they were of sufficient strength, then the sail would not distort when the load came onto the fabric. This thinking was most certainly valid and followed common engineering practices. But the problem was that as soon as the helmsman fell off from a beat the sail had to be eased out, and the loads no longer travelled along predictable lines. Catenary loading might be valid in general terms for primary loads, but it is not realistic when you know that a sail will be used through a wide range of conditions.

Sail engineers have long understood this problem and generally relied on films to take up on the off-threadline loads. This is a reasonable solution, but loading film results in its own set of issues. Film is weak relative to fiber, and when the film is loaded in a certain direction and caused to stretch, it shrinks on the axis opposite the load. The manufacturers of Cuben Fiber believe that no threadline model can ever be perfect, i.e., there will always be some load where there is no fiber unless the sail is built so heavy that it is impractical to use. Instead they

“The job facing the sail designer is challenging. He needs to take two-dimensional pieces of fabric and turn them into a three-dimensional aerodynamic shape.”

Wind Tunnels Versus Computer Programs

Modern computer programs allow the sail designer to create a computer-simulated wind tunnel that subjects the molded shape to forces of wind, heeling angle, and other mechanical loads. In the days before powerful computers, all critically important sails, like those for the America's Cup, would be scaled down and built, and those scaled versions would be tested in a proper wind tunnel. This kind of testing gave the sail designer some important information, although these days computers often do a better job. The goal of all wind tunnel testing and flow programs is to optimize the lift and drag ratios for the sail. Unfortunately, these flow programs only treat the sail as a solid shape and do not take into account the natural stretch and deformation that will occur when real loads are exerted on a sail. Computer-simulated wind tunnels are able to factor this information into the design. As a result, for really important projects sail designers use a combination of wind tunnel and computer analysis.

believe that it's important to engineer a sail that is "isotropic," in other words using a fabric that is strong in all directions. Cuben Fiber fabric relies on thousands of tiny filaments of fiber to introduce stability into a fabric rather than bundles running along primary load lines. The argument is clearly that since the loads in a sail are infinite and depend upon many variables, you can either attempt to engineer a sail that will do a reasonable job on all points of sail, or you can engineer one to manage the principal loads and suffer a little when they travel off the main catenaries. Since weight and cost also factor into engineering, some compromises have to be made. Molded sails continue to outnumber Cuben Fiber paneled sails so perhaps this argument does not have as much merit as it seems. Only time will tell how these two different approaches play out.

Bearing in mind that sails will undergo various loads and the design process includes dealing with these loads no matter how they occur, let's start with a blank piece of paper (or more to the point, blank computer screen) and work through basic sail design. We will look at the following steps:

- Geometry.
- Sail shape.
- Analysis.

Step 1 – Geometry

Once the sailmaker has your rig measurement details and understands the kind of sailing you plan to do, he can start the design process by figuring out the geometry of each sail. Perfect aerodynamic shape and engineering amount to zero if the sails do not fit, and this means more than just getting the luff lengths right and having the sail sheet to the tracks. The sail designer needs to take into account details like the location and length of the mast spreaders and where the standing rigging fits into the overall rig plan. For example, he needs to be careful that the design shape for a headsail does not have the sail going right through the spreaders when trimmed for sailing hard on the wind. He also needs to be sure that once the sailor bears away onto a reach that the sail can still be sheeted to the boat. The same points apply to the mainsail. The designer needs to take into account the location of the backstay and design the roach profile accordingly. There is no point in adding roach to the sail and then not being able to tack the sail through the backstay. He also needs to be careful when designing a full-batten mainsail that the batten locations do not coincide with the spreaders, both when fully hoisted and reefed. Point loading a batten on a spreader is looking for trouble.

The kind of sailing you plan to do also plays an important part in the geometry of the sails. If you are strictly inshore racing, the sail designer will keep the clew of the headsails fairly low and have the foot of the sail "sweep" the deck. On the other hand if you are heading offshore it might be useful to raise the clew so that waves can pass under the foot. This will also allow some visibility under the sail. Finally, the sail designer needs to be sure that there is some correlation between the sizes of different sails so that the sailor can reduce sail area and still keep the center of effort of the sailplan in the right location so that the boat remains balanced.

Step 2 – Sail Shape

There are two theoretical design shapes for each sail. The first is the molded shape; in other words, the static shape of the sail before it is subject to any loads. The second is the flying shape, i.e., the shape of the sail after it has been subjected to the force of the wind. The design process incorporates both the molded and flying shapes, and it becomes the designer's job to take both into account before moving on to Step 3, which is the part of the process that analyzes the interaction between molded and flying shapes.

Molded Shape – This shape is usually drawn from a data bank of known sail shapes and serves as a jump-off point for the design process. It is illustrated by horizontal and vertical cross sections of the surface of the sail and the measurements are called offsets. Offsets are a two-dimensional way to describe a three-dimensional curve. These offsets show the important design features of a sail, namely the chord depth, the position of the maximum draft, the angle of leading edge and the amount of twist in the sail. They are created for each section, or horizontal “slice” of the sail. Think of the sail design as a huge stack of individually created cambered shapes each with its own chord-depth ratio, twist, and maximum depth location. Stacking them on top of each other creates the overall sail shape.

Some sail designers have their own software that allows them to enter the boat's rig dimensions and deck hardware into the actual sail design program. This is fairly sophisticated and can be a great help in terms of the next step in the process, since it allows the designer to manipulate the sail and rig as one, and to address wind-flow issues over the entire plane, not just over individual sails. The mechanical properties of the mast and rigging can also be entered, including moments of inertia and a material's stiffness or resistance to stretch. Using this information, the designer can determine the deformation under load for the sail and every piece of standing and running rigging right down to the stretch in sheets and halyards. This kind of precise information is vital. If halyards stretch or the mast bends more than the designer anticipated, the shape of the sail will be affected. Being able to have some control over parts of the boat previously out of his realm allows the designer to have more control over his design. This control may only be in the form of knowing what to expect and designing the sail accordingly, but in any event it's useful knowledge.

Flying Shape – Once the designer is satisfied with the molded shape, he needs to subject the sail to the forces of the wind. This can be done by integrating it into a load program that exerts various loads on the sail. In addition to the rig information, the sail designer can input information about the fibers and fabric he plans to use. Drawing from a database of known stretch characteristics for different styles of fabric, the sail designer can see how a chosen fabric will stand up to the anticipated loads. The amount and orientation of fibers in a sail will have a tremendous effect on the flying shape of the sail.



North Sails tests their America's Cup sails in a modern wind tunnel facility that can even simulate twist in the wind.

Wind flow over sails can be displayed graphically on a computer allowing the sail designer to work on sail shape.

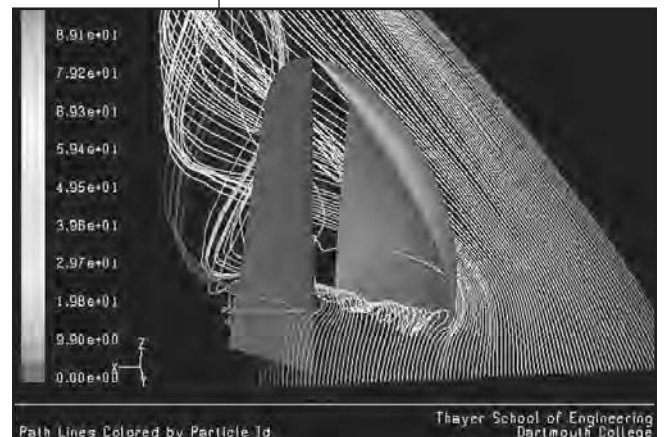

These load programs take the design and “flow” air over the surface at predetermined settings. These can include true wind speed (TWS), true wind angle (TWA), leeway, boat speed, and angle of heel. The settings can be changed at random and the result displayed in a series of pressure maps that show the various pressures on the sail at any given time. By entering the fabric information, the designer can determine just how effective the fabric choice will be in resisting stretch. This leads the sail designer to the next and most important stage, the analysis.

Step 3 – Analysis

Analysis is basically an extension of the initial load models and determines how the design distorts when it comes under load in the real world, in other words how the molded shape looks when it is flying. With all the relevant data programmed into the computer, the program will now start to compute how much and where the sail will distort when it comes under various loads. This distorted sail shape is then recreated as a molded shape and the new shape again run through the flow program. This back-and-forth process continues until the sail designer is happy with his design, i.e., when the wind and other forces will not over-tax the fabric, and when any potential distortion can be accommodated by engineering. The designer can also manipulate the sail mechanically and see what effect it has on the loads, and by extension, the shape. This manipulation can be in the form of easing or tightening the backstay, easing or tightening the sheet, or changing a sheet lead position. Modern programs are sensitive enough to respond to even the finest adjustments. Therefore, by careful manipulation and analysis, the sail designer can tweak the design until he is satisfied.

This part of the design process may last only a few hours if a similar type of sail has already been designed and built for a previous customer, or it may last a week or more if it’s a custom design for a high-stakes project like the America’s Cup or Volvo Ocean Race. Once the designer is happy with his creation, his initial involvement with the sail is finished and the process moves on to the next stage.

The Manufacturing Process—Turning the Design Into a Sail

With the theoretical work done, the practical work now begins, i.e., the design that is sitting in a file on the sail designer’s computer needs to be turned into a sail for the customer. These days many design office computers are linked directly to the production floor, and with a click of a mouse the design can be transferred and production started. In other lofts the design is taken either to a lofting table or to the plotter, and the sail is cut.

It was not always a simple process. Let’s look back to how sails used to be made and indeed how some lofts still manufacture sails. These modern manufacturing methods are good, but they are not imperative. Many sailmakers still make great sails the “old-fashioned” way.

Despite advances in sailmaking, some of the process like sticking seams together still needs to be done by hand.



The Five Steps to Making Sails

Step 1 – First Layout

Back in the days before computers, the process began by having someone work from a hand-written design to draw an outline of the sail on the loft floor using awls to mark the corners of the sails and a string to scribe the edges. The dimensions were taken from the design and included allowances for leech hollow, luff curve, and foot round. If it was a common design the outline may have already been marked on the floor with a pen. If it was a custom job then it all had to be done from scratch. Once the outline was ready, a bolt of fabric was rolled back and forth across the string layout overlapping the fabric just enough to allow for a seam. When the fabric completely covered the area, the panels were ready for step two.

Step 2 – Broadseaming and Sewing

There are two ways to add shape to an otherwise flat surface. The first is to draw a convex or “positive” curve down the luff of the sail so that when the curve is placed up against the straight edge of a mast or headstay, the extra fabric is pushed into the sail as shape. While this sounds rudimentary, it’s actually quite effective, although it does not give the sail designer much control over the overall shape. To create a more consistent shape throughout the sail, designers can also employ a technique called broadseaming (Figure 6.10), which involves adding a curve to one edge of each of the panels so that when the curved surface of one panel joins the straight surface of the panel below it, that surface, like the mast against the luff curve, will force shape into the sail. Think of a beach ball. You take a number of flat pieces of plastic, curve the edges and join them together. The result is a hollow sphere.

When it came time to assemble the sail the excess fabric would be cut away with a hot knife that melted and sealed the edge of the fabric. One edge of each seam would be taped with double-stick tape and stuck to the edge of the adjacent panel until the entire sail was all stuck together. It was then rolled up parallel to the seams and taken to the sewing machine pits for sewing.

The sewing machines were sunk into pits so that the working surface of the machine would be level with the floor, which made it easier to sew the seams. For big sails many lofts would use a roller, actually a series of rollers built into an oblong box, which was then tilted toward the machine. With the sail on the box it would slide easily down toward the sewing machine. Once the sail was sewn together, it was ready for second layout.

Step 3 – Second Layout

With the sail in one piece it was returned to the loft floor and laid over the string pattern to see if the sail geometry had shifted during broadseaming. Sometimes the sailmaker would need to remark the head, tack, or clew on the fabric. After that the sailmak-

Figure 6.10

To create a consistent shape throughout the sail, designers employ a technique called broadseaming.

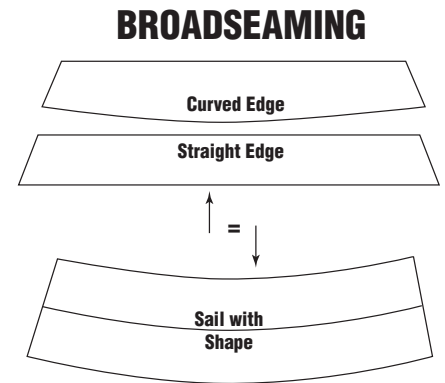

The edges of fabric are trimmed with a hot knife that not only cuts the fabric but seals it to stop it from fraying.

Sailmakers roll the sail once it is stuck together so that it can pass through the sewing machine.





Sewing machines are sunk into pits so that it's easier for the seamstress to handle large, cumbersome sails.



Sails are placed on rollers angled toward the sewing machine make it easier for the seamstress to handle large sails and sew a straight row of stitching.



er would draw the luff curve on the sail, a fairly critical part of the design process since the luff curve had to match the curve of whatever spar the sail was going to be set from. If the sail was going on a bendy mast, the curve needed to compensate for the bend while still adding shape. Likewise, a jib luff had to be cut for a particular headstay, taking into account sag. In terms of actually creating this curve the first thing the sailmaker needed to “remove” the shape from the sail since it now had an aerodynamic shape, and that shape, when laid flat, would push out at the edges and create a false edge. This he could do in one of two ways depending on the project at hand. For small sails he could “fan” the sail. In other words he would pin the tack and clew to the floor, and while standing at the head fan the fabric in an effort to trap a pocket of air between the floor and the sailcloth. Once he had a good pocket he would tack the head to the floor. With the body of the sail puffed up in its aerodynamic shape, he could then scribe the luff, leech and foot curves. For larger sails the best way to remove shape was by taking a fold behind the luff (Figure 6.11), i.e., laying the sail out on the floor and flaking it parallel to the luff so that the broadseam shape would be sucked up by the fold and the luff would lie flat and true. It would then be possible to lay a batten down the length of the luff, bend it to match the design offsets and draw the luff curve. The same would then be done for the leech and foot. After the excess fabric had been trimmed, the sail was ready for the next stage.

Step 4 – Finishing

At this point the sail was an aerodynamic shape built from a fabric that was appropriate for the job for which it was designed. Still, it needed to be reinforced in the corners and have edge tapes sewn around its entire border in order to withstand the rigors of wind and waves. Then the head, tack, and clew patches, and reef patches would be constructed from multiple layers of fabric cut to different sizes. The aim was to create a patch that had the required strength at the corner of the patch while tapering down toward the body of the sail. The loads in a sail diminish as they get further from the corner, and the sailmaker wants a smooth transition from the patch into the body of the sail. Triangular patches were (and are) the most common kind of patches, but patch technology has evolved, and now these once over-engineered pieces of fabric are a sophisticated part of the overall engineering process.

Part of the second layout process is drawing the luff curve on the sail. Here workers at the Quantum Loft in South Africa draw the luff curve on a large mainsail.

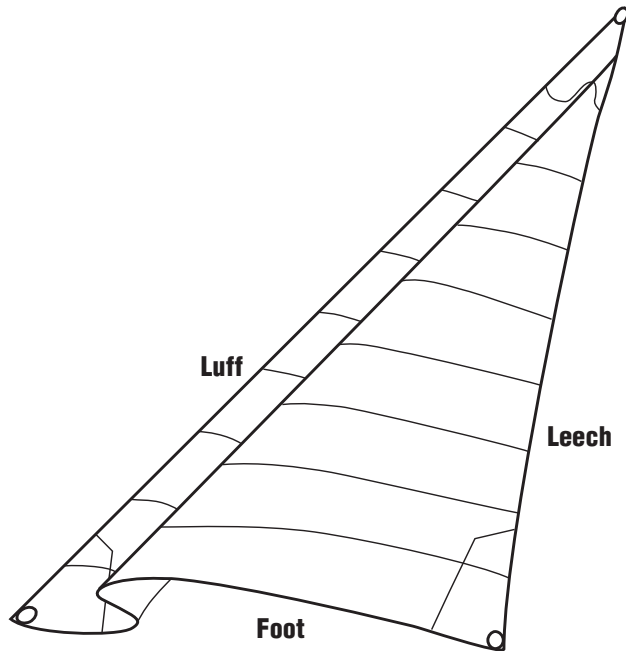

Flake the sail parallel to the luff to remove the shape from the sail.

Once the patches were stuck down with double-stick tape and sewn onto the sail, the batten pockets would be attached to the main and the edging sewn to the sail. The edges in high-load areas would be treated accordingly, and depending on the size of the sail, there could be either one, two, or as many as three layers of edge tape sewn onto a sail, with each tape cut successively smaller to facilitate a smooth transition. A sailmaker always tries to avoid any abrupt changes in fabric strength or “hard spots” in a sail since these hard spots will later become a “hinge” or weak point as the material bends repeatedly along a single line instead of flexing smoothly across a broader area. Luff tapes, or bolt ropes, would be added if the design called for it, or regular tapes would be sewn onto the luff if the sail had hanks. Leech and foot lines would then be run inside the edge tapes, and the sail would be ready for the final stage of the sailmaking process.

Step 5 – Handwork

At this point rings would be either sewn or pressed into the corners, hanks either sewn or bent onto the luff, cleats screwed onto the sail for the leech and foot lines, the head-board, batten, and luff hardware (in the case of a mainsail) attached, and leatherwork hand-sewn around chafe areas. After this final detailing was done, the sail would be

Figure 6.11

For larger sails the best way to remove shape is to take a fold behind the luff.

A basic reinforcement patch showing graduated layers of fabric distributing the load out into the body of the sail.

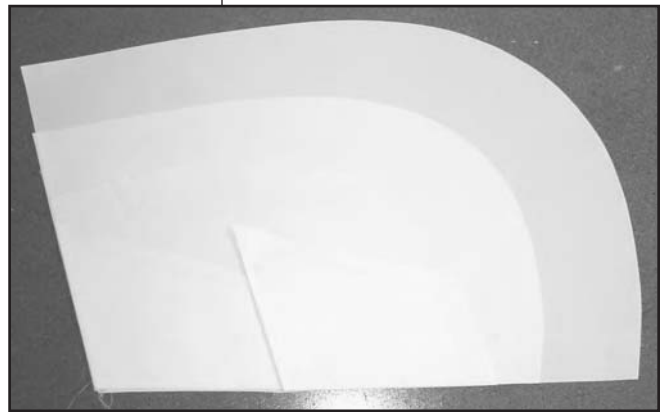

A slightly more sophisticated patch made from radial panels.

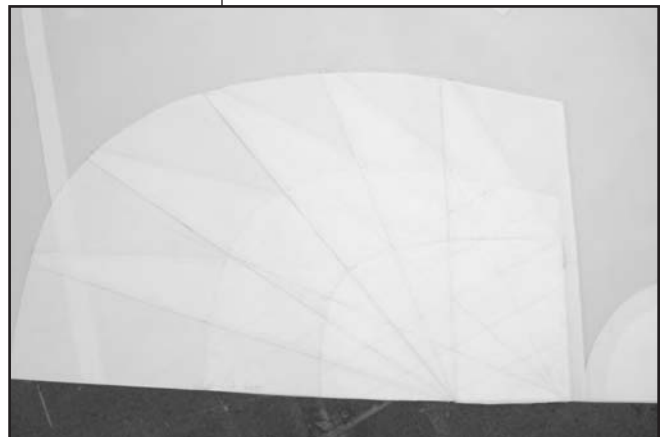

A mainsail for an Open 50 being finished with heavy tapes along the leech and luff. Note the leechline exiting the tape near the head of the sail.

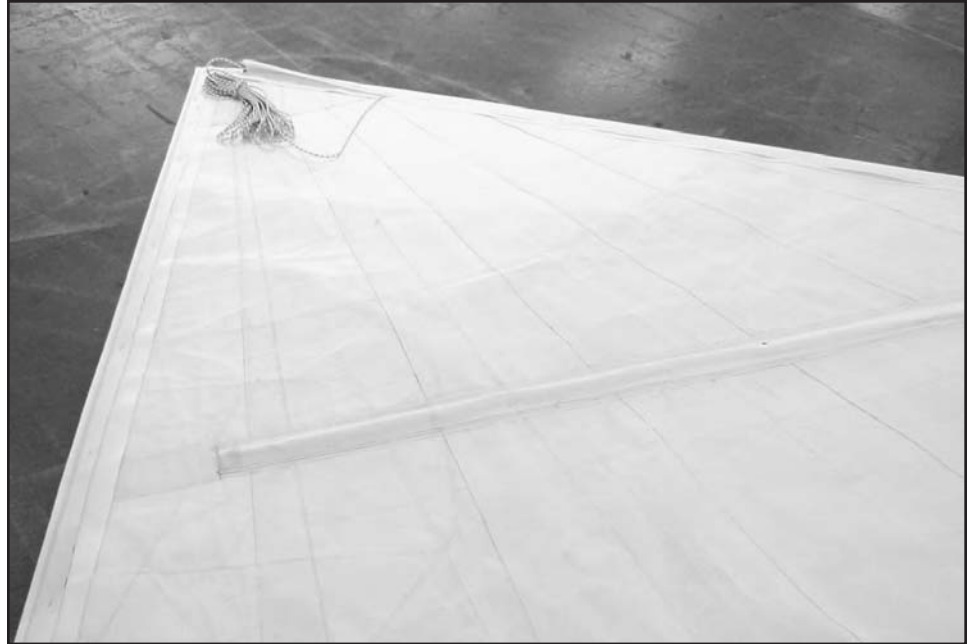

stretched out with pulleys holding the three corners and put through a final inspection. The shape that you saw when the sail was strung up was its molded shape. Once the sail was set on a rig and subjected to the winds and waves, things would change. But for the moment the sailmaker's work was done. It was time to sign the warranty card and ship the sail.

Sailmaking Today

Modern sailmaking is still a multi-step program, but computers and laser cutters have eliminated some of the early steps, making things much easier and more precise. It all comes back to the sail designer now being able to work with stable fabrics and having a database of proven designs to build upon. For example, in the old days the sail had to be returned to the floor once it was stitched together to draw the luff, leech, and foot profiles. Both this second layout process and the first layout took up an extraordinary amount of space, and sail lofts had to be large enough to allow a sail to be spread out on the floor. These days with the help of computers, the exact shape of each individual panel can be precisely computed in advance instead of unrolling bolts of fabric on the loft floor, thereby eliminating the need for first layout. Since these panels already include the sail's precise luff, leech, and foot curves, there is no need for the second layout either. This applies to both radial and cross-cut sails.

Once the sail designer has created the design, with a click of his mouse he sends it to production where the production manager is ready to turn flat panels into a three-dimensional shape. Some lofts do not

Near the end of the manufacturing process workers do the detail work like adding cleats and hand sewing leather on corner rings.

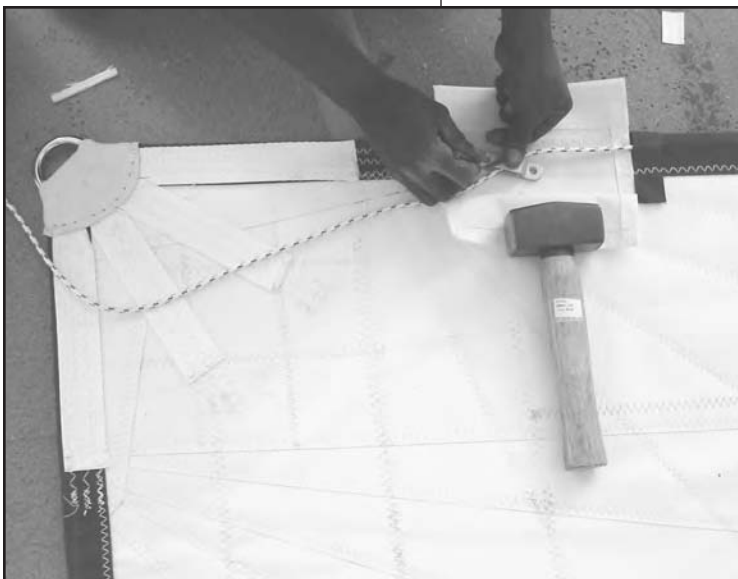



Workers use a hydraulic press to install heavy rings in the corners of sails.

have laser cutters, and in these cases the design is drawn on the fabric with a plotting machine and the panels are cut out by hand. Laser cutters save that step, but they are expensive.

Nesting the Design

Before the panels can be cut the production manager has to first “nest” the panels. Here the individual panels are oriented on the computer on a simulated roll of fabric, and the individual panels are arranged where their orientation takes the most advantage of the fabric’s strength while minimizing waste. It’s a critical step, and once all the panels are laid out, the design can be sent to the laser cutter or plotter for the next step. In either case, once the roll of fabric has been laid out on either the laser table or the plotting table, someone inspects the fabric for flaws and blemishes, and if satisfied, the process of creating the individual panels takes place. One at a time each panel is cut and marked so that all the individual pieces can be pieced together with the panels going in their proper place. They are then taped with double-stick tape, glued together, and the assembled sail is sent to the floor for stitching. The rest of the process is as described above.

The art of making sails is constantly evolving as newer construction techniques and manufacturing methods are developed. While computers and modern machines have made things easier, it is still a labor-intensive business. There are many steps and

A plotter scribes the design of each panel on the fabric.

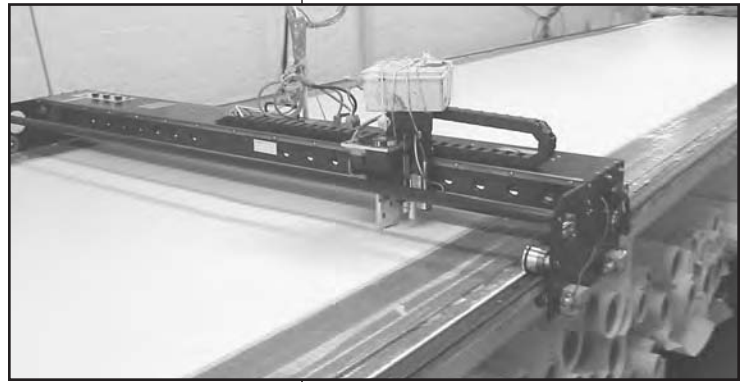

Hand sewing leather on corners is time consuming and tedious, but the wax threads lend an air of tradition to a sail and add durability.





Part of the Around Alone fleet leaving Torbay, England, at the start of Leg 2 of the 2002/03 race.

stages and as a result there are places where things can go wrong. It's hard to put too fine a point on this, and at the risk of constantly repeating myself, the more information you provide your sailmaker, the better it will be for your sail. Sailors are as individual as their boats, even those who have production boats, and sailmakers are hopeless at guessing. Now that you have an idea of what goes into sail design and production, you will have a greater appreciation of how many details and variables need to be taken into account just to get a sail that looks good and fits the boat properly. Stage one is now complete – at this point you need to decide what features you want on each sail so that the finished product complements the kind of sailing you plan to do.

Chapter 7

THE DEVIL IS IN THE DETAILS

A Close-Up Look at the Individual Parts of a Sail

A good sail is the sum of its parts, and the detail work that goes into a sail counts for as much as the fabric, engineering, and designed shape. It's important to know not only what these details are, but whether or not you need them on your sail. Getting the details right comes from asking more of the right questions. The answers will influence the kind of sails you end up with, and ultimately how happy you will be once you begin using them.

Remember that sails are no different from any other item you buy. You get what you pay for. If you invest in fabric and construction detailing, you will get a sail that looks better and holds its shape longer. If you measure the usefulness of a sail by how long it looks good and does a good job, then a larger investment up front will pay off over time.

Also bear in mind that buying a sail that is overbuilt or over engineered for your needs is almost as bad as buying one that is underbuilt. If you daysail out of the Florida Keys, for example, you don't need a sail built to withstand the rigors of a Newfoundland gale. Likewise, you wouldn't want to cross the Pacific with sails engineered for a summer afternoon off Sausalito. Give some thought to where and how you like to sail, and make sure that your sailmaker understands your plans. The differences in sail engineering are subtle, but the result will be a sail inventory that is just right for you and your boat.

These same questions apply to racing sailors. In fact, racers have a few additional ones to answer as well. For example, you need to be honest with yourself about your level of expertise and that of your crew, and you need to decide at what level you wish to play the game. Sailboat racing, at the top end in particular, is one of the most expensive hobbies there is, more so than horse racing and right up there with automobile racing, so deciding up front where and how you want to race will not only save you heartache down the road, but also a lot of money. It's one of the cruel realities of sailboat racing that money can buy a lot, but it can't buy everything. You still need to be able to handle both your boat and your crew. Racing sails built using the finest fibers and the latest technology are highly engineered pieces of equipment, but you need to know how to use them. This is not only so you won't damage them, but also so that you can get the most out of them. A sail designer will create a very different sail for a top-level experienced sail trimmer who knows how to get the most out of his sail than a trimmer who simply places the lead in a fixed position and cleats the sheet. The differences are subtle, but they are there, and for you to be happy the designer needs to know how the sails are going to be used.

Fabric and Engineering Considerations for Cruisers

Let's start by looking at the options open to the cruising sailor. The first decision will be about fabric, since your choice will have an initial impact on the panel

“... bear in mind that buying a sail that is overbuilt or over engineered for your needs is almost as bad as buying one that is underbuilt.”

layout and ultimately on your budget. While a number of fabric choices exist, for most boats in the 30- to 50-foot range, it really comes down to only three, and they remain the same no matter what kind of sailing you will be doing: durable Dacron for a woven, cross-cut option, and either laminated Polyester or Pentex for radial construction. The fabric engineering of these latter two options are similar, but as discussed in Chapters 2 and 3 the way the yarns are treated and the manner in which they are used make for very different fabrics.

Remember that one of the great benefits of radial construction, in addition to precise sail shape, is that the sailmaker can use varying weights of fabric in the same sail, combining different fibers in the fabrics and then incorporating them into the sail to end up with the lightest, most versatile sail possible. Again, light sails are easier to set and trim, especially in light winds, and if the sailmaker has used fabric efficiently, the sail will hold its shape longer and cover a broader wind range. These are important considerations. Trimming and changing sails is taxing on the crew, and as an overall part of good seamanship, it's important to keep this in mind. It's also important from a performance standpoint to do what you can to avoid weight aloft, even if you're just going for a daysail or a weekend cruise. Lighter sails do not add to the heeling and pitching movement of the boat the way heavier sails do, and this has an effect on the comfort, and by extension, the safety of the crew.

So why not just choose a radial sail every time? In a word: price. Two dominant factors affect the cost of a sail – the fabric and the labor – and on both fronts they cause radial sails to be more expensive. Specifically, laminated fabric is more expensive to produce, and radial sails require more work to manufacture since radial sails have more panels. As a result, for yachts up to 35 feet in length, woven Dacron would be my first choice. There are numerous styles to choose from, the price is reasonable, you can be sure that the sails will last a long time, and smaller boats do not place an undue strain on the sails, so a good-quality Dacron offers good value. Moving up to the low to mid 30-foot range, however, you might begin to consider a laminated polyester, since these boats start to generate loads on the sails where a laminated fabric will be a good option. Dacron will still do a good job, but at least consider a laminated sail, especially if you have a heavy boat that does not heel easily since this will place more strain on the sails than a light boat that heels quickly, thus spilling off some of the load. Between 40 and 45 feet I would recommend a laminated Polyester or Pentex. Certainly above 55 feet, an exotic yarn like Spectra or Vectran would be a good choice and a good investment because of the magnitude of the loads involved. Always remember, especially with larger boats, that an investment in fabric up front will pay dividends in the long run. In the Appendix there is a breakdown of recommended fabric choices for different size boats.

Attributes of light sails

- **Easier to set and trim.**
- **Less weight aloft.**
- **Reduces heeling and pitching.**

Fabric and Engineering Considerations for Racers

For the racing sailor, fabric is an even more important consideration since sail shape is critical to speed, although some of the decision making might be taken away by class rules, in which case you will have to stick with what's allowed. Otherwise, it comes down to those previously mentioned questions like, do you have the skill to get the most out of a Kevlar 3DL sail or would you do just as well to buy two laminated Pentex sails for the same cost? If carbon fiber is allowed will it make that much difference when the skill of the helmsman is questionable? My experience has always been that more gains can be made from learning how to set and trim the sails you have than simply buying new sails. You need to know how to get the most out of them.

Once you have made a choice regarding fabric, it's time to consider what features you want to have on the sails. Remember that these features set apart good sails from ordinary ones, especially if they are appropriate for the kind of sailing you will be doing. Let's start with the mainsail. It is, after all, your "main" sail.

Mainsail Details for the Cruising Sailor

It used to be simple. In the old days your sailmaker offered you one kind of mainsail and sailors were generally happy with the result. You got a sail with a moderate roach, four battens to support that roach, a few reefs and some sail trim devices like a cunningham and flattening reef. Today, mainsails seem to come in all shapes and sizes with a wide variety of options: You can get a "regular" mainsail with short battens; a full-batten mainsail or a 2-plus-2 mainsail with two full-length battens up high and two regular-length battens down low; a mainsail that rolls up into the mast or a mainsail that rolls into the boom; a mainsail with a small roach, a moderate roach, or a massive roach like those found on performance catamarans or many offshore solo racers; a mainsail with inflatable battens, vertical battens, or battens that "swing away" when not needed; or a mainsail with a single "conventional" reef, a single deep reef, or two or even three reefs. You can also have a flattening reef, overhead leechline, double overhead leechline, a cunningham, and either a loose foot or a foot shelf. And then there is the issue of whether to go with or without a headboard and the question of luff attachment hardware. If all this is starting to sound like something from Dr. Seuss—you have them with a luff, you can sail them in the buff—my point is that the options are almost infinite. Your problem is to decide what kind of mainsail is right for your particular sailing application. Before we look at the different mainsails and compare their strengths and weaknesses, let's look at some of the features that come standard with most mains.

The Cunningham

Located a small distance up the luff from the tack is the cunningham, generally a pressed-in ring reinforced with webbing straps that is used to adjust the amount of tension on the luff of the mainsail, which in turn controls the location of the camber in the sail. You can also use the main halyard to adjust luff

“ . . . more gains can be made from learning how to set and trim the sails you have than simply buying new sails. You need to know how to get the most out of them.”

tension, and indeed some racing sails on smaller boats no longer have cunninghams. But it is easier and less likely to cause a problem if you take up on the cunningham, since among other things, adjusting the luff with the halyard requires a lot more tension, not only because you have to raise the whole sail fighting against gravity and the tension of the mainsheet, but also because there is friction in the luff attachments. The compression load exerted by the main halyard on the mast is also something many sailors wish to minimize. In short, feeding a line through the cunningham ring achieves the same results as taking up on the halyard without the complications.

Foot Shelf

The foot of the sail is one of the most versatile edges of the sail when it comes to manipulating sail shape, since small adjustments can make big changes in the overall depth of the sail. In moderate winds or choppy conditions you can ease the foot out to add shape to the bottom of the sail, thereby providing more power. Or you can tighten it up to flatten the sail in either light air or heavy conditions. The foot shelf is shaped like a lens and once you pull on the clew it collapses and flattens out, pulling down on the middle part of the sail, removing shape from the bottom of the sail and flattening the overall profile. Many conventional mainsails are still attached to the full length of the boom by a foot shelf. And in fact, old sailing rules such as the IOR rule dictated that the sail had to be attached to the boom using either a bolt rope or slides, but that has changed. With more modern booms and hardware it's no longer necessary to have the sail attached unless you are a cruising sailor that plans to use the foot shelf for collecting rain water. Not only that, modern sailing rules like IMS and PHRF no longer require the sail to be attached to the boom, which has resulted in many more mainsails being loose-footed, that is they are attached at the tack and the clew only. This allows for more versatility in the sail and omits a

These old 12 meters are sailing with loose-footed mainsails. You can see the lens of light fabric hanging below the boom.



potential problem area, i.e., the foot attachment. In the past the bolt ropes would chafe through and slides break allowing the sail to rip free. Today, simply applying tension to the outhaul achieves the same result as collapsing a foot shelf. Many sailmakers still add a piece of light, lens-shaped fabric to the foot of these loose-footed sails, but this only serves to add sail area when sailing downwind. Once the shelf is not needed it can be rolled up and secured with a light Velcro strap.

The Flattening Reef

This “reef” is found only on cross-cut sails and is located a short distance up the leech from the clew. When cross-cut sails are designed they have a very important seam originating just above the tack of the sail called a “tack seam” that runs perpendicular to the leech and plays an important role in adding shape to the sail by feeding a large amount of sail shape into the body of the sail. Once you take up on the flattening reef by winding up on the reef line, it cinches the leech and effectively removes the tack seam from the overall shape characteristics of the sail. Once the tack seam is removed, the rest of the sail is much flatter and more appropriately shaped for stronger winds.

Edge Treatment

In years past sailmakers would simply table, or fold over the edges of sails and sew them down in order to keep them from fraying. These days, however, the edges of the sail are trimmed with fabric, usually a single or double Dacron tape, which serves to finish the sail cosmetically and add some stability to the edges of the sail. The tapes are also there for strength, and it’s often the size and number of tapes on a sail that indicate the quality and durability of that sail. Most boats up to 40 feet, for example, will have a single tape running around the sail. But above 40 feet there should be a second, larger tape sewn under the first one, and if the sail is being built for offshore passagemaking, then boats as small as 32 to 35 feet might have a second tape around the edges. These tapes are also for housing leechlines.

Leechlines

Wind exiting a sail creates small vortices, and these vortices can set up a reverberation along the leech causing the leech to flutter. Although the leech tape goes a long way toward solving this problem, on most boats you will still need a leechline installed down the very edge of the sail, i.e., a small-diameter, low-stretch line that can be adjusted and fastened off in heavier conditions. This way, when the wind increases and the sail begins to flutter, all you have to do to correct the problem is tighten the leechline. In light winds it can be eased off again so that the extra tension won’t cause the trailing edge of the sail to cup inward when there is less pressure on the sail. On small boats where the boom is easy to reach, the adjustment for the leechline is normally at the clew of the sail. But on larger boats where trying to make an adjustment at the clew would be impossible or impractical, the leechline is fastened at the clew and led over the top of the sail and down a pocket along the luff to an adjustment point at the tack. This way

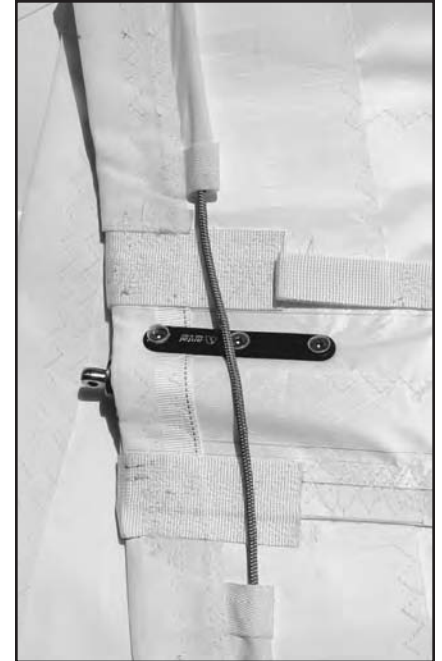

Special attention has been paid to the edges of this mainsail with reinforcement strips added above and below the batten pocket and at the point where the leechline enters and exits.

you can make the necessary adjustments safely and conveniently. A leechline installed using this arrangement is called an overhead leechline. Some larger yachts will even have double overhead leechlines, one running down either side of the sail. This way you will always be able to make an adjustment from the windward side of the mast instead of having to reach around to the low side on a sloping deck. With this setup you will also have a backup in case one of the leechlines fails.

Reefs

The size and number of reefs you need depends on your boat and the type of sailing you plan to do. There is really no point in having three large reefs in your mainsail when all you do is daysail on Long Island Sound since the winds are rarely that strong and there are plenty of places to find shelter in the event of a blow. The reef points add weight to the sail and expense. On the other hand, if you are heading for the open ocean you need at least two, if not three, reef points in case of severe weather. In fact, it would be poor seamanship to attempt an ocean crossing with a single reef. There are also other variables that need to be taken into consideration, for example, the stability of your boat and the way you like to sail. Some boats are very tender, i.e., they heel over easily, in which case a second or third reef would be important. Some sailors like to keep their boats on an even keel even when it is not blowing hard, so additional reef points will be important to them. No matter your preference, you need to remember that the reefs add weight to a sail, especially along the leech where it will affect your light-air sail trim. They also add cost to the sail. Making the reef patches and sewing them onto the sail, plus the tie-down patches running across the sail, requires time, effort, and additional materials.

Finally, bear in mind that the size and number of reefs in your mainsail will be influenced by the basic design of your boat and its sailplan, in the sense that the designer has planned the rig in such a way that you can reduce sail while keeping the center of effort where you want it relative to the keel. In other words,



The head of a mainsail showing an overhead leechline running through a small block mounted just below the headboard.

each sail change or reef is calculated to keep the boat balanced. Some boats, for example, need a number of small reefs in the main to compliment the reduction of headsail size, while others, usually sea-kindly cruising boats, are not as affected by balance, so large reefs are quite acceptable. Most offshore cruising sailors will tell you that they like the first reef to be deep, since when the time comes to take off sail area, they really want the boat to feel the difference. But many racing sailors, especially those who race inshore, prefer smaller reefs because a small reduction in sail area will allow them to keep their boats from being overpowered without slowing them down appreciably. In fact, many racing sails do not have any reefs at all. These sailors prefer to change headsails rather than reef the main because the result is a more efficient sailplan. They are also able to depower the mainsail in other ways, for example, by bending the mast, until the next mark rounding when they can change headsails. Knowing your boat and knowing your sailing plans will help you decide just how large each reef should be, how many you need, or if you need them at all.



A worker uses a mallet to bang in reef rings in a mainsail.

Battens

Battens are another area of considerable debate among sailors with the result that it often comes down to personal choice. If you already have experience with and are comfortable with a certain batten configuration, then maybe that's the best solution for you. On the other hand, you may want to consider other options.

Conventional Battens

The simplest batten layout is one with four short battens equally spaced along the leech, with the length of the battens dictated by the amount of roach the sailmaker is attempting to support (Figure 7.1). As a general rule, the batten length is the amount of roach, times two, plus a little bit extra. Because there is less roach at the top and at the bottom of the sail, these battens will be shorter than the two in the middle. This layout is not only the least expensive, it is also the lightest, making it easier to trim the sail in light air.

Full-length Battens

Full-length batten mainsails have all the battens running from luff to leech (Figure 7.2 on the following page). There is one important thing to remember

CONVENTIONAL BATTENS

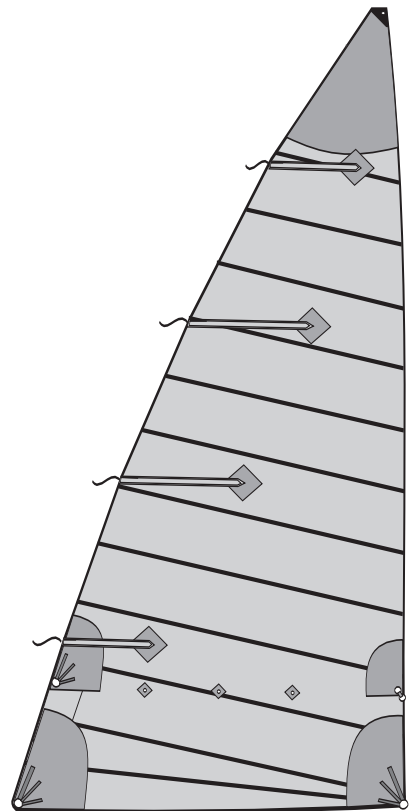

Figure 7.1

The simplest batten layout is one with four short battens equally spaced along the leech, with the length of the battens dictated by the amount of roach the sailmaker is attempting to support.

This traditional yawl has a mainsail and mizzen with conventional battens.



FULL-LENGTH BATTENS

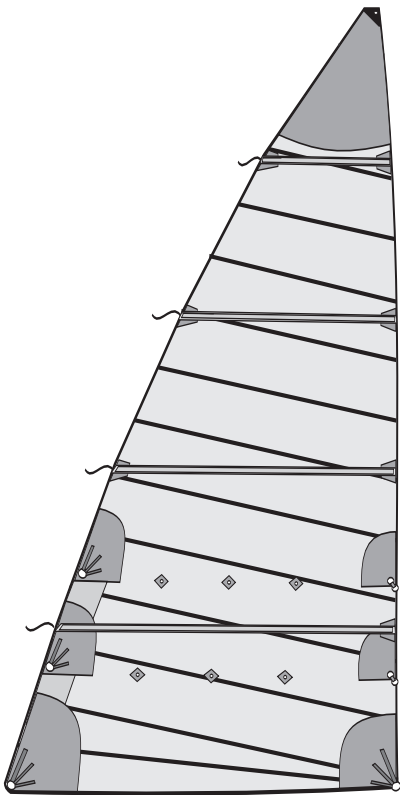

Figure 7.2

Full-length batten mainsails have all the battens running from luff to leech.

when it comes to battens: they will extend the life of your sail since battens add support to the fabric and dampen the flogging that is one of the principal causes of fabric degradation. Full-length battens also assist in keeping the shape of the sail looking good after years of service, whereas with conventional battens wrinkles start to appear at the inboard end of the batten pockets after heavy use. Mainsails that have a large roach like those found on Open Class race boats or cruising catamarans almost always have full-length battens to support the roach, especially near the head. On the down side, full-length battens add weight and cost to a sail, so the number and spacing should be judiciously considered. One possible solution is a 2-plus-2 arrangement with two full-length battens up high and two longer-than-normal battens down low. This gives you the support and sailhandling benefits provided by full-length battens, i.e., support for the roach up high, while avoiding weight and expense in other areas. Full-length battens also present a problem when sailing downwind, especially if the boat has swept-back spreaders, since when the sail lays up against the shrouds and spreader

ends the hard spot created by the battens rubs up against an equally hard spot on the rig, which leads to chafe.

Another drawback of full-length battens that you should be aware of is the fact that they can dictate sail shape in light air since they are not very responsive to standard sail shape controls like mast bend and adjusting the cunningham. This can especially be a problem if the battens are not properly tapered or are more rigid than they need to be. Let's say, for example, that you are sailing through a moderate chop and want to add depth to the lower third of the sail. Normally you would do this by easing off the foot, but if you have rigid full-length battens throughout the sail, they might end up dictating the sail shape down low regardless of what you do with your outhaul.

Another problem with full-length battens is that on mainsails with a larger-than-normal roach there is a lot of compression in the inboard ends of the battens, especially the upper battens where the bulk of the roach is located. When you sheet the mainsail on tight the load on the leech of the sail forces the batten in toward the mast loading up the slide. A good mechanical batten car system alleviates most problems, but just using "regular" slides may result in them jamming.

In the end it may come down to the size of your sail and type of sailing you are doing. Much of my own sailing has been done singlehanded and my last boat had an enormous mainsail with a huge roach. I relied on lazy jacks to manage the sail and lazy jacks work best with full-length battens since the battens help keep the sail material lined up with the boom. The added weight and expense was a worthwhile trade-off. If the sail had been smaller and more manageable, there would have been less need for full-length battens down low.



Full-length battens are necessary to support a large roach like the one seen on this sporty 30 footer.



Detail work on the outboard end of a batten pocket showing tensioning device (left photo) and cover (right photo) that prevents the sail from hanging up on the backstay.

Points in favor of full-length battens

- Can support more roach.
- Provide a smooth sail shape.
- Make the sail easier to handle with lazy jacks or similar mainsail-handling system.
- Improve durability by reducing flogging.
- Hold shape well even in light winds and choppy seas.
- Make flaking on the boom easier even in absence of lazy jacks.

Points against full-length battens

- Add to the cost of the sail.
- Add weight to the sail.
- Compression loads may cause problems on inboard ends.
- Chafe on rigging by providing hard spots.
- Dictate sail shape if the battens are too stiff.

This large sloop has an in-mast furling system, but you can see that there is no roach on the mainsail, greatly reducing the size and performance of the sail.



In-Mast Furling Mainsails

Along with roller-furling units for headsails, the in-mast furling mainsail is largely responsible for the growth of cruising in the last two decades, as well as the fact that larger and larger cruising boats are being sailed short-handed. Up until Ted Hood first introduced what he called the Stoway Mast in the late 1970s, sailors lived in trepidation of their mainsails, especially aboard larger boats. They were large, unwieldy and difficult to manage, and many cruisers in particular simply chose to leave them under the boom cover when they went out for a sail. Using typical Hood ingenuity, however, Ted created a mainsail that rolled up on a mandrill inside the mast cavity and allowed the sail to be easily furled into the mast. Furthermore, the furling could be done at the push of a button as an electrical motor turned the mandrill and reefed the sail. Suddenly, this unmanageable sail became a sailor's new best friend – safely overhead and easy to furl at the touch of a button.

Unfortunately friendships often come at a price, and in this case, in order for the mainsail to be rolled into the mast, the roach had to be eliminated since a roach needs battens to support it, and battens can't be rolled into the mast (Figure 7.3). This trade-off for convenience was an especially bitter one in that it not only meant the loss of sail area, but the loss of critical sail area as we shall see in the chapter on sail trim. And other trade-offs existed as well. For example, in order for the sail to fit inside the mast, the mast section had to be larger and usually heavier. This extra weight added to the heeling and pitching moment of the boat, aggravating comfort and performance. Then there were problems with

the systems jamming so that the sail was left either partially furled or deployed. Still, a compromised mainsail is far better than no mainsail at all, and other spar builders took up the in-the-mast furling challenge as well, working out the kinks so that today's systems are both safe and reliable. True, there are still occasions when they bind up, but most of the time it's operator error. For example, you need to take the pressure off the sail where it enters the mast cavity before starting to roll the sail away so you don't overload the system. To do so either luff the boat up toward the wind, or ease mainsail out. You might also want to keep a little tension on the outhaul so that the sail will roll up nice and tight inside the mast. If you are using an electric motor to drive the mandrel and it fails, you may have to rely on a small hand crank to roll the sail away. If this is the case it's even more important for you to make sure there is no pressure friction from the sail in the mast cavity. Like everything else in sailing, deciding whether or not an in-mast system is right for you is a personal choice. On boats smaller than 50 feet especially, there are other mainsail-handling options like full-length battens and lazy jacks, but on boats over 50 feet the mainsail can become a challenge. Assess all the parameters – the price, the weight, the fact that it can jam if not used properly, and the lack of performance from the sail – and then decide if it's right for you.

Gaining Performance From an In-Mast Furling Mainsail

Cruising sailors looking for a little more speed edge have always had to walk the fine line between convenience and performance. As sail technology develops, the margin between these two competing forces gets reduced little by little, and one of the areas where this is being done is in the increased ability to include battens in rollerfurling sails. There are three ways to add roach to an in-mast furling mainsail: vertical battens, swing battens, and inflatable battens.

Hand Cranking Across the Atlantic

In 1999 I sailed a well-appointed 44-foot cruising yacht from Newport, Rhode Island, to the Azores. The yacht was equipped with electric winches, a spacious galley, a push-button flushing head, and an in-mast furling system. It was, to say the least, heavily reliant on electrical power. Three days into the passage, however, the whole charging system collapsed, and my crew and I (we were sailing doublehanded) had to rely on alternative means to manage the boat. In addition to not having electric winches, which was certainly not a problem, we lost all the food in the freezer and could not use the stove because the gas shut-off sensor relied on electricity for it to function. Worst of all, the automatic in-mast furling system did not work because it was electrically driven and all reefing and unreefing had to be done with a small hand-crank that was attached to the mandrel. Three hundred turns of the crank would reduce the sail area by about 20 percent. We perfected the process by making sure that there was absolutely no friction on the sail where it entered the mast cavity. We also made sure that we reduced sail well in advance of approaching wind. It was an excellent lesson in remembering that sometimes simplicity is the best solution.

NO BATTENS

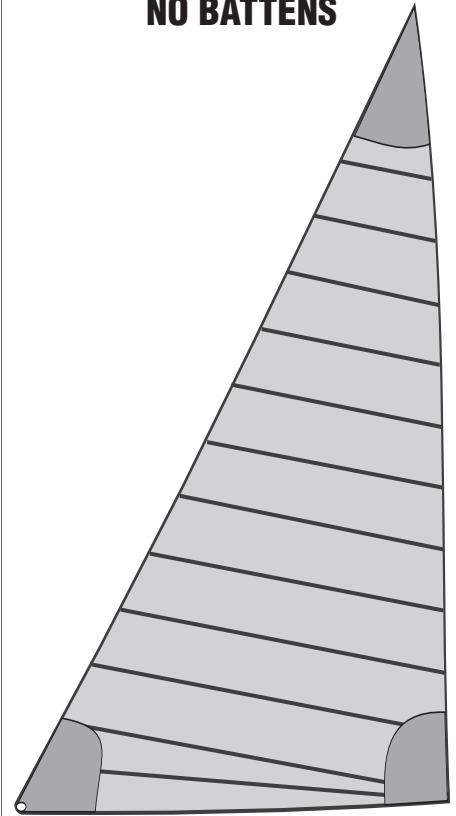
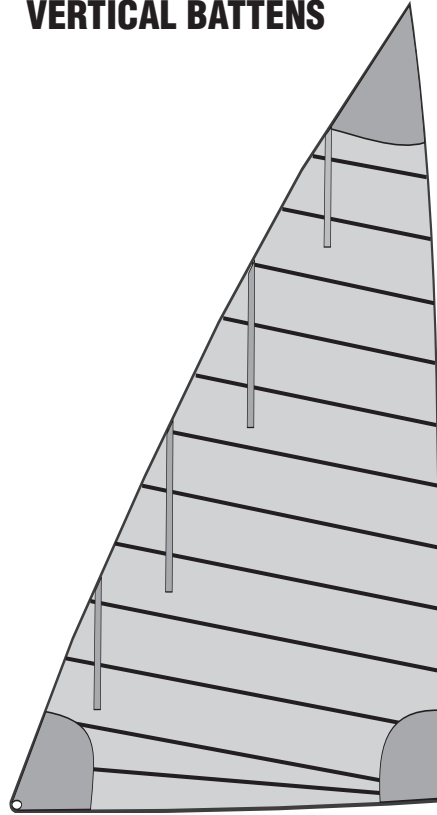

Figure 7.3

In order for the mainsail to be rolled into the mast, the roach had to be eliminated because a roach needs battens to support it, and battens can't be rolled into the mast.

VERTICAL BATTENS**Figure 7.4**

The first solution sailmakers came up with to accommodate in-mast furling was to replace the horizontal battens with vertical ones that can be rolled up inside the mast.

Vertical Battens

The first solution sailmakers came up with to accommodate in-mast furling was to replace the horizontal battens with vertical ones that can be rolled up inside the mast, and vertical battens have since found a permanent place on many roller-furling sails (Figure 7.4). There are, however, some drawbacks. For example, vertical battens have to be much longer than their horizontal counterparts to support the same amount of roach, and because of this they add quite a bit of weight to the back end of the sail. Specifically, the part of a vertical batten that extends beyond the straight line between the head and clew of a mainsail needs to be at least 10 percent longer than the part of the batten inside the imaginary line. Otherwise it will not support the roach. In light winds the back end of the mainsail will tend to collapse with all this extra weight.

One other point about vertical battens: They must always roll up on the inside of a furling mainsail. This way the pocket will not hang up on the mast cavity and add wear and tear to the sail. Make sure that the mandrel inside the mast is set up to roll the sail counterclockwise (looking aft) if the battens are on the port side of the sail, and clockwise if the battens are on the starboard side.

Swing Battens

In 2000 Doyle Sailmakers came up with an interesting new technology, which they patented. It's called a Swing Batten, and it's just that: a batten that swings from horizontal when the sail is flying to vertical when you want to roll the sail

SWING BATTEN

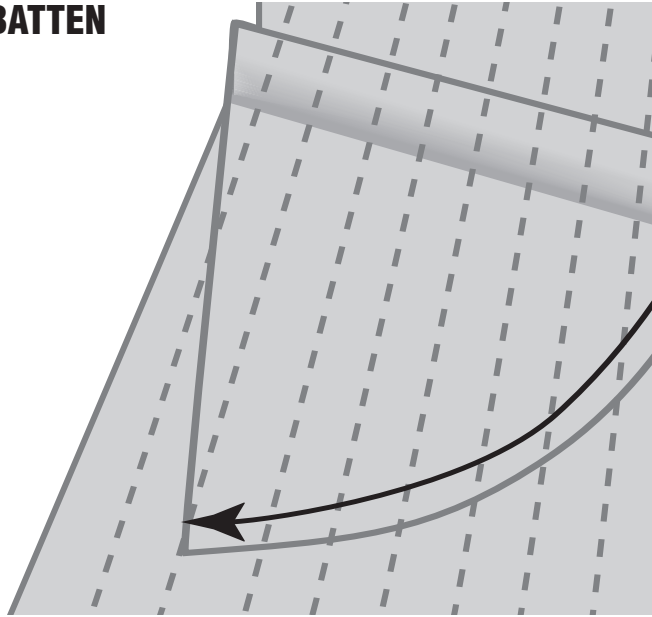

Figure 7.5

A Swing Batten is just that: a batten that swings from horizontal when the sail is flying to vertical when you want to roll the sail away.

away (Figure 7.5). This batten is hinged at the outboard end and is controlled by a continuous line attached to the inboard end. With the batten swung into place it acts like a conventional batten supporting a moderate amount of roach and adding sail area where it is needed most. When it comes time to roll the sail away, you simply pull on the control line located on the foot of the sail and the batten swings into a position parallel to the luff of the sail. The mainsail can then be rolled into the mast without any problem. While the Swing Batten is certainly a great idea, it does add one small level of complication to a sail, and it also adds to the price. For most sailors these details are easily overlooked when weighed against the advantages of the extra sail area. But for others any complication is one too many. Some sailors, especially those who value simplicity, will probably leave the battens off the sail.

Inflatable Battens

The third alternative is one that has been around for quite a while, but never really caught on. That solution is inflatable battens. It makes perfect sense since we all know you can get a very rigid batten just by adding air pressure, and of course when the pressure is removed the batten is as flexible as the sail itself. The reason, I feel, that inflatable battens have not caught on (yet) is that they add a whole new level of complication to a sail. Cruisers are looking for simplicity, and adding an air cylinder to a boat with the attachment lines that run up the luff of a mainsail and across the sail is more than many sailors are willing to contend with. There is also the problem of deciding when you have enough pressure and what to do if the whole thing stops working. Still, I am sure that in the not-too-distant future this option will be simplified and will become a part of everyday sail technology. It's too intriguing to leave out.

Undoubtedly these batten technologies will be refined in the future and new ones will emerge. For example, some sailmakers have tried making battens similar to the steel tape measurers carpenters use that are fairly rigid when extend-

The in-boom furling unit on this yacht is a neat and unobtrusive system.



ed, but are easily rolled away into the tape when not. Currently there are problems with these battens remaining rigid when in use. But down the road they may well find a foothold. In any event cruising sailors will always be looking to improve performance without sacrificing simplicity.

In-Boom Furling Mainsail

In contrast to in-mast furling systems, in-boom furlers, as the name suggests, have a mandrel running the length of the boom so that the sail can be rolled up horizontally as opposed to vertically in the mast. As a result, you can maintain a reasonable amount of roach on the sail since you no longer have a problem with conventional horizontal battens. There is one important point to consider, however: with in-boom furling mainsails the devil really is in the details, and you would do well to go to a sailmaker who has experience building these sails rather than one who is just learning. With that in mind let's look at some of the engineering details that go into developing a good in-boom furling mainsail. The tolerances are small, and while it's easy to get a system to work well while tied to the dock, the reality is different once you head offshore and attempt to throw in a reef in the middle of the night. In the following section on engineering details for in-boom furling mainsails you will learn how critical the sail design is to the overall process. It needs to roll up perfectly or the sail will bunch up and jam. In the end, avoiding these problems is a matter of both sail engineering and handling.

My First Introduction to In-Boom Furling

On that same trip across the Atlantic on the cruising boat with an in-mast furling mainsail, I also discovered how poorly a boat without a roach sails to windward. While we had been hoping for a downwind drag to the Azores, this particular trip was mostly upwind. As the boat leapt from wave crest to trough I cursed the day in-mast furling systems were invented. Without a roach it was impossible to get any lift out of the sail, and we had to tack through irritatingly wide angles, using the engine to coax any windward performance at all out of the boat until finally arriving in the Azores. Once there I went aboard a small cruising boat being sailed single-handed by a German girl, and she showed me her new in-boom furling system. It was a masterfully engineered piece of equipment that my friend told me worked very well, although she cautioned that it took her sailmaker a number of attempts to get the boom and sail to work as one.

“There are some details that need to be right,” she told me, and when I later researched in-boom mainsail designs, I realized that her comment about “details” was an understatement. The good news, however, is that if all the details are correct the systems work great, and they have been a real boon to mainsail handling since. And the German girl? I saw her a year later. She was still in the Azores, but not because of her furling boom. She had met a local man and her solo lifestyle had given way to another adventure – parenthood. She had married the man and they had just given birth to a baby boy. I repaid her for her boom advice with tips on changing diapers and raising babies.

Engineering Details for In-Boom Furling Mainsails

As shown in Figure 7.6 on the following page, there are a number of sail engineering details that are particular to in-boom furling mainsails.

Fabric

This is the single most important criteria since any distortion in sail shape can throw off the reefing system and you might end up with problems. While woven Dacron certainly works well on smaller boats, once you get into bigger boats and bigger loads you would do well to consider a laminate such as Pentex or Spectra. As we discussed in Chapter 4 these sails will be built radially rather than cross-cut, and this construction method allows for better fabric distribution throughout the sail. With more exotic sailcloth you will be able to reduce the weight of the sail and also reduce the volume of rolled-up material, two important factors that contribute to aesthetics and sail handling. The molded sails like 3DL, D4, and Tape Drive also allow for precise placement of the fibers, and they make good sails for use as in-boom furling mainsails.

Leech Plies

The second important point is that the sailmaker must build the sail with extra plies or layers added to the leech to build up bulk at the outboard end. This bulk compensates for the bulk caused by the bolt rope rolling up on itself at the

ENGINEERING DETAILS FOR IN-BOOM FURLING MAINSAILS

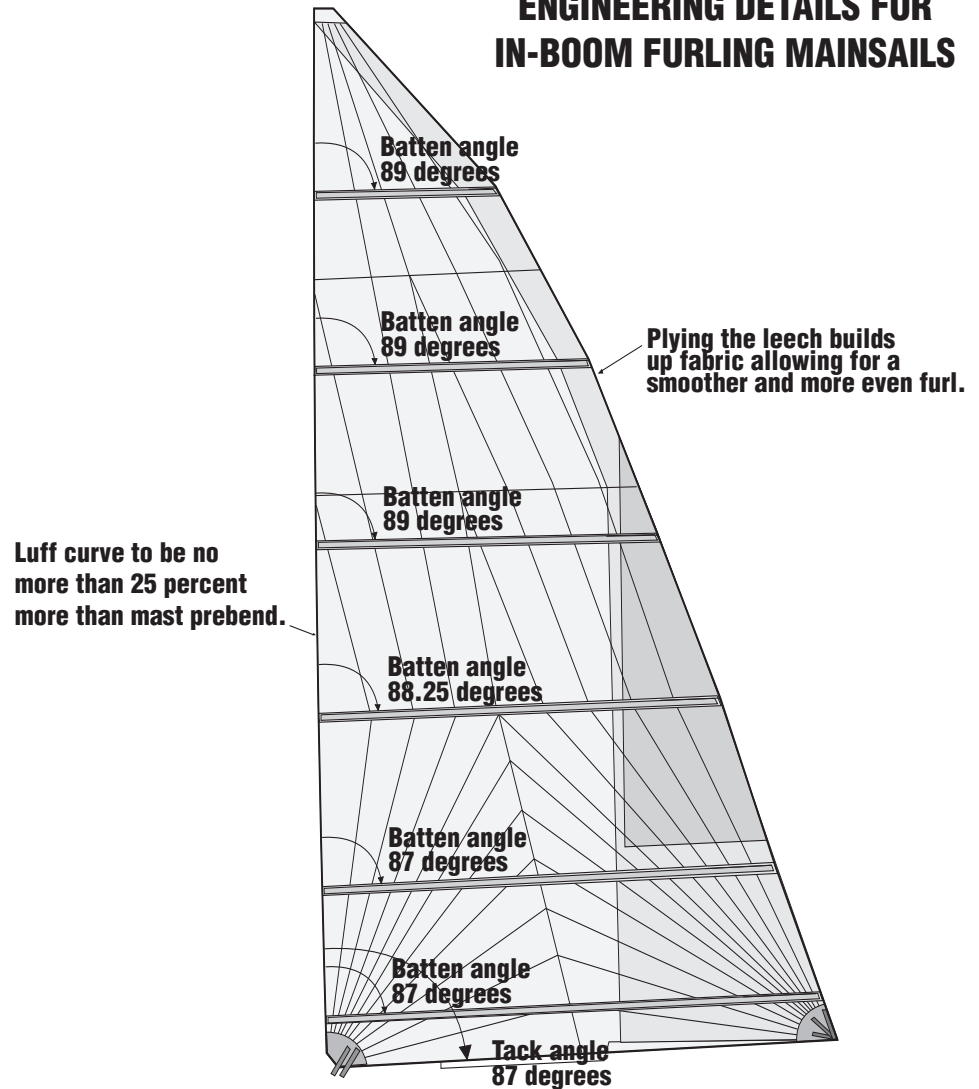

Figure 7.6
 There are a number of sail engineering details that are particular to in-boom furling mainsails.

inboard end. If the roll size is uniform, the sail can roll up evenly and not “travel” forward or aft as you reef. If you have ever tried to roll up a carpet, you will know what I mean. The top ply added to the leech can also be a UV-resistant fabric to protect the sail once it is furled away in the boom. It works the same way as the UV cover on your rollerfurling headsail.

Luff Tape

Another important part of the sail is the luff tape, or bolt rope. In fact, the boom maker will usually supply a bolt rope that it has had manufactured to its own specifications, and your sailmaker should definitely use this tape rather than attempt to create one of his own, since the boom makers have experimented with numerous types of luff tape and will provide the sailmaker with one they are comfortable can handle the extra loads. For example, there can be a lot of point-loading, especially where the bolt rope feeds into the mainsail track, so a conventional bolt rope will not suffice.

Luff Curve

As discussed in the previous chapter, sailmakers can build shape into a sail in two ways – luff curve and broadseaming – and boom makers usually recommend that a sailmaker add shape at each seam rather than with luff curve since too much luff curve may foul up the bolt rope as it stacks when reefing. Boom manufacturers usually suggest that the sailmaker add no more than 25 percent more luff curve than the mast pre-bend. If the mast has a pre-bend of four inches, for example, then the luff curve should be no more than five inches.

Full-Length Battens

In-boom furling mainsails are always equipped with all full-length battens since the battens can be used to both support the roach and facilitate reefing. In fact, the boom maker will not only specify the minimum number of battens, but more importantly, the exact angle at which each batten must be placed on the sail. There are usually more battens on a mainsail built for in-boom furling than a conventional sail since they not only stabilize the roach but facilitate reefing by keeping the sail stretched out while it is being rolled up. Boom makers also provide clear details on how both the outboard and inboard ends of the batten pockets need to be reinforced, since it's important that the reinforcement not create any unnecessary bulk, thereby throwing off the even roll-up. In addition, all batten pockets must be mounted on the same side of the sail so they will roll up inside the furled up sail, allowing the smoother outside to pass through the boom slot without hanging up.

Reef Locations

While in theory an infinite number of reefing positions are possible, it is best to reef to each batten. Specifically, you should reef the sail until the batten is just on the mandrel. That way the batten acts to keep the foot of the sail stretched tight and the bag out of the sail. This is especially important since the last thing you want in high winds is a full mainsail. Because these mainsails have more battens than a conventional full-batten sail, you end up with a number of well-spaced reef locations. The batten pocket itself lends reinforcement to the sail at each “reef point.” Note that batten material and stiffness is also a critical factor, and that the boom maker will likely recommend a batten company it can trust. As stated earlier, full-length battens have a great effect on the shape of the sail, so using battens that have the desired bend helps with sail shape and makes reefing easier. Stick with what the boom maker recommends for battens – the recommendations will serve you well.

Sail Profile

The overall profile of the sail is important. While in-boom systems go a long way toward providing a powerful main with sufficient roach to power the boat to windward, it's unwise to attempt to add too much sail area. Ultimately, an even curve from head to clew will provide an even rollup in the boom cavity. Try and stack roach up high in the sail like an America's Cup racer and you will find that the straight leech down low will cause an uneven roll with a lot of fabric bunching up at

The gooseneck and luff feed system on an in-boom furling unit.



A Personal Perspective

When roller-furling units were first introduced for reefing headsails there were a number of engineering problems that needed to be resolved before the units would work properly all the time. As a result, many sailors felt that it was not good seamanship to have a furling unit on a vessel heading off-shore. Over time, however, headsail furling units have come to be accepted and proven. Almost without exception, they can now be found on all cruising yachts. The same is happening with in-boom furling systems, and I believe we are on the threshold between experimental device and standard equipment. These systems will only get better, as will the skills of the sailors who operate them.

the outboard end. This is not to say that it can't be done, but if you choose to go this way you will need to exercise more skill and caution when operating the reefing system. Again it will help to have an exotic fabric to provide a tight roll and support the larger roach profile.

No Hardware

Make sure the sailmaker does not attach any hardware to the sail other than a ring or headboard car at the head. For obvious reasons, the smoother the sail, the better it will roll in and out of the boom cavity. Soft webbing at the tack and clew as well as smooth reinforcement patches for the battens will go a long way toward making reefing and unreefing an easy process. Even if you have a Dacron sail, insist that the sailmaker use Spectra or Kevlar for the leechline. These lines have great strength for their diameter, and having a small diameter line up the leech reduces bulk.

Installation and Handling

The next critical part of the system is the installation. If the sailmaker has followed the manufacturer's guidelines carefully and you follow their installation guidelines to the note, most systems will be trouble free. If not, you could be in for big trouble, especially when the wind kicks up. Make sure that you have all the right deck hardware to handle the system and that you have it mounted where you can operate all the control lines efficiently. For example, be sure that the furling line is close to the mainsail halyard so you can release one and take up on the other, all the while maintaining the correct tension on the halyard. Too little tension and the roll will travel forward; too much tension and the roll will travel aft. In my experience any boat larger than 40 feet should seriously consider an electric winch to help manage the system. Any boat larger than 55 feet must have an electric winch, unless there is a full crew on board that can work together as a team. Otherwise, the electric winch frees up a hand and makes the whole operation of reefing and shaking out reefs much easier. The boom vang is also an important piece of equipment when using an in-boom furling system, not so much for controlling leech tension, but for controlling boom height. This is because keeping the boom at the appropriate level is important for the sail to roll up evenly. If the outboard end of the boom is too high, the luff of the sail will start to travel aft. Conversely, if the outboard end of the boom is too low, the luff will travel forward. A hydraulic vang is necessary on boats over 45 feet, and a double-acting system, i.e., one in which you pump the vang in as well as pumping out, is necessary on boats bigger than 65 feet. Finally, be sure you follow the instructions for attaching the outhaul webbing. Ideally, you should leave a bit slack so that the sail has some fullness for downwind sailing. Then with one clever turn of the mandrel you can wrap it around the mandrel, tightening the foot and flattening the sail. It's a nice, added benefit to an already helpful system.

A Guide for In-Boom Furling Systems

To help you determine some of the details you will need for your system to work better, the following are suggestions for three different size ranges of boat size: At

the low end of the size range, say 35 feet, it is much easier to install and operate an in-boom furling system. The loads are not that great and any reefing system is quite manageable. Woven Dacron can still be the fabric of choice unless the boat has a high righting moment thereby increasing the load on the fabric. If this is the case you might consider using a fabric like Pentex. A regular vang or standard hydraulic vang will be fine, and if you are reasonably capable, then leave the electric winch off.

For boats between 45 and 50 feet, on the other hand, you will need a double-acting vang and certainly an electric winch. This will also be the range where you should seriously consider a more exotic fabric for the sail. At the low end a laminated Pentex or polyester will be a good choice, and at the high end possibly Spectra or Vectran.

For boats 60 feet or longer a high-tech fabric like Spectra is critical, as is a double-acting vang and electric winch. This is the size range where the extra performance of the full-size mainsail will really be felt, and also where installation and operation are most critical.

If you have followed these suggestions and all the guidelines set out by the boom maker and have installed the sail accordingly, the only watchword once you set sail is to use common sense. Plan your maneuvers in advance and be sure that you have pre-marked the halyard at full hoist and for each reef location. A simple trick to help when reefing (if you are sailing on the wind) is to oversheet the jib and backwind the mainsail. The backwind reduces the load on the bolt rope and the sail slides up and down easier. Spend some time fooling with the system on a sunny, warm day when the wind is light to familiarize yourself with the equipment. It will serve you well when you get caught in a squall and have to react quickly.

Alternative Mainsail Handling Systems

Despite these modern advances in mainsail handling hardware, there remains a constituent of sailors that scorns in-mast and in-boom systems, opting instead for a compromise between no system and a fully-fledged hardware package. For

Lazy jacks are an easy and effective way of handling a mainsail, and when combined with a boom with a recessed upper surface (left), the system is neat and efficient.



When sailing the stackpack rests against the mainsail out of the way.



those with a bent for simplicity there are some “discreet” mainsail handling systems that are very effective in controlling the sail.

Lazy Jacks

The simplest mainsail handling devices are lazy jacks. These pieces of rigging have been around for decades and over time have become more sophisticated. At their most basic, lazy jacks are a series of lines running from the boom to the mast that keep the mainsail on top of the boom when the sail is lowered. On some rigs they can be removed or lowered when the boat is sailing, then deployed at the end of the day. To increase their effectiveness some lazy jacks are attached to wings running along the boom that spread the base and allow the sail to fall neatly between them onto the top of the spar. Some sailors who find these wings unsightly have booms constructed with a wide upper surface, which serves the same purpose, but is less obtrusive. Others have even taken it a step further and engineered a concave surface on the top of the boom so that the sail disappears into the recess. Whichever system you prefer, lazy jacks work that much better if the mainsail has full-length battens to help control the sail. There is no upper limit for boats using lazy jacks. I have seen them used successfully on boats ranging from 30-foot day-sailers to 130-foot megayachts.

Stackpack

Doyle Sailmakers was the first to incorporate a boom cover into a lazy jack system, an idea that quickly caught on and has been copied by a number of other sailmakers. The object is twofold: The sides of the boom cover act as an effective way of gathering and taming the reefed or lowered mainsail; and once the sail is completely down, the top of the Stackpack can be closed to serve as a boom cover. The beauty of this system is that once the sail is raised, the sides of the boom cover lie out of the way snugly up against the sides of the mainsail. As with lazy jacks, there is no upper limit to Stackpacks.



The Dutchman

Working on a Roman shade idea, sailmaker Martin van Breems of the Dutchman Company came up with a similar idea for taming a mainsail called the Dutchman, a kit system that can be used to retrofit an existing mainsail or installed on a new mainsail. The secret is a series of grommet holes running the length and width of the sail. Fed through these holes are control lines that attach to fittings at the base of the sail. The control lines are also attached to the topping lift and run perpendicular to the boom. When the mainsail is being lowered or reefed the control lines tame the mainsail, so that it simply slides down the lines and flakes neatly on the boom.

The Dutchman works best on new sails because once the sail has been raised and lowered a few times, the fabric develops a “memory” and the sail starts to fold naturally along the same lines. By the same token the system does not work that well on old, soft sails since it’s hard for old sails to develop any kind of memory. Like the Stackpack and lazy jacks mentioned above, there is no practical upper limit to the size of sail that can have the Dutchman system.

Headsails for the Cruising Sailor

Fortunately, headsails are a far less complicated part of a sail inventory, although no less important. Without them the boat would just not sail as efficiently. While roller-furling units have become as common as anchors on sailboats, it was not always that way, and many cruisers, for good reason, will not switch from hanks to roller-furling. There is some merit to this argument.

Hanks for Headsails

Hanks may be old fashioned, but they are reliable, and if you change sails to suit the conditions, as opposed to just rolling up a piece of a genoa, you will always have a sail up that is designed specifically for the conditions, rather than a compromise. For example, a working jib designed for sailing upwind in

When at the mooring the mainsail drops into the Stackpack and the whole system stows neatly on the boom.

30 knots of wind will have a flat chord depth and a forgiving luff, perfect for sailing in that kind of weather. On the other hand, no matter what you do, a roller-furling genoa designed to sail in 12 knots of wind that is reefed will not have the correct shape, nor will it be engineered for heavy air. The initial chord depth, for example, will be much deeper than the working jib, the fabric lighter, and once you start to roll fabric away there is no way of keeping the location of the draft where it needs to be. Of course, the advantage to roller-furling is that it's convenient. With the flick of a switch or a crank on the winch you can reduce sail area quickly and efficiently. Again it's a balance between priorities. If you are an elderly couple sailing a 40-foot boat, for example, it will be better seamanship to have a furling unit rather than attempt to change headsails on a heaving foredeck.

Note that while hanks are reliable, they work best only if the sail has been engineered for them. Once the headsail is hoisted all the way the load is spread evenly between the hanks and the luff rope, but while the headsail is being hoisted it's a different story. Specifically, there is a lot of point loading at each hank and the

To Furl or Not to Furl?

I did my first circumnavigation in the days when Dacron was dominant, hanks were the only way to go, and headsail changes were a part of every watch. We sailed around the world via Cape Horn, and the memories of changing heavy sails in a heaving sea with ice-cold water crashing over the bow are as vivid today as they were 20 years ago. Thankfully, much has changed, and one of the great leaps forward in sailing technology has been the advent of the roller-furling unit. That simple, mechanical device, found these days on just about every ocean-going sailboat, has transformed the way we sail. Much to the chagrin of sailmakers, it has also reduced our headsail inventory to just a few sails. The challenge for sailmakers today is getting the sails right so that they cover a wider wind range and perform adequately through a broad variety of conditions.

It's important to understand the limits of roller-furling, and to think carefully about how these systems fit into your sailing plans. If you are a daysailor or weekend sailor and you rarely venture out of sight of land, it's probably fine to place all your faith in furlers. On the other hand, if you are heading across an ocean, my advice is to use a furler on the forestay, and have hanks on an inner forestay since nothing beats the security of hanks when the wind is up and the spindrift flying. With furlers the location of maximum draft, so critical to a sail's performance, is sucked forward as the fabric is rolled up on the foil, and even on the best-engineered sails the edges go tight and the body bags out. Don't forget that the most efficient way to sail a boat is to have a specific headsail designed specifically for the conditions: a large sail with a deep camber for light winds, and a small sail with a flat camber for heavy winds. Do not be deceived into thinking that one sail can do it all. The realities of sail design and engineering make it impossible.

sail needs to be reinforced accordingly. You might also consider hank-covers, small Dacron covers that wrap around the hank and fasten back on themselves, since hanks are a never-ending source of potential snag points for headsail halyards, spinnakers, and the like. Covering the hank stops an errant line from getting stuck behind the piston and causing problems.

Sail Engineering for Roller-Furling Headsails

As is the case with hanks, if the sail is going to be reefed on a furling unit, special attention needs to be paid to the engineering of the sail. One of the most difficult aspects of a reefing headsail is to engineer a sail that is light enough to fly when fully unfurled, yet strong enough to handle the loads when the wind is up and the sail reefed. Radial sails work better than cross-cut sails because the sailmaker is able to place strength exactly where it is needed. Cross-cut sails on the other hand, can have a second ply along the leech. But while this goes some way toward helping with strength, it's not absolutely critical. Be sure to discuss wind ranges with your sailmaker. Just because a sail is reduced in area to the size of a storm jib doesn't necessarily mean that it will be strong enough. Again, don't let anyone tell you that one sail can do it all; for coastal daysailing maybe, but for offshore passagemaking, definitely not.

Foam Luff Pad

Soon after roller-furling units were introduced, sailmakers found themselves faced with the problem of a reefed sail having a deep belly at a time when a flat sail was desirable. Basically, as soon as the first roll was taken, the edges of the sail got tight and the body bagged out, a situation that became worse with each turn. To compensate, sailmakers added a foam luff pad that runs the length of the luff of the sail. This pad, made of closed-cell foam, tapers toward the head and tack and is widest in the middle of the sail where there is the most shape. The actual fore-and-aft width of the pad is determined by the size and shape of the sail, and the end result is that as soon as the first roll is taken on the furling unit, the pad bulks up on the foil creating a fatter roll in the middle of the sail. With each successive roll this extra girth removes some of the depth of the sail, effectively flattening the sail where it is most needed.



The foam pad along the luff of this headsail will allow for a better sail shape once the sail is reefed.

Foam Luff Pads

more turns = more girth = more shape removal = flatter sail

Low-aspect sails need a foam luff pad more than high-aspect sails because they have more shape over a larger area to remove. While there may be less need for a foam luff pad on a high aspect sail, all sails will benefit from having one (Figure 7.7).

Even though it can remove shape, the luff pad does nothing to help keep the shape where it is needed most – approximately 33- to 38-percent aft. This is one reason why sails reefed on a furling unit are not nearly as effective as those designed specifically for the conditions, especially when sailing to windward.

UV Sunshield

For cruising sails, especially those used in sunny climates, a sunshield is a must. This acrylic- or UV-treated polyester fabric is laid along the leech and foot of the sail to protect it when it is rolled up on the headstay. The fabric does not add to the strength of the sail, but it does add to its life by protecting it. If aesthetics are important, your sailmaker can make a sacrificial sunshield from the same fabric as your sail and replace it when the fabric starts to rot. This is a slightly more costly option, but the sails do look nicer.

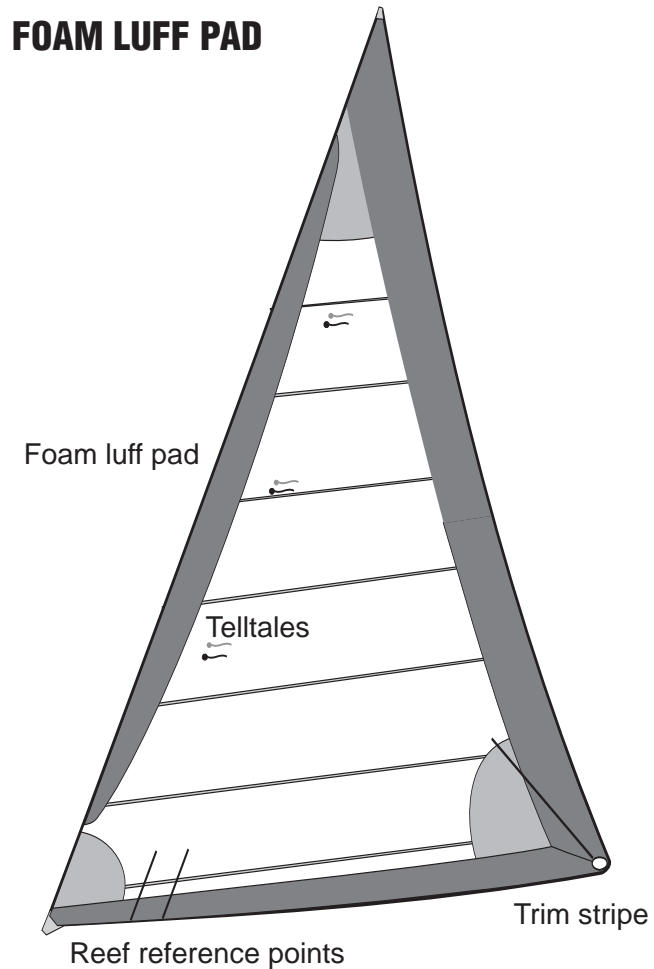

Figure 7.7

To compensate for a sail bagging out when reefed, sailmakers add a foam luff pad that runs the length of the luff of the sail.

Overhead Leechline

If your sails are high-clew, or if your boat is so big that you can't reach the clew to adjust the leechline, you might consider an overhead leechline running over a small block at the head of the sail and down the luff. This leechline will be adjustable at both the tack and clew. Note, however, that you will not be able to adjust the leechline at the tack if the sail is rolled up or reefed on a furling unit.

Extended Head and Clew Patches

The first portion of the sail to roll up includes both the head and tack patches, so they should be extended so that the corner structure is preserved when the sail is partially reefed. Otherwise, once the patches are rolled away completely you end up with two important parts of the sail effectively having no reinforcement. This is obviously not desirable at a time when you need more strength, not less.

Reef Reference Points

Your sailmaker should mark the foot of the sail with reference points so you will know by how much you are reducing sail area when reefing. This is important for the overall balance of the sailplan. It's also important so you can know where the sheet lead should be positioned when the sail is reefed. More about this in the chapter on sail trim.

Hank Reinforcement

If your sail is hanked on, be sure that your sailmaker adds reinforcement patches behind each hank. As soon as the load comes off the halyard there is point loading at each hank. This point loading can be fairly significant and could rip the luff of the sail if it is not properly reinforced.

Trim Stripe

To make it easier for you to trim your sails, your sailmaker should add a trim stripe at the clew of the sail. The trim stripe is a line that roughly splits in half the angle made by the leech and foot. This stripe is a good average reference point for you to use when you are trimming your sails. Sight down the stripe to your sheet and if the sheet is in line with the stripe, you can be sure that your sail is trimmed correctly.



A UV sunshield down the leech and along the foot of a headsail can help protect the fabric when the sail is furled and extend the life of the sail.

Figure 7.8

The moment you reef the sail your sheeting position changes, and unless you have a way of adjusting the sheet lead, you quickly lose all performance.

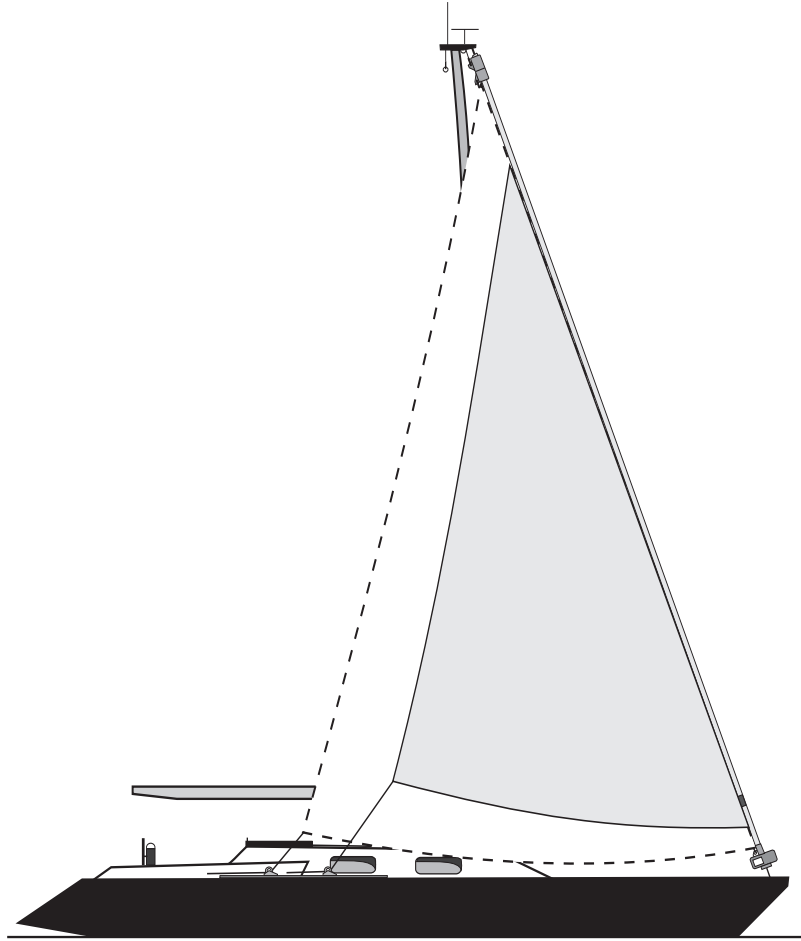

Telltails

Headsail trim is important to both the cruising sailor and the racing sailor, so have your sailmaker add telltales to the luff of each headsail. You can then fine tune your headsail shape by adjusting your lead position so that all the telltales along the luff lift at the same time. If the top telltale lifts first, move the lead forward; conversely if the lower telltale lifts first, move the lead aft.

Gaining Performance From Your Furling Headsail

The moment you reef a headsail you lose some of its design attributes, and if you view sail efficiency as part of overall seamanship – which you should – then finding ways to improve the performance of your headsail is important. An average headsail has the maximum draft located at a point about 33 to 38 percent aft from the luff. Therefore, as soon as you roll the sail up, even a little, you roll away the ideal shape and end up with a compromise. Furthermore, as the clew rises the center of effort gets higher as well, precisely at a time when you would prefer to have it lowered to reduce heeling moment. You cannot do much about this, but you can modify your deck layout to ensure that your genoa is trimmed properly and performing effectively.

Start with a sail that has the correct clew height and then modify your deck layout so that you can move the sheet lead position to accommodate clew location as the sail is reefed. Each sailmaker has his own idea of where to place the clew. Those with a racing bent like it low, whereas classic cruisers, for example, those with traditional-looking schooners or cutters, like it high. In the end it really depends on your sailing plans and the kind of boat you are sailing. For most cruisers the clew height should fall somewhere between the two extremes, since there are benefits to be gained from each. A low clew, for example, provides the best upwind performance since the shape is more consistent throughout the sail, the center of effort is lower and you have a short, sure sheeting point. On the down side, the moment you reef the sail, your sheeting position changes (Figure 7.8) and unless you have a way of adjusting the sheet lead, you quickly lose all performance.

With a high-clew sail, on the other hand, you can reef the sail and even without much adjustment to the lead position you will end up with a decent sheeting point. The problem is that high-clew sails are fairly inefficient for windward work, although they are fine for reaching and work well with a staysail. Again, it is a matter of preference. My ideal sail is one that has the clew high enough so that there is good visibility under the sail but low enough that the sail retains some of its performance ability. You also need to allow room for waves crashing over your bow to pass easily under the foot of the sail, and you need the clew low enough so that you can adjust the leech line without hanging over the lifelines.

If your deck layout does not already allow you to adjust the sheet lead position while under sail, modifying with modern deck hardware is a simple matter. Replace your car and track with one that can be adjusted under load, and add a line that runs from the front of the car forward to a turning block, and then aft to a winch. This allows you to drag the lead forward, or ease it aft. As soon as you reef your genoa, the clew travels forward. Sails with lower clews need a sheeting position adjusted sooner and more often. The same applies when you ease the sail out when sailing on a reach. If you do not move the lead forward the clew rides up and spills wind from the leech, depowering it and losing most of its efficiency. Having the ability to adjust the car position is crucial to overall performance.



Two systems for adjusting the lead position of a headsail, both using a simple block and tackle for moving the car.

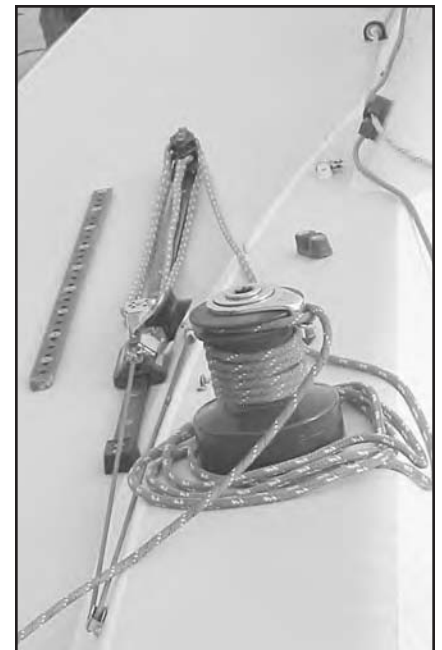

The headsail adjuster on the Reichel Pugh 70 Mojo worked perfectly, especially so because the clew of the headsail was fairly high off the deck.



A New Generation of Furling Headsails

We've discussed how new equipment developed for the racing market often trickles down to the cruising market, and a good example of this is the latest generation of furlers and furling headsails. In the 2002/03 Around Alone race a number of the competitors had new line-drive furling units for their headsails in which the luff rope inside the headsail doubled as the headstay. The weight savings was enormous and with a line-drive furler being used to furl the headsail, the whole unit was very simple. Line-drive was originally developed by Facnor, a French company, and is now available from other manufacturers like Profurl and Harken. A line-drive furler is essentially a large spool furling drum with a single endless line, in other words a loop. The large radius of the spool gives greater leverage to roll up big sails just as a larger sprocket on the rear wheel of a bike allows you to go uphill. They are simple to use, but fairly expensive. The key to the success of this system is the furling line that runs up the luff of the sail. New torque-resistant lines are being developed specifically for this type of application. The drawback of these systems is that these are furling units, not reefing units, and each sail is either completely rolled up or completely unfurled. Therefore, you need a number of different headsails each on its own line-drive furler in order to adapt your sailplan to the changing conditions. The foretriangle is a bit more cluttered, but for racing sailors who need to change gears often and quickly it's a good solution. Similar technology has been used for quite a while on small boats like the Melges 30 where the sail loads are less, and without highly engineered luff ropes the sail still furls quite easily.

There is much to think about when it comes to buying new sails and getting them to work properly on your boat. Like many things in life, you often have to make small compromises, but the key is an understanding of what all the components do and how they affect your sailplan. Ask yourself good questions and think carefully about your sailing ability and sailing plans before buying new sails. Getting exactly what you want is very satisfying and part of the overall fun of sailing.

Chapter 8

ALL ABOUT SPINNAKERS

Downwind Sails Explained

There is nothing quite like a day in the trades with a warm wind at your back and the horizon ahead stretched in a wide arc like open arms just waiting for you. You are romping downwind with every inch of sail set, your boat rollicking and revelling in the conditions. Unfortunately for many sailors this is not a reality. They are wobbling downwind wing-and-wing, or worse, with the engine on and the spinnaker neatly stowed in the sail locker. Sailing with a spinnaker should not be a scary thing. With a little practice it is not only easy to set, but capable of making sailing that much more fun.

Up to now this book has concentrated on the front-and-back sails: the main-sail and headsails. Now it's time to ease the sheets, feel the speed increase, and set the chute. Before we drag the sail out of its bag, however, we are going to look at the sail's history, construction, engineering, and design. The spinnakers of today are a far cry from the spinnakers of a few decades ago. They are more versatile, easier to set and douse, and much more fun to use. In this chapter we will learn all there is to know about these colorful sails, and by the time you have read the chapter on sail handling you should be an expert. If not an expert, then at the very least you will have a greater understanding and appreciation of the sail, and most important of all, you will no longer be afraid to set one, even in brisk winds.

A Brief History

Spinnakers have been around for almost 150 years. In fact, the early spinnakers were first used on the Solent, that storied strip of water between mainland England, and the Isle of Wight off the country's south coast. In the mid-1800s, dozens of yachts could be seen racing on the Solent, and the competition was as keen then as it's ever been. Any edge that could be gained might mean the difference between winning and losing, and sailors tried everything they knew to be competitive. While living in Cowes on the Isle of Wight in the late 1970s, I heard a theory that the first spinnaker was designed and built by a local sailmaker by the name of William Gordon. The sail was used on his yacht *Niobe*, and with it Gordon had many successes. The sail was made from cotton and was more like a fat-bellied genoa than the round spinnaker of today. In fact, the first spinnakers were asymmetrical. The story goes that when the sail was first set one of the crewmen commented that it was sure to make the boat "spin," or go fast in the language of the day. The sail was soon dubbed the spin-maker which later became spinnaker.

Spinnakers add fun and color to sailing.



A second theory, however, credits the origin of the name to Mr Gordon's archrival, a man by the name of Herbert Maudslay who owned a yacht called *Sphinx*. For a while these new sails were named after the boat names, with the one on Gordon's boat being called a "niobe," and the one on Maudslay's boat being called a "sphinx." Word has it that the crew bastardised the word sphinx to spinker, and eventually to spinnaker. I can't comment on the authenticity of either of these theories, but they are interesting stories none the less.

Different Panel Configurations

Although spinnakers remained a part the sailor's inventory through the late nineteenth and early twentieth centuries, it was only when nylon replaced cotton as the fabric of choice that spinnakers really came into their own. This is because nylon has a good strength-to-weight ratio, meaning it's not only light but strong, perfect for a sail that needs to float out and away from the rest of the sailplan. What it trades for this strength and lightness it gives up in stretch resistance, but for spinnakers that's not a bad thing. As noted in Chapter 2, nylon was first developed by the Du Pont company in late 1930s, and it was shortly thereafter that the most notable sailmaker of the day, Ratsey and Laphorn, used the fabric to build the first symmetrical spinnaker. The panel layout on this new type of sail consist-

CROSS-CUT SPINNAKER

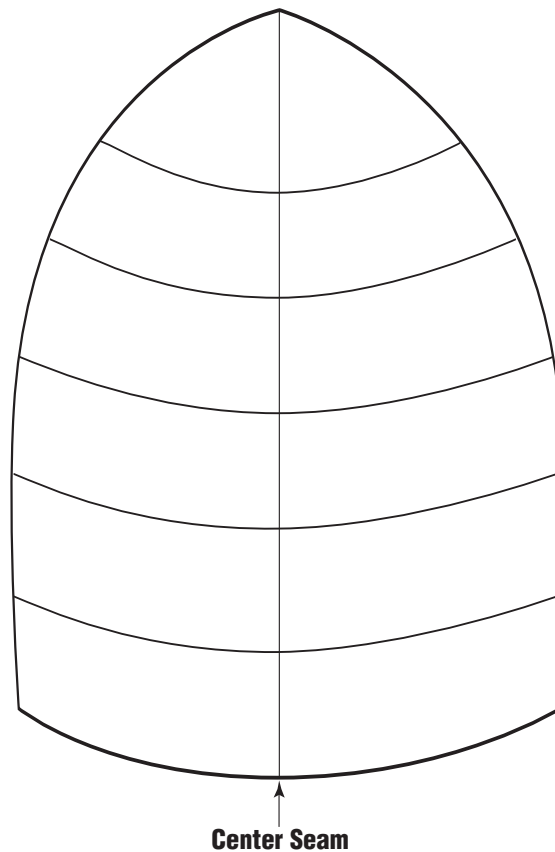

Figure 8.1

Having the panels run across the sail allowed Hood to introduce sail shape more consistently and, drawing from his experience building cross-cut headsails and mainsails, more precisely.

ed of a series of vertical panels working in from the leeches toward the center of the sail in diminishing sizes. While the sail worked well, it was only when Ted Hood turned the panel layout on its side and started to build cross-cut spinnakers that sail development began in earnest.

Because of the way the panels ran from the clews to the head of the sail, the Ratsey and Lapthorn sail was triangular in shape, like an “A.” But Ted Hood believed that a sail that had more projected area, especially up high, would perform better, and so he built his sail with cross-cut panels, which meant there was no practical limit to how wide the sail could be across the head. With this new flexibility, Hood began experimenting with different size sails, until he eventually found a balance between too little projected area and a sail that would fly without its edges being so large and heavy that they collapsed in on the center. Having the panels run across the sail also allowed him to introduce sail shape more consistently and, drawing from his experience building cross-cut headsails and mainsails, more precisely (Figure 8.1).

Unfortunately, although cross-cut panels worked quite well through the middle sections of the sail, in the top third there were serious problems. Most significantly, where the edges curved in toward the head of the sail, the fabric was cut on a huge bias causing it to stretch and distort to the point where it was no longer able to support the shoulders of the spinnaker. Hood Sails was the first sailmaker to put a radial head on a cross-cut body to address the problems caused by the cross-cut panels (Figure 8.2). And afterward, North Sails, seeing this improve-

CROSS-CUT RADIAL SPINNAKER

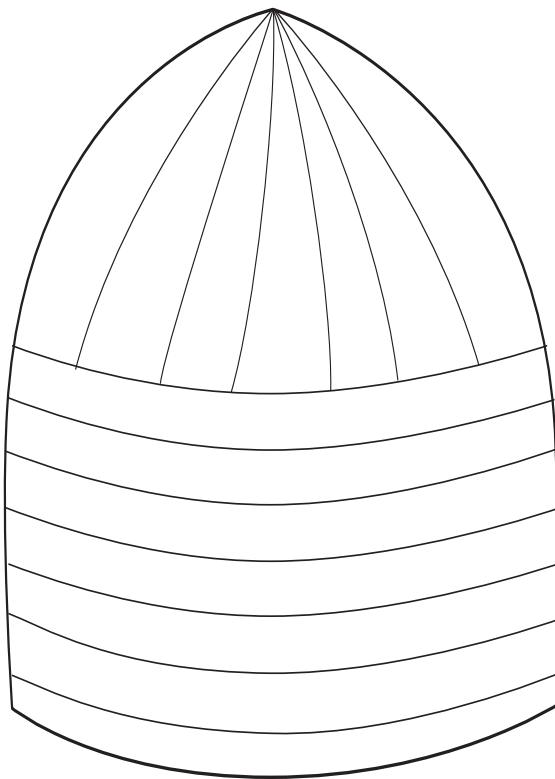

Figure 8.2

In the cross-cut radial spinnaker, a radial head on a cross-cut body addressed the problems caused by the cross-cut panels.



The tri-radial spinnaker revolutionized spinnaker design by allowing for more stable sail shapes.

ment in the head, reasoned that the clews could also benefit from being radial. This resulted in what became a true benchmark sail: the tri-radial spinnaker (Figure 8.3).

Despite the obvious advantages of a tri-radial spinnaker, sailmakers eventually became keen to create a sail that had a more uniform transition of fabric strength along load lines, which meant getting rid of the cross-cut panels in the center. Just as you would not expect to see horizontal panels on a radial headsail, sailmakers reasoned that there should not be horizontal panels on radial spinnakers and set about designing and engineering a new generation of spinnakers with panels oriented along expected load paths and the fabric making a turn at each horizontal seam (Figure 8.4). Spinnaker nylon is generally warp-oriented, meaning its strength runs the length of the fabric, so to use the fabric effectively the sailmaker needs to cut small panels and piece them together so that the warp yarns run along the load

paths. The smaller the panels, the more accurate the orientation, although there is always the trade-off between the expense of making a sail with an infinite number of panels and one that has a reasonable amount of panels.

TRI-RADIAL SPINNAKER

Figure 8.3

Building on the technology of the cross-cut radial spinnakers, tri-radial spinnakers were developed.

MODERN SPINNAKERS

Instead of horizontal seams with the load running across the fill (less strength), the panels are turned to take the load.

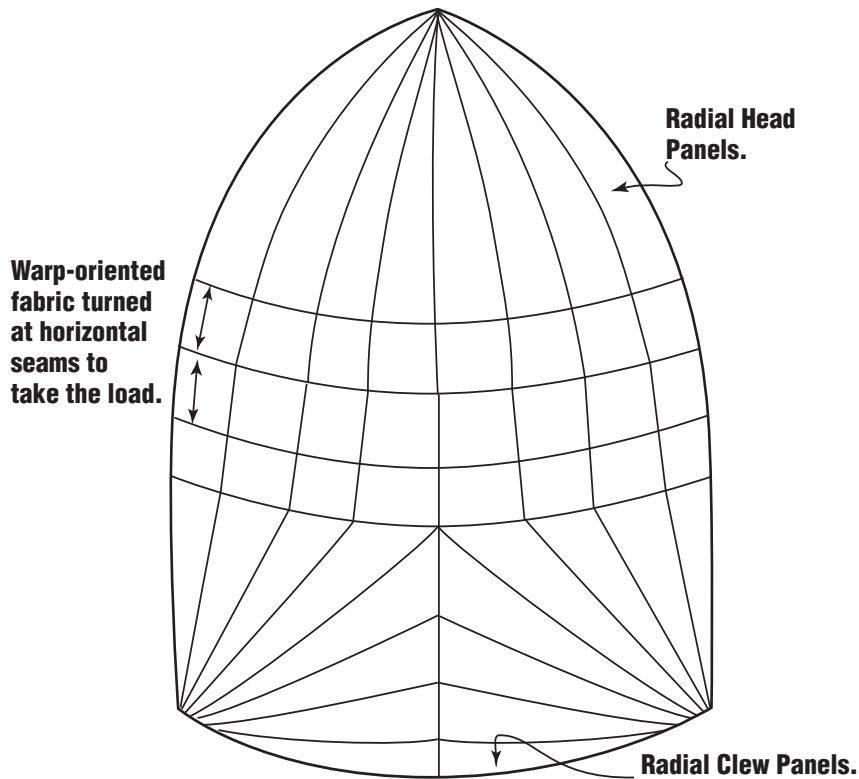

Figure 8.4

To remove horizontal panels from radial spinnakers, a new generation of spinnakers with panels oriented along expected load paths were created.

Modern spinnaker designs are becoming more complex with panels changing direction to match the loads in the sail.

Spinnaker Fabrics

While the advances in spinnaker fabrics have not been as dramatic as we have seen in the fabric for working sails, there have in fact been some subtle improvements, mostly in terms of finish. Nylons are not set with as much heat so there is quite a bit of bias stretch, but ever since fabric makers started to weave warp-oriented nylons specifically for tri-radial sails, this bias stretch has not been as much of a problem. Spinnaker nylon comes in a number of weights including 0.5 ounce, 0.75 ounce, 1.5 ounces, and 2.2 ounces. The actual finished cloth weighs about a quarter ounce more than these designations.

For spinnakers that are used for reaching where there is still quite a bit of attached flow, low stretch and an aerodynamic shape are important and sailmakers have been using laminate scrim and light Cuben Fiber. These fabrics are relatively heavy, but the trade-off between low stretch and extra weight is a reasonable one, especially on a reach.

This is fine for light spinnakers. Once you get into heavy-air sails, however, the fabric needs to have some give. A spinnaker that collapses and refills does so with a large amount of shock loading, and that load has to go somewhere. It's better that it be



absorbed by the fabric than transmitted onto the sheets, halyard, and mast where it could possibly do some real damage. Light-air reaching sails are less likely to collapse and refill, so stretch resistance is key to good shape retention and speed. As soon as you bear away onto a reach or run, the apparent wind drops, and loads on sails are dramatically reduced. The loads on the body of a spinnaker with the wind from behind are fairly minimal, and therefore stretch resistance can be traded for give in the fabric that will absorb shock loads.

Symmetrical Versus Asymmetrical Spinnakers

Even though the first spinnakers were in fact asymmetrical, they were quickly replaced by symmetrical spinnakers, and that's the kind of sail that became popular and recognized on sailboats all over the world. To clarify the difference: A symmetrical spinnaker is just that. Both sides of the sail are symmetrical in shape and geometry. This symmetry is divided by the center seam that runs from the head of the sail down to the mid-point of the foot. An asymmetrical spinnaker, on the other hand, looks like a cross between a regular spinnaker and a large headsail (Figure 8.5). The luff is quite a bit longer than the leech, and the body of the sail has most of its shape about 35- to 40-percent aft from the luff with the back end relatively flat. Because asymmetrical spinnakers are easier to fly, perform better in almost all conditions except dead downwind, and are easier to manage, they are steadily gaining in popularity. For now though, symmetrical spinnakers are still more common.

ASYMMETRICAL SPINNAKER

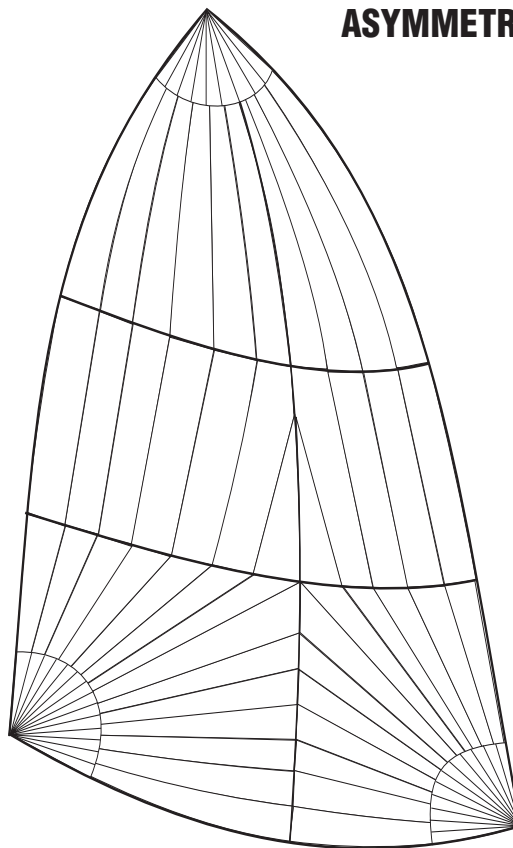

Figure 8.5

An asymmetrical spinnaker looks like a cross between a regular spinnaker and a large headsail.



Asymmetrical spinnakers have changed the way many sailors view spinnakers. They are much easier to use and add more fun and excitement to their sailing.

Spinnakers for the Cruising Sailor

It's not in a cruising sailor's nature to want to trim and change spinnakers constantly. A cruising sailor is more inclined to set the sail, set the autopilot and pull out a good book. With this in mind, let's look at the options available for cruisers. It begins by looking at the type of boat and sailing plans.

For example, if you have a boat like a Bristol 42 and you daysail out of Block Island, a single, all-purpose spinnaker built from 0.75-ounce fabric will more than suit your needs. The sail can be either symmetrical or asymmetrical, although if you do not already have spinnaker gear like a pole, afterguys, and sheets, I would recommend going with an asymmetrical sail because of the advantages mentioned above.

On the other hand, if you have a Quest 39 and plan to sail to the Caribbean with your wife and two kids, then you might consider more than one downwind sail, including a reaching spinnaker and a running spinnaker, since the Quest is a lively boat that will respond favorably to the different sails. A reaching spinnaker for this boat will be flatter than the runner, and if it's asymmetric it will have a shape that's conducive to sailing with the wind on the beam. A 0.75-ounce fabric will be suitable. The running spinnaker can be either symmetrical or asymmetric: if you are going to be sailing in the trades then setting the symmetric spinnaker on a pole will be worth the effort; if you are in a situation where the sail will only be used for short periods at a time, consider the asymmetric. As we will learn later in this chapter, it's much easier to set and douse an asymmetric but it's not always a better-performing sail. It really depends on the wind angle.

Spinnaker design is a complex procedure that can result in sails with very narrow or very broad wind ranges. Everything depends on the requirements of the sailor. Flat sails are good for reaching, but when used for running they have a tendency to collapse since there is insufficient camber to support the flat edges and keep the sail flying. On the other hand, a deep, round sail perfect for running will only serve to drag the boat sideways when used on a reach. Sailmakers will custom design a spinnaker to accommodate a sailor's skill level, the displacement of the boat (light boats accelerate quicker than heavy ones, and if the sail is not carefully trimmed it may collapse), and the number of other sails in the inventory.

A reaching spinnaker can be used between an apparent wind angle of 70 and 110 degrees, and a running spinnaker can be used at an apparent wind angle of between 105 and 160 degrees. The reaching sail will be reinforced to accept shock loads if the sail collapses (as it tends to if left unattended), while the running sail will be built as light as possible to allow it to fly easily. The reaching sail acts more like a normal airfoil creating aerodynamic lift, whereas the running spinnaker is only about drag. The all-purpose is a compromise between the two.

The Theory

There is a lot more to the theory of how spinnakers work than simply projecting sail area in the way of wind and getting shoved along by it, especially when on a reach. Just like working sails, spinnakers have an attached flow that blows both across and down the sail on different points of sail. Understanding this attached flow will give you more insight into how a boat sails and allow you to fly your spinnaker more effectively, no matter what the point of sail.

Let's begin by looking at the flow over a spinnaker when the boat is sailing with the wind on the beam. As can be seen in Figure 8.6., the spinnaker is very similar to an oversized, somewhat inefficient headsail. The wind is attempting to

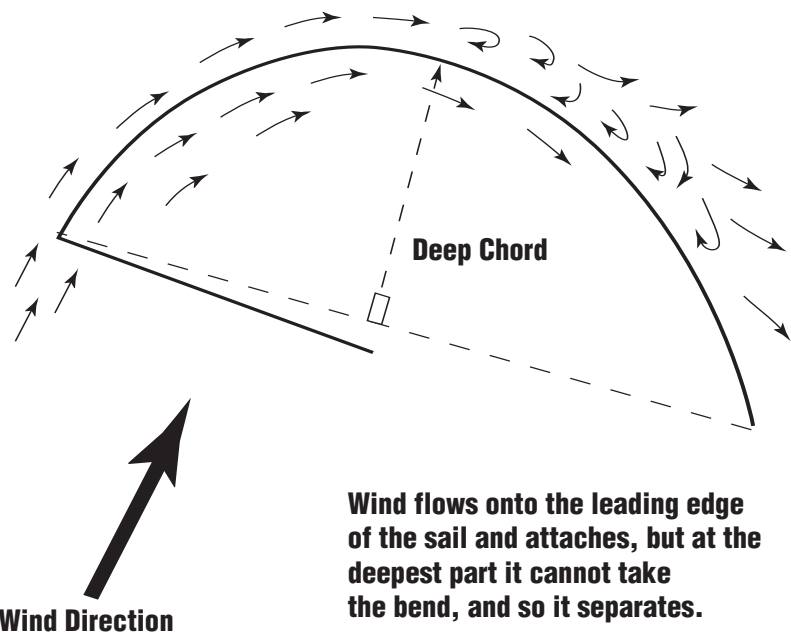

Figure 8.6

The spinnaker is very similar to an oversized, somewhat inefficient headsail. The wind is attempting to attach to the sail on both sides, but because of the large chord depth, the wind has a hard time making the turn, so for the second half of its journey across the spinnaker it is separated from the surface.

attach to the sail on both sides, but because of the large chord depth of the spinnaker, the wind has a hard time making the turn, so for the second half of its journey across the spinnaker it is separated from the surface. This separated air causes the sail to drag the boat sideways rather than to provide lift, and if the sailor is trying to carry the spinnaker too close to the wind, the result will be massive leeway and very little lift. Therefore, the flatter the spinnaker, the more efficient it will be for reaching. You might even wonder why it's worth setting the spinnaker in the first place when it's such an inefficient sail for reaching. The reason is that the large increase in sail area still helps with boat speed unless you are trying to carry it too close to the wind and going sideways. Again, like many things in sailing, it's a delicate balance. Note that some of the wind's energy is being used simply to lift and fill the sail so the rest can be translated into boat speed. For this reason, as we will learn under sail trim, bigger is not always better, especially in light winds, since getting a sail to lift and fly away from the disturbed air at the back of the mainsail is key to good spinnaker trim.

As the wind comes aft, air still continues to flow across the sail, but now the amount of projected area becomes a bigger factor than attached flow. As shown in Figure 8.6, the elliptical shape of a spinnaker is hardly an efficient foil for providing lift, but once the wind comes aft that inefficiency becomes less of an issue. At some point the spinnaker is squared so far aft that it is no longer affected by the dead air in the lee of the mainsail. The point at which this happens differs from boat to boat, but usually around an apparent wind angle of 110 degrees for masthead sails, and 120 degrees for fractional sails, the spinnaker is working on its own, clear of the mainsail. This is the point where wind begins to enter the spinnaker from both sides and flow toward the center of the sail causing a pocket of dead air in the middle. This dead air is forced down and out the bottom of the sail by new air being sucked in at the edges. When you are running downwind with a spinnaker set you can often see the water below the sail rippling from the downdrafts of air. When the boat is sailing dead downwind there is no attachment on the leeward side of the sail. The angle at which the wind hits the edges of the sail is so abrupt that it cannot gain a hold on the surface, and it spins in a vacuum in a series of small vortices.

Using Symmetrical and Asymmetrical Spinnakers

One advantage of asymmetrical spinnakers is that they are often much easier to set and douse when under sail. Conventional spinnakers can be fairly complicated to use requiring a number of different sheets and guys attached to the sail, to say nothing of a spinnaker pole that has its own topping lift to hold the outboard end of the pole up and downhaul to hold the outboard end down. It's no wonder the sail can sometimes be intimidating. In the chapter on sail handling we will discuss some basic ways to manage spinnakers as well as some innovative ways to get a spinnaker down, especially when the wind is freshening.

The asymmetrical spinnaker, on the other hand, is in many ways a far more practical and efficient sail since it is usually not set with a spinnaker pole but simply tacked to the bow of the boat or to a bowsprit from which it is then hoisted

“... some of the wind's energy is being used simply to lift and fill the sail so the rest can be translated into boat speed.”

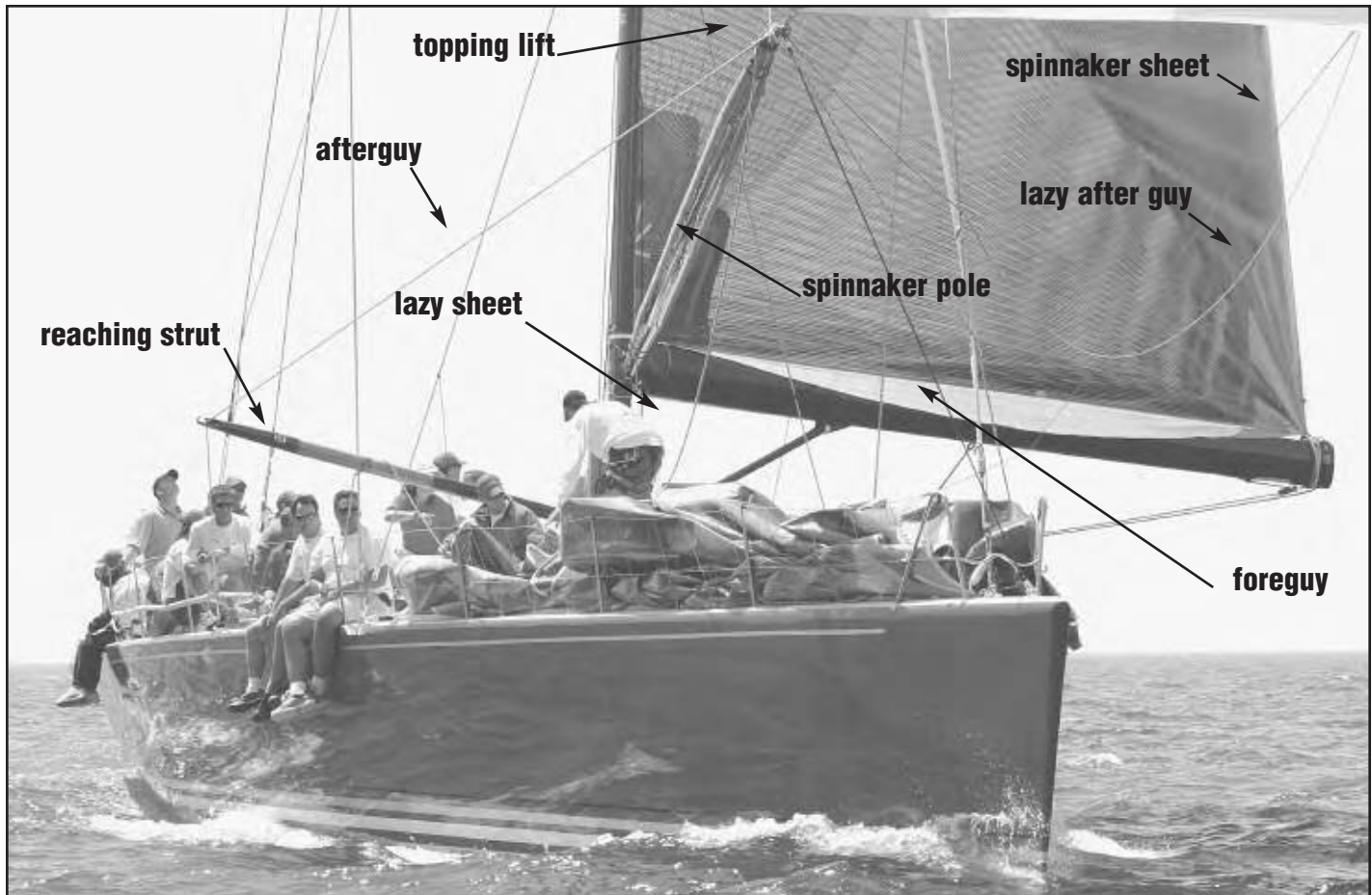

Conventional spinnakers can be fairly complicated to use requiring a number of different sheets and guys attached to the sail, to say nothing of a spinnaker pole that has its own topping lift to hold the outboard end of the pole up and downhaul to hold the outboard end down.

with a spinnaker halyard. By omitting the pole projecting off the mast, the process of setting and dousing the spinnaker is greatly simplified, and the sail becomes more manageable. Note that if your boat has a bowsprit, the sail will work that much better since the sprit gets the sail out and away from the dead air behind the mainsail. The leech of the sail is usually quite a bit shorter than the luff, and the shape of the sail is vastly different than that of a conventional symmetrical spinnaker. The asymmetrical spinnaker also has a much more efficient shape for reaching (Figure 8.7). The wind is able to remain attached all the way across the sail providing drive as well as lift.

An asymmetrical spinnaker does have some drawbacks when compared to a conventional spinnaker and this has to do with jibing and rotating the sail aft once the wind comes from behind. Because symmetrical spinnakers are just that – symmetrical – they can be easily jibed with the old clew becoming the new tack and vice versa. But it's a different story with an asymmetrical spinnaker. Jibing means either dropping the sail, changing the sheets, and resetting the sail on the other jibe, or performing a complex maneuver that involves floating the sail around the front of the headstay and dragging the clew, foot, and leech aft, a little like jibing a genoa with a second forestay or babystay in the way. Asymmetricals tacked to the bow or a bowsprit are also less efficient when sailing on a broad reach or dead run since there is no way to rotate the tack of the sail to windward as is the case with a spinnaker on a conventional pole. As a

ASYMMETRIC SPINNAKER

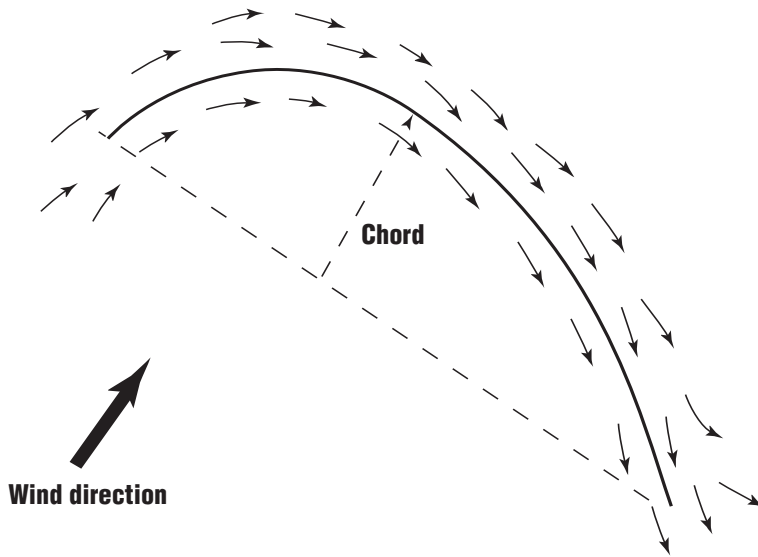

Wind flows across an asymmetric spinnaker more like a large, full headsail making it good for reaching.

Figure 8.7

The asymmetrical spinnaker has an efficient shape for reaching. The wind is able to remain attached all the way across the sail, providing drive as well as lift.

result, there's no way to get the sail out of the dead air to leeward of the main. Most sailors agree, however, that the performance gains of an asymmetrical spinnaker far outweigh the inconvenience.

Ultimately, those sailors who spend weeks in the Trade Winds may prefer the symmetrical spinnaker, since they can enjoy days of fabulous downwind sailing for their one-time effort of setting the sail. Sailors out for an evening sail, however, might not want to bother with the pole, sheets, and guys, and for them the asymmetrical spinnaker is much more practical.

Spinnakers by the Numbers

Spinnakers have gone under countless names since the days of *Niobe* and *Sphinx*, but sailmakers started numbering spinnakers in earnest in 1998 with the development of a top-secret sail built for the Whitbread Round the World Race. Like most secret operations the sail was given a name reminiscent of something the CIA might have conjured up. Specifically, the sail was called a "Code 0." Building on from the Code 0 are a number of other Code sails, a description of which is included below. In this particular example the even-numbered sails are for broad reaching and running. The higher the number, the more wind it is designed for.

Code 0

The Code 0 was originally developed for the Whitbread Race where a restriction on the Whitbread 60 rule limited the size of the head-

The Code 0 on this trimaran works well on a number of points of sail.



“Because this sail is a hybrid between a spinnaker and genoa, tending more toward the headsail, it generates headsail-type loads.”

sails. Because the boats were fractionally rigged they lacked power in the foretriangle, especially in light winds, and sailmakers were looking for a way to add some power without breaking any rules. They needed a sail that could perform like a headsail, in other words it could be used for sailing to windward, but one that was measured as a spinnaker. In order to be considered a spinnaker the sail had to have a mid-girth of at least 75 percent of the length of the foot. The mid-girth is the dimension from the mid-point of the luff across the sail to the mid-point of the leech. By creating a sail that looked like a headsail with a positive roach, the sail designers ended up with a sail that could be carried at very close wind angles while still being able to fly like an asymmetrical spinnaker when the wind came aft. Best of all it was measured as a spinnaker, not a headsail. Code 0 sails are actually closer to a giant headsail than they are to a spinnaker, and boats with small, non-overlapping jibs or fractional genoas will see the most benefit from a Code 0 because they are the boats that traditionally lack power in the foretriangle. Boats with masthead rigs and large 155-percent genoas will see the least performance benefit, but since the sail is easy to set and douse they should definitely be considered by all sailors.

One of the difficulties with Code 0 design is to come up with a shape that allows the sail to be used at fairly narrow wind angles. A flat sail is needed, but not so flat that there is insufficient camber to support the positive roach without flapping. The luff length is determined by the rig configuration and is usually as long as possible, running from the top of the mast to the end of the bowsprit (if there is one), or to the bow of the boat. The foot length is around half the luff length depending on the design of the boat. Since the Code 0 is a hybrid between a genoa and a spinnaker, it is usually made from a fabric that is also halfway between the two. A light film-to-film polyester scrim or Cuben Fiber works really well. The fabric needs to be light enough so that the sail will fly, yet tough enough to take the loads without distorting. Code 0 sails are usually set on line-drive furlers, since the sails are flat enough that they can be rolled away and easily stowed. Failing that, the sail can be set in yarn stops; in other words it can be bundled up lengthwise and tied with yarn so that when the sail is hoisted it won't fill until the crew is ready, at which point a light tug on the clew breaks the yarns and the sail fills with air. The sail is dropped the same way as you would a spinnaker. A final feature of the sail that enhances its performance is a low-stretch line like Vectran or Kevlar in the luff. This allows the sails to be wound up tight to prevent sag, something that is important when sailing close to the wind. Depending upon the fabric and boat design, the Code 0 can be carried from as close as 45 degrees apparent wind angle (AWA), to as wide as 75 to 80 degrees. At this point, however, other sails are more efficient.

A final point about the Code 0: Because this sail is a hybrid between a spinnaker and genoa, tending more toward the headsail, it generates headsail-type loads. If the sail is going to be set from a bowsprit, be sure that the bowsprit is strong enough to manage the loads, since usually bowsprits are engineered to handle the more benign loads of spinnakers. The same applies to your mast. The

amount of halyard tension required to keep the luff from sagging places a large compression load on the mast for which it may not have been engineered. Often mast manufacturers will require a 2:1 halyard for the Code 0 to minimize mast compression. In sum, this is a powerful sail and should be treated accordingly.

Code 1

This sail is usually the first to take over from the Code 0 and is a specialized sail designed to fill the gap for when the winds are at an apparent wind angle of between 70 and 120 degrees off the bow. This sail closely resembles the asymmetrical reaching spinnaker used by most cruisers. Made from nylon, the Code 1 is a light, versatile spinnaker that can be set and doused with a spinnaker sock if cruising, or in yarn stops if racing. It is usually shorter on the foot than an all-purpose asymmetrical spinnaker and has flatter chord sections to allow it to be carried closer to the wind. Again, depending upon the design of the boat and the number of other sails in the inventory, this sail will usually be made from a fairly light nylon, reinforced along the leech and with oversized corner patches to take the increased load experienced when reaching.

Code 2

The Code 2 is a light-air, running spinnaker with a wind range between 105 and 155 degrees AWA. Larger and lighter than the Code 1, this sail has a lot more chord depth for the broader wind angles. It's an ideal sail for a cruising sailor who is used to starting the engine when the wind gets light. It's easy to set and douse with a sock, or with stops if the sail is part of a racing inventory.

Code 3

Similar in design to the Code 1, but built from a heavier fabric, the Code 3 has a wind range of 75 to 130 degrees AWA. This sail is useful for racing boats with crew weight on the rail or water ballast, or for cruising boats with a high righting

ASYMMETRIC:

- CODE 1A**
Light Reach/
VMG Run
70±120 AWA
- CODE 2A**
Light Runner
110±120 AWA
- CODE 3A**
Medium Reacher
70±120 AWA
- CODE 4A**
Medium Runner
110±150 AWA
- CODE 5A**
Heavy Reacher
95±130 AWA

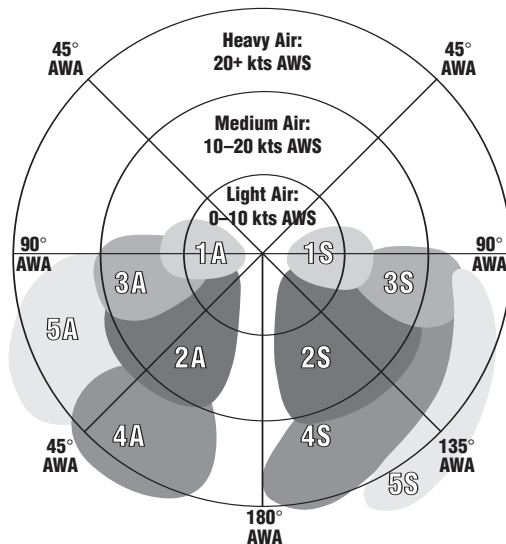

SYMMETRIC:

- CODE 1S**
Light Reach/
VMG Run
65±95 AWA
- CODE 2S**
Light/Medium Runner
120±150 AWA
- CODE 3S**
Medium Reacher
75±130 AWA
- CODE 4S**
Deep Running
130±180 AWA
- CODE 5S**
Storm Spinnaker

Figure 8.8
Spinnaker code numbering used by North Sails.



The Code 5 on Tim Kent's Open 50 Everest Horizontal was one of the most used sails in his inventory when he sailed around the world.

moment. For most cruising sailors, a heavy reaching spinnaker like the Code 3 is not practical. The sail can unduly load the mast and rigging, and if not trimmed properly, can drag the boat sideways as much as forward.

Code 4

This sail most closely resembles the asymmetrical spinnaker found on many cruising boats. As an even-numbered sail it is used for running, and its high number indicates that it can be used in stronger winds. If the Code 4 is part of a racing inventory, the shape will be narrowly defined to fit between the other spinnakers on board, while as a cruising sail it will be more forgiving. The Code 4 has a wind range between 105 and 155 degrees AWA.

Code 5

This is a specialized sail for heavy-air reaching, and like the Code 3 is specifically a racing sail. Smaller in size than the other spinnakers, it is strong and forgiving. The Code 5 can be used between 100 and 140 degrees AWA.

Again, the Code numbering system applies to both asymmetrical and symmetrical spinnakers, and is described here to show how different sails are designed to meet different needs and conditions. Some sailmakers will have their own system, and nothing is cast in stone. These are broad references only and the individual sails will be tailored to suit each particular boat. Sail designers take into

account the aspect ratio of the rig, the righting moment of the boat, class rules that restrict or limit the number of sails, and many other criteria. See Figure 8.8 on page 137 for the spinnaker code numbering system used by North Sails.

Between this chapter on spinnakers and future chapters where you will learn in more detail how to handle and trim spinnakers, you should have a better understanding of these sails, and after a little practice find them a lot less intimidating. Spinnakers can add so much enjoyment to your sailing that it's well worth the effort to study and learn how to use them.

Chapter 9

STORM SAILS

Techniques, Tips, and Some Lessons Learned

Few sails in any sailor's inventory are as neglected, controversial, or ultimately important as storm sails. These generally consist of a trysail, i.e., a kind of mini-mainsail bent on the mast after the regular main has been lashed to the boom, and a storm jib, a tiny scrap of sail flown either from the forestay or an inner forestay in place of a standard jib. In both cases these sails are made to withstand gale-force winds and an occasional knockdown. They should also be bright orange so that they are highly visible. You can have them manufactured out of special orange Dacron, or you can have your sails painted with a florescent paint.

The Storm Jib

A storm jib must be engineered and built for extreme conditions. It usually has a high clew and no foot round so the waves crashing over the foredeck will be able to pass easily under the sail (Figure 9.1 on page 140). The fabric must be heavy enough to withstand not only the loads imposed on it by gusts, but more importantly, the flogging that occurs when the sail is set. For boats 30 to 40 feet in length, the fabric should be a woven Dacron weighing no less than 10 ounces. For boats above 40 feet the fabric should be at least 12 ounces or even 14 ounces. A well-built storm jib should have reinforcement patches sewn behind each hank, since when it is being hoisted a lot of point-loading occurs at each hank and without a reinforcement patch these areas could be potential

Storm sails on board Bobst Group Armor lux as Bernard Stamm sails into New Zealand at the end of Leg 3 of the 2002/03 Around Alone race.



Photo by Roy Riley, Marinepics

Figure 9.1

A storm jib must be engineered and built for extreme conditions – typically with a high clew and no foot round so the waves crashing over the foredeck will be able to pass easily under the sail.

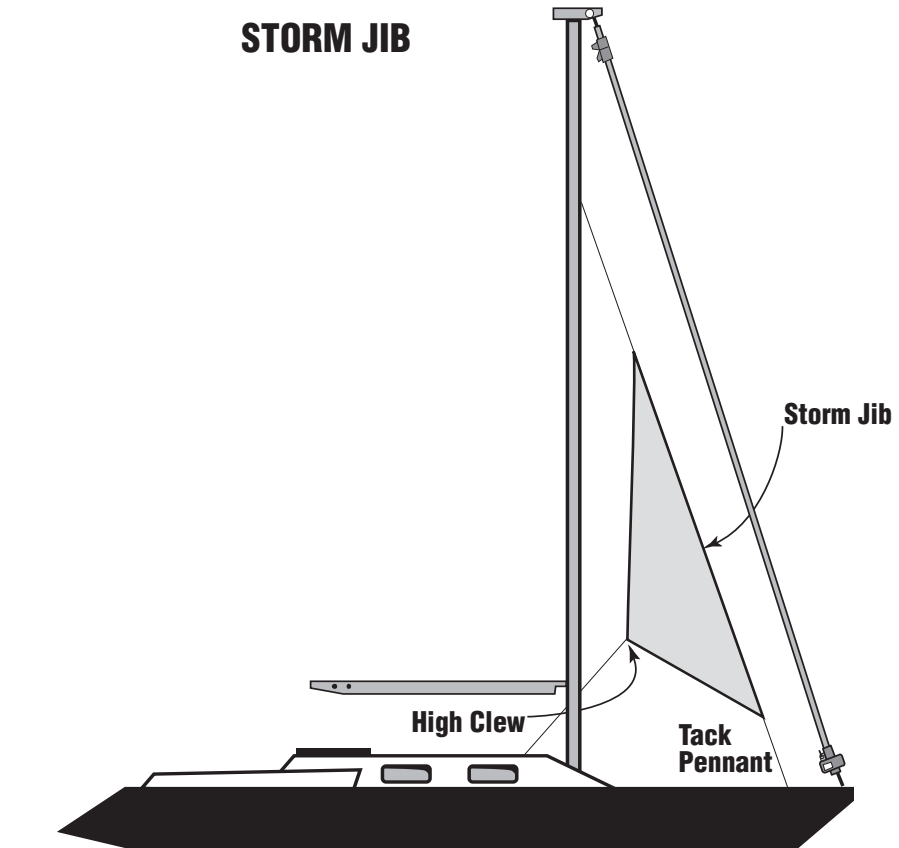

weak spots. A storm jib should also have oversized corner reinforcement patches and a set of sheets permanently spliced to the clew to avoid having to search for strong sheets at a time when you need to concentrate on other matters. You should also splice a short strop at the tack to make sure that the entire sail is raised up off the deck allowing waves crashing over the foredeck that much more room to pass easily under the sail. Waves cause as much, if not more, damage in extreme weather as wind.

Under no circumstances should you consider cutting down an old sail to make a storm jib. Likewise you should not attempt to ride out a storm with a rolled-up headsail. In both of these cases the sail will not be strong enough for gale-force conditions. Storm jibs can be set on either the forestay or the inner forestay, and it's my recommendation that it be set on the latter with hanks rather than a furling unit or bolt rope system. This is because when the wind is up you need to bring the center of effort of your sailplan more in toward the center of the boat. Setting the sail on the headstay will have the opposite effect. Setting it closer to the mast will improve the way the boat manages the conditions.

As for simply reefing a roller-furling headsail instead of setting a specially designed storm jib on hanks, the same points that were outlined in Chapter 7 apply, only more so, namely:

- Hanks are reliable.
- The storm sail will have a flat chord depth specific for the conditions.
- The location of maximum draft in the storm sail will be correct.

Indeed, I find it astonishing that some well-meaning sailmakers are still telling sailors that they can use their heavily-reefed headsail as a storm sail. There are a number of things wrong with that assumption.

- As we learned in Chapter 7 the amount of engineering that would need to go into a headsail to have it fly properly in moderate conditions while still being strong enough to withstand gale-force conditions, is impractical.
- Relying on a furling line to keep the sail reefed, or some kind of pin device to do the same is unsafe. There is an immense amount of torque on the furling unit and gale-force conditions only add to this torque. Furling lines break with alarming regularity and having to deal with fixing a pin on the bow of the boat when a storm is rising is unseamanlike at best.
- When it comes time to set the storm sail, you are not going to unroll the headsail and drop it. It's simply impossible, especially if you are like most of us—a bit in denial about the impending increase in wind strength until it's too late to safely set the storm jib.
- It's very difficult to hoist a storm jib with a luff tape or bolt rope, since it requires a person at the bow to feed the tape inch-by-inch into the groove, and someone to wind the halyard – an unsafe solution at best.

Note that the above points assume you are sailing on a larger boat or a boat that has room for an inner forestay. Small boats are a little different. If you only have a single headstay you might just have to sail with a heavily reefed headsail or change sails as a storm approaches. Fortunately, changing sails is not quite as difficult on a small boat.

Gale Sail

There is also a solution called a Gale Sail, a viable alternative for any boat that either does not have an inner forestay, or has a roller-furling headsail on the inner forestay. The Gale Sail is a storm jib with a luff that wraps around a rolled-up sail. In fact, it sets over the sail, either the one on the inner forestay, if you have one, or one on the forestay, so that you can leave the headsail rolled up where it is. The Gale Sail is designed and engineered to take the abuse of storm conditions and is fairly easy to set with a Dacron luff flap that is fastened back on itself with large piston hanks. You need a spare halyard for hoisting it, but once attached it slides up over the regular sail quite easily. Dacron is actually a fairly slippery material (ever tried walking over a flaked sail on your foredeck and slipped?) as are most other fabrics, and once you have the hanks attached you can hoist the sail just as easily as a regular storm jib. It's a good product that goes a long way toward having a specific storm jib for storm conditions.

The Gale Sail slides over a rolled up headsail and is an effective storm jib.



Snapped Furling Line

In the early 1990s I sailed a plush 50-foot cruising boat across the Atlantic from Cowes, England, to Miami, Florida. The boat was not brand new, but it had been well maintained, or so I thought. Crossing the Bay of Biscay we ran into some snotty weather, and I learned a valuable lesson: Never rely on furling lines. As the storm approached, and before we were able to roll the headsail away and set a storm jib, the partially reefed headsail completely unrolled itself when the furling line snapped, so that instead of taking off sail, we suddenly had way too much sail up. Our only option was to drop the sail on the foredeck since without the furling line we could not reef it. With only a small crew it was a big job, but finally the sail was under control. A few days later we stopped in the Azores for a little R&R, and I took the opportunity to ask a number of sailors about their furling lines. To a man (and woman) they admitted to rarely, if ever, changing the furling line as part of their ongoing maintenance, and that only once a line had snapped did it occur to them to replace it with a new one. If you think about it, this is nothing less than absurd. We pack our sails in bags and add UV sunshields along the leech and foot of headsails to protect them from the sun, but we never think about the furling line baking in the tropical heat and slowly rotting. Just as you change the batteries in your smoke detector on your mother-in-law's birthday, so should you change the furling line on your roller-furling units with equal regularity.

STORM TRYSAIL

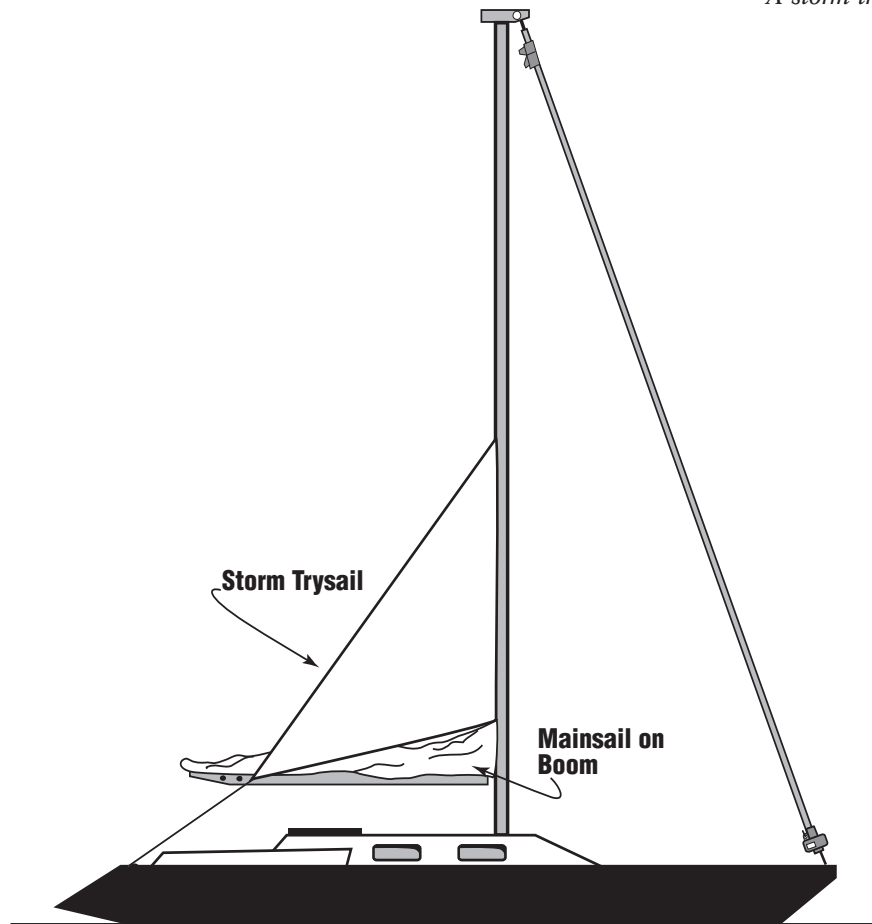

Figure 9.2
A storm trysail.

The Storm Trysail

The second part of the storm sail equation is the storm trysail (Figure 9.2). This sail is more for balancing the boat rather than driving it forward, since in gale-force conditions you need to be sure that you have some control over how the boat lies relative to the waves. It's an important sail, but in my opinion not as important as the storm jib, as I'll explain a little later.

As with the storm jib, the trysail needs to be built and engineered for the conditions and should not be an old sail that has been cut down. The same fabric weights apply as for the storm jib, as do the oversized corner reinforcement patches. And if the sail has slides, there must be adequate reinforcement at each slide to handle the point loading.

Again, this sail should not be confused with a performance sail. A trysail is a balancing sail without any of the potential problem areas a regular mainsail might have like battens and batten pockets. Virtually all rating rules call for a storm trysail to have a maximum area no larger than the result of the formula: $0.175 \times P$ (mainsail luff) $\times E$ (mainsail foot), with a hollowed-out leech and foot, the area will be roughly 25 to 30 percent that of the mainsail. This is a good, proven size for all boats, both racing and cruising.

A Separate Trysail Track

Many offshore sailors insist on a separate trysail track running up the trailing edge of the mast, and I tend to agree with them, especially aboard larger vessels. For a racing boat where weight and windage are a consideration, however, sharing the track with the mainsail is acceptable, providing there is a simple and secure way of loading the trysail's slides without having to remove the mainsail. Boats below 30 feet in length do not need a separate trysail track. The sails are a manageable size and changing from a mainsail to a trysail is not a long, complicated procedure. If your boat does not have a trysail track and you are heading offshore, they are fairly easy to install but be sure to talk to the mast manufacturer before you do so.

You need to consider two things when setting the storm trysail. First, you do not want to have to remove the mainsail from the mast. With a bolt rope you have no choice and you need to take every bit of care to ensure that the sail does not get away from you when it is lowered. If the main has slides, lower the sail and make sure there is a "gate" well above the top slide that can be opened easily to accept the storm trysail slides. The gate must be well above the top slide because in storm conditions it's very difficult to get the slides to stack neatly. Chances are there will be gaps between them, and you do not want to have to deal with this issue when waves are breaking over the deck.

Second, consider the height of the gate and its accessibility. It's dangerous and unseamanlike to be hanging onto a mast trying to feed slides into a gate. This may appear easy when the boat is tied to the dock, but when the wind is up and howling, it's very different. If you can't reach the gate, consider either a step on the mast (either side) or a separate track that runs down to a height that is easily accessible.

Once the trysail is attached to the mast, it is hoisted with a short pennant at the tack. This allows the sail to set above the mainsail, which is lashed to the boom. Like the storm jib, the trysail should be set with its own sheets permanently attached at the clew. It's important to note that these sheets should be run to a reinforced pad eye on deck or a snatch block on the rail, as opposed to the boom, which should be secured to the deck or in its own gallows if the boat has them. Make sure that the strop at the tack allows the sail to be sheeted correctly. Only a "dry run" will allow you to check this and to mark the sheets and strop with reference marks.

Many sailors insist not only on having a separate trysail track that runs all the way to the deck, but on having the trysail permanently attached to the track. In other words, load the slides and leave the sail in its bag at the base of the mast. While I commend this nod to good seamanship, I think this measure is a bit extreme. I have sailed well over 200,000 miles and only had occasion to use a trysail three times. The rest of the time the sail would have been in the way, possibly rotting in the sun. My call would be to stow the sail somewhere accessible and then bring it up on deck only when rough weather is forecast.

Carry Out a Dry Run

Again, I would encourage any crew planning an offshore passage to do a trysail drill while the boat is still tied to the dock. Practice dropping and lashing the main-

R

1979 Fastnet Race

The first time I set a storm trysail was during the 1979 Fastnet Race, the now infamous race in which 21 people died during a severe gale that rolled through the fleet midway through the race. Seventeen people who were participating in the race died as well as the four-man crew on a small trimaran. When all was said and done 19 boats were abandoned, five sank and only 85 of the 303 starters managed to finish. I was sailing on a Swan 57 called Battlecry, and we had just rounded Fastnet Rock off the Irish Coast when the storm picked up intensity. The night was as dark as any I can remember, and as the storm heightened and the seaway worsened, both the spirit of the crew and a couple of the boat's ring frames took a turn for the worse. Some frames had cracked, and the pressure of the waves coming over the boat was forcing the small gap to open up and let in water. Unless we reduced pressure the boat was going to sink, a rather unpleasant thing to contemplate in the North Atlantic in the middle of the night in the middle of a gale. At the time we were still racing, and with a deep-reefed mainsail and storm jib were heading back toward England. That was until a call came from the captain to reduce sail further and turn the boat for Cork on the south coast of Ireland. Reducing sail meant dousing the mainsail altogether and setting the storm trysail. What I learned that night was a critically important lesson and led me to form a deep-seated opinion about the use of storm sails.

The crew of Battlecry was experienced, I was the “nipper” on board with only a little over 10,000 offshore miles under my belt, and we had raced as a crew all summer, so we knew the boat well. Still, none of us had ever set a storm trysail. In fact, only one person on board even knew where it was stowed, and he was seasick. As it turned out, the sail, like the storm sails on so many boats, was buried under the bunks in the forepeak so that just getting to it proved to be a gruelling exercise in balance and perseverance. Once we had the sail on deck and the mainsail doused, it took a full hour before we were able to figure out how to get the trysail onto the mast, and another half hour to get it set. All this time massive waves were crashing over the deck with the area around the mast being especially vulnerable. We were lucky not to injure anyone or lose anyone overboard. Later in the week, after we had made it to safe harbor in Ireland, I wondered how sensible it was for us to have attempted to set the trysail after all. In fact, I came to the conclusion that it was probably the stupidest thing we could have done given the circumstances. Random polls taken since have confirmed my suspicions that almost all crews taking part in offshore races like the Fastnet have never done a trysail drill, and I conclude that most crews would be better served by just leaving the sail under the bunk rather than placing their lives at potential risk trying to set the sail for the first time during a storm.

R

sail, and then setting the trysail. The crew will be able to get a feel for the size of the sail and see how it attaches to the mast relative to the mainsail. They should all know where the sail is stowed before leaving the dock.

Other Factors to Consider When Setting Storm Sails

Many other factors come into play when it comes to storm sails. Different boats have different needs, a fact that was brought home to me aboard my own boat in a gale in the Gulf Stream. With water spouts developing on the edge of the Stream and gale-force winds threatening to rip the rig out, I dropped the mainsail and attempted to make do with just the storm jib. On this boat, however, the mast was far forward, and the boat could not respond without a second sail to balance the helm. Fortunately my crew and I had done a trysail drill, and we were able to set the sail without too much trouble.

Of course, some boats will sail just fine with only a storm jib set, especially boats with long keels and balanced sailplans. The old cruisers that had keels that ran the length of the underbody, although slow and cumbersome, were very seakindly. The long keels gave them directional stability that even an unbalanced sailplan, i.e., too much sail forward or aft, could not mess with. On the other hand, many fin-keel boats without much underwater shape will suffer without both an effective storm jib and trysail set at the same time, since there is not enough lateral stability under the boat to help it ride the waves. The result is that the sails end up dictating how the boat will lie relative to the seaway. Therefore, setting only a storm jib without the trysail to counterbalance the sailplan would make it very difficult to keep the boat on a steady course.

Sea state or the boat's location also need to be taken into consideration when deciding whether or not to bend on storm canvas. If, for example, a lee shore looms and the boat needs the trysail to balance the helm in an effort to claw to windward, then it's a reasonable trade to endanger the crew's lives to set the storm sails. The alternative, a grounding, makes the choice an easy and obvious one. On the other hand if there is plenty of sea room and the boat is managing okay, then leave the crew below where they will be safe since the worst that will happen is that you will end up a hundred miles off course.

In the situation aboard my boat in the Gulf Stream where we had ample sea room, the boat would not sail on autopilot with just a storm jib, so I deemed it a reasonable risk to set the trysail to balance the helm, and then keep the crew below where he would be safe rather than have him on deck hand steering. The fact that we had also practiced setting the sail played a role in my decision. Again, these decisions need to be made by each skipper on a case-by-case basis. The point is that all sailors need to look at all the factors when making decisions during severe weather. When the wind is up and the senses are heightened, it's important to consider all options, even the unconventional ones.

One final point to consider when deciding whether to set a storm trysail concerns the mast. Generally, modern masts require the support of a mainsail or trysail pushing against the trailing edge of the spar to add to the structural integrity of the mast, so setting a headsail alone could actually result in the loss of the entire

“The old cruisers that had keels that ran the length of the underbody, although slow and cumbersome, were very seakindly.”

An intense low pressure system approaching the Bay of Biscay in October 2002 forced many of the Around Alone yachts to seek shelter in Spain.



rig. The heavy masts found on most cruising boats, on the other hand, are fine without the mainsail, although you should be sure to check with the spar maker for his advice since you may need a sail set to support this kind of mast as well.

Storm Preparation

It's human nature sometimes to deny the obvious, especially when work is involved and that work is dangerous and means getting soaked. We are all guilty of it. The forecast is for a gale, yet the conditions are still manageable and we convince ourselves that it will not be as bad as forecast. My experience is that storms take people by surprise, and that is when they do their most damage. It's true that often the forecast is wrong and the wind does not blow like expected, but sometimes the forecast is right. Prudent seamanship means that all sailors should plan for the worst and be grateful when it does not happen. This includes preparing storm sails. It really is important to do a dry run at the dock so that all the crew know where the storm sails are stowed and how to use them. Races like the Newport to Bermuda Race now make it a race requirement before they will let you start. It's equally important for you to prepare for an approaching gale well in advance. Hanking the storm jib onto the inner forestay and preparing to drop the mainsail is more easily accomplished before the wind comes up than after it has started blowing. Know your boat. Know if it needs the trysail or if the boat can sail on a storm jib alone. Decide whether having your crew at the mast feeding slides onto a track is an acceptable risk (especially at night). Think about the sheeting positions of both sails and be sure that the blocks are secured to their pad eyes long before the leeward pad eyes are underwater. Storm sails are a very important part of your safety – know how to use them and be prepared to use them well in advance of increasing wind. Sometimes the only thing standing between you and disaster is preparation.

Chapter 10

SAIL INVENTORIES

A Look at What Sails You Need for Your Sailing Purposes

The first nine chapters of this book have focused almost exclusively on sail design, construction, and theory: what sails are, how they are made, what they're made of, why they look the way they do, and how advances in sailmaking technology will affect the sails of the future. Now it's almost time to use these wonderful products, to abuse them, to fix them, and to figure out which sails are best for you and your boat. In other words, we're coming to the fun part. Still, before we take to the water to learn how to trim and handle our new sails, let's first decide just what sails we need. Like just about everything else in sailing, a little forethought can save you a world of hurt or heartache somewhere further down the road.

For example, do you want to race, cruise, or a combination of both? Your answer to this question can have a profound effect on the sails that you ultimately choose. Furthermore, if racing, are you a part of a class that places specific restrictions on the number and types of sails that you can buy, or are your options dictated only by the size of your wallet? If you cruise, are you daysailing, weekend sailing, coastal cruising, going bluewater, or venturing around the world? Ultimately, the size, shape, and number of sails you choose to include in your inventory will depend on your sailing goals. Think long and hard about your objectives, and don't just go with your first impulse. Rather, in addition to planning for your immediate sailing needs, try to anticipate what your plans might be in the future. For example, you might be sold on weekend racing for now, but know in the back of your mind that a race to Bermuda is in the cards. With that in mind when buying a new mainsail you might decide to have your sailmaker add some light Dacron taffetas to the laminate to give the sail that extra level of durability it will need for an offshore passage. Similarly, after years of cruising, you might be toying with the idea of trying some Wednesday night racing to see how your boat does around the cans. As a result, when it comes time to get a new genoa, you might want to go with a slightly more sophisticated design with more stretch-resistant materials, or maybe even a molded sail to give that extra edge in terms of performance. It's this kind of planning that allows you to get the most from your sails. Before we look at specific categories of sailors, let's first look at some of the other sails we might need in our inventory as well as some of the newer sail-handling systems.

The Working Staysail

On all boats with a foretriangle large enough to accommodate an inner forestay, the working staysail is a very important part of any inventory (Figure 10.1 on next page). On most boats the inner forestay is about one third of the way back from and parallel to the headstay. As soon as a boat bears away onto a reach, the gap between the mainsail and headsail widens, and the effect they have on each other

“Like just about everything else in sailing, a little forethought can save you a world of hurt or heartache somewhere further down the road.”

Figure 10.1

On all boats with a foretriangle large enough to accommodate an inner forestay, the working staysail is a very important part of any inventory.

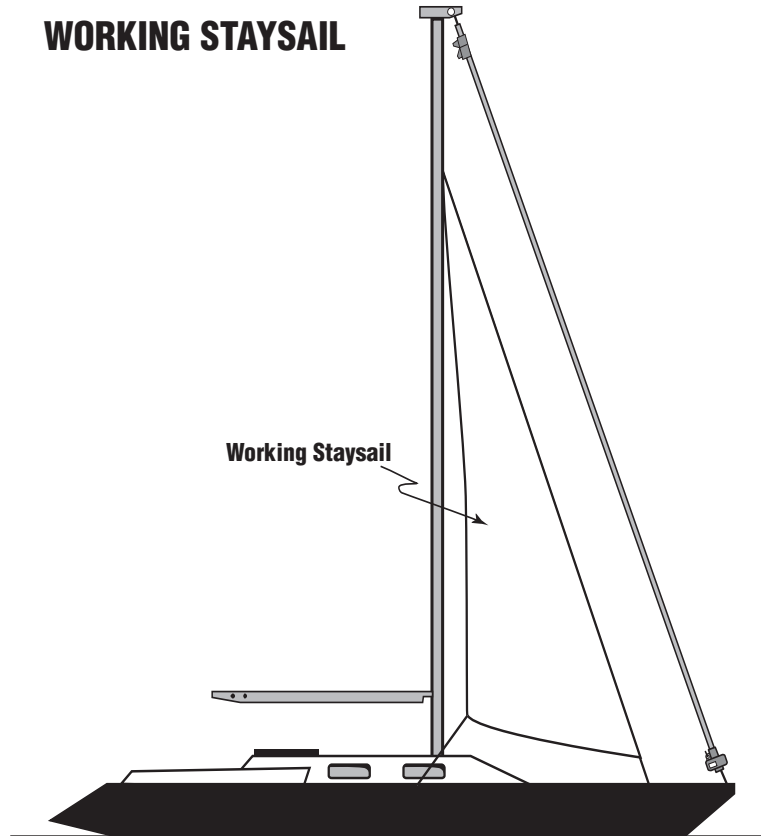

is reduced. While creating lift is no longer important, keeping wind circulating between sails is, and setting a staysail effectively fills the gap. A working staysail is a full-size, fairly rugged working sail that sets on the inner forestay and can be used on its own as a heavy-weather sail or with the headsail when reaching.

Many larger boats will have a removable inner forestay so that the stay can be pulled back to the mast when it is not needed. The stay is attached to the foredeck with an over-center lever that, when in place, allows a reasonable amount of tension to be placed on the stay. This is useful especially when short tacking with an over-lapping headsail. Other more serious passagemakers like to have a series of inner stays with roller-furling units on each of them. The first stay is just aft of the headstay with an inner forestay in its usual place and a babystay close to the mast. The advantage of this is that you can have different size headsails on each stay and unroll the one most appropriate for the conditions. While this is a nice convenience, there are some drawbacks. The weight of three furling units with rolled-up sails adds to the heeling and pitching moment of the boat, to say nothing of windage. The second problem is that it's very difficult to get sufficient headstay tension on all of the stays. As soon as you have one right, the one closest to it is not right. Hydraulic rams at the base of each stay go some way toward getting decent tension on the stay you are using, but it's a cumbersome process.

For smaller boats there are two inner forestay options that work very well. One is the self-tacking jib, or club-foot jib, and the other is the Hoyt Jib Boom. In fact,



both of these options can be found on many cutter designs. The self-tacking jib is a non-overlapping staysail set with a rigid boom along the foot. The sheeting systems vary a little from boat to boat, but the idea is to have a sliding track in front of the mast that allows the sail to move freely from one side to the other. When the boat tacks the sail slides across to the other side keeping the same sheet tension as you had before you tacked. A more modern configuration on the same theme is the Hoyt Jib Boom designed by innovator Gary Hoyt. This boom is essentially a club-foot jib, however, the boom is rigid and keeps the leech of the sail from riding up when the sheet is eased. The Hoyt Jib Boom works especially well sailing downwind when it can be set wing-and-wing with the headsail.

The Hoyt Jib Boom is an effective system for controlling the leech of the headsail when sailing downwind.

Mizzens

Mizzens are still popular on more traditional cruising yachts, and for passagemaking they are an ideal sail. They don't offer much when sailing upwind other than to balance the sailplan, but as soon as projected area comes into play when sailing off the wind, the mizzen finds its stride. Because traditionally most mizzens were small sails, especially those aboard yawls, they did not add much to the performance of the boat. But in recent years there has been a trend toward larger mizzens aboard big ketches like some of the offshore designs created by Steve Dashew. Small mizzens need only a single reef point, or none at all. Once the size of the sail increases you might consider a second set of reefs, but on the other hand most sailors just drop the sail at that point. It depends on the boat and the amount of weather-helm the sail back aft is creating. The fabric for the mizzen will match that of the mainsail, only it will be a lighter weight.

Mizzen masts on some boats are quite effective, while on other boats they just provide a good place to hang the radar.

Mizzen Staysails

Some cruisers will say that the best thing about a mizzen mast is that it gives them a place to fly a mizzen staysail (and hang their radar!). A mizzen staysail is a very useful



The mizzen staysail on this boat is providing a lot of extra power.

A Trusted Ally

I have come to rely on the working staysail like a trusted ally, one that has been with me on numerous passages and even around Cape Horn a few times. I cut my teeth offshore doing yacht deliveries to the Tropics. Some deliveries were done in the days before roller-furling was invented, so once the early furling systems came along I could truly appreciate that fact that they were a vast improvement over hanked-on headsails. Many of the boats I have sailed on have had a sail configuration that I have come to know and rely upon: a reefing headsail and hanked-on staysail. As you approach the Tropics night squalls become more frequent, and whenever we see one visually or on the radar, we immediately roll away the headsail and weather the squall on mainsail and staysail alone. Once the wind dies down we unroll the headsail and continue on our way. As a rule, I trust hanked-on staysails much more than I do a reefed headsail, and many is the time that I have been grateful to know that I have a sail up that can take just about anything a squall can throw at it.



sail that is set from the masthead of the mizzen mast and tacked to a point on the deck. Usually the tack point is free floating. Once the wind is aft of 70 degrees apparent, you can set the mizzen staysail with the tack on centerline. Then, as the wind comes further aft, you can rotate the sail around by moving the tack to the windward side. This allows the plane of the sail to be more efficient. Mizzen staysails are usually a light nylon for small boats or a light laminate for larger boats.

Daisy Staysail

There is one sail that I am particularly fond of, a sail that is often found on racing boats, but hardly ever carried by cruisers, a sail with three names and a number of purposes. To some it's known as a Daisy Staysail. To others it's a Tall Boy while others simply call it a Windseeker (Figure 10.2). Regardless of the name, it is a high-aspect, loose-luffed sail usually made from a light fabric. Cruising sailors pre-

fer the sail to be made from nylon, while racers will opt for a light film-on-film scrim. The sail is set free-flying on a roller-furling unit. A wire or Spectra or Vectran line up the luff allows the sail to be snugged up tight so that the luff does not sag when the wind comes up. The wire also allows the sail to be rolled away when it's not needed. In its staysail format, the sail sets under a spinnaker or light-air reacher and is used to break the slot between the headsail and mainsail just as the working staysail would. By creating two slots you add power and performance to the foretriangle, providing there is enough wind and the angle is right.

It's also good for getting a boat moving when the wind is very light. It's all about creating apparent wind. If the Windseeker is able to get your boat moving, this apparent wind will combine with the true wind to provide more energy. Then, by having the Windseeker set on a roller-furling unit, it's a simple matter of pulling the furling line to get rid of the Windseeker as soon as the boat is moving. Once it's going and you have created enough apparent wind you can unroll your headsail. Leave the Windseeker where it is until the wind has filled in sufficiently to sail on the headsail alone. Once this is the case, drop the Windseeker and stow it below.

Categories of Sailors

To help you to figure out where you fit in, let's begin by dividing sailing into a number of categories and then look at the fibers and fabric types that might be most appropriate for each category.

WINDSEEKER/DAISY STAYSAIL

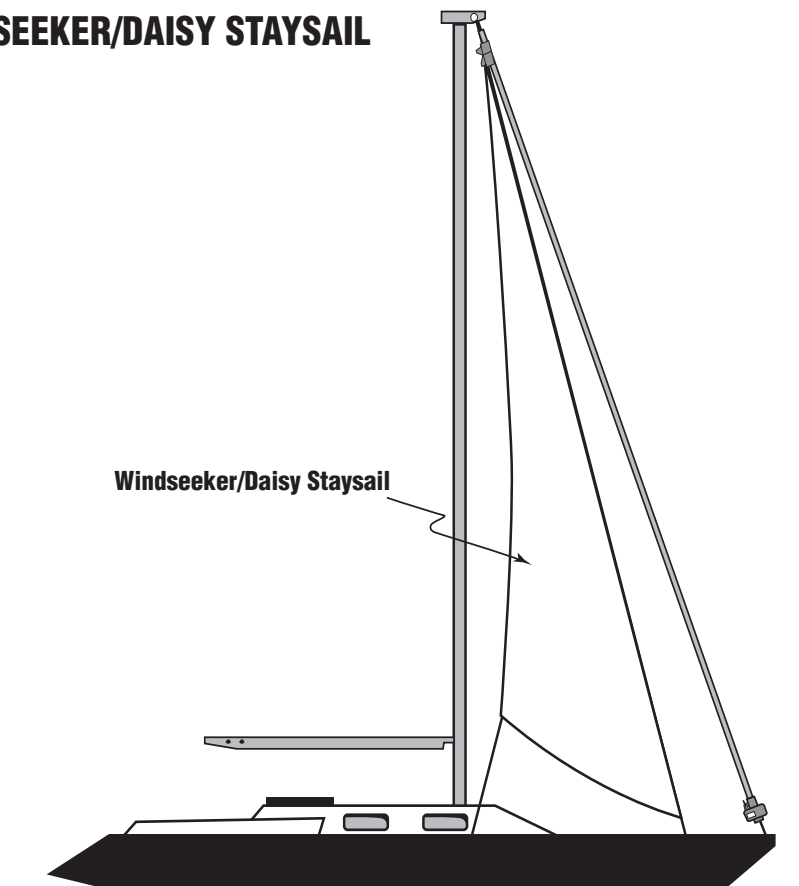

“Use the Windseeker to generate boat speed, which creates apparent wind.”

Figure 10.2

A high-aspect, loose-luffed sail usually made from a light fabric, the Windseeker is also known as a Daisy Staysail or Tall Boy.



There are few fleets more competitive than the Farr 40 fleet when it comes to grand prix racing.

Grand Prix Racing

Grand prix racing like that found in the America's Cup, the Transpac, the Farr 40 circuit, and other super-hot, one-design classes is the exclusive domain of those who seek performance above all else. For them durability, longevity, and cost are not a consideration. In Chapter 3 we looked at how an investment in fabric and engineering up front pays dividends down the road and concluded that if you measure the usefulness of a sail by how long it looks good and holds its shape, then paying for the best fabric for the job and giving serious consideration to the engineering is usually a wise investment. For the racing sailor this can be taken a step further. Since racing sailors care only about how long their sails will perform at a top level, they generally only consider what a sail is made of and measure its usefulness in three ways:

- Its shape.
- Its ability to hold its shape over a broad range of wind conditions.
- Its weight.

As stated earlier, you can always build a sail that has a good shape and holds its shape through a wide range of conditions. But if that sail weighs too much, the performance edge will be lost. An overabundance of material not only adds weight aloft when the sail is flying, but weight when stowed, which makes sail handling more difficult as well. With a number of sails on board it's critical to keep the weight/performance ratio in balance. Light sails set more easily, mini-

mize pitching and heeling when the boat is sailing to windward, and are generally easier to stow and drag around the boat. On the other hand, concentrating only on weight at the expense of shape is not a wise move.

Grand prix sailing can be further subdivided into inshore racing and offshore racing. The principal objectives are the same, but some of the finer details differ. With shape the primary consideration, the grand prix sailor will begin the process of choosing the fabric by looking at all available fibers and their durability in terms of a specific sailing environment. For example, sails designed for offshore may have more in the way of UV-resistant taffetas than those designed for inshore work, since they will be exposed to wind and water for days or even weeks at a stretch. The taffetas certainly add weight, but they give a sailor the degree of confidence in the durability of the fabric that he needs, knowing as he does that if the sail fails he will not be able to repair it. By the same token, even those offshore sailors who choose to leave the taffetas off will over-engineer the sail to handle the tougher conditions found at sea. This over-engineering will be in the form of larger corner reinforcement patches and slightly heavier denier fabric along the leech and foot of the sail.

Weekend Warrior

A step down from the lunatic spending fringe are those sailors who compete on weekends and in regional and national championships. They are also looking for performance, but not at any cost. Indeed, in many classes, exotic fibers are specifically banned in an effort to keep costs down. These classes will even restrict the number of sails that can be purchased so it won't become a battle of the bank accounts. Of course, when racing one-design, the dimension of the sails will be predetermined, and in many cases different members of a fleet will even buy their sails en masse from a single manufacturer in order to get a price break. Sailors who are competing under a rating rule will probably be on their own since their boat may be the only one of its kind in a fleet. But still they are seeking the same basic thing: shape retention through a wide wind range, while trading off variables like light weight and longevity. In many respects weekend warriors are like grand prix offshore sailors who will accept taffetas and higher yarn count in return for a slightly heavier sail, but one that lasts longer. These racers can expect their sails to last two to three seasons, possibly four with some recutting.

Where allowed, weekend warriors will turn to film-on-film construction for their light sails if weight is important to get the sail to set properly. Otherwise, they will look for something more durable for the heavier sails like two woven fabrics sandwiching a film. On bigger boats the fabric may be a woven/film/scrim/film/woven. The fiber of choice is still Kevlar or high modulus Twaron.

Club Racers

Most racing sailors fall into this category. Club racers are those sailors who like to mix it up on weekends and Wednesday evenings, but rarely venture out of state to race. They are looking for performance, but in the long run durability and cost

are just as important, if not more so. These sailors still like to have the performance edge that a laminated sail gives them, but they are not willing to have sails built from delicate yarns like Twaron and Kevlar. Instead, Pentex and in some cases polyester are good choices, either woven or in the form of scrim laminated to a film. Diagonal yarns can be added for off-threadline stability and to make the sails more durable.

Club racers also like to use their boats for cruising, in which case adding light taffetas to the fabric not only extends the range of sails (who likes to change sails when they are cruising?), but also adds a measure of durability. Club racers often have a separate 130-percent Dacron headsail that they use for cruising.

Performance Cruisers

Like that of grand prix sailors, this category can be divided into two camps: those who sail coastal and those who head for blue water. Again, because of the conditions found offshore, the sails will have to be more durable and rely more heavily on woven laminates and taffetas where applicable. Cruisers who choose to remain close to land might consider the performance advantage of an inserted scrim, but nothing quite beats the strength and durability of a heavy, woven fabric for offshore passagemaking. Depending on the size of the boat, performance cruisers might choose polyester or Pentex at the lower end of the range, and Spectra or Vectran for larger boats where the added strength and stretch resistance of a high-performance fiber is needed. The lay-up of these fabrics will depend on the size of the boat, and you will likely see woven/film/scrim/film/woven type construction or occasionally woven/scrim/woven.

These yachts approaching the windward mark are a good example of weekend warriors.



Traditional Sailors

For this type of sailor, high-performance Dacron is one possibility, though laminated fabrics are also attractive since they've become reliable, durable, and more affordable. Certainly for small-boat owners Dacron is still the fabric of choice, and for club racers it can definitely be a competitive fabric, although the bigger the boat and the more competitive the arena, the more need there is for a laminated sail from a higher modulus fiber.

Sail Inventories

Beyond the complex issue of fiber and fabric choice, you also have to decide what sails you need for the sailing you plan to do. Again, for racing sailors many of these choices are dictated by class and association rules, or by the size of your pocketbook. But for cruisers the decision remains personal and should be based on what you want to do with your boat.

A Basic Sail Inventory

For the bulk of sailors whose pleasure is derived from weekend and Wednesday night racing with an occasional cruise, the sail inventory could be made up from the following sails:

- Mainsail with two rows of reefs – each reef reducing sail area by 15 to 20 percent.
- All-purpose racing No. 1 genoa. 150-percent LP. *
- Blade/heavy-weather jib. 98-percent LP.
- 130-percent roller-reefing jib.
- All-purpose spinnaker (either symmetrical or asymmetrical).
- Storm sails.

Additional Sails

To be more competitive on the racecourse, or if the cruising or racing conditions call for it, add the following sails:

- Light-air racing No. 1 genoa. 150 percent LP.
- 95-percent roller-reefing jib.
- Working staysail.
- Daisy staysail/Windseeker.

Offshore Cruisers Inventory

With no plans to race, the offshore cruiser might have a sail inventory that looks like this:

- Mainsail with two rows of reefs – each reef reducing the sail area by 20 to 25 percent.
- 135-percent roller-reefing headsail.
- 95-percent roller-reefing headsail.
- Working staysail/heavy-weather jib.
- All-purpose spinnaker (asymmetrical).
- Loose-luffed genniker.
- Daisy staysail/Windseeker.
- Storm sails.

*See page 264 in Appendix for a definition of LP.

“ . . . nothing . . . beats the strength and durability of a heavy, woven fabric for offshore passagemaking.”

“It’s a question of seamanship when it comes to having a reasonable overlap between sails, and having a sufficient backup should one sail fail.”

Determining the Number of Reefs in the Mainsail

The number and size of mainsail reefs are dictated by two things: the kind of sailing you will be doing, and the type of boat you are sailing. Some cruising boats have a high righting moment and do not require deep reefs, whereas other boats are tender and need a quick and definitive reduction in sail area. The following is a basic guideline:

- **Daysailors** – no reefs.
- **Weekend cruisers** – under 35 feet – one reef that reduces sail area by 25 to 30 percent.
- **Weekend cruisers** – over 35 feet – two reefs each reducing area by 15 to 20 percent.
- **Coastal sailors** – two reefs each reducing area by 15 to 20 percent.
- **Bluewater sailors** – two reefs each reducing area by 20 to 25 percent.
- **Grand prix sailors** – two mainsails – one inshore main with no reefs, one offshore main with two reefs, each reducing area by 15 to 25 percent.

Final Thoughts

Sail inventories can be as complex or as simple as you want them to be, and often it’s a matter of personal preference. My own preference is to keep the sail inventory as simple as possible while still being able to cover the entire wind range adequately. I would rather invest in a higher-quality fabric that will allow a single sail to have a broader wind range, than choose something basic and find out later that I need two sails to cover the same range.

It’s a question of seamanship when it comes to having a reasonable overlap between sails, and having a sufficient backup should one sail fail. It’s not a good idea to set off across an ocean with a single-reefing headsail because your sailmaker told you it would be okay. You need a backup, preferably one that is smaller and stronger than your working sail. Never venture too far from shore without storm sails, and think about light-air sails that can keep you moving should your engine fail, or if you simply want peace and quiet. Study your options, consider your budget, think about your sailing plans, and talk to your sailmaker before making any decisions. It’s not only the number of sails and their cost that you need to consider, but also where you will keep the sails when they are not in use. Once you have taken a sail inventory, it’s time to learn how to trim the sails to get the maximum performance from each of them. That is where the real fun begins.

Chapter 11

THE FINE ART OF SAIL TRIM

How to Get the Most From Your Sails

Finally the time has come to cast the lines off and set sail. You point the bow of your boat away from land and feel it heel to a new breeze. Dark patches on the water signal that a new wind is approaching, and it blows away the stress and troubles that come from living in a fast-paced world. Before long the traffic and jams disappear over the horizon and you are one with your boat. You sheet in the sails and feel a surge of power as the boat responds. Knowing how to trim sails is a wonderful feeling, and knowing how to get that extra tenth of a knot from the boat is most satisfying. This chapter will focus on sail trim, both for cruising sailors who want their sails to perform well while they sit back, relax, and read a book, and for racing sailors whose quest is for a trophy cabinet full of silver.

Ultimately, sail trim is all about keeping a boat sailing fast and balanced, i.e., trimmed so that you don't have to use a lot of helm to keep going in a straight line. Many people forget how important the latter is to the overall performance of a boat, but in fact balance has a direct bearing on speed. Of course, if the wind and wave conditions remained constant, sail trim would be very easy. You would be able to figure out exactly what sail combination works for a particular set of circumstances, what chord depth provides the most power, and set your sails accordingly. Unfortunately it's not that easy, since conditions are forever changing, not just day to day, but even minute to minute. By the same token, it's this constant changing of wind, waves, and balance that makes sailing so interesting. At the most basic level, the key to getting the most out of your boat lies in the way you trim your sails.

Some sailors view sail trim as a scientific exercise, and by many measures it is. The relation of wind, waves, and foils is certainly an interesting study in physics. Other sailors, however, view the process as art, since no matter how scientifically inclined you may be, if you do not have an innate sense of the wind and how it relates to a sailboat, you are never going to be a trophy-winning sailor. Some people, for example, are just born with a gift and feel the wind through the seat of their pants. Even if they can't get their heads around the scientific theory, they are still able to sail circles around the competition. For the rest of us it can be a learned process.

By the end of this chapter we will have you trimming sails like a pro, tackling the problem of sailing to windward in the first half of the chapter, and easing sheets and heading downwind in the second half. First, though, we need to do some homework, reviewing the deck hardware that is used for the purpose of sail trim and what happens when we use it to make an adjustment. Furthermore, since the way you gauge what happens when you make an adjustment is by watching the telltales, we will take a quick look at these important and extremely simple

“Ultimately, sail trim is all about keeping a boat sailing fast and balanced, i.e., trimmed so that you don't have to use a lot of helm to keep going in a straight line.”



The telltales on the leech of this Farr 40 are all streaming perfectly meaning that the sail is trimmed properly.

Three good examples of telltales on the luffs of headsails. The windows help.

pieces of equipment. There's a reason they're called telltales. They tell the tale of how the wind is blowing across your sails.

About Telltales

It's not absolutely critical for you to have telltales on your sails. Indeed some cruising sailors scorn the idea, saying that they are gimmicks for racing sailors only. But there is no denying that they make sail trim a heck of a lot easier when sailing to windward, and if you are just starting out it's a good idea to have them installed.

At their most basic, telltales are simply short pieces of light fiber that are attached along the luff of a headsail and along the leech of the mainsail to indicate how the wind is flowing in these vital areas of the two sails. I say "fiber" because there is an ongoing debate among sailors as to what works best. Some sailors prefer strands of wool, even though it has a tendency to catch on rough spots like seams. Other sailors like thin strips of nylon spinnaker material. But these are not perfect either since they tend to stick to the sail when they get

wet. I was once told by a well-known Olympic sailor that Angora wool is the best for the telltales on the leech of the mainsail. The mass-to-weight ratio of Angora wool means that it flies easily in even the lightest winds.

On genoas and jibs the telltales should be installed down the length of the luff about 5 to 8 percent of the way aft from the front of the sail. Depending on the size of the sail you should have between three and six sets of telltales on either side of the sail and at staggered heights so you can easily determine which telltale is lifting without having to rely on their color. On mainsails they should be



attached to the leech of the sail at each batten. You can also install them down the luff in the same way you did on your headsail, but they will be less effective there because of the way air flows around a mainsail and the disturbance caused by the mast.

Installing Telltales

It is very easy to add telltales to your sails. Follow the procedure below for installing both wool and light nylon telltales.

Installing your own wool telltales:

- Thread a needle with wool and poke it through the sail.
- Pull the wool through the hole until roughly six or seven inches remains.
- Cut the wool leaving a further six or seven inches on the other side.
- Tie two overhand knots on either side of the sail right up against the fabric. This will stop the telltale from pulling through.
- If you want to stagger the heights then install a separate piece of yarn for each side, leaving a six- to seven-inch length on one side for each yarn and a half-inch length on the other side.

Installing light nylon telltales:

- Use a hot knife to burn strips of nylon a quarter of an inch wide.
- Attach them to either side of the sail with small pieces of sticky-back Dacron each about the size of a quarter.
- In addition to the telltales on the sails, you can also tie short pieces of wool to the shrouds and watch how they fly relative to the wind. By being away from the flow of wind around the sail you get a better indication of any fluctuations in the apparent wind direction. Of course, there are also plenty of more modern wind indicators like digital wind indicators or a Windex at your masthead, but for picking up the slightest shift in the breeze, telltales are still the best.

Mainsail Controls for Performance

For most sailboats the mainsail is the power plant, the figurative engine that makes the boat go. Granted it works with the headsail to provide overall power, but it is named the “main” sail for good reason. Fortunately, the sail has many controls that you can use to manipulate its shape as the wind and waves fluctuate. When trimming the main for sailing to windward, you will be trying to control two important aspects: the shape of the sail, and the angle of the sail relative to the wind. Some of the controls affect only one or the other, while other controls affect both. Let’s start by looking at the most important item – the mainsheet.

The Mainsheet

The mainsheet is one of those controls that serves a dual purpose in that it is used both to pull the mainsail in toward the

An example of a simple mainsail handling system.





All the telltales on the leech of this mainsail are flying indicating that the sail is trimmed perfectly.

boat's centerline, i.e., to control its angle to the wind, as well as to control the amount of tension on the leech of the sail. When a boat is on a reach or run and the boom is no longer directly above the mainsheet, leech tension is controlled by the boom vang or main traveler. When the boom is on or near centerline when sailing to windward, the sheet is the most effective means of controlling this aspect of sail shape. Note that by regulating leech tension, the mainsheet also controls the amount of twist, which is very important to the overall performance of a sail. For example, as soon as the sheet is wound on too much, the leech becomes tight and cups to windward. This not only adds depth to the sail, but can also disrupt the flow of air along both the leeward and windward sides. Easing off the mainsheet will allow the leech to open up and increase twist in the upper portion of the sail. On small boats, especially singlehanded dinghies without backstays like the Laser or Finn, the mainsheet will also affect mast bend. It does this in two ways: first, by pulling back on the top of the mast via the leech; and second, by pushing the middle of the mast forward by loading up the boom. On larger boats, mast bend is adjusted primarily with the backstay and running backstays. But it's still good to keep in mind the effect that mainsheet tension can have on the spar.

The best way to gauge the correct amount of tension is to sight up the sail by standing below the clew and looking up. As you wind the mainsheet in so that the boom is over the center of the boat, you will see

the line of the leech go from curved to straight. At first all the telltales will be streaming out behind the sail. This indicates that the wind is flowing off the back end of the sail without interruption, although it's unlikely that the back of the main has started to provide power or lift. Wind the sail tighter and watch what happens. As the leech becomes straighter, the telltales will continue to stream until you overtrim the sail, at which point the top telltale will start to dip behind the mainsail closely followed by the rest of them. When this happens you should ease the sheet until all the telltales start streaming evenly again, indicating a smooth and steady air flow. What's happening here is that at first the wind is just blowing across the sail, since the sail does not yet have an aerodynamic shape and there is no power being generated. As you begin to trim the sail, however, it starts to assume a more aerodynamic shape with the back end coming into play. Specifically, as the back of the main starts to go from curved to straight it begins to provide power. Not only that, the center of effort in the whole sailplan

starts to move aft creating weather helm, which forces the water to attach to the underwater appendages and in doing so they start to generate lift. If, however, you wind the sail on too tight, the air toward the leech will begin to stall because it can't exit the sail easily, and with the flow over the sail disrupted it begins to lose drive. You will still have weather helm and the water will still be attached to the underwater appendages, but because the boat speed has slowed they will not provide as much lift, because the faster you sail the more lift they will generate. Eventually, if you do not ease the sheet and start to get the wind flowing across the mainsail again without disruption, you will slow down to the point where you will start to make a lot of leeway. At this point you are no longer going where you want to go. It's a delicate balance, and one of the reasons why the mainsail trimmer needs to work so closely with the helmsman.

In smooth water with between 5 and 10 knots of true wind, having the top batten parallel to the boom is another indicator of a mainsail that is correctly trimmed. As the wind increases the top of the sail will twist off naturally, and that's a good thing. In winds less than 5 knots you will want to ease the mainsheet and vang, if you are using one, to allow the top to twist open a little, cocking the batten slightly to leeward. This allows the wind to exit the sail smoothly and will help keep your boat speed up. When the wind is light it is really susceptible to stalling and as soon as it does you lose any power and lift that might have been generated. In stronger winds it's easy to get the wind to start flowing again because there is that much more wind available, but in light airs be careful, erring on the side of an open leech where the wind can exit the sail easily.

Mainsail Traveler

While the mainsheet controls both the amount of tension on the sail and the overall plane of the sail relative to the wind, the main traveler actually offers a more effective way of adjusting the angle of attack, or "relative plane" of the sail when the boom is close to the centerline, since you can do so without changing leech tension, as is the case when you trim or ease the main. At its most basic, the mainsail traveler is an athwartships track that sits under the boom and is mounted either on the deck or coach roof depending on the design of the boat. The mainsheet is attached to an adjustable car on the track, which is controlled with a set of lines and blocks, the amount of purchase dictated by the size of the boat. The car can be pulled to windward of the centerline of the boat, or it can be lowered down the track. Pulling it to windward narrows the angle of attack of the mainsail, while lowering it widens the angle of attack. A narrow angle of attack allows you to point higher, while the opposite is true for a wide angle. If the mainsail is in a header you can have the boom at or above centerline without the sail stalling, and in order to do this you have to use the traveler.

In heavy air the traveler can be especially helpful since the car can be eased down the track whenever the boat is overpowered, thus alleviating any excessive weather helm created by the stronger winds and the heel of

A block and tackle system with cleats allow the main traveler on this boat to be easily adjusted.

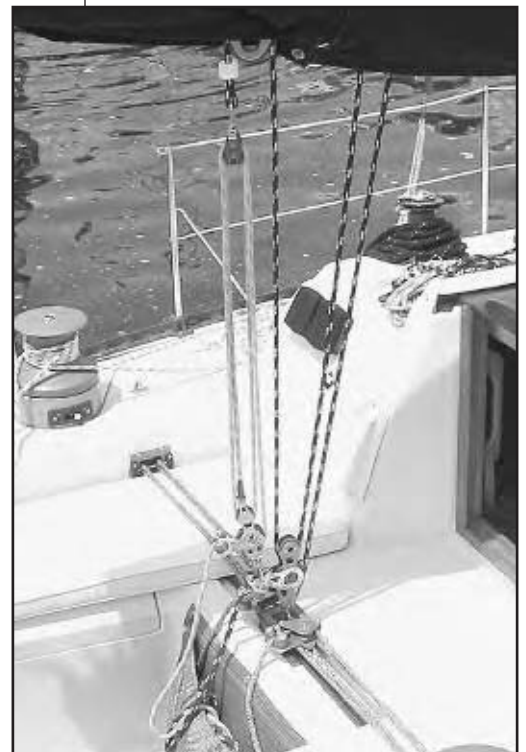

the boat. Again, by adjusting the mainsail with the traveler rather than the mainsheet, you can keep the leech of the sail working while fine tuning the amount of weather helm. In fact, on a racing boat, a good mainsail trimmer will be in constant communication with the helmsman to make sure there is just the right amount of weather helm, something that can be easily controlled by the traveler. If there is too much the helmsman will have to turn the wheel excessively to compensate, and the water flow will separate from the rudder. Too little or neutral helm will make it hard for the helmsman to get a “feel” for the boat, and for water to attach to the rudder and provide lift. Cruising sailors, of course, are not as concerned about the fine line between lift and power. They certainly do not want to spend their days tending the mainsail controls in a never-ending effort to get in a “groove” like their racing counterparts. Still, it makes sense to find a happy balance, bearing in mind the points mentioned above so that you can sail that much more efficiently and easily. Then, once you find that balance you can cleat the sheets and go back to what you were doing.

Vang

In some circles, the vang is known as a “kicking-strap.” It controls the angle of the boom relative to the mast, and by extension, the amount of twist in the mainsail. Most of the time when you are sailing to windward, the twist and boom angle is dictated by the mainsheet. It is only when the main traveler is eased to the end of the track, and the sail needs to be eased out further, that the boom vang comes into play. Without it, as soon as you ease the mainsheet the top of the sail will open up, and you will lose what power you had. Having the vang there to control the angle of the boom will keep the leech of the sail working once the boom is beyond the lifelines.

These days many boom vangs are hydraulically operated and serve to hold the boom up as well as down. This is important because when you are reefing you need something to support the boom when the mainsail halyard is eased. If your vang is a block-and-tackle purchase you will need to have a topping lift attached to the end of your boom to stop it from dropping down when you reef. The disadvantage of a topping lift is that it can chafe the sail and sometimes even foul the leech, although some one-design classes require that their members carry this piece of equipment if they are to compete legally. Some boats have a fixed

Two examples of boom vangs. The one on the left is a hydraulic vang, and the one on the right has a rigid tube to serve as a topping lift while the block and tackle is used to tension the vang.



mechanical vang that is adjusted by a wheel on a threaded rod. The adjustment is a bit clumsy, but the advantages of having a fixed vang to hold the boom up when reefing are often worth the inconvenience. Some boat owners do not want to have hydraulics on their boat, and in that case this kind of mechanical vang is a good alternative. With smaller boats, on the other hand, a block and tackle will usually suffice. One last point: the boom vang should be quick and easy to release if you have a long boom, since on a close reach the end of the boom may drag in the water creating a point load where the vang attaches to the boom. In fact, this is the situation in which many booms fail. On centerboard boats it is also important that you be able to release the vang quickly in order to dump air from the top of the sail, since in high winds this can mean the difference between staying upright or capsizing.

The above three devices control the plane of the sail relative to the wind, and in the case of the vang, help when reefing. The mainsheet does have some effect on the shape of the sail, but there are other controls that can be used to manipulate and fine-tune the shape of the sail. The most important are the fixed backstay and the running backstays.

Backstay

In Chapter 6 we discussed how a sail designer adds curve to the luff of the mainsail to match the curve of the mast. He anticipates the amount of bend and designs the sail accordingly. If you are able to bend the mast more than the anticipated amount, the luff of the sail is pulled forward and the fabric stretches to accommodate the bend. This pulls shape from the rest of the sail and effectively flattens the chord of the mainsail. Conversely, if the mast has less bend than anticipated, the excess luff curve is thrust into the body of the sail adding depth to the sail. The amount of bend in the mast is controlled by the amount of tension you apply to the backstay. As stated earlier, on small boats like dinghies, the mast can be bent simply by tightening the mainsheet. But on keelboats you should have an adjustable backstay since the spar sections are much beefier and beyond the capability of the mainsheet to control.

In the past you may have noticed short, vertical marks along the luffs of some racing mainsails and wondered what they were. In fact, these are used to estimate the amount of bend in the mast. By sighting from the gooseneck and looking up the sail, you will be able to see how much the mast has bent by noting where the marks lie relative to an imaginary line running between the tack and head of the sail. If you know the distance between marks, you will know how much bend there is in the mast and you can use this knowledge as a reference for trimming the main at some other time.

Today, most large boats have a hydraulic ram at the base of the backstay that can be used to shorten its length. Some cruising boats have a threaded mechanical backstay adjuster similar to a mechanical boom vang, while small and medium-sized racing boats rely on a block-and-tackle purchase. Whatever the case, shortening the backstay pulls the top of the mast aft, forcing it to bend. As the mast bends, the luff of the sail is pulled forward and shape is removed from the sail.



This mechanical vang works well for tensioning the backstay, but it's slow and cumbersome and best left to cruisers.



The hand-drawn gauge attached to this hydraulic backstay adjuster gives the sail trimmer quick and easy reference points.

Swept back spreaders on Brad Van Liew's Open 60 Tommy Hilfiger Freedom America add lots of stability to the mast, but restrict the amount it can be bent.



Running Backstays

Running backstays come in pairs, one to a side, and are not permanently fixed. Instead they can be eased off or removed on the leeward side when not in use. In most cases, running backstays will run from the aft weather side of the boat to a point on the mast usually two-thirds of the way up the spar. If the mast is sophisticated there might be two, or even three sets of running backstays on each side that can be independently adjusted. In this case the lower running backstays are called checkstays.

If your boat is equipped with running backstays and checkstays, or “runners” as they are most commonly known, you can use them to arrest the bend of the mast instead of just having it bend of its own free will. Specifically, as you tighten the backstay the mast will only bend until the runner comes tight, at which point the spar will no longer bend. The runners can also be used to straighten the mast if doing so will help you achieve a desirable sail shape. Furthermore, in concert

with the backstay they can be important in controlling the shape of a headsail since tension aft will apply tension to the forestay. This interplay between the backstay, runners, and forestay is important to overall sail trim. Note that by manipulating the backstay and runners you are not only controlling the amount of camber in the mainsail, you are also affecting its location, since as the mast bends and pulls shape from the sail, it pulls it from the front of the sail, with the result that the location of the maximum amount of camber moves further aft. In mainsails you want to keep the point of maximum draft at roughly the midpoint of the sail, something you should always keep in mind when adjusting the other aspects of mainsail shape.

In recent years there has been a trend away from the running backstays that were so prevalent in the past. Before fabrics became really stable you needed to be able to manipulate sail shape in quite large measures, and bending masts was a good way of doing this. Having a mast that relied heavily on running backstays to keep it upright, however, was not something many sailors were keen on, so with the advent of newer sailmaking materials the trend has been toward fixed swept-back spreaders to support the mast without all that extra rigging. One drawback to these newer setups is that once the rigging is tight you are not able to bend the mast so much. Fortunately, with precise sail engineering, this is not the issue it used to be.

Halyard Tension and Cunningham

Tensioning the halyard or cunningham stretches the fabric along the front of the sail. In doing so fabric from further aft in the sail moves forward to take the place of the stretched fabric, which effectively pulls the point of deepest camber forward as well. Note that as mentioned in a previous chapter, adjusting either the halyard or cunningham accomplishes the same thing. Some boats do not have a cunningham so the only way to adjust the amount of tension on the luff of the sail is by using a halyard. But it is easier to adjust the tension with a cunningham because when you use the halyard it pulls simultaneously on both the luff and the leech, making it that much more difficult to adjust, especially on larger boats. In the latter case you may even have to ease the mainsheet, turning an otherwise simple procedure into a far more complicated one. It's much better to just pull down on the cunningham, which has the added advantage of a two-to-one purchase.

Some racing classes also require that bands be painted on the mast, with the rule requiring that the luff of the mainsail fit between the bands. If this is the case, the sailmaker will build the sail to fit precisely between the bands in light winds. As the wind increases and the sail stretches, you will have to use the cunningham to move the draft since taking up on the halyard would pull the sail above the top band, in violation of the rule.

Under sail you can use the cunningham or halyard tension to move the point of maximum camber forward when the mast bend forces it aft. You can also use these devices to keep the draft in the right place when it is forced aft by an increase in the wind. You will notice that when the wind builds the front of the sail starts to develop wrinkles perpendicular to the luff of the sail. This is a sure sign that the mainsail fabric has stretched (and possibly the halyard as well) and that the draft in the sail has migrated away from the mast. Therefore, be sure to use the cunningham to drag it forward. Be aware that when you bear away onto a reach, the amount of tension on the sails and rigging is sharply reduced, and it's likely that the luff tension you established with the halyard and cunningham is now too much and will pull the camber in the sail too far forward. In this case you need to loosen things up again to let the draft return to its proper location back at the mid-point of the sail.

Outhaul

The outhaul is one of the most effective ways to control the depth of the sail and is usually adjusted by a block and tackle system or, in some cases, a small hydraulic ram mounted inside the boom. While bending the mast and manipulating the cunningham are important, nothing works better to add or reduce camber in the lower part of the sail than adjusting the position of the outhaul. Note, however, that because there is often a lot of tension on the leech from the mainsail pulling directly against the outhaul car, you might need to ease the mainsheet on a larger boat before you can move the outhaul. To add depth to the sail, ease the outhaul. To flatten the sail, tighten the outhaul. Because modern sails are designed with precise seam shaping, low-stretch fabrics and so on, changing the position of the outhaul does not have the dramatic effect on overall depth as it used to with older

“Under sail you can use the cunningham or halyard tension to move the point of maximum camber forward when the mast bend forces it aft.”

sails. But it is still a quick and fairly dramatic way to power up and depower sails, and for racing sailors at mark roundings, it remains an effective sail trim device. By powering up I mean adding depth to a sail, depowering being the opposite.

Flattening Reef

The last control device you have is the flattening reef, which is an effective way to remove shape from cross-cut sails. As we discussed in Chapter 7 you can negate the shape induced by the tack seam on cross-cut sails by taking up on the flattening reef, thereby flattening the overall profile of the sail. Because of the way shape is added to radial sails, the flattening reef will not work. In fact, it is unnecessary since radial sails stretch much less than cross-cut sails.

Headsail Controls for Performance

Although it might not be the “main” sail, the shape of the headsail is also critical to the performance of the boat, and keeping the camber in the right place and the depth of the sail consistent with the amount of wind is paramount. Unfortunately, the headsail is in some ways harder to control than the mainsail because it is attached to a headstay that is hard to adjust, and the only real controls at your command are the sheeting angle, the amount of backstay tension and halyard tension. Compare that to the mainsail which has a mast that can be bent, a foot that can be tensioned along the boom and a number of other devices to manipulate the position of maximum camber. Still, headsail shape is not completely a matter of chance. It just takes a little extra know-how. Once again you have a number of means at your disposal for making sure that your jib or genoa has the right shape, including the aforementioned backstay.

Backstay

As we discussed under mainsail controls, tightening the backstay pulls the top of the mast aft. So if you are able to keep the mast either straight or at a fixed amount of bend, continuing to tighten the backstay will have a direct effect on the headstay. Specifically, as the top of the mast comes aft it will apply tension to the forestay, reducing the amount of sag and bringing it forward and inboard. If you ease the backstay allowing the top of the mast to move forward, it will reduce the amount of tension on the forestay, increasing sag and allowing it to curve to leeward. While it's impossible to eliminate sag completely from a freestanding wire, applying tension can reduce it appreciably. Among other things, more sag means that the luff of the headsail moves closer to the leech adding shape to the sail (Figure 11.1). Conversely, tightening the headstay reduces sag and by moving the headstay away from the leech flattens the overall shape of the sail. This is a reasonably effective way of adding or reducing camber, and therefore drive from the sail. As with the mainsail, however, it's important to remember that changing the amount of depth in the sail also affects the location of the camber, since as you apply tension to the headstay, it pulls fabric from the front of the sail and the location of maximum draft drifts aft. In order to keep it at the desired 33 to 38 percent aft, you need to do the same as you did with the mainsail: either apply tension to the halyard or take up on the cunningham.

Figure 11.1

More sag means that the luff of the headsail moves closer to the leech, adding shape to the sail. Conversely, tightening the headstay reduces sag and by moving the headstay away from the leech flattens the overall shape of the sail.

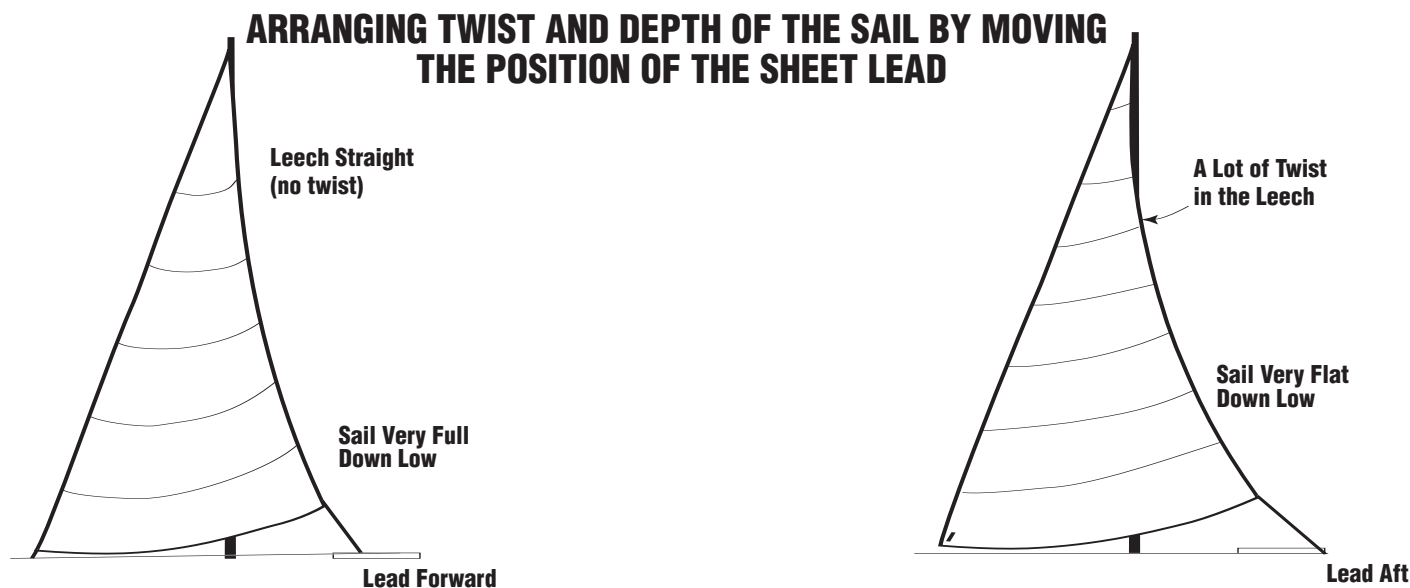

Halyard Tension and Cunningham

Just as we learned when trimming the mainsail, adjusting either halyard tension or the cunningham can move the point of maximum draft in the sail. Tighten it to pull the shape forward; ease it to let the shape drift aft.

Sheet Position

This is obviously a critical control device, not only for sheeting the sail in tight to control the sail's angle to the wind, but also to adjust the tension along the foot and up the leech of the sail. In most circumstances you want equal tension on both the leech and foot, and if the headsail has been properly designed this will result in the correct amount of twist in the leech so that the sail will set perfectly. You should also think of sheet tension as a way to flatten the shape of the sail. The harder you crank in on the sail, the flatter it will be. Conversely easing the sail out a few inches will allow the fabric to assume its normal, relaxed state, and the sail will have more shape.

At times you may want to change the power of the sail or increase the twist to accommodate a bend in the wind. You can do so by moving the position of the sheet lead. Moving the lead forward adds depth to the bottom of the sail. At the same time, it pulls down on the leech, reducing the amount of twist (Figure 11.2). This will add power to the sail, although you need to be careful not to close the leech too much and stall the air aloft, i.e., curl the leech inward so that the air separates from the back end of the sail. Conversely, moving the lead aft will flatten the foot and open the leech. This is an effective way to depower the sail and to reduce heel, although you need to be careful you do not open the top too much and lose lift. Like most things on a boat it's a balancing act between power, heel, and boat speed.

Figure 11.2

Moving the lead forward adds depth to the bottom of the sail. At the same time it pulls down on the leech, reducing the amount of twist. Moving the lead aft has the opposite effect.

Sheet Lead Position

- Lead forward – reduces twist – powers up the sail by adding depth.
- Lead aft – increases twist – depowers the sail by reducing depth.

If you have telltales installed along the luff of the sail, they need to break evenly, i.e., when the sail starts to luff the telltales on the windward side should all begin fluttering at the same time indicating that your sail is trimmed properly. To check this, sheet the sail on tight and slowly turn the bow of the boat into the wind. If the telltales start to dance at the same time, your lead position is correct. If the top telltale breaks before the rest, you need to move the lead forward; if the lower telltale is the first to go, move the lead aft. By moving the lead forward you are tightening up on the leech of the sail and effectively causing the top of the sail to be trimmed earlier. Moving the lead aft will effectively trim the lower part of the sail sooner so that it will be in sync with the rest of the sail.

Telltales and Sheet Lead Position

- Top telltale breaks first – move lead forward.
- Bottom telltale breaks first – move lead aft.

“ . . . it is important to view the overall sailplan as a single entity and watch what happens when you make adjustments.”

If you are having trouble getting all the telltales to respond at the same time, you might have a problem either with the overall shape of the sail or the luff curve. In either case, a sailmaker will be able to tell you, although you can also see for yourself by going to the bow, standing in front of the headstay and sighting up the sail. Look up the leeward side and check if the sail is smooth or bumpy. If it's smooth, you might have a problem with the shape of the sail; if it's bumpy, the problem is likely with the luff curve. If the luff curve is not even, perhaps the sail was not put together carefully enough. If it's smooth then the problem may be with the shaping of the panels near the luff of the sail; either they were not designed properly, or perhaps the fabric has distorted.

Windward Sail Trim

As we move on to the specifics of sail trim, you need to bear in mind that even small adjustments to a sail may have unexpected consequences. Therefore, it is important to view the overall sailplan as a single entity and watch what happens when you make adjustments. For example, as stated earlier, when you wind the backstay on, you not only bend the mast, you move the top of the mast aft a few degrees. This movement will in turn have an effect on the clew height of the headsail (Figure 11.3), and if there has been a significant amount of movement, you will have to move the lead position. Also think about what happens when you tighten a halyard. The halyard pulls up on both the luff *and* the leech of a headsail. Therefore, it not only drags the draft forward, it also raises the clew with the result that you might need to move the lead aft to keep the sheeting position in the right place.

Unfortunately there are no absolutes. Every boat is different and all boats encounter different sailing conditions. No two waves are the same, and likewise no two crews are the same. Your main objective as a sail trimmer is to try and get the

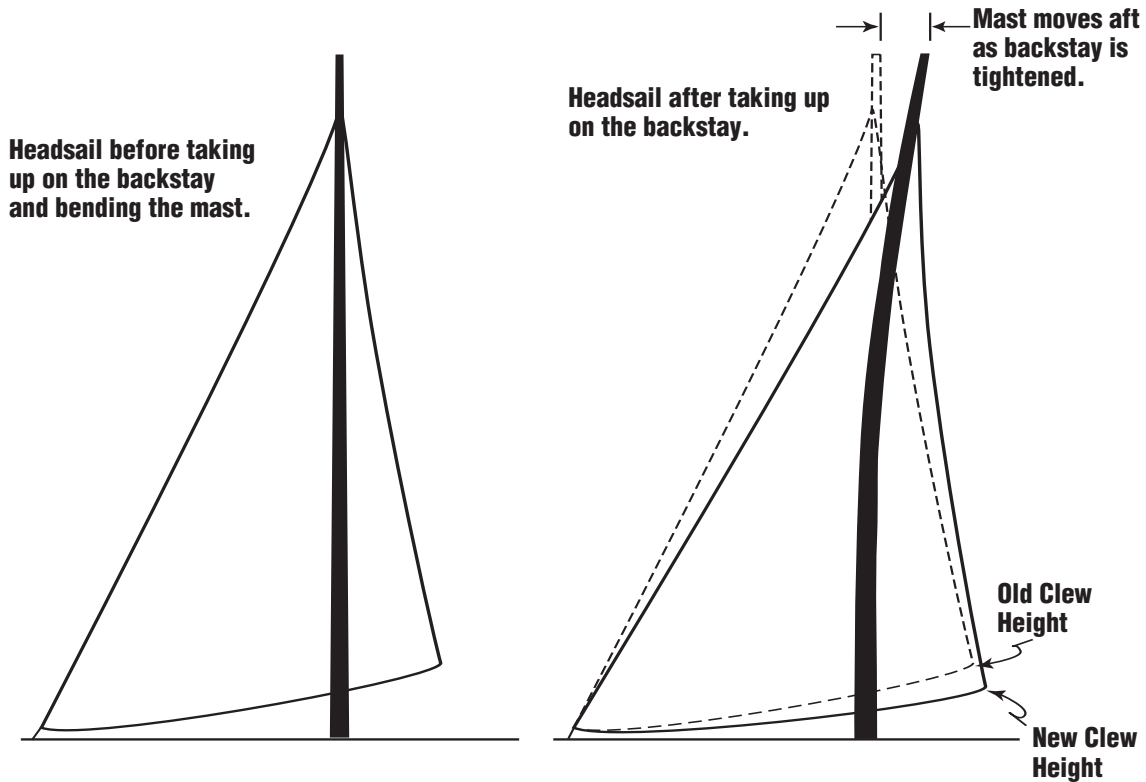

circulation around your sails going as quickly as you can and by extension your underwater foils, i.e., the rudder and keel. You will learn more about circulation and how it affects boat speed in the last chapter of the book, but for now understand that it's an important part of overall sail trim. After that your job is to keep it going for as long as possible. As this chapter unfolds we will take a look at sail trim for a variety of conditions. Because boats, crews, and conditions are so different you will need to understand the basics and tailor that knowledge to suit your own set of circumstances. For example, heavy boats with long, low-aspect keels respond differently than light boats with short, high-aspect keels. Specifically, the circulation gets going on high-aspect sails and appendages much more quickly than their low-aspect counterparts. Therefore, their sails need to be trimmed differently.

Racing sailors looking to eek every tenth of a knot out of their sails also have different priorities from the cruiser who wants his boat to sail well while he relaxes and cooks a meal or reads a book. Before we look at sail trim for different conditions we first need to understand some basics. For now we will confine ourselves to working sails.

Basic Rules

There are some basic rules you need to consider when trimming your sails:

- Rule No. 1** – You need to make more adjustments to your sails on light displacement boats than heavy displacement boats to keep the boat moving.
- Rule No. 2** – You need more powerful sails to move heavier boats, and vice-versa.
- Rule No. 3** – When in doubt, ease out.

Figure 11.3

When you wind the backstay on, you not only bend the mast, you move the top of the mast aft a few degrees. This movement will in turn have an effect on the clew height of the headsail.

Rule No. 4 – The part of the boat under water has a lot to do with how you trim your sails.

Rule No. 5 – The back end of your mainsail works with your keel to provide lift when sailing to windward.

With regard to rule No. 1, momentum has a lot to do with sail trim. Therefore, if you have an old-fashioned, long-keel, heavy, sea-kindly yacht, you can rely on inertia to keep you moving through the water once you have been able to get it up to speed. Subtle differences in wind speed and sail adjustment have little effect, and you do not need to be trimming constantly. On the other hand, a light, responsive, fin-keel boat will not be able to keep up speed if the wind drops or if it hits a wave and slows down. Those kinds of boats require a lot of “changing gears” to keep them moving well, and these gear changes are the result of the way you power up and depower your sails.

Rule No. 2 states that you need more powerful sails to move heavier boats, with power in this case being a function of draft, or the relative depth of a sail. Heavy boats need powerful sails to get them moving, whereas lighter boats can use flatter and less powerful sails to achieve the same results. In addition, flatter sails will allow them to point closer to the wind. Multihulls also have flats sails because they generate so much apparent wind. This difference in chord depth is important to understand, not only as it relates to the weight of a boat, but also as

it relates to how boats accelerate. At slow speeds all boats need deeper, more powerful sails to get them moving: As they accelerate, however, the sails need to be flattened. Deep sails generate more power because of this depth, but as speed picks up you need to flatten the sail so that the wind does not become unattached as it tries to bend its way around the deep curve in the sail. Again, that’s why multi-hull sails are generally flatter. They quickly generate apparent wind, and if the sails are not flat the air flow will become separated.

Rule No. 3 is an old standard. Most sail trimmers have their sails overtrimmed. It’s just one of those things. People tend to keep winding sails on harder, feeling that tight sheets must translate into more power and speed when in fact that loss of power is a result of forgetting to ease the sheet when the wind drops. As a result the sails are wound on too hard and it’s like putting on the brakes. Ease the sheet, let the sail fabric relax and the sail will resume its designed shape. Let the top twist open a little and nine times out of ten your speed will pick up. At times you need to have your mainsail and headsails trimmed on tight to narrow the angle of attack of the sailplan, for example, when you are squeezing up to make a turning mark or try-

Looking up the back of the mainsail on this multihull reveals a flat shape perfect for a boat that sails at high speeds.



ing to get above another boat. But most boats can't sustain these close angles and tight sails for very long, and you will soon have to ease out the sails out and resume a more normal course. If you find yourself overtrimming your sails to stop them flapping, there may be a problem with the design or the way you have them set. If you can't get your telltales all streaming together, the sail might need recutting.

Rules 4 and 5 go hand in hand. Most sailors do not give much thought to how they need to trim their sails to take advantage of what's below the water in terms of appendages. But in fact the relationship is a crucial one. Good foils can provide as much lift as good sails, assuming the sail trimmer allows them to function properly. The key is that there needs to be water flowing past the keel and rudder for them to provide lift, and the faster the water flows, the more lift is created. If the sail trimmer has the boat stalled because the sails are overtrimmed or trimmed improperly, there will not be any lift from the underwater appendages, and the boat will slip sideways. Of course, it's a delicate balance to get the right amount of lateral pressure exerted on the keel and rudder to get lift, but the potential results are such that it's worth the effort. A good example of the relationship between keel and sails can be seen when you are sailing to windward, so try this. Sail hard on the wind with your sails sheeted on tight and watch the boat track through the water. Now let your mainsheet out and watch what happens. Chances are the boat speed will not only pick up (rule No. 3 coming into effect) but the added speed will also be turned into lift from your keel and the result will be a better, faster track to windward. Be aware, however, that if you ease the mainsail out too much you will lose lift, and while the increase in speed will help your foils, the trade-off will not be an overall advantage and the result will be a loss in efficiency.

“Good foils can provide as much lift as good sails, assuming the sail trimmer allows them to function properly.”

The Importance of the Draft Location

Clearly the most important design feature of sails is the amount of draft since that translates directly into power. But the location of maximum draft is also very important, especially to racing sailors, since the leading-edge angle of headsails changes relative to the location of the draft in the sail. Specifically, as discussed in Chapter 6, the further aft the draft, the finer the leading-edge angle. Conversely, the further forward the draft, the wider the leading edge angle. Draft-aft sails with fine leading-edge angles will enable the helmsman to point closer to the wind and in smooth water this can be quite desirable. But there is a problem with this configuration in that it does not leave much room for error, and if the helmsman tries to “pinch” the boat, or point it too close to the wind even the slightest amount, it will not only cause the sail to backwind, but it will do so quite far aft in the sail and there will be an immediate corresponding drop in speed. On the other hand, with the draft forward the angle is greater, allowing much more room for error. Inexperienced helmsmen will prefer this more forgiving luff shape, and even experienced helmsmen like to have the draft forward when the seas are bumpy and steering difficult. For the cruising sailor, especially one sailing on autopilot, having draft-forward sails with a

“There is one important thing to understand about wind, that wind is energy and when it hits your sails some of that energy is used simply to fill the sails, or in the case of a spinnaker, to lift the sail so that it can fill and propel the boat forward.”

forgiving luff is most certainly a good thing. In fact, your sailmaker should take this into account when he designs the sail, and he should know if a boat will be sailed on autopilot a lot of the time.

There are two more points you need to consider when it comes to draft location. First, always remember that with sail trim, any action will have a corresponding reaction, and sometimes the effect might be bad for boat speed. For example, draft-aft sails mean that the back end of the sail will have more curvature than you might like and the air flow may become separated from the sail, causing it to stall. In light or moderate winds this is not a problem. But in a near calm or as the wind rises, it may be. Second, remember that because there are different wind speeds flowing across the sail from top to bottom, the location of the maximum draft will differ from top to bottom as well. Specifically, the draft down low will be further aft than the draft up high, because the increased wind up high will drag the apparent wind angle aft, meaning that you need a fuller luff entry. You need to understand these differences, but if the sail has been designed properly you should not have to worry about them. The sailmaker will have taken all of this into account; you need only to think about where to put the draft in general terms.

Trimming for Different Conditions

We are now armed with some basics that will serve us well no matter what kind of boat we are sailing or in what conditions we are sailing. Let's begin by looking at sail trim for sailing to windward, starting with almost nothing and seeing what happens as the wind increases in strength. We will then discuss what we should do to keep the sails trimmed properly and the boat sailing fast as the wind begins to build. The following points really apply only to racing sailors who are trying to gain an extra tenth of a knot of boat speed. But cruisers would do well to read and understand the techniques as well, and then apply them in a way that matches how they like to sail their boat. If you are a tweaker and a trimmer then by all means tweak and trim, but if you prefer a more relaxing sail then set up your sails as best you can and only adjust them when the need arises. These points are also broad and general enough that they will need to be refined to suit the kind of boat you are sailing. For example, if I discuss tensioning your backstays and your boat does not have a backstay, then try to see what the larger point is and how the same thing can be accomplished on your boat. To try to cover every possibility for every rig type and sailplan will end up being too confusing.

Calm (Under 5 knots) – There is one important thing to understand about wind, and that wind is energy and when it hits your sails some of that energy is used simply to fill the sails, or in the case of a spinnaker, to lift the sail so that it can fill and propel the boat forward. Therefore, if you are trying to sail on a calm day with a headsail or spinnaker that is either too large or too heavy, what little energy the wind may have will be expended on just getting the sail to set or getting the spinnaker to fill, leaving none to move the boat. Many sailors wrongly believe that sail area is the key to getting a boat moving. While this is the case when there is a steady wind blowing, it doesn't hold true when the wind is light. For light-air sailing you need light sails, and light means both light fabric and

small sails since a light sail assumes its designed shape more readily than a heavier one, i.e., it needs less wind to force the fabric into its designed shape. Without all the extra weight of fabric it will lift up and set more readily. This is the time you need to use your Windseeker – if you’ve got one – to generate any kind of speed, because as has already been pointed out speed creates apparent wind, and apparent wind is added to whatever other wind there is to your benefit.

When it’s calm:

- Use the Windseeker to generate boat speed, which creates apparent wind.

Very light air (4 to 6 knots) – Once the wind has begun to fill, or you have been able to create some apparent wind with the Windseeker, you can start to use your working sails to get the boat up to speed. Previously we have discussed powering up sails by adding depth and for sailors it’s a natural reaction in light winds to power up their sails as much as they can. Unfortunately this can be counterproductive. Your goal is to make it as easy as possible for the wind to flow on to your sails, and off again. If it’s really light and you have powered up your sails as much as you can, you might find that the wind does not have enough energy to make it around the point of maximum draft. It will get to that point and separate. On the other hand if your sails are a bit flatter the transition between wind flowing onto the sails and off the sails will not be as dramatic, and the wind will remain attached the whole time, thereby generating power. So in really light winds keep your sails on the flat side.

You can help your sails to set by moving your weight, and the weight of the crew, to leeward. This heels the boat a fraction and often this heel is enough to allow the sails to “fall” into their designed shape and set better. It also helps to move the weight forward. Modern racing boats have wide, flat aft sections and by moving all available weight forward and to leeward, the back end of the boat



Keeping crew weight forward and to leeward can help reduce the wetted surface by heeling the boat and lifting the stern out of the water. Less wetted surface results in more boat speed.

can actually come out of the water, reducing frictional drag and increasing speed. Gains in really light winds are incremental, but put one small gain on top of another and they can start to add up. Keep crew movement to a minimum so that the air flowing around your sails will have as much opportunity as possible to generate power without being disturbed. Remember that while there may not be any wind on the surface of the water, there may be some at the top of your mast. Be vigilant. In really light winds there can be wind shear caused by currents of air rising from the surface of the water affecting the light puffs of wind to which you are trying to trim. You might need to twist the sails more than normal to keep the boat moving. Your goal is to make it as easy as possible to get the wind onto and off the sails so be wary about having your sails wound too tight.

In very light air:

- Keep the sails relatively flat so air flow can stay attached.
- Move crew weight forward and to leeward.
- Watch out for wind shear and twist your sails accordingly.

Light air (6 to 10 knots) – Once you have at least 6 knots of true wind you should be generating some apparent wind of your own, allowing you to concentrate on sail trim and make fine adjustments as the wind fluctuates. This is the time that your sails should be fully powered up. The outhaul of your mainsail will be loose, adding depth to the bottom of the sail. The mast will be straight with the backstay eased, and the traveler will be at or above centerline, with the mainsheet all the way in. Be sure the top telltale is flying and resist the temptation to oversheet the sail. You would do better to concentrate on boat speed and let the lift come from the foils rather than trying to stuff the boat as high as it will sail. On both sails have the halyard tension just tight enough to remove any wrinkles, and be sure that the leechlines are loose and not causing the edges of the sails to cup.

At this point, the maximum draft in the mainsail should be roughly 48 to 50 percent aft, although when the conditions are light the points above take precedence and the reality is that the exact location of the draft is often a result of satisfying these other factors. In light winds the back of the mainsail can actually be curved a little like the flaps on an airplane, since this curve increases low-speed lift and makes the wheel more responsive by increasing weather helm.

In terms of headsails, the maximum draft can be as far back as 42 to 46 percent with a chord-depth ratio of around 18 to 19 percent. If you recall from the chapter on sail design, the leading-edge angle is important to the boat's ability to point. And when the wind is light, the sea is usually smooth, making for a good time to try to sail as close to the wind as possible. By allowing the maximum draft to be as far back as 46 percent, you are actually creating a narrower angle of attack while still being able to have a relatively full sail. The problem, of course, is that this draft aft tends to tuck the back end of the sail in toward the mast. But in light winds this round aft section does not present the problem it might when the wind is up where it might cause the air to separate from the trailing edge of the sail. Basically, you

“You would do better to concentrate on boat speed and let the lift come from the foils rather than trying to stuff the boat as high as it will sail.”

need to balance pointing ability against the power needed to move the boat. Keep the draft where you want it by adjusting the halyard tension, and be sure that once the wind comes up you tighten the halyard to move the draft forward again.

Remember when you are trimming for light winds that the vertical distribution of depth is not even throughout the sail. In Chapter 6 we learned about induced drag and discovered that keeping the bottom third of the sail flatter than the middle of the sail helps to keep this phenomenon to a minimum, which in turn increases overall lift. Many sailors are tempted to really power up the bottom of their headsails, which they can easily achieve by moving the sheet lead forward. But this is usually counter-productive as the extra depth aggravates induced drag, especially since the lead-forward position closes off the top half of the leech at the very time when you need to get the air off the sail as easily as possible.

In terms of steering, when the wind is light and patchy do not try to match its every change of direction. Keep a steady course and trim your sails rather than attempt to follow the breeze all over the ocean. Moving your rudder and constantly changing direction slows the boat. Also, be sure to keep the boat footing, in other words sailing fast, rather than pointing. Once the wind has filled in steadily you can begin to eke your way to windward.

Power up sails in light air by:

- Easing mainsail outhaul.
- Easing backstay.
- Easing halyards and cunninghams.
- Easing leechlines.
- Keeping main traveller at or above centerline.
- Allow headsail draft to move aft in order to create a narrow angle of attack.
- Keep lower third of sails flat to minimize induced drag.
- Keep the boat footing and minimize rudder use.

Moderate air (8 to 15 knots) – Once the true wind is blowing steadily over 10 knots you can get the boat fully up to speed and the sails trimmed perfectly to match not only the conditions, but whatever it is the helmsman wants to achieve. On racing boats, a constant dialogue and coordination between the helmsman and the sail trimmers is very important. This is when big gains in boat speed can be made. On cruising boats, while you don't need to constantly fiddle with your sheet or other sail controls, paying attention to what your sails are doing can mean the difference between an exhilarating beat and a frustratingly inefficient upwind slog.

As the breeze comes in, one of the first things you will notice is that it will cause the area of maximum draft in the jib and main to migrate aft. The fabric will start to stretch, and on many boats the halyards will begin to stretch as well. There will also be more sag in the headstay, which will hurt your pointing ability. In short, it's time to trim the sails.



The wind had increased, causing wrinkles to show along the luff of the headsail. The crew should increase halyard tension to remove the wrinkles and return the draft to the desired place.

You can start by taking up on the backstay and tightening the halyards or cunninghams. As the backstay is tensioned one of three things will happen; your mast will bend, your headstay will become more straight, or both. You need to decide how much of each you want to happen. To stop the mast bending so that all the tension can go onto the headstay, you need to take up on the running backstays, if you have them. This will keep the mast from moving, and as the top is pulled aft by the backstay, the headstay will become tighter.

First let's look at the mainsail. Flattening the sail by bending the mast is a good thing as the wind increases, but you can accomplish this in other ways and for the moment you might want to have the full effect of the backstay adjustment go directly onto the headstay. So, start to flatten the main by taking up on the outhaul, applying tension to the foot of the sail until it is at its maximum position, and then taking in on the flattening reef if you have one, bearing in mind that the amount will depend on the amount of heel your boat is exhibiting, along with the weather helm the helmsman is experiencing. For the moment the traveler will remain on centerline and there should be sufficient sheet tension to keep all the telltales flying perfectly. In practice this will mean trimming the sail until the telltales begin to dance around the back of the leech, and then easing it out a fraction, all the while keeping your top batten at or as close to centerline as possible.

Your objective at this point is twofold. You want to flatten the sail to reduce camber, which in turn reduces weather helm and heel, but you also want to keep just enough load on the sail so that the helmsman has a good feel for the helm. Remember if you decided to begin to bend the mast that you will also need to tighten the halyard or cunningham to keep the draft where you want it since pulling shape from the front of the sail not only flattens it, but also takes away the camber, leaving the remaining camber further aft.

In terms of the headsail, you should tighten the headstay to flatten this sail as well, but don't forget that this will cause the draft to move aft the same way that bending the mast does to the main, so be sure to tighten the halyard or take up on the cunningham. If the boat still feels overpowered you can move the lead position aft a few notches. This will further flatten the foot of the sail and add more twist to the top of the leech, depowering the sail and reducing heel. At this point you will notice that the top telltale will begin to lift before the rest. But if the boat is nearing the upper range of the sail and is beginning to feel overpowered, having the top of the sail lift early is not a problem since you will be intentionally spilling off power to reduce heel.

As the wind builds, change the sail trim by:

- Taking up on the backstay and halyards to move draft forward.
- Tighten the mainsail outhaul.
- Take up on flattening reef (if you have one).
- Sheet the mainsail until the top telltale stops flying, and then ease a fraction.

If the boat starts to become overpowered:

- Bend the mast more to flatten the mainsail.
- Lower the traveler a little.
- Move the lead on the headsail aft to allow the top to twist open.

Moderate to strong air (15 to 25 knots) – You have taken up on the backstay and added bend to the mast, tightened the outhaul and flattening reef (if there is one), used the cunninghams on both sails and started to twist open the top of the headsail. But you are still feeling a bit overpowered. That can only mean one thing: It's time to make some changes. For many sailors, especially those who are racing, either depowering the mainsail by lowering it down the traveler or taking a reef is far preferable to changing headsails. But on most boats, and especially cruisers, it's better for speed and pointing ability to make a headsail change because you need a flatter sail up front, one with the draft further forward and a smaller sail area. If your boat has a modern sailplan you might have non-overlapping headsails that are relatively small to begin with. In this case by all means reef the mainsail first. In most cases, however, before we get to that point we can use the main traveler to keep the boat sailing fast and balanced.

If you recall, the mainsail traveler allows you to keep the plane of the sail constant while changing its angle of attack, which makes it ideal for dumping a little extra power in heavier conditions since by keeping the tension on the leech and lowering the sail down it reduces helm while still providing lift. This is when it's very important to communicate with the helmsman aboard a racing boat. In fact, in many ways a good mainsail trimmer can actually drive the boat. If the trimmer reacts and lowers the traveler before a puff of wind hits the boat, the angle of heel will remain constant. If the opposite happens and the puff hits first, the boat will heel over (bad for boat speed), the bow will turn toward the wind (not good because the helmsman will have to turn the wheel hard to compensate), and there will be excessive leeway. Talk to the helmsman, let him know that a puff is coming, tell him that you are going to drop the traveler down and allow him to keep the boat sailing a straight course.

At some point the wind is going to increase to the point where you are sailing with the traveler all the way down, the headsail twisted open to reduce heel, and your sails flattened as far as they will go, and you are *still* overpowered. Now it's time to either change headsails or reef. You have reached the upper limit of your current inventory.

The crew on Titan are all sitting as far outboard as they can to help keep the boat level.



Strong air (above 25 knots) – Once the wind gets above 20 or 25 knots the objectives for racing sailors and cruising sailors start to diverge. Racing sailors need to keep on racing, so they will have to experiment with different sail configurations, configurations that will differ from boat to boat. Sail trim at this point becomes more a question of balance rather than precise sail aerodynamics. Providing you have got the right sails up the headsail trimmer might do better at this point sitting on the weather rail keeping an eye out for puffs rather than sitting down to leeward moving the sheet in and out an inch at a time. The mainsail trimmer, on the other hand, will still be working with the helmsman. It's important to keep the boat sailing on an even keel. Some boats like to sail heeled over and that's fine. But others prefer only a moderate amount of heel, and you will need to trim the sails so that the sailplan is not struggling against the rudder. A well-balanced boat will sail faster and more efficiently than one that is not balanced, and once the wind is up this balance should be your main objective.

Cruising sailors will also be seeking this balance to make life on board more comfortable and to take any strain off the autopilot. It may be that your particular boat is a yawl that sails best with a reefed headsail and mizzen. Then again you may have a cutter that balances best with a staysail and reefed mainsail. The point is that you need to experiment with different sail combinations and keep track of things like sea state, boat motion, and overall performance so that you can duplicate the settings in the future.

Communication between trimmers and helmsman is key:

- The mainsail trimmer can drive the boat by easing the traveller in the puffs.
- Unless you have non-overlapping headsails, consider changing headsails before you take a reef.

Sail Trim on Other Points of Sail

Now that we have got sailing to windward under control it's time to look at how best to trim sails when sailing on a reach or dead downwind. The actual mechanics of sail handling will be covered in the next chapter. But there's still plenty to talk about in terms of sail shape and controls. For now let's assume that you are still sailing within the limits of your sails and want to bear away at a mark, or around a headland, while still keeping maximum boat speed. Again, much of the following discussion will be in terms of boat speed on the race course. But these principals are just as relevant for cruisers, so stick with me and learn.

Bearing Away Onto a Reach: Headsails

The moment you bear away onto a reach, the angle of attack of both sails increases, and you need to alter the plane of each sail to take advantage of this change in angle. If you don't, the boat will immediately start to heel as the back end of each sail presents a stalled surface to the wind. For the headsail, the moment you ease the sheet the top of the leech will also begin to twist open depowering the sail. If you are bearing away onto a reach to set a spinnaker at a mark rounding on a race course, this inefficient way of easing out the headsail is probably acceptable, especially since you have many other tasks that need quick attention (like tending the new spinnaker sheet or topping lift), so the trade of a more efficient spinnaker set versus inefficient headsail trim is a reasonable one. But if you are bearing away onto a reach where you plan to stay with the same headsail, then you need to be prepared to adjust the sheet angle, ideally setting up an outboard lead in order to take full advantage of your sail. The best way to do this is to clip a block on the rail forward of the sheeting position of the headsail and run a second sheet through the block, attaching it to the clew of the headsail. Using the two lines you will be able to "float" the clew between the inboard position and the outboard one until all the weight is on the outboard lead and you are sailing on a reach.

Mainsail Control on a Reach

The mainsail is similarly eased, but with the boom, traveler, and vang, you can accomplish a controlled ease with a minimal amount of fuss. On a close reach you probably want to power up the headsail all you can by easing the sheet, moving the lead, easing the halyard, and easing the backstay. But with the main, depending on the amount of wind and type of boat, you will probably want to keep the sail reasonably flat so as not to induce weather helm. Only once you bear away onto a broad reach should you start to power up the mainsail.

Start the ease by lowering the main down the traveler. This will keep the plane of the sail in line with the new angle of attack, keeping the all-important back end of the sail working efficiently:

- Once the traveler is all the way down, start to ease the mainsheet.
- Apply some pressure on the vang to stop the leech of the sail twisting open.
- Ease the outhaul to power up the sail.
- Ease both the mainsail and headsail halyard.
- Ease the backstay.

“Sail trim at this point becomes more a question of balance rather than precise sail aerodynamics.”

Figure 11.4

Here is a basic look at wind angles and sailing terminology.

WIND DIRECTION

Again, while it's important to have the sails eased to enable the helmsman to steer a straight course, it's also important to have the sails working efficiently, and being able to control the leech of both sails is key to performance. Make sure that the telltales on the mainsail are streaming out behind the sail and ease the vang a little if the boat feels overpowered.

Downwind Sailing

At last the wind is at your back and the motion of the boat settles down to a gentle rhythm rather than the slap, slap, pound of upwind sailing. It is at this point that many racing sailors take their T-shirts off, unpack lunch, and discuss the after-race party, even though it is a time when sail trim is just as critical, if not more so than it is when sailing to windward. Similarly, many cruising sailors will choose this time to make a sandwich or open a book when even a minimal effort can result in big gains in both speed and efficiency. In Chapter 8 we took a look at how wind flows across and down a spinnaker, and came to realize that most spinnakers, even asymmetrical ones, are really just large, inefficient headsails when they are used on a reach, but that at a certain point there is a crossover when a large reaching spinnaker becomes more efficient than a smaller headsail sheeted to the rail. Where that crossover takes place depends upon many factors including the design of your boat, the skill of your crew, and the conditions in which you are sailing. Figure 11.4 provides a basic look at wind angles and sailing terminology. Again, it does not show precisely where a headsail should be dropped and a spinnaker raised since that will depend on your own circumstances, but it does give you an idea of wind angles and sails.

Control Lines for Downwind Sailing

Before we can discuss spinnaker trim we need to take a cursory glance at the control lines used to set the sail, and how they can be used to trim the spinnaker effectively. Let's first look at the control lines used to set and trim a symmetrical spinnaker.

Afterguy

In some parts of the world the afterguy, or “guy” is called the brace. This line runs from the cockpit on the windward side through the jaw at the end of the spinnaker pole and attaches to the clew of the spinnaker. The afterguy is used to rotate the spinnaker around to windward, and in conjunction with the sheet can be used to flatten the chord of the sail. On larger boats a “lazy sheet” is attached to the clew as well, but since the afterguy is doing the work, the windward sheet lies slack until the boat jibes. On smaller boats there will just be a single line that serves as either the guy or the sheet depending on the tack.

Spinnaker Sheet

On the leeward side, at least on bigger boats, the spinnaker sheet will be doing the work while a “lazy guy” attached to the same clew is slacked off also waiting for the jibe. Again, on smaller boats, a single line will serve both purposes. The angle at which the spinnaker sheet attaches to the sail is dictated by the position of the fairlead block, and it has a large effect not only on the draft, but also on the amount of twist in the leech. When spinnakers are used on a reach, the amount of twist is important in the same way twist in a headsail is used to reduce the power of the sail. In light winds keep the lead position forward, closing the leech and adding power to the sail. As the wind increases, gradually move the lead aft, depowering the top of the sail and reducing heel.

The afterguys are clearly visible on both of these boats holding the spinnaker pole aft.



The foreguy is keeping the outboard end of the spinnaker pole from rising.



Continue to do this until you get to a point when you are sailing in strong winds and want the lead all the way aft. This will flatten the foot and open the top of the sail.

Topping Lift

Attached to the end of the spinnaker pole is the topping lift. This is used to adjust the height of the outboard end of the pole, which in turn dictates how the luff of the spinnaker breaks. Just like on a headsail, it is important to get the luff to break evenly, in other words break at the same time along the whole length of the sail.

Downhaul or Foreguy

The downhaul works with the topping lift to control the luff of the sail, and like the name suggests, it holds the end of the pole down. This point should always be born in mind when changing pole angle, especially in heavy conditions. Literally hundreds of spinnaker poles have been bent or snapped over the years by overzealous trimmers trying to rotate the pole aft without first easing the foreguy.

Spinnaker Trim

Unlike a mainsail, which is attached at each of the three corners with two entire sides of the sail infinitely adjustable (by the mast and boom), and the headsail, which is also attached at three corners with one entire side adjustable (by the headstay), the spinnaker is attached only at the corners, so manipulating shape within the sail is therefore much more difficult. That's not to say that it can't be controlled, just that it's a bit more of a challenge. Note that with the spinnaker, as is the case with the main or jib, the chord is an imaginary line that runs between the clews, and by extension, the leeches. The chord depth is the distance from this line to the deepest part of the sail.

Manipulating Spinnaker Shape

There are four main ways you can manipulate spinnaker shape:

- You can control the overall chord depth or draft in the sail by bringing the clews closer together or moving them further apart.
- You can raise or lower the outboard end of the pole to control the depth in the top half of the sail.
- You can manipulate where the draft falls in the sail by raising or lowering the outboard end of the pole.
- You can change the angle of the spinnaker pole relative to the apparent wind direction

Let's look at each of these different means in greater detail.

Changing Chord Depth

In some ways you actually have more control over the chord depth of spinnakers than you do the other two sails since by bringing the clews, and by extension the leeches, of the spinnaker closer together, you can dramatically increase the overall chord depth of the sail (Figure 11.5). Conversely, moving the clews apart flattens the chord depth. You accomplish this by leaving the sheet position where it is and squaring the pole, leaving the pole where it is and either tightening the sheet or moving the sheet lead aft, or doing both.

Raising or Lowering the Pole

You can also control the chord depth of the top half of the sail by raising or lowering the height of the pole. If you lower the pole it tightens the luff, which then cups in toward the leech adding depth to the sail much the same way bringing the clews together does. Because the clews remain the same distance apart, the added depth is limited to the top half of the sail.

Manipulating the Draft

As already pointed out, spinnakers can be viewed as large, inefficient headsails and as such you might want to manipulate the location of the draft. Again, you can do this by raising or lowering the pole. If you lower the pole it stretches the luff of the sail and in effect pulls the draft forward. Raise it and the draft moves aft. This is a

Figure 11.5

By bringing the clews of the spinnaker closer together, you can dramatically increase the overall chord depth of the sail. Conversely, moving the clews apart flattens the chord depth.

SPINNAKER FROM THE TOP OF THE MAST

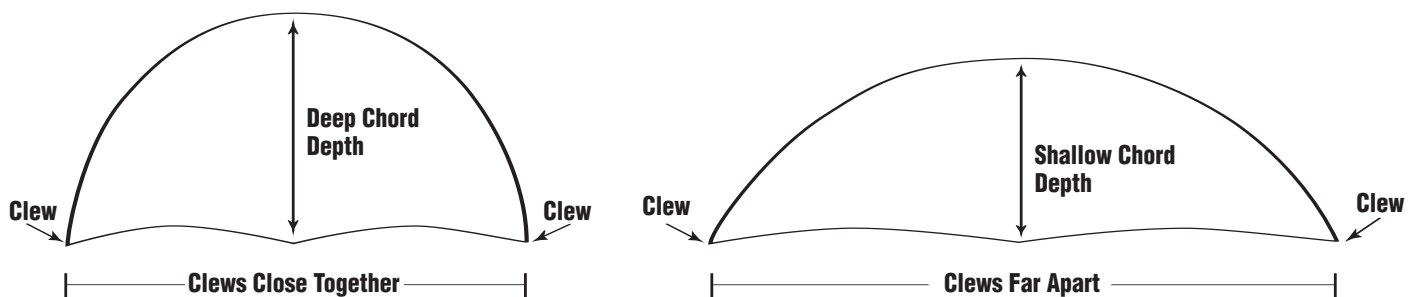

Figure 11.6

When the apparent wind is aft of 120 to 130 degrees off the bow, keep the pole at right angles to the apparent wind.

very important adjustment because you are not only moving the point of maximum draft in the sail, but changing the shape of the leading edge of the sail. Earlier in this chapter we discussed how much easier it is to sail with a draft-forward headsail since the wider angle of entry makes for a much more forgiving sail. The same is true for spinnakers. When you are reaching, having the draft pulled forward by lowering the pole makes it easier for the helmsman to steer the boat without the spinnaker collapsing, although you have to be careful not to put too much fullness in the luff causing it to stall. On the other hand, having the draft slightly aft might allow for better attached flow across the sail (remember that when reaching most of the flow is attached). It might cause the leading edge to be a bit unstable and require more sheet tension to stop it from continually breaking, but if the conditions warrant it, consider raising the pole and dealing with a finer angle of entry.

The Angle of the Spinnaker Pole

The last point actually has less to do with controlling sail shape and more to do with general spinnaker trim. You need to change the angle of the spinnaker pole relative to the apparent wind direction, and there are some basic rules of thumb to follow:

When the apparent wind is aft of 120 to 130 degrees off the bow, keep the pole at right angles to the apparent wind (Figure 11.6). This will allow for the maximum projected area. When sailing on a broad reach and run it's all about projected area. But be careful not to flatten the sail too much by over-squaring the pole. You will be gaining projected area, but you will also be destabilising the sail, causing it to collapse easily, since at some point the wind will stop flowing across the sail and begin flowing down the sail. Keep the clews level, allow the sail to lift as high as it can, and be careful not to overtrim it.

When the wind is forward of 120 degrees over-square the pole (Figure 11.7). In other words, the angle between the pole and apparent wind direction should be less than 90 degrees. With the wind further forward you are sailing on a reach, and you do not want to have the sail too full. By over-squaring the pole you are effectively flattening the sail and making it more efficient for reaching. A full sail will only contribute to the heel of the boat, and also to leeway.

With headsails and mainsails it is fairly easy to set up the sails for the conditions and know exactly how the boat will respond. Spinnakers, on the other hand, are a lot more complicated. They are big, powerful sails affected by many variables. Light nimble boats that surf easily need a forgiving luff to accommodate the sudden increases in speed. Rather than trying to rely on a single set of criteria, you will do better to experiment with your boat and try to determine which settings work best for which conditions. Having an understanding of the basics and building on them is very important.

Spinnaker Handling in Heavy Winds

One of the areas where large gains can be made, as well as where spectacular wipe-outs can occur, is running downwind in strong winds. It's not as hard as it looks, but it does require teamwork and co-ordination to pull it off success-

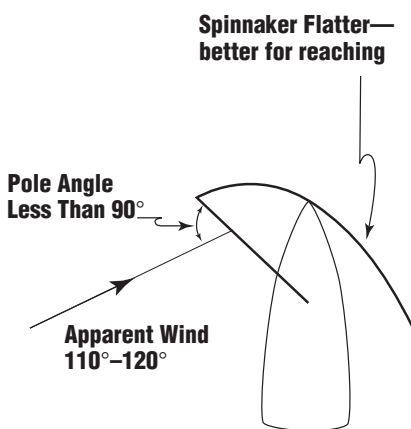
**Figure 11.7**

When the wind is forward of 120 degrees the angle between the pole and apparent wind direction should be less than 90 degrees in order to flatten the spinnaker.

fully. As previously mentioned, it's important to mark sheets, guys, and hal-yards so that you can pre-set the running rigging before you deploy a spinnaker. This is doubly important in heavy air. You want to be sure that when a spinnaker fills you do not have the sheet too tight, otherwise you will round up and broach. If you have marked the rigging and noted the settings you should not have any problems.

Just as with jibing in heavy winds set the spinnaker when you are on a surf, when the apparent wind is reduced by your forward motion. In one quick move, hoist the spinnaker, bring the pole aft, and as soon as possible get the crew weight aft and to windward. Crew weight is very important when sailing downwind in strong conditions. If you are not sailing dead downwind, but rather more on a reach, be sure to have all your crew as far aft and to windward as possible. Lead the spinnaker to the windward side to avoid having a trimmer down to leeward.

Communication between helmsman and spinnaker trimmer is vital to keeping the boat on an even keel. The helmsman will be the first to feel problems developing through the load on the wheel. If the boat is sailing more on a reach than a run, i.e., with the wind forward of 150 degrees apparent, there will be a chance of the boat rounding up if it gets overpowered. The driver will start to feel the load on his rudder and will have to turn it to compensate. If he turns it too much the water flowing past the blade will become detached, and when that happens he will lose all control. As soon as the helmsman feels the boat starting to round up he must notify the spinnaker trimmer right away, and the trimmer must respond by giving the sheet a quick and decisive ease. Some trimmers are reluctant to ease the sail because they see the leading edge of the spinnaker starting to curl and instead they call for more sail trim. This will only spell disaster as the added trim pulls the center of effort on the spinnaker further aft forcing the boat to round up into the wind. A quick ease on the sheet will allow the helmsman to ease up on the wheel just long enough for the water to reattach itself to the blade and regain steerage. He can bring the bow down again and the sail can be re-trimmed. It's better to have the sail collapse temporarily than have the boat round up into a wipe-out and have the spinnaker collapse anyway.

The danger when sailing on a run (wind aft of 150 degrees apparent), is that there is a possibility of the boat sailing by the lee and accidentally jibing. This usually happens when the spinnaker starts to oscillate and the helmsman tries to chase it around, finally ending up in what's called a Chinese jibe. It's important to keep the spinnaker under control by moving the sheet lead forward to have a short, snug attachment on the clew. Some sailors will in fact fly the spinnaker off the lazy guy since the position of the guy is usually much further forward than the spinnaker sheet. It's important to spread the clews to flatten the spinnaker so that there is no chance of it oscillating, but you need to be careful not to flatten the sail too much since flat spinnakers are more susceptible to collapsing than when full. Finally the helmsman should not try to chase the sail around; this only causes more problems. If the boat starts to get into a roll, notify the trimmer and immediately head five or ten degrees toward the wind to bring the apparent wind

“Communication between helmsman and spinnaker trimmer is vital to keeping the boat on an even keel.”

“If you have ever sailed with a top crew on a competitive boat, you will have noticed one thing. The crew, the boat, and the sails all seem to work as one.”

forward. Sailing downwind in heavy air is a delicate balance, but not a difficult one providing there is communication and bold, decisive moves on the part of the helmsman and sail trimmers.

Advanced Sail Trim for Racers

Up to this point we have discussed the controls that can be used to manipulate sail shape. We have also discussed when and how we need to change the shape of the headsail, mainsail, and the spinnaker. Now we can take what we have learned out onto the racecourse and see how we stack up against the competition. This really is the fun part. Even if you aren't a racer, you will find this interesting since many of the techniques used on the racecourse can be helpful when out cruising as well.

If you have ever sailed with a top crew on a competitive boat, you will have noticed one thing. The crew, the boat, and the sails all seem to work as one. In fact, a good crew views all these vital components as one, and you need to think the same way. When you make any kind of adjustment to any one part of the boat, it has an effect on the whole boat. If one of the crew leaves the weather rail to go and make sandwiches, the mainsail trimmer might need to flatten the main to compensate for the extra heel. If a new helmsman takes over, the headsail trimmer might “round out” the front of the genoa to give the helmsman more latitude for steering until he gets into the rhythm. If the seas are choppy, constant communication between the helmsman and the crew is necessary to keep the boat moving as fast as possible, or for getting it back up to speed if it hits a wave and slows down. It's all about communication and coordination. With that in mind let's go racing. The best way to look at advanced sail trim is to sail around a triangular course and see what happens along the way.

Pre-Start

This is a time for the sail trimmers to be planning and anticipating the first few legs of the race. Might there be a need for an outboard lead on the genoa? Is the breeze building? Will the crew have to throw in a reef? What are the settings for luff and outhaul tensions? Check your notes and make sure that the sails are set up for perfect trim the moment the start gun fires. Ask the navigator what the apparent wind speed and angle will be once you get around the top mark and think about what spinnaker you will need. If you can anticipate changes before they hit you, you will be much better prepared to deal with them. Keep your sails powered up: outhaul off, lead forward, and so on if the helmsman needs the power, but remember that it's more important to have the sails trimmed perfectly when the start gun fires rather than in the pre-start maneuvers. The helmsman is going to need all the power and speed he can get to place the boat exactly where he wants it when the gun goes off and it's time to go charging across the line. As sail trimmers you can also play a big part in helping the helmsman steer the boat. If he is trying to come up into the wind as quickly as possible, make sure that the mainsail is sheeted on since the back end of the sail will force the bow up into the wind. If the helmsman has to duck another boat it's entirely up to the

Before the start:

- Think ahead and set up the deck layout accordingly.
- Keep the sails fully powered up.
- Help the helmsman turn the boat by trimming the mainsail.
- Know what wind angle and speed to expect when you round the top mark.
- Get the spinnaker for the downwind leg ready by the hatch.

mainsail trimmer to make sure he can bear away, especially if the boat has a big mainsail. Your goal in all of this is to hit the start line on time, sailing fast, and with all sails set perfectly for the conditions.

Windward Leg

Once the gun has gone off and the crew has settled down, it's time for the communication between the driver and the trimmers to begin in earnest. The trimmers must know what the helmsman is thinking since only he can feel the trim of the boat through the helm. If there is a neutral or lee helm, he will need more mainsheet trim or traveler up. Conversely, if he is starting to fight the helm, it may be time for the traveler to be eased down a couple of inches or the outhaul taken all the way out. A good main trimmer can really drive the boat. Keep tweaking the backstay to make sure that it is right for the conditions and keep all the crew weight where it balances the boat best. Appoint one of the crew sitting on the rail to look for puffs and to call out to the helmsman when one is approaching. Going up the windward leg you need to know if the helmsman is in a "footing for boat speed" mode, or a "pinching to point" mode. At times, speed and lift from the foils is what's needed; at other times the helmsman will try to gain as much distance to weather as he can. Let's look at these two points of sail separately.

Finding Speed

Often a boat is not up to speed. This can happen after hitting a square wave, finding a light spot in the wind, or at the start when boats are jockeying for position. Any time the speed is down, you are giving up not only distance toward the mark, but also lift from the underwater appendages and from the sails. You need to get the boat back up to speed as quickly as you can, and you do so by powering up the sailplan. Your aim is to accelerate the flow of wind over the sails, which in turn increases the driving force that is associated with lift. So how do you accomplish this? Power up the headsail and mainsail, increase the angle of attack of both sails, and create a lift-promoting shape in the mainsail.

Power up the headsail by easing the sheet, moving the lead forward a fraction, and possibly easing the halyard and backstay. All of these adjustments quickly add power to the headsail. Do the same for the main, although be careful when you ease the backstay that you don't tighten the leech of the mainsail too much (remember the top of the mast will be moving forward relative to the mainsheet) since that will cause it to cup around, stalling the wind and quickly killing your speed. The helmsman can also increase the angle of attack of the

“It’s a fine line between powering up and pointing, but a coordinated crew can work magic if it’s done right.”

sails by bearing away a few degrees. If you keep the sails sheeted in and have the helmsman bear off a fraction, the increased angle of attack will immediately translate into boat speed.

Lastly, look at the overall shape of the main. Is the shape uniform and deep enough to accelerate flow? If the mainsail looks flat and the draft is too far forward, ease the outhaul and the halyard tension. Let the fabric relax and the sail will resume its designed shape, helping to promote speed.

If this powering-up has been coordinated and decisive, the boat will soon begin to accelerate, the air will start flowing across the sails and the water will start flowing across the foils. As this happens be ready to reverse your actions, since as soon as the boat is back up to speed the angle of attack will be reduced along with the apparent wind angle. Make sure your sails are not too full and round, otherwise, the increased apparent wind could become separated when it reaches the deepest part of the sail, and the air flow will stall. Tighten the outhaul on the main, bring the lead aft on the headsail, take up on both halyards and the backstay, and trim in the sails to make them flatter. If you have running backstays, ease them out, bend the mast, and flatten the sail.

Gaining Height

Once you are up to speed with flat sails, the helmsman can, if he chooses, gain some distance to weather. If the move is coordinated between helmsman and trimmers, the driver can pinch the boat for a few seconds gaining valuable height to windward without any real loss in speed. As the bow comes up, the main trimmer will bring the traveler up above centerline and the headsail trimmer will move the lead aft and tighten the sail. For a short while the windward telltales will dance and protest, but a combination of the momentum of the boat and the tight sails will allow you to point above close hauled. Be ready, however, for when the bow comes back down again. Speed will have been burned off and you will need to adjust your sails accordingly. It’s a fine line between powering up and pointing, but a coordinated crew can work magic if it’s done right.

Foot for speed by doing the following:

- Power up both mainsail and headsail.
- Ease the sheets a little and let the sails breath.
- Increase the angle of attack on sails by bearing off a little.

Gain height by doing the following:

- Bring traveler above centerline.
- Move the headsail lead aft.
- Trim both sails on hard.
- Narrow the angle of attack by pointing closer to the wind.

Fine-Tuning for Waves

As so often happens on a race course, the wind will blow from the same direction for a few days building up a small sea, but by the time you get out there to race it will have shifted a few degrees. The result is that on one tack you will be sailing directly into the waves, while on the other tack you will be sailing with the waves on your beam. If this is the case you will have to trim your sails differently on each tack.

With the waves on the bow, for example, you will need power to punch through them. Furthermore, trying to sail too high can be a risky business as you may be in danger of hitting a wave head on and losing all boat speed. With this in mind, keep your sails powered up with a touch more twist in them to keep the air flowing over the sail. Be ready to ease the sheet and build speed if a wave stops the boat, and keep the adjustments continual as you eek an extra tenth out of the boat.

On the other tack, there will be no danger of hitting waves, so you can keep your sails flatter and less twisted. With essentially a “kind” seaway, the helmsman can point and pinch as much as he wants to gain some distance to windward, so bear this in mind when you are setting the boat up and trimming the sails.

When sailing into waves:

- Keep sails powered up.
- Twist sails more than normal.
- Foot for speed.

When there are no waves:

- Keep sails flatter with less twist.
- Point and pinch to gain some height to windward.

The Downwind Leg

As soon as you reach the top mark it will be time to change the aspect of the boat. Bearing away will not only change the angle of attack on the sails, it will also dramatically reduce the apparent wind speed. It’s time to power up the sails. Projected area is what you’re after and powerful sails that allow the wind onto them easily, and off them again easily, is what it’s all about. Ease the halyards, ease the backstay, ease the outhaul, and set the vang so that the top batten is parallel to the boom. Trim the spinnaker, keeping in mind the points made earlier, and keep making small changes watching all the while what it does for your boat speed.

In Summary

Good sail trim is all about understanding the basics, knowing what it takes to move a boat through the water, tweaking your sails to gain the smallest advantage, coordinating the moves with the helmsman, and then doing it all over again.



Both of these crews are working together to get the most performance out of their boats.

Don't forget the underwater appendages and know that communication is key. Also keep in mind the fact that nothing makes you look more like a tactical genius than good boat speed. Unfortunately, speed alone won't win you races. Tactics and sail handling also play an equal part. In the next chapter we will look at how to handle your sails. To many, these huge pieces of engineering look unwieldy and daunting. But with a bit of finesse and some common sense we will soon have you handling sails like a pro.

Chapter 12

SAIL HANDLING

Techniques for Managing the Unmanageable

Sails are unwieldy, and without modern mechanics they would be almost impossible to handle. Fortunately, we are well past the days of simple block and tackle, and with hydraulics, multiple-speed winches, and low-stretch, high-strength lines, we can tame just about any sail on any size boat. Taming a sail and handling it well, however, are two different things, and this chapter will focus on the latter. Both racing and cruising sailors will benefit from knowing how to set and douse a spinnaker, how to reef a mainsail, and how best to furl a headsail. First we will tackle the interesting subject of spinnaker handling, dividing it into two categories: cruising and racing techniques. Then we will delve into the realm of working sails – reefing and tacking, dousing and hoisting—since there are plenty of tricks to doing these things well, whether cruising or out on the racecourse.

Spinnaker Handling Techniques for Cruisers

Many cruising sailors view both symmetrical and asymmetrical spinnakers with trepidation. It's not setting the sail that strikes fear into their hearts. It's getting it down. Using spinnakers mirrors much of sailing—it's all about technique and planning, about knowing the end result of all actions. For example, if you ease

A nimble foredeck hand is necessary on a racing boat.





This spinnaker is being hoisted with the sail stopped with yarn.

a spinnaker sheet it not only deepens the sail, it also destabilizes it, which is not a problem if you are expecting the result, but which can be more than a little alarming if it takes you by surprise. In order to make setting a spinnaker easier and safer, there are a number of devices you can use to tame the sail while it is being set. Bear in mind that it's hard to be specific about different techniques for different size boats without making the whole issue too confusing, so the following sections are general. You need to decide, given your boat size and level of experience, which techniques will work best for you.

Stopping a Spinnaker

Unless you are setting the lightest of spinnakers or on a fairly small boat, the sail should be in stops or in a spinnaker sock. Stops are either elastic bands or light pieces of yarn that are used to lash the sail to keep it from catching wind and setting prematurely. Larger boats (or spinnakers that are going to be set in a lot of wind) should be stopped with yarn. The yarn is more time consuming, but definitely worth the effort. It is the only safe and secure way to ensure that the spinnaker does not open prematurely.

Using Bands as Stops

This is the easiest way of stopping a spinnaker. To band the sail use the following procedure:

1. Buy a sturdy plastic bucket and cut the bottom off.
2. Take regular household rubber bands and pull them over the open end of the bucket until you have a few dozen bands loaded.
3. Starting at the head of the spinnaker, pull the sail through the bucket releasing a band every two feet or so. The bands will snap around the fabric keeping the sail from opening when you are setting it.
4. Stop banding the sail six to eight feet from the clews to allow them to be spread when you are hoisting the sail.
5. If the spinnaker is light you can leave the clews as they are, but if you anticipate wind, you might consider banding the clews as well as the rest of the sail. To do so pull each clew through the bucket releasing bands as you go.

Once you have finished banding the sail it should look well trussed. Your main objective is to ensure that the spinnaker can be hoisted all the way to the top of the mast and the sheets and guys set before the wind catches the sail and begins breaking bands.

Using Yarns as Stops

Larger spinnakers, or those that might be set in stronger winds, need to be tied with yarn and carefully hand-folded. When I raced the Whitbread in the days of IOR maxi-boats the spinnakers were over 5,000 square feet in area, and we set them in 30 to 40 knots of wind. We had to be sure that the spinnakers were packed with the same care a pilot would pack his parachute.

Before you stop a spinnaker with yarn, you need to first prepare it by making some marks on the sail:

1. Ensure that the corners of your sail are properly labelled as head and clew.
2. Along the leeches put small arrows pointing toward the head of the sail. This will help you untangle the spinnaker when it gets dumped below after a sail change.
3. Measure the foot of the sail, divide it in half and make a mark.
4. Using a waterproof marker, make a mark on the leech of the sail up from the clew. The distance will be the half foot length that you just calculated.

To stop the sail use the following procedure:

1. Start by running the leeches. Begin at the head and (making sure that there are no twists in the spinnaker) work your way down the sail until you get to the clew.
2. Starting at the head again and keeping the leeches together, start folding the body of the sail in toward the leeches. Keep the fold as neat and tight as possible.
3. Using household yarn, wrap it around the spinnaker and tie it off securely.
4. Move down the sail three feet and tie a second stop and so on until you get to the pre-marked point on the leech. (The point that is half the foot length up the leech).
5. Stop each “leg” beginning at the clew in the same way you stopped the leeches.
6. Once you are done, the whole sail should be neatly tied with no loose piece of fabric dangling in search of an errant puff of wind.
7. Stuff any loose piece of nylon into the folds, otherwise it will catch the wind and foil your plans if given half a chance.

If dealing with buckets, bands, and spools of yarn is not your idea of a good time consider a sock. There are two kinds of socks: one that is used for packing and setting a spinnaker, and another that functions as a dousing sock and is used for both setting and dousing a spinnaker. Racing sailors will be familiar with the former, cruisers the latter. While a dousing sock sounds like a better option for all types of sailors, it involves a fiberglass hoop and a bunch of control lines that make it too heavy and unsuitable for racers to consider. Let's look at the racing option first.

Figure 12.1

Some spinnaker socks are full-length contraptions that are equal in length to the spinnaker leeches.

Figure 12.2 (far right)

Others are shortened versions with a diaper.

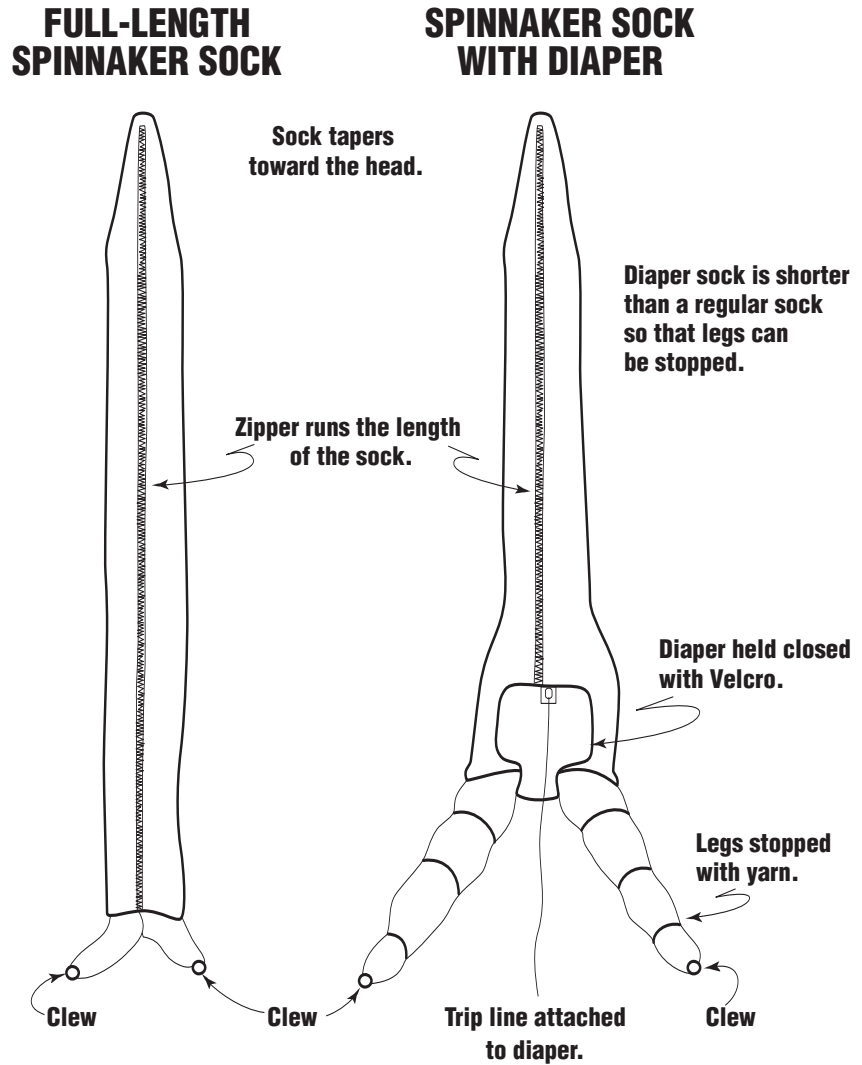

The Spinnaker Sock

Some spinnaker socks (Figure 12.1) are full-length contraptions that are equal in length to the spinnaker leeches. Others are shortened versions with a diaper (Figure 12.2). The latter type is made from a light nylon and is closed by a zipper that runs its length starting at the head of the sail and working down toward the leech. Just as we ended the leech stops half the foot-length up from the clew when banding a spinnaker, the sock ends at the same place. This is because for spinnakers that will be used in stronger winds it's desirable to be able to set the pole and sheet where you want them before the spinnaker fills with air, and the only way you can achieve this is if the clews can be pulled apart with the legs stopped separately with wool or bands, and the diaper there to hold the body of the spinnaker in the sock as you hoist the sail. After this has been done you pull on a trip line attached to the diaper, the body spills out, the zipper breaks open and the sail sets. For its part, the sock comes floating down to be retrieved and used again.

The only difference with the full-length version is that the sock runs all the way from the head to the clew and there is no need for a diaper. The obvious

A dousing sock makes handling a spinnaker much easier.



drawback is that the clews cannot be spread apart before the sail fills with air. This is fine for light spinnakers used in gentle breezes since you don't have to worry about separating the sheet and guy set before the sail fills to avoid having it become a wildly gyrating, uncontrollable piece of nylon.

The History of the Spinnaker Sleeve

The first spinnaker retaining device was invented in Germany about 35 years ago. It was called the Blue Max and was a very simple cloth tube with a rigid opening at one end and a closed-loop line running along the inside that was used to control the up and down of the tube. Nobody paid much attention to it back then since flying spinnakers was not very popular at the time.

Then along came Eric Tabarly, the French singlehanded sailing ace who recognized the need for such a device and asked his sailmaker, Viktor Tonnerre, to make him one for the 1976 Observer Single-handed Transatlantic Race, or OSTAR. Tabarly hoped that the spinnaker sleeve would allow him to sail his yacht Pen Duick singlehanded with a spinnaker. And when Tabarly won the race, the spinnaker sleeve was credited with his success and the public became formally introduced to this innovative device. Soon thereafter every sailmaker in France was building his own version.

In the United States two companies – Mack-Shaw Sailmakers in Fort Lauderdale, Florida, and Cruising Systems of Marblehead, Massachusetts – were credited with making the first serious attempt at the modern spinnaker sleeve on this side of the Atlantic. In fact, the two competitors' early spinnaker dousing devices were very similar to each other. Unfortunately, in both cases, the devices were made out of spinnaker cloth or bag material, which would cling to the sail when wet making it difficult to hoist. The lines were also too small, so that they burned the users' hands and could foul and wrap around the spinnaker. In short they were unreliable and unsafe, even when handled by an experienced crew.

Eventually sailor-turned-sailmaker Etienne Giorre decided to take it upon himself to create the perfect spinnaker sleeve, in the process implementing a number of innovative ideas that solved the problems faced by the earlier systems. For example, Giorre created a separate channel for the control lines that kept them apart from the sail at all times. Next, he addressed the mouth of the sleeve by manufacturing an oval fibreglass hoop that was light but strong enough to remain open when pulled against the sail and slippery enough to go over the sail without chafing the fabric and stitching. Finally he addressed the problem of the wet material sticking to the sail by having a fabric specially woven for the socks called a "tricot," a meshlike material that dries easily, is light and strong, and most importantly of all, does not hang up on the spinnaker when wet. Today, having manufactured over 10,000 sleeves for all sizes of boats ranging from the 156-foot yacht Hyperion to small daysailers, Giorre has been credited with revolutionising the way spinnakers are used by everyday sailors.

DOUSING SOCK

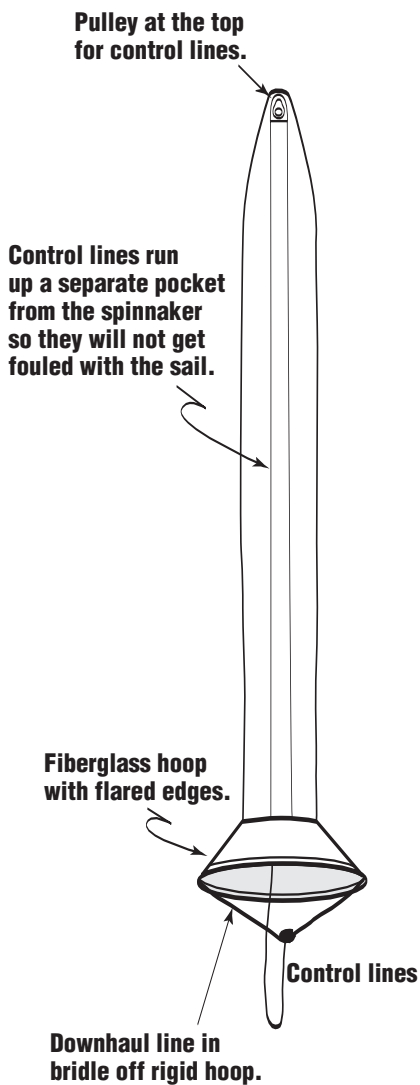

Figure 12.3
Dousing Sock

The Dousing Sock

This invention has done for the cruising spinnaker what roller-furling did for cruising headsails, i.e., made the sail more manageable and less intimidating (Figure 12.3). The dousing sock is similar to the spinnaker sock except that it does not have a zipper. Instead, the sock is pulled down over the sail with a rigid fiberglass hoop that collapses the spinnaker and feeds it into the sock. The hoop has flared edges, and when a takedown line is pulled it gathers the spinnaker fabric and the sock slides down the sail until the spinnaker is completely doused and ready to be lowered. Control lines run in a separate pocket from the spinnaker, and include lines that are used both to hoist the hoop when setting the sail and lower the hoop when the sail is doused.

The Spinnaker Turtle

Yarns, rubber bands, the spinnaker sock, and dousing sock are devices generally used on larger boats, say 30 feet and longer. On smaller boats it's not necessary to go to all this trouble because the spinnakers are much easier to manage. That's not to say you should not be careful, but you most certainly do not need to stop the spinnaker on a Hunter 26. Instead you should launch it from a spinnaker turtle, basically a round bag with a plastic hoop at the opening and a cover that has a bungee around the edges so that it can be pulled over the hoop and held in place. Pack the spinnaker by running each tape, luff, leech, and foot individually to ensure that the spinnaker is not twisted, then hold the tapes together as you stuff the body of the sail into the turtle, keeping the foot and leeches on top. A good spinnaker turtle will have ties or Velcro straps that you can then use to tie off the head and clew patches so that even after the sail is dumped below and bounced around, you can easily find the three corners when you need them. When it comes time to hoist the sail the turtle clips on to the lifeline where the foredeck hand can attach the halyard, sheet, and guy to the spinnaker, and pull the cover closed again until the crew is ready to launch. A yank on the halyard will pop open the cover and if you have flaked the sail into the turtle properly, the sail will set without a hitch.

Setting a Spinnaker

Now that you have all your gear in place it's time to get ready to hoist the sail. First, the leeward sheet and the lazy guy (if the boat is rigged with one) are run aft to a turning block, and the afterguy and lazy sheet are led around the windward side of the boat. While doing this, the afterguy is led through the beak, or jaws of the spinnaker pole, through a turning block on the windward side and to one of your largest winches. When the spinnaker is set there will be a lot of load on the afterguy, much more so than on the sheet, so be sure to use your biggest winch. Also be sure that all guys and sheets are run clear of all other running rigging and *outside* all stanchions and shrouds, as opposed to jibs sheets, which are run on the inside. Otherwise, the sheet or guy will get hung up, which can result in disaster if the sail is under load. If you are using a pole guy, i.e., a separate piece of rigging that is used expressly to keep the spinnaker pole back from the headstay, then you

can hoist the spinnaker pole with the topping lift and square it aft with the pole guy while the spinnaker is still in its bag. Otherwise you cannot bring the spinnaker pole aft without dragging the spinnaker out of its bag and risk having it fill with wind. Racing sailors are willing to take this chance, and in fact, most crews are well trained to cope with a premature set. But it's not worth the trouble if you are cruising, which is one reason why many cruisers rig this additional line.

With a pole guy in place and the spinnaker either in stops or in a spinnaker sock with a diaper, it's time to trim the sheet and guy until the windward clew is at the end of the pole and the leeward clew is well aft so that the two are separated before any wind gets into the sail and causes it to fill. The spinnaker is then hoisted to the masthead, and when everyone on board is ready, the diaper is opened allowing the body of the sail to escape and fill. If the sail is in stops, a few sharp tugs on the clew should break the first band and the rest will soon follow. Be prepared, however, for the fact that the wind alone will sometimes be enough to break these stops and it may begin to open before it is fully hoisted. The beauty of having the clews pre-set is that as soon as the spinnaker fills with wind it will be properly trimmed, and the boat will be balanced. There will be no mad scramble to get the pole up and aft and the spinnaker sheet trimmed correctly.

Steps for setting the spinnaker

- Visualize what the sail will look like when it's flying.
- Keep the spinnaker lines on top of those used for the headsail, under the leeward running backstays and outside the shrouds.
- Lay the spinnaker on the foredeck on the leeward side.
- Run the sheets and guys aft to their turning blocks.
- Attach the sheets and guys to the clews and prepare to set the pole.
- Consider using a "pole guy" in addition to the regular afterguy if you are cruising.
- Place the afterguy through the beak of the spinnaker.
- Hoist the spinnaker to the masthead.
- Open the diaper, or if the sail is in stops, tug the clews to break the bands.

Setting an Asymmetrical Spinnaker

An asymmetrical spinnaker can be set on a spinnaker pole in the same way as a conventional spinnaker, making for a very efficient sail. It can also be set without a spinnaker pole, which is one of the benefits of this kind of sail since most cruising sailors do not want the bother of rigging up a spinnaker pole and its associated gear. Instead, you simply set the asymmetrical from a line at the bow, which is mounted either at the end of the bowsprit, if there is one, or on the deck. Lead the tack line aft to a winch where it can be adjusted once the sail is set, then lead the sheet aft as you would a symmetrical spinnaker and hoist the sail in a sock or stops. Note that when setting any kind of spinnaker it's often best to bear off slightly to get the sail into the lee of the mainsail so it won't be immediately

buffeted by the full force of the wind. By sailing further off the wind you can also decrease the strength of the apparent wind making the hoist easier still. Be careful, however, not to sail by the lee, since you do not want to risk having the spinnaker oscillate around to windward where it can get wrapped around your headstay. Once the sail is up you can steer back up to your original course. In fact, doing so fairly promptly is a good idea since your spinnaker needs to be out from behind the main if it is to fill.

Steps for setting the asymmetric spinnaker

- Set the asymmetrical from a line at the bow.
- Lead the tack line aft to a winch.
- Lead the sheet aft.
- Bear off slightly.
- Hoist the sail in a sock or stops.
- Pull the control lines to raise the sock, or break stops.

The Tacker

This book is not intended to endorse any particular sailmaker or product, but in the case of the Tacker, it's hard to describe what it does without using its trade name. Basically, the Tacker is a practical piece of equipment that is used to keep the tack of an asymmetrical spinnaker close to the headstay while at the same time getting it up above the deck where it will get plenty of clean air. Normally, because the spinnaker is set with a tack line, it falls off to leeward and the line chafes on the bow pulpit or lifelines. With the Tacker, a rigid piece of equipment that fits over a rolled up headsail, you can get the tack up as high as you want, keeping it under control with a single line. The bearing surface of the Tacker is sufficiently large that it does not chafe the sail, and once the tack of the spinnaker is attached you are able to keep the sail closer to centerline. This is obviously a more efficient way to set the sail.

The Tacker is a neat device that keeps the tack of an asymmetrical spinnaker close to the headstay.



Dousing the Spinnaker

Now that you have the sail set and all is right with the world, you need to consider how to get it down. There are a number of simple methods and we're going to look at the asymmetrical first because it's the easiest to douse. Bear in mind, however, that no matter what spinnaker you are flying, your mainsail is your best friend, since as was the case with the hoist, it can reduce the force of the wind on the sail when it comes time to douse. In fact, the lee it provides is invaluable. It's true that dousing a spinnaker on the race course means dragging the thing in no matter what angle of sail you are on. But when cruising you should do everything you can to make the takedown as easy as possible, and bearing away and blanketing the sail behind the main is a good place to start.

In either case, before you attempt to take the spinnaker down, think ahead to what needs to be done and what might potentially go wrong. For example, make sure there are no bits of gear in the way and that the tack line and sheet are neatly flaked, as is the halyard. After that, your goal is to collapse the spinnaker so

that you can either fire the tack and do a regular takedown under the boom, or douse the spinnaker by lowering the hoop on the dousing sock. To do the latter you should bear away gently until the apparent wind angle is around 150 degrees. At this point of sail the apparent wind speed will be at its lowest, and the spinnaker will be starting to collapse from the leech first in what is called a leeward break. Usually the spinnaker collapses when the luff folds over, but if you are successful in getting the sail into the dead air behind the mainsail the spinnaker will collapse from the other side. This is caused by the confused flow of air behind the mainsail sucking the leech in toward the sail. At this point your spinnaker is as tame as a puppy and you should be able to either lower the hoop down over the sail or let the tack line go and drop the sail to the deck. Never attempt to douse the spinnaker when the wind is on the beam unless the situation on the race course gives you no other alternative. In any event you will not be able to douse the sail with a sock until you have the wind sufficiently far aft.

Steps for dousing the spinnaker

- The tack line and sheet should be neatly flaked, as should the halyard.
- Bear away to reduce apparent wind and collapse the sail into a leeward break.
- Pull the hoop down over the sail or let the tack line go and drop the sail to the deck.
- Lower the sail to the deck.

Tips for Using a Dousing Sock

When using the control lines to lower the hoop over the sail, lead them through a ratchet block mounted on the rail at a point forward of the boom and to leeward since this will allow you a measure of control over the lines, and you will be pulling *up* from the turning block on the deck rather than down on the sock. This way your feet will be squarely on the deck and you will not be dangling at the end of the sock hoping that the sail does not accidentally fill and flip you over the lifelines.

If you are having problems dousing the spinnaker, the problem is likely that the sail has not collapsed properly. Rather than strain and struggle with the control lines, take a moment to look aloft and see what's happening. It may be that you need to bear away more or possibly ease the tack line so that the sail collapses.

Spinnaker Trip Mechanism for Easy Takedowns

There is an easy takedown system that the crew of *Alaska Eagle* developed during the 1981 Whitbread Race that served us very well, especially when the boat was sailing along on the edge of control. I have since used the system when cruising and introduced it to others. The consensus is that it takes away one element of concern when sailing with a spinnaker: that all-important element of releasing the sail to get it down.

In order to use this technique you will need a pole guy, and a spinnaker pole with a fairlead for a trip line that will be attached to the Sparcraft snap-shackle that

Setting up

- Run a trip line through the snap shackle and pad fairlead eye on the pole.
- Hoist the pole using the topping lift and pole guy.
- Set the spinnaker.

To drop the sail

- Ensure that the pole guy is fixed in place.
- Ease the afterguy.
- The pole guy holds the spinnaker pole in place.
- The trip line opens the snap shackle.
- Gather the sail under the boom.

secures the afterguy to the clew of the sail. (You may have to modify your existing pole.) Beyond that you need to run a trip line through the fairlead at the end of the spinnaker pole and loop it through the trip mechanism on the Sparcraft shackle, i.e., the one on the afterguy. When the spinnaker is flying the trip line just dangles in place waiting to be used (Figure 12.4). In order to drop the sail you need only ease the afterguy a few inches so that the clew of the sail goes forward pulling the trip line tight against the shackle while the spinnaker pole remains held in place by the pole guy. This sudden pressure on the snap-shackle will open the shackle and release the sail, so it can be lowered in a conventional manner. Note that the trip line must be a strong, low-stretch line like quarter-inch Spectra. Of course, if you need to jibe you will have to lower the sail and rig the system up on the other side. You also need to be careful that the trip line is loose so as not to accidentally trip the sail when you are moving the pole fore and aft as part of routine sail trim.

SPINNAKER TRIP-MECHANISM

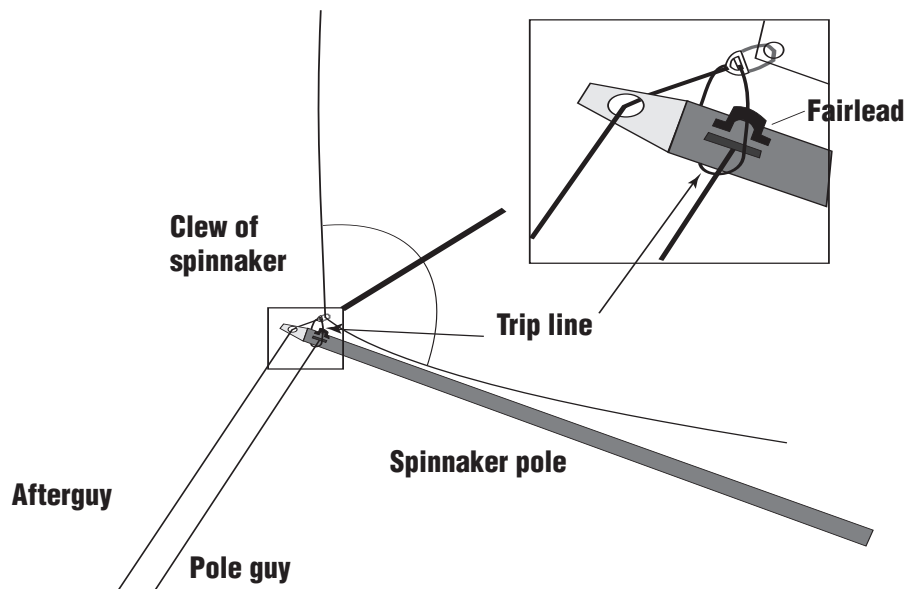

Figure 12.4

The spinnaker trip mechanism used on Alaska Eagle made getting the spinnaker down in a hurry a simple matter of easing the afterguy and having a trip line trigger the snap shackle.

Spinnaker Handling Techniques for Racers

As noted above, for the cruiser it is better to err on the safe and steady side when playing with spinnakers rather than take chances. But for racing sailors it's a different game. They expect to have occasional problems, and the trade-off between a quick spinnaker set and one that might possibly go wrong is a worthwhile risk.

In this section we will look at four maneuvers in detail:

- A bear-away set with a conventional symmetrical spinnaker.
- A jibe-set and a regular jibe with a symmetrical spinnaker.
- Jibing an asymmetrical spinnaker.
- Taking down the spinnaker.



These two photographs show boats approaching the windward mark with the spinnaker gear all set for a bear-away set.



Before we look at these techniques, there are a few points to consider:

- Always know the skill level of your crew and plan accordingly. It's no use waiting until the very last moment to drop the spinnaker at the leeward mark if your crew can't manage a quick takedown. You would do better to drop the sail early.
- Make sure that everyone knows his or her job. When sails are set or doused, especially when the wind is up, there is a lot that needs to happen and it all needs to happen very quickly.
- Make sure that there is a clear division of responsibility among everyone on board and stick to established routines for each maneuver.
- Keep calm. Yelling and screaming have no place on board a well-run boat.

With all of these spinnaker maneuvers it's important for all crews, even the experienced ones, to talk the maneuvers through before they carry them out. This reminds everyone of what's expected of him or her and refreshes the process in everyone's mind. With good planning, good communication, no yelling, and some practice, all of these seemingly complicated maneuvers can be carried out with ease.

The Bear-Away Set

A good bear-away set has two very important objectives:

- To make a smooth transition from sailing upwind to sailing downwind with as much speed and as little fuss as possible.
- To end up on the downwind leg with the spinnaker trimmed properly and the boat ready for an immediate jibe.

A clean rounding starts long before you actually get to the windward mark. The tactician, for example, will be keeping track of the wind shifts and know what phase the wind is likely to be in once you reach the mark, so he can call the set accordingly. In the case of a bear-away set, the foredeck hand can begin to set up the pole and its associated gear, and the spinnaker can be brought up on deck where it can be hooked up on the leeward side of the boat with the pole rigged to windward. Remember that it's important to get the gear in place with as little movement as possible, keeping the weight on the rail for as much of the time as feasible. Clip the sheets and guys to the clew of the sail. Hook the topping lift and downhaul to the spinnaker pole. Then hoist the inboard end of the pole to a pre-set mark on the mast. As soon as you are within a few boat lengths of the

Setting up

- Foredeck hand sets up the sail while still on the windward leg.
- Crew remains on the rail to keep the boat flat.
- Hoist inboard end of the pole to pre-set mark.
- Open the bag and hook up the sail.
- Start to sneak the windward clew to the end of the pole.

Rounding the mark

- Know in advance what the angles are going to be.
- Designated person calls the hoist.
- Square the pole and raise the sail at the same time.
- Ease the outhaul, release the backstay, situate crew weight for best advantage.

mark, open the spinnaker bag, drag out the clews and attach the halyard. You can begin to raise the outboard end of the spinnaker pole to a pre-set mark, and you can also start to sneak the windward clew up to the spinnaker pole. All this time it's important to be thinking about how best to lower the headsail. On many boats, especially those with masthead rigs, the spinnaker will not fill properly until the headsail has been lowered and is out of the way. Therefore, make sure that the halyard has been flaked and is ready to run and that the foredeck crew knows that the sail will be dropped as soon as the spinnaker is hoisted.

Again, as you round the mark it's important to keep as much weight on the rail as possible. This will help minimize the amount of rudder the helmsman will have to use to bear away; the less he has to turn the wheel, the better it is for keeping boat speed at a maximum. Somebody on board should be designated to call the hoist, preferably someone near the back of the boat who has a good overview of the situation, and the spinnaker should never be hoisted until that person gives the command. When the call comes be sure to square the pole and raise the sail at the same time. This will minimize any chance of the spinnaker being twisted. The sail trimmers should know in advance of getting to the mark the apparent wind angle of the next leg and be prepared to act accordingly. If, however, there is a tactical reason for sailing high or low, it should be communicated as soon as possible. The communication between the afterguard and trimmers must start long before getting to the turning mark.

Once the spinnaker is up and drawing, the crew can focus on other things like easing the outhaul, releasing backstay tension and getting crew weight in the right place – which is on the rail if it's a close reach with some wind, forward and to leeward if it's a light-air run or somewhere in-between. The crew should always be ready for an immediate jibe and have the lines clear and ready to run.

The Jibe-Set

Before we look at how to jibe, let's first go back to the windward mark and change the circumstances. This time the tactician wants a jibe-set rather than a bear-away set. This is a tactical maneuver that, if done well, can really work in your favor. There are a number of practical reasons to jibe-set at the windward mark, including the ability to protect a certain side of the race course or be first to an approaching puff. In any event it's an excellent tactical maneuver that is no more difficult to execute than a bear-away set. In many ways your approach to the mark will be the same no matter what maneuver you're planning, although in this case the foredeck hand will have the spinnaker bag on the windward side

“ . . . as you round the mark it's important to keep as much weight on the rail as possible. This will help minimize the amount of rudder the helmsman will have to use to bear away; the less he has to turn the wheel, the better it is for keeping boat speed at a maximum.”

This boat is approaching the windward mark set up for a jibe-set.



Bottom left: The spinnaker is hoisted before the mainsail and headsail are on the new jibe.

Bottom right: As soon as the headsail is across the spinnaker pole can be hoisted into place.



and the spinnaker pole ready to leeward. The big difference here is that, because you will be jibing at the mark, you cannot fully deploy the pole until after the jibe since it will get in the way of the sail. The inboard end can be raised, but not the outboard end. Make sure that the lines are clear and will remain so after the jibe. Pay special attention to how the genoa sheets are led.

As soon as you get to the mark and can jibe the boat, do so, and at the same time begin to hoist the spinnaker. As soon as the jib has crossed over, the pole can be raised, although you should focus on the spinnaker first and the pole second since on all but the biggest boats you can actually hoist and fly the spinnaker without it. On smaller boats you can even have one of your crew act as a human spinnaker pole, pushing the guy out with his hands while waiting for the real pole to be put in place. Until this is done, the helmsman should sail the boat under the spinnaker and as always he should be concentrating on boat speed and on making smooth, calculated turns. Sailing the boat under the spinnaker requires a skilled helmsman and can be as difficult as it sounds. It depends on the wind and waves, but basically running downwind the helmsman needs to keep the boat under the spinnaker and not let it get away on one side or the other. As soon as the jibe-set is completed, the crew should be ready again for another jibe.

Jibe-set

- Setting up is the same as for the bear-away set except the pole cannot be hoisted.
- Pay attention to how the genoa sheets are led.
- At the mark, jibe the boat and hoist the spinnaker.
- As soon as the jib has crossed over, the pole can be raised.
- Focus on the spinnaker first, the pole second.
- Prepare for an immediate jibe.

Perfecting the Jibe

Many sailors view this as the most difficult maneuver to accomplish under sail, and it probably is if the crew has not sailed together before. Practice, however, makes perfect, so you should get out there for a practice session and throw in as many jibes as your afternoon allows. For the purposes of this discussion let's look at three wind conditions you might find yourself sailing in – light wind, moderate wind, and strong wind – and see how the maneuver varies.

Light Winds

In many ways, the key to a successful jibe lies in the hands of the helmsman. He needs to keep the boat under the sail and turn the bow through the eye of the wind at the same rate as the sail trimmers are able to rotate the spinnaker without it collapsing. This is especially important in light winds when refilling a spinnaker after a collapse takes that much longer. You also need to be aware of turning so quickly that the spinnaker is blown into the foretriangle instead of floating around it.

Because you are (or should be) sailing at a higher wind angle in order to keep your boat speed up, you will have to bear away a lot more than you otherwise would in order to jibe. As you bear away you need to square the pole and rotate the spinnaker to windward, although do it gently and don't bring it so far back that the soon-to-be-new windward clew is up against the headstay. Keep the communication going between the helmsman and trimmers, and keep the bow under the spinnaker even after the pole has been tripped. Avoid coming up on course until the pole is in place and the sail trimmers are ready to make the changes. If you have executed a smooth jibe your momentum should carry you through the dead-downwind sailing until you are ready to come back onto a reach.

Light wind jibing

- Bear away gently and square the pole to rotate the spinnaker to windward.
- Keep the bow under the spinnaker even after tripping the pole.
- Resist coming up on course until the pole and trimmers are ready.

Moderate Winds

Jibing in moderate winds is the easiest. You will probably be sailing deeper wind angles and therefore squaring the pole prior to the jibe will not be necessary. Again, it's important for the helmsman to keep the boat under the sail and bring the bow through the eye of the wind at the same speed as the trimmers are able to rotate the sail. Make sure that the person calling for the spinnaker pole to be tripped can be heard as the wind increases, and avoid any unnecessary running about and talking while the jibe is in progress.

Heavy Winds

Many experienced crews will say that jibing in heavy winds is the easiest. There are some tricks to pulling it off, the most important being to do the jibe with the least amount of apparent wind. In other words, wait until the boat is on a surf and then bring the bow through the eye of the wind. The added speed from the jibe will make it easier for the helmsman to steer the boat, and because you will already be sailing very deep wind angles, the jibe angle will be relatively small. Compare a jibing angle of 40 degrees when the wind is up, to 120 degrees when the wind is light, and you will see why some sailors prefer jibing in stronger winds.

Heavy wind jibing

- Keep the bow of the boat under the spinnaker as you jibe.
- Wait until the boat is on a surf before jibing.

Jibing an Asymmetrical Spinnaker

This is not a difficult maneuver to perform, but like all sailhandling techniques it requires practice. Jibing an asymmetrical without a spinnaker pole is actually

quite easy. It's only when a spinnaker pole is employed that it becomes more difficult. Let's look at a pole-less jibe first.

Without a Spinnaker Pole

Just like jibing a symmetrical spinnaker, the helmsman plays a key role in the process. It's up to him to jibe the boat in concert with the speed at which the spinnaker is able to be moved from side to side. In light winds, the jibe must be gentle, keeping maximum boat speed and using a minimal amount of rudder to turn the boat. As the helmsman bears away, the spinnaker trimmer eases the sail until the boat is sailing dead downwind. At the same time, if possible, someone else tightens the tack line tensioning the luff of the sail. If it's not possible to do it simultaneously, tighten the tack line first and then ease the sail. The spinnaker will collapse from the luff first and curl in to leeward. At this point the sail can be rotated to the other side. If the sail is set on a bowsprit, the sheet can be passed between the headstay and the luff of the sail, but if the sail is set from the bow the sheet might have to be passed around the front of the sail since there will not be enough room to allow the sail to pass through. In either case it will now be on the new leeward side where it can be led aft and trimmed in. Again, the size of the boat, the aspect ratio of the spinnaker, and the distance between the headstay and luff of the sail will determine if the sheet is passed *between* the stay and the luff or *around* the front of the sail. Some smaller racing boats actually have two sheets attached, and the crew can jibe the sail inside the luff not unlike tacking a headsail.

With a Spinnaker Pole

It becomes a bit more complicated when a spinnaker pole is involved. The helmsman still plays a critical role, but it is up to the coordination of the fore-deck crew to execute a flawless jibe. As the boat bears away to begin the jibe, the load from the afterguy must be transferred onto the tack line by easing the

Jibing an asymmetrical spinnaker is easy especially if the boat has a bowsprit. The sail passes in front of the headstay.



former and simultaneously taking up on the latter. At this point the jibe is carried out as if there was no pole, moving the bow through the eye of the wind at the same speed as the sail passes to the new side. The foredeck crew, meanwhile, must release the afterguy, take the pole off the mast and bring it aft so that the outboard end can be passed behind the headstay and then re-attached to the mast with a new guy in place. As soon as everything is connected, the pole can be raised and pulled aft to match the new wind angle.

“There will be times when, despite your best efforts, it all goes wrong and the spinnaker ends up wrapped around the headstay . . . Quick and decisive action is therefore necessary.”

Without pole

- In light winds the jibe must be gentle.
- Tighten the tack line.
- Ease the spinnaker sheet.
- Rotate the sail to the other side.
- Pass the sheet between (on small boats or if there is plenty of room) or around (on larger boats) the headstay and the luff of the sail.
- Trim the sail in on the new jibe.

With pole

- Transfer the afterguy load to the tack line.
- Jibe the boat as if there was no pole.
- Release the afterguy.
- Bring the pole aft so that it can be set on the new jibe.
- Attach the pole to the new afterguy.
- Transfer the load back onto the guy.
- Rotate the pole aft.

What to Do When it All Goes Wrong

There will be times when, despite your best efforts, it all goes wrong and the spinnaker ends up wrapped around the headstay. Typically this happens when the sail opens early or it is allowed to wallow in the dead air behind the mainsail for too long. Often the second scenario happens right after the first. Let's look at the premature opening first. If the spinnaker is not banded properly or the stops break too soon, the spinnaker may open before it has been hoisted all the way to the masthead. In this case, you have two choices: either drop the sail and start over again, a good solution for a cruiser, or bear away to a dead run to reduce apparent wind and blanket the spinnaker behind the mainsail, and then hoist the spinnaker the rest of the way. If you choose the latter option you need to make a quick and decisive change of course making sure that the foredeck crew knows what's going on. If your effort is coordinated, a 10-second bear away is all you should need to get the sail hoisted the rest of the way. If you wait too long before bearing off, you stand the chance of the spinnaker oscillating and getting really out of control. If you linger too long with the spinnaker sucked into the lee of the mainsail you are in danger of it swinging inside the foretriangle and getting wrapped around the headstay.



The best thing for this crew to do would be to either drop the sail, run the tapes, and rehoist, or at least lower it so that a foredeck hand can grab the center seam and work his way up the seam as the sail is lowered until the wrap is out.

Should this happen you *may* be lucky and it *may* unravel itself, but I wouldn't count on it. Quick and decisive action is therefore necessary. Remain sailing downwind with the apparent wind at around 150 or 160 degrees. If you sail any lower the spinnaker will continue to oscillate and get even more wrapped. If you head up the increase in apparent wind will cause the wrap to get tighter, which will make it harder to sort out. If the helmsman sails the requisite course the foredeck crew needs to immediately start to lower the sail, with the first person that can reach the center of the foot of the sail working his way up the center-seam of the spinnaker gathering the sail as it's lowered. By continuing to work up the center of the spinnaker the sail will eventually unfurl itself.

What you do next is largely driven by the size of your boat. If you are on a small boat, immediately try to rehoist the sail. Then, as soon as the halyard is all the way up, the helmsman should turn the boat 10 to 15 degrees toward the wind to get the sail to fill so you don't end up with a wrap again. If you are on a large boat you may be able to carry this out but chances are you might do better to stuff the spinnaker below, bring up another one, and start all over again.

Spinnaker Takedown

Dropping the spinnaker at the leeward mark is a process that requires speed, skill, and a coordinated effort between the helmsman and the foredeck crew. There are a number of procedures to follow, and they apply to almost all kinds of takedowns. First and foremost, the jib must be raised. This not only provides a blanket for the spinnaker, it's also necessary for boat speed. Second, the spinnaker pole can be removed while the spinnaker is still flying. On small boats a "human" guy, as described earlier, can be employed to take the place of the pole; on larger boats the helmsman is going to have to sail skillfully and keep the boat under the spinnaker. If you are using both sheets and guys on the sail, fly the spinnaker on the



When a spinnaker is lowered it will trap a pocket of air under it so that it does not end up in the water, but allows the crew to gather it more easily.

sheets by taking up on the tweakers, i.e., separate lines led amidships and attached to the spinnaker sheets with a small block. Normally, they are used to fine tune the clew height as the wind angle changes, but by taking up on them as you remove the pole you will be able to get more control over the spinnaker since you will be flying the sail from amidships rather than from the back of the boat. Another advantage of sailing on sheets alone is that the winch that was being used by the guy can now be freed for the genoa sheet and readied for the hoist.

After that, assuming you are rounding marks to port, as is the case with most race courses, whenever possible drop the spinnaker on the port side of the boat: In other words, if you are coming in on port tack do a windward takedown as opposed to just dropping the chute on the leeward. This way you will already be prepared for another bear-away set at the top mark and you will not have to mess around with the sheets and guys pulling them over to the proper side of the boat when you are sailing the windward leg. If there is too much wind, or the boat is too large to execute this maneuver safely, you will have to do a more conventional leeward takedown and sort out the sheets and guys after you get around the mark. Otherwise, although many sailors don't do it, be sure to drop your spinnaker to windward whenever possible. Let's look at these two maneuvers separately.

The Windward Takedown

For the windward takedown to be successful there must be total coordination between all members of the crew, since it's a fairly difficult maneuver that requires precise timing. Again, hoist the jib early and remove the spinnaker pole and stow it. If possible heel the boat to windward so that the spinnaker will float to the windward side as well. As you arrive at the mark a couple of things need to happen at very nearly the same time. First, the spinnaker needs to be taken down to windward of the headsail, something that needs to happen very quickly. Because the headsail is in the way there is no fear of the spinnaker falling in the water and the man on the halyard should drop it as fast as he can. Next, the mainsail trimmer

must help the helmsman turn the boat by quickly trimming in the mainsail to bring the bow up into the wind. Note that it's important to get the mainsail in before the headsail, since this will force the back of the boat around, enabling you to steer the boat with the sails rather than the rudder. If you sheet in the headsail first it will keep the bow down and stop the boat from coming up into the wind. It's also important that as the foredeck crew begins to gather in the spinnaker it do so at the windward clew and not at the other end. Otherwise the sail will fill with air. After the chute is down and while the helmsman and main trimmer are approaching and then rounding the mark, clean up the lines so that you will be able to tack the boat as soon as you round the mark. Then as soon as you are around the mark, focus on heeling the boat to leeward if the wind is light, since this will enable the sails to set easier and to start generating speed sooner. If the wind is heavy, make a concerted effort to get all the crew onto the rail and hiking as soon as possible.

Windward takedown

- Raise the jib.
- Remove the spinnaker pole while the sail is still flying.
- Do a windward takedown if possible.

The Leeward Takedown

On bigger boats, especially in more wind, it's often advisable to drop the spinnaker to leeward since dragging the sail around to windward can be difficult or even impossible. If the boat is sailing at a broad wind angle with the spinnaker pole aft and the spinnaker rotated to windward, you can do this by undoing the shackle at the windward clew, or "spiking" the spinnaker, either by using a halyard and harness to send the foredeck man to the end of the spinnaker pole or by lowering the pole and easing the guy so that a crewmember can reach the clew of the sail from on deck. Another option is to simply let the guy run so that the sail collapses and can be gathered in behind the headsail.

If you are approaching the mark at a tight wind angle you can still spike the clew with a fid, or short, rigid piece of metal, but a better option is to do a float drop in which the halyard is released first to collapse the spinnaker, and the sail is sucked into the vacuum in the lee of the headsail where it floats down and

Leeward takedown

- Hoist the jib early.
- Remove the spinnaker pole.
- Heel the boat to windward.
- Drop the spinnaker quickly.
- Clean up the lines so the boat can tack.
- At the mark rounding trim the main in fast to help the helmsman turn the boat.
- Focus on crew weight.



This crew left it too late to lower the spinnaker and in their haste they dropped it in the water.



quickly is gathered in under the foot of the headsail. The problem with spiking the sail when you approach the mark at a close wind angle is that the spinnaker can sometimes get wrapped around the shrouds, or worse yet, float aft and get caught up in the mainsheet gear. Although it might seem reckless to just let go of the halyard, the sail will not end up in the water and the douse will work quite well. As was the case with the windward drop, the jib should have been hoisted before doing anything to the chute, and one of the crew should make sure that the halyard and guy are ready to run.

Spinnaker takedown approaching the mark at a broad wind angle

- Hoist the jib.
- Send man to end of the spinnaker pole to spike the afterguy.
- Alternatively ease the guy so it can be reached from the foredeck, or release the guy altogether.

Spinnaker takedown approaching the mark at a tight wind angle

- Hoist the jib.
- Do a float drop by releasing the halyard and gathering the sail under the foot of the headsail.

Handling Your Working Sails

While spinnakers provide the most fun (and inspire the most fear) when you are out sailing, your working sails can provide just as much challenge if they are not handled properly. Some sailors make it look easy when they throw in a reef or furl a jib, while others struggle and strain to get the same result. Technique is critical, and with that in mind we will look at some of the finer points of handling your rig on other points of sail.



Tacking

This may seem like a fairly simple maneuver, and in many ways it is. But there is a big difference between a good tack and a bad tack, with the former constituting a well-coordinated effort between the helmsman, the mainsail trimmer, and the two headsail trimmers while that latter is a haphazard maneuver that includes a lot of needless flapping of sails and loss of boat speed.

For example, in a good tack as the boat starts to head up into the wind the headsail trimmer should actually trim the headsail on a little bit more in an effort to eke out an extra bit of performance from the sail as the apparent wind increases and the apparent wind angle decreases. Same too with mainsail trimmer: As the boat comes around he should wind the sail on and bring the traveler up to windward. Both will help the helmsman use less rudder to turn the boat, while taking advantage of the increase in apparent wind and change in wind angle.

Once the bow has crossed the eye of the wind, the headsail needs to be let go, but not until it is back-winded for a second or two, since the pressure will both help push the bow of the boat onto the new tack and also push the sail through the foretriangle quicker. By this time, the headsail trimmer on the new side should already have taken up the slack on his sheet so that as soon as the sail is released he can start to pull it in on his side. Be sure, however, that the sail is not sheeted on too tight, too quickly, since that will cause the boat to stall. All this time, the mainsail trimmer will be working the main, sliding the traveler across and easing the sail so that when the boat is on the new tack the mainsail will not be over trimmed and stalled as the helmsman foots off ever so slightly to build speed. Remember that until the boat is back up to speed the apparent wind speed is going to be a lot less on the new tack than it was on the old one, so be sure that the main is twisted open and air is allowed to flow off the leech without interruption.

Once on the new tack be sure that both sails are powered up and slightly twisted open. You do not, under any circumstances, want to close out the leeches there-

“... in a good tack as the boat starts to head up into the wind the headsail trimmer should actually trim the headsail on a little bit more in an effort to eke out an extra bit of performance from the sail as the apparent wind increases and the apparent wind angle decreases.”

by stalling the sails. Your aim is to build speed, not gain lift. There should be constant communication with the helmsman as the boat speed picks up until the sails are fully trimmed back to where they were on the other side before the tack.

Tacking

- Communication between the helm and trimmers is critical.
- Trim the headsail and mainsail as the boat starts to luff.
- Bring the traveler up to help the helmsman use less rudder.
- Don't let the headsail go until there is a back-wind.
- Keep the sails powered up and slightly twisted to build speed.
- Slowly trim the last few inches as the helm comes up onto course.

Changing Headsails

Racing sailors will want to change headsails if the wind is increasing and they need a different size or weight sail to match the conditions. If this is carried out properly the amount of boat speed lost will be minimal. Screw it up, however, and you could find yourself at the back of the fleet. A “tack change” whereby the new sail is hoisted to windward of the old sail is usually the best way to do a headsail change since this allows the foredeck person to feed the luff of the sail into the headstay groove without much fuss and for the sail to be raised without falling in the water. The only drawback is that sometimes there is a bit of friction between the headsails. If you are sailing a large boat and it's a grind to get the new headsail raised, have the helmsman luff the sail a little. This lets a pocket of air get between the sails, and makes the job a lot easier. Once it is all the way up and there is sufficient tension on the luff, attach a new weather sheet on the sail and prepare to tack. The old genoa halyard will be flaked and ready to be released, and as soon as the bow of the boat passes through the eye of the wind, the old headsail halyard can be eased fully. The sail will drop to the deck, and if it is not all the way down by the time the tack is completed, it can be pulled down. The new headsail will stop the sail from falling into the water.

If a tack change is not possible you will just have to work with what you have, which will mean either more difficulty raising the headsail (if the new sail is set to leeward of the old sail) or more difficulty dropping the sail (if the old headsail is to leeward of the new headsail). When I raced the Whitbread Race on *Drum* we often encountered a problem when changing sails. The headsails were huge, and since a tack change was usually out of the question, we had to devise a system to make it easier. All the headsails were equipped with a cunningham ring two feet up the luff, so we would take up on the cunningham and release the tack before changing sails. This way the lower two feet of the sail would be free, allowing us to feed the new headsail under the old one and into the leeward groove. Furthermore, if we were trying to lower the leeward sail having a gap under the windward sail would allow us to get the old sail down under the new one. We

“If you are sailing a large boat and it's a grind to get the new headsail raised, have the helmsman luff the sail a little. This lets a pocket of air get between the sails, and makes the job a lot easier.”

would then reattach the tack on the old jib and set the new sail on the cunningham, so that we would have the lower two feet of the new sail free until the old sail was down. Then we would secure it at the tack.

Flaking a Headsail

Before a headsail is stuffed in its genoa turtle, you should be sure to flake the luff of the sail carefully on top of itself so that the next time you need to raise it the luff will feed out easily. A genoa turtle is used by racing sailors and is a long, sausage-like bag that can be either the same length as the foot of the headsail or one third the length of the foot of the sail. It's much easier to bag a headsail when it can first be done up in a turtle. You can then fold the turtle over on itself if you need the sail to be more compact. Before the turtle is closed, make sure that you use a sail tie around the luff of the headsail so that it remains neatly flaked.

Furling or Reefing a Headsail

This is not a particularly difficult maneuver to carry out, but when the wind is up and the spray flying, it can sometimes seem intimidating. In order to reef a headsail with a furling unit, you need to coordinate easing the headsail sheet with taking up the furling line. The first thing you need to do is give the headsail a big ease, which allows the sail to luff and gives you an opportunity to begin to reef the sail. If you ease it too much, however, the sail will flog wildly and both the leeward sheet and the windward sheet will start to wrap around themselves. Your best bet is to ease the sheet, take up on the furling line until it's tight, ease the sheet more, and so on. The same should apply to unreefing the sail. Once again, if the sail gets a chance to flog, the sheet may become entangled and you will end up with a problem.

Reefing a Mainsail

Slab reefing is not an especially difficult maneuver provided the different steps are carried out in order. Go about reefing the wrong way, however, and you may find yourself expending a lot of energy unnecessarily.

The first thing you need to do is be sure that the mainsail halyard is flaked and can be eased without getting caught on anything. Second, make sure that the boom vang is eased, since the boom needs to be able to rise up to the outboard end reef point when it comes time to take in on the outboard line. The actual reefing process begins by easing the mainsheet and halyard at the same time, ideally lowering the latter to a pre-marked position so you won't be left guessing with a squall staring over your shoulder. Mark the halyard at each reef location with waterproof marker, or even whip the halyard with a light line so you can feel the mark in the dark. If you have lowered the halyard to the correct mark, the inboard end will be at just the right position. If, on the other hand, you are lowering the sail down to a bull-

The crew on Drum struggle with the headsail during the Whitbread Round the World Race.





Reefing a mainsail on a large yacht can be a difficult experience especially when the weather is rough.

horn, snap shackle, or similar device, you will need to lower the halyard beyond your mark so that the person at the mast can secure the inboard end. As soon as it's secure, raise the halyard until there is sufficient tension on the luff of the sail. After that it's time to take up on the outboard reef, which is basically a matter of cranking in on the reefing line until the reef point is at the boom and the foot of the sail is tight. While you are doing this make sure there is plenty of slack in the mainsheet, otherwise you run the risk of seriously damaging your sail. If the reef is at the boom and the foot of the sail is still slack, you will need to change the position of the reefing line since the foot must be tight so that the sail has a flat

shape when it's reefed. Once the outboard end is snugged up tight, you can take up on the mainsheet and vang if necessary.

Unreefing a Mainsail

To unreef the sail, carry out the above maneuver in reverse. First ease the vang, then ease the outboard reefing line. After that, lower the halyard so that the inboard end can be freed, and then raise the halyard until the sail is fully hoisted. Once there is good luff tension, trim the main back on again and tighten the vang if necessary. Throughout this procedure, be sure that all lines are running free and that any sail ties you may have used to gather in the loose sailcloth have been removed. Trying to crank in the sail if it is caught at some point can result in serious damage.

Reefing a mainsail

- Flake the mainsail halyard neatly.
- Ease the boom vang.
- Ease the main halyard and the mainsheet at the same time.
- Lower the halyard to pre-marked position.
- Once the inboard end is secured, tighten the luff.
- Take up on the outboard end.
- Take up on the mainsheet and the vang.
- To unreef, do the above in reverse order.

All sail handling is a matter of technique and practice. The more you carry out the maneuvers and try out new ideas, the better you will be at sail handling. If it's unfamiliar territory to you, try these maneuvers out when the wind is light and the sea calm. Practice reefing and unreefing and changing headsails when there is no wind. Soon you will have the hang of it, and those huge sails will seem less intimidating. If for some reason you mess up and rip a sail, don't panic. In the next chapter we will learn how to repair those dings, rips, and chafed areas that are an all-to-familiar part of sailing.

Chapter 13

A STITCH IN TIME

Sail Care and Repair

A book that claims in its subtitle to be a comprehensive guide to everything about sails, is nothing about sails unless there is a chapter on how to repair them. Ultimately, a compromised sail inventory is not only bad for performance; it can affect the safety of both the boat and crew. Knowing how to care for your sails and repair them while you are at sea is a fundamental part of good seamanship. In fact, it's up there with knowing how to deploy and use storm sails. If you find yourself on a lee shore without an adequate inventory you might rue the day you turned down a lesson on basic sail repair. Note that while your local sailmaker will know how to do fancy repairs that blend into the rest of the sail, this chapter is more about how to effect a rudimentary repair while under way and how to take care of your sails on an ongoing basis. First let's look at basic sail care.

Sail Care

A number of factors contribute to sail wear and tear including excessive flogging and prolonged exposure to sunlight. The delicate yarns used in high-tech racing sails are especially vulnerable to these two forms of degradation. Other forms of wear and tear are all too familiar to many cruising sailors. Chafe, for example, is a big factor as is using the sail out of its engineered wind range. Finally, there is the issue of moisture and mildew.

Flogging

Modern fibers are very sensitive to being bent, and over time even the best sails will find a natural hinge around which to bend, which sooner or later will become a weak spot in the sail as the yarns break down and disintegrate. Letting sails flog is the principal contributor to this bending, and while it's impossible to prevent a sail from flogging on occasion, you should be aware of this problem and keep the flogging to a minimum. For example, when setting a mainsail many boat owners motor into the wind at speed while the sail flaps crazily back and forth, whereas it's only necessary to have sufficient speed to keep the bow pointed into the wind. By doing so, you can minimize flogging.

Walking on sails has a similar effect to flogging. Many sailors think nothing of stepping or sitting on bags of Kevlar sails, but the constant creasing ultimately damages the fabric. If possible, roll the sail when it's not being used and stow it out of the way. While it's natural to attempt to fold a headsail on its original crease, avoid doing so. The crease will only form a weak spot in the sail.

Sunlight

The other ingredient to a good day on the water (other than wind that causes flogging) is sunshine. Unfortunately, as stated earlier, many fibers are extremely UV sensitive and lose much of their strength from constant exposure to sunlight. All fabrics will eventually break down, some quicker than others, so making an attempt

“Ultimately, a compromised sail inventory is not only bad for performance; it can affect the safety of both the boat and crew.”

to keep sails covered when they are not being used will pay dividends down the road. In Chapter 2 we learned about fibers and the degree to which they are able to resist UV degradation. The following list, ranked from worst to best in their ability to resist UV degradation, are the fibers mentioned in Chapter 2:

Worst	—	PBO
		Technora
		Kevlar
		Vectran
		Nylon
		Pentex
		Dacron/Polyester
		Spectra/Dyneema
Best	—	Carbon fiber

Fortunately for cruisers, other than carbon (which is of no use because of its brittle nature) the fabrics most commonly used for cruising sails – Spectra, Dacron, Pentex, and nylon – are ranked relatively high. That’s not to say you shouldn’t take care of the sails. Indeed if you plan to spend a lot of time in the Tropics then you really need to take extra care when it comes to protecting your sails from the highly damaging effects of ultraviolet rays. This means keeping the sail cover on the main when it is not in use, and the headsails in their bags. Also consider adding strips of UV material to the leech and foot of your roller-furling sails if you have not already done so. You should remember, however, that even these covers lose their ability to protect the sail from the sun. Boom covers and sunshields get threadbare over time and as the fabric ages the sun will be able to penetrate through to the sail. For real bullet-proof protection you might consider having a mainsail cover built that has a foil liner on the inside. The foil liner is the same



Mainsail covers not only make a boat look neater, but they add life the sail, especially in hot climates where ultraviolet light can damage sails.



material that is used for making space blankets and it completely blocks the sun's harmful rays. An investment in a bullet-proof cover and UV-prohibiting films and adhesives when the sails are new will also help extend the life of the sail.

Chafe

This is something that occurs on all sailboats, although it's passagemakers and long-distance racers who are most sensitive to the problem because their sails are subject to long hours of continual use. Fortunately, you can do quite a bit about it. Racing sailors, for example, can install spreader patches to take the abrasion off the fabric as it is dragged over the spreader ends each time you tack. They can also install stanchion patches to compensate for the sail rubbing up against these pieces of hardware. Cruisers can not only take the same precautions, but take the process even further since they are usually less concerned about weight. For example, an additional chafe strip can be sewn along the foot of the sail where it clears the lifeline, and seams that rub against the mast and rigging each time you tack can be covered with a layer of sticky-back Dacron to protect them. Full-batten mainsails are particularly vulnerable to chafe where the hard surface of the batten comes into contact with the rigging or lazy jacks, so if you are planning on sailing downwind for a long period of time and the batten will be rubbing up against the rigging, have your sailmaker sew a length of webbing on either side of the batten pocket.

On a rig like the one on Drum, chafe patches were a must and can be clearly seen in this photo. In addition to having the patches someone was sent aloft daily to check for chafe and other kinds of wear and tear.

There is also a lot you can do on the boat and rigging itself to help minimize chafe. Take some time to go over the boat carefully in search of snags. Cover exposed cotter pins with tape and silicon, and where you can, cover rigging with leather. Cover the spreader ends with leather or tape them with sticky-back Dacron so that there are no sharp points to snag the sail. This extra effort will really help your sails last longer.

Using a Sail Beyond Its Designed Wind Range

When sailmakers engineer a sail they realize there are times when a sailor is going to be caught carrying too much canvas, so with this in mind they build in a significant margin of error. As a result, don't panic if you find yourself in a situation where the sails are overloaded, since it's likely that the sails, especially if they are new, will be able to withstand the extra load. This does not mean, however, that you can fly your sails in any conditions with impunity. Sailcloth has a certain yield from which it will recover, but continually pushing the sail to or beyond its yield point will only lead to problems, especially with sail shape. If you measure the life of a sail by how long it has a decent shape, rather than by how long it's a triangular piece of fabric, then you need to be sensitive to a sail's yield point and sail your boat accordingly.

Moisture and Mildew

It's inevitable that sails on a sailboat are going to get wet, so if you want your investment to last longer it's important for you to make an attempt to dry the sails when you are finished with them. A long-distance cruising sailor may laugh at the idea, and with fair reason. But racing sailors, weekend cruisers, and daysailers do have an opportunity at day's end to dry and stow their sails properly, and they should always be sure to do so.

If the sails are made from woven Dacron, for example, the salt particles in salt water will work their way into the fine yarns of the fabric. Later, when the water evaporates, they will become tiny salt crystals with razor-sharp edges. These sharp edges chafe at the fine fibers, snapping them one by one and slowly breaking down the fabric. The resin coating on new Dacron fabrics makes it difficult for the salt to penetrate, but over time this resin will break down allowing the diluted salt crystals to penetrate. Your best bet is to rinse the sails with fresh water and let them dry in a warm shady place.

Laminated sails, especially those with the film on the outside, are not as susceptible to salt as their Dacron counterparts, but it is still a good idea to rinse them off after they have been used since some fabrics are more prone to mildew than others. Bear in mind that usually it's not the fabric itself that attracts mildew, but rather the dirt and oils that collect on the surface of the sail. If you see a mildew spot it's best to treat it right away with a squirt from a cleaner like Tilex, which can be found on the shelves of most supermarkets.

Nylon is especially vulnerable to dampness, since when it is wet it loses as much as 15 to 20 percent of its strength. If you stash your spinnaker away still wet and then attempt to set it the next day in a stiff breeze, be careful. The sud-

“Nylon is especially vulnerable to dampness, since when it is wet it loses as much as 15 to 20 percent of its strength.”

den shock loading that occurs when the sail fills could cause it to explode. Your best bet is to wash your spinnakers with fresh water and then dry them on the lawn before using them again.

Another reason for washing sails to rid them of salt is the fact that salt eats away at hardware (like leechline cleats or blocks) mounted on the sail. Therefore, cleaning and drying your sails will not only prolong the longevity of the fabrics, but also that of the other pieces of equipment that are essential to making them work as well.

Sail Repair

As is so often the case in sailing, preparation is key, and carrying good sail repair equipment on board will allow you to fix most damaged sails. A sewing machine is nice, but not essential, and your decision about carrying one on board will be determined by the area where you are sailing and the types of repairs you want to be able to do. Basically there are two ways to approach each repair – a quick fix to help you make it to the next port, or a more elaborate job as good as any done by a sailmaker in a sail loft. If you are cruising remote islands, the chances of finding a sailmaker will be equally remote, and you should take a sewing machine on board and learn how to use it. If you are hopping up the East Coast of the United States, leave the machine behind and learn how to do quick patches so that you can make the next harbor safely since this region has lofts aplenty. Either way there are some basic techniques you should learn.

First, no matter what the job, you will need to do a quick damage assessment, a job that requires a flat wooden surface, sharp scissors, and a helping hand. If the rip is in a high-load area of the sail, you will fix it differently than if it is in a low-load area. The edges, for example, especially the leech and foot of the sail, will need quick and careful attention, while a rip in the middle of the sail can be slapped closed with a piece of sticky-back Dacron and left that way until you have time to do a proper job. For example, I once sailed over 300 miles with a hole in the middle of my spinnaker. It snagged on a shackle as I was hoisting it, but the rip was far from any load area, and there was no danger of the hole enlarging. I had run out of sail repair material so that's the way it stayed. If the rip had been near the luff or the corners, I would have been forced to drop the sail and not use it.

Sticky-Back Dacron

This simple product is one of the most important pieces of equipment on any boat, especially one heading offshore. Sticky-back Dacron is simply Dacron tape with an adhesive backing and is to the sailmaker what duct tape is to a boat builder: an indispensable item. It comes in various weights, but the three-ounce Dacron is the most versatile and also seems to have the best adhesion. You can build up to a required weight by layering the Dacron, doing so in a gradual transition so you will not end up with a “hard spot” at the edge of the patch that acts like a hinge and later becomes a weak spot in the sail. Before adding any sticky-back, make sure that the area to be patched is clean and dry.

“Sticky-back will adhere to damp Dacron, but the bond will be much better if the sail is clean and dry, and better still if you are able to heat the sail once patched.”

Wipe it clean with fresh water or better still with alcohol (not your best gin, but an industrial type). It is important that there is no grime or grease on the sail. Sticky-back will adhere to damp Dacron, but the bond will be much better if the sail is clean and dry, and better still if you are able to heat the sail once patched. Use a hair dryer or leave the sail in direct sunlight. The heat softens the adhesive and it bonds better. Use sticky-back for repairing all Dacron sails and for a quick fix on spinnakers, although it's not a good idea as a long-term repair on the latter since the Dacron is not compatible with nylon and will form a hard spot in the sail that could end up ripping after some time. You can use ripstop nylon tape for repairing spinnakers, although it does not have the adhesion of sticky-back Dacron and usually needs to be sewn down. Ripstop nylon tape is the same as sticky-back Dacron except that it's made from nylon fabric rather than Dacron.

You can also use sticky-back Dacron for repairing laminated and molded sails. In fact, it's especially effective when the outer layers of the fabric are film since it adheres extremely well. In general, with lighter fabrics sticky-back is probably best left unsewn since the needle holes only serve to weaken the base fabric.

Patching

The key to good sail patching is to lay the repaired area out flat and piece the edges together where you would want them to be when the sail is repaired. Use the underside of one of your wooden floorboards for a level surface and secure the fabric using your awls and pins. Trim off any frayed edges and pulled threads to allow the fabric to lay flat. Cut strips of sticky Dacron wide enough to cover the gap and carefully place them over the torn area. It's important to have the repair come out as smooth as possible since a hard spot will be a weak spot in the sail. Work from the center of the sail out toward the edges so that if your repair does not match up exactly, you can trim the excess fabric. If you work in toward the middle of the sail and find that there is excess you will have a problem. You can't simply cut off a chunk of fabric from the body of the sail.

On a Dacron sail decide how many layers of sticky-back you will need to build up to the sail fabric weight and layer them over your initial patch making each successive patch larger than the one before. Remember that the sticky-back weighs 3 ounces so divide the fabric weight by three to see how many layers you need. It's okay to go an ounce or two over, but don't overdo the patch. Again, you want to avoid a hard spot in the sail that could present a problem down the road. A 12-ounce patch on a 7-ounce sail is a problem waiting to happen.

Patch both sides of the sail. If you are repairing a rip in the middle of the sail and you are able to clean and dry the sail before patching it, you will not need to sew the patch. Simply lay an extra-large patch over the area and allow the adhesive to hold it all together "in sheer." As you near the leech, foot, or corners of the sail you will need to sew the patch since these are areas that experience higher loads. When doing so you might want to lay a piece of regular Dacron under the sticky to add strength to the repair, using the sticky to hold it in place. For a simple patch use a straight stitch – basically an up-and-under stitch that runs in a straight line – keeping each stitch no longer than a half-inch long and sewing

both sides of each row of stitches. Sew in one direction first and then sew back in the other direction using the same holes until each stitch has thread either side of it. If you are sewing through an area of heavy material, first bang holes in the fabric with a hammer and awl before sewing, then snap the sharp end off your needle and sand it to a blunt point. It will follow the awl hole with its blunt point and not try to make a new one of its own.

When using sticky-back Dacron for a quick repair on a nylon sail, apply extra-wide patches near the leeches and sew the leech tape back on with a sewing machine or by hand. Because the sail is too big for the small area on board, sketch the repair and come up with a plan before starting, once again working from the center of the sail out toward the edges. If you are planning on doing a proper repair, follow the same procedure for a temporary repair, and then turn the sail over and patch it properly with strips of nylon the same weight as the spinnaker. Cut the nylon and lay double-stick tape down the edges. Change the direction of the patch at each seam to match the thread direction of the fabric. Your temporary repair will hold the sail together allowing you to patch with nylon. Remove the backing on the double-stick tape, lay the fabric down smoothly and then sew the patches with your sewing machine. Once the nylon patches are sewn down, turn the sail over and cut away the temporary sticky-back Dacron patch with scissors. Cut along the edge of the stitching on the permanent patch, and remove the fabric and sticky-Dacron. Finally sew a row of stitching down the seam and across the new patch to hold it all together and aid the transition of the patch into the sail.

If a corner ring pulls out, you can replace it with one of your spare rings. Eyeball where the ring should be positioned, and lay strips of 2-inch nylon webbing through the rings and onto the sail. Use double-stick tape to hold the webbing in place, stagger the ends of the webbing so that their transition into the sail

Repairing downwind sails

- Do a damage assessment.
- Clean the torn area with fresh water or alcohol.
- Lay the sail on a smooth surface and piece the edges together.
- Trim the frayed edges.
- Patch with sticky Dacron (temporary) or nylon strips (permanent).
- Remove the temporary patch if doing a permanent patch.

Repairing working sails

- Do a damage assessment.
- Clean the torn area with fresh water or alcohol.
- Lay the sail on a smooth surface and piece the edges together.
- Trim the frayed edges.
- Patch with sticky Dacron building up the layer to the required strength.
- Sew the patch to the sail (especially if in high-load area).

Sail Repair at Sea

My second Whitbread Race was aboard Drum, the British yacht owned and sailed by Simon le Bon, the lead singer of the rock group “Duran Duran.” The sails on Drum were huge. It was in the days when the Whitbread was raced under the old IOR rule, and we raced with more than 20 bags of sails on board. The headsails were masthead and made from Kevlar. They were massive and very difficult to repair. We had to lash them as tightly as we could and hammer the fabric through the sewing machine in order to carry out even the smallest repair. The spinnakers were 5,000 square feet, and when they blew out they came down to me, the sailmaker, in a dozen bits of wet nylon. I had a 4-by-4-foot piece of upturned floorboard as my repair loft. To repair the spinnakers I had to first dry the torn edges with a hair dryer. Then I trimmed the frayed bits before trying to figure out where each piece went. Fortunately I was good at jigsaw puzzles and always managed to get the sail back together.

Being a sailmaker on a Whitbread boat requires innovation. Often we would not even take the bigger sails down, but instead I would go aloft with a helper to repair the sail. We would use layers of sticky-back Dacron to repair the rip, and then with myself on one side of the sail in a bo’sun’s chair and my assistant on the other, we would push a needle and thread back and forth until we had the sail stitched together. We used the same technique four years later when I sailed on Fazisi with the Soviets. At times it seemed like an extreme measure. Why not simply lower the sail and repair it on deck? By that time the racing had become so competitive that there was no longer room for compromise. When we finished the first leg of the Whitbread in 1989, for example, we came in sixth place. The seventh-place boat was two-and-a-half minutes behind us, the eighth-place boat was nine minutes behind, the ninth-place boat was nineteen minutes behind, and we could see the tenth-place boat in the distance. Dropping a sail to repair it might have made the difference between a sixth- and a tenth-place finish.

is gradual and then secure the entire repair together with a layer of sticky Dacron since it will be easier to sew the webbing if everything is held in securely in place. Follow the same procedure of banging holes in the webbing with an awl and then sewing it with blunt needles. Put in a few rows of zigzag stitch, being careful to pull each stitch as tight as you can.

If you run out of sticky-back Dacron and double-stick tape, spray adhesives work quite well to hold the fabric in place. So does a glue gun, although you will have to sew the patches down since the spray glue and hot glue do not have a strong enough bond.

There is nothing difficult about repairing your own sails. Like most everything in sailing, a little common sense goes a long way. Good preparation, a little patience, and a good sail repair kit are all that you need. Here then is what a good sail repair kit will contain.

Sail Repair Kit

Your onboard sail repair kit will be as comprehensive and varied as the passage you are planning and should be tailored to suit your needs. Store the bulk of the items in a bag in a dry, convenient place, and have a smaller bag containing items that you need more often in a more accessible place. The smaller bag should include:

- scissors
- wax thread
- needles
- whipping twine
- some sticky-back Dacron

Keep the needles in a tight container wrapped in a cloth that has been lightly soaked in sewing machine oil. Also wrap your scissors in an oiled cloth, since even though they are stainless steel they will rust if not protected. Roll the pieces of nylon, sticky-back Dacron and regular Dacron tightly, and hang them in a waterproof chart storage tube from the overhead in your forepeak.

A basic sail repair kit will include the following items. Amounts will vary depending on the size of your boat and the trip you are planning. The amounts noted here would be suitable for a 40-foot yacht planning a transatlantic passage.

- 1 pair stainless steel scissors
- 1 pair regular scissors as backup
- 1 knife dedicated to sail repair
- 6 awls to secure the sail while patching
- 2 dozen push-pins with plastic heads to secure the sail while patching
- 1 adjustable hand palm for hand sewing sails
- 3 seam rippers
- 1 roll of pre-waxed hand sewing thread
- 1 roll of sticky-back Dacron tape 5 inches wide
- 10 feet of sticky-back Dacron 54 inches wide
- 5 rolls of double-stick tape
- 2 cans of spray adhesive
- ¾-inch tubular nylon webbing
- 2-inch nylon webbing
- 2 stainless steel rings with bar
- 10 feet of Velcro
- a selection of needles, size No.14 and 15
- staple gun and staples
- lump of wax
- assorted pieces of Dacron and nylon

A more comprehensive kit would also include:

- a spare set of battens
- spare hanks

“ . . . when I sailed on Fazisi with the Soviets . . . Dropping a sail to repair it might have made the difference between a sixth- and a tenth-place finish.”

- a spare luff tape the length of your longest headsail
- leechline cord twice the length of your mast height
- an entire corner patch of one of your spinnakers
- hot knife
- Nicropress tool and sleeves
- Hole cutter and assorted rings
- 20 feet of seizing wire

Determine the Condition of Your Sails

The end of the sailing season is a natural time for you to take stock of your sail inventory and go over each sail to evaluate its condition. You can ask your sailmaker to do the checking, but it's not rocket science and you can save yourself some money if you do it yourself. All you need is a dry lawn and some time on your hands. This might also be a good time to give the sails a final rinse in fresh water before stowing them for the season.

Check Fabric

It's fairly easy to gauge the integrity of your fabric, especially a woven Dacron. Take a blunt edge like the back of a knife and rub the surface of the sail. If it comes up shiny and smooth where you rubbed then you know that the fabric is still in reasonably good shape. If, on the other hand, the fibers start to get fuzzy then you know that there has been some UV degradation and you need to be concerned. In some cases you might be able to rub a hole in the fabric in which case the sail will have to be replaced. If your sail has ripped during the season, take note of how it ripped because it will give you some clues as to the condition of the fabric. Smaller yarns degrade and break quicker than the larger yarns and in most cross-cut sails the small yarns are found in the warp, especially if the fabric is fill-orientated. If the sail developed a rip parallel to the leech, in other words across the warp, then you can be sure that some degradation has occurred to the smaller warp yarns. The same amount of degradation will have occurred to the fill yarns, only it will take longer for it to show.

Check Seams

Seams are the most vulnerable areas of sails and a thorough check of each one may save you a costly blow-out down the road. If your sailmaker used colored thread it will make your job a lot easier. If not, examine each seam for loose or broken stitches, and mark each place with a piece of colored sticky Dacron. Hold the sail up to the light and determine whether you can see daylight through the stitch holes. If you can, it's a sign of impending trouble, since it means the seams have been overloaded and are vulnerable to blowing apart. Pay particular attention to the areas around the corner reinforcement patches. If the last row of stitches show sunlight through the stitch holes, it may mean that the corner patches are not large enough or strong enough for the sail, or that you have overloaded the sail on more than one occasion. Have your sailmaker either re-sew the seam or possibly extend the reinforcement patch.



The mainsail on Pindar has been patched at the third reef. The skipper Emma Richards did the repair by hand on deck in the Southern Ocean.

Check Hardware

It's important to take a close look at the sail attachment hardware like batten cars, luff slides, and hanks to see if there is any wear and tear or hairline cracks. The cars on the inboard ends of battens are often under a compression load, while the intermediate slides are under tension. Look for wear, paying particular attention to the slides at the head of the sail and above each reef, since these are the ones most heavily loaded. Check the webbing and stitching that hold the hardware to the sail to be sure that it is still strong.

Hanks generally do not fail, but it's worth checking each piston if it's a piston-hank, or spring if it's a Wichard-type hank to see if it works properly. Sometimes a halyard gets in behind the piston or spring and bends it so that it does not close easily, or worse yet, it does not close at all. If there are hank reinforcement patches on the sail check them for chafe; if not, check the sail to see if there has been some noticeable point loading on the fabric.

Also take a close look at the leechline cleats and other hardware that is bolted to the sail. If the sail has been put away wet, these small aluminium pieces are the first to feel the effects of corrosion.

“These days with modern materials, sophisticated computer programs for determining loads, and judicious engineering, a sail should never blow out unless some other factor has come into play.”

Look for Chafe

It’s important to check the sail over for chafe even if you have chafe protection spreader patches or the like. By the end of a season the light Dacron chafe protection could have worn through and will need to be replaced. Batten pockets are always vulnerable to chafe and should receive extra attention. The same applies to the edges of the sail like the bolt rope along the luff of a mainsail or the foot of a genoa where it passes over the lifelines. Make notes and mark the sail with a piece of colored sticky Dacron where it needs attention.

Replace UV Protection

The sunshield on cruising headsails is good for a number of years depending on where you sail, but it’s not good for life and so you should replace them every few years. This is especially true if you live and sail in the Tropics. Remember that the acrylic fabric is being exposed to the blazing sun all day every day whether or not the sail is being used.

Maintaining Your Investment

Sails are a big investment, not only in terms of hard-earned money, but also in time and energy. It’s important that they be taken care of and thoroughly examined on a regular basis. There is nothing quite so disheartening as a sail blowing out, and blown sails are almost 100-percent avoidable. These days with modern materials, sophisticated computer programs for determining loads, and judicious engineering, a sail should never blow out unless some other factor has come into play. Chafed seams or a small rip caused by a sharp edge usually form a weak spot in the sail. It’s important to overall seamanship to take care of your sails, so be kind and cautious and you should never have a problem with ripped sails.

Chapter 14

MORE QUESTIONS THAN ANSWERS

A Conversation With Your Sailmaker

This book started out with a hypothetical visit to a sailmaker. It was a way to get you thinking about sails and the sailmaking business, and to start you thinking about the kind of sails you might want for your boat. As I pointed out, the process starts by asking a lot good questions, both of yourself and your sailmaker. I also noted early on that there are many different ways to make the same sail and that all of them will probably result in an excellent product. The business of sailmaking has become complicated, but if you remember this point you should be confident that you will end up with great sails for your boat.

The body of the book covered a lot of ground. Now it's time to review some of the information we covered through a series of questions and answers. Each question has a short, to-the-point answer with a reference where you can find more information on the topic within the pages of the book. Remember that there will always be more questions than answers because there are so many variables. A salty old cruiser with a gaff-rigged double-ender heading across the Atlantic will have different needs from a beginner sailor heading the same way in his new Little Harbor 52. You, the reader, need a broad understanding of the topic and then apply what you have learned to your own specific circumstances. With that in mind, here are some questions and answers.

Is polyester only used to make cross-cut sails?

No. Polyester, or Dacron as it's more commonly known, is woven to make fabric and this fabric, which comes in varying weights and finishes, is then used to make cross-cut sails. Polyester can also be laminated as a scrim and used to make radial sails.

Is there a limit to the size of boat that can have Dacron sails?

There are some practical considerations that make it foolish to have Dacron sails beyond a point. On very large boats – above 100 feet – the amount of Dacron necessary to manage the loads would make the sails very heavy and difficult to handle. So much Dacron would be necessary that at some point it would actually be cheaper to use something more exotic like Pentex or Vectran.

Nylon has some give to it. Is that good for spinnakers?

Yes, especially for spinnakers that will be used for broad reaching or running where strength for weight is more important than stretch resistance. For spinnakers that will be used on a close reach, a more stable nylon or a light laminate might be a better choice because the sail needs to retain its shape to perform properly.

Pentex is also a polyester: How is it that Pentex sails perform better than regular Dacron?

Pentex is a modified polyester that combines all the great qualities of Dacron without the one major drawback – stretch. Once the fibers have been modified they lose some of their ability to shrink when they are heat-set, so Pentex is not woven, but rather used as a scrim in a laminate. The combination of the fabric being a laminate and used for radial construction results in sails that perform a lot better than those made from regular woven Dacron used in a cross-cut configuration.

What are the attributes and drawbacks of Spectra?

Spectra has very low initial stretch, but over time under a constant load, it starts to creep, or elongate. This is not good for high-performance racing sails, but Spectra's other qualities like good UV resistance and terrific flex make it a perfect fabric for performance cruising sails, especially on large boats. Unfortunately, when there is unrest in the world the price of Spectra goes sky-high because it is also used in great quantities by the defense industry.

Why would you not use Kevlar for cruising sails?

You can use Kevlar for cruising sails, but you have to be very careful how you engineer the fabric. Kevlar loses its strength when flexed by flogging or exposed to sunlight. If you are able to engineer a fabric where the delicate Kevlar yarns are sandwiched between UV-coated taffetas and the yarns run along load lines and not at right angles to the way a sail flaps in the wind, i.e., across the sail, you can build a Kevlar sail that will last a long time. It's more suitable for really large boats where you need a more complex laminate and Kevlar is only one of a number of yarns utilized.

What about Vectran? Where does this fiber fit in?

Vectran is growing in popularity for a number of reasons. It is incredibly strong and does not lose strength when it is flexed. Unfortunately, like Kevlar, it's extremely UV sensitive and so the fabric needs to be carefully engineered to protect the yarns from the harmful rays of the sun.

Is there a future for PBO in sailmaking?

Possibly. Weight-for-weight, PBO has better strength and stretch characteristics than any other currently available fiber, but what it gains in strength and stretch resistance, it loses immediately if exposed to any kind of light, not only sunlight. If sailmakers have an application where you need the positive attributes of PBO and can, through clever engineering, minimize the negatives, it might be useful; however for now the fiber is so expensive and there are so many other better choices available that PBO is losing popularity.

And carbon. Does it have a future?

Most certainly. You will be seeing a lot more carbon in sails, especially at the top end. For now it's usually used as part of a blend with other fibers picking up where carbon is weak, namely in flex. Different types of carbon are being

developed that have better flex properties, but in order to gain better flex they lose in areas like stretch resistance. It's a balancing act, but the fiber is so terrific that fabric makers and sailmakers are working on ways to incorporate it into their sails.

Can woven fabrics be laminated?

Certainly. While one of the advantages of laminated fabric is that the load-bearing yarns can be applied as a scrim, i.e., loose grid of fibers, you can still laminate a woven substrate to a film. These fabrics are very good if you are looking for rugged durability like a Spectra for an Around Alone race or for a large offshore cruiser where you need a high yarn count to handle the loads. It's fairly difficult to engineer these fabrics if Spectra is going to be the principal yarn because Spectra is a slippery fiber that does not adhere very well, and it's better if there are gaps between the fibers, as in a scrim, so that the adhesive can bond between the fibers. On the other hand, some fabric engineers have developed adhesives that will bond to Spectra without delaminating.

What are the differences between fill-orientated fabrics, warp-orientated fabrics, and balanced fabrics?

Fabric engineers can vary the sizes of the yarns running either along the length of the fabric, i.e., the warp, or across the fabric, i.e., the fill, so that a woven material can have more or less strength in a certain direction. For example, a sailmaker might want a fabric that has a lot of strength in the fill direction so that he can build a blade jib that has the loads running pretty much up the leech of the sail, i.e., in the direction of the fill. For a low-aspect sail like a No. 1 genoa where the loads are fairly evenly distributed throughout the sail, he could ask the fabric maker for a balanced fabric, one that has similar yarns running in both the warp and fill directions.

What does heat setting do to a woven polyester fabric?

The aim with all woven fabrics is to get a tight weave so that the fabric does not stretch, especially on the diagonal, or the "bias." Fabric makers use various techniques to create a tight weave and one of the best ways is to pass the fabric through an oven or over heated rollers. This causes the yarns to shrink by as much as 15 to 20 percent, which dramatically tightens the weave.

What are the drawbacks of fillers in woven polyester fabrics?

Dipping the fabric in a bath of melamine resin coats the fabric, allowing the resin to penetrate the gaps between the fibers and stabilize the fabric, increasing its resistance to bias stretch. The problem is that over time the resin starts to break down, and the crystals that once gave the fabric terrific stability are no longer there. Without the resin, the fabric is more susceptible to stretching. This is why fabric makers rely more on a tight weave than on fillers. Note that a stiff, resinated fabric is easier for the sailmaker to work with, but it's tough on the hands when handling the sail. Like most things in sailing, adding resin needs to be balanced against many other factors.

What does the calender do?

Calenders are giant heated rollers that apply tremendous pressure on the fabric, as much as 150 tons, and some fabrics are passed through the calender a number of times until the fabric takes on a high sheen. At this point the woven Dacron fabric is as nonporous and low-stretch as it's ever going to be.

What are some of the things to look for in a good Dacron?

Yarn quality is important. Ask your sailmaker what type of yarn will be used for the fabric. Remember that Type 52 Dacron is the highest tenacity fabric and offers a premium balance of high strength, low stretch, and maximum shrinkage when compared to other Dacron types. You should also look at the tightness of the weave, note whether the fabric is fill orientated, balanced, or warp orientated, and know how this point relates to the sail you are buying. Other than that, ask your sailmaker about tear resistance, abrasion resistance, and whether the fabric has some UV protection. Remember to compare apples to apples when comparing the price of sails. One of the biggest discrepancies will be fabric choice.

On a laminated fabric, what do the taffetas do?

The taffetas can add abrasion resistance, and if they have been UV treated they can protect the light-sensitive load-bearing yarns in the laminate. For example, if the principal fiber is Vectran, sandwiching the Vectran yarns between two UV-treated taffetas will extend the life of a fabric appreciably. They add weight to a sail, but they also add durability, and for offshore sailors taffetas are well worth considering.

How does Cuben Fiber differ from ordinary laminated fabrics?

Cuben Fiber is a much more complex means of creating fabric. For a start, it is made of many layers of untwisted filaments laid in a multitude of directions. Once the fabric has been engineered, it is loaded into an autoclave and baked under high heat and pressure until the individual filaments and film become one, making it extremely strong and stretch resistant for its weight.

Can I have Cuben Fiber sails for my boat?

If you are willing to pay the price you certainly can. The process of making the fabric is labor intensive and therefore the cost of the raw fabric is expensive. Once you get into the heavier weights of fabric and boats with much higher loads, the price difference between numerous layers of, say, Spectra and Cuben Fiber becomes less a factor and Cuben Fiber becomes more of an option.

Can you explain why sailmakers started to ply sails?

Cross-cut sails have the same weight of fabric running across the sail even though the loads vary from one end of the sail to the other. The loads up the leech, for example, are much greater than loads up the luff. Before the advent of radial sails, the only way sailmakers could save weight and engineer more efficient sails was to build a sail with a lighter base fabric and then add a second ply in the high-load areas. For example, they would use a balanced Dacron for the body of

a mainsail and add a ply of fill-orientated Dacron up the leech to take the increased loads in that area. They would use a number of different techniques to transition the two-ply area into the single-ply area, such as cutting the second ply in a crescent or a saw-tooth pattern.

What are the advantages of radial sails?

Unlike cross-cut sails where the same weight fabric along the luff is used along the leech, a radial sail can have a lighter weight at the luff and a heavy fabric in the high-load area such as the leech. The fabric used for radial sails is also engineered so that the strength runs along load lines, i.e., out of the corners and up the leech. It's a much more efficient way of engineering sails.

What are the disadvantages of radial sails?

The only real disadvantage is that the sails cost more to make than cross-cut sails. The fabric used for building radial sails is more expensive to manufacture, and radial sails are more labor intensive to build, both resulting in the cost of the sail being increased.

When would one consider a bi-radial mainsail?

If a mainsail is used principally for sailing upwind and downwind, as with most inshore race courses, there is not much need for a tri-radial sail. The loads sailing upwind travel right up the leech of the sail; there is very little or no load up the luff or radiating out of the tack. With no load coming out of the tack you do not need panels radiating from the tack to pick up those loads. The same applies when sailing downwind. The overall load in a sailplan is reduced when sailing downwind so that there is no need for tack gores.

When would you need a tri-radial headsail?

Boats that will be sailing on a reach need gores radiating out the tack to take the loads that emanate out of that area when a boat is sailing at that angle of sail. Cruisers who spend time beam reaching in the Trades will do well to have a tri-radial mainsail.

Can you define what you mean by a molded sail?

Molded sails are sails that are created in whole sections over a curved mold rather than pieced together from panels of flat sailcloth as is the case with cross-cut or radial sails. Molded sails are a kind of laminated sail in that they are made up of layers of fibers, taffetas, films, and adhesive that are stuck together. But they are different from laminated radial sails in that they are not built from pre-made bolts of cloth. Instead, the "cloth" is actually created on the mold as the sail is manufactured.

Can you define the difference between a filament and a fiber or yarn?

Fibers are bundles of filaments twisted together to create a yarn. Molded sails like 3DL or Genesis are created from fibers. Cuben Fiber sails are created from filaments.

Are molded sails as durable as paneled sails?

In some cases they are more durable. If a 3DL or D4 sail, for example, has taffetas on either side of the sail, it will be more durable than a regular paneled sail without taffetas.

Define chord depth and explain how it relates to sail design.

The chord depth is determined by running an imaginary line from the luff of a sail to the leech, and then measuring the distance from this line to the deepest part of the sail. It is usually expressed as a percentage. Higher percentages, i.e., sails with a deep chord, are used for light winds to generate power in the sail. Lower percentages, i.e., sails with a shallow chord, are used in stronger winds. If you use a deep sail in strong winds, the wind becomes separated on the leeward side of the sail as it attempts to make the sharp turn at the deepest part of the sail and finds that it is flowing too fast and becomes detached. The result is that the lift is lost and the boat's windward performance suffers.

Why is there twist built into sails?

The surface of the water presents an area of friction that slows the speed of the air molecules closest to it leaving those particles higher off the water traveling at a faster rate. Because the wind up high is moving faster it draws the apparent wind angle aft and closer to the direction of the true wind. Since the wind aloft is further aft than the wind down low, you need to design a sail to compensate for these different wind angles. That compensation comes in the form of twist.

Please explain induced drag.

Wind flowing across a sail will try to escape over the top of the sail and under the bottom of the sail as it tries to get from an area of high pressure to an area of low pressure. As it does so, it creates small vortices that rob energy from the wind flow and disturbs the wind pattern flowing across the sail. These performance-robbing vortices are induced drag.

What can be done to minimize induced drag?

Keeping the lower sections of a sail flatter than the body of the sail effectively funnels wind across the sail rather than allowing it to escape under the sail. It's more important to have flat sections at the bottom of the sail where there is a long chord rather than at the top where the sail comes to a narrow point. You can also have the sail sweep the deck if it's a headsail, since by being right up against the deck the wind can't escape under the foot of the sail. But this is not possible for mainsails so the flatter chords down low are therefore more important for mainsails.

How important is the luff curve?

It's very important for the design of the sail to match the curve of whatever it is being placed up against. For example, if there is six inches of bend in the mast and the sail designer wants to use luff curve as a way to add shape to the sail, the luff curve must be more than 6 inches since those first 6 inches will be doing nothing more than compensating for mast bend. If, for example, he puts in 8 inches of luff curve, then 2 inches of that curve will be fed into the body of the sail as shape. It's

the same with headsails, although the curve is concave rather than convex. If the sail design does not take into account the sag in the headstay and assumes it's going to be straight, the extra fabric along the luff will be fed into the body of the sail as unwanted shape.

Can you describe the difference between molded shape and flying shape?

Molded shape is the shape of the sail before any loads or stresses come on it. Once the sail is put into use it will stretch and the shape will move around. This is the flying shape. Sail designers need to understand these loads and compensate for them in the design so that when the sail is actually flying, the sail assumes its desired shape.

Can you explain how shape is added to flat panels of fabric?

Just as a beach ball is made up of numerous flat panels with curved edges placed against each other, shape can be added to a sail in a similar manner. Of course, the amount of shaping is far less than for a beach ball, but by curving the lower edge of a panel of fabric and placing it against the straight edge of the panel below it, the sail starts to develop shape. The amount of curve determines the depth of the sail.

Why does the weight of sails matter?

There are a number of reasons. One is that light sails are much easier to handle and take up less room when stowed. Furthermore, even on boats where sail handling is minimal, like those with furling units for the headsails and in-mast furling units for the mainsail, the amount of weight aloft is important since heavy sails add to the heeling and pitching moment and can fatigue the crew. Light sails are also easier to set and trim.

How do I know how many reefs I need?

It depends on your boat and the type of sailing you plan to do. If you have a boat that heels over easily you might need more reefs. If you are heading offshore you definitely need more reefs. For coastal passages you can get away with two rows of reefs. For transoceanic passages you should definitely go with three rows of reefs.

Can you explain the pros and cons of full-length battens.

Full-length battens add to the life of a sail by supporting the fabric and reducing the amount a sail flogs. They also allow the sail to hold its shape well in light winds and choppy seas, and make it easier to handle the sail with lazy jacks. On the other hand they add to the weight and cost of a sail.

What are the drawbacks of in-mast furling systems?

The systems are fine. It's just that the sails you use on an in-mast furling system are compromised because you can't roll battens into a mast unless they are vertical, i.e., parallel to the mast. Standard rollaway mainsails have no roach, and because of this fact they lack sail area and do not generate as much lift as a conventional sail.

What can be done to improve the performance of an in-mast furling mainsail?

As mentioned above, vertical battens can be added to the sail to support a moderate amount of roach. Swing battens, i.e., battens that swing into a vertical position when the sail is being rolled away, can also add a moderate amount of roach. Neither of these systems add as much roach as can be found on a mainsail that has conventional battens, but they do go a long way toward increasing the performance of the sail.

What does a foam luff pad on the luff of a headsail do?

The luff pad is made from quarter-inch closed-cell foam and is tapered toward the head and tack of the sail. When you take a turn on the furling unit, the luff pad bulks up around the headstay, and this bulk effectively removes shape from the sail with each successive turn.

Do I need a sunshield?

If you keep your boat in a tropical climate it's a very good idea to have a sunshield, since it will protect the sail when it is rolled up. If you live in an area where there is not a lot of sun, the sunshield is not that important, but it's still nice to have because it helps protect the sail and keeps the leech clean. You can have your sailmaker replace the sunshield when it gets dirty.

How important is clew height?

On racing boats it's good to have a low clew. Keeping it low provides the best upwind performance since the sail has a more consistent shape, the center of effort is lower, and you will have a short, sure sheeting point. For cruisers, especially those heading offshore, raising the clew makes sense since it provides visibility under the sail and waves can wash under the foot of the sail.

How can I improve the performance of a cruising headsail?

You need to modify your deck layout so that you can move the sheet lead position when you reef the sail. It's important that the location of the sheet lead be right for the reduced sail area.

My boat does not have a spinnaker and I am considering buying one for cruising. Should I buy an asymmetrical spinnaker or a symmetrical one?

Buying new sails is an individual choice, but I would suggest an asymmetrical spinnaker. For starters you will not have to purchase a spinnaker pole and all the other spinnaker gear needed to fly a symmetrical spinnaker. Asymmetrics are easier to set and douse and are more efficient except when the wind is fairly broad, i.e., aft of 150 degrees.

Can I cut down an old headsail to make a storm jib?

I would advise against doing this unless the fabric of the old headsail is in good condition and it's of sufficient weight. Your best bet would be to have a new sail built that is engineered as a storm jib and able to handle any kinds of storm conditions.

Can I use my roller-furling sail reefed as a storm jib?

I would advise against it. The sail will not be engineered to withstand gale force conditions and you will be relying on the furling line to keep the sail from unrolling, a most unsatisfactory situation during a storm.

Do I need a separate trysail track?

It depends on the kind of boat you have. Boats below 30 feet in length do not need a separate trysail track because the sails are still fairly manageable. For larger boats you should consider a separate trysail track so that your mainsail can remain attached to the mast when it is dropped and you can easily deploy your trysail.

How important are staysails?

In the case of a working staysail they are very important. They balance the sailplan and if the sail is hanked on it allows you to ride out a squall with your headsail rolled away knowing that you have a strong sail attached in a sturdy manner. Staysails also break the foretriangle into two separate wind slots increasing the efficiency of each sail. A mizzen staysail is a great sail when the wind is aft of the beam and projected sail area counts. A "daisy" staysail can double as a Windseeker when the wind is light.

Do I need telltales on my sails?

It's not absolutely necessary to have telltales on your sails, but they do make it easier for you to see the wind flowing across the sail and to trim the sail accordingly.

When I am sailing to windward the top telltale on my genoa starts to lift first. What should I do?

The first thing you should do is move the sheet lead forward. This will close the leech of the sail and get the top to start lifting at the same time as the rest of the sail. If this doesn't work you might need to have a sailmaker take a look at the luff curve to see that it's fair and even.

When I am overpowered while sailing on a beat should I ease the mainsheet or the main traveler?

In almost all cases you should ease the traveler first. This keeps the leech of the mainsail under control and depowers the sail while still being able to generate lift from the back of the mainsail. If you have a tight vang, easing the mainsheet will accomplish the same thing, but you will be unnecessarily loading the boom at the vang attachment point.

How do I know when the mainsail is trimmed properly?

The easiest way is to sight up the leech of the sail, wind the sheet on until the top telltale starts to tuck in behind the sail and then ease the sheet out a fraction.

What does adjusting the backstay do?

Tightening the backstay tensions the headstay or bends the mast depending on what you want to accomplish. If you want to bend the mast to flatten the mainsail, tighten the backstay and ease the running backstays. If, on the other hand, you want to flatten the headsail by straightening the headstay, keep the running backstays tight as you take up on the backstay and the load will go directly on the headstay.

Do I need running backstays on my mast?

It depends on the design of the mast. If you have a heavy mast section it's unlikely that running backstays will accomplish anything. On the other hand, if you have a light bendy mast section then you can use runners to manipulate the shape of your mainsail. On some masts where the spreaders are swept back, you do not need and can't use running backstays since the sweep in the spreaders limits what you can do and how much you can adjust the mast.

How do I add power to my sails?

If the wind has died or if you hit a wave and the boat speed suddenly drops, you will need to power up your sails. The quickest and most effective way is to ease the sheets on both sails along with the outhaul on the foot of your mainsail. You can also ease the backstay and the halyards on both sails. Be sure to reverse what you have done as soon as the wind or boat speed starts to pick up.

What is most important to remember when the wind is light?

There are many things to remember. Keep your weight forward and to leeward so that you can reduce the wetted surface of the boat and allow the sails to fall naturally into their designed shape. Do not overtrim the sails and keep all movement to a minimum. Remember that some of the wind's energy is used to lift and fill sails, so make it as easy as possible for the wind to do its job. Use a smaller, lighter spinnaker, one that can be lifted easier, or use a Windseeker to generate some apparent wind before trying to use your large headsail.

When the wind is around 6–8 knots, how should my sails look?

Keep them fairly flat. It sounds contradictory to have flat sails when you want to generate power, but if the sail is too full the wind will not have the energy to make it around the bend if the sail has a deep camber. Make it as easy as possible for the wind to flow onto and off your sails. Keep the mainsail leech twisted slightly open and don't try to point until you have generated some speed. If you get the boat moving you will be generating lift from the underwater appendages, as well as sails.

Explain how the mainsail trimmer can “drive” the boat.

The mainsail is a huge sail that has a large effect on the weather helm and heel of the boat. If the sail is sheeted on too tight or if it is too high up the traveler, the helmsman will have to turn the wheel to compensate and this can slow the boat down, especially if there is a sudden puff of wind. Rather than wait for a puff of wind to hit the sails before easing the sheet, the mainsail trimmer can ease it before the wind hits the sail and save the helmsman from having to turn the wheel.

At what point does it make sense for the headsail trimmer to leave his post to leeward and sit on the rail?

As soon as the wind is steady there is less need for constant trimming. That’s not to say it’s not important to keep trimming, but often it is better if the trimmer keeps his weight on the rail rather than down to leeward making minute adjustments. This is an individual call that depends on the size and type of boat you are sailing.

How can I manipulate spinnaker shape?

There are a number of ways to manipulate the shape of your spinnaker. By bringing the clews together, for example, you add depth. You can also raise or lower the outboard end of the pole to control the amount of depth in the top half of the sail as well as its location.

Are there any rules of thumb when trimming a spinnaker?

When the apparent wind is aft of 120 to 130 degrees, keep the pole at right angles to the apparent wind to get the maximum projected area. When the wind is forward of 120 degrees over-square the pole to flatten the sail and make it more efficient for reaching. Generally keep the clews level and be careful not to overtrim the sail. When in doubt, ease out.

When would you need to band or stop a spinnaker?

Small boats in light wind don’t need the spinnaker banded or stopped with yarn, but once you get a boat over 30 feet in length and any kind of wind, it makes sense to band the spinnaker. For boats over 60 feet in length, it makes sense to stop the spinnakers with wool or use a spinnaker sock. These spinnakers are so big that they warrant being carefully packed to prevent opening prematurely.

What’s the most important thing to remember when setting a spinnaker?

There are many things to think about, but one of the most important is to make sure that all the lines are led properly and the sail is packed properly. A few extra seconds preparing to set the sail can save a lot of trouble once the halyard is hoisted.

What are some techniques for dousing a spinnaker with a dousing sock?

It's important that you use the blanket of your mainsail to help douse the sail. You need to bear away until the spinnaker gets sucked into the dead air behind the mainsail and then start to lower the dousing sock.

What are the main causes of sail degradation?

There are a number of factors that contribute to sail degradation, including excess flogging, too much sunlight, chafe, mildew, and using a sail beyond its designed wind range. Things like flogging and sunlight are unavoidable when sailing, but keeping them to a minimum is important. For example, don't motor with your mainsail flapping in the wind and make sure that the cover goes on the sail as soon as you return to the mooring.

What are some important things to note when repairing sails?

You need to know how the sail is ripped and start to repair it by working from the middle of the sail out toward the edges. It's important for the fabric to lay flat and for the ripped edges to be matched as closely as possible. When patching, be careful that you don't create a hard spot by building up layers too quickly. A hard spot will create a hinge that will give you trouble in the future.

And finally...

We have worked our way through the bulk of the book and by now you should have a reasonable understanding of the subject. Much of sailmaking and sail handling is intuitive. Some of it is learned and only time spent out on the water will teach you what you need to know. That's not all bad news; after all that's how most of us want to spend our time anyway. The final chapter in the book is the most complex, and also the most interesting. It's the theory behind how a boat sails. It's not critical to know the ins and outs of the science behind how lift occurs and what circulation is, but it is part of the overall subject and worth learning about. I encourage you to read the last chapter and to take the time to understand the content. You will be pleasantly surprised when suddenly it all makes sense.

Chapter 15

THE WIND IS STILL FREE

The Theory Behind How Boats Sail

There is nothing quite so beautiful as a sailboat slicing through clear water, sails drawing, and the soft smack, smack sound as waves lick the hull. The boat moves along as if by magic, making hardly a sound and leaving nothing but bubbles in its wake. While we can hear the boat moving through the water, we cannot see what it is that's pulling it along. It's as if an invisible hand is reaching out and gently tugging the boat forward: the invisible hand of the wind.

It's this wind that allowed our forefathers to discover new lands, allows our children to fly colorful kites, and spreads seeds across the country allowing them to germinate and grow into flowers. It's what rustles the leaves on warm summer nights and ripples the surface of the sea, making it dance in the sun as if covered with small diamonds. It's this wind that is the sailor's best friend. And for sailors, indeed for everyone, it is still free.

While the wind performs its magic equally on all sailboats, some sailors understand it better than others and are able to make more use out of each puff and gust, which in turn allows their boats to sail both faster and more efficiently. As a result, if you're going to be a good sail trimmer, and by extension a good sailor, you need to be able to "see" this wind and understand how it works so that you can make the most of its power. Of course, the way in which a sailboat sails before the wind, i.e., on a broad reach or run, is fairly straightforward. Basically the boat's sails project a surface that captures the energy of the moving air, and the boat is propelled through the water like a leaf being blown across a pond. While you will never be able to see wind with your naked eyes, you *will* be able to see it with your mind's eye, and that's as good, if not a better way to know the mysterious ways of moving air. How a sailboat sails to windward, however, remains one of the most wonderful mysteries of our planet, and will be the focus of this chapter.

Not surprisingly, the subject of how a boat sails is not only complex, but fairly controversial within the scientific community, and it's not hard to understand why. No one can actually see the wind, and while water channels and wind tunnels make it possible to watch the flow over various types of hydro- and aerodynamic foils, these tests have all been done on a reduced scale and in a controlled environment, which can be far different from what is actually experienced at sea. Fortunately, countless hours of computer-aided research have resulted in a general consensus as to how and why a boat sails into the wind. And while it's a complex consensus and for a non-physicist the calculations might as well be Zulu (I certainly don't understand them all!), the basic principals are readily understandable to the layman. Note that for some well-written and deeply insightful lessons on the subject beyond what will be provided here, you can read a series of articles first published in *Sail Magazine* by Arvel E. Gentry and later repub-

“While the wind performs its magic equally on all sailboats, some sailors understand it better than others and are able to make more use out of each puff and gust, which in turn allows their boats to sail both faster and more efficiently.”

lished in the book, *The Best of Sail Trim*, that looks at the topic in even greater detail. Mr. Gentry once worked at Boeing Engineering and wrote the articles with the idea of correcting many of the so-called mainstream theories of how and why sails work. In my opinion he succeeded.

For an even more in-depth look at the science behind sails and foils, you can take a look at the book, *Aero-Hydrodynamics of Sailing*, by C. A. Marchaj. It's complex stuff and not for the faint of heart, but it will answer any questions you might have, and then some. Some day when the rain is falling and it's cold and raw outside, you might want to pick up these two books, light a fire, and spend some time getting to the bottom of the subject. Meanwhile stick with me. I will give you just enough information to be dangerous. With any luck, it will also make you a better sailor along the way.

Early Theory

When I first learned about boats and sails, I read a number of the simple theories that were eventually upgraded by Mr. Gentry. They certainly seemed to make sense at the time. But while many of them were grounded in hard scientific fact, they overlooked some basic problems that both research and common sense later revealed. For example, while most sailors learn that a sail is shaped like the wing of an plane, and that since planes can fly it must hold true that a sailboat will sail, this line of reasoning ignores one big difference, namely that planes have an engine, and that without it, no matter how hard the wind blows and how much you will it, the plane will never get off the ground. Sailboats, of course, although they have them, don't use their engines when sailing, so how can they move, sometimes at good speeds, using just the wind?

Taking a closer look at the airplane analogy, the common theory behind powered flight is that the air passing over the curved upper surface of an airplane's wing has to travel a longer distance than the air travelling under the flat lower surface, and if the wind has further to travel it must move faster to get to the end at the same time as the wind on the bottom (Figure 15.1). According to the renowned eighteenth-century Swiss scientist, Daniel Bernoulli, for any fluid – and

**Air flowing over the top of a wing travels further than wind on the bottom.
To arrive at the end of the wing at the same time means that the air on top
must travel faster = more speed = less pressure.**

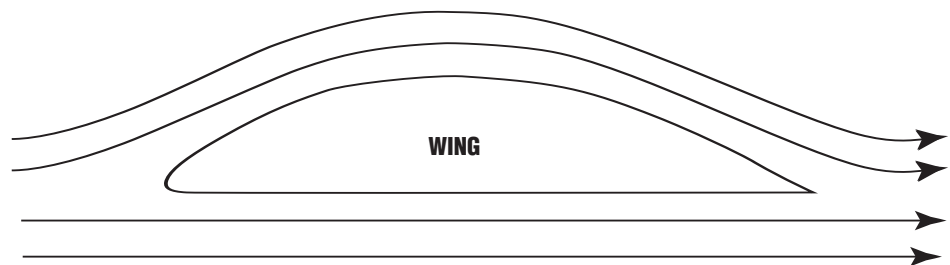

DIFFERENT WIND SPEEDS

Figure 15.1

The common theory behind powered flight is that the air passing over the curved upper surface of an airplane's wing has to travel a longer distance than the air travelling under the flat lower surface, and if the wind has further to travel it must move faster to get to the end at the same time as the wind on the bottom.

remember air is a fluid – *pressure plus speed is constant*. Bernoulli further declared that if speed increases then pressure will drop, and conversely that if speed drops then the pressure will increase. The good news is that Bernoulli was absolutely correct and more than 250 years later his theory remains unchallenged.

Applying the airplane analogy to a boat's sails, the theory held that, like the airplane wing, the air moving over the leeward surface of the sail simply had to travel farther and therefore went faster than the air going across the windward surface of the sail. These differences in speed created a difference in air pressure between the two regions. And since an area of high pressure always tries to move toward an area of low pressure, a resultant force was applied to the windward side of the sail with the result that the boat started to move. Like most sailors, I loved this theory because it was easy to understand. The top of the airplane wing was the same surface as the outside, or leeward side of the sail, and combined with the keel to stop the boat from slipping sideways, it simply moved forward. You can imagine how I felt when it was pointed out that if this theory was true, how then could a plane fly upside down? Rack up one point for common sense.

So how *does* an airplane fly upside down? As a small child I used to love traveling in our family car. I would sit in the back with my hand out the window and feel the pressure of the wind against my palm. Once my Dad got the old Valiant up to a decent speed, I could ever so slightly tilt my fingers upward, and suddenly the pressure of the wind started to force my hand up. The faster the speed of the car, the less I had to tilt my hand to get it to rise. The same thing happened when I reversed the angle and pointed my fingers down. Suddenly my hand was forced downward. I was actually proving Sir Isaac Newton's third law of motion, which states that for every action or force in nature there is an equal and opposite reaction. This action of deflecting the air down by tipping my hand slightly, was producing an equally forceful action upward. In other words, it was giving my hand lift. The same can be done by offering an angle of attack by any surface, even one curved on one side and flat on the other. With the engine helping, the plane can fly upside down, probably less efficiently, but upside down nonetheless.

If that's the case then why aren't wings just flat boards? If it's the engine that helps a plane fly, why are the wings curved in an aerofoil shape? Good question, the answer to which is that, at least in part, the wing of a plane is curved so that the wind hitting the wing has a more gentle introduction to the surface, which helps keep the flow attached to the wing. If there were hard edges the wind would have a difficult time attaching itself, there would be increased turbulence and the wing wouldn't provide as much lift. And it turns out that the same is true for sails.

Ultimately, the difference comes down to a contrast in power and wind speed. In other words, there are lots of things that airplane wings can do that sails cannot do, simply because of the power supplied by an airplane's engine and the speed of the air flow over the top and bottom of the wing. Made of thin pieces of fabric or membranes, the pressure differentials generated according to the classical theory of sail dynamics would never be enough to carry a sailboat through the water. In order for a sail to function there needs to be something more.

“The same thing happened when I reversed the angle and pointed my fingers down. Suddenly my hand was forced downward. I was actually proving Sir Isaac Newton’s third law of motion, which states that for every action or force in nature there is an equal and opposite reaction.”

“The result of this circulation is that the air passing along the leeward side of the sail is given a boost in speed while the air on the windward side gets bunched up, making the depth of the foil that much more effective.”

That “something more” is called circulation, and involves the movement of air over the surface of the sail in such a way that it increases the aerodynamic efficiency of the overall foil. Specifically, when a sail is oriented for sailing close-hauled, the wind not only passes over the sail from front to back, but a thin layer of air actually travels in the opposite direction, powered by vortices off the leech, which causes the pressure differential between the windward and leeward sides to be that much greater. The result of this circulation is that the air passing along the leeward side of the sail is given a boost in speed while the air on the windward side gets bunched up, making the depth of the foil that much more effective. In many ways the basic theory is left unchanged, i.e., air speed and pressure differentials on either side of the sail are causing it to create lift. It’s just that now we are filling in the extra parts that actually make the theory work.

Basic Concepts

If you are scratching your head right now, don’t worry. Much of this theory is counterintuitive – again, its pretty controversial stuff – and involves some fairly esoteric aerodynamic theory. Still, if we break things down into separate parts, they are much easier to understand. There are also a number of ancillary points we need to come to terms with, including such concepts as lift, drag, boundary layers, attached flow, separation, pressure gradients, and angle of attack. Note that in the beginning we will be talking about headsails alone since, without the presence of a mast along the leading edge, they present a much simpler picture aerodynamically. Once we get the notion of how jibs and other simple foils work, we will move on to the mainsail, as well as how it is that the jib and main work together to create a situation in which the sum is substantially greater than its constituent parts.

The Boundary Layer

This concept is central to modern sail theory and basically states that the surface of the sail, no matter how smooth, presents an area of friction to the air passing over it, a so-called boundary layer of slower-moving air around the sail. All air particles have a certain amount of viscosity, or stickiness to them, so

Air particles closest to the sail surface are slowed down by the surface. Each successive layer feels the effect.

These particles are far enough away from the foil to not feel any of its effect.

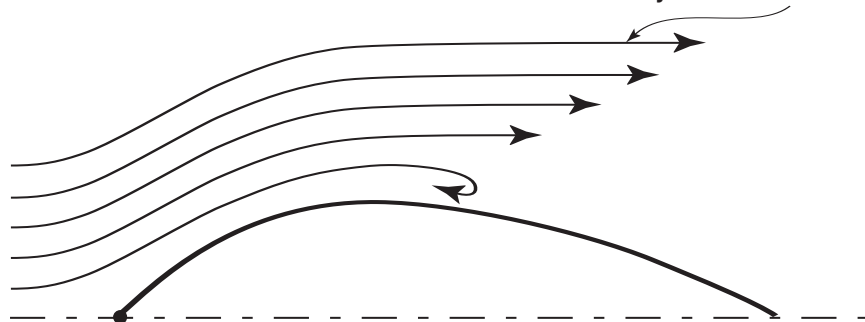

Figure 15.2

All air particles have a certain amount of viscosity, or stickiness to them, so while the air particles closest to the solid mass of the sailcloth adhere to the fabric, they in turn have an effect on each subsequent layer of air.

BOUNDARY LAYER

while the air particles closest to the solid mass of the sailcloth adhere to the fabric, they in turn have an effect on each subsequent layer of air (Figure 15.2). This thin layer moves at the same speed as the surface to which it is attached, in other words the attached air has zero speed with respect to the airfoil. The influence of the fabric is diminished the further you get from the sail, until it has no effect on the passing particles and they move at the same speed as the rest of the surrounding air (Figure 15.3).

Attached Flow

A condition of attached flow exists when there is a smooth transition, without excessive turbulence, from the boundary layer to the surrounding air. This condition is crucial to sail performance since without it a sail cannot obtain lift. Specifically, Bernoulli's principle will not be able to come into play.

There are three types of attached flow (Figure 15.4). Near the leading edge of an airfoil there is a smooth change of air speed within the boundary layer

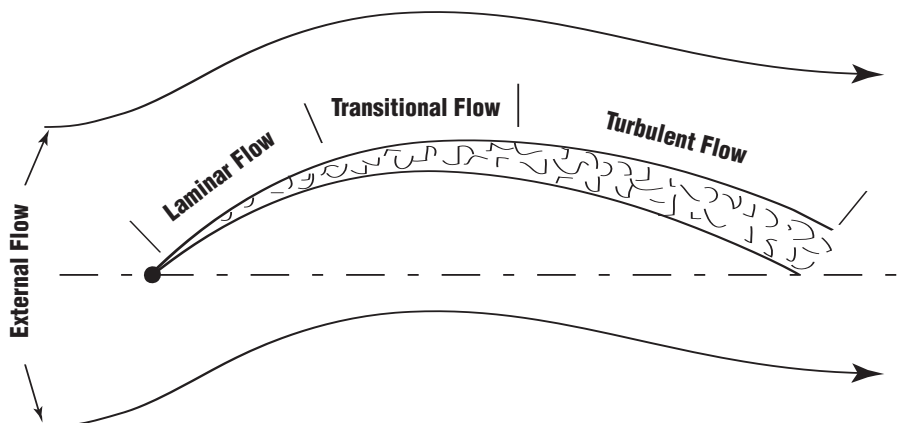

Figure 15.3

The influence of the fabric is diminished the further you get from the sail, until it has no effect on the passing particles and they move at the same speed as the rest of the surrounding air.

Figure 15.4

There are three types of attached flow.

from the airfoil surface to the edge of the boundary layer. This is called the laminar boundary layer and the flow is called laminar flow, i.e., flow in which the air molecules are both moving in parallel and interacting with one another without the interference of turbulence. Just aft of the laminar flow is an area where the air encounters a certain amount of natural turbulence. This can be caused by any number of things, from seams to a rough fabric surface. The smooth changes in speed within the laminar flow start to give way to a more erratic type of flow, and this area becomes known as the transitional region with the flow named appropriately, transitional flow. Moving further aft, the transitional flow becomes even more agitated and the boundary layer becomes known as the turbulent layer, and the flow as turbulent flow. Turbulent flow should not be confused with separation since even though the air is turbulent it is still attached to the sail, i.e., Bernoulli's principle is still in effect. Of all three, laminar flow is the most desirable, followed by transitional and then turbulent. The goal of a sail trimmer is to keep all three types of flow attached to the sail.

Separation

The opposite of attached flow is separation, when the air no longer travels smoothly along the sail, but is broken up by turbulence. Remember that a thin layer of air passing over a sail actually sticks to its surface and moves with the sail. This air is in fact moving in the opposite direction to the rest of the air, or the "external flow" since the boat is sailing forward while the wind is blowing aft. This negative or opposite flow exerts an influence on the adjacent air and tries to drag it along with the sail, and the slower that adjacent air is flowing, the more chance the negative air has of succeeding. The problem arises if there is too abrupt a transition between the boundary layer and external flow, for example, where the air is forced to make an abrupt turn around the leeward side of the luff. In that case the laminar flow will be broken up into speed-robbing vortices and there will be separation (Figure 15.5).

Figure 15.5

The wind gets to the deepest part of the sail too quickly and starts to separate.

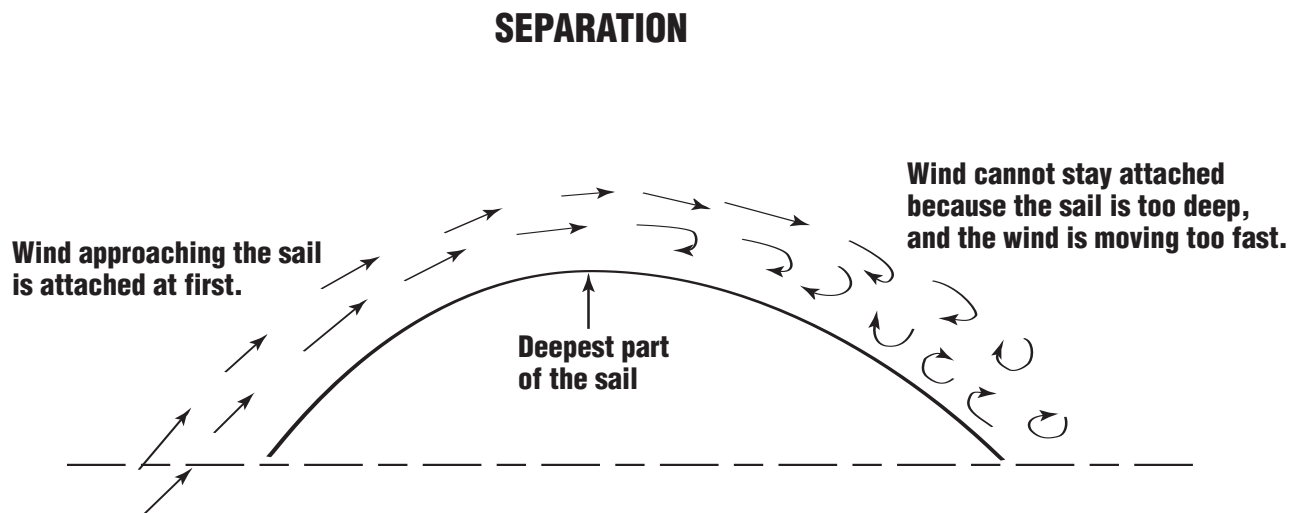

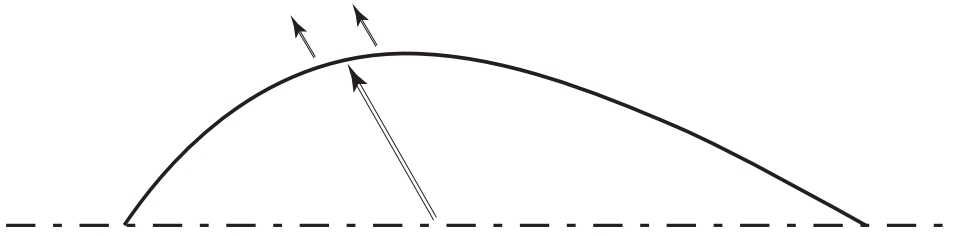
**Figure 15.6**

Curvature of the sail directs the force in a certain direction.

Pressure Gradients

In the atmosphere, winds flow from areas of high pressure toward areas of low pressure, and the same holds true for sails, i.e., if two different pressures are created on either side of a sail, the air on one side will try to get to the air on the other side. If there is a membrane or sailcloth in between, the pressure will be constant and a force will be exerted in a direction created by the curvature of the sail (Figure 15.6). The resulting force will move the boat forward. Also bear in mind that compressed air flows faster than non-compressed air in accordance with what is known as the venturi effect. This becomes important in areas of the rig where the air is squeezed together, for example, between a headsail and the main. As is the case with weather systems, the difference in the amount of pressure and the distance between the two pressure areas will dictate the speed of the air flow.

The Angle of Attack

The angle of attack refers to the angle of the sail relative to the direction of the wind. In fact, there are two angles to talk about. One is the angle of the overall sail relative to the wind, and the other is the angle of the luff of the sail relative to the wind (Figure 15.7). The latter is self evident; the luff should be in line with the direction of the wind if the sail is trimmed properly. The former is defined as the angle of the chord of the sail relative to the wind. As either of these angles change, the effect the wind has on the sail changes, thereby changing the performance of the boat.

ANGLE OF ATTACK

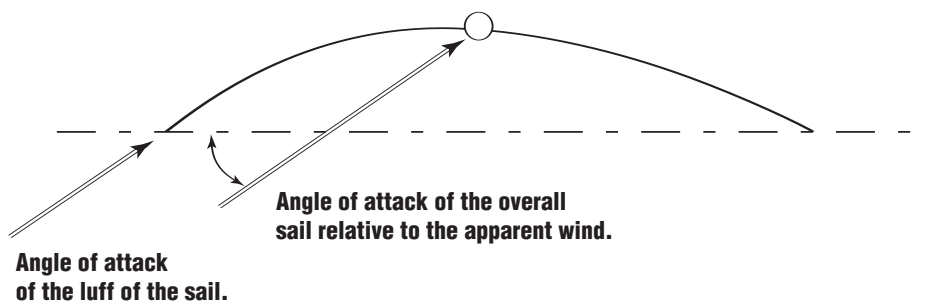
**Figure 15.7**

There are two angles of attack to keep in mind when thinking about the way sails work.

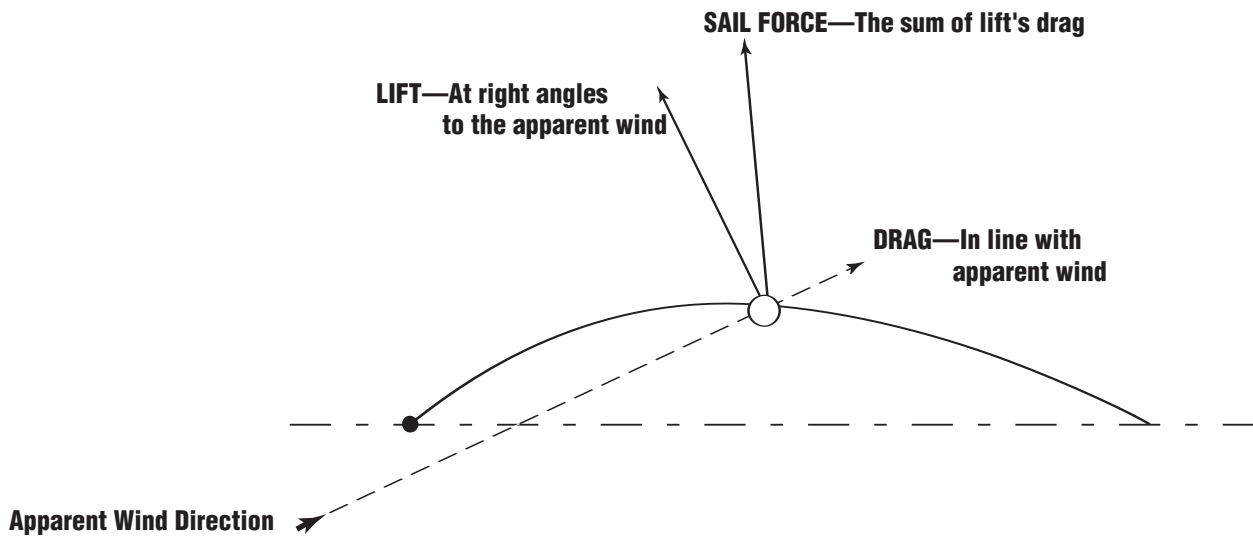

Figure 15.8

If a boat is accelerating, the lift forces that are moving the boat forward must be greater than the drag forces that are holding it back.

Lift Versus Drag

In any given wind speed, if a boat is accelerating, the lift forces that are moving the boat forward must be greater than the drag forces that are holding it back (Figure 15.8). These forces apply to both the sails moving through air and the underwater appendages, i.e., the rudder and keel moving through water. The proportion of lift to drag is fundamental to a boat's performance and should always be remembered when trimming sails or balancing a boat for optimal performance. The late Bruce Banks, founder of Banks Sails, once wrote, "Only sails drive the boat forward, everything else is holding it back." It's a sentence well worth remembering if you are looking for performance.

Modern Theory

Now that we've nailed down both some basic terms as well as the immediate effects that wind has on a sail, it's time to try to get our heads around the theory behind why a boat sails. First, let's look at a simple representation of what hap-

FLYING A FLAT SURFACE

Pressure forces on either side of a flat surface are the same; there is no lift.

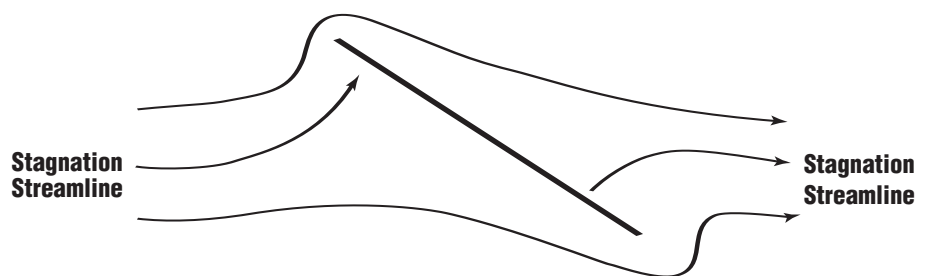

Figure 15.9

A simple representation of what happens to the wind when it is presented with a flat surface.

pens to the wind when it is presented with a flat surface (Figure 15.9). This is actually an incomplete representation of what happens in the real world, but it serves as an instructive starting point. In the diagram you will see that the flow lines have been drawn so that, although reversed, they are the same on both sides of the flat surface. Because the flow lines are the same on both sides, the pressure forces on either side will be the same. This being the case, without a pressure gradient there will be no lift, and therefore this particular surface, at least as illustrated, should not be able to fly. A further indication that the flow did not exert any net force on the surface is seen by the direction of the flow after it exits the surface. It is exactly the same as it was before it hit the surface. These lines were drawn with the help of mathematical equations that calculated how they would look relative to the surface. We know the calculations are correct, yet we also know that even flat surfaces do provide some amount of lift. If this is the case, what are we missing in our analysis?

In fact, two key points are missing. On closer examination you will note that the air flowing around the edges of the surface make a pair of sharp turns, and we know that when any fluid makes a sharp turn there is an increase in speed, especially on the outer edge. Think of how when a river makes a sharp bend the water on the outer edge speeds up. Same thing here. The air speeds up as it makes the turn around the leading and trailing edges, in a situation that is analogous to the luff and leech of our sail. In fact, this speeding up, especially at the back end, is the key to the overall theory, but before going into it in full detail, let's go back to the flat surface.

The Kutta Condition

We know that the air that flows off the back end of a sail that is trimmed properly does so with equal pressure on both sides. This fact of aerodynamics is known as the Kutta Condition after the scientist who discovered it in 1902. It's important for us to understand the Kutta Condition because it is relevant to the way the entire flow field around the sail is affected. Visualize what would happen if the Kutta Condition was not a reality and the air coming off the leeward

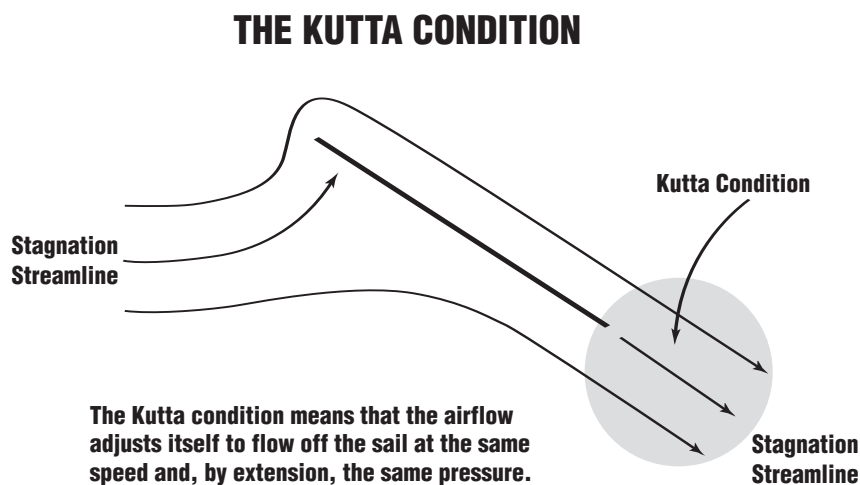

Figure 15.10

The air flow around the total region of the airfoil adjusts itself so that the air flows off both sides of the sail at the same speed and pressure.

side was flowing faster than the air coming off the windward side (as many of the earliest theories claimed). There would be two different pressures on either side of the sail (per Bernoulli's theory), and once the barrier of the sail was no longer there, nothing would stop the high-pressure air from taking over and pushing into the low-pressure region thereby negating the lift created by the sail. What really happens is that the air flow around the total region of the airfoil adjusts itself so that the air flows off both sides of the sail at the same speed and pressure. In other words the Kutta Condition prevails (Figure 15.10).

So, we know that the air speeds up at the edges of the surface, and it exits the surface at the same speed. How does this relate to lift and the mechanics of a sail? Enter the boundary layer. This invisible layer around the sail has its own characteristics, and they affect the flow of the air around the surface. If no boundary layer existed, the air would quite likely be able to make the sharp turns at the edges of the surface without any problem. Instead, it is trying to make the turn *within the context of the boundary layer*, and scientists have discovered that while wind within the boundary layer has no problem speeding up, there is a certain amount of momentum created by the boundary layer that prevents it from slowing down and making sharp turns.

Creating a Vortex

So picture the air flowing off the back end of the surface. It gets to the edge and attempts to make the sharp turn as it rejoins the external flow of air. However, the momentum created by the boundary layer prohibits the air from making the turn, so instead, it continues beyond the edge, tripping up on itself until the air starts to swirl in a small vortex (Figure 15.11), which is swept downstream from the sail. Because there is a continual flow of air across the sail, a continual stream of vortices is created, collectively referred to as the "starting vortex," which turns out to be critically important to the whole theory of why a boat sails into the wind (Figure 15.12). It is so important that we will take a closer look at what it does before going back to the flat surface to see what's happening at the front end.

Vortices Create Circulation

Scientists have discovered that any surface, be it a flat board or a curved sail, when presented to the wind starts to generate a circulation around that surface,

CREATING A STARTING VORTEX

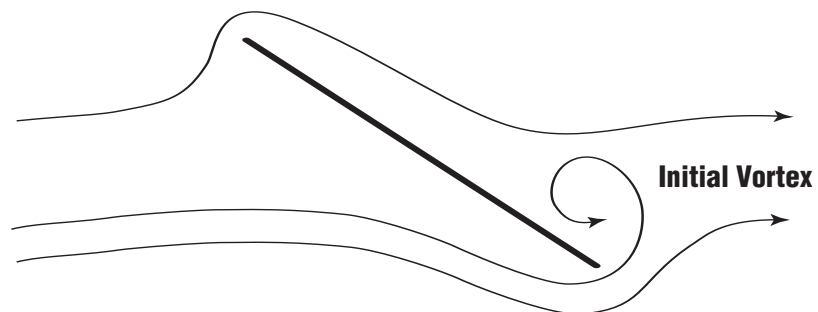

Figure 15.11

The momentum created by the boundary layer prohibits the air from making the turn, so instead, it continues beyond the edge, tripping up on itself until the air starts to swirl in a small vortex.

STARTING VORTEX CREATES CIRULATION

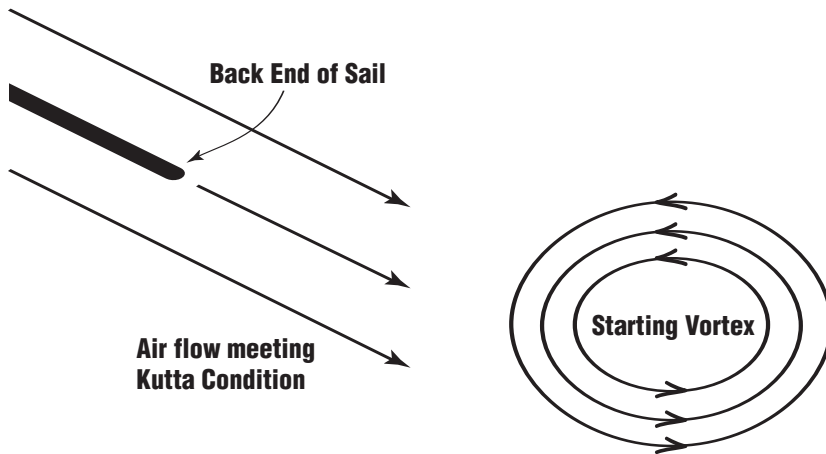

Figure 15.12

The initial vortex is then swept downstream. Because there is a continual flow of air across the sail, a continual stream of vortices is created, collectively referred to as the “starting vortex.”

in other words a *thin layer of air starts to rotate around the surface*, often in directions that are far different from the surrounding layer of air. This circulation is in fact created by the small vortices that spin off the back end of the foil (or flat surface if that’s what you are working with). The circulation flow is strongest near the foil and becomes progressively weaker as it moves away from it. How the vortices create the circulation can be illustrated with a mechanical analogy (Figure 15.13). If you think of the vortex as a small cog spinning around, and know that air has some viscosity, then you will understand that the spinning air has an effect on all the air particles with which it comes into contact. Using the small cog analogy, the spinning particles start to create a circulation flow around the sail. (Note that Figure 15.13 is a schematic representation of what is going on, and as explained above, circulation takes place very close to the sail and is not a great

VORTICES CREATING CIRCULATION

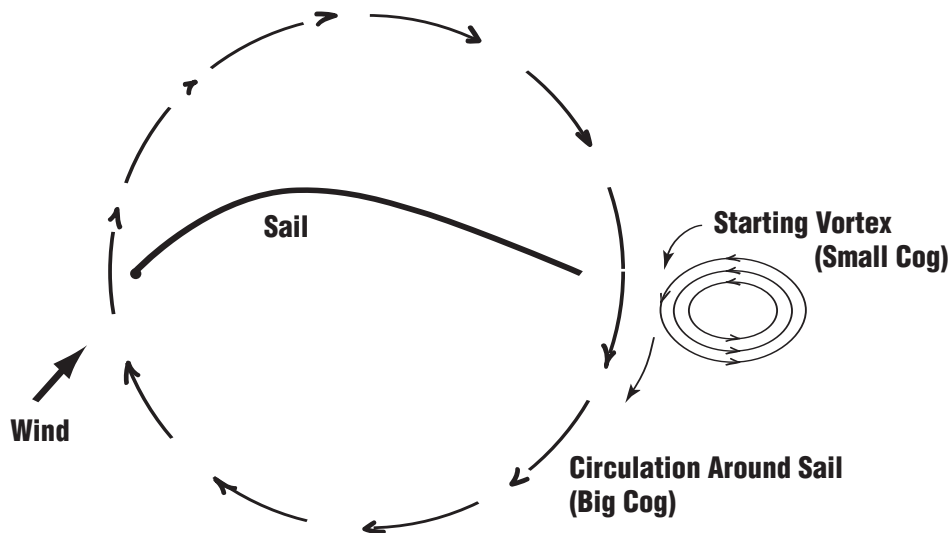

Figure 15.13

The starting vortex creates a circulation around the sail.

Combining regular flow with circulation flow

- Leeward side of sail: regular flow + circulation = twice the speed = low pressure.
- Windward side of sail: regular flow - circulation = half the speed = high pressure.

circle of air revolving the sail at a distance as shown in the diagram.) You might think that it would just create another small cog spinning in the opposite direction, but with the surface of the sail blocking the way, it can only create a large circulation, and indeed this is what happens. The circulation is also encouraged by the general air flowing down the lee side of the sail. So now there is an immediate flow close to the surface of the sail and a general flow passing over and around the whole sail. When these two movements of air collide, lift is created.

Streamlines

Let's go back to the front of the sail again. Before any circulation was created you had a circumstance as shown in Figure 15.14. We now need to label some parts of this diagram, and I have done so using the terminology created by the scientists. The lines of wind flowing across the sail are known as streamlines. Between the flowing streamlines are two stagnation streamlines, i.e., streamlines that end or begin abruptly. These are created by the vacuum that arises when the flowing streamlines separate and attempt to go to either side of the surface or when flowing streamlines are joined at the leeward side of a surface. The surface breaks the flow of the wind, one set of streamlines heads for the windward side of the surface, and the other heads for the leeward side. An inevitable neutral vacuum is created, and this area becomes known as the stagnation streamline. One of each kind occurs at opposite ends of a sail. Figure 15.14 shows the stagnation points quite close to the edges of the sail. Note that this is before any circulation is created and that, as was the case with the first schematic, we are dealing with an incomplete picture. Now that the illustration is labelled, let's see what happens

BEFORE ANY CIRCULATION IS CREATED

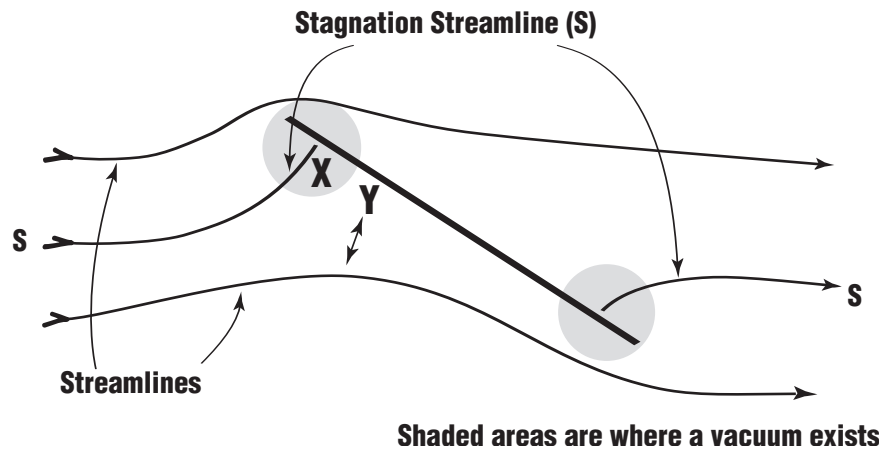

Figure 15.14

Before any circulation is created.

COMBINING REGULAR FLOW WITH CIRCULATION FLOW

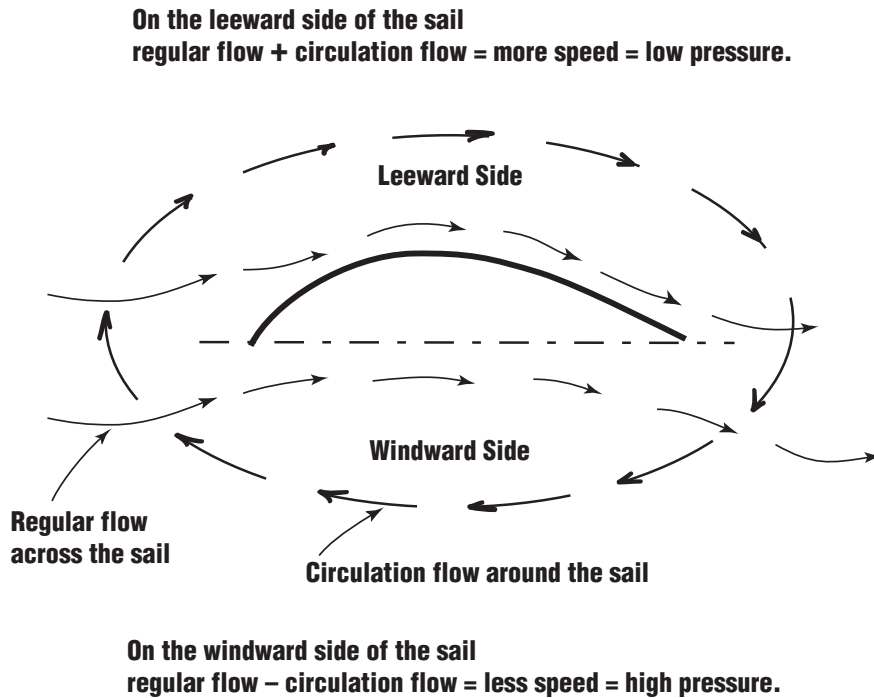

Figure 15.15

With circulation even more air is flowing across the leeward side, since the velocity of the regular streamlines has been added to the circulation flow.

when some other the forces created are added to the equation. This is important because the new equation has an effect on the stagnation streamlines.

Creating Lift

Without circulation, air was flowing across the leeward side of the surface. With circulation *even more air* is flowing across the leeward side, since the velocity of the regular streamlines has been added to the circulation flow (Figure 15.15). On the windward side the opposite happens since as the regular streamlines come into contact with the circulatory flow, they start to cancel each other out.

All of a sudden two things are happening. Slow-moving (read high-pressure because of Bernoulli's principle) air is on the windward side of the sail and fast-moving (low-pressure) air is on the leeward side. This creates an accentuated pressure gradient, and by extension, lift. The old theories thought this was happening, i.e., that there was a pressure gradient, but they didn't take into account the effect of the circulation and the fact that it adds velocity to one side and reduces it on the other, which makes a dramatic contribution to overall lift. And that's only the half of it, since the meeting of these two air streams, the external flow and the circulating air, also affect the location of the stagnation point, and because of it, a phenomenon called upwash occurs.

Upwash

Upwash occurs at the front or leading edge of the foil. Look at Figure 15.14 again. Note how the leading stagnation streamline comes into the surface quite close to the front edge of the surface (marked with an X) and that no circulation has been factored in at this point. Aft of the stagnation streamline (a distance marked with

UPWASH

With Circulation — Note that the stagnation point has moved quite a bit because the regular flow and the circulation flow have canceled each other out. Also the Kutta Condition has been met.

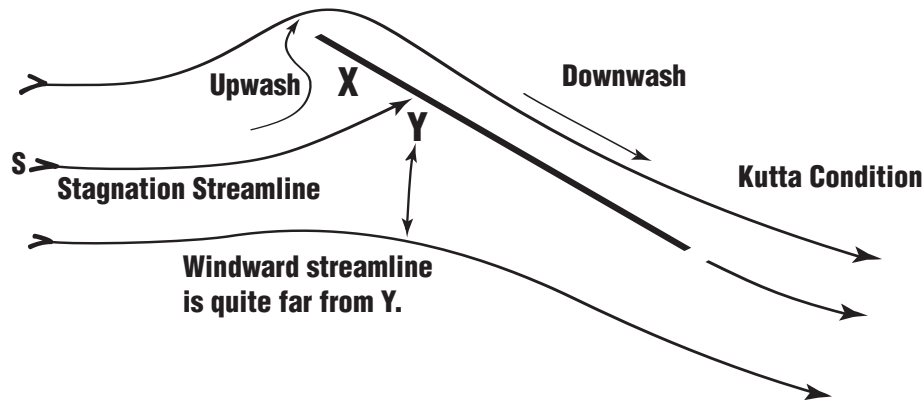

Figure 15.16

Upwash occurs as the air in front of the stagnation streamline heads for the leeward side of the sail.

a Y on the diagram) the windward streamline is quite far from the airfoil surface. Because it is far away we can expect it to be moving fairly slowly. (Since the closer the streamlines are, the more speed they have, just like isobars on a weather map). Therefore, circulation flow, or what there is of it at this point, will be about the same speed as the windward streamline, but moving in the opposite direction so the two forces cancel each other out and the point at which the stagnation streamline comes into the airfoil shifts aft, as seen in Figure 15.16. The external air flow is moving so slowly at this point that the circulation flow is not only able to cancel it out, but even *move it in the opposite direction*, i.e., make the flow change direction and go around the front edge of the airfoil. Therefore, air that was once destined to flow past the windward side of the foil is now being diverted around the leeward side, further increasing the pressure gradient. *This flow around the front edge is called upwash.* Once those air particles get past the deepest part of the sail and begin flowing toward the leech of the sail, *the flow is called downwash.*

This dynamic can be summed up by saying that an aerofoil actually “feels” the foil long before it gets there, and it starts to separate. If you have driven in a snow storm and watched the flakes coming at you being diverted over the hood of the car long before they get to the windshield, or watched water flow around boulders in a river, you will have witnessed this phenomenon. This phenomenon helps create more lift since the upwash at the leading edge of the sail accelerates as it goes around the front edge of the foil while the air diverted to the windward side is a bit lazy, i.e., it does not want to move up into the concave area created by the foil (toward Y in Figure 15.14) and so it sort of hangs around waiting to hook up again with the air flowing past the leeward side, creating a region of high pressure. Of course, the fast-moving air on the lee side of the sail creates a low pressure area, especially near the front of the sail, which adds even more to the pressure gradient, creating lift.

In Summary

With the boundary layer creating vortices, the vortices creating circulation, the circulation affecting the speed of the flow and the speed of the flow affecting the pressure on either side of the foil, you end up with a surface that creates much more lift than in the original sail theory model. If all of this seems a bit much to come to grips with, let me try to put it all into plain English. Have you ever played golf? If you are like me you have probably sliced the ball a few times (in my case many times). This slice is nothing more than the ball spinning because of the way you hit it, and the spinning creates circulation, which in turn bends the flight of the ball, or “lifts” it to one side. Baseball is another example. If the pitcher wants to throw a fastball he throws a ball with little or no spin to it. That way the ball flies straight toward home plate. If, on the other hand, he wants to throw a curve ball, he throws it with a lot of spin on it. The spinning creates circulation, and this circulation, when added to the normal air flow on the ball, creates two different pressure areas on either side of the ball. On one side is high speed and low pressure, and on the other side is low speed and high pressure. The ball will curve in toward the area of low pressure.

Circulation in Practice

Let’s now think about a boat coming out of a tack. As the bow of the boat moves through the eye of the wind the sails are just flapping. Obviously there is no flow, no attached air and none of those little vortices needed to start the circulation. As the helmsman bears away he presents an angle of attack to the wind, and as soon as the air starts to flow over the sail small vortices begin forming along the trailing edge. The vortices gradually begin to create circulation, but as you can imagine it takes time and effort. The vortices are only small cogs, and the circulation is a big wheel. In light air this takes even longer because the vortices are small and weak. Conversely, in stronger winds, the circulation begins sooner, and the boat is able to get up to speed and pointing much quicker. It’s important to understand this because if you are the sail trimmer or helmsman you need to know that each time you make a move that causes the circulation to be disrupted, it takes time before it gets back to a steady state and provides the maximum amount of lift. This is why you will see the biggest difference between a good helmsmen and good sail trimmer and a bad helmsmen and bad sail trimmer when sailing in light winds. It takes that much longer to crank up the old circulation/lift machine. It is one of the reasons why sailing is such a fascinating and challenging sport.

High-Aspect Versus Low-Aspect

One more variable can be tossed into the mix. The aspect ratio of the sail, or the ratio between the height and width of the sail, will also have an effect on how quickly circulation can be established. A high-aspect sail will generate circulation more quickly than a low aspect sail, and will achieve the same percentage of lift in much less time. This is basically because the wind does not have as far to travel around a high aspect sail, and therefore it can start to get the circulation going

“This slice is nothing more than the ball spinning because of the way you hit it, and the spinning creates circulation, which in turn bends the flight of the ball, or “lifts” it to one side.”

Figure 15.17

Long, narrow keels are quick to generate lift, and the result can be felt in the way the boat sails.

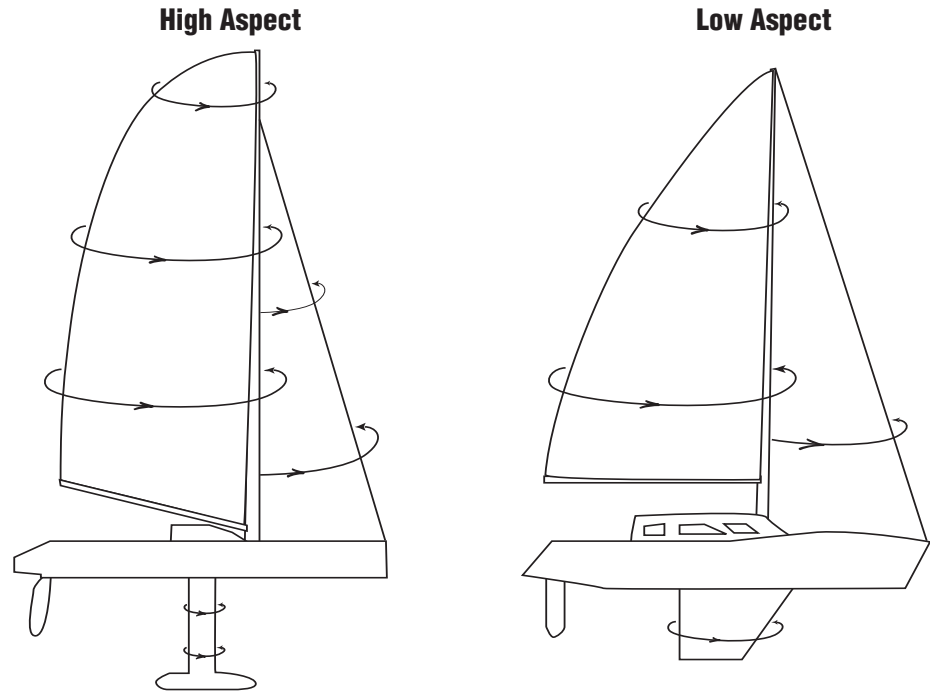

**High aspect sails and appendages are quick to generate lift.
Low aspect sails and appendages take longer.**

that much sooner. This is why dinghies are much more responsive than keel boats. It is also why modern rigs are tending more toward high-aspect sails rather than the squat sails found on older boats.

If this is true for sails it must also be true for the appendages below the surface of the water. We know that the high-aspect keel on a modern racing boat like an Open 60 or a Volvo 60 is infinitely more responsive than a short, wide keel found on an old IOR boat. These long, narrow keels are quick to generate lift, and the result can be felt in the way the boat sails (see Figure 15.17). Compare a full-keel cruising boat with a fin-keel racing boat, and the fin keel always wins. Most sailors do not give any thought to that part of the boat dragging through the water when they look up at the sails flying through the air, but the two go hand in hand. The yacht designer spent many hours planning it that way, so bear this in mind and don't fight it.

You now have a fairly clear picture of how a surface creates lift. The “surface” we have been referring to is actually the jib (or the main on a boat with no headsail) and things get to be even more interesting when you add a more complicated sailplan. For example, we all know that most boats also carry a mainsail, which creates its own circulation. And we also know that adding a mainsail to a sailplan increases the overall efficiency of a boat. But until now the reason for this increased efficiency was wrongly thought to be because of the “slot effect,” with the “slot” being that area between the leech of the headsail and the lee of the mainsail (see Figure 15.18). Old theories claimed that

THE SLOT EFFECT

The Slot (shaded area)—The headsail and mainsail circulations cancel each other out in the slot.

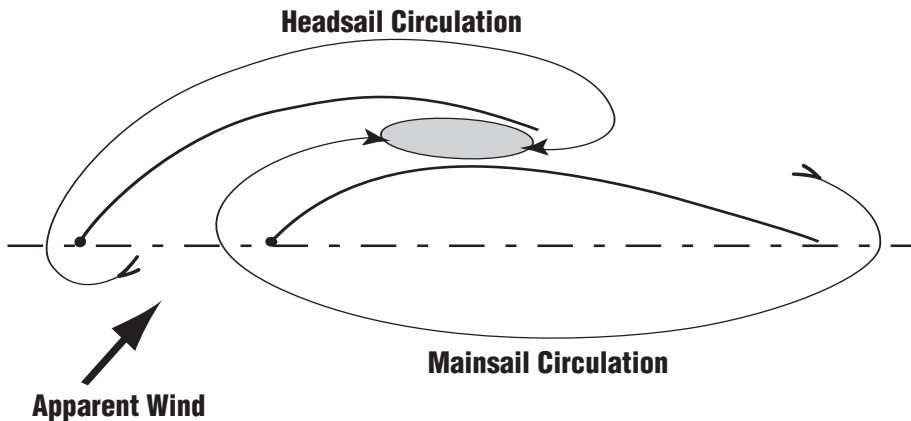

Figure 15.18

Two circulations work against each other to dramatically reduce the flow.

the air funneling into this slot increased in speed and revitalised the flow along the backside of the mainsail, thereby making the mainsail more efficient. Unfortunately, that theory was wrong. The good news, however, is that we now know what really happens, and it's all good stuff. If you are interested in how the two sails work together stick with me, grab another cold drink, and let's move on to Phase Two.

Adding a Mainsail

Before we can put the two sails together, we need first to look at the mainsail alone. Like the jib it has its own flow pattern and area of circulation. For it to be an efficient foil, the flow of air must be attached to the sail at all times, and the Kutta Condition must be met for the air coming off the leech of the sail. In fact, the flow of air around a mainsail is much the same as that around the headsail, although in the case of the main there is a large mast at the leading edge, and not a small headstay. The mast does have some effect, but as you will see later in this section, it's not a big one. Again the boundary layer at the aft edge attempts to make the sharp turn around the corner, but boundary layers being boundary layers, the air does not make the turn gracefully, and small vortices are created, which begin a circulation around the mainsail. Once again, this circulation increases the speed (and reduces pressure) on the lee side of the mainsail and decreases speed (increases pressure) on the windward side. Note, however, that if we add a headsail, the two areas of circulation overlap in the gap between the back end of the headsail and the area to leeward of the mast. This is the exact area where we used to think there was an *increase* in flow, but as you can see in Figure 15.18, the two circulations work against each other to dramatically *reduce* the flow.

THE ART AND SCIENCE OF SAILS

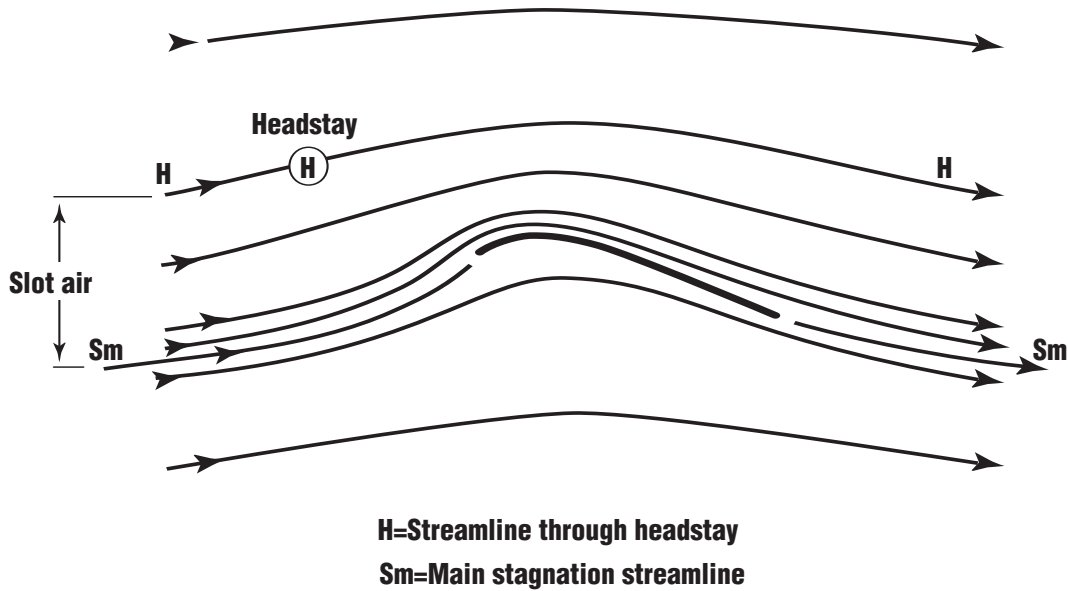
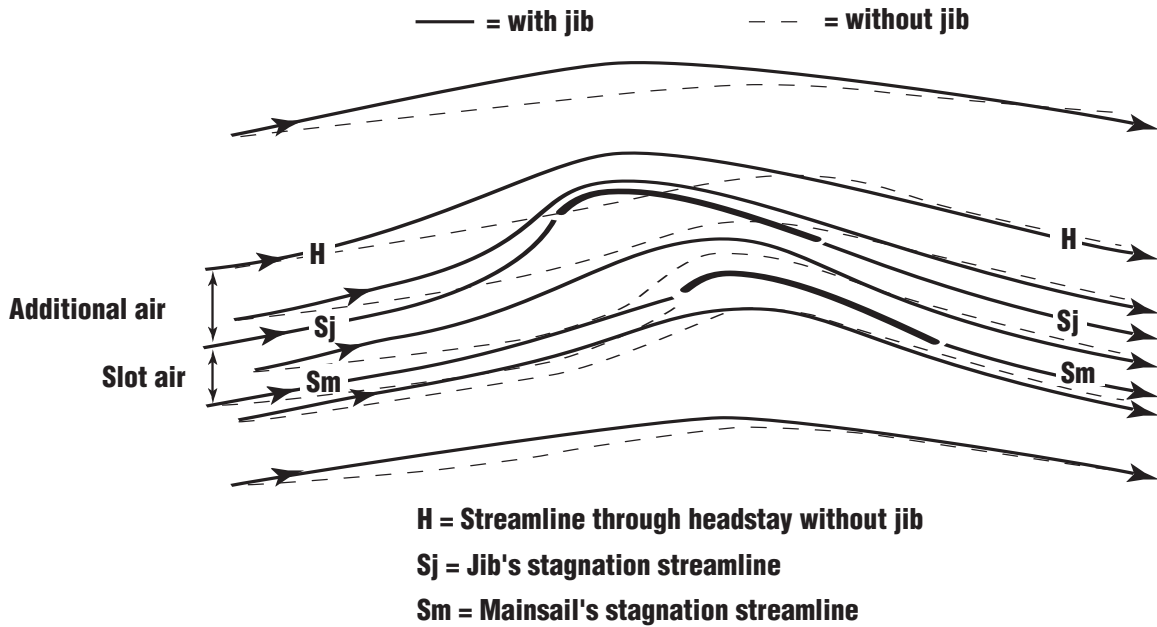

Figure 15.19

With the mainsail only, the stagnation point (Sm) connects with the sail on the windward side just aft of the mast.

In some ways this is a good thing. The problem with the old theory of the increased flow revitalising the air on the back side of the main was that the sudden increase in speed would soon have to face a sudden decrease in speed toward the back end of the sail to meet the Kutta Condition. As we discussed, the boundary layer does not like sudden decreases in speed and they tend to make it separate from the surface, which is exactly what we do not want to have happen. Fortunately no sudden increase in flow occurs and therefore no sudden decrease is necessary, and the boundary layer remains attached.

Let's look at Figures 15.19 and 15.20. These diagrams were generated using an analog field plotter by the aforementioned Arvel Gentry. Since his work is considered the best possible explanation of flow and lift, we will use his diagrams to illustrate what happens. With the mainsail only (see Figure 15.19), the stagnation point (Sm) connects with the sail on the windward side just aft of the mast. With the bulk of the mast in the way, the upwash, i.e., the air that is forced around the front of the foil, has to really speed up to make it around the corner, which now includes the mast. The result is fast-flowing air moving down the backside of the sail that will suddenly have to slow down to meet the Kutta Condition. The rapid slowing will likely result in separation. This is why a mainsail alone is not a very good foil for sailing to windward. I know that there are some yacht designers who believe that a mainsail alone is the way to go, but I have a hard time believing that it's true. Among other things, if this was the case America's Cup yachts could leave their headsails on the dock to save weight, but you don't see them doing that. It's generally accepted that it's important to have a headsail as well, so let's add one now.



Before we look at what happens when both sails are set side by side, we need to take another look at Figure 15.19. Note the streamline passing through a point marked as H. This point is where the headstay is located and gives you a reference point for Figure 15.20. Before the jib is added you can see how much air passes to leeward of the mainsail. Now let's add the jib and take a look at the next diagram. You will see that it is quite cluttered because the diagram attempts to show the old streamlines from Figure 15.19 superimposed over the new streamlines that are created by the addition of the jib. The important thing to note, however, is that a number of changes have taken place. First, the stagnation point of the mainsail has moved. It is no longer found on the windward side of the sail. Instead, it has gone smoothly into the front of the mast and in doing so negates the upwash that was there before. No upwash means that there is no mad scramble of air around the mast and no fast-moving air rushing down the backside of the mainsail. As a result there will be less chance of the air separating from the sail as it slows to meet the Kutta Condition.

The second change that has taken place is that the streamline H that went through the headstay when there was just the mainsail now goes well above the surface of the jib; in fact, it is right at the jib stagnation point. The distance between the two stagnation streamlines (Sm and Sj) is a measure of the amount of air that will now go between the headstay and the mast. The interesting thing to note is now there is much less air flowing between the headstay and the mast than there was when there was just the mainsail alone. The air that might have gone between the two foils has to go somewhere, and it is deflected around the lee side of the headsail. By adding a mainsail we have actually been able to increase the flow of air around the lee side of the headsail thereby creating an even lower pressure.

Figure 15.20

A number of changes have taken place with the addition of the jib. The old streamlines from Figure 15.19 are superimposed over the new streamlines that are now created.

The Slot Effect

The mainsail also creates somewhat of a slot effect at the very *end* of the headsail where the air is squeezed between the leech and the lee of the main. This is not the large slot effect that earlier studies pointed to because the circulation around both sails negates each other to some degree. But the wind does still speed up as much as 30 percent. In fact, studies have shown that the air coming off *both* sides of the headsail has an increased velocity and the Kutta Condition is met not at the free-stream speed, i.e., the speed of the external flow, *but at a faster speed*, again providing even more lift to the overall sailplan. Now isn't that interesting? Who would have thought that the mainsail not only provides some lift of its own, but also makes the headsail more efficient by allowing the jib to operate in its own area of increased wind speed without the danger of violating the Kutta Condition?

All of this goes to show that two sails set properly and working together form a very efficient foil when presented to the wind. They need each other. One sail without the other is like Romeo without Juliet. Okay, that's a bit of a stretch, but you see what I mean. There is a symbiotic relationship between the mainsail and headsail, and even the underwater appendages. If you change one thing, it will have an effect on the other. You need to start thinking of the boat as one whole aerodynamic foil being presented to the wind and water, and not just individual parts.

In their book *The Art and Science of Sails*, Tom Whidden and Michael Levitt sum up this complex area of sails with some very pertinent points about the relationship between mainsail and headsails. There is no way I can put it better or more clearer, so I include it here verbatim for your consideration.

How the Mainsail Affects the Jib

1. The flow ahead of the mainsail causes the stagnation point on the jib to be shifted around toward the windward side of the sail (a lift), and the boat can be pointed closer to the wind without the jib luffing. This lifting shift is called upwash.
2. The leech of the jib is in a high-speed flow region created by the mainsail. The leech velocity on the jib is, therefore, higher than if the jib alone was used.
3. Because of the higher leech velocity, velocities along the entire lee surface of the jib are greatly increased when both the jib and the main are used, and this contributes to the high efficiency of the headsail.
4. The higher lee-surface velocities on the jib mean that the jib can be operated at higher angles of attack (more trim) before the jib lee-side flow will separate and stall.
5. Because of the aforementioned, proper trim and shape of the mainsail significantly affect the efficiency of the overlapping jib. Anything that causes a velocity reduction in the region of the jib's leech, such as some separation on the aft part of the main, results in the jib contributing a lower driving force.

6. The trim of the main significantly affects the pointing ability of the boat, for it directly influences the upwash that approaches the luff of the jib.
7. The drag from the mast – in front of the mainsail – has always been blamed for making the main less efficient than the jib. Another, probably equally important factor, is the increased velocity on the jib and the fact that the Kutta Condition requirement of the jib is satisfied in a local *high-speed* flow region that is created by the mainsail.

How the Jib Affects the Mainsail

1. The jib caused the stagnation point of the mainsail to shift around toward the leading edge of the mast, placing the mainsail in a header. This is downwash.
2. As a result, the peak suction velocities on the forward lee side of the main are greatly reduced. Since the peak suction velocities are reduced, the rise in pressure is less abrupt.
3. Because the speed of the flow is reduced on the mainsail, the possibility of the boundary layer separating and the airfoil stalling is reduced.
4. With the jib up, a mainsail can be operated more efficiently at higher angles of attack (more trim or higher traveler angle) without flow separation and stalling than would be the case with just the mainsail alone. This, too, is caused by a reduction in velocities over the forward-lee part of the mainsail. Since the air is moving fairly slowly at the front, further slowing at the back to satisfy the Kutta Condition is not a dramatic event. This disproves the slot-effect theory. If the air were speeded up in the slot as the old theory promises, the air on the main would be more likely to separate.
5. Much less air goes between the headstay and the mast when the jib is placed in the flow with the main. The circulations of the main and jib tend to oppose and cancel each other in the area between the two sails, and therefore more air is forced over the lee side of the jib.

In Conclusion

At the start of this chapter I pointed out that the wind is invisible to the naked eye, and indeed it is. But it is, however, no longer invisible to the mind's eye, and as a sailor, especially if you are responsible for trimming the sails, being able to "see" the wind will make your job that much easier and that much more enjoyable. Sailors are a unique and individual bunch, probably more so than any group of people. It's what sets us apart and has us interested in a pursuit that is as much mental exercise as it is physical exercise. Sailing is a sport that you either love or dislike – there seems to be very little middle ground. I love it. It has provided me with a living for two and a half decades and is likely to continue to do so. It has also taken me many places I never thought I would go. I have seen remote islands deep in the Southern Ocean and anchored in picture-perfect inlets in the Tropics. I have seen waves crashing over the fore-deck in a hurricane and been witness to a spectacular sunset on a sparkling sea



The Around Alone fleet steams out of Torbay, England, heading for South Africa.

in the middle of an ocean while sailing all alone. I hope that you have learned a few new things by reading this book, and I hope that it makes you a better sailor, and by extension, a better seaman. Now is the time to cast the lines ashore and set sail for the distant horizon. As Mark Twain once said, "Twenty years from now you will be more disappointed by the things you didn't do than by the ones you did do. So throw off the bowlines. Sail away from the safe harbor. Catch the Trade Winds in your sails. Explore. Dream. Discover."

Appendix

It's very important that you supply your sailmaker with as much relevant information as you can before they start the design process. Sails are tailored items, like a new suit, and therefore you need to give the sailmaker as much as possible to work with. The result will be a suit of sails that meets your expectations by not only fitting the rig perfectly, but also performing as designed. Below are key considerations.

Measuring Your Rig

Accurate dimensions are key to getting sails that fit the boat properly and perform as expected. Sailmakers can work from a sailplan if there is one. For new boats this is the only option, but for existing boats it's always better to measure the boat than to scale dimensions off a plan. Details like mast rake, mast bend, and headstay length are critical and unique to each design. Do not measure your old sails. They will likely have stretched over the years and the sizes may not be accurate. You should include any relevant information about the old sails, not just the dimensions. Also indicate if the boat is going to be used for full-on racing, racing/cruising, or cruising alone. If you race make sure that you note which handicap system you compete under. Finally, add as much relevant information as possible. For example, does the boat have running backstays, a babystay, or a hydraulic backstay ram? Is the rig fractional, masthead, or unstayed. This information should already have been communicated to your sailmaker, but it's likely that the point person at the loft will not be the actual sail designer so it's worth duplicating information on the measurement sheet, if only to serve as a reminder.

Here are some tips to consider before taking your measurements:

- Choose a calm day. You will be stringing a tape between two points and wind can bow the tape and falsely increase the dimension.
- Use a steel or fiberglass-reinforced tape, not a cloth tape. (Cloth will stretch when you take long measurements.)
- When measuring things like hoists on headsails, be sure to add a downhaul to the shackle so that you can retrieve the halyard. Relying on the tape is not a good idea. It might break.
- Stretch the tape as tight as you can and take the measurement a few times. Note the average and mark it on the measurement form.
- Take the measurement from the bearing surface of the fitting and do not allow for stretch. Your sailmaker will factor that into his design once the fabric has been chosen.

In general:

- It's better to measure the boat than scale dimensions off a sailplan.
- Do not measure your old sails – they will likely have stretched.
- Include relevant information about your old sails.
- Make note of rigging controls.
- Let the sailmaker know if you are racing, cruising, or a bit of each.

- Take photos of the fittings. When you do this, place a ruler alongside the fittings so that there is a reference point from which to work.
- Write the measurements in pencil. This way if the paper gets wet the ink will not run, and your data will not be lost.

Sailplan Jargon

Most of the names of sail parts have been covered in previous chapters (and they are explained in full in the glossary), but if you look at a sailplan you will see some new and strange letters, namely I, J, P, E, Ii, Ji, Py, Ey, and LP. Let's start by explaining these characters. Note that these are broad explanations only. The exact measurements are quite complicated and not necessary for this discussion.

I – The height of your mast above the deck.

J – The distance from the front of your mast at deck level, to the forestay.

P – The length of the luff of your mainsail or the distance between black bands if you have them.

E – The length of the foot of your mainsail or the distance between black bands if you have them.

Ii – The height of the inner-forestay connection above the deck.

Ji – The distance from the front of your mast at deck level, to the inner-forestay.

Py – The length of the luff of your mizzen or the distance between black bands if you have them.

Ey – The length of the foot of your mizzen or the distance between black bands if you have them.

LP – The “line perpendicular,” the distance from the clew of the sail to the perpendicular, or nearest point, on the luff. (LP is often described as a percentage of J. For example a headsail can be 150 percent, meaning that the LP is 1.5 times the length of the J dimension of the boat. See small diagram on page 269 for an illustration.)

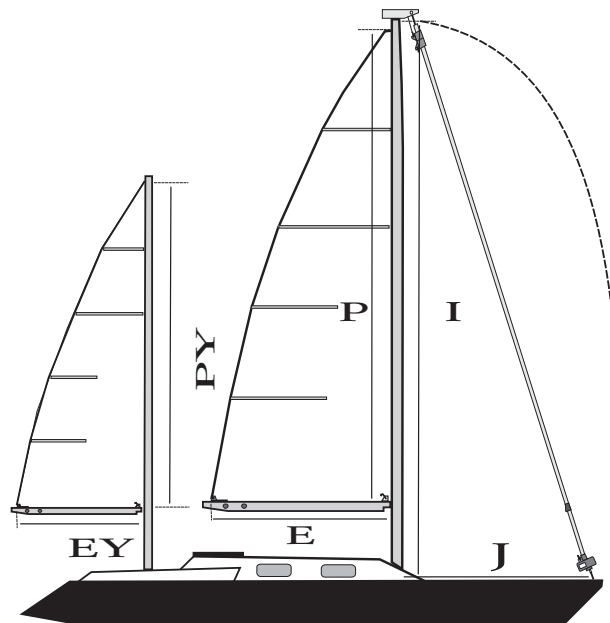

Measuring for a Mainsail

1. **Maximum luff length (P dimension)** – Measure by attaching the tape to the hal-yard shackle and pulling it to the top of the mast until it stops. Secure the hal-yard and measure to the bearing surface of the tack pin. If your mast has black bands, raise the tape until it is just at the lower edge of the band. You will probably have to site the position of the tape from off the boat. Be sure to note that this is a “black band distance” when submitting the data to your sailmaker.
2. **Maximum leech length** – Set your boom at the height and angle you like to have it when the boat is sailing, and using the tape still hoisted to the top of the mast, measure to the bearing surface of the outhaul car with the outhaul fully extended. Be sure to consider any other features on the boat like boom gallows or bimini to make sure that the boom clears them at its lowest point.
3. **Maximum foot length (E dimension)** – Measure from the bearing surface of the tack pin to the bearing surface of the outhaul car with the outhaul fully extended. If there are black bands on the boom measure from the back of the mast to the closest edge of the black band, and be sure to note this when submitting the data.
4. **Distance to the backstay** – With the boom horizontal, measure from the back of the mast to the backstay. This will allow the sailmaker to figure out how much roach he can add to the sail.
5. **Mast rake details** – If you have a retriever line attached to the mainsail hal-yard, tie a plum bob (or any weight) to the end of it and let the line hang straight down to the deck. Measure the distance from the back of the mast to the plum bob. This is the amount of rake in the mast.
6. **Mast bend details** – Take the retriever line and attach it to the gooseneck at the back of the mast. Now sight up the mast. You should be able to estimate how many “mast widths” there are between the line and the back of the mast at its widest point. Measure the fore and aft dimension of the mast and calculate the maximum mast bend. Now, leaving the line attached, walk away from the boat and site the mast bend. Estimate where on the mast the maximum bend falls. This will allow your sailmaker to design the luff of the mainsail to match the pre-bend curve of the mast. Note that you might be able to manipulate this bend with a hydraulic backstay and/or running backstays, however that should not be taken into account at this point. The sailmaker needs the “at-rest” bend.
7. **Spreader heights** – For lower spreaders, toss a line over the spreader and mark where both ends meet the deck. Measure the line and divide it by half to get the spreader height. Once you have the first, and/or maybe second spreader, you can then eyeball the mast from a distance (using a pencil at arm’s length if necessary) and get the best estimate of the height of the rest of the spreaders off the deck.
8. **Spreader widths** – If you know the distance from the base of the mast to the edge of the deck, estimate the spreader lengths by sighting them from afar.

9. **Spreader angles** – Match the shroud base with the base of the mast and extrapolate it up the rig. These spreader dimensions are important to the sailmaker. If your mainsail is to have full-length battens, the sail designers must ensure that he does not design the sail with a batten that falls right at the spreader tip, both when fully hoisted and when reefed. By noting the spreader angle and length the sail designer will be able to reinforce the sail with spreader patches, although it's often best to wait until the sail is on the mast before marking for spreader patches.
10. **Mast crane** – Using the width of the mast as a gauge, estimate the distance the masthead crane extends beyond the back of the mast. This will let the sailmaker know what size of headboard he can have on the sail.
11. **Outhaul track** – Measure the length of your outhaul track.
12. **Outhaul attachment** – Measure the jaw width of the shackle on the outhaul car if there is one. This way the sailmaker can be sure that the shackle at the clew fits over the ring in the sail.
13. **Clew set-up** – Measure from the top of the boom to the bearing surface of the pin of the outhaul car. This is only necessary if the foot of the sail goes into a bolt rope slot or track on the boom; if the sail is loose footed, the set-up does not make a difference.
14. **Tack set-back** – Measure from the back of the mast to the bearing surface of the tack pin. This will allow the sailmaker to set back the tack of the sail below the first slide or bolt rope slot so that there will not be any wrinkles in the corner of the sail.
15. **Tack set-up** – Measure from the top of the boom to the bearing surface of the tack pin. This is only necessary if the foot of the sail goes into a bolt rope slot or track on the boom. If the sail is loose footed, the set-up does not make a difference.
16. **Reef hook set-back** – Measure from the back of the mast to the bearing surface of the reef hook. This will allow the sailmaker to ensure that the reef point is located in the correct place in the sail so that there will not be any wrinkles out of the clew of the sail when it is reefed.
17. **Reef hook set-up** – Measure from the top of the boom to the bearing surface of the reef hook. This will ensure that the boom is at the correct angle when the sail is reefed.
18. **Feeder height** – Measure from the top of the boom to the luff groove exit or the slide stop.
19. **Boom track details (front end)** – Measure from the back of the mast to the front of the bolt rope groove or track on the boom. This will ensure that the slides or bolt rope fit the boom.

Mainsail Measurement Sheet

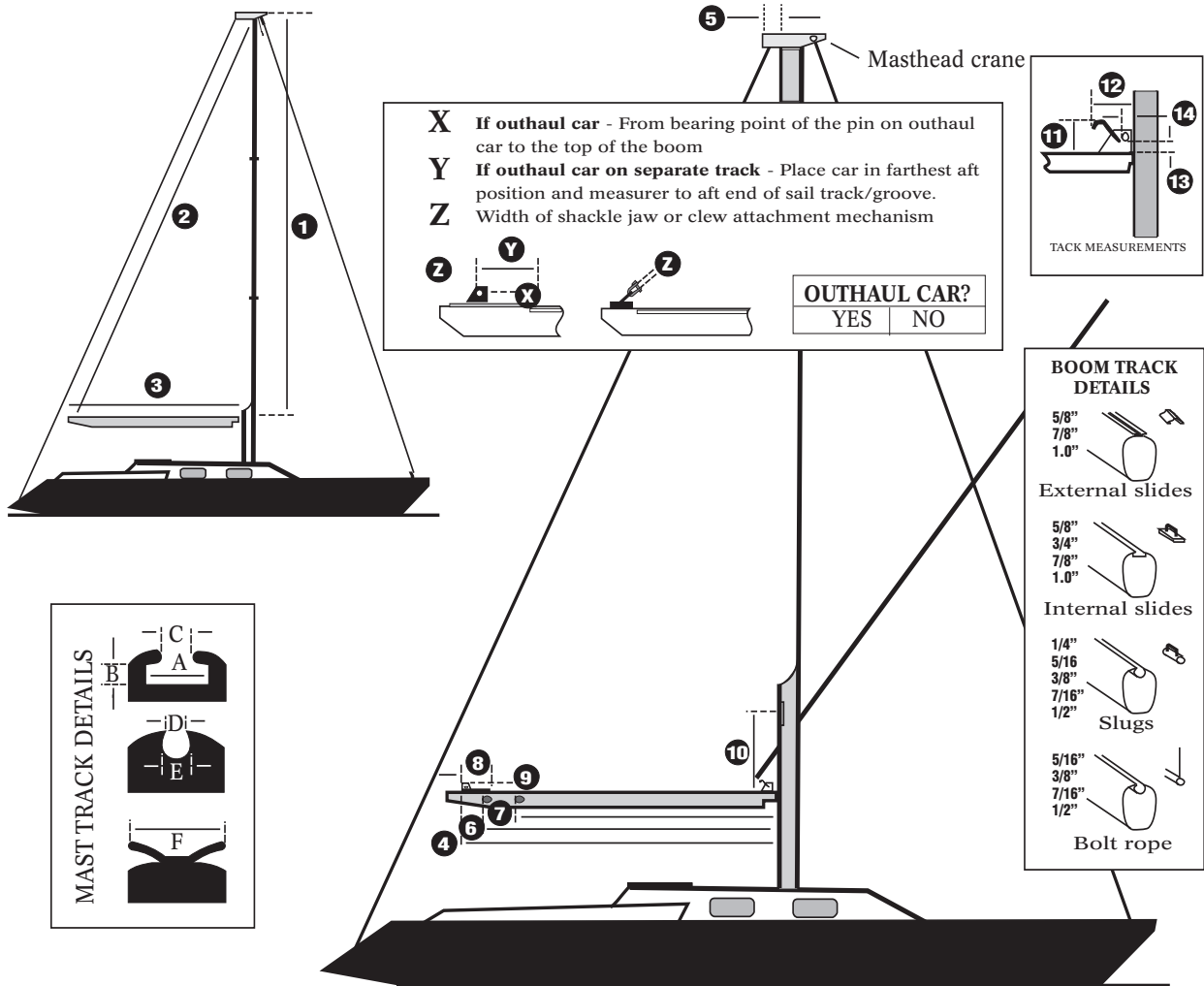

MEASURING TIPS. CHOOSE A CALM DAY IF POSSIBLE. STRETCH YOUR TAPE MEASURE AS TIGHT AS YOU CAN AND TAKE THE MEASUREMENT. IF NECESSARY MEASURE A FEW TIMES AND SEND US THE AVERAGE. DO NOT ALLOW FOR STRETCH, WE'LL DO THAT.

- 1 P DIMENSION (max luff) hoist the halyard until it stops (to the sheave) – measure from that point to the top of the boom
- 2 MAX LEECH with the halyard at max hoist, measure to the top of the boom outhaul car*
- 3 BACKSTAY with the boom horizontal, measure from the back of the mast to the backstay
- 4 E DIMENSION (max foot) measure from the back of the mast to the clew attachment at its furthest aft location
- 5 MAST CRANE estimate the length of your mast crane – back of mast to end of crane
- 6 REEF SHEAVE measure from the back of the mast to the bearing surface of your first reef sheave**
- 7 REEF SHEAVE measure from the back of the mast to the bearing surface of your second reef sheave**
- 8 OUTHAUL measure the length of your outhaul track (see X, Y, Z diagram above)
- 9 CLEW SET UP measure from the top of the boom to the bearing surface of the pin in the outhaul car
- 10 FEEDER HT measure from the top of the boom to feeder on the back of your mast
- 11 REEF HOOK HT measure from the top of the boom to the bearing surface of the reef hook
- 12 RH SET BACK measure from the back of the mast to the bearing surface of the reef hook
- 13 TACK SET UP measure from the top of the boom to the bearing surface of the tack pin
- 14 TACK SET BACK measure from the back of the mast to the bearing surface of the tack pin

MAST TRACK DETAILS measure your track per the diagram

BOOM TRACK DETAILS measure your track per the diagram or discuss a loose-footed mainsail with your consultant

*you need to set your boom in a position so that it clears a bimini or boom gallows, and then measure it.

** if you don't have reef sheaves, please indicate what you have for reefing and give us the measurements.

- 20. Boom track details (back end)** – Measure from the back of the mast to the end of the bolt rope groove or track on the boom. This will ensure that the slides or bolt rope fit the boom.
- 21. Reef sheave** – Measure from the back of the mast to the bearing surface of each of the reef sheaves. This way the sailmaker can be sure he places the reef points in the sail where they will correspond with the reef sheaves. If the sheaves are on a track, indicate the length of track and measure to the front end of each. If your boom is not equipped with reef sheaves, indicate what there is on the boom for reefing, and let your sailmaker know together with pertinent measurements.
- 22. Mast track details** – Look at the diagrams on the measurement forms, match the kind of mast track to the one you have on your boat, and indicate the size.
- 23. Boom track details** – Look at the diagrams on the measurement forms, match the kind of boom track you have on your boat, and indicate which size is correct.

Measuring for a Headsail

- 1. Height of I** – If you do not have a sailplan and would like to know your I dimension, attach a tape measure to your Genoa halyard and hoist the halyard to the top of the mast. Be sure to attach a retrieval line so that you do not have to rely on the tape for pulling the halyard back down again. Now measure to the base of the mast for your I dimension. This is an estimated I dimension. The lower point of I is relative to the height of your freeboard and some other factors, but for a sailmaker's purpose this is sufficient.
- 2. Max luff length** – With the tape still at the top of the mast at a full-hoist position, measure to the bearing surface of the tack attachment of the sail. This dimension is for a sail that is going to be attached with hanks. If there is going to be a furling unit on the stay, attach the tape measure to the masthead swivel, hoist it as high up the forestay as it can go, and measure to the bearing surface of the shackle on the furling drum.
- 3. Drum height** – This measurement lets the sailmaker know how high the furling drum is off the deck so that he can calculate where the sail will sheet to be sure that it hits the track on the deck. Measure from the bearing surface of the tack shackle to the center of the forestay pin. Measure in stages: first to the top of the drum, then the height of the drum, and finally to the forestay pin.
- 4. Height of Forestay Pin** – Include the height of the forestay pin by measuring from the center of the forestay pin to the deck.
- 5. Furling Swivel** – Note that if you have provided the max luff length and drum height, this dimension will not be absolutely necessary, but it's always important to give your sailmaker as much information as possible. Measure from the bearing surface of the halyard attachment to the bearing surface of the sail attachment.

Headsail Measurement Sheet

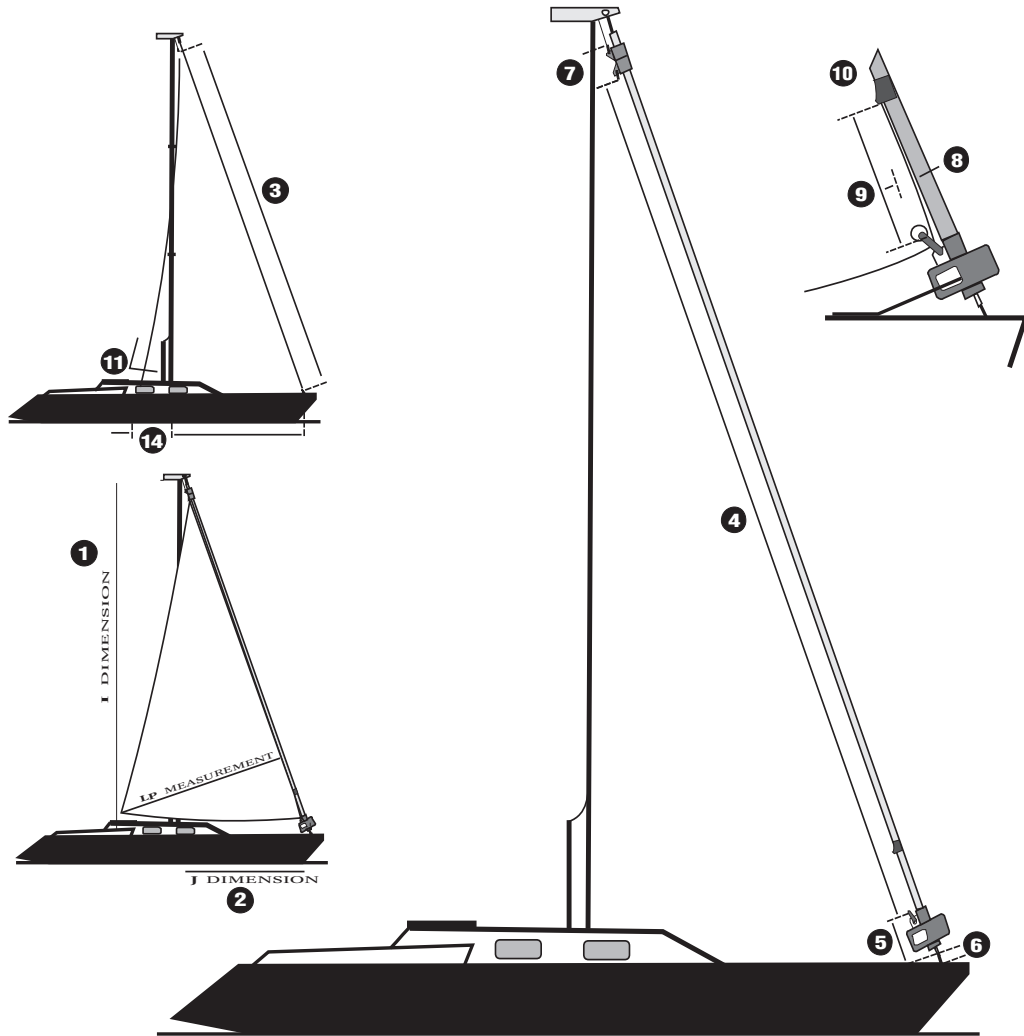

MEASURING TIPS. CHOOSE A CALM DAY IF POSSIBLE. STRETCH YOUR TAPE MEASURE AS TIGHT AS YOU CAN AND TAKE THE MEASUREMENT. IF NECESSARY MEASURE A FEW TIMES AND SEND US THE AVERAGE. DO NOT ALLOW FOR STRETCH, WE'LL DO THAT

1	I DIMENSION	measure from the intersection of the forestay and the mast down to the deck	-----	<input type="text"/>
2	J DIMENSION	measure from the forestay attachment point at the deck to the front of the mast	-----	<input type="text"/>
3	MAX LUFF (no furling)	measure from the halyard attachment to the bearing surface of the tack attachment (for hanks)	-----	<input type="text"/>
4	MAX LUFF (for furling)	measure from the bearing surface of the swivel shackle, to the bearing surface of the drum shackle	-----	<input type="text"/>
5	DRUM HEIGHT	measure from the bearing surface of the shackle to the center of the forestay pin	-----	<input type="text"/>
6	FORESTAY PIN	measure from the center of the forestay pin to the deck	-----	<input type="text"/>
7	FURLING SWIVEL	measure from the bearing surface of the halyard attachment to the bearing surface of the sail attachment	-----	<input type="text"/>
8	TACK SETBACK	measure from the back side of the foil to the bearing surface of the tack shackle	-----	<input type="text"/>
9	FEEDER HEIGHT	measure from the headsail tack attachment point to the bottom of the feeder	-----	<input type="text"/>
10	LUFF TAPE SIZE	what kind of furling unit do you have, or do you have hanks?	-----	<input type="text"/>
11	CLEW HEIGHT	what is your preferred clew height (low at lifeline height, or higher near boom height?)	-----	<input type="text"/>
12	TRACK POSITION	measure from the forestay attachment point at the deck to the front of the Genoa track	---	<input type="text"/>
13	TRACK POSITION	measure from the swivel shackle (or halyard for hank-on) to the front of the Genoa track*	---	<input type="text"/>
14	TRACK LENGTH	measure the length of your track	-----	<input type="text"/>
15	TRACK POSITION	measure from the centerline of the boat to the track	-----	<input type="text"/>
	MISC DETAILS	what color sunshield do you want? Which side of the sail do you want it on?		

* pass the tape around the outside of the shrouds as the leech of the sail would.

6. **Tack set-back** – Measure the tack set-back from the aft side of the foil to the bearing surface of the tack swivel. This ensures that there will not be any hard spots up the luff of the sail.
7. **Feeder heigh** – Measure from the bearing surface of the shackle on the furling drum to the bottom of the feeder.
8. **Track position (fore and aft)** – Measure from the forestay attachment point at the deck, to the front of the Genoa track.
9. **Track position (athwartships)** – Measure from the centerline of the boat to the track. If the track does not run parallel to the centerline, provide a measurement from the centerline to the front of the track and one from the centerline to the back of the track.
10. **Track length** – Measure the length of the Genoa track.
11. **Spreader details** – Use the same techniques described in “mainsail measurements” to get height, length, and angle of the spreaders.
12. **Track position relative to the hoist (optional)** – Measure from the maximum hoist point to both the forward and aft ends of the track. If you are measuring for a blade jib do not take the rig into account. For a Genoa, pass the tape around the outside of the shrouds as if it were the leech of the sail. Modern sail design programs allow the sail designer to enter data about the spreaders and design the sail taking them into account, but providing this dimension is one more cross-reference point for the sailmaker.
13. **Height of stanchions** – Measure from the base of the stanchion to the top. This is useful for the sailmaker to know when it comes to placing the height of the clew. If the sail will be barber-hauled out to the rail, the height of the clew should clear the lifelines.

Miscellaneous

1. Be sure to provide your sailmaker with the make and model of your furling unit so that they can match the luff tape on the sail.
2. Note the color of the sunshield if your headsail is to have one.
3. Indicate the height you would like the clew of the sail.
4. Provide tack attachment details if it is not a conventional system.

Glossary

- toward the rear of the boat.
- a piece of rigging used when flying a spinnaker. Also called a brace, the after-guy attaches to the windward clew of the spinnaker.
- the middle of the boat.
- the wind that is felt by a moving boat rather than the actual wind that is blowing. If the boat is sailing toward the wind, the apparent wind increases. If the boat is sailing away from the wind, the apparent wind decreases.
- the angle at which wind blows across the deck of a boat when it is sailing. If it is sailing toward the wind, the apparent wind angle is less than the actual (or true) wind angle. If a boat is sailing away from the wind the apparent wind angle is greater than the true wind angle.
- the luff length of a sail divided by the foot length.
- air that is passing over the surface of the sail that is affected by the surface friction of the sail.
- a piece of rigging that runs from the back of the boat to the top of the mast; it may be adjustable in order to bend the mast or increase tension on the headstay.
- a line attached to the headsail used to adjust the angle of the sail athwartships.
- thin, stiff strips of plastic, wood, or composite material placed in pockets along the leech of the sail to support the back end.
- the widest part of the boat.
- a point of sail where the boat is sailing at right angles to the wind.
- a point of sail where the boat is sailing close hauled.
- diagonally across a piece of fabric at 45 degrees to the warp and fill.
- a rope sewn into the luff of a sail used for attaching it to the mast or furling unit.
- a spar to which the mainsail's lower edge is attached.

A

Aft

Afterguy

Amidships

Apparent wind

Apparent wind angle

Aspect ratio

Attached flow

B

Backstay

Barber hauler

Battens

Beam

Beam reach

Beating

Bias

Bolt rope

Boom

Boom vang	– a system used to hold the boom down, particularly when the boat is sailing downwind.
Bow	– the front of the boat.
Bowman	– the crewmember in charge of sail changes and keeping a lookout on the bow at race starts.
Bowsprit	– a short spar extending forward of the bow used for setting asymmetrical spinnakers.
Broach	– what happens when the boat gets overpowered by the wind while sailing with a spinnaker.
Broad reach	– a point of sail where the boat is sailing away from the wind, but not directly downwind.
C	
Camber	– the curved shape of a sail.
Catenary	– load lines.
Chainplates	– metal or composite plates that attach the standing rigging to the boat.
Chord	– a chord is determined by running an imaginary line from the luff to the leech of a sail and measuring the distance from this line to the deepest part of the sail.
Chord depth ratio	– the ratio between the depth of the chord and the length of the chord. The lower the chord depth ratio, the fuller the sail and vice versa.
Chute	– another name for a spinnaker.
Close hauled	– a point of sail where the boat is sailing as close to the wind as it can.
Close reach	– a point of sail where the boat is sailing toward the wind, but not as close as close hauled.
Cleat	– a piece of equipment that holds a line against the tension from the sails, rigging, or mooring.
Clew	– the lower corner of a sail where the sheet is attached.
Code 0	– a flat spinnaker used for sailing very close to the wind.

– the number of fibers per inch in the warp or fill of a fabric.	Count
– the direction a yacht is sailing.	Course
– permanent, continuous elongation of a fiber under sustained load.	Creep
– the team of sailors that are sailing the yacht.	Crew
– what occurs during the weaving process when the warp yarns are forced over and under the fill yarns. Crimp contributes to the elongation of a fabric under load.	Crimp
– a sail panel configuration where the seams run parallel to one another perpendicular to the leech.	Cross-cut
– a control device for the sail used to move the location of maximum draft in the sail.	Cunningham
	D
– a white, woven fabric made of polyester. Dacron is the trade name give by Du Pont.	Dacron
– sailing with the wind directly from behind.	Dead downwind
– a measure of the weight of a continuous fiber filament. It is the weight in grams of 9,000 meters of a given fiber. The lower the number, the finer the fiber.	Denier
– a measure of a fabric’s relative weight and strength expressed as the number of fibers per inch generally in the primary yarn direction.	Denier per inch (DPI)
– the point of sail when the wind blows from aft of the boat’s beam.	Downwind
– the depth of a boat at its lowest point. Also the depth or fullness of a sail.	Draft
	E
– to loosen or let out a sail.	Ease
– the difference between the initial length of a fabric sample and its length after stretching.	Elongation
	F
– the basic filament that is twisted into a yarn used to make fabric.	Fiber
– a single fibril of natural or synthetic textile fiber. Filaments are twisted or bunched to form fibers.	Filament

Fill	– the fibers in a fabric that run across a roll of cloth.
Fill orientated	– a fabric that has its principal strength running in the fill direction.
Film	– an extruded sheet of plastic, most often Mylar polyester film used in laminate sailcloth to control bias stretching.
Flattening reef	– a reef point found on the leech of a mainsail used to remove shape from the sail.
Flex strength	– the ability of a fiber to retain its strength after being folded back and forth.
Foot	– the bottom edge of a sail.
Foot shelf	– an elliptical or lens-shaped piece of fabric attached to the foot of a mailsail.
Foredeck	– the area of the yacht’s deck in front of the mast.
Foreguy	– a line used to control the outboard end of a spinnaker pole to stop it from rising up.
Foresail	– another name for a headsail.
Forestay	– another name for a headstay.
Form drag	– the drag that occurs when any object presents a surface to the movement of air.
Fractional rig	– a rig where the headstay does not go all the way to the top of the mast.
Frictional drag	– the amount of friction between any surface and the surrounding air.
Furl	– to fold or roll a sail away.
G	
Gennaker	– a cross between a Genoa and a spinnaker.
Genoa	– a large foresail that overlaps the shroud base used for sailing upwind.
Gooseneck	– the mechanical device that connects the boom to the mast.
Gybe	– see jibe.
H	
Halyard	– a line used to hoist and hold up the sail.
Hand	– the softness or firmness of a fabric.

– the top of a sail.	Head
– a wind shift during which the wind enters the boat further forward.	Header
– a sail flown between the mast and headstay (same as foresail).	Headsail
– a piece of standing rigging used to support the mast running from the bow of the boat or the bowsprit, to the top of the mast.	Headstay
– the steering station of the yacht.	Helm
– the person who steers the yacht.	Helmsman
– the attachment points for the shrouds up the mast.	Hounds
– the body of a yacht.	Hull
– the drag that occurs when air from the windward side of a sail tries to push up and over, or down and under a sail to get to the leeward side, i.e., air traveling from an area of high pressure to an area of low pressure.	I Induced drag
– a headsail that fits between the headstay and the mast.	J Jib
– the process of turning the yacht so that the stern goes through the eye of the wind thereby changing the side of the boat on which the sails are carried.	Jibe
– a ballasted appendage projecting from below the boat that keeps it from capsizing.	K Keel
– a low-stretch gold aramid fiber that is used to make sails.	Kevlar
– fabric constructed from layers of film, scrim and/or taffetas glued together under high pressure and/or heat to form a composite sail material.	L Laminate
– the afterguy on the leeward side that is not being used while a spinnaker is flying.	Lazy guy
– light lines run from the mast to points on the boom that form a cradle into which the mainsail can be lowered.	Lazy jack
– the front edge of a sail.	Leading edge
– the trailing edge or back edge of the sail.	Leech

Leechline	– a light line that runs in a pocket up the leech of a sail to stop the edge from fluttering.
Leeward	– away from the wind or downwind.
Lift	– a wind shift during which the wind enters the boat from further aft. It allows the helmsman to head up or alter course to windward, or the crew to ease the sheets.
Line	– any piece of the boat’s running rigging that is used to manage and trim the sails.
Luff	– the leading edge of a sail. Also means to change course toward the wind.
M	
Mainsheet	– the line that controls the boom and by extension the mainsail.
Mast	– a vertical spar to which sails are attached.
Masthead rig	– a design in which the headstay runs all the way to the top of the mast.
Maximum draft	– the deepest part of a sail measured across the sail from luff to leech.
Modulus	– a measure of a material’s ability to resist stretch. Initial modulus is usually expressed as grams of load per unit stretch for a certain fiber denier. The higher the initial modulus, the less the fiber will stretch.
O	
Off the wind	– sailing away from the wind (downwind).
Outhaul	– the line that adjusts the tension of the foot of a mainsail along the boom.
P	
Pinch	– to sail as close to the wind as possible.
Pole guy	– a separate line that runs from the outboard end of a spinnaker pole to the deck, used to keep the pole in place.
Port	– the nautical term for the left side of the boat.
Port tack	– sailing with the wind blowing from the port side of the boat, so the sails will be set on the starboard side.
R	
Radial	– a panel layout where the seams and panels radiate out from the corners of the sail.
Rake	– the fore or aft angle of the mast.

- when the boat is sailing from the beam. A reach can be anywhere from just aft of sailing close hauled to just forward of sailing dead downwind.
- to reduce the size of a sail.
- the general term used to describe the yacht’s mast and sail combination.
- the wires, lines, halyards and other items used to attach the sails and spars to the boat. The lines that do not need to be adjusted are known as standing rigging. Those lines that are adjustable are known as running rigging.
- the back end of a mainsail that projects beyond a straight line between the head and clew. The roach is supported by battens.
- sailing with the wind from behind the boat.
- a loose knit of yarns used in laminated sailcloth.
- a line that controls the sails and adjusts their angle relative to the wind.
- a cable or rod that supports the side of the mast running from the side deck to the top of the mast (or where the headstay attaches in the case of a fractional rig).
- a large balloon type sail that flies out front of the boat when the wind is from behind.
- a pole that is attached to the lower front of the mast to hold one corner of the spinnaker out from the yacht.
- vertical poles that run along the outer edge of the deck to hold the lifelines.
- the non-moving rods and lines that support the mast and sails.
- the nautical term for the right side of the yacht.
- sailing with the wind blowing from the starboard side of the boat, so the sails will be set on the port side of the boat.
- a rod or wire that supports the mast in the fore/aft position.
- a small sail set between the mast and the inner forestay.
- a short strip of leather; a strap.

Reaching**Reef****Rig****Rigging****Roach****Running****S****Scrim****Sheet****Shroud****Spinnaker****Spinnaker pole****Stanchions****Standing rigging****Starboard****Starboard tack****Stay****Staysail****Strop**

T

Tack – the lower forward corner of a sail where it attaches to the yacht; also means to alter direction of the boat with the bow passing through the eye of the wind.

Taffeta – an unfinished fabric employed as a covering, usually in a laminate sailcloth, to enhance durability and chafe resistance.

Telltails – light pieces of yarn or strips of nylon that are attached to the front of a headsail and the back of a mainsail that show how the wind is flowing across the sail.

Tenacity – relates to the breaking strength of fibers.

Tensile strength – a measure of the ability of a yarn, fiber, or fabric to withstand pulling stresses.

Threadline – the direction of the fibers or yarns in the warp, fill, or bias.

Topping lift – a line that holds up the boom when it is not being used. Also the line that controls the height of the outboard end of the spinnaker pole.

Traveler – a fitting across the boat to which sheets are led allowing the mainsail to be moved from side to side while still maintaining the same tension on the leech of the sail.

Trim – to adjust the sails to get the right shape.

Trysail – a small ruggedly built sail flown aft of the mast during storm conditions used to balance the boat in place of the mainsail.

Tweakers – light block and tackle used to adjust the sheeting angle of headsails and spinnakers.

Twist – turning of the wind direction caused by air particles close to the surface of the water being slowed by friction.

U

Upwind – sailing close to the wind.

UV resistance – UV resistance is expressed as the time it would take for a material exposed to sunlight to lose half of its strength.

W

Warp – the yarns of fibers in a fabric that run the length of a roll of cloth.

Warp orientated – a fabric that has its principal strength running in the warp direction.

- the force a helmsman feels when the pressure of the wind on the sails is trying to force the bow of the boat toward the direction of the wind.
- a device used to give a mechanical advantage when hauling the lines.
- against the wind.

- a continuous strand of fibers created when a cluster of individual fibers or filaments are twisted together. Yarns are used to create sail fabrics.

Weather helm

Winch

Windward

Y

Yarn

DETAILED TABLE OF CONTENTS

How to get the most from this book x

Introduction 1

Chapter 1: A TRIP TO THE SAILMAKERS 5

A hypothetical look at buying sails

Chapter 2: IT STARTS WITH A YARN 13

A look at all the fibers used to make sails

Tensile Strength, Modulus, Tenacity, Creep, Flex, UV Resistance 14

The Originals: Flax and Cotton, *Sidebar – From Flax to Cotton* 14

Benchmark Fibers: Dacron/Polyester, Nylon 15

Polyethelenes: Pentex, Spectra, Dyneema, and Certran 17

Aramid: Kevlar, Technora, Twaron,

Sidebar – Thank Goodness for Ted Hood 19

Liquid Crystal Polymers: Vectran, PBO, Carbon Fiber,

Sidebar – Vectran for the Defense Industry 22

A Final Word on Yarns 23

Chapter 3: FROM THREAD TO FINISHED FABRIC 25

How sailcloth is made

Woven Fabrics: Warp and Fill, Denier Per Inch, The Loom, Bias Stretch,

Crimp, Heat Setting, Fillers, Finishing, Calendering, Stable Fabrics at Last 26

An Effort to Improve Dacron 33

Other Characteristics of Good Sailcloth: Fabric Strength, Tear Strength

Abrasion Resistance, Ultraviolet Degradation, Water Absorption,

Fabric Smoothness 34

Factors That Affect the Price of Dacron Sailcloth: Yarn quality, Yarn content,

Tightness of the weave, Types of finishes 36

A Final Word About Woven Fabrics 37

Laminated Fabrics: Parts of a Laminate, Some Background,

Sidebar – Who Says Sails Don't Stretch?, The Laminating Process,

The Magic of Films, A Closer Look at Film Choices,

What About Shrinkage?, Scrim, Diagonal Yarns 37

Laminated Sails in Depth 43

Laminate Styles: **Type 1:** Woven/Film, **Type 2:** Film/Scrim/Film,

Type 3: Woven/Film/Scrim/Film/Woven, **Type 4:** Woven/Scrim/Woven, 43

Case Study – Fabric for High Latitude Sailing 45

Where to Now? 47

What is Cuben Fiber? 47

The History of Cuben Fiber 48

Making Cuben Fiber 49

Is Cuben Fiber Cost Effective? 50

Chapter 4: A PRIMER OF PANEL LAYOUTS 51**Different layouts for different fabrics**

- Finite Element Analysis 51
- Mitre- and Cross-Cut Sails 54
- A Case for Multiple Plies 56
- Crescent-Cut and Saw-Tooth Sails 57
- Radial Sails 59
- Mainsails and Bi-Radial Sails 61
- Aligning Fabric Along Load Lines 63
- Asking Good Questions 63
- A New Generation of Sailmaking 64

Chapter 5: MOLDED SAILS 65**The latest sailmaking technologies**

- What Are Molded Sails? 65
- An Uncertain Beginning 66
- Genesis 67
- 3DL: *Sidebar – The 3DL Story* 69
- Building a 3DL Sail: **Step 1:** Sail Design, **Step 2:** Laying Fibers,
Step 3: Adding a Scrim, **Step 4:** Heating and Curing, **Step 5:** Finishing 70
- Continuing Improvements to 3DL: Moisture Absorption, Adhesive Technology,
Head Pressure, Adding Durability 72
- Tape Drive 74
- D4 75
- Case Study – Transatlantic Race 75
- Other Advantages of Molded Sails 78

Chapter 6: WHERE ART AND SCIENCE MEET 79**A look at the sailmaking process**

- The Design Process – Turning Theory and Fabric Into Flying Shapes:
 - Chord Depth or Sail Draft, Twist, Vertical Distribution of Depth,
Induced Drag, Leading Edge Angle, Luff Curve 80
- Sail Design 101 87
- Loads – Catenary Versus Isotropic:
 - Step 1:** Geometry; **Step 2:** Sail Shape, Molded Shape, Flying Shape;
Step 3: Analysis; *Sidebar – Wind tunnels versus computer programs* 87
- The Manufacturing Process – Turning the Design Into a Sail 90
- The Five Steps to Making Sails: **Step 1:** First Layout,
Step 2: Broadseaming and sewing, **Step 3:** Second Layout,
Step 4: Finishing, **Step 5:** Handwork 91
- Sailmaking Today: Nesting the Design 94

Chapter 7: THE DEVIL IS IN THE DETAILS 97

A close-up look at the individual parts of a sail

Fabric and Engineering Considerations for Cruisers 97

Fabric and Engineering Considerations for Racers 99

Mainsail Details for the Cruising Sailor: The Cunningham, Foot Shelf, The Flattening Reef, Edge Treatment, Leechlines, Reefs, Battens 99

In-Mast Furling Mainsails: *Sidebar—Hand Cranking Across the Atlantic*, Gaining Performance From an In-Mast Furling Mainsail: Vertical battens, Swing battens, Inflatable battens 106

In-Boom Furling Mainsail: *Sidebar – My First Introduction to In-Boom Furling* 110

Engineering Details for In-Boom Furling Mainsails: Fabric, Leech Plies, Luff Tape, Luff Curve, Full-length Battens, Reef Locations, Sail Profile, No Hardware, Installation and Handling 111

A Guide for In-Boom Furling Systems: *Sidebar – A Personal Perspective* 114

Alternative Mainsail Handling Systems: Lazy Jacks, Stackpack, The Dutchman 115

Headsails for the Cruising Sailor: Hanks for Headsails, *Sidebar—To Furl or Not to Furl?* 117

Sail Engineering for Roller-Furling Headsails: Foam Luff Pad, UV Sunshield, Overhead Leechline, Extended Head and Clew Patches, Reef Reference Points, Hank Reinforcement, Trim Stripe, Telltales 119

Gaining Performance From Your Furling Headsail 122

A New Generation of Furling Headsails 124

Chapter 8: ALL ABOUT SPINNAKERS 125

Downwind sails explained

A Brief History 125

Different Panel Configurations 126

Spinnaker Fabrics 129

Symmetrical Versus Asymmetrical Spinnakers 130

Spinnakers for the Cruising Sailor 131

The Theory 132

Using Symmetrical and Asymmetrical Spinnakers 133

Spinnakers by the Numbers: Code 0, Code 1, Code 2, Code 3, Code 4, Code 5 135

Chapter 9: STORM SAILS 139

Techniques, Tips and Some Lessons Learned

The Storm Jib: Gale Sail, *Sidebar – Snapped Furling Lline* 139

The Storm Trysail: A Separate Trysail Track 142

Carry Out a Dry Run, *Sidebar – 1979 Fastnet Race* 143

Other Factors to Consider When Setting Storm Sails 145

Storm Preparation 146

Chapter 10: SAIL INVENTORIES 147**A look at what sails you need for your sailing purposes****The Working Staysail:** *Sidebar – A Trusted Ally* 147**Mizzens** 149**Mizzen Staysails** 149**Daisy Staysail** 150**Categories of Sailors:** Grand Prix Racing, Weekend Warrior, Club Racers, Performance Cruisers, Traditional Sailors 151**Sail Inventories:** A Basic Sail Inventory, Additional Sails, Offshore Cruisers Inventory 155**Determining the Number of Reefs in the Mainsail** 156**Final Thoughts** 156**Chapter 11: THE FINE ART OF SAIL TRIM** 157**How to get the most from your sails****About Telltales:** Installing Telltales 158**Mainsail Controls for Performance:** The Mainsheet, Mainsail Traveler, Vang, Backstay, Running Backstays, Halyard Tension and Cunningham, Outhaul, Flattening Reef 159**Headsail Controls for Performance:** Backstay, Halyard Tension and Cunningham, Sheet Position 166**Windward Sail Trim:** Basic Rules 168**The Importance of the Draft Location** 171**Trimming for Different Conditions:** Calm (under 5 knots), Very light air (4 to 6 knots), Light air (6 to 10 knots), Moderate air (8 to 15 knots), Moderate to strong air (15 to 25 knots), Strong air (above 25 knots) 172**Sail Trim on Other Points of Sail:** Bearing Away Onto a Reach/Headsails, Mainsail Control on a Reach 179**Downwind Sailing** 180**Control Lines for Downwind Sailing:** Afterguy, Spinnaker Sheet, Topping Lift, Downhaul or Foreguy 181**Spinnaker Trim:** Manipulating Spinnaker Shape, Changing Chord Depth, Raising or Lowering the Pole, Manipulating the Draft, The Angle of the Spinnaker Pole 182**Spinnaker Handling in Heavy Winds** 184**Advanced Sail Trim for Racers:** Pre-Start, Windward Leg, Finding Speed, Gaining Height, Fine-Tuning for Waves, The Downwind Leg 186**In Summary** 189**Chapter 12: SAIL HANDLING** 191**Techniques for Managing the Unmanageable****Spinnaker Handling Techniques for Cruisers:** Stopping a Spinnaker: Using bands as stops, Using yarns as stops; The Spinnaker Sock; The Dousing Sock; *Sidebar – The History of the Spinnaker Sleeve;*

The Spinnaker Turtle; Setting a Spinnaker; Setting an Asymmetrical Spinnaker; The Tacker; Dousing the Spinnaker; Tips for Using a Dousing Sock; Spinnaker Trip Mechanism for Easy Takedowns 191

Spinnaker Handling Techniques for Racers: The Bear-Away Set; The Jibe-Set; Perfecting the Jibe: Light winds, Moderate winds, Heavy winds; Jibing an Asymmetrical Spinnaker; Without a spinnaker pole; With a spinnaker pole 201

What to do When it all Goes Wrong 208

Spinnaker Takedown: The Windward Takedown, The Leeward Takedown 209

Handling Your Working Sails: Tacking, Changing Headsails, Flaking a Headsail, Furling or Reefing a Headsail, Reefing a Mainsail, Unreefing a Mainsail 212

Chapter 13: A STITCH IN TIME 217

Sail care and repair

Sail Care: Flogging, Sunlight, Chafe, Using a Sail Beyond Its Designed Wind Range, Moisture and Mildew 217

Sail Repair: Sticky-Back Dacron, Patching, *Sidebar – Sail Repair at Sea*, Sail Repair Kit, 221

Determine the Condition of Your Sails: Check Fabric, Check Seams, Check Hardware, Look for Chafe, Replace UV Protection, Maintaining Your Investment 226

Chapter 14: MORE QUESTIONS THAN ANSWERS 229

A conversation with your sailmaker

Is polyester only used to make cross-cut sails? 229

Is there a limit to the size of boat that can have Dacron sails? 229

Nylon has some give to it. Is that good for spinnakers? 229

Pentex is also a polyester: How is it that Pentex sails perform better than regular Dacron? 230

What are the attributes and drawbacks of Spectra? 230

Why would you not use Kevlar for cruising sails? 230

What about Vectran? Where does this fiber fit in? 230

Is there a future for PBO in sailmaking? 230

And carbon. Does it have a future? 230

Can woven fabrics be laminated? 231

What are the differences between fill-orientated fabrics, warp-orientated fabrics, and balanced fabrics? 231

What does heat setting do to a woven polyester fabric? 231

What are the drawbacks of fillers in woven polyester fabrics? 231

What does the calender do? 232

What are some of the things to look for in a good Dacron? 232

On a laminated fabric, what do the taffetas do? 232

How does Cuben Fiber differ from ordinary laminated fabrics? 232

Can I have Cuben Fiber sails for my boat? 232

Can you explain why sailmakers started to ply sails?	232
What are the advantages of radial sails?	233
When would one consider a bi-radial mainsail?	233
What are the disadvantages of radial sails?	233
When would you need a tri-radial headsail?	233
Can you define what you mean by a molded sail?	233
Can you define the difference between a filament and a fiber or yarn?	233
Are molded sails as durable as paneled sails?	234
Define chord depth and explain how it relates to sail design.	234
Why is there twist built into sails?	234
Please explain induced drag.	234
What can be done to minimize induced drag?	234
How important is the luff curve?	234
Can you describe the difference between molded shape and flying shape?	235
Can you explain how shape is added to flat panels of fabric?	235
Why does the weight of sails matter?	235
How do I know how many reefs I need?	235
Can you explain the pros and cons of full-length battens.	235
What are the drawbacks of in-mast furling systems?	235
What can be done to improve the performance of an in-mast furling mainsail?	236
What does a foam luff pad on the luff of a headsail do?	236
Do I need a sunshield?	236
How important is clew height?	236
How can I improve the performance of a cruising headsail?	236
My boat does not have a spinnaker and I am considering buying one for cruising. Should I buy an asymmetrical spinnaker or a symmetrical one?	236
Can I cut down an old headsail to make a storm jib?	237
Can I use my roller-furling sail reefed as a storm jib?	237
Do I need a separate trysail track?	237
How important are staysails?	237
Do I need telltales on my sails?	237
When I am sailing to windward the top telltale on my genoa starts to lift first. What should I do?	237
When I am overpowered while sailing on a beat should I ease the mainsheet or the main traveler?	237
How do I know when the mainsail is trimmed properly?	238
What does adjusting the backstay do?	238
Do I need running backstays on my mast?	238
How do I add power to my sails?	238
What is most important to remember when the wind is light?	238
When the wind is around 6-8 knots, how should my sails look?	238

- Explain how the mainsail trimmer can “drive” the boat.** 239
- At what point does it make sense for the headsail trimmer to leave his post to leeward and sit on the rail?** 239
- How can I manipulate spinnaker shape?** 239
- Are there any rules of thumb when trimming a spinnaker?** 239
- When would you need to band or stop a spinnaker?** 239
- What’s the most important thing to remember when setting a spinnaker?** 239
- What are some techniques for dousing a spinnaker with a dousing sock?** 240
- What are the main causes of sail degradation?** 240
- What are some important things to note when repairing sails?** 240

Chapter 15: THE WIND IS STILL FREE 241

The theory behind how boats sail

- Early Theory** 242
- Basic Concepts:** The Boundary Layer, Attached Flow, Separation, Pressure Gradients, The Angle of Attack, Lift Versus Drag 244
- Modern Theory:** The Kutta Condition, Creating a Vortex, Vortices Create Circulation, Streamlines, Creating Lift, Upwash, In Summary, Circulation in Practice, High-Aspect Versus Low-Aspect 248
- Adding a Mainsail:** The Slot Effect, How the Mainsail Affects the Jib, How the Jib Affects the Mainsail 257
- In Conclusion** 261

Appendix 263

Measuring Your Rig

- Sailplan Jargon** 264
- Measuring for a Mainsail:** Mainsail Measurement Sheet 265
- Measuring for a Headsail:** Headsail Measurement Sheet 268
- Glossary** 271
- Detailed Table of Contents** 280
- Basic Boat Diagram** 287
- Index** 288

BASIC BOAT DIAGRAM

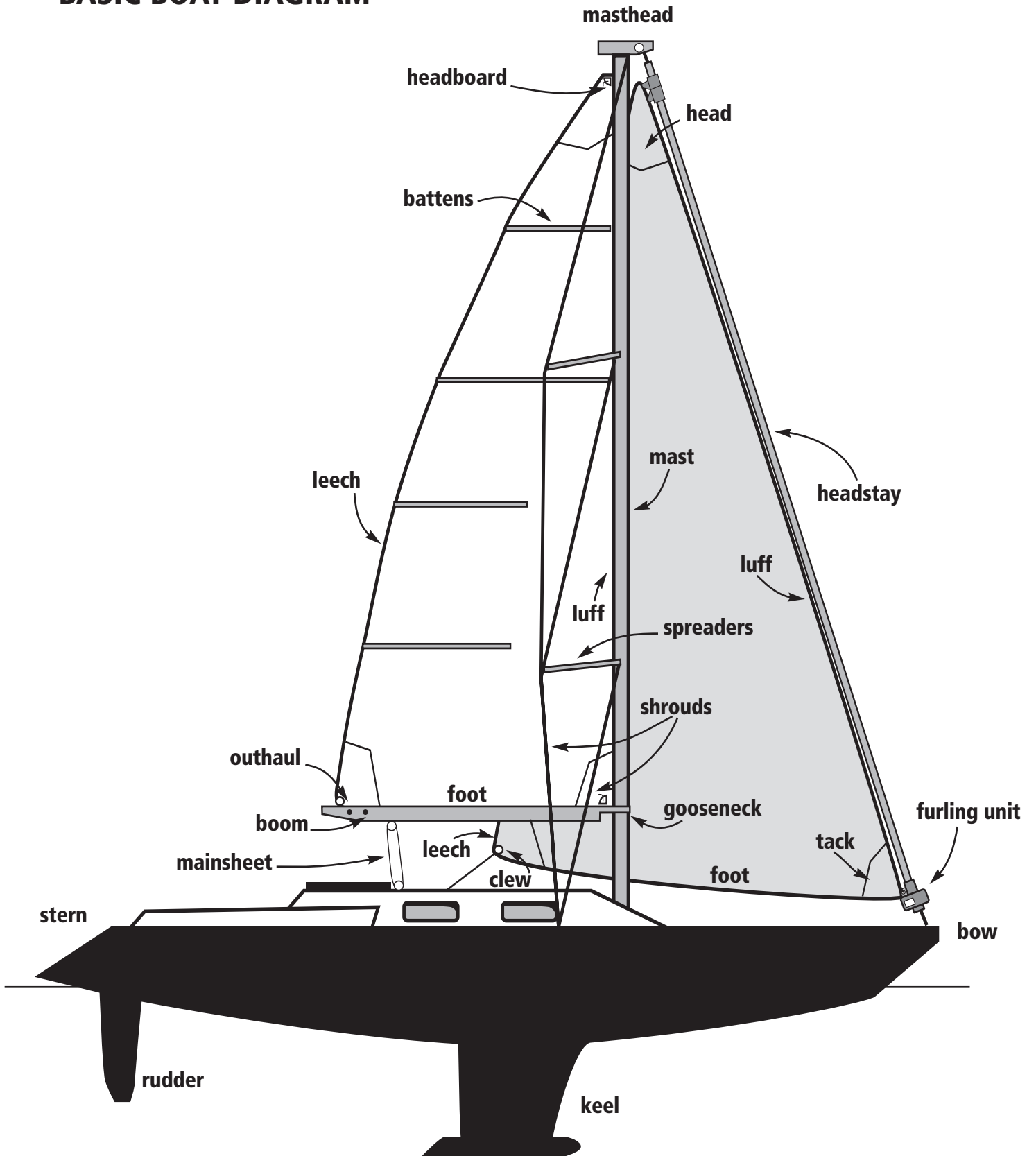

INDEX

3DL 1, 23, 38, 64, 66–76, 78, 99, 111, 233, 234

A

Afterguy 131, 134, 181, 192, 195–197, 199, 200, 202, 207–211, 271

Airforce Sails 11

Airframe 66, 67, 74, 75

Alaska Eagle 40, 199

America³ 48, 49

America's Cup 15, 19, 23, 33, 39, 47–49, 52, 61, 67, 84, 88–90, 113, 152, 258

Angora wool 158

Apparent wind 81–83, 85, 130, 136–138, 151, 159, 170, 172–174, 183–186, 188, 189, 197–199, 203, 206, 208, 209, 213, 234, 238, 257, 271

Around Alone vii, xi, xii, 19, 45, 73, 87, 96, 124, 139, 146, 231, 243, 262

Aspect ratio 255, 256, 271

Attached flow 129, 132–135, 170, 173, 174, 184, 244–246, 255, 257, 258, 271

Australia II 84

B

Backstay 86–90, 105, 160, 163, 164, 166, 168, 169, 172, 174–177, 179, 187–189, 203, 238, 263, 265, 271

Banks, Bruce 248

Banks Sails 248

Battens 88, 93, 99, 103–110, 112, 113, 116, 159, 161, 176, 189, 219, 225, 227, 228, 235, 266, 271, 277

Battlecry 144

Baudet, J.P. 69

Bear-away set 201–203

Bernoulli, Daniel 242, 243, 245, 246, 250, 253

Bias, bias stretch 26, 29–31, 33, 39, 41–44, 55, 67, 127, 129, 231, 271

Blades, Herbert 19

Block Island Race Week 3, 34

Bobst Group Armor lux vii, xii, 139

Boom vang 114, 115, 160–163, 179, 180, 189, 215, 216, 237, 272

Boundary layer 244–246, 250, 255, 257, 258, 261

Broadseaming 91, 92, 113, 235

C

Calendering 32, 232

Camber (see chord)

Carbon fiber 1, 19, 20, 23, 24, 49, 99, 218, 230, 231

Celanese 19, 22

Certran 19

Challenge Sailcloth 27, 34, 36

Chord, chord depth, chord depth ratio 79–86, 89, 99, 118, 132, 133, 135–137, 140, 157, 163, 164, 170, 171, 174, 176, 181–183, 234, 238, 239, 246, 247, 272

Circulation 148, 168, 169, 244, 250–257, 260

Code 0 135–137, 272

Code 1 137

Code 2 137

Code 3 137, 138

Code 4 137, 138

Code 5 137, 138

Conrad, Peter 66

Cotton 13–16, 125, 126

Creep 14, 19, 22, 37, 41, 48, 49, 230, 273

Crescent-cut sails 57–59, 233

Crimp 30, 31, 33, 38, 39, 42, 44, 45, 48, 73, 76, 78, 273

Cross-cut sails 16, 33, 39, 47, 54–59, 61, 64–66, 77, 94, 98, 101, 111, 119, 126–128, 166, 226, 229, 230, 232, 233, 273

Cruising Systems 195

Cuben Fiber 1–3, 25, 47–50, 65, 77, 87, 88, 129, 136, 232, 233

Cuben Fiber Corporation 49

Cunningham 99, 100, 105, 165–167, 175–177, 214, 273

D

D4 1, 38, 64, 66, 75, 76, 111, 234

Dacron 3, 5, 6, 9, 15–19, 25–38, 40–43, 46, 47, 56–60, 64, 77, 78, 98, 101, 111, 114, 115, 118, 139, 141, 147, 154, 155, 218, 220–222, 225, 226, 228–233, 273

Daisy Staysail 150, 151, 155, 156, 237

Dashew, Steve 149

Denier, denier per inch (DPI) 27–29, 33, 34, 36, 37, 44, 50, 153, 273

Diagonal yarns 43, 154

Dimension Fabrics 28

Diolen 16

Dousing sock 193, 194, 196, 198, 199, 240

Dow Chemical 22

Downhaul 182, 202

Downwash 253, 254, 261

Doyle Sailmakers 1, 6, 22, 38, 45, 64, 66, 75, 109, 116

Drum 214, 215, 219, 224

DSM 19

Dubois, Luc 69

Dubois, Thierry xi

Du Pont 15–17, 19, 20, 126, 273

Dutchman 117

Dyneema 19, 218

E

Everest Horizontal 138

F

Facnor 124

Farr 40 152, 158

Fastnet Race 144

Fazisi 224, 225

Fill, fill-oriented 26–30, 33, 34, 37, 42–44, 54–59, 78, 226, 231–233, 274

Fillers (resins) 18, 30, 31, 33, 35, 37, 220, 231

Film 18, 22, 25, 38, 39, 41–45, 49, 66, 68, 69, 71, 74, 76, 87, 136, 151, 153, 155, 220, 222, 231, 233, 274, 275

Finishing, finishes 16, 31–33, 35, 36

Finite Element Analysis 51–54

Finn dinghy 160

Flattening reef 99, 101, 166, 176, 177, 274

Flax 13–15

Flex 14, 16, 19, 20, 22, 49, 50, 230, 231, 274

Flying Scott 53

Foam luff pad 10, 119, 120, 236

Foot shelf 99–101, 274

Foreguy (also downhaul) 134, 182, 190, 192, 274

G

Gale sail 141

Genesis 66–69, 71, 75, 76, 233

Genoa turtle 215

Gentry, Arvel 241, 242, 258

Giorre, Etienne 195

Gordon, William 125, 126

Great Circle 18

Green, Marvin 21

Greige (gray) cloth 30

H

Harken 124

Headstay 86, 87, 92, 120, 134, 148, 164, 166, 175, 176, 196, 198, 207, 208, 235, 235, 236, 238, 258, 259, 261, 263, 271, 275–277

Headsail measurement sheet 269

Heat setting 30, 31

Honeywell Performance Fibers 16–18

Hood Sails 21, 32–34, 56

Hood, Ted 21, 106, 126, 127

Hoyt, Gary 149

Hoyt Jib Boom 148–150

Hyperion 195

I

Induced drag 83–86, 88, 175, 234, 275

J

J-44 12

Jibe 134, 181, 185, 200–202, 205–208, 275

Jibe-set 201, 203–205

K

Kent, Tim 138

Kevlar 1, 16, 19–21, 23, 34, 36, 44, 45, 50, 60, 69, 76, 77, 99, 114, 136, 153, 154, 218, 224, 230, 275

Kevlar Edge 20

Koch, Bill 48

Kutta Condition 249–251, 254, 257–261

Kwolak, Stephanie 19

L

Laminar flow 245, 246

Laminated sails (see carbon, Certran, Dyneema, Kevlar, molded sails, Pentex, PBO, radial sails, scrim, Spectra, taffeta, Technora, Twaron, Vectran)

Laser 29, 160

Lazy guy 134, 181, 185, 196, 275

Lazy jacks 47, 105–107, 115–117, 219, 235, 275

Lazy sheet 134, 181, 196

le Bon, Simon 224

Leading edge angle, angle of attack 85–87, 89, 171, 174, 175, 184, 187–189, 244, 247, 261

Leechline 10, 93, 99, 101, 102, 121, 174, 175, 227, 276

Levitt, Michael 260

Lift 84–86, 88, 132–135, 148, 160–162, 167, 170, 171, 175–177, 187, 213, 234, 236–238, 243–245, 249, 250, 252–256, 260, 276

Luff curve 79, 86, 91, 92, 113, 234, 235

M

Mack-Shaw Sailmakers 195

Mainsail traveler 160, 161, 174–177, 179, 187, 188, 213, 214, 237, 239, 261, 278

Mainsheet 159–163, 165, 170, 171, 174, 179, 186–188, 215, 216, 237–239, 276

Marchaj, C.A. 242

Mast bend 86, 89, 105, 113, 160, 163–165, 168, 169, 174, 176, 177, 179, 188, 234, 235, 238, 263, 265

Maudsley, Herbert 126
 Maximum draft location 82, 85, 87, 89, 118, 122, 140, 164–167, 171–177, 183, 184, 188, 239, 273, 276
 Melges 124
 Mitre-cut sails 54, 55
 Mizzen 149, 150
 Mizzen staysail 149, 150, 237
 Modulus 14, 16, 17, 19–23, 36–38, 41, 44, 45, 64, 153, 155, 276
 Mojo 124
 Molded sails (see also 3DL, Cuben Fiber, D4, Genesis, North Sails, Tape Drive) 10, 16, 38, 47, 65–78, 111, 147, 233, 234
 Mylar (see film)

N

Newton, Sir Isaac 247
 Niobe 125
 Nirvana 21
 Nordac Fabric 26
 North Sails 1, 23, 26, 38, 64, 66, 68–74, 81, 89, 127, 137, 138
 Novak, Skip 46
 Nylon 3, 17, 32, 38, 40, 50, 126, 128, 129, 137, 150, 151, 158, 159, 194, 218, 220, 222, 223, 225, 229

O

One World 23
 Open 50 19, 138
 Open 60 53, 87, 164, 256
 OSTAR 195
 Outhaul 165, 174–177, 179, 186–189, 203, 238, 265, 266, 276

P

PBO 22, 23, 45, 218, 230
 Pedrick, David 21
 Pelagic 46

PEN 41–43
Pen Duick 195
 Pentex 9, 17, 18, 41, 45–47, 77, 78, 98, 99, 111, 115, 154, 218, 229, 230, 234
 Pepper, Mark xi
Pindar 72, 227
 Pinstripe 34, 36
 Plies 56–59, 111, 112, 232, 233
 Pole guy 196, 197, 199, 200, 276
 Polyester (see Dacron)
 Profurl 124

Q

Quantum Sail Loft 79, 92
 Quest 131

R

Radial sails 16, 33, 39, 59–66, 77, 94, 98, 111, 119, 127–129, 166, 229, 230, 233, 276
 Ratsey and Laphorn Sailmakers 54, 126, 127
 Reefs 10, 99, 102, 103, 112–115, 119–124, 140, 141, 149, 155, 156, 162, 163, 177, 186, 215, 216, 227, 235, 236, 277
 Reichel Pugh 124
 Resin (see fillers)
 Richards, Emma 72, 227
 Riley, Roy vii
 Roach 88, 99, 103–111, 113, 114, 136, 235, 236, 265, 277
 Roller furling 7, 47, 106–115, 118–124, 136, 140–142, 148, 150, 151, 155, 215, 235–237, 266
 Rotary mold 70, 73, 74
 Running backstays 160, 163, 164, 176, 188, 197, 238, 265

S

Sail Magazine 241
 Saw-tooth sails 57–59, 232
 Scotch-cut sails 54
 Scrim 38, 39, 42, 44, 45, 59, 66, 67, 71, 76, 129, 136, 151, 154, 155, 229–231, 275, 277
 Seconds 10
 Self-tacking jib 148, 149
 Separation 81, 133, 170, 172–174, 188, 234, 244, 246, 258–261
 Sheet lead 167, 168, 175–177, 179, 181, 183, 185–188, 236, 237
 Sobstad sailmakers 66–68
Solidaires xi
 Soling 53
 Sparcraft 199, 200
 Spectra 1, 16, 18, 19, 23, 25, 38, 44–50, 77, 78, 98, 111, 114, 115, 151, 154, 200, 218, 230–232
Sphinx 126
 Spinnaker 3, 9, 17, 38, 49, 50, 57, 60, 125–138, 155, 156, 172, 180–186, 189, 191–212, 220–224, 226, 229, 236, 238, 239, 271, 272, 277
 Spinnaker pole 131, 134, 181–185, 190, 194, 196, 197, 199, 200, 202–206, 208–211, 236, 239, 277
 Spinnaker sheet 131, 134, 181, 183–185, 192, 194–198, 202, 207, 208
 Spinnaker sock 137, 192–198, 239
 Spinnaker turtle 196
 Square Weave 33
 Backpack 116, 117
 Stagnation streamlines 248, 249, 252–254, 258, 259
 Starting vortex 250–252, 255, 257
 Sticky-back Dacron 219–225
 Storm sails 139–146, 155, 156, 237
 Stoway mast 106

Streamlines 252–254, 258, 259

Swan 144

Swing batten 109, 236

T

Taberly, Eric 195

Taffetas 20, 22, 38, 43–46, 66, 73, 77, 147, 152, 154, 230, 232–234, 275, 278

Tall Boy 150, 151

Tape Drive 1, 64, 66, 74–76, 111

Team Adventure 1, 2, 47, 50

Technora 20, 218, 222

Tedlar (see film)

Teijin 20, 21

Telltales 13, 119, 122, 157–160, 168, 171, 174, 176, 177, 180, 188, 237, 238, 278

Tenacity 14, 16, 37, 232, 278

Tensile strength 14, 16, 21, 22, 35, 38, 51, 278

Terylene 16

Tetoran 16

The Race 1

The Tacker 198

Titan 75, 178

Tomlinson, Rick iv

Tommy Hilfiger Freedom America 164

Topping lift 134, 162, 182,, 197, 200, 202, 278

Toyobo 22

Transitional flow 245, 246

Transpac Race 152

Trevira 16

Trim stripe 119, 121

True wind 82, 83, 175

Trysail track 142, 143, 237

Turbulent flow 245, 246

Twaron 21, 23, 44, 153, 154

Tweakers 210, 212, 278

Twist 82, 83, 85, 89, 160–162, 167, 170, 174, 176, 177, 179, 181, 189, 213, 214, 234, 278

Type 52 Dacron 16, 232

Type 57 Dacron 16

U

UK Sailmakers 1, 64, 66, 74, 75

UV cover 10, 120, 121, 142, 228, 236

Ultraviolet light 14, 16, 18–22, 34, 36, 41, 42, 44–47, 49, 73, 76, 77, 112, 152, 217–219, 226, 230, 232, 278

Upwash 253, 254, 258–261

V

van Breems, Martin 117

Van Liew, Brad 164

Vang (see boom vang)

Vectra 22, 41

Vectran 1, 22, 23, 34, 44–47, 50, 98, 115, 136, 151, 155, 218, 229, 230, 232

Vendée Globe 19, 45, 73

Volvo 60 256

Volvo Ocean Race 19, 73, 90

W

Warp, warp-oriented 26–31, 33, 34, 37, 38, 42–44, 55, 59, 60, 128, 129, 226, 231, 232, 273, 279

Warranty 11

Weft (see fill)

Whidden, Tom 260

Whitbread 60 135

Whitbread Round the World Race 33, 40, 135, 193, 199, 214, 215, 224

Windex 159

Windseeker 150, 151, 155, 156, 173, 237, 238

Working staysail 147, 148, 150, 155

Woven sails (see cotton, Dacron, flax, nylon)

Y

Yarn stops, bands 136, 137, 192, 193, 196–198, 208, 239

Yield strength 35

Z

Zylon 22

Sailing

“*Maximum Sail Power* is the best book on sails and sail trim to come along in a generation. Brian Hancock knows his subject and has the sailmaking experience and sea miles to know what really works and what does not out there on the open sea. If you are in the market for sails or want to become a better sailor, *Maximum Sail Power* will steer you straight and true.”

–George Day, Publisher & Editor, *Blue Water Sailing*

“Brian Hancock is the rarest of seagoing creatures, a consummate sailor with countless miles in all conditions under his keel, and a gifted writer who can both spin a yarn and transpose complex technical material into clear, understandable prose. His *Maximum Sail Power*, a definitive treatise on the art and science of harnessing the breeze, joins a select handful of classic sailing books that deserve a space on the shelf of any well-found sailing vessel.”

–Herb McCormick, author, *New York Times* writer, editor of *Cruising World Magazine*

“Brian’s book covers it all including how to trim and handle sails, and more importantly how to understand the subtleties of the wind and how it relates to sails.”

–Bernard Stamm, winner 2002/03 Around Alone (Class 1)

“While Brian was writing this book he was also working closely with our team on *Tommy Hilfiger Freedom America* to develop the sail program and make a suit of sails that would not only win the race for us, but make it around the world in one piece. It’s clear that he knows his stuff. The sails performed perfectly . . . All that knowledge and experience is contained in this book and I urge you to read it.”

–Brad Van Liew, winner 2002/03 Around Alone (Class 2)

“Brian was . . . a key team member in the sail development for the mega-cat *Team Adventure* and through his bountiful knowledge and global experience we were able to circumnavigate the world without any sail problems. It’s clear that he knows his stuff, not only for big catamarans, but for more conventional race boats and cruising boats, as well.”

–Cam Lewis, Olympic medallist, skipper of *Team Adventure*

“Brian Hancock does a beautiful job blending the art and science of sail technology. *Maximum Sail Power* makes the process of using sails and understanding their theory easy.”

–Gary Jobson, America’s Cup winner, ESPN commentator

“The mystery of how to obtain the best performance from your sails has been exposed. This book will be of inestimable value to the learner and experienced sailor alike.”

–Sir Robin Knox-Johnston, first sailor to solo circumnavigate the globe non-stop

“Brian’s book covers what you need to know . . . He has written a concise book in language we can all understand—you can tell Brian has a passion for the sport and masses of experience to share in both sailing and sailmaking.”

–Ellen MacArthur OBE, 2nd place 2000–01 Vendée Globe, UK Yachtsman of the Year

“Brian’s involvement with the sails on all my sailing projects from the early Whitbread races to my latest expedition sailing vessel *Pelagic Australis* has been integral to the success of each project. This is a storehouse of information that will be useful to the novice boat owner or the experienced cruiser/racer alike . . .”

–Skip Novak, four-time Whitbread veteran, co-skipper of *Innovation Explorer* in The Race

“*Maximum Sail Power* is a well-written book by a well-known sailor. It is a comprehensive guide to how sails are made and work for all levels of sailors. This book is a must-read for all sailors.”

–Tom Whidden, President, North Sails

ISBN 0-9722026-0-9



nomad press

\$44.95
\$67.95 CAN