

Heart Warming Life Series

# UNIT

POLYHEDORON

ORIGAMI

TOMOKO FUSE

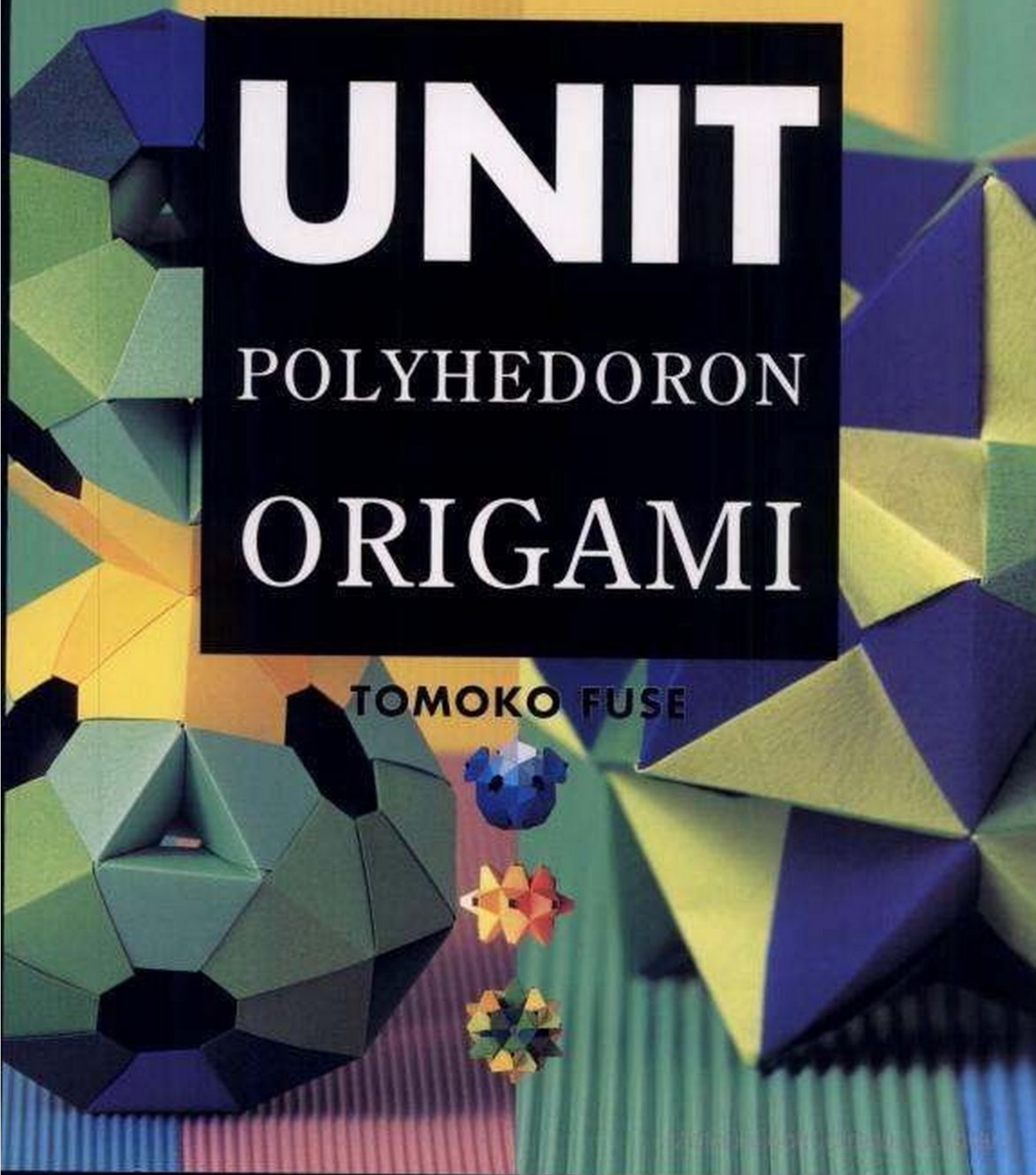



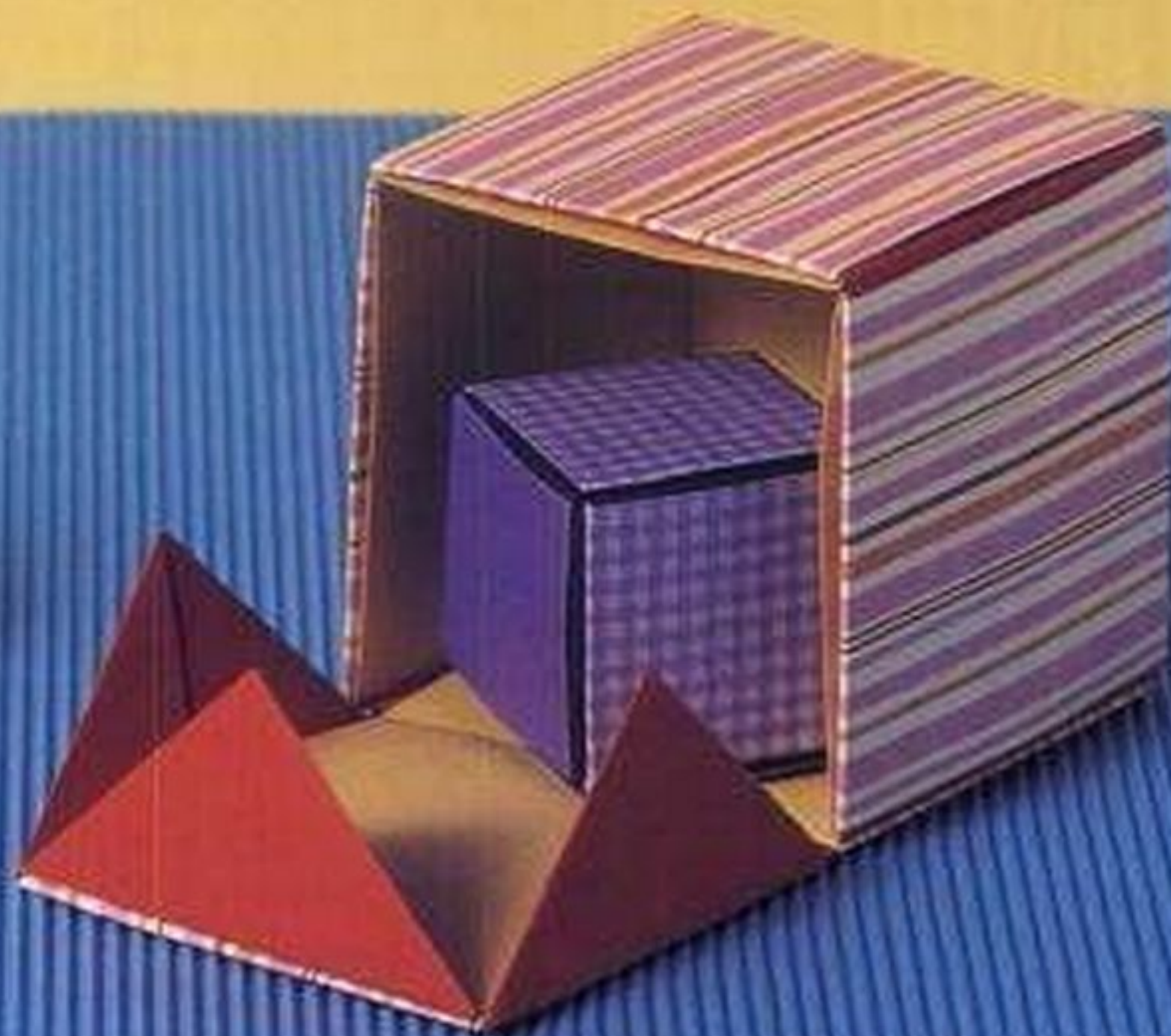

# CUBE | level ★

15cm × 15cm

Consider the various schematic diagrams.



(X6)



(X12)

The cubes in the photo were assembled using joint B.

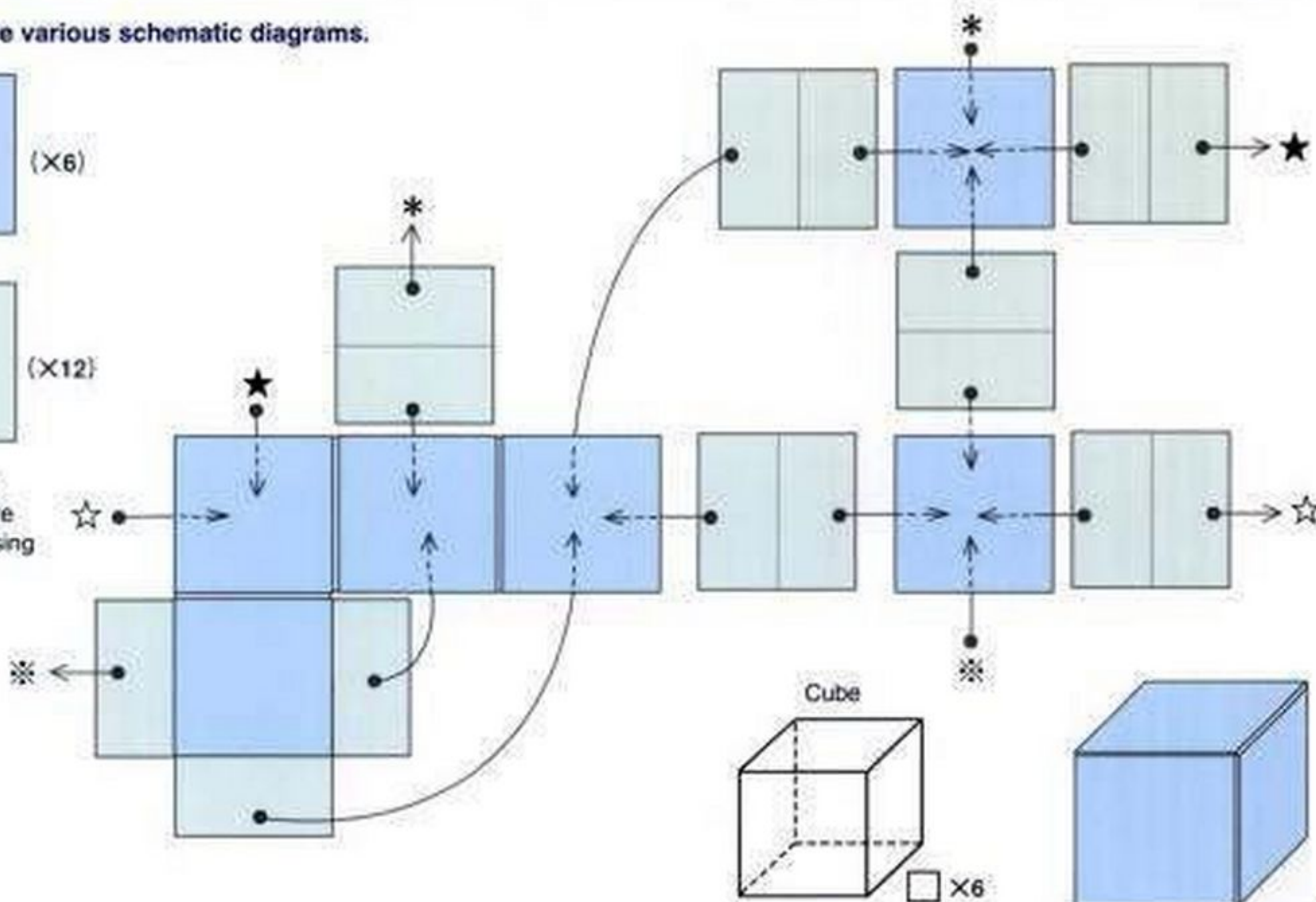



# EQUILATERAL TRIANGULAR FLAT UNITS

level ★★

15cm × 15cm

The unit has pockets on three sides, and it is assembled by inserting joints into them.

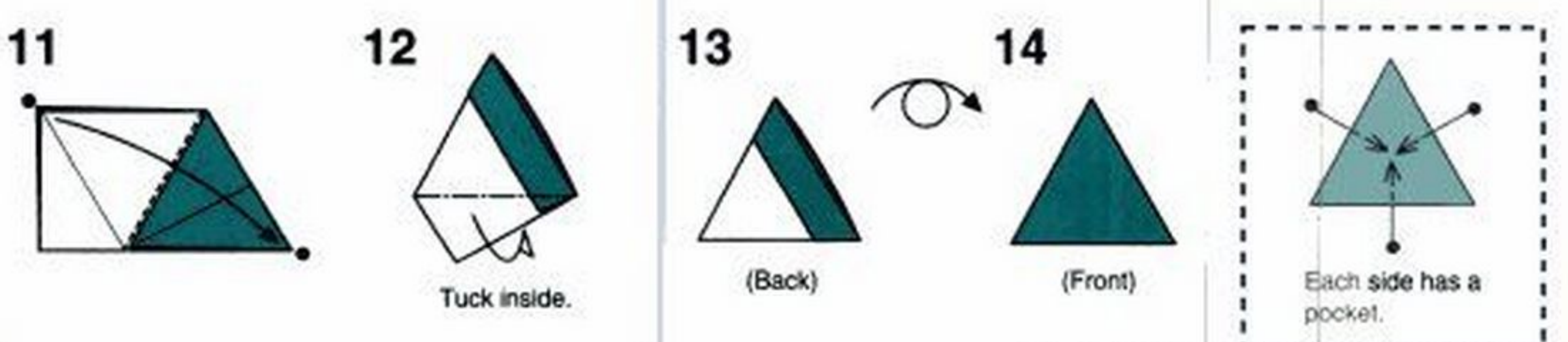
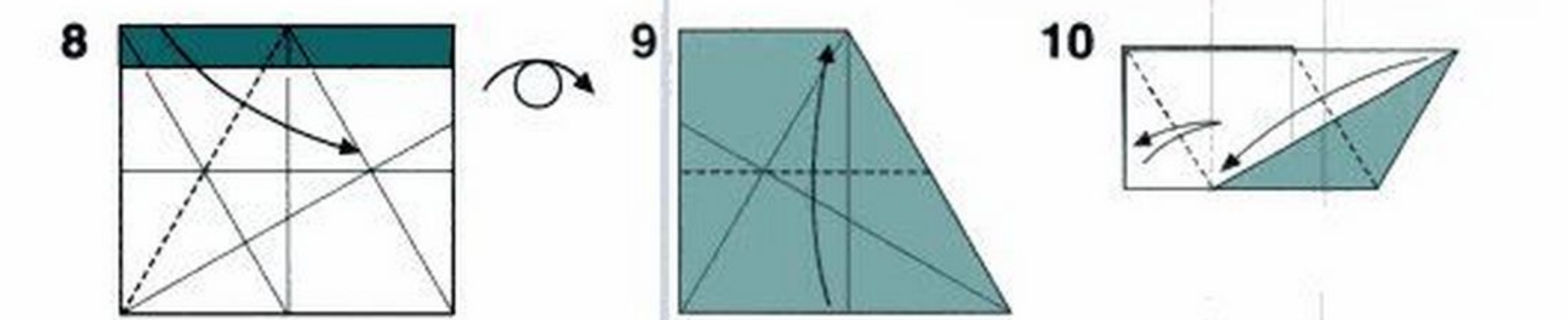
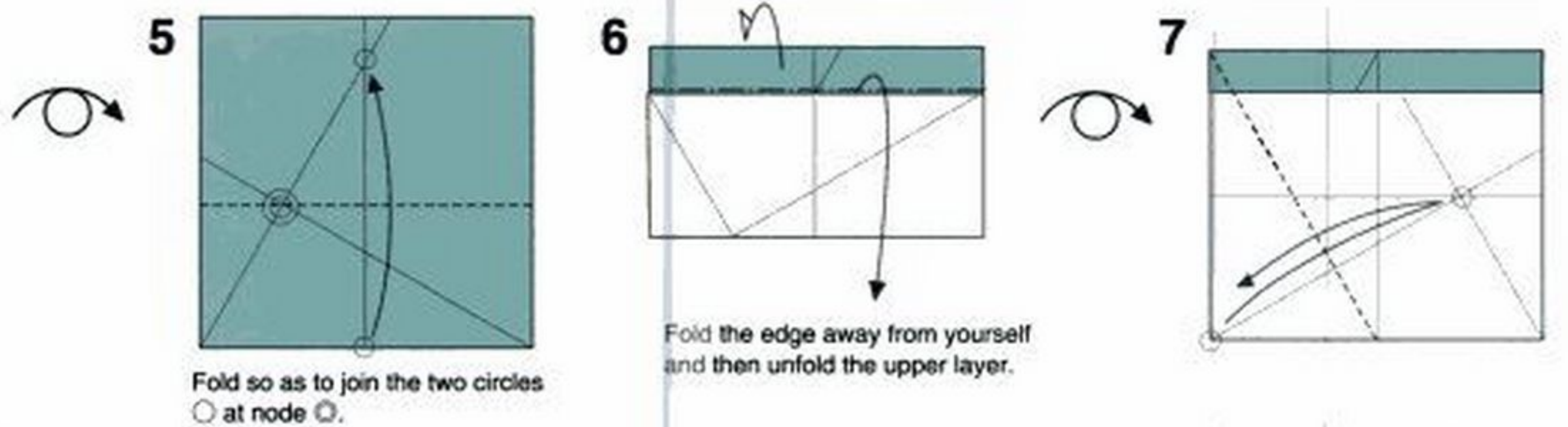
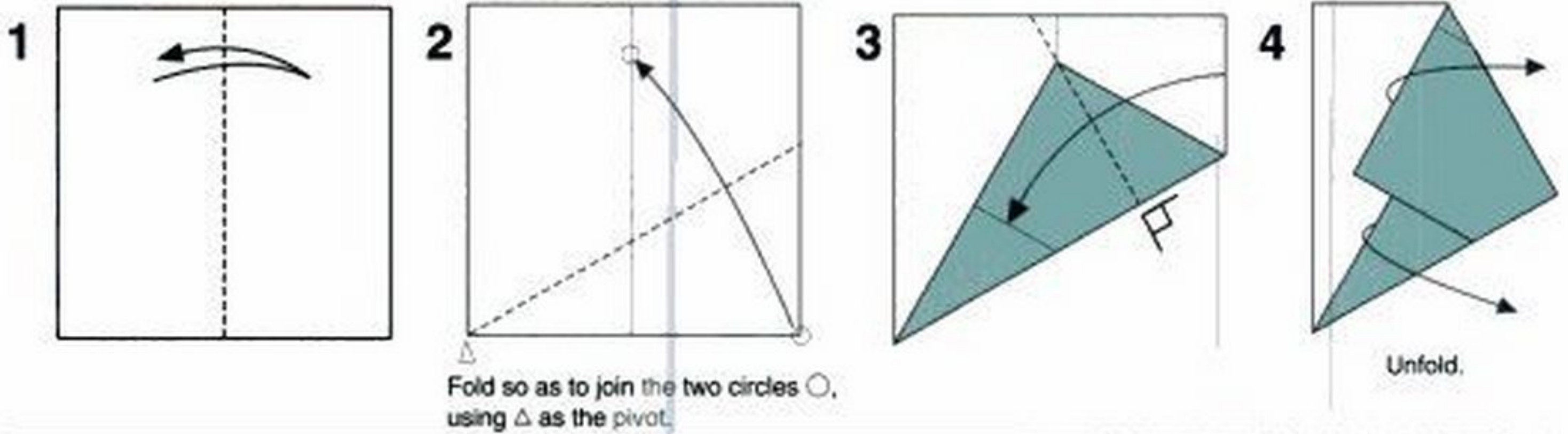



## Joint B

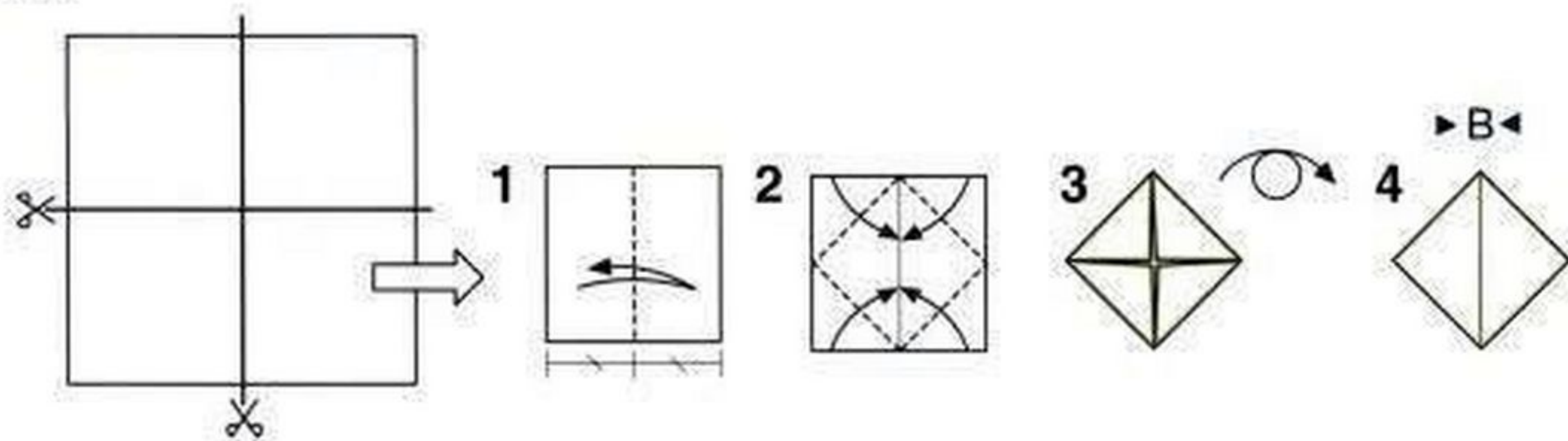

## REGULAR TETRAHEDRON

level ★

15cm × 15cm

Equilateral  
Triangular Flat Unit



(X4)

Joint B



(X6)

[Assembly Method]

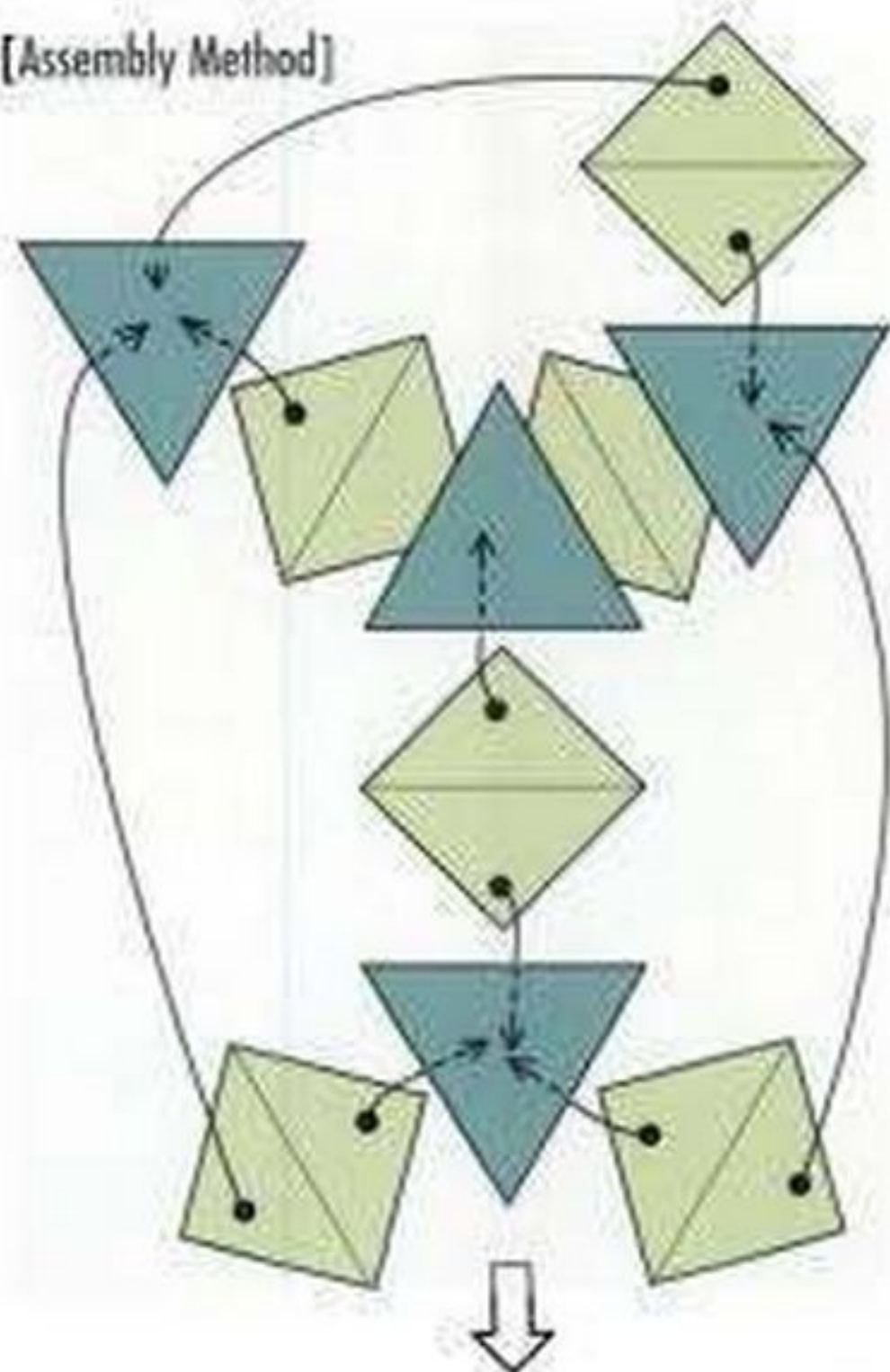

Insert the  
joint into the  
uppermost  
pocket.

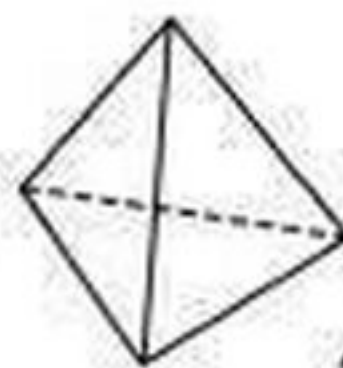

△ X4

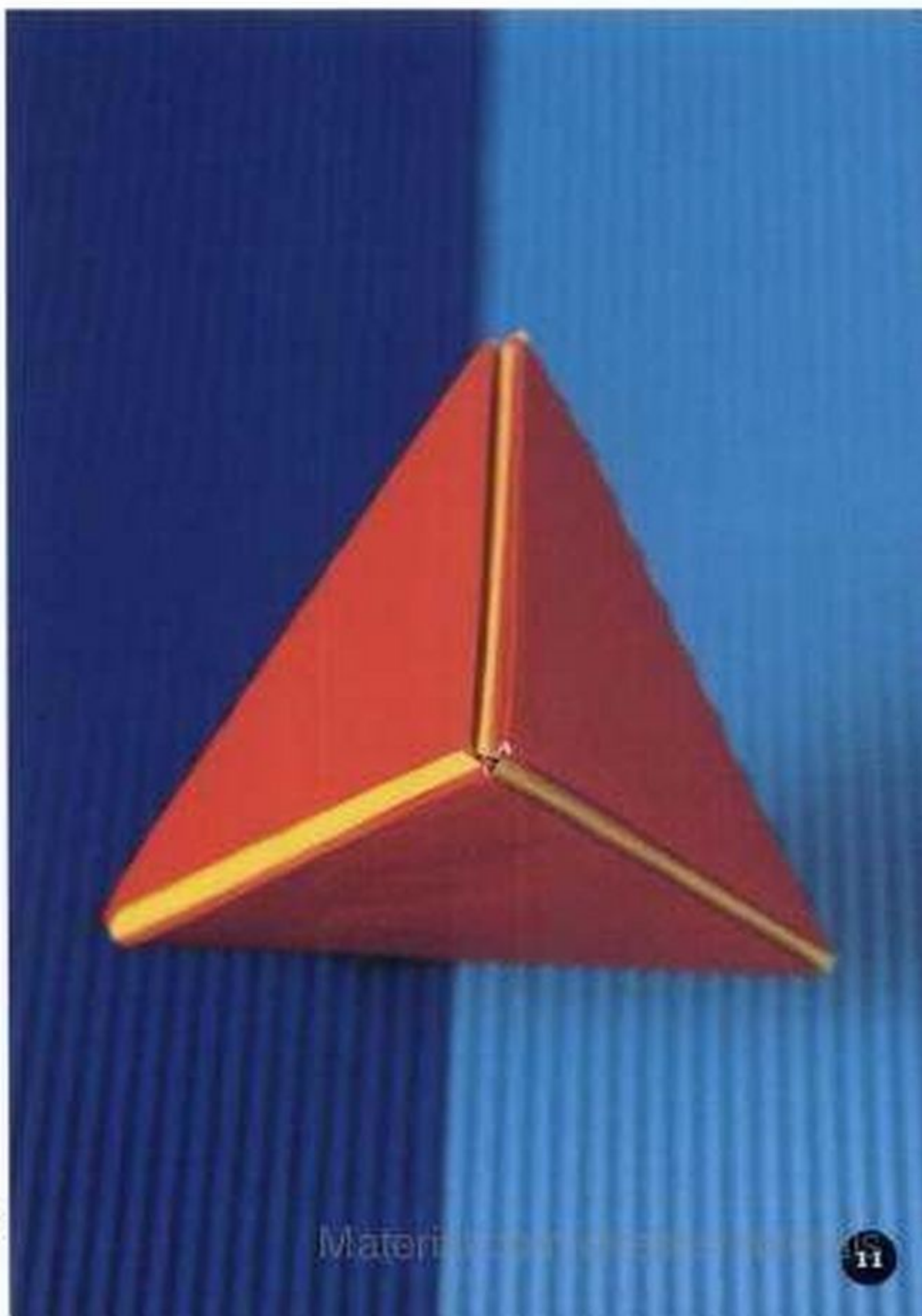



Equilateral Triangular Flat Unit (p. 10)

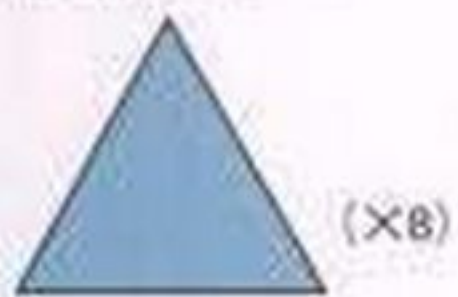

Joint B (p. 11)



Regular Octahedron

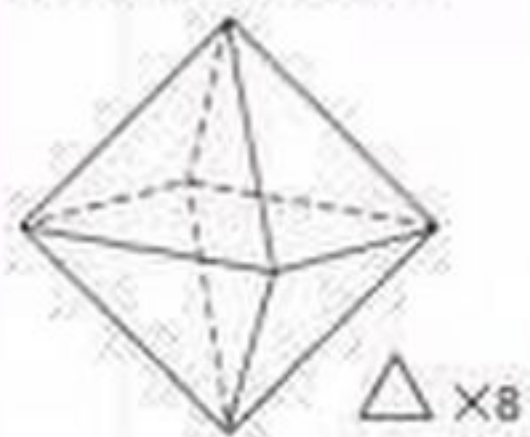

Equilateral Triangular Flat Unit (p. 10)

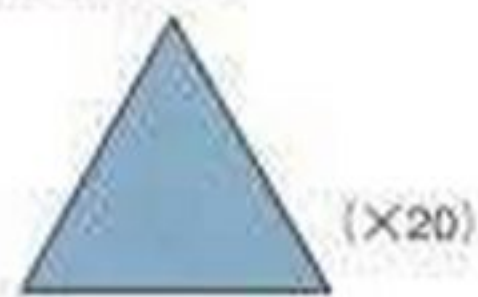

Joint B (p. 11)

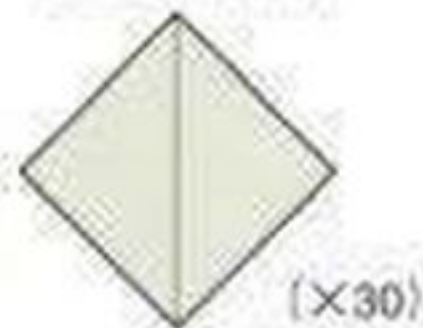

Regular Icosahedron

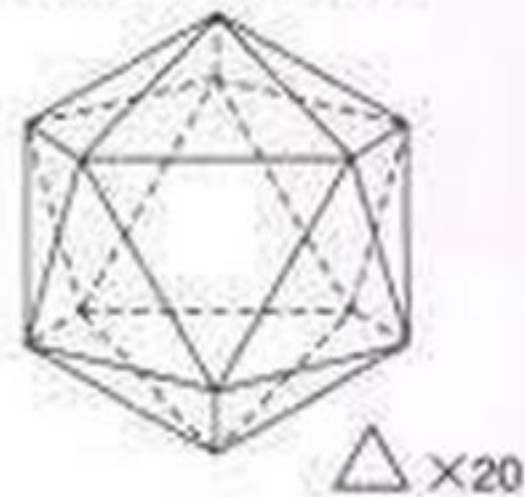



# TRUNCATED REGULAR TETRAHEDRON

Using equilateral  
triangular flat units.

level ★★

12cm × 12cm

You can make a regular hexagon by joining 6 equilateral triangular flat units. It is possible to combine this hexagon with equilateral triangular units.

[Assembly Method]

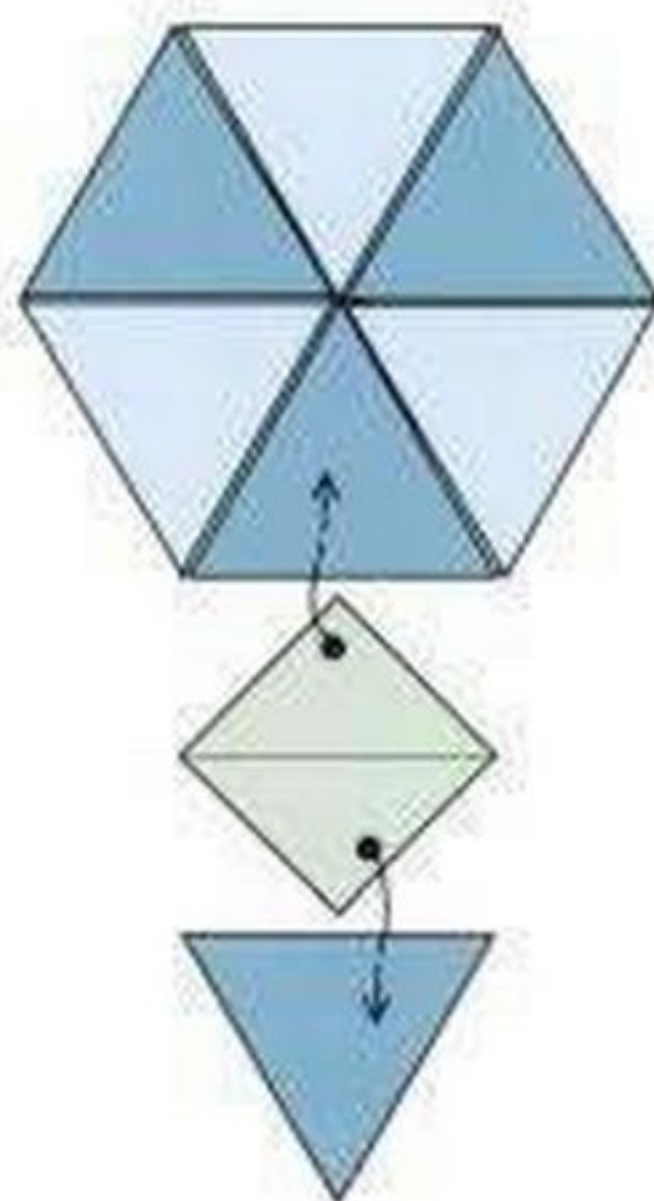
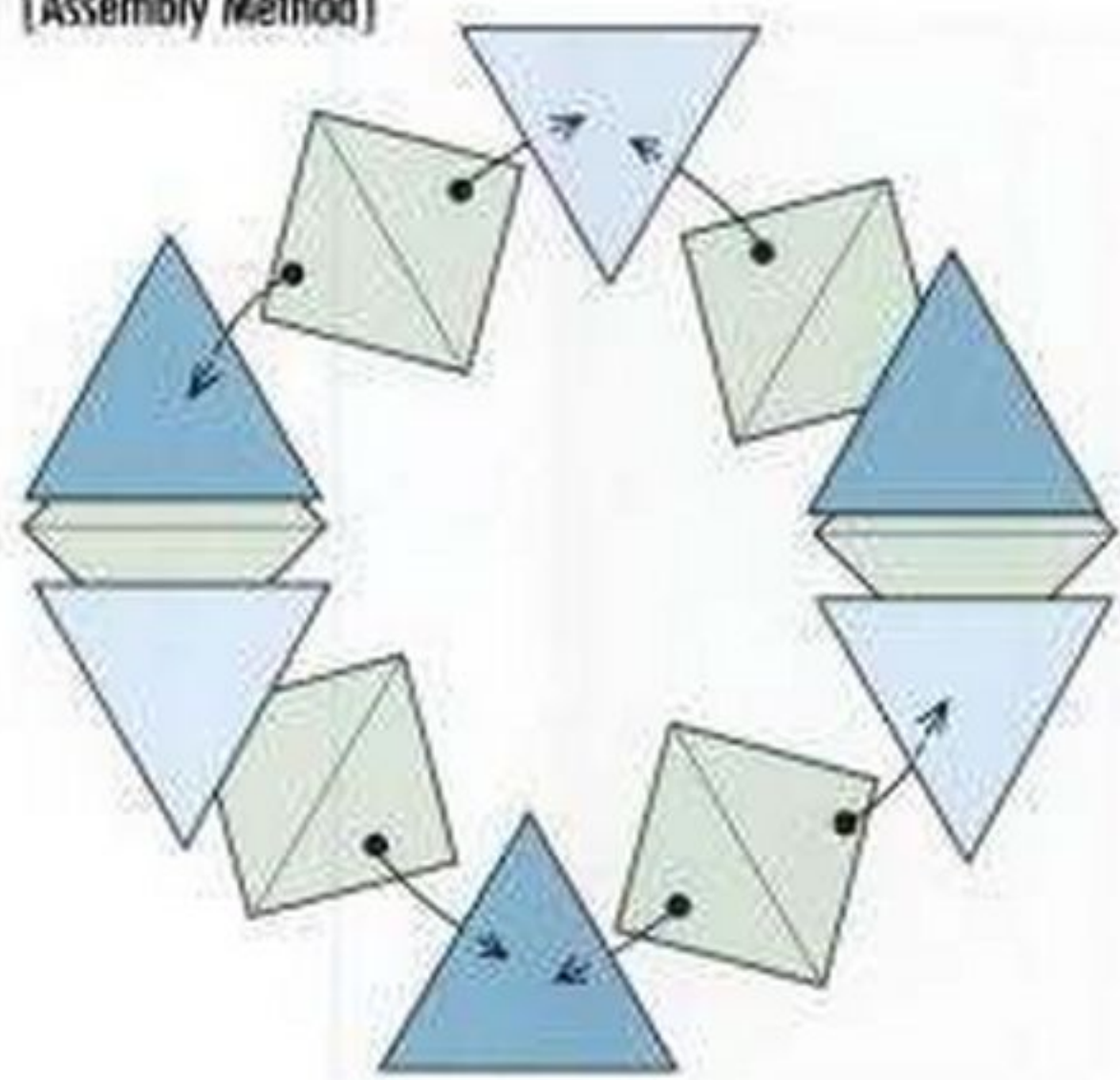

Equilateral Triangular  
Flat Unit (p.10)



Joint B (p.11)

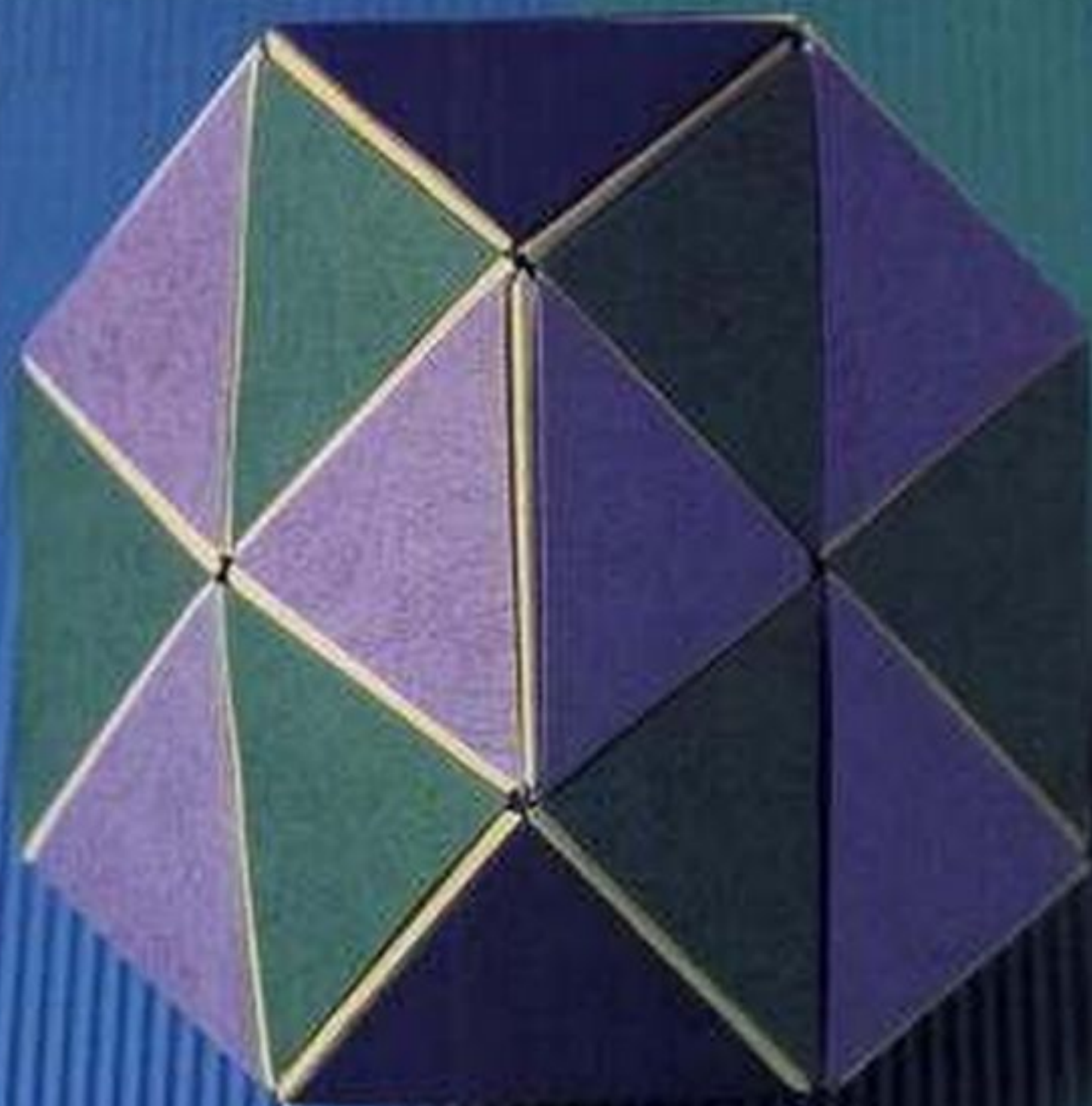
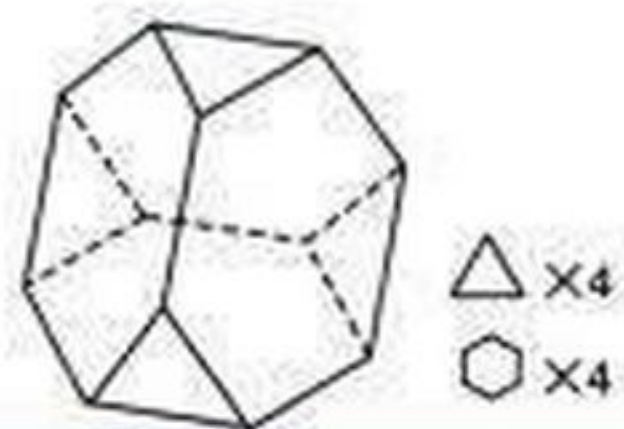
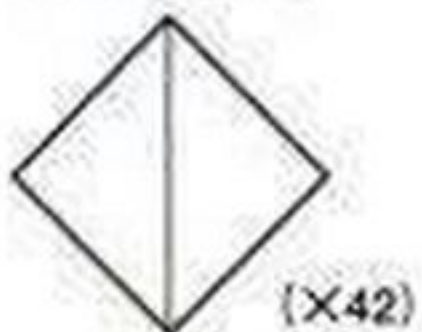



# 2

## COMBINATIONS OF SQUARES AND EQUILATERAL TRIANGLES

Squares and equilateral triangles folded from the same size of paper have sides of the same length, and it is possible to connect them. By adding even more components, you can make large, splendid polyhedrons.

**ELEMENTS AND FLAT UNITS OF EQUILATERAL TRIANGLE** /p.18

**REGULAR OCTAHEDRON**



**VARIANT CUBE** /p.17

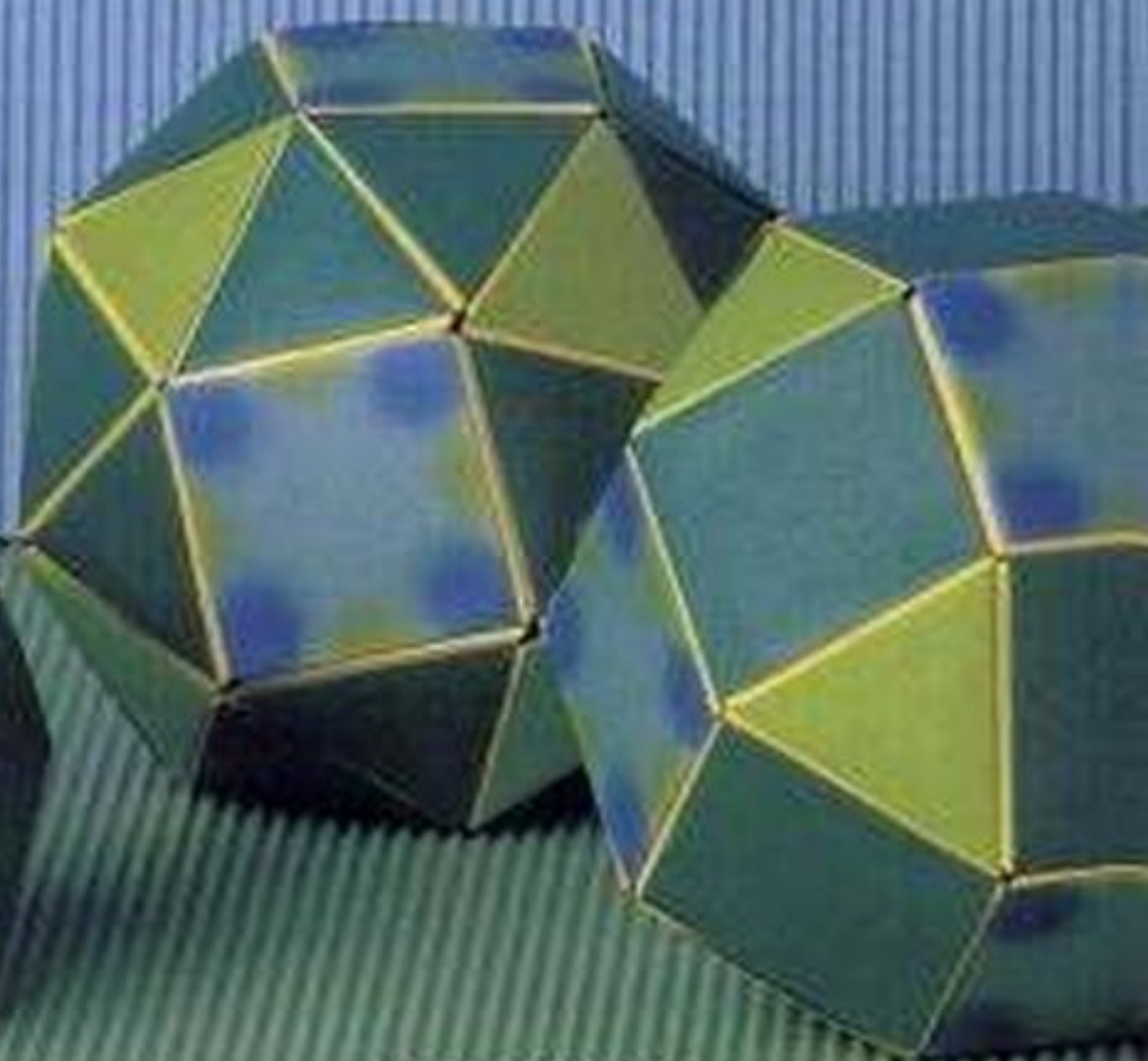

**CUBOCTAHEDRON** /p.16

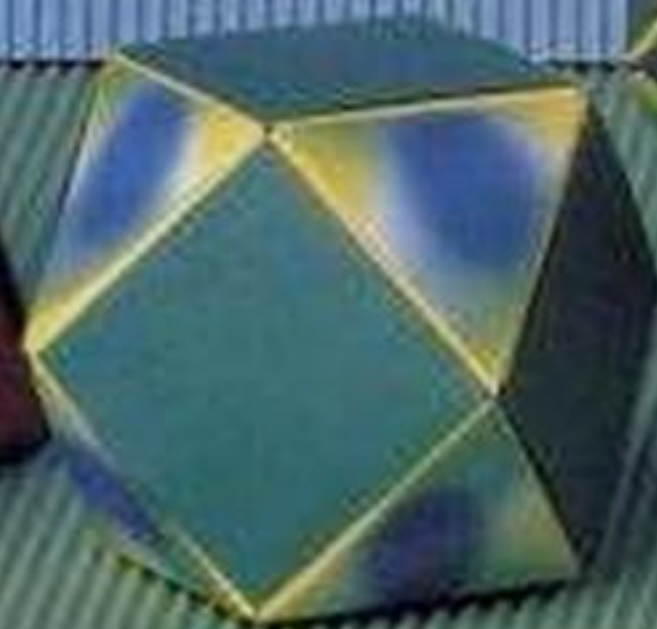

**RHOMBIC CUBOCTAHEDRON** /p.16



**A STRUCTURE MADE OF 20 CUBOCTAHEDRONS /p.21**

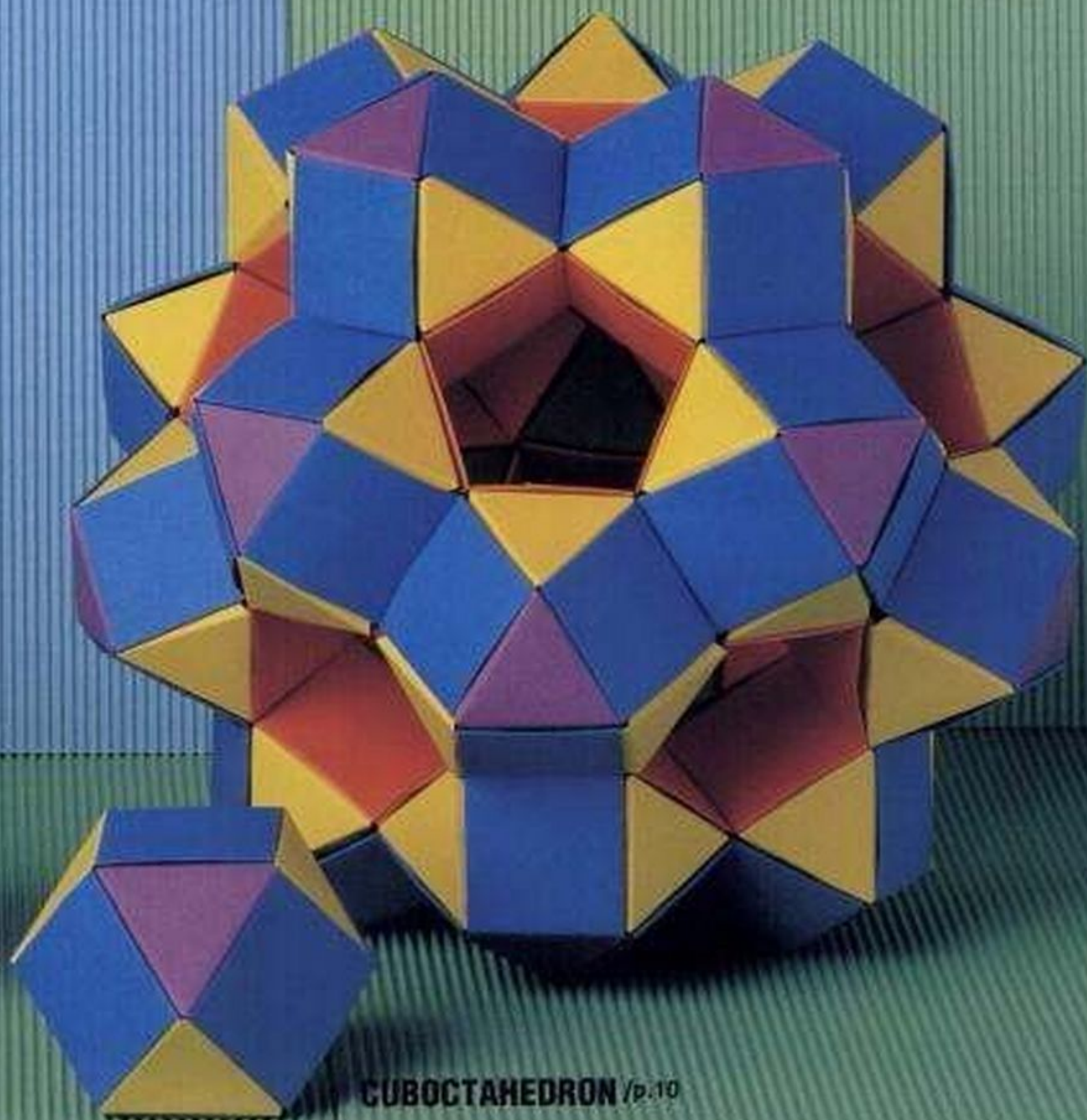

**CUBOCTAHEDRON /p.10**



# CUBOCTAHEDRON AND RHOMBIC CUBOCTAHEDRON

level ★★

7.5cm × 7.5cm

Square and equilateral triangular flat units folded from the same size of paper have sides of the same length, and it is possible to join them to make various solids.

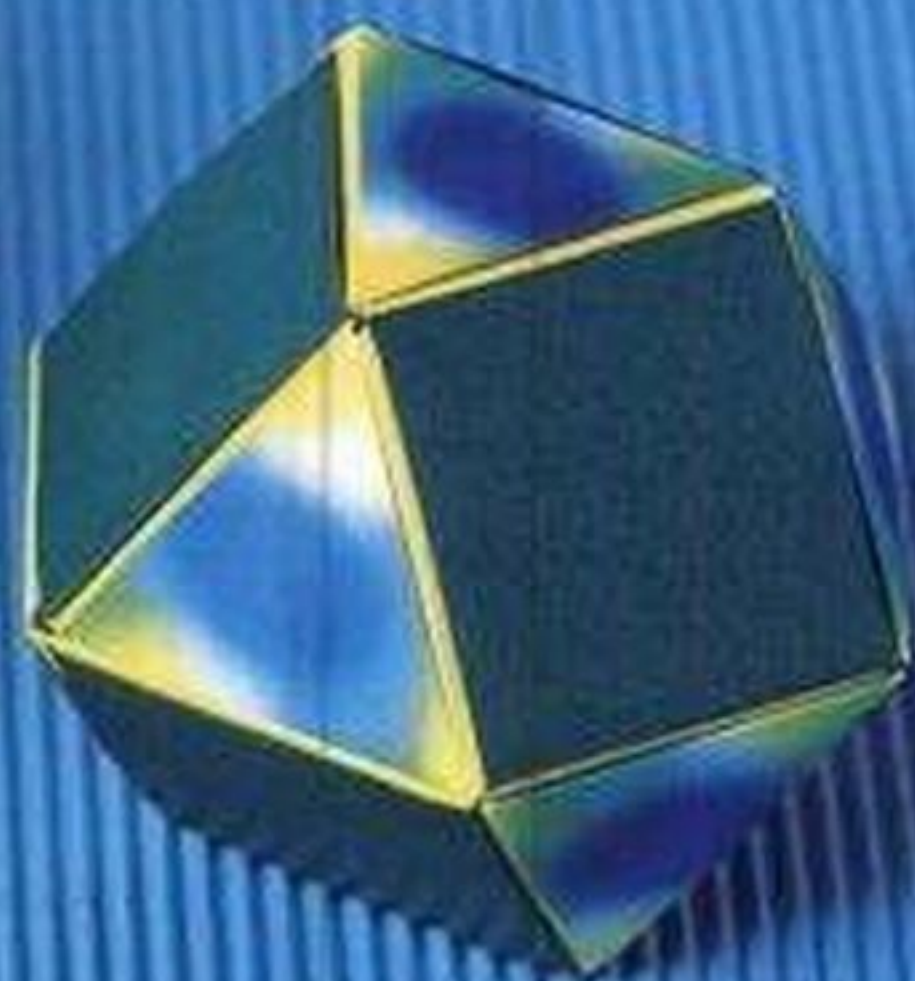
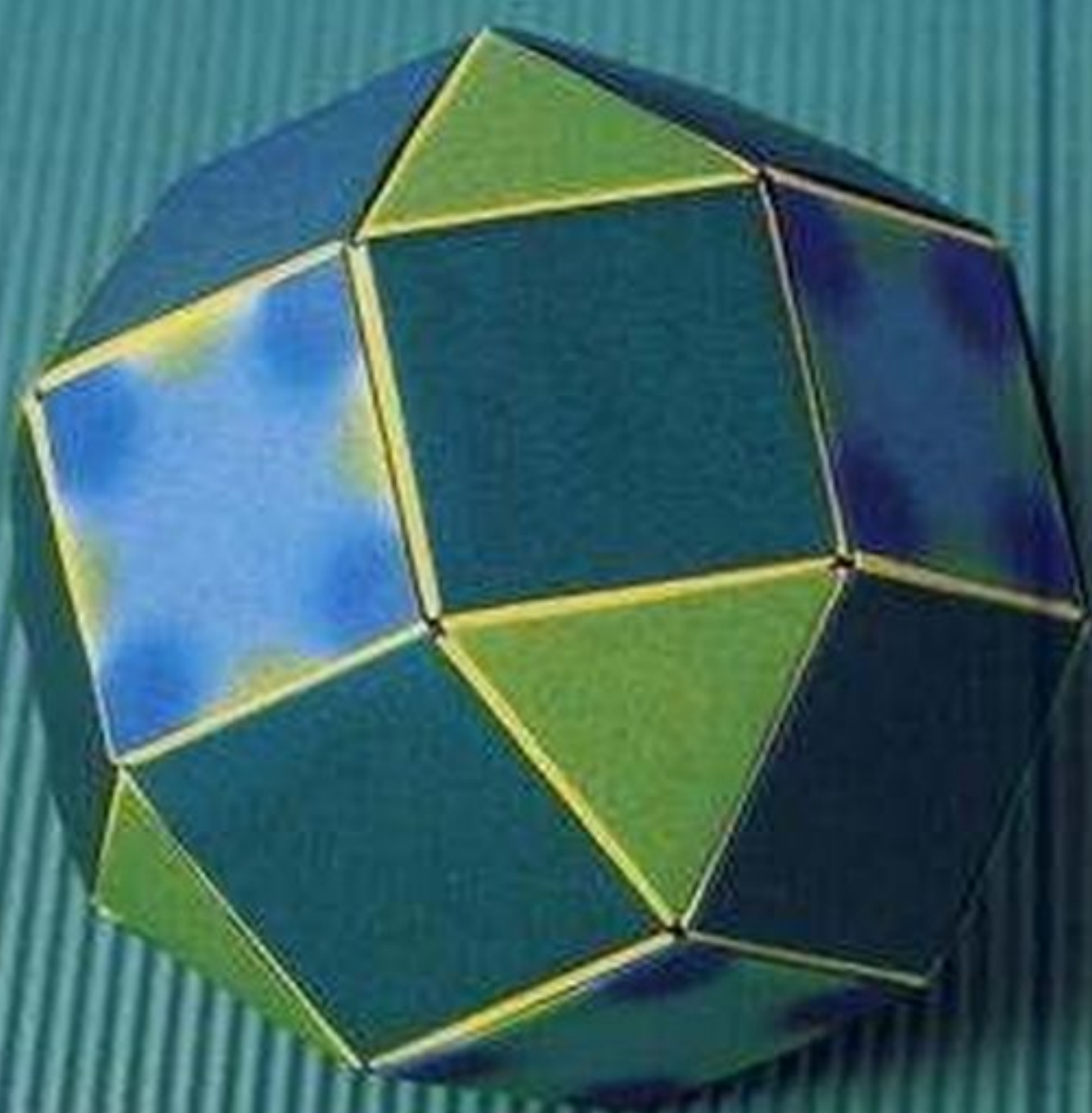
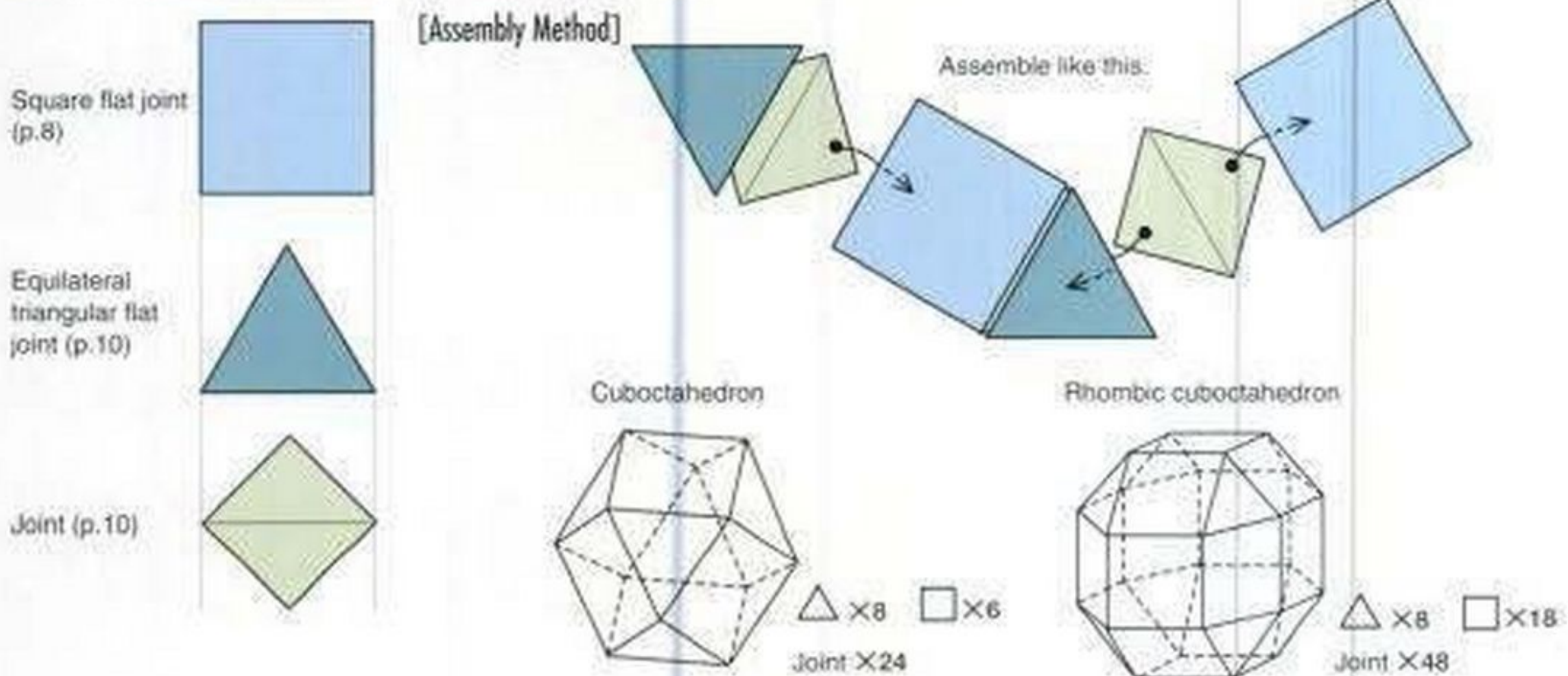



Variant cube

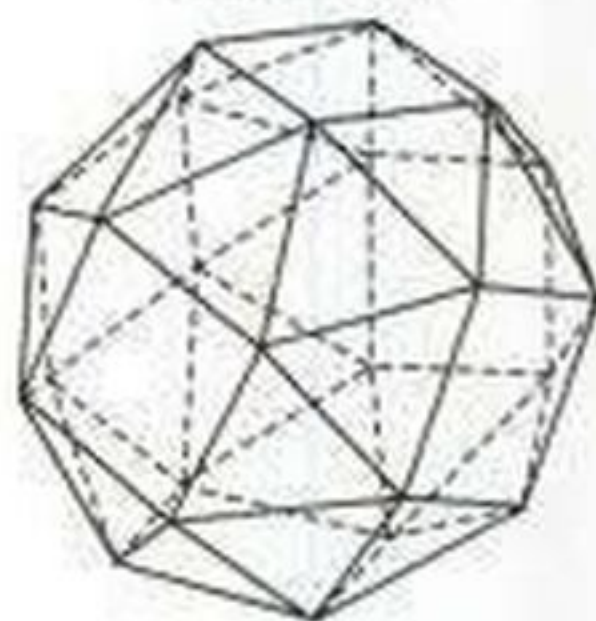

△ × 32   □ × 6

Square flat joint (p.8)



(×6)

Equilateral triangular flat joint (p.10)



(×32)

Joint B (p.11)



(×60)

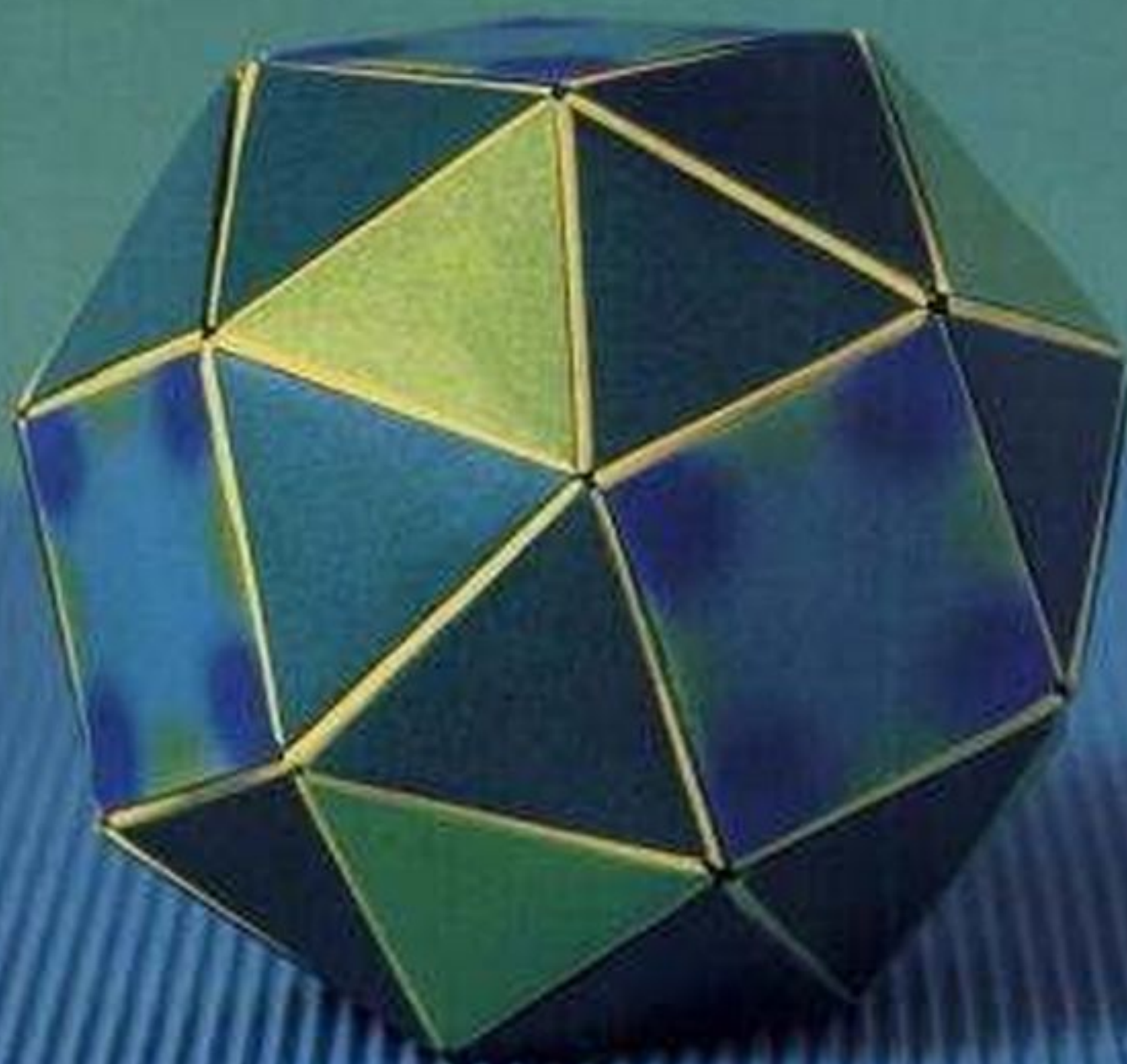



# EQUILATERAL TRIANGULAR ELEMENTS AND FLAT UNITS

## EQUILATERAL TRIANGULAR ELEMENTS

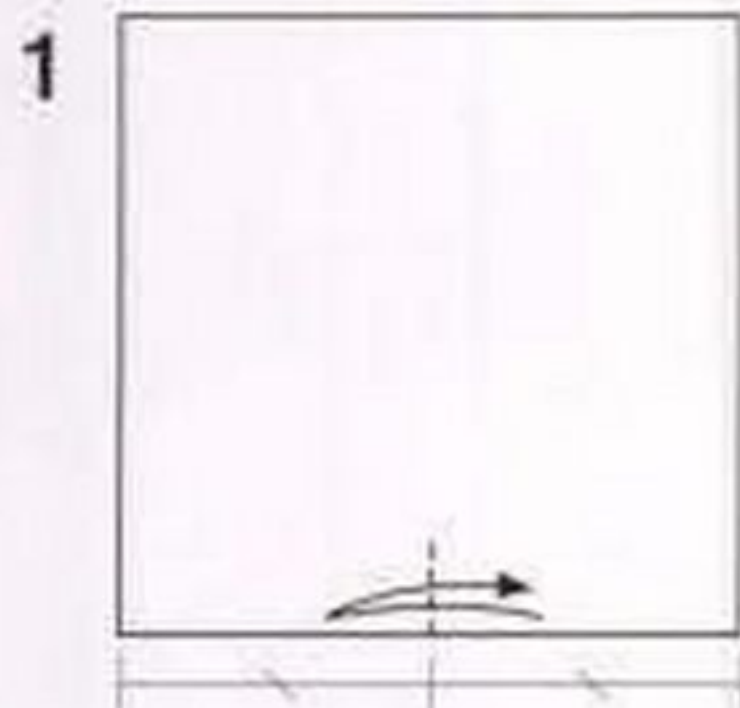

Make a short crease on the lower side.

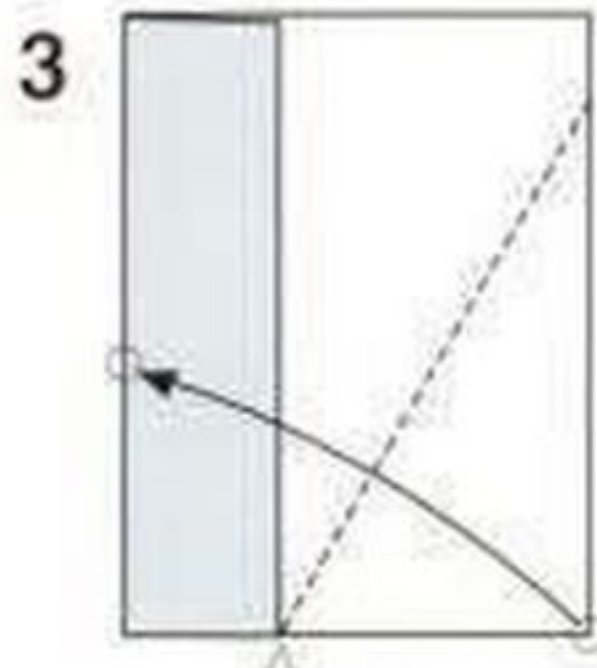
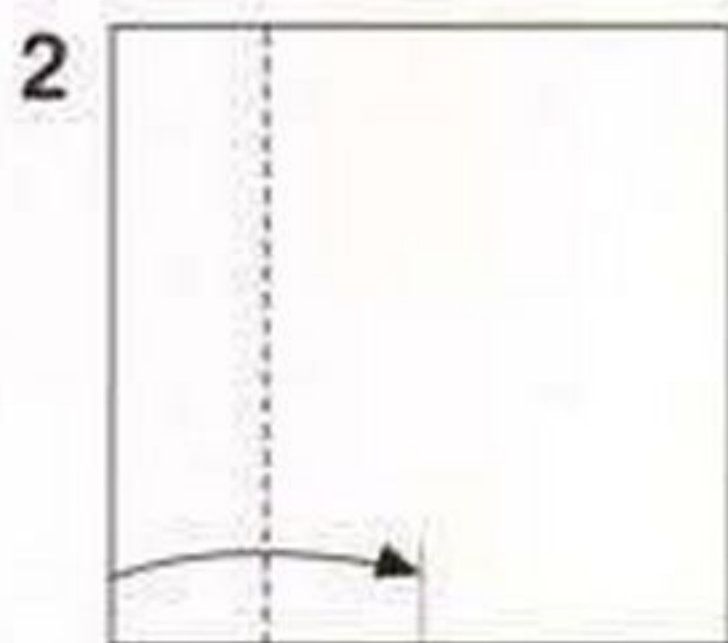

Fold on the crease  $\Delta$  to join the spots marked by the two circles.

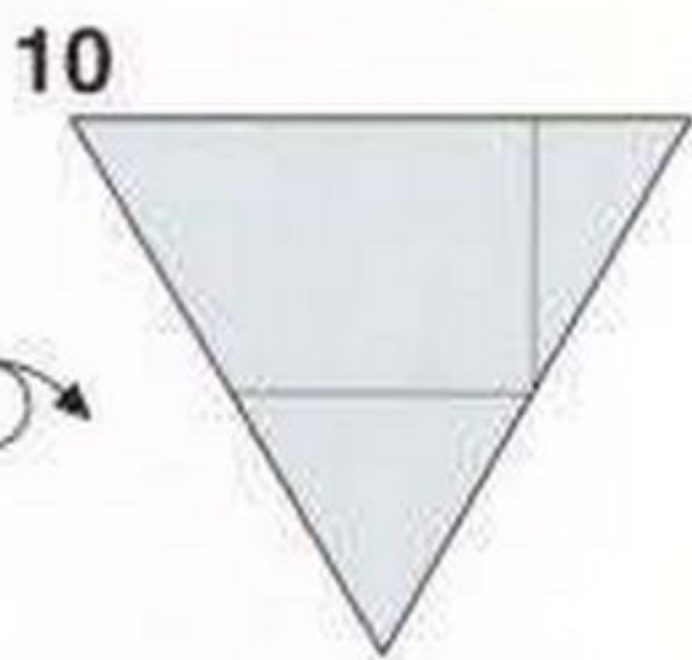
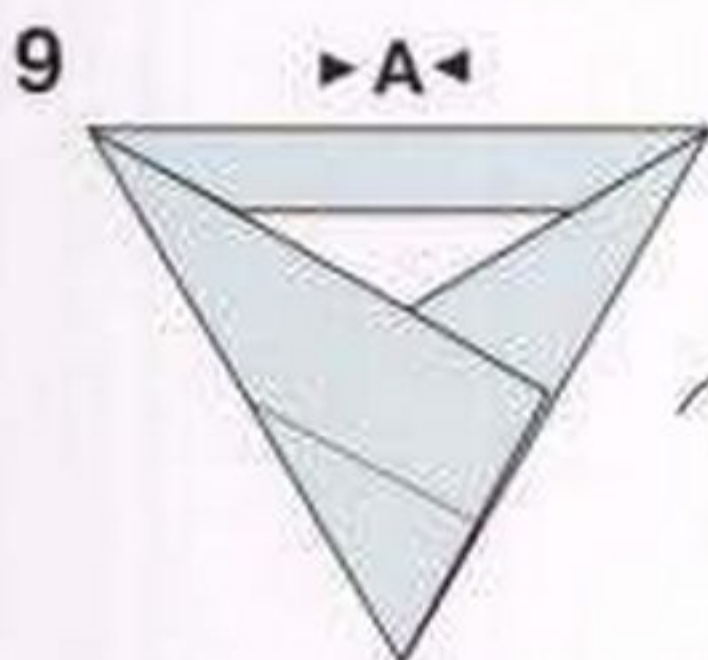
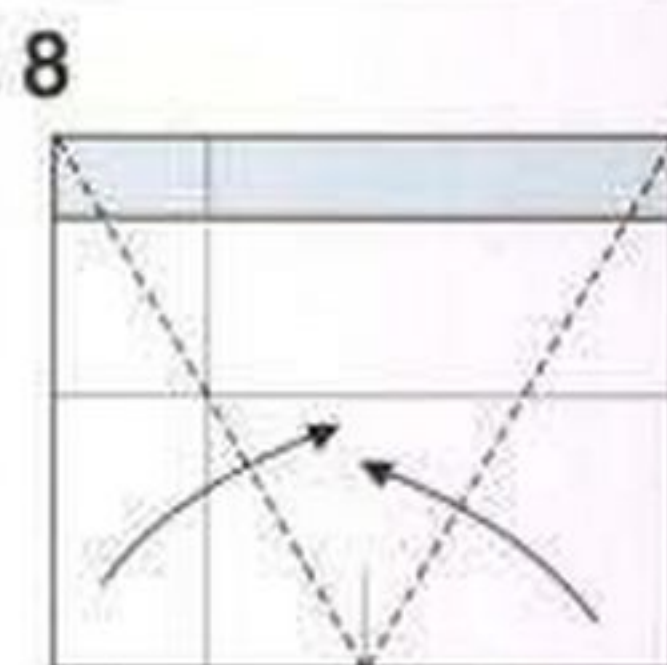
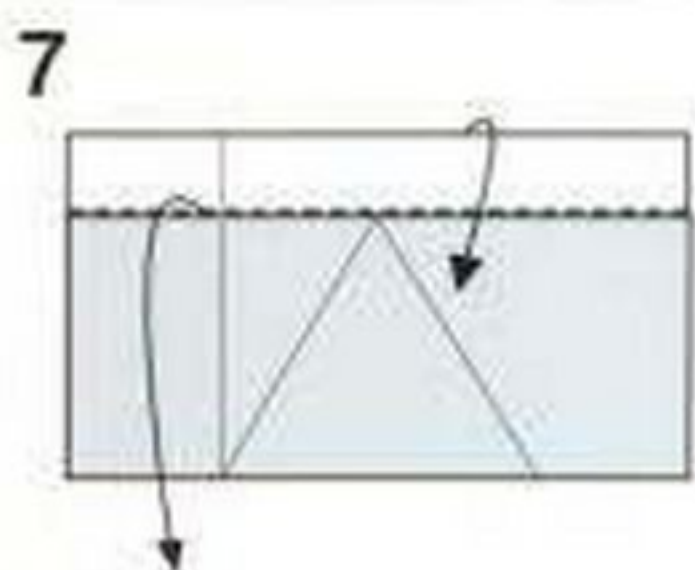
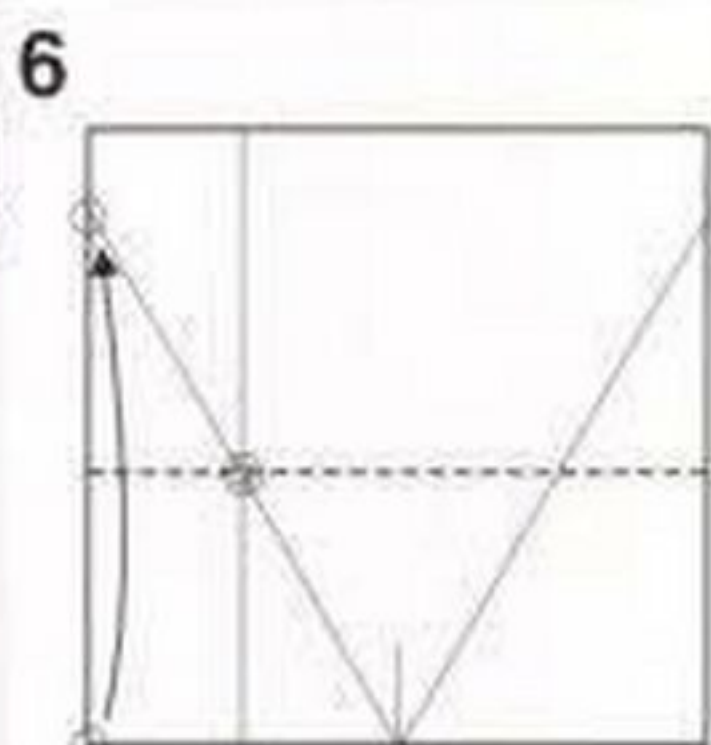
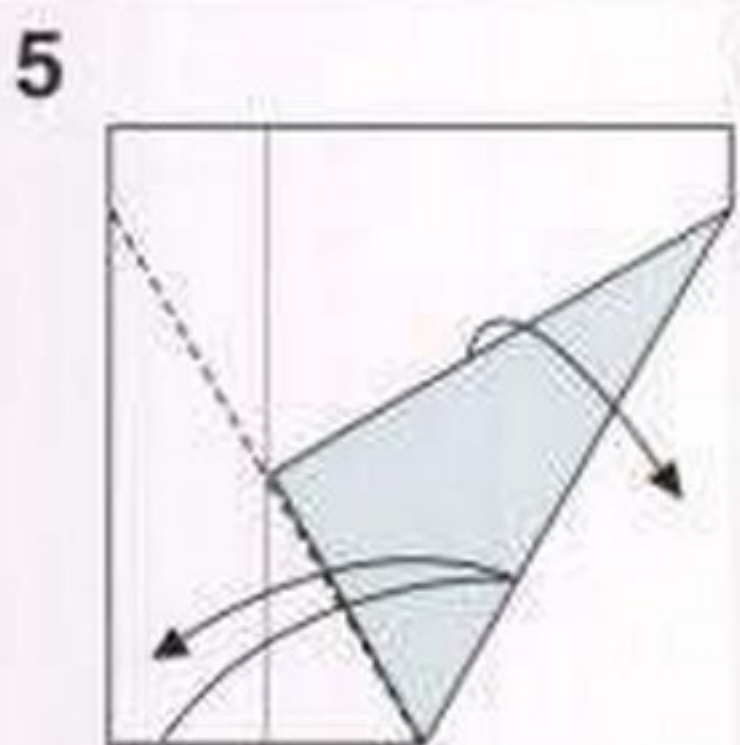
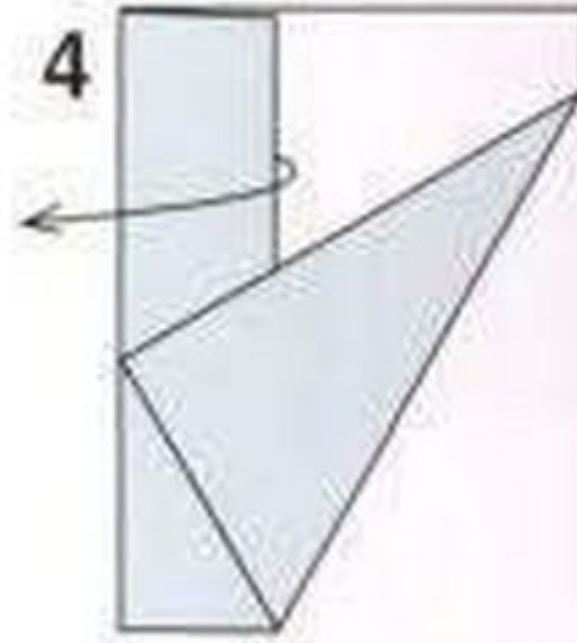

[Assembly Method]

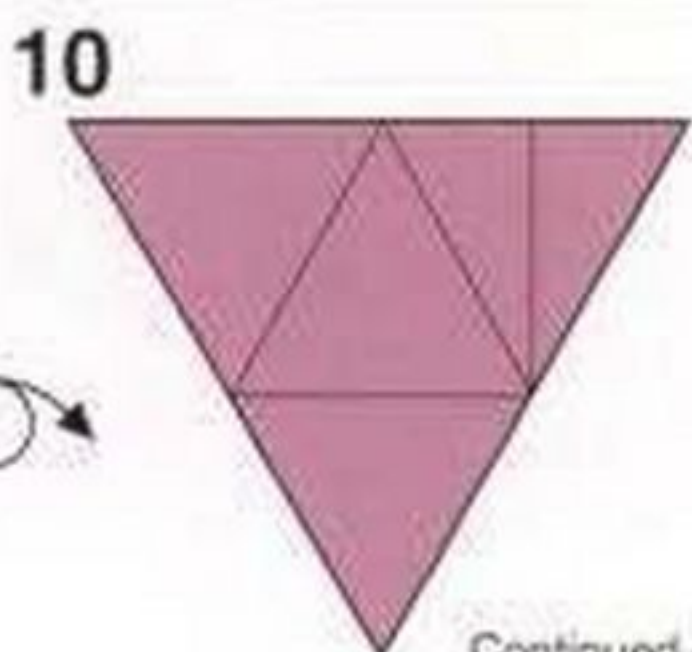
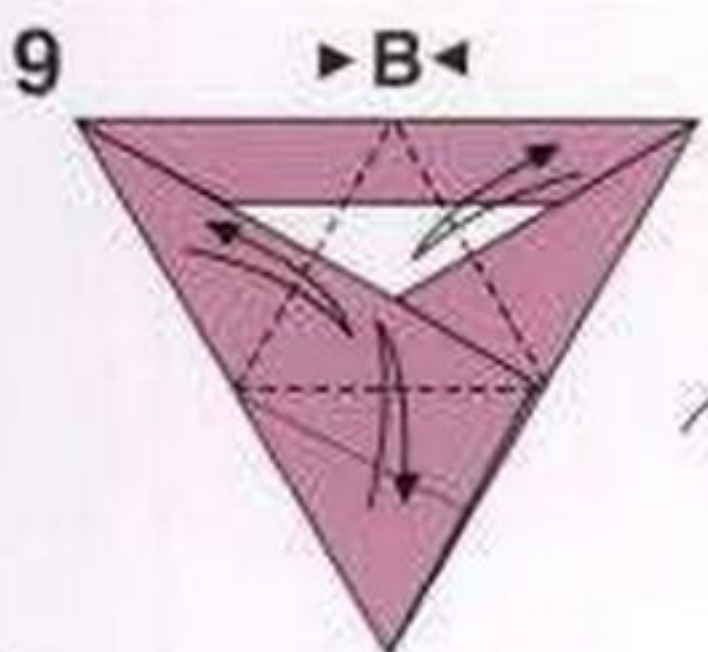
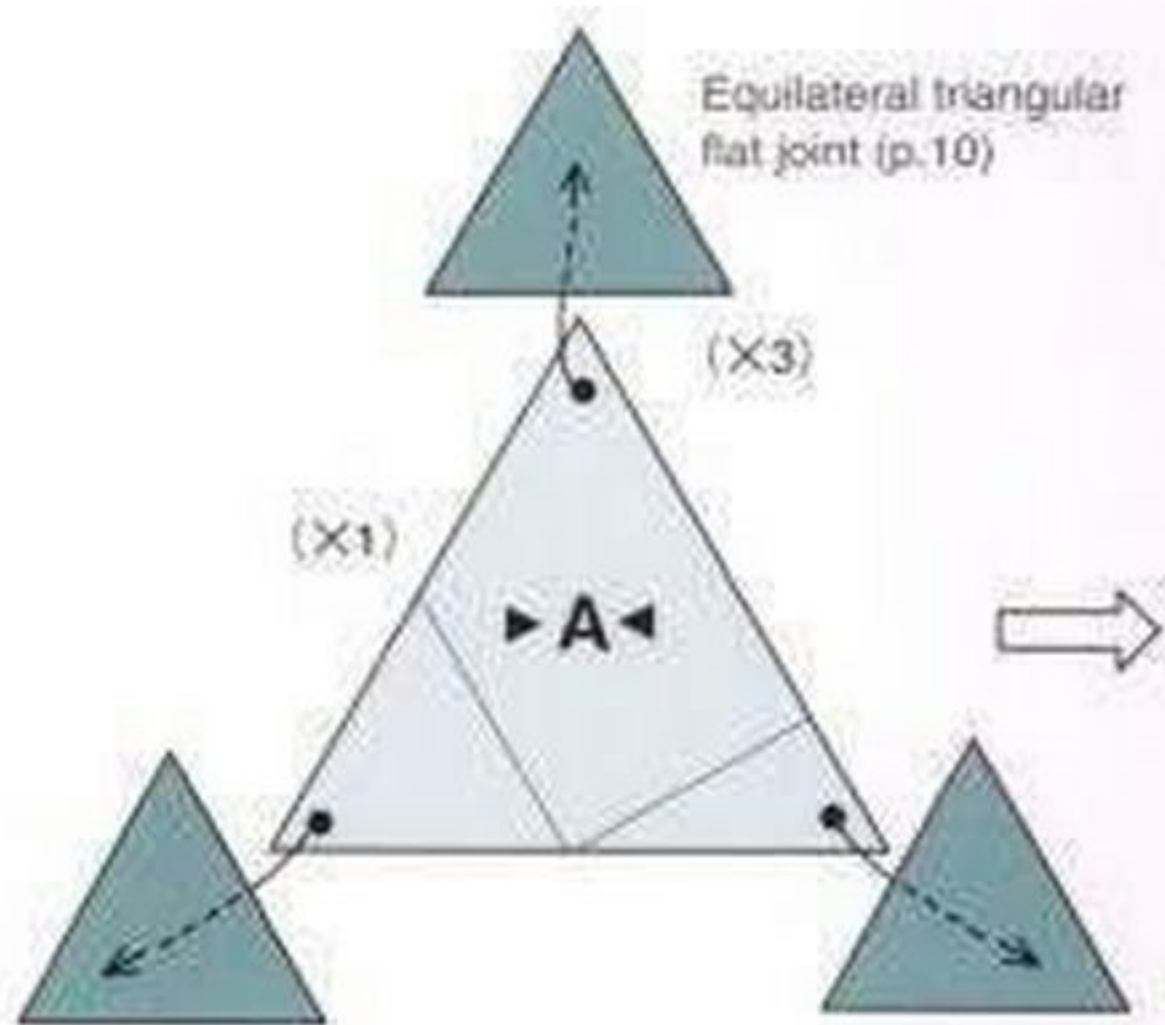

Continued on p.20 and p.21.



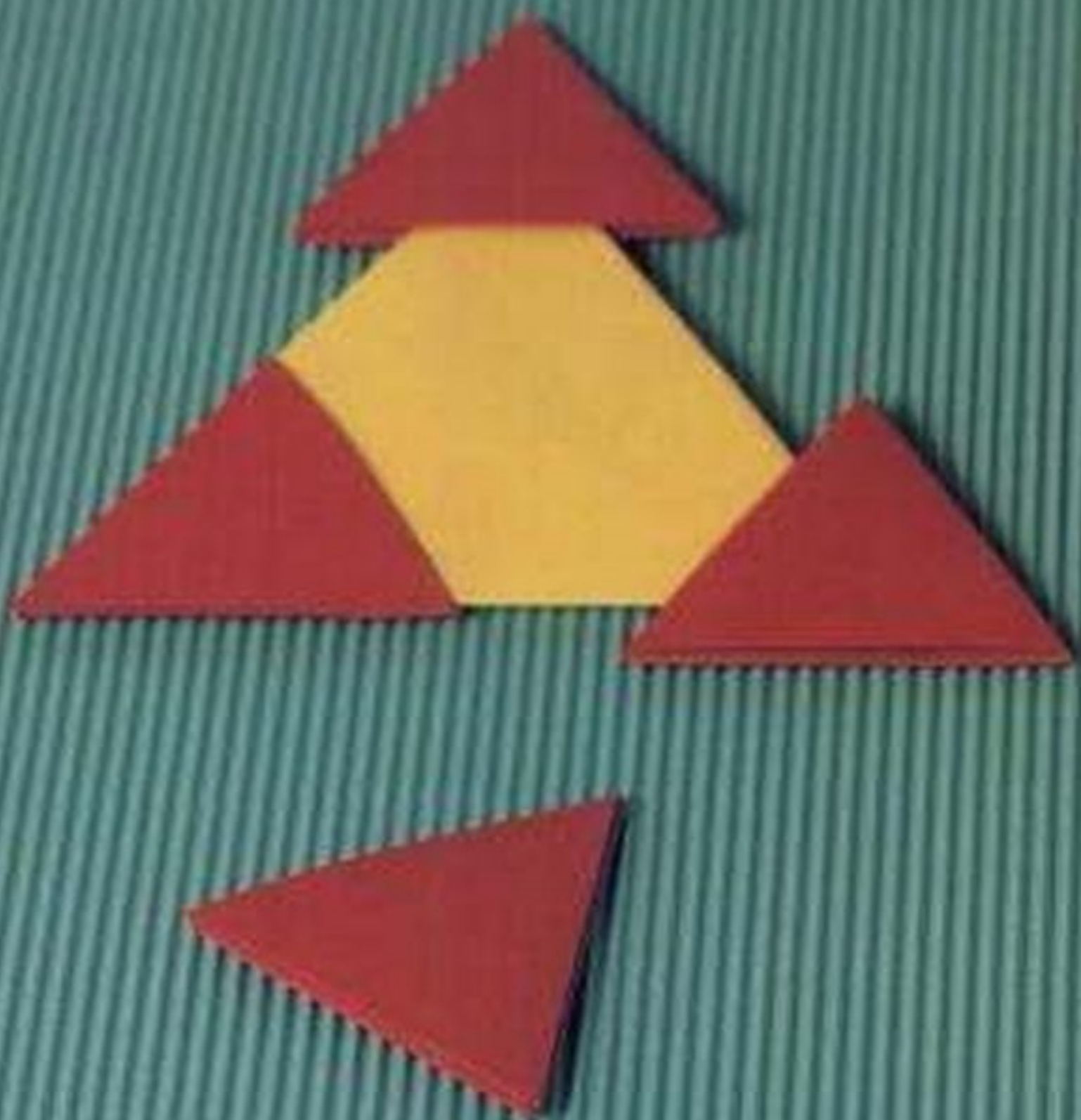

**REGULAR OCTAHEDRON**

A quadruple equilateral triangle is made by combining 1 equilateral triangular element and 3 equilateral triangular flat units.

(Quadruple equilateral triangle) Use 7.5 cm x 7.5 cm paper.  
Treat this as 1 triangle.

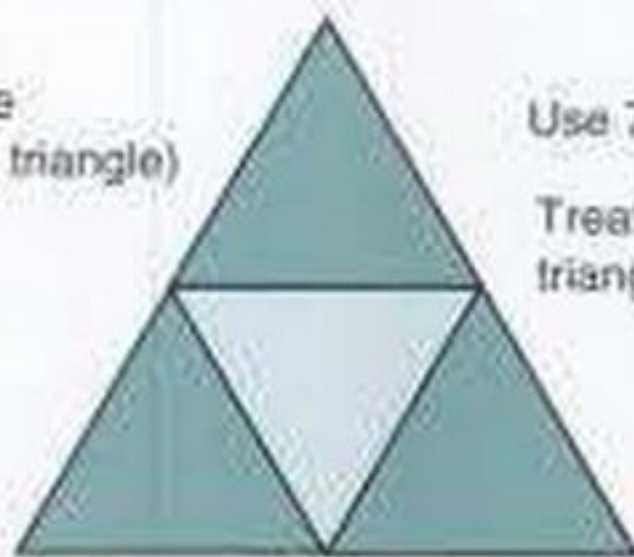

Quadruple equilateral triangle



Joint B



Regular tetrahedron	(X4)	(X12)
Regular octahedron	(X8)	(X24)
Regular icosahedron	(X20)	(X60)

[Assembly Method]

Joint B (p.11)

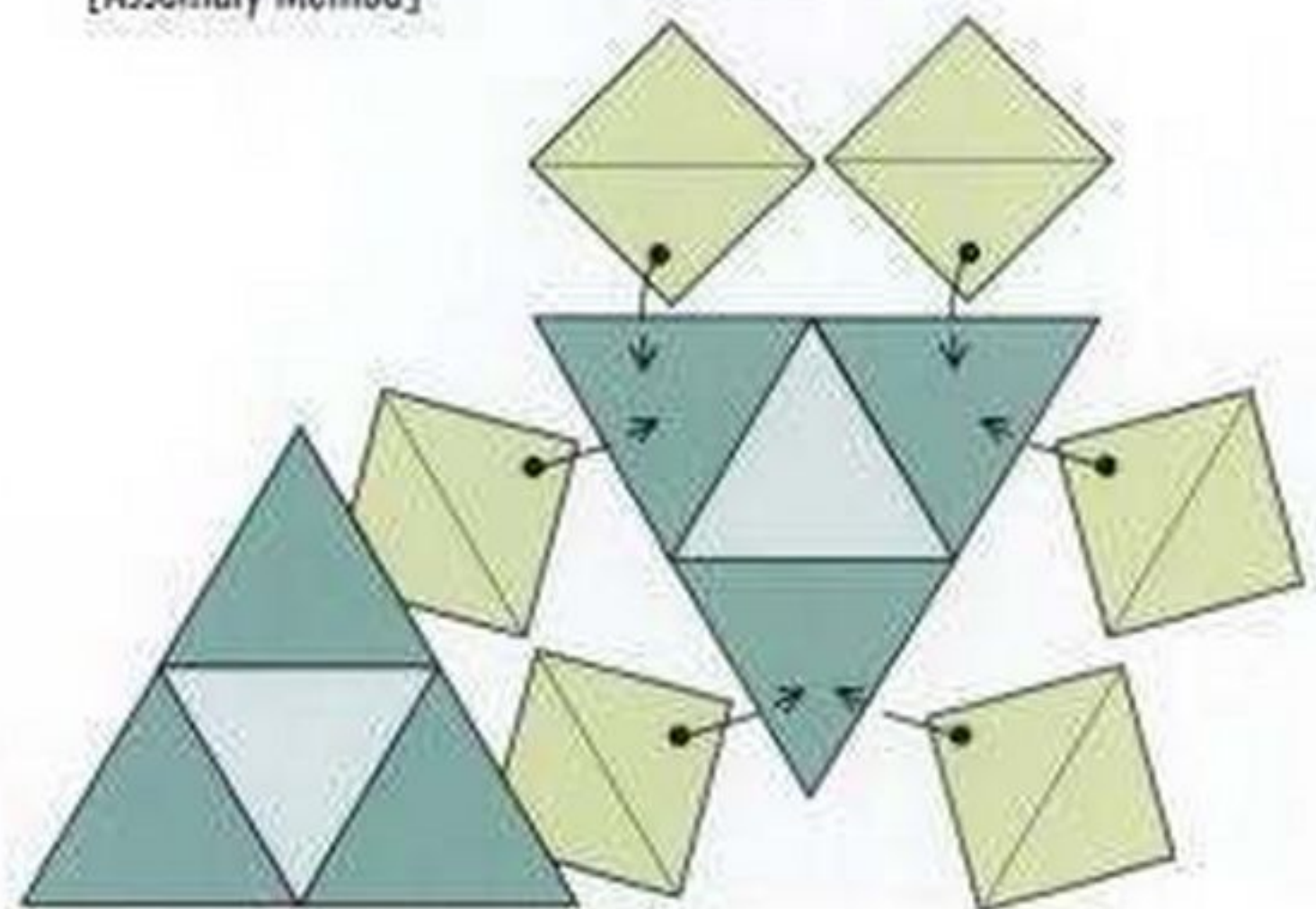



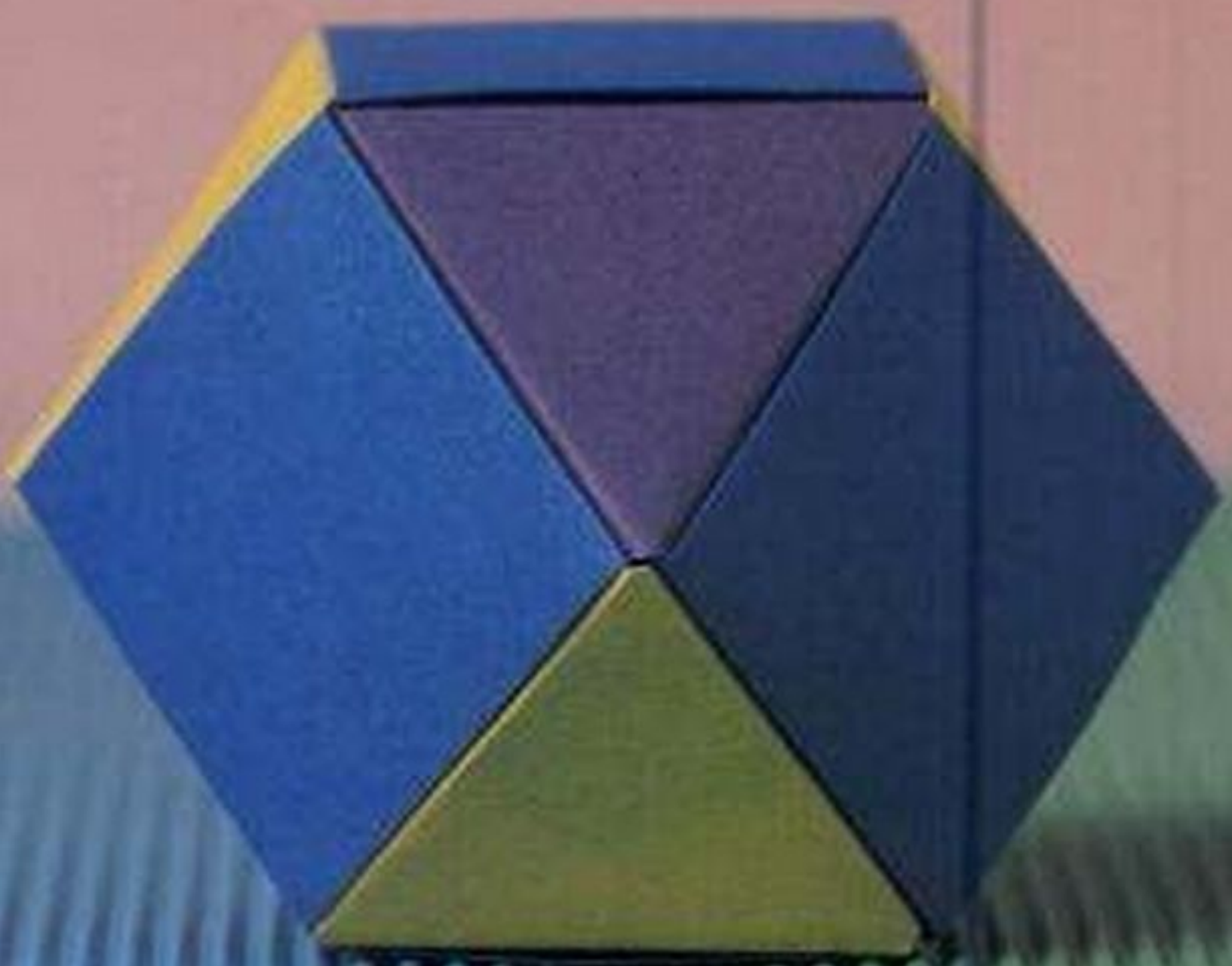

Square flat unit (p.8)



(X8)

Equilateral Triangular  
Element B (p.18)

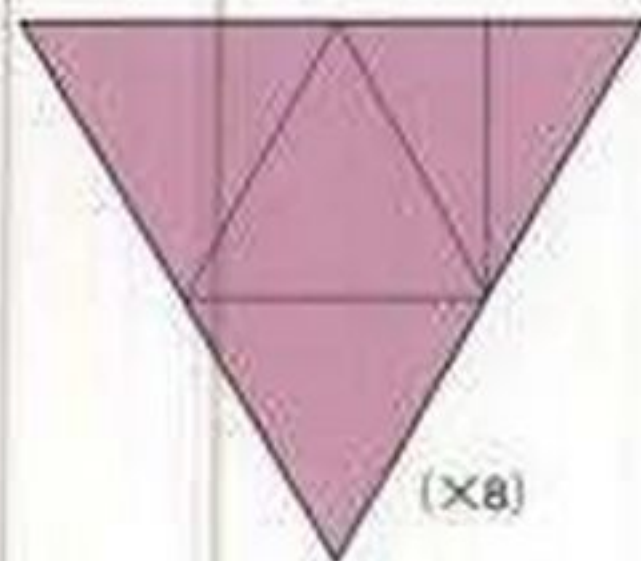

(X8)



Assemble  
like this.

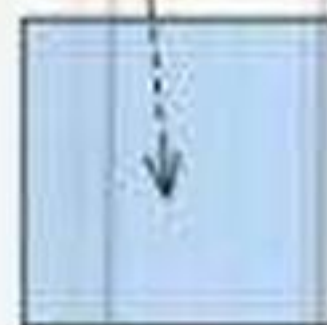

Cuboctahedron



△ X8 □ X6

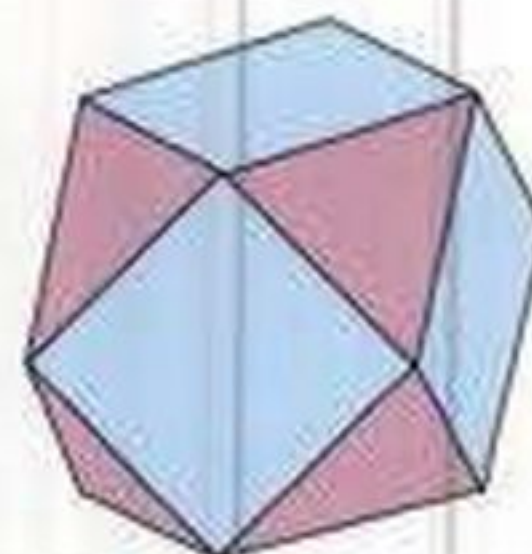



Square flat unit (p.8)



(×120 : 240 sheets of paper)

5 inside rings of square flat units (orange)  $5 \times 12 = 60$   
 2 outside square flat units (blue)  $2 \times 30 = 60$

Joint B (p.11)



(×90)

5 inside square flat units  $5 \times 12 = 60$   
 2 outside square flat units 30

Equilateral triangular  
 element B (p.18)

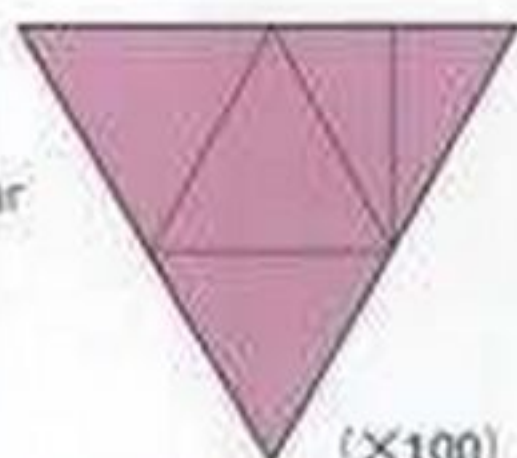

(×100)

Inside triangles (yellowish green) 20  
 Outside star-shaped triangles (yellow)  $5 \times 12 = 60$   
 Exterior triangles (purple) 20

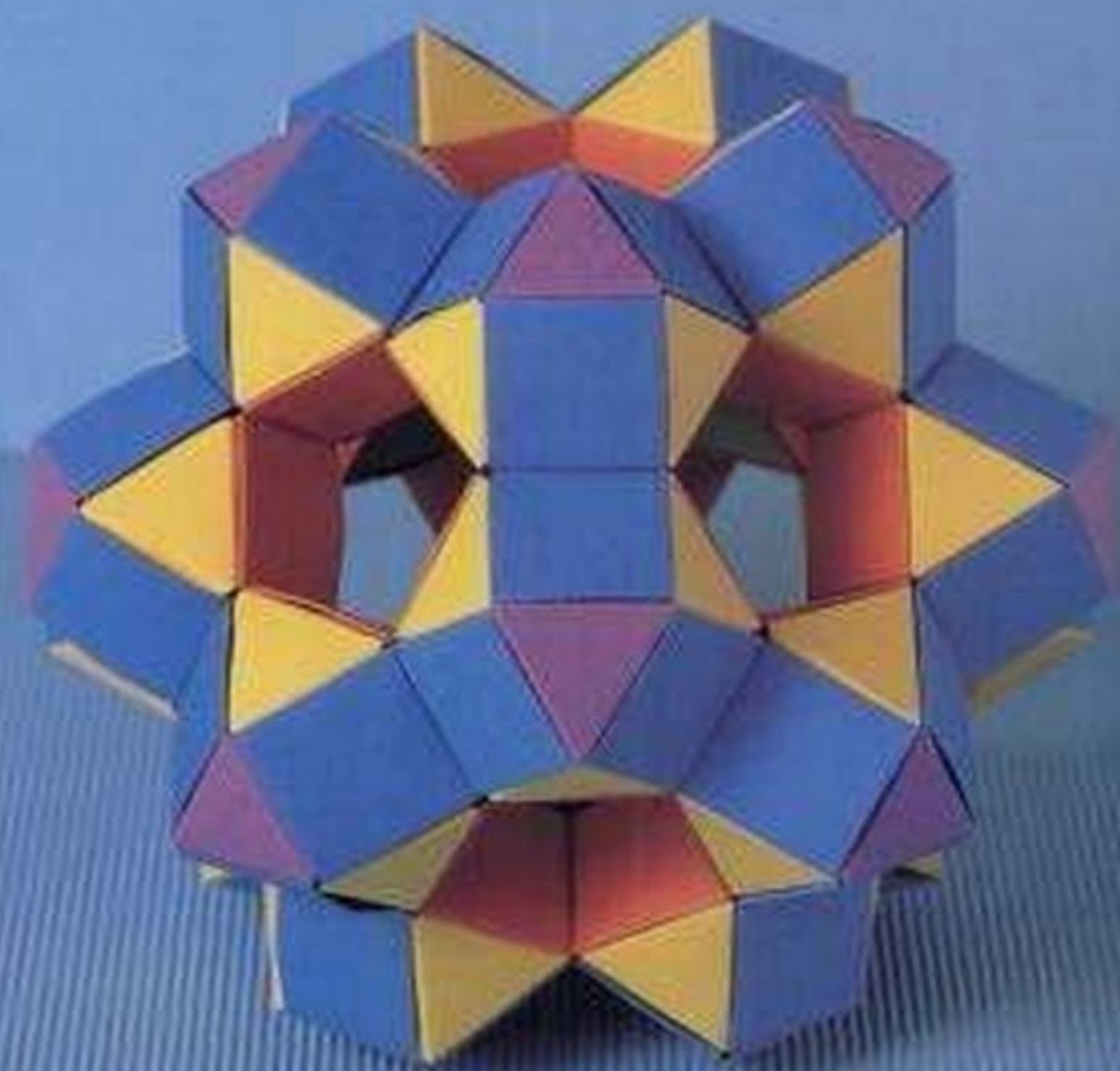
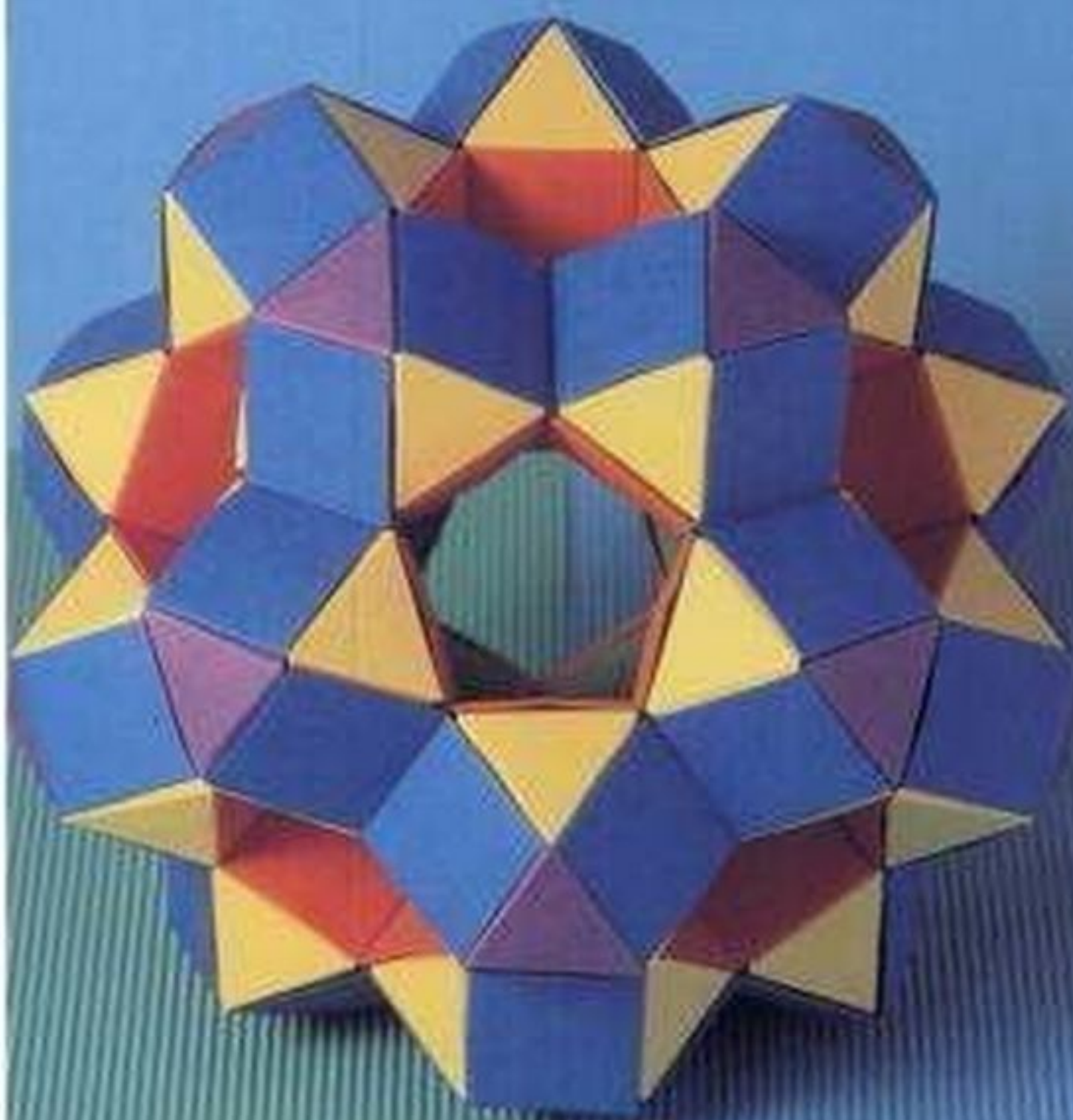



# 3

## A VARIETY OF REGULAR DODECAHEDRONS

Surface patterns depend on the number of dodecahedrons used. It is possible to assemble them with 60 or 120 rhomboid units.

**VARIANT KUSUDAMA DODECAHEDRON** /p.30



**RHOMBIC CUBOCTAHEDRON,  
DODECAHEDRON AND:  
MADE WITH 120 RHOMBOID UNITS** /p.29

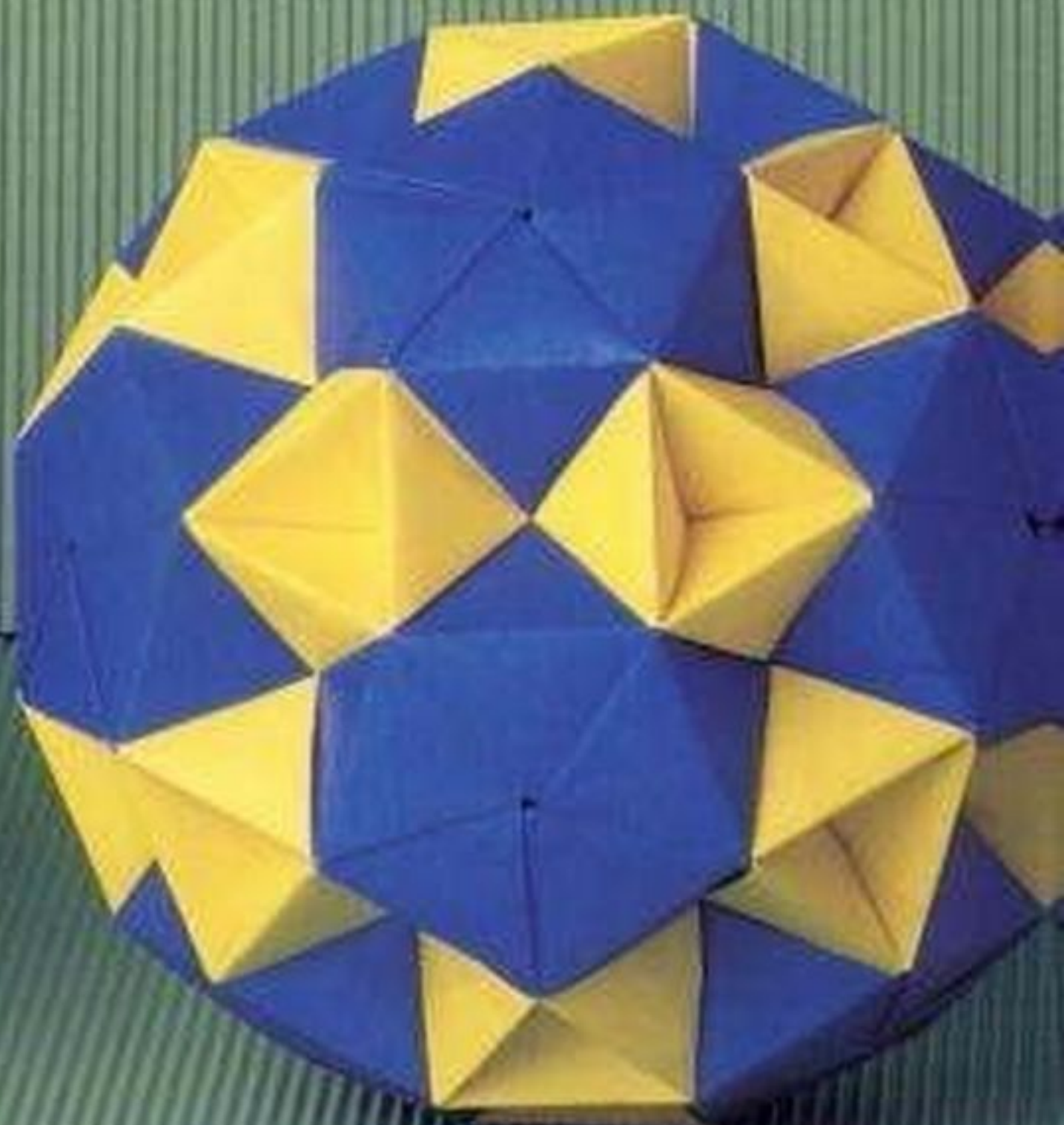

**KUSUDAMA DODECAHEDRON** /p.30



**REGULAR ICOSAHEDRON:  
MADE WITH 30 RHOMBOID UNITS /p.26**



**12 REGULAR  
DODECAHEDRONS /p.24**



**ICOSAHEDRON, DODECAHEDRON:  
MADE WITH 60 RHOMBOID UNITS /p.28**



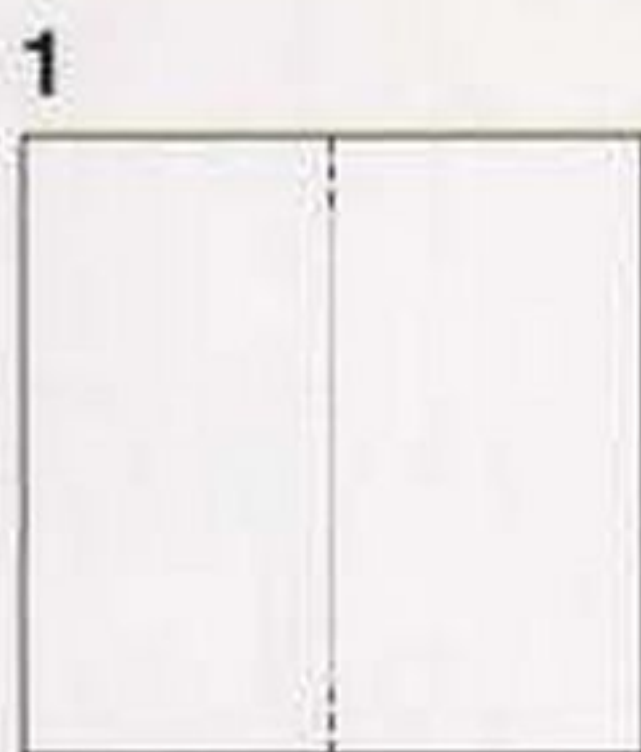

Make short creases on the upper and lower sides.

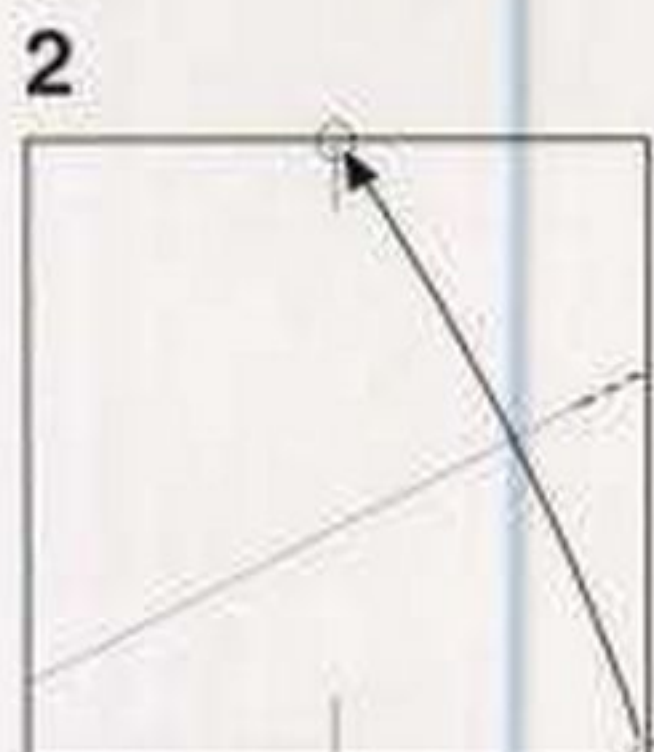

Fold along the line marked by the two circles to make a crease.

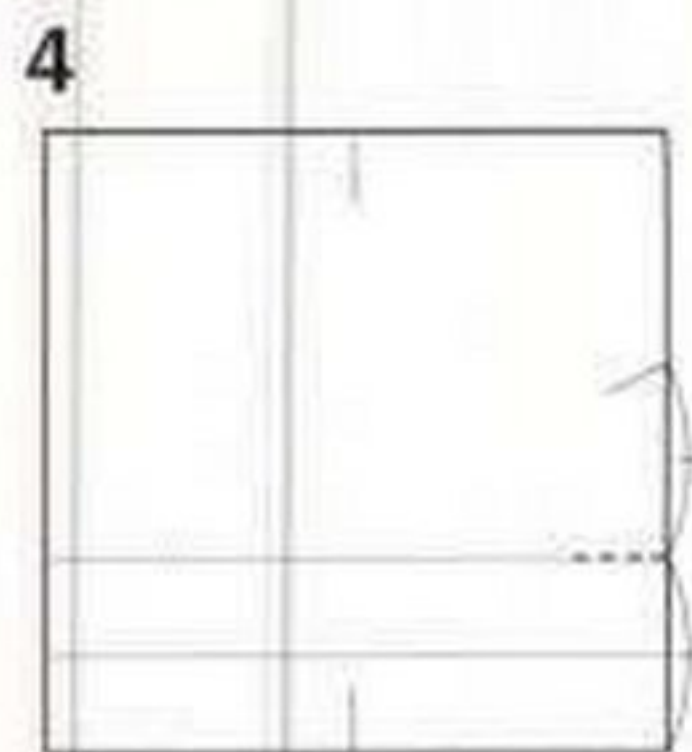
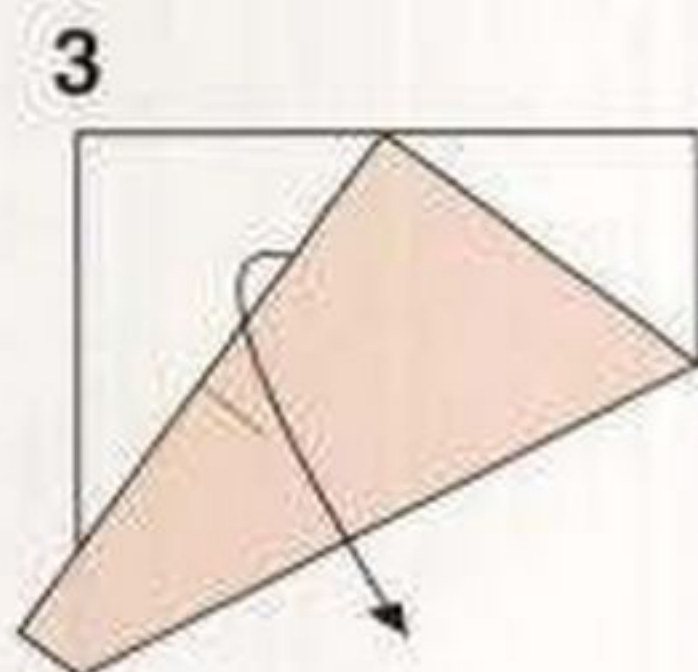

Make a short crease on the right side.

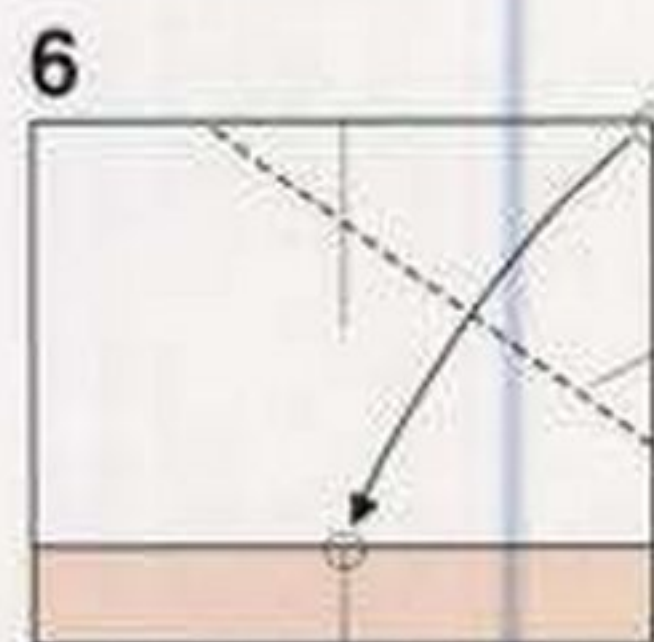
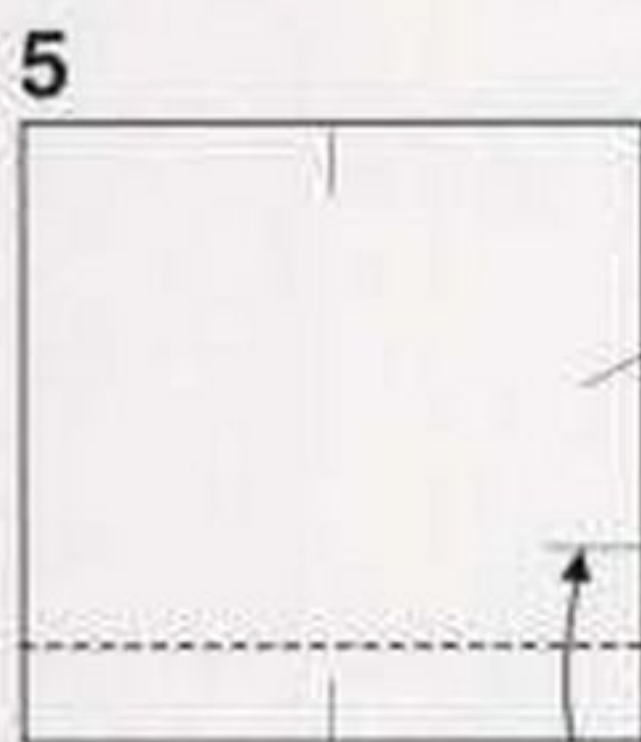

Fold so as to join the two circles ○.

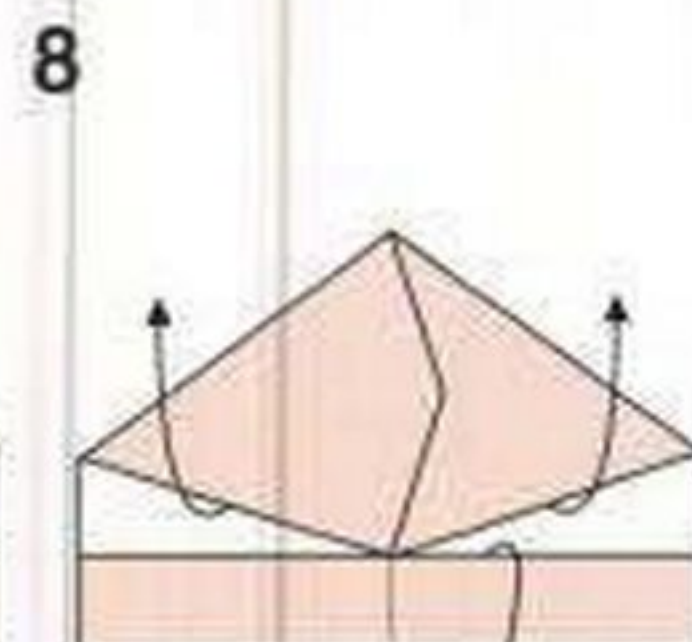
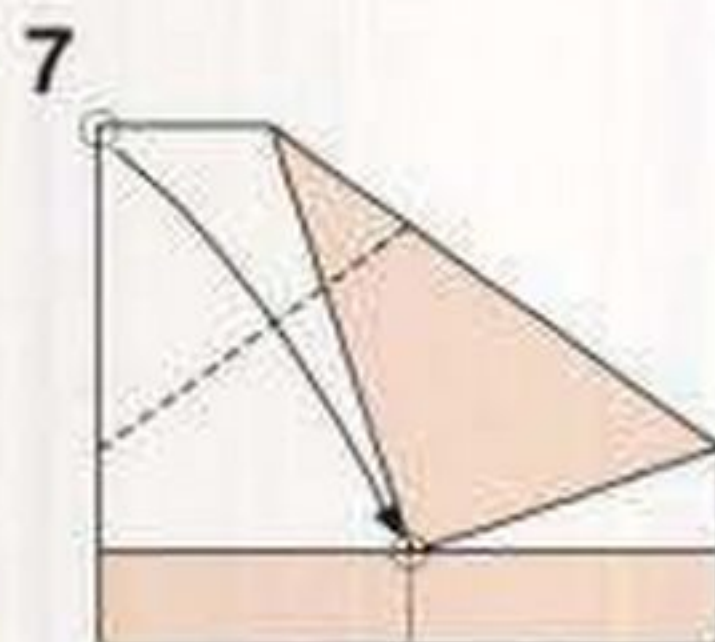

Unfold.

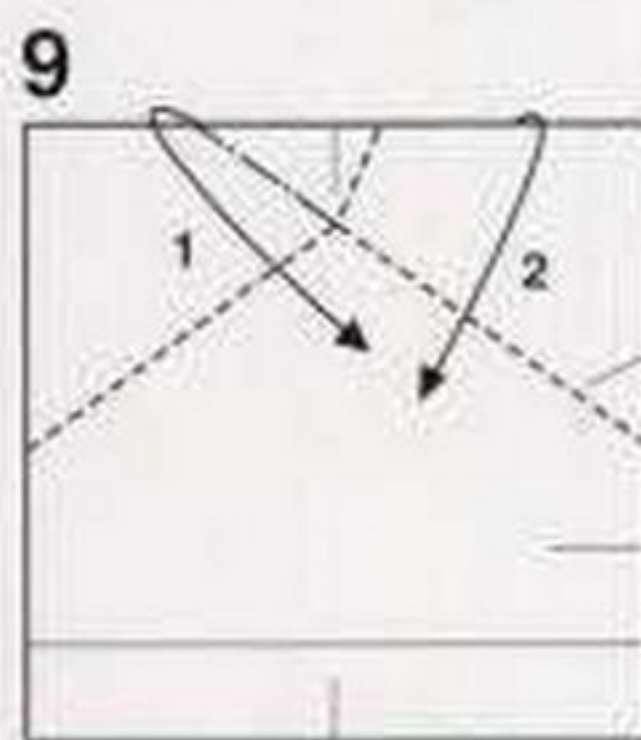

Fold in numerical order.

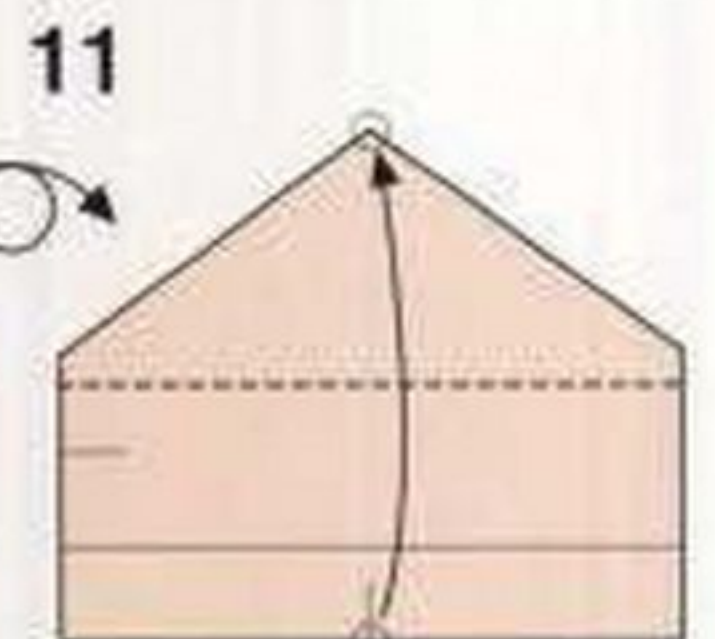
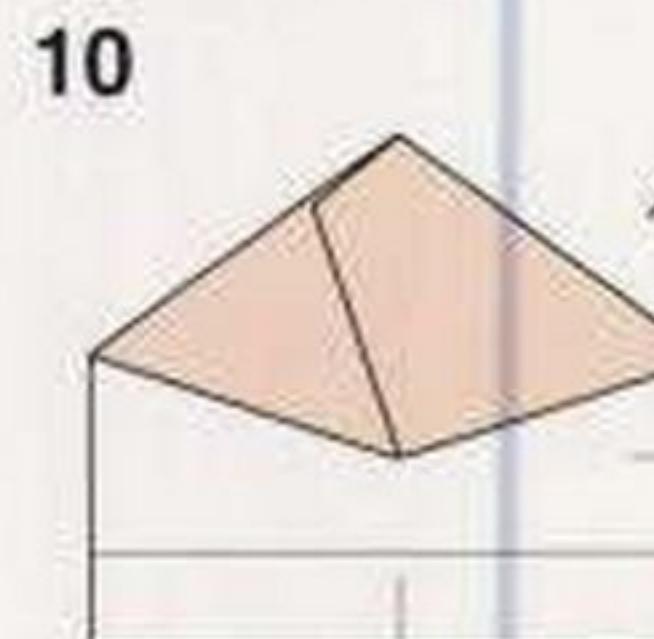

Fold so as to join the two circles ○.



Fold the upper corners down.

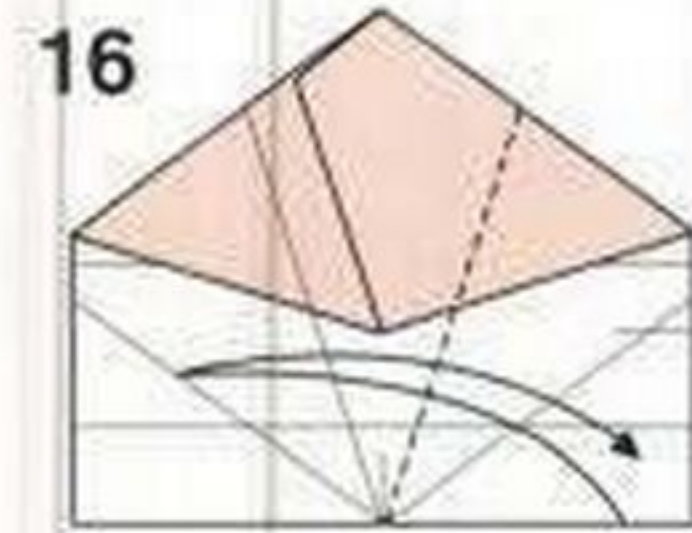
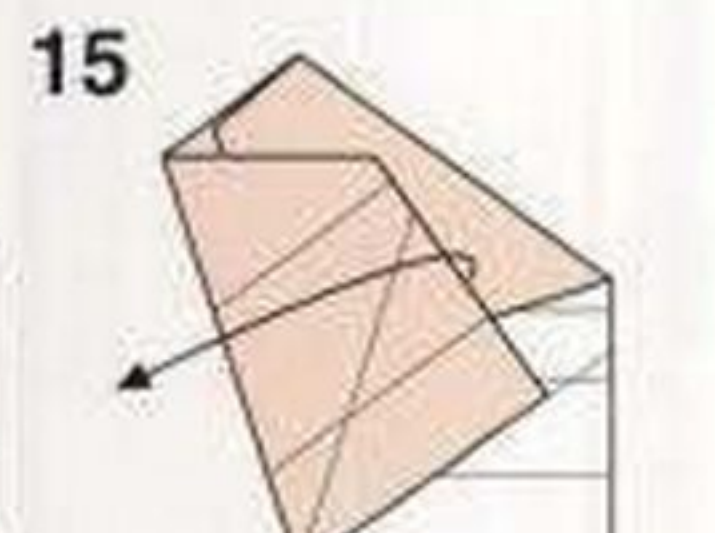
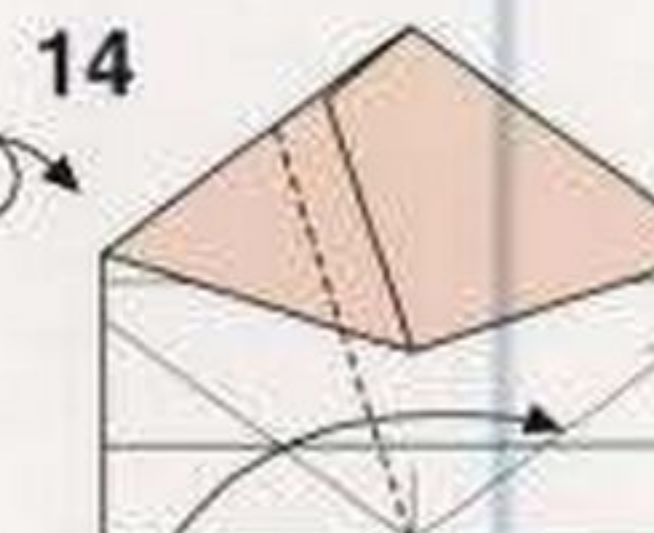
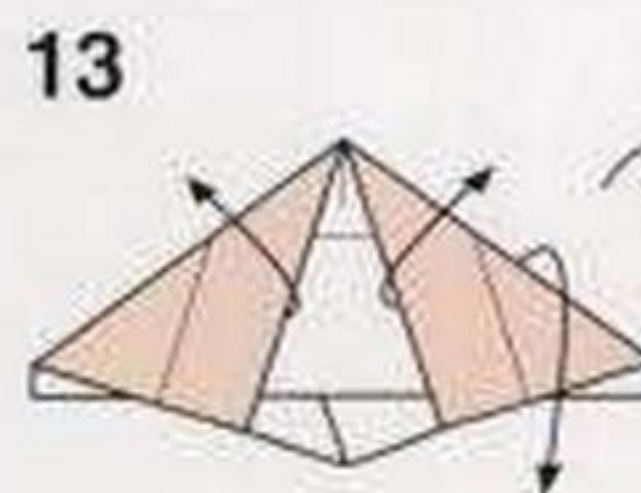

Fold the other side in the same way.

Material com direitos autorais



17

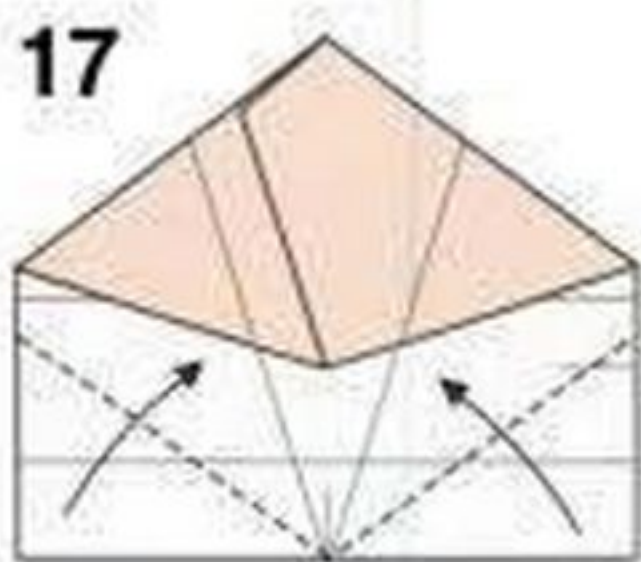

18

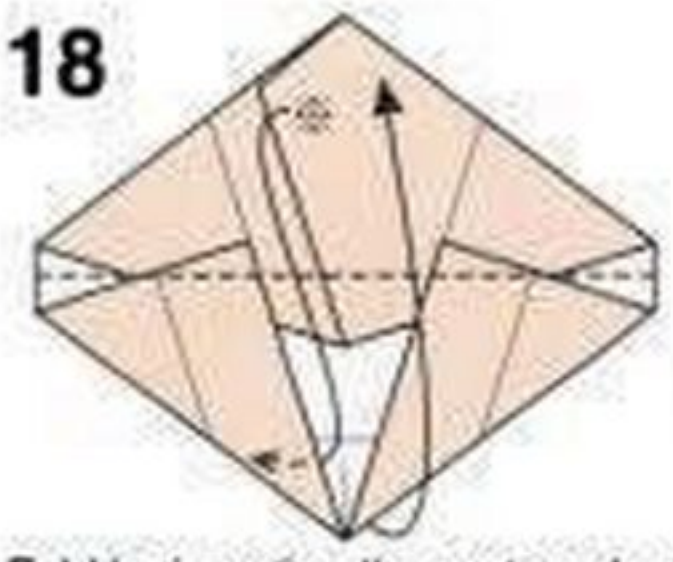

Fold by inserting the part marked with a star ☆ into the pocket.

19

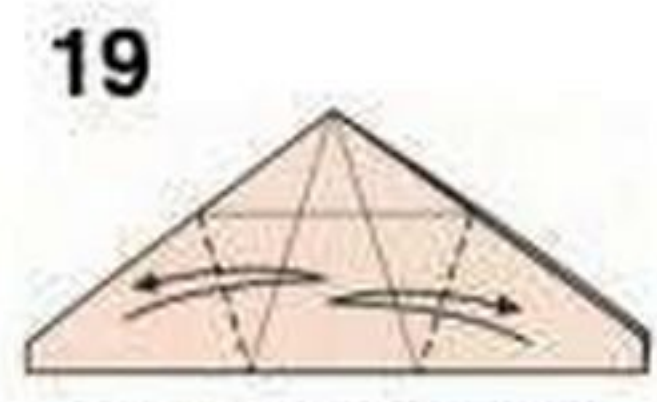

Make creases by aligning edges with the line.

20

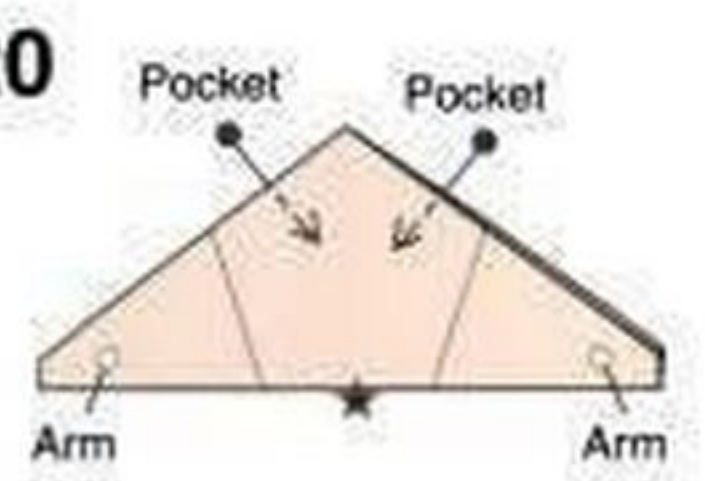

★ is closed.

(X12)

[Assembly Method] Connect by joining the spots marked with stars ★.

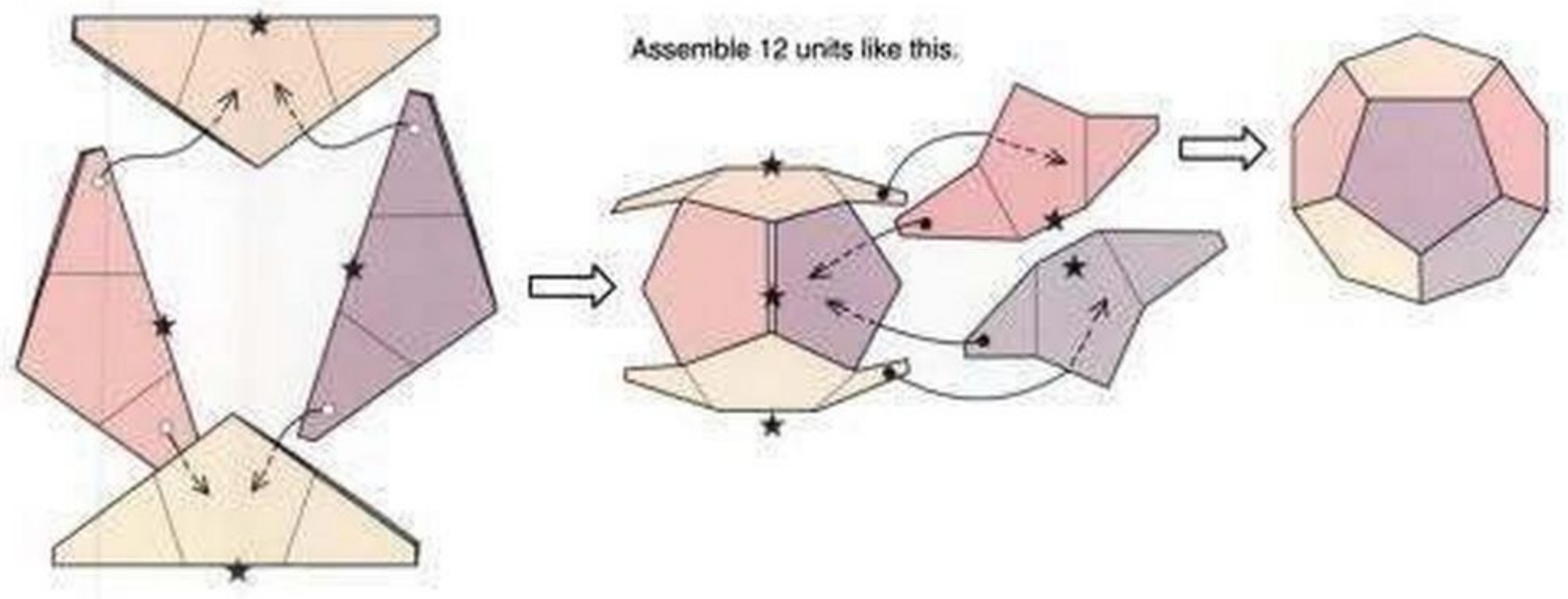

Assemble 12 units like this.





Make a rectangular pattern paper.

Methods 1-3 were worked out by Kazuo Haga.

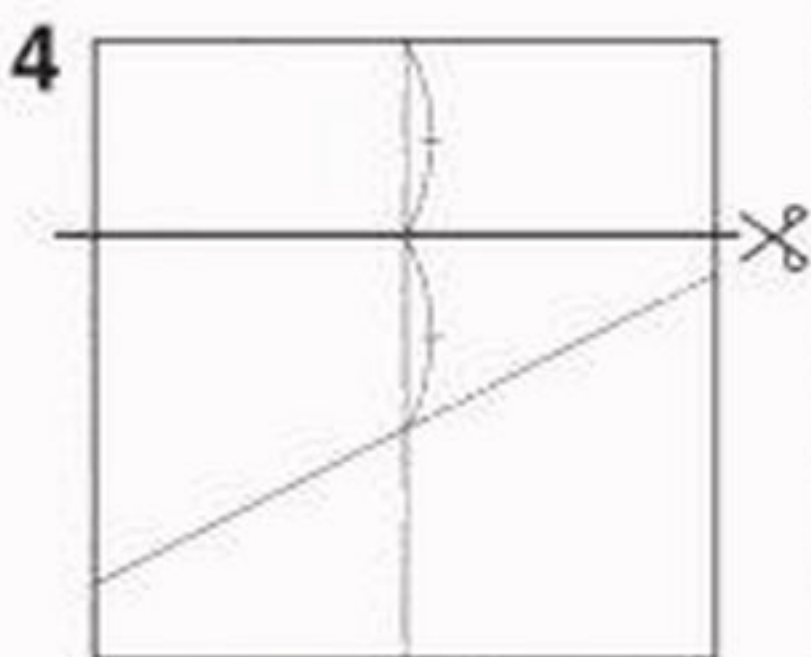
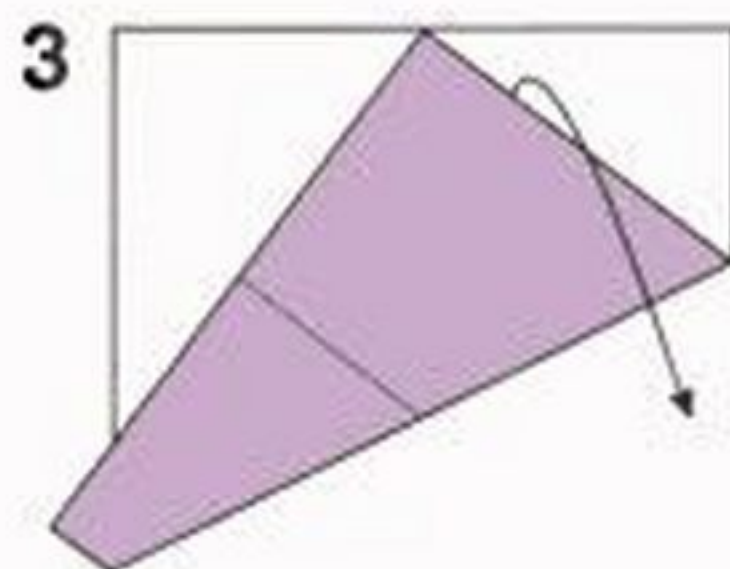
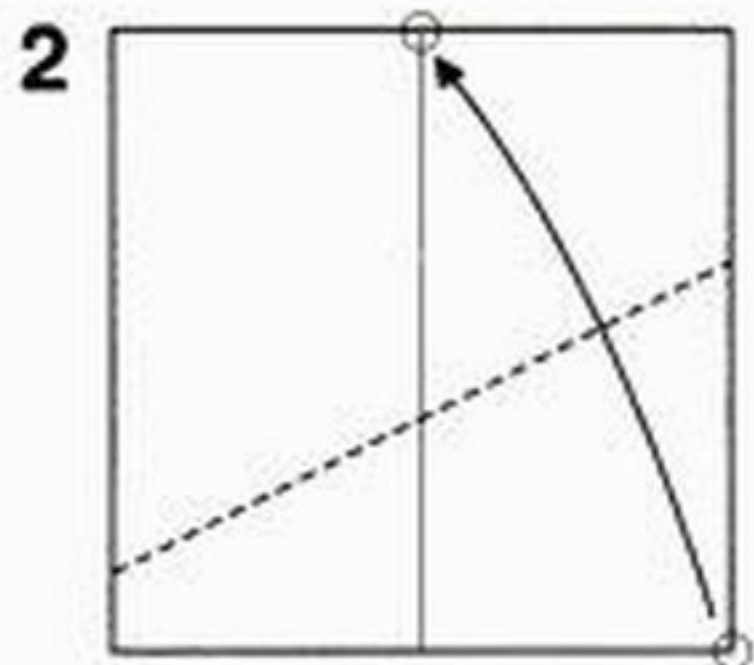
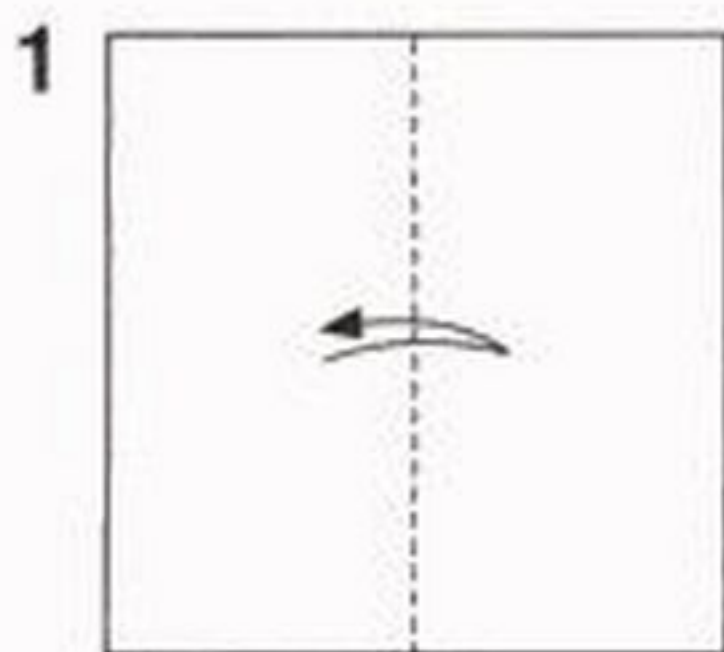

**5**  
[Pattern paper]

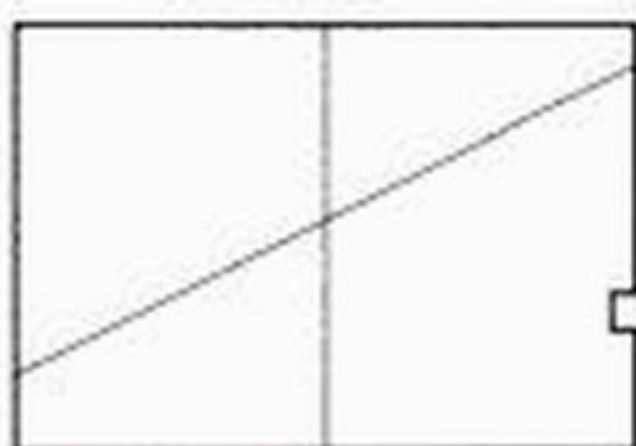

Put sheets of paper on top.

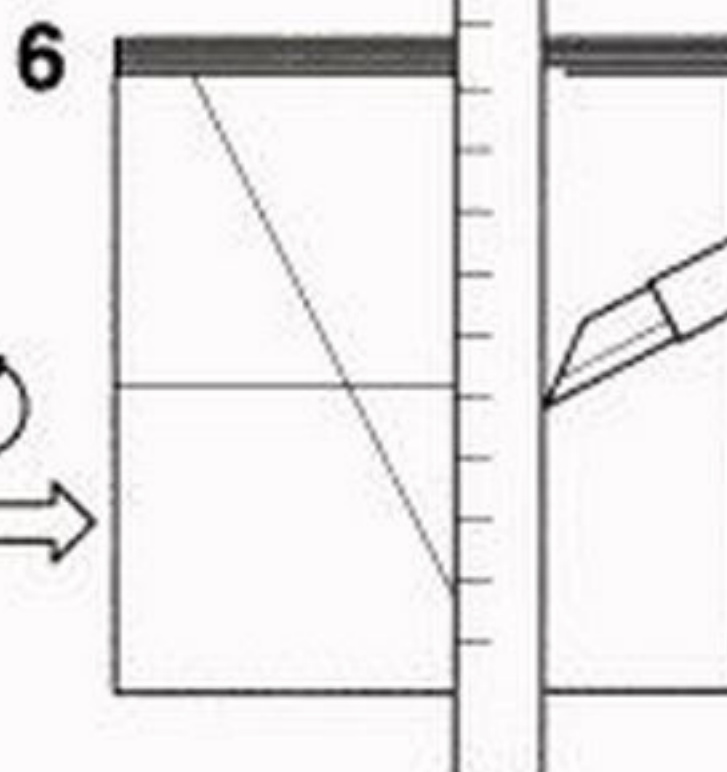

Use a cutter to cut additional sheets according to the pattern.

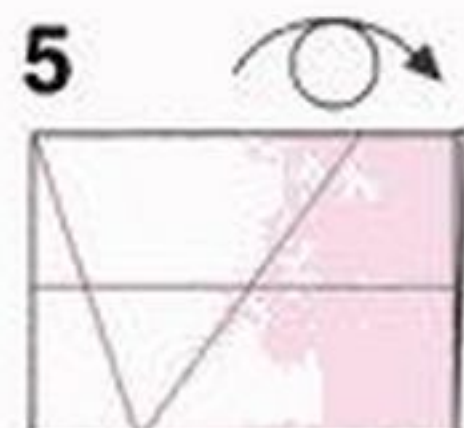
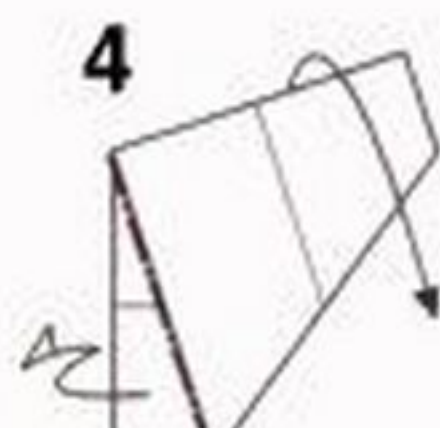
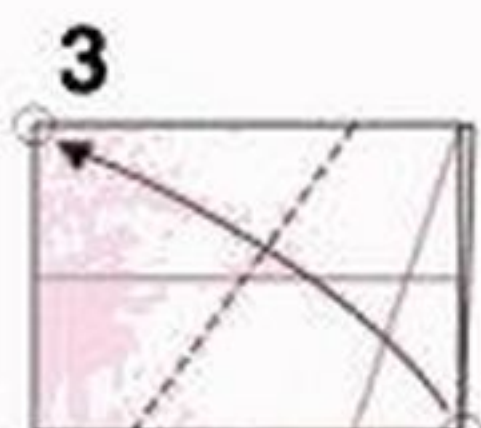
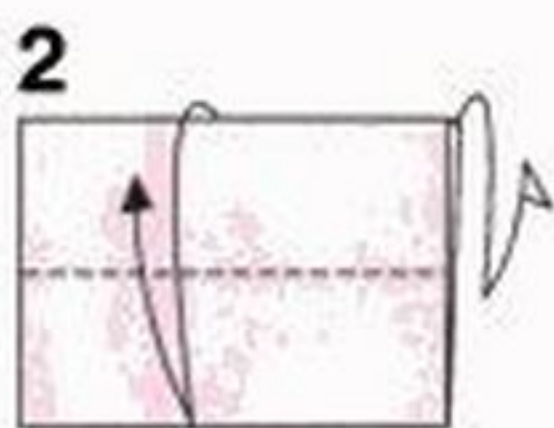
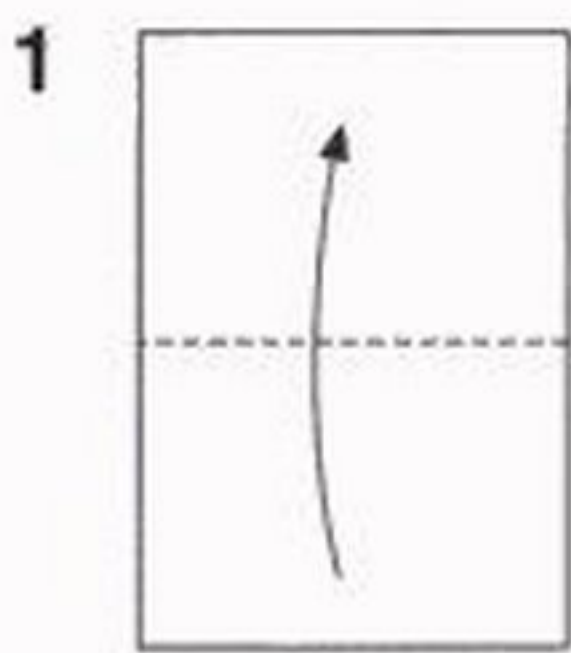

Make creases and unfold.

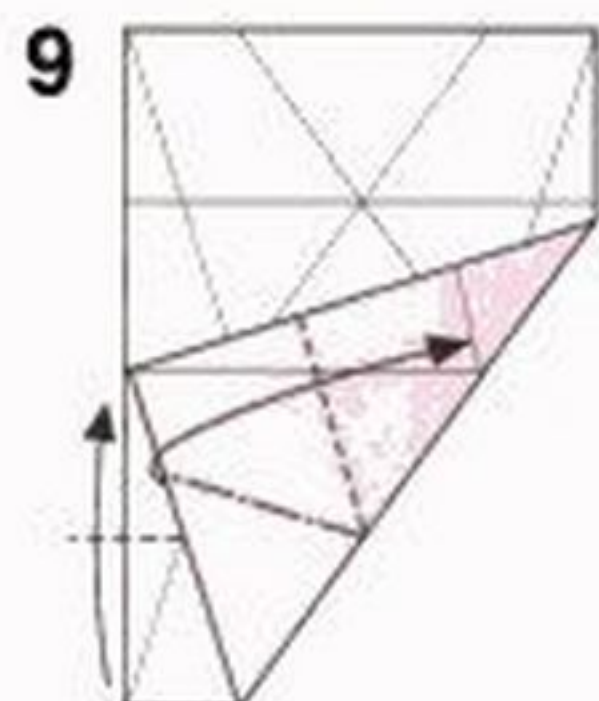
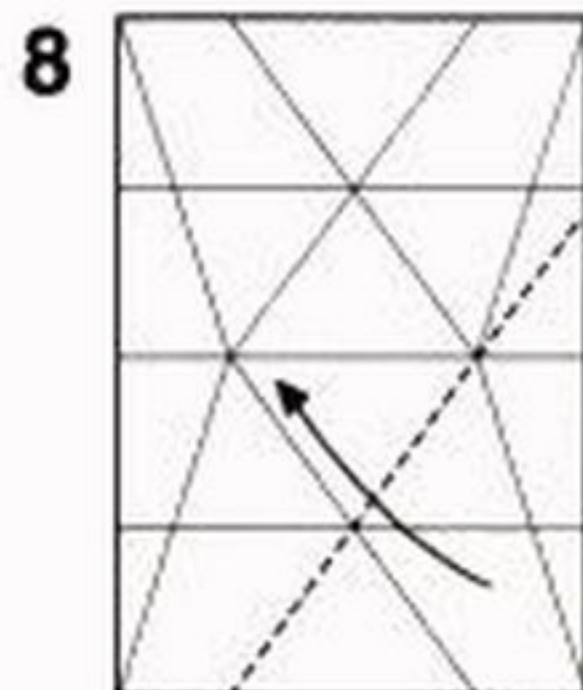
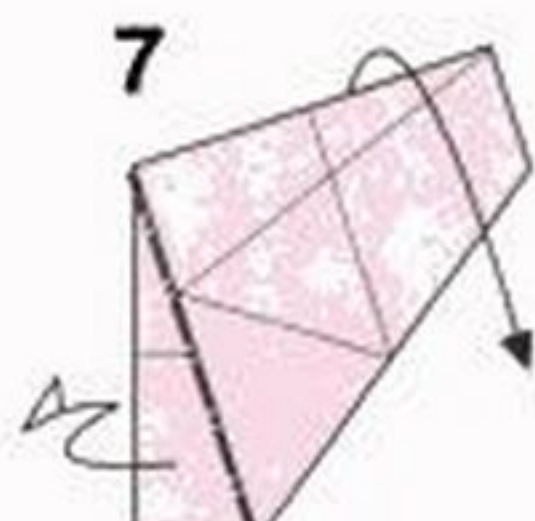
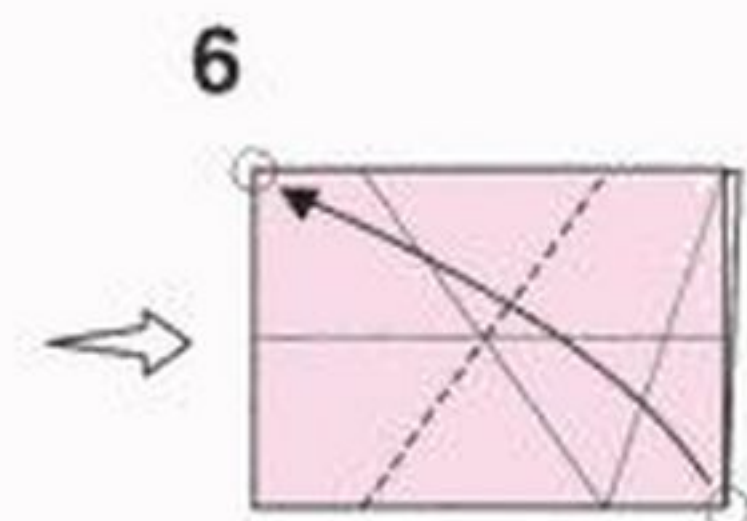



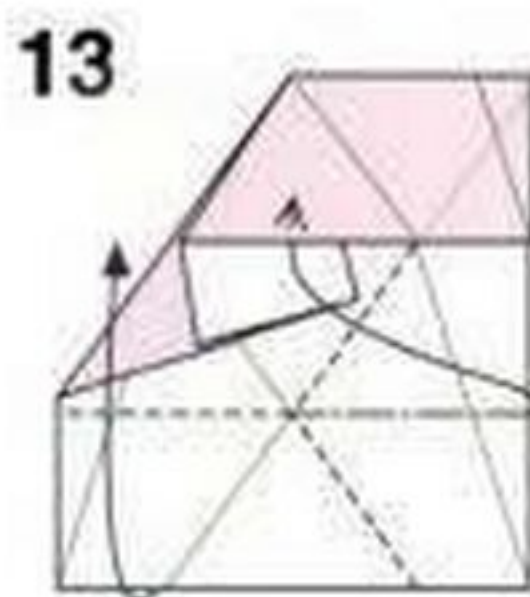
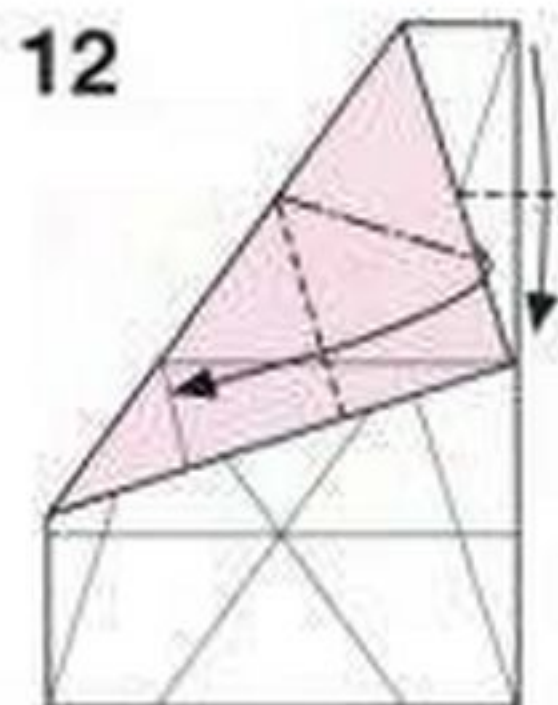
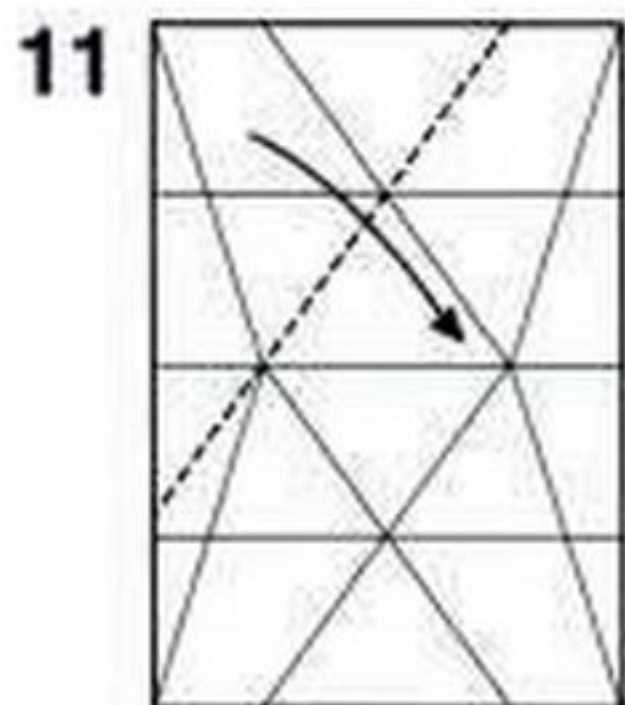
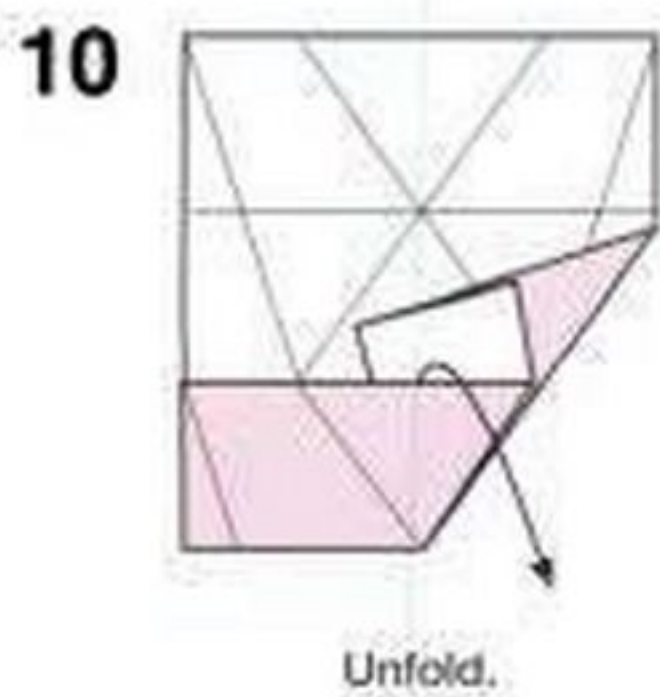

Make creases by folding both edges along the edges as shown below.

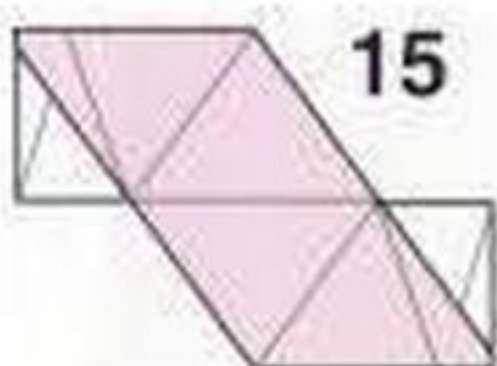

(X30)

[Assembly Method]

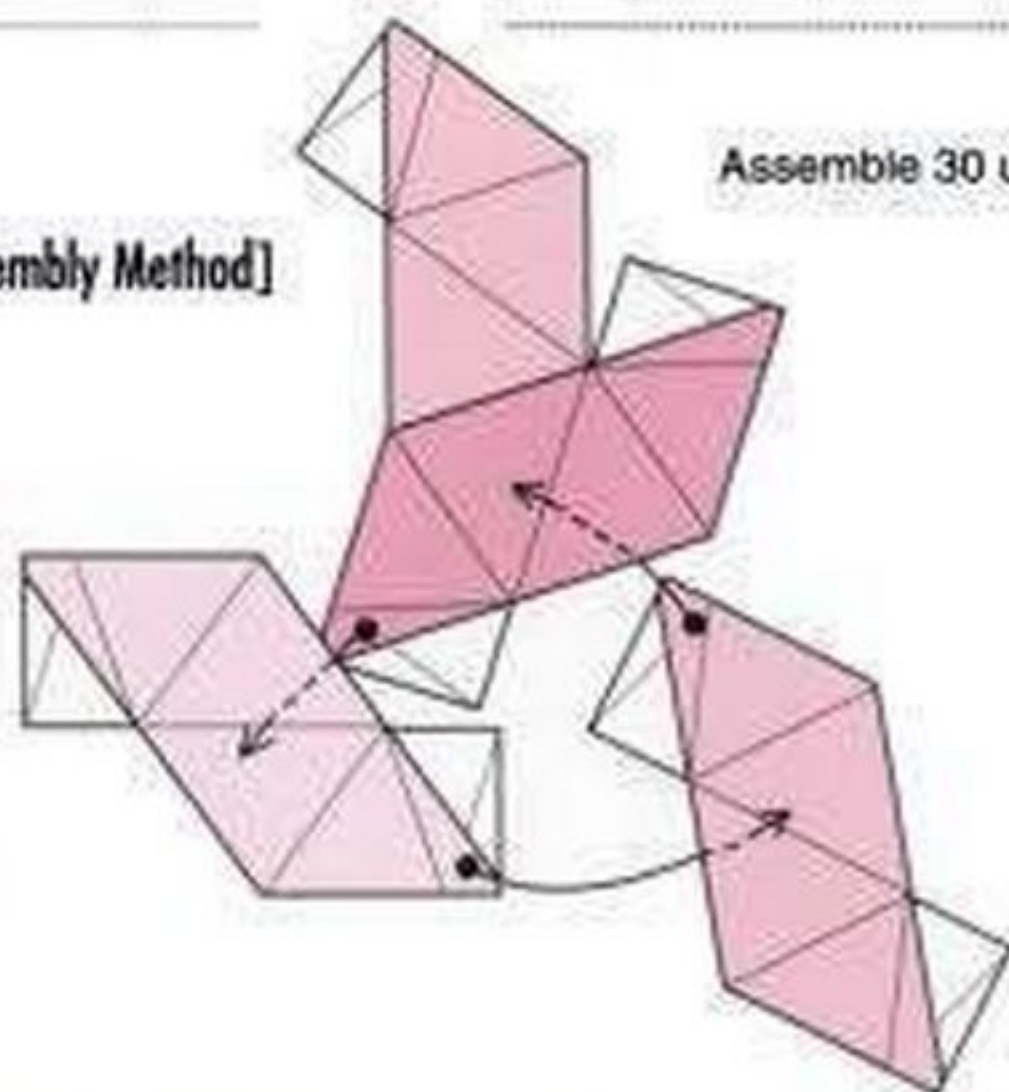

Assemble 30 units like this.

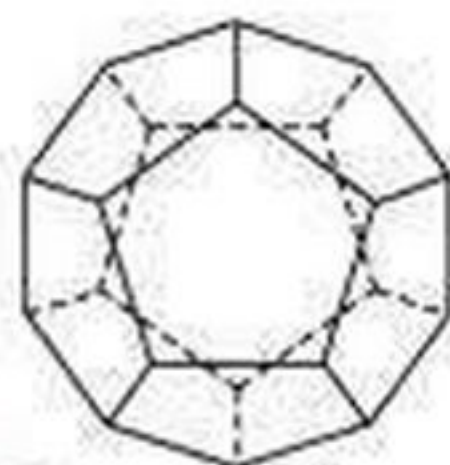

⬠ X12





Rhomboid unit (From step 14 on p.26)

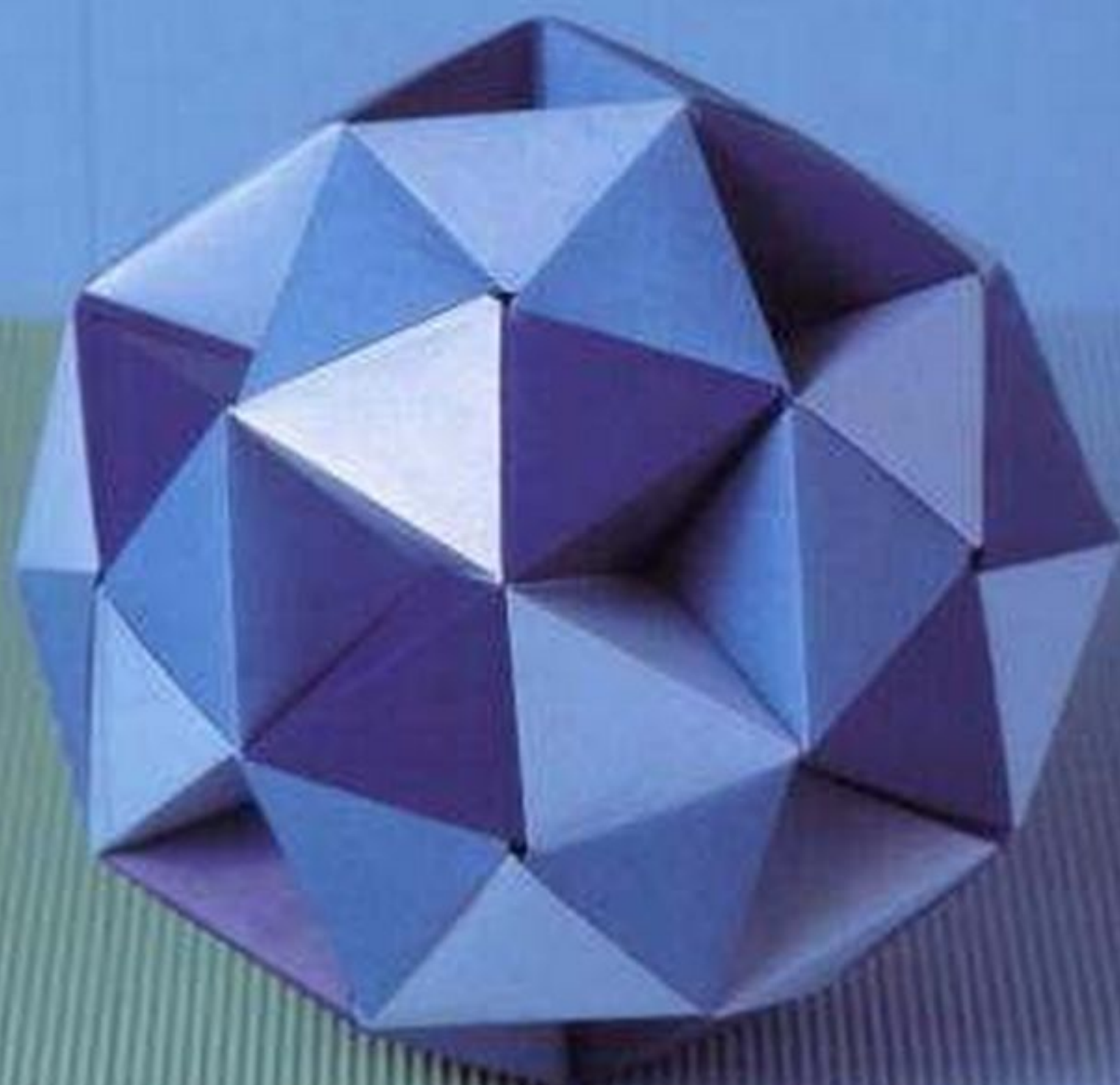
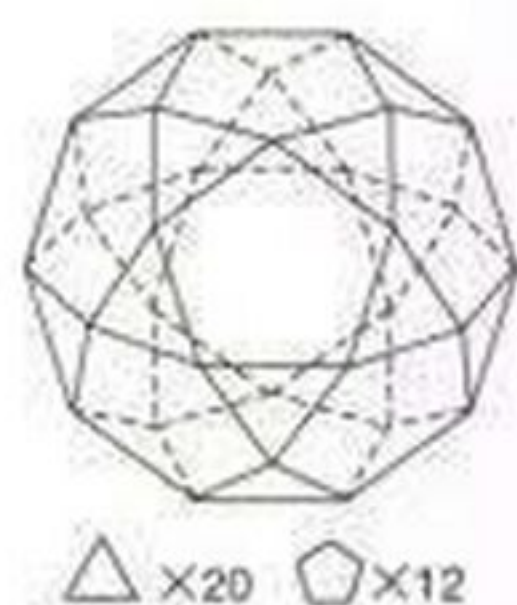
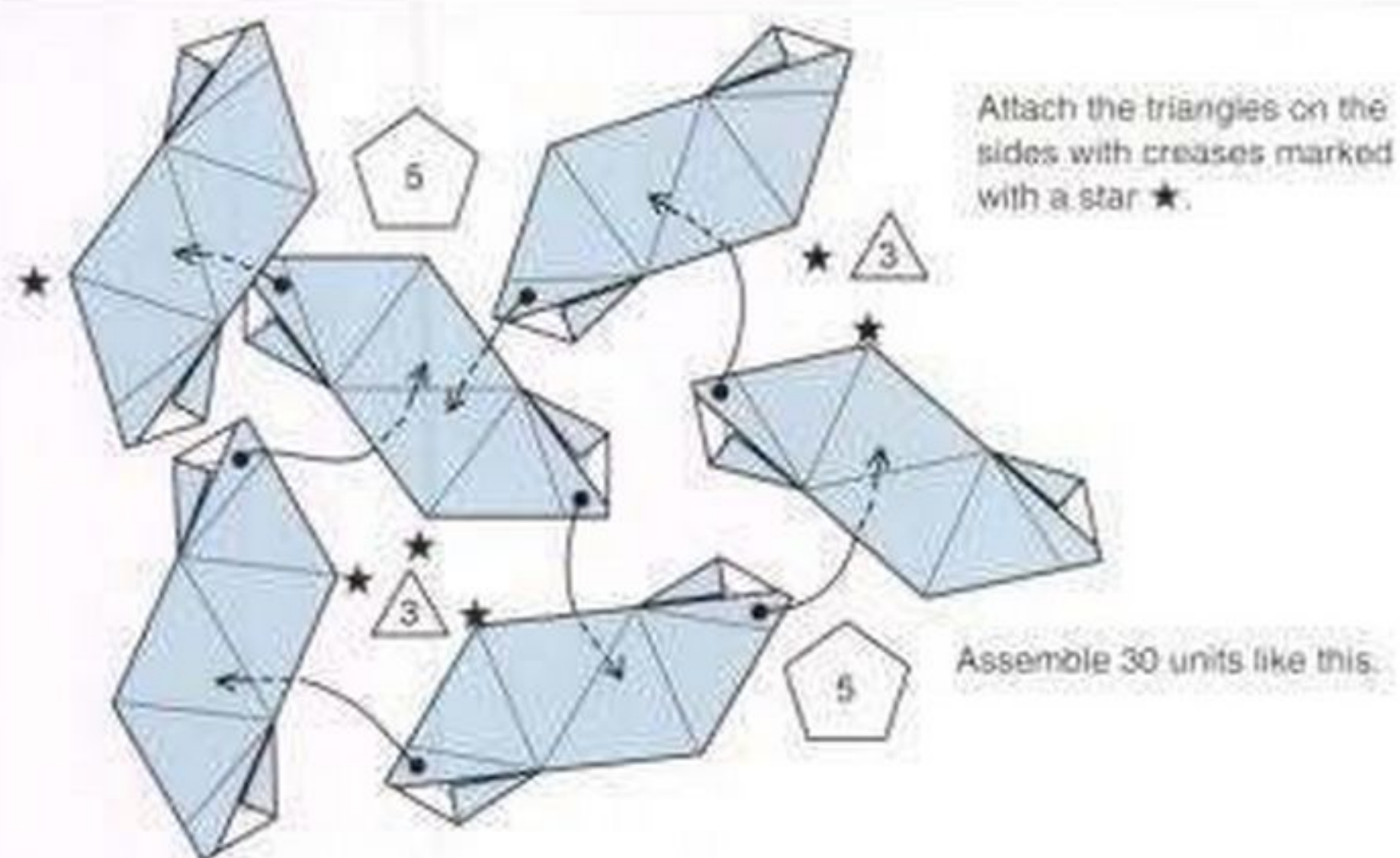
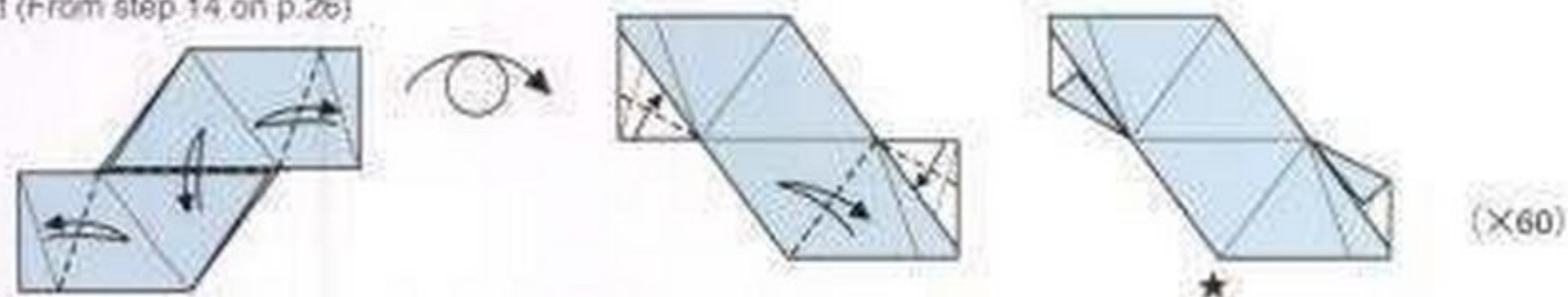



(A) has 1 crease and (B) has 2 creases. Assemble each of 60 units on the sides with the creases marked ★.

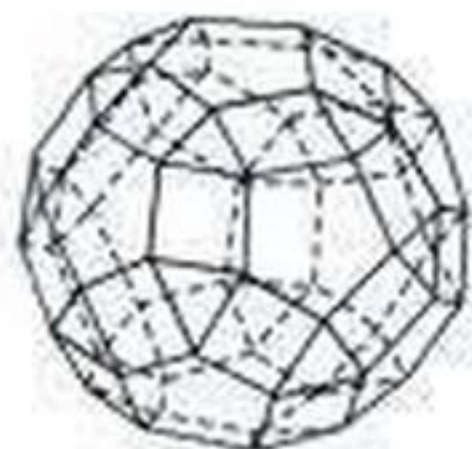
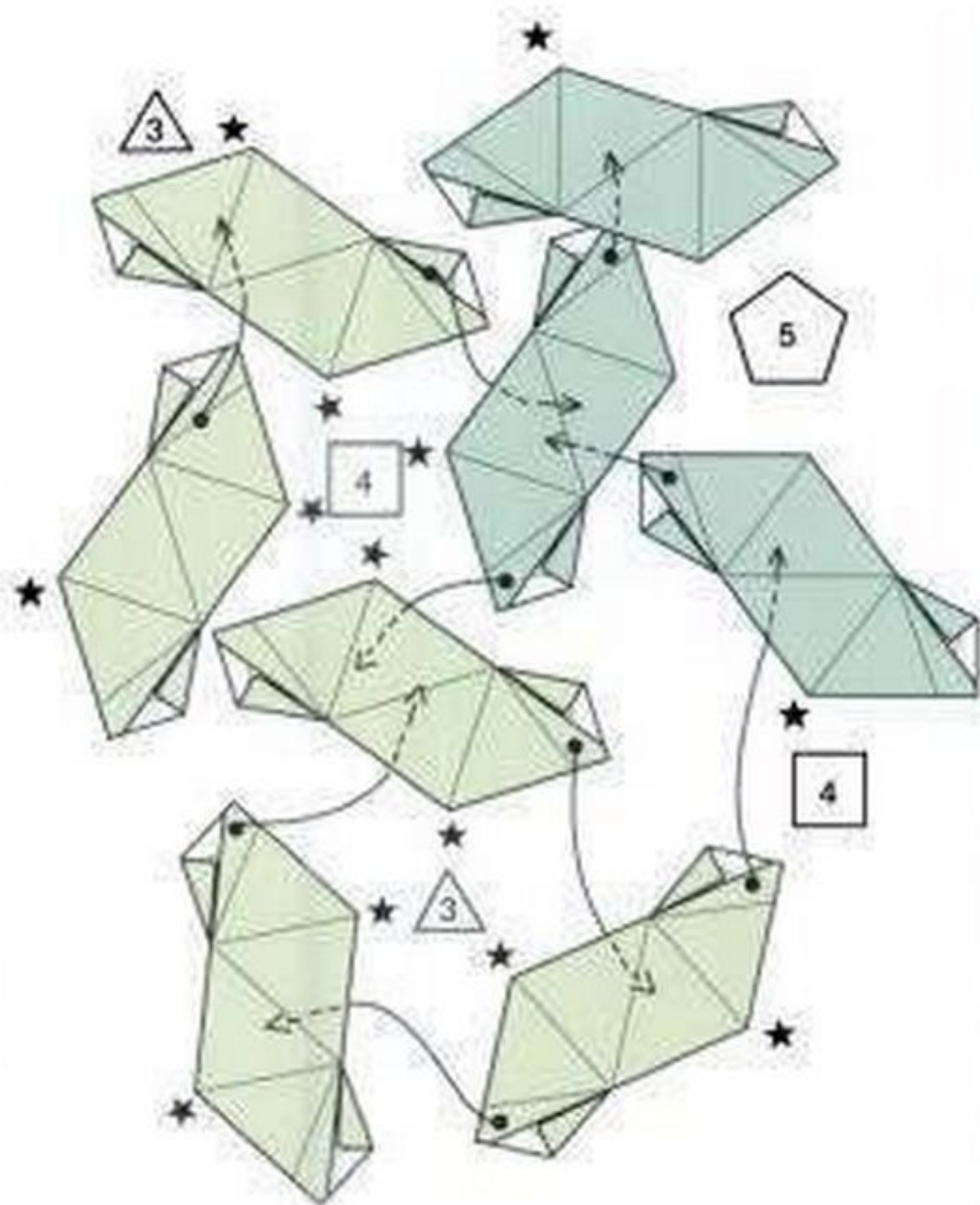
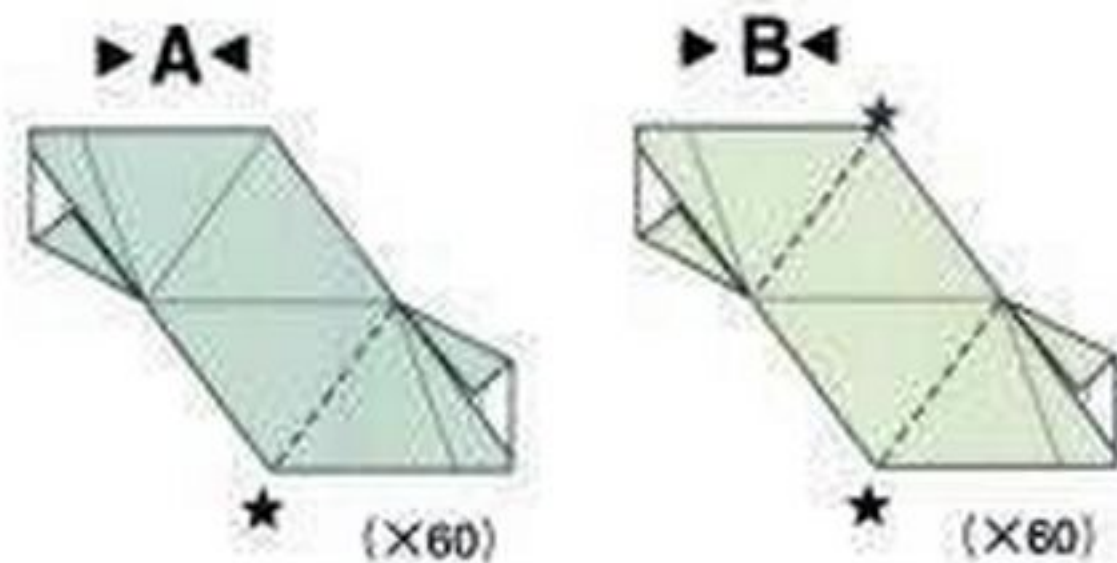

△×20   □×30   ○×12

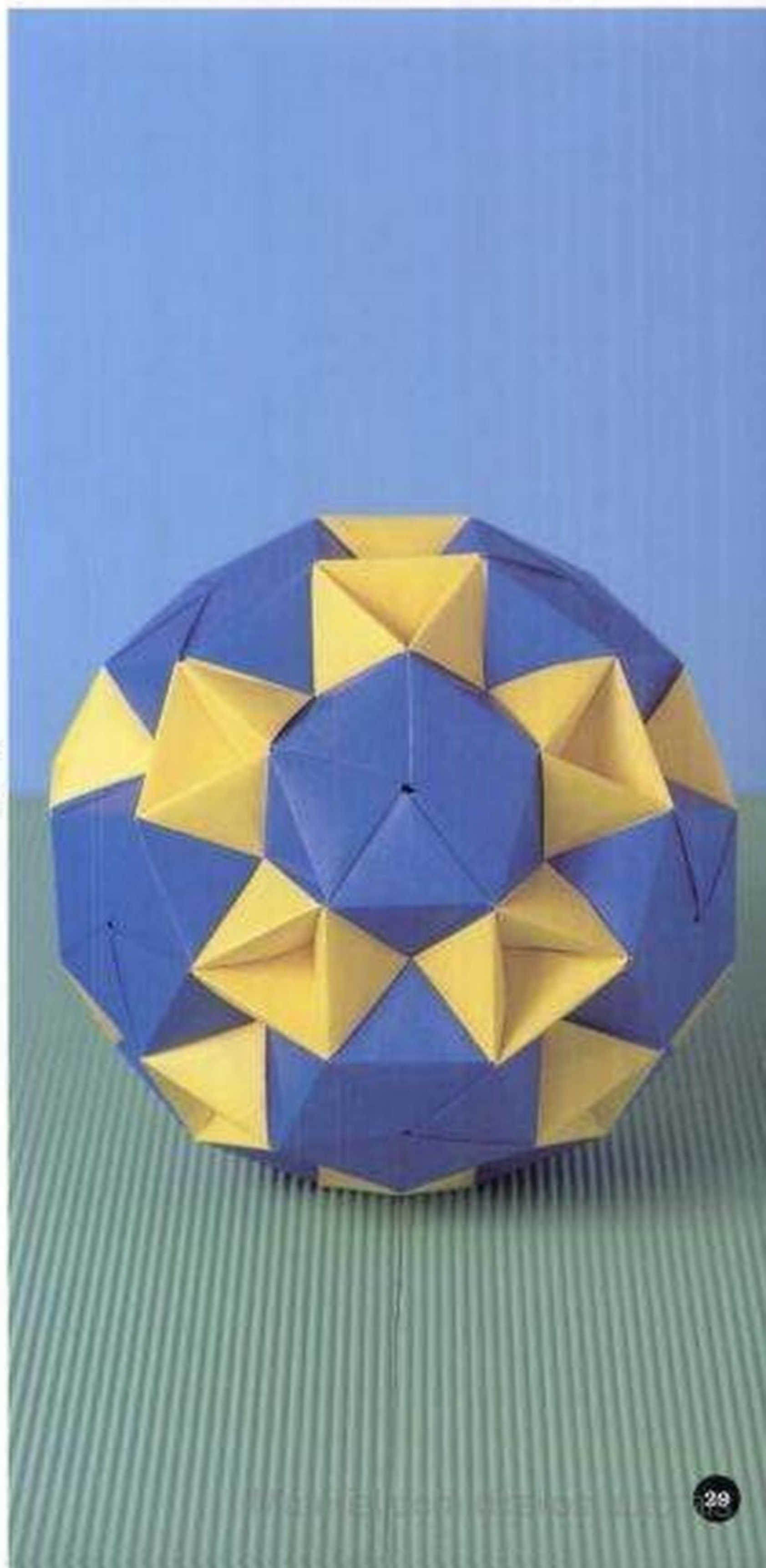



# KUSUDAMA DODECAHEDRON

level ★★

15cm × 15cm

Cut a square into three equal parts and make a rectangle with sides in a 1:3 ratio.

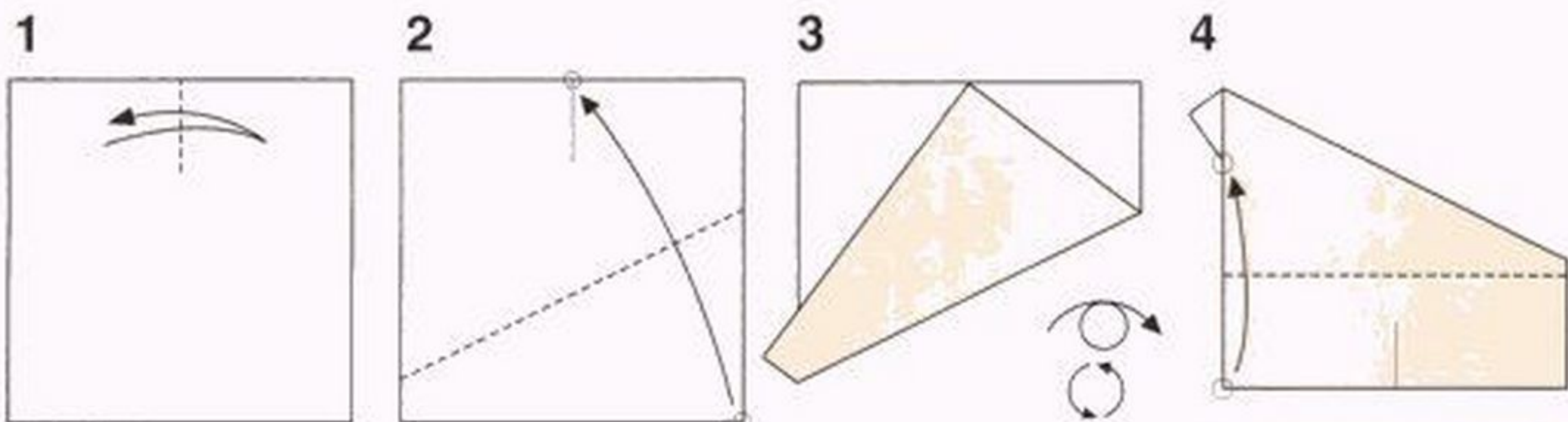

Make a short crease on the upper side.

Fold so as to join the circles ○.

Fold so as to join the circles ○.

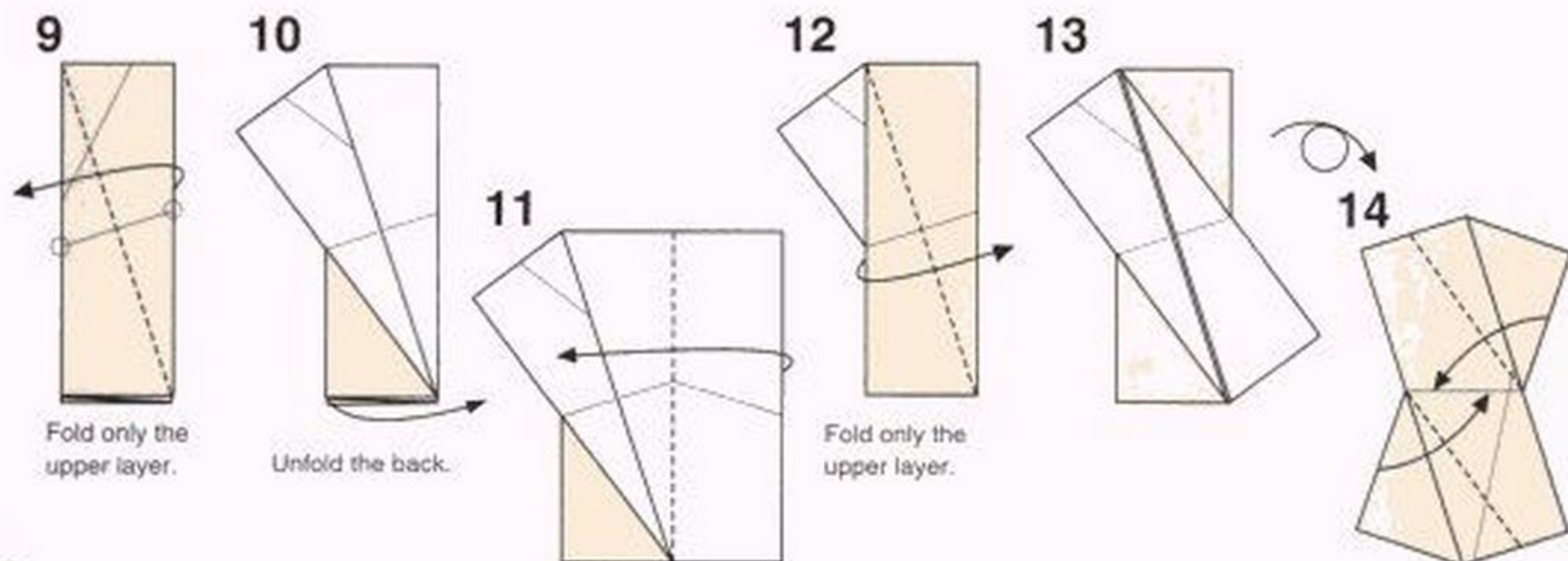
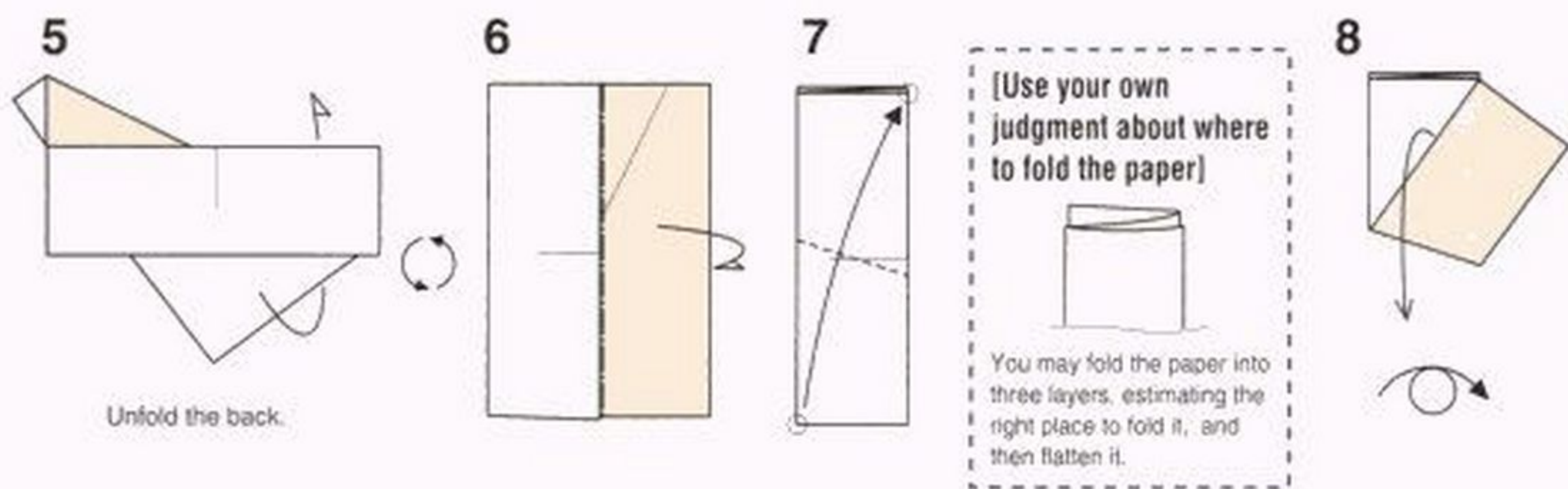

Fold only the upper layer.

Unfold the back.

Fold only the upper layer.



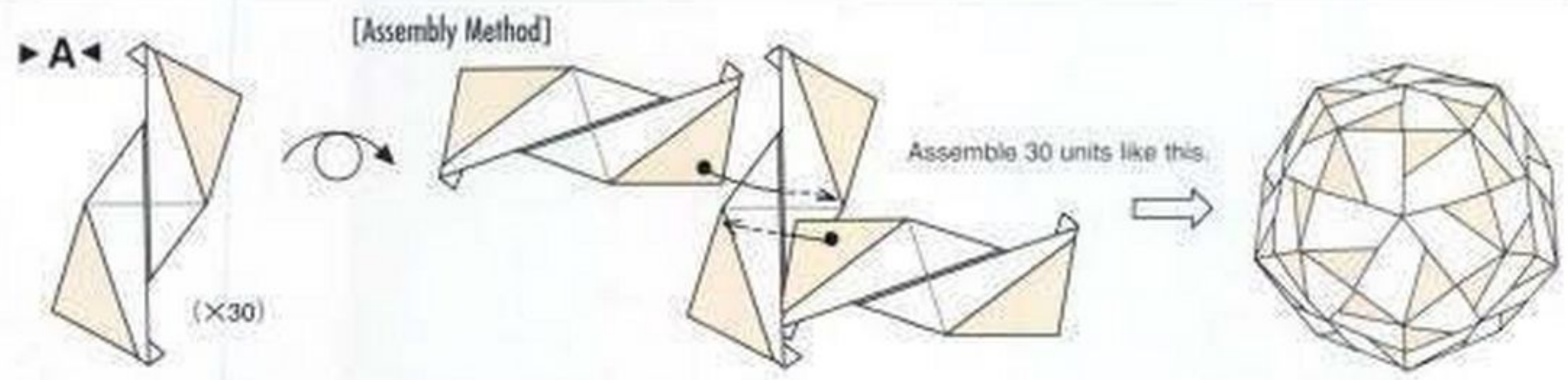
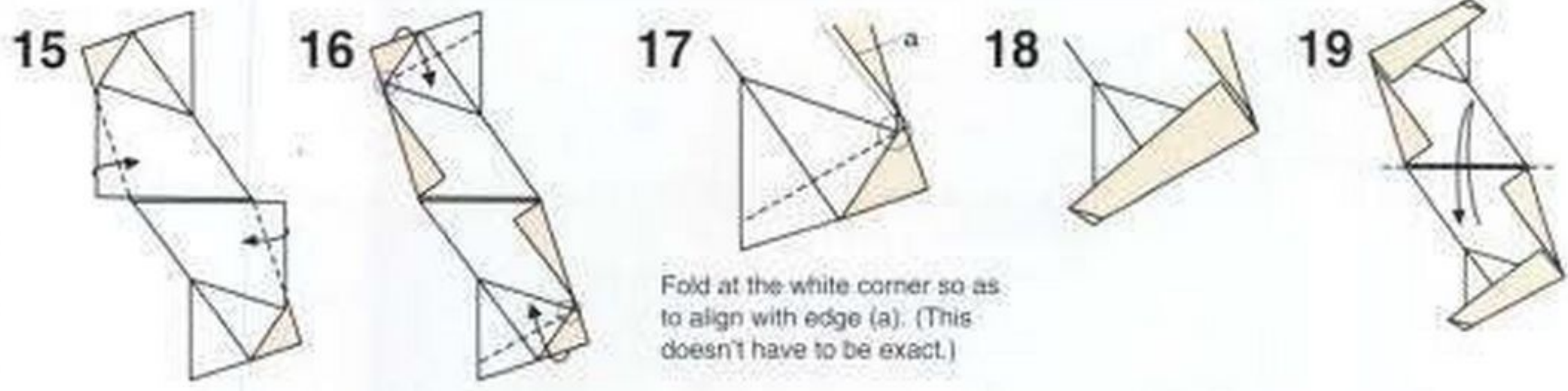

**CHANGE PATTERNS**

Starting with step 15, fold in the same way as in step 16.

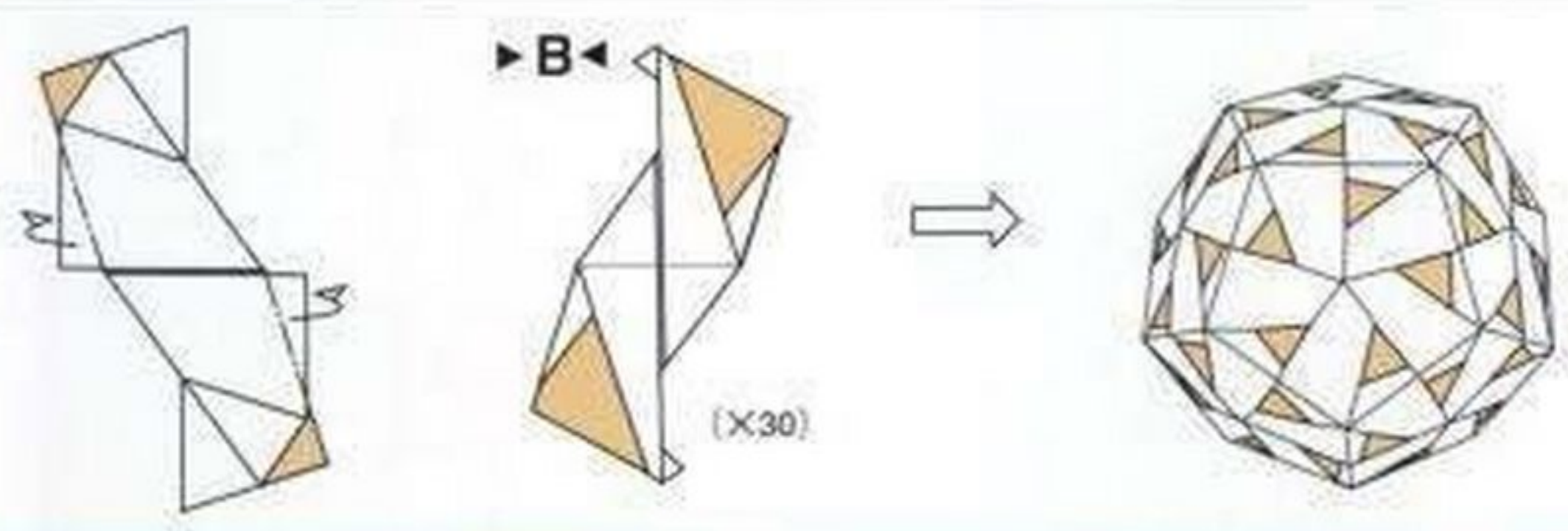



# 4

## REGULAR HEXAGONAL FLAT UNITS

There are two kinds of hexagonal flat units: one has 3 pockets on its 6 sides and the other has 6 pockets. Join the units with other elements, and create larger, more complex figures.

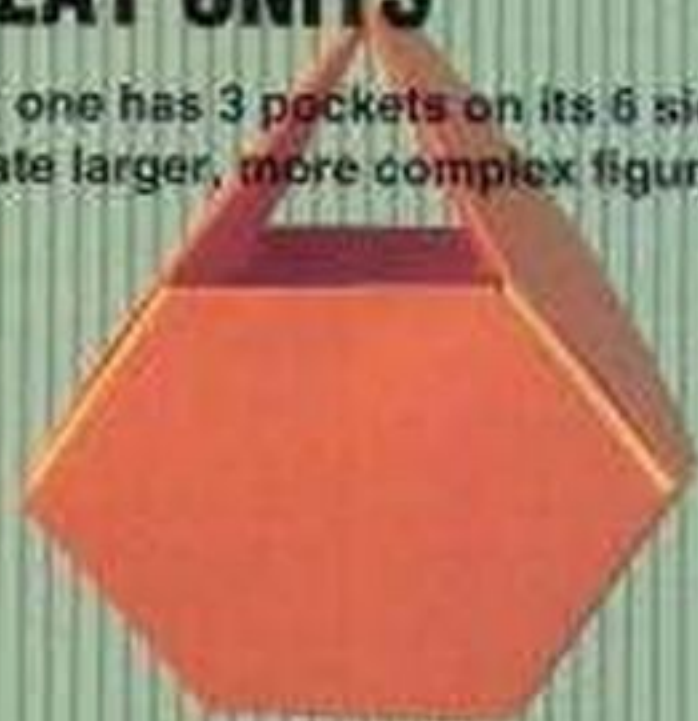

**TRUNCATED TETRAHEDRON** /p.36

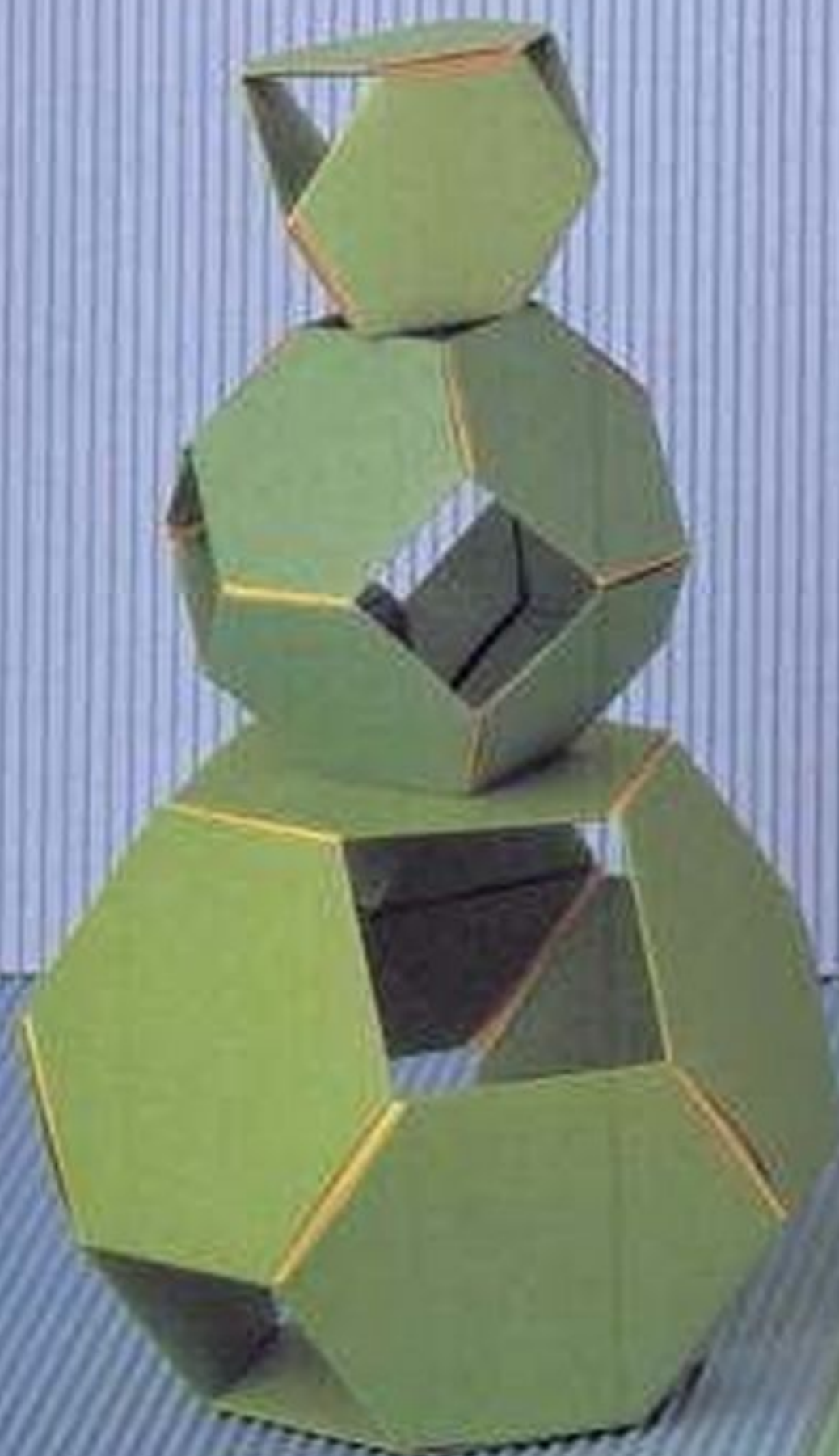

**USING REGULAR HEXAGONAL  
FLAT UNITS WITH 3 POCKETS (1)** /p.38

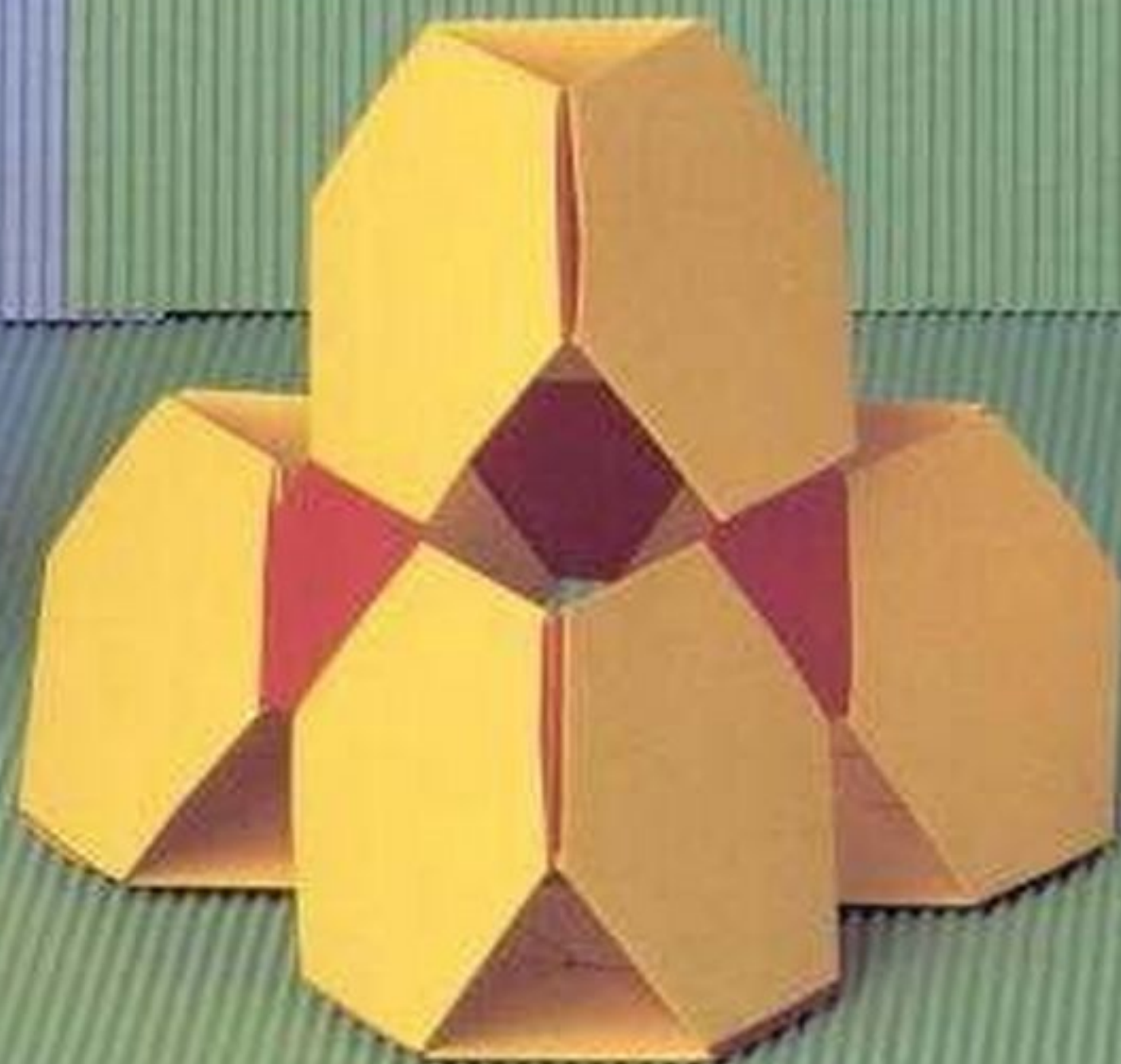

**TRUNCATED OCTAHEDRON** /p.36



# 4

## REGULAR HEXAGONAL FLAT UNITS

There are two kinds of hexagonal flat units: one has 3 pockets on its 6 sides and the other has 6 pockets. Join the units with other elements, and create larger, more complex figures.

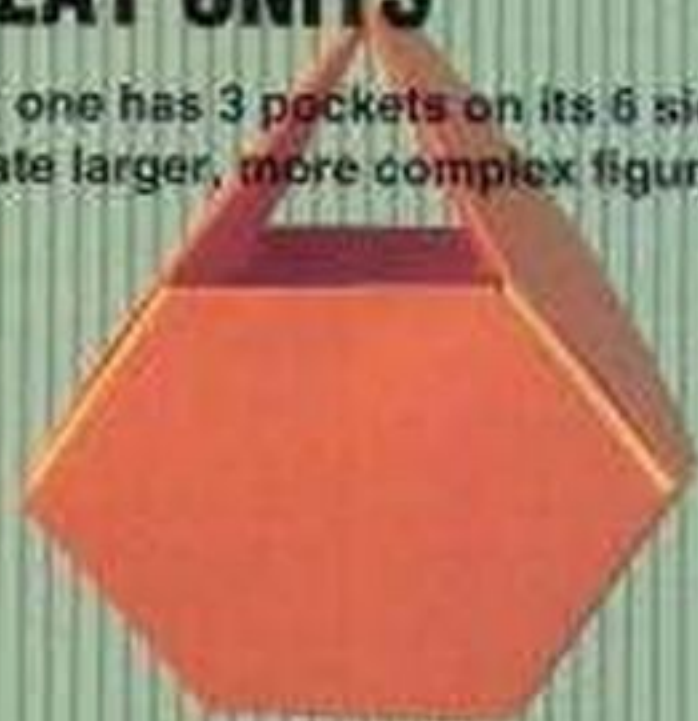

**TRUNCATED TETRAHEDRON** /p.36

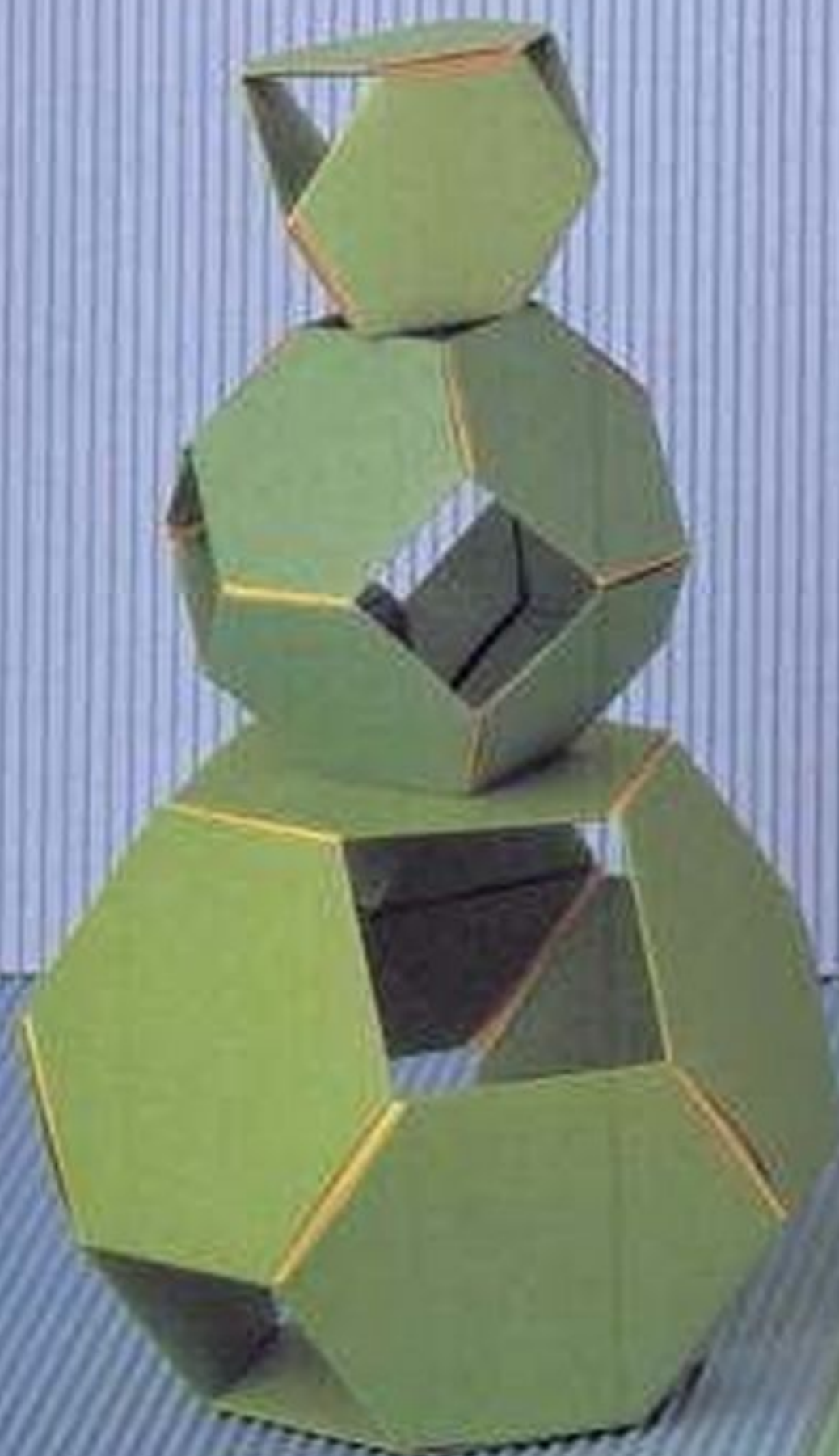

**USING REGULAR HEXAGONAL  
FLAT UNITS WITH 3 POCKETS (1)** /p.38

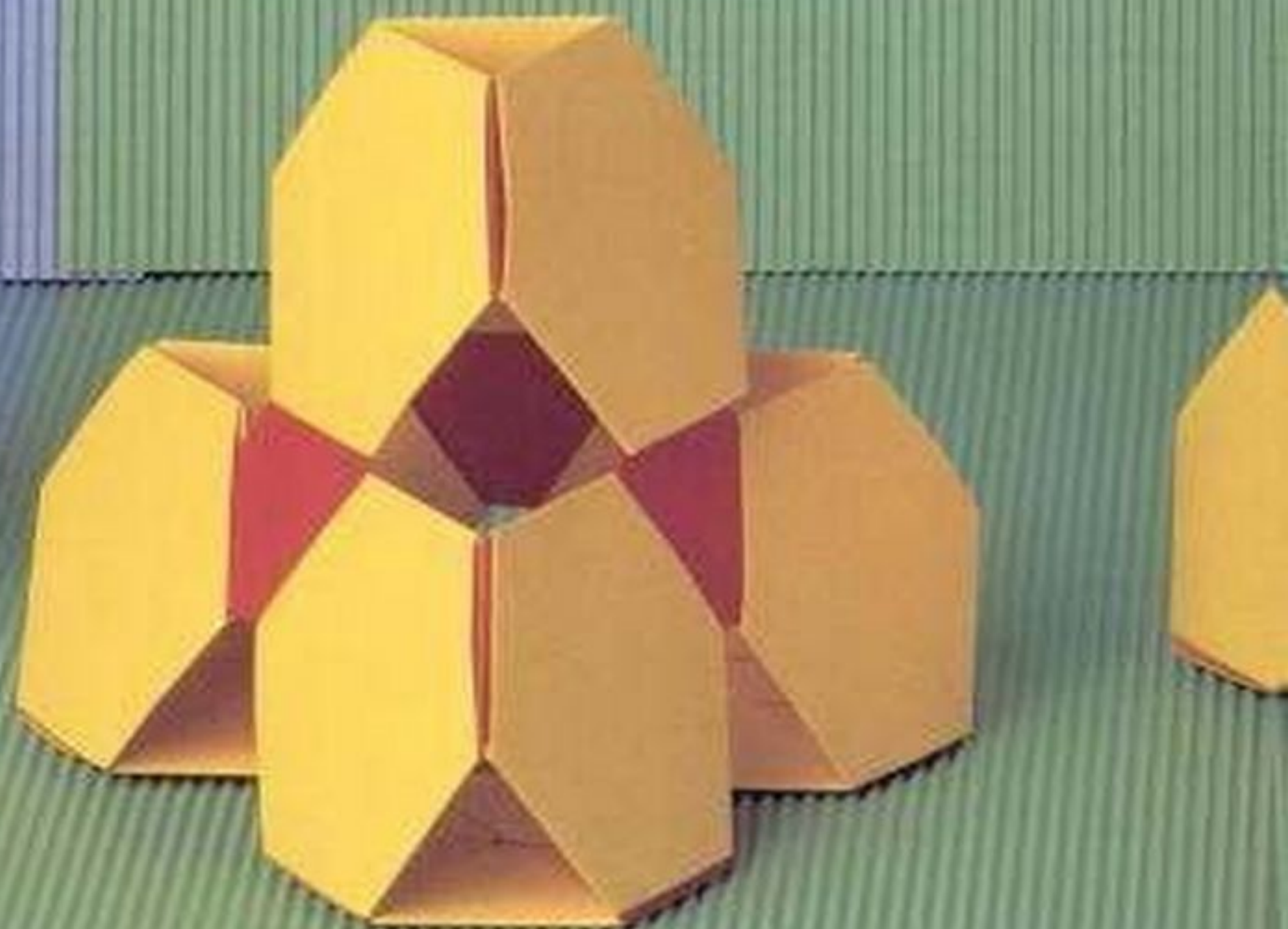

**TRUNCATED OCTAHEDRON** /p.36



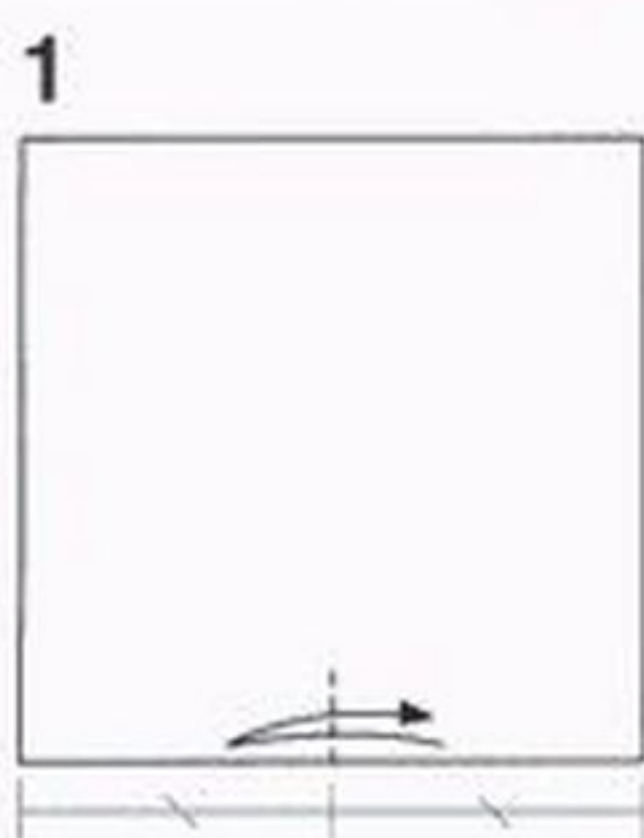

Make a short crease on the lower side.

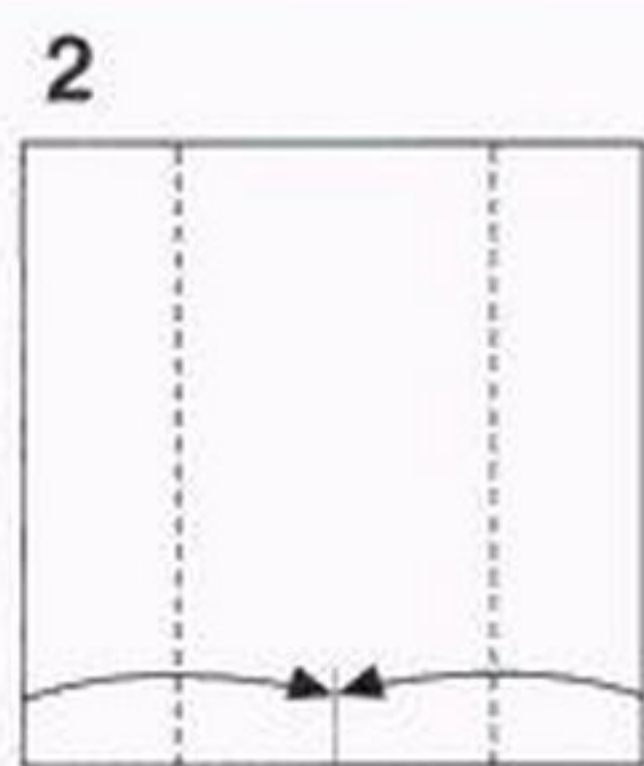

Fold so as to join the two circles ○, using the corner △ as the pivot.

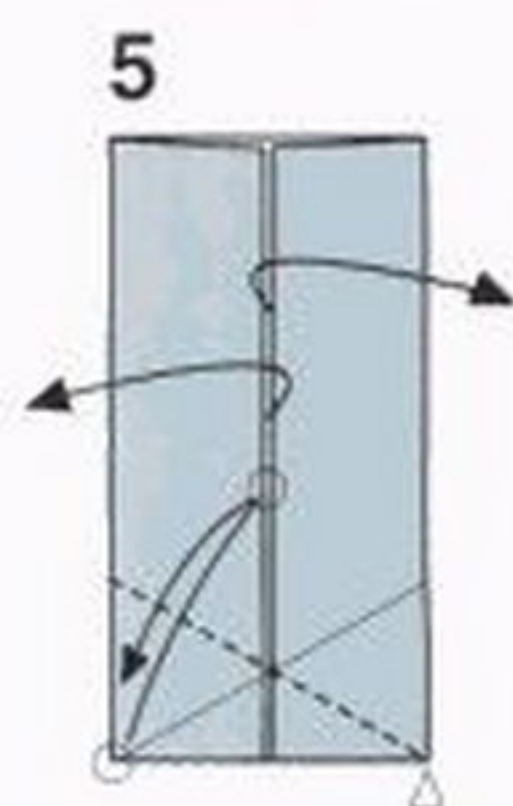

Make a crease and unfold.

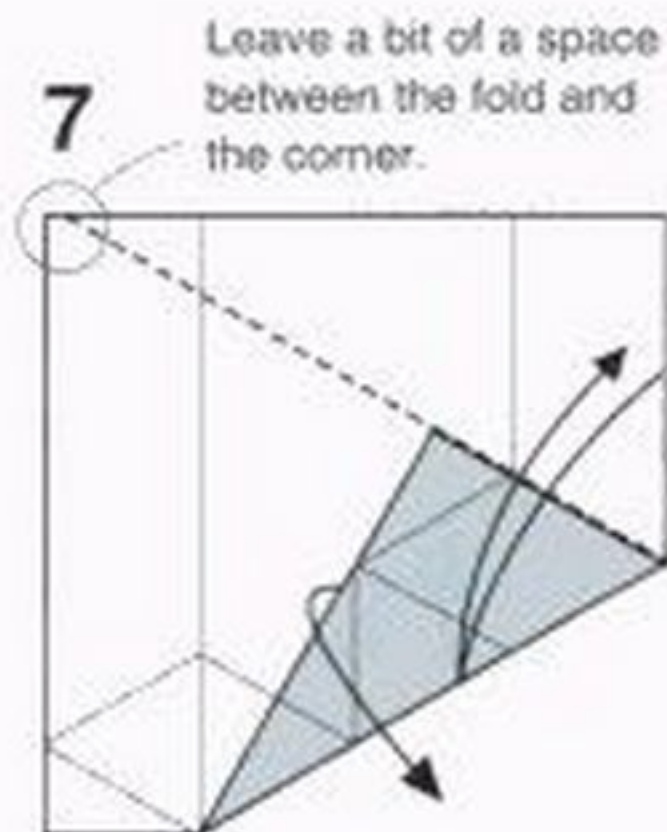
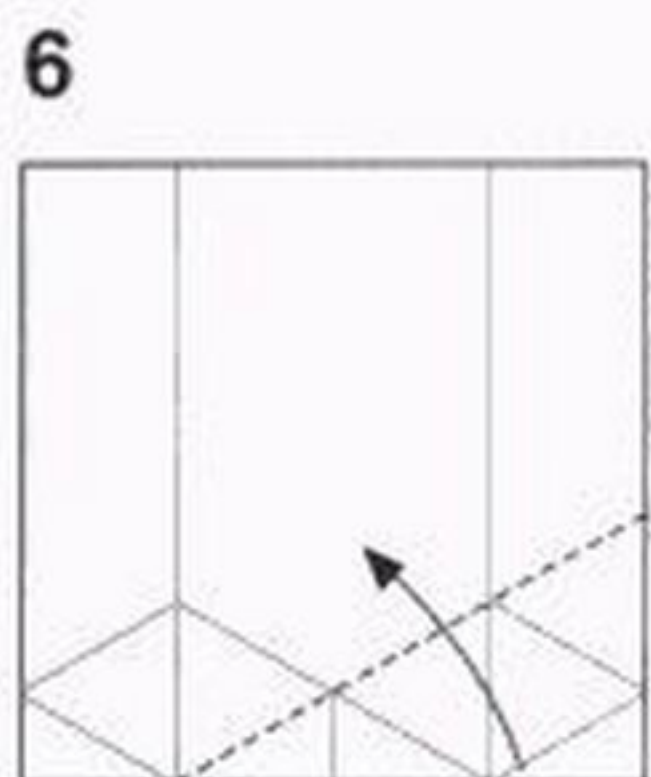

Make a crease and unfold.

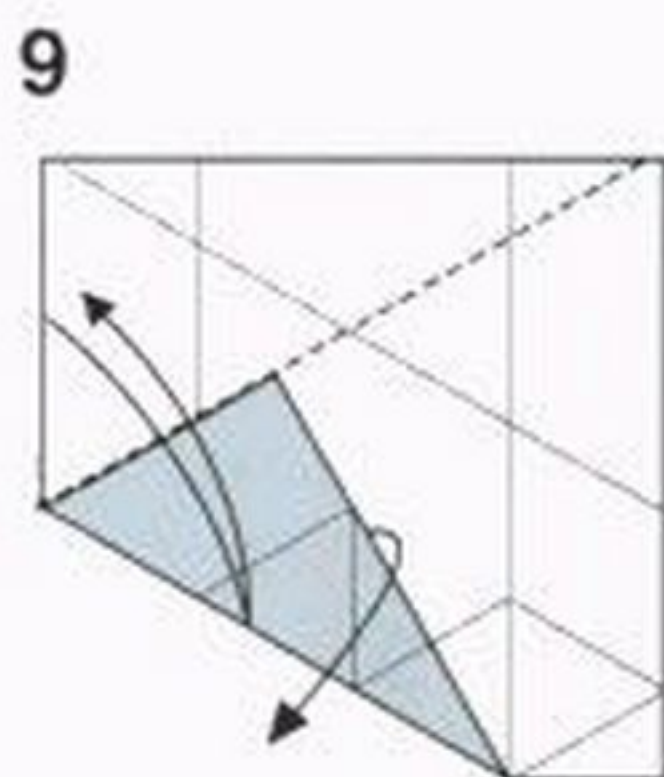
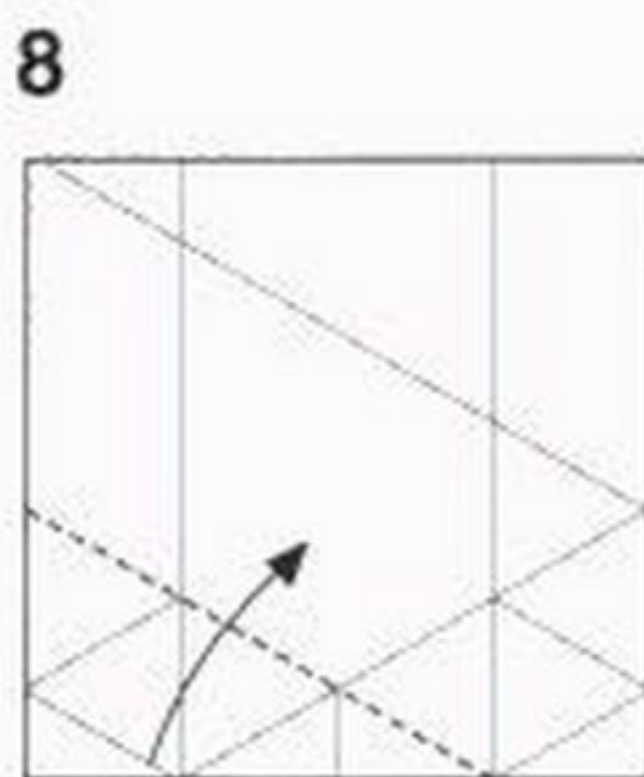

Make a crease and unfold.

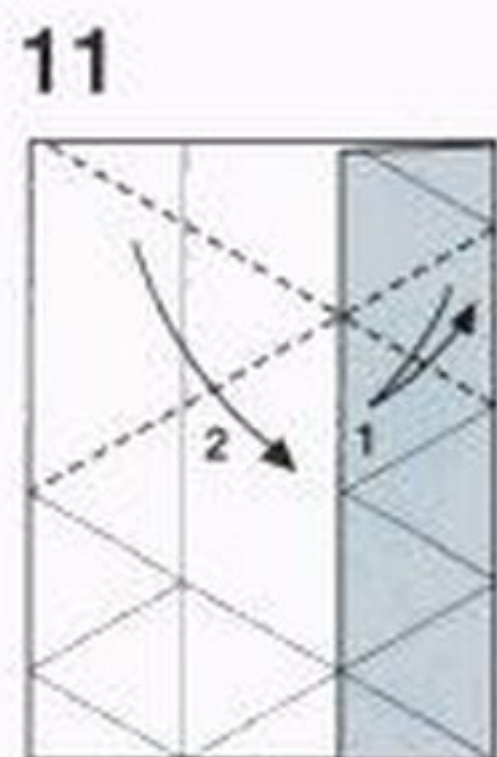
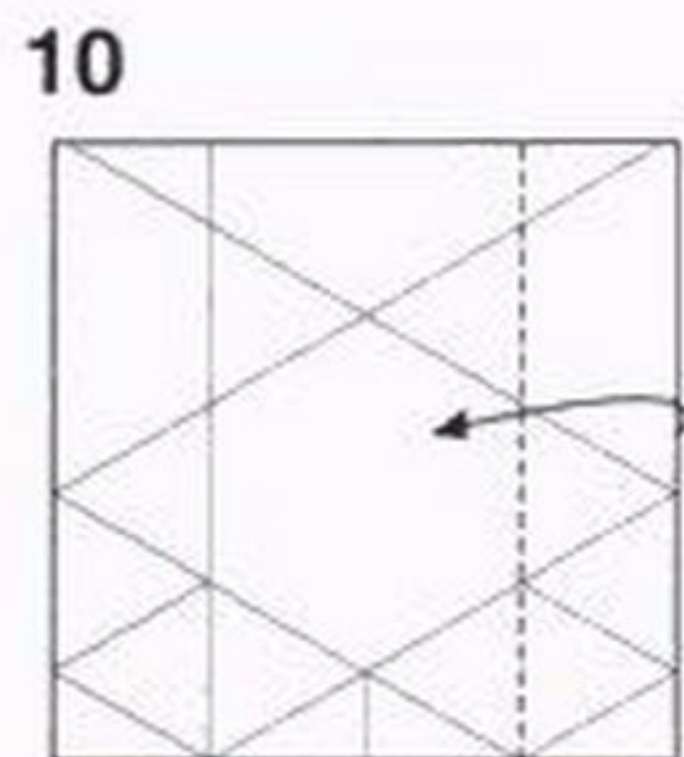

Fold in numerical order.

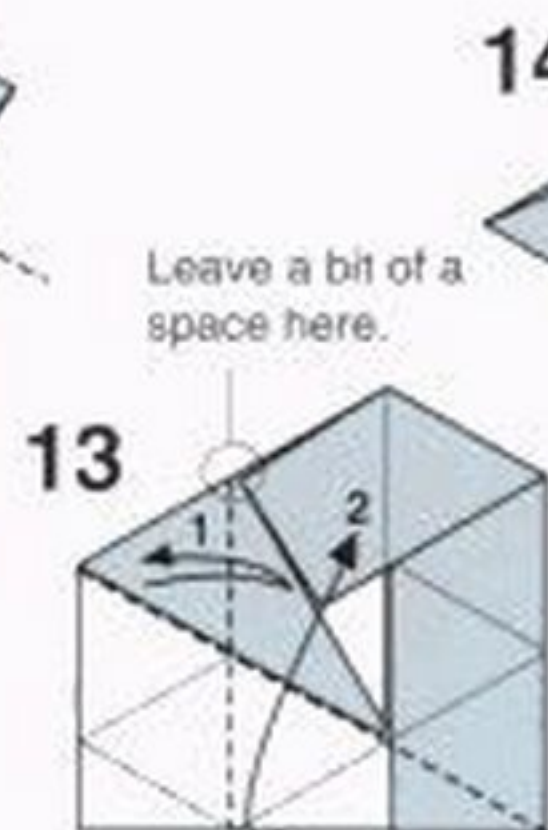
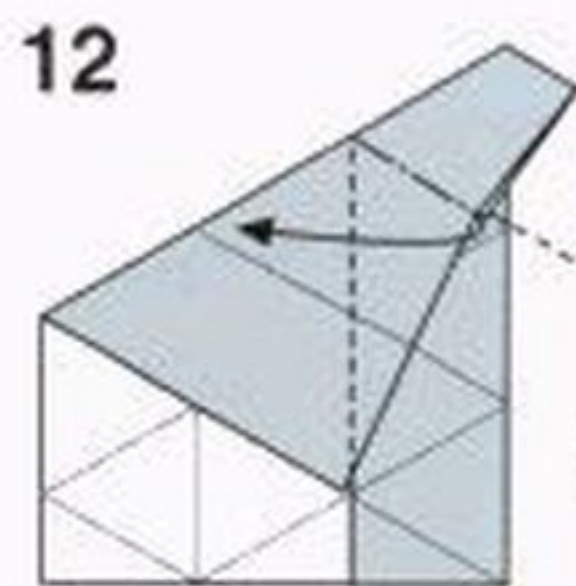

Fold in numerical order.

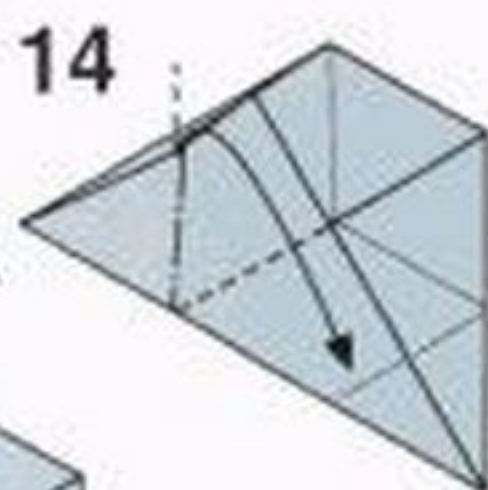



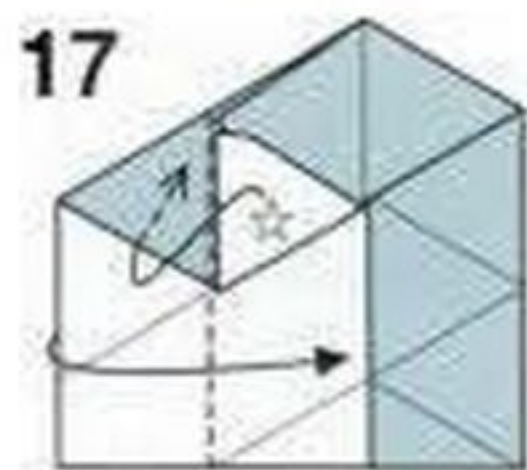
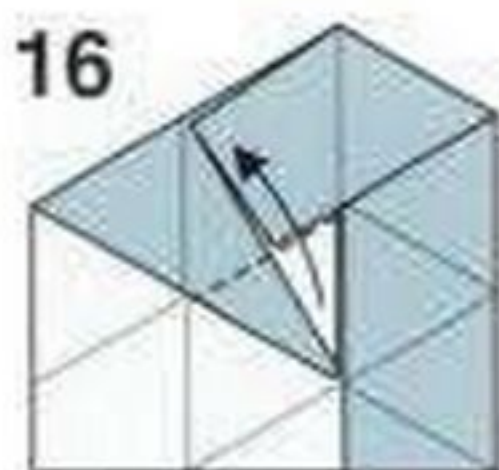
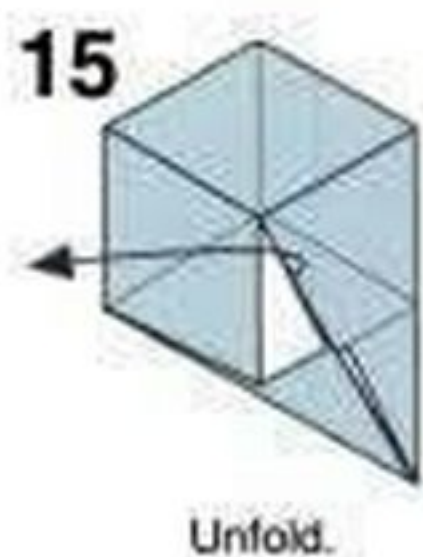

Insert flap marked with the star ☆ into the slit and fold the left side.

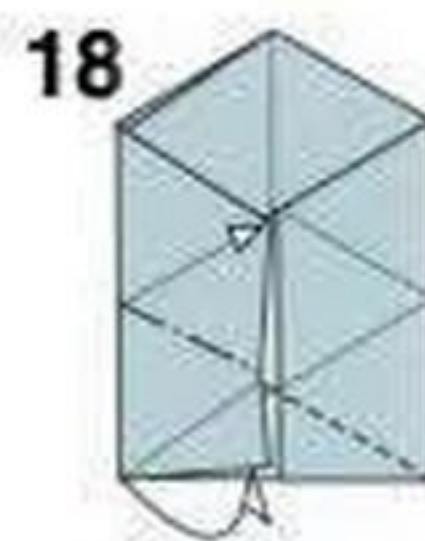

Inside reverse fold

Be sure that the part marked with the triangle is securely tucked in.

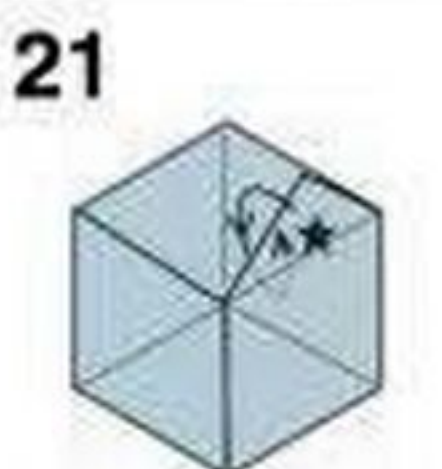
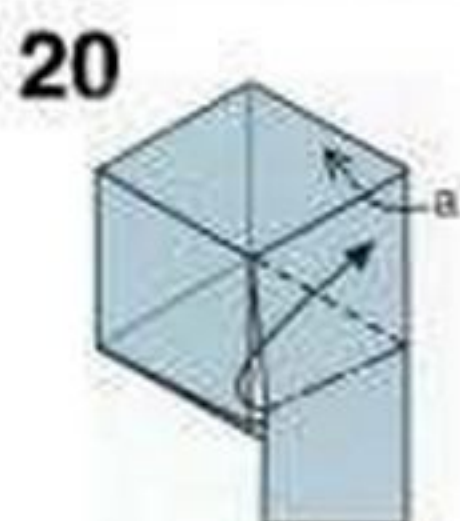
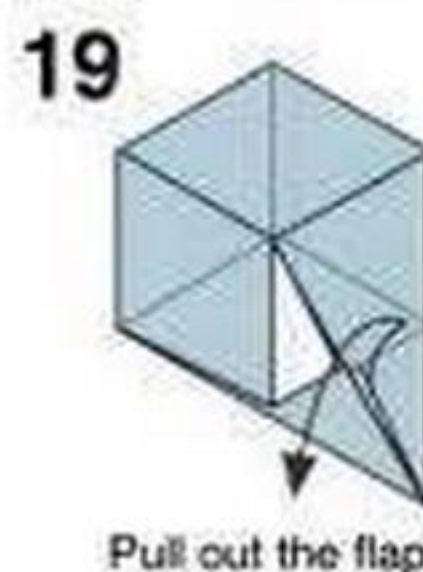

Insert the flap ★ into slit (a) of step 20.

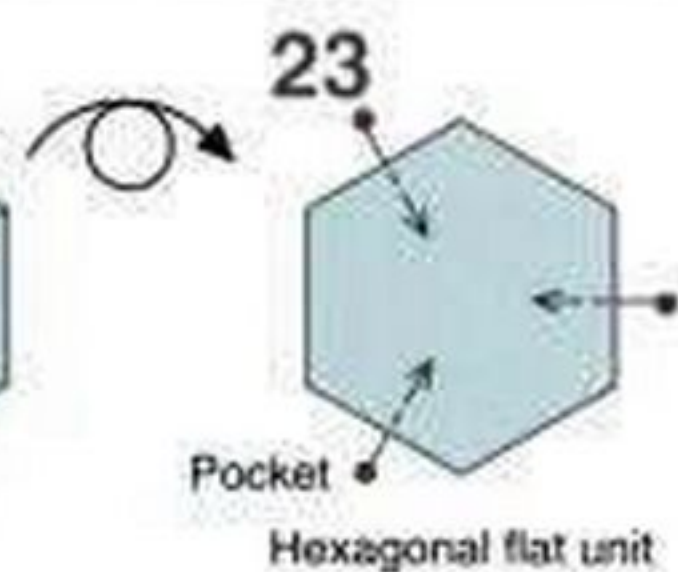

### Simple Form

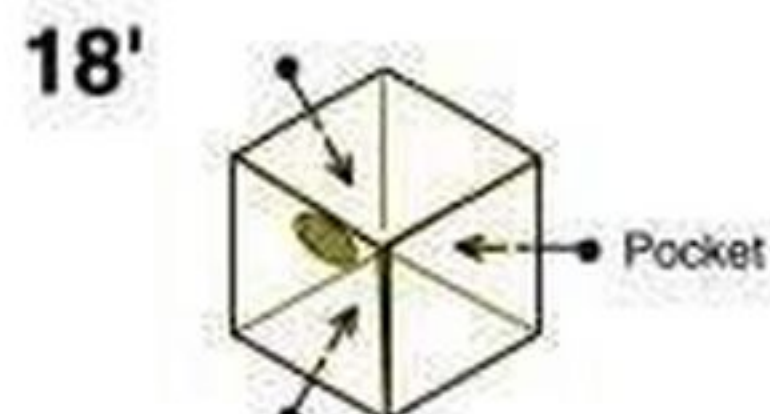
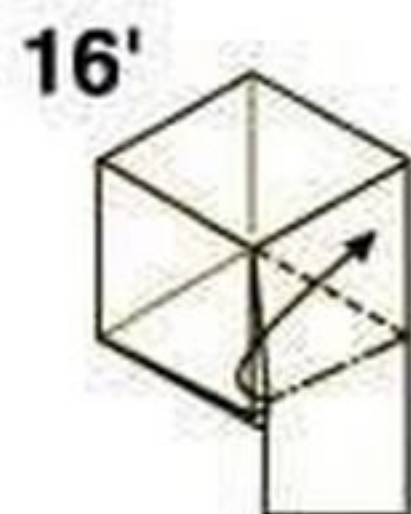
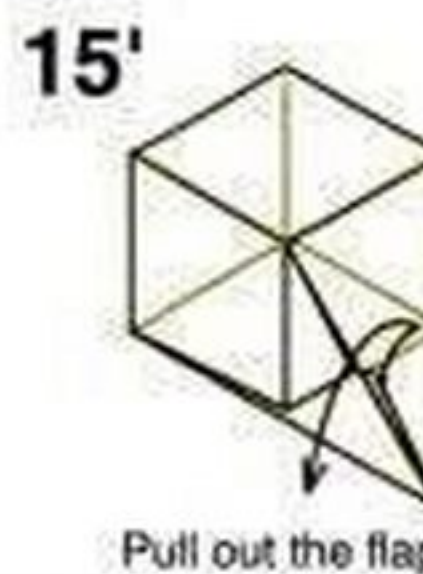

Glue the inside of the shaded part so that it stays in place.

### Joint C

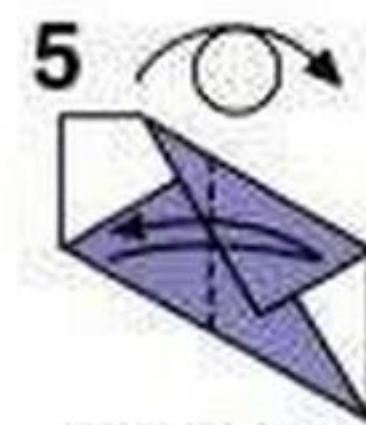
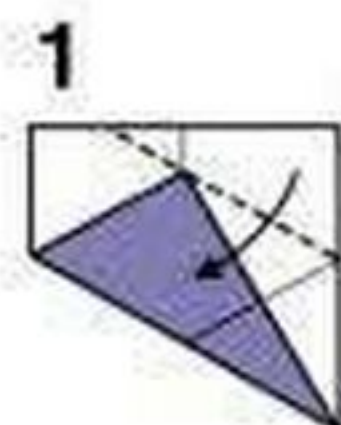
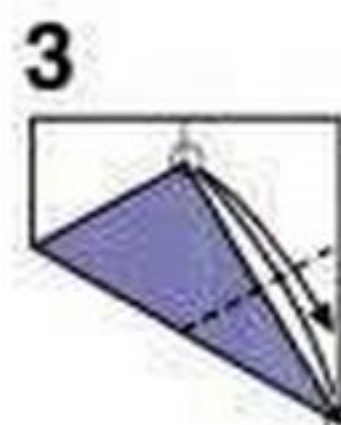
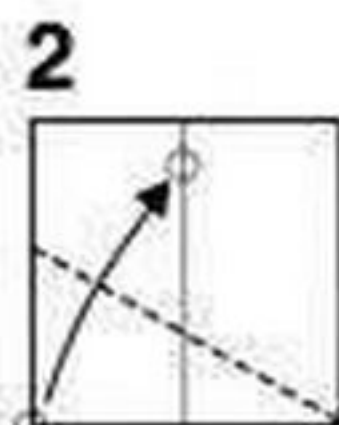
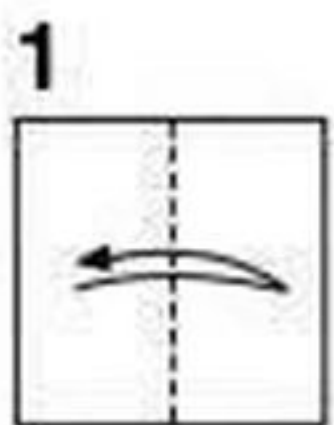
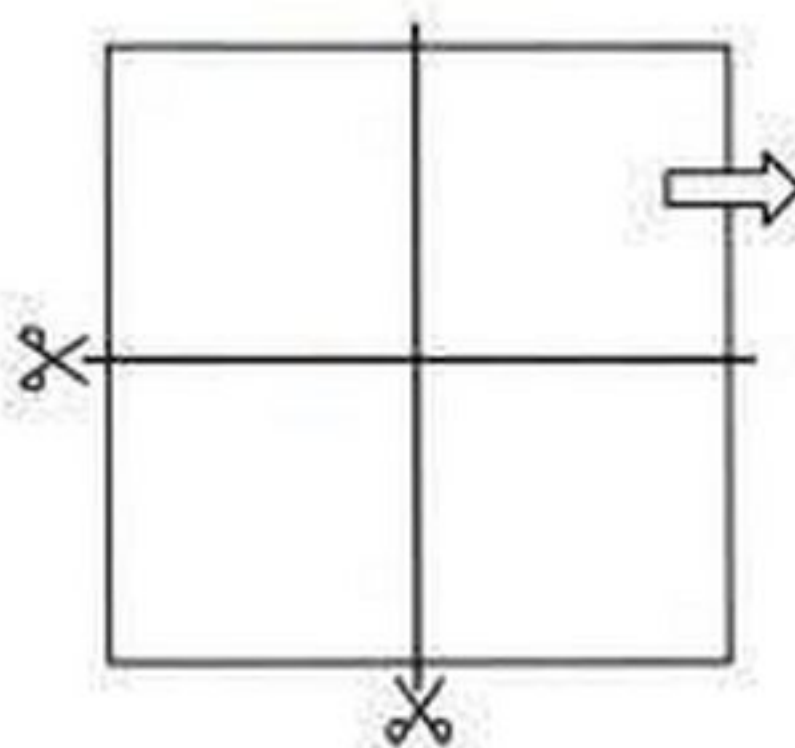

Fold in half on the crease.

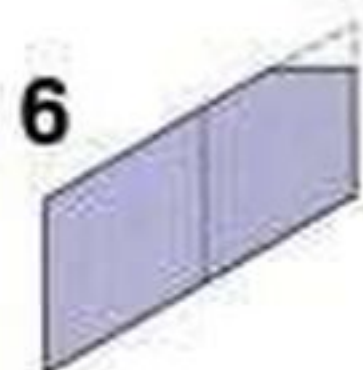

The corner is missing from the joint, but this is not a problem. Insert it in any direction you like.

### [Assembly Method]

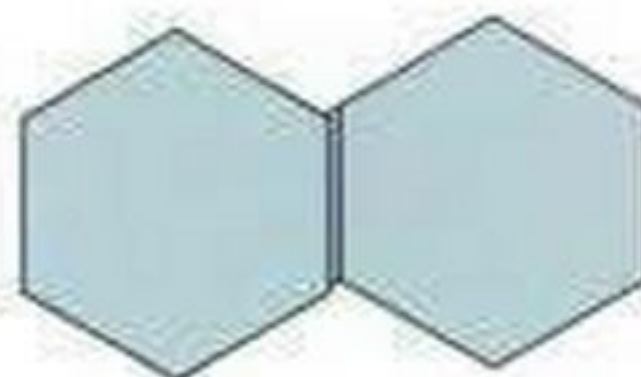
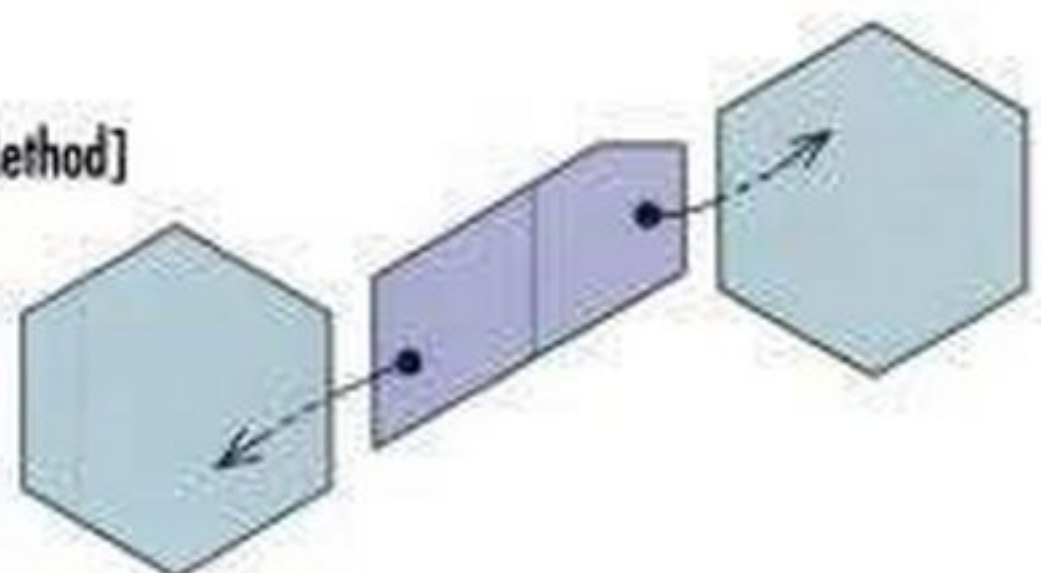



# TRUNCATED TETRAHEDRON AND OCTAHEDRON

level ★

12cm × 12cm

Hexagonal flat unit (p. 34)

Joint C (p. 35)

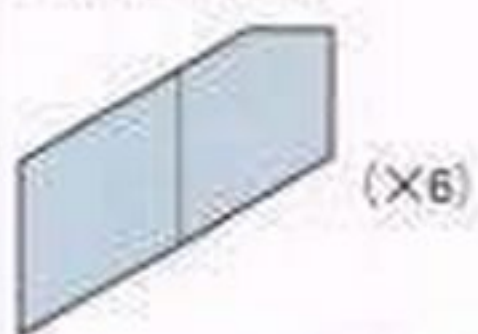
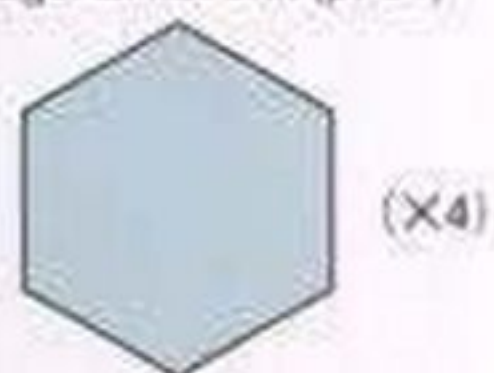

Hexagonal flat unit (p. 34)

Joint C (p. 35)

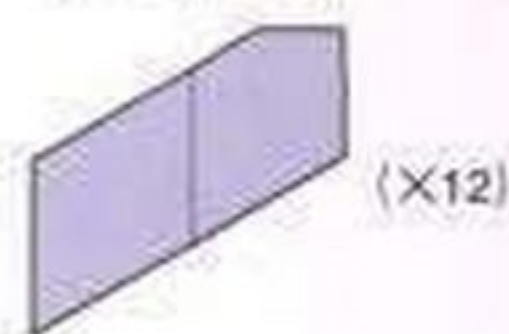

The finished work appears to have "windows."

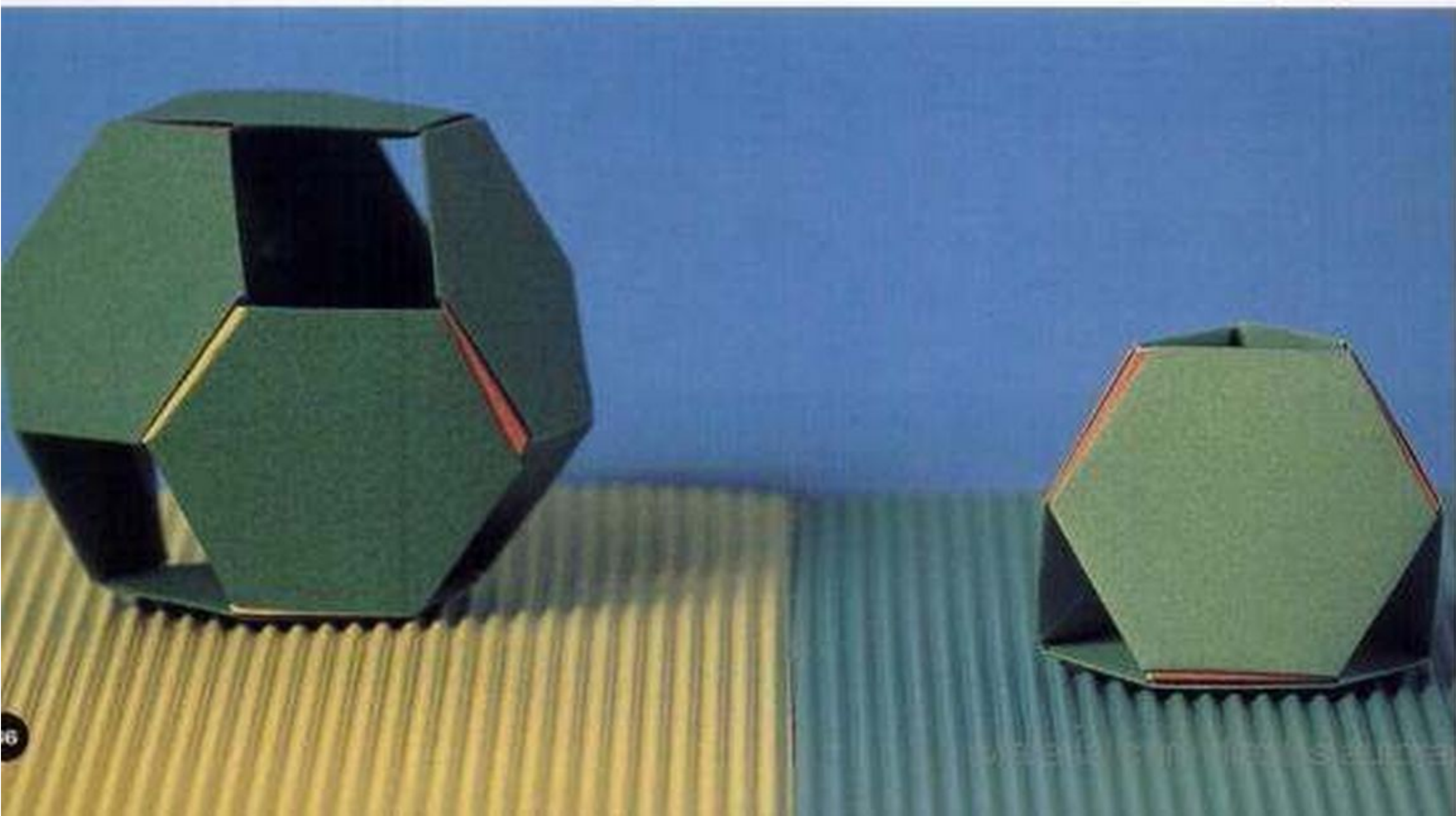
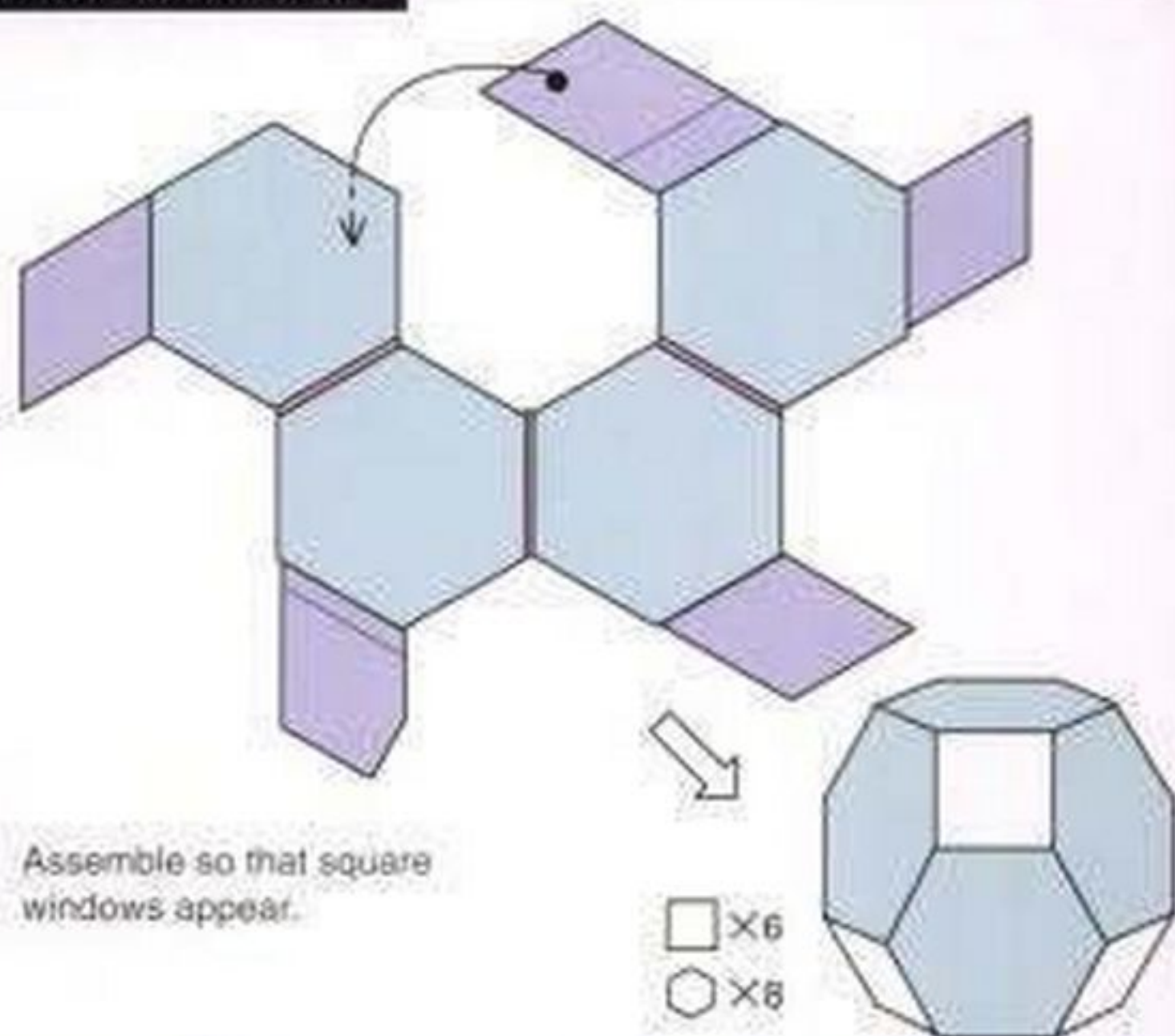
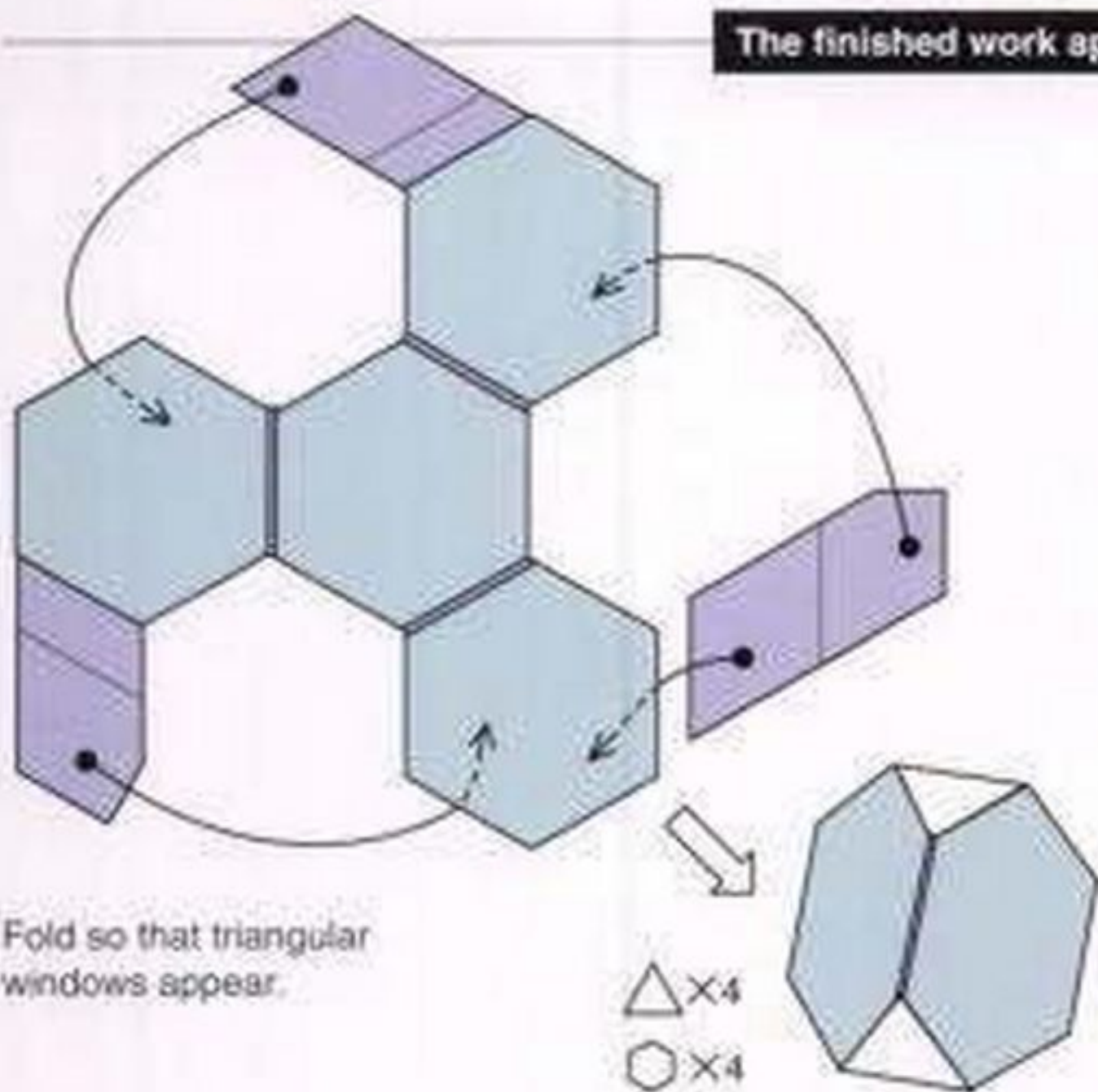



Hexagonal flat unit (p. 34)



Joint C (p. 35)

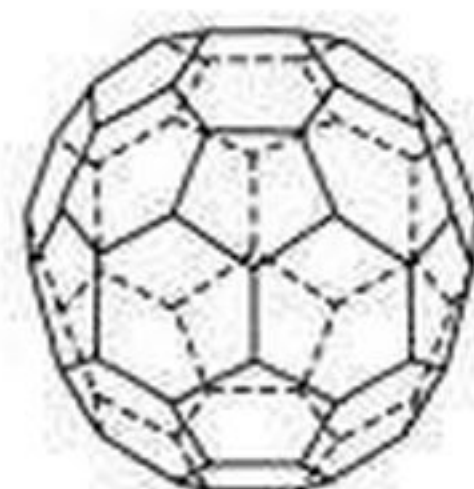
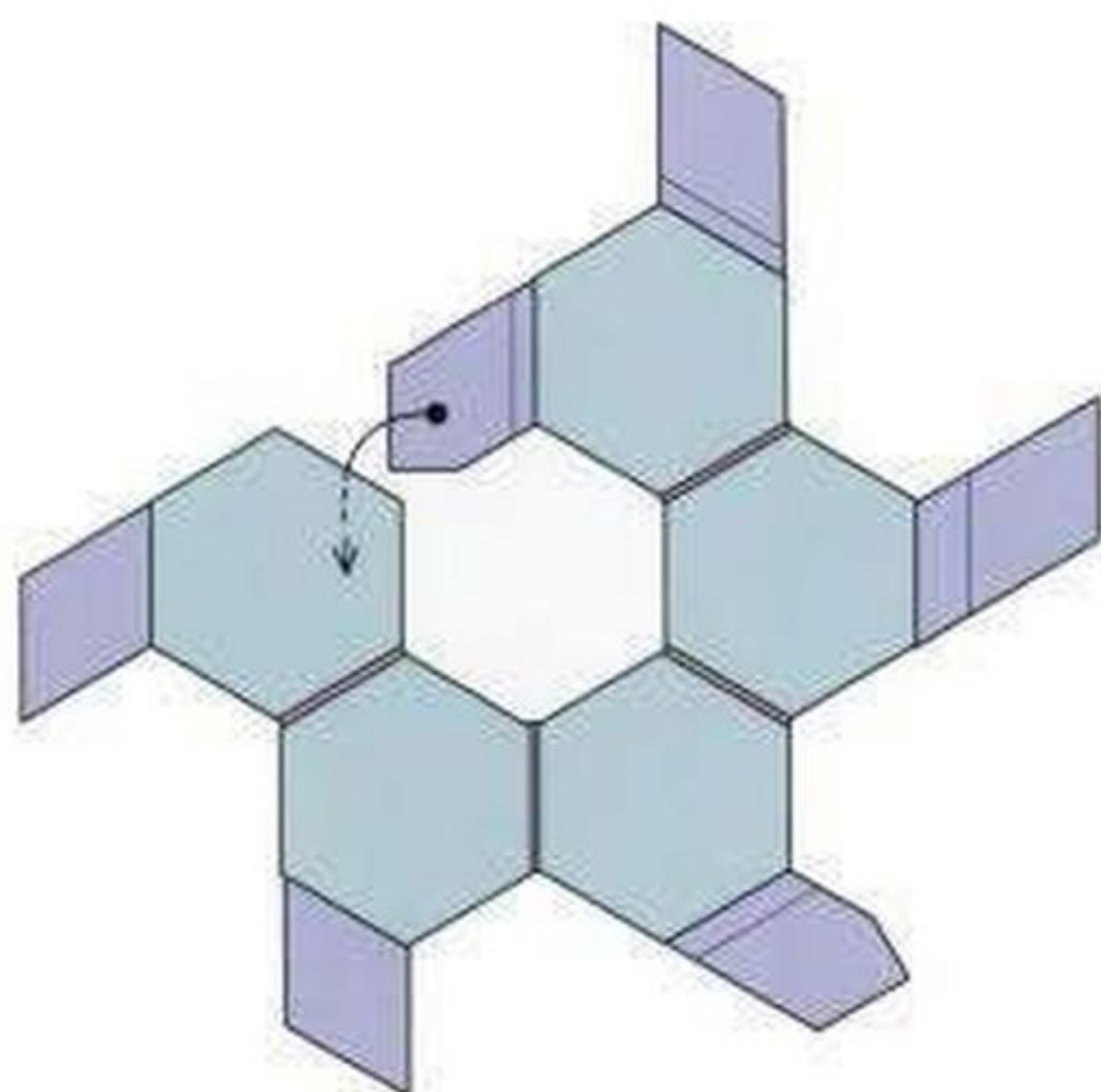
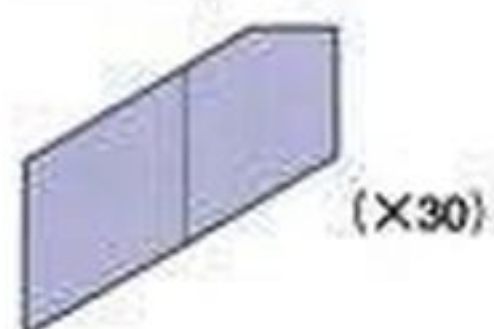

⬠ × 12   ⬡ × 20



Assemble so that pentagonal windows appear.





Triangle Element A

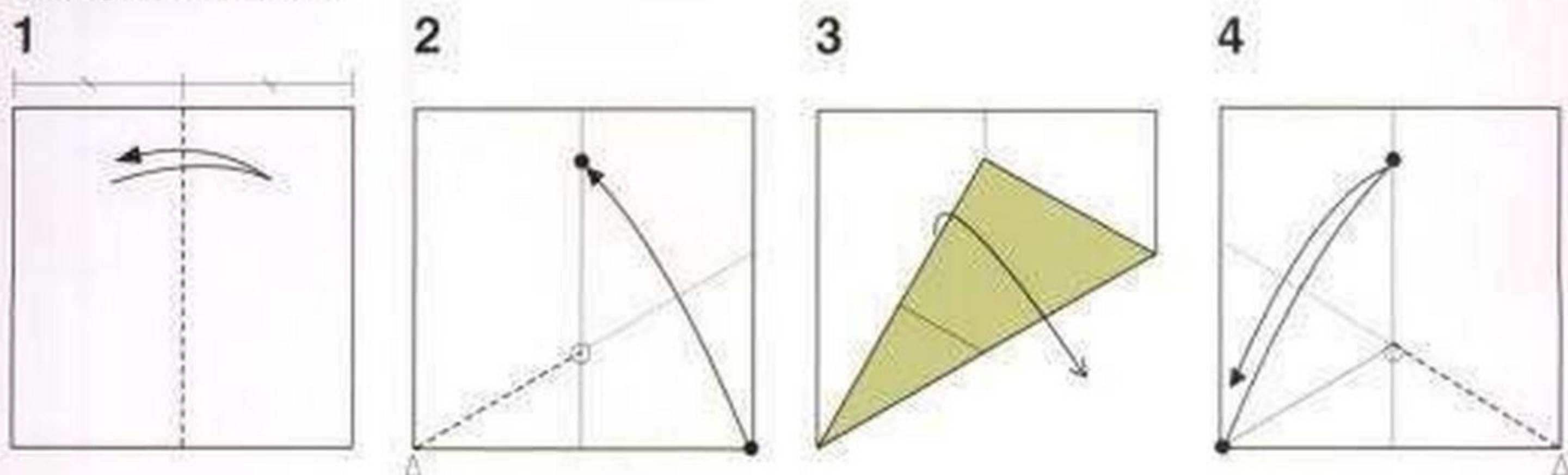

Fold the corner marked with the black dot up to the other black dot, using the corner marked with a triangle as the pivot.

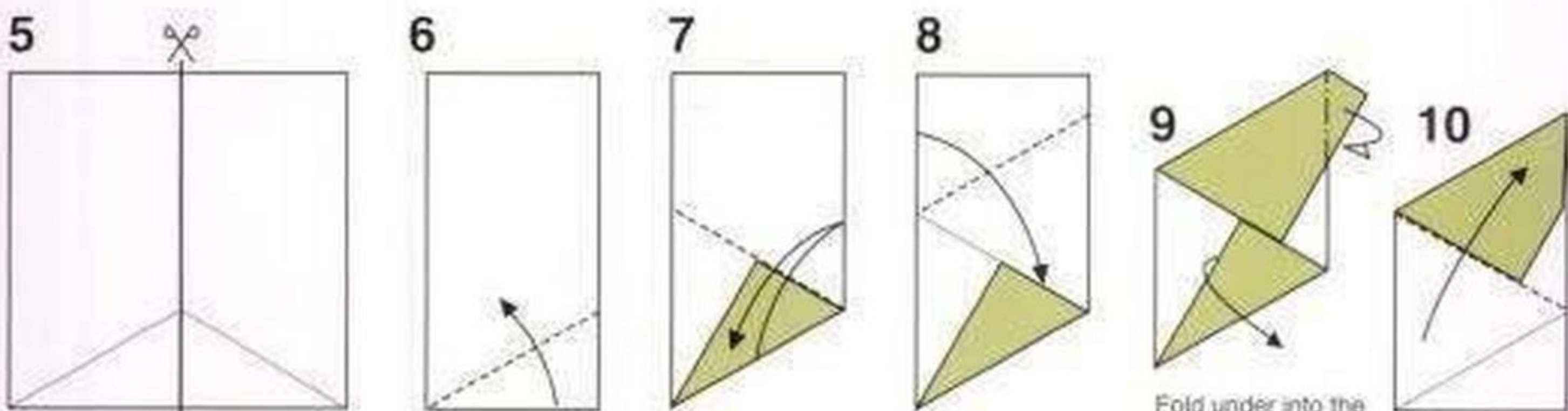

Cut in half.

Fold under into the space between the two layers.

[Assembly Method]

Hexagonal flat unit (p. 34)

Joint C (p. 35)

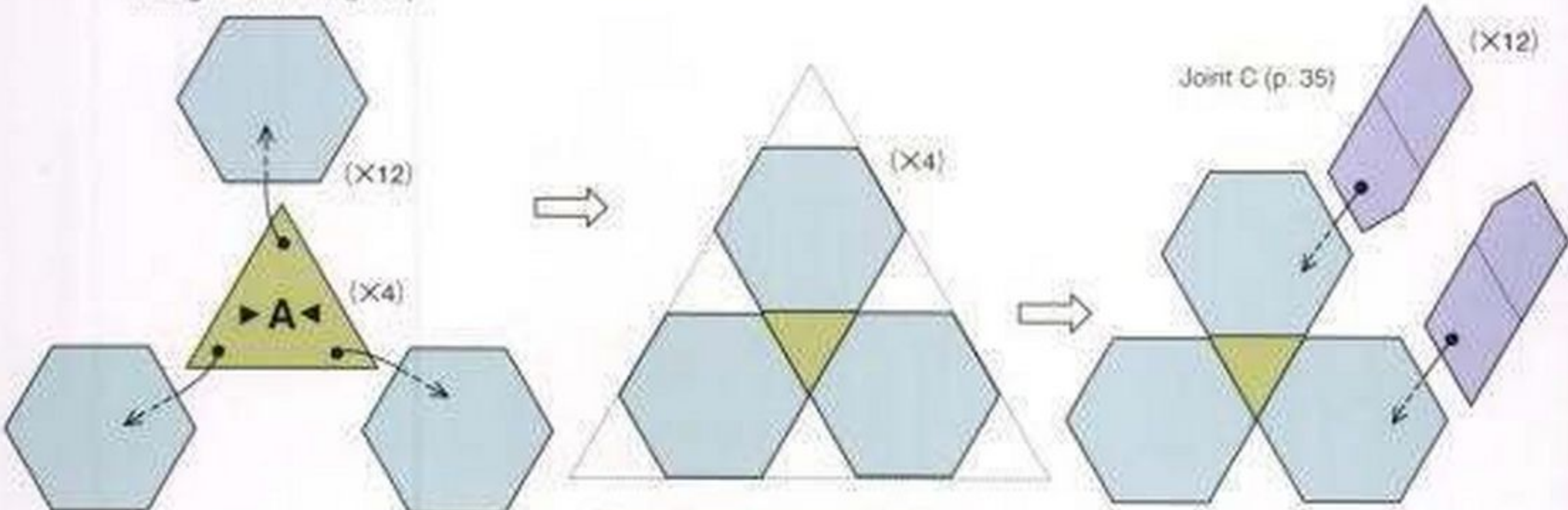

Treat this unit as an equilateral triangle when you assemble the figure.



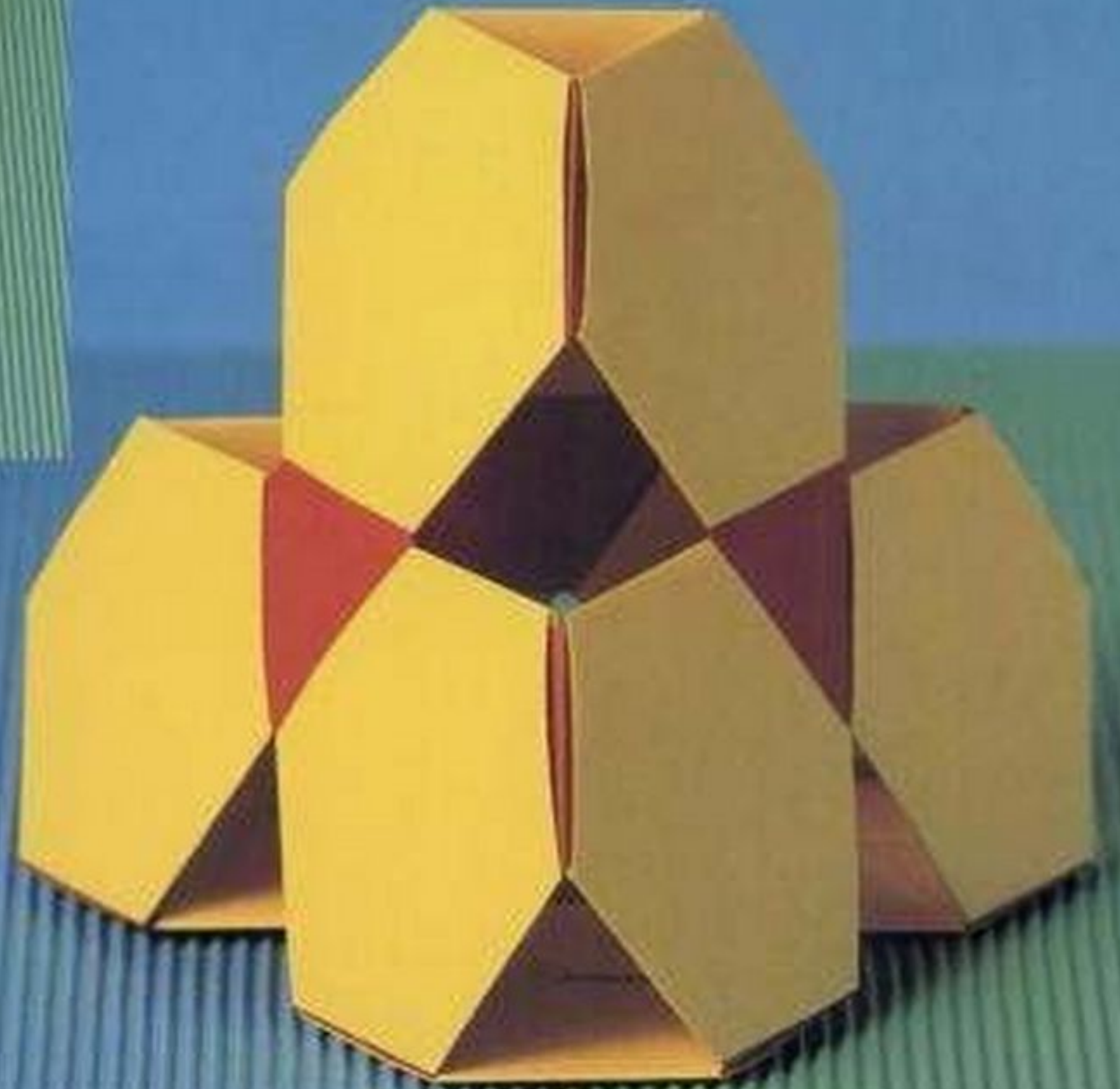
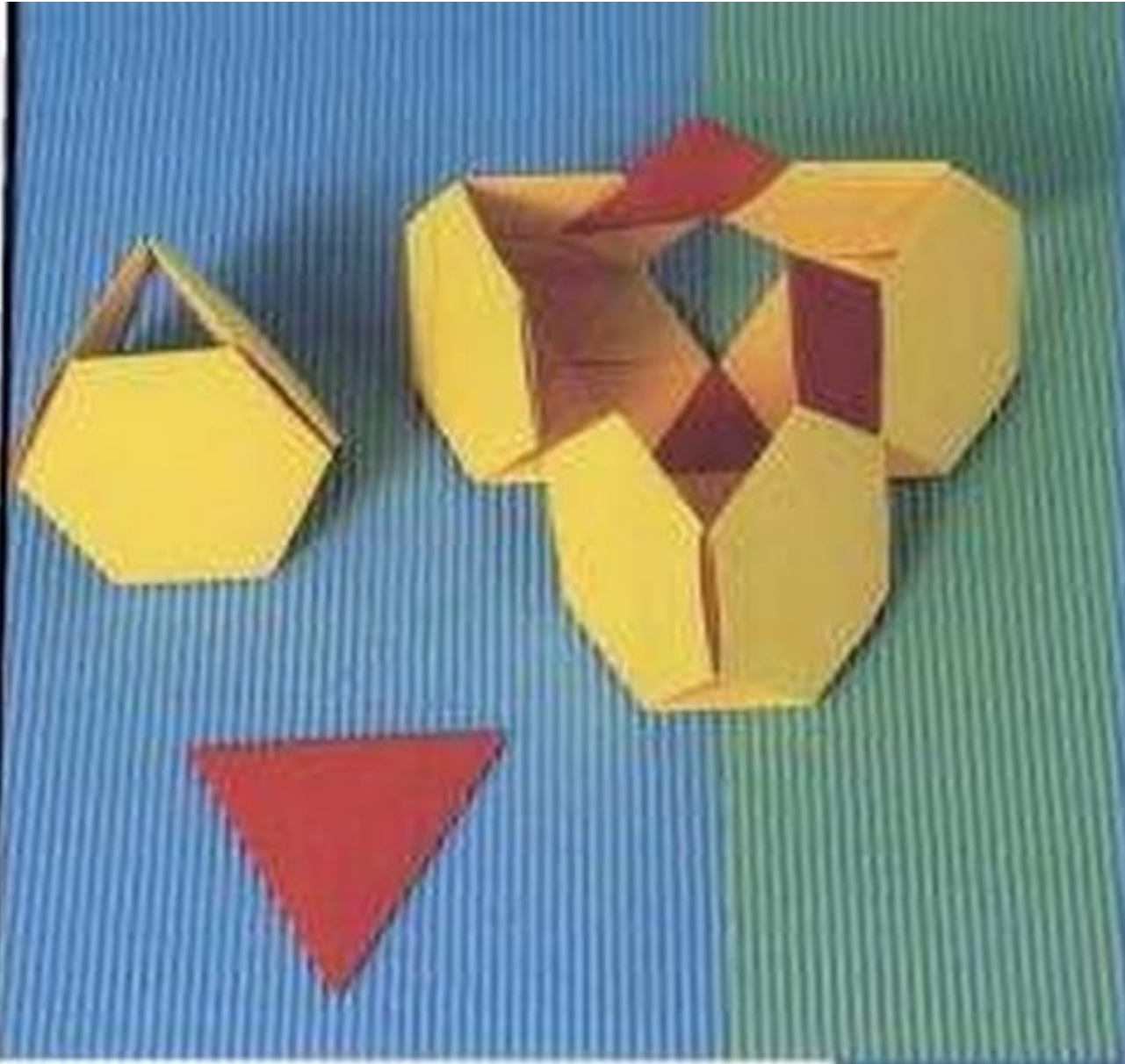

**11** Insert in between the two layers.

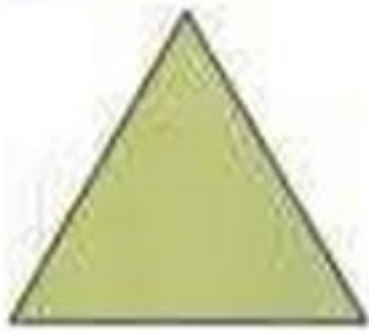
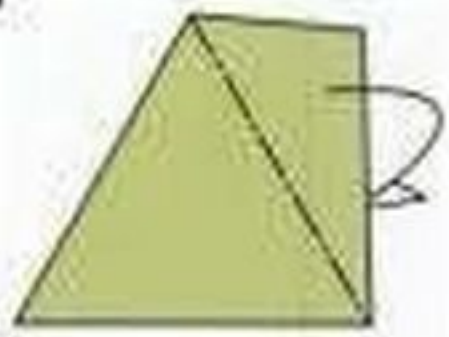

(X4)

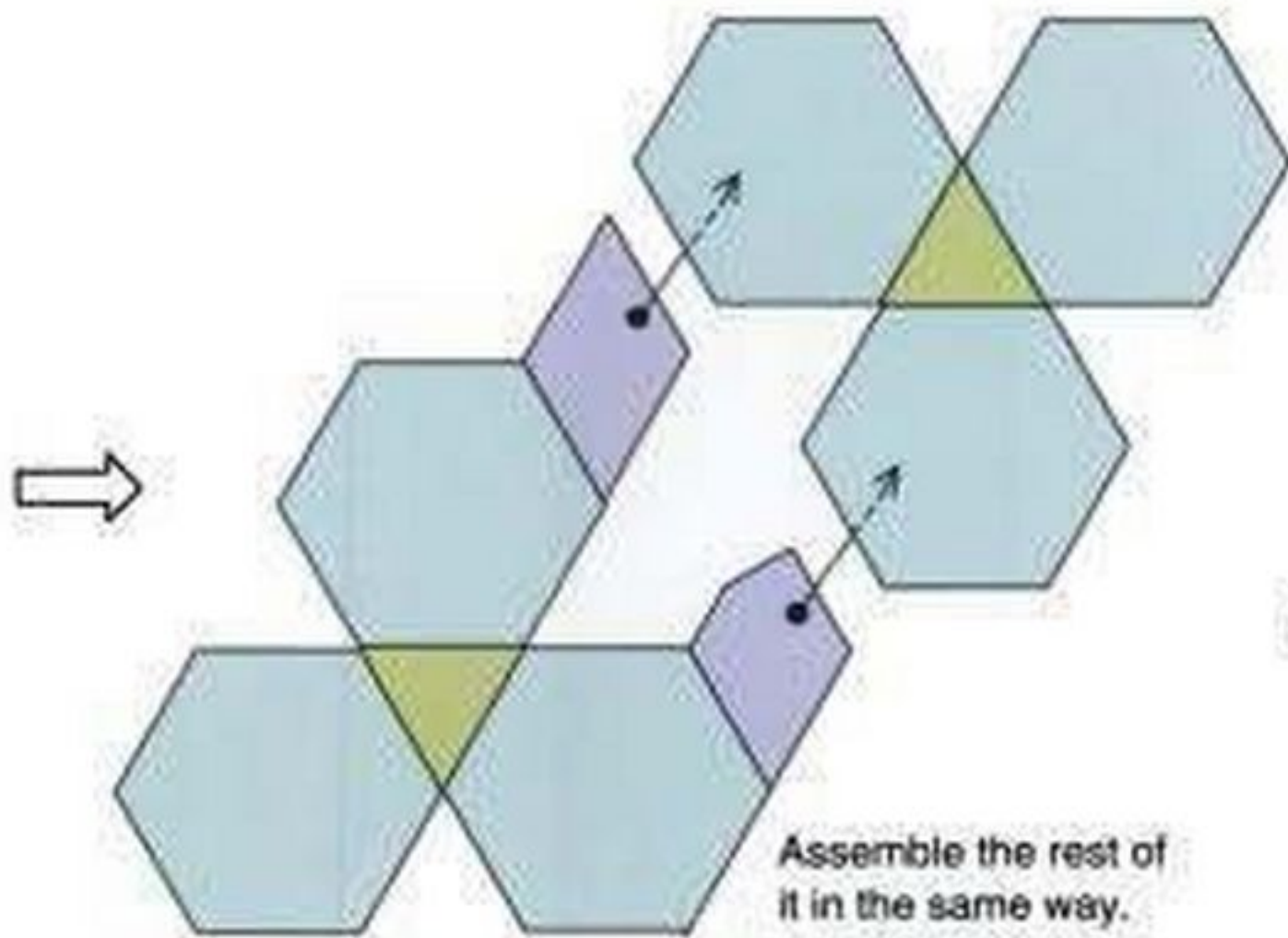

Assemble the rest of it in the same way.

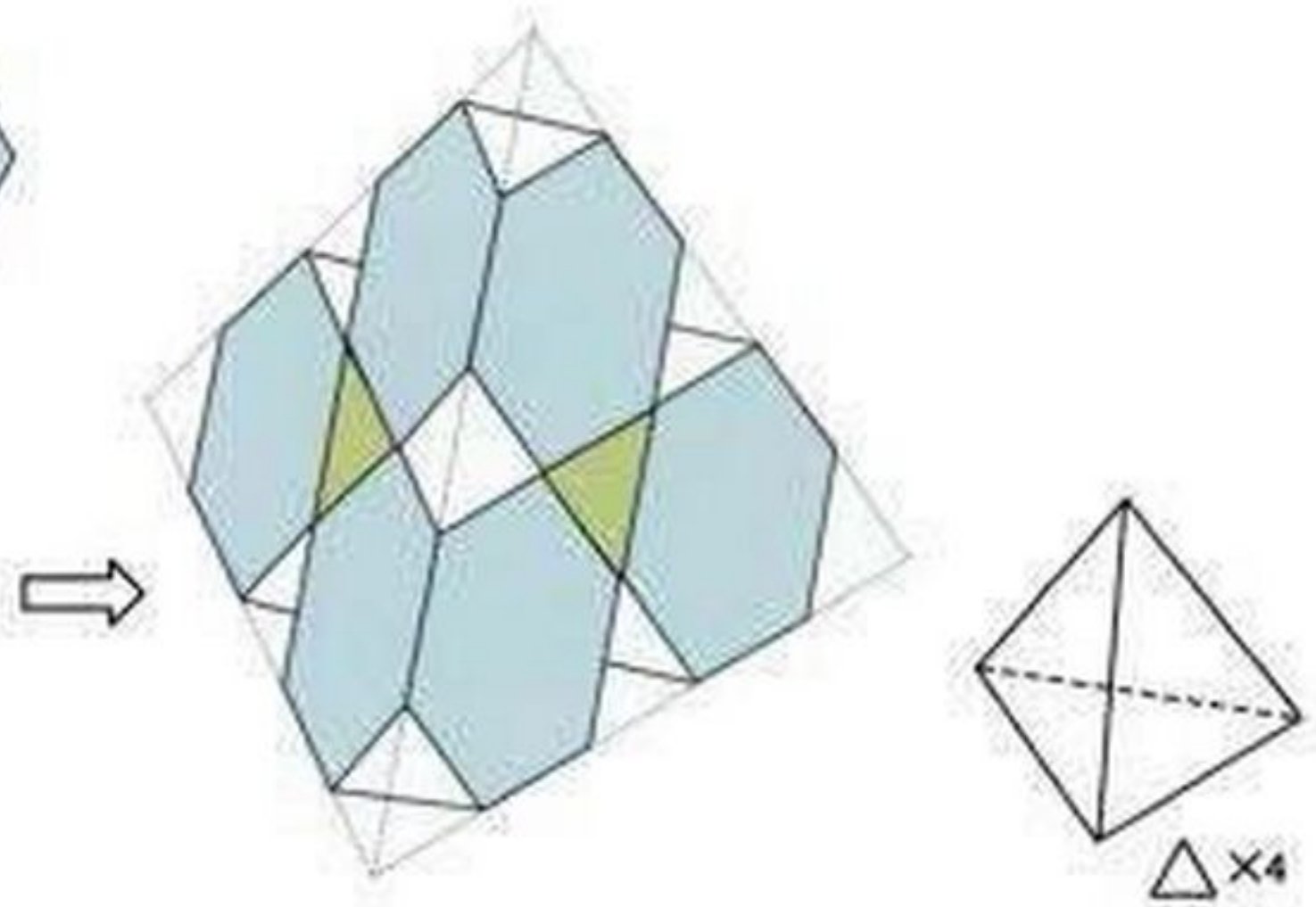



Triangle Element B

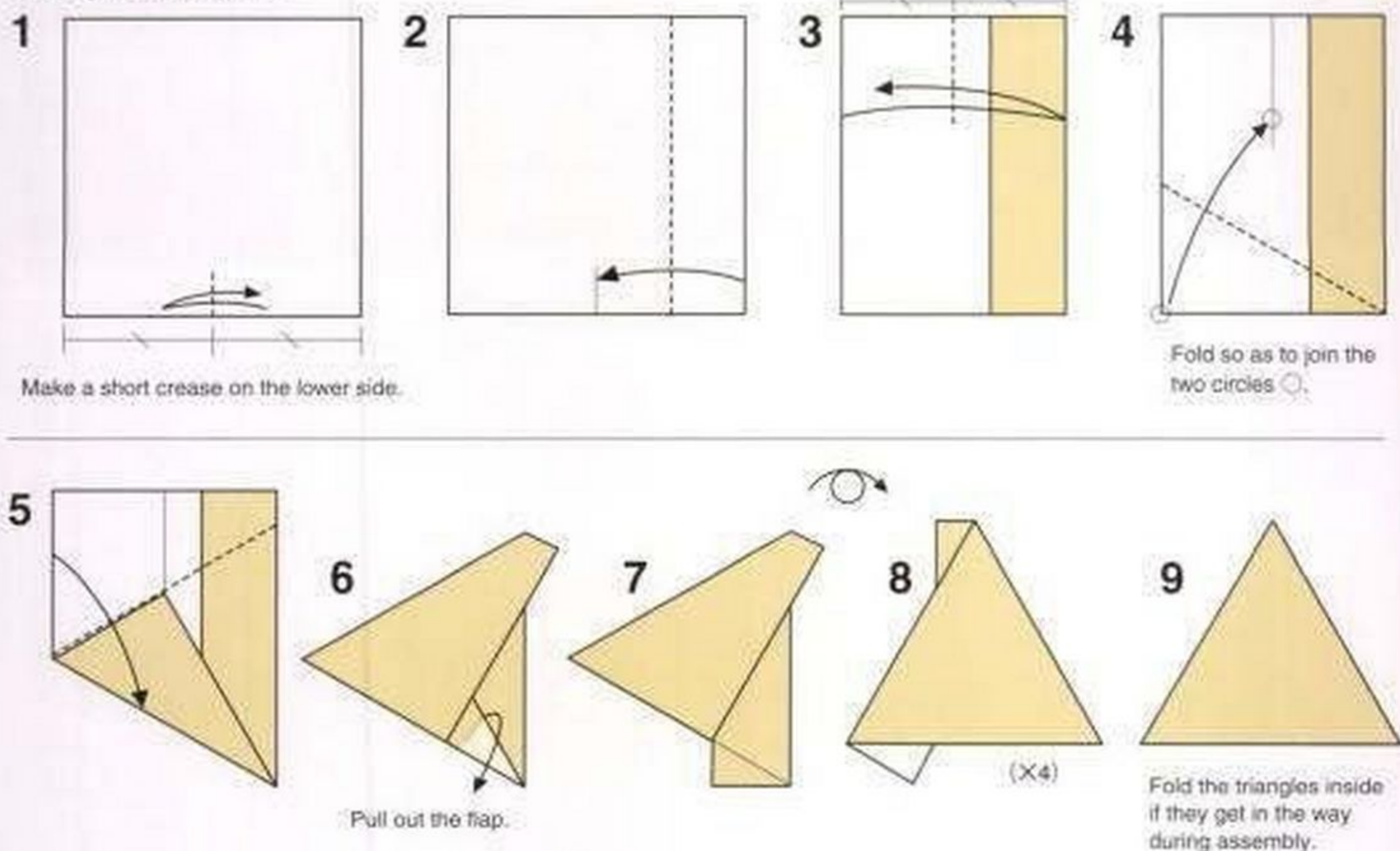

[Assembly Method]

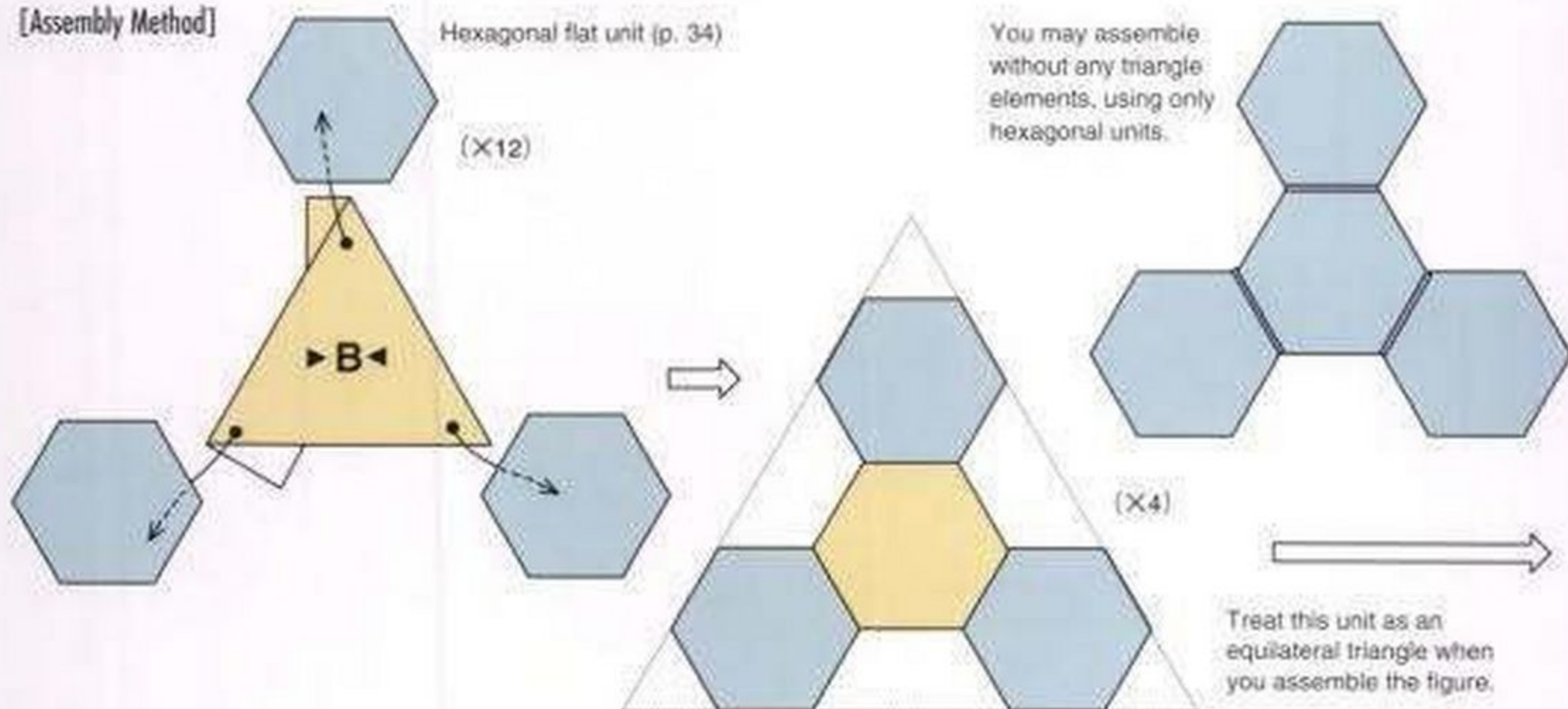



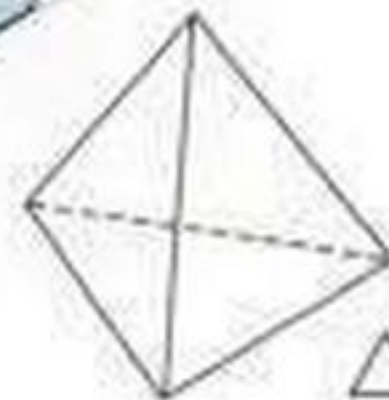
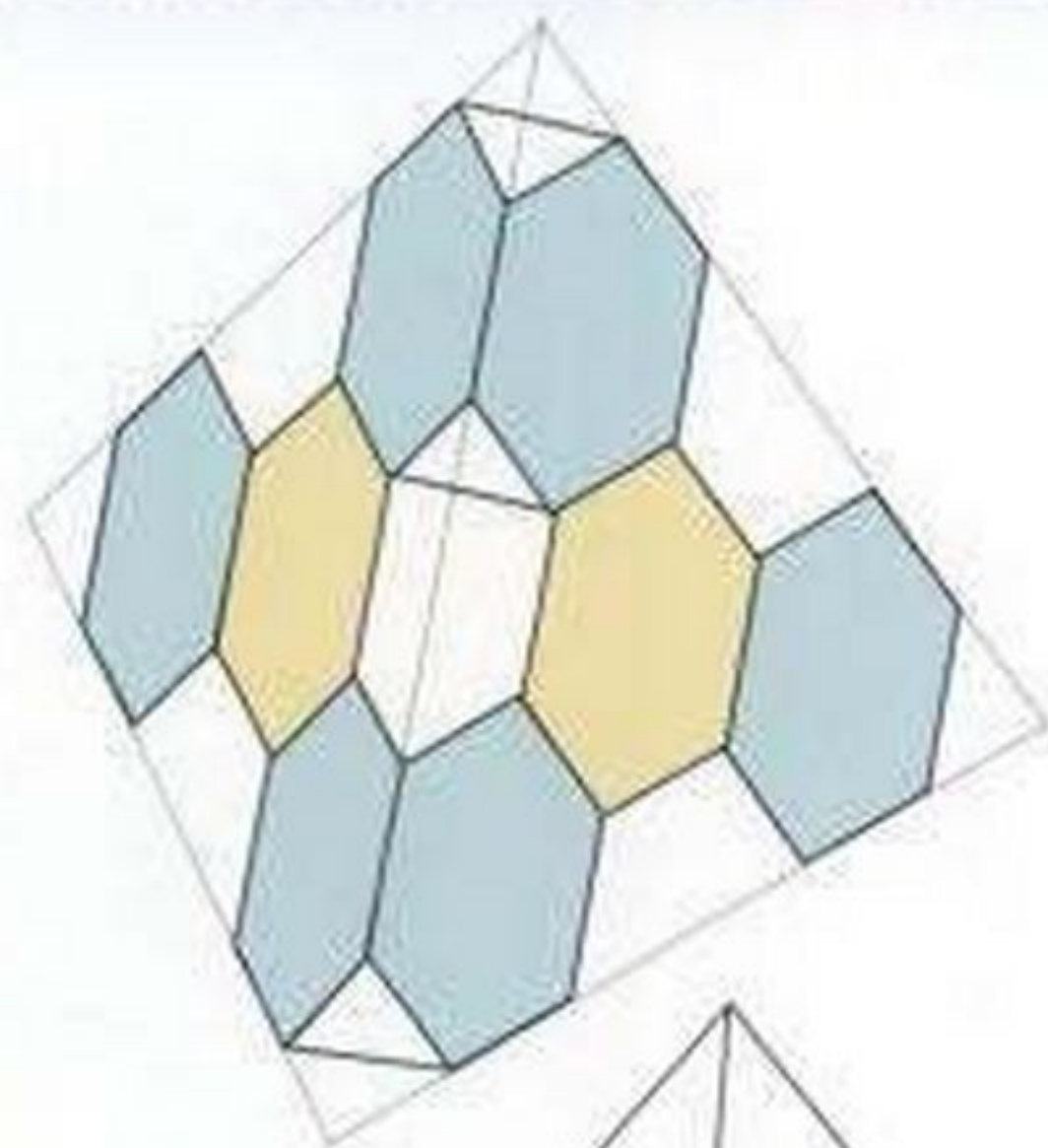
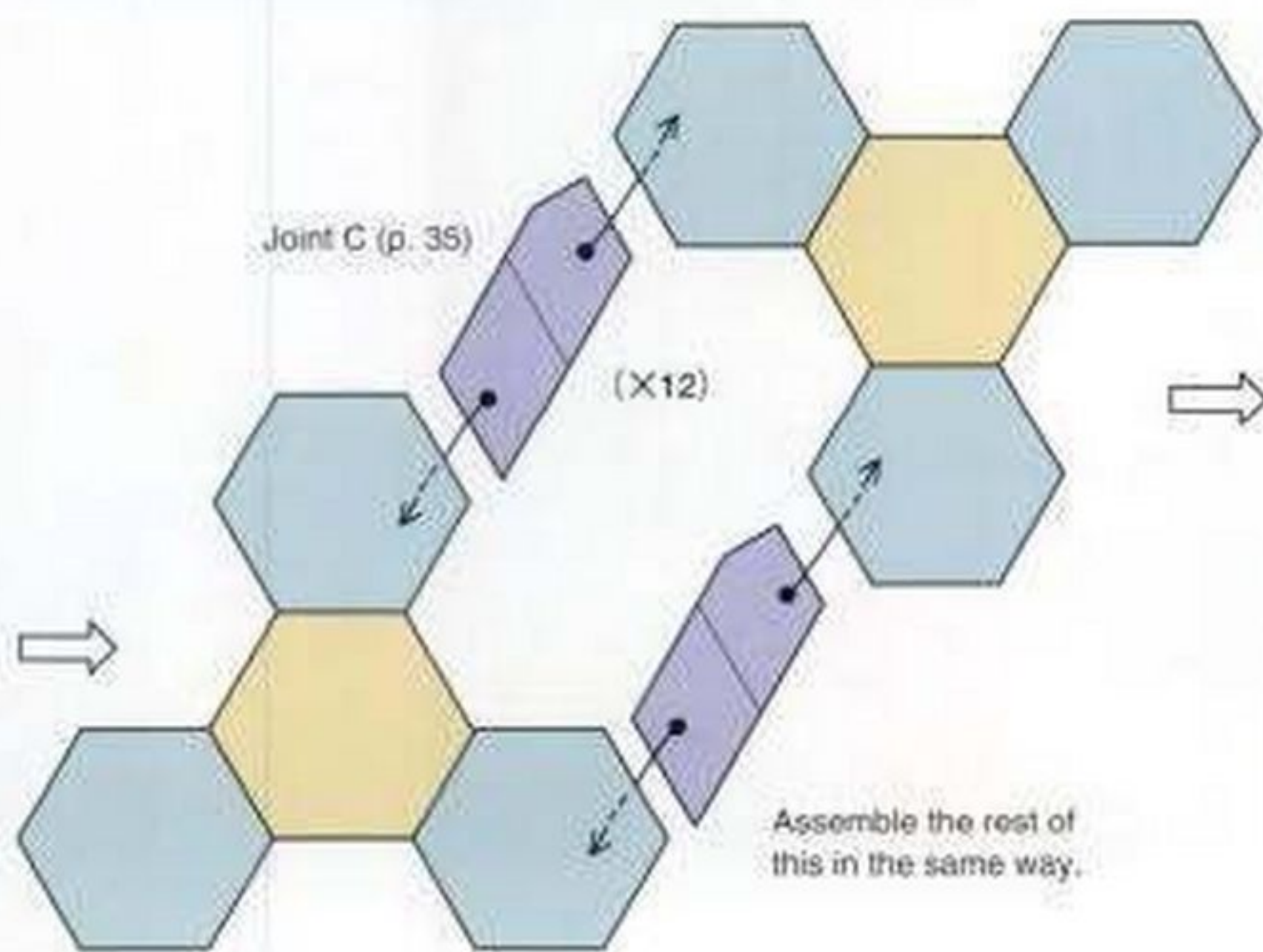
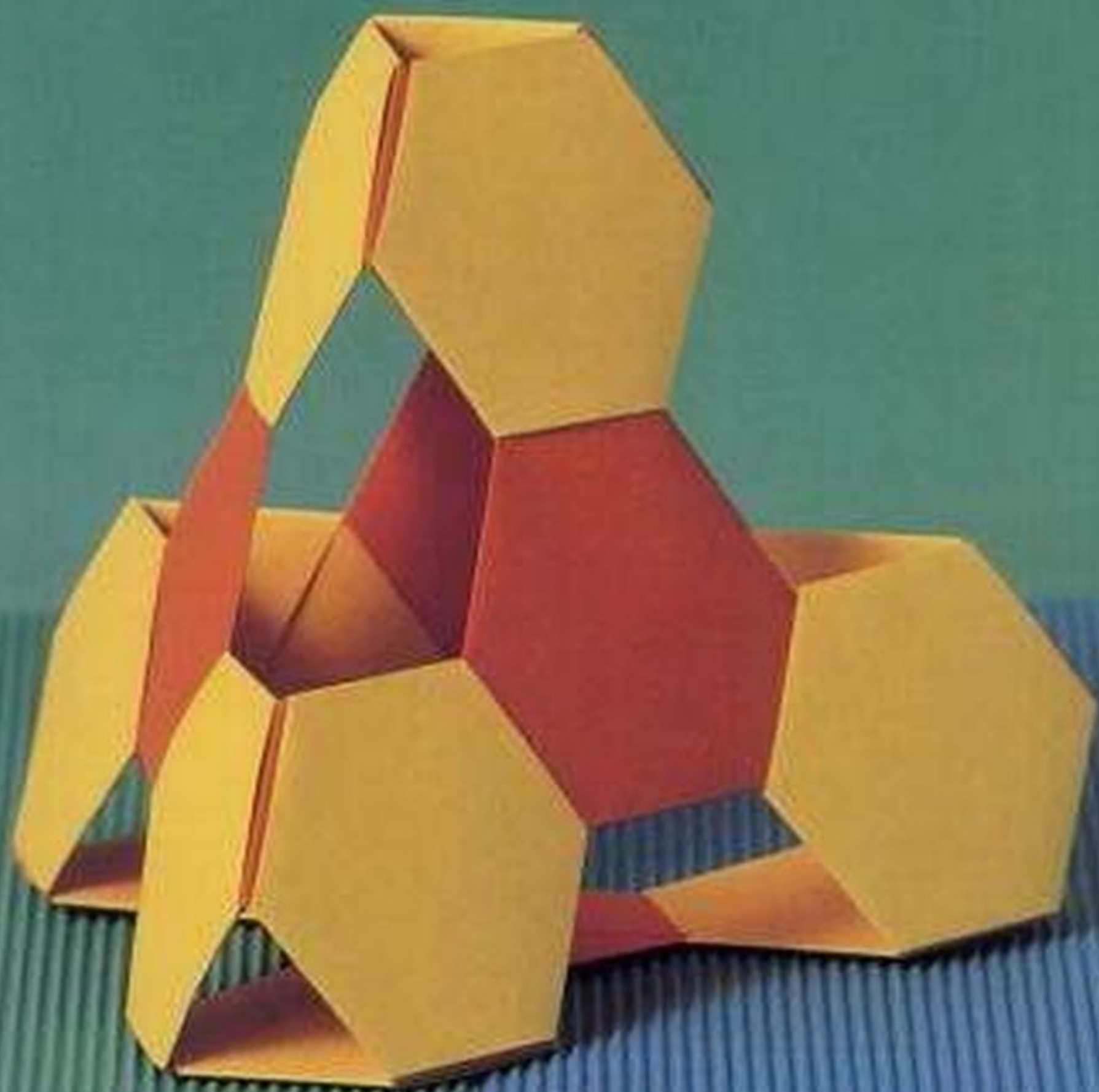



Now you will learn to make structures with two units stacked on top of each other. Using this unit, you can make the solids shown on pp. 38-41 without windows. You can also use it on p. 36.

Hexagonal Flat Unit (Simple Form) (Starting from step 16 on p. 35)

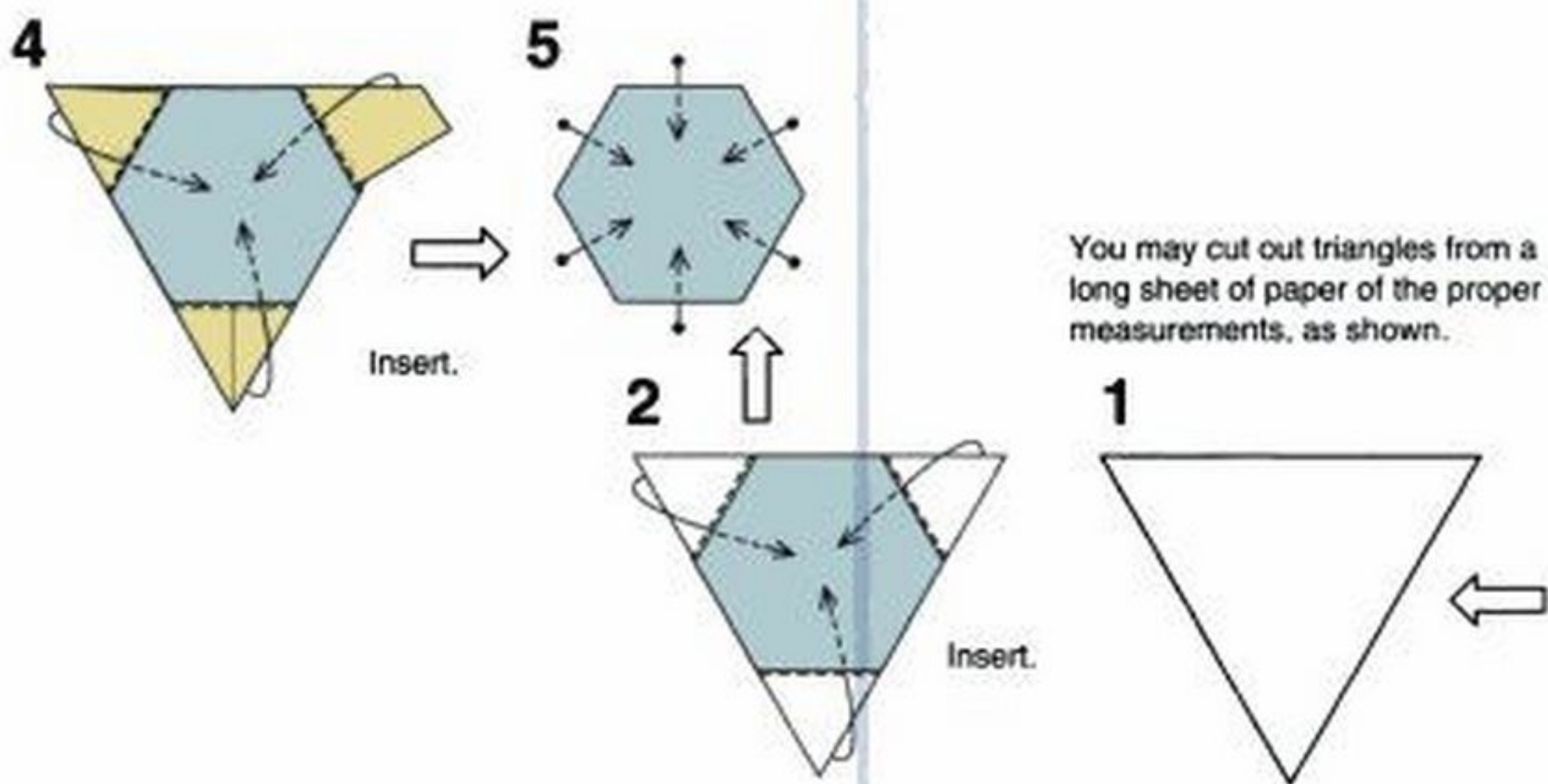
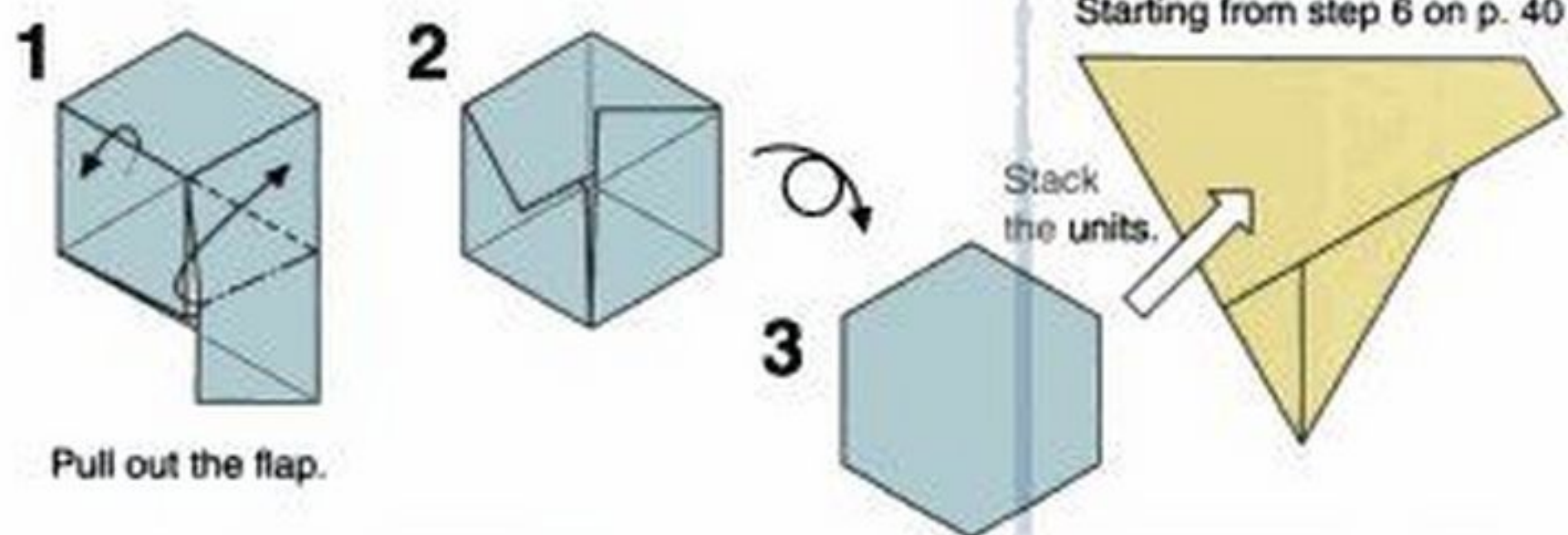

**Triangle Element C**

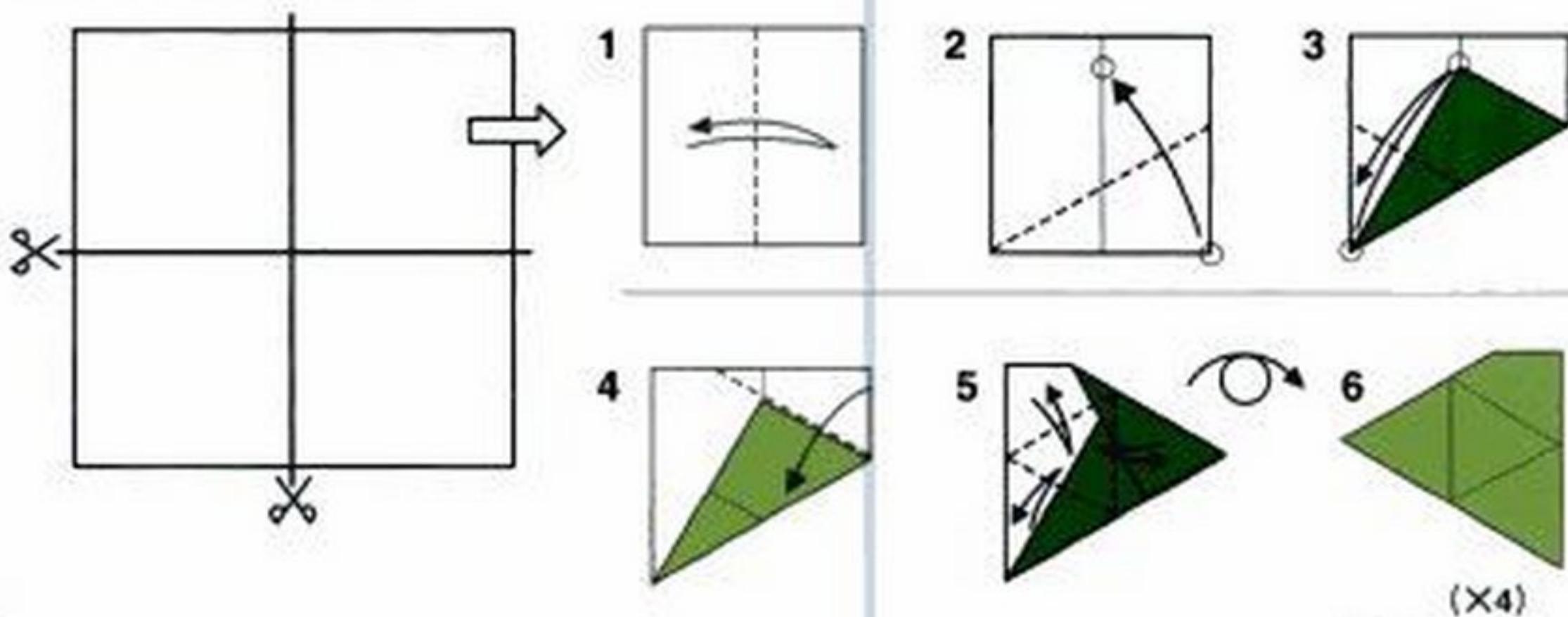

Make a truncated tetrahedron (see p.36) and insert the elements into the triangle windows.



TETRAHEDRON

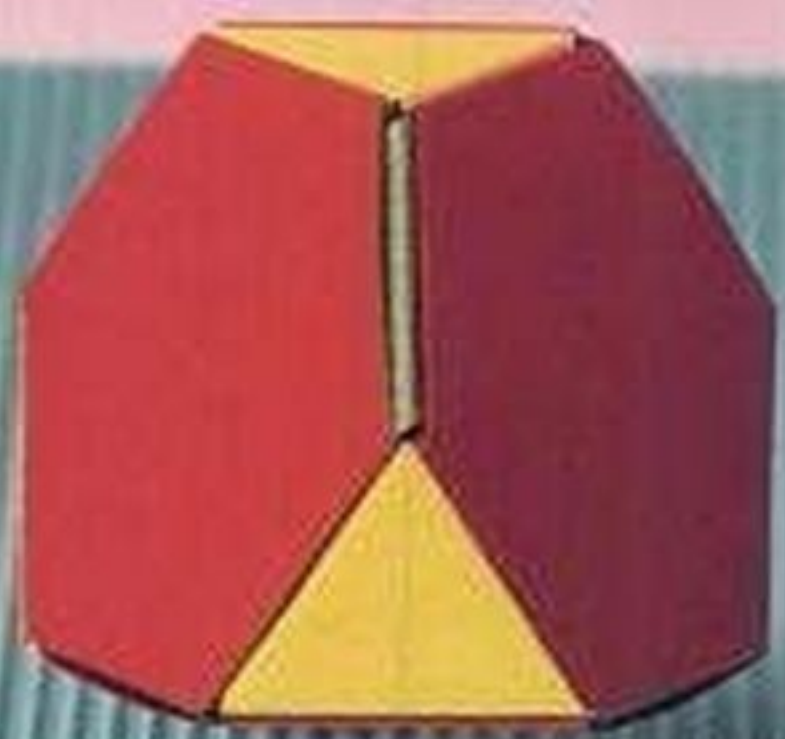

OCTAHEDRON

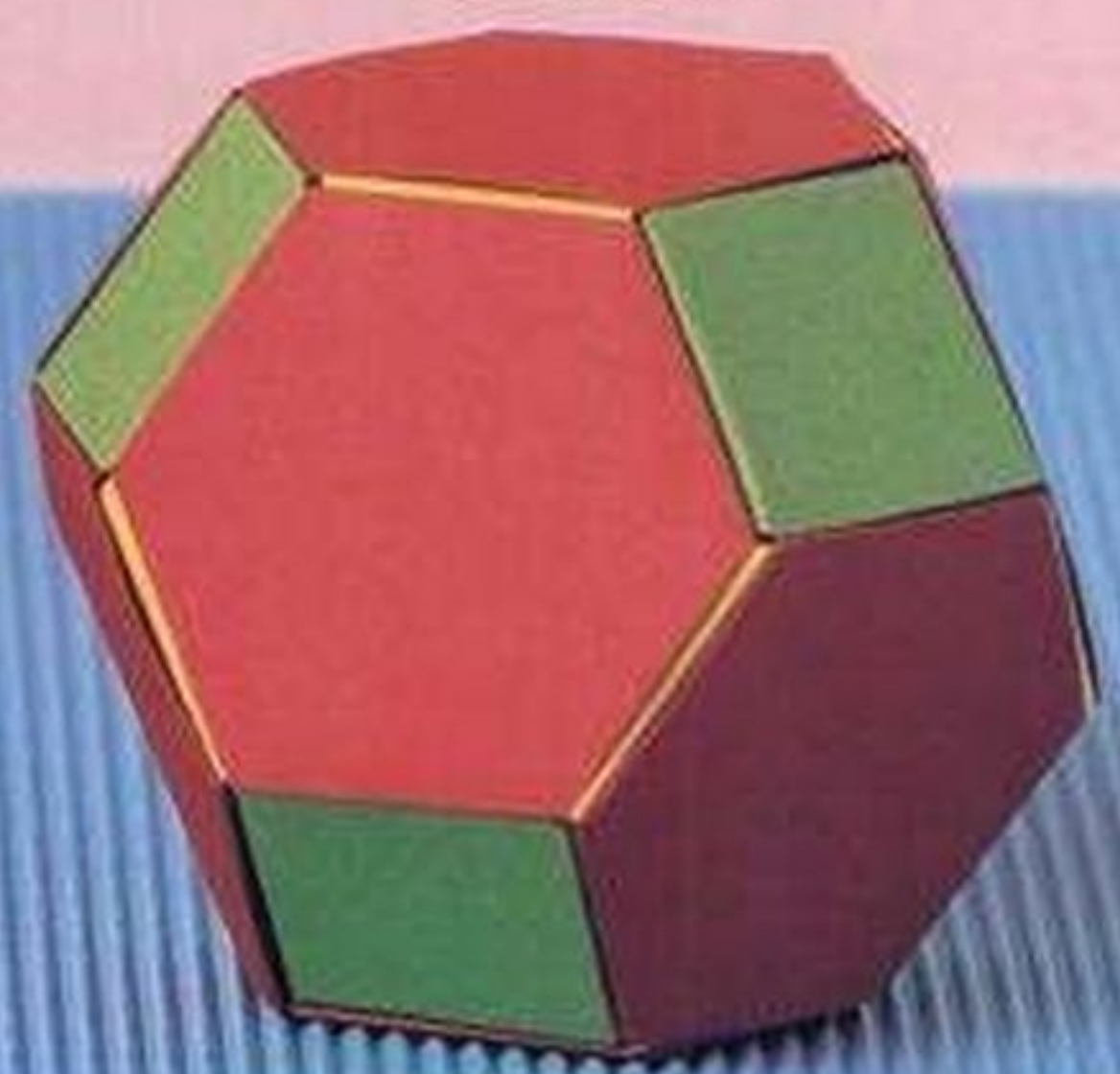

Square Element

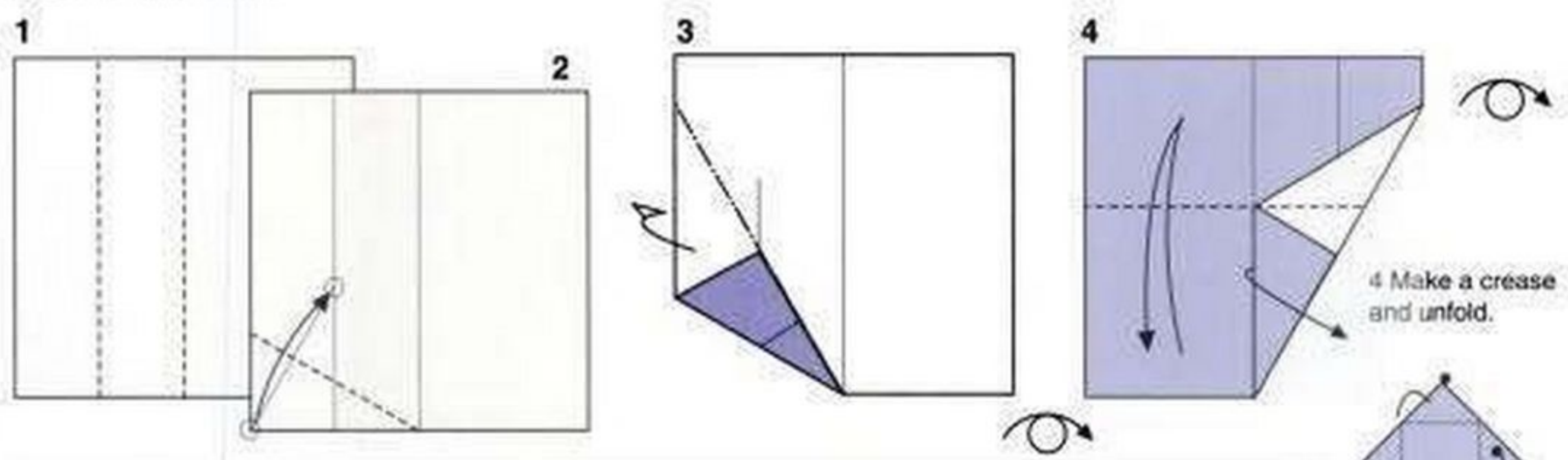

4 Make a crease and unfold.

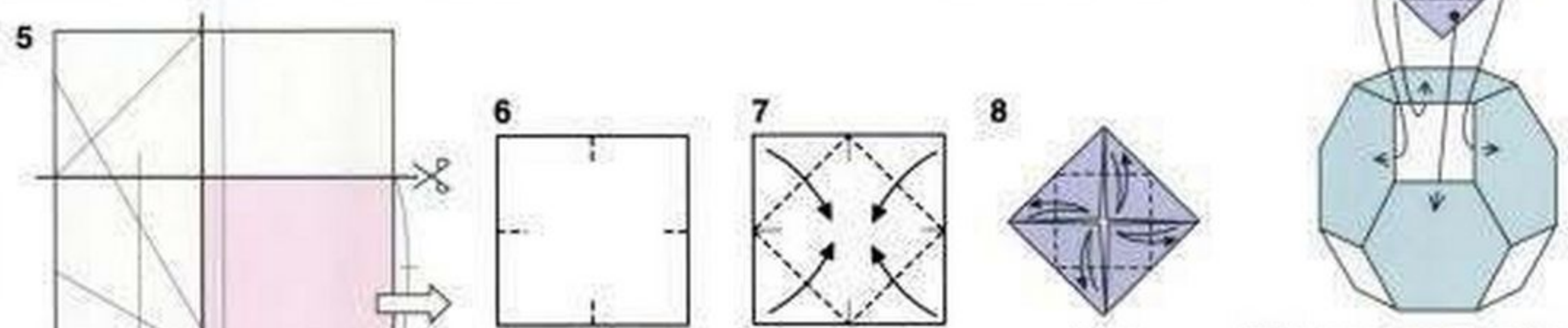

(X6)

Make a truncated octahedron (see p. 36) and insert the elements into the square windows.



# 5

## EDGE CUBES

These cubes are assembled by connecting them at twelve places. There are square or star-shaped windows in the middle of each surface. Modifying the folds and measurements changes the cubes and the size of the windows.

**STAR-SHAPED WINDOWS - Large** /p.48



**STAR-SHAPED WINDOWS - Medium** /p.51

**SQUARE WINDOWS - Medium** /p.45



**SQUARE WINDOWS - Large** /p.47



**SQUARE WINDOWS - Small** /p.46



**STAR-SHAPED WINDOWS - Small** /p.50



This cube is assembled by joining the sides. Changing the folds and the measurements changes the size of the windows.

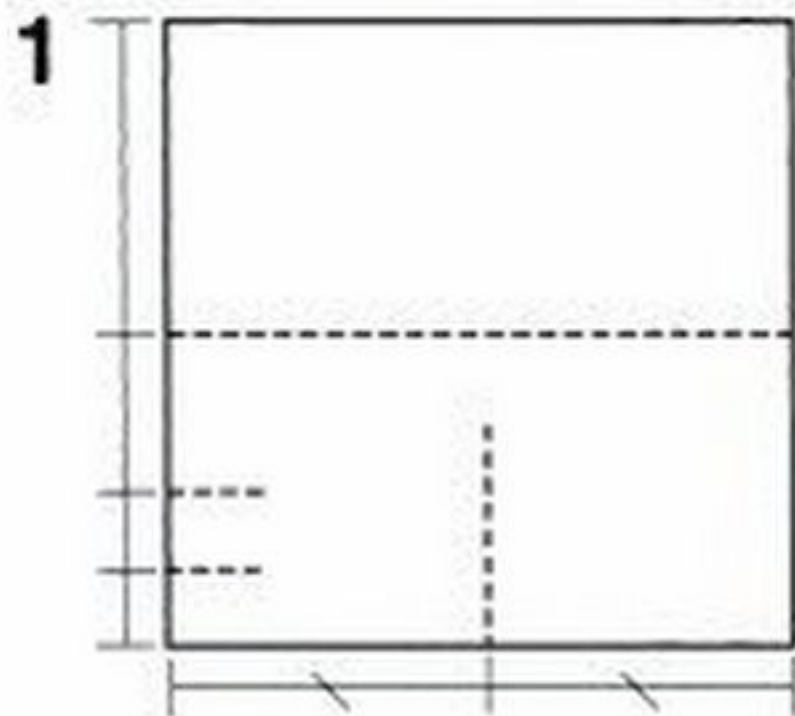

Make creases as shown.

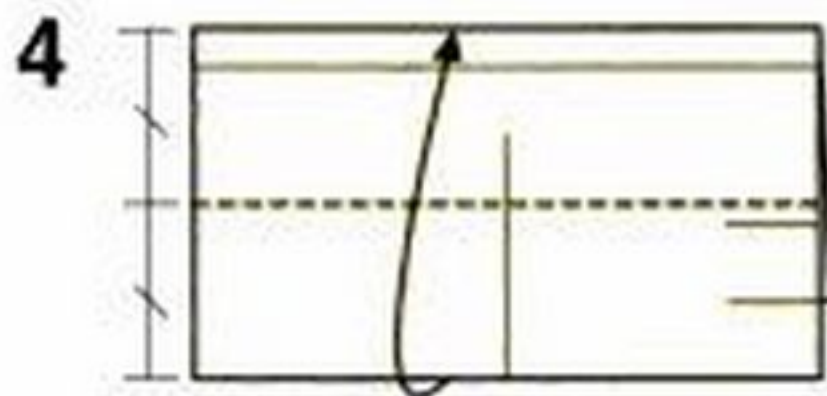
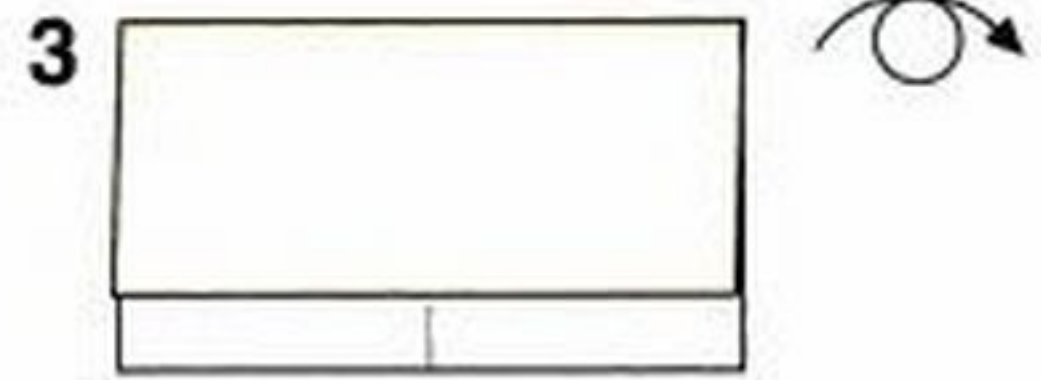
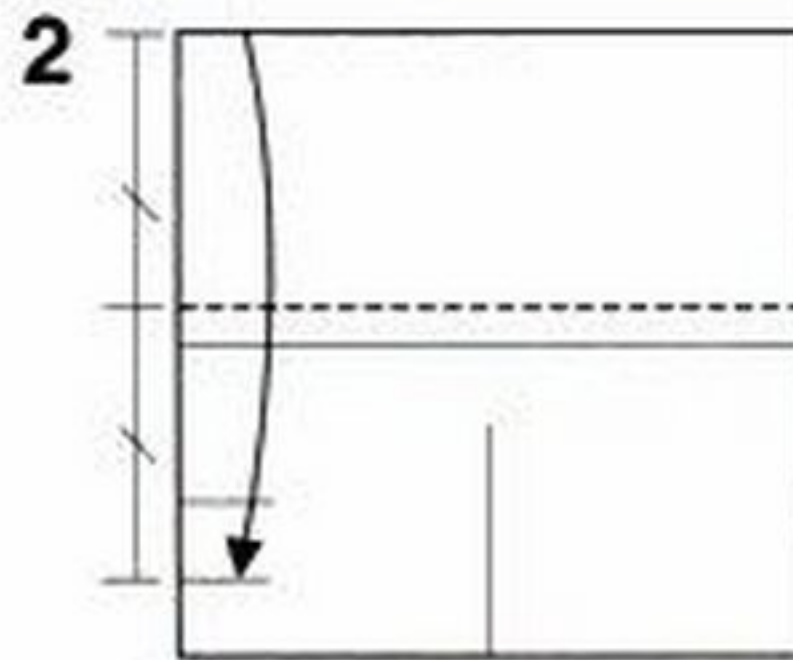

Align the edges and fold.

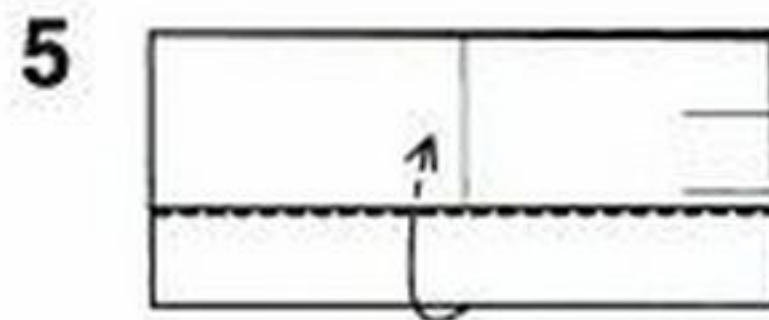

Fold the edge under the flap.

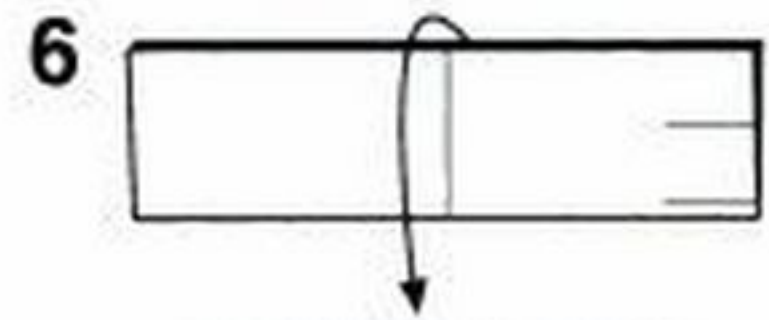

Unfold the upper layer.

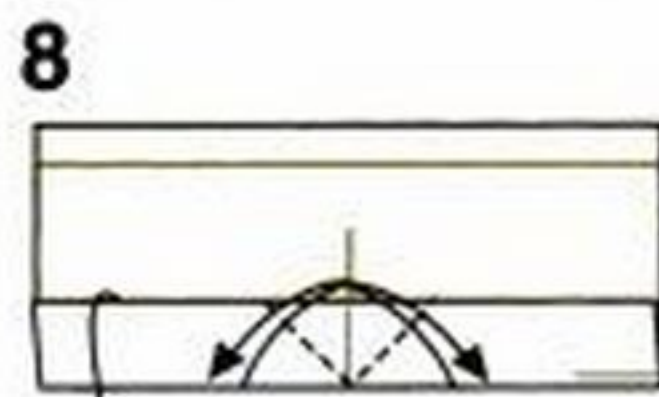
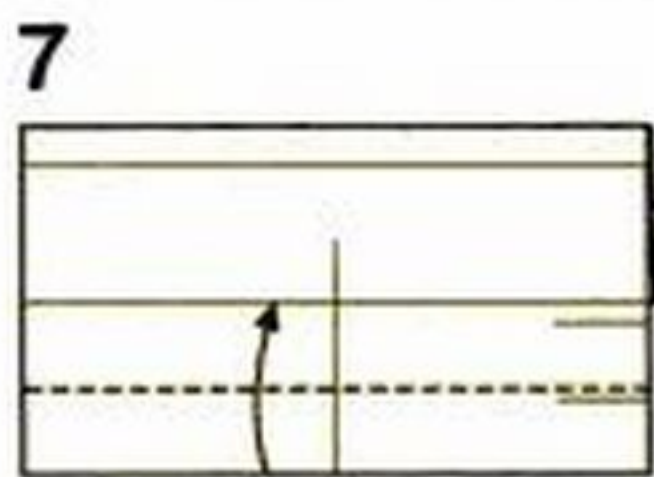

Make creases and unfold.

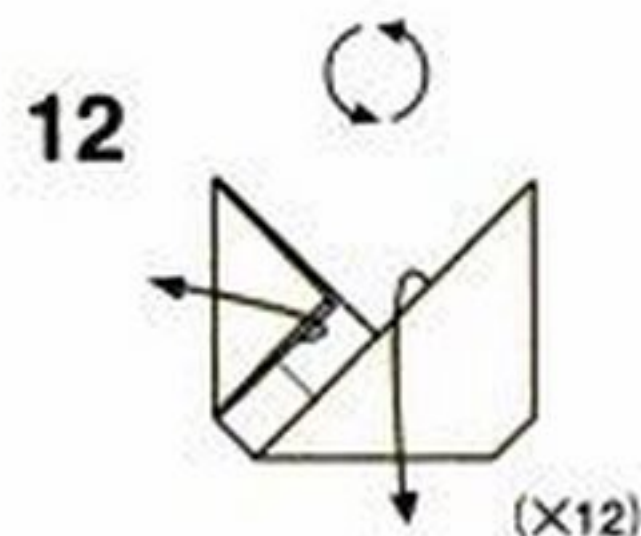
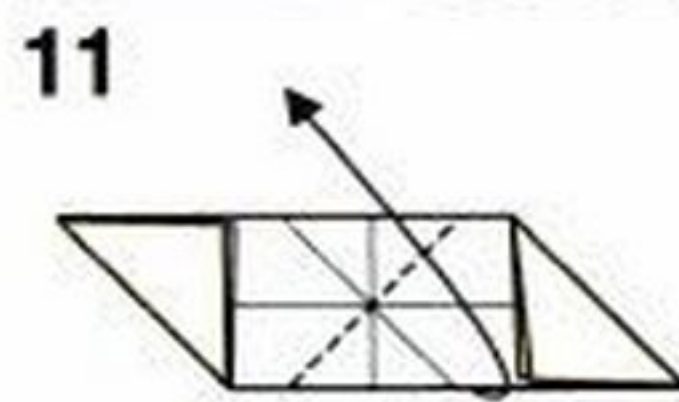
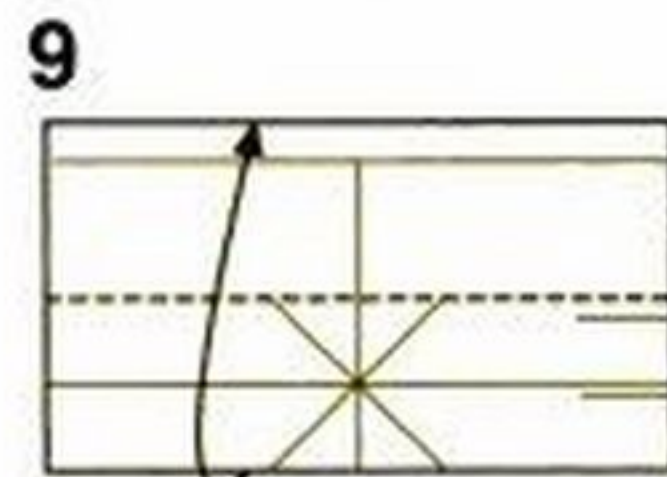

(X12)

[Assembly Method]

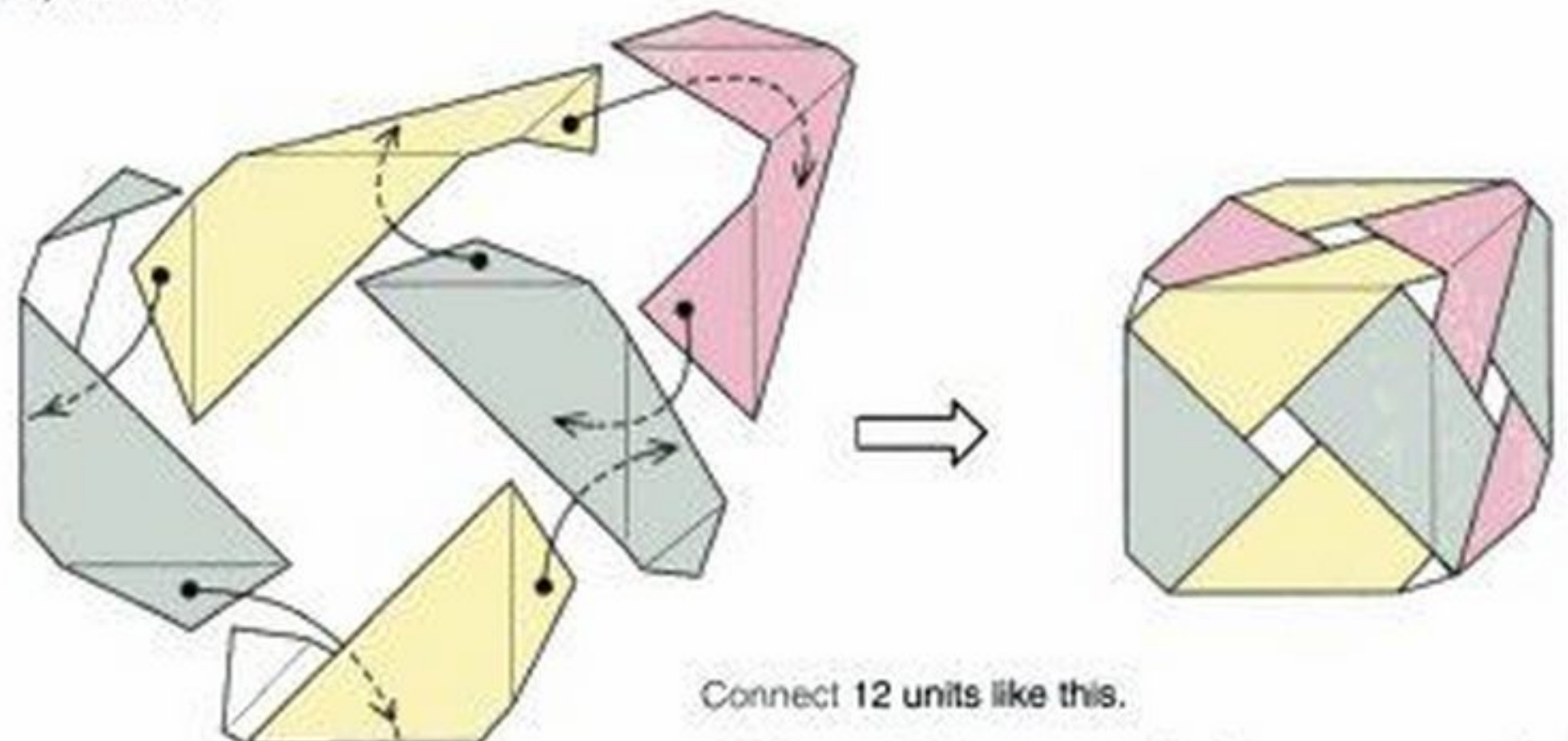

Connect 12 units like this.



A cube assembled by connecting sides. Changing the folds and the measurements changes the size of the windows.

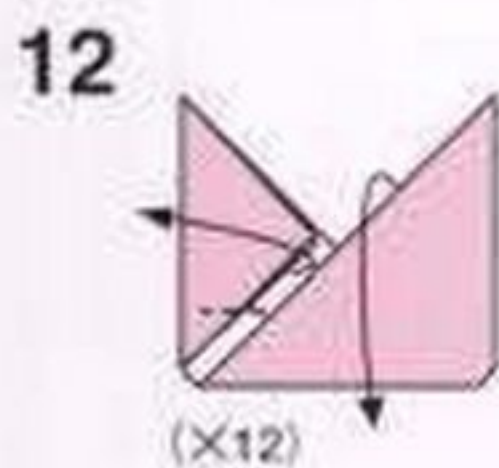
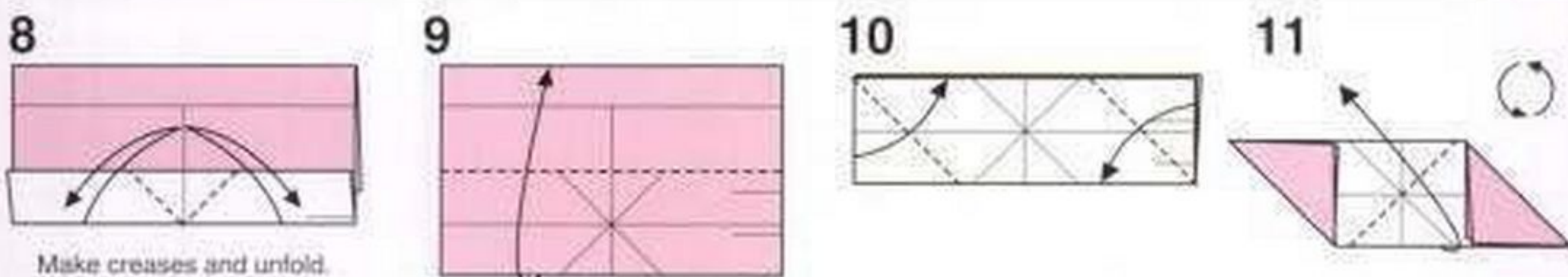
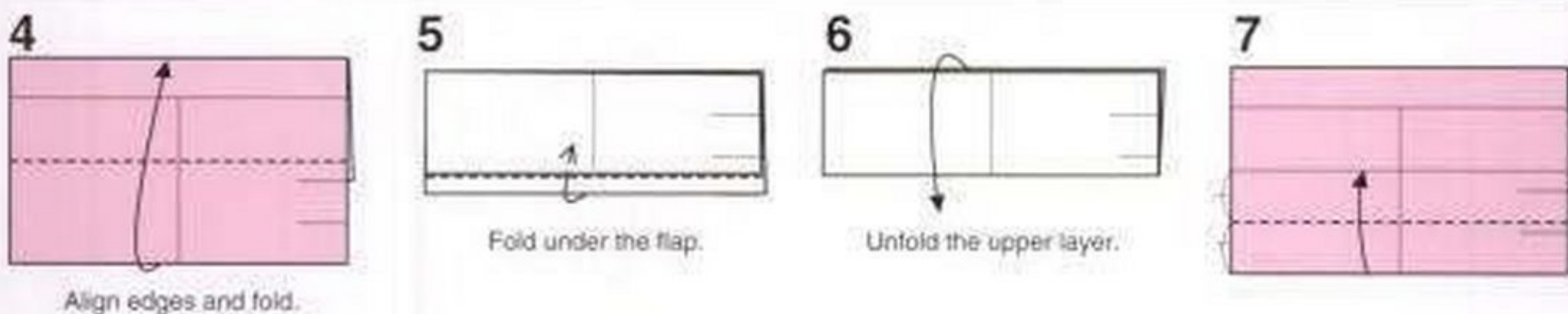
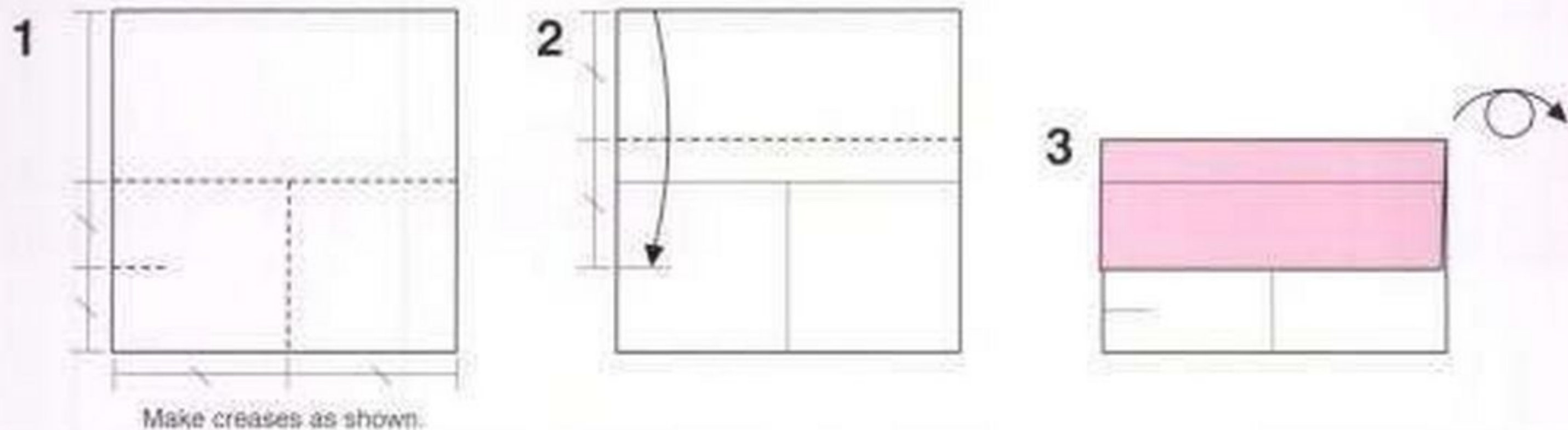

Assemble in the same way as the medium cube. (p. 45)





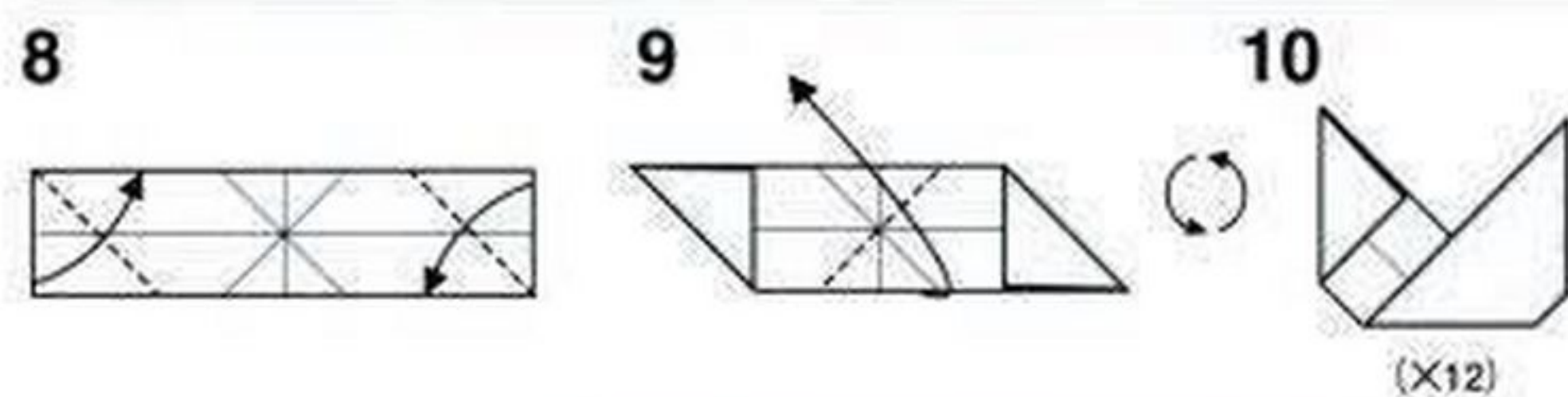
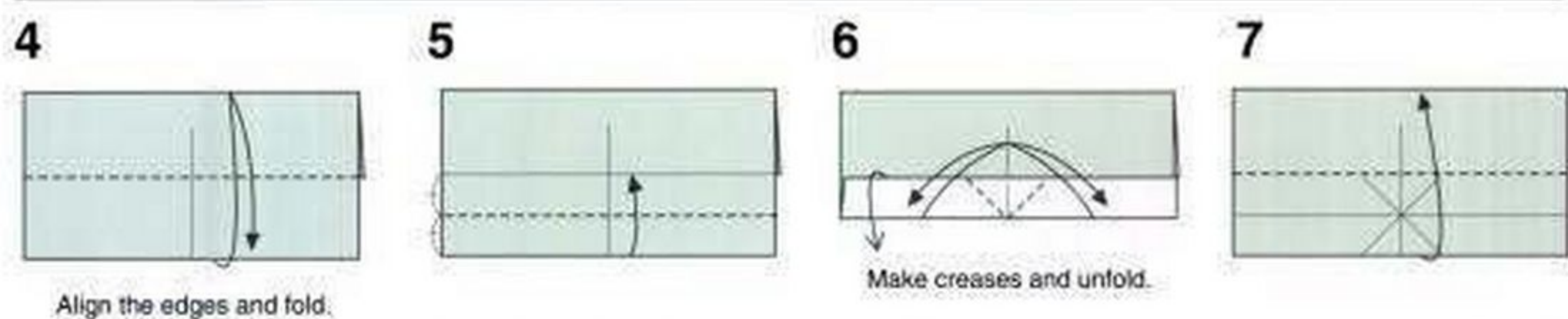
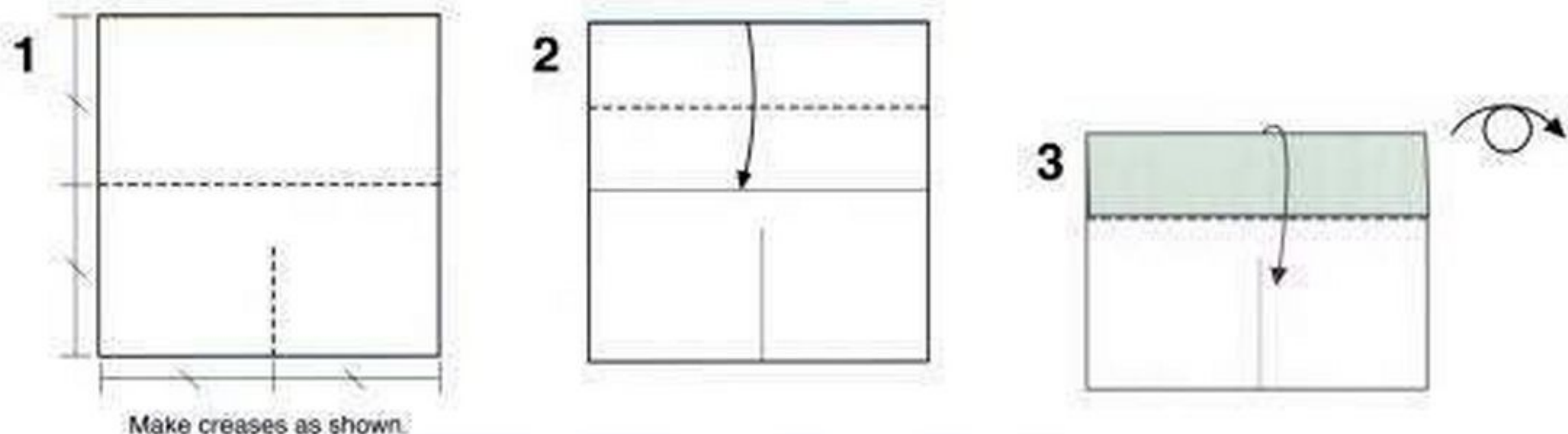

Assemble in the same way as the medium cube. (p. 45)





A cube with star-shaped windows. Changing the folds and the measurements changes the size of the windows.

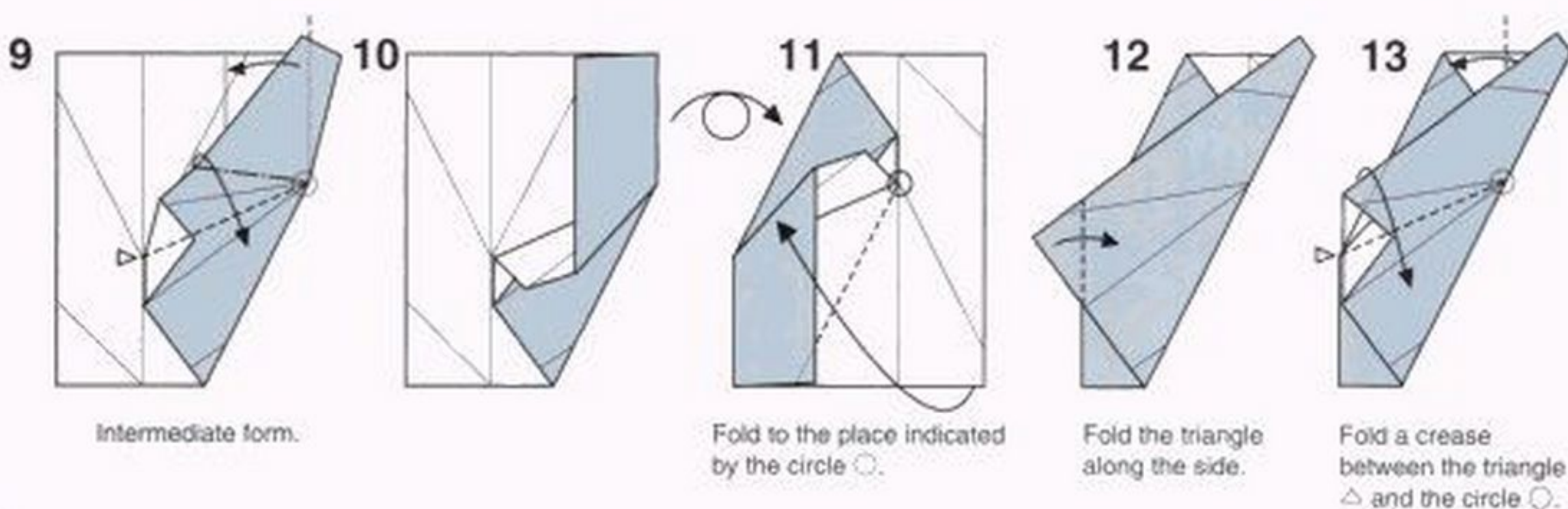
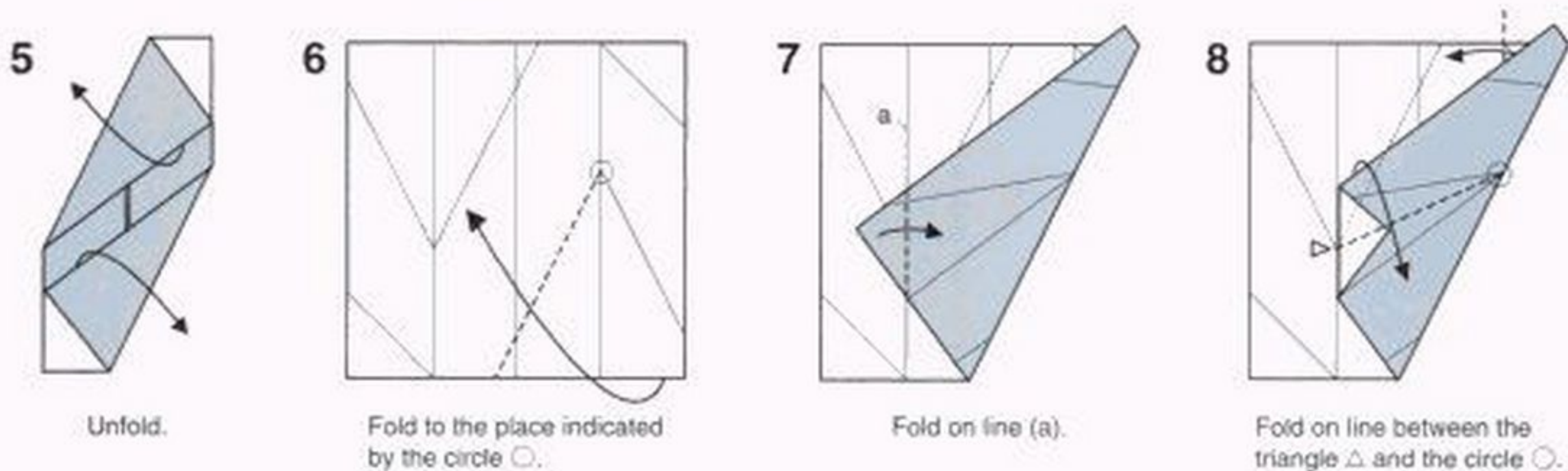
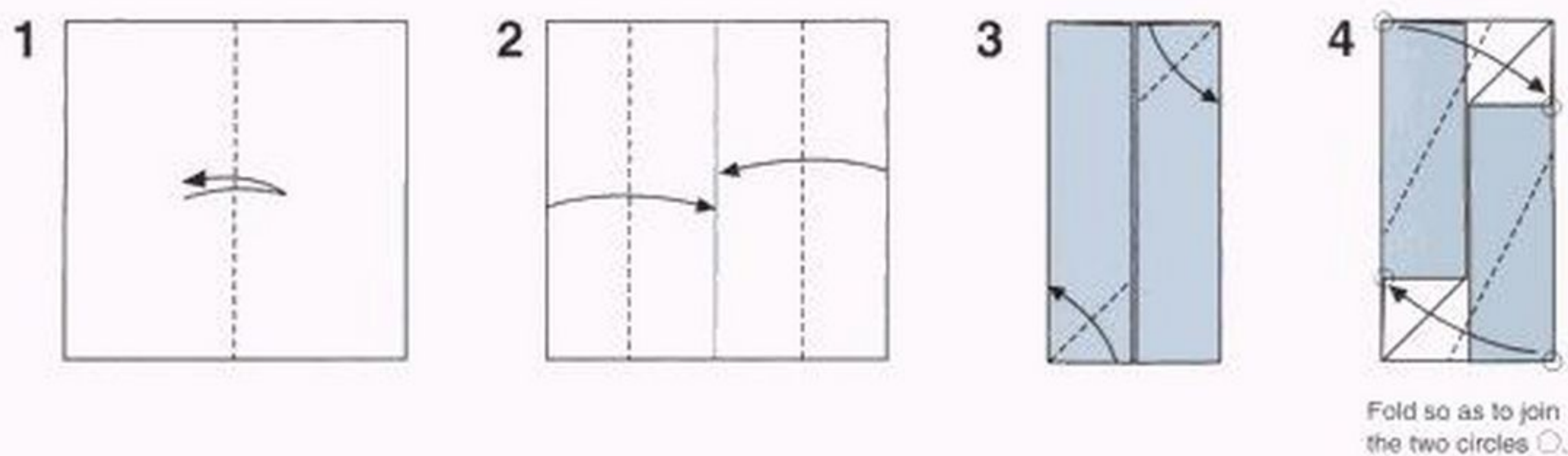



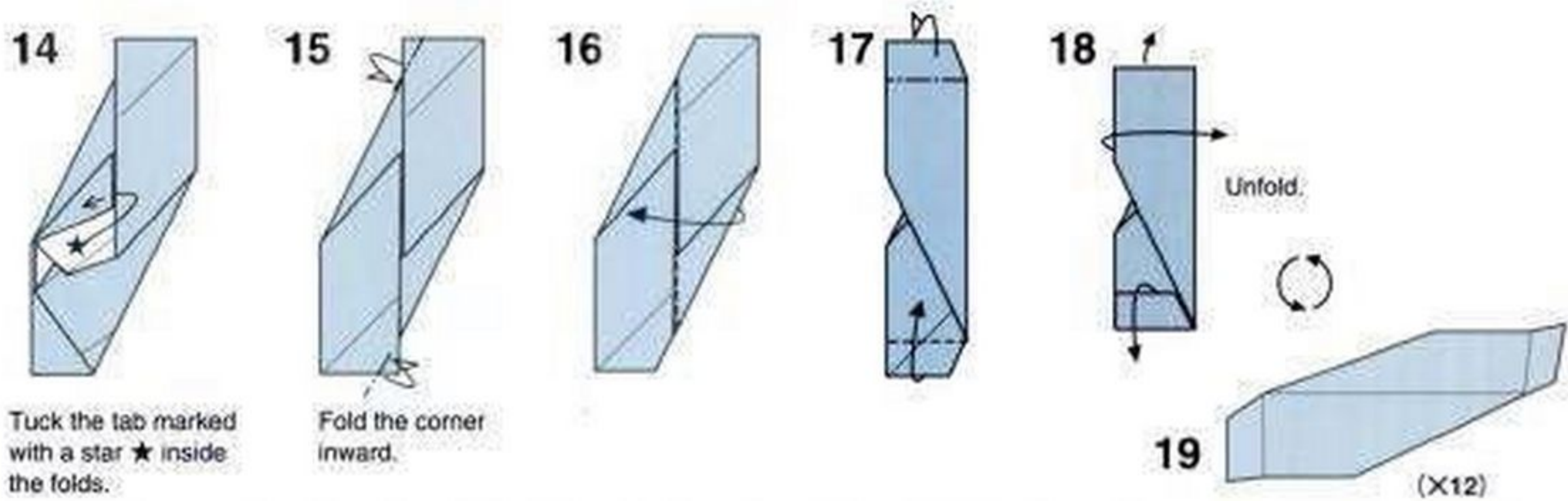

[Assembly Method]

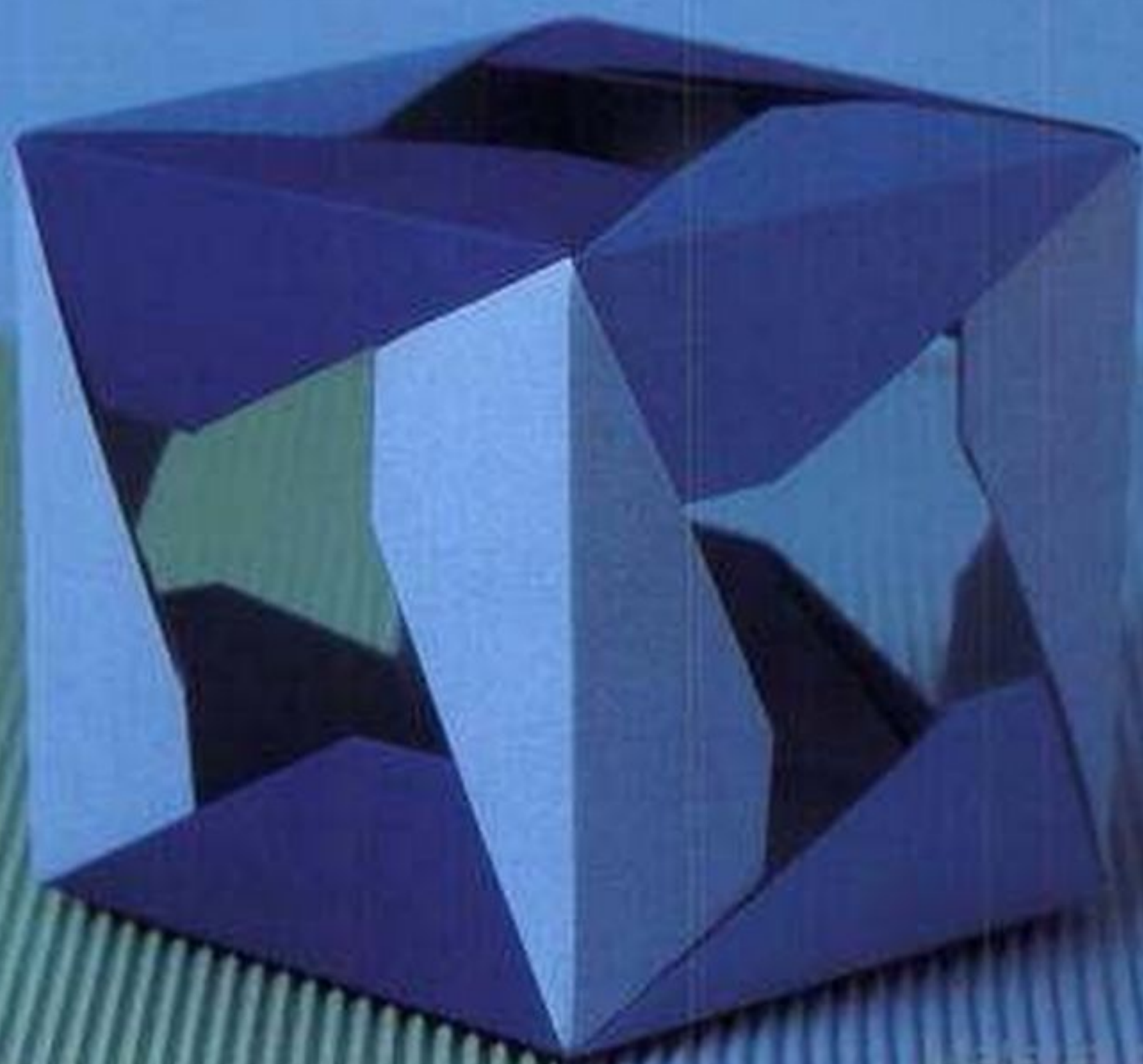
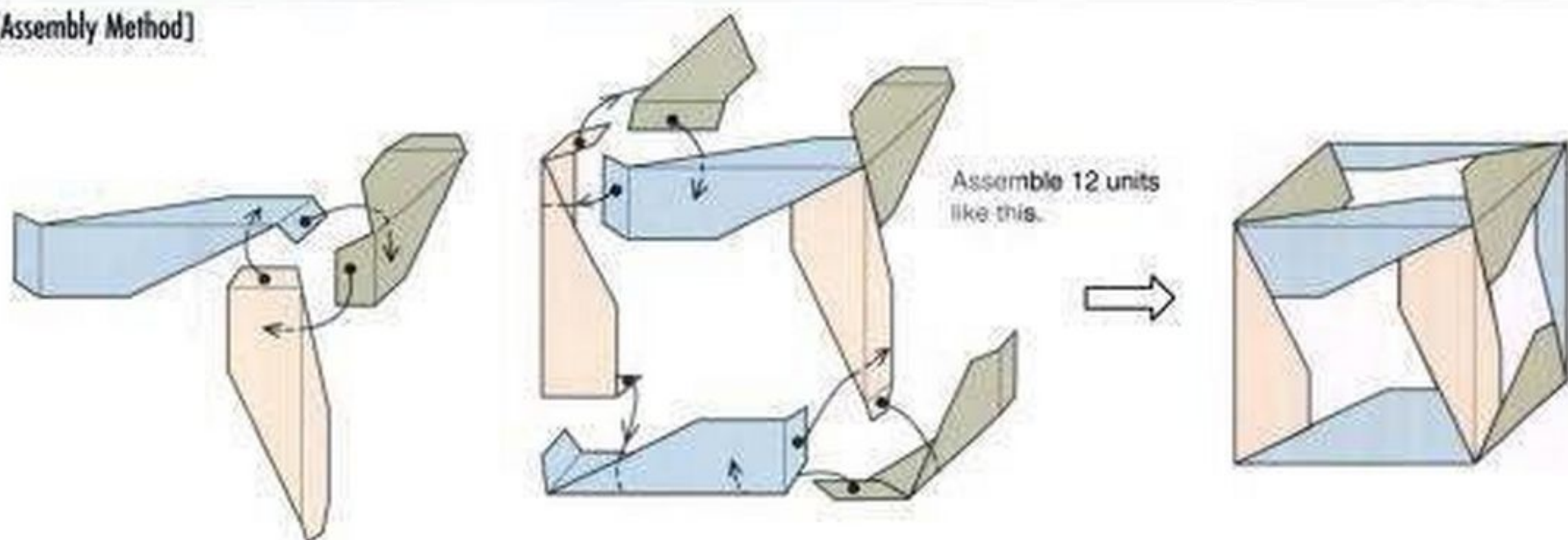



From step 4 on p. 48

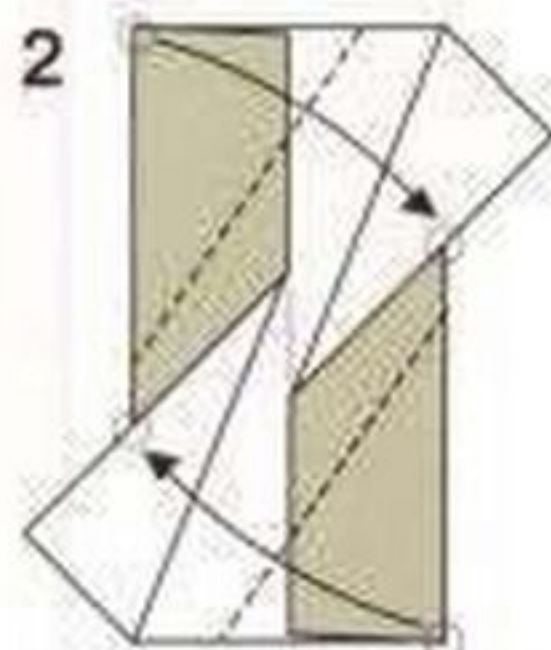

Fold so as to join the two circles ○.

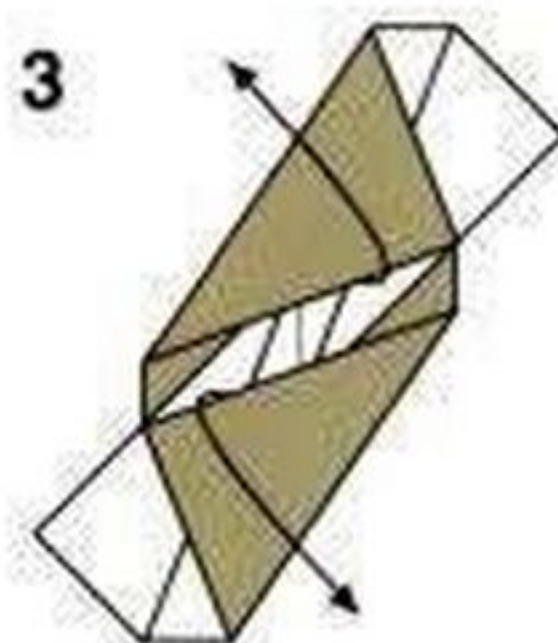

Unfold.

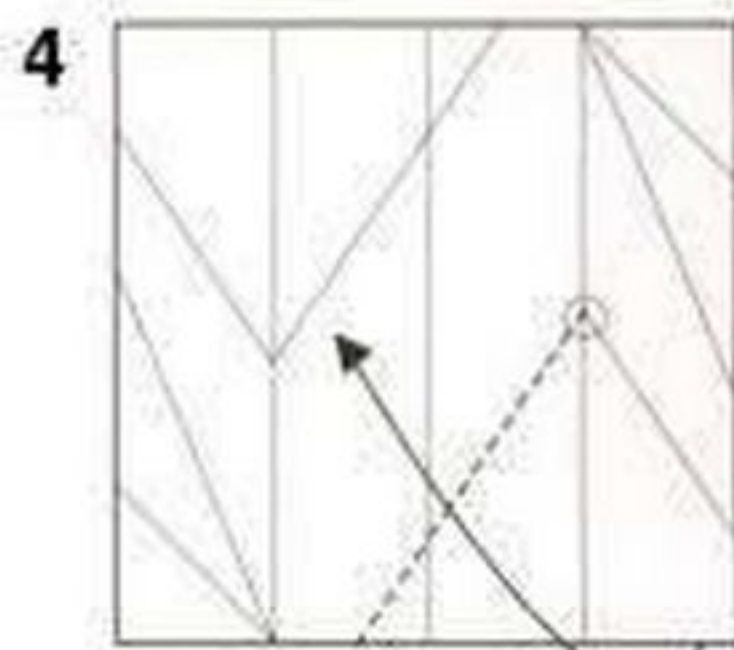

Fold to the place indicated by the circle ○.

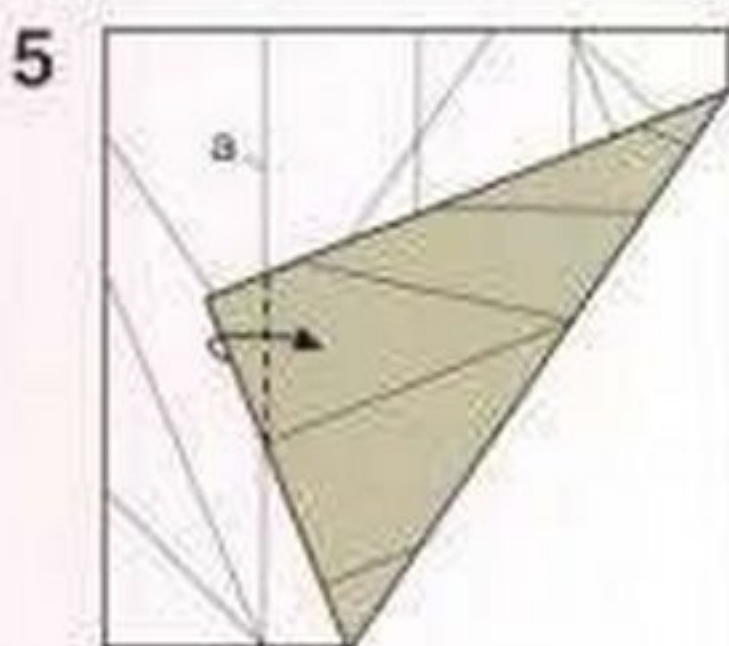

Fold on line (a).

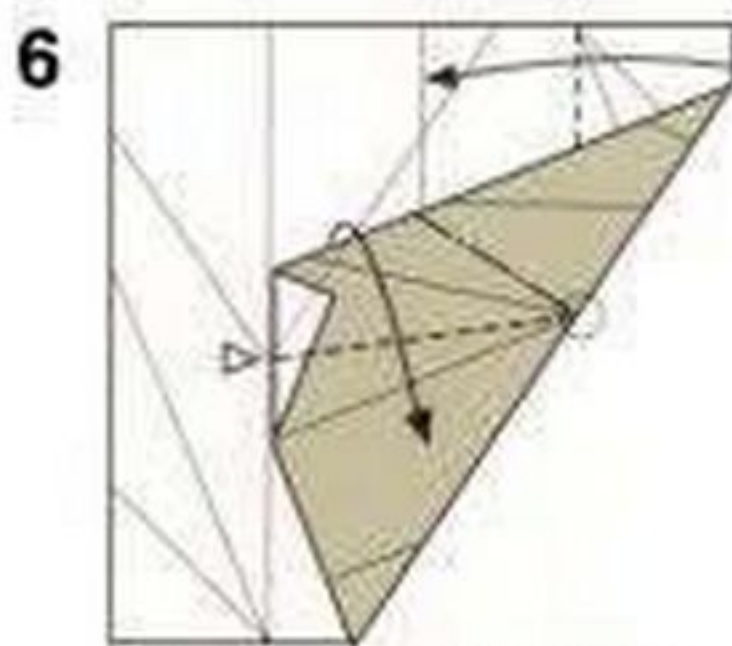

Fold on line between the triangle Δ and the circle ○.

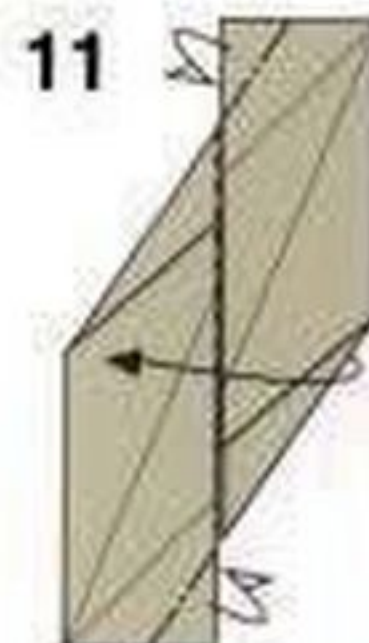
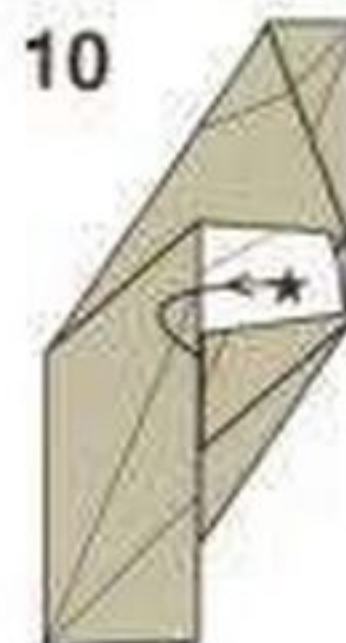
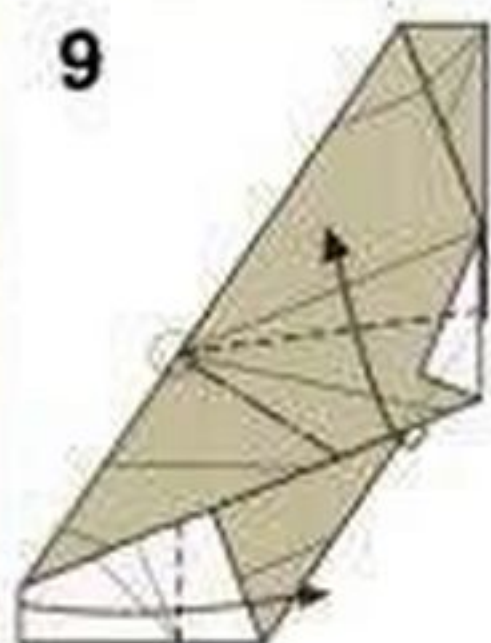
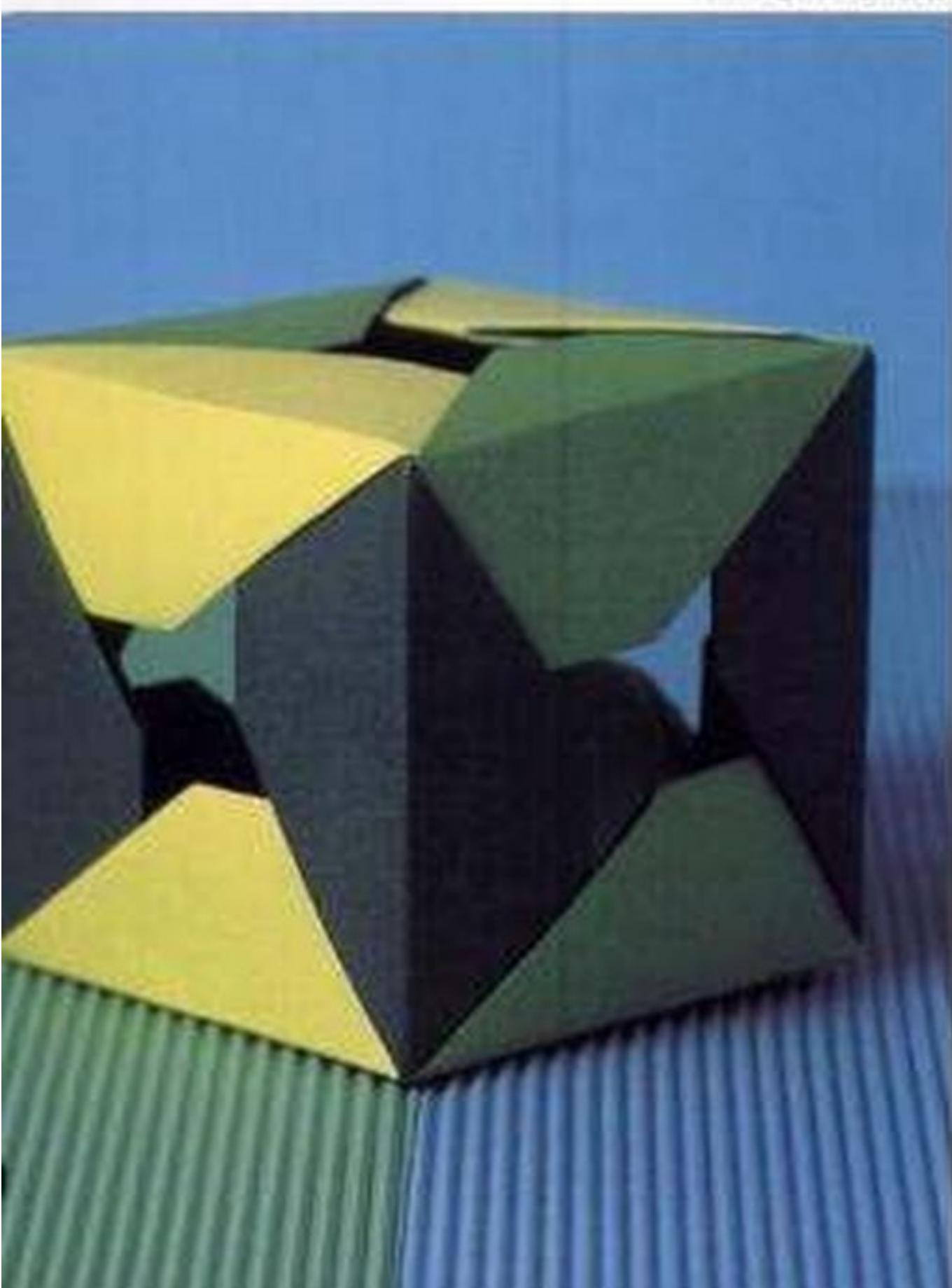
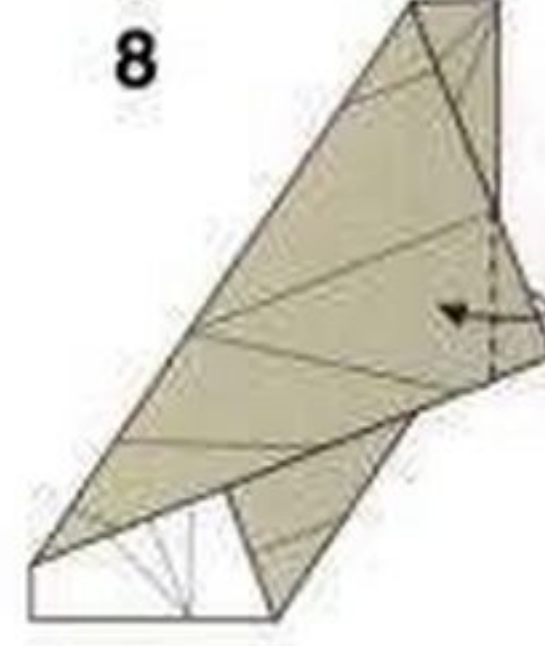
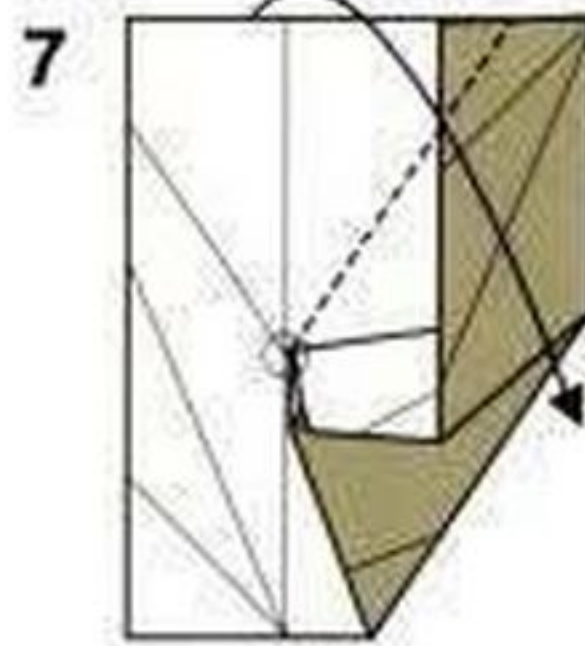

Tuck the tab marked with a star ★ inside the folds.

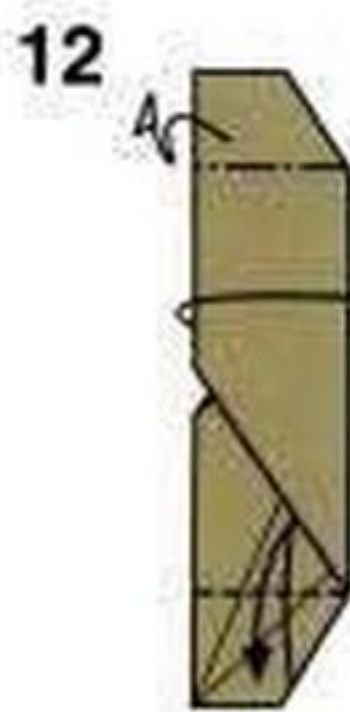

Make creases and unfold.

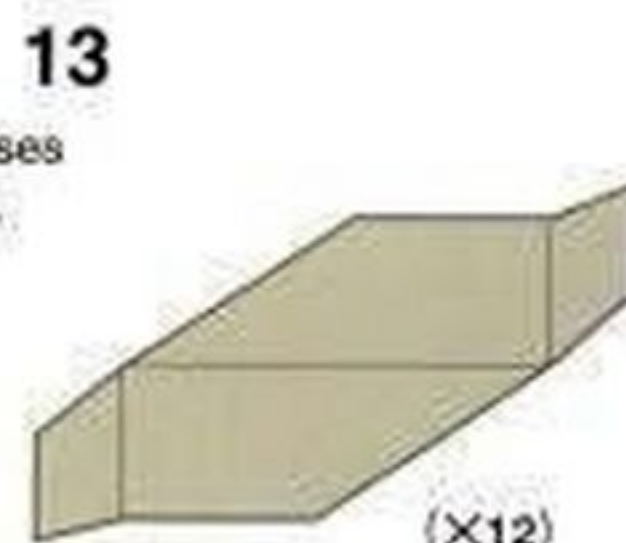

Assemble in the same way as the large cube (p. 49)



Starting from step 3 on p. 48.

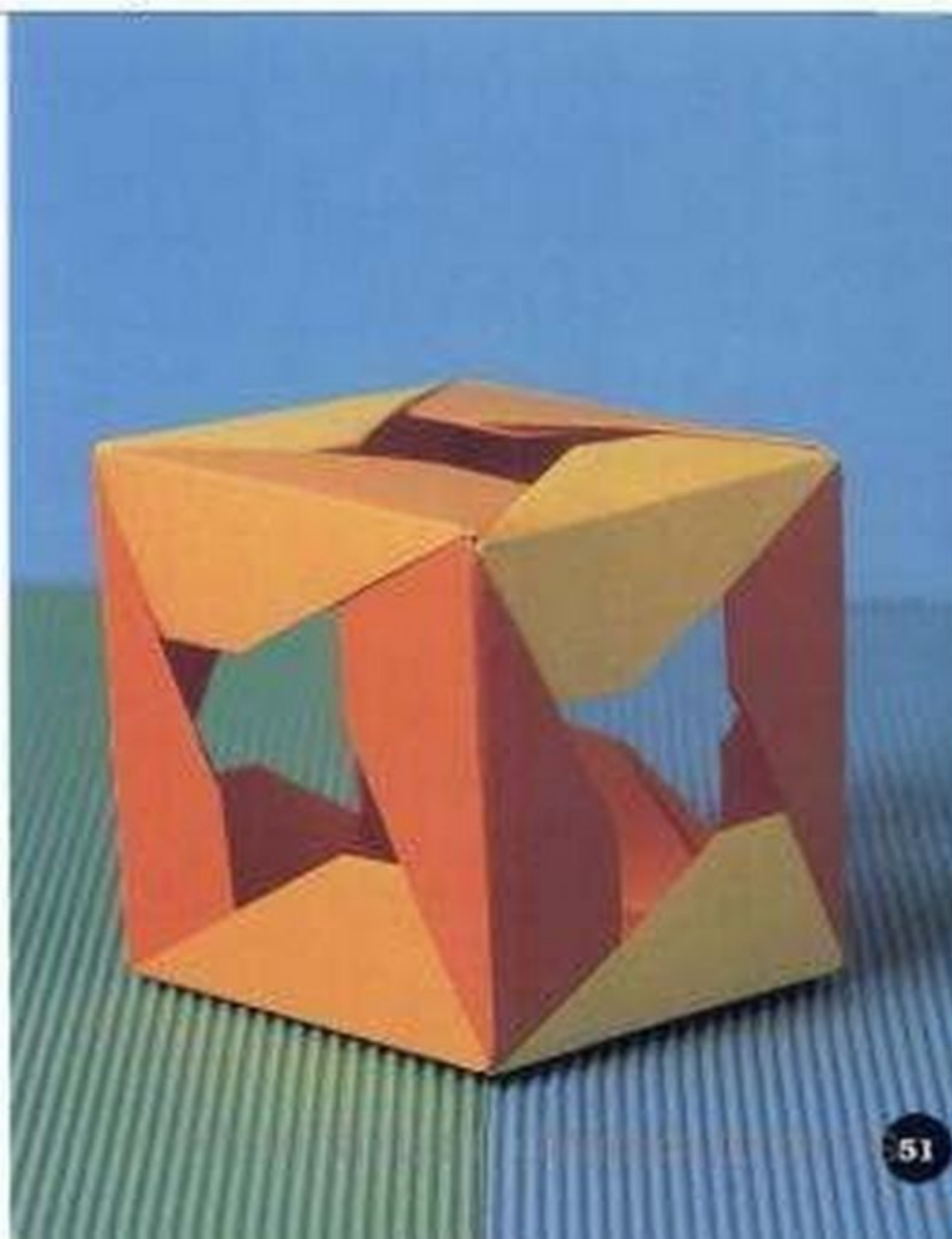
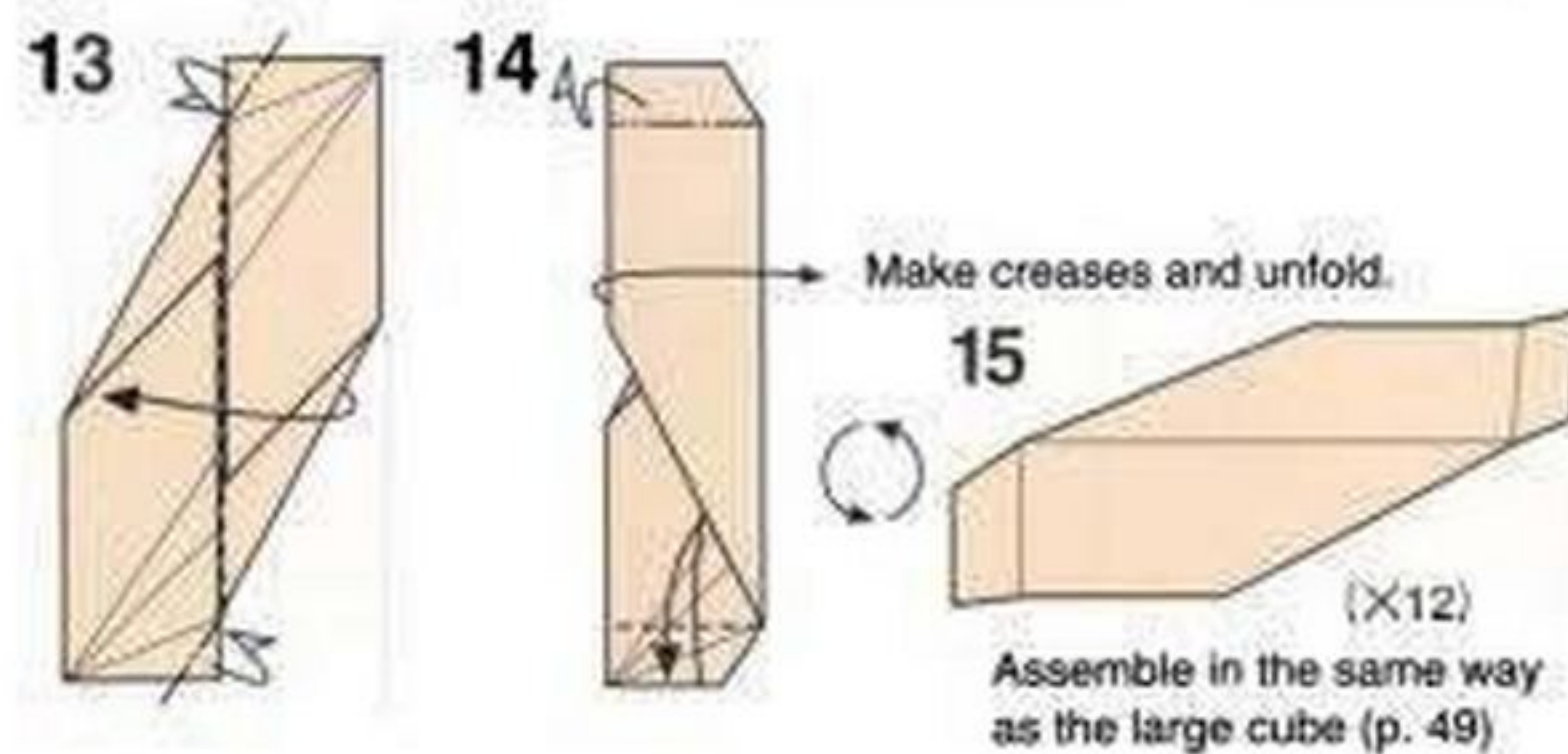
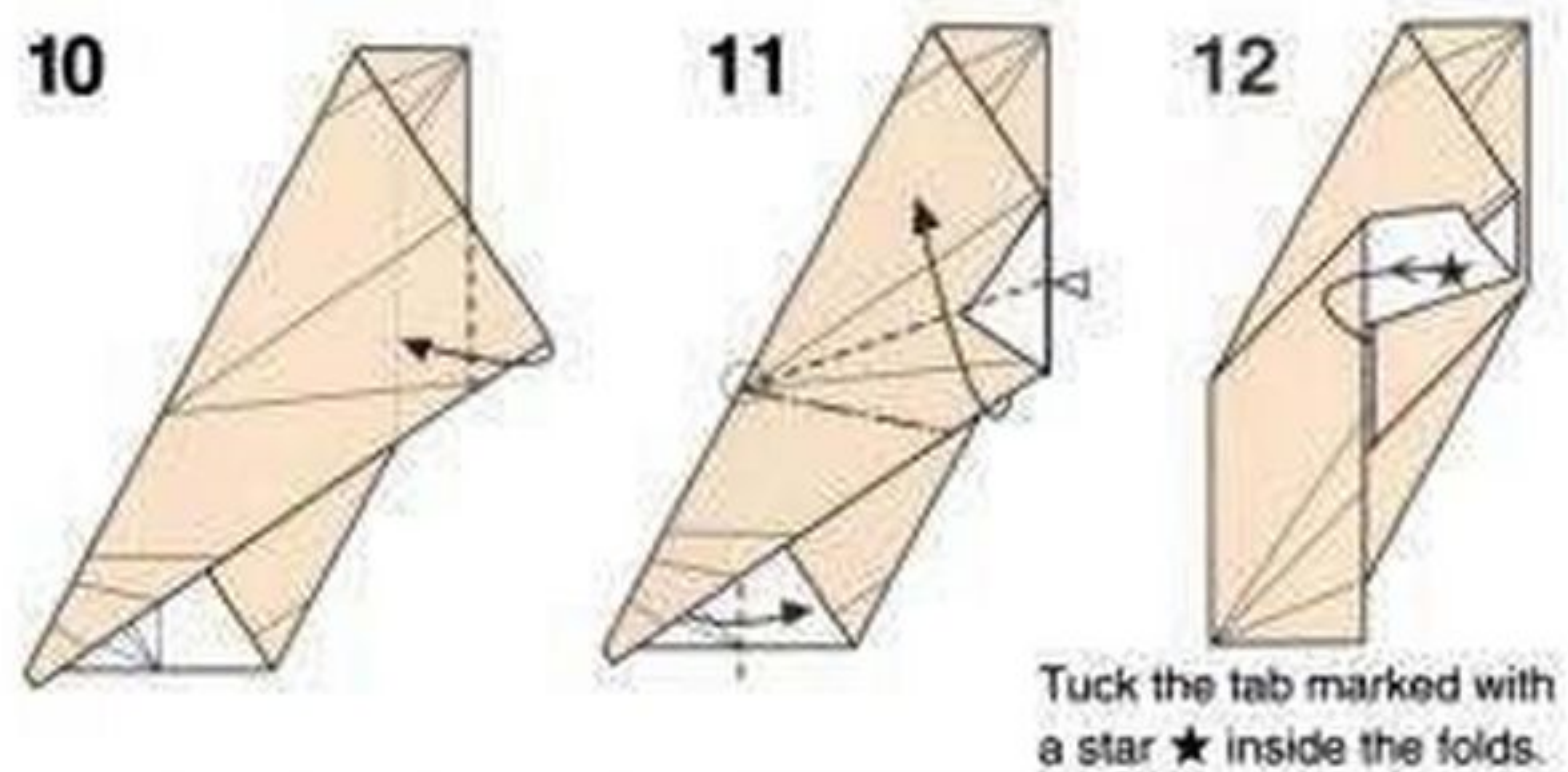
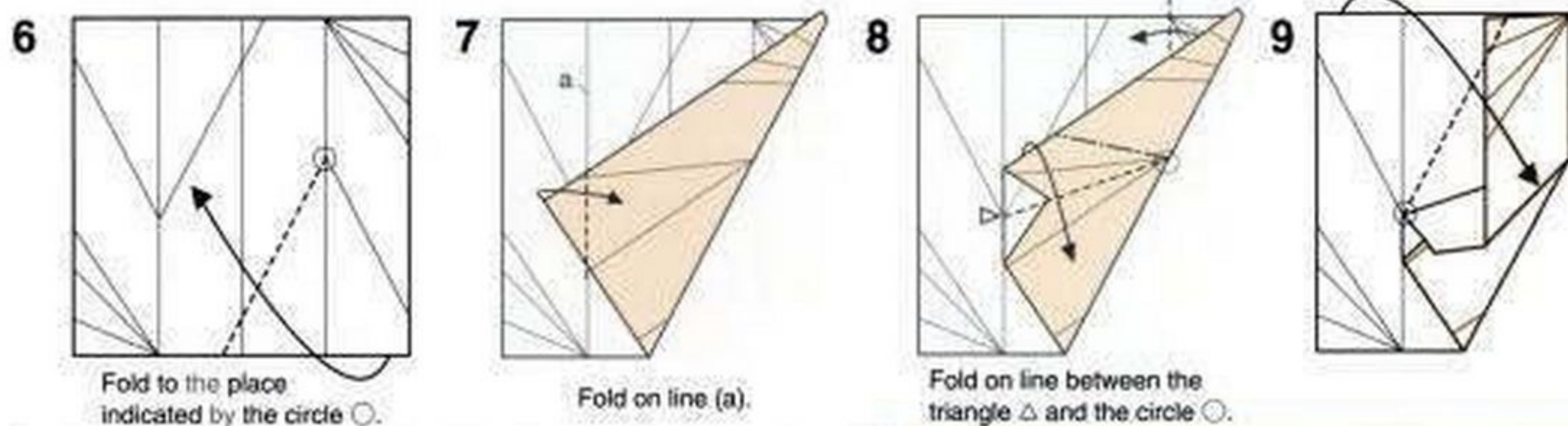
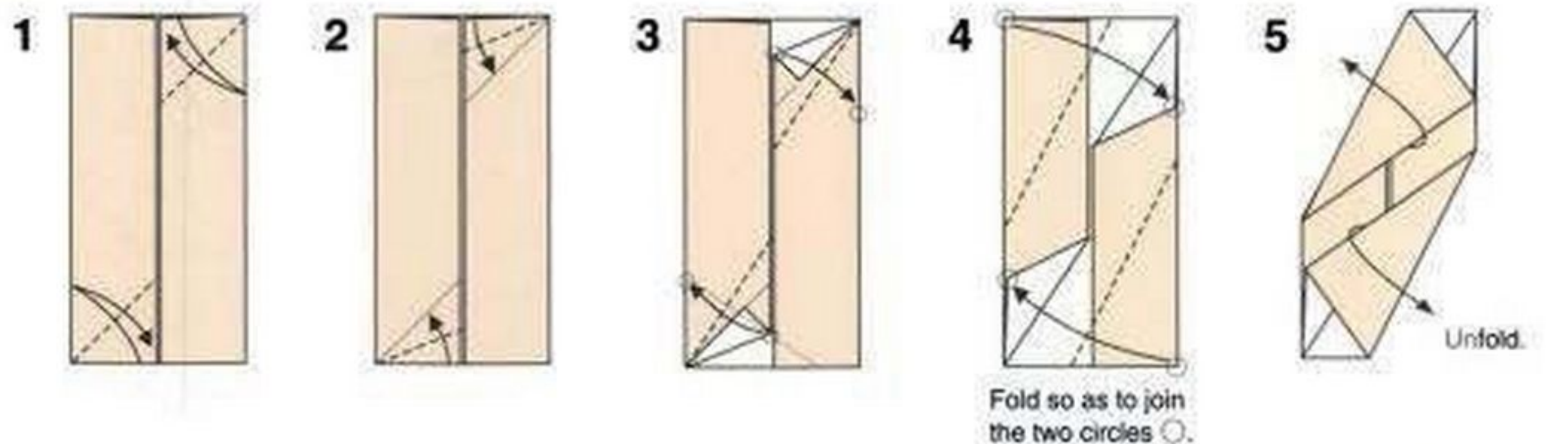



**120-UNIT STRUCTURE** /p.65

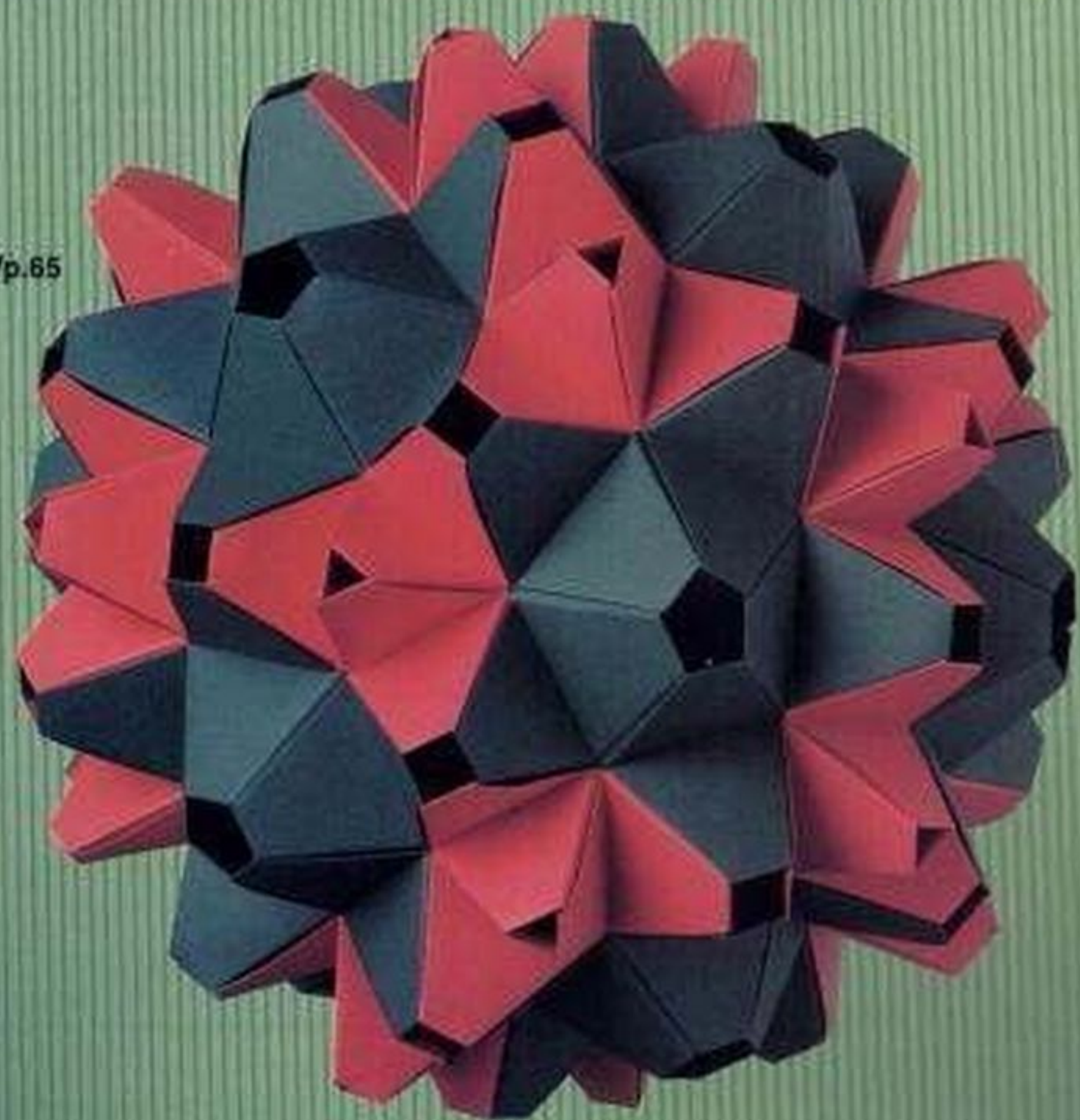

**12-UNIT STRUCTURE** /p.60



**30-UNIT STRUCTURE** /p.59

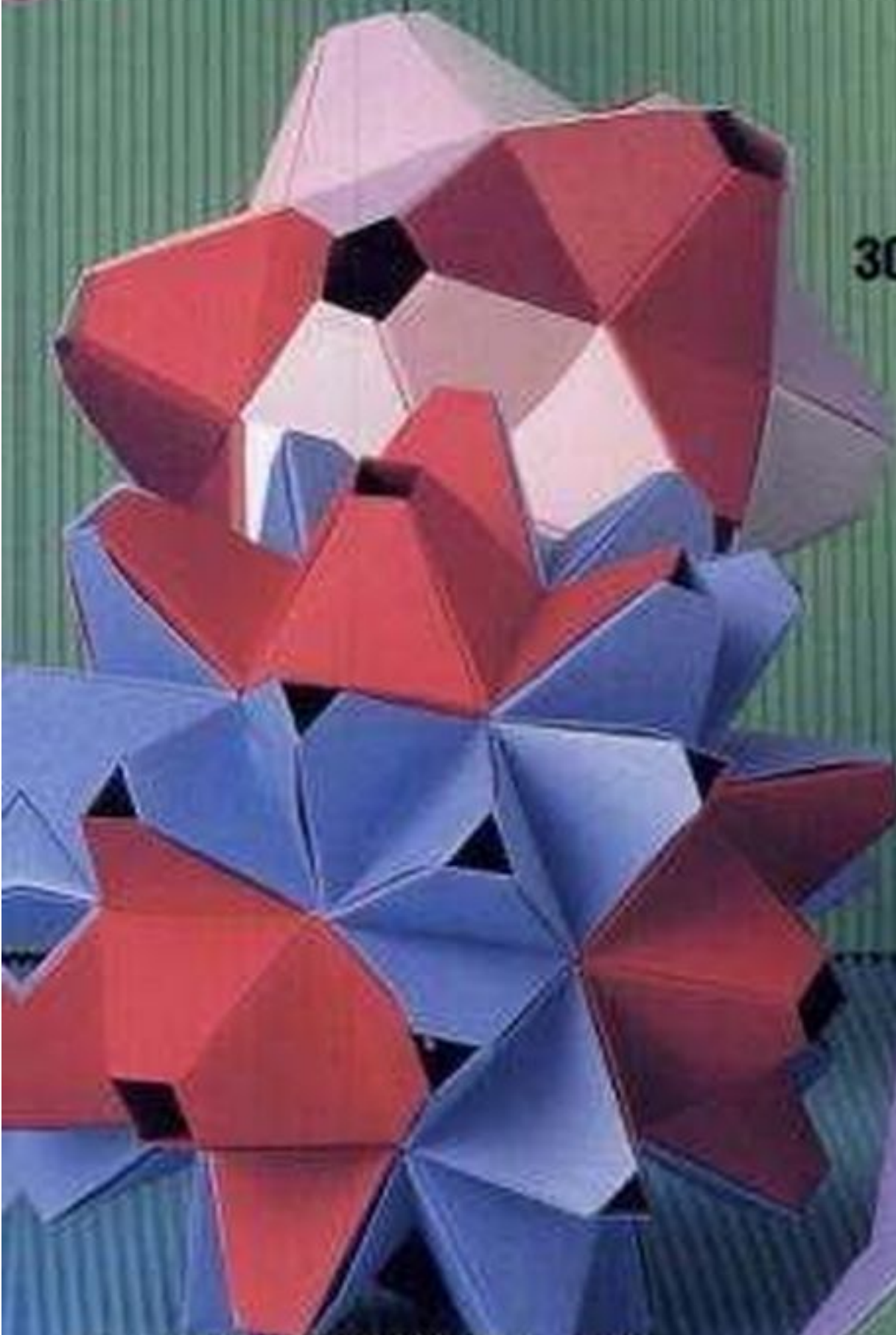

**24-UNIT STRUCTURE** /p.60

**30-UNIT STRUCTURE** /p.57

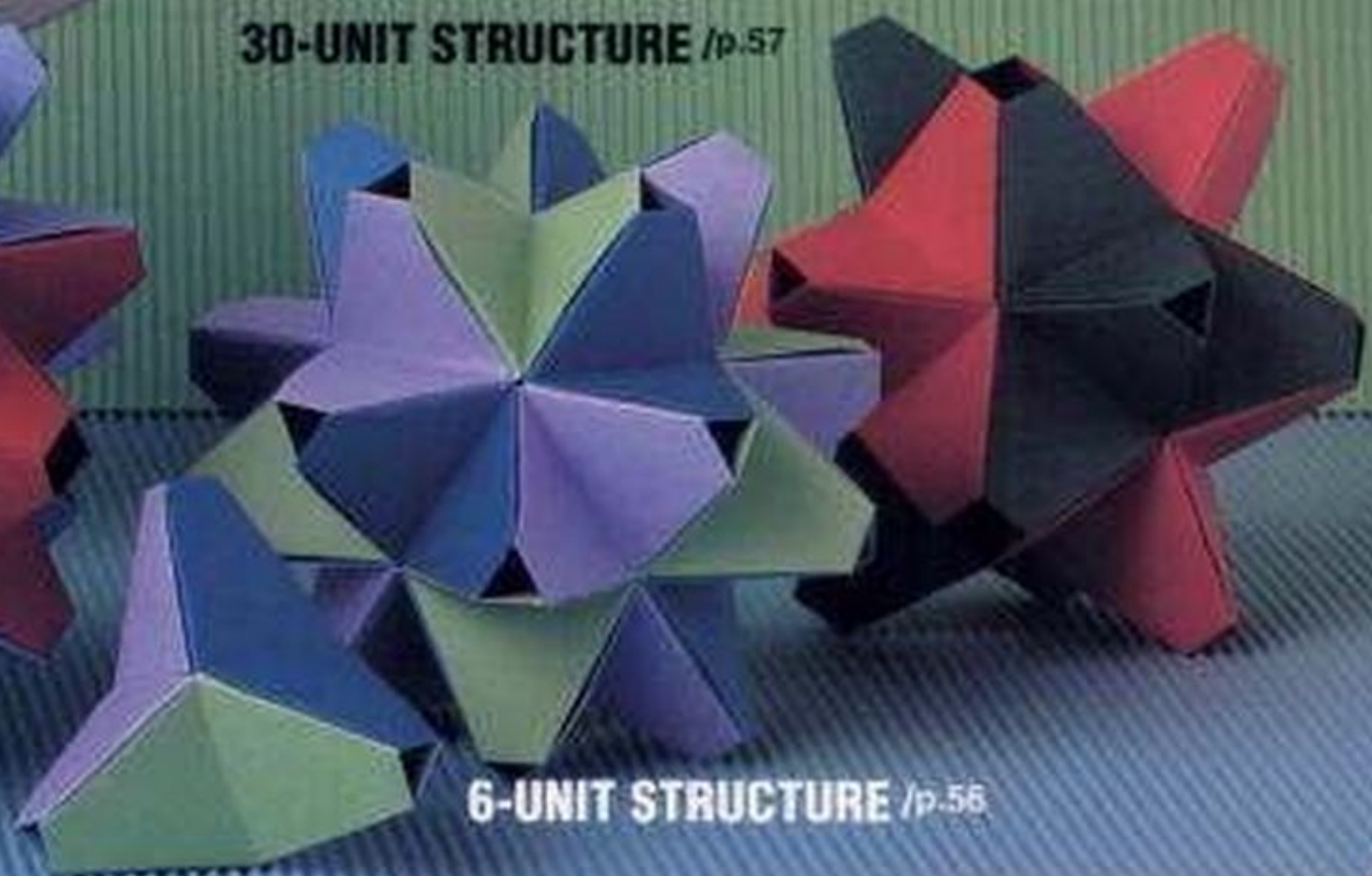

**60-UNIT STRUCTURE** /p.64

**6-UNIT STRUCTURE** /p.56



## HINT ON ASSEMBLY 2

Regular Tetrahedron

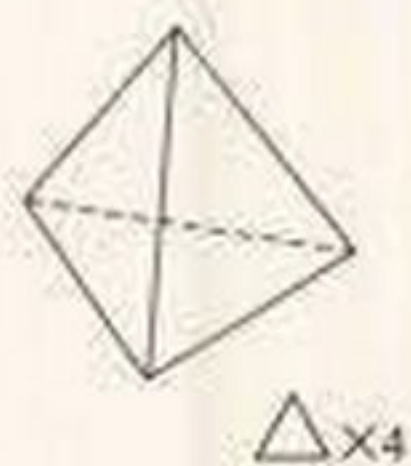

Cube

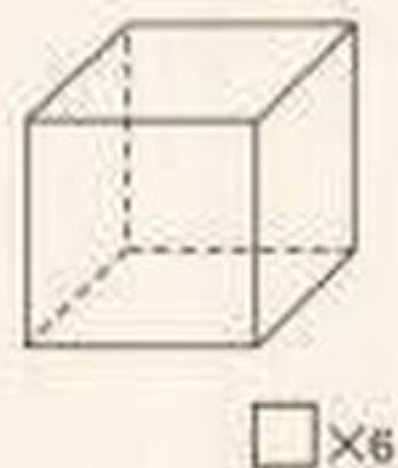

Cuboctahedron

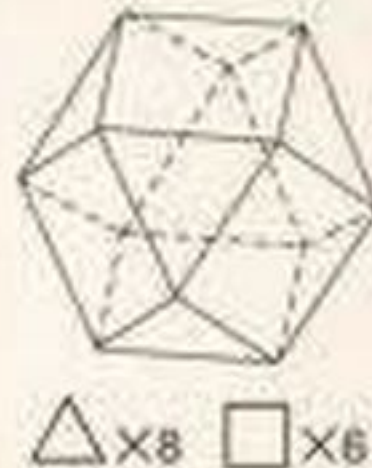

The bottom of each pyramidal unit has a different shape as shown below. You can use them to assemble various kinds of solids. Let's look at a regular tetrahedron, for example. The regular tetrahedron consists of 4 equilateral triangles. So you need to make a 3-unit structure, and put it together so that it has 4 triangular pyramids.

The next example is a cube consisting of 6 squares. So make a 4-unit structure, and put it together so that it has 6 square pyramids. When combining different shapes, begin with the smallest structure, although there may be cases in which you follow a different order. If you intend to make a cuboctahedron, begin with a 3-unit structure. Make it the core, and enlarge it by connecting the units one by one.

Assemble the 5-unit structure and the 6-unit structure in the same way.

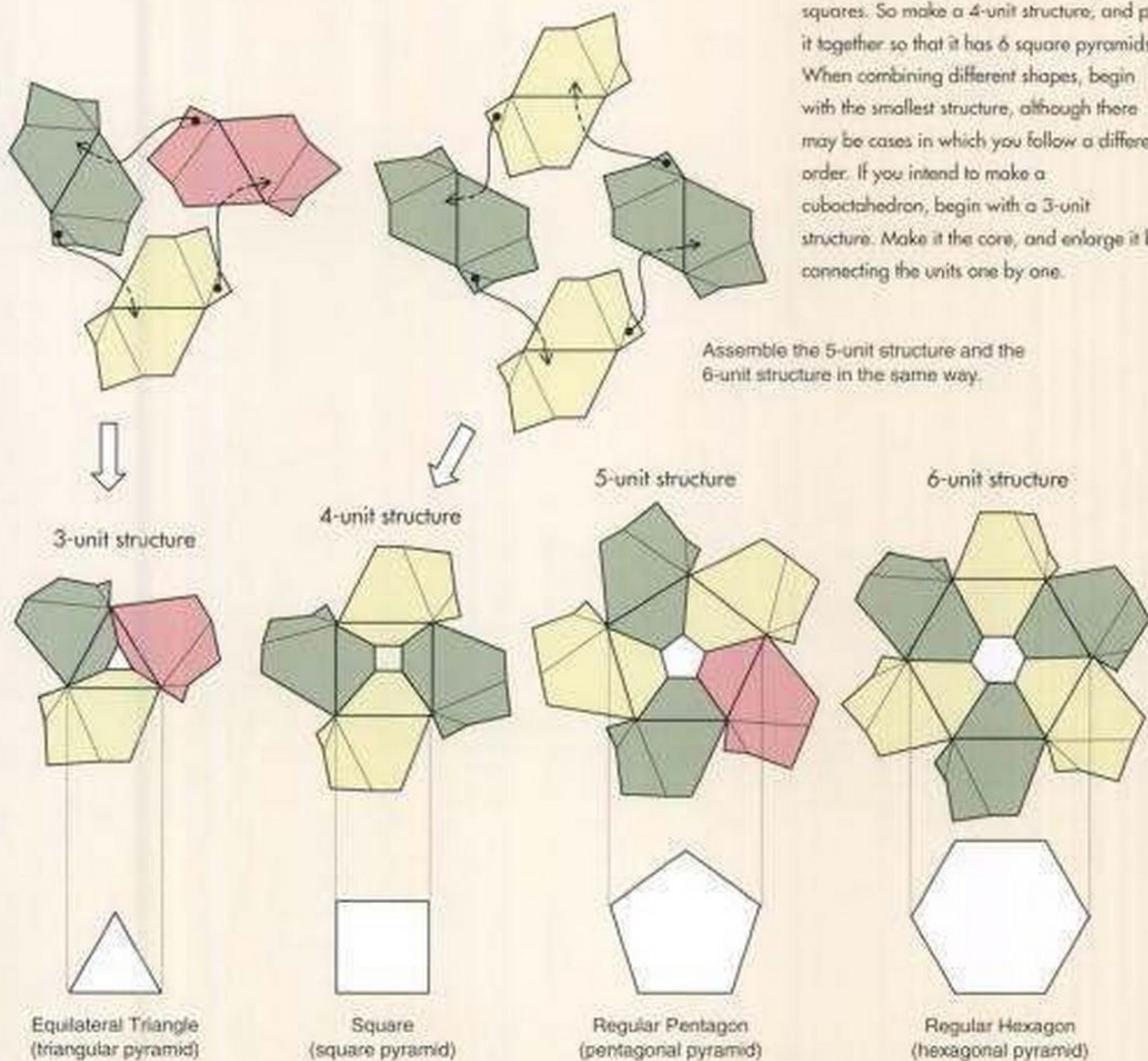



Double-sided convex hexagonal ring (p. 54)

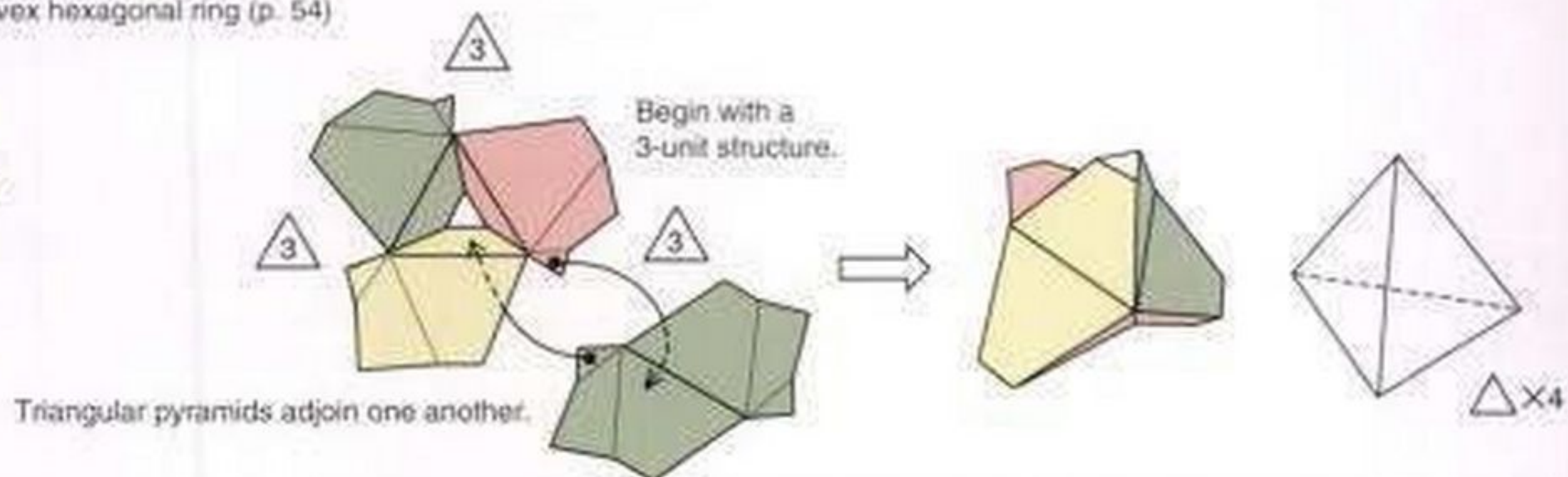
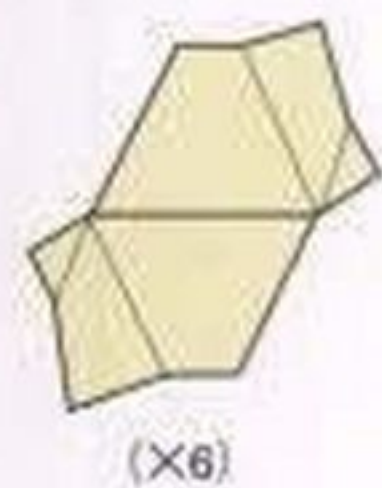

Double-sided convex hexagonal ring (p. 54)

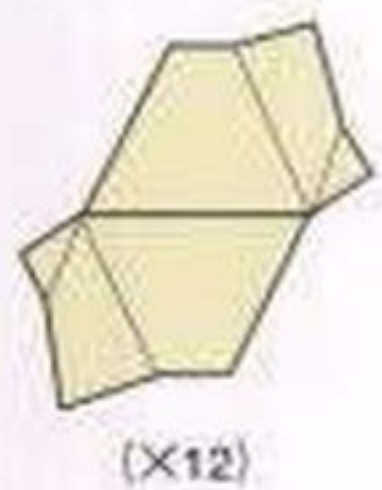

Triangular pyramids adjoin one another.

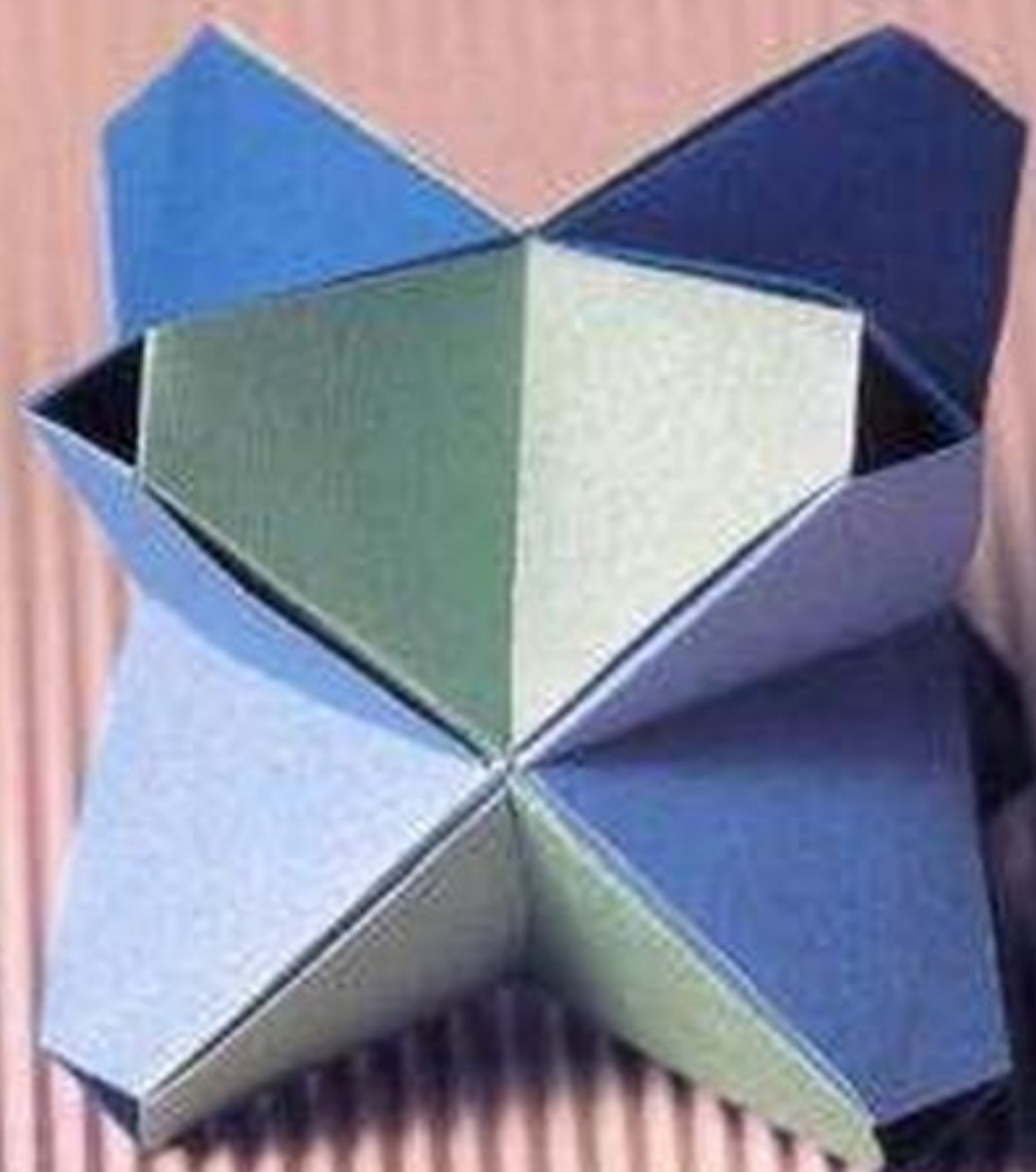
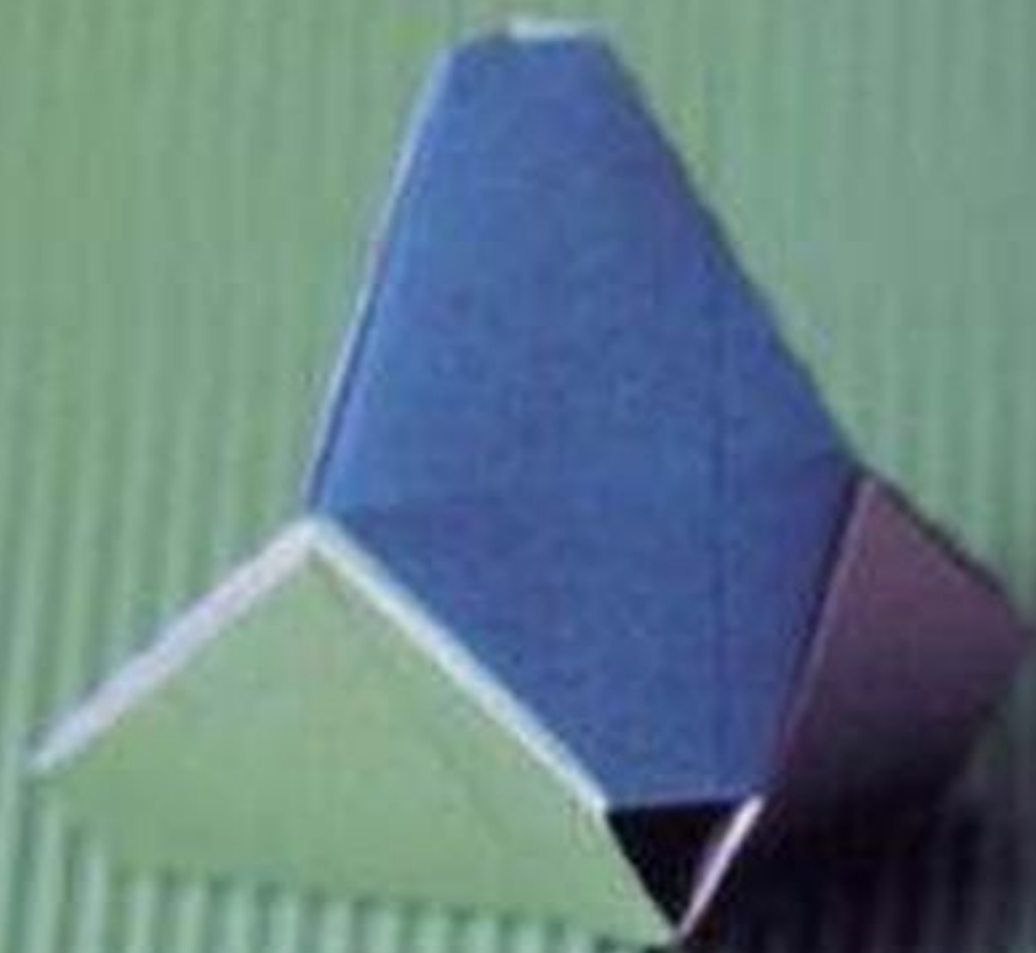
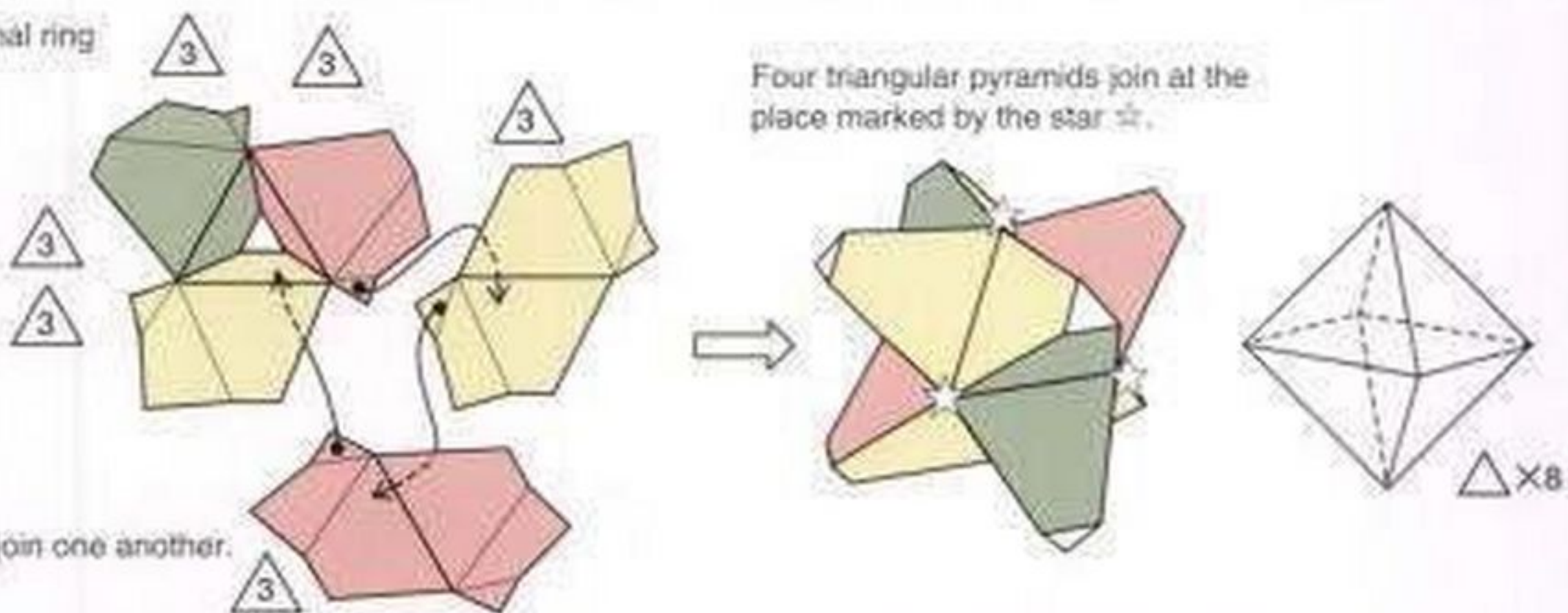



Double-sided convex hexagonal ring (p. 54)

Five triangular pyramids join at the place marked with a star ☆.

Make 5 triangular pyramids centered around the place marked with a star ☆.

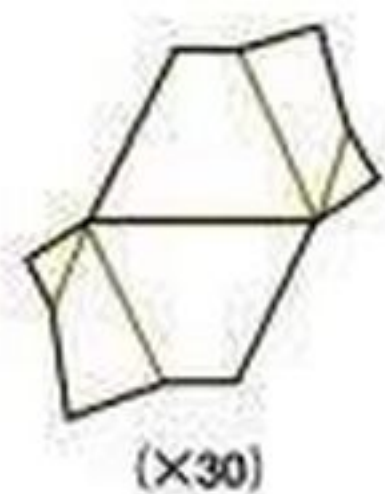

Begin with a 3-unit structure.

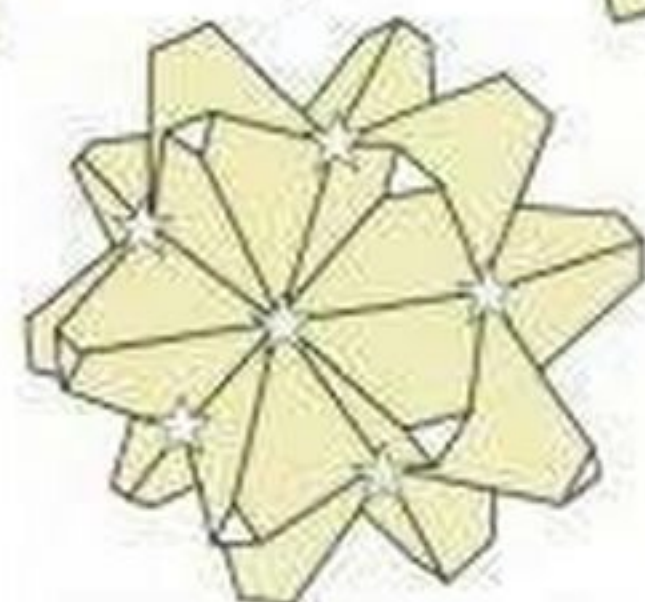
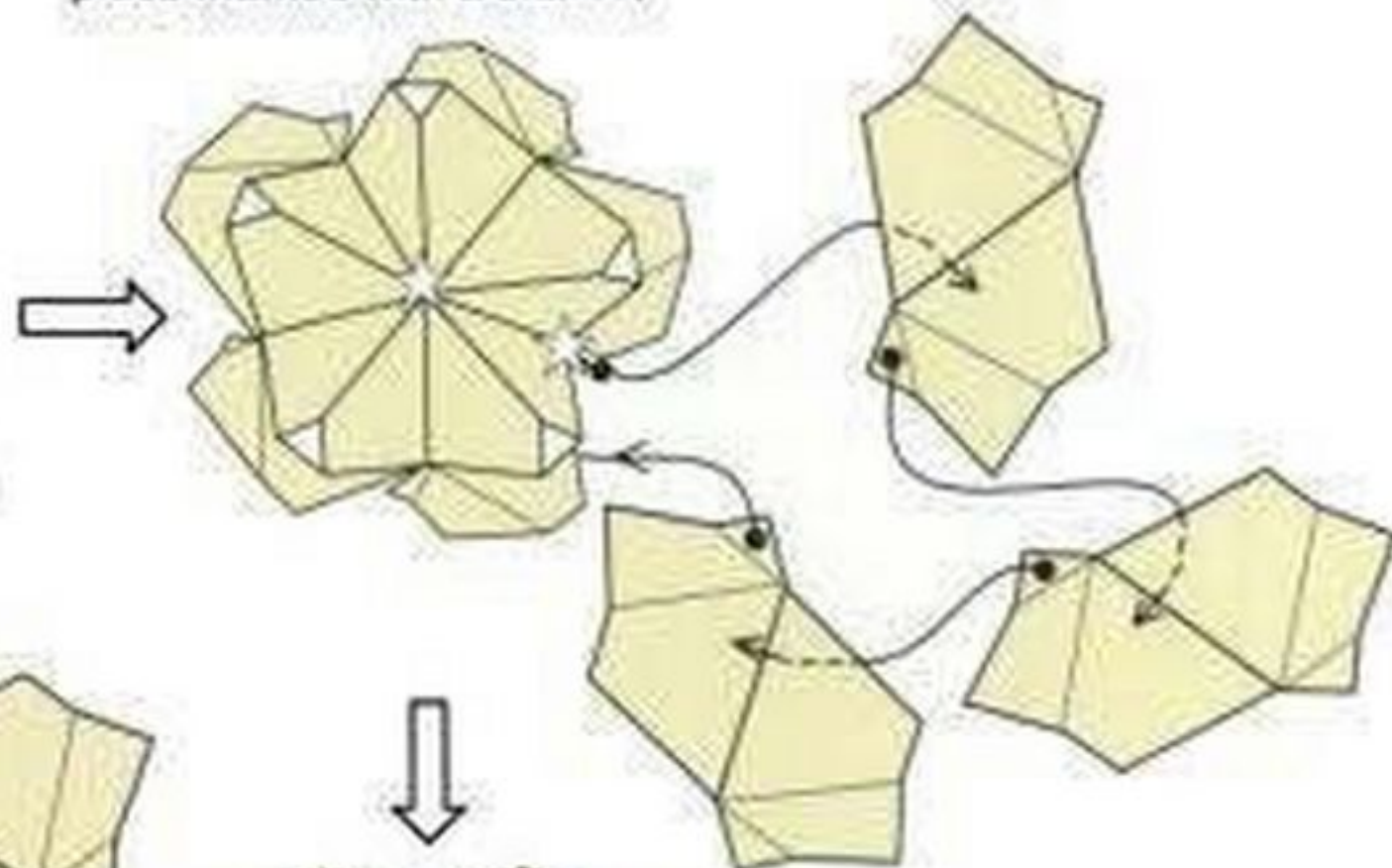
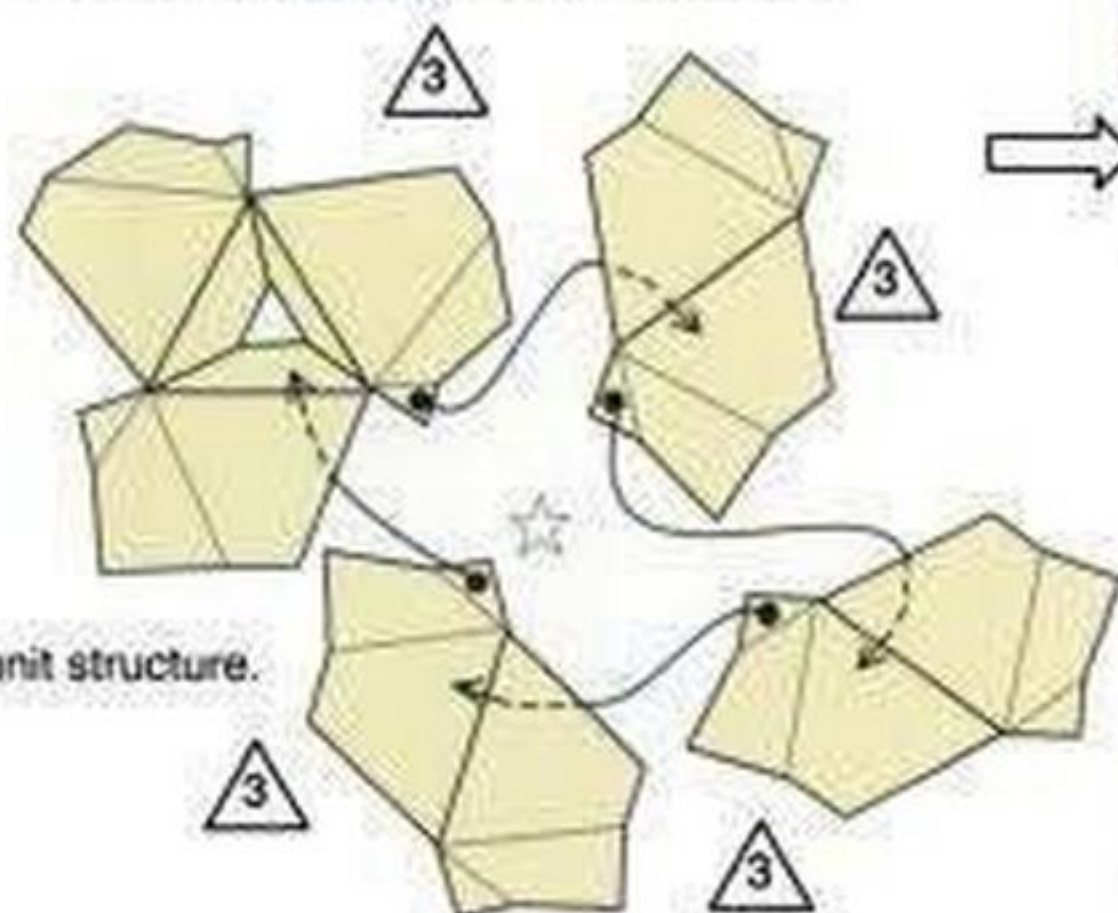

Five triangular pyramids join at the place marked with a star ☆.

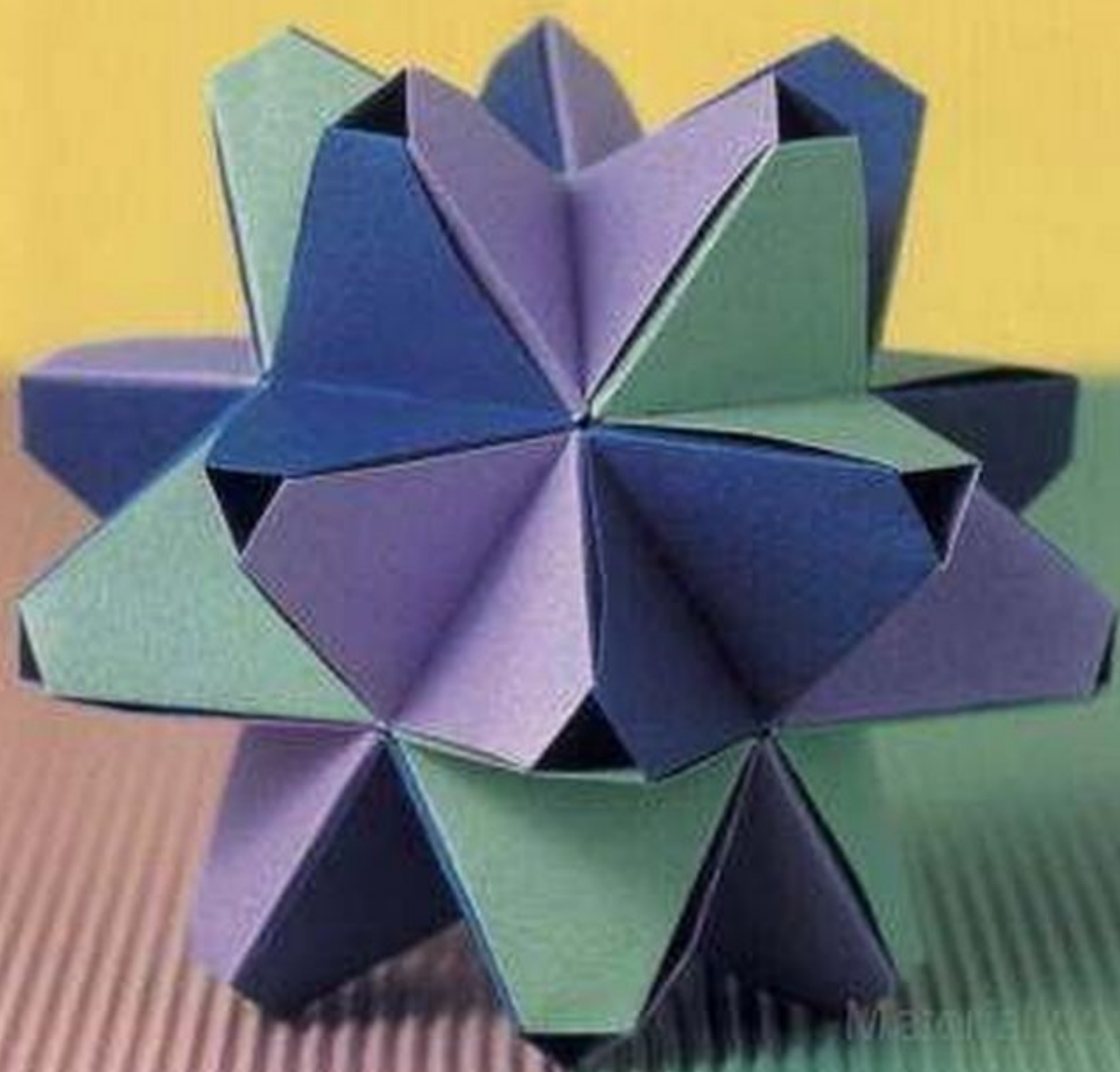



# 36-UNIT STRUCTURE Truncated Octahedron level ★★

12cm x 6cm

Double-sided convex hexagonal ring (p. 54)

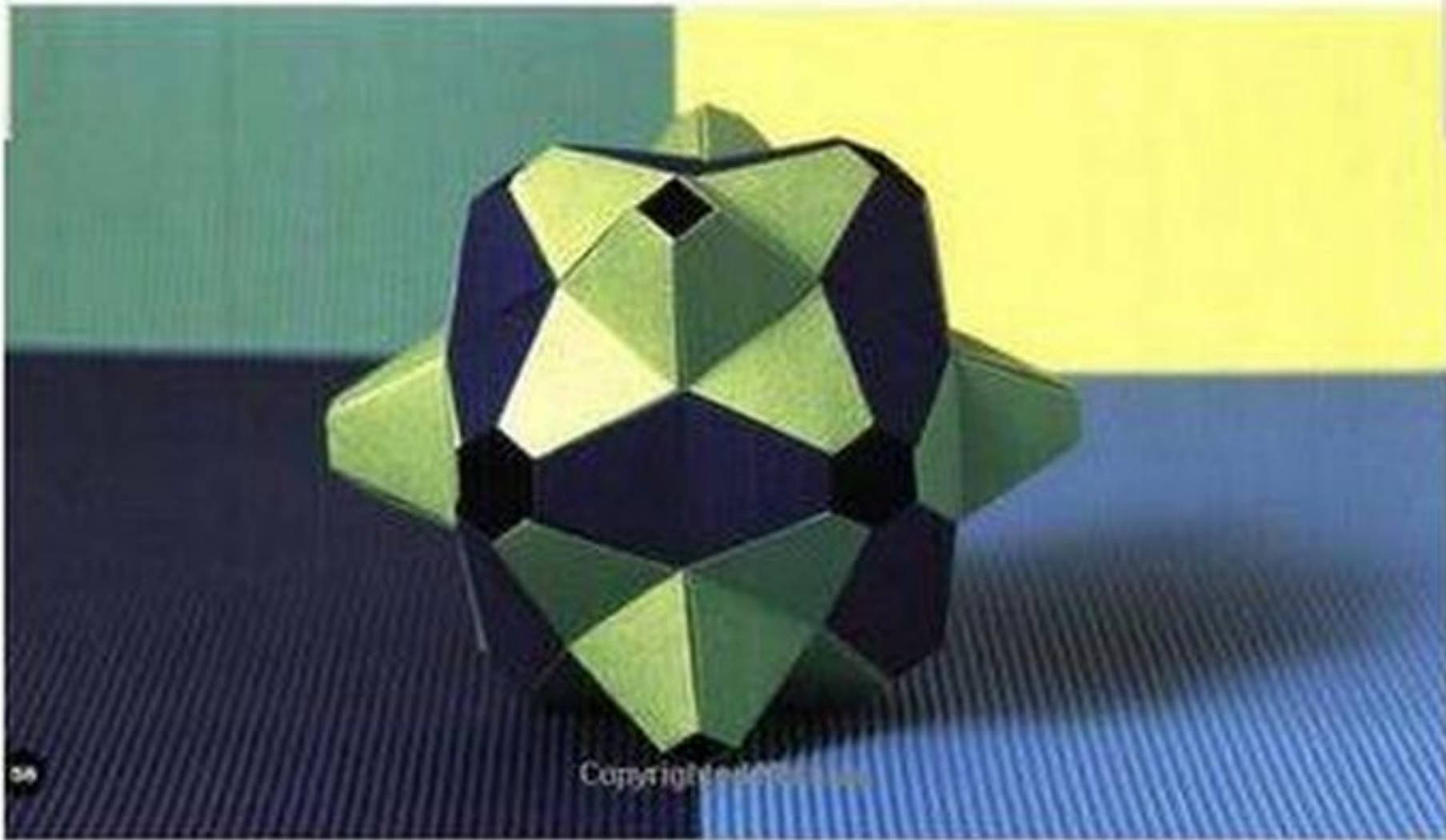
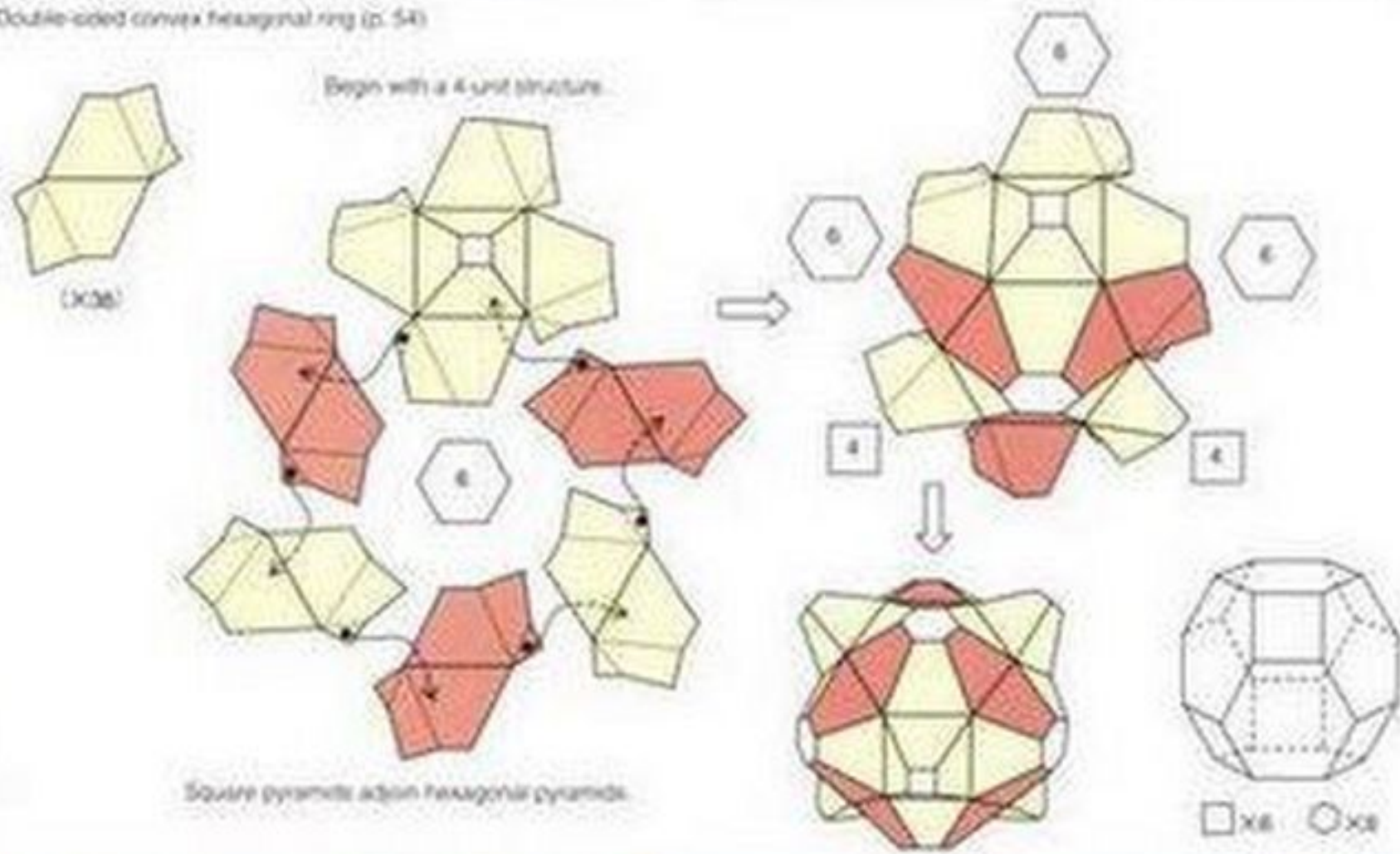



# 12-UNIT STRUCTURE Cube, 24-UNIT STRUCTURE Cuboctahedron

level ★

12cm × 6cm

Double-sided convex hexagonal ring (p. 54)

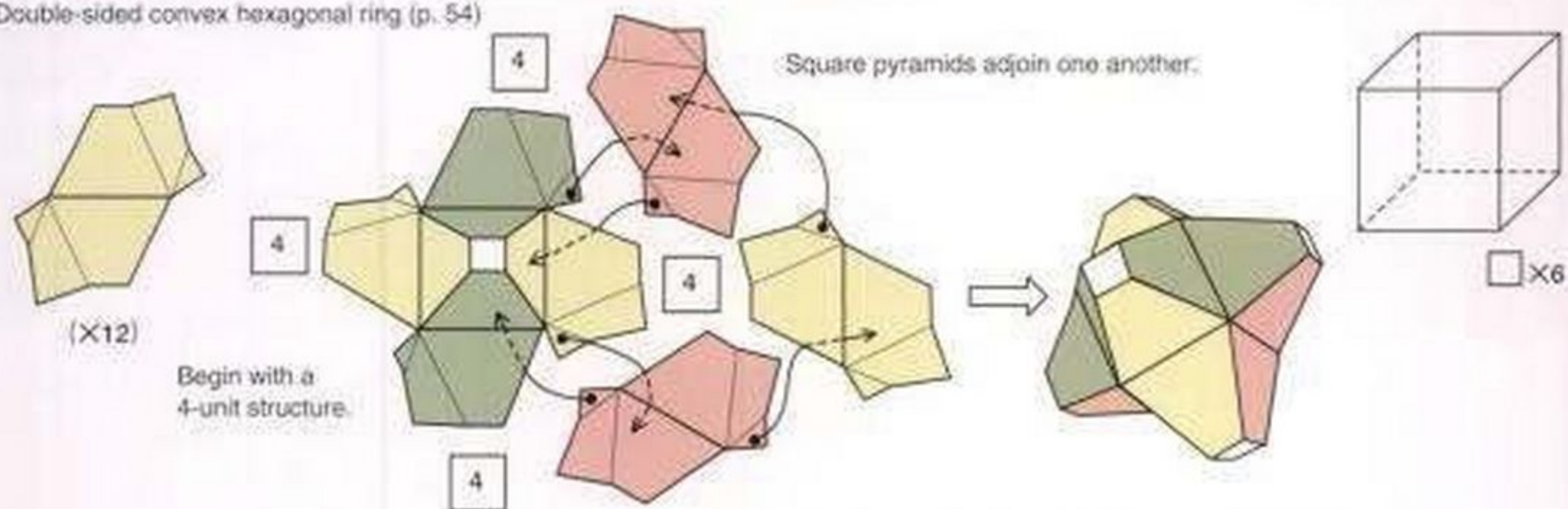

Double-sided convex hexagonal ring (p. 54)

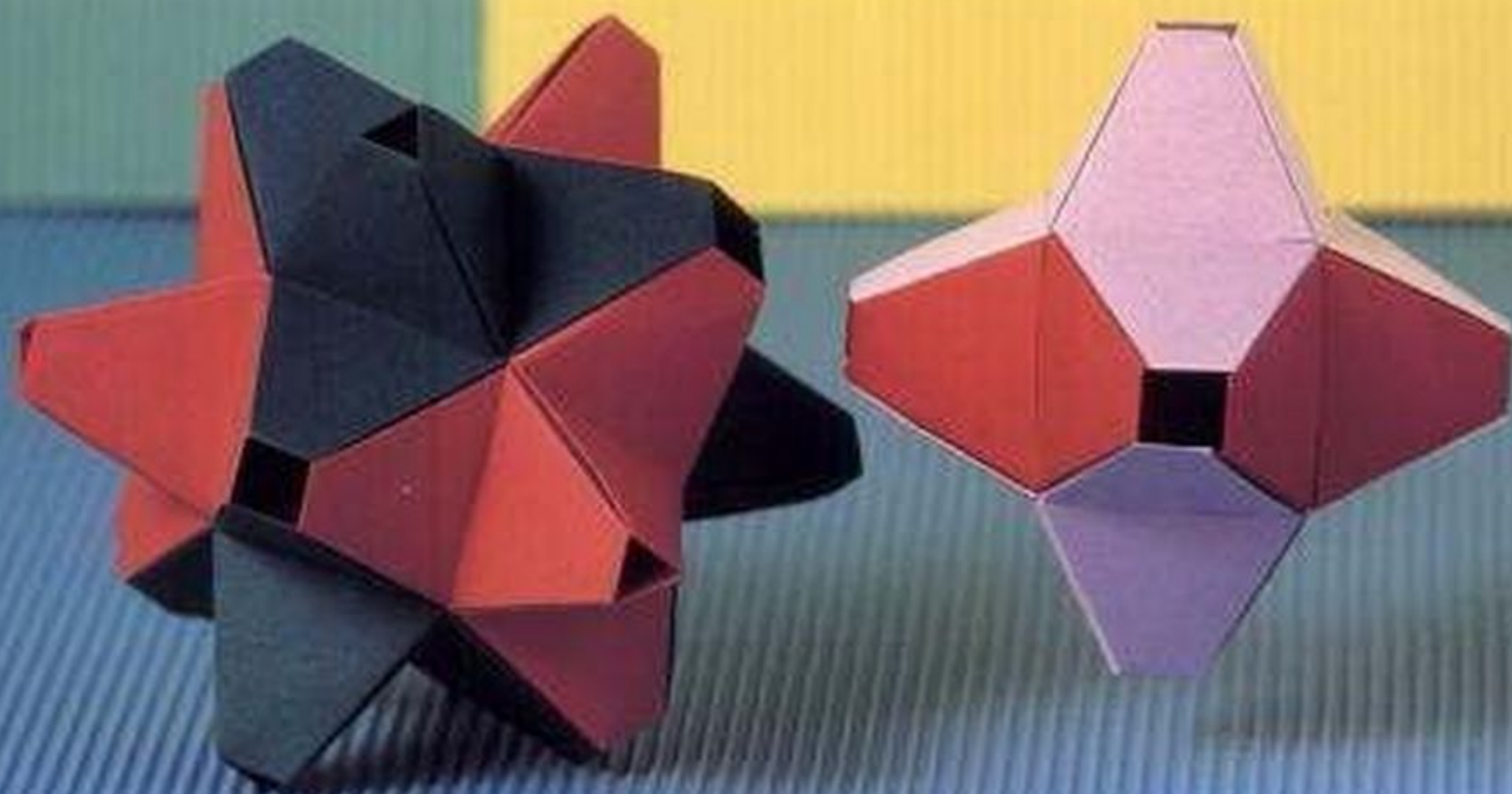
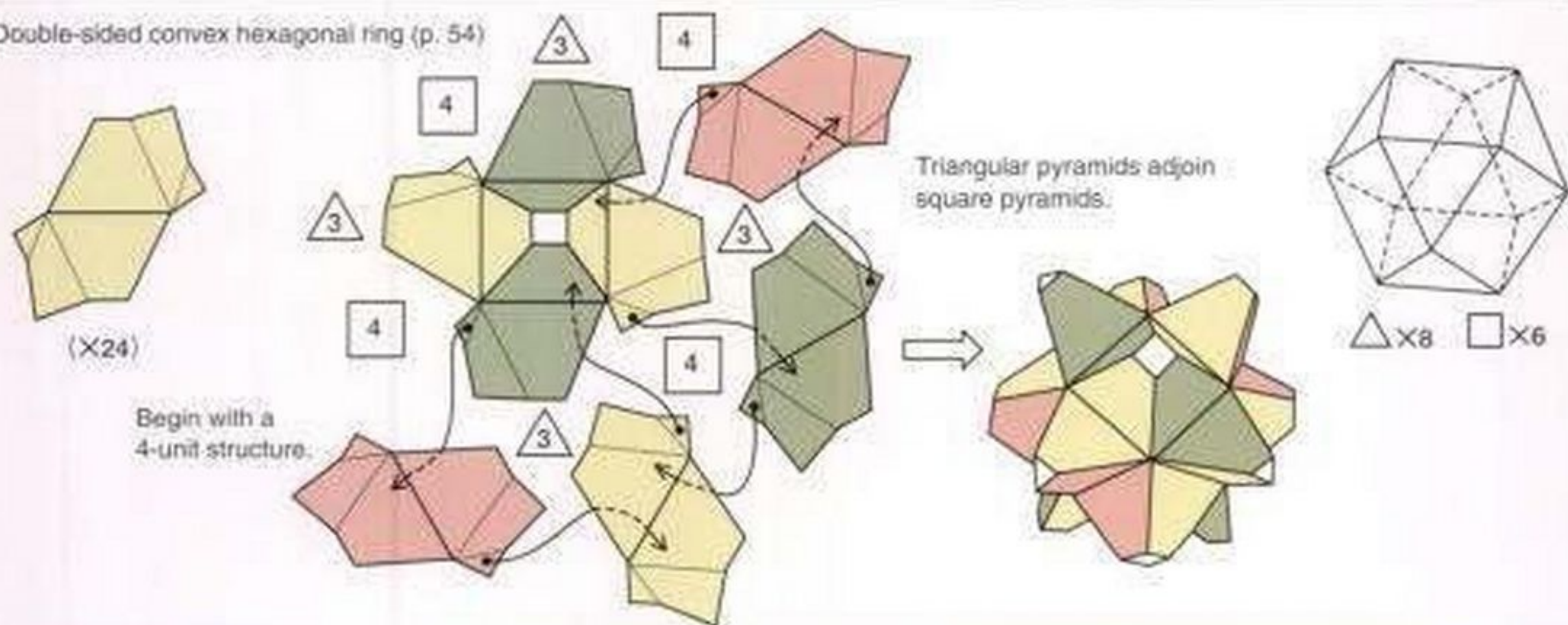



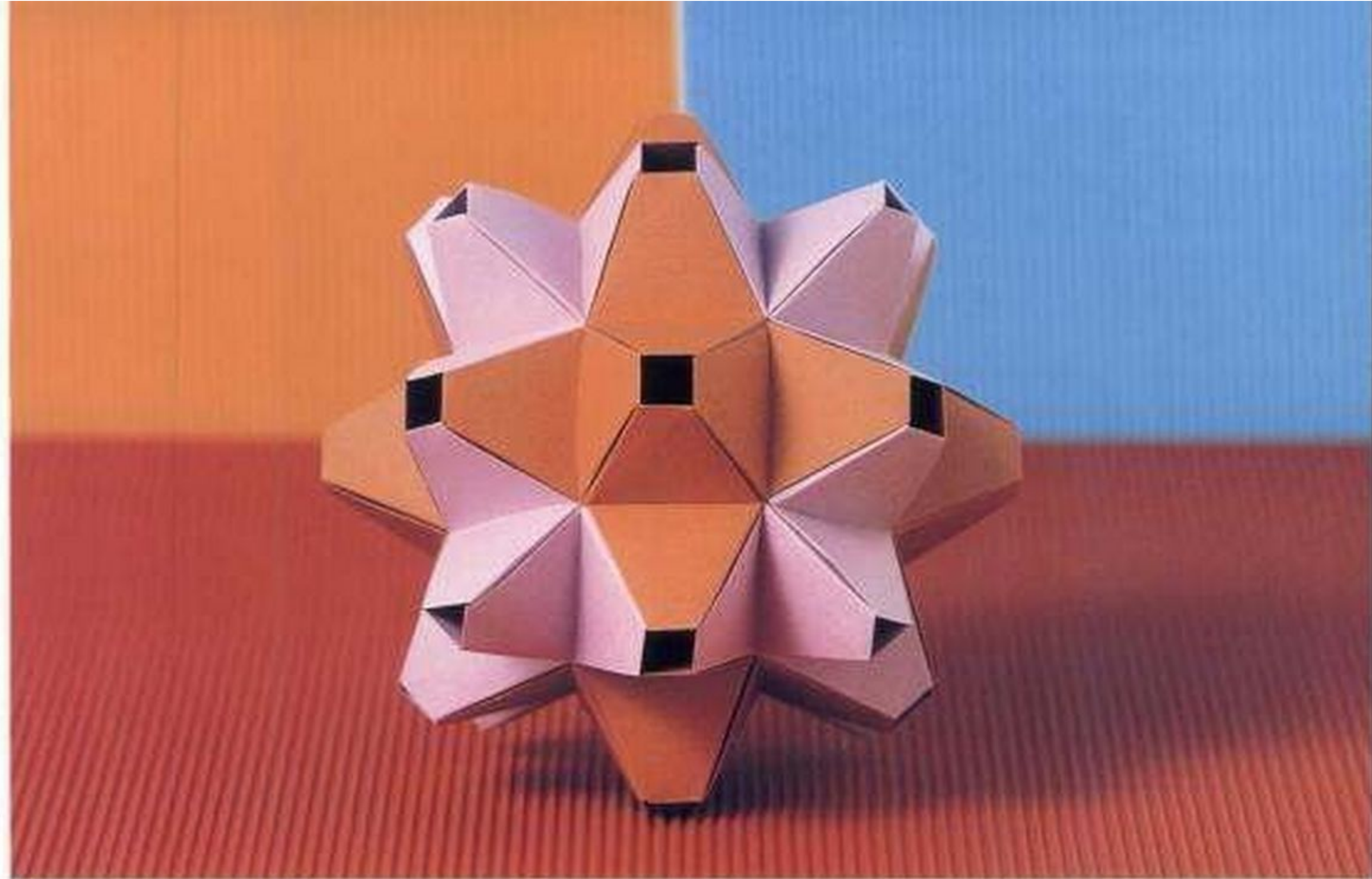

## 48-UNIT STRUCTURE Rhombic Cuboctahedron | level ★★

12cm × 6cm

Double-sided convex hexagonal ring (p. 54)

Begin with a 4-unit structure.

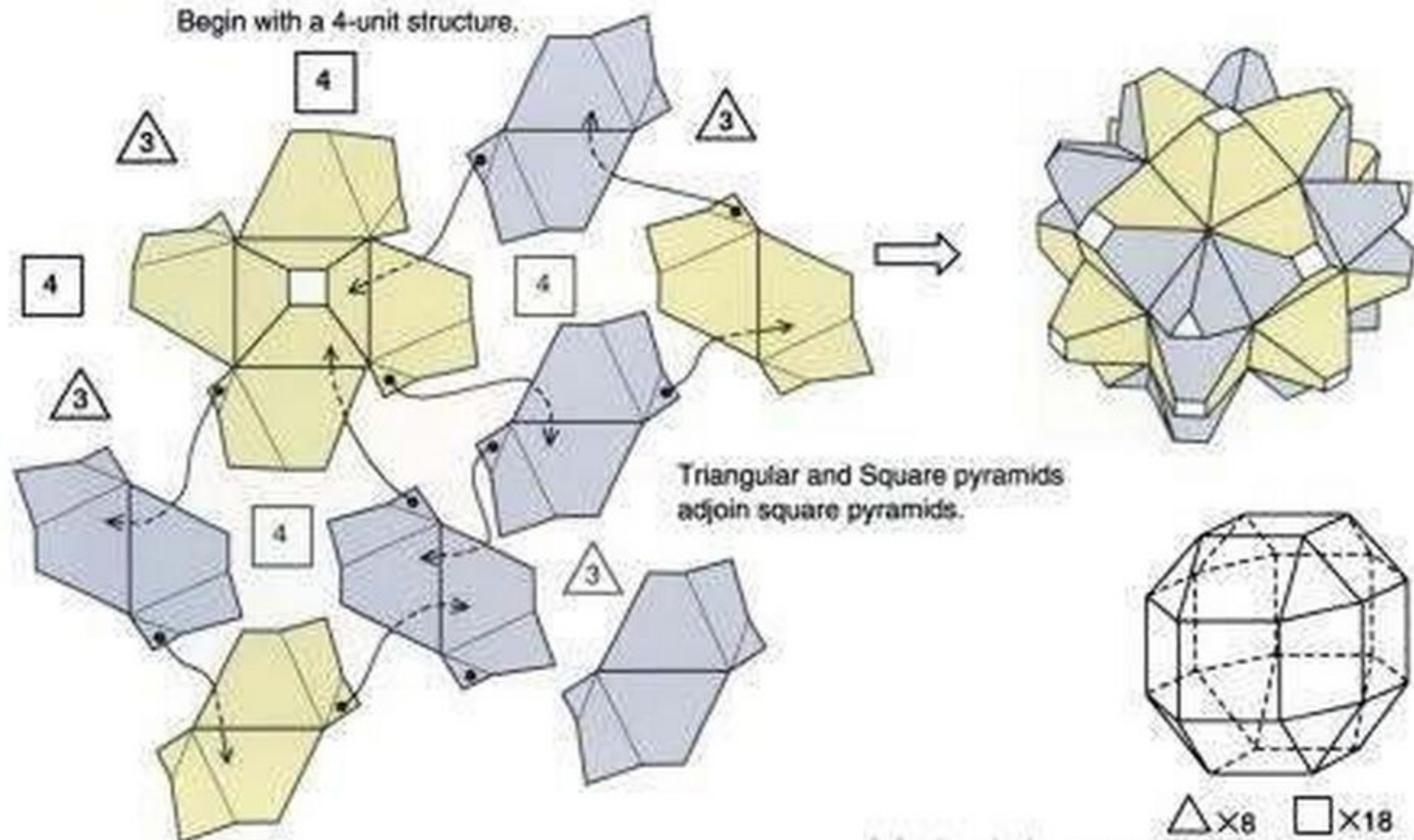
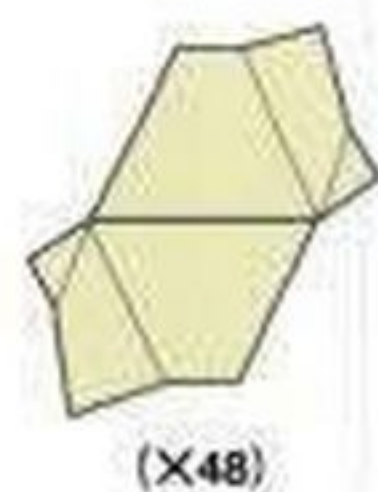



Double-sided convex hexagonal ring (p. 54)

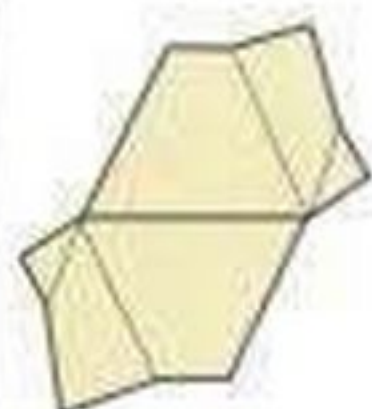

(X90)

Begin with a 5-unit structure.

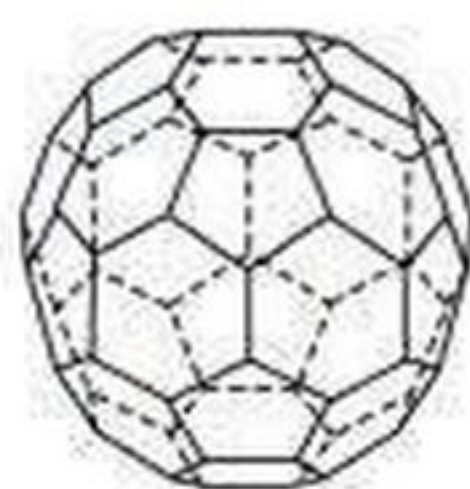
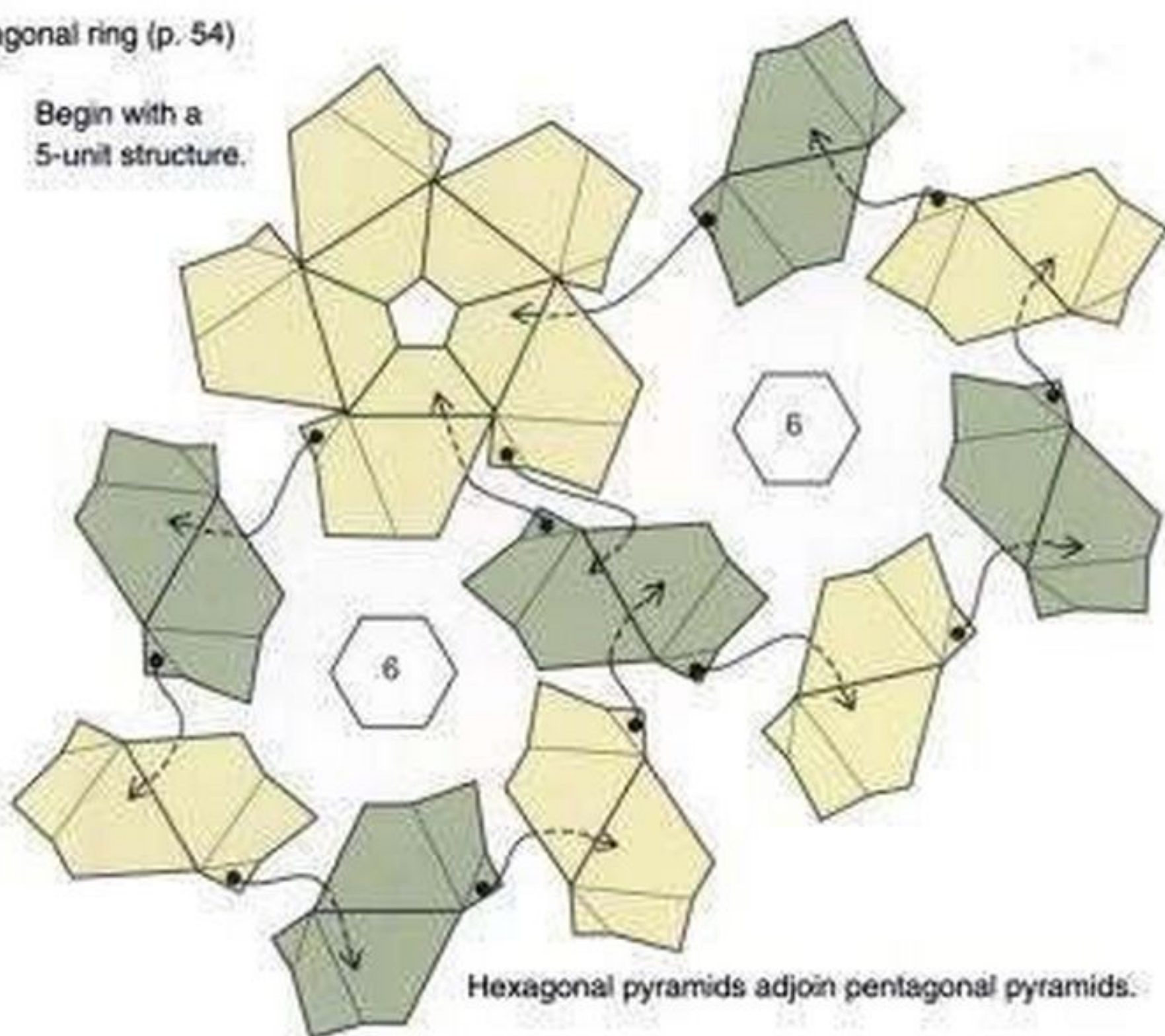

○ X12 ○ X20

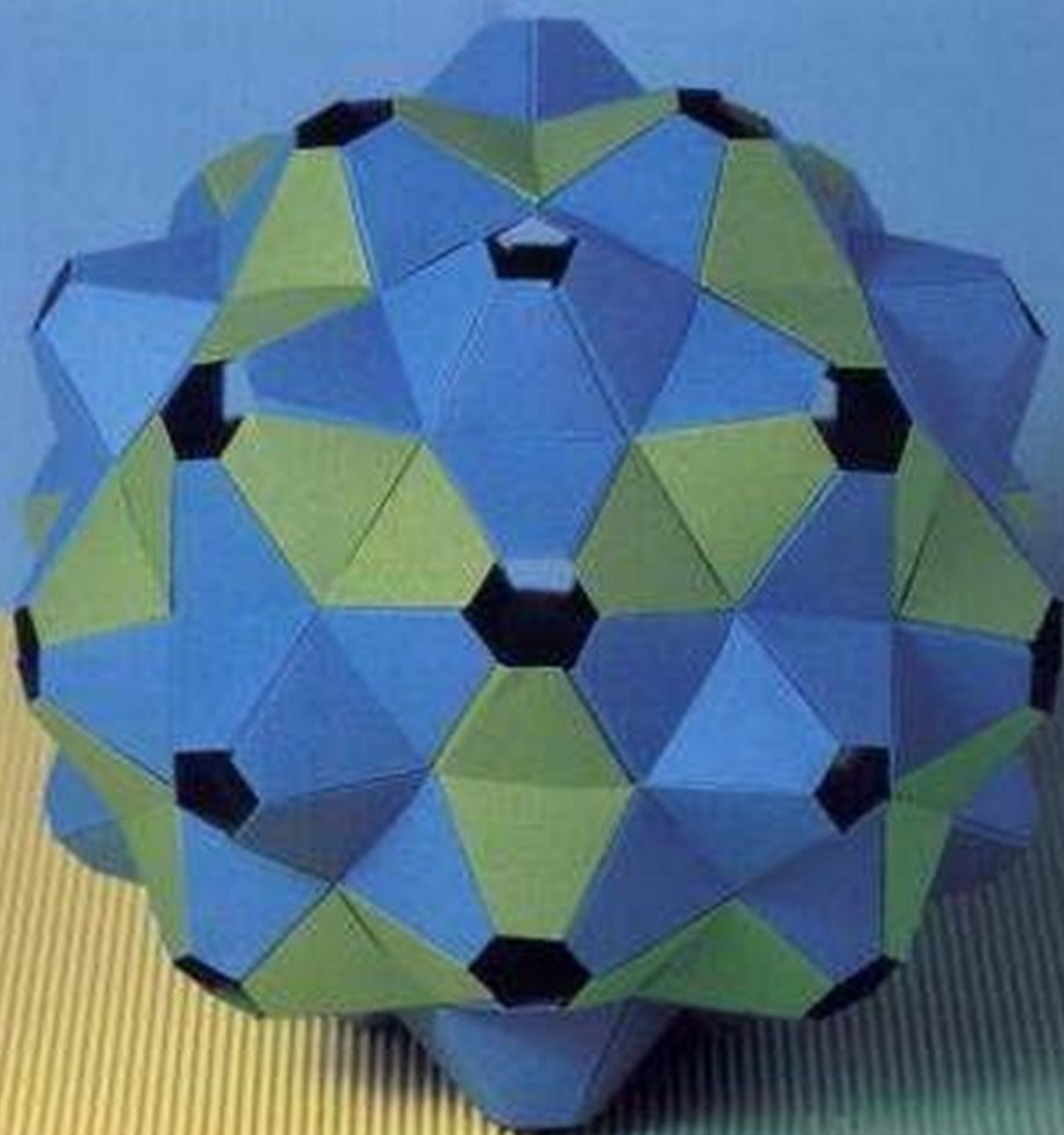



Double-sided convex hexagonal ring (p. 54)



(X120)

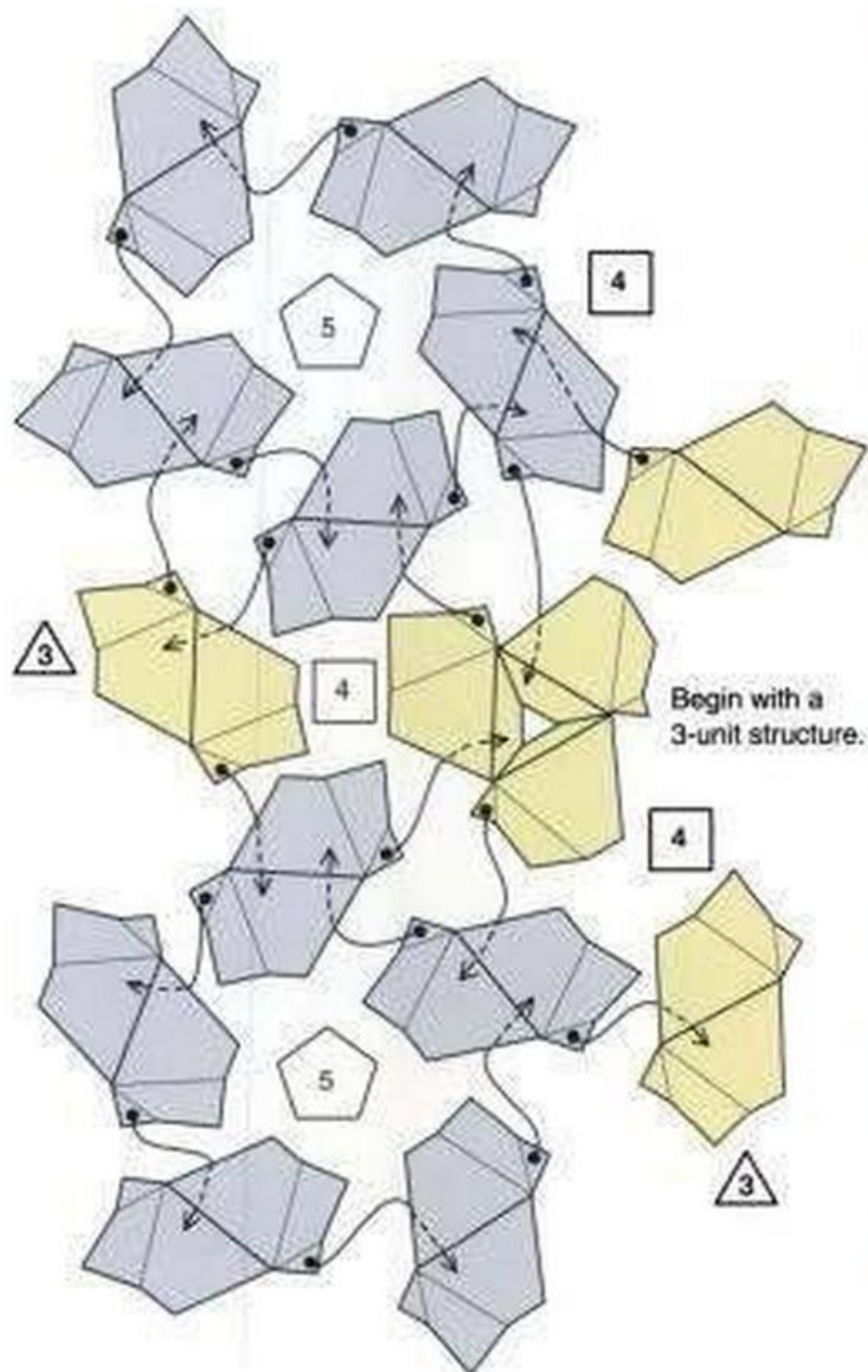

The sides that adjoin the pentagon are square.  
The sides that adjoin the triangle are square.

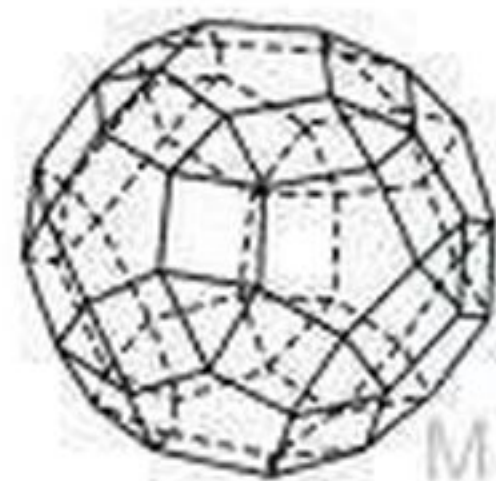

- △ ×20
- ×30
- ⬠ ×12



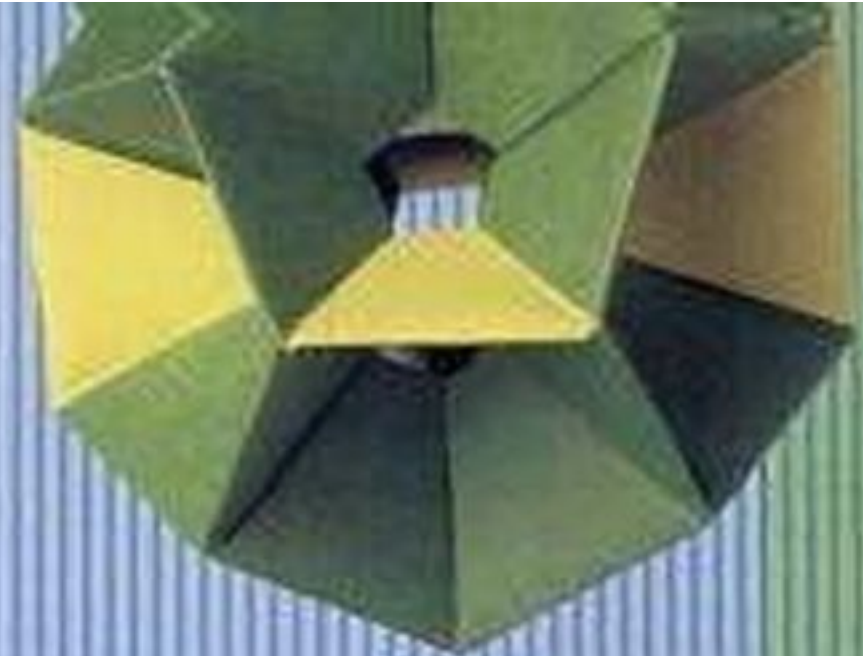

**30-UNIT STRUCTURE** /p.71

**90-UNIT STRUCTURE** /p.75

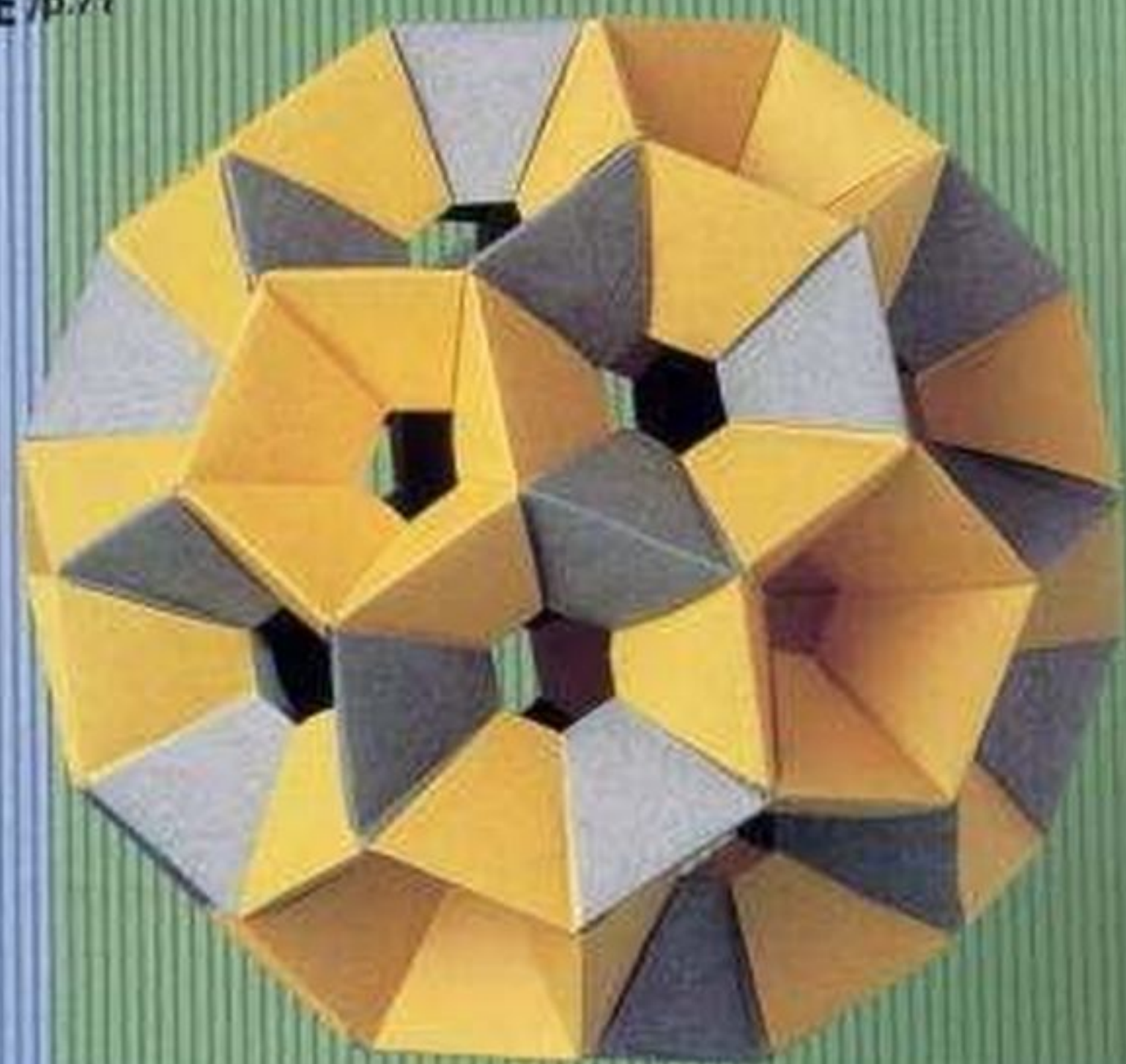

**36-UNIT STRUCTURE** /p.72

**36-UNIT STRUCTURE** /p.70

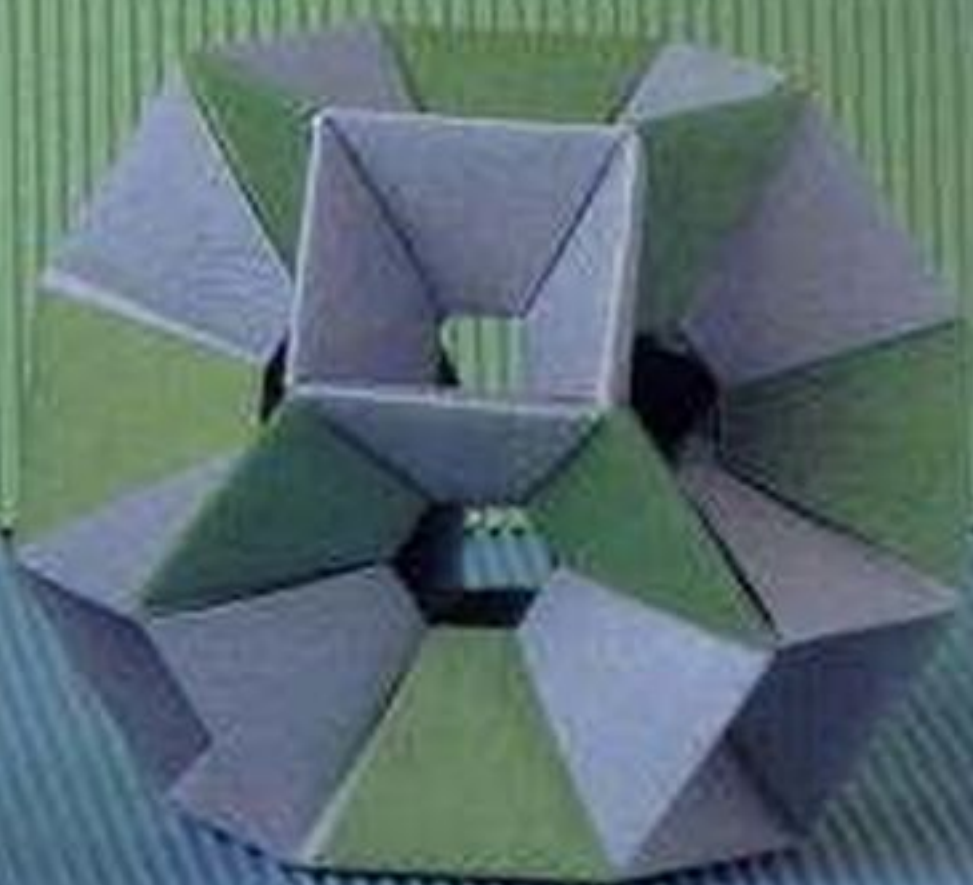



# DOUBLE-SIDED CONCAVE HEXAGONAL RING SOLID

level ★ 12cm × 16cm

The structure is the same as that of the double-sided convex hexagonal ring solid. However, you use a different folding method when assembling it in order to hide the extra lines. The finished works are sturdy, so glue is not necessary. Unit B, which is used in some structures, has a crease only on one side.

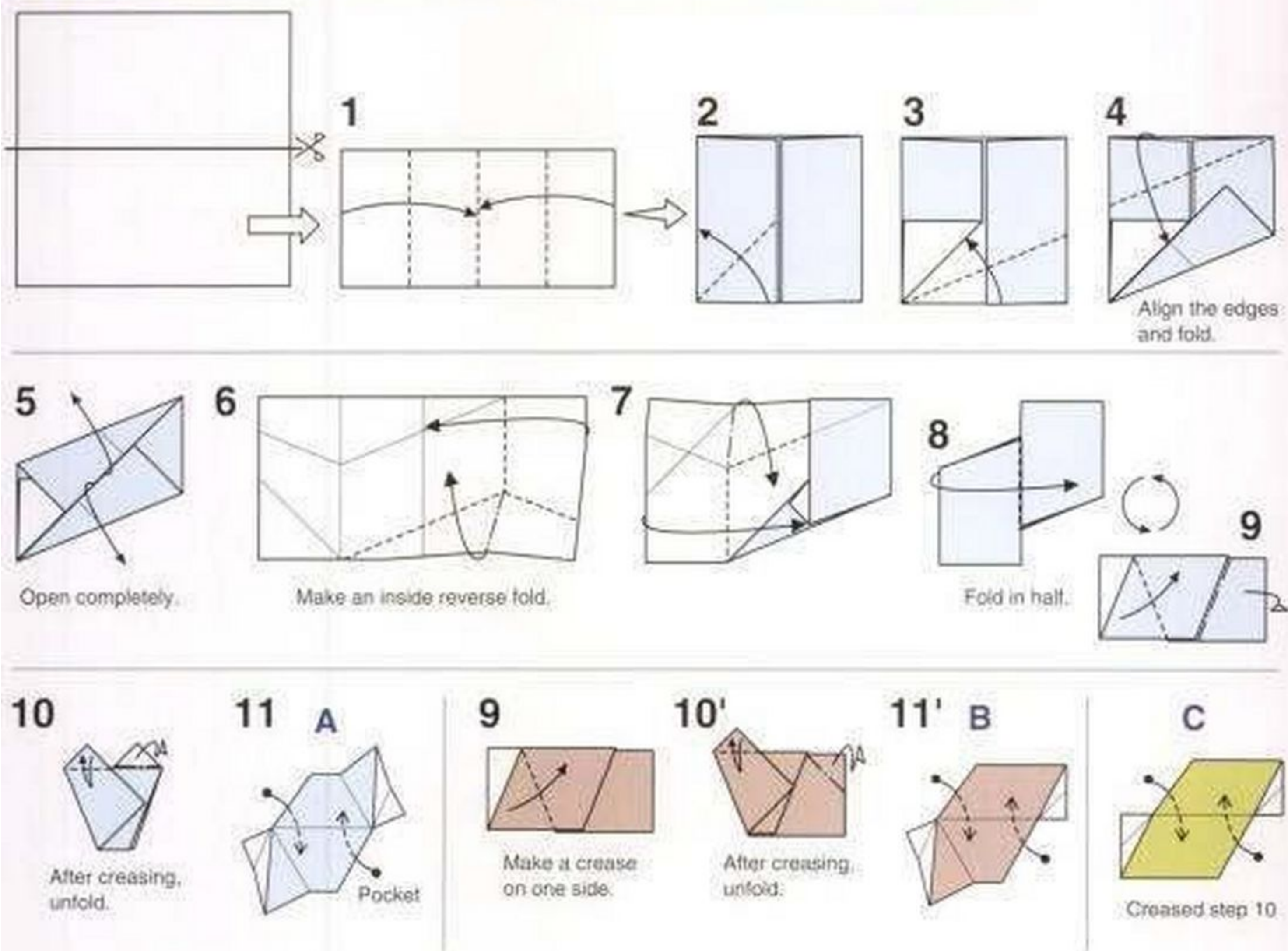

## HINT ON ASSEMBLY 1

Take special note of the small triangle (shaded) in step 10. This triangle hooks firmly and makes the unit sturdy.

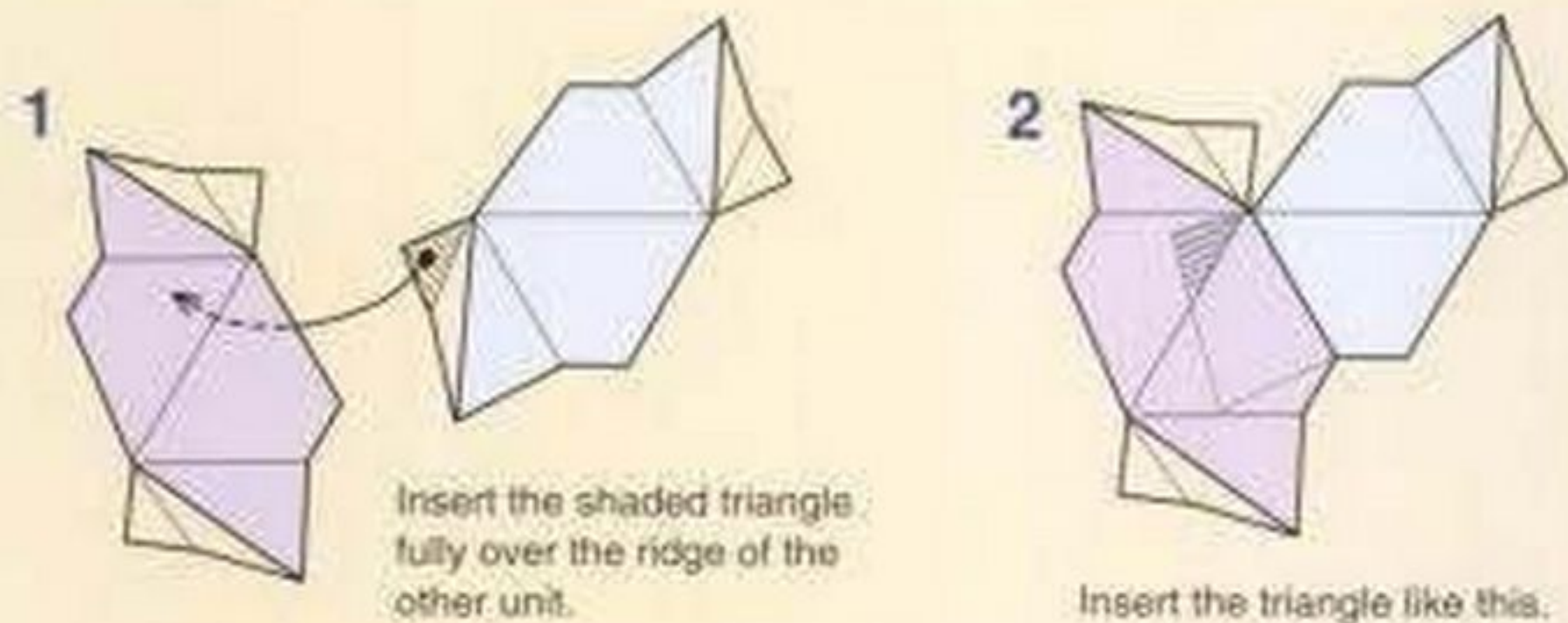



## HINT ON ASSEMBLY 2

As is seen in the figures, the units are indented along the ridges. You can assemble various kinds of solids by making use of them.

One example is a truncated octahedron. It consists of squares and hexagons.

First, make 4-unit structures and put them together so that the hexagons are connected adjoin around the square indentation.

Begin with the smallest structure (a 4-unit structure in this case). Make it the core, and expand it by connecting additional units one by one.

### Truncated Octahedron

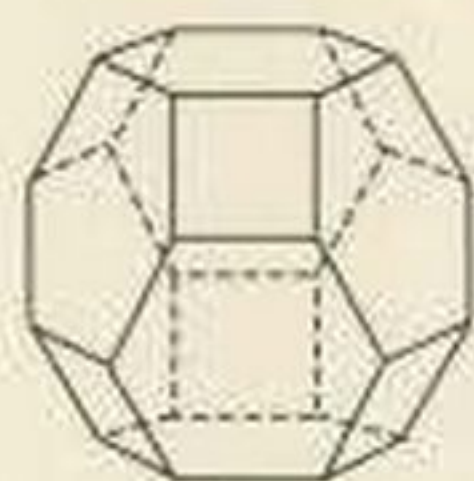

□ × 6  
○ × 8

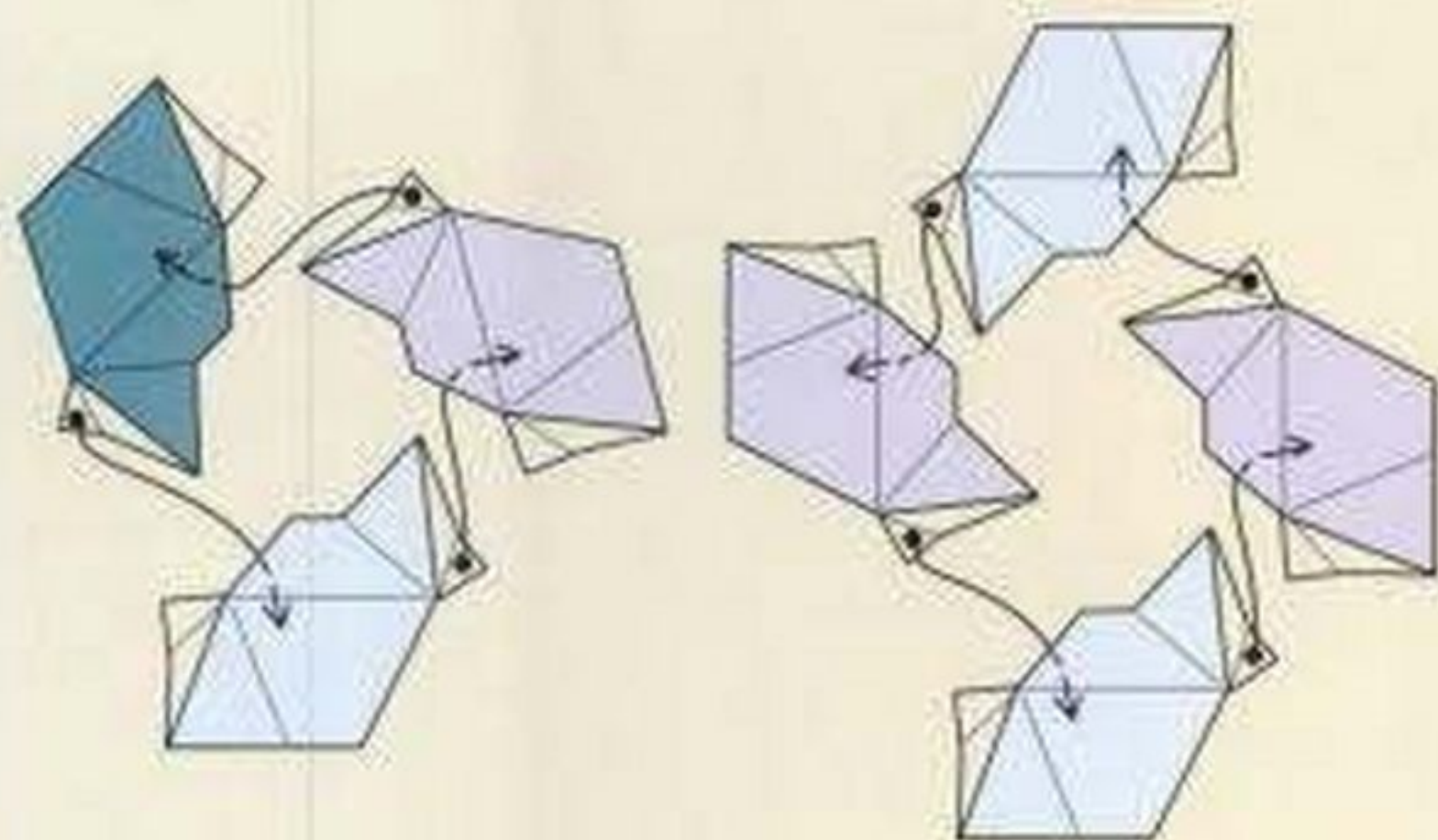

Assemble 5-unit and 6-unit structures in the same fashion.

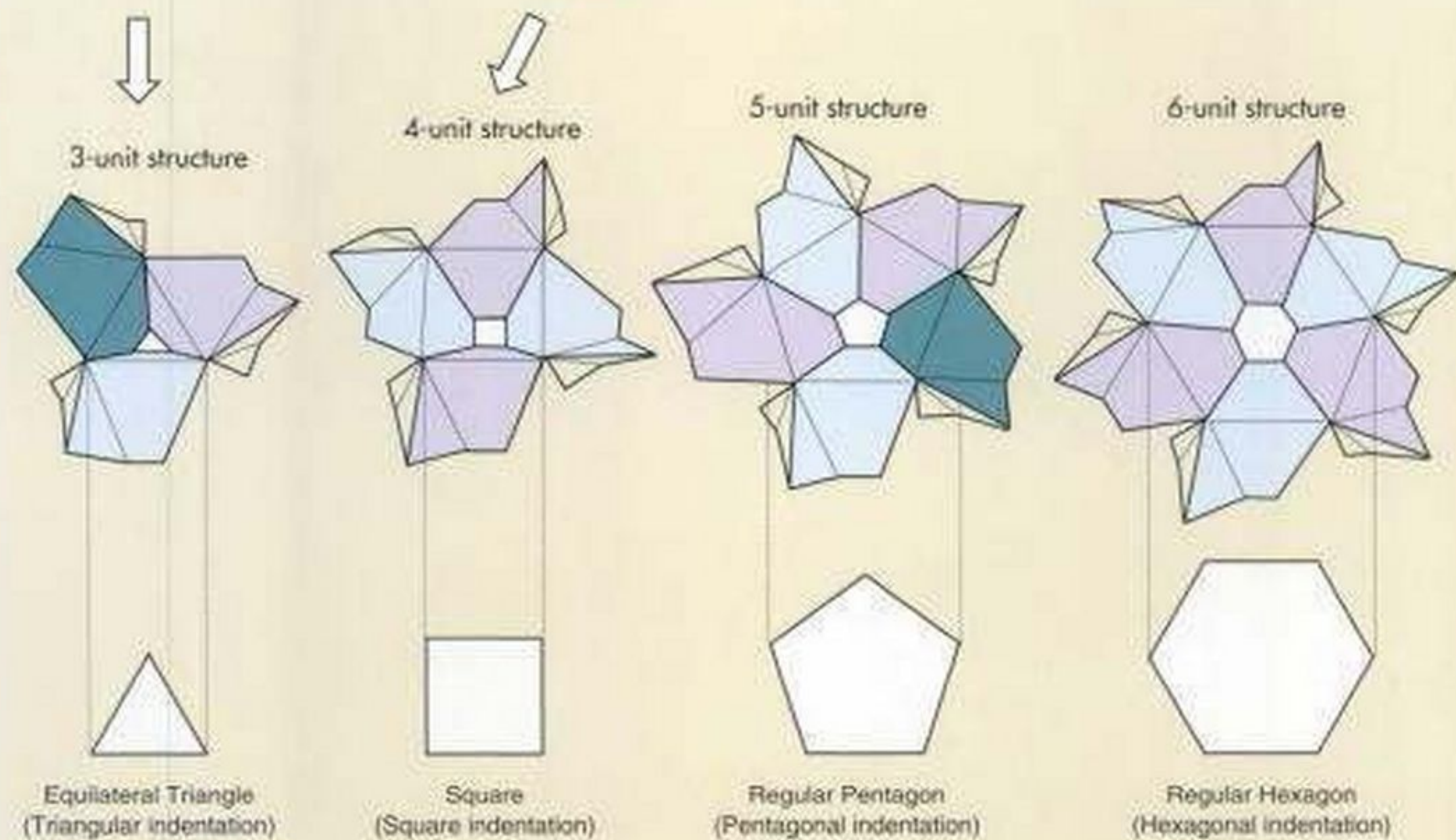



Double-sided concave hexagonal ring (p.68):

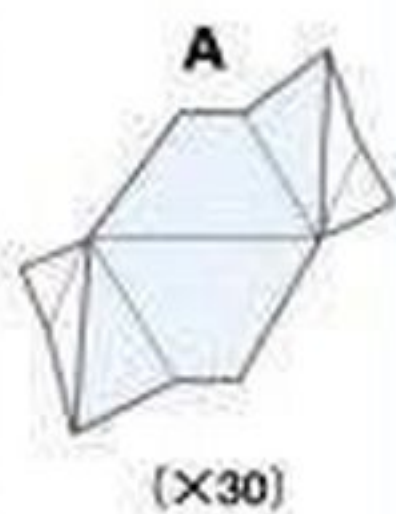

Begin with a 5-unit structure.

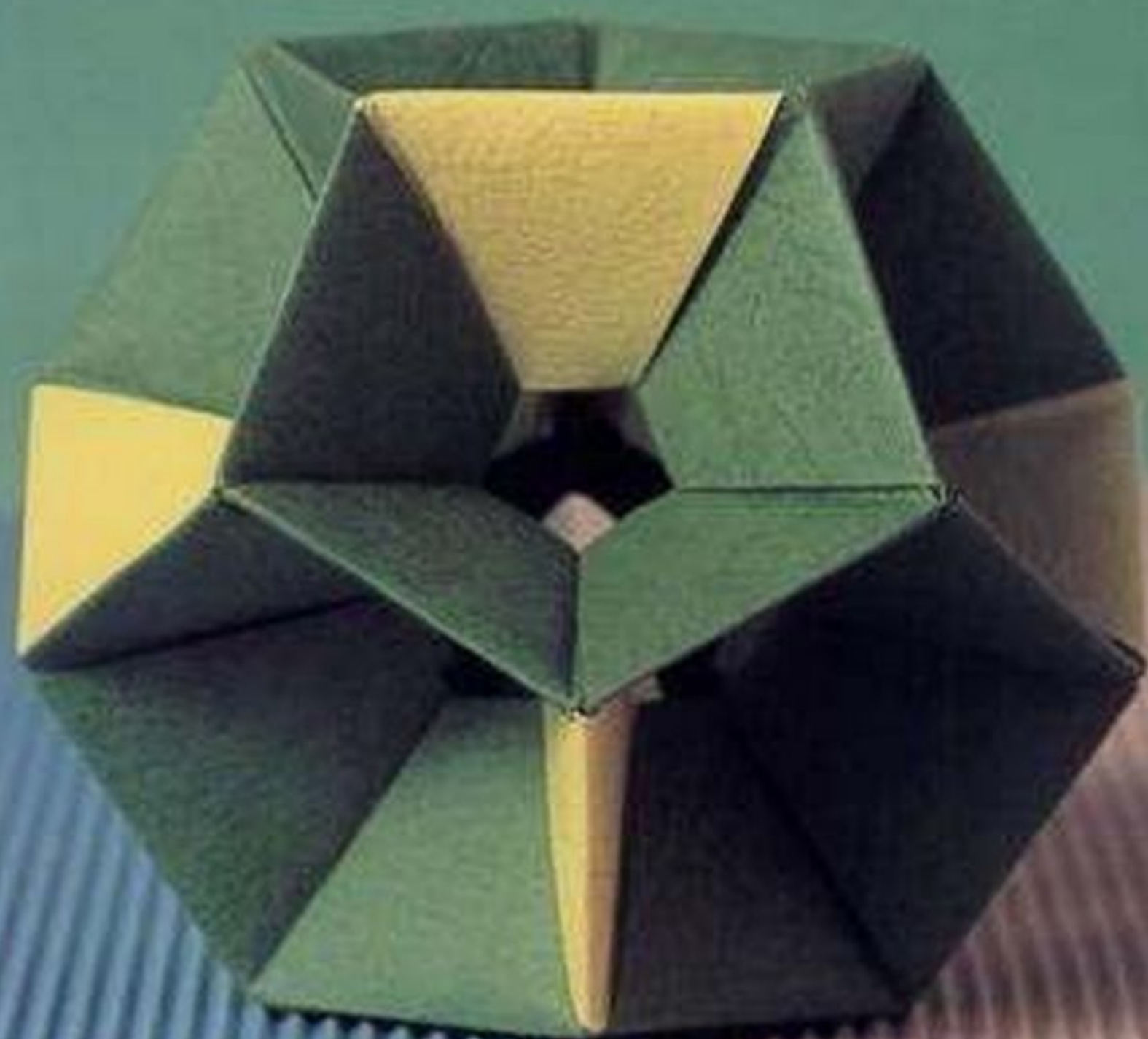
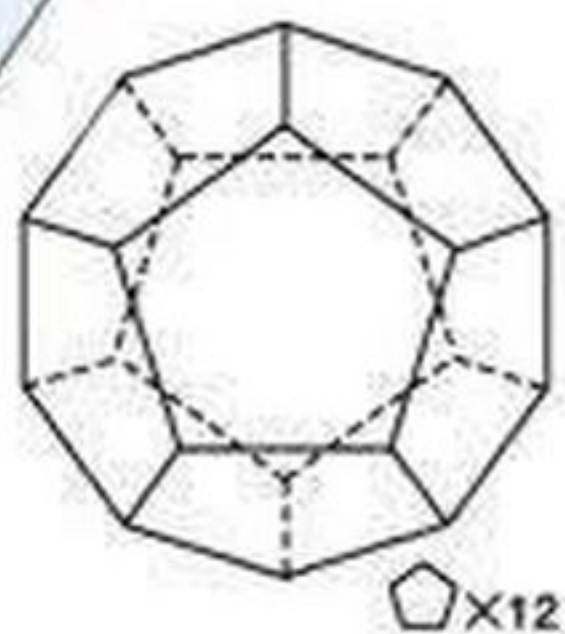
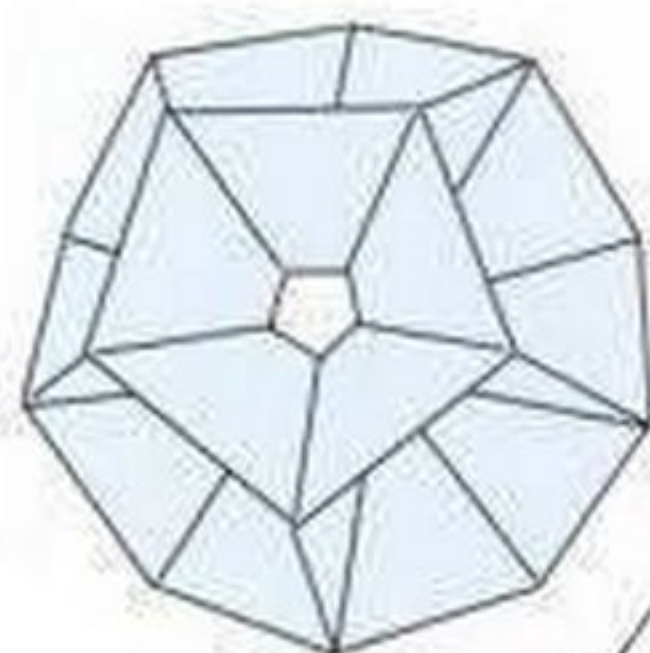
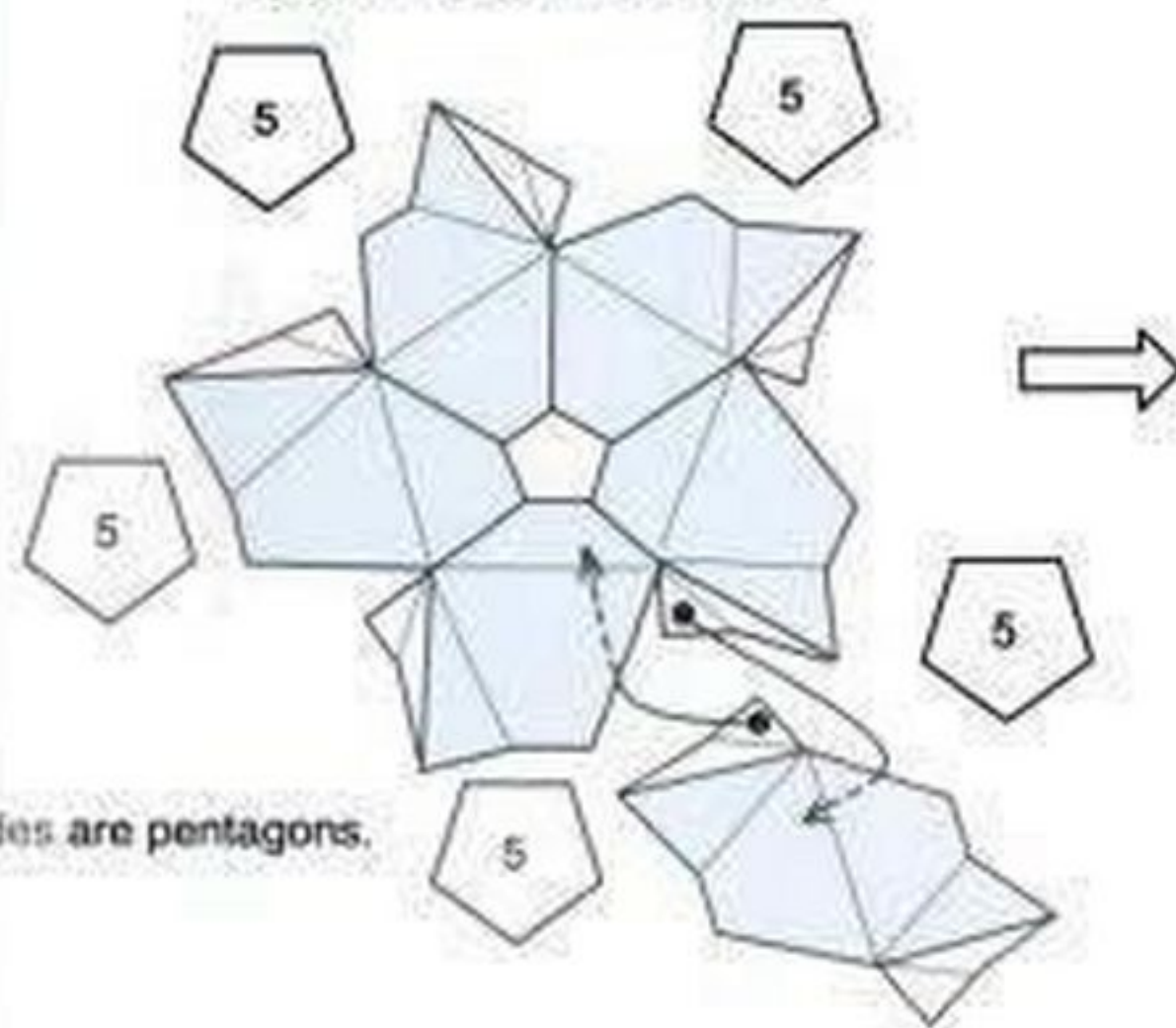



Double-sided concave hexagonal ring (p.68)

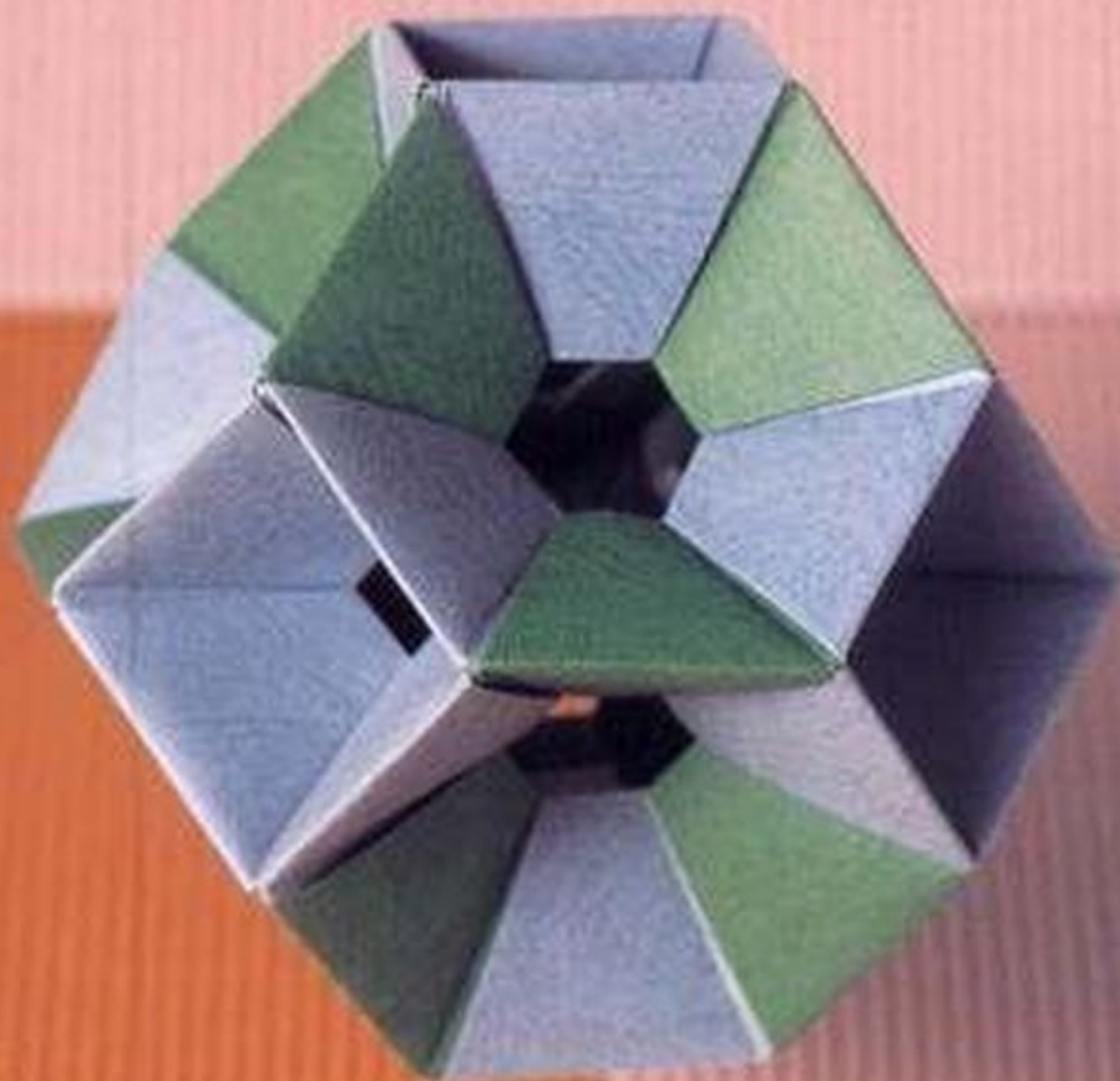
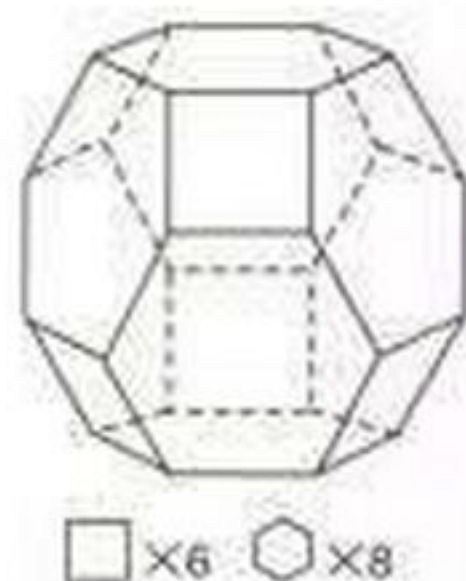
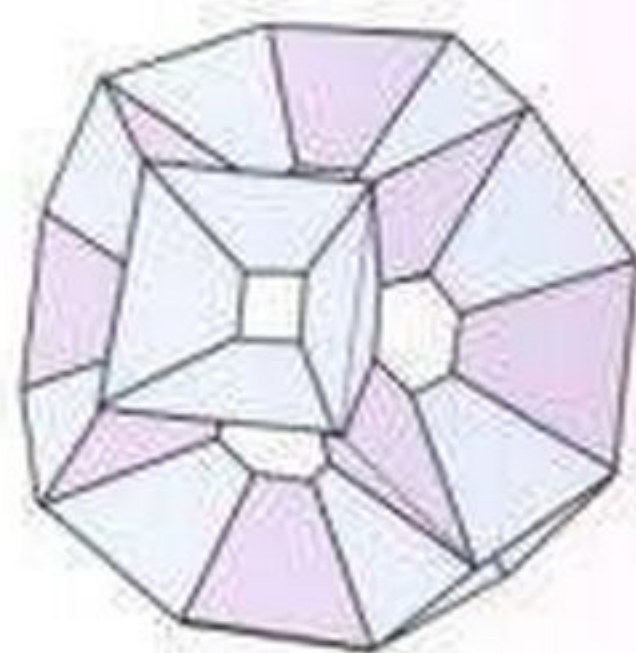
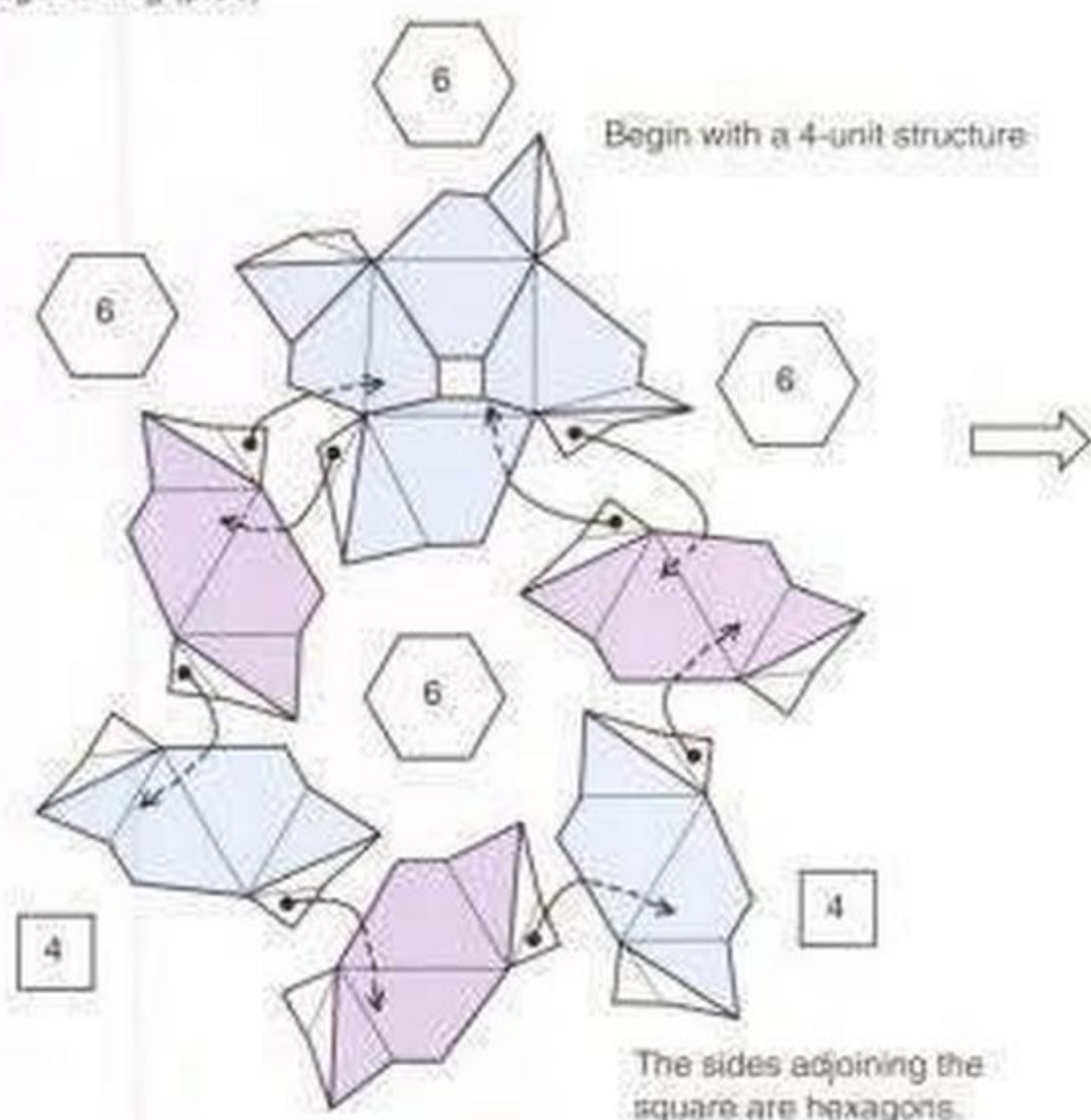
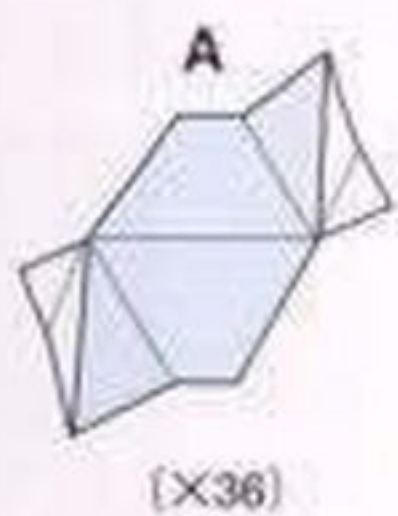



Double-sided concave hexagonal ring (p.68)

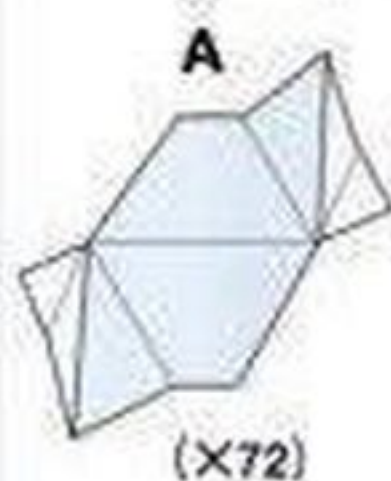

Begin with a 4-unit structure.

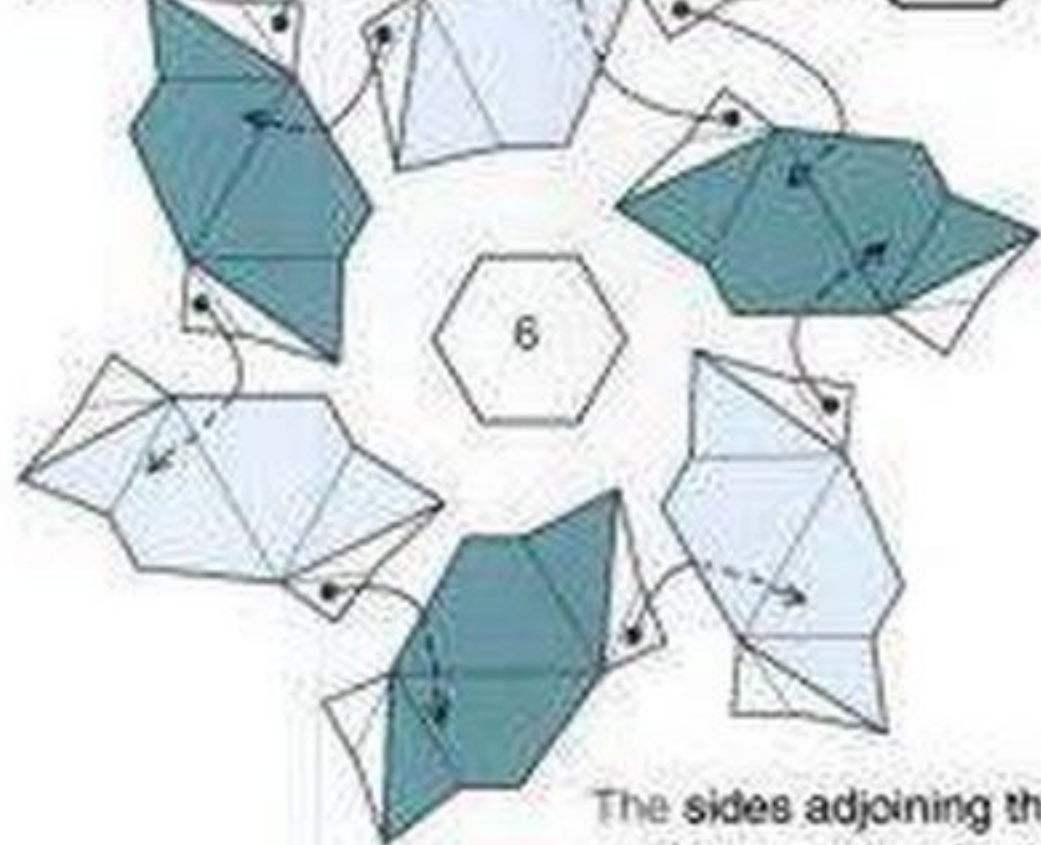

The sides adjoining the square are hexagons and octagons.

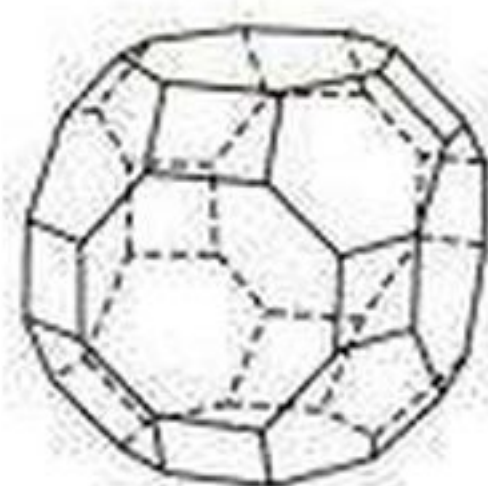
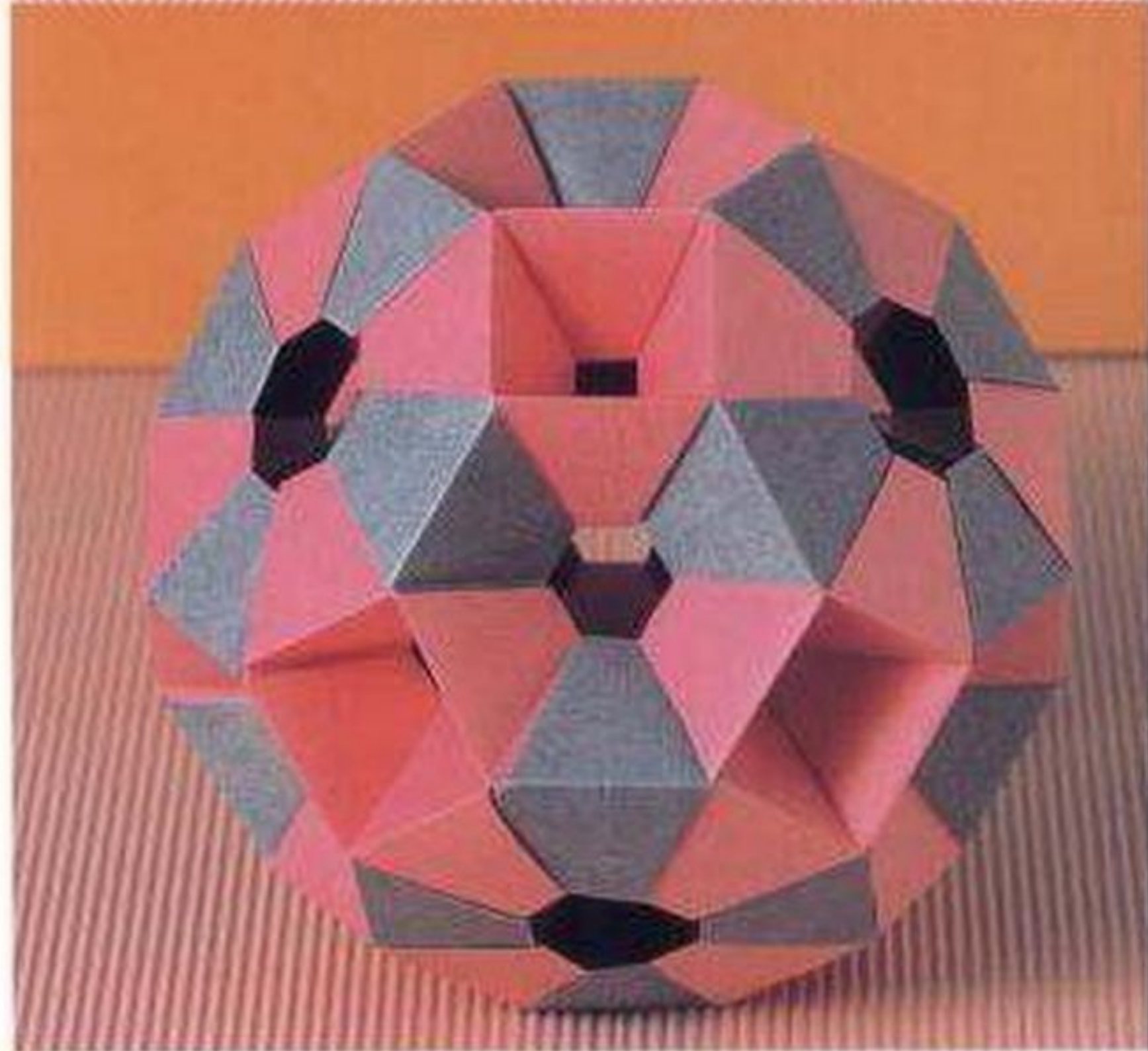
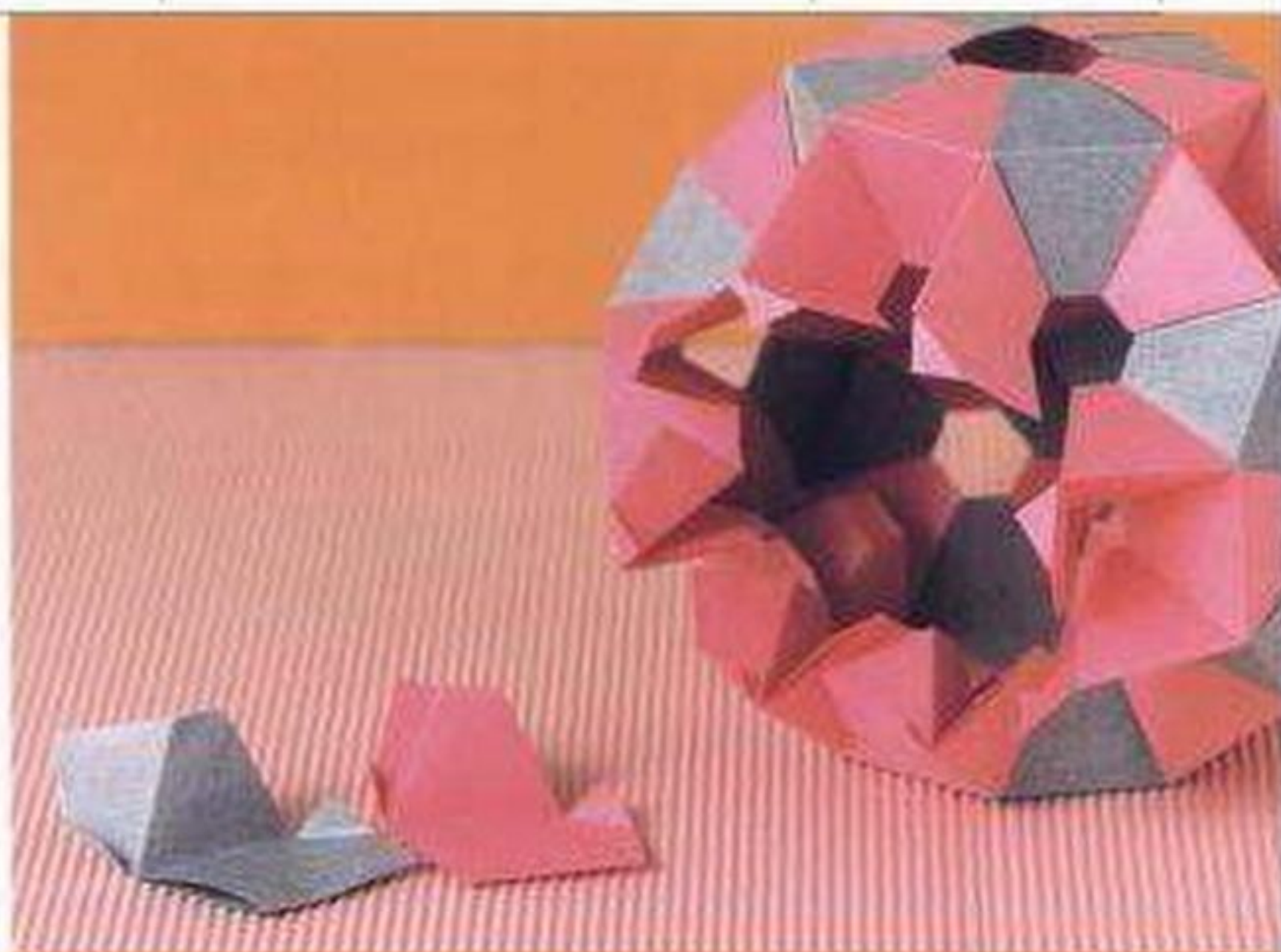
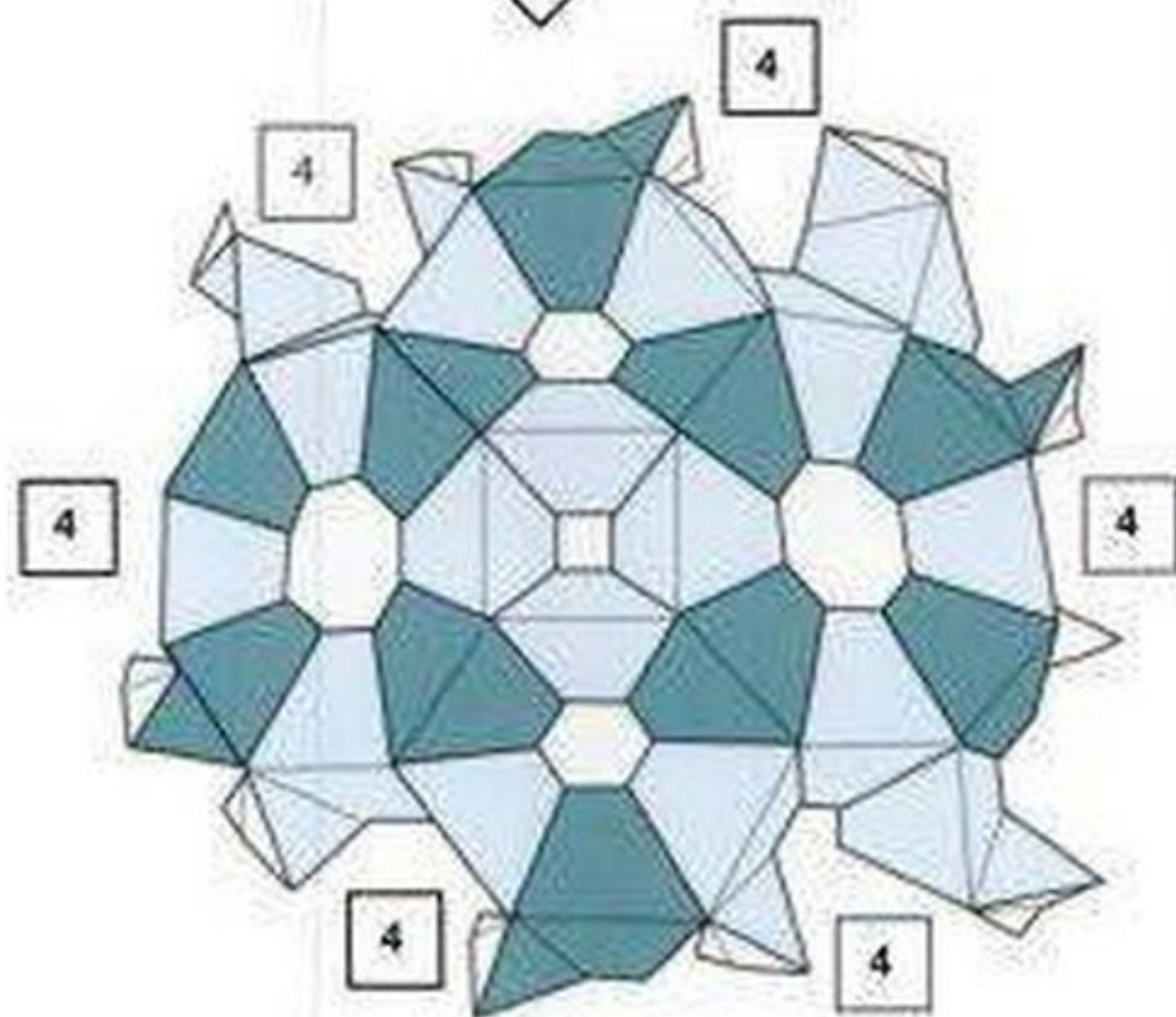

- X12
- ⬡ X8
- ⊝ X6



Double-sided concave hexagonal ring (p.68)

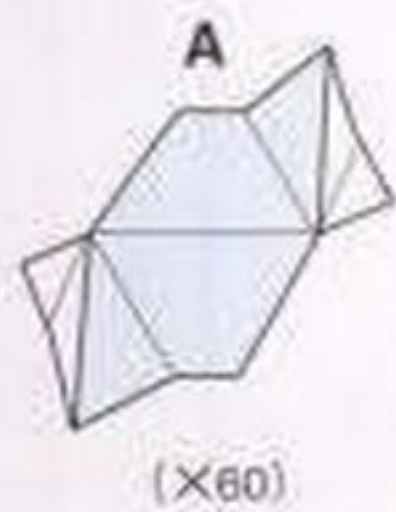

Begin with a 5-unit structure:

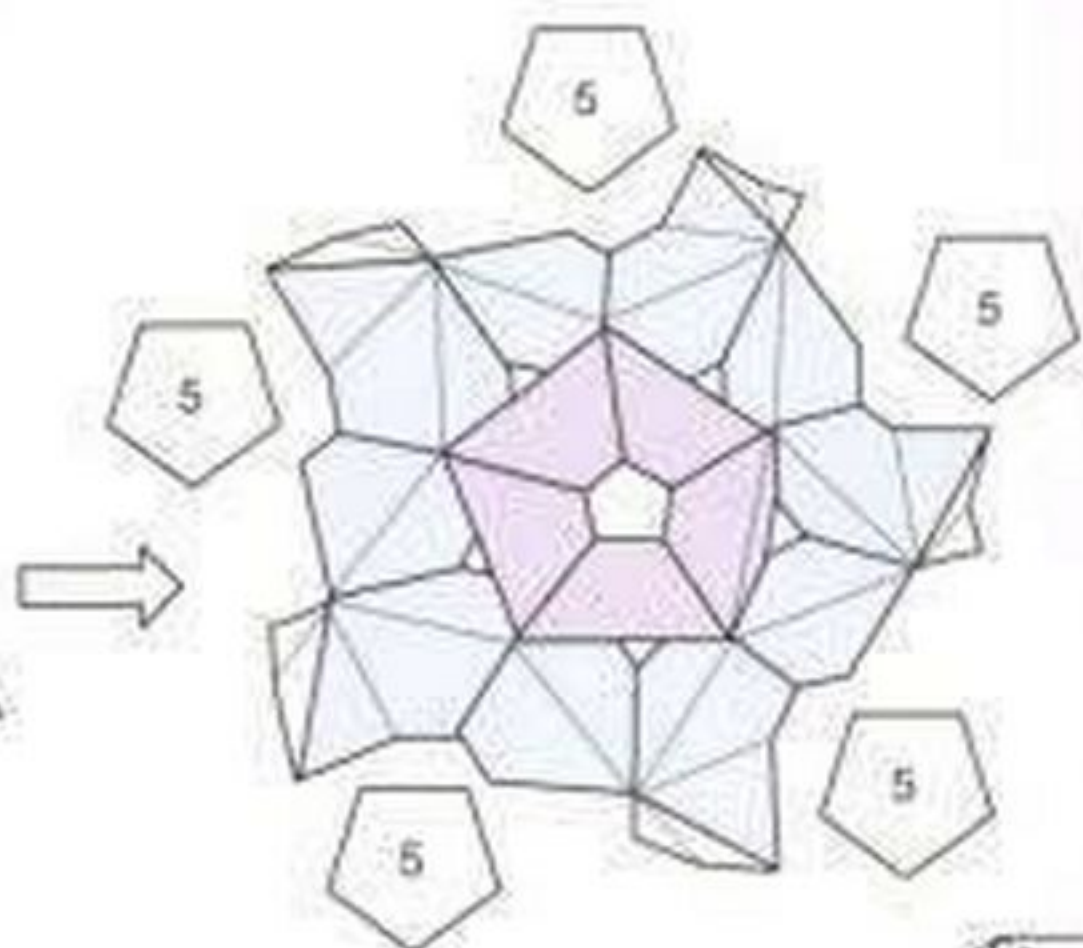
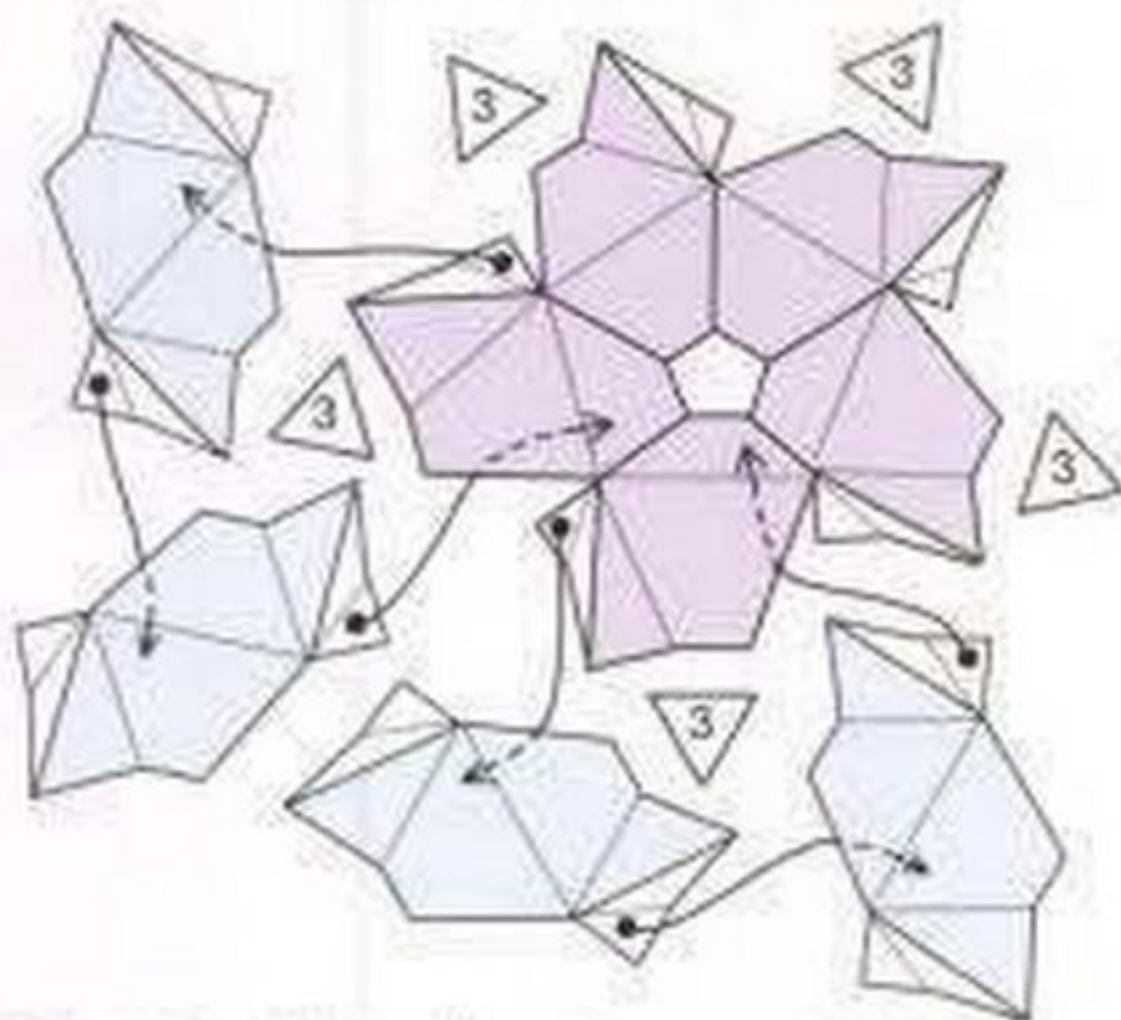

The sides adjoining the pentagon are triangles.

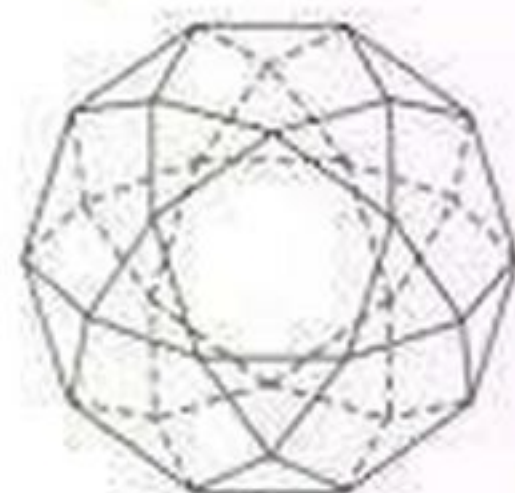

△×20    ◻×12

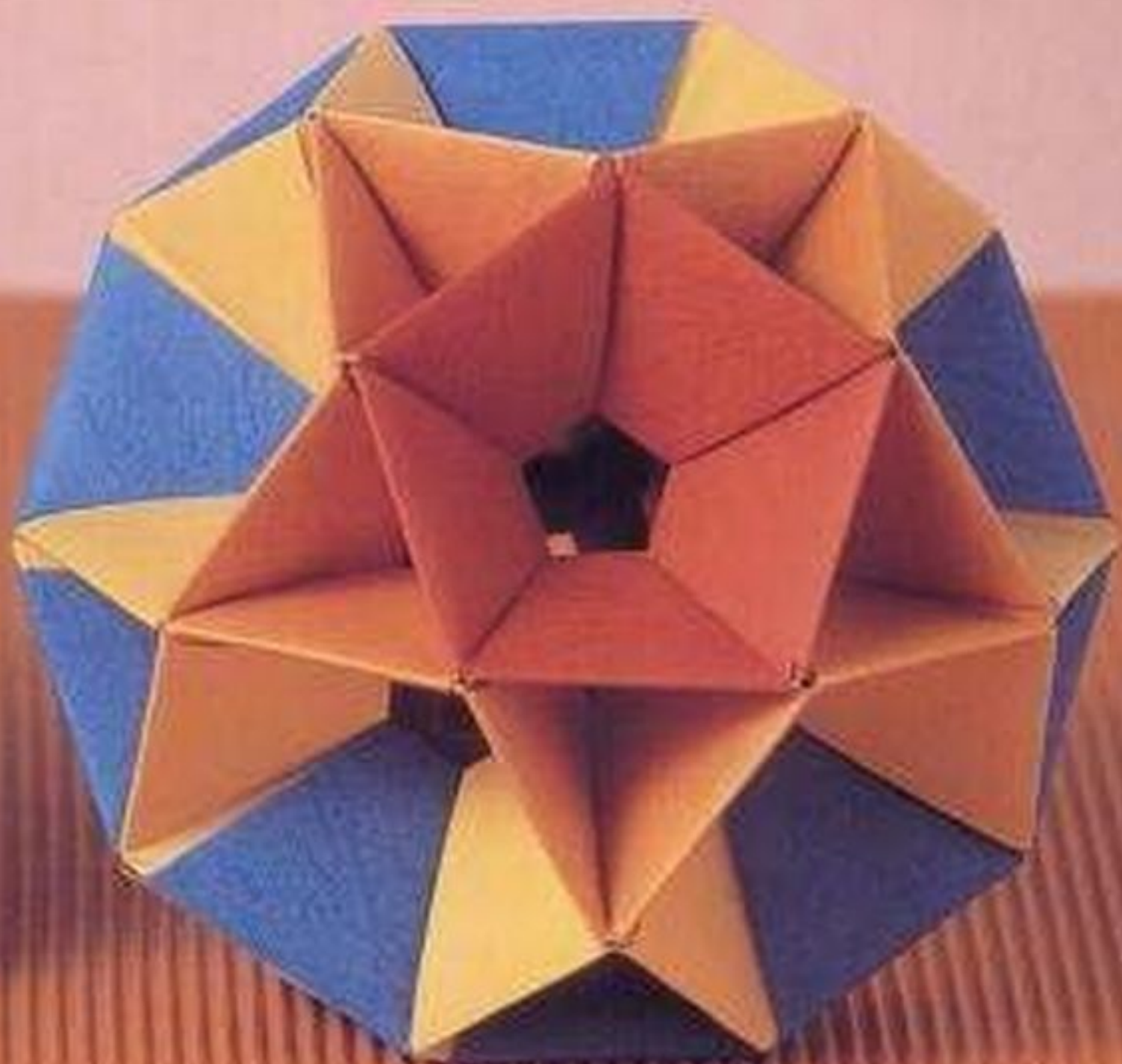
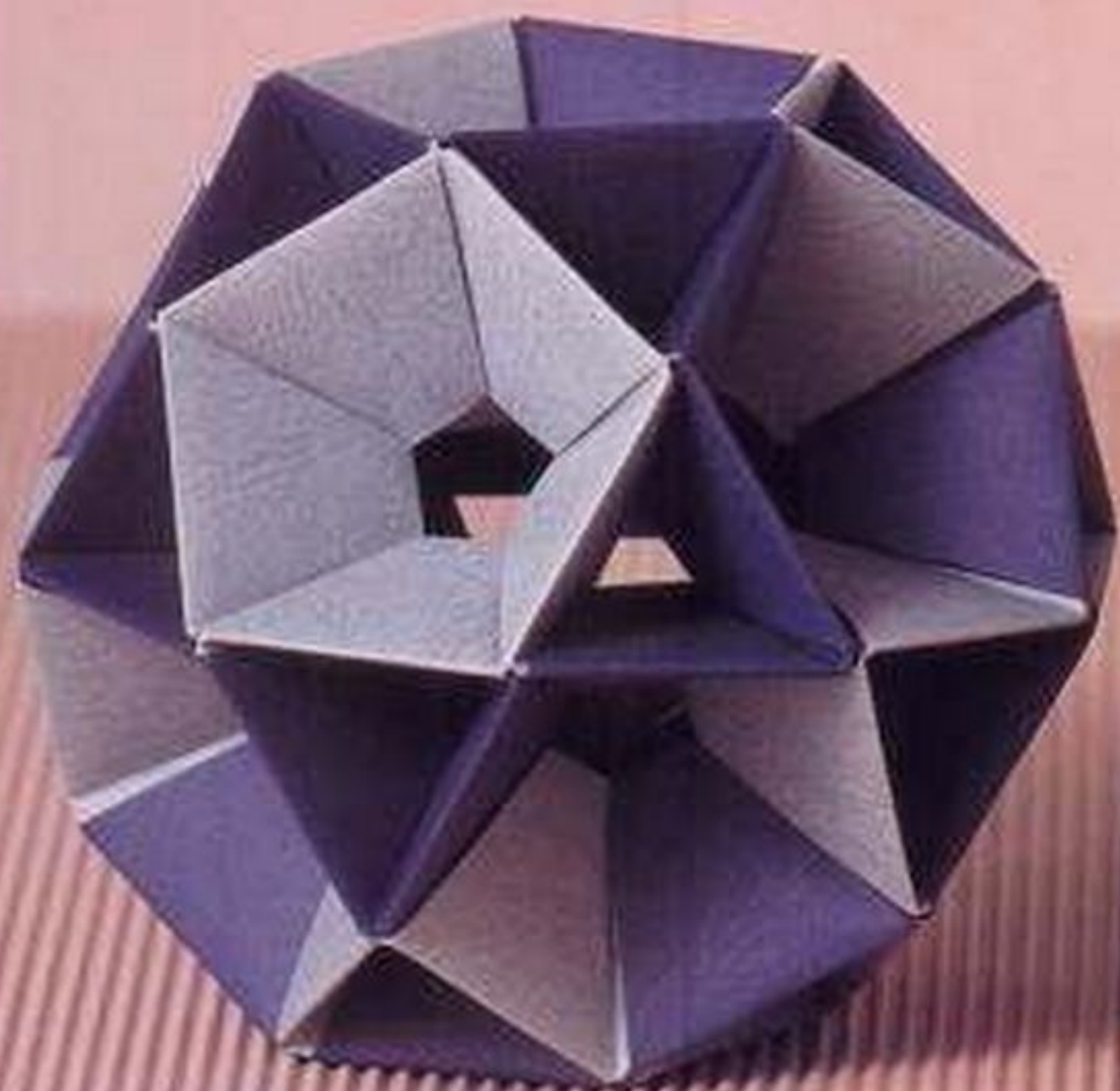



Double-sided concave hexagonal ring (p.68)

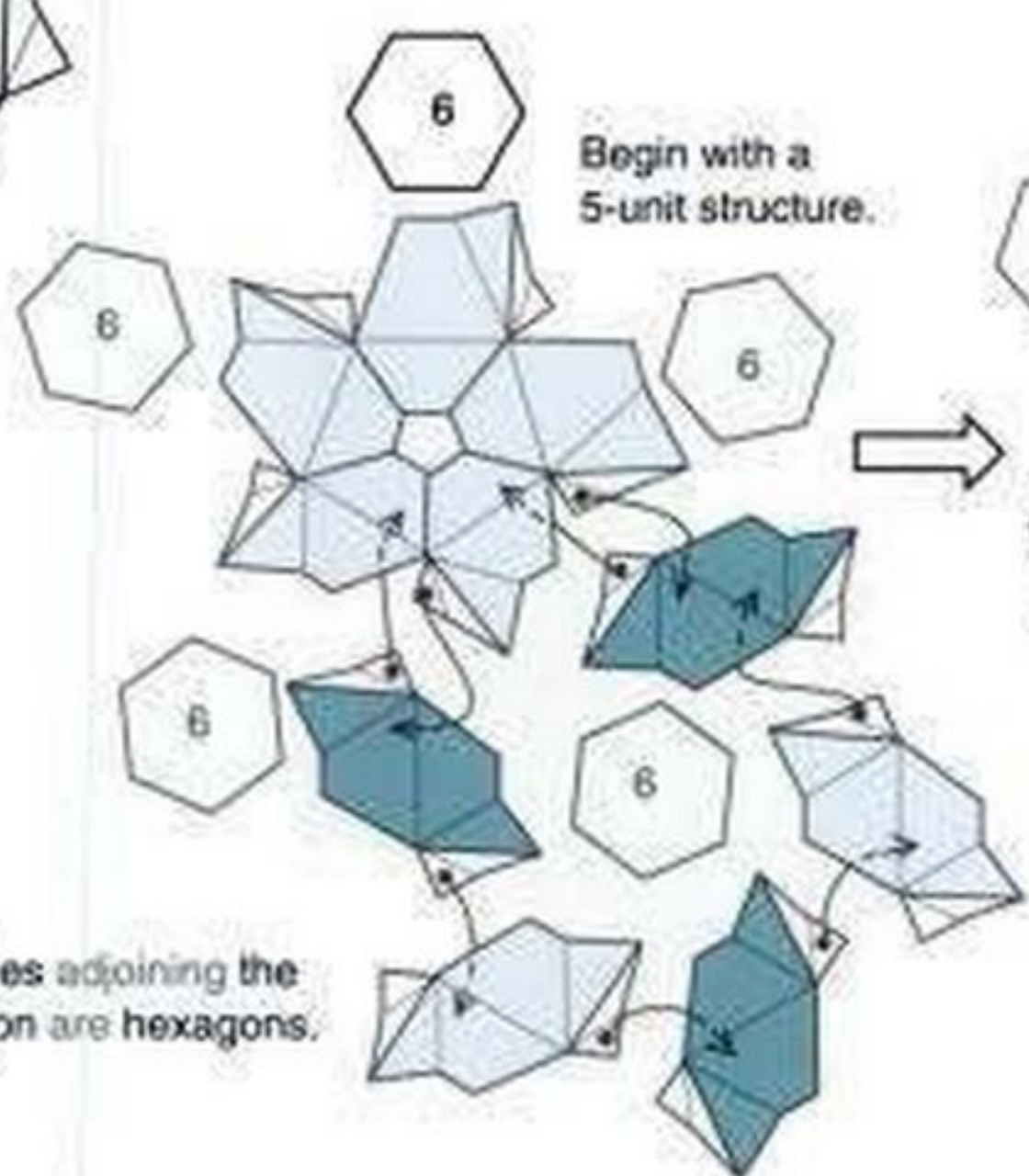
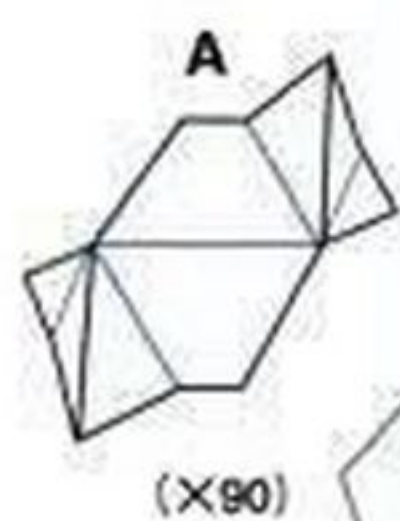

Begin with a 5-unit structure.

The sides adjoining the pentagon are hexagons.

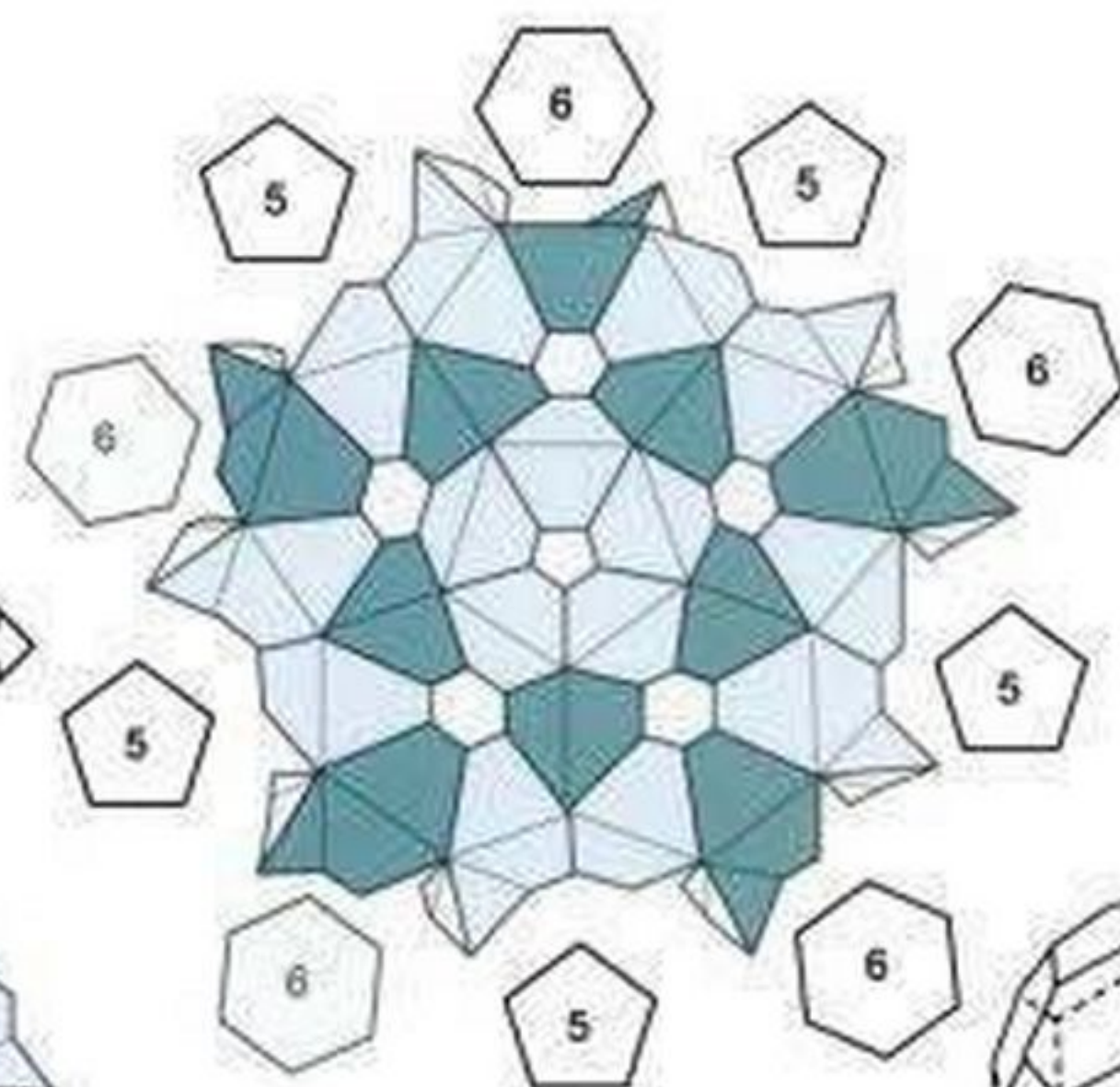

The sides adjoining the hexagon are hexagons and pentagons.

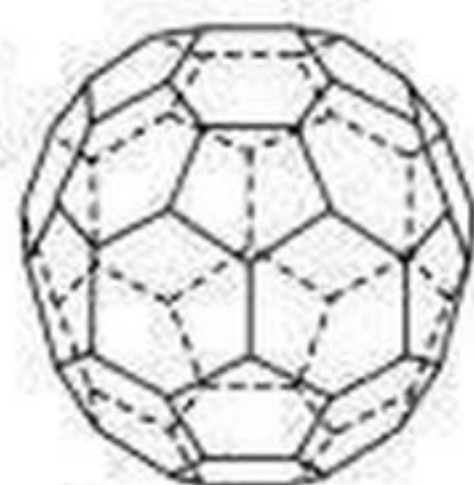

⬠ × 12   ⬡ × 20

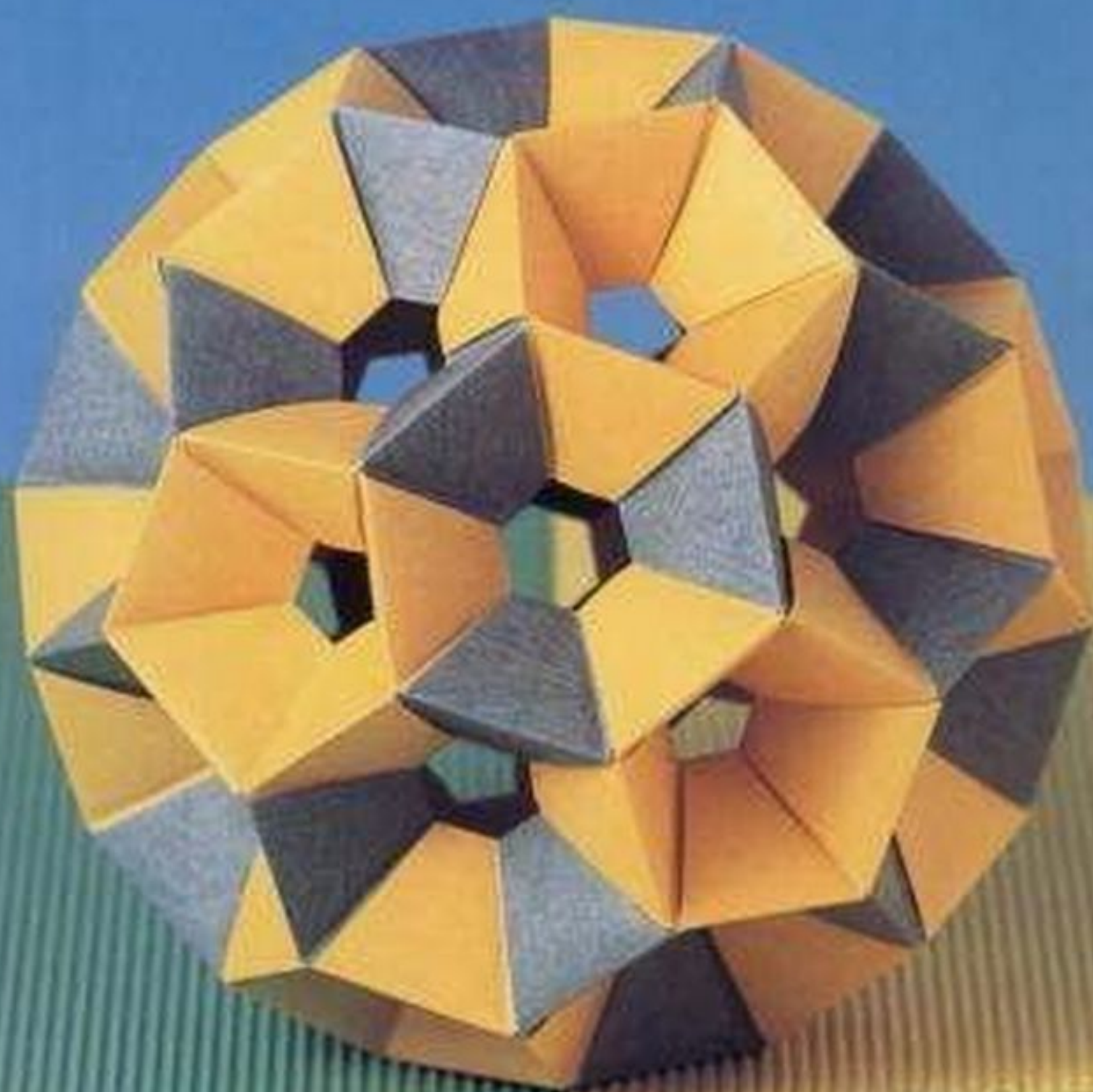



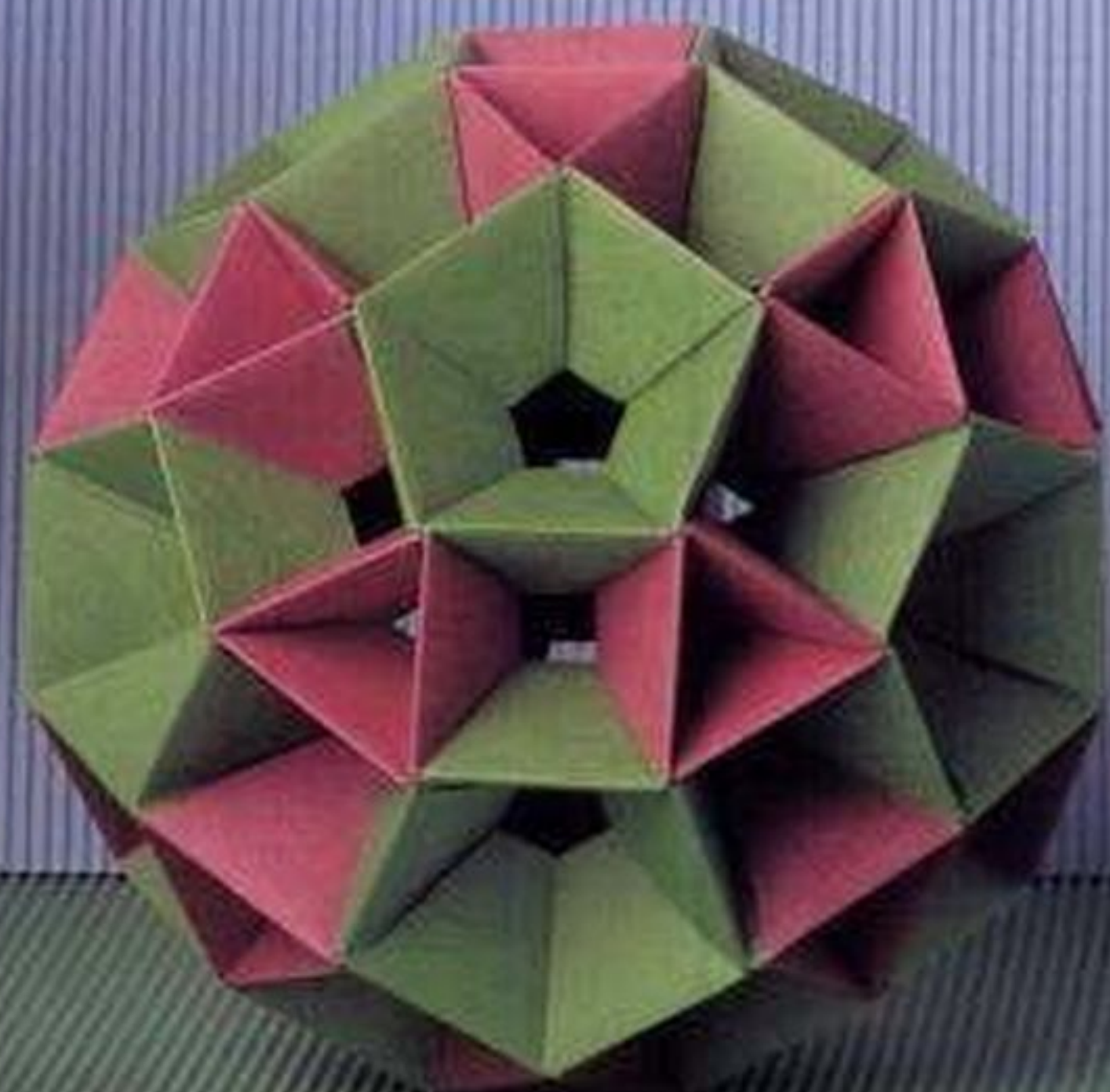

Double-sided concave hexagonal ring (p.68)

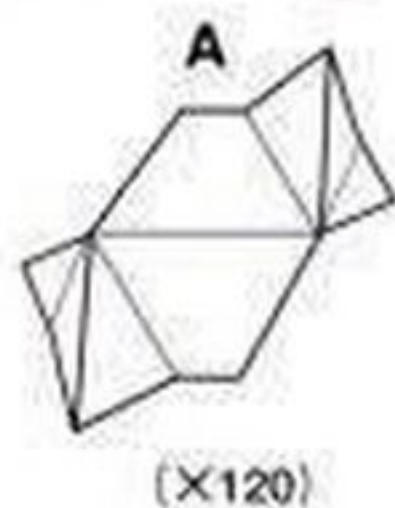

The sides adjoining the pentagon are squares.  
The sides adjoining the triangle are squares.

Begin with a  
5-unit structure.

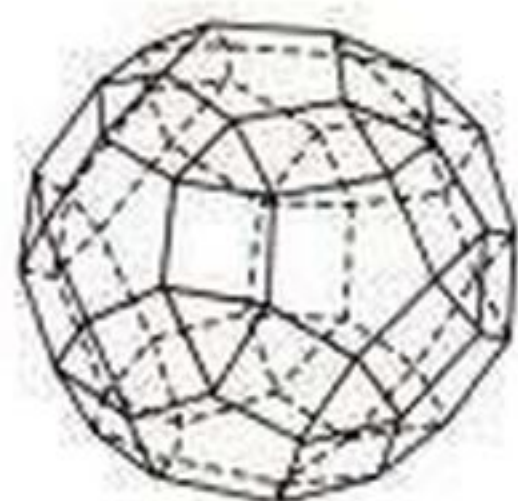
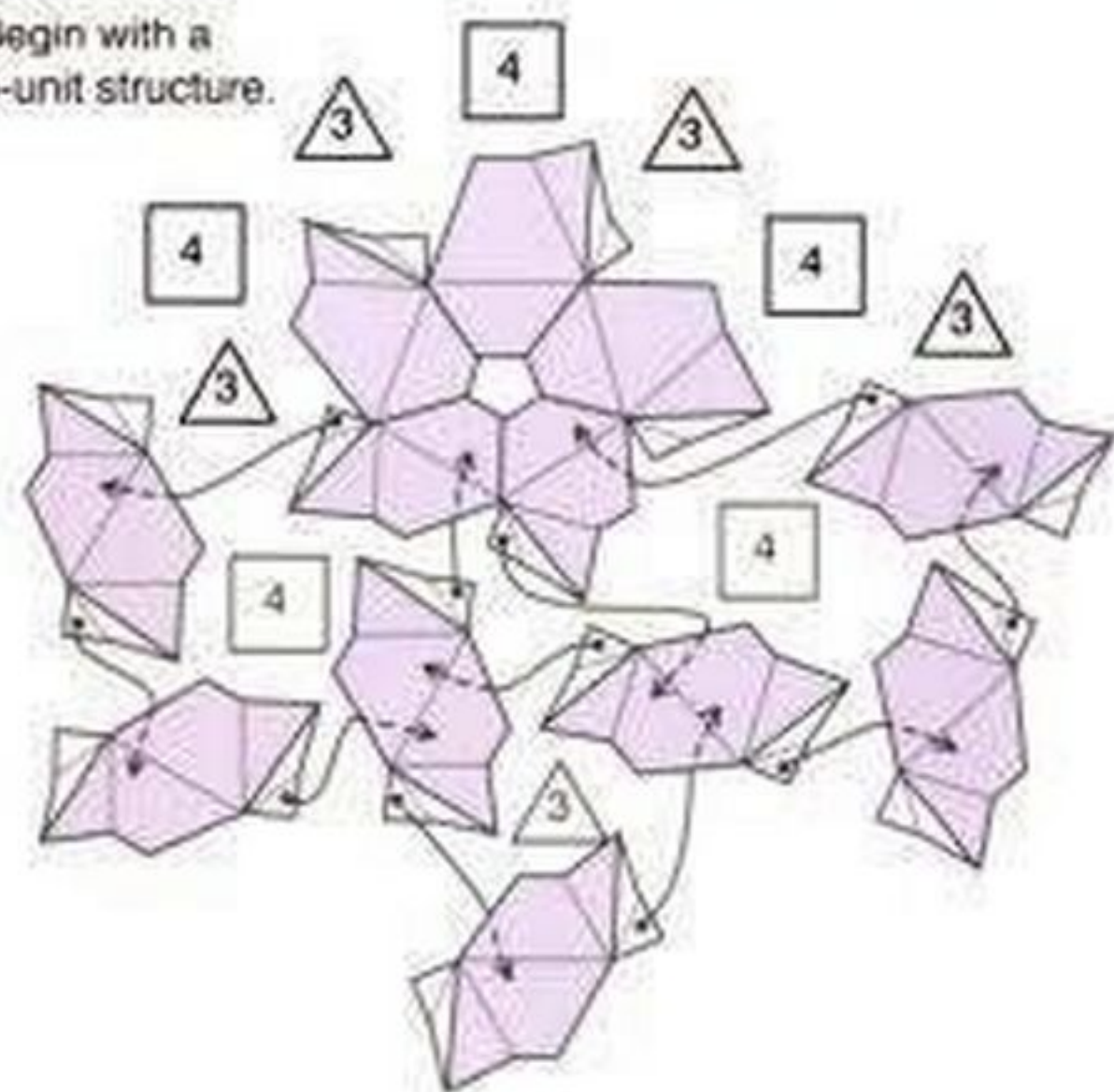

△ × 20   □ × 30   ▭ × 12



# Double-sided Hexagonal Rings FROM DIFFERENT SIZES OF PAPER | level ★

It is possible to fold double-sided convex and concave units from A4 (210 x 297 mm) or B5 (182 x 257 mm) paper. In that case, you end up with larger windows.

If you fold using square paper, the windows end up being too large and make the unit fragile.

A4 (210 x 297 mm) or  
B5 (182 x 257 mm)

## CONVEX TYPE

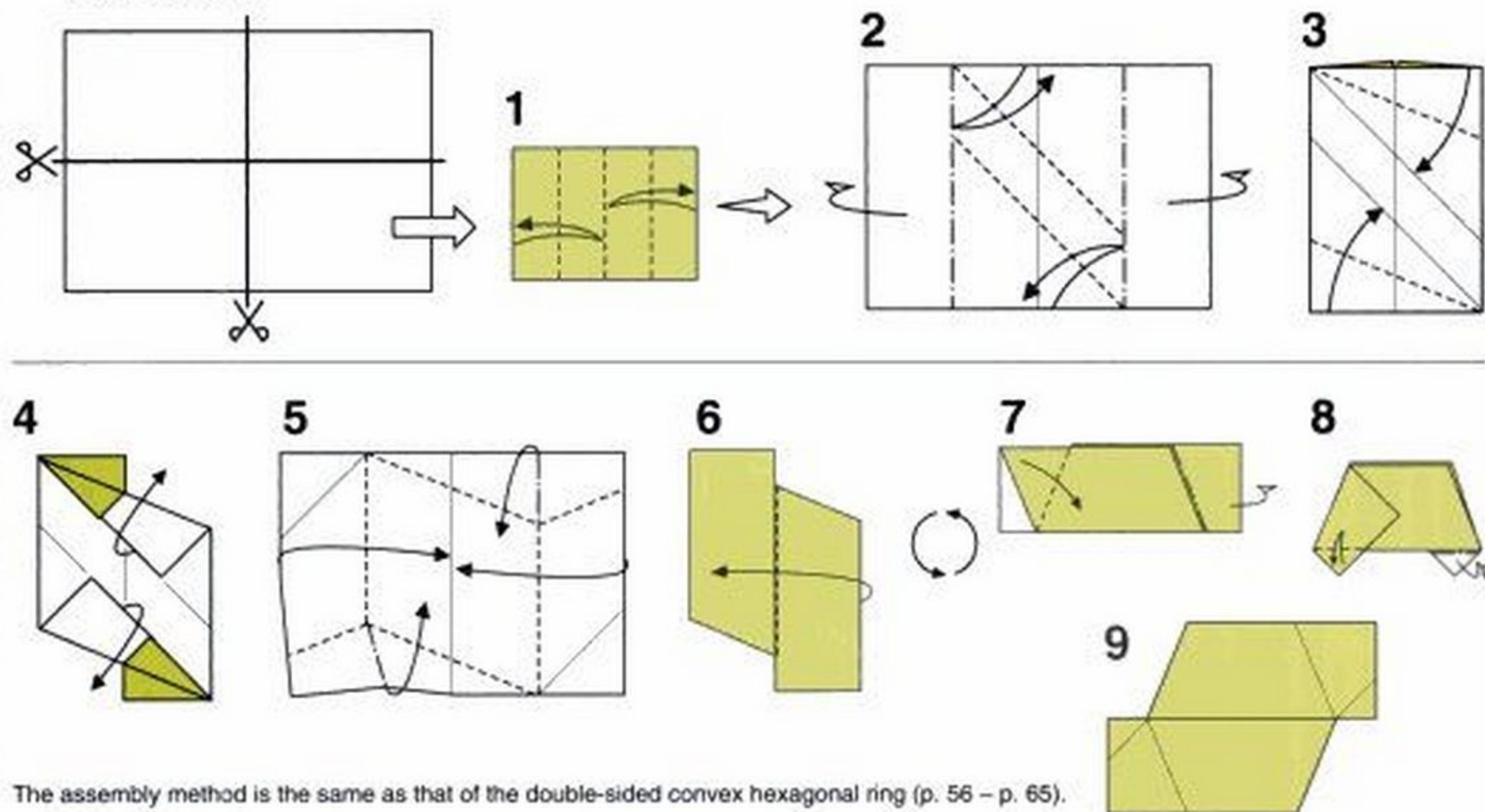

The assembly method is the same as that of the double-sided convex hexagonal ring (p. 56 – p. 65).

## CONCAVE TYPE

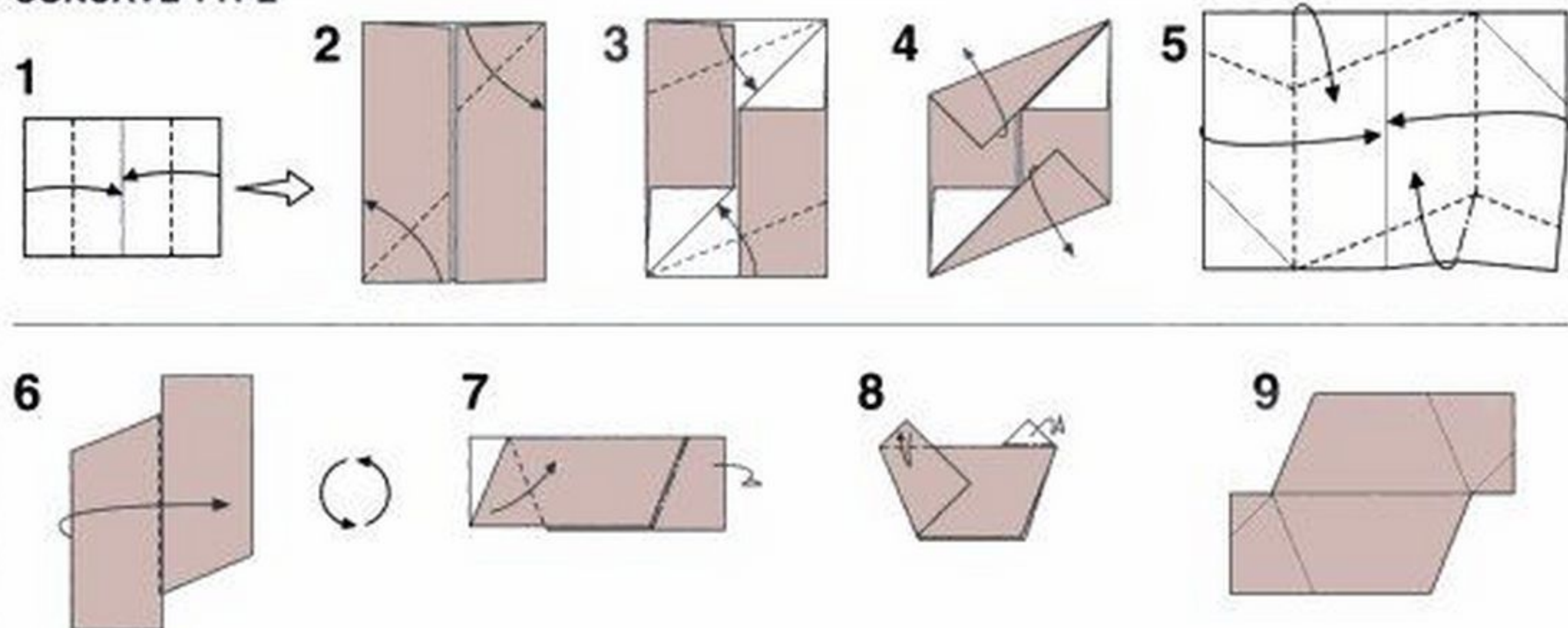

The assembly method is the same as that of double-sided concave solids (p. 69 – p. 76).



**75-UNIT STRUCTURE** /p.84

**68-UNIT STRUCTURE** /p.88

**68-UNIT STRUCTURE** /p.82

**90-UNIT STRUCTURE** /p.85

**40-UNIT  
STRUCTURE** /p.82

**36-UNIT STRUCTURE** /p.80

**28-UNIT STRUCTURE** /p.83



Double-sided convex  
hexagonal ring (p. 54)

You can assemble the double-sided hexagonal ring in shapes other than a ball.  
See how many kinds of structures you can assemble using convex units.



(X36)

[Framework Shape]

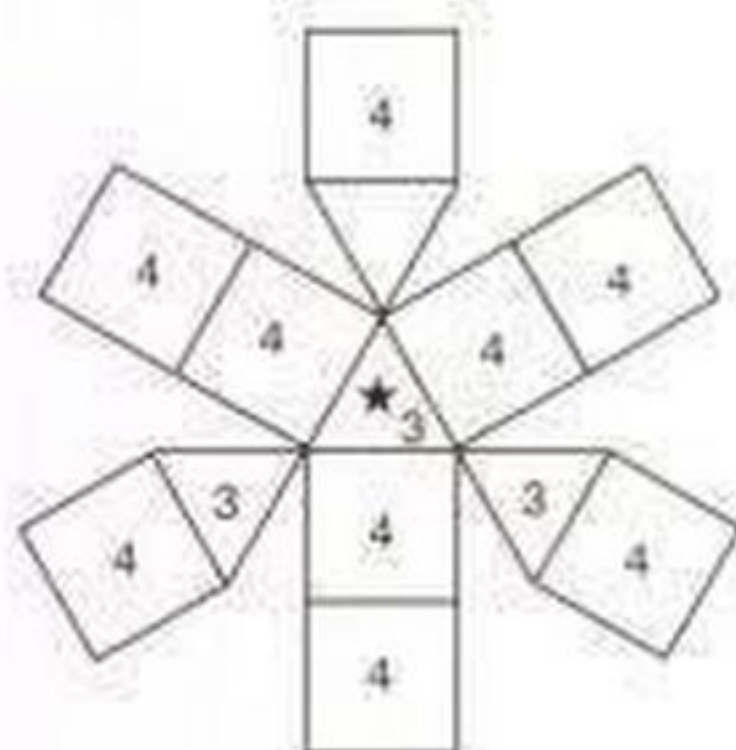
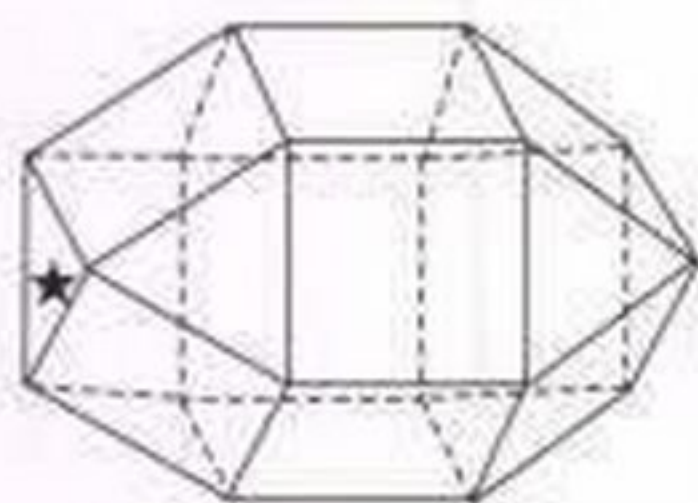

The framework shape viewed lengthwise.  
(Intermediate stage)

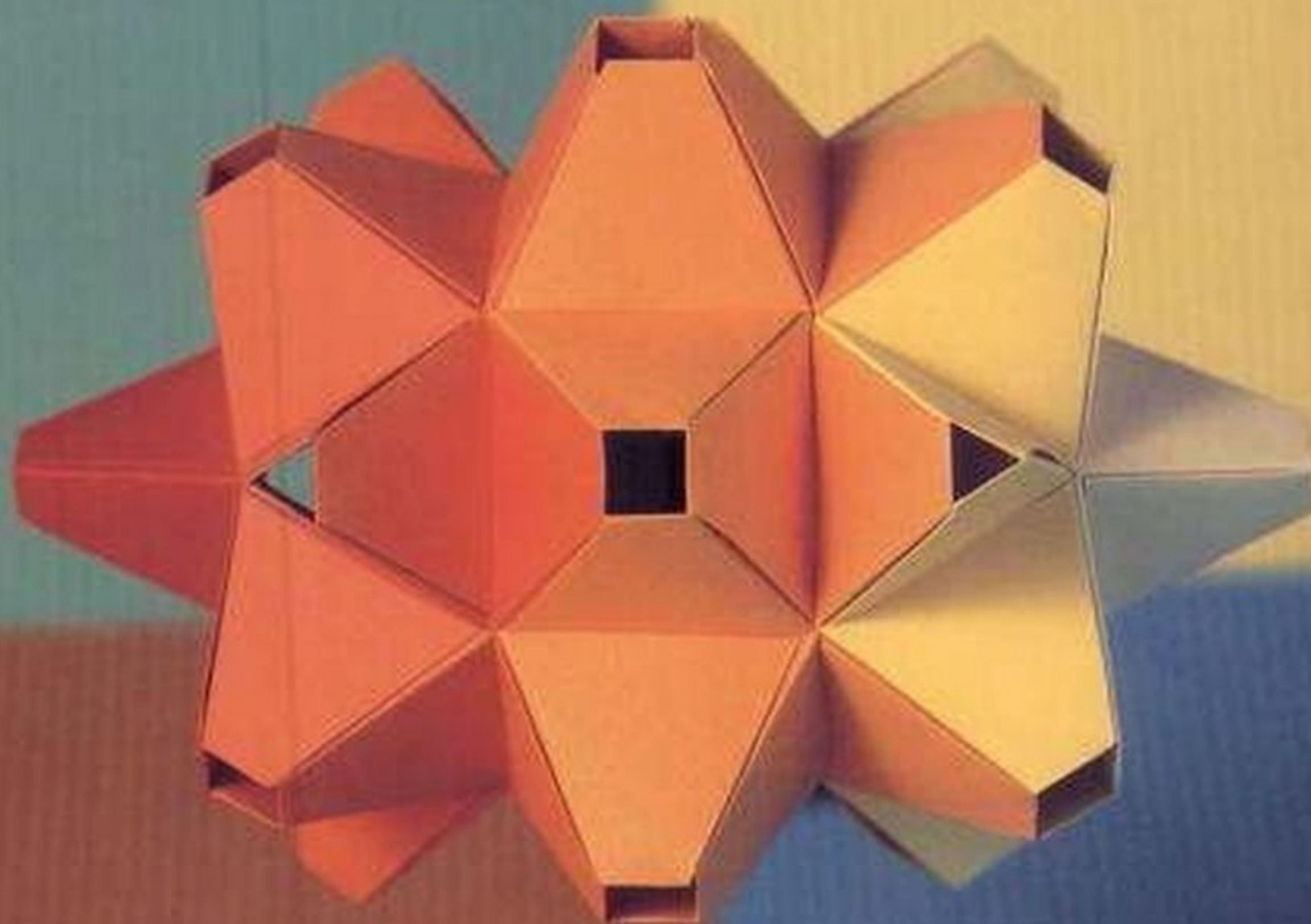
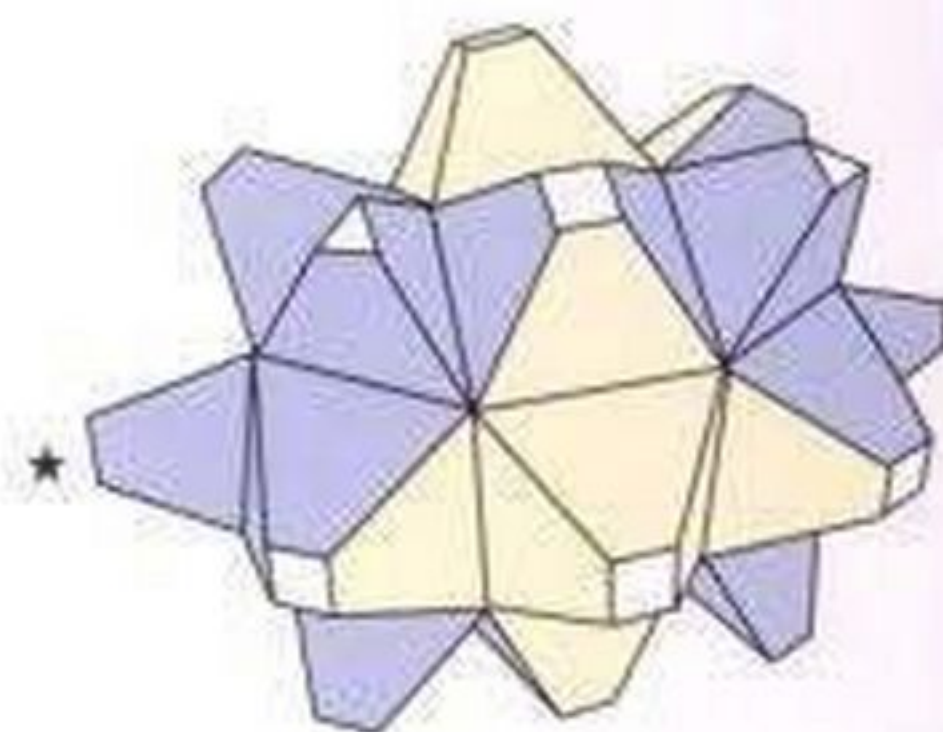



Double-sided convex hexagonal ring (p. 54)



[Framework Shape]

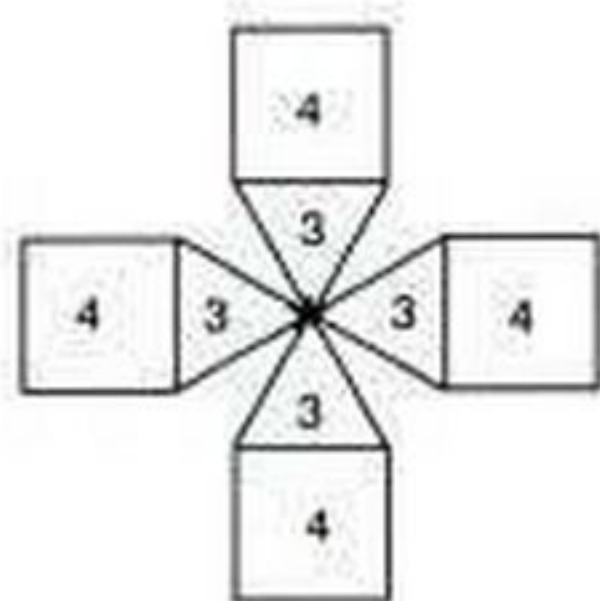
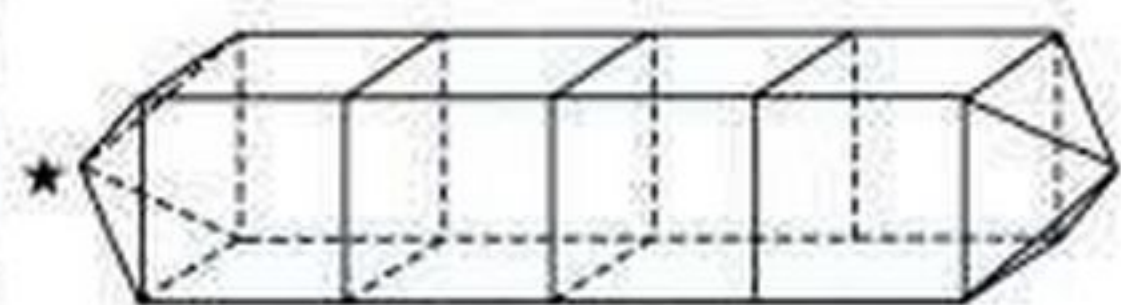

The framework shape viewed lengthwise.  
(Intermediate stage)

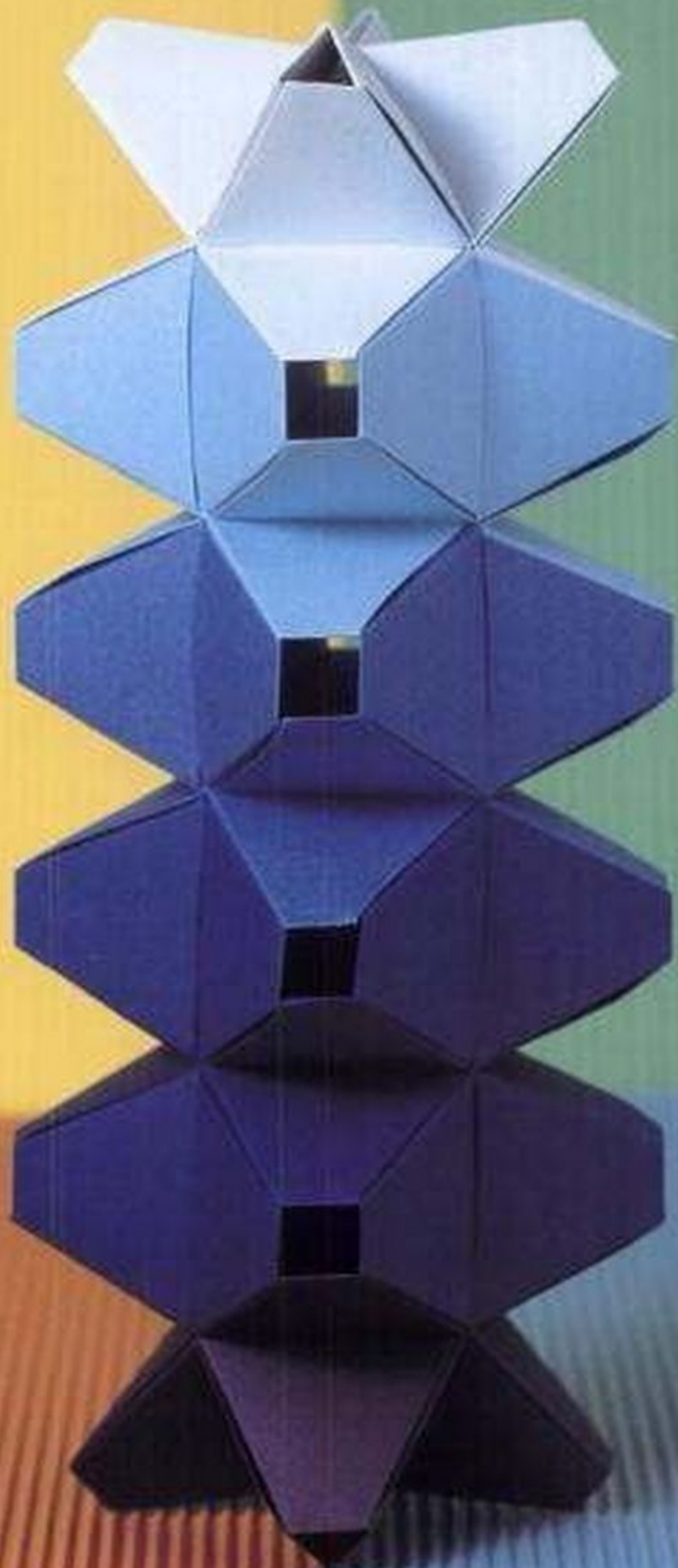
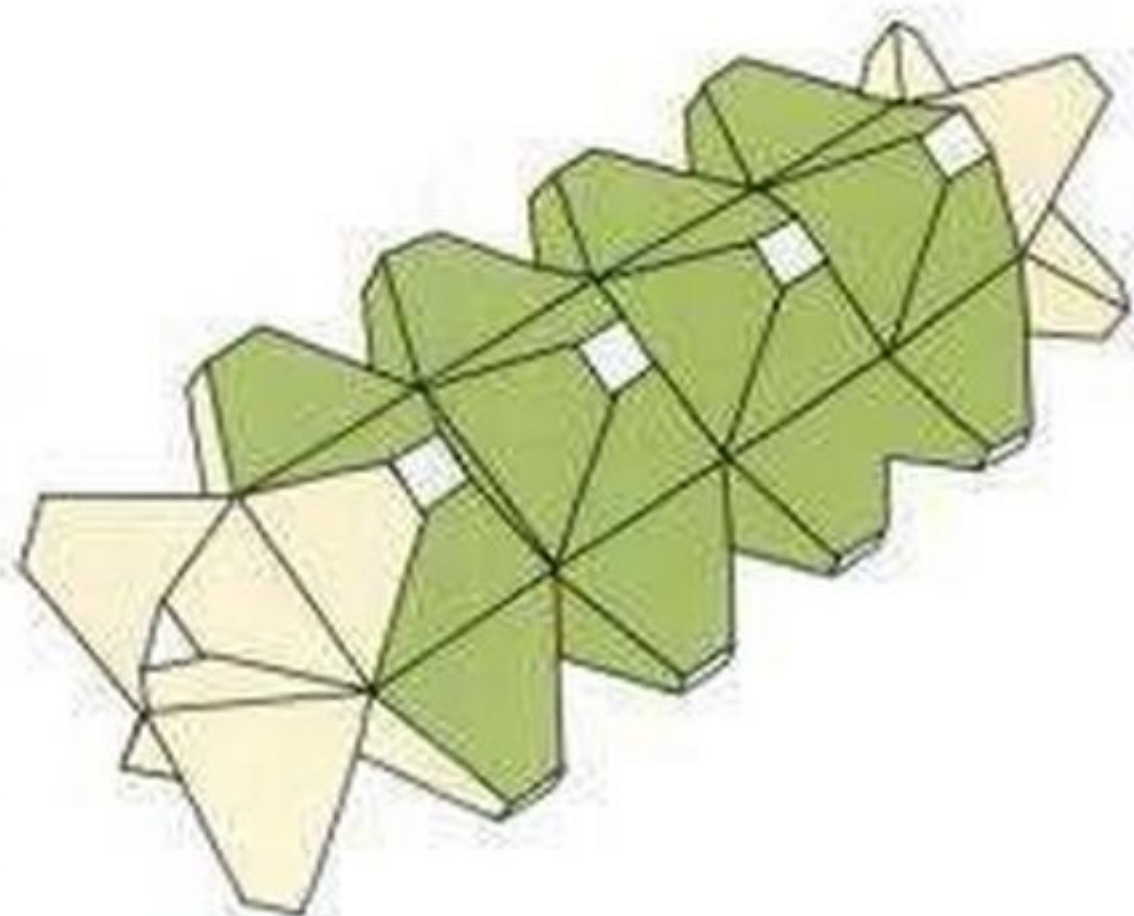



Double-sided concave hexagonal ring (p.68)

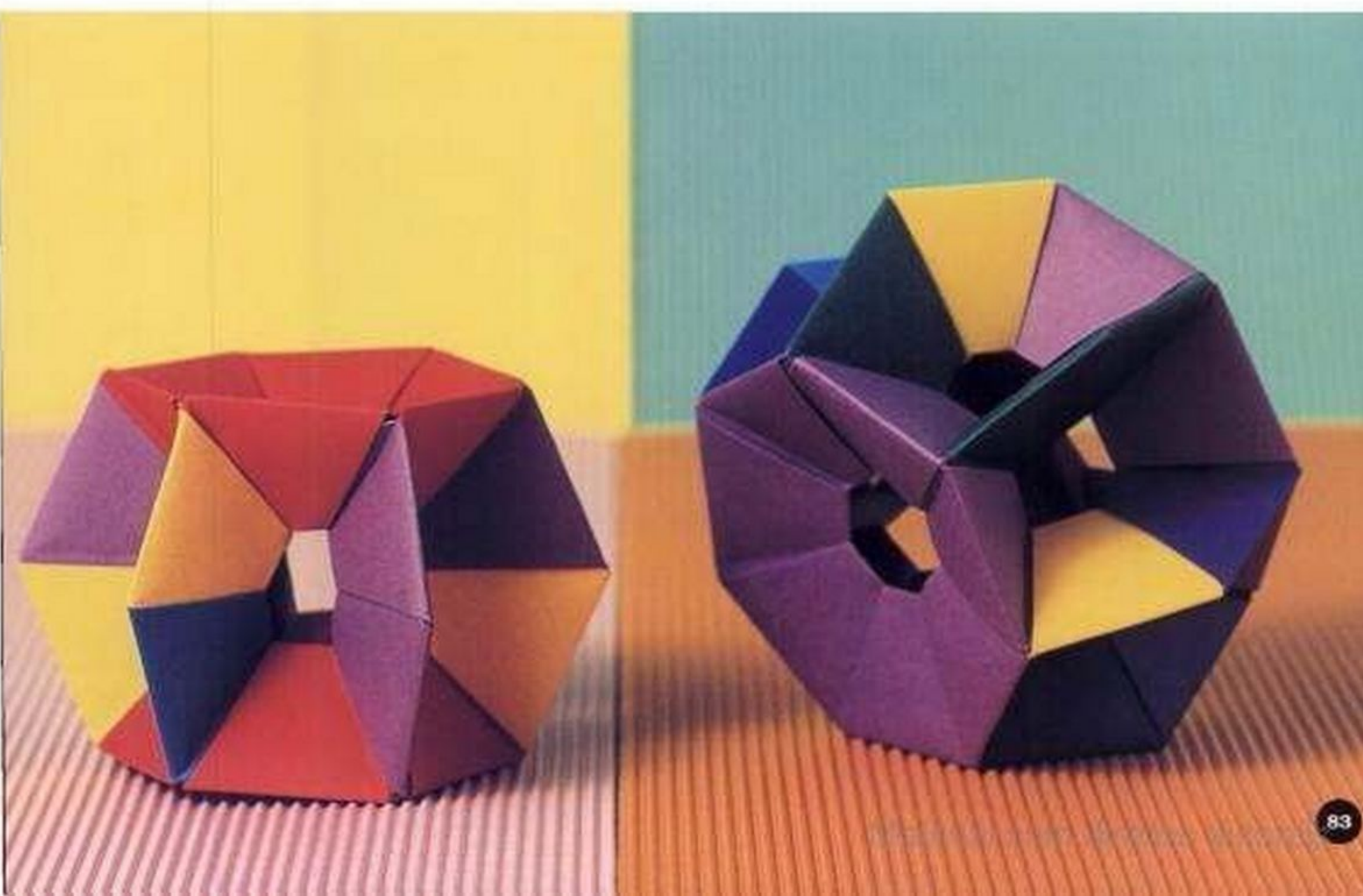
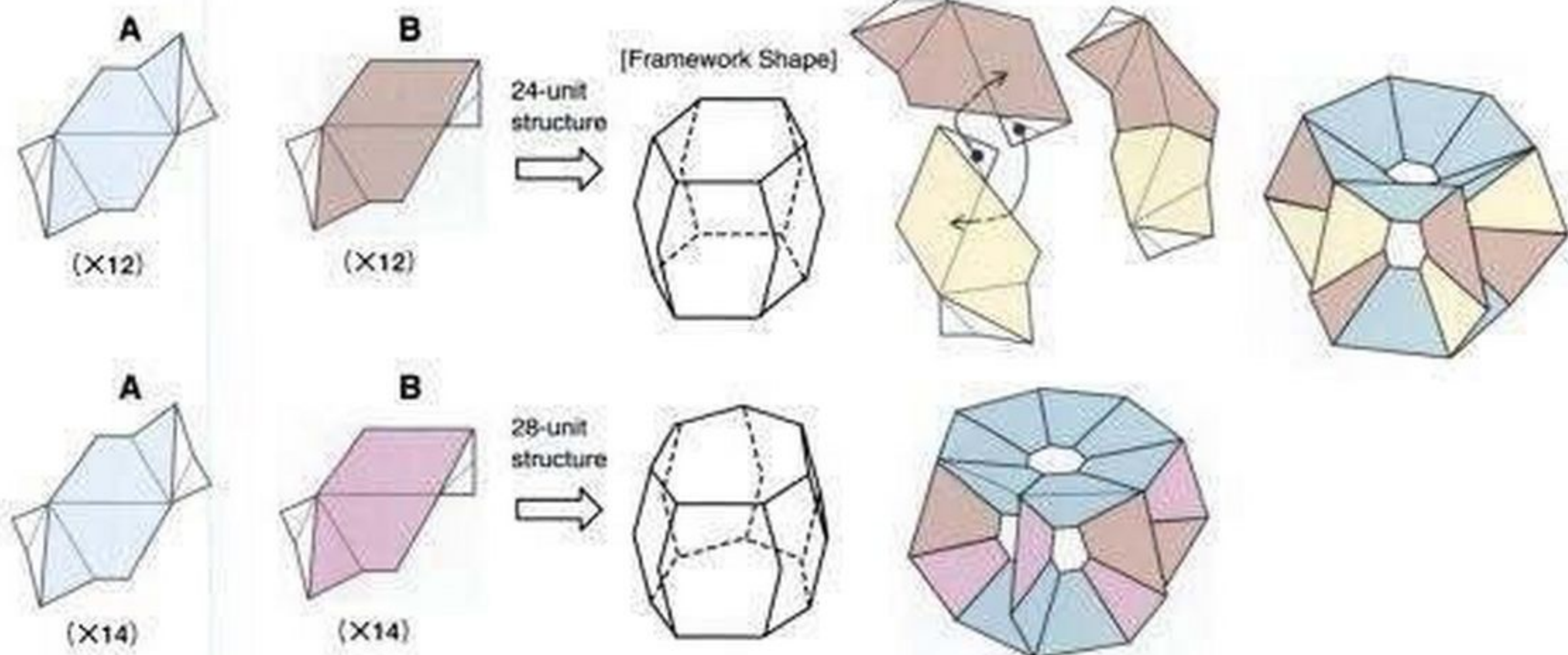



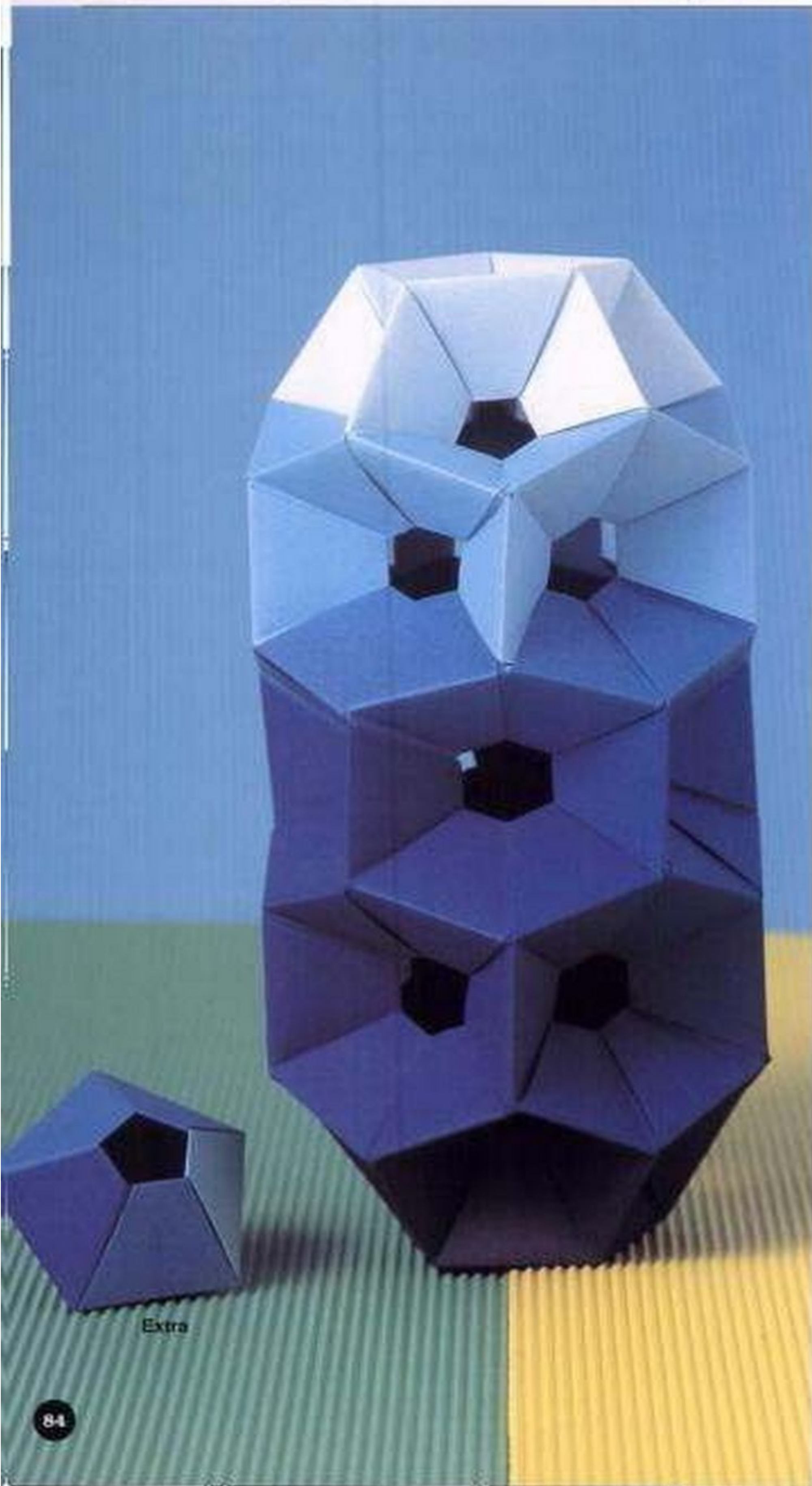

Double-sided concave  
hexagonal ring (p.68)

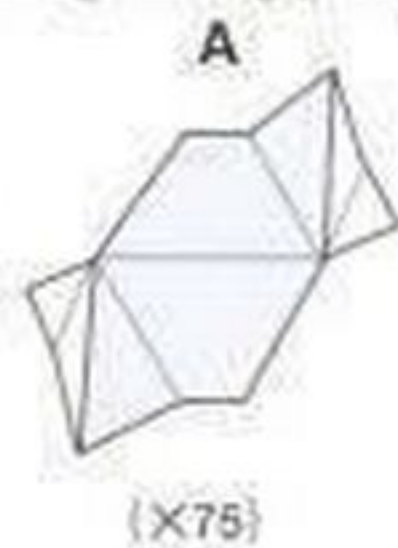

[Framework Shape]

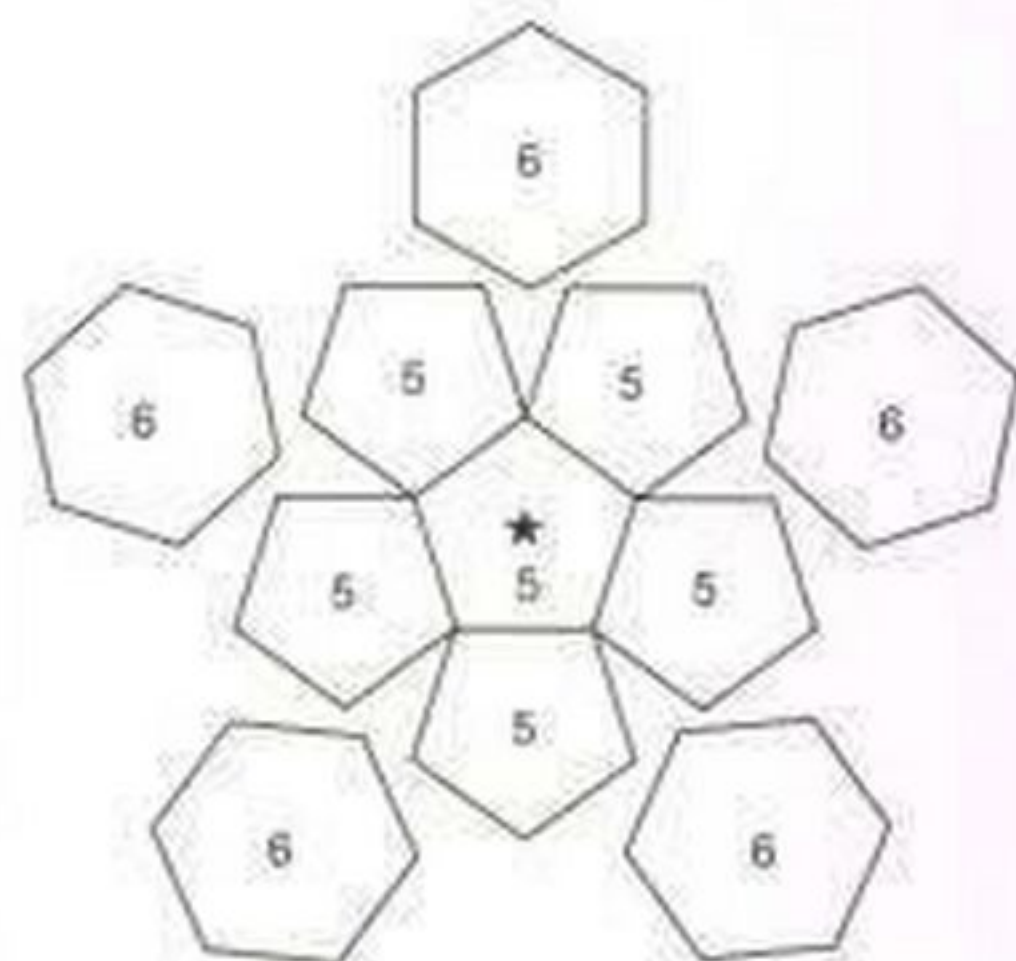
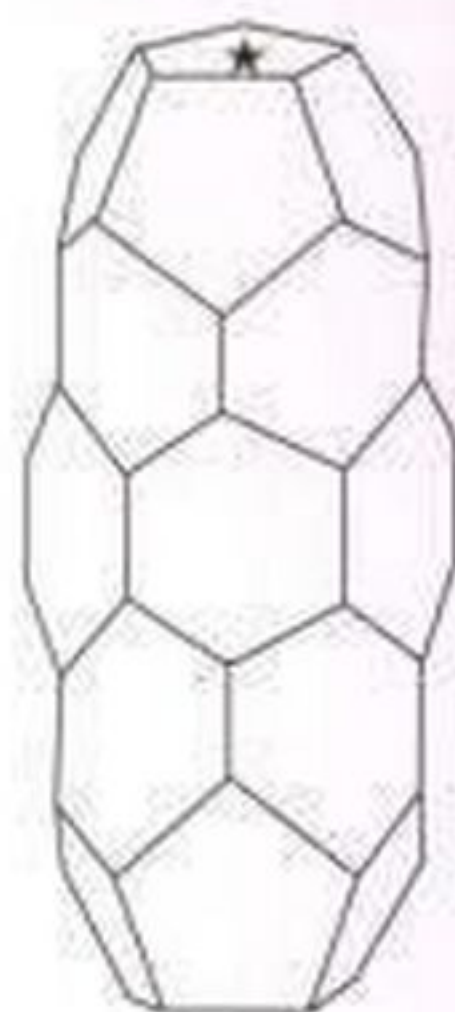

The framework shape viewed lengthwise.  
(Intermediate stage)

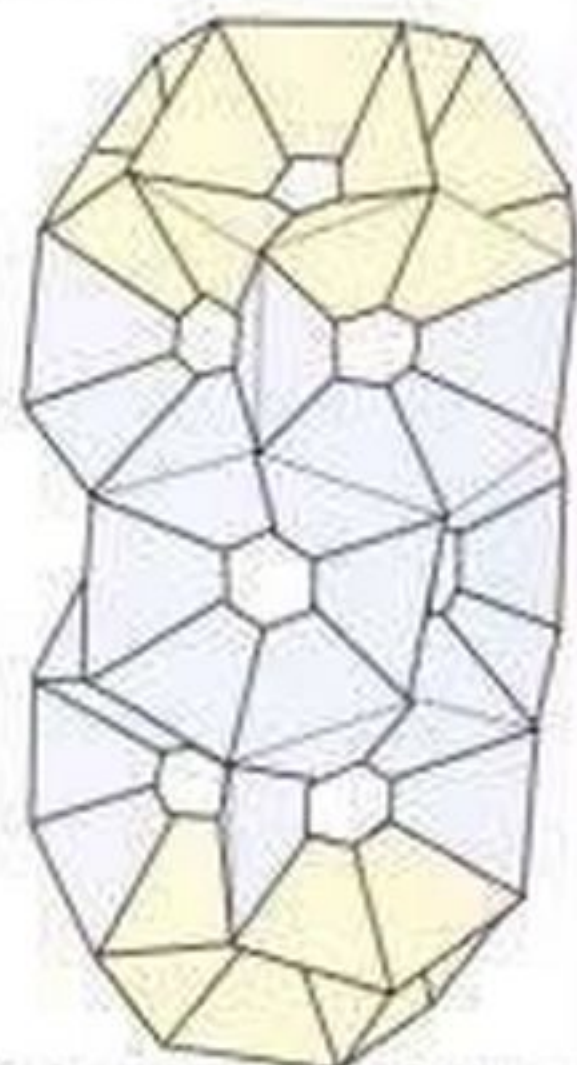

Material com direitos autorais



Double-sided convex hexagonal ring (p.54)

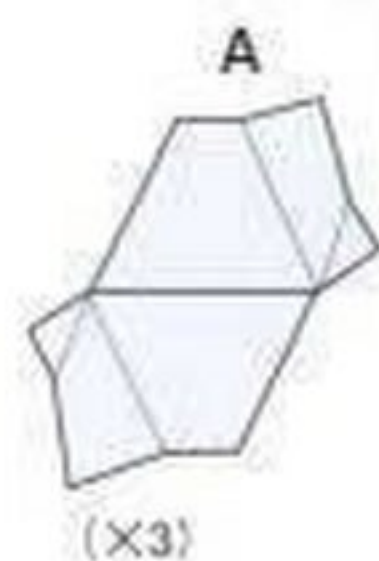

Double-sided concave hexagonal ring (p.68)

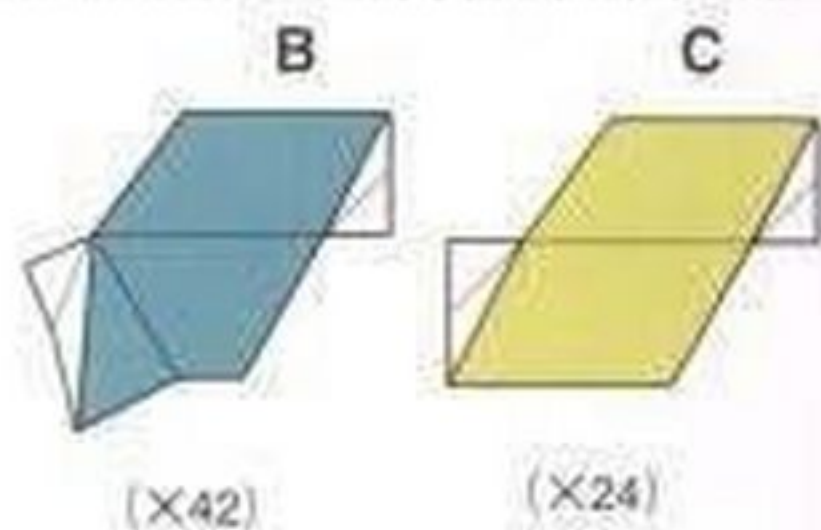

[Core Solid]

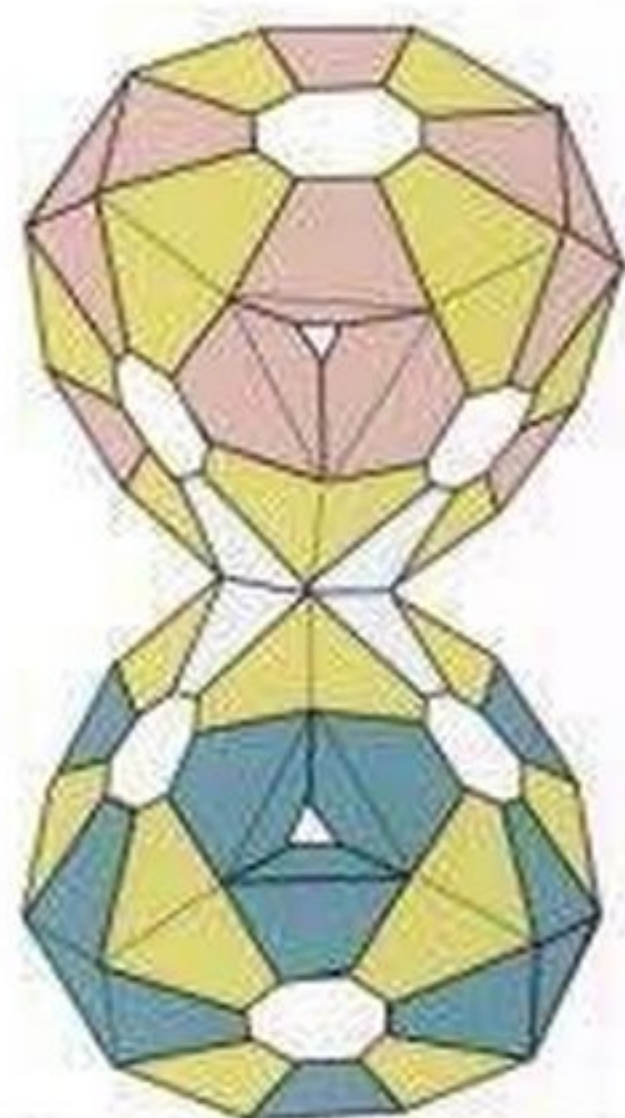
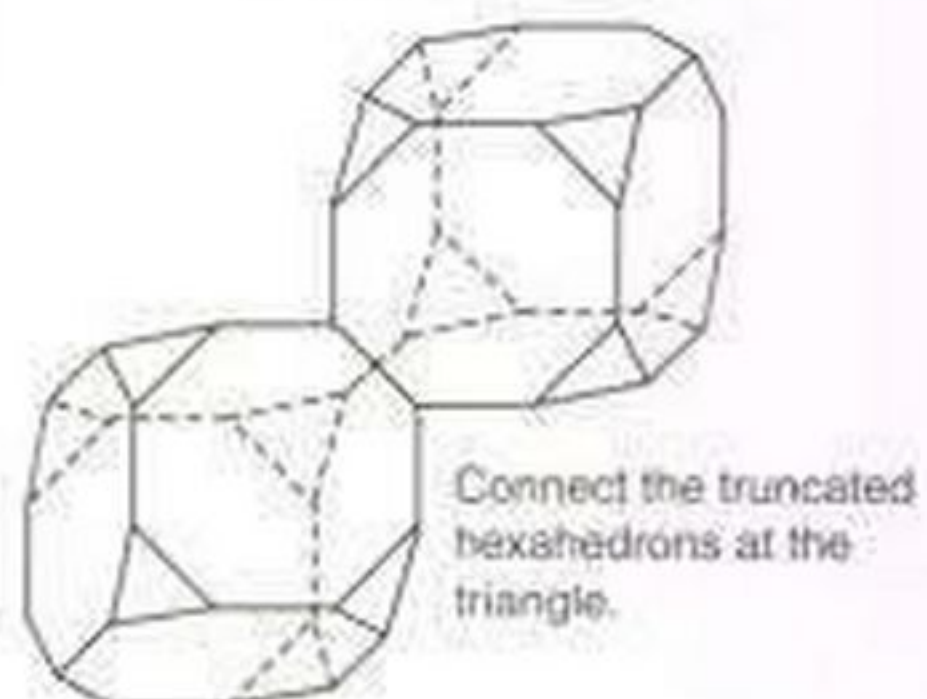



Double-sided convex hexagonal ring (p.54)

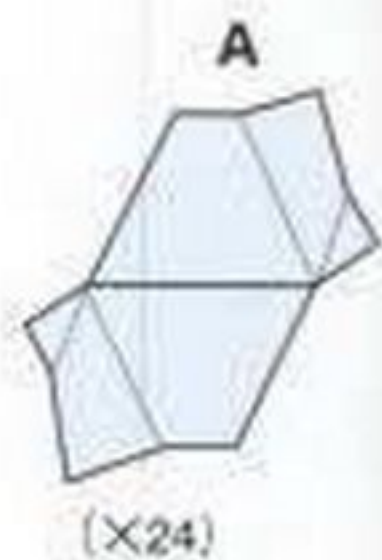

Double-sided concave hexagonal ring (p.68)

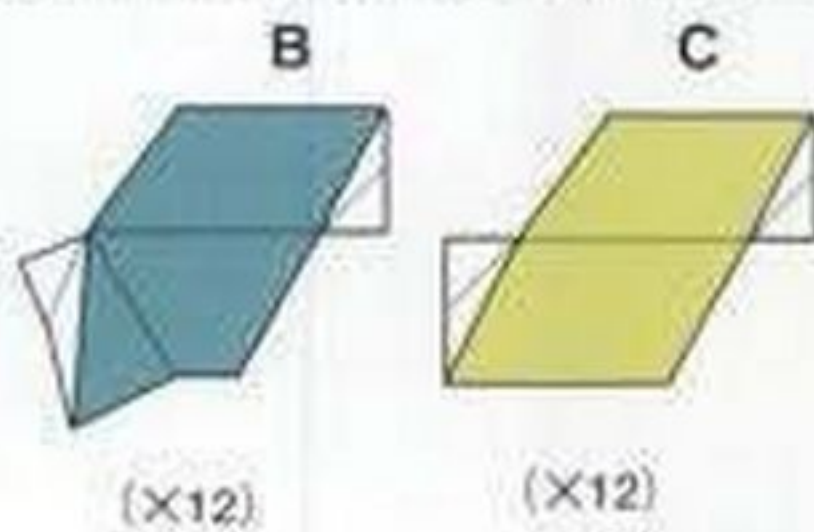

[Core Solid]

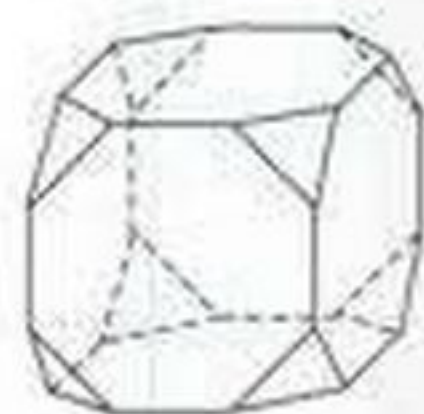

Connect the 3-unit assemblies at the  
triangle of truncated hexahedrons.

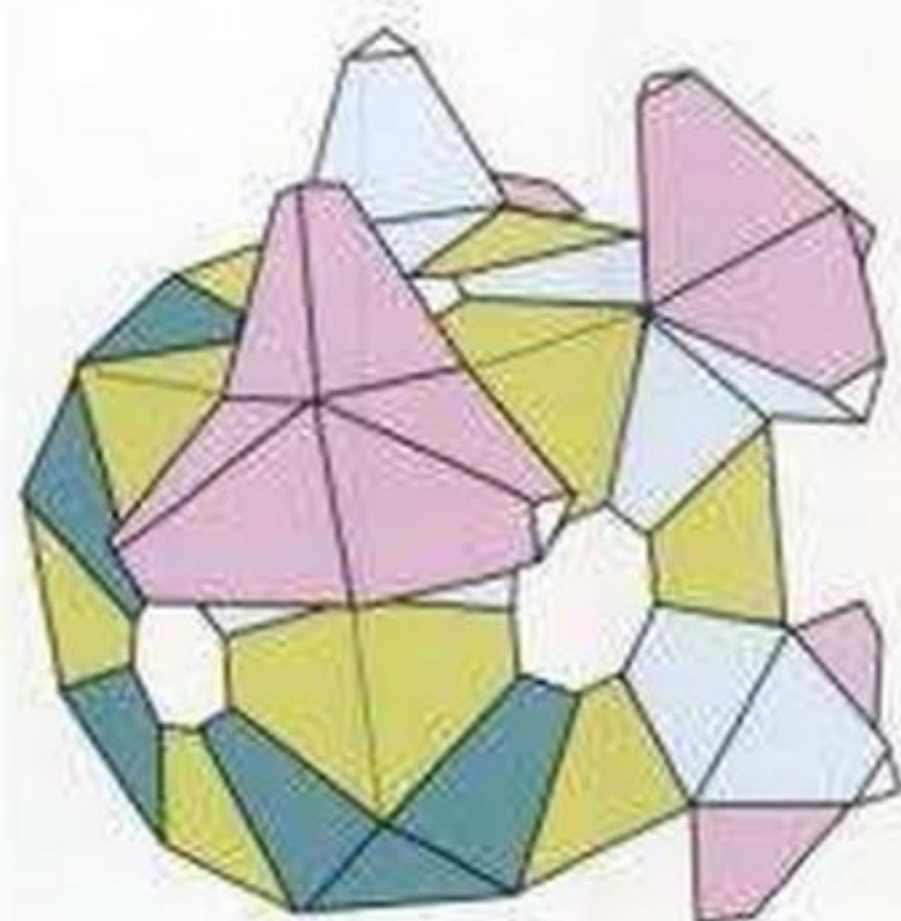



If you use convex units for jointing, you can connect solids made of concave units. Devise your own variations and try to construct different shapes. You can figure out how to make forms other than spherical shapes.

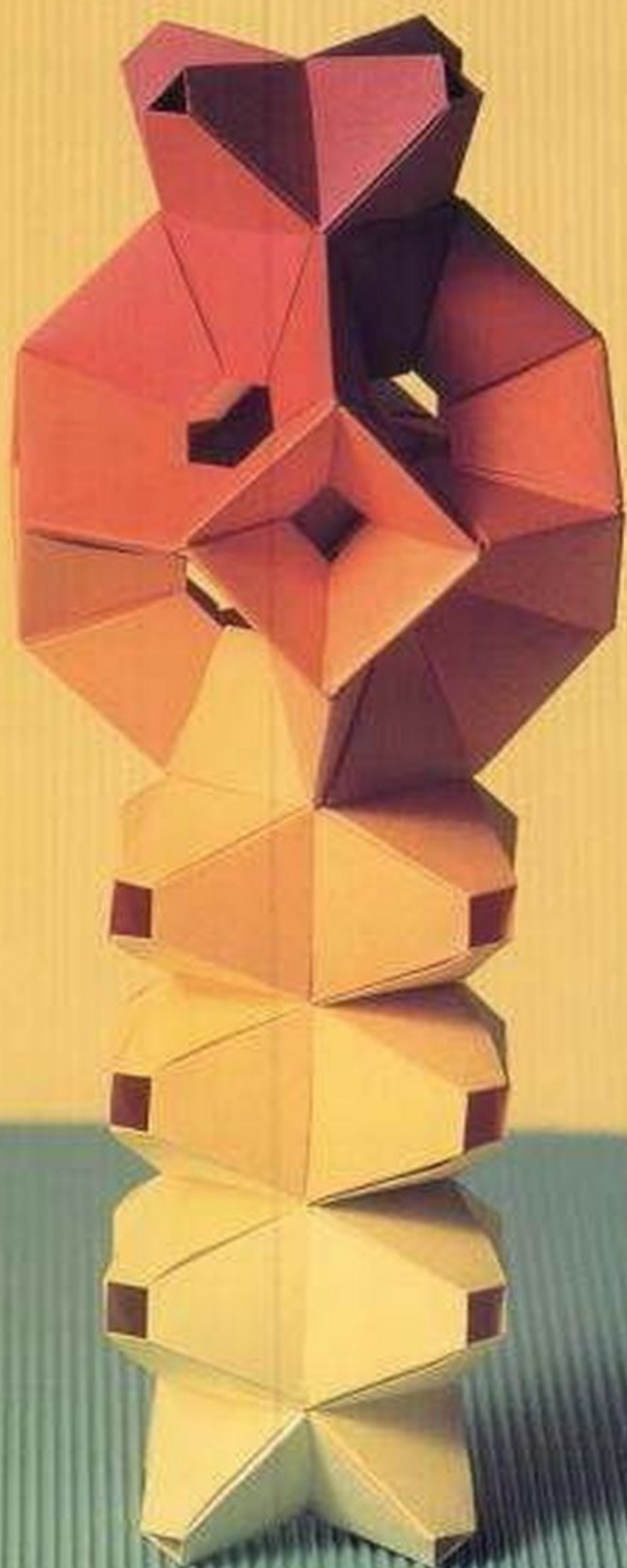

Double-sided convex hexagonal ring (p.54)

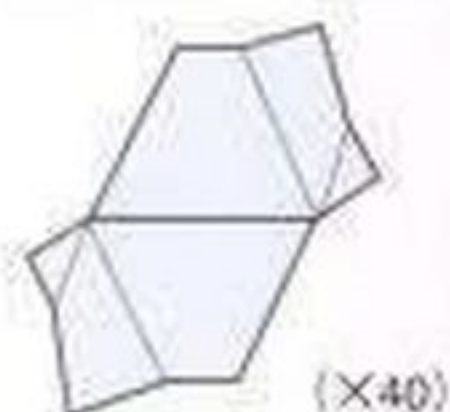

Double-sided concave hexagonal ring (p.68)

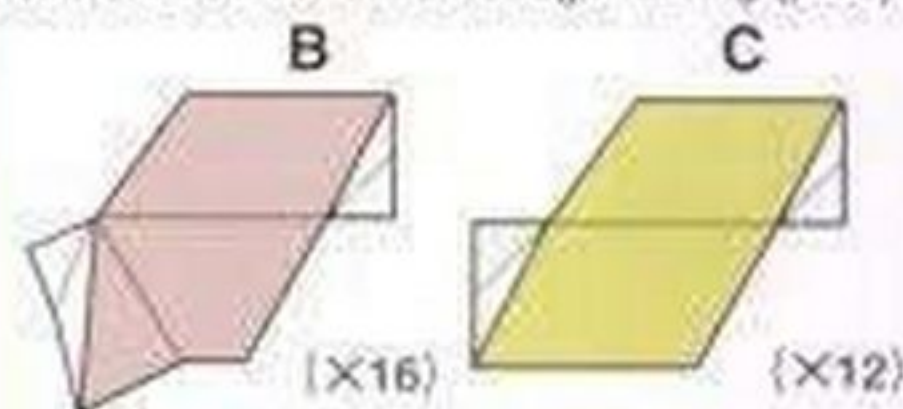

[Core Solid]

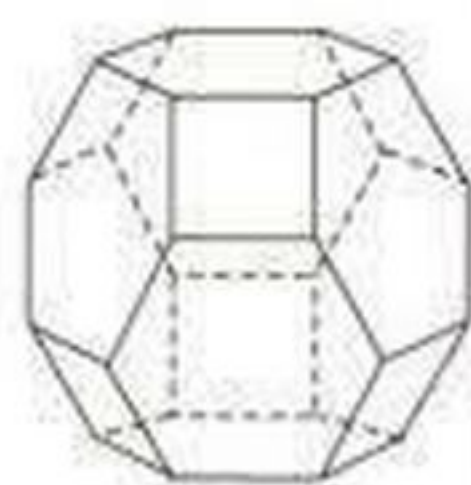

Connect the double-sided convex hexagonal rings to the square.

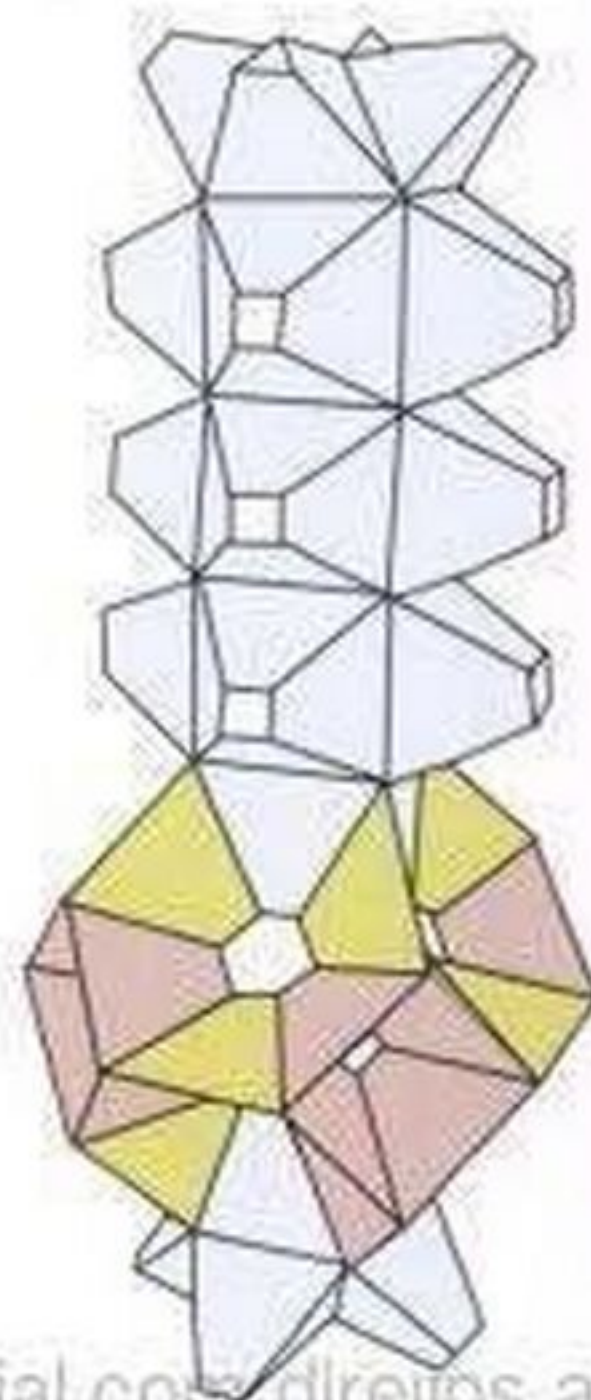



Double-sided convex hexagonal ring (p.54)



(×48)

Double-sided concave hexagonal ring (p.68)

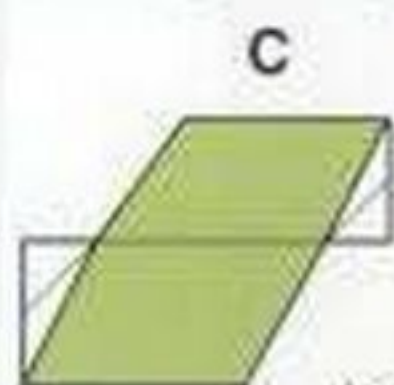

(×12)

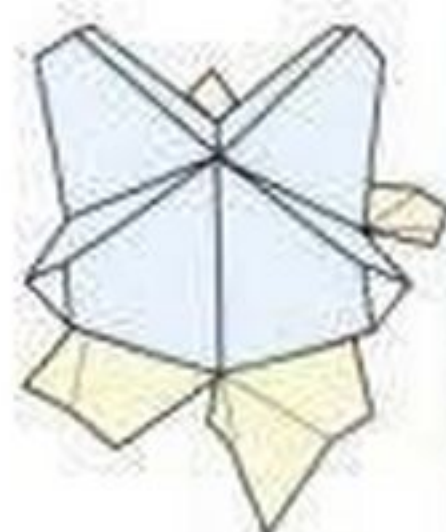

Six-unit structure of double-sided convex hexagonal rings. The bottom is square.



[Core Solid]

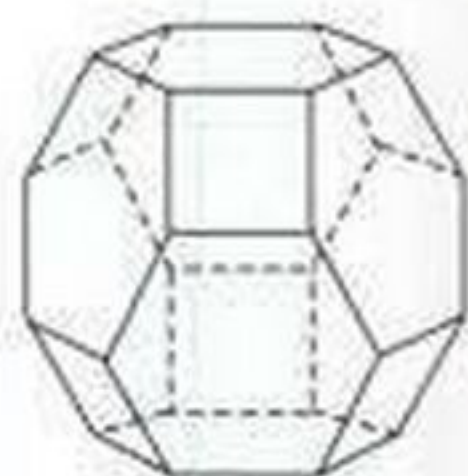

Connect 8-unit assemblies of double-sided convex hexagonal rings at the square.

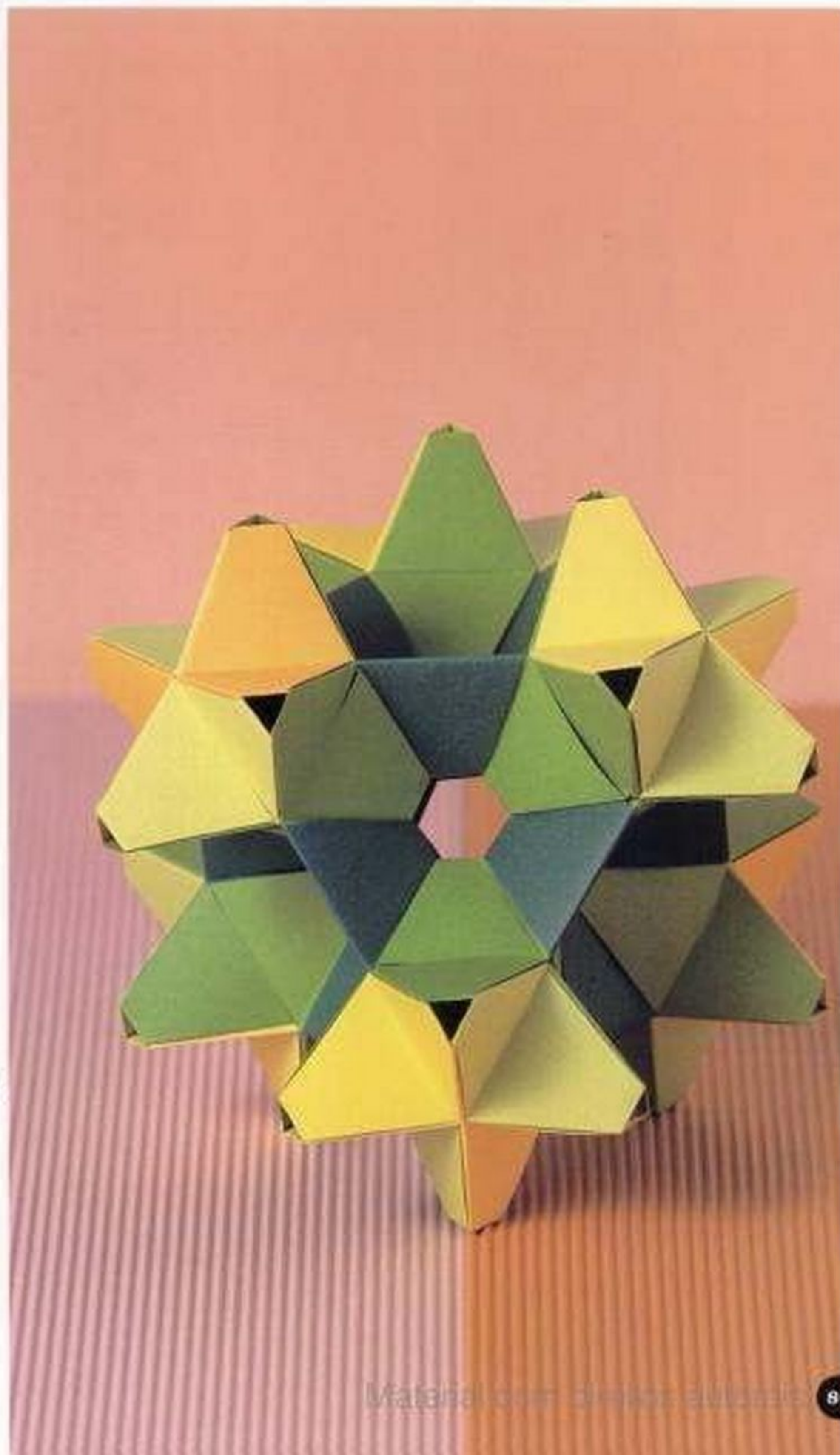
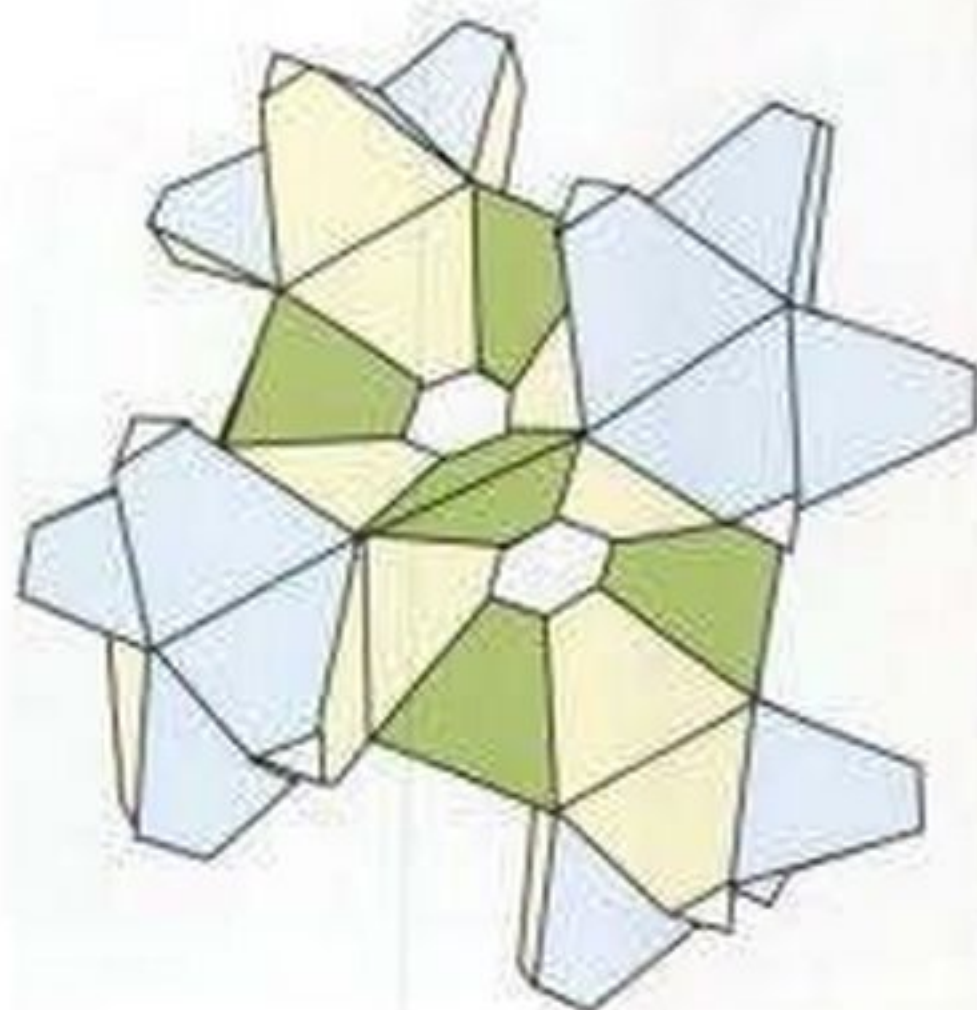



# 9

## DIAGONALLY FOLDED TRIANGULAR-UNIT SOLIDS

This unit is made from rectangular paper, which is made from square paper cut in half, with a basic crease made diagonally. The finished solids are sturdy. Shown here are models with polyhedrons at their core.



**6-UNIT STRUCTURE** /p.94

**30-UNIT STRUCTURE** /p.95

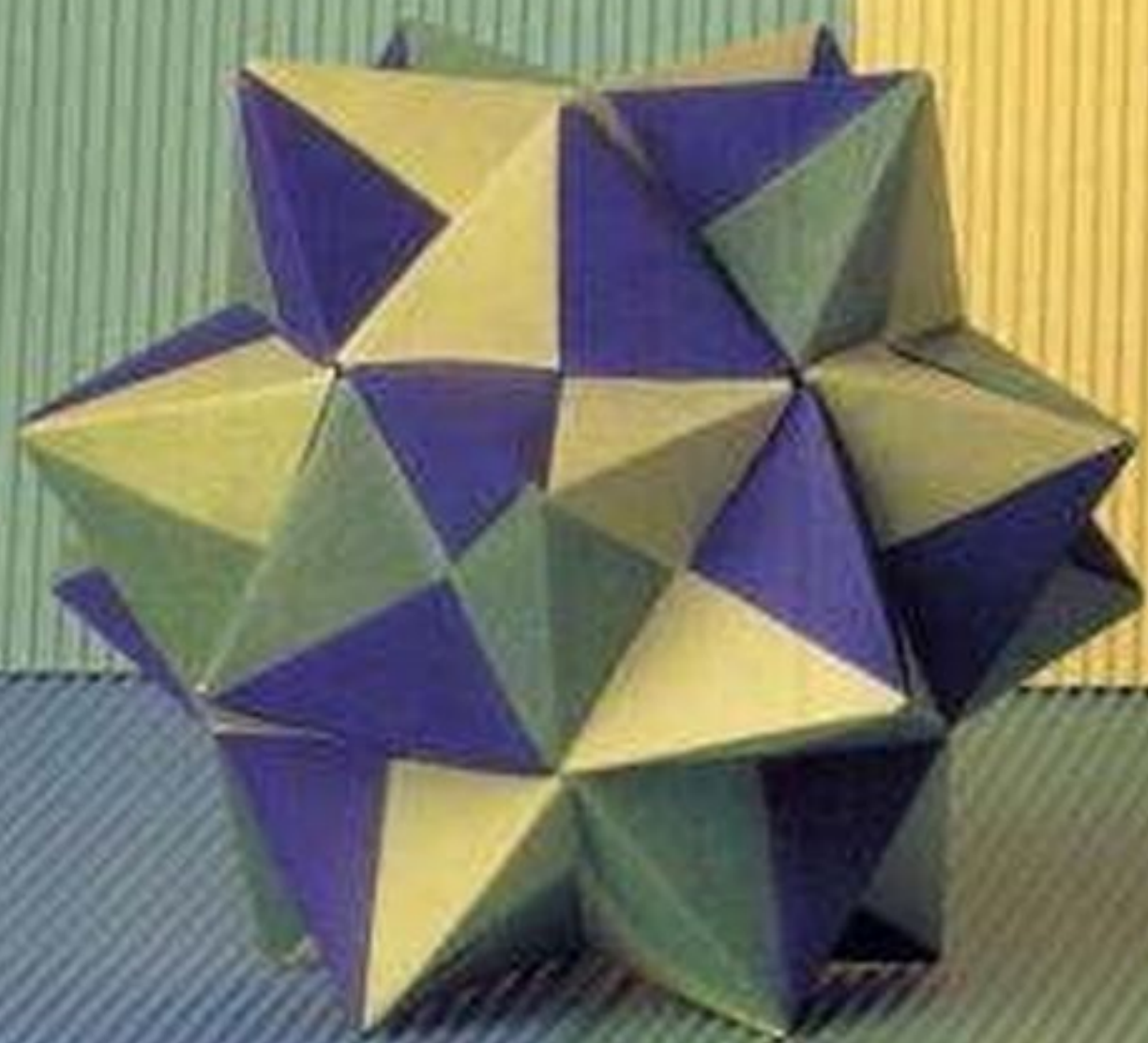

**24-UNIT STRUCTURE** /p.96

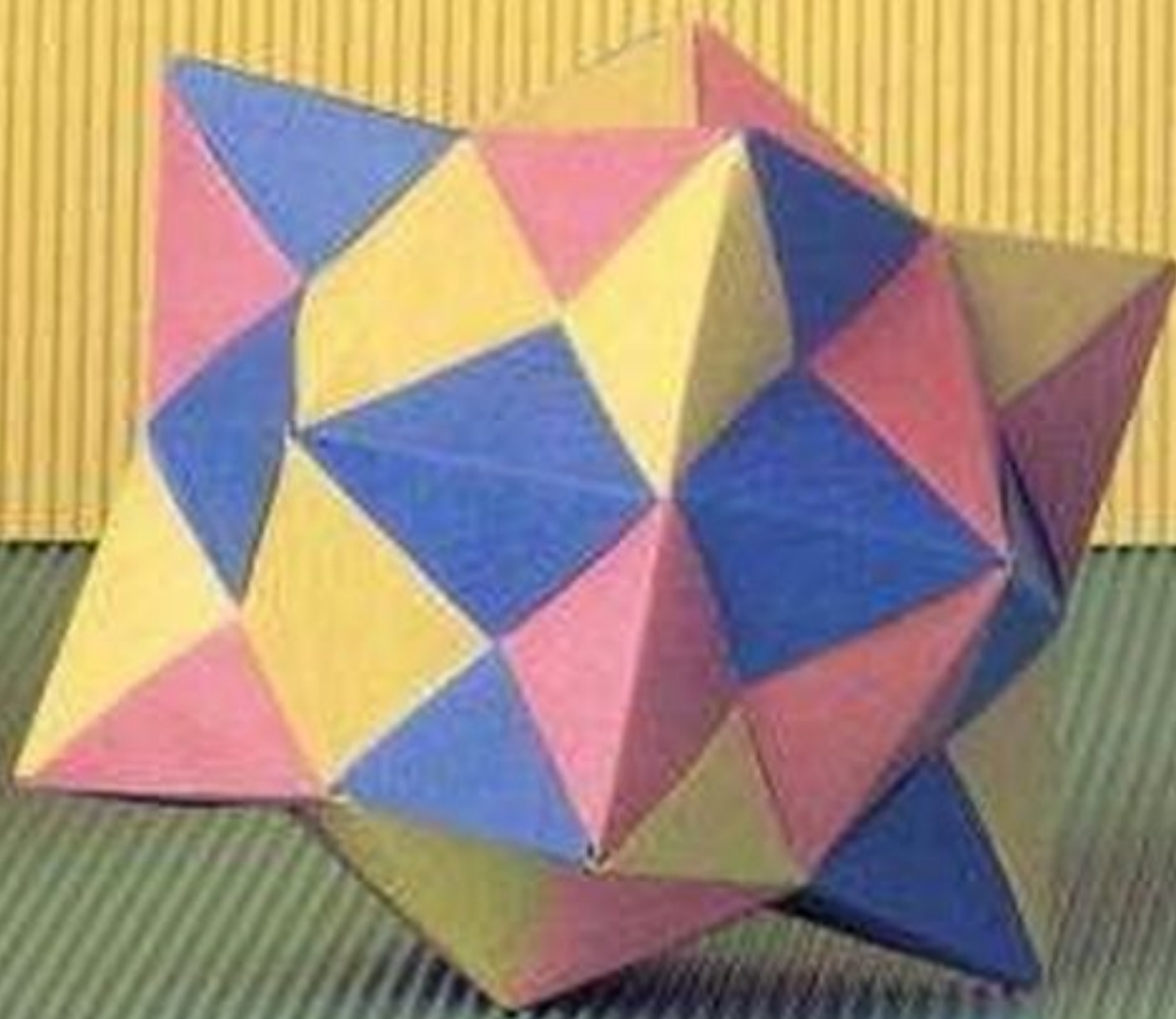





**12-UNIT STRUCTURE** /p.94

**60-UNIT STRUCTURE** /p.98

**48-UNIT STRUCTURE** /p.97

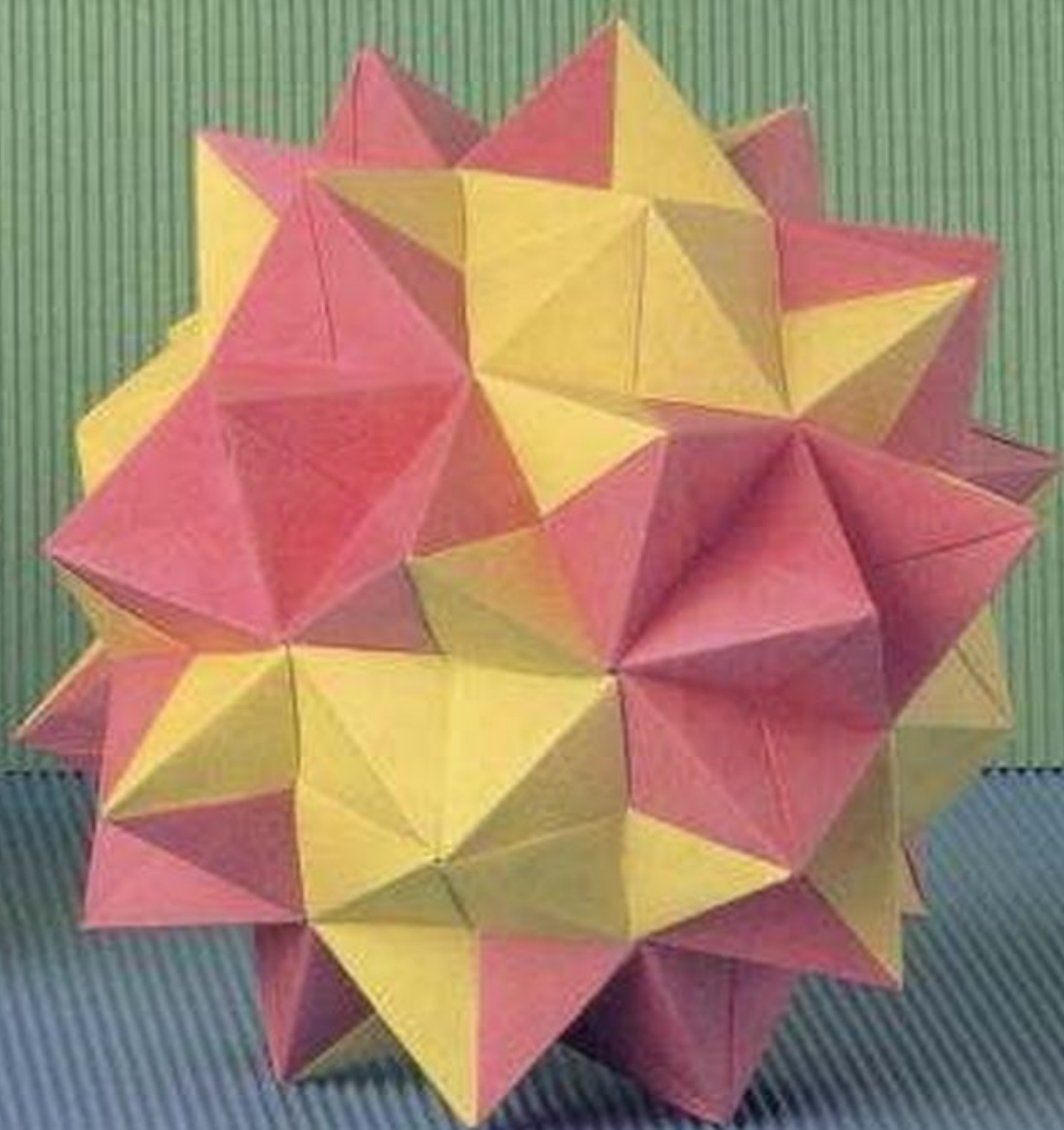
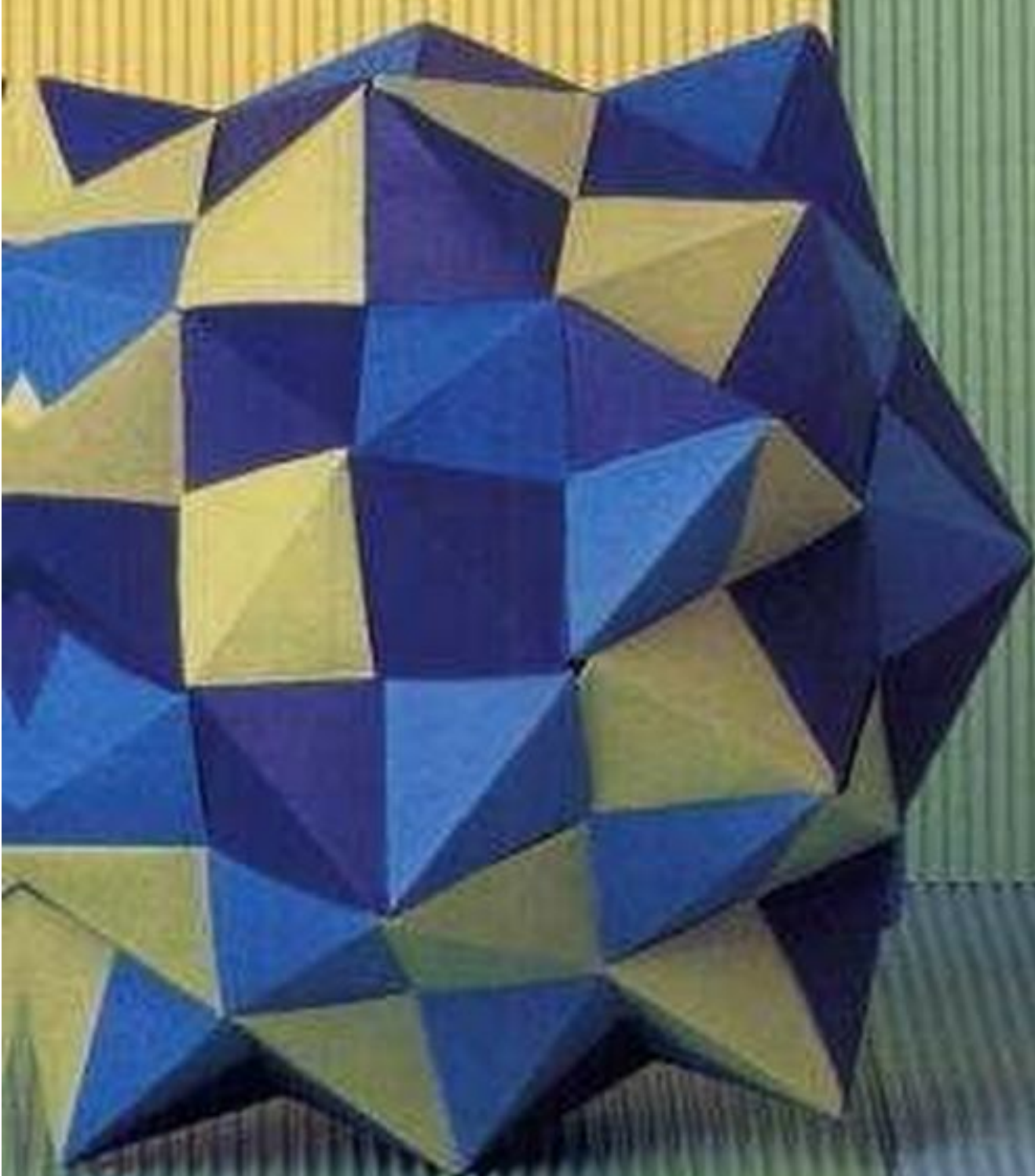



# DIAGONALLY FOLDED TRIANGULAR UNIT

level ★★ 12cm × 6cm

The hooks on the unit make the solid as sturdy as the double-sided hexagonal ring. It is easier to fold than you might think.

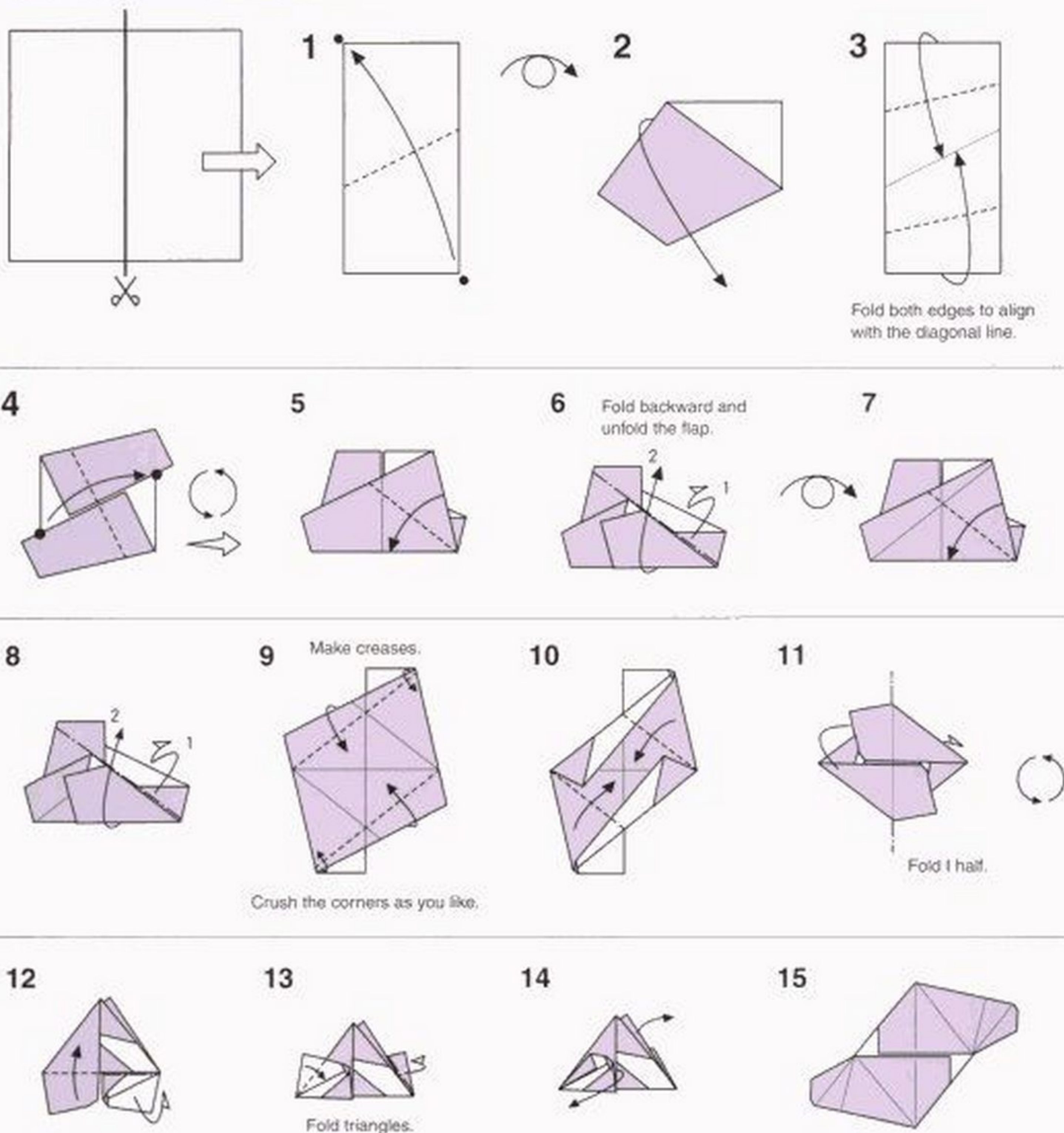



**HINT ON ASSEMBLY 1**

Insert the shaded part deep into the slit of the other unit. The tip works as a hook and makes the structure sturdy.

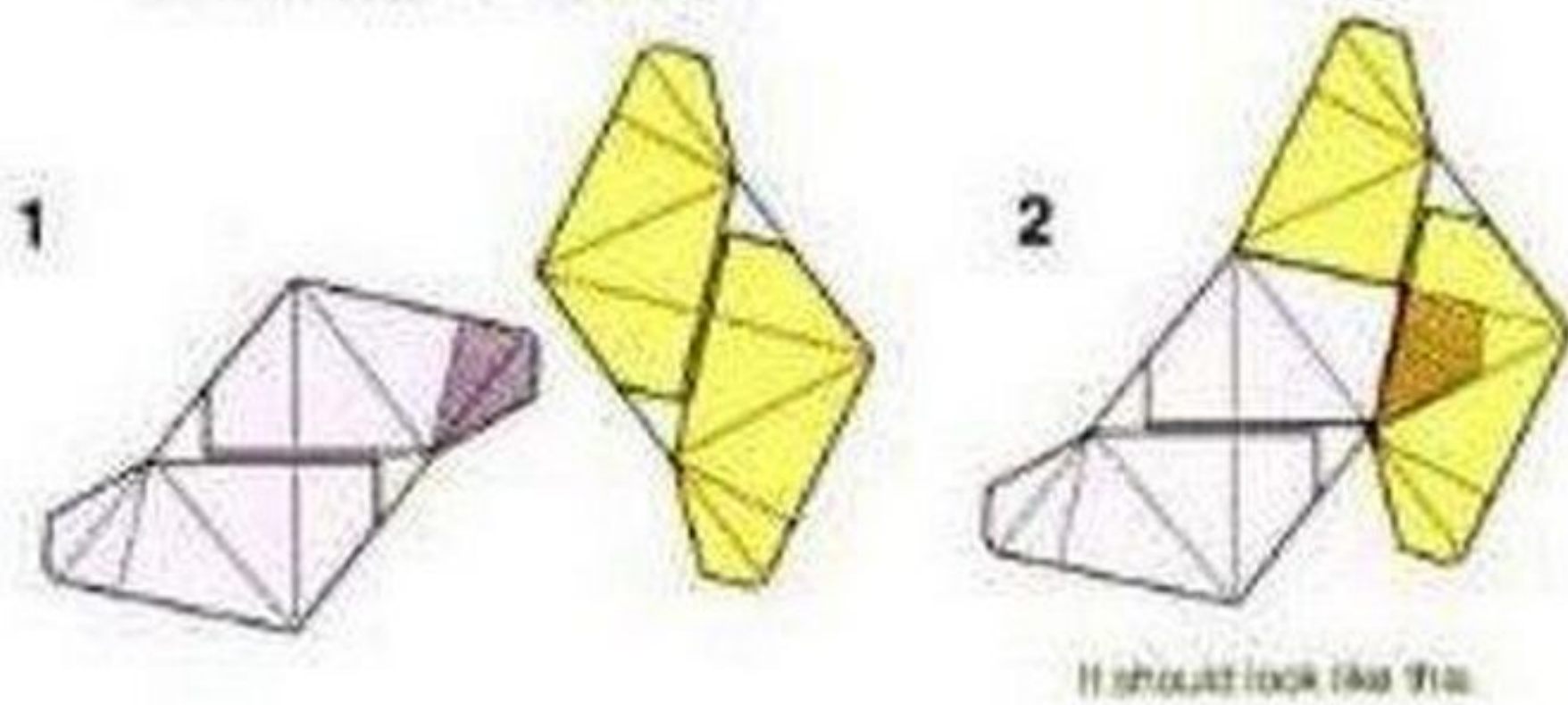

3-unit structure

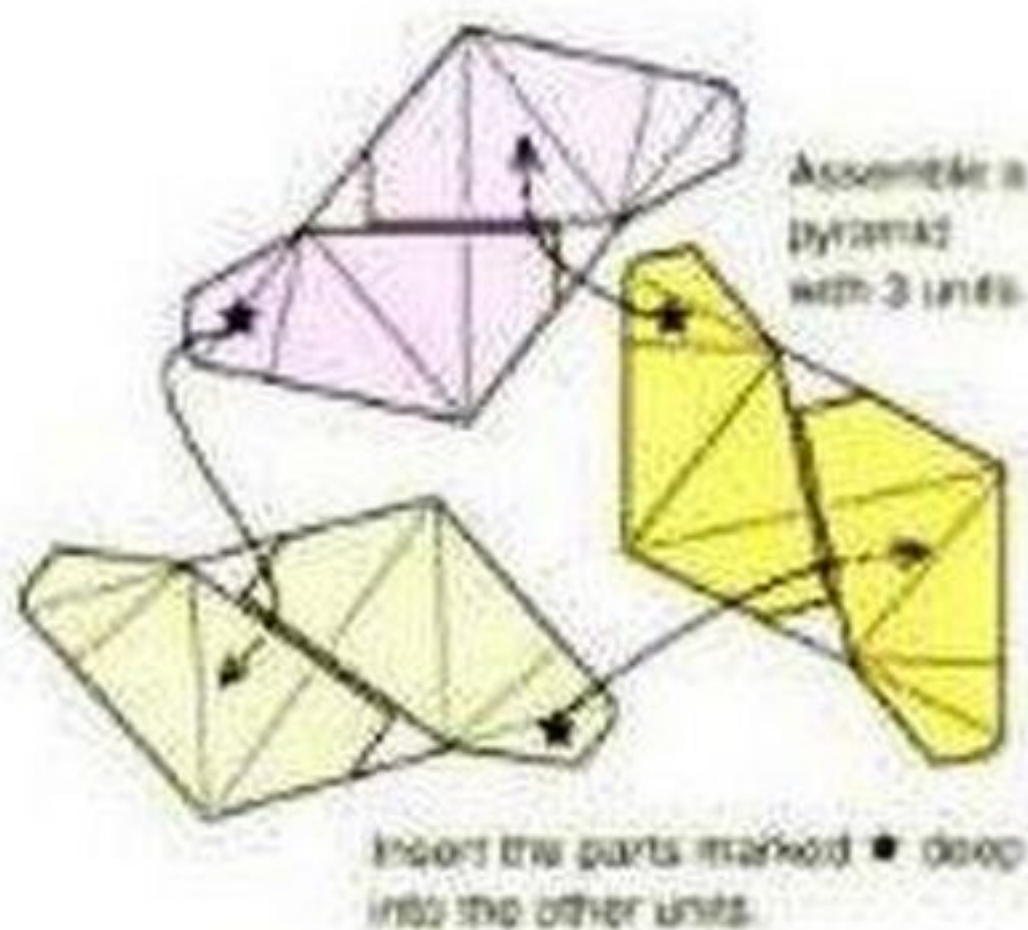

4-unit structure

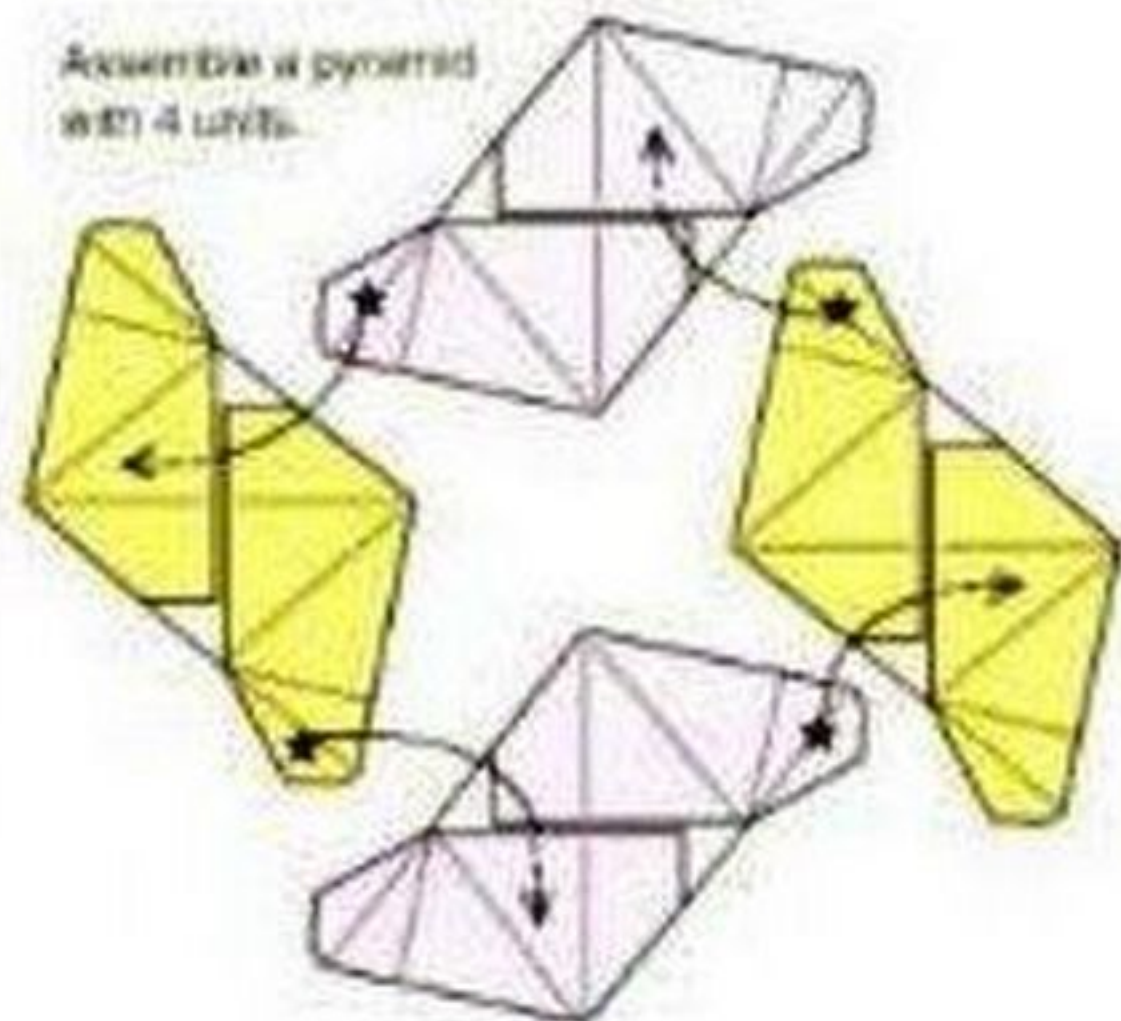

**HINT ON ASSEMBLY 2**

The bottom of each element is a triangle or a square, and each pyramid stands on it. This element lets you assemble a variety of solids. The double-sided convex hexagonal ring (p. 54) had a window on top, but these pyramids have no windows. The assembly method is the same as that of the double-sided convex hexagonal ring, but the slope of the top triangle is so gentle that you can assemble five-sided or six-sided pyramids.

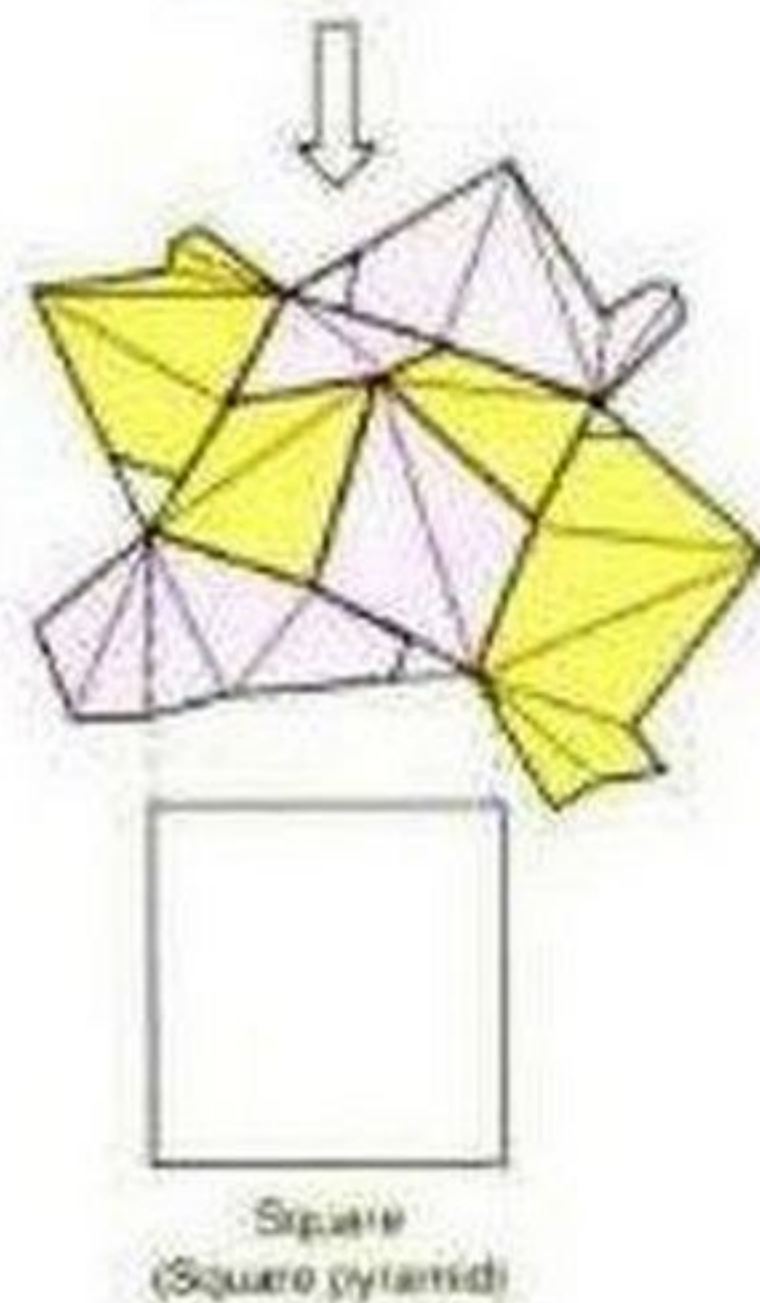
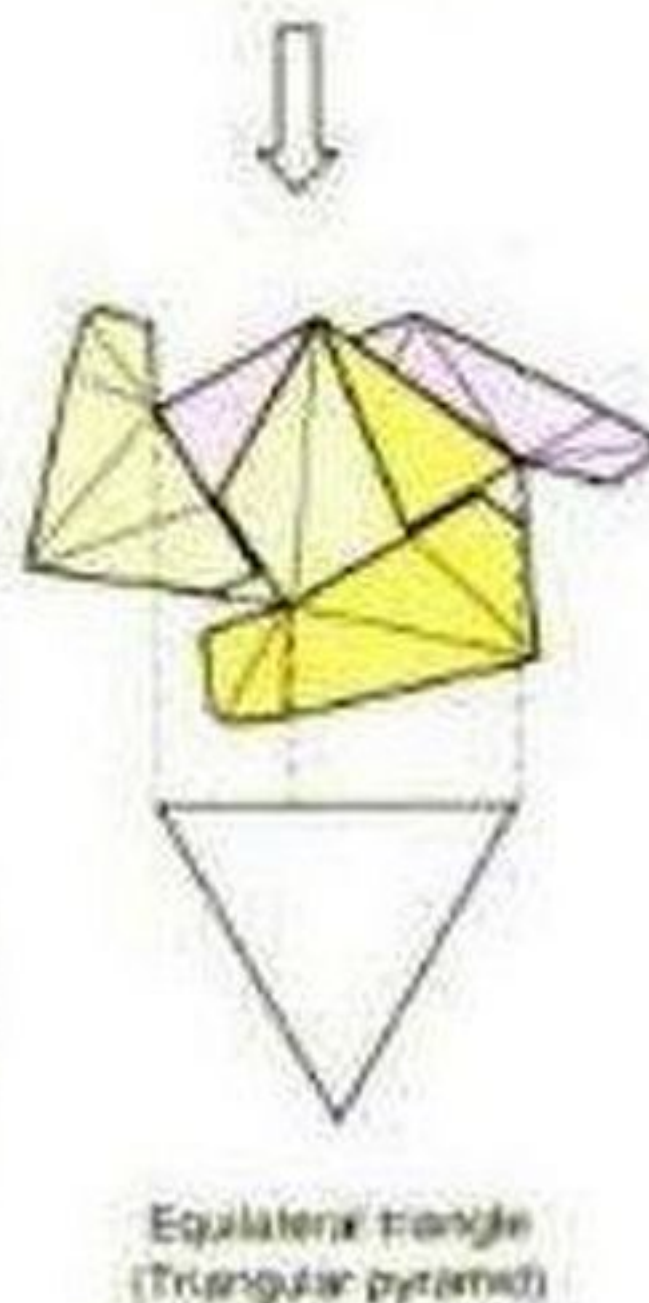



Triangle Unit (p. 82)

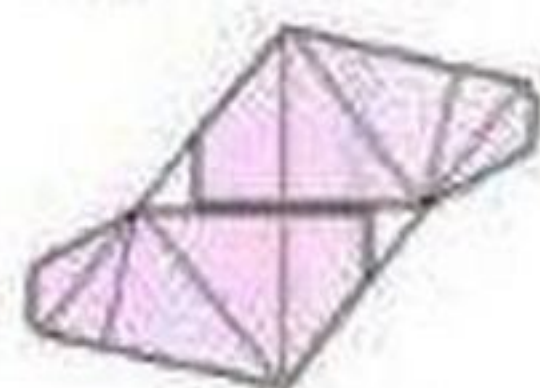

(X6)

Begin with a 3-unit structure.

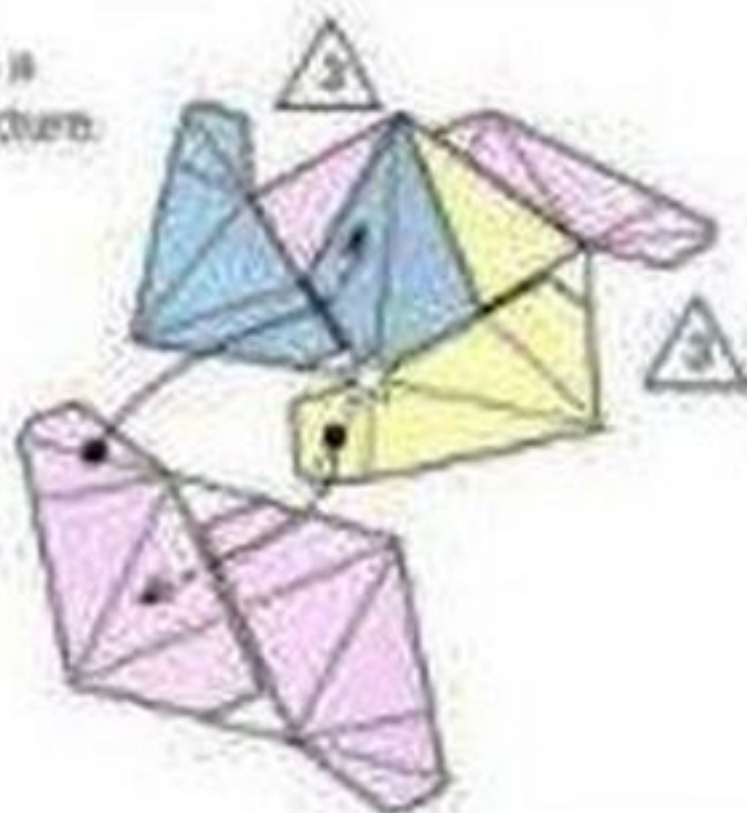

Regular Tetrahedron Star

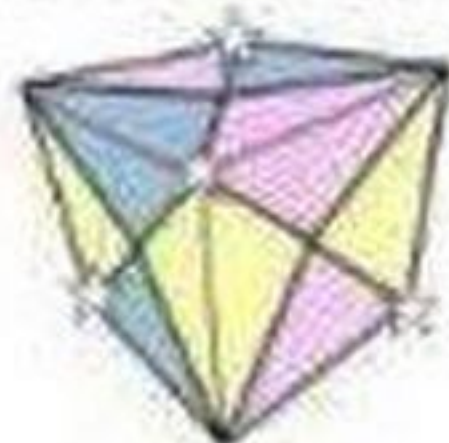

Three triangular pyramids join at the star.



△ X 4

Triangle Unit (p. 82)

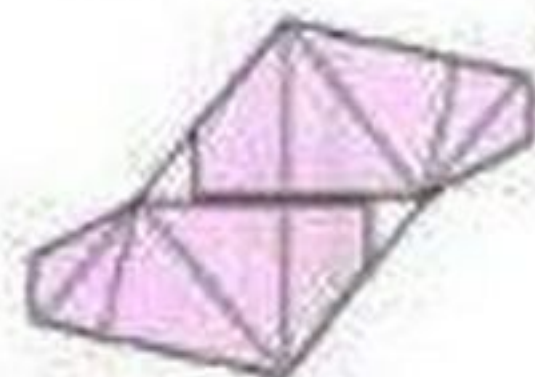

(X12)

Begin with a 3-unit structure.

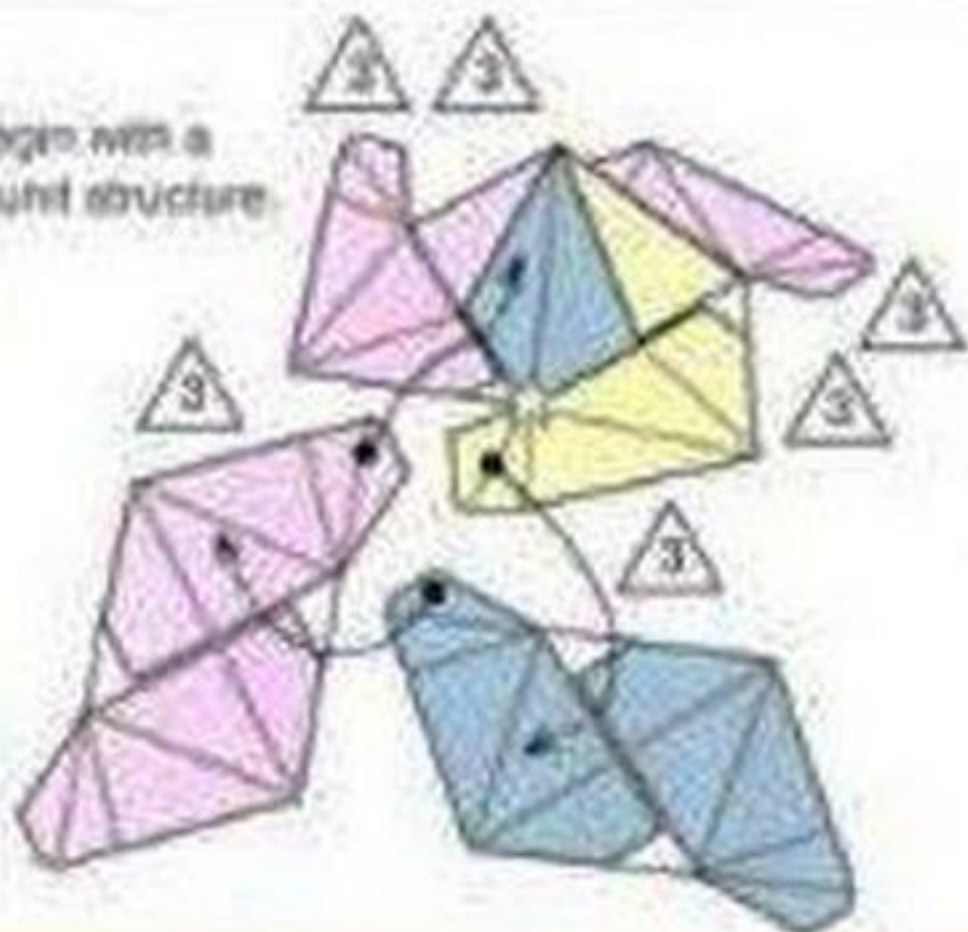

Regular Octahedron Star

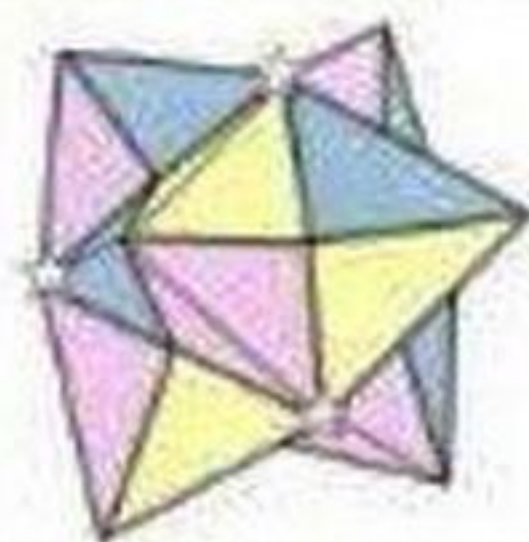

Four triangular pyramids join at the star.

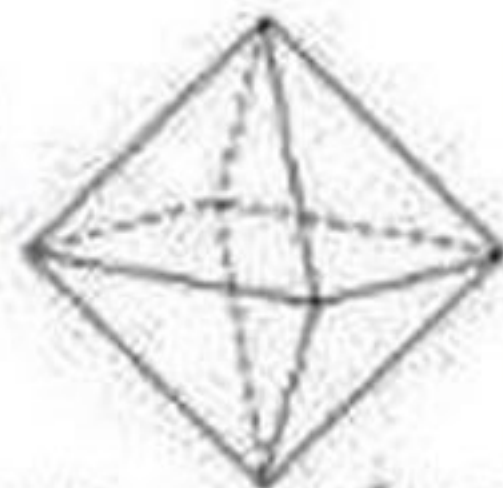

△ X 8

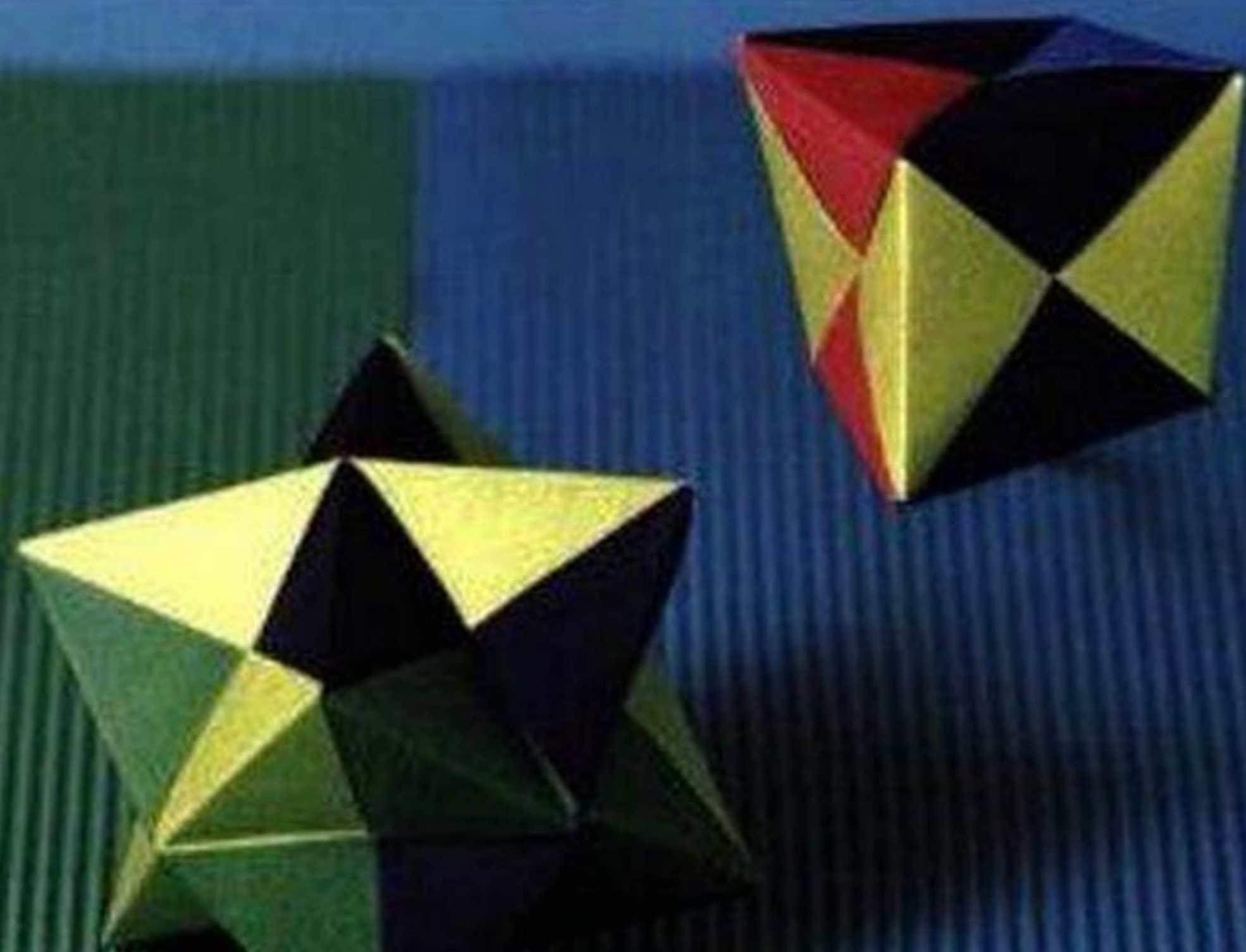



Triangle Unit (p. 92)

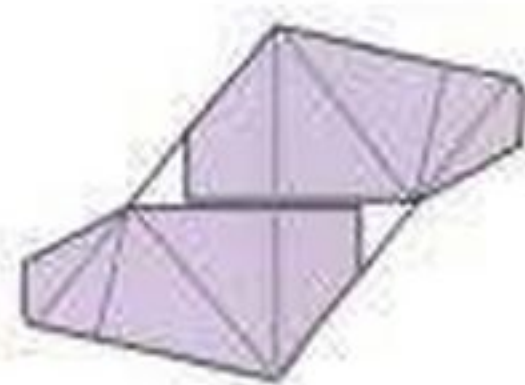

(×30)

Begin with a 3-unit structure.

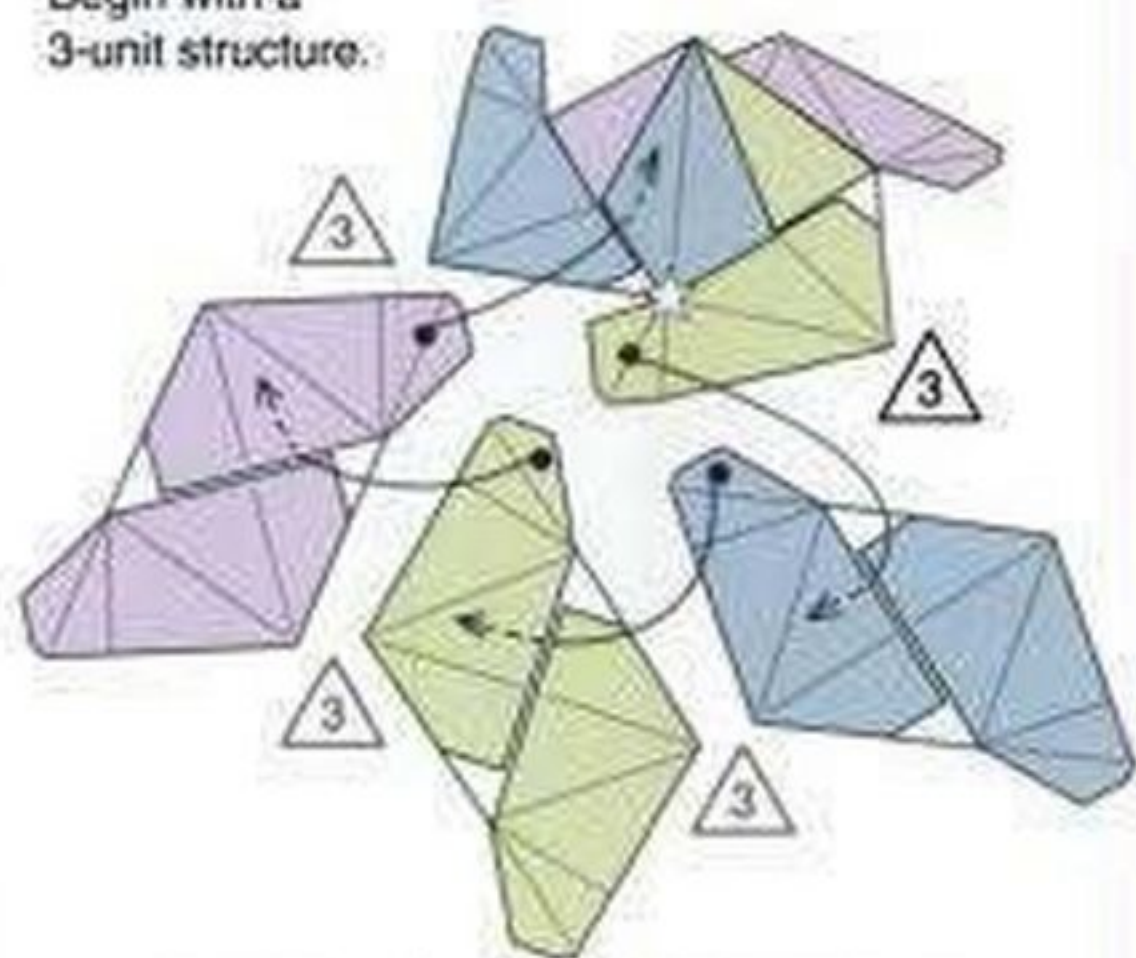

Five triangular pyramids join at the star.



Regular Icosahedron Star

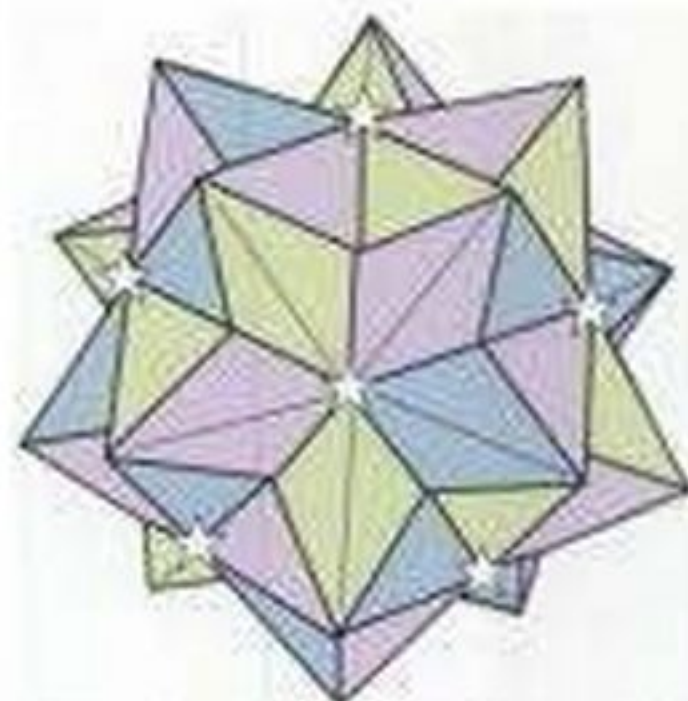

Five triangular pyramids gather at the star.

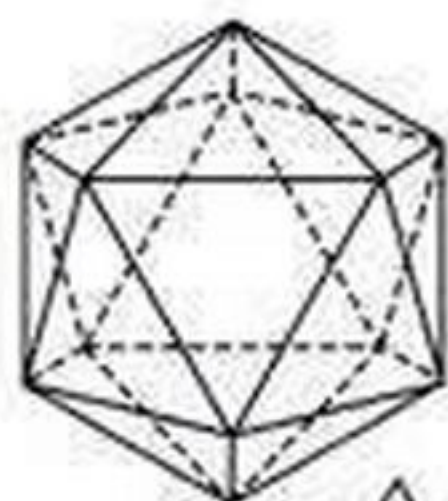

△ × 20

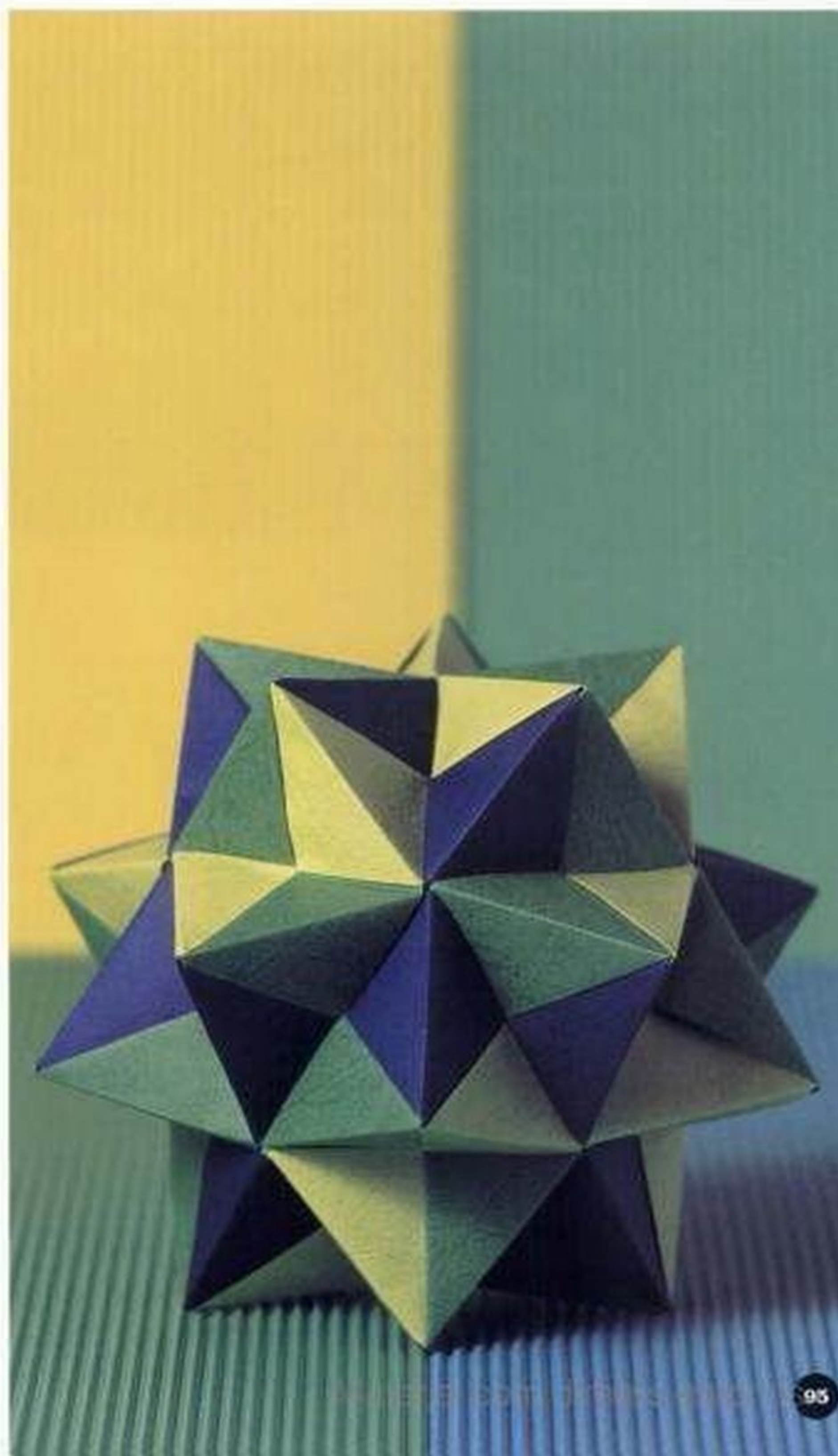



Triangular Unit (p. 92)

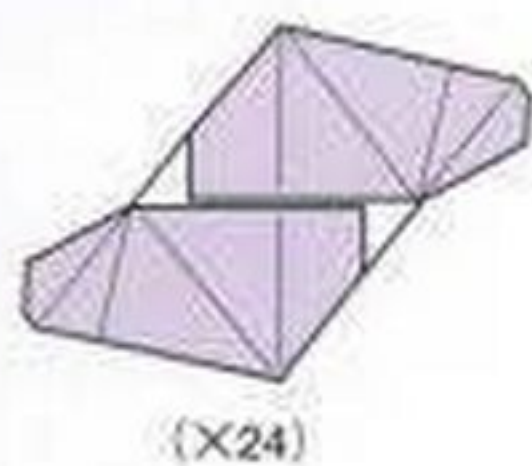

Begin with a 4-unit structure

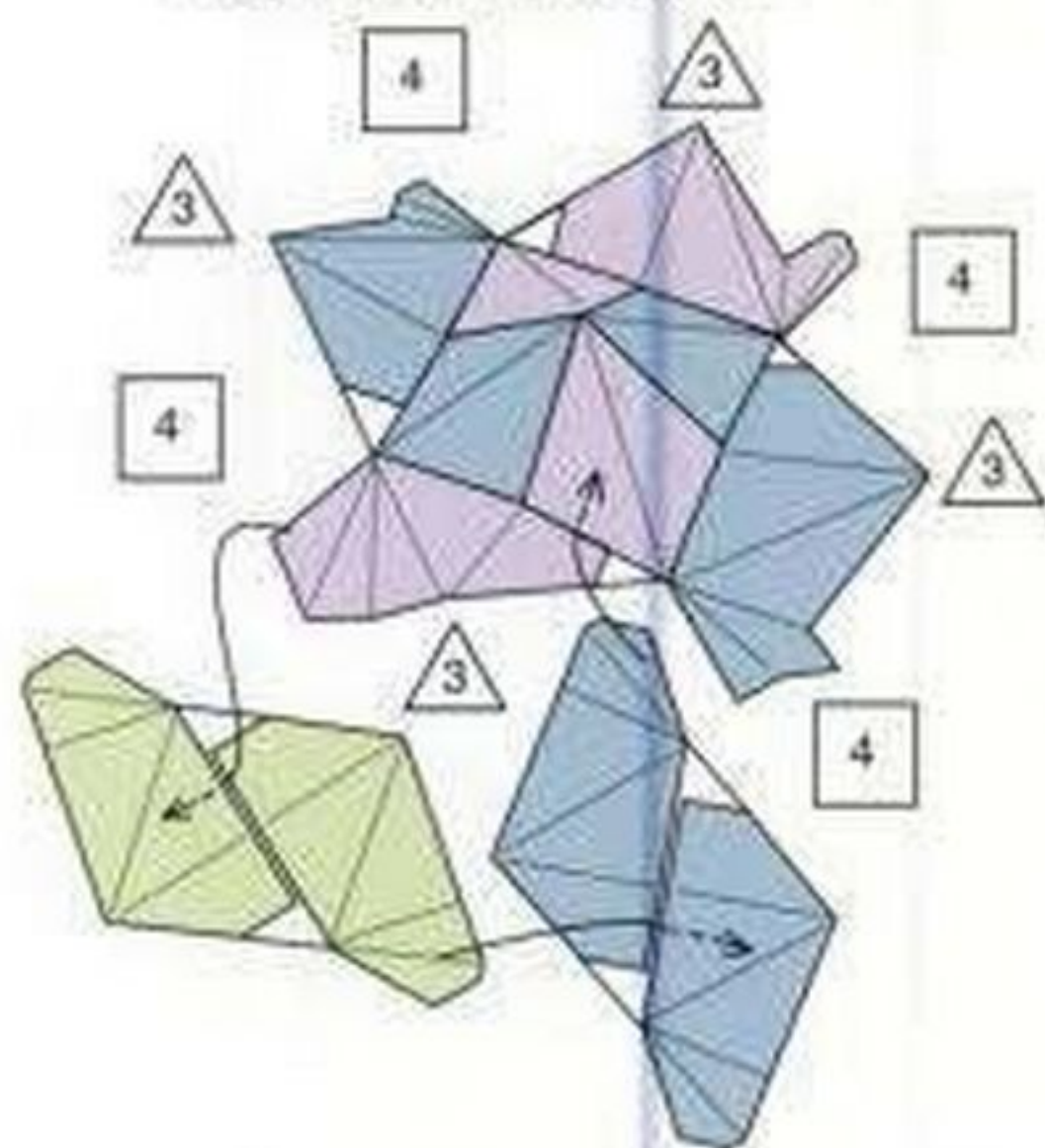

Cuboctahedron Star

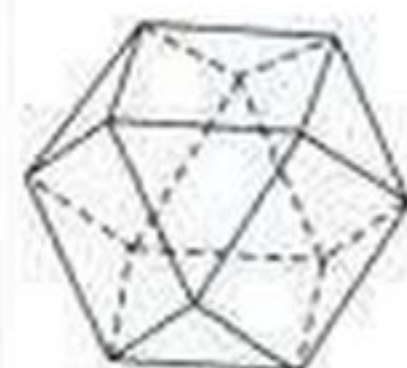
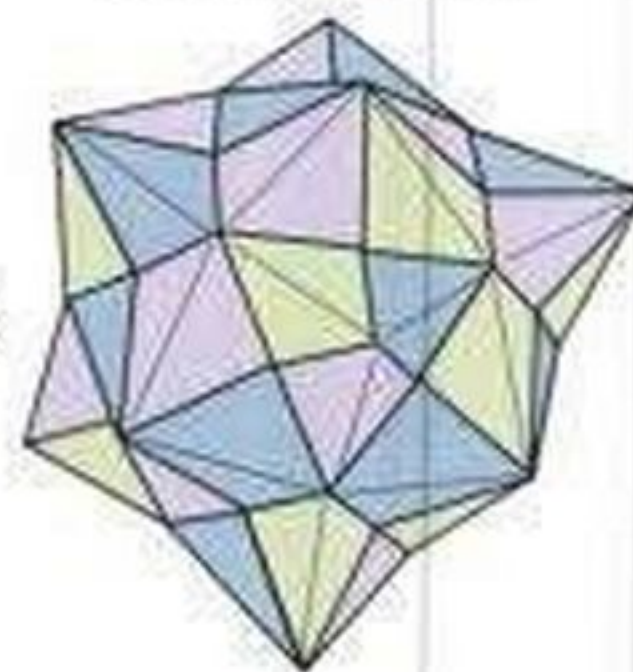

△ × 8 □ × 6

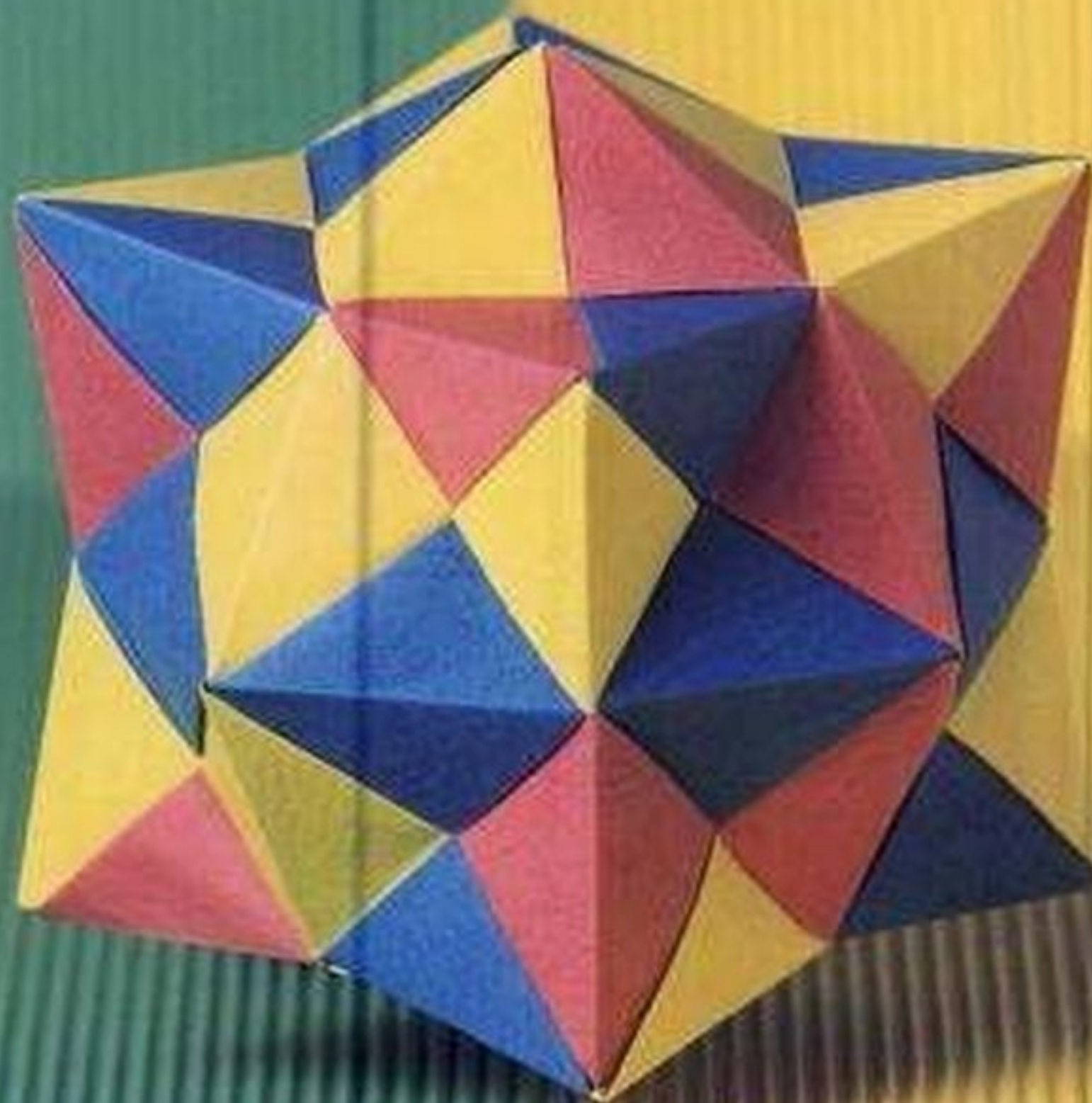



Triangular Unit (p. 92)

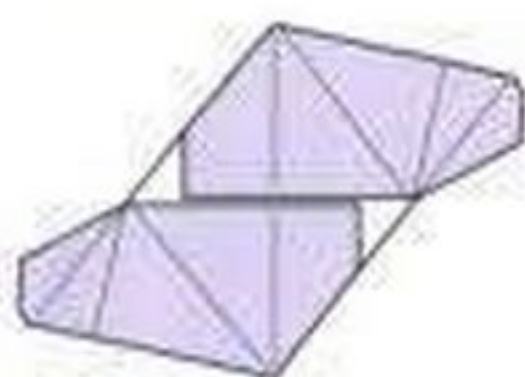

(X48)

Begin with a 4-unit structure.

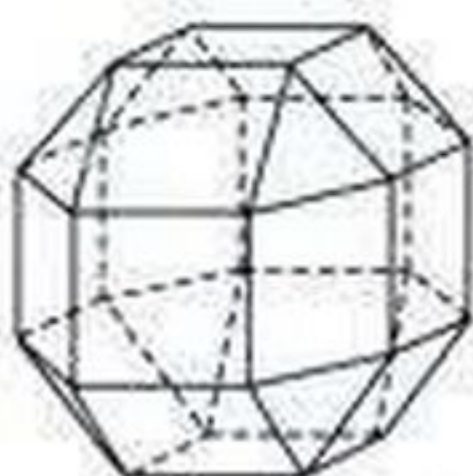
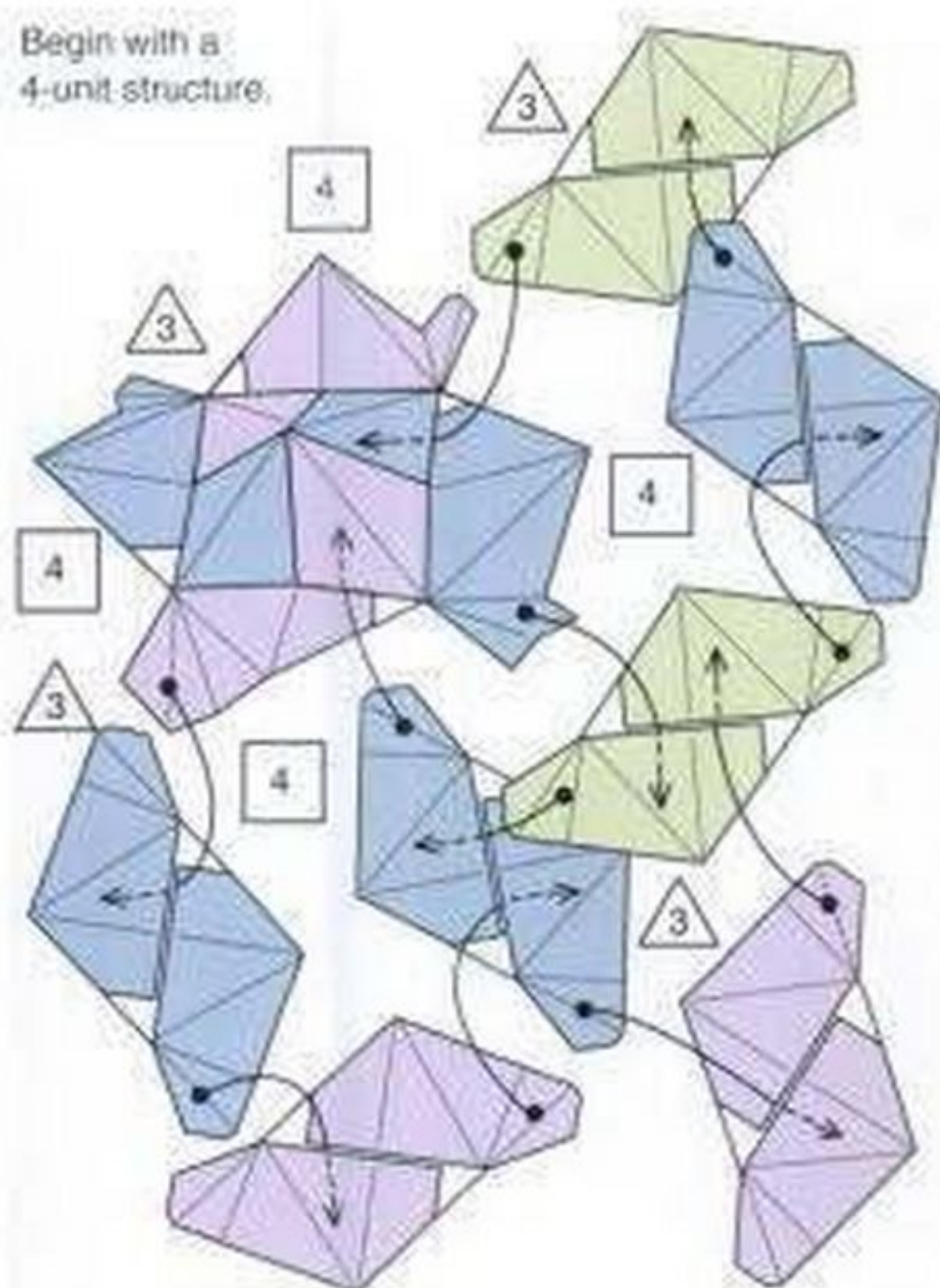

△ X8 □ X18

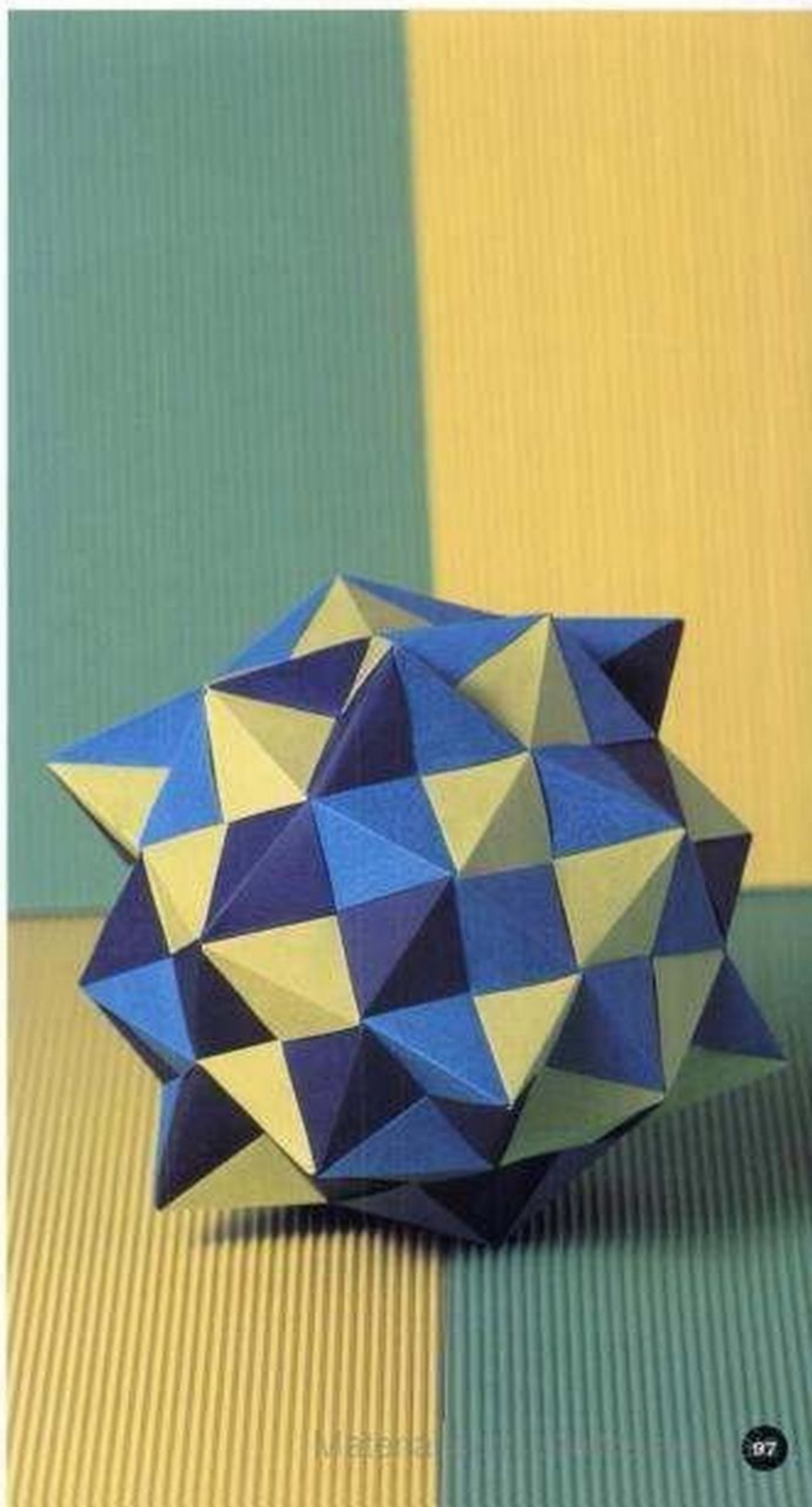



Triangle Unit (p. 92)

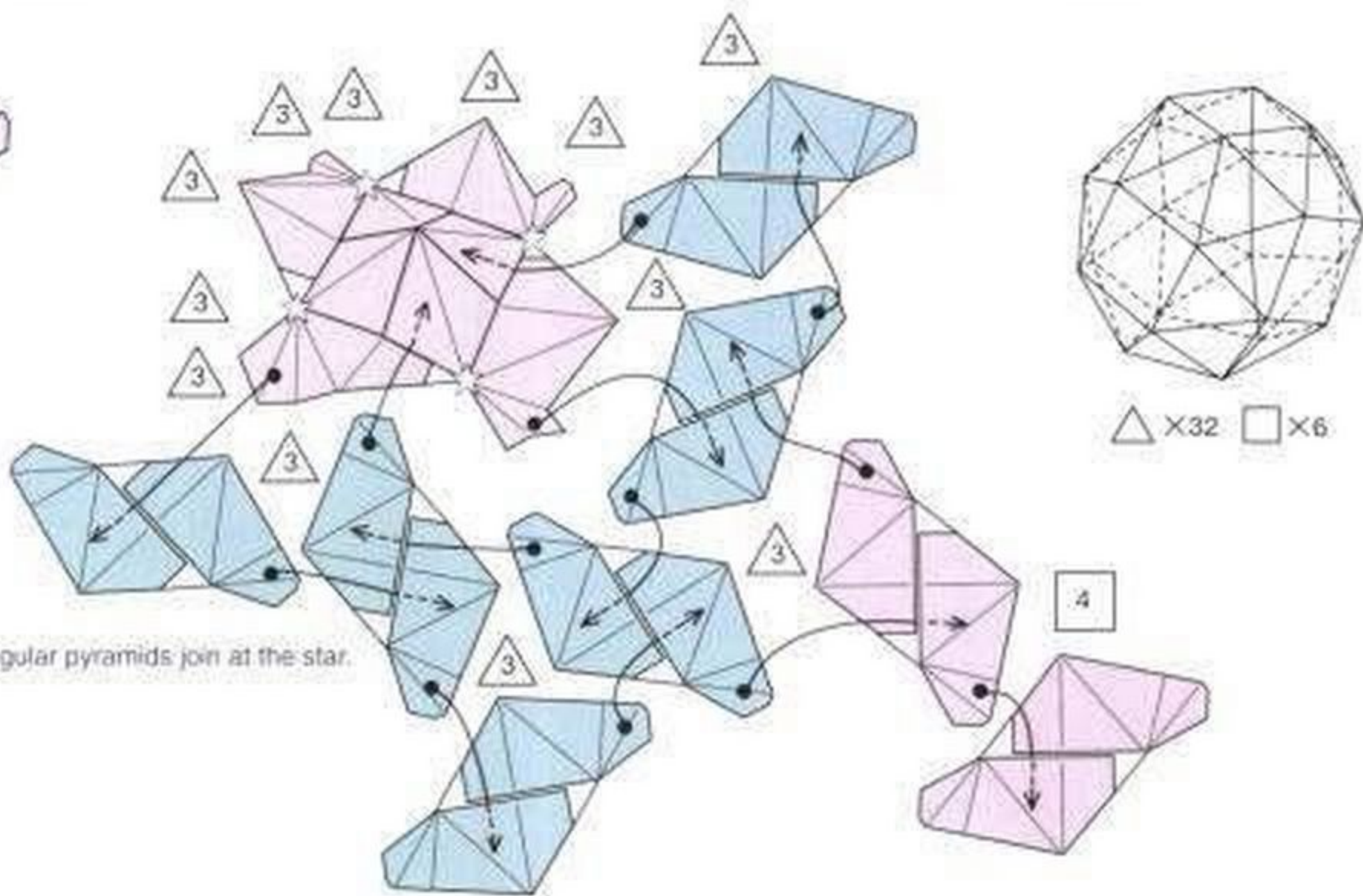
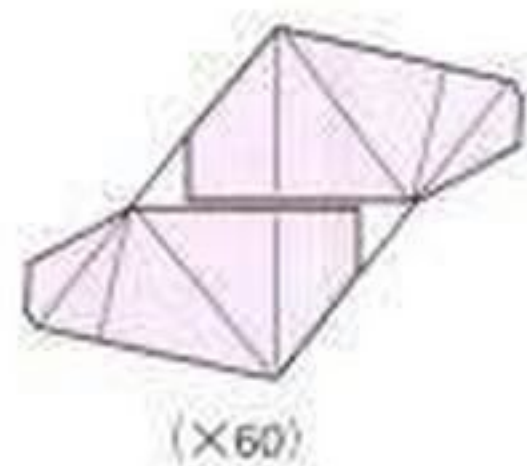

Four triangular pyramids join at the star.

△ X32 □ X6

4

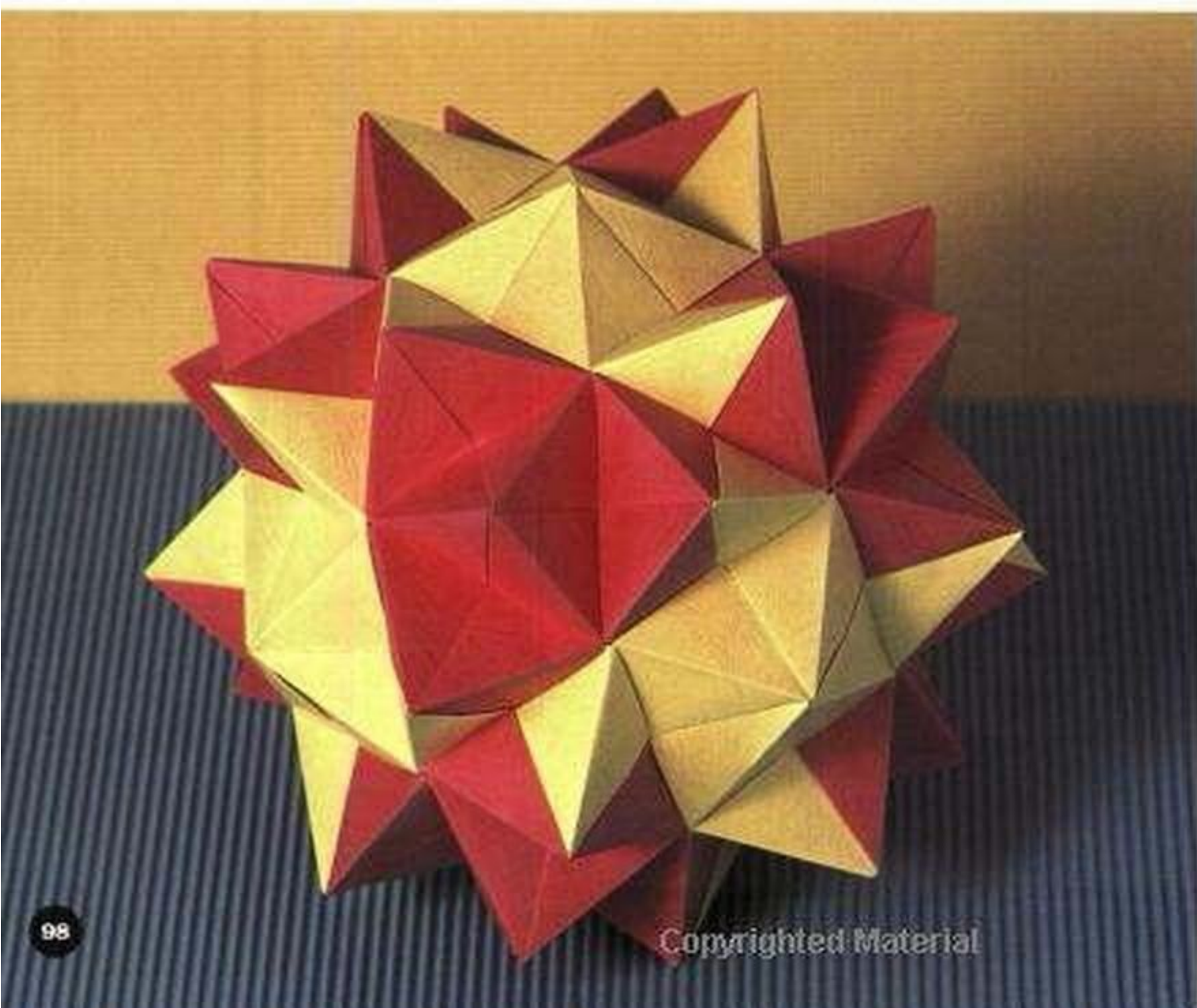



# POLYHEDRONS

Copyrighted Material  
Polyhedrons used in this book.

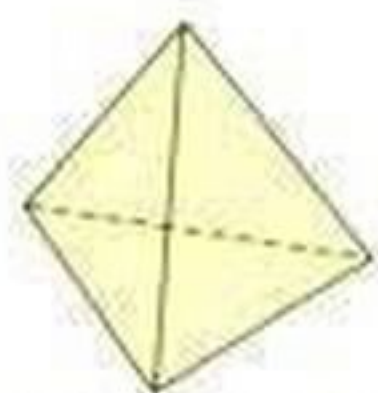

Regular tetrahedron

$\triangle \times 4$
6 sides
4 apices

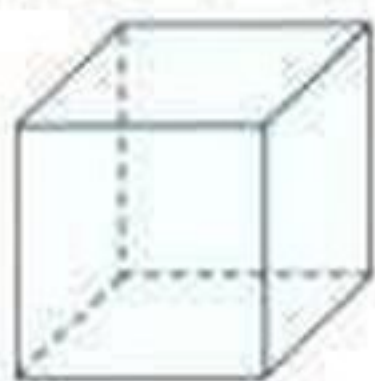

Regular hexahedron (Cube)

$\square \times 6$
12 sides
8 apices

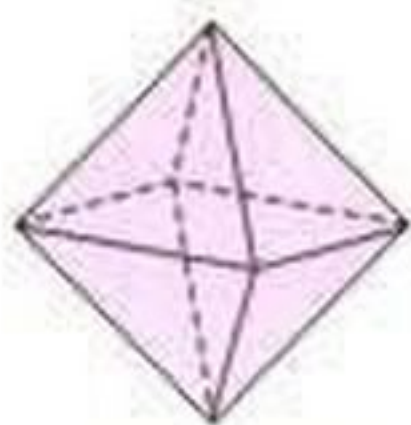

Regular octahedron

$\triangle \times 8$
12 sides
6 apices

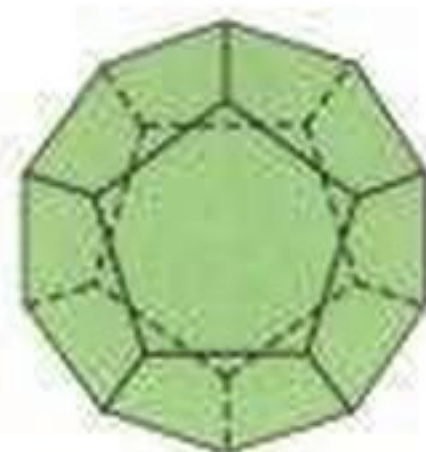

Regular dodecahedron

$\square \times 12$
30 sides
20 apices



Regular icosahedron

$\triangle \times 20$
30 sides
12 apices

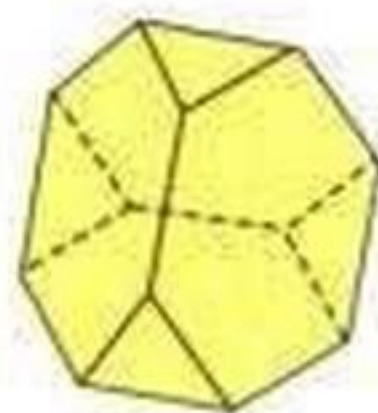

Truncated tetrahedron

$\triangle \times 4$ $\square \times 4$
18 sides
12 apices

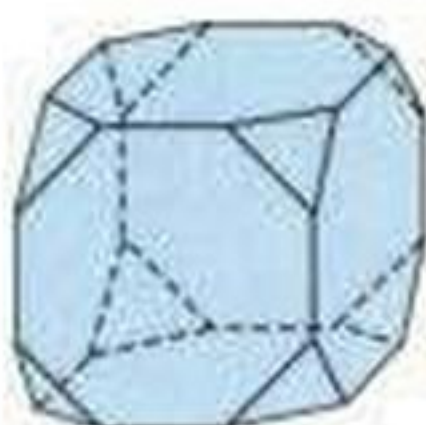

Truncated hexahedron

$\triangle \times 8$ $\square \times 6$
36 sides
24 apices

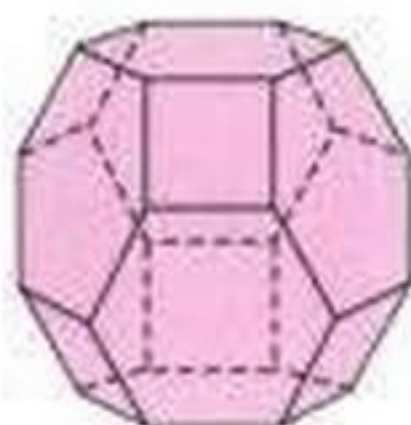

Truncated octahedron

$\square \times 6$ $\square \times 8$
36 sides
24 apices

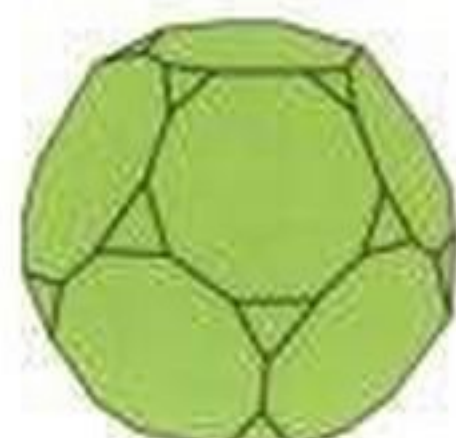

Truncated dodecahedron

$\triangle \times 20$ $\square \times 12$
90 sides
60 apices

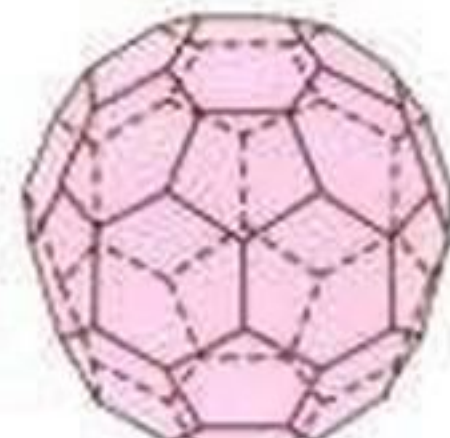

Truncated icosahedron

$\square \times 12$ $\square \times 20$
90 sides
60 apices

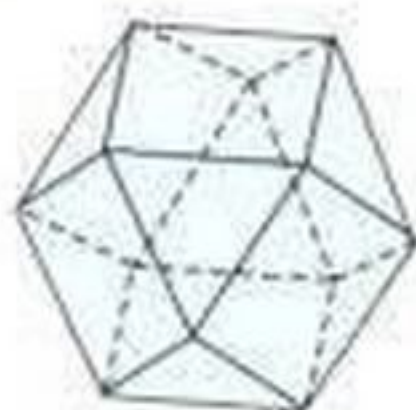

Cuboctahedron

$\triangle \times 8$ $\square \times 6$
24 sides
12 apices

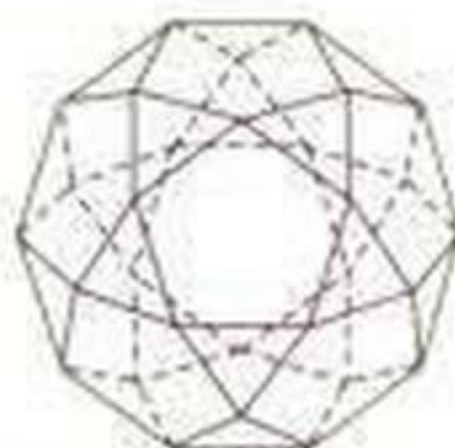

Icosa-dodecahedron

$\triangle \times 20$ $\square \times 12$
60 sides
30 apices

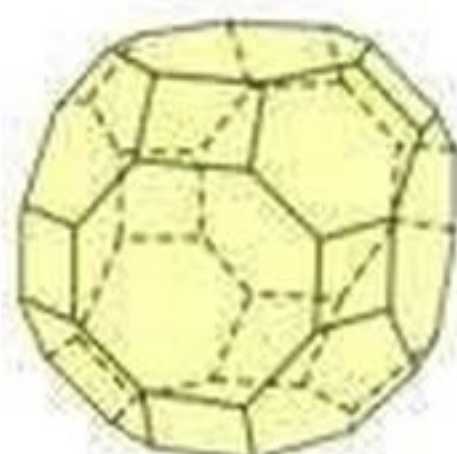

Rhombic truncated octahedron

$\square \times 12$ $\square \times 8$ $\square \times 6$
72 sides
48 apices

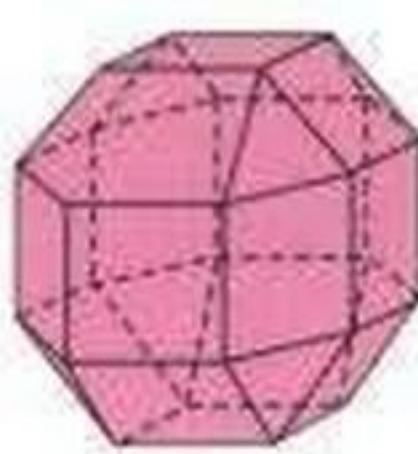

Rhombic cuboctahedron

$\triangle \times 8$ $\square \times 18$
48 sides
24 apices

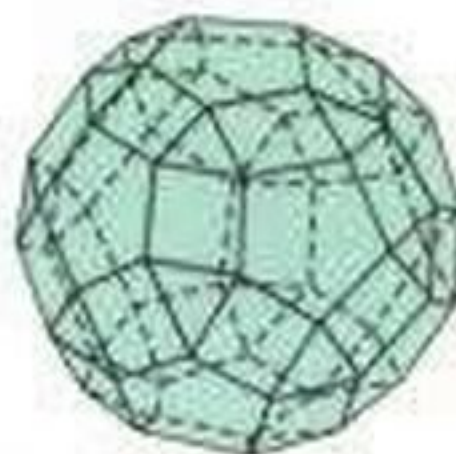

Rhombic icsa-dodecahedron

$\triangle \times 20$ $\square \times 30$ $\square \times 12$
120 sides
60 apices

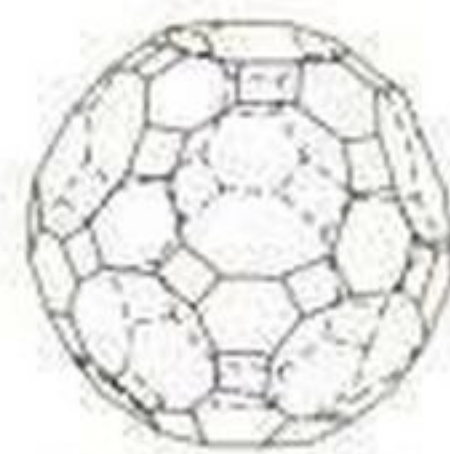

Rhombic truncated icsa-dodecahedron

$\square \times 30$ $\square \times 20$ $\square \times 12$
180 sides
120 apices

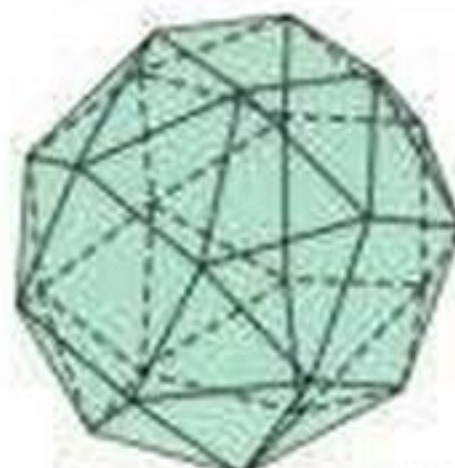

Variant cube

$\triangle \times 32$ $\square \times 6$
60 sides
24 apices



Variant dodecahedron

$\triangle \times 80$ $\square \times 12$
150 sides
60 apices

Copyrighted Material



1

## SQUARE AND EQUILATERAL TRIANGULAR FLAT UNITS

Each side has a pocket into which a joint is inserted to make three-dimensional figures.

**Regular  
Tetrahedron** /p.11

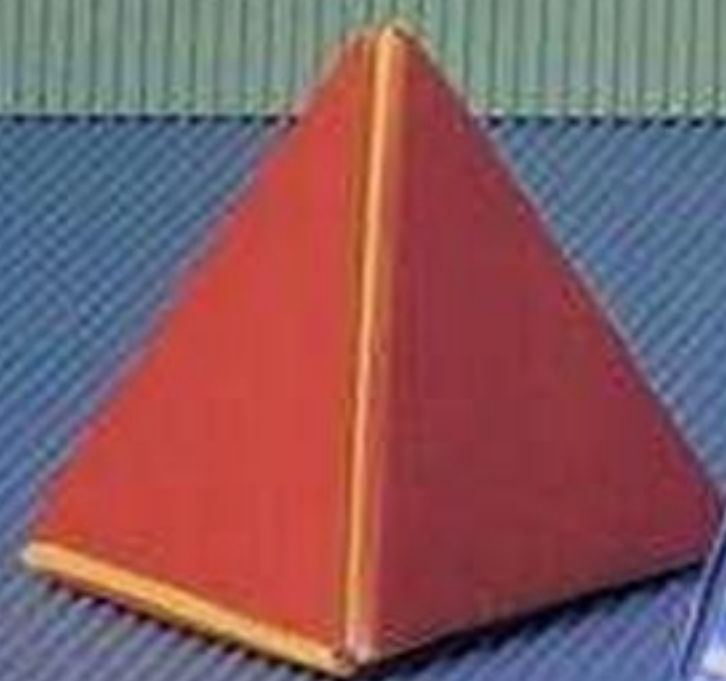

**Regular Octahedron** /p.12



**Truncated Regular  
Tetrahedron** /p.13

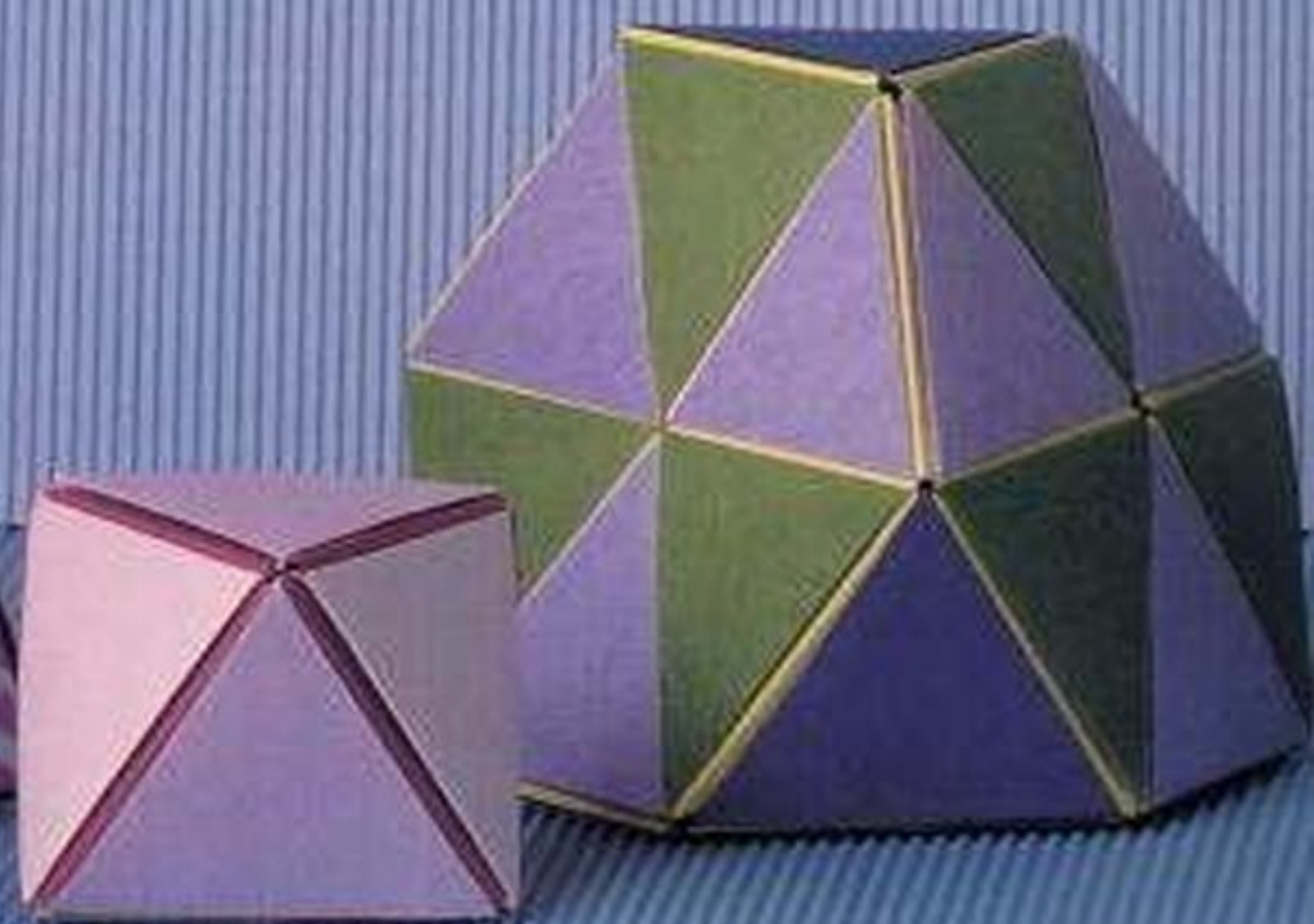



**Regular Icosahedron /p.12**



**Cubes /p.9**





# SQUARE FLAT UNITS

level ★

15cm × 15cm

Assemble by inserting joints into four pockets.

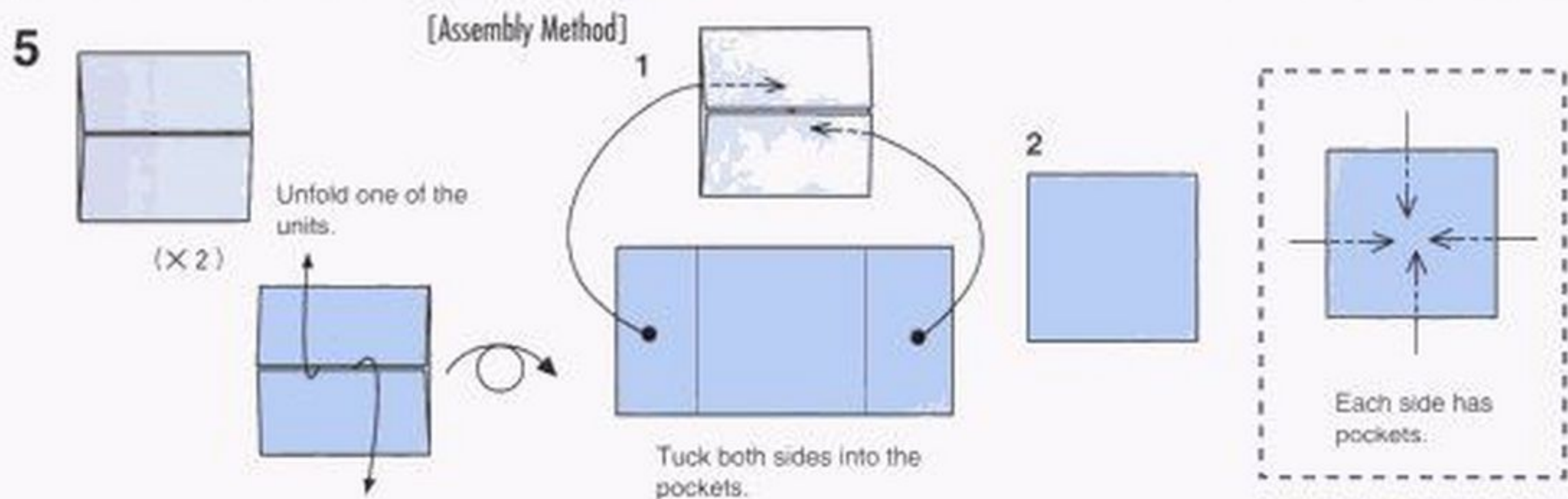
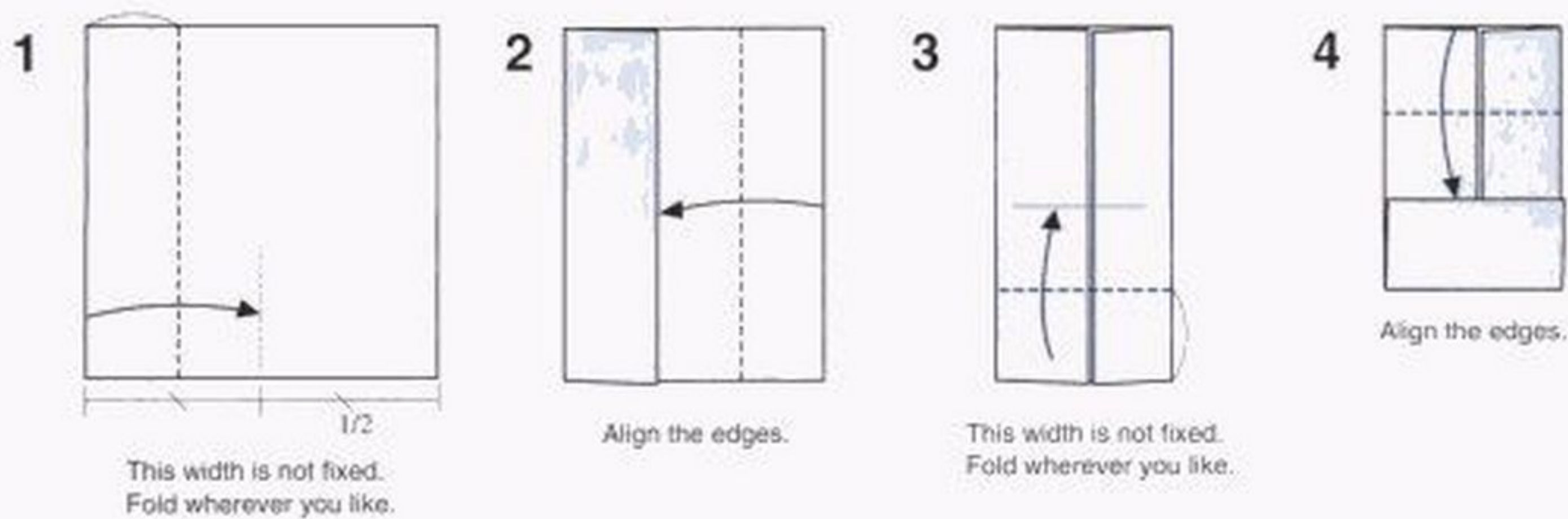

**Joints** ● Use Method A for joints, but when the paper is thick or difficult to assemble, use B.

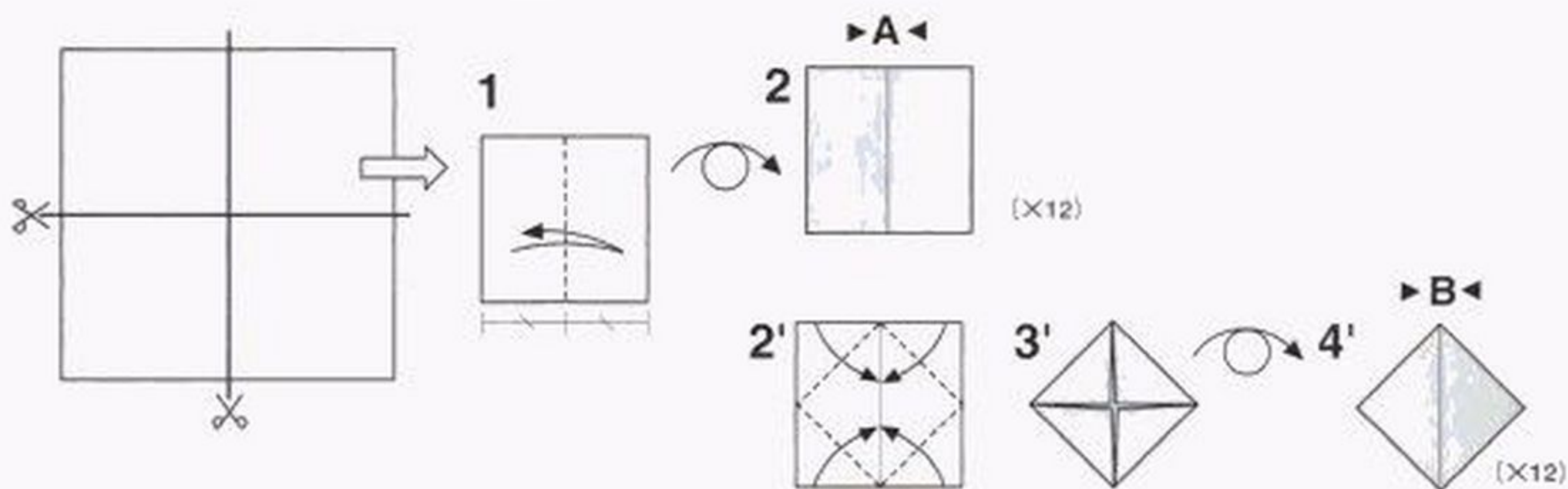



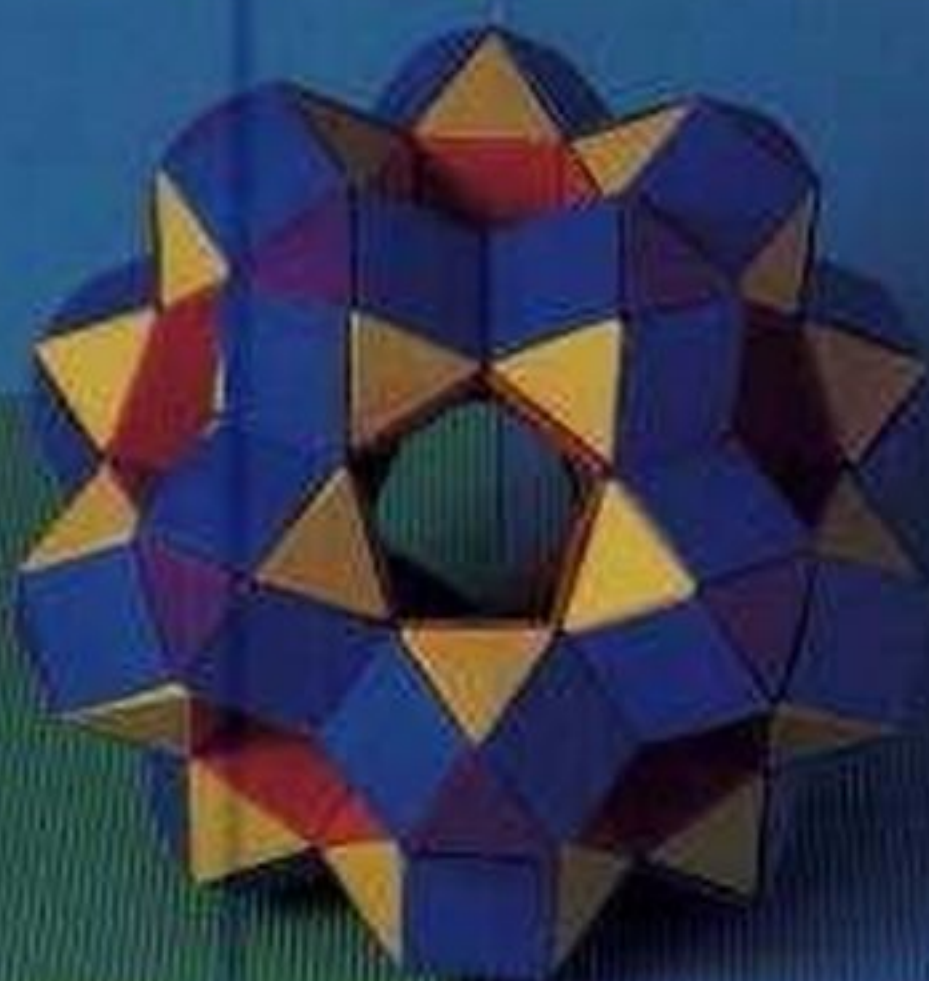
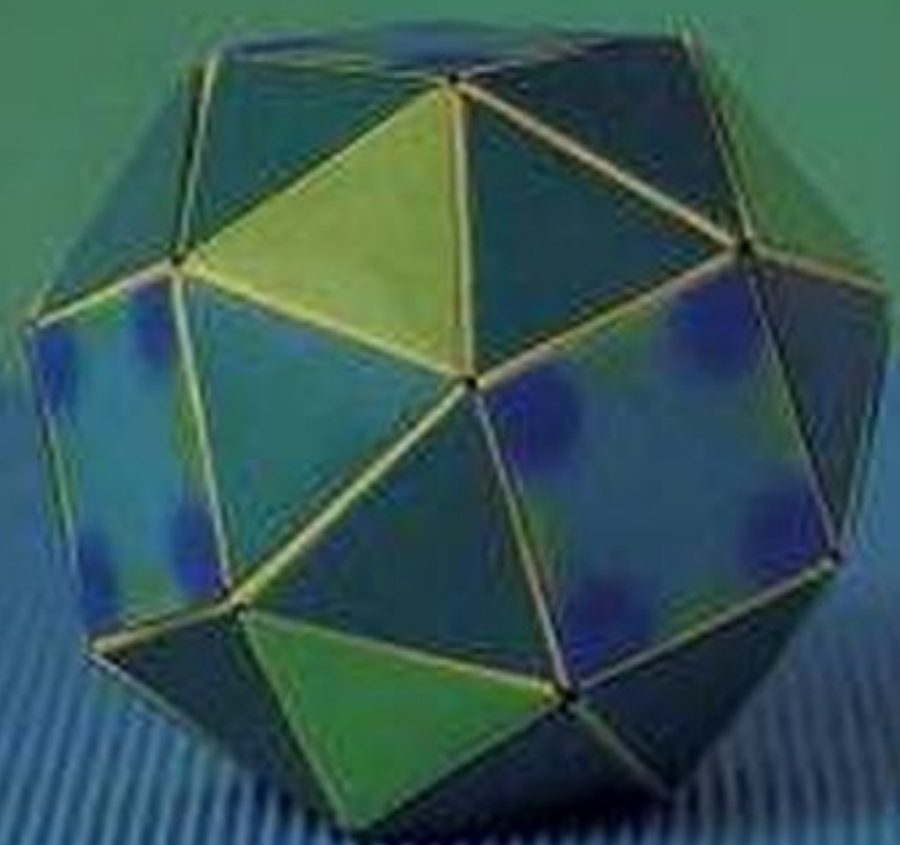

**UNIT**  
POLYHEDRON  
ORIGAMI



US\$20.95

ISBN 4-88996-205-0



9 784889 962055

JAPAN PUBLICATIONS TRADING CO., LTD.

Printed in Japan