

The Complete Visual Guide to Building a House

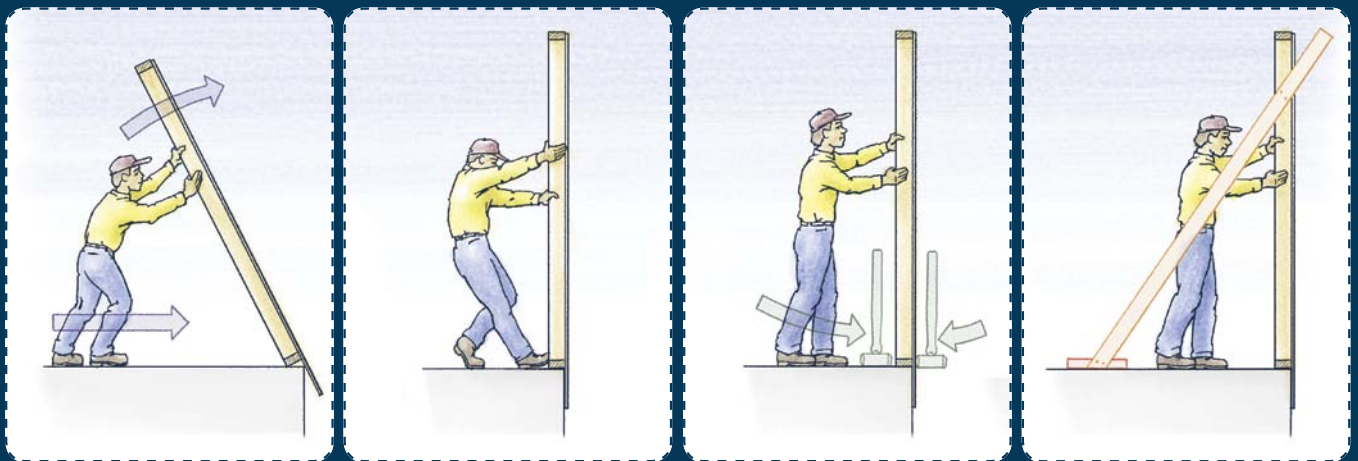

John Carroll and Chuck Lockhart

The
Complete
Visual Guide to
Building
a House

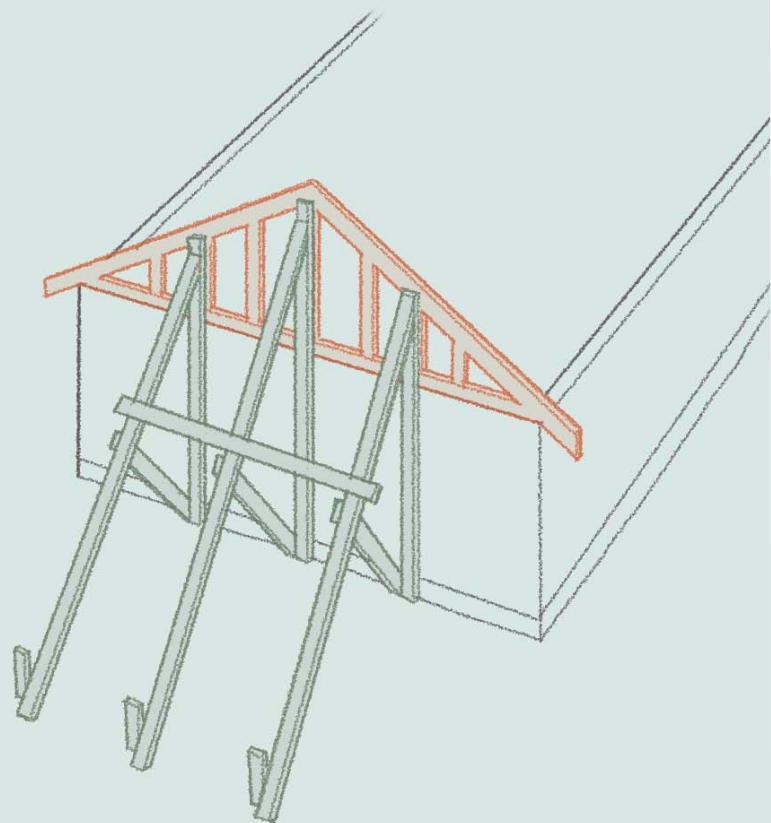
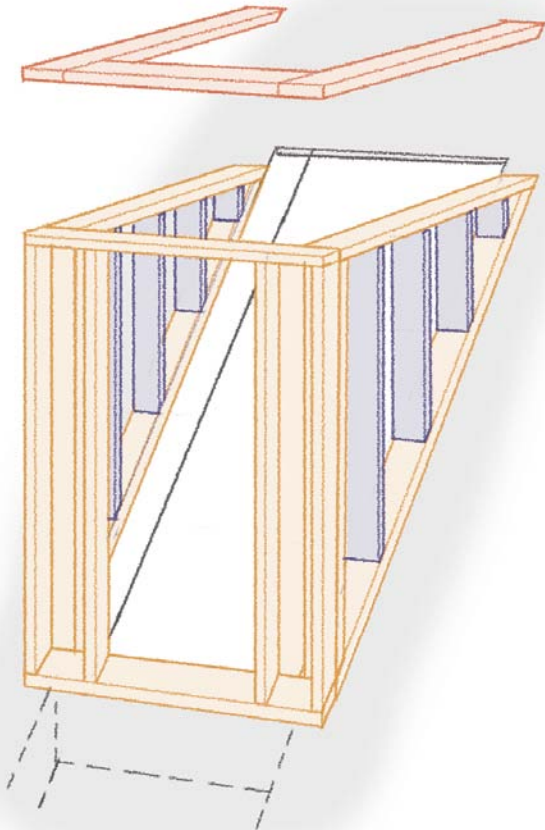
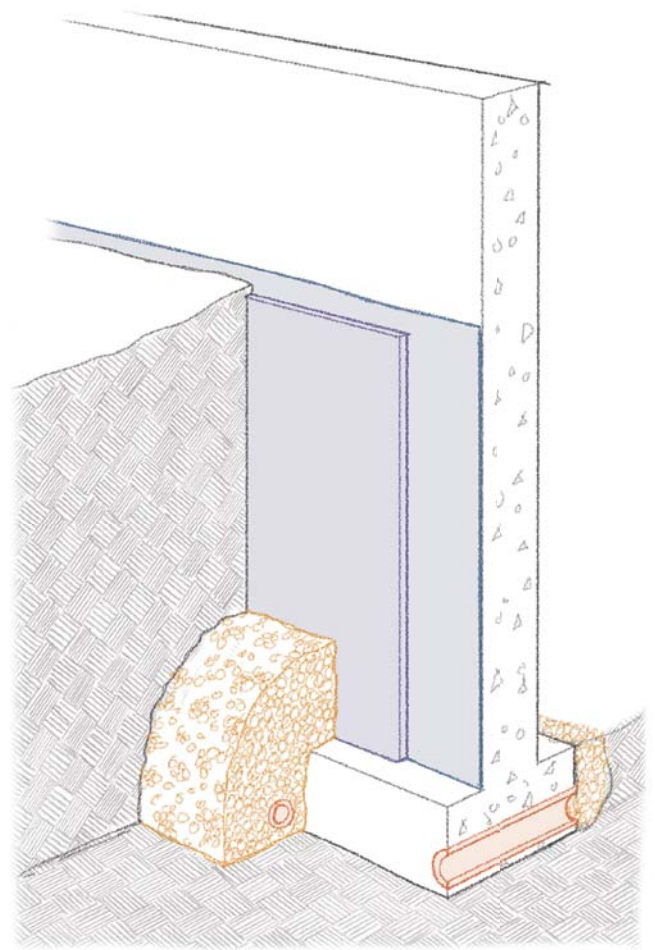
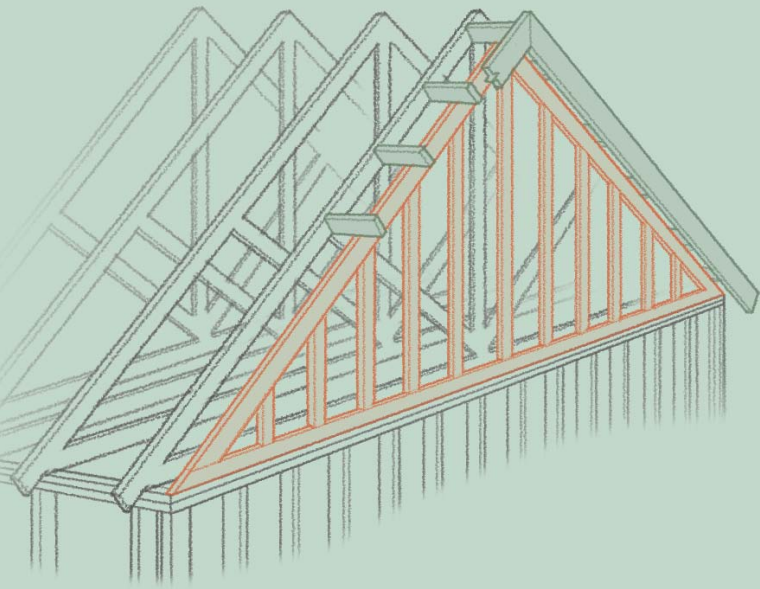

The
Complete
Visual Guide to
Building
a House

John Carroll and Chuck Lockhart



The Taunton Press

Text © 2013 by The Taunton Press, Inc.
Illustrations © 2013 by The Taunton Press, Inc.
All rights reserved.



The Taunton Press
Inspiration for hands-on living®

The Taunton Press, Inc., 63 South Main Street, PO Box 5506, Newtown, CT 06470-5506
e-mail: tp@taunton.com

Editors: PETER CHAPMAN, SCOTT GIBSON
Copy editor: DIANE SINITSKY
Indexer: JIM CURTIS
Jacket/Cover design: JEAN-MARC TRODAEC
Interior design: carol singer | notice design
Layout: CATHY CASSIDY, CHUCK LOCKHART
Illustrator: CHUCK LOCKHART

The following names/manufacturers appearing in *The Complete Visual Guide to Building a House* are trademarks: Backer-On™; C. H. Hanson® Pivot Square™; CavClear®; Cor-A-Vent®; Dap® Presto Patch®; Deck-Armor™; Delta®-MS; DensShield®; DrainWrap™; DuPont StraightFlash™; DuPont™ FlexWrap™; Durock®; Festool®; FoamSealR™; HardieBacker®; Home Slicker®; Ice & Water Shield®; JambSill Guard®; Level-Best®; McFeely's®; MortarNet®; Osmose®; Porter-Cable®; RainDrop®; RockRipper®; Roofer's Select™; Schluter®-DITRA; Sheetrock®; Shingle Mate®; Simpson Strong-Tie®; Stanley® Quick Square®; StormGuard®; Super ThoroSeal®; Sure-Tite™; SureCorner™; SureSill™ HeadFlash™ and HeadFlash-Flex™; Swanson® Big 12® Speed® Square; T-JAK®; Tapcon®; Telpro® Panellift®; Timberline®; Titanium® 30; Typar®; Tyvek® StuccoWrap®; Warm-N-Dri®; Warner® Tool; WaterWay™; Weathermate™ Sill Pan; WeatherTrek®; WinterGuard™; Wolman™; WonderBoard®

Library of Congress Cataloging-in-Publication Data

Carroll, John (John Michael), 1949-

The complete visual guide to building a house / John Carroll and Chuck Lockhart.
pages cm

Includes index.

E-Book ISBN 978-1-62710-608-5

1. House construction--Handbooks, manuals, etc. 2. House construction--Pictorial works. I. Lockhart, Chuck. II. Title.

TH4813.C37 2014

690'.837--dc23

2013048589

Printed in the United States of America

10 9 8 7 6 5 4 3 2 1

ABOUT YOUR SAFETY: Construction is inherently dangerous. Using hand or power tools improperly or ignoring safety practices can lead to permanent injury or even death. Don't try to perform operations you learn about here (or elsewhere) unless you're certain they are safe for you. If something about an operation doesn't feel right, don't do it. Look for another way. We want you to enjoy working on your home, so please keep safety foremost in your mind.

For my mother, EMILY J. CARROLL (1923–2012)

ACKNOWLEDGMENTS

THE IDEA FOR THIS BOOK CAME FROM STEVE CULPEPPER, who, at the time, served as executive book editor for The Taunton Press. In looking at the available general guides to residential building, Steve found that most were several decades old and contained outdated information. He felt there was a need for a reference that reflected today's building industry, and, to my good fortune, he thought I should be the one to write it.

Shortly after I started writing this book, however, Steve left Taunton and Peter Chapman took over as book editor. In addition to all his other duties, Peter served as the primary editor of this book. Peter's help proved to be invaluable. I am especially grateful for his forbearance with me as a writer whose "cup runneth over" on a regular basis. In chapter after chapter, I submitted too many words and too much information, so Peter would patiently work with me to pare the text down to a manageable size. With Peter's help, I was able to identify the essential information and present it in a much more concise manner. His insights and suggestions made this book shorter, clearer, and better organized.

My in-depth discussion of common building procedures would be confusing without accompanying drawings. To graphically represent what I've described, The Taunton Press brought in one of the finest illustrators in the business, Chuck Lockhart. Having worked as art director for *Fine Homebuilding* magazine for 18 years, Chuck brought a wealth of experience to this project. His drawings are more extensive and provide more detail than would have been possible with photographs, which require access to building projects at key moments in the job. Anything I could describe Chuck could draw. Chuck was able to highlight key details through the use of color and shading; in many drawings, Chuck skillfully employed such devices as cutaway views and cross-sectional drawings to show how the details of the job fit into the whole.

After all the parts of this book were produced, the unenviable task of putting them together fell to Scott Gibson. A skilled carpenter and an accomplished writer and editor, Scott went through every word of text and every drawing. In addition to looking for and finding mistakes, inconsistencies, and omissions, Scott extracted information from the running text and applied it, in the form of labels, to the drawings. His painstaking attention to detail, his focus on accuracy, and his knowledge of current building practices—especially the latest in building science—were extremely helpful and greatly improved the quality of this book.

—John Carroll

TABLE OF CONTENTS

INTRODUCTION

PART ONE

Building the Structure 4

CHAPTER 1

Building Foundations 6

CHAPTER 2

Framing Floors, Walls, and Ceilings 50

CHAPTER 3

Framing Roofs 1: Raftered Roofs 98

CHAPTER 4

Framing Roofs 2: Trusses, Eaves, Rakes, and Sheathing 142

PART TWO

Closing the House to the Weather 182

CHAPTER 5

Roofing the House 184

CHAPTER 6

Installing Windows, Exterior Doors, Siding, and Trim 231

CHAPTER 7

Controlling Moisture in the Ground and in the Air 278

PART THREE

Finishing the House 308

CHAPTER 8

Installing Wall and Floor Coverings 310

CHAPTER 9

Hanging Doors 354

CHAPTER 10

Installing Trim and Cabinets 396

CHAPTER 11

Building Stairs 442

APPENDICES

Conversions 500

Base-1 Proportions of Standard Roof Pitches 501

Backing Angles for Regular Hips and Valleys 502

Base-1 Proportions of Regular Hips and Valley Pitches 503

Converting X-in-12 Roof Pitch to Degrees of an Angle 504

Converting X-in-16.97 Roof Pitch to Degrees 505

Miter and Bevel Settings for Crown Molding 506

Index 514

INTRODUCTION

IN AMERICA, HOUSES ARE BUILT IN areas where several feet of snow accumulate, where hurricanes can be expected, or where temperatures exceed 100°F. In some areas, all these conditions might occur within the same year. Within these very different climatic regions, furthermore, individual building sites pose a wide variety of challenges. The surface of the land might slope steeply; the soil might contain expansive clay or bedrock; or there might be too much moisture in the ground.

To meet these and other challenges, builders have to adjust the design of their houses to the climatic and topographical conditions of the area they live in. In Florida, for example, roof structures must be tied down with steel straps to keep them from being lifted off the walls during hurricanes. In Maine, on the other hand, roof frames must be beefed up to keep them from collapsing under the weight of several feet of snow. These measures, which are required by building codes, go a long way toward creating durable houses.

Beyond simply building houses that last, however, builders need to create houses that perform. Once viewed as basic shelters from the extremes of the weather, houses are now seen as climate-controlled enclaves. Most people expect the environment inside their house to be comfortable year-round, no matter how brutal the weather is outside. Accomplishing this goal in the face of ever-increasing energy costs is one of the biggest challenges confronting builders today. Again, the plan of attack has to be tailored to the location of the house. A house that keeps a family warm during the winter on the Northern Plains has to be built much differently than a house that provides relief from the heat and humidity in the Deep South.

The diverse local requirements of home building coupled with an ever-expanding choice of building materials, tools, and systems present a fundamental problem for a book like this one. Because there are so many approaches and options, it's difficult to decide what to discuss and how detailed that discussion should be. As on any major building project, there have been many hard decisions to make and there have been many interesting and worthwhile topics that I could not include in this book.

The first thing I decided to drop was a comparative analysis of different building systems. There are at least a half-dozen alternatives to the light wood-framed house in America. However, builders and homeowners continue to vote with their wallets for the wood-framed house, which accounts for 90% of the houses in the United States and Canada. Rather than devote a good portion of this book to a discussion of the strengths and weaknesses of the other systems, I chose to focus on the one system that dominates the housing market: the wood-framed house.

Along the same lines, I've focused on mainstream materials when describing the rest of the house. In the chapter on foundations, for example, I concentrated on concrete and masonry, and in the chapter on roofing, I focused on asphalt shingles because most houses in America are built with those materials. If you happen to use materials that are outside of the mainstream, there's a good chance that the installation techniques presented here will work, with minor adjustments, with the materials you use.

I've also focused on common building projects and designs. Throughout the book, I posed hypothetical building projects and then suggested ways to build them. In these projects, the rectangle predominated—just as it does on most residential building sites. In general, I have steered clear of complex designs, such as octangular buildings and curved staircases—both because they couldn't be covered adequately in the space allotted and because they are rare in American houses.

Sticking with common design elements and mainstream materials has allowed me to go into considerable detail when describing building techniques. These details are often vital to the quality of the job, and builders who overlook them or try to force them in as an afterthought usually end up with substandard work. Throughout this book, therefore, I've hammered home the idea that quality work requires two things: forethought and the proper sequence of installation. It's essential to think through the details at the beginning of the job and then install them at just the right moment.

No book, including this one, can provide every important detail for every job. What I've tried to do here is show how to look at the job, anticipate problems, and then work in the optimal sequence to fit the parts together smoothly and correctly. Learn these lessons well and you'll find it easy to progress to more complex jobs.

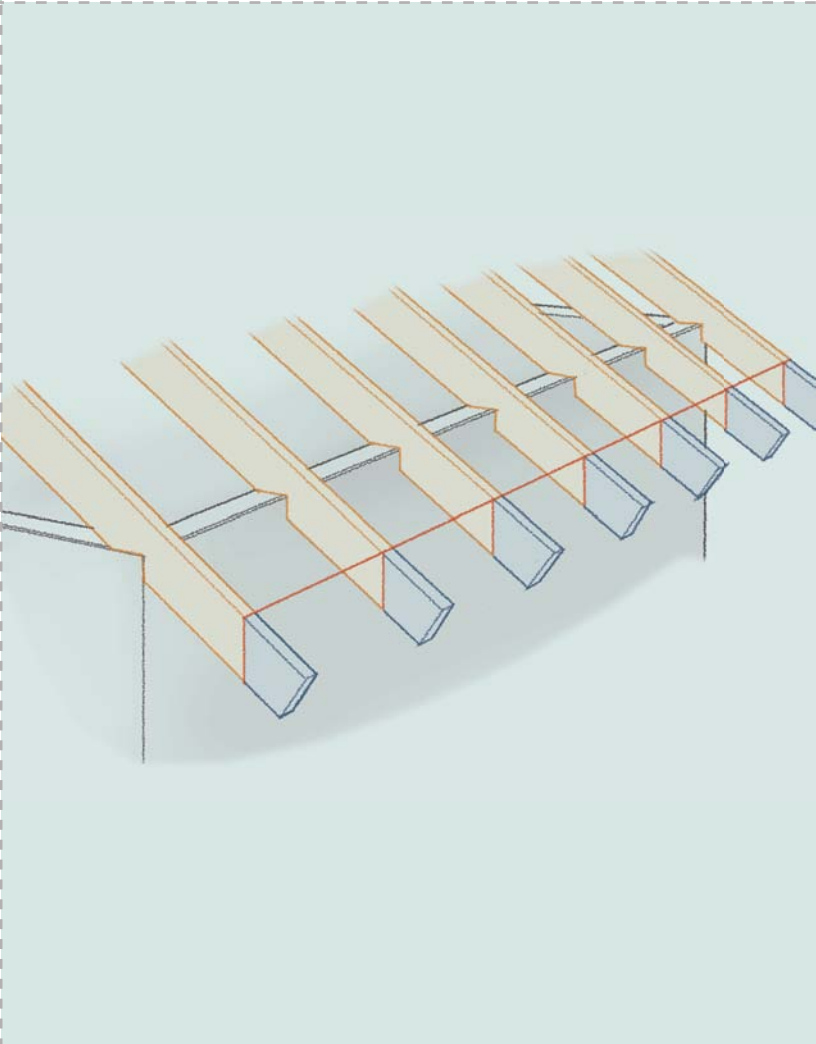
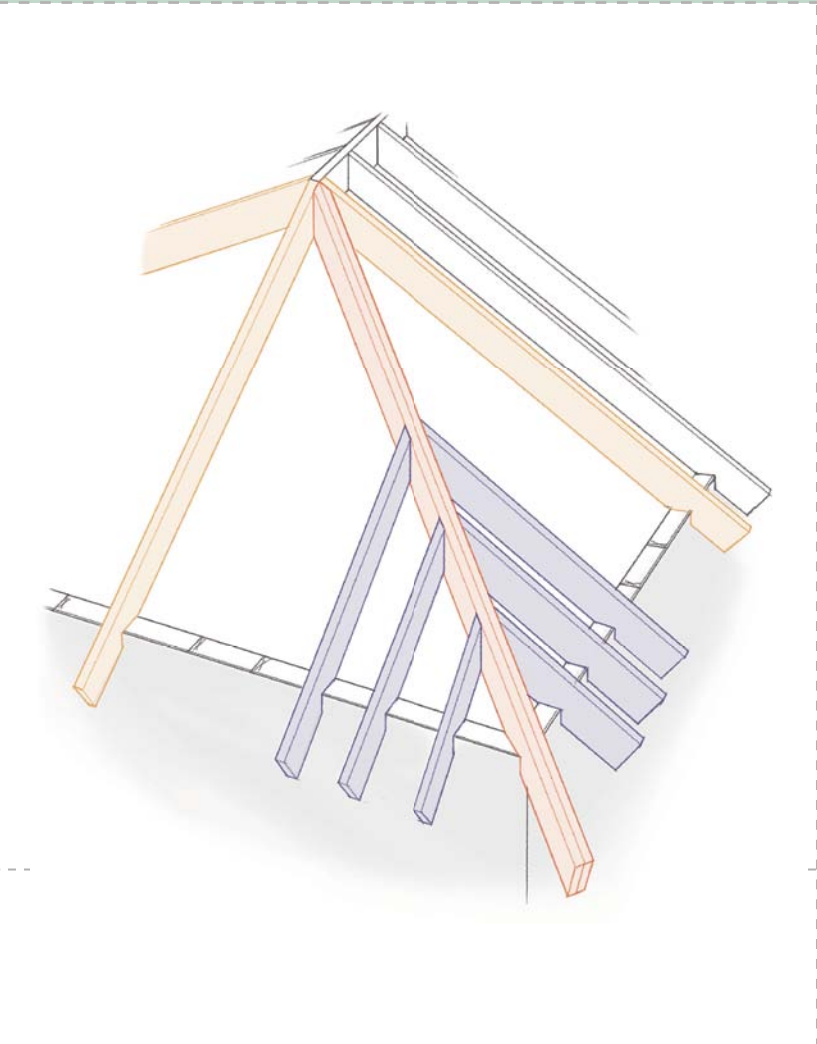
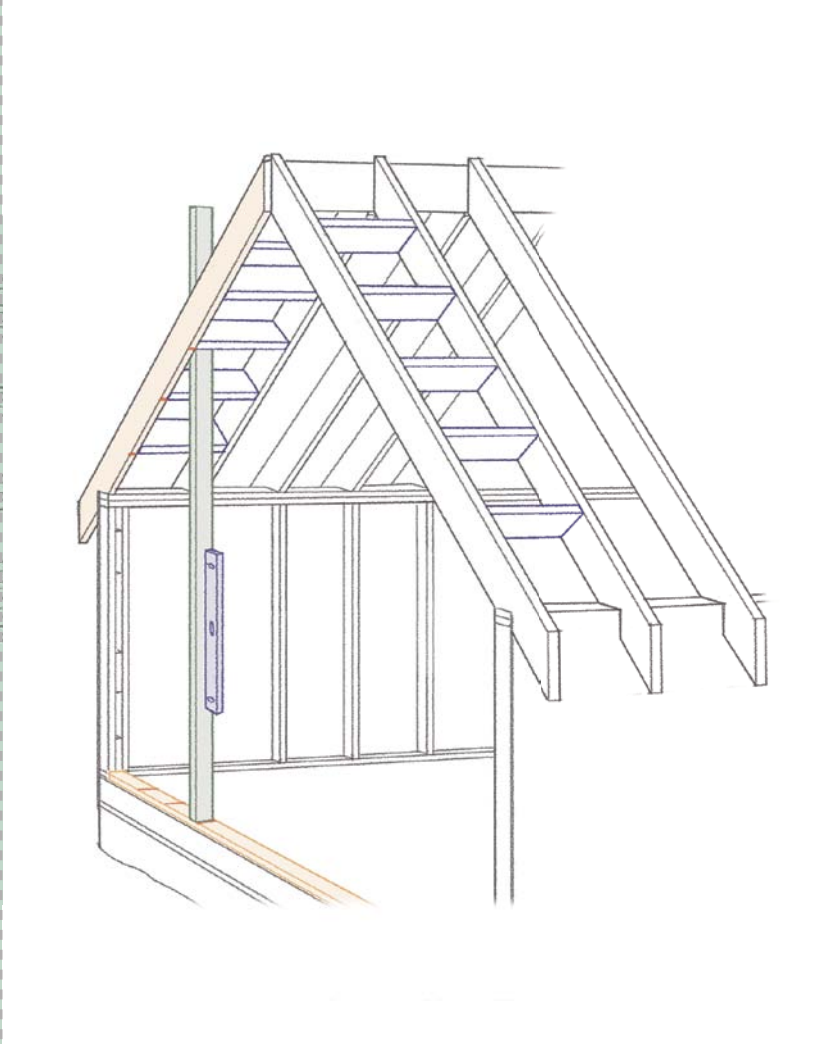
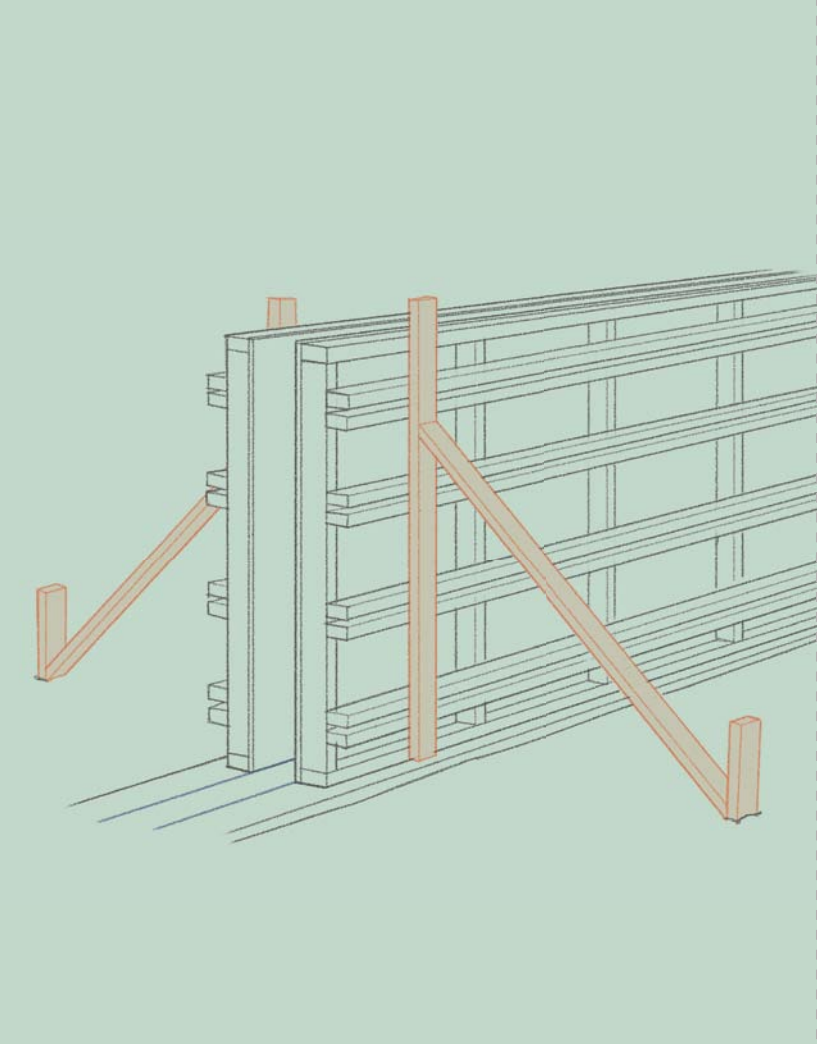

Building the Structure

CHAPTER 1

.....

6 Building Foundations

CHAPTER 2

.....

50 Framing Floors, Walls, and Ceilings

CHAPTER 3

.....

98 Framing Roofs 1: Raftered Roofs

CHAPTER 4

.....

142 Framing Roofs 2: Trusses, Eaves,
Rakes, and Sheathing

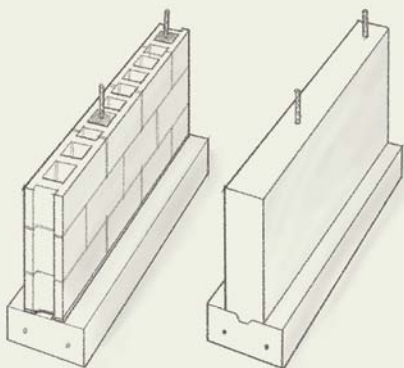
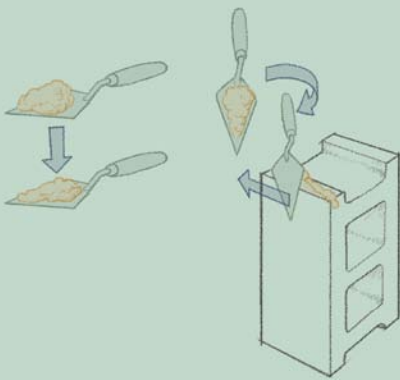
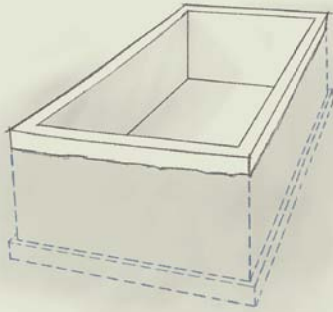

Building Foundations

THE FOUNDATION OF A HOUSE serves two basic functions. First, it protects the rest of the house from the harmful effects of the soil. By holding the frame of the house up off the ground, the foundation keeps it a safe distance from the moisture, frost, termites, mildew, rot-producing fungi, and other organisms that live in the ground.

Second, the foundation serves as a transition from the irregular surface of the land to the level, plumb, and square surfaces of the house. Before the foundation, there is nothing but dirt; after the foundation, there should be a square and plumb structure with a level top. It is upon this flat and even surface that the carpenters begin the frame of the house.

This chapter deals with the challenge of building a foundation that is strong enough to carry the weight of the entire house; tough enough to endure decades of direct contact with the ground; and precise enough to use as a first reference for building the rest of the house.

Assessing and Preparing the Soil

The loads that houses place on soils are, by engineering standards, relatively light. Most building codes, furthermore, are conservative in design. They require wide footings that spread the load of the house, allowing the footings to work in soil that is not ideal. If you carefully follow the provisions of the building code, the soil you encounter on site is usually capable of supporting the house or addition that you are building.

However, problem soils do exist and they require measures that go beyond the general provisions in the building code. Foundations that settle unevenly create out-of-level floors and doors that don't open and close properly.

What to Look for in the Soil

There are a few things you can do to determine if you need to bring in a soils engineer. The first is to look carefully at the soil. Keep an eye on how the soil behaves under load, especially after it rains. These are commonsense observations. If the soil becomes soft and mushy underfoot and trucks and equipment frequently get mired in it, you might have a problem.

Excavating for the foundation The most important person to look to for advice is your building inspector. Building officials are usually familiar with the problem soils in their areas and often know where they are most likely to occur. They can sometimes recognize problem soils simply by looking at them.

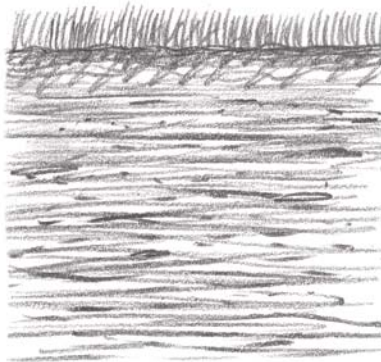

Most problem soils are classified as clay or silt or a combination thereof. The inorganic particles in these soils are very fine—less than 0.003 in. in diameter. When combined with water, clays often become sticky or mushy. When silts dry, they become fluffy; they are sometimes called rock flour.



Coarse sand and rocky soils have excellent load-bearing abilities. If you encounter these soils, however, you need to make sure that they are consistent over the length of the footing. Good, stable soils next to unstable soils can translate into differential movement.

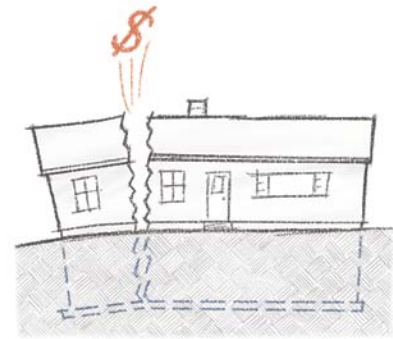

In some extreme cases, houses have been ruined beyond repair by failed foundations.

TOP TIP

Preparing the Soil

.....
 If you encounter problem soil and are required to bring in an engineer, make sure you understand what the engineer recommends and follow those recommendations to the letter. If you and the building inspector find the soil acceptable, you need to follow the requirements of the building code in your area.

Excavation: An Overview

If you're building a basement, the excavation consists of an opening in the ground with a roughly level bottom. This opening has to be a few feet wider and longer than the house. The correct elevation of the bottom of the opening should be determined in advance as outlined in the section on foundation layout on p. 11. As the excavator gets down close to this elevation, you should start checking the elevation of the bottom of the opening. At the same time, check the bottom for levelness. The techniques for measuring the elevation and the levelness of the bottom of the opening are discussed in detail in the section on p. 11 on foundation layout.

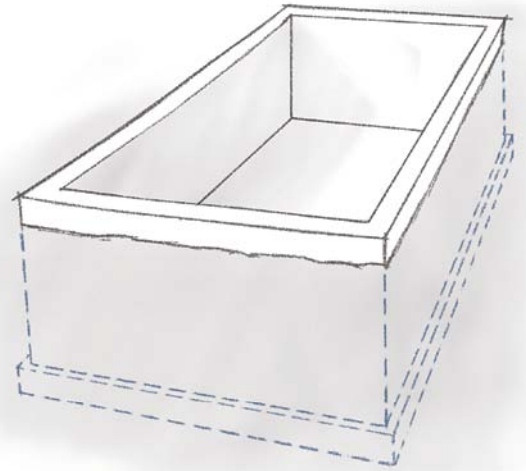

STEP 1 Excavating for the foundation

Monolithic slab: Simply scrape any organic matter off the surface. The bottom should be roughly level.



Crawlspace: Scrape any organic matter off the surface but leave the grade roughly the same as you found it.



Basement excavations: It's important not to go too deep when you dig these foundations.



STEP 2 Digging the footings

1 Building codes require that the bottom of the footing be below the frost line. Wet soil that freezes expands as much as 8%. As it expands, it rises and lifts whatever is on it, including the footings of houses. To avoid frost heave, as it's called, you are required to place the footing below the frost line (the depth to which the ground freezes). This means that in Maine it's often necessary to dig down 48 in. or more, while in Florida a trench 8 in. deep is often sufficient for the footing.

The frost line in Maine is 48 in.

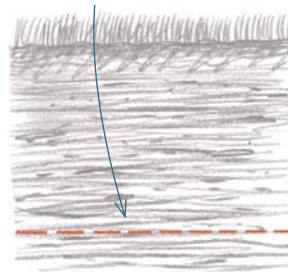

The frost line in Florida is 8 in.

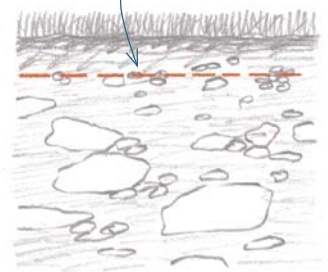

2 It's important to make sure that no sizeable amounts of organic matter remain in the soil after the excavation. Make sure that the footing rests on well-compacted soil. The simplest and surest way to do this is to place the concrete on undisturbed soil. Digging into undisturbed soil loosens it and fluffs it up by as much as 50%. If this disturbed soil is left loose under the footing, the weight of the house eventually compresses it back to its original size. When it does, the footing often cracks.

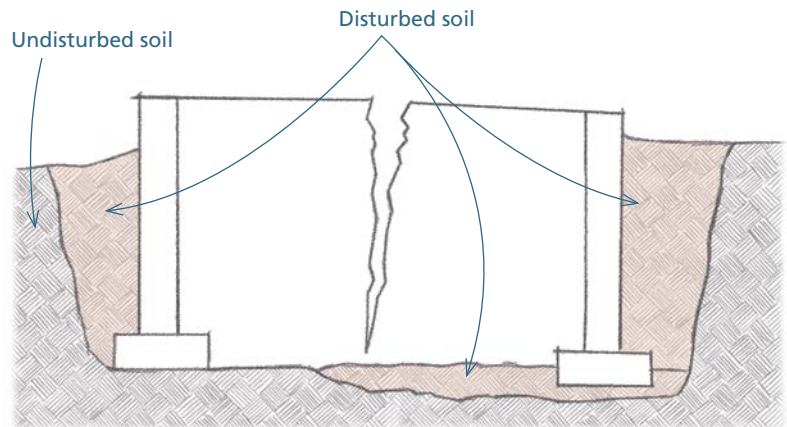
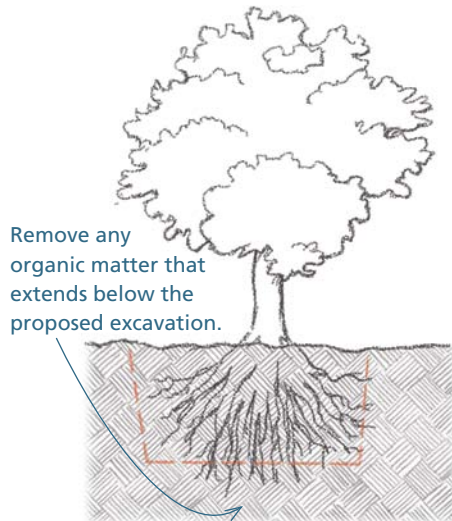

WAYS OF WORKING

Testing the Soil

One unscientific way to test the load-bearing capacity of the soil is to push a steel stake into the ground. Building inspectors often have a T-shaped tool made out of ½-in.-dia. steel rod. To test the soil prior to a footing pour, the inspector leans on the cross of the T and sees how far the upright sinks into the ground. If the steel rod slides into the soil with little resistance, the inspector will require remedial work.

A more objective way to test the soil under the footing is with a penetrometer. A penetrometer is a handheld device that works like a fisherman's scale in reverse. You push the penetrometer in the soil and check the pressure on a calibrated scale. Look for consistent readings along the length of the footing and a bearing value that meets the design load in your area (usually 1,500 lb. to 2,500 lb. per square foot). For soil found to be below that bearing capacity, most jurisdictions require a plan drawn up by an engineer.

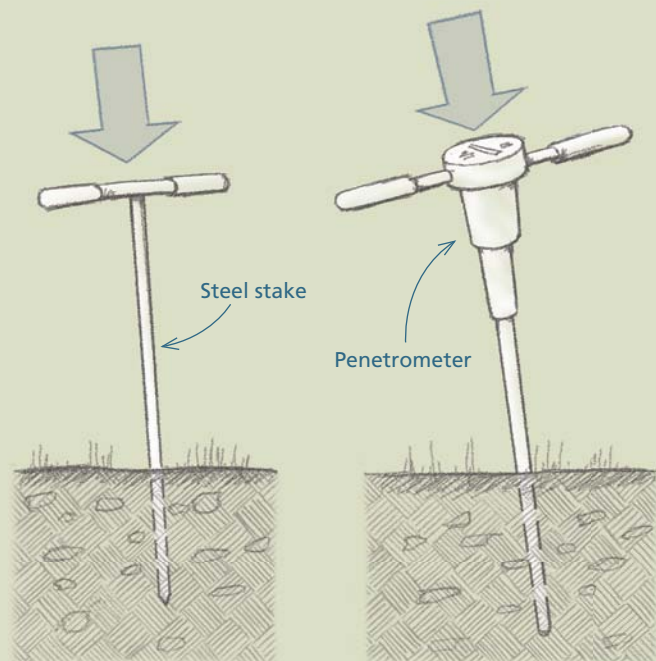

3 To avoid the problems caused by disturbed soil in the footing, clean loose material out of the footing trench with hand tools (square shovels, mattocks, and hoes, for example).

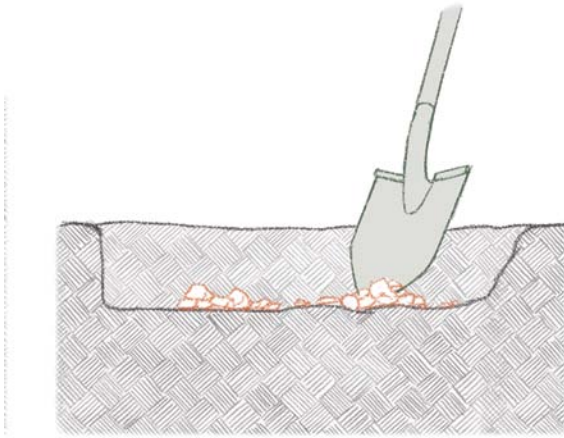

4 Use a jumping jack compactor to reconsolidate the soil, especially in those spots where tree stumps or large rocks have been removed.



For clay or silt, add sand or gravel to the original soil as you reconsolidate the area. Dampen the mixture and place it in 8-in.-deep or less layers as you compact it.

5 Footings spread the load they carry over a broad area. If the weight of the building is concentrated on the edge of the footing, however, it can cause the footing to rotate—just as stepping on the edge of a snowshoe set on top of freshly fallen snow would cause it to tip over.

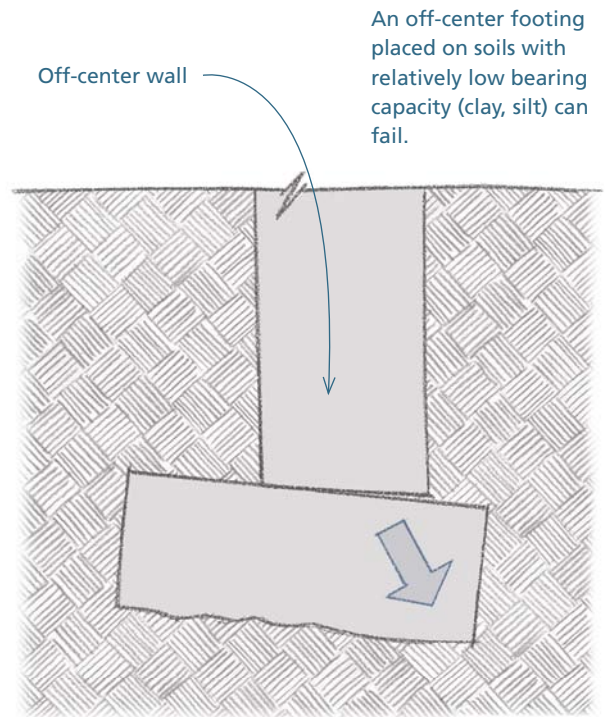
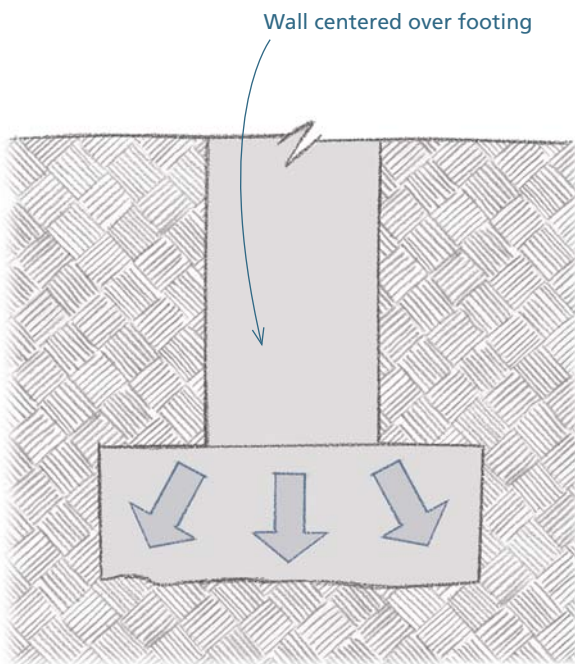

Laying Out Foundations

The general pattern for foundation layout is from the top down. The process begins on the ground, where there are no straight lines, no level surfaces, and no square corners. It's up to you to create these references from scratch. The first step in this process is to set up a leveling instrument to project a level plane above the ground. From this level plane, you establish the elevation of the top of the foundation. All subsequent elevations are then measured down from this top-of-foundation elevation.

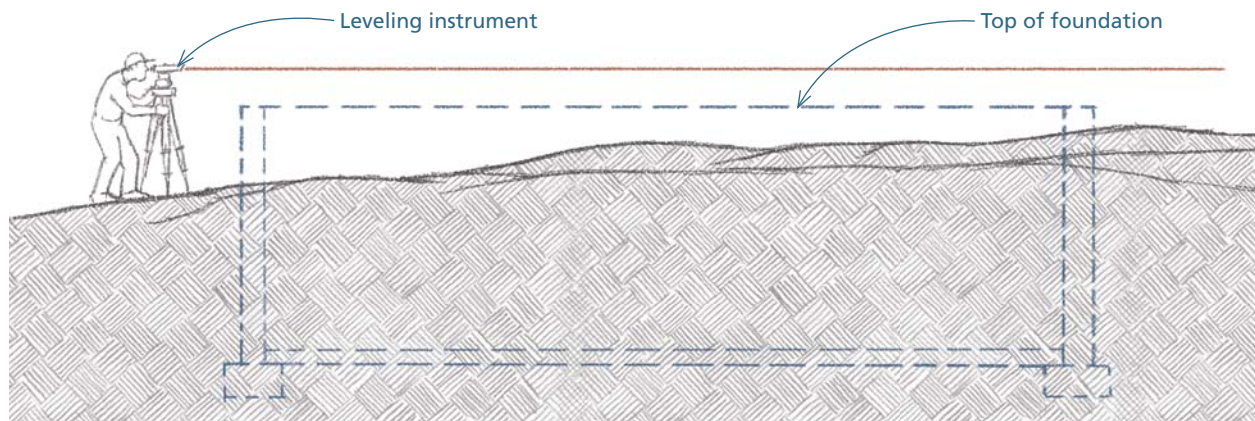

At the top-of-foundation elevation, you can install several batter boards that hold strings within a level plane at that height. You can then use the strings to precisely lay out the positions of the footings and foundation walls in plan view. On some foundations, however, it's easier to excavate the opening for the house, then drop down to the top-of-footing elevation. At that elevation, you can use a combination of batter boards and forms to lay out the precise positions of the footings and walls.

Whether you lay out the footing and walls at the top-of-foundation elevation or at the top-of-footing level, the layout is suspended above the ground. It has to be this way for two reasons. First, the suspended layout establishes the exact elevations of the key components of the foundation. Second, the flat, level plane ensures that the key parts of the foundation are the right size and in the right place. You can't execute a precise layout on the ground; the sloped and uneven surface will distort the dimensions and render them inexact.

The following section uses two examples to show how to lay out two different kinds of foundations. The designs presented here are common; however, some of the details might not be accepted where you live. Check with your local building officials to find out what's needed in your area. Although specific examples are used here, the basic procedures can be adapted to just about any foundation.

TOP TIP

It's Essential Not to Overexcavate

.....
Digging too deep, then putting dirt back in the opening compromises the integrity of the soil under the footings. To avoid overexcavating, check the bottom of the opening with increasing frequency as you get closer to the desired elevation.
.....

Laying Out a Basement Foundation

In this example, the foundation is a 38-ft. by 30-ft. basement that projects about 30 in. above the highest point of the surrounding grade. The corners of the house have been roughly marked with stakes and the elevation established as 30 in. above one of the stakes. The first thing you have to do is guide the excavator through the excavation of the opening for the foundation. In this phase of the layout, make sure the excavator digs in the right place, gets the opening the correct size, and makes the bottom level and at the correct height. It is upon the roughly level surface at the bottom of the excavation that you'll lay out the footing and the foundation walls.

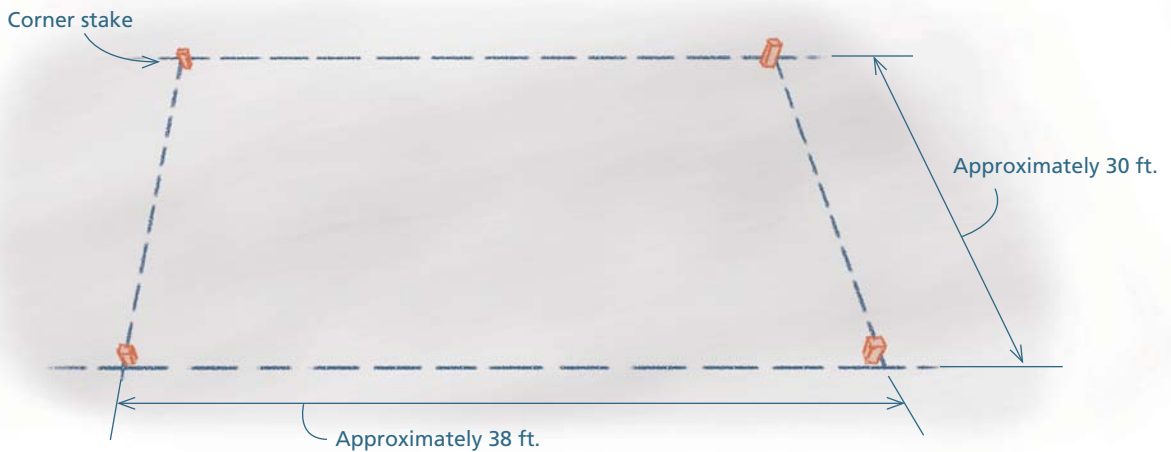

WAYS OF WORKING

Getting the Grade Right

For the final grade around a house, most building codes require that at least 8 in. of the foundation extend out of the ground and that the soil slope away from the foundation a minimum of 6 in. within the first 10 ft. To achieve this minimum standard on the uphill side of the foundation, measure the elevation 10 ft. uphill from the planned foundation wall and set the elevation of the top of the foundation at least 14 in. higher than the elevation at that point. Later, when you backfill around the foundation, you'll have enough elevation to form the required grade on the uphill side. Leaving the foundation higher than this minimum standard allows you to increase the grade and hold the house up even higher out of the ground.

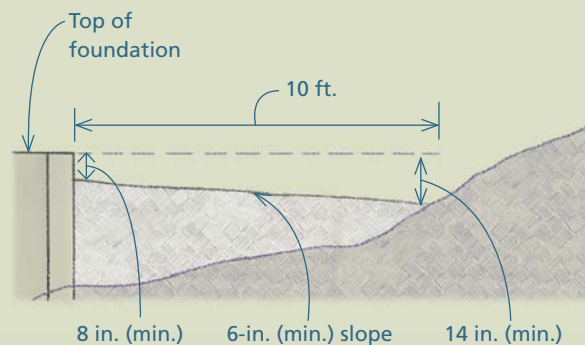

STEP 1 Record the preliminary layout

1 When the excavator digs the oversized opening for the basement, the stakes marking the corners of the house will be obliterated. To preserve the layout, set up a line that extends over the corners of the house, then drive offset stakes into the ground along that line. Place the offset stakes a set distance away from the original corner stakes. A 10-ft. offset is common because it's a safe distance away from the excavation and it's an easy distance to remember. The offset stakes should be in line with the long walls (the 38-ft. walls, in this example).

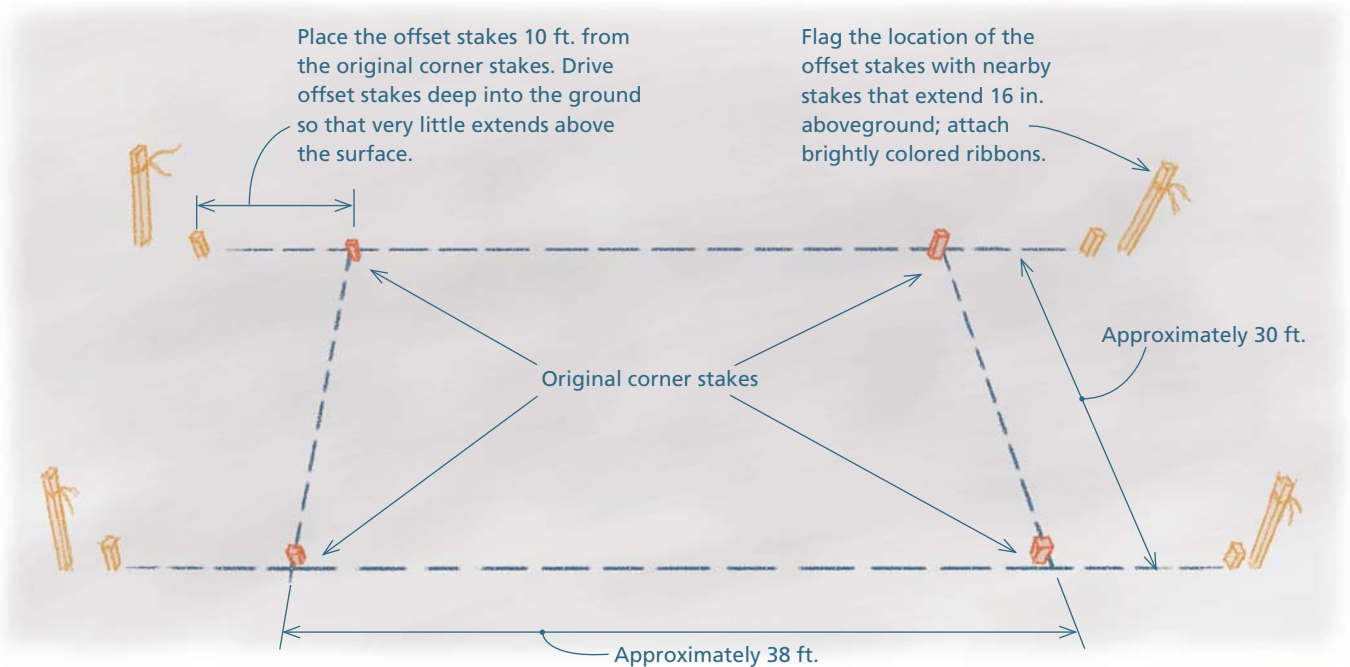

2 Record the elevation of the foundation. In this case, the desired elevation for the top of the foundation is 30 in. above the highest corner stake. Using a leveling instrument, measure the difference in elevation between the top of the corner stake and the top of the nearest offset stake. (See "Using a Leveling Instrument" on p. 14.)

In this example, the bench mark stake is 6 in. higher than the corner stake.

The top of the foundation is 30 in. above the corner stake.

The top of the foundation, therefore, should be 24 in. above the top of the bench mark stake.

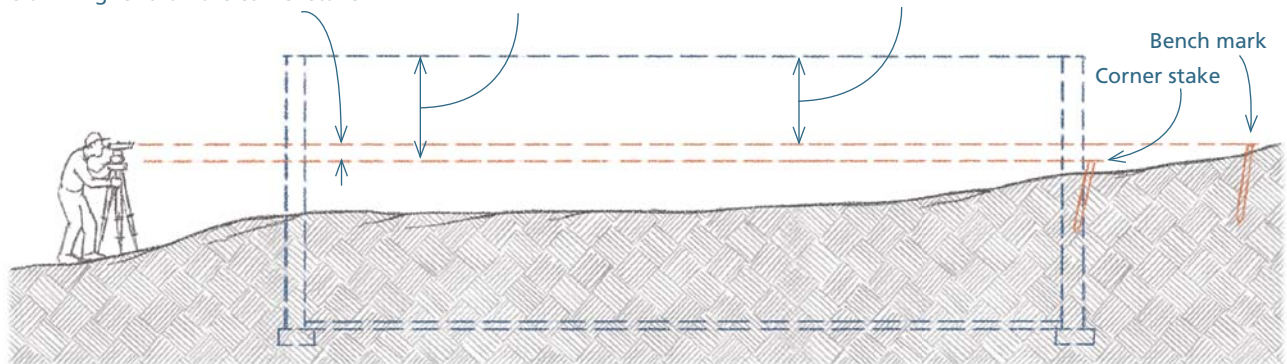

Using a Leveling Instrument

There are two basic kinds of leveling instruments commonly used by builders: optical levels (also called sight or telescopic levels) and laser levels. Both of these kinds of levels come in many forms and are capable of doing numerous measuring tasks. They share one feature in common, however; they all project a level line and a level plane. For most residential builders, this basic feature is the most important role of these tools.



● ESTABLISHING A LEVEL PLANE

Different leveling instruments project a level plane in different ways.

An optical tool provides a level line of sight. Swiveling the tool horizontally establishes a level plane.

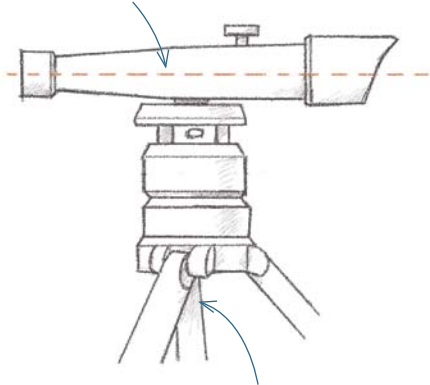

Most leveling instruments can be mounted on a tripod.

A laser level that projects a single level line works the same way as an optical level; swiveling it establishes a level plane.

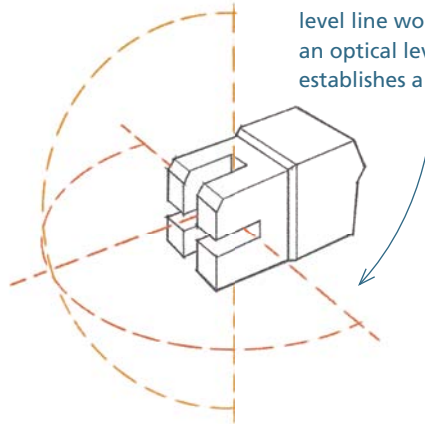

Many self-adjusting lasers have flat bottoms and can be set on any reasonably flat surface.

Lasers can also project a level plane that radiates in all directions from the instrument.

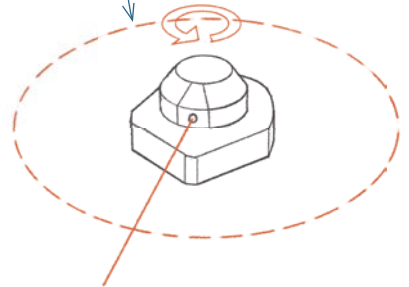

● MEASURING TO THE LEVEL PLANE

You can measure the grade of the land, establish the elevation of key foundation components, set forms precisely level, and do many other layout tasks by measuring to the level plane projected by a leveling instrument.

A sighting rod, a large measuring stick that's marked off in feet and inches, is used to determine the measurement. A tape measure, carpenter's rule, large measuring stick, or simply a strip of wood can serve the same purpose.

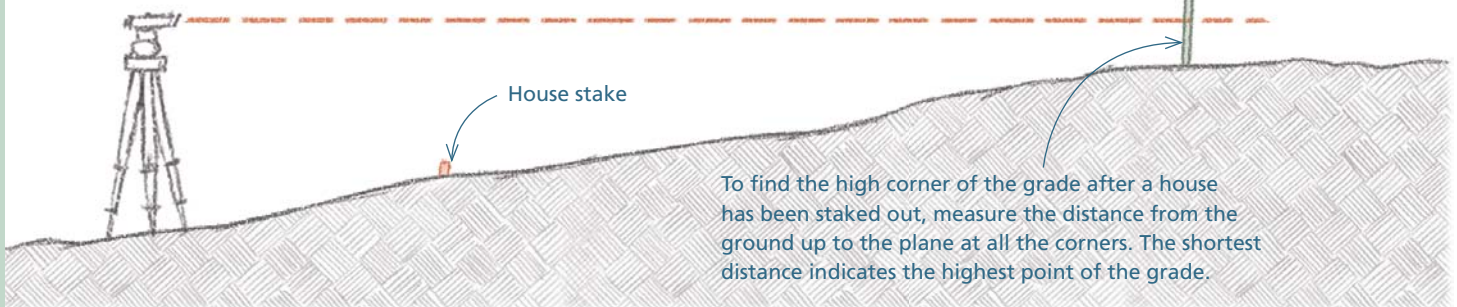

To find the high corner of the grade after a house has been staked out, measure the distance from the ground up to the plane at all the corners. The shortest distance indicates the highest point of the grade.

● FINDING AND USING THE “DIFFERENCE IN ELEVATION”

Key elevations are often established in relation to a single reference called a bench mark. Once you know this dimension, you can quickly compute the other critical elevations.

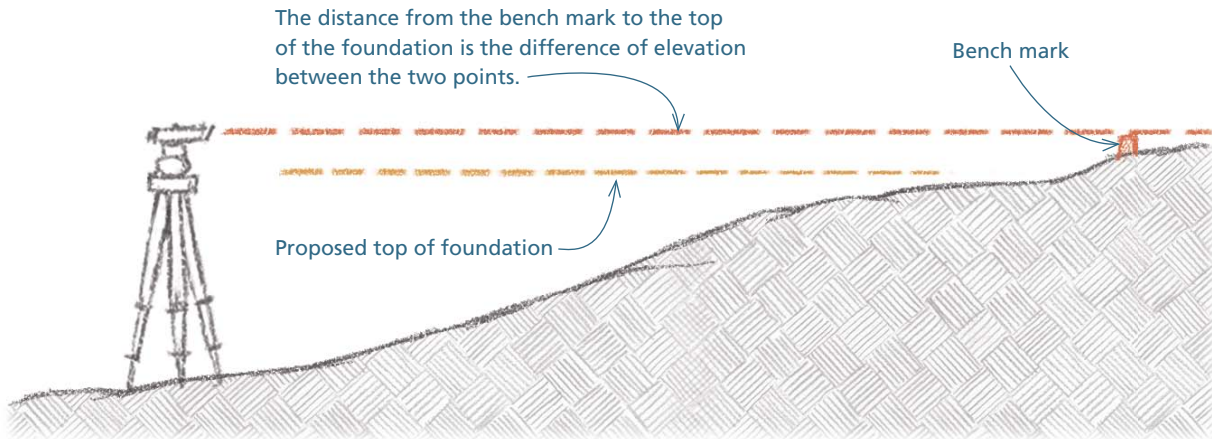

● RESETTING THE LEVEL

The difference in elevation between the bench mark and any critical elevation of the foundation is constant. The elevation of the plane projected by the instrument, however, changes when the instrument is repositioned.

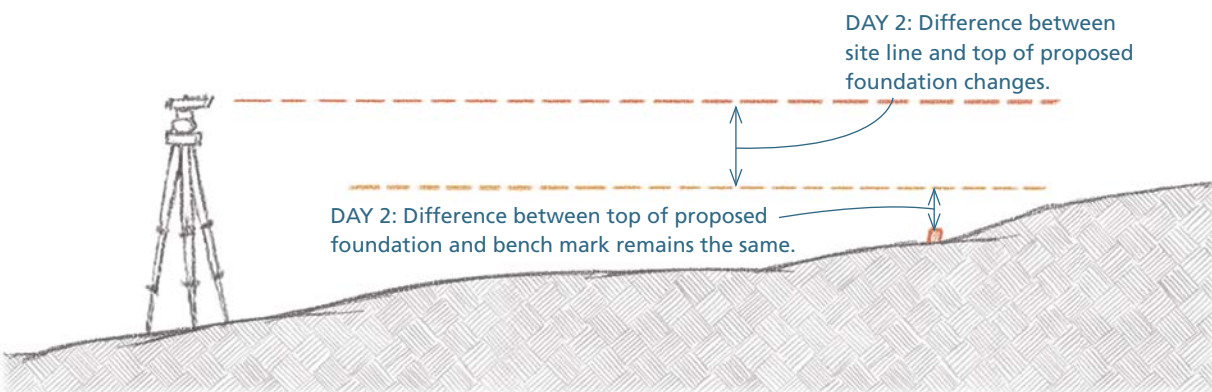
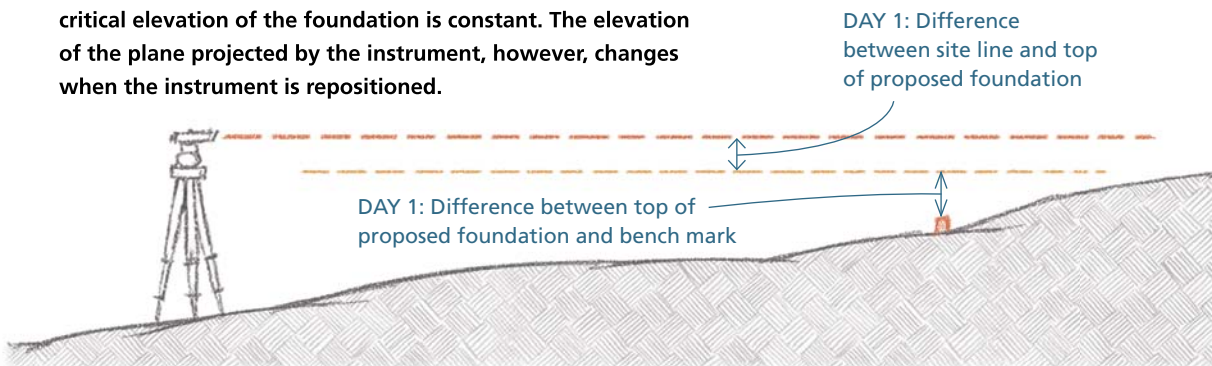

STEP 2 Mark and dig the opening

1 Stretch strings between the corner stakes and mark the ground about 4 ft. outside of the strings. You can use a 4-ft. level as a gauge to measure the distance from the string. To mark the line, use lime or dry masonry mortar poured from a paper cup or use brightly colored spray paint.

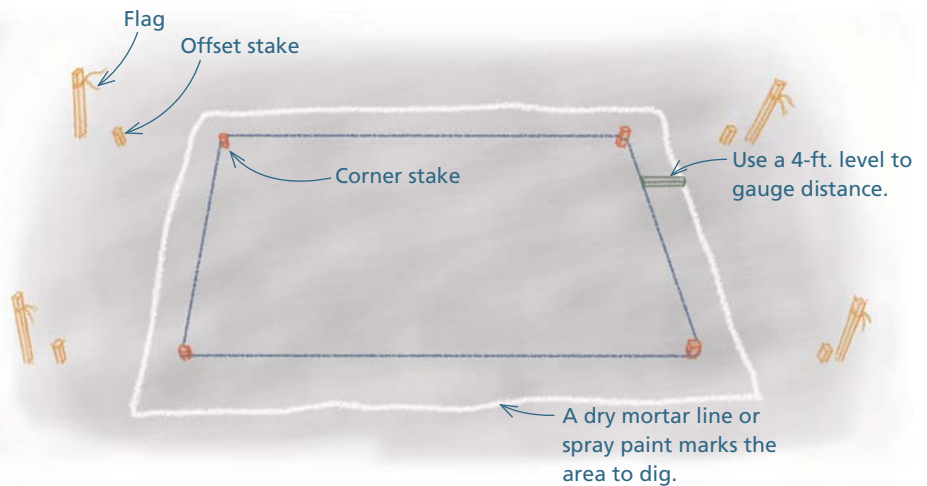

2 Before you begin digging, establish the exact distance that you need to dig below the bench mark. This requires that you know the design of the foundation, including the exact heights of the materials that you're going to use.

Make all measurements from the same reference: the targeted top-of-foundation elevation. In this example, the top of foundation elevation has been established at 24 in. above the bench mark.

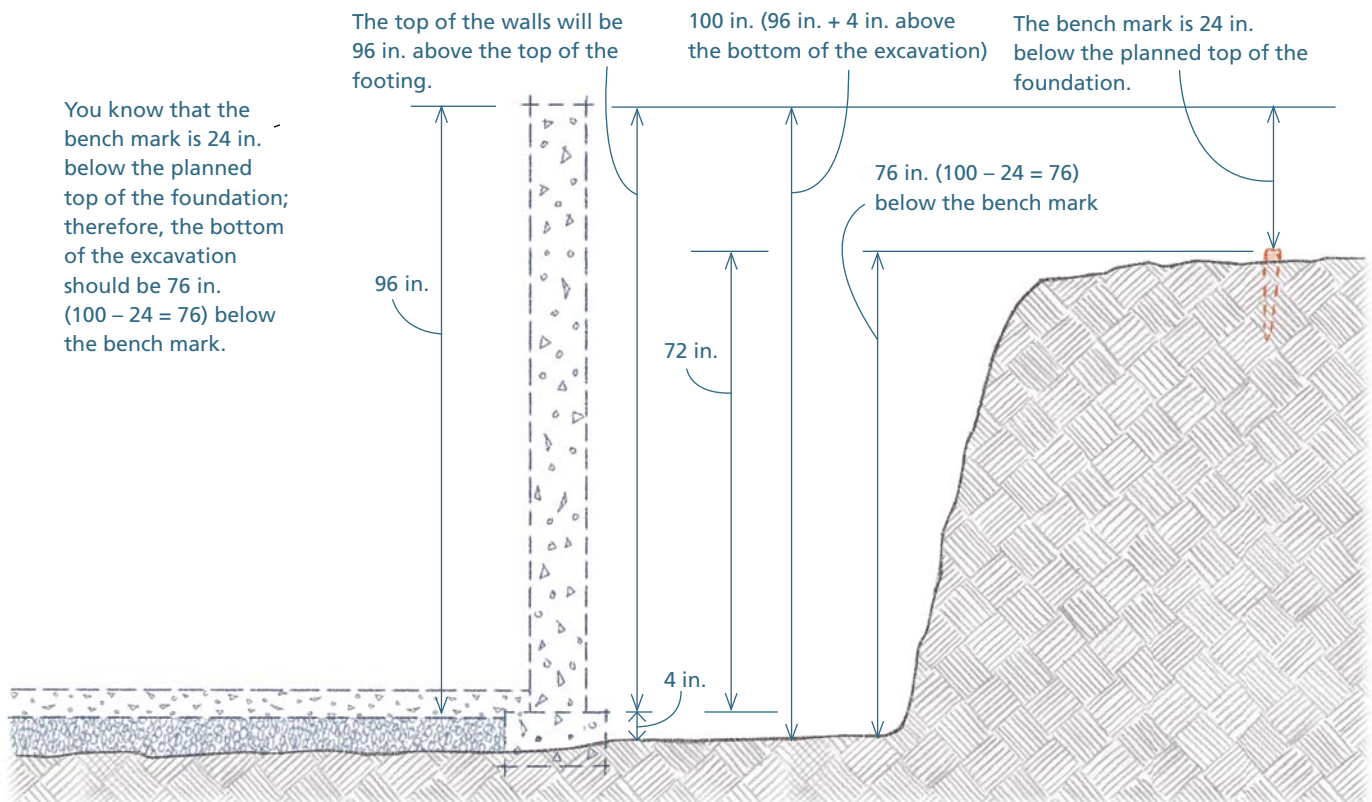

3 Set up a leveling instrument outside of the opening. After leveling the instrument, measure the height that it reads above the bench mark (here, 14 in.). Add this amount to 76 in. The total, 90 in., is the distance from the level line projected by the instrument to the bottom of the excavation.

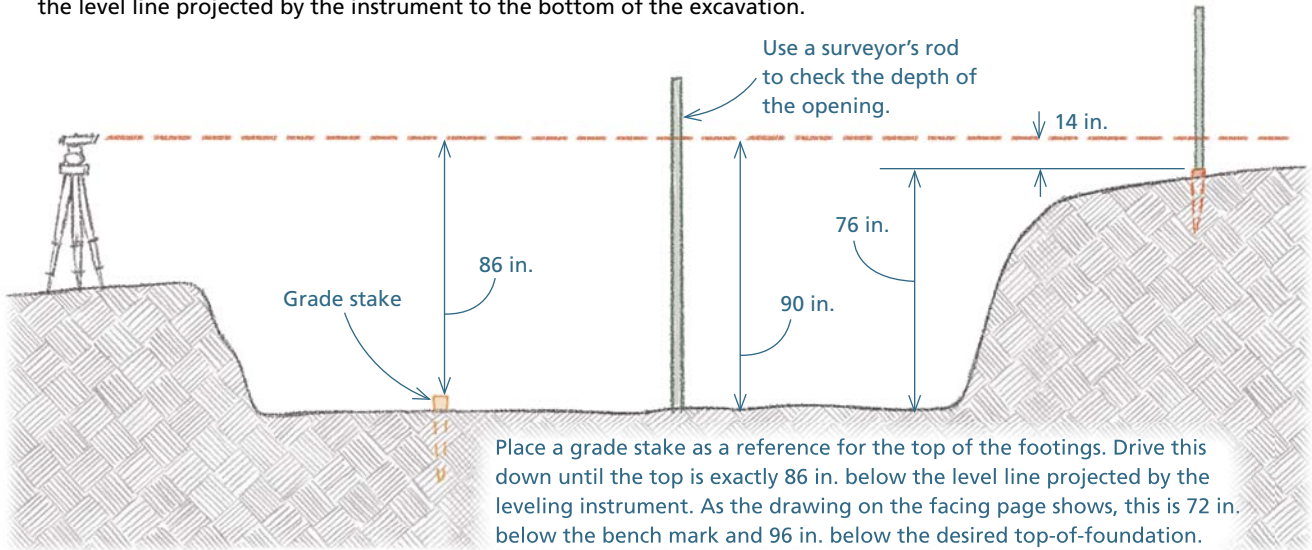

STEP 3 Lay out the first wall

EXAMPLE 1 assumes that you removed the instrument at the end of the excavation and have returned the next day to lay out the footings.

1 Pull a string from one offset stake to the other along either of the long walls.

2 Near each side of the excavation, drive in a pair of stakes, with the string above roughly centered between them. Leave about 8 in. of the stakes above the bottom of the excavation.

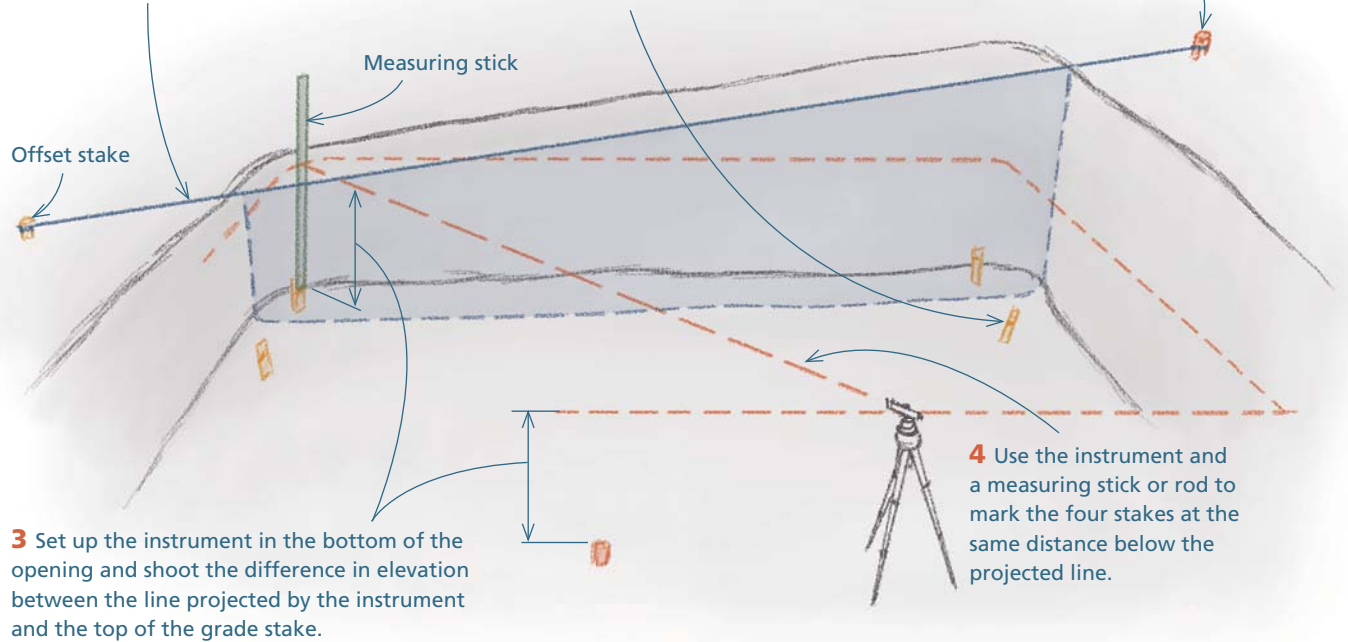

EXAMPLE 2 assumes that you did not set a grade stake just after the excavation.

1 Set up the instrument outside the opening and shoot a level line anywhere above the bench mark.

2 The difference in elevation between the bench mark and the line projected by the instrument is 11 in.

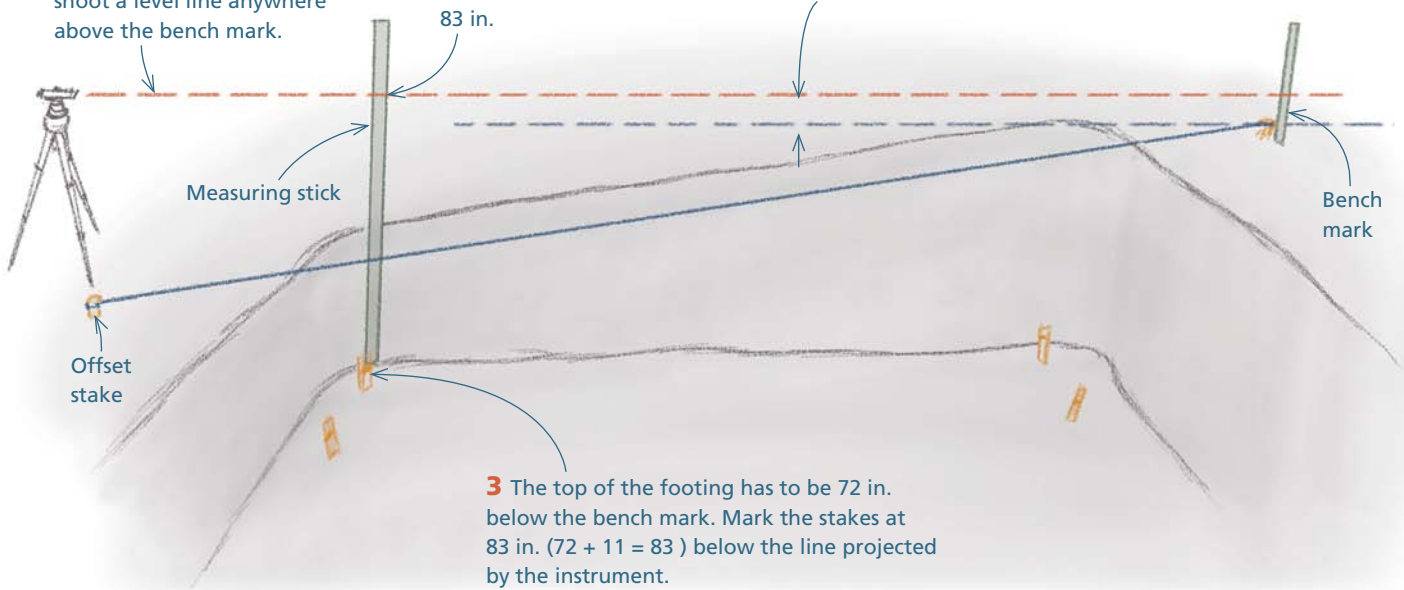

4 Once you have the four stakes marked, attach a horizontal batter board between each pair of stakes, with the tops of the boards even with the marks.

The batter board should be level, exactly 72 in. below the bench mark, and cross directly below the string that represents the wall.

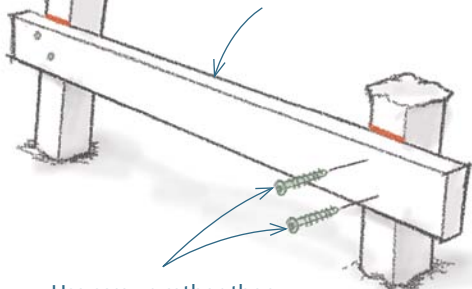

Use screws rather than nails to avoid jostling the stakes out of position.

5 Transfer the exact location of the string down to the batter boards.

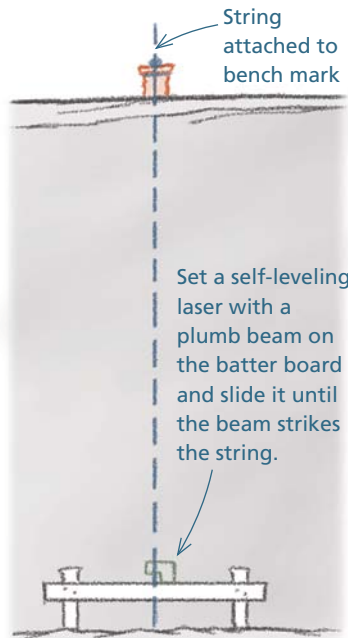

You also could use a 6-ft. spirit level or a plumb bob to transfer this location.

6 After marking both batter boards, set a string from one mark to the other. The string is set at the desired elevation for the top of the footing.

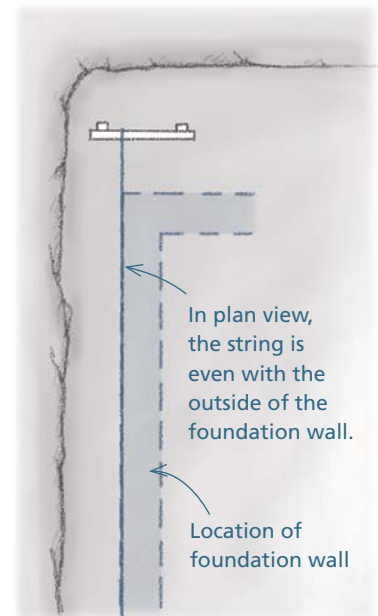

ESSENTIAL SKILLS

Working with Right Triangles

A right triangle has one side perpendicular to another. This property allows you to use the geometry of a right triangle to quickly lay out 90° angles.

The Pythagorean Theorem is a 2,500-year-old formula for finding the hypotenuse (the unknown measurement) of a right triangle. The formula can be written: Hypotenuse = $\sqrt{\text{Altitude}^2 + \text{Base}^2}$ or $H = \sqrt{A^2 + B^2}$.

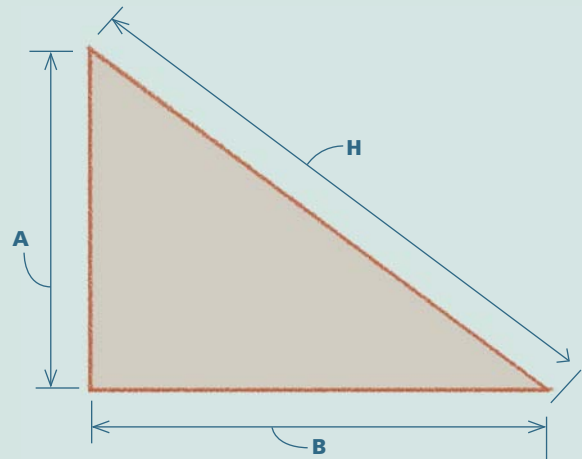

• THE PYTHAGOREAN THEOREM IN USE:

If you have a triangle with an **Altitude** of 12 and a **Base** of 16, the math goes like this:

$$\begin{aligned} H &= \sqrt{12^2 + 16^2} \\ &= \sqrt{144 + 256} \\ &= \sqrt{400} \\ &= 20 \end{aligned}$$

• EXPANDING AND CONTRACTING RIGHT TRIANGLES

You can expand or contract any right triangle without changing its angles by multiplying or dividing all three sides by the same number. If you divide all three sides of the triangle just discussed by 4, for example, you end up with a 3-4-5 triangle that retains the exact same angles:

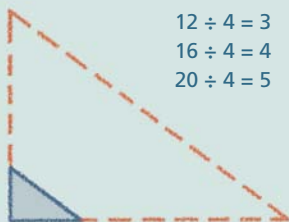

$$\begin{aligned} 12 \div 4 &= 3 \\ 16 \div 4 &= 4 \\ 20 \div 4 &= 5 \end{aligned}$$

To shrink this 3-4-5 triangle to a triangle with a base of 1, divide all three sides by 4:

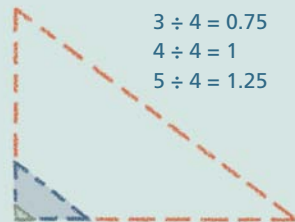

$$\begin{aligned} 3 \div 4 &= 0.75 \\ 4 \div 4 &= 1 \\ 5 \div 4 &= 1.25 \end{aligned}$$

To expand this 0.75-1-1.25 triangle back to a triangle with a base of 16, multiply all three sides by 16:

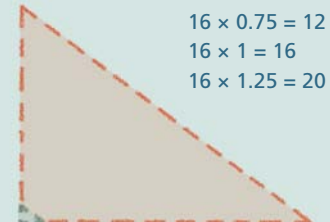

$$\begin{aligned} 16 \times 0.75 &= 12 \\ 16 \times 1 &= 16 \\ 16 \times 1.25 &= 20 \end{aligned}$$

• LAYING OUT ACUTE AND OBTUSE ANGLES

In addition to laying out a perpendicular line, you can use the geometry of a right triangle to lay out obtuse and acute angles. To lay out a 45° turn in a 30-ft.-wide foundation, for example, set up parallel lines 30 ft. apart. Calculate the hypotenuse of a right triangle with two sides of 30 ft.:

$$\sqrt{2} \times 30 = 42.42$$

Pull the 42.42-ft. dimension from a fixed point on one line to the other and mark that point. A line drawn through these points runs at a 45° angle from the other lines.

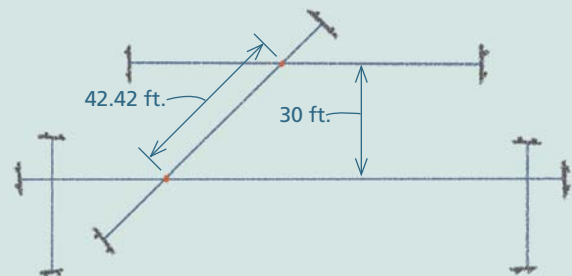

STEP 4 Lay out the other long wall

1 Measure 30 ft. from the first string set up in step 3, and drive a pair of stakes at each end to straddle the 30-ft. measurement.

3 Attach batter boards with the top edge even with the marks.

2 Use the leveling instrument to mark the stakes at the same elevation as the first two pairs of stakes (i.e., 72 in. below the bench mark).

4 Adjust the position of the string along the batter boards until it's exactly 30 ft. away from and parallel to the first string.

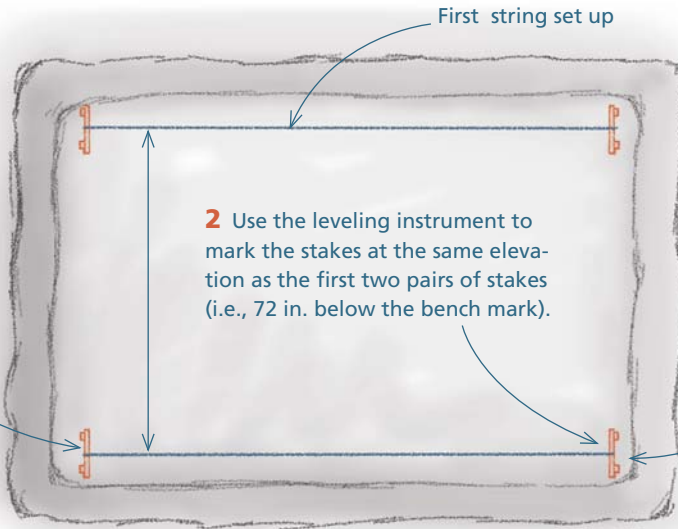

Plan view of excavation

STEP 5 Lay out the corners of the foundation

1 Mark the offset stake string at 10 ft. to establish the first corner mark.

3 Measure and mark the length of the foundation wall (38 ft.) along the lower string.

5 Pull a tape from the 38-ft. mark diagonally until the tape reads 48 ft. 5 in.

6 Repeat step 4 to locate the last corner.

Offset stake

2 Plumb down to the lower string and mark the location on the foundation wall string below.

4 Use the Pythagorean Theorem, as described on p. 19, to determine the hypotenuse of a right triangle with sides of 38 ft. and 30 ft. This comes to 48 ft. 5 in.

7 The distance between the two marks on the second string should be 38 ft.

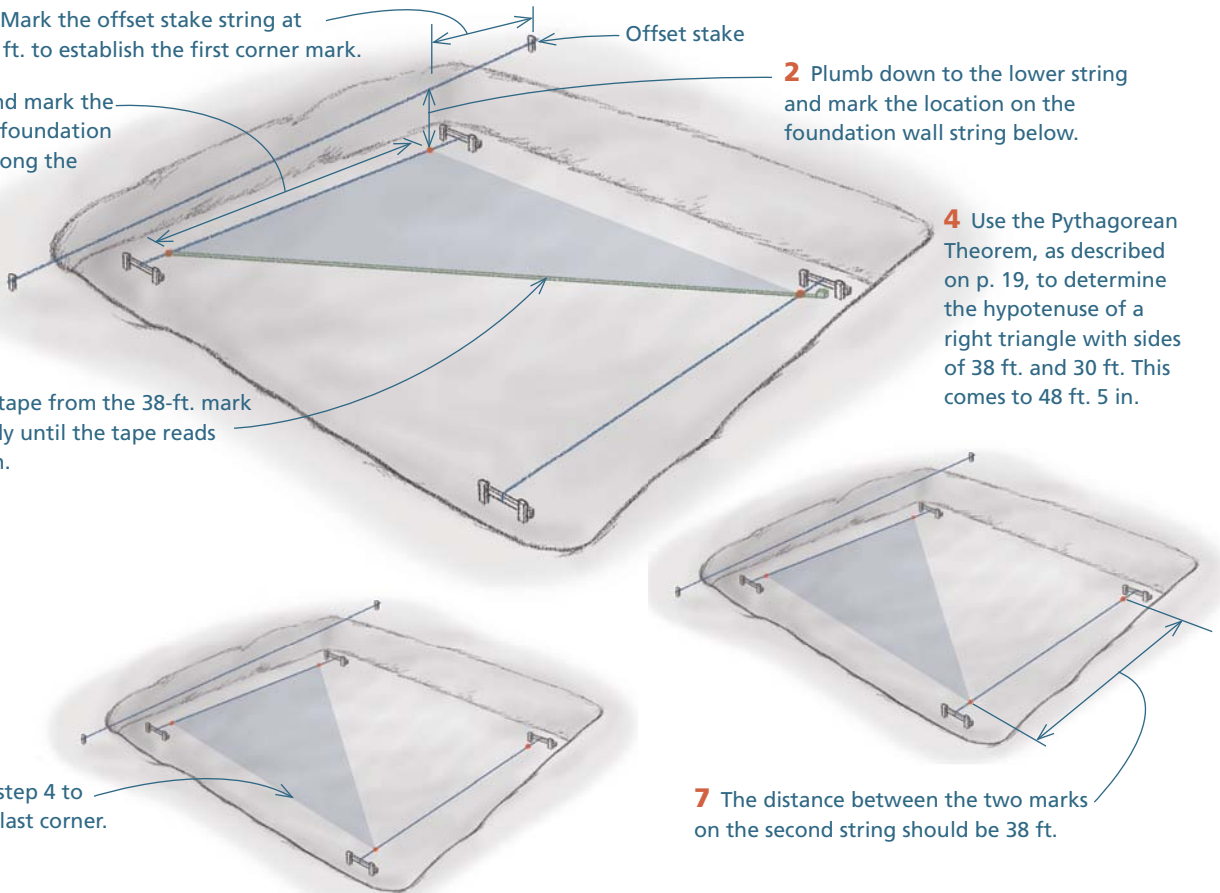

STEP 6 Form the footing

1 Mark the batter boards 4 in. outside of the strings that represent the outside of the foundation wall.

2 Attach lines that run from one mark to the other.

3 Place 2x4 forms $\frac{1}{8}$ in. away from the string. Place stakes outside of the form. The top of the form should be even with the string.

5 Measure 4 in. from the sidewall strings and mark the location of the outside of the footings for the two side walls, then run strings between the marks.

4 To mark locations for the side walls on the forms, set strings that extend across the opening from one of the form boards to the other so the strings cross over the corner marks you made on the long wall strings.

6 Place forms along the strings.

Make sure that the positions of the strings that represent the foundation walls are clearly marked on the forms.

7 On the forms, measure and mark 12 in. in from the strings representing the outside walls of the foundation. These measurements mark the inside of the footings.

On many houses, the plans specify footings for piers (or posts). If these are specified, carefully measure from the strings that represent the walls to lay out the exact positions of the pier footings. Form the pier footings with 2x4s at the same height as the perimeter footings.

8 Build a form along the inside of these lines to complete the perimeter footing forms.

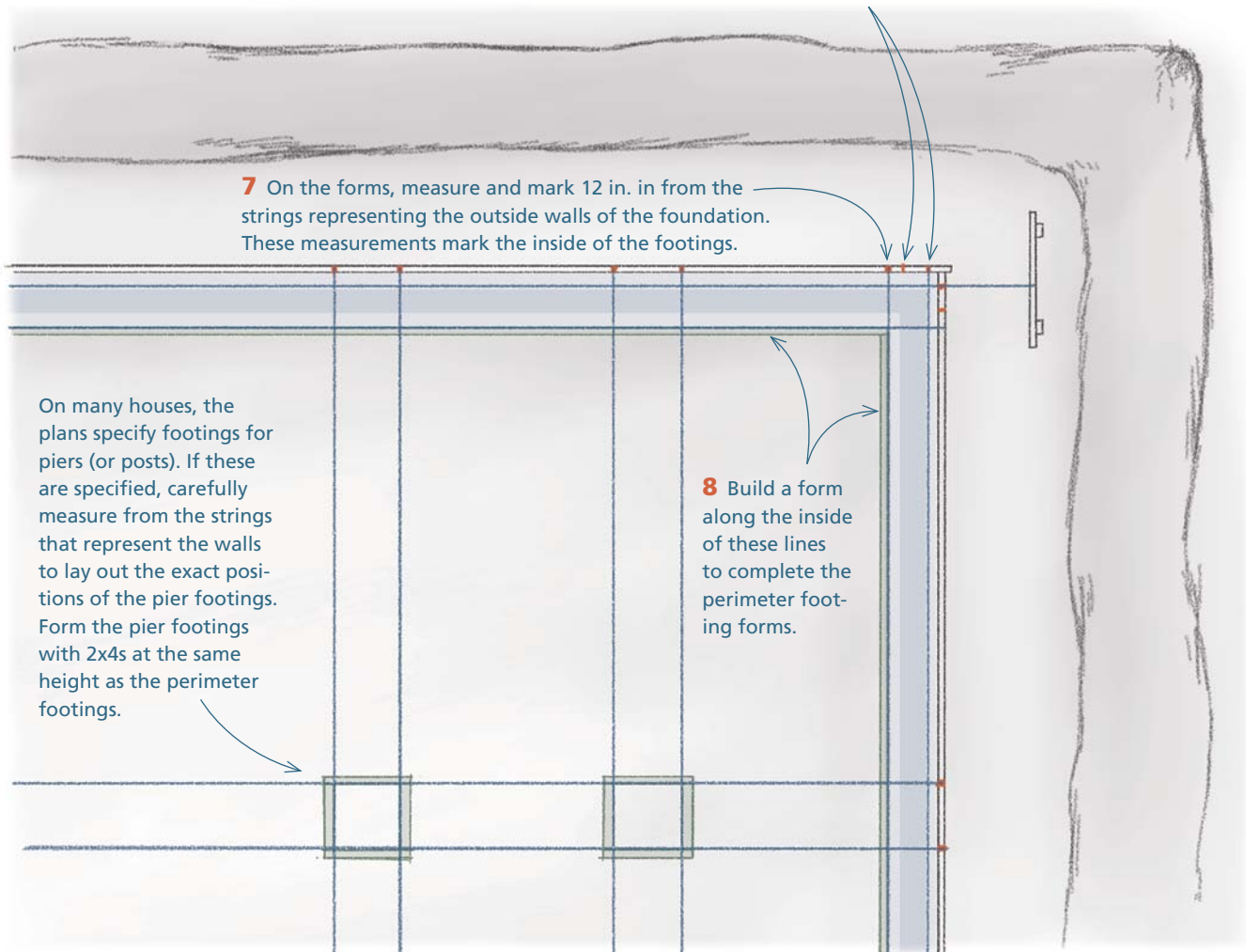

STEP 7 Dig the footings

Remove the strings and dig the footing between the forms with a square shovel. Make the bottom of the footing 8 in. from the top of the form. The bottom of the trench should be flat and consist of undisturbed soil, and the sides should extend straight down from the forms.

To measure the depth, place a straightedge across the form and measure to its bottom edge.

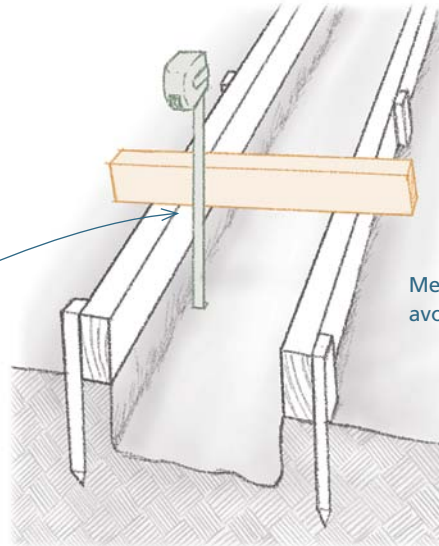

Measure frequently to avoid overdigging.

STEP 8 Prepare for the footing pour

Install steel as required by your local code and by the specifications on your plan. Check with the plumber and septic system subcontractor for possible pipe placement and any pipes or sleeves in the form. If a sump pump is needed, place the pipe through the form.

In most jurisdictions, you're required to have the footing examined by the building inspector at this point. Once you get the go-ahead from the inspector, calculate the volume of concrete needed and schedule a delivery. (There will be information on estimating concrete quantities in the next section.)

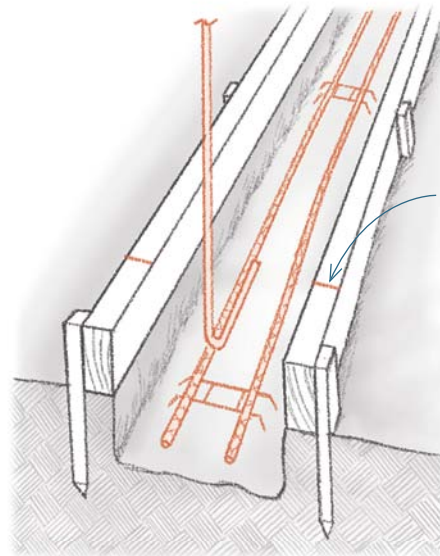

Place vertical pieces of steel precisely by measuring and marking directly on the forms.

STEP 9 Pour the footing

Pour the concrete and strike it even with the top of the form. Form a keyway in the footing, if your foundation plan calls for one.

Place strips of wood in the wet concrete just after you've placed the concrete to mold the keyways.

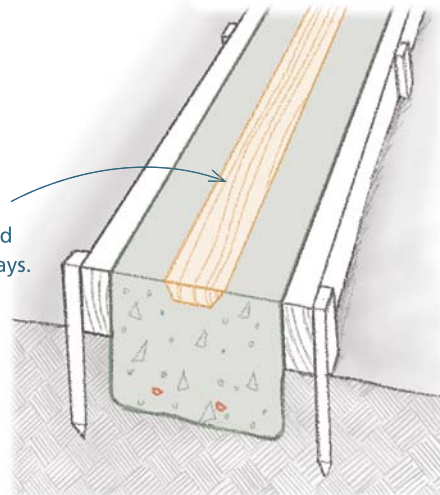

STEP 10 Lay out the walls

A few days after pouring the footings, you can lay out the foundation walls on the hardened concrete. The top of the concrete should be level and at the correct elevation. The locations of the walls are recorded on the forms.

Once you've determined that the layout is precisely correct, you can build 96-in.-tall walls from poured concrete, concrete block, or insulated concrete forms. Any of these wall systems would bring the foundation up to the targeted elevation.

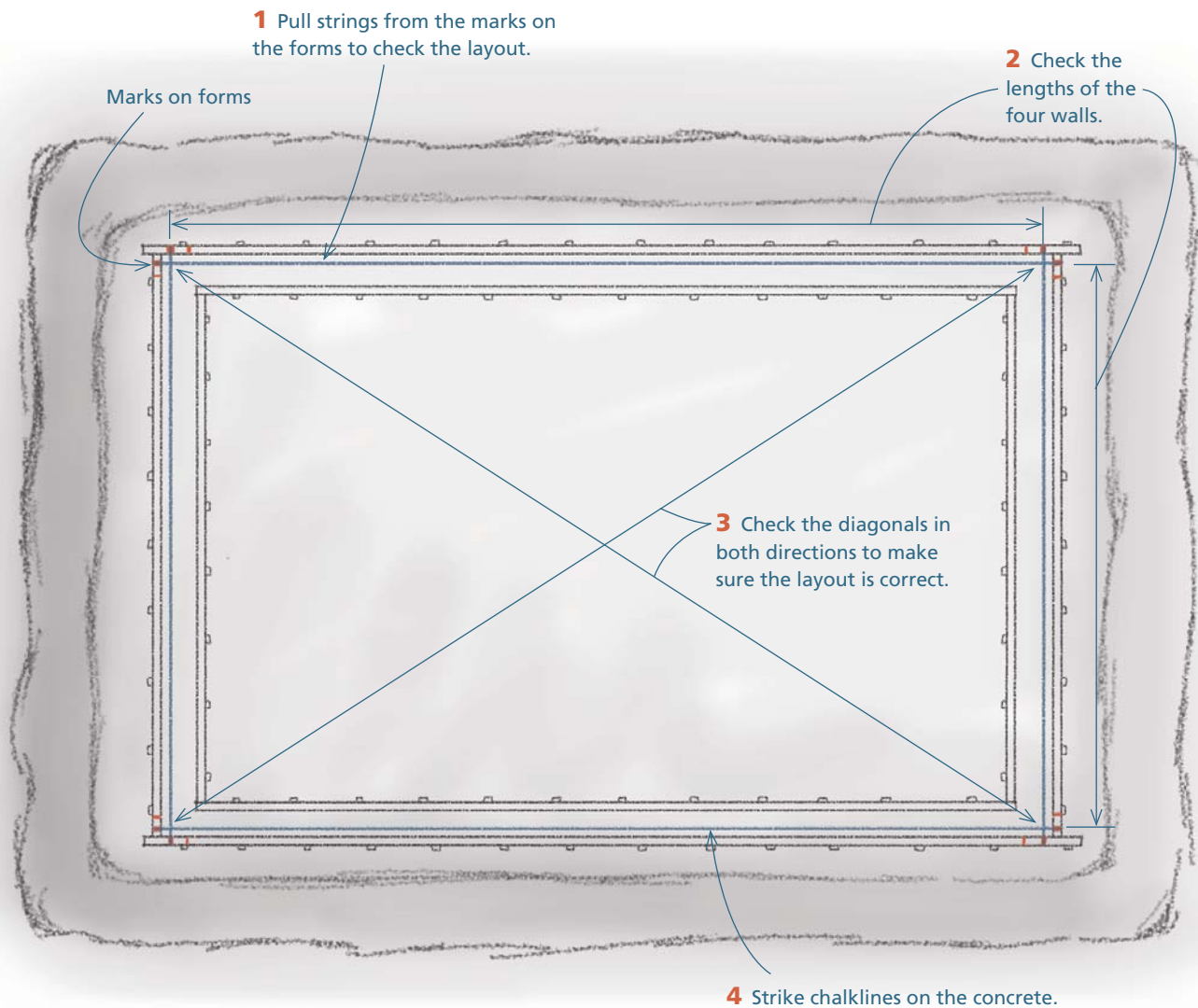

In cold climates, part of the footing may have to be dug deeper than 8 in. If you're planning a walk-out basement door, the footing under and near the door may have to be stepped down to get it below the frost line. Check with your building inspector to see what you need.

Setting Up a Line Quickly and Accurately

Because builders use stringlines extensively for concrete, masonry, and carpentry layout, it's important to learn how to set one up quickly and accurately. Lines generally need to be drawn tightly to remove sag, so it's usually necessary to attach them securely.

● ANCHORING THE LINE TO WOOD SURFACES

When you have a wood surface, it's often possible to drive a nail halfway into the surface, then tie the line off to the nail.

Method One

1 Loop the string around your index finger, and twirl your finger several times.

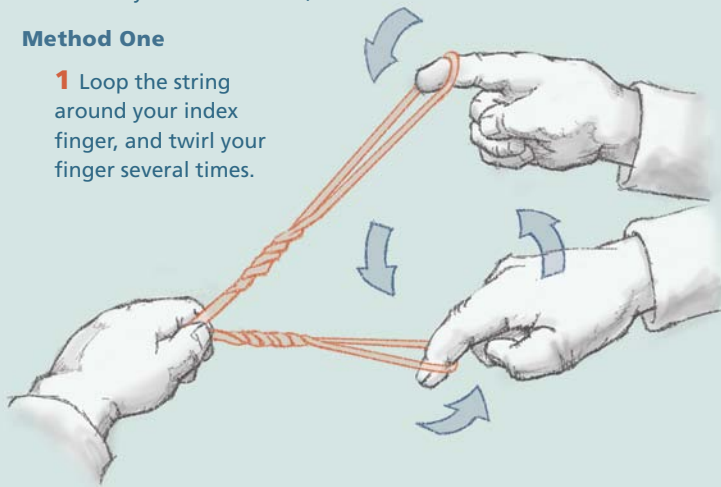

2 Hook the loop over the nail.

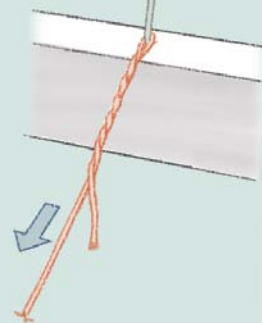

3 Pull the loose end of the string one way and the taut end the other.

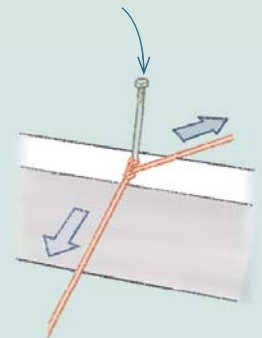

Method Two

1 Loop the string around your thumb and forefinger.

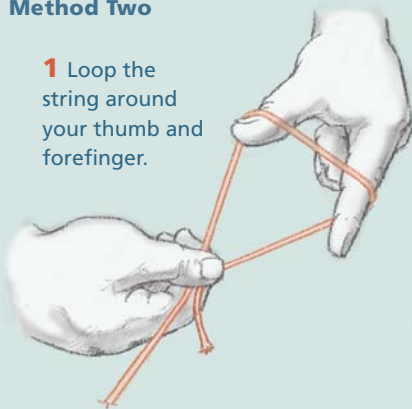

2 Turn your hand down to create two loops.

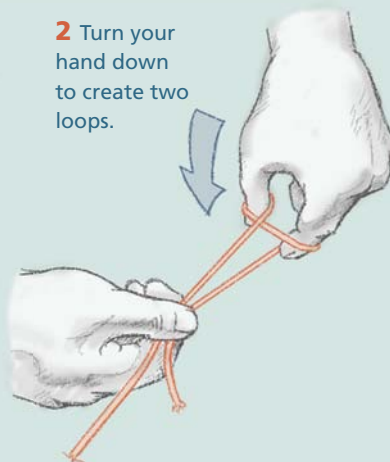

3 Slip the loops over the nail and pull the string tight.

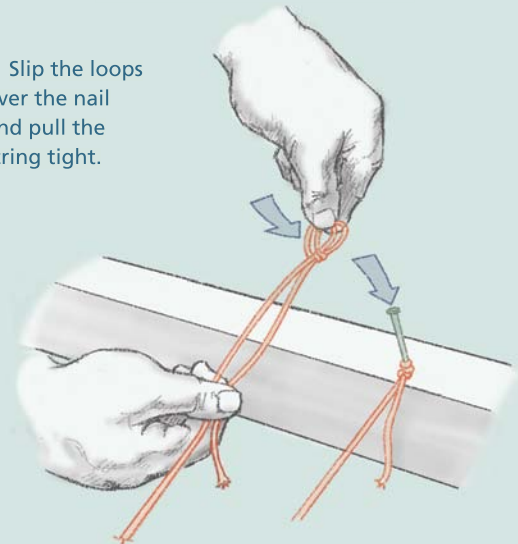

• LINE BLOCKS

Line blocks allow you to secure a line without using nails. This has a few advantages: You can attach the string to finished surfaces without making a nail hole; you can secure the string to concrete and masonry surfaces; and you can adjust the position of the line easily.

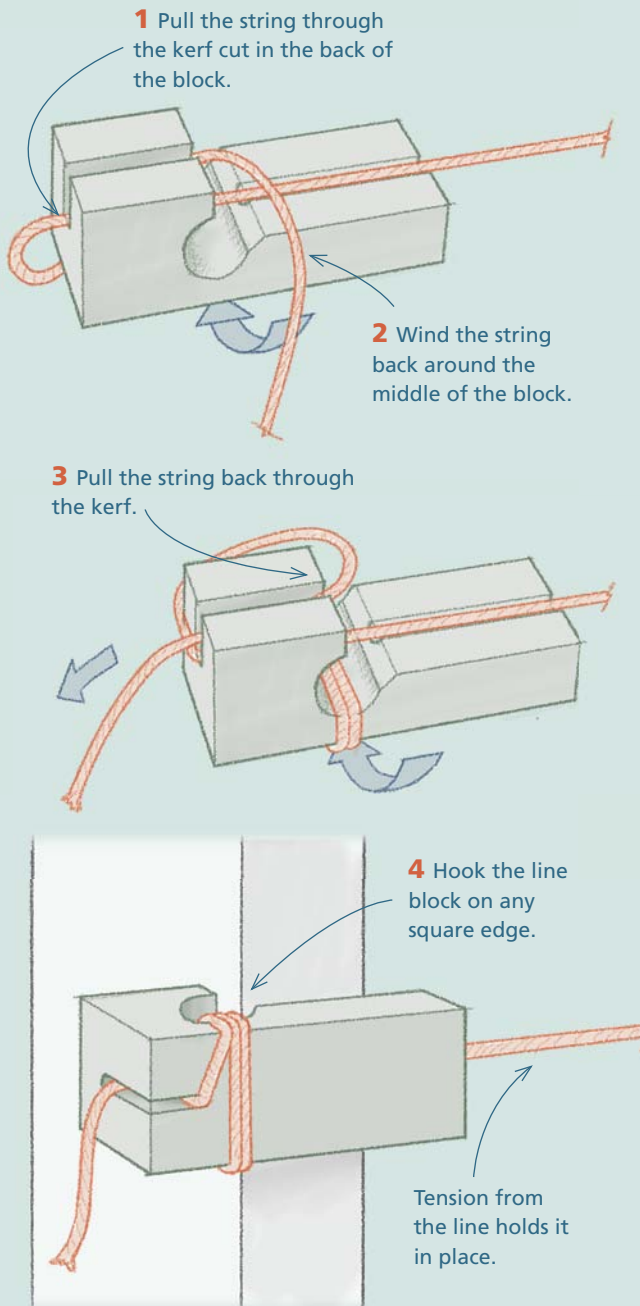

• LAYING OUT ONE LINE PARALLEL TO ANOTHER

To lay out one line parallel to and a set distance away from another, use a pair of batter boards for each line.

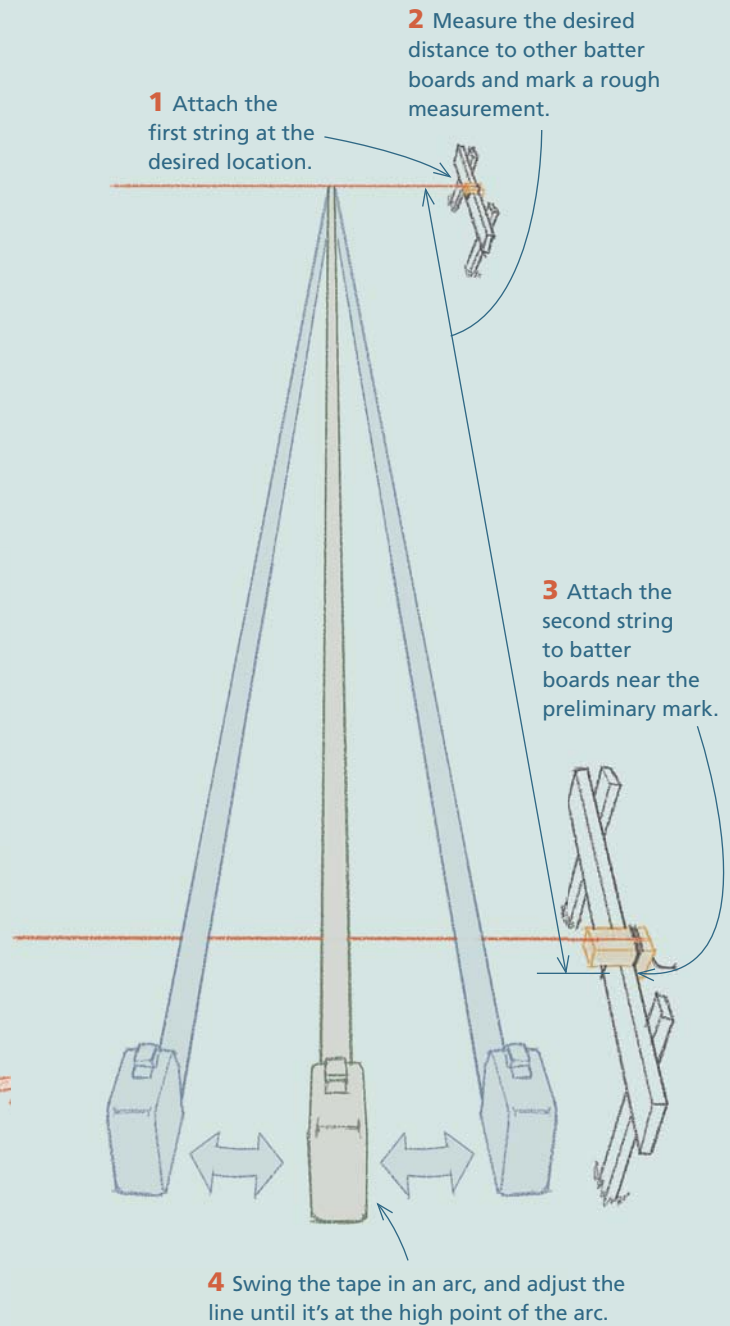

Laying Out a Crawlspace Foundation

In this example, the foundation is a 24-ft. by 40-ft. crawlspace that projects about 32 in. above the high point in the grade around the house. The foundation will be built from 8 x 8 x 16-in. concrete blocks. (These are often specified as CMUs, or concrete masonry units.)

The house is being built in an area where the frost line is 24 in. The excavator has scraped the ground clear of organic matter but left the grade roughly the same as the surrounding terrain. The opening is several feet larger than the footprint of the house. The location of the house has been roughly staked out by the owner and architect.

STEP 1 Find the high corner and establish the elevation of the foundation

1 Set up the leveling instrument and shoot the elevation of the four corners staked out by the owner. About 10 ft. beyond the high corner and along the line the long wall will follow, drive in two large stakes.

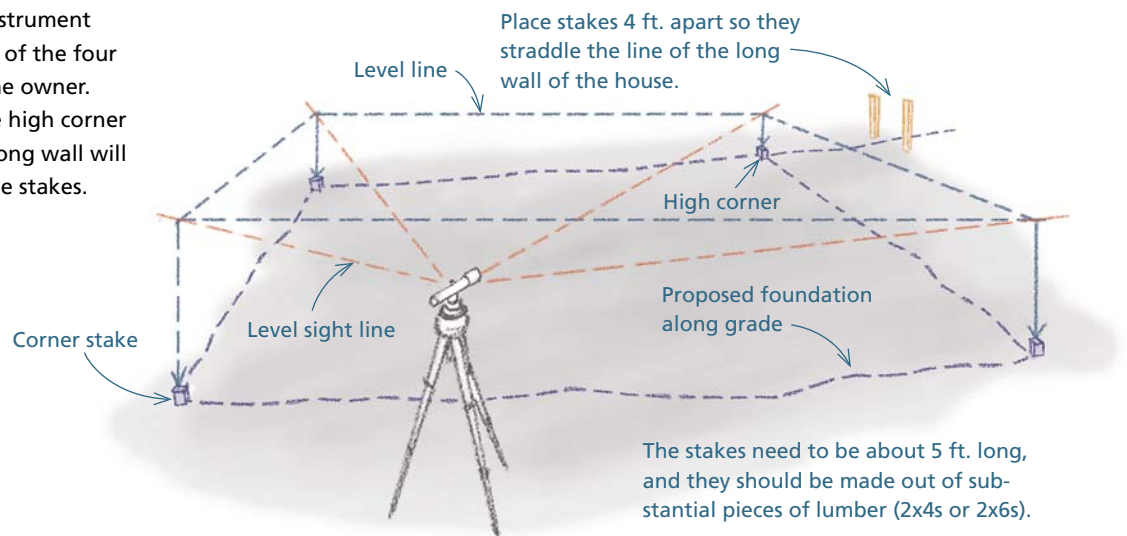

2 Check the difference in elevation between the level line projected by the instrument and the grade at the high corner. In this example, the level line shot by the instrument is 47 in. higher than the grade at the high corner. Since the planned top of foundation elevation is 32 in. above grade at this corner, the top of the foundation should be laid out 15 in. below the level line projected by the instrument ($47 - 32 = 15$). Repeat for the other corners.

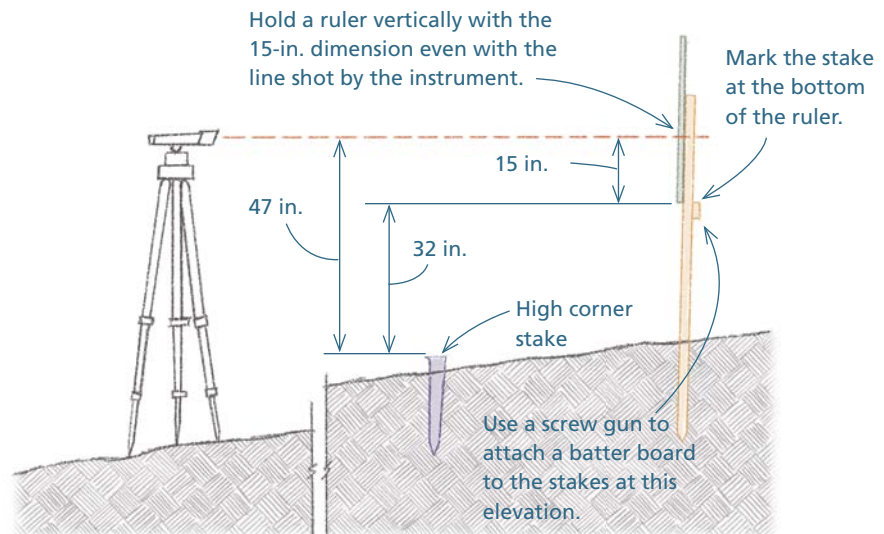

STEP 2 Create a level plane for the layout

Because the batter boards are at the same elevation, any lines extended from one batter board to another will be level and in the same plane. This level plane does two things. It establishes the elevation of the top of the foundation, and it ensures that measurements made along lines in that plane are accurate.

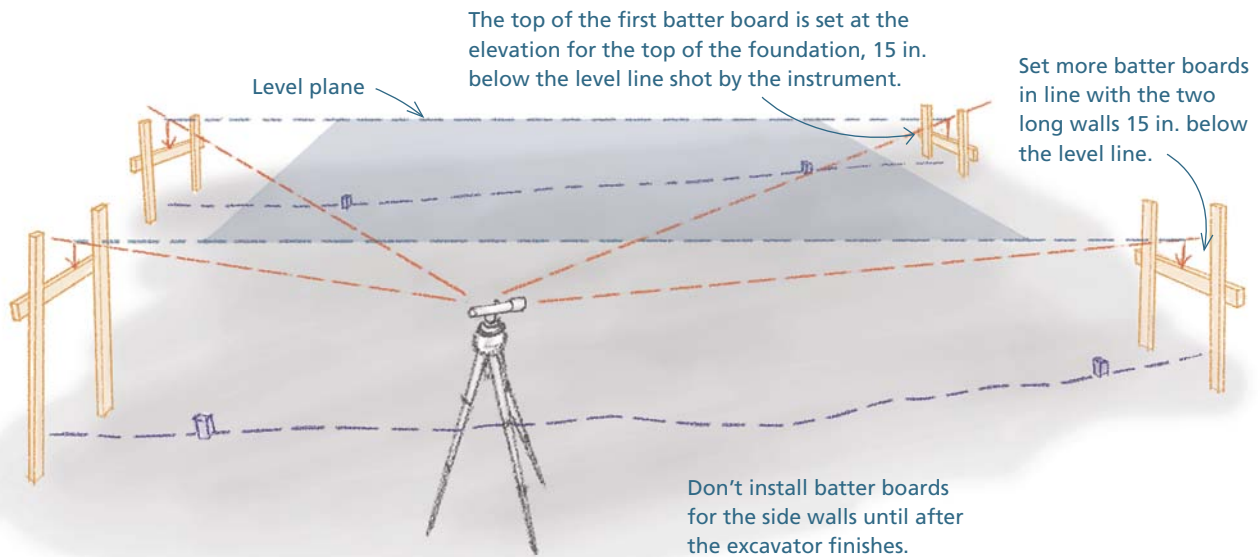

STEP 3 Lay out a 24-ft. by 40-ft. rectangle in the level plane

1 Set a string on the batter boards directly above the corner stakes. This string marks the outside edge of one of the walls.

3 Plumb up from the corner stake, and use a felt-tipped pen to mark the string.

2 Set a second string on the other pair of batter boards; carefully adjust this string until it's parallel to and exactly 24 ft. away from the first string. This string represents the outside edge of the other long wall.

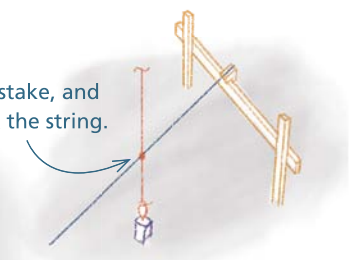
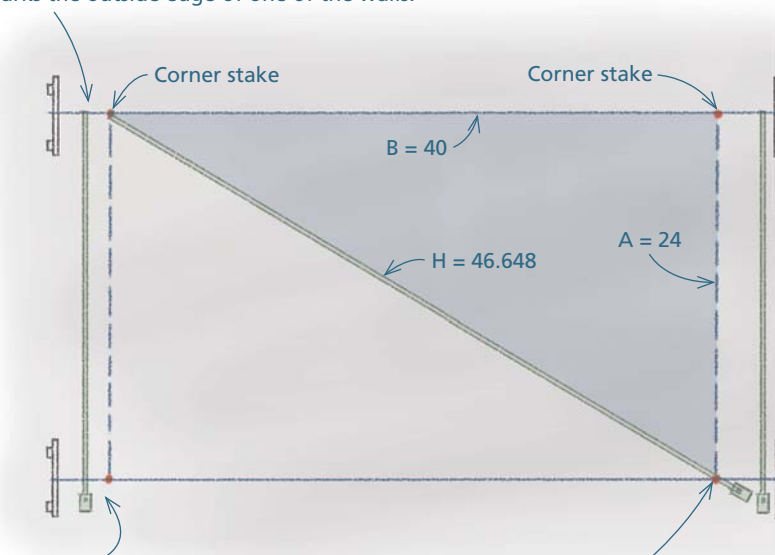

4 Use geometry to calculate the hypotenuse of a right triangle with an Altitude of 24 and a Base of 40. Plugging the numbers into the Pythagorean Theorem, the math is:

$$\begin{aligned} H &= \sqrt{24^2 + 40^2} \\ H &= \sqrt{576 + 1,600} \\ H &= \sqrt{2,176} \\ H &= 46.648 \end{aligned}$$

5 Use a tape laid out in the engineer's scale to pull 46.648 diagonally across from the two marks on the first string, and mark the third and fourth corners on the second string.

STEP 4 Record the layout on the batter boards

According to the plan, the foundation walls are 8 in. wide and the footings are 16 in. wide. The footings must be centered under the walls. Around the outside of the footing, you need an additional 6 in. or 8 in. for a drain system. To accommodate the footing and the drain system, a 24-in.-wide footing trench is planned.

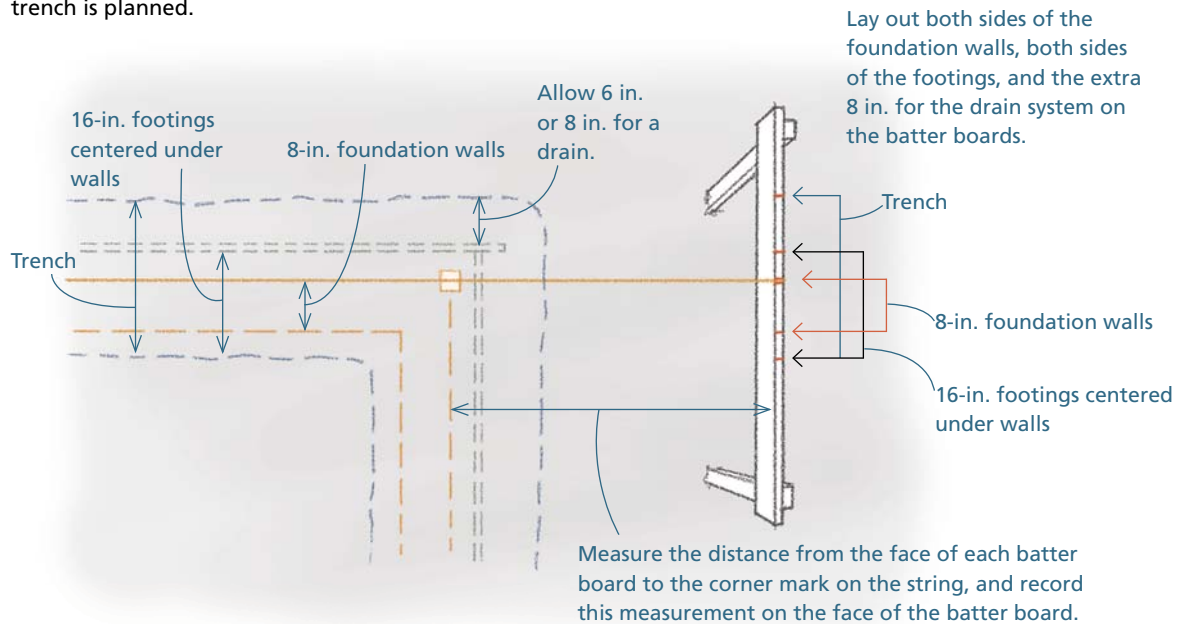

STEP 5 Mark the ground for the footing dig

1 To mark the trench for the long walls, set up lines on the two outside marks on the batter boards. Transfer these locations to the ground with a level, a plumb bob, or a laser.

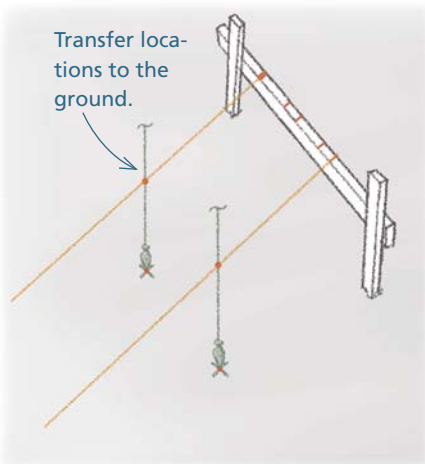

2 To mark the trench for the side walls, transfer the locations of the four corners from the string to the ground. Measure out 12 in. in both directions.

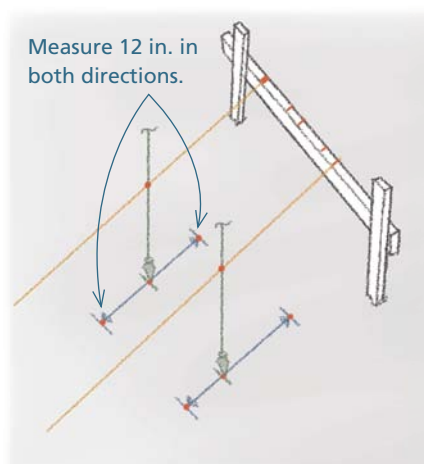

3 Set strings just above the ground at these locations, and mark the ground with lime, mortar, or spray paint.

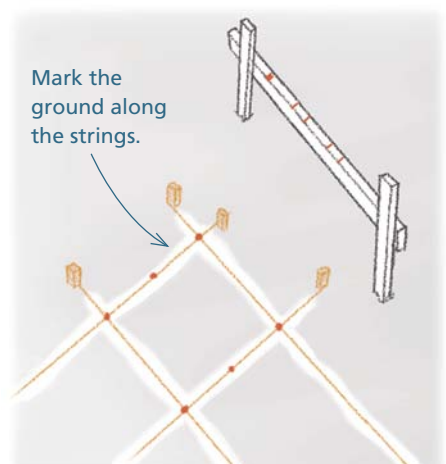

STEP 6 Dig the footing to the right depth

1 The bottom of the footing has to be at least 24 in. deep to get it below the frost line. Also, because the specified footing is 8 in. thick and the block courses will each be 8 in. high, the distance between the top of the foundation and the bottom of the footing has to be evenly divisible by 8 in.

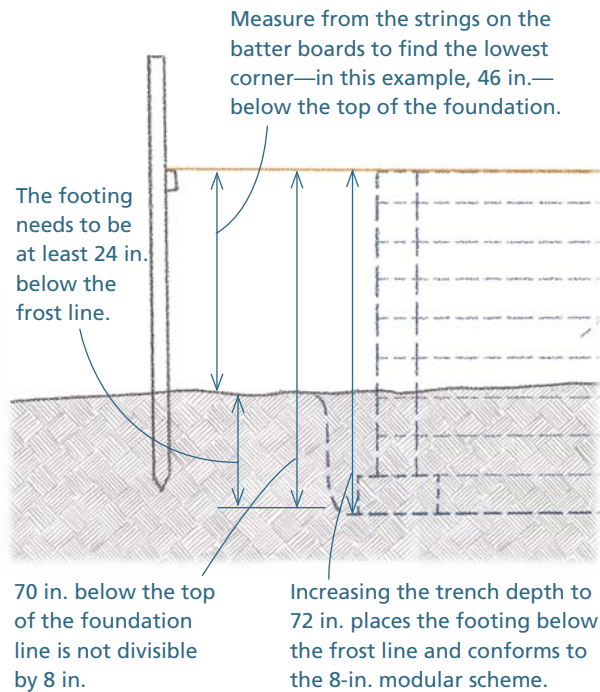

2 In this example, you have scheduled a backhoe to dig the footing the day after the layout, which means you've had to move the leveling instrument. For the excavation of the footing, you set it up again; this time it projects a level line that's $9\frac{3}{4}$ in. above the top of foundation.

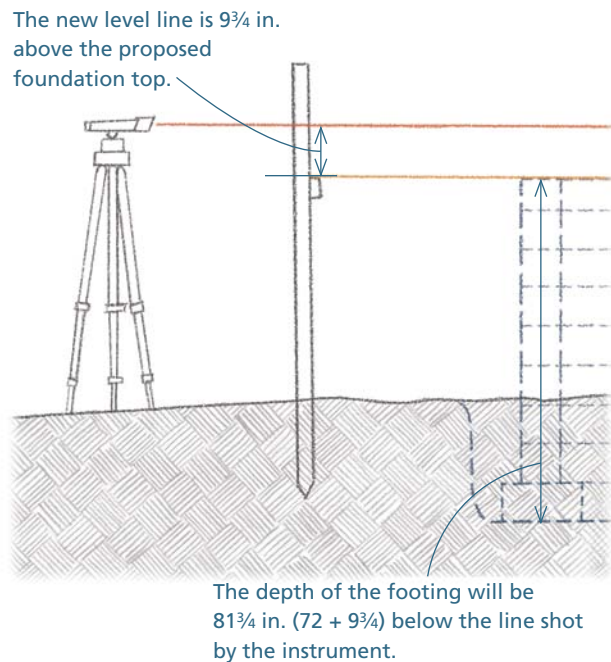

3 Remove the strings on the batter board to make room for the backhoe. To get the trench in the right place, the excavator digs to the lines you've made on the ground.

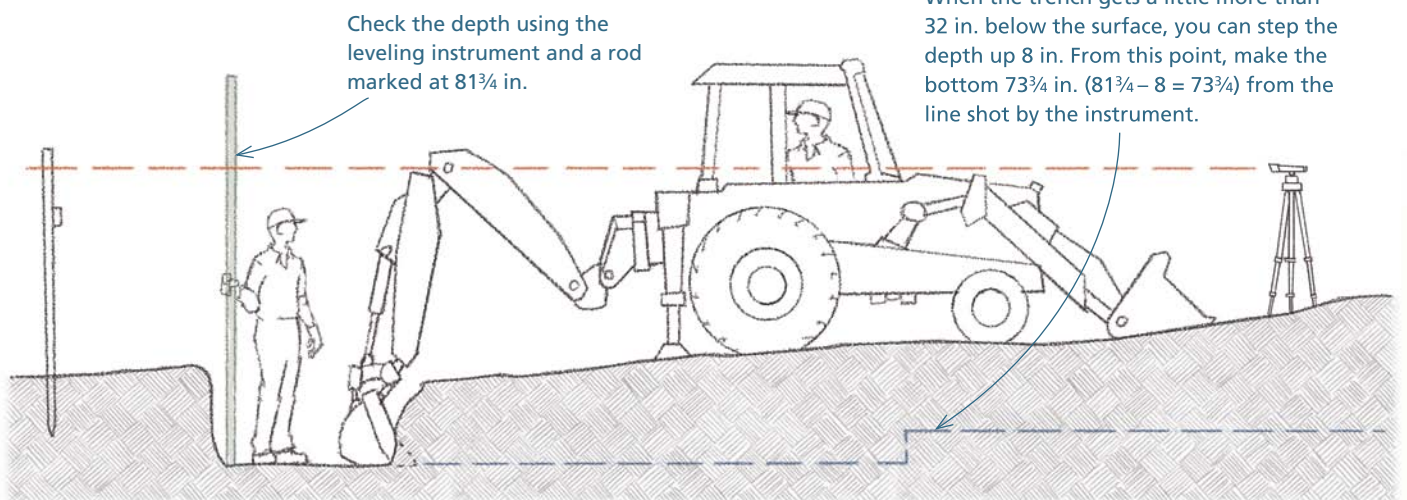

STEP 7 Finish the trench by hand

1 After the excavator finishes, install batter boards for the footing side walls. Attach new strings on the long wall batter boards. Measure the distance recorded on the face of the batter board to mark one of the corners.

Mark the foundation wall.

Mark both sides of the trench.

2 Measure 40 ft. down the string, and mark the second corner.

3 Pull the 46.648-ft. diagonals to lay out the third and fourth corners.

7 Lay out and dig footings for piers. They don't have to be below the frost line but should conform to the 8-in. modular scheme mentioned on p. 29.

6 Measure the elevation of the bottom of the footing against the strings. It should be 72 in. in the lower area and 64 in. in the upper area. Where the distance is less than these, dig to the target distances. Be careful not to dig too deep.

4 Pull strings through the corner marks to the side batter boards, and mark the batter boards where the strings cross them.

5 Set strings on the inside-of-trench and outside-of-trench marks on the batter boards. Level down from the strings to see how well the trench conforms to the layout. Use shovels to straighten out the sides of the trench and remove any loose dirt from the bottom.

STEP 8 Get ready for the pour

1 Set lines on the marks for the outside of the footing on the batter boards.

2 Transfer these locations to the bottom of the trench to get the forms in the right place.

3 Use 2x8s to form the outside of the footings.

4 As you install the forms, measure up to the lines to make sure you get the forms at the right elevation. The tops of the forms have to be at a height that conforms to the 8-in. modular scheme. The footings for the piers don't require forms.

Set the rebar for the footings as required by your local code and the specs on the plans.

STEP 9 Pour the footing

Before the concrete truck arrives, set up the leveling instrument and measure the difference in elevation between the top of the batter boards and the line shot by the instrument. Add the amount—in 8-in. increments—that you need to go down to get the tops of the pier footings at the right height.

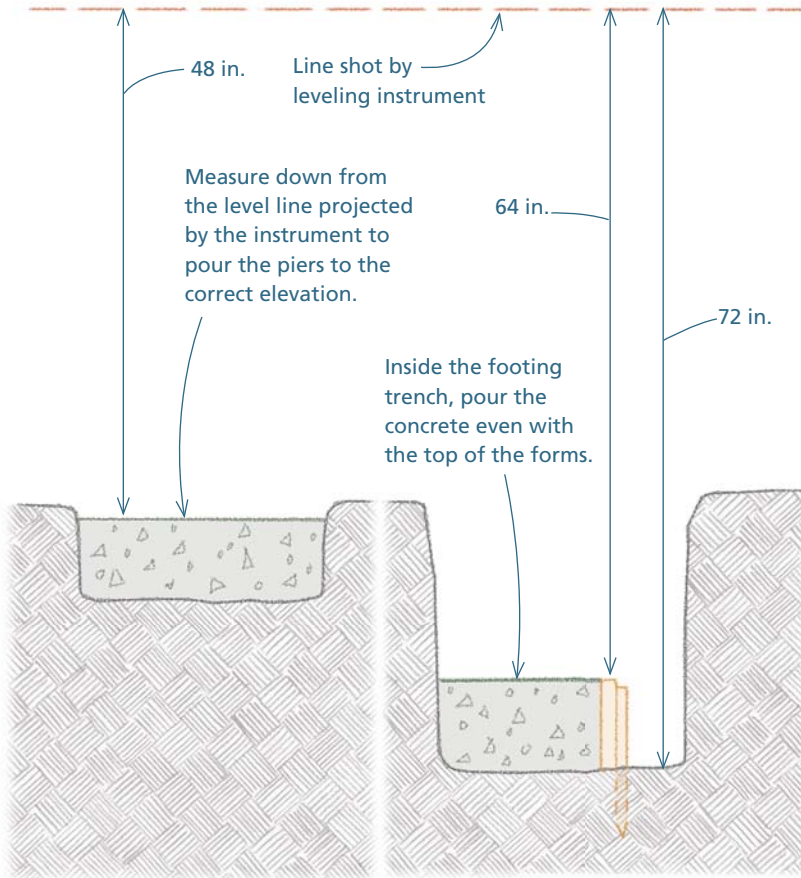

STEP 10 Lay out the walls

After the concrete hardens, set lines on the batter boards and use a level, plumb bob, or laser to transfer the locations of the walls to the top of the footing. Snap chalklines on the concrete to lay out the walls. Techniques for laying the blocks up to the line will be discussed in the final section of this chapter.

Before beginning the block work, make a quick checklist of the things to either allow for or include in the walls:

- Drainpipe to allow moisture inside the crawlspace to go through the wall and into the perimeter drain system
- Access door
- Opening for an HVAC duct
- Foundation vents
- Beam pockets
- Anchors to bolt the frame to the foundation

SAFETY FIRST

Cave-ins: A Deadly Hazard

The sides of trenches and basement excavations can collapse without warning. If a person is buried over his head in such a collapse, the chances of survival are less than one in ten. There are four things you can do to reduce the chance of a deadly cave-in:

- Any time you excavate an opening for a basement, make sure you dig at least 4 ft. beyond the footprint of the house; this keeps workers away from the deadly perimeter of the excavation.
- Slope the sides of the excavation away from the opening.
- Pile the spoils from a trench excavation at least 2 ft. back from the edge.
- Use a shoring system for deep trenches. For more on trenching safety, go to this OSHA site: <http://www.osha.gov/SLTC/trenchingexcavation/construction.html>

Building outside the Box

Although a rectangular floor plan has the advantages of speed and economy, designers and homeowners often desire more complicated shapes. The most common method of breaking out from the four walls of a rectangular house is to add more rectangles in the form of ells, wings, and insets. There are many occasions, however, when designers abandon the rectangle altogether and draw up buildings or parts of buildings with obtuse or acute angles or curved walls.

To lay out these different shapes, follow the same basic sequence that has just been described. First, lay out a level plane at either the top-of-foundation or the top-of-footing elevation. Then lay out the shape within that plane.

Adding rectangles to rectangles

To lay out these foundations, start by laying out the main rectangle and then add more batter boards or forms to lay out the additional rectangles. Use geometry to get the walls of the secondary rectangles square to the primary rectangle.

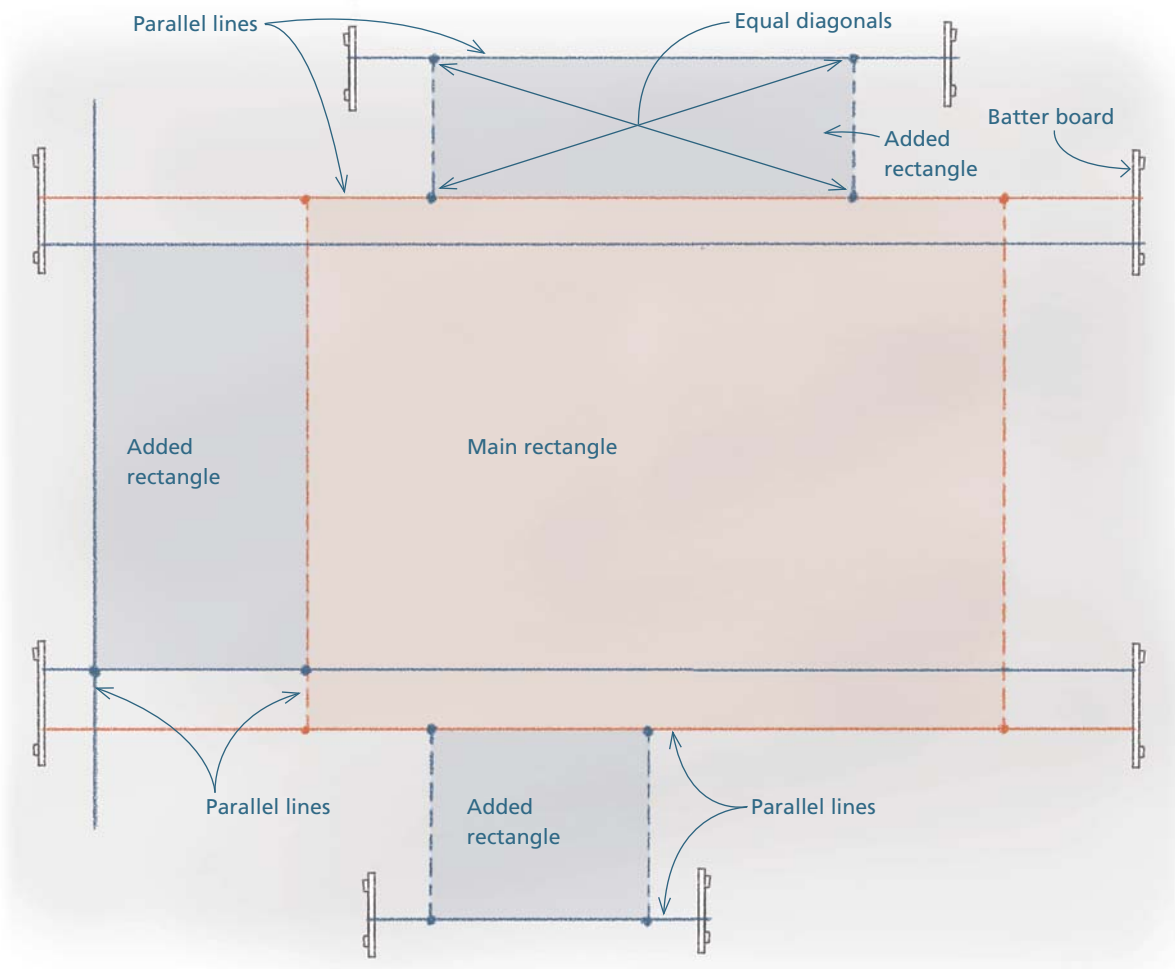

Moving away from the right angle

Once in a while, designers draw up buildings with walls that are not square to one another. To lay out these acute (less than 90°) or obtuse (more than 90°) angles, you can either use a precise surveying instrument or geometry. The designer should specify the point from which to pull the measurement as well as the exact dimensions of both the parallel line and the diagonal measurement. If the angle is simply specified in degrees, however, it's up to you to calculate the dimensions of a right triangle that corresponds to the degrees specified. To make these calculations, use the techniques described in "Working with Right Triangles" on p. 19.

• SURVEYING INSTRUMENT

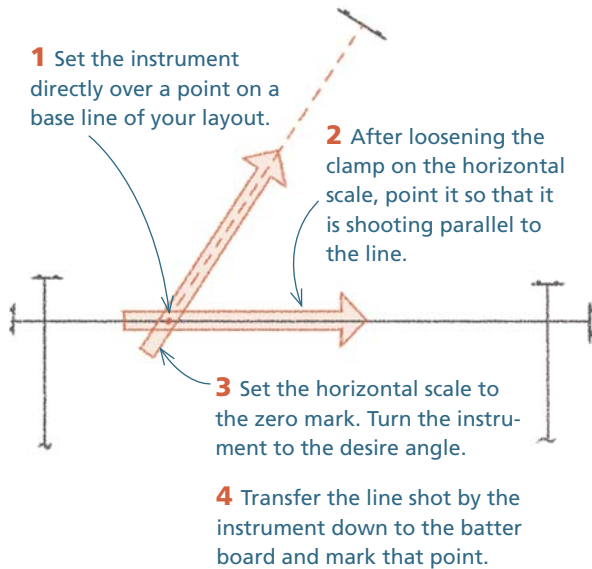

• GEOMETRY

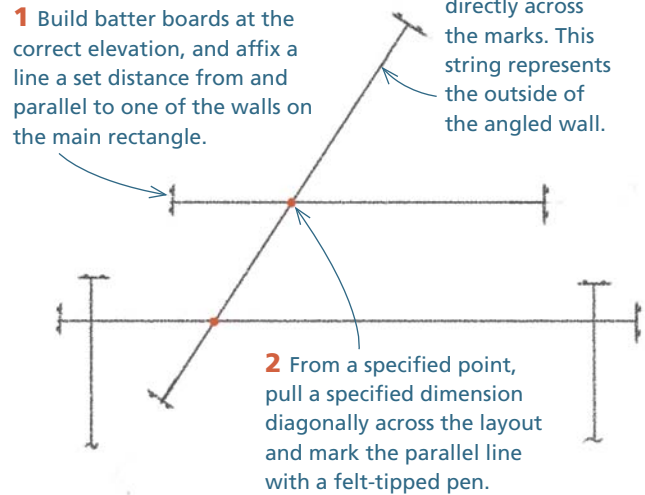

Laying out curved foundations

Curved foundations are usually drawn as circles or segments of circles. The first step in laying out a circular, semicircular, or arced foundation is to establish a pivot point. The location of this point should be specified in the plans. Lay out this point at the desired elevation, using a stake or a batter board. Once you've established the pivot point, create a beam compass to serve as the radii needed to lay out the parts of the foundation. On the beam compass, measure and mark the parts of the foundation out from the pivot point. These measurements include the distances from the pivot point to: the inside and outside of the footing trench; the inside and outside of the concrete footing; the inside and outside of the foundation wall; and the center of the foundation wall.

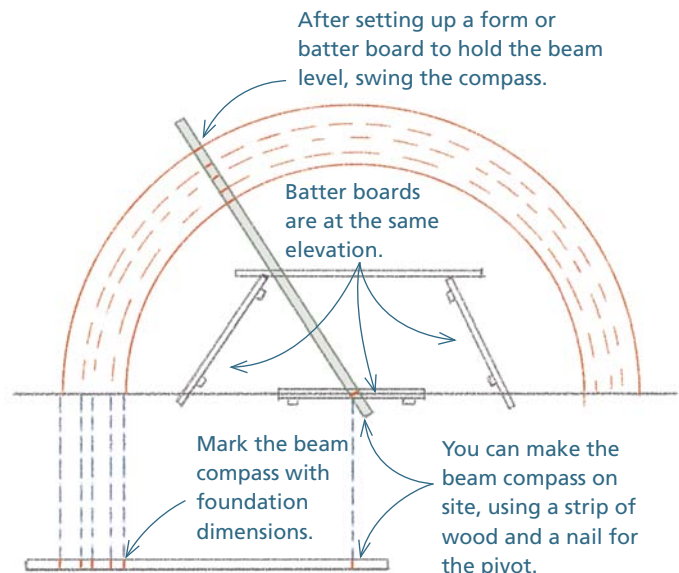

Building Foundation Walls

There are four different systems used for foundation walls. The two most common are masonry (mainly concrete blocks) and poured concrete. An emerging system uses insulating concrete forms, or ICFs (beyond the scope of this book). A fourth system, which is used to save money, is the permanent wood foundation, or PWF.

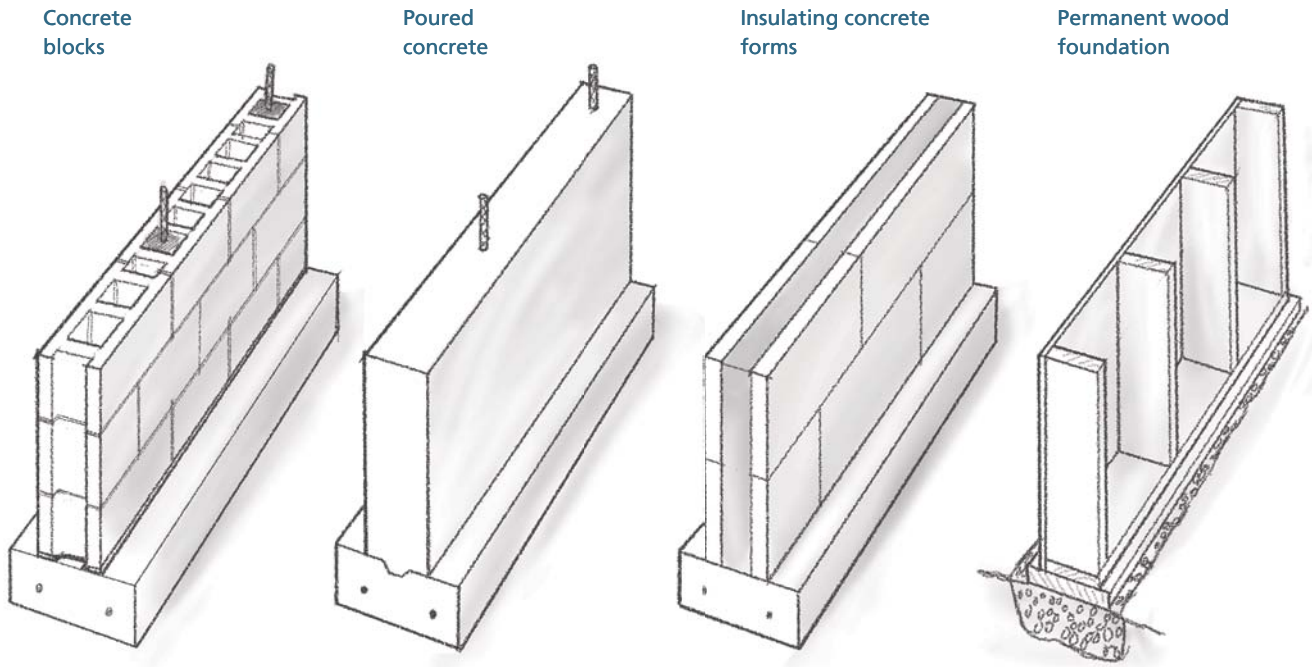

Concrete Block

Masonry consists of relatively small building units that are made from mineral substances (rock, clay, sand, portland cement, etc.) These units are usually assembled by hand into walls or other structures using cement-based mortar. There are many types of masonry units, including natural and man-made stone, structural clay tile, clay brick, concrete block, terra-cotta, and glass block.

The most common masonry units for foundations, however, are clay bricks and concrete blocks. These units can be combined into a composite wall, and in some parts of the United States brick-and-block foundations are very popular. In these walls, the bricks are on the outside and, although they are part of the structure, they are used mainly for aesthetic reasons.

Foundations built with concrete blocks only, however, are more common than brick-and-block. Because they are the most prevalent, this section will focus mainly on concrete block foundations.

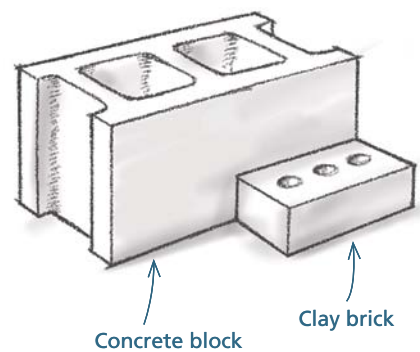

Strengths and weaknesses of masonry

Masonry alone typically has far more compressive strength than is necessary to support the weight of the house. Its main weakness is in its tensile strength. For this reason, unreinforced masonry foundations sometimes fail due to the lateral pressures imposed by the soil. To avoid this kind of failure, steel-reinforced foundations are often specified by designers or required by code.

Being comprised of mineral products, masonry fares well in direct contact with the soil. It's not an attractive habitat for insects and other pests and, more important, it's not a source of food for termites and rot-producing fungi.

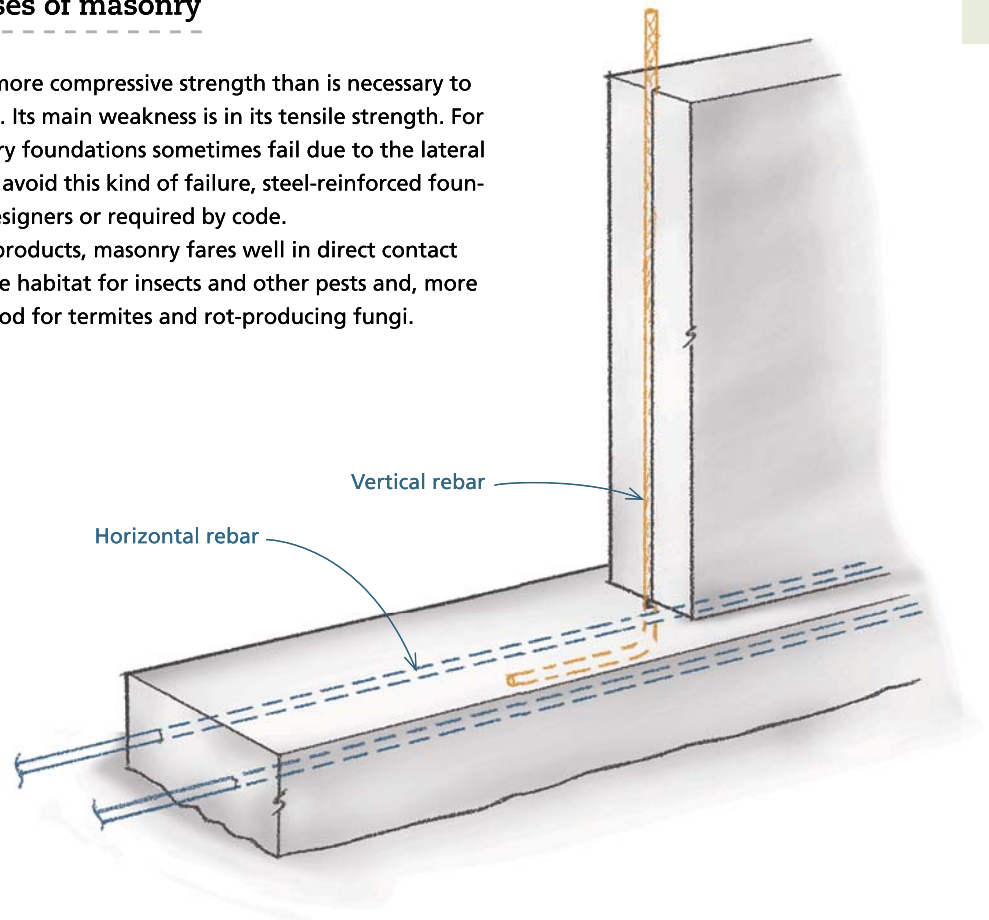

Modular layout

Modern bricks and blocks are designed to fit a layout scheme based on a 4-in. module. The units themselves are slightly less than the targeted module. This shortfall allows for the thickness of an ideal mortar joint, which is $\frac{3}{8}$ in. (The technical name for a concrete block is concrete masonry unit, which is often designated as a CMU.)

Three standard modular bricks plus three bed joints (horizontal joints), for example, are 8 in. high. One standard block plus one bed joint is 8 in. high. This dimensional compatibility makes it easy to combine brick and block in the same wall.

For block foundations, the layout usually starts at a top line and is measured down in 8-in. increments. (Once in a while, the plan calls for a 4-in. block at the top of the wall; in these cases, the layout has to include one 4-in. increment in addition to the 8-in. increments.)

On many freestanding structures, an inch or two variance in the final elevation of the top of the foundation is not a critical issue. On some jobs, such as additions to existing houses, the top of the foundation has to end precisely at a predetermined elevation. In these cases, the distance between the top of the footing and the top-of-foundation line is critical. Great care should be taken, therefore, to pour the footing at an elevation below the line that's evenly divisible by 4 in. or 8 in.

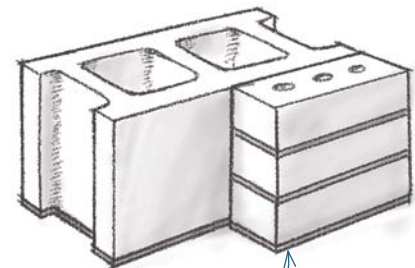

Three standard modular bricks plus three bed joints equal one standard block plus one bed joint. This equals 8 in. high.

Unit spacing along the length of the wall

The lengths of masonry units also fit into a 4-in. modular scheme. One brick with one head joint (vertical joint) is 8 in. long. One block with one head joint is 16 in. long. Similarly, the dimensions of the widths of these units also fit the modular scheme. A brick with a joint is 4 in. wide; a block with a joint is 8 in. wide. This ensures that the joints of each course are offset by half the length of the unit from the course below when you build corners.

When you build corners for any masonry wall, it's important to make sure you maintain the correct bonding pattern. After you build the first corner of a foundation, for example, you have to measure or set the units in place dry to determine which direction to place the first unit in the second corner.

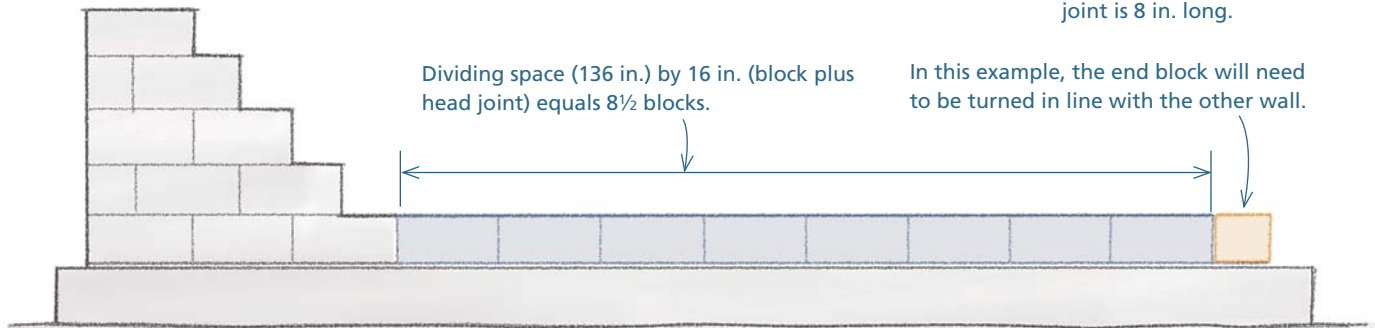
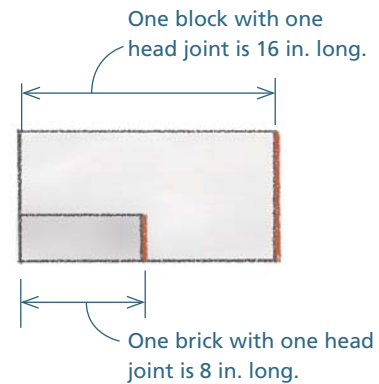

Fudging the layout

Although the 4-in. and 8-in. module is the rule in masonry, there is a little wiggle room. The courses can be expanded or contracted slightly by adjusting the thickness of the mortar joints. Most building codes, however, limit the amount that mortar joints can vary. The International Residential Code, for example, specifies that bed joints for a masonry foundation must be between $\frac{3}{8}$ in. and $\frac{1}{2}$ in. thick. The one exception to this rule is that the bed joint on the footing can be up to $\frac{3}{4}$ in. thick. This means that as much as $1\frac{3}{8}$ in. can be gained in a foundation that's nine block courses high ($\frac{1}{8}$ in. \times 8 = $1 + \frac{3}{8}$ in. = $1\frac{3}{8}$ in.).

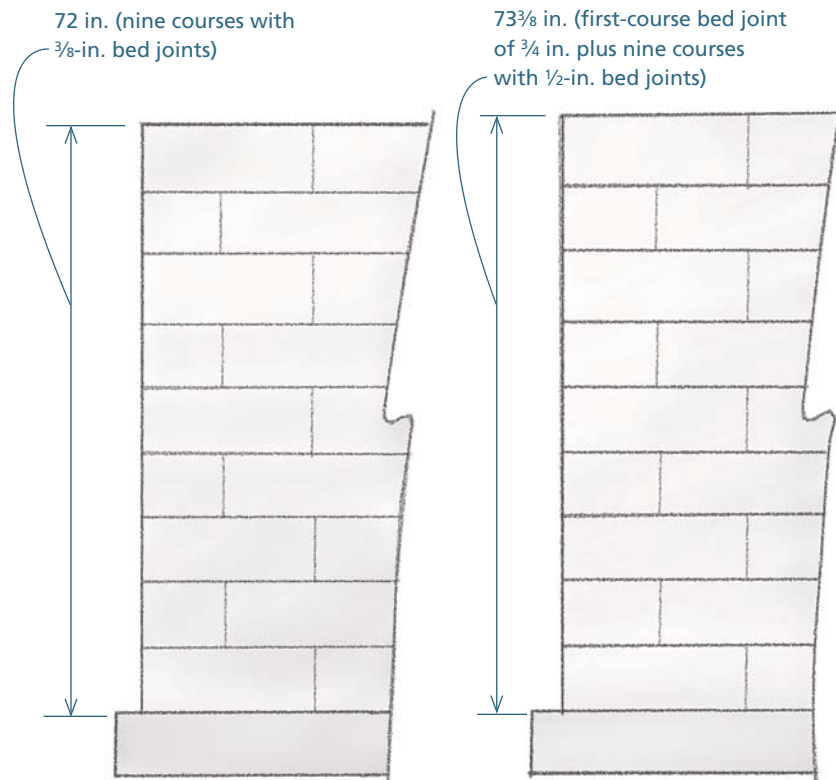

WAYS OF WORKING

Building Block Corners

Assuming that the distance between the top of the footing and the top-of-foundation line is correct, there are two basic ways to lay the units up to the top-of-foundation line: a level string line or a story pole. Story poles are available from tool manufacturers or can be fabricated on site using steel tubing or straight pieces of lumber.

● LEVEL STRING LINE METHOD

- 1 Transfer the line down to the top of the footing and lay up a corner lead.
- 2 Build the corner and measure the distance from the top of each course to the string.

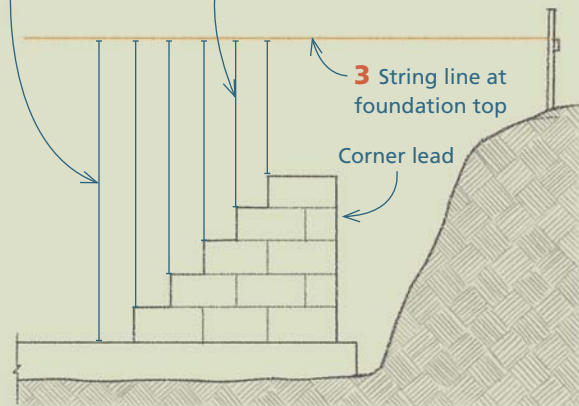

● STORY POLE IN CRAWLSPACE

- 1 Use a level to build the corner below grade.
- 2 Switch to story poles attached to the batter boards above grade.

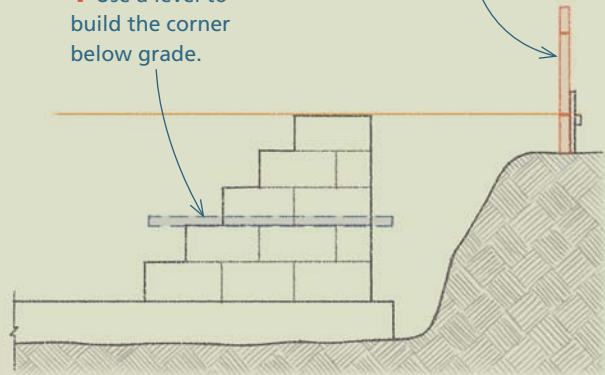

● STORY POLE METHOD 1

- 1 Attach a single pole precisely on the corner, and brace the top plumb in both directions.
- 2 Brace the top with C-clamps or screws.
- 3 Anchor the pole into the ground.
- 4 Attach the pole with a block of wood nailed to the footing form or with case-hardened nails driven into the concrete footing.

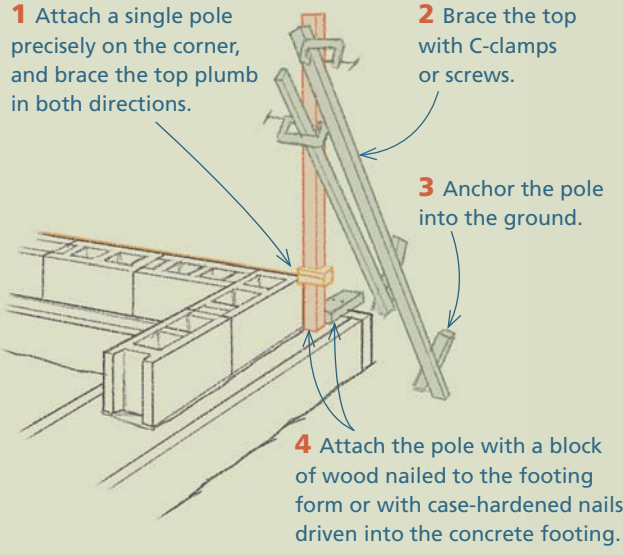

● STORY POLE METHOD 2

- 1 Attach and plumb two offset story poles for each corner.

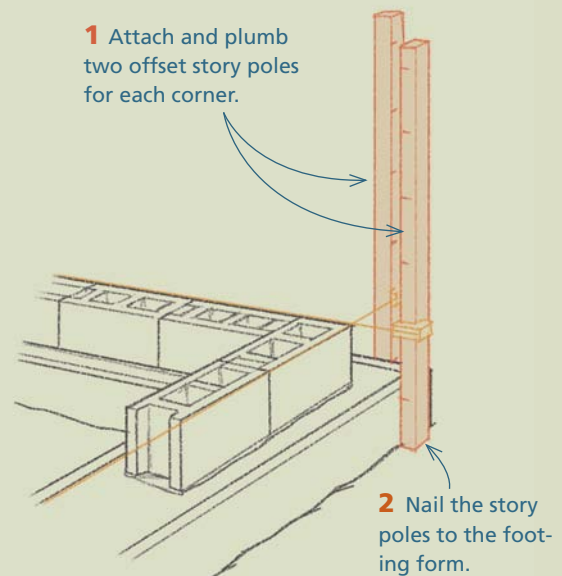

Laying blocks to a line

After laying up the corners or setting up story poles, attach a line from corner to corner to serve as a guide for laying blocks along the wall. Use line blocks to attach the string (see "Setting Up a Line Quickly and Accurately" on pp. 24–25). Make sure that the string has enough tension to keep it from sagging in the middle. Keep a tiny space, about the thickness of the string, between the block and the line. Doing this prevents the block from pushing the string out of line.

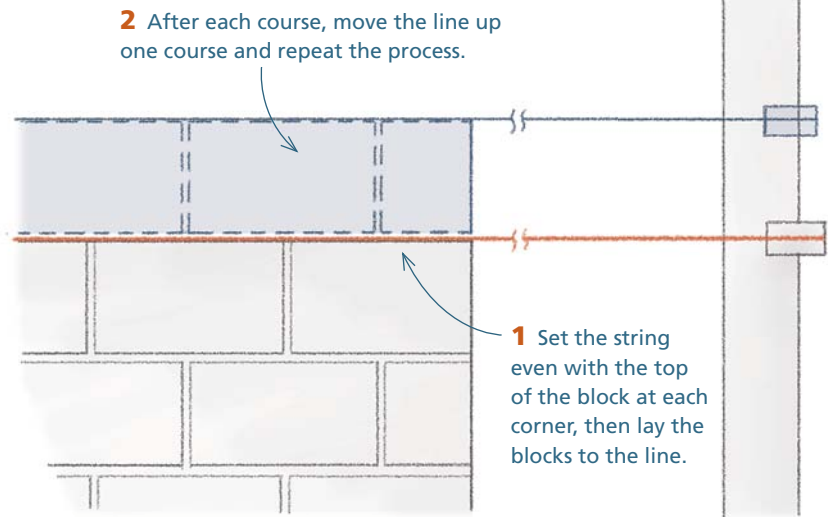

Mortar

Mortar is a generic term that describes any products used to bond masonry units together. The mortar required for foundations is typically Type S or Type M mortar. Mortar types are based on compressive strength, which is determined by the percentage of portland cement in the cementitious material in the mortar. Check with your local building official to see what type is required in your area. Although either of these types can be made by mixing portland cement and mason's lime, the most common way to achieve either type is by using masonry cement.

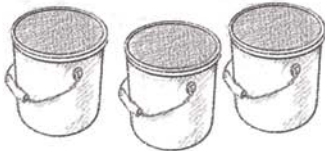

1 Mix 3 parts sand . . .



2 . . . and 1 part masonry cement.

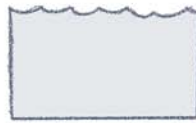

3 Add water gradually and continue mixing until the mortar is soft and mushy.



4 Good, workable mortar is wet but not soupy. It can be piled up with a trowel but yields readily when you place a block on it.

One way to proportion the dry ingredients of mortar is to use common, measured containers.

1 Fill three 5-gal. drywall buckets with sand.

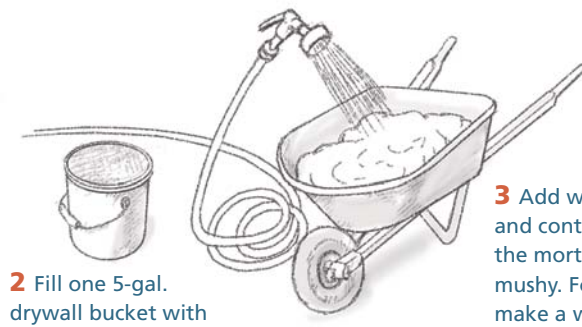

2 Fill one 5-gal. drywall bucket with masonry cement.

3 Add water gradually, and continue mixing until the mortar is soft and mushy. Four buckets will make a wheelbarrowful of mortar.

Troweling techniques

Wielding a trowel is a physical skill that can be acquired only through practice. Although there is no substitute for picking up a trowel and having at it, here are a few basic techniques to get you started.

• TROWELING THE FIRST COURSE

1 Pile mortar into a mound in a mortar pan.

2 Scoop a full but manageable trowelful.

3 With the fully loaded trowel a few inches above the footing, give the trowel a slight downward tilt. Without stopping, rotate your wrist and pull the trowel.

4 The motion is like the pull stroke when you're working with a handsaw.

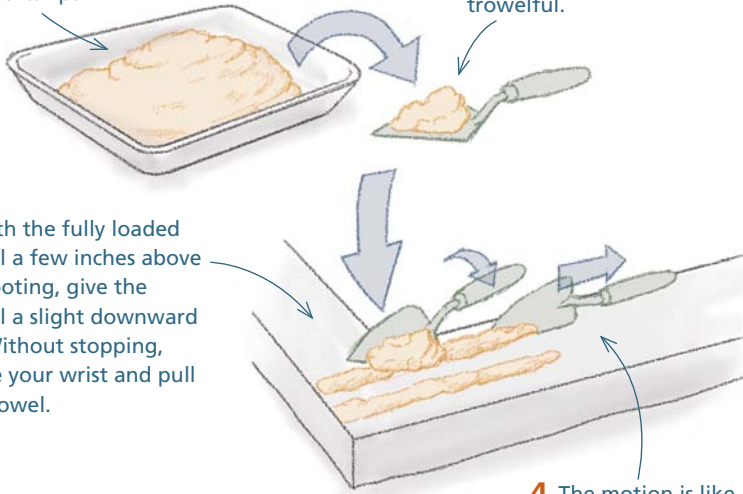

• TROWELING BLOCKS

To butter the end of a block (or brick), you have to turn the trowel over. The challenge is to keep the mortar from sliding off the overturned trowel.

1 Pick up half a trowelful.

2 With the mortar facing up, thrust the trowel straight down and stop it abruptly.

3 With the mortar flattened against the trowel, it stays put as you butter the ends of the block.

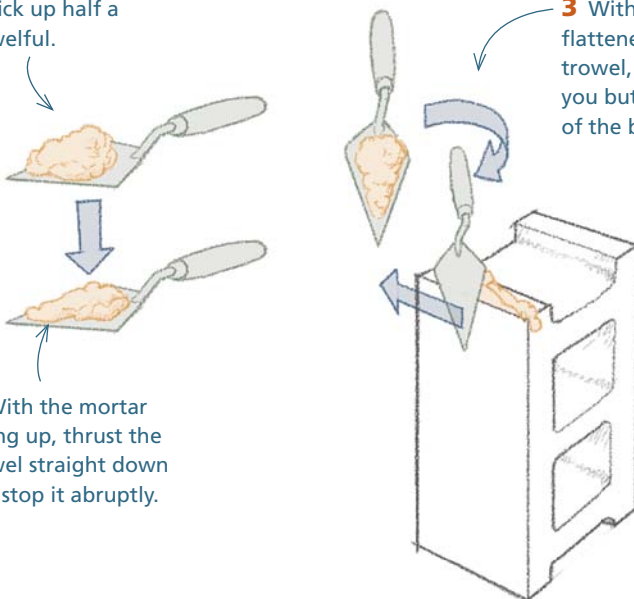

TOP TIP

Maximize the Bond

.....
In addition to having compressive strength, mortar has to bond the masonry units together tenaciously. To maximize bond, the units should be dry and the mortar should be as wet as possible and still have enough body to support the weight of the units. When mortar is spread on the surface of a dry, porous unit, the mortar is sucked into the pores, creating a mechanical as well as chemical bond.

There is an enduring myth that masons should soak units before laying them in a wall. In most cases, this is false. Most clay bricks and all concrete blocks should be kept dry before laying them in a wall. On rare occasions, unusually porous and dry clay bricks have an excessively high initial rate of absorption (IRA). These bricks suck the moisture out of the mortar at such a rate that the mortar dries almost immediately. This makes them difficult to work with and can have a negative effect on the bond. In these cases, the bricks should be wetted, then allowed to surface-dry before they're set in the wall. Wet masonry units should never be laid in a wall.
.....

Rebar set in footing

Block walls are often reinforced with steel and grout. The design should be drawn up by an engineer, or follow the specifications of the building code in your area. Rebar should be laid out so that it emerges from the footing in the center of the block cores. After the footing pour, builders sometimes bend incorrectly placed rebar to get it in line with the block core. This practice compromises the structural integrity of the system and should be avoided. It's far better to lay out the pieces of steel correctly prior to the footing pour.

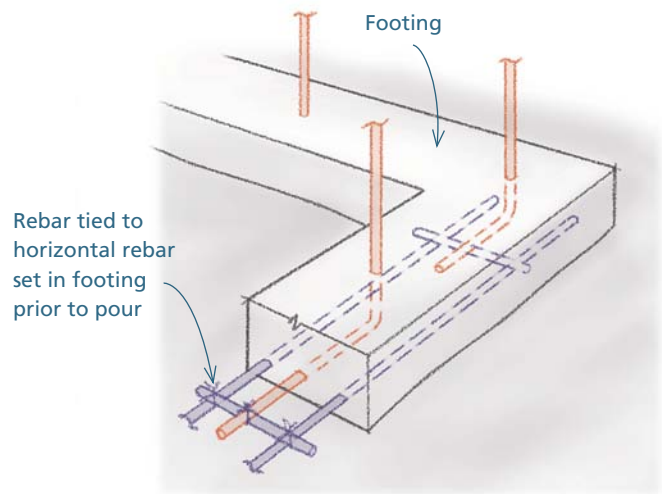

Create a cleanout

It is important to keep the footing around the vertical rebar clear of mortar droppings so the cavity can be completely filled with grout later. To ensure that the footing around the vertical rebar remains clean as you lay up the wall, you need to cut a "cleanout," a 4-in. by 4-in. opening in the first block that goes over the rebar. As the blocks are laid up, you can reach in and clean out the droppings around the rebar several times a day.

As the blocks are laid up, keep the rebar in the center of the core. Wire rebar positioners are available for this purpose.

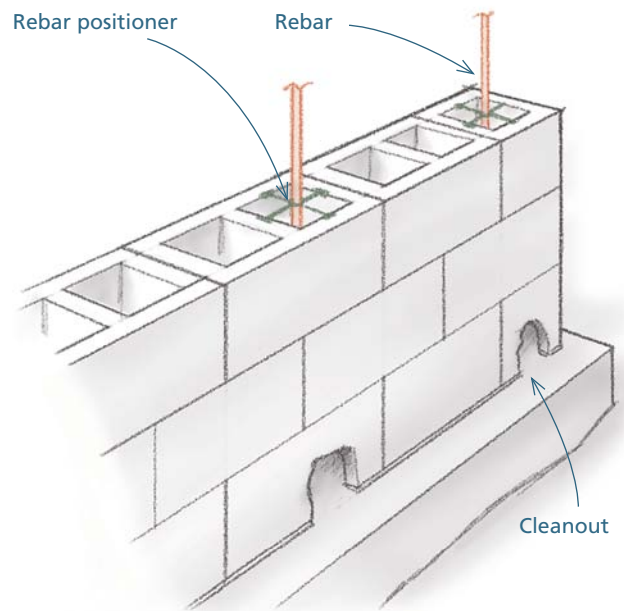

Grout block cavities

The grout must bond the masonry units and the rebar together. To achieve this bond, grout is much richer in portland cement than concrete and it has much more water. Because grout must fill the block cavities completely, pea gravel is often specified as the coarse aggregate. Structural engineers often specify the proportions for the grout on commercial masonry jobs. For residential projects, however, you can usually get an acceptable mix by conferring with your concrete supplier.

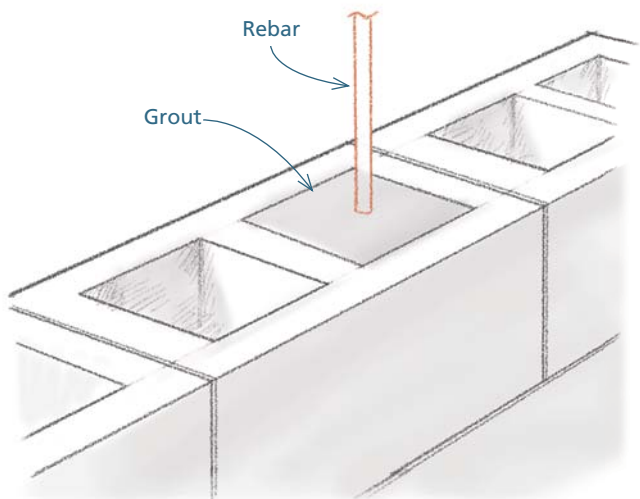

Poured Concrete

Concrete is made of four basic ingredients: water, portland cement, sand, and coarse aggregate (usually gravel or crushed stone). In a typical batch of wet concrete, only about 12% of the mix consists of portland cement. Most of the material is aggregate; sand comprises about 28% of the mix, while gravel or crushed stone makes up 44% of the total volume. The final ingredient, water, varies considerably from batch to batch. Ideally, the water content should be about 15% of the volume. On many jobs, air is also mixed into the concrete, typically accounting for about 6% of the volume.

When water is mixed with the dry ingredients, a chemical reaction in the portland cement, called hydration, takes place. Hydration causes the most important constituents of the cement, the calcium silicates, to dissolve and then gradually reform as calcium silicate hydrate and calcium hydroxide. As hydration proceeds, these newly formed compounds harden and bond to each other and to the grains of sand and stones that they surround. Meanwhile, if air-entraining chemicals are mixed in, billions of microscopic air pockets per cubic yard are formed. After air-entrained concrete is fully cured, it stands up to freezing temperatures much better than untreated concrete. The tiny chambers relieve internal pressure on the concrete by providing space for the water to expand into when it freezes.

SAFETY FIRST

Before the Truck Comes

.....
The trucks used to deliver concrete and blocks are often tall enough to hit overhead power lines. When they do, they can electrocute anyone who touches any metal part of the truck. Always reconnoiter the route the truck will follow and, if a line poses a hazard, come up with an alternate route or have the line disconnected by the power company.
.....

Strengths and weaknesses of concrete

Because the tools and skills required for installing concrete and unit masonry are so different, they are considered separate branches of the building industry. The materials, however, are often indistinguishable. The ingredients of grout, for example, are the same as those in concrete. Concrete blocks are made from concrete. A stone wall often consists of the same materials as are found in concrete: stone, sand, and portland cement. And, while brick is made of a different material (clay), both brick and concrete are mineral substances with great compressive strength.

Unreinforced concrete is relatively weak in tensile strength.

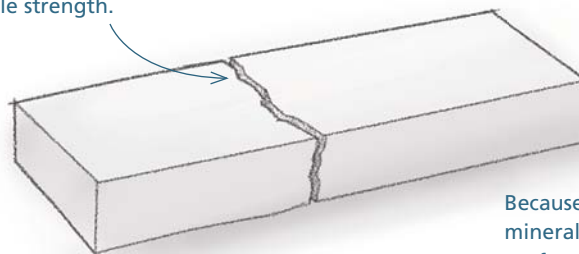

Because it is made from mineral products, concrete performs well in contact with the ground.

Concrete is often reinforced with steel.

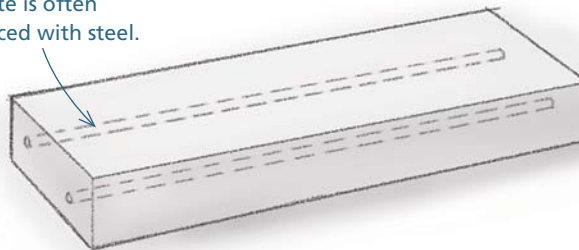

Slump Test

To measure the consistency of wet concrete, engineers have developed the slump test. Although residential builders rarely do slump tests, they use a given "slump" to indicate how much water they want mixed in when they order concrete. Concrete with a 4-in. slump is typical for residential work.

1 Fill a cone-shaped container of specified proportions with concrete.

2 Flip the container. Slowly lift the cone off the concrete.

3 Measure how much the cone of concrete sags.

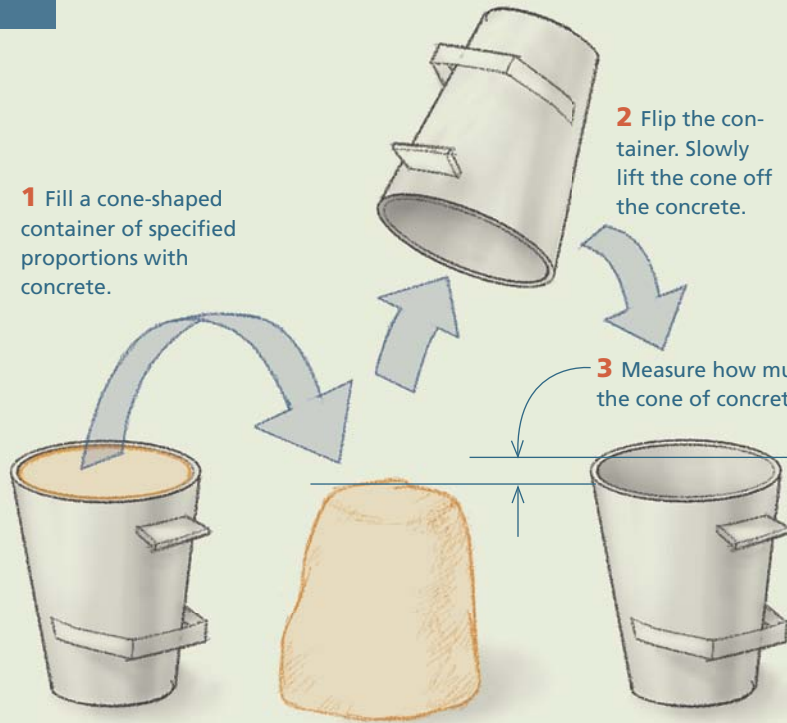

Water and concrete

Ready-mixed concrete is proportioned at the concrete plant and delivered by truck ready to place. The amount of water added to the mix at the plant is specified by the buyer in terms of "slump" (see "Slump Test" above). The lower the slump, the less water added and the stiffer the mix. Concrete with a 2-in. slump, for example, is so stiff that it has to be pulled down the chute of the truck and physically pulled into place and packed into forms to avoid honeycombs (voids). Concrete with a 5-in. slump, on the other hand, flows down the chute, spreads out, and fills forms easily.

Slump has a direct impact on the workability of the concrete. Low-slump concrete is a lot harder to place and finish than high-slump concrete. There is a tendency, therefore, on the part of the workers in the field to want to add water to the concrete. Ready-mix trucks carry water for this purpose.

Ready-mix concrete suppliers, however, carefully document the amount that is added, both at the plant and during the pour. The reason they do this is because the amount of water mixed into concrete has a direct impact on the strength and durability of the finished product.

The amount of water needed to cause hydration is surprisingly small. All the dry ingredients have to be thoroughly dampened but they don't need



to be saturated with water. Every drop of water that is not consumed by the hydration process has to exit the concrete via evaporation.

It is this evaporating water that causes problems. Above the amount necessary for hydration, each added gallon of water per cubic yard decreases the compressive strength of the concrete 200 to 300 psi (pounds per square inch) and increases shrinkage potential about 10%. Furthermore, as the water-to-cement ratio climbs, the durability of the concrete declines; problems such as cracks, spalling, and freeze/thaw deterioration are directly related to the water content in concrete.

Since excessive water can have a negative effect on the long-term performance of the concrete, builders and/or owners should not leave the issue of water content entirely in the hands of those who place the concrete. Because adding water makes their job easier, leaving the issue of slump in the hands of the concrete crew is a little like asking the fox to guard the hen house. The slump of the concrete should be discussed and agreed upon prior to the pour and, after the truck arrives, strict limits should be placed on how much water can be added. If you're not present at the pour, you can determine how much water was added by reviewing the documentation of the ready-mix supplier.

Curing concrete

During hydration, cement and water are consumed as a new product—the hardened concrete—is born. Although concrete is usually hard enough to walk on within a few hours, it continues to hydrate long after it initially sets and it does not achieve full strength for months or even years. The most important period for hydration, however, is the first week after the concrete is poured. It is during this critical period that hydration proceeds most rapidly. Because concrete attains about half of its ultimate strength in this first crucial week, water within the concrete must not be allowed to evaporate completely or to freeze.

Because water must be present for hydration to occur, you should take measures to keep the water within the concrete for several days. This process, called curing, should not be confused with the initial mixing of water into concrete. As noted above, hydration does not require very much water, and you should use water sparingly when making concrete. Once the concrete is mixed and poured, however, you need to keep that water within the concrete

Keep forms in place for several days and seal the top.

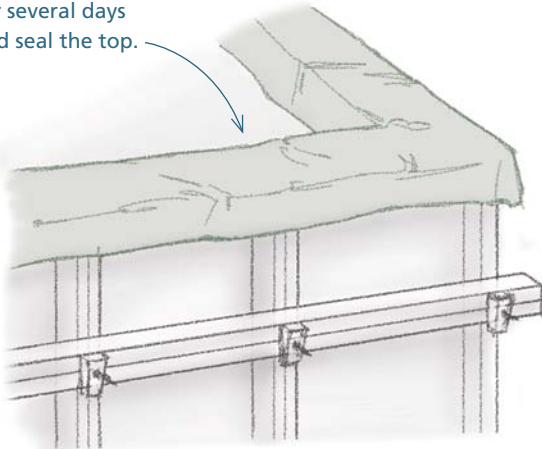

Cover the concrete with damp burlap. Make sure the burlap stays damp for several days.

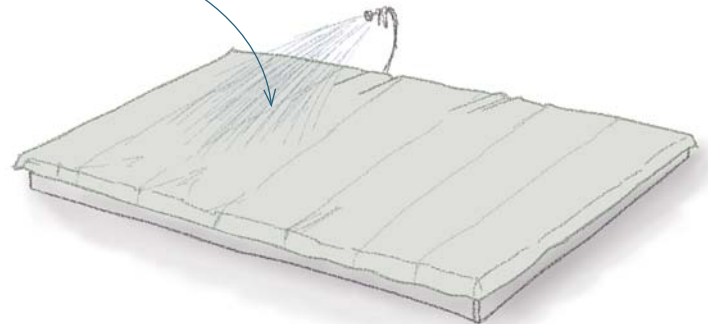

for as long as possible. In other words, the strongest concrete is made with as little water as possible, retained inside the concrete for as long as possible.

There are two basic ways to cure concrete. The first is to seal the water inside the concrete. On flat work, such as a basement floor, you can cover the floor with plastic sheets or spray on a special waterproof coating called curing compound. Do this several hours after the concrete has been finished and achieved its initial set. Make sure you seal up the edges of the plastic sheets; one way to do this is to place sand on top of the plastic around the perimeter of the slab. On vertical work, such as foundation walls, the moisture can be retained by keeping the forms in place for several days and just sealing the top, exposed edge (see the drawing at left on p. 43).

The second basic strategy for curing concrete is to keep the exposed surface of the concrete damp. One way to do this is to cover the concrete with damp burlap. Make sure the burlap stays damp for several days.

Forming concrete

Wet concrete weighs more than 4,000 lb. per cubic yard. When first mixed, it's an amorphous blob that slumps and spreads out when poured. (Although the amount of slump varies with the percentage of water in the mix, it almost always has some slump.) When you pour this material into a form, the form has to contain the slump of the wet concrete. The concrete presses down and out, exerting tremendous pressure on the inside walls of the forms. This pressure can force forms to bulge out or fail catastrophically, like a burst dam.

When you build forms for footings or foundation walls, you have to build them strong enough to contain this pressure. This pressure grows substantially with the height of the form and the quantity of concrete poured. Flatwork (sidewalks, floors, driveways, etc.), for example, sometimes requires several

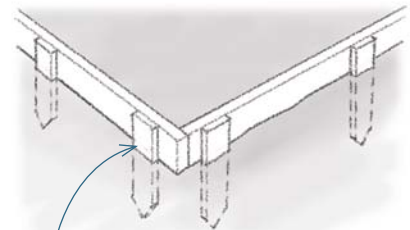

2x4s or 2x6s are nailed to small stakes driven into the ground every 4 ft.

For footings 8 in. to 12 in. tall and slab-on-grade foundations, use 1½-in.-thick lumber for the forms.

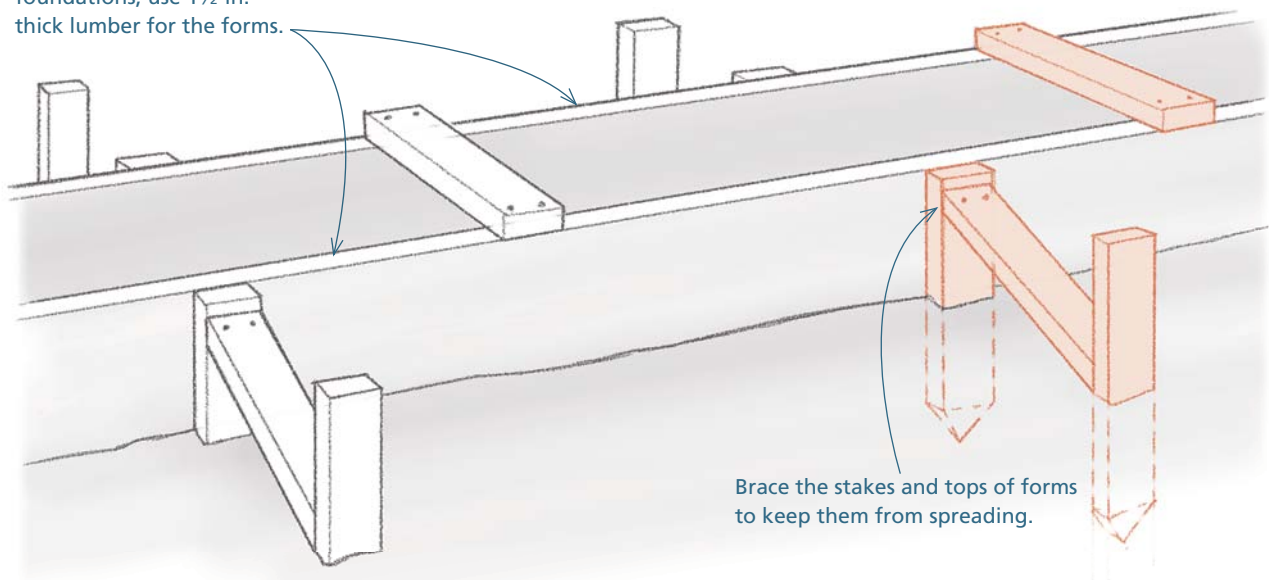

Brace the stakes and tops of forms to keep them from spreading.

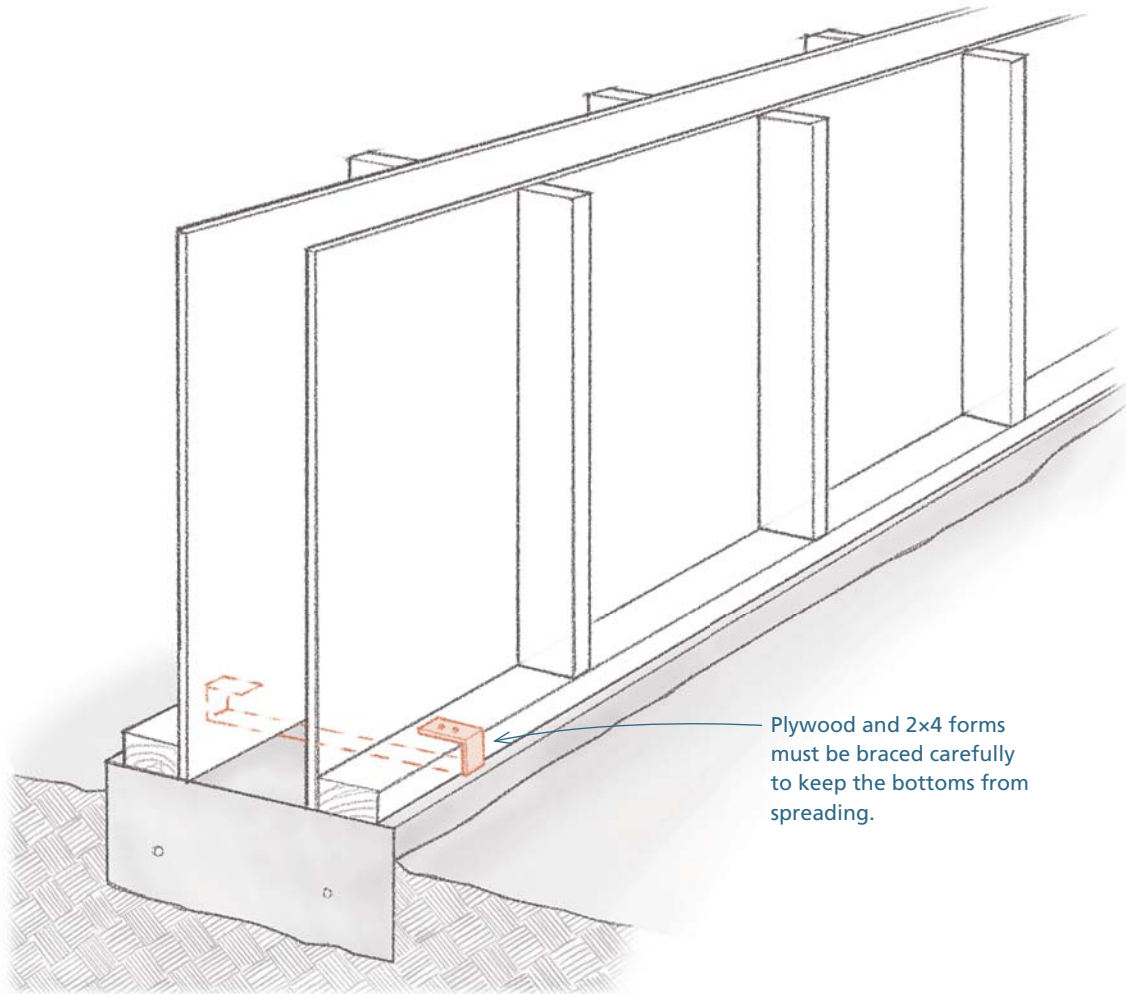

yards of concrete. But, because the forms are usually just 4 in. to 6 in. high, the thrusting forces of the concrete in these pours are relatively small. Typically, the forms for these structures are made out of 2x4s or 2x6s nailed to small stakes driven into the ground every 4 ft. or so.

When the forms are 8 in. to 12 in. tall, as is the case for some footings and slab-on-grade foundations, 1½-in.-thick lumber can still be used. However, the stakes have to be braced and the tops of the forms have to be connected to keep them from spreading.

Forms for walls 16 in. to 24 in. high typically require 4-in.-thick panels built like the exterior walls of a house. These forms, built out of 2x4s and plywood, must be braced carefully. To keep the bottoms from spreading, carpenters often lay steel strapping on the footing, then wrap it up the outside of the forms and nail it securely.

Forms for foundation walls taller than 24 in. can be erected with prefabricated panels, or they can be built on site with plywood and studs. Because of the tremendous pressure of the concrete, steel ties must be used to keep the walls from spreading, buckling, or blowing out altogether. If you need to form walls higher than 24 in., consider using a foundation subcontractor. He'll have the forms, the hardware, and the experience to build a form that can contain the pressure of the concrete.

TOP TIP

Cubic Inches in a Cubic Yard

.....
 The number 46,656 is not easy to remember and there's no reason to do so. A yard is 36 in. and a cubic yard is $36 \times 36 \times 36$, which is 46,656. Anytime you need this number for estimating volume, just do the multiplication and write it down.

Aligning and bracing the forms

When forming foundation walls, the layout often takes place at the footing level. After snapping chalklines on the top of the footing, set the bottoms of the forms on the lines, then brace them plumb. To ensure that the walls end up straight, brace the corner panels plumb first, then set up a string stretching from corner to corner. Brace the intermediate panels to the string. Anchor the bottom of the braces to stakes driven into the ground, and attach the tops of the braces to the panels with screws or nails.

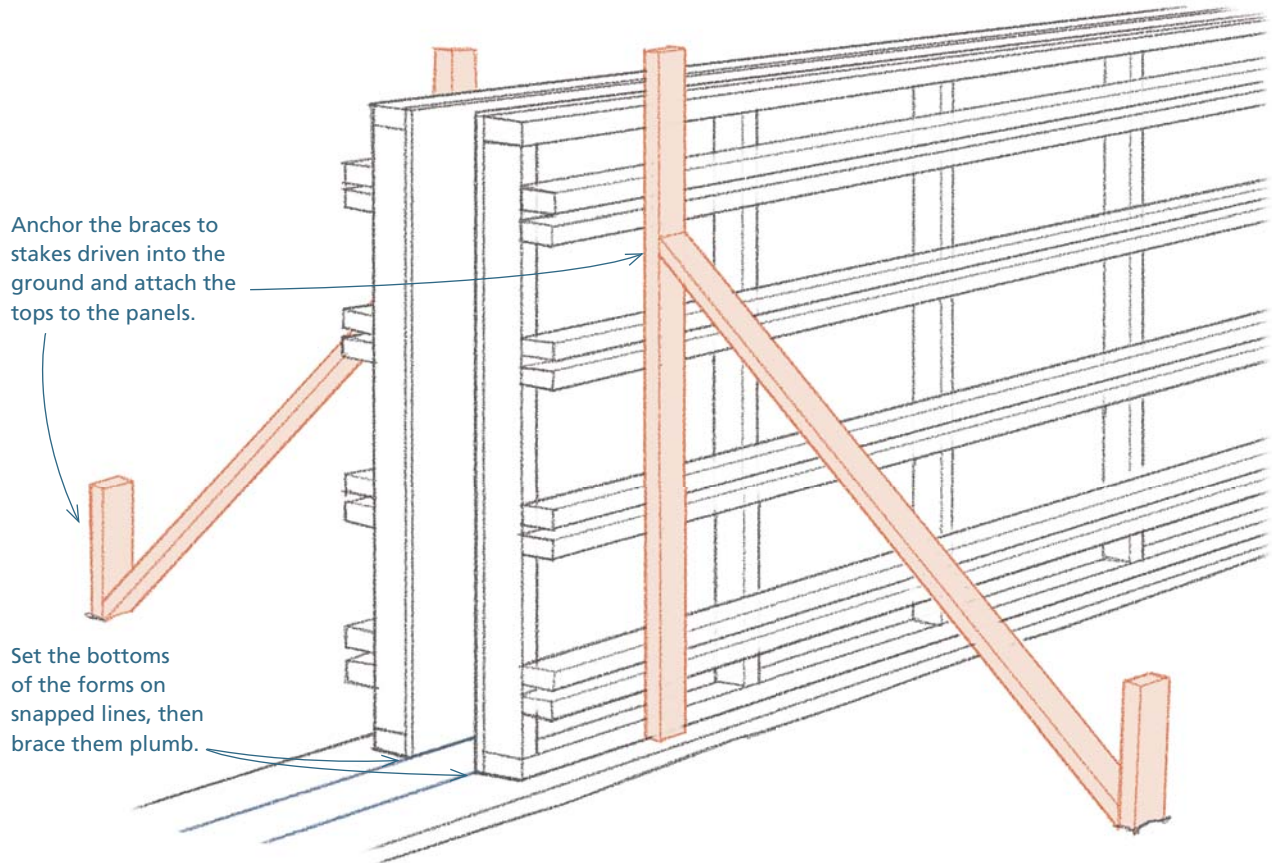

Estimating concrete

In the United States, ready-mix concrete is sold by the cubic yard. To estimate the amount needed for a pour, carefully measure the length, width, and depth of the area enclosed by the forms. After converting these measurements to a single measuring unit—usually feet or inches—multiply the length \times the width \times the depth to arrive at the volume in cubic feet or cubic inches. If you have the volume in cubic feet, divide by 27 (the number of cubic feet in a cubic yard) to convert to cubic yards. If you have the volume in cubic inches, divide by 46,656 (the number of cubic inches in a cubic yard) to convert to cubic yards. To make sure you don't end up just short of concrete at the end of the pour, add about 10% for footings and 5% for walls. These conversions can be simplified by using a construction calculator.

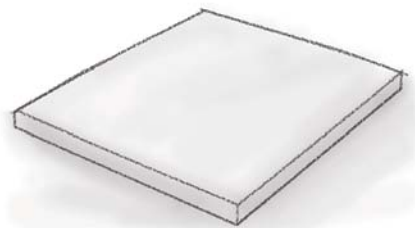

Admixtures

Concrete suppliers often offer chemical admixtures that can improve the workability or enhance the performance of concrete. The most common of these are air-entrainment admixtures. Other admixtures include chemicals that inhibit corrosion, reduce alkali-silica reaction, add bonding and damp-proofing properties, and provide coloring. Retarding admixtures are used in hot weather to slow down the setting rate of concrete. Accelerating admixtures are used in cold weather to increase the rate at which concrete gains strength. This means that the concrete has to be protected from freezing temperatures for a shorter period.

Plasticizing admixtures make low-to-normal slump concrete more fluid without adding more water. This makes the concrete easier to place but doesn't weaken it. This has given rise to a new use of the word "slump." You can now order concrete with a "4-in. slump, plasticized to a 6-in. slump." The 4-in. slump is the slump created by the water content and the additional 2 in. of slump is created by the admixture.

Plasticizing admixtures work great for vertical pours, but they can cause problems for flat pours. This is because the effects of the plasticizing chemicals are temporary, lasting 30 to 60 minutes. When they wear off, the surface of the concrete can harden rather suddenly, making finishing difficult.

WAYS OF WORKING

When to Hire a Concrete Subcontractor

Because of the stakes involved, builders often use concrete subcontractors. For large flat pours, such as a basement floor, experienced concrete masons can quickly pull the concrete flat, cut it level with a straightedge (often called a screed), and float the surface. Speed is of the essence, especially in hot weather. Concrete crews that specialize in flat work not only get the concrete placed and floated quickly but also have the skills and equipment to achieve very smooth finished surfaces.

Large vertical pours, such as basement walls, require an enor-

mous amount of concrete. Crews that specialize in basement walls have reusable manufactured forms that are engineered to contain the concrete. They have the experience to see how to bring in a truck close to the forms or to realize when they're going to need to rent a concrete pump. They've also developed the physical skills and the brawn needed to handle a chute or a hose full of concrete.

Large concrete pours are often best left to specialists. Waiting for a subcontractor, however, presents its own set of problems. After you dig, form, and install steel in a

footing, for example, you shouldn't delay the pour. If it rains and the footing gets flooded, you'll have to spend a lot more time getting the footing dry and removing silt that has washed into the trench.

If you're a custom builder or a remodeling contractor, it pays to be able to do small to medium pours "in house." The key is to know what your crew can handle. This is something that you can determine only gradually, through experience. Starting with small pours, you can gradually develop the skills, acquire the tools, and gain the confidence needed for larger pours.

Permanent Wood Foundations (PWFs)

Permanent wood foundations, or PWFs, have been used in the United States since the 1960s. While these foundations require careful detailing, they can be built by any carpentry crew using standard framing techniques.

The footings for these foundations are typically 8 in. of compacted gravel in a 16-in.-wide trench. A treated plate (usually a 2×10 or 2×12) is laid flat on this bed of gravel. Then a 2×6 or 2×8 framed wall, sheathed with treated plywood, is nailed to the plate.

PWFs are engineered systems and the details vary according to the type of foundation you're building, the soil you encounter, and the design load of the house. Before starting a PWF, make sure you know and understand the design, and check with your local building official to see what's required in your area.

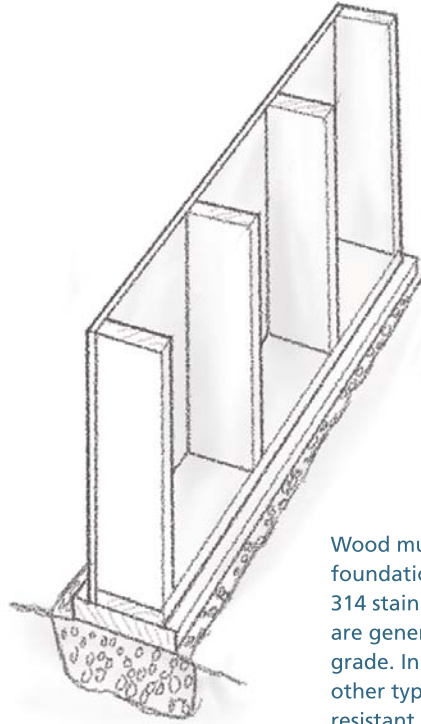

Wood must be rated for foundations. Types 304 or 316 stainless-steel fasteners are generally required below grade. In some jurisdictions, other types of corrosion-resistant nail are permitted above grade.

Controlling water

Controlling water is an essential part of these systems. First, you have to drain water from the footings, the base of the wall, and under the floor. Second, you must add a protective barrier to the outside of the foundation.

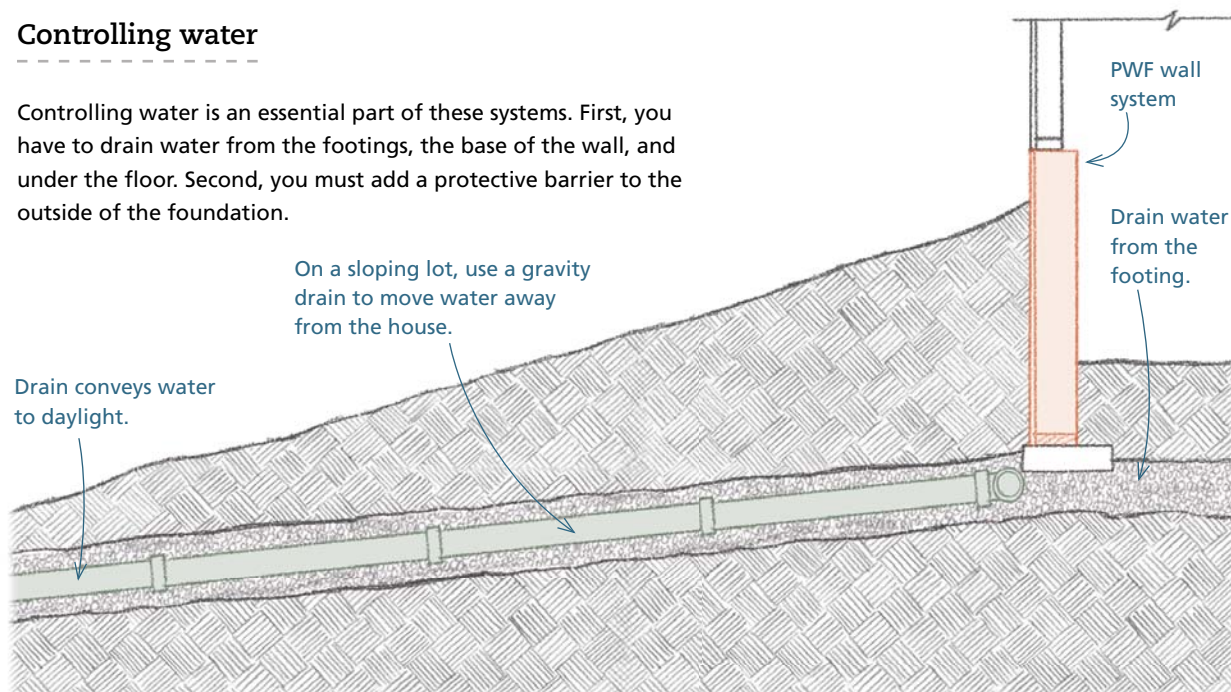

Basements

In basements, a concrete slab is poured inside the walls. This slab restrains the inward thrust that the soil exerts against the bottom of the walls. A treated wood floor, also built inside the walls, can be used in lieu of the concrete.

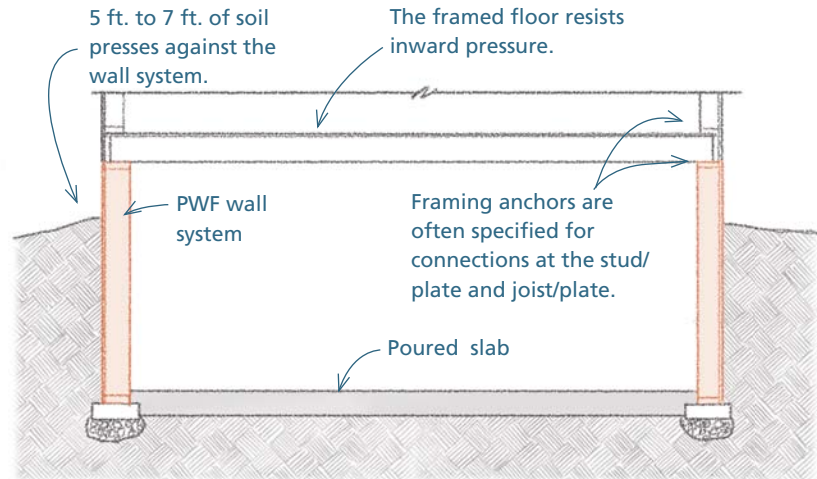

Crawlspace foundations

In crawlspace foundations, there is less imbalanced fill between the inside and outside of the foundation wall. In these situations, the soil inside the wall is used to counteract pressure from the soil along the outside.

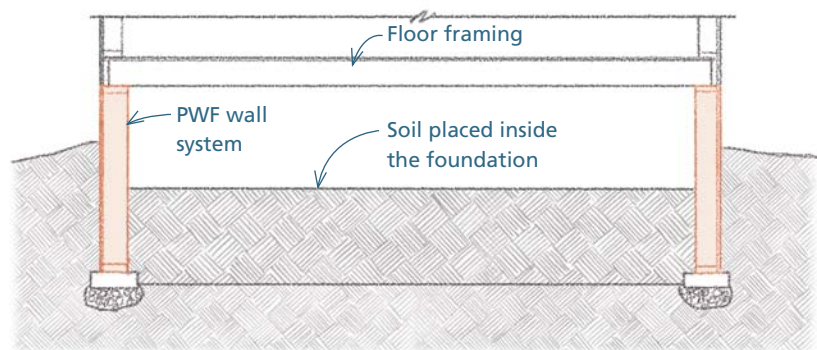

Protective barrier

The second part of the process is a protective barrier on the outside of the foundation. Because of the importance of keeping these systems dry, PWFs are not a good choice in very wet locations or where there's a high water table.

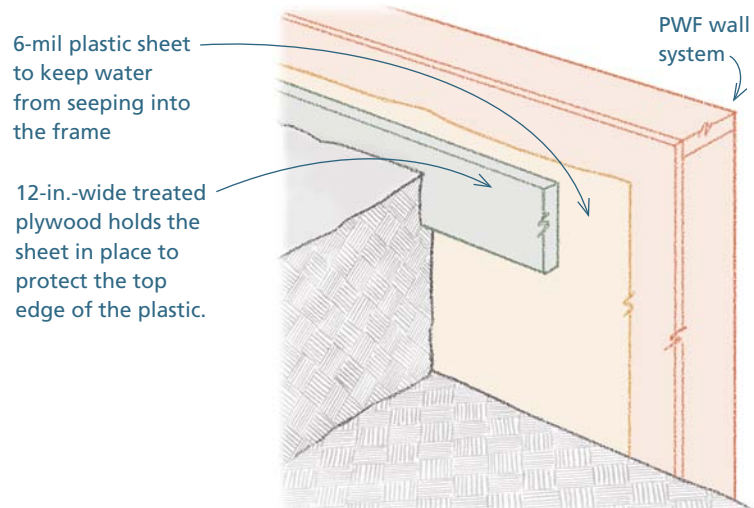

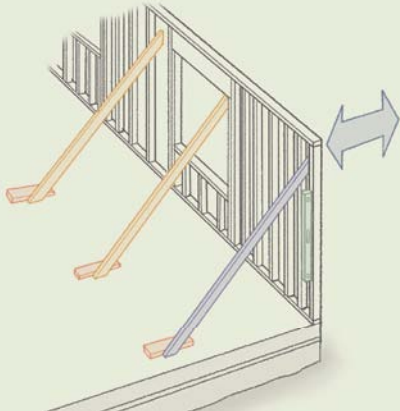
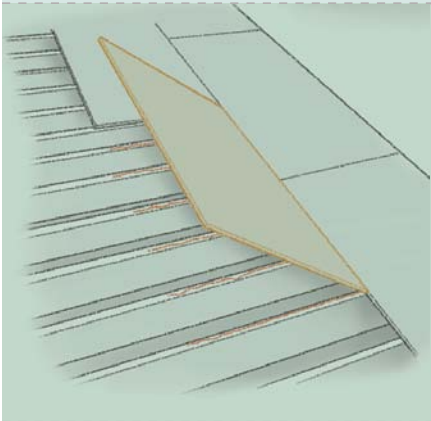
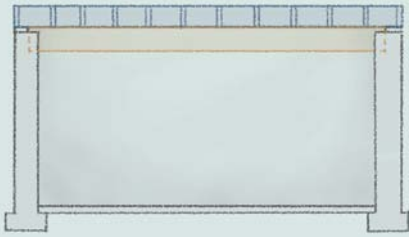
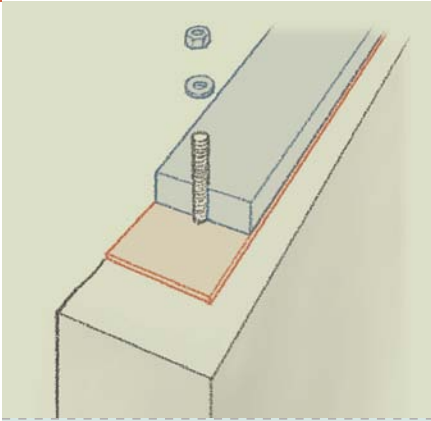

Framing Floors, Walls, and Ceilings

AFTER COMPLETING THE FOUNDATION, builders should have a level surface 8 in. or more above grade. Upon this surface, they begin the frame of the house, a structure that will define the shape of the house and the layout of the rooms. Due to the size and complexity of house frames, this book devotes three chapters to their construction. This chapter concentrates on floors, walls, and ceilings. Chapters 3 and 4 will be devoted to framing roofs.

The Three Functions of the Frame

When you build the frame of a house, you need to do three things. First and foremost, you have to build a safe and sound structure. Second, you have to build a structure that accommodates almost all the subsequent work on the house. As you build the frame, then, you must look far into the future and provide for the needs of plumbers, drywall hangers, siders, finish carpenters, and other specialty trade contractors. Third, you should build a structure that meets acceptable standards of quality.

Building a Safe and Sound Structure

The primary responsibility of frame carpenters is to build a safe and durable structure. This aspect of frame carpentry is usually regulated by local building officials.

Loads

The frame supports both the weight of the building (dead loads) and the loads added by the inhabitants and the environment (live loads). The dead loads imposed on the walls of a house include the combined weight of floors, ceilings, and roof structures that bear on them and the weight of all the materials that cover those structures. The live loads include furniture, equipment, people, wind, snow, and seismic forces.

Both dead and live loads vary from building to building. If a customer wants to roof her house in slate, for example, the dead load from the roof covering would be substantially more than if she opts to use asphalt shingles.

The most important live loads are those generated by natural forces. Because those forces differ according to the climate and topography of the land, code requirements for frames vary from region to region. Different codes, in fact, often govern different areas within the same state. It's essential to know and understand the code where you build.



A house is subject to dead loads and live loads.

Built-in durability

The frame not only has to have the strength to carry and resist loads, but it also has to endure in an often hostile environment. The two biggest threats to wood-framed houses are water and fire.

Although the first defenses against rainwater intrusion are the materials that are later installed on the exterior of the frame, the frame itself contains built-in features that help the building resist these destructive forces. One basic built-in feature is the shape of the roof. A pitched roof helps move rainwater down and off the house. Eaves and rakes provide even more built-in protection because they keep most of the runoff from the roof away from the outside of the walls.

Another built-in feature that resists the destructive force of water is the use of treated wood wherever the wood is attached to masonry or concrete. Masonry and concrete can absorb water through capillary action, the same mechanism by which a sponge absorbs water. In hot, humid weather, moisture from the air also condenses on concrete and masonry surfaces (which often stay cooler than the ambient temperature). Over time, this moisture can cause untreated wood to rot or attract termites. Because treated wood does not deteriorate in the presence of water, it's required by most building codes in these locations.



A pitched roof provides built-in protection from water.

Built-in protection from fire

There are two built-in measures that building codes require to help protect wood-framed houses from fire. The first is to keep the wood frame from touching fireplaces and chimneys. Codes generally require a 2-in. clearance from all sources of combustion. The second measure required by building codes is to use fireblocking. By closing off cavities in walls, fireblocking restricts the supply of oxygen to potential fires. Fireblocking the wall cavities at the floor and ceiling levels also helps keep fire from spreading from floor to floor.

Anticipating Subsequent Work

Along with the ability to build a sound and durable structure, frame carpenters have to anticipate the needs of all the trades that follow. Not long ago, carpenters framed houses, then they and other craftsmen fit their materials to the standing structure. Nowadays, it's quite the opposite. To a large degree, carpenters build frames to fit the materials that will cover them.

Modular coordination

Like modern masonry materials, most of the materials that cover house frames are manufactured in dimensions that fit an industry-wide system called modular coordination. The basic unit of this system is a 4-in.-square module, and most building materials are manufactured in multiples of this module. Plywood and drywall, for example, are manufactured in sheets that are 48 in. wide and 96 in. or 144 in. long. To make the frame fit the materials, carpenters generally lay out framing members (studs, joists, rafters, etc.) at 16-in. or 24-in. intervals. This process minimizes cutting and saves time and material.

In addition to conforming to the modular system, frame carpenters have to anticipate and allow for a large number of nonmodular materials. Among these are doors, windows, plumbing fixtures, plumbing lines, and heating and venting ducts.

Backing and blocking

Frame carpenters also have to provide solid nailing surfaces for all the materials that will later be attached to the frame. To do this, they have to visualize how these materials will be attached and install backing (added lumber for inside corners) and blocking (short pieces of lumber nailed between studs and other framing members) at strategic locations throughout the frame.

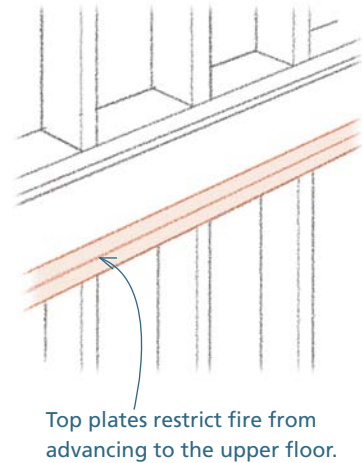

Top plates restrict fire from advancing to the upper floor.

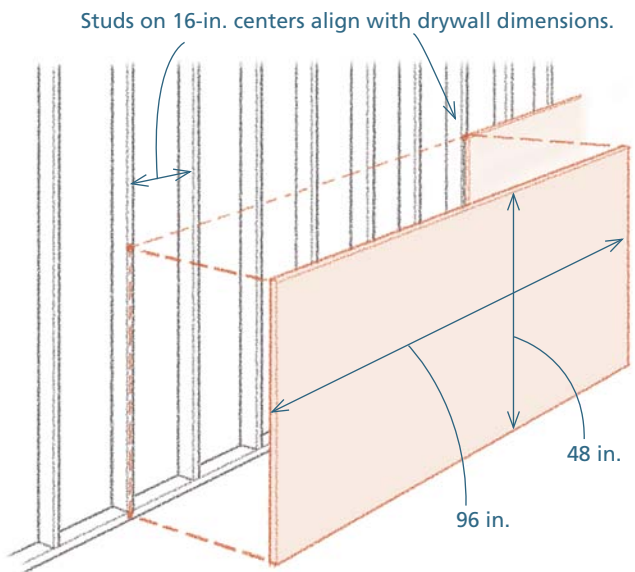

Studs on 16-in. centers align with drywall dimensions.

Blocking installed between studs

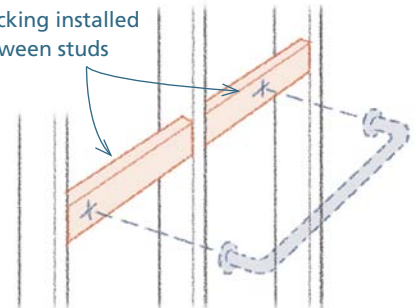

The Platform Frame

There are many ways to build the shell of a house, but the most common, by far, is the platform frame. Because it accounts for more than 90% of the new single-family homes in the United States, the platform frame is the focus of this book. Most of the building techniques used to build platform-framed houses are readily transferable to other systems.

The platform frame is a relatively new construction system. It is a refinement of the balloon frame, which was developed in the American West in the mid-1800s. In the 1930s, the platform frame emerged as a modification of the balloon frame. The main innovation in the platform frame was the length of the wall studs. In a two-story balloon frame, the studs extend from the mudsill, past the second

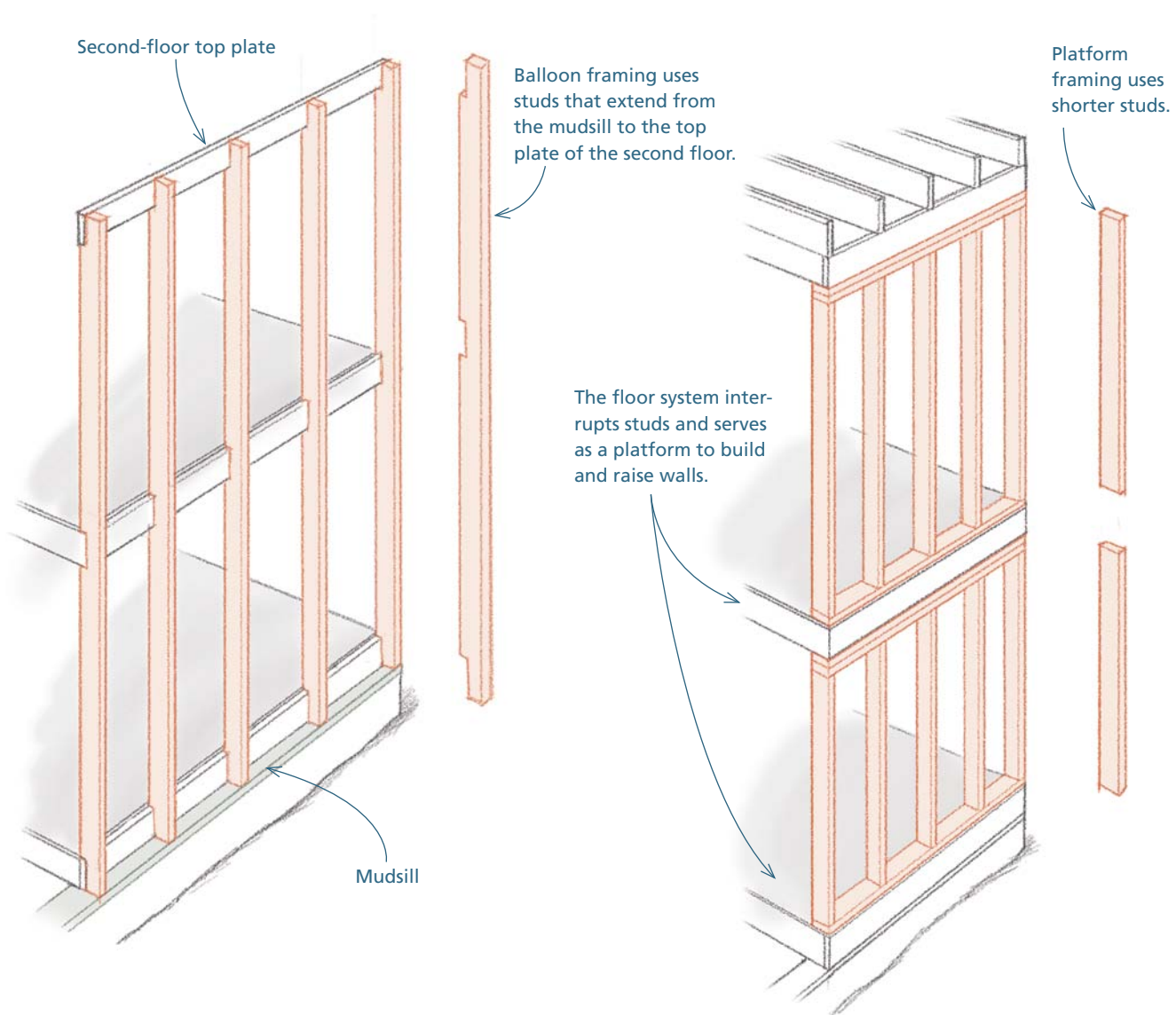

floor, and up to a top plate just below the eave or rake of the roof. The studs often have to be 16 ft. to 20 ft. long. The intervening floors bear on ledgers that are set in notches cut in the studs.

In a two-story platform frame, carpenters begin by building a floor system, which bears on the mudsill. This floor serves as a platform upon which the walls for the first story are built. After building, raising, and bracing the first-story walls, a second floor is built across them. This floor serves as a second platform upon which the walls for the second story are built. The ceiling at the uppermost level serves as a final platform and is often used to stand on as the carpenters assemble the roof frame.

Building Floors

When you build a floor, you have to do a lot more than provide a level surface to walk on. If the top of the foundation is out-of-level or out-of-square, the floor system provides an opportunity to partly or completely remove these flaws. You also have to think far ahead in the construction process. You need to take into account: the structures that will be built through the floor; the structures that will be built on top of the foundation; and the locations of plumbing fixtures and heating and air-conditioning lines. This section examines these concerns as it describes the construction of a typical framed floor.

Install the Mudsills and Girders

STEP 1 Measure the foundation and check for square

1 Sight along the foundation walls to see if they are straight.

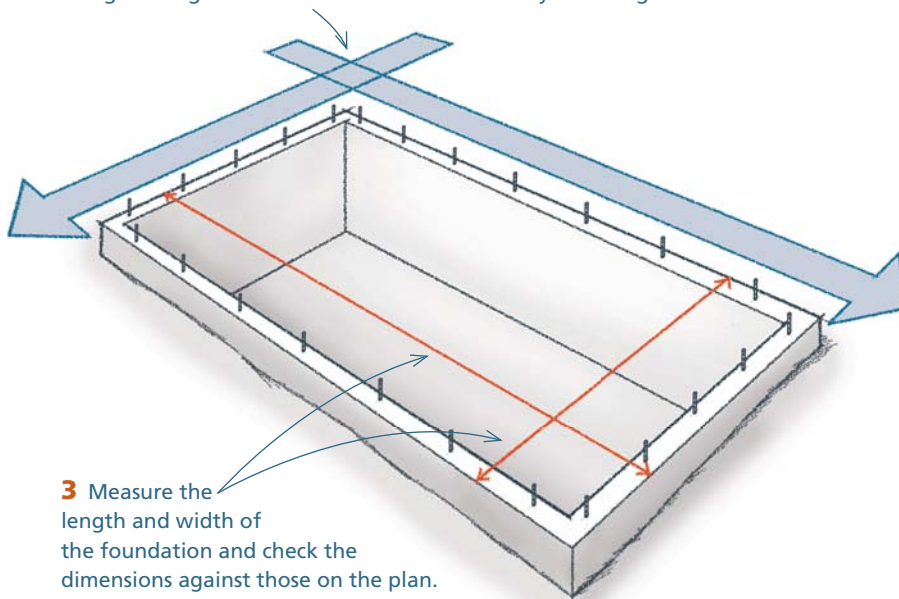

2 Measure across the diagonals; if the diagonals are equal, the foundation is square.

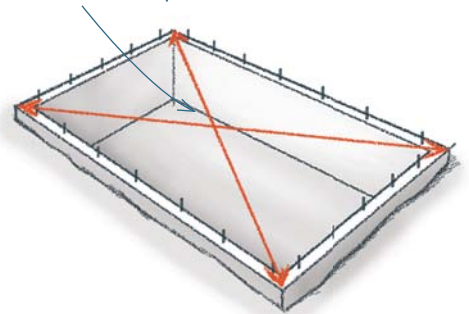

Materials Used in Platform Frames

● LUMBER

The most prevalent material in platform frames is lumber, often called “solid-sawn lumber” to differentiate it from other wood products. Lumber is used to frame floors, walls, ceilings, and roofs.

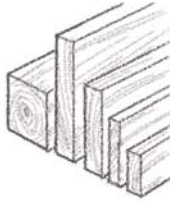

● ENGINEERED LUMBER

Engineered wood products are present in almost all new frames. Unlike sawn lumber, they are manufactured components made from lumber, wood veneer, or wood strands.

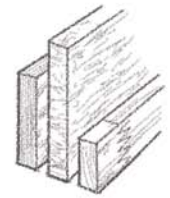

Plywood and OSB

Plywood is manufactured by gluing thin laminations of wood into panels. Another kind of manufactured panel, the oriented strand board (OSB) panel, has recently captured much of the market for structural wood panels. OSB is manufactured by gluing together strands of wood rather than veneers.



Structural composite lumber (SCL) and glulams

Engineered lumber is manufactured from small pieces of lumber, wood veneers, and strands of wood that are fused together with waterproof glue. Among these timber substitutes are three types of structural composite lumbers: laminated veneer lumber (LVL), laminated strand lumber (LSL), and parallel strand lumber (PSL). Another kind of timber substitute is the glued laminated timber (Glulam). Manufactured under controlled conditions, these products are stronger, straighter, and more stable than sawn lumber.

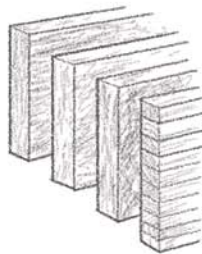

Wood I-joists

Wood I-joists are comprised of top and bottom flanges joined together with a web. The top and bottom flanges can be made out of sawn lumber or SCL. The web is made of plywood or OSB. Wood I-joists are used as floor and ceiling joists and, less commonly, as rafters in roof framing. I-joists are straighter and have less deflection than solid-sawn joists.

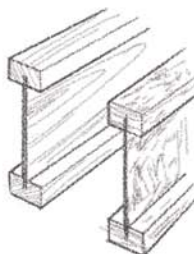

● TRUSSES

Engineered prefabricated trusses are made of solid-sawn lumber connected by metal plates. The wood must be carefully graded and the metal plates engineered to withstand the loads at the joints. Trusses can be used as floor joists and as structural components for roof/ceiling systems. Because they save lumber and can be installed quickly, roof trusses are used in two-thirds of the new houses built in the United States.

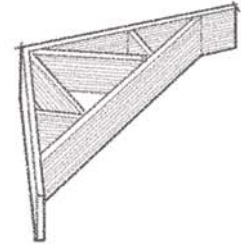

● STEEL

Nails

Since the first balloon frame was built in the 1830s, nails have been an essential part of light wood-frame systems. They are a vital part of the structure and play a particularly important role in resisting live loads on the house. Building codes specify the size, spacing, and quantity of nails in key locations on the frame. These nailing schedules are inspected and enforced by building inspectors.



Steel connectors

Steel bolts and ties are used to tie frames to foundations. Steel joist hangers are used to support floor joists.

Manufactured metal connectors and straps are available for a wide variety of special purposes. Among these are seismic hold-downs, plate-to-truss ties, and plate-to-rafter ties. These are often required by local codes to help the frame resist live loads. In addition to these manufactured steel connectors, designers sometimes specify custom-fabricated steel brackets and connectors.



Structural steel

Structural steel girders, beams, and flitch plates (flat sheets of steel sandwiched between two pieces of lumber) are sometimes integrated into platform frames to support large loads. Entire frames, similar in construction to wooden platform frames, can be built from light steel studs, plates, floor joists, and rafters. Occasionally, these components are combined with wood framing.

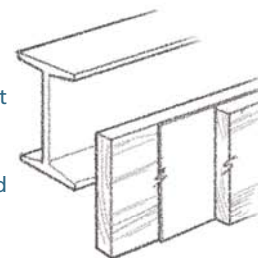

STEP 2 Mark the location of the mudsill

1 Measure the distance between the outside surfaces of the long walls. If they're the right distance apart, measure and mark the width of the mudsill in from the outside face of the foundation walls.

2 Snap a chalkline from mark to mark to lay out the inside edge of the sill.

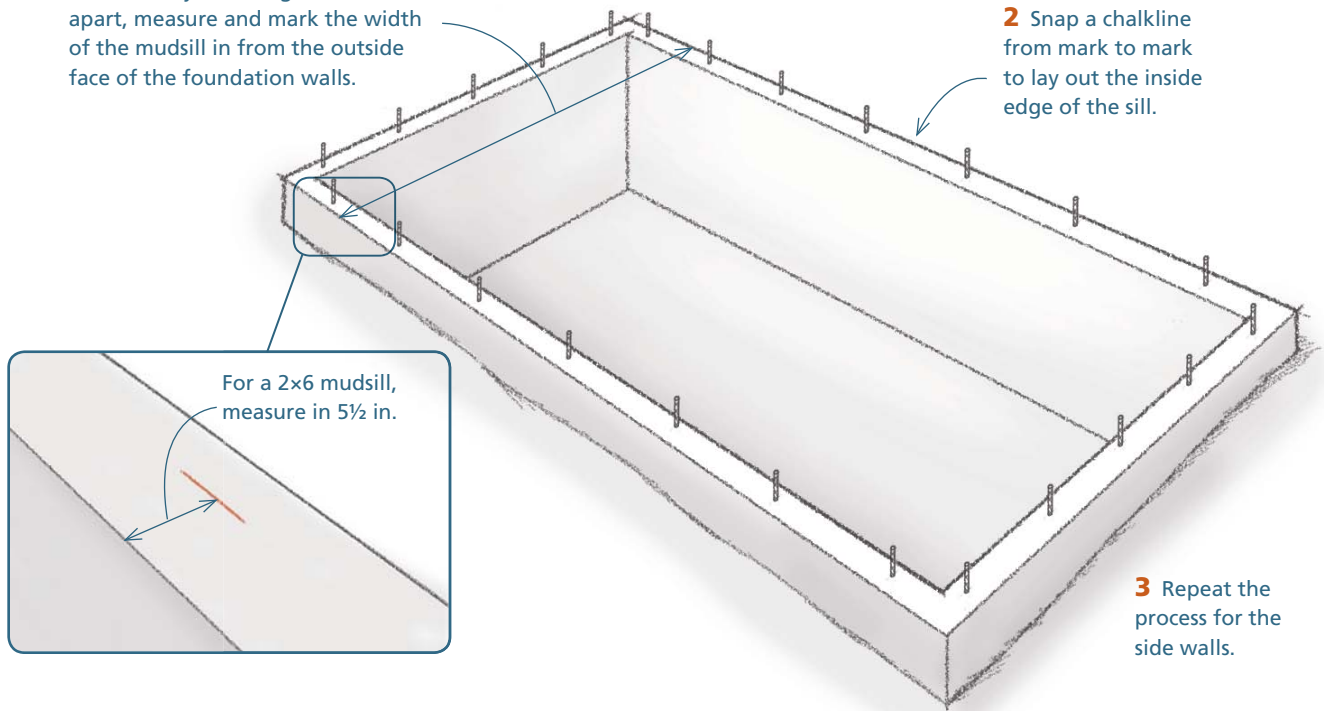

3 Repeat the process for the side walls.

STEP 3 Check the foundation for level

Set up a transit or laser and check the top of the foundation for level. Begin by checking the elevation of the corners. Note which, if any, is the high corner. After checking the corners, place 2x4 gauge blocks at each corner and stretch a line over the blocks.

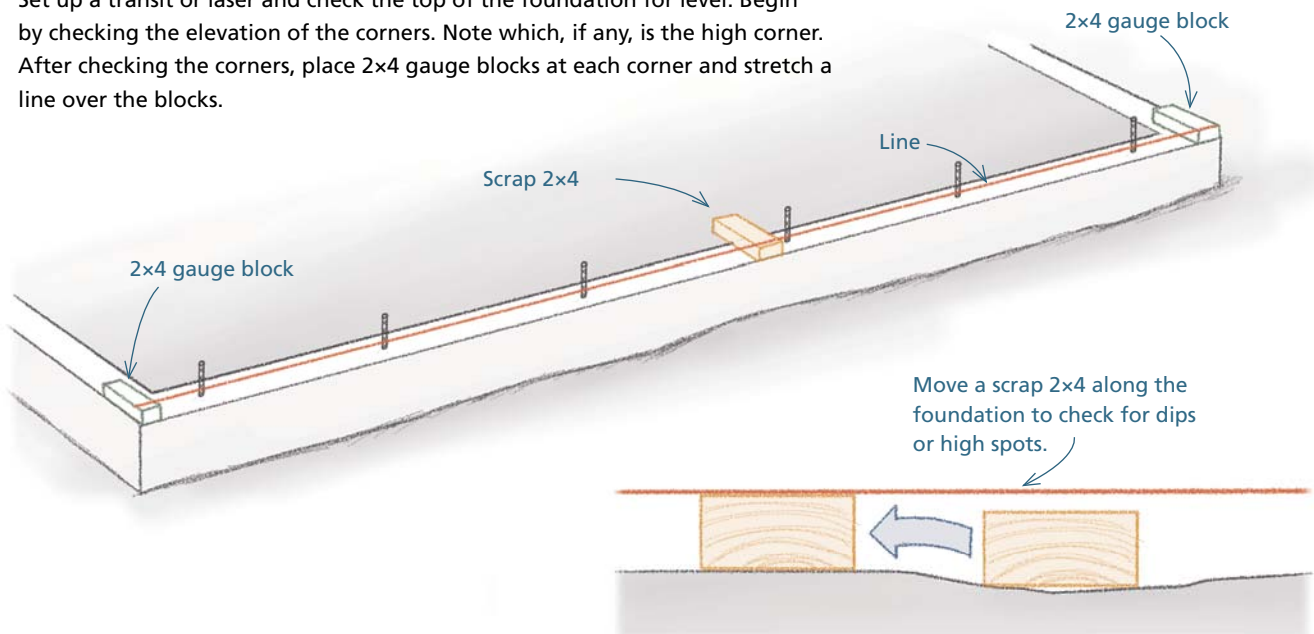

STEP 4 Correct flaws

After checking the top of the foundation for deviations from flat and level and establishing a reasonable set of tolerances, you can do a couple of things to overcome any flaws.

• FILL LOW SPOTS

Use shims cut out of treated wood, glued in place with construction adhesive at 12-in. to 24-in. intervals.

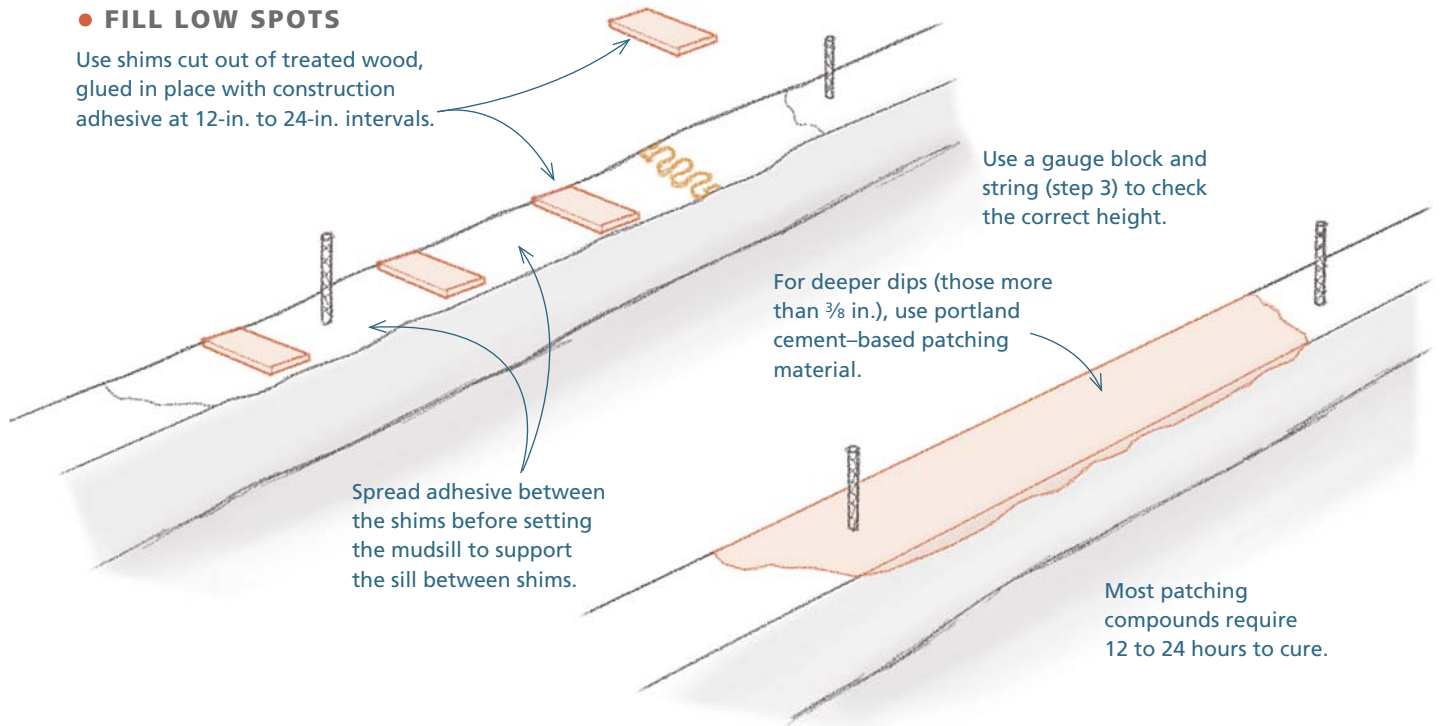

• REMOVE HIGH SPOTS

Remove small high spots along the top of the foundation with a grinder.

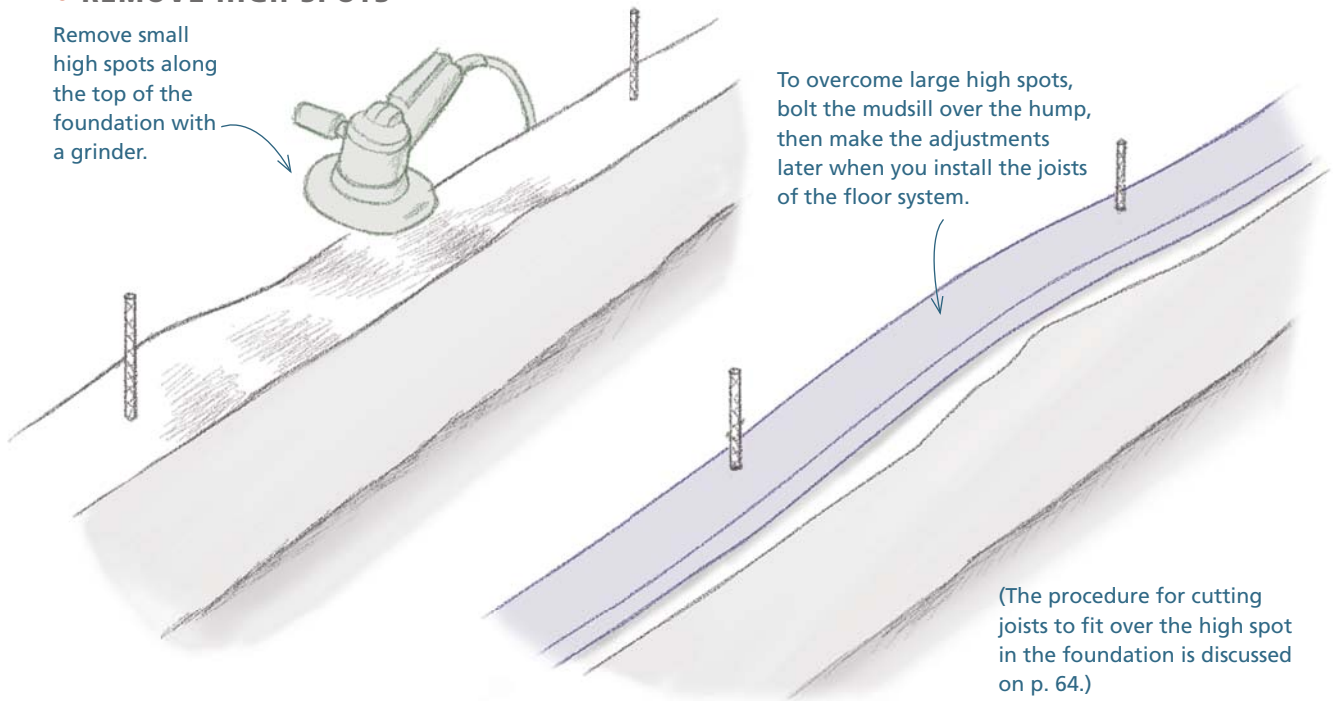

Make Adjustments in the Mudsill Layout

If the walls of the foundation are not straight, or the dimensions are off, you can partly or completely correct these flaws as you lay out the mudsills. If the walls are not the right distance apart or if they deviate from parallel, adjust the mudsill layout to bring the width partly or completely into the proper alignment. You can easily make a 1-in. correction at this point. If you need a larger adjustment, leave some of it for the next stage in the job.

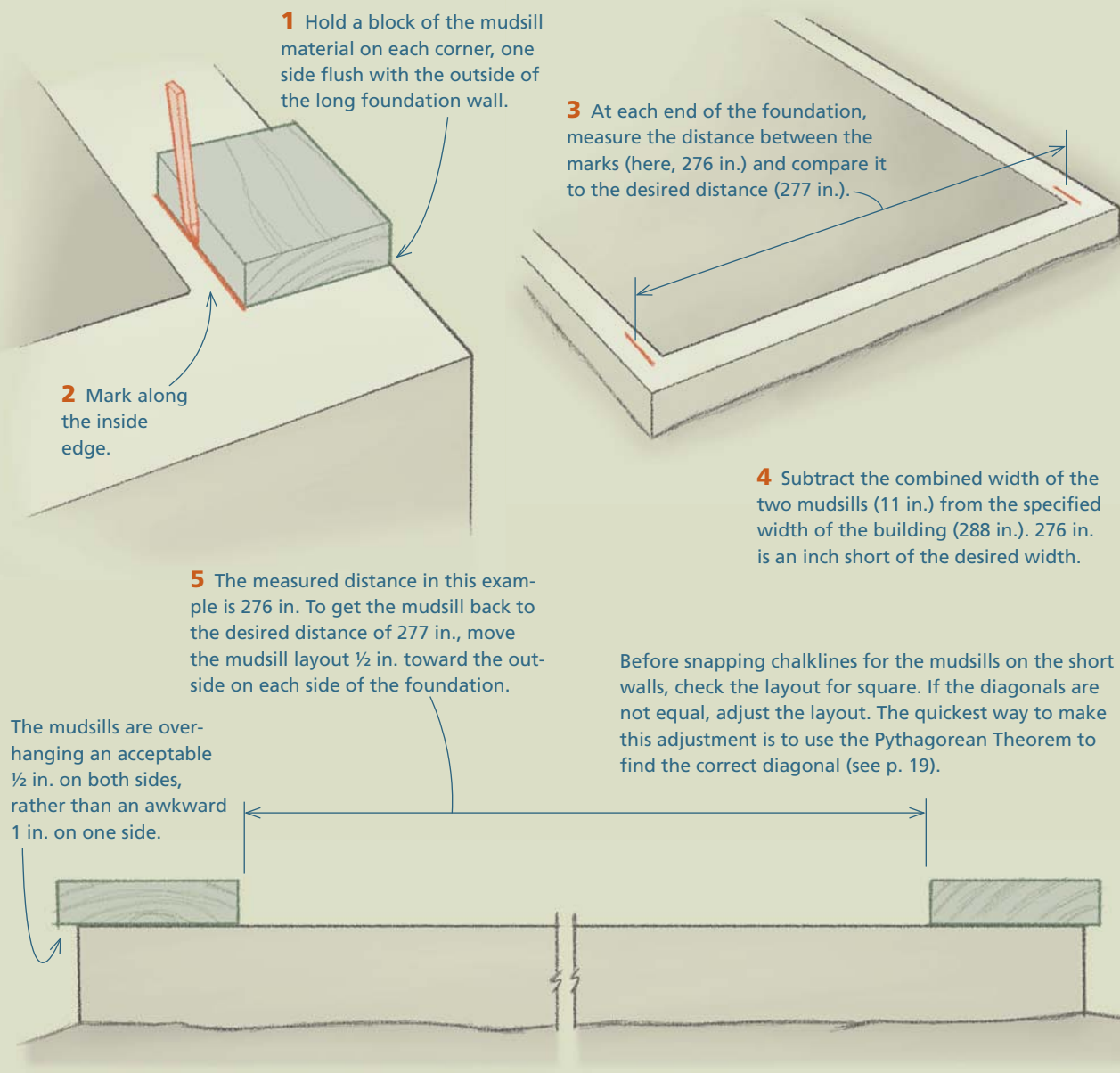

STEP 5 Attach the mudsills

Each mudsill must be drilled accurately, then threaded over the bolts or straps embedded in the top surface of the foundation. Once the mudsill is in place, you can mechanically attach it with either a washer and a nut (if you have bolts) or nails (if you have straps).

1 Install a layer of sill seal or caulk to prevent air infiltration in the seam between the mudsill and the foundation.

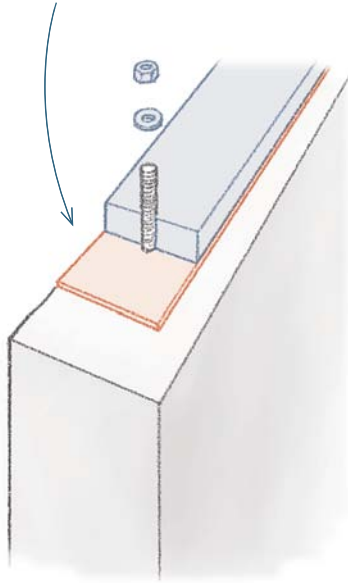

2 Place the mudsill on top of the foundation against the bolts, and mark both sides of the bolts along the length of the mudsill with a square.

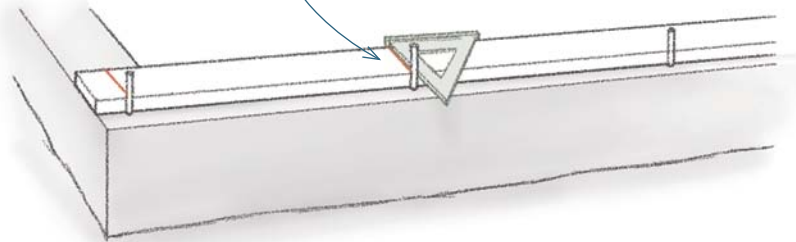

3 Mark the distance from the snapped line on the foundation to the edge of the bolt. Transfer that measurement to the mudsill; add the thickness of the bolt.

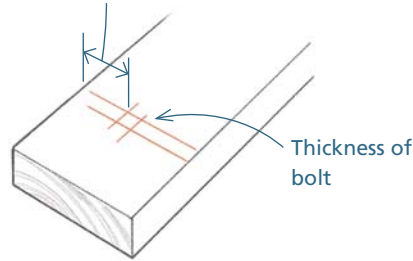

4 Drill through the center of the marks.

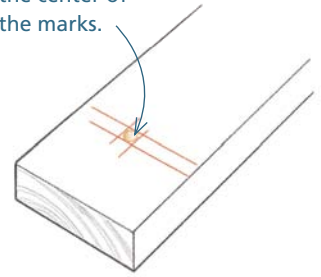

Install Girders or Basement Bearing Walls

On most houses, the floor joists cannot span the distance between the outside walls of the foundation. There is typically some sort of intermediate support system at or near the center of the foundation. These support systems can be a girder bearing on masonry or concrete piers, a girder bearing on posts, or a basement bearing wall.

● GIRDER LOCATION

The girders under the floor joists

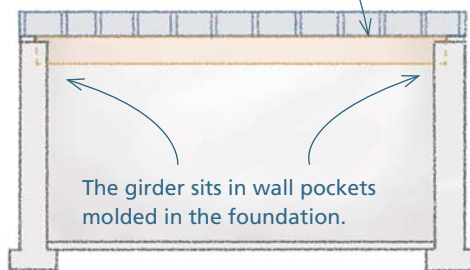

Girders flush with the floor joists

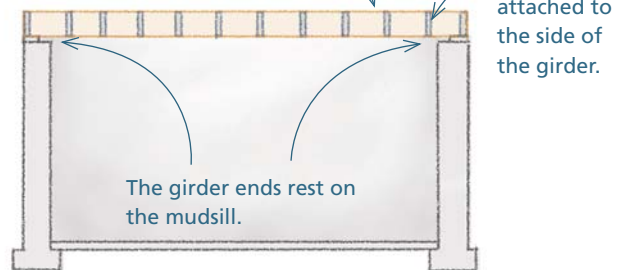

● GIRDERS ON PIERS OR POSTS

If you're building the girder over masonry or concrete piers, check the heights of the piers by stretching a string across the foundation above the piers.

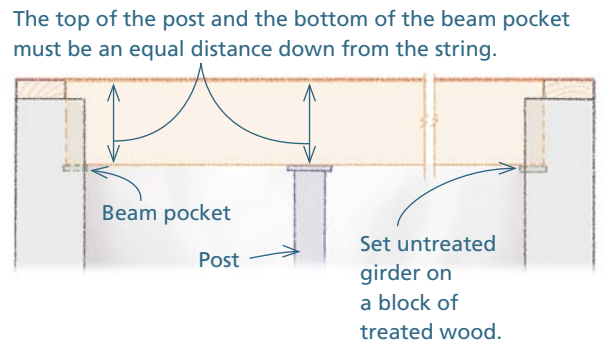
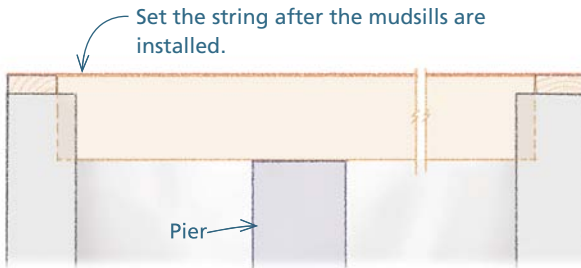

● BASEMENT BEARING WALLS

Concrete floors typically end up with some dips and high spots. To avoid transferring these flaws to the top of the bearing wall, you should custom-cut the studs along the length of the wall.

1 Set a string on top of the mudsills that extends from one end of the foundation to the other. Place the string even with one of the top outside edges of the bearing wall to be built.

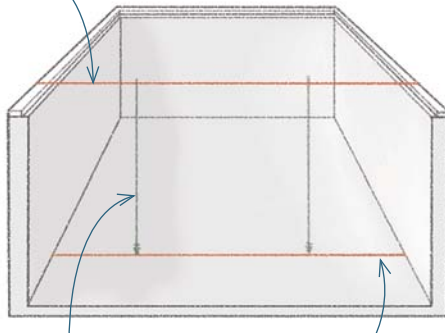

2 Transfer the position of the string to the basement floor.

3 Snap a chalkline on the floor to lay out the position of the bottom of the wall.

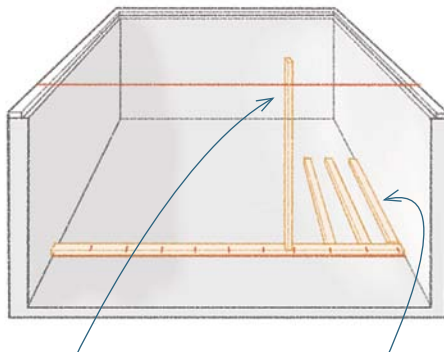

6 At each stud location, stand a stud on the plate and mark the top at the string line.

7 Lay the stud perpendicular to the plate at the stud location and repeat the process.

4 Cut and fit a treated plate along the chalkline.

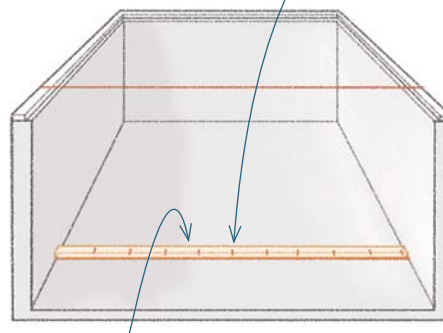

5 Lay out the positions of the studs on the plate.

8 Cut the stud 3 in. down from the marks to allow for a thickness of double the top plate.

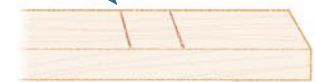

9 Return each stud to its proper place in the layout.

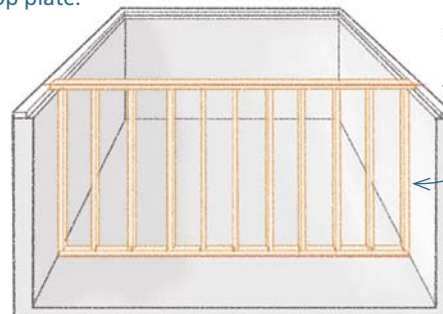

10 Build and install the wall using the techniques described on pp. 76–83.

Install the Joists

The following steps do not represent a strict order of completion. If you have a crew, many of the steps can be performed simultaneously by different members of the crew.

STEP 1 Review the plan

When you review the plans, look for critical structural details. Among these details are: the locations of the bearing walls that will later be built on the floor; point loads that will later bear on the floor; and all large openings that will have headers, such as the openings required for a stairwell or a chimney. Note these details on the plan or in your notes; they will affect how you lay out the floor joist.

STEP 2 Sort and crown the joist material

The crown is the high side of the midsection of a board when it's set on edge. Lumber deforms as it dries, and few pieces stay as straight as they were the day they were sawn. To get the most out of this dimensionally imperfect material, you have to inspect and sort it as you use it. Placing the crown up on all the floor joists serves three functions.

- It makes the surface of the floor more even than a floor where a "crown-up" joist is installed next to a "crown-down" joist.
- Placing the crown up helps the joists resist midspan deflection.
- It compensates for the long-term sagging of the joists; a crowned floor joist actually gets straighter as it sags.

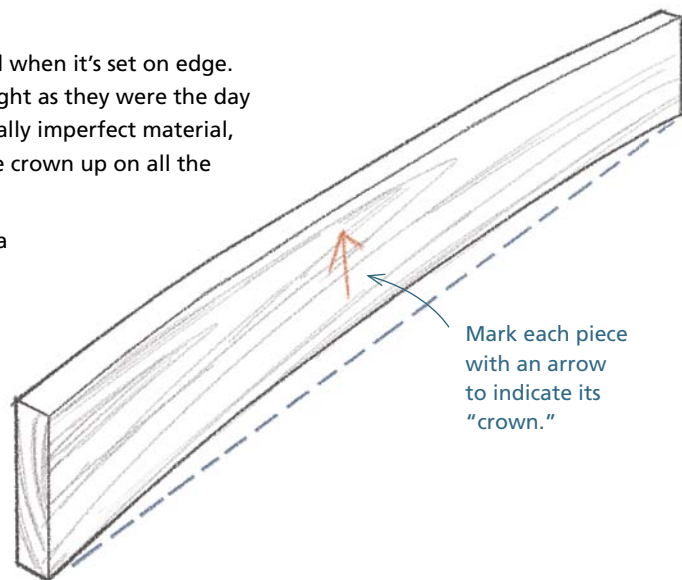

● SORT FLOOR FRAMING MATERIALS INTO THREE PILES

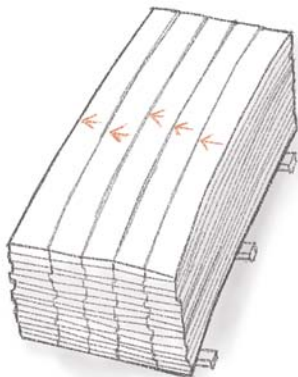

Straightest pieces for the rim joists

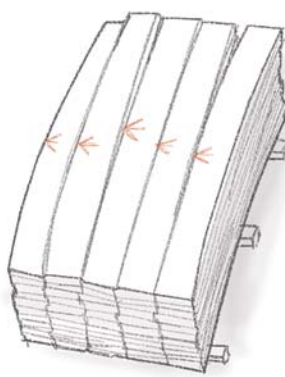

Mildly crooked pieces for floor joists



Worst pieces for headers, blocks, and shorter pieces

STEP 3 Lay out joist locations on the mudsill

Divide the layout into two phases. In the first phase, mark the joist locations for critical details. When you get these joist locations marked, go back and mark the rest of the joist locations at standard 16-in. or 24-in. intervals (or 19.2 in. if the designer wants five structural members for each sheet of plywood/OSB).

● LAYING OUT THE CRITICAL DETAILS

Lay out the walls that will run parallel to the floor joists on the mudsill. Give special attention to the bathroom walls. Make sure that the bathroom walls are the right distance apart.

Standard tubs are 30 in. by 60 in. The center of the drain will be 12 in. from the wall; at the side of the tub, the center will be 15 in. from the wall. On the mudsill, mark the center of the drain and then mark 2 in. out in both directions.

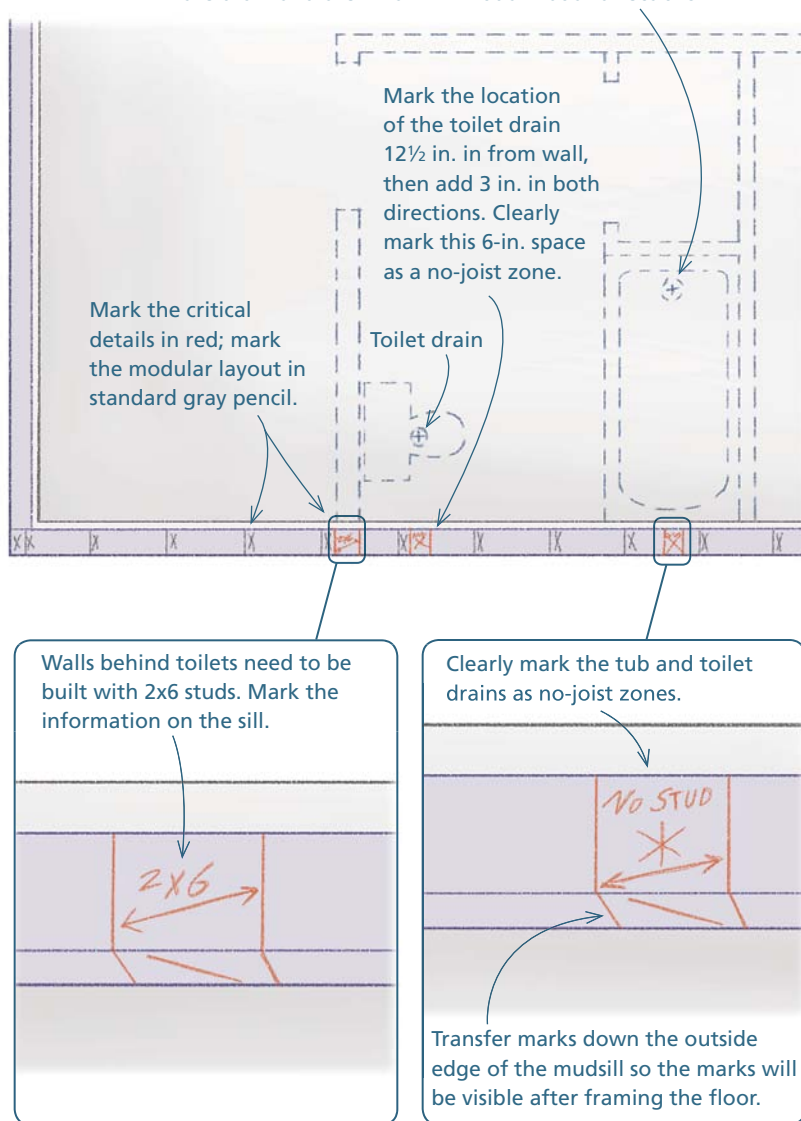

TOP TIP

Cumulative Gain or Loss

.....

You should be able to lay out a wall by measuring over 16 in., marking, and then repeating the process. In practice, however, this method often results in cumulative gain or loss. If your measurement is consistently $\frac{1}{16}$ in. long, for example, your layout can grow by 1 in. in 22 ft. To avoid cumulative error, use a steel tape and pull the measurements for the layout from one reference point (two, if the length of the wall exceeds the length of your tape measure).

.....

● MARKING THE MODULAR LAYOUT

To get the panels to “break” or end on the center of the joists, you need to get the center of the sixth joist (when laying in 16-in. intervals) exactly 96 in. from the edge of the floor. The layout, however, marks the edge of the joist, which is $\frac{3}{4}$ in. over from the center of the joist. This means that the sixth joist needs to be $95\frac{1}{4}$ in. from the edge of the floor.

The most common spacing is 16 in. on center.

Full sheets of plywood or OSB will break evenly on the floor joists.

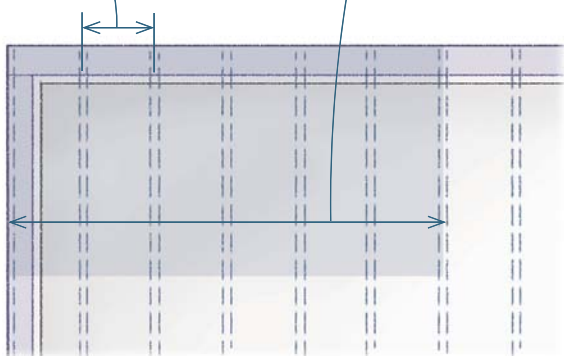

Hook the tape over the corner of the mudsill and mark at $15\frac{1}{4}$ in.

Reset the tape at that point and mark every 16 in.

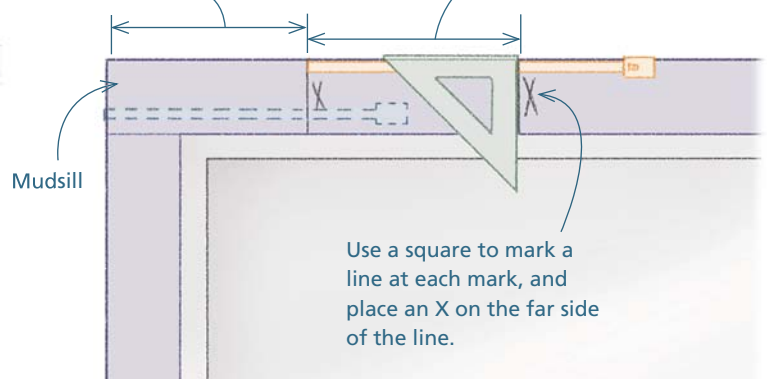

Use a square to mark a line at each mark, and place an X on the far side of the line.

Where the plan calls for stairwells or chimneys, a double trimmer joist on each side of the opening in the floor is required by code. These openings are difficult to move or enlarge after they are built, so it's important to lay out the locations of these joists carefully. (See chapter 11 for more on laying out stairwells.)

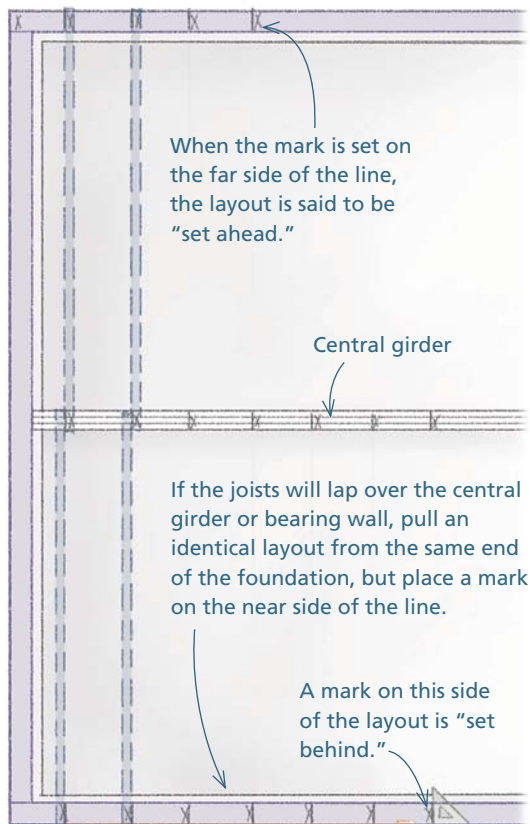

When the mark is set on the far side of the line, the layout is said to be “set ahead.”

Central girder

If the joists will lap over the central girder or bearing wall, pull an identical layout from the same end of the foundation, but place a mark on the near side of the line.

A mark on this side of the layout is “set behind.”

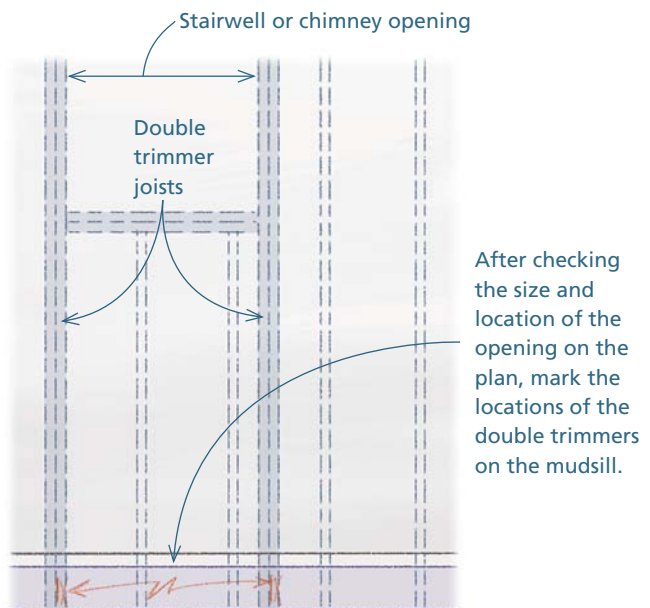

After checking the size and location of the opening on the plan, mark the locations of the double trimmers on the mudsill.

STEP 4 Install the rim joists

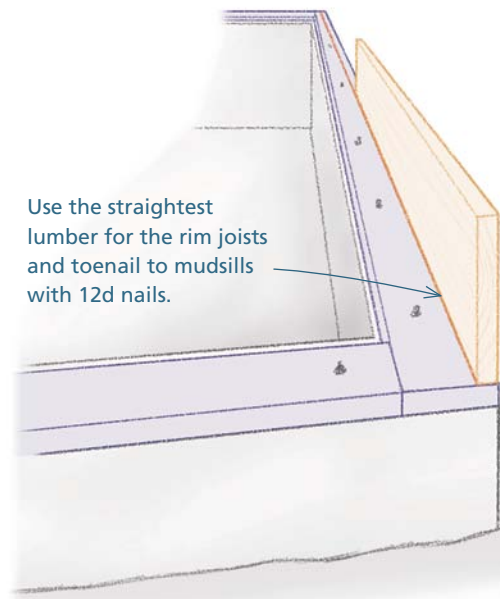
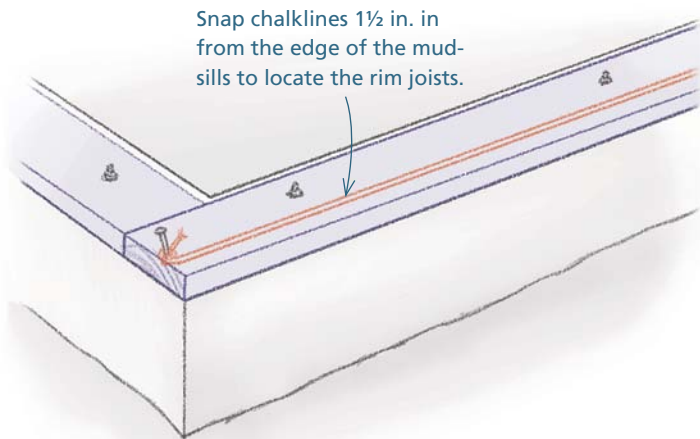

WAYS OF WORKING

Going over High Spots in the Foundation

If you have to run the mudsill over a high spot in the foundation, you'll need to cut the bottom of the rim joist to fit around the hump in the mudsill.

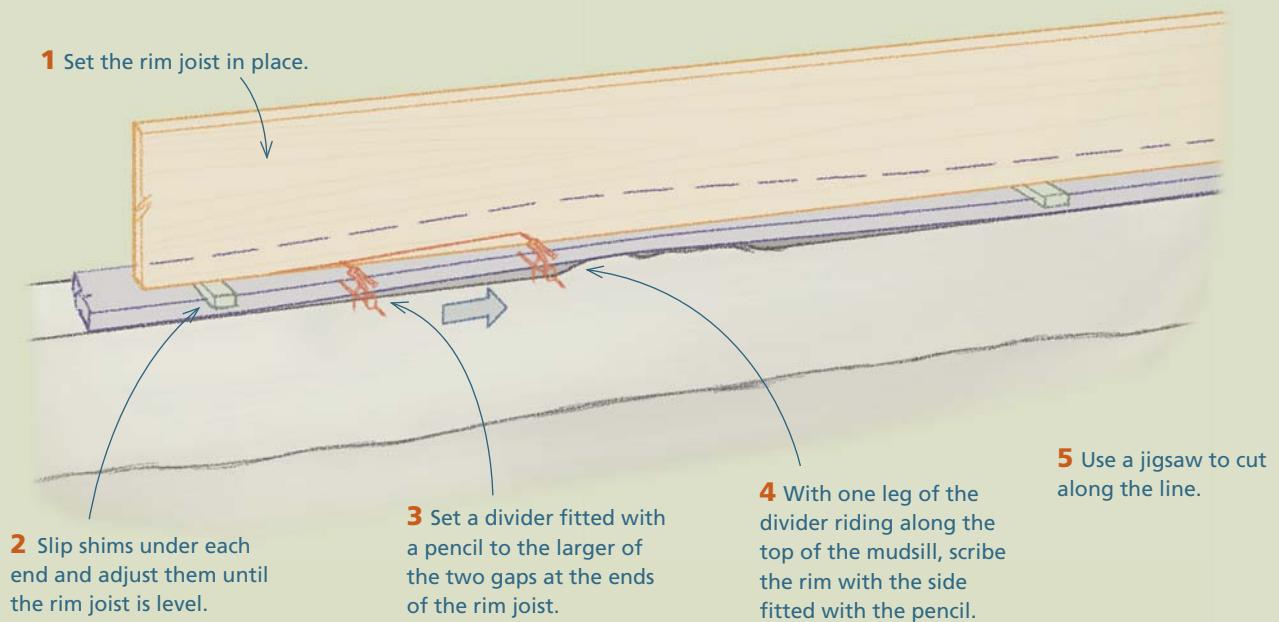

STEP 5 Install the joists

1 Set a string to determine if the girder or bearing wall is straight. If necessary, use braces to hold it straight.

2 Use a square to mark plumb lines on the inside of the rim joists at the layout lines on the sill.

4 Align the joist edge with the plumb line. Nail through the outside of the rim joist into the end of the joist.

3 Place each joist on the layout line on the mudsill and push it tight to the rim joist. Toenail the bottom of the joist to the mudsill.

5 At the other end of the joist, toenail the joist to the girder or bearing wall. Repeat this process for all the joists.

7 Install blocks between overlapping pairs of joists to hold the ends plumb. Blocks should be the full depth of the joist material.

6 Where joists overlap in the middle, nail them together.

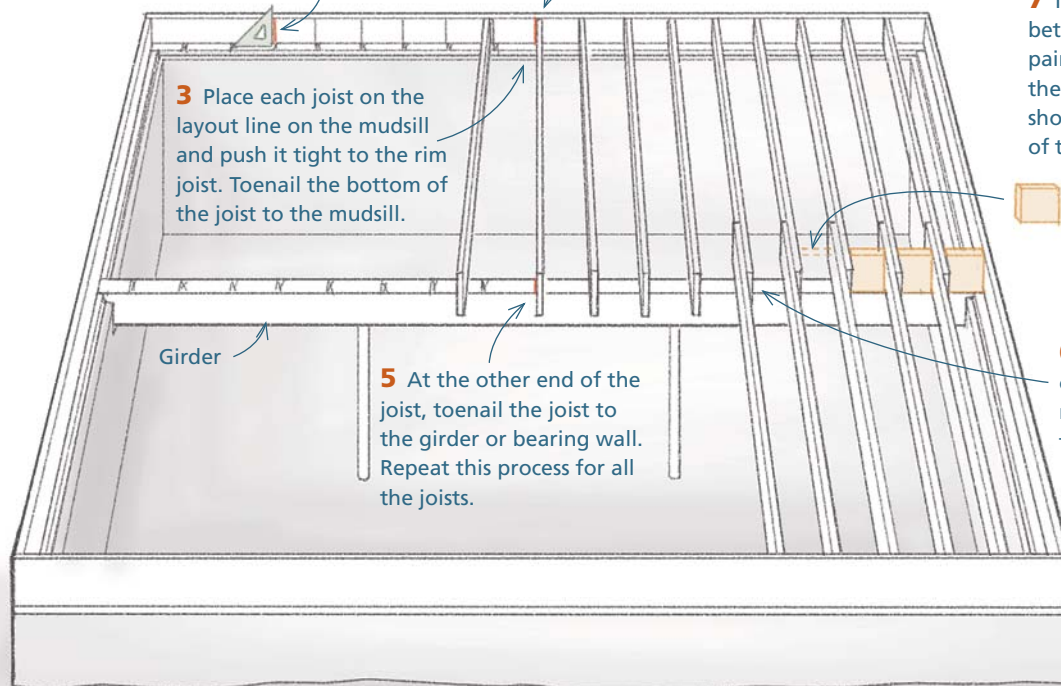

STEP 6 Install the sheathing

The most common sheathing material is $\frac{3}{4}$ -in. tongue-and-groove plywood or OSB. This section provides the procedures for its installation.

● BASIC LAYOUT

1 Measure 48 in. from the edge of the framed floor.

2 Snap a chalkline that runs perpendicular to the floor joists.

3 Run the first row of sheathing along this line. Put the groove side of the panel on the line.

4 After running the first row, offset the second row 48 in.

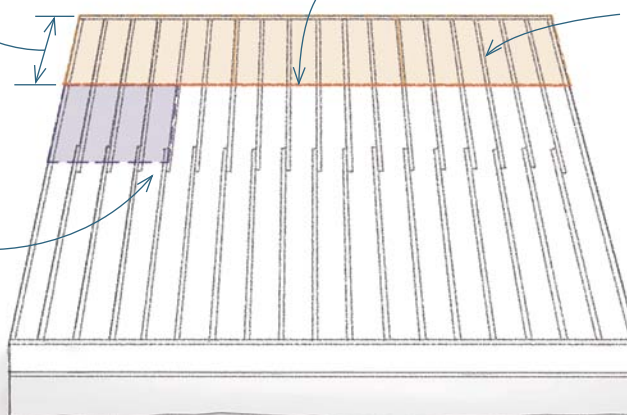

● **ADHESIVE**

Spread a generous ½-in. bead of construction adhesive on each joist.

Do not spread adhesive beyond the joists that will be covered by the sheathing.

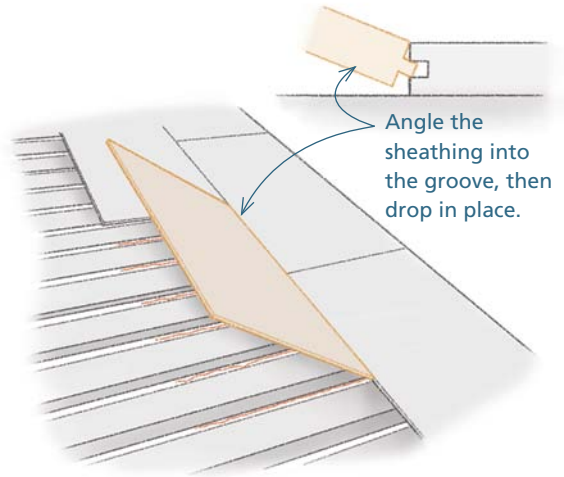
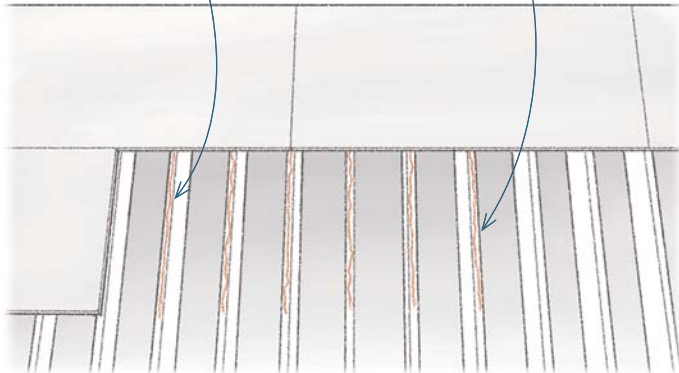

Angle the sheathing into the groove, then drop in place.

● **EDGES**

To allow for expansion, drive 8d nails along the end of the previously installed panel. Butt the end of the next panel against this nail.

Flatten any upward bowing parts along the edge of the panel.

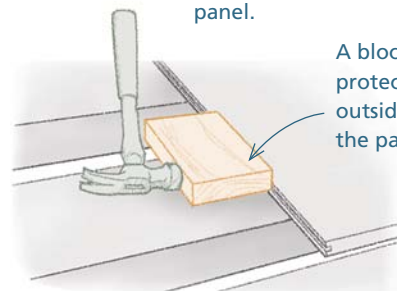
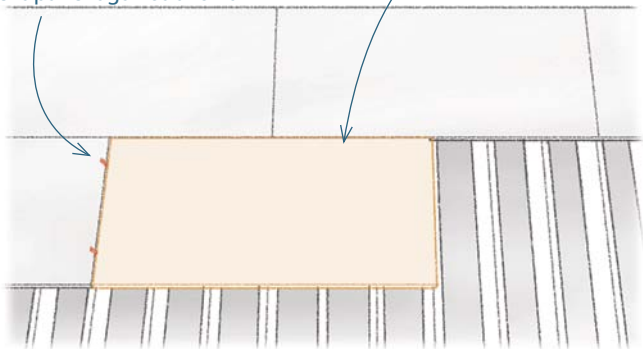

Force the tongue of the panel into the groove of the adjacent panel.

A block of wood protects the outside edge of the panel.

● **NAILING SCHEDULE**

The nailing schedule for a ¾-in. wood structural panel typically calls for 8d coated sinkers every 6 in. at the edges of the panel . . .

. . . and 12 in. at the intermediate supports.

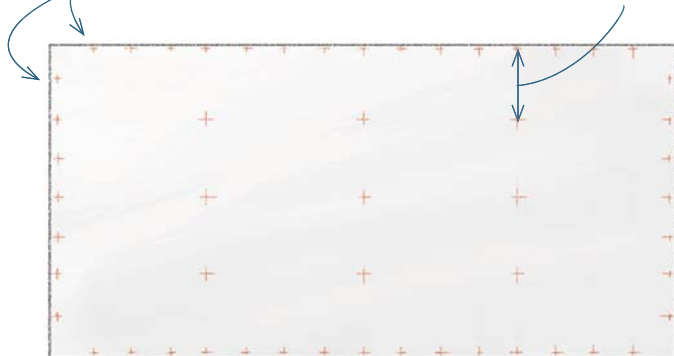

TOP TIP

Cut Out the Bad Spots

.....
 Once in a while, the tongue or groove of a panel is mangled or deformed, making it hard to insert the tongue into the groove. When you see a bad spot, clean it up with a chisel or utility knife before installing the panel. Doing so will make the installation go much more smoothly.

Joist Details

• ALLOW FOR WIRING

Building codes require that bearing walls that run parallel to the floor joists rest on a double joist (two joists nailed together). To accommodate electric wires and plumbing lines into the wall cavity from underneath, codes also allow the two joists to be separated by blocking.

Double joist separated by solid blocks that equal the depth of the joists and are spaced no more than 4 ft. apart

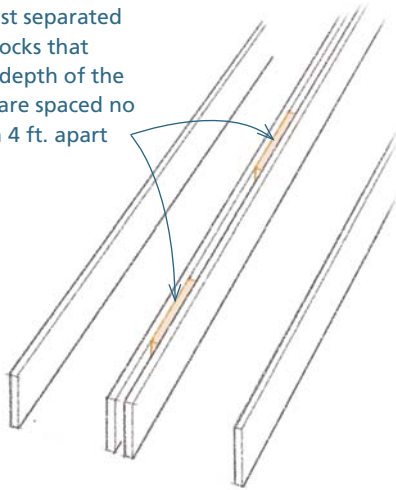

• BRIDGING

When using solid-sawn lumber, midspan bridging is not required by most building codes. It adds little structurally and is a common source of floor squeaks. It is not recommended. Midspan bridging is required for floor joists that exceed 2x12 in depth. The purpose of the bridging is to keep the bottom of the joist from moving laterally. If using engineered wood products for the joists, follow the manufacturer's directions for bridging.

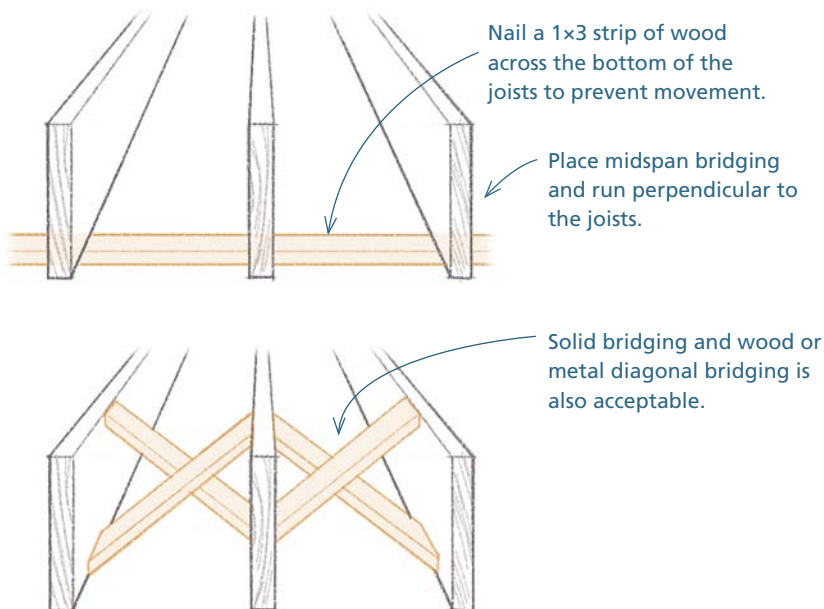

• RUNNING JOISTS OVER A HIGH SPOT

Where the rim joist has been cut to fit a high spot, you'll have to notch the ends of the joists slightly.

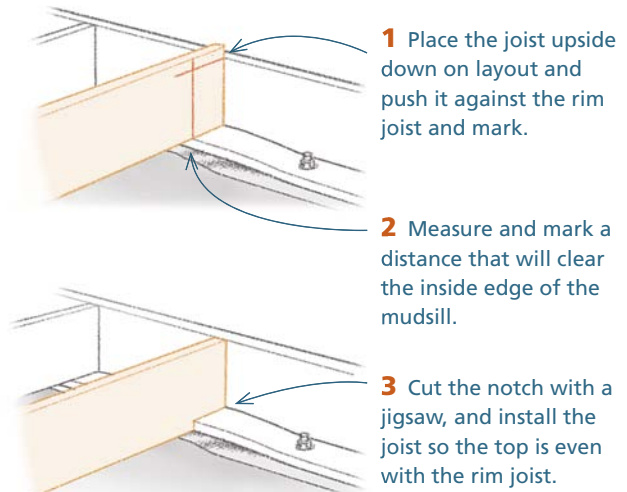

• DRILLING AND NOTCHING

Building codes permit the drilling and notching of sawn lumber joists. There are, however, specific regulations concerning the size of the holes and notches and their placement along the length of the joist. These are the restrictions specified in the International Residential Code (IRC).

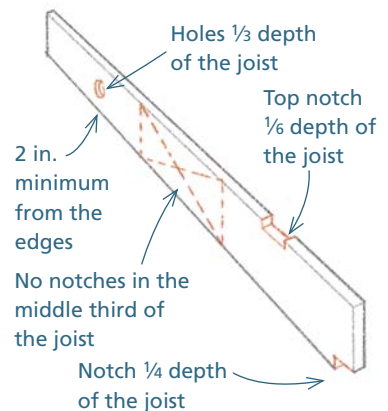

If using engineered wood products for floor joists, check with the manufacturer for information on permissible drilling and notching.

Using Engineered Lumber for Floor Systems

In residential construction in the United States, more than a third of the floors in new houses are built with engineered lumber (EL). Because there are several advantages to these products, their market share is growing and will continue to grow for the foreseeable future.

Advantages of EL

Unlike sawn lumber, which is simply harvested from nature, engineered lumber is manufactured under controlled conditions. Sawn lumber is typically graded visually, a process that is subject to human error. EL, in contrast, is mechanically tested for structural properties, which provides for more reliable structural performance than sawn lumber.

Being a natural product, sawn lumber has defects, such as knots and uneven grain. As it dries, it shrinks. Because the grain is uneven, this shrinkage causes boards to deform and split. EL is uniform and dimensionally stable. It stays much straighter than sawn lumber, which results in straighter, more even, and quieter floors.

Another advantage of using EL for floors is that it can span larger openings than sawn lumber. This allows for larger rooms and more open floor plans.

A final reason for the increased use of EL is the fact that it can be made up of small pieces of wood or even strands of wood. This has environmental implications because fewer large trees are needed for a given floor system than would be required using sawn lumber.

Engineered Systems

Working with engineered lumber requires more organization and planning than working with sawn lumber. For the most part, you build according to an engineered system that's tailored to the job at hand. These plans are provided by the manufacturer when you order a floor package through your supplier.

This is different than working with sawn lumber, where you often build to generic requirements that are written into the code. Carpenters and builders are often able to generate an acceptable plan for a basic structure using the span tables for sawn lumber in the building code. If you want to use EL, however, you have to use plans developed by the manufacturer. Building inspectors typically ask for these plans when they inspect your job. In addition to specifying the size and placement of EL components, the plan includes the required hardware, nailing schedules, bracing requirements, and other details.

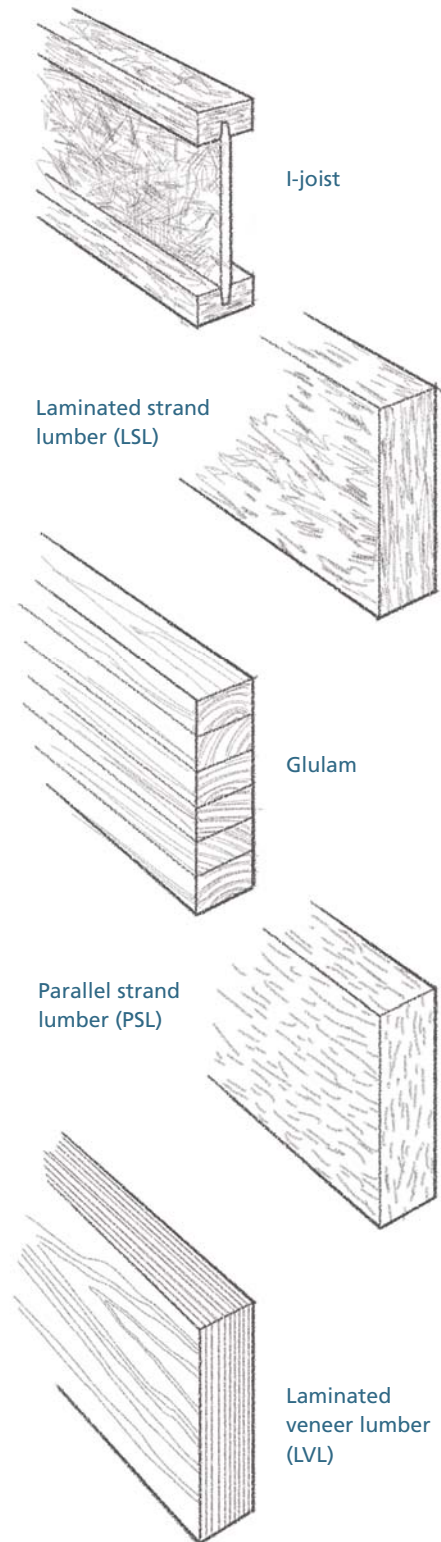

Mixing EL with Sawn Lumber

Sawn lumber shrinks more than most engineered lumber. Because of this, combining the two materials in some locations can cause problems. The intermixing of EL and sawn lumber is most problematic in floor systems. In platform framing, the walls are built on the floor. If some parts of the floor frame are shrinking while others are dimensionally stable, the walls of the house will rest on uneven surfaces.

If you want to use EL in key locations in the house, think in terms of systems. It would be fine, for instance, to use laminated veneer lumber (LVL) for the girder under a floor, then use sawn lumber for the floor joists. It would be a mistake, however, to use a combination of lumber and EL for either the girder or the floor joist system.

The dimensional differences are not as critical in other systems—especially those built higher in the structure. As you'll see in the next section, the use of structural composite lumber (LVL, LSL, and PSL) is acceptable for headers in sawn lumber walls. One reason this practice is acceptable is that most of the shrinkage in lumber is perpendicular to the grain of the wood; there is little shrinkage along its length.

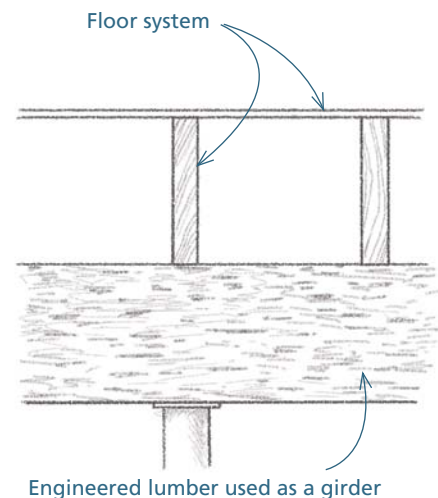
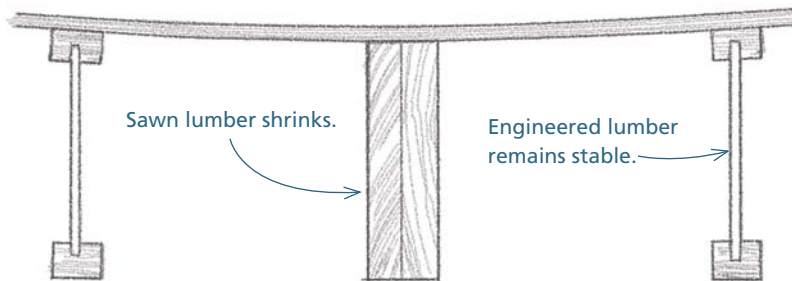

EL for Girders

Because of its dimensional stability, straightness, and great strength, structural composite lumber is an excellent material for girders. There are three types: laminated strand lumber (LSL), parallel strand lumber (PSL), and laminated veneer lumber (LVL). For most carpentry crews, LVL is the best choice because it's easiest to handle. A large beam can be built on site using two or more layers of LVL. This means no equipment is required to set it in place.

EL girders can be used with sawn lumber joists or EL joists. If you plan on using an EL girder that will be flush with the floor system, the use of EL joists is recommended because these materials are both dimensionally stable. If you use sawn lumber joists with an EL girder and you want to set the girder flush with the joists, set the tops of the joists $\frac{1}{2}$ in. higher than the top of the girder. Doing this allows for the probable shrinkage in the height of the floor joists.

Set the tops of joists $\frac{1}{2}$ in. higher than the top of the girder to allow for shrinking.

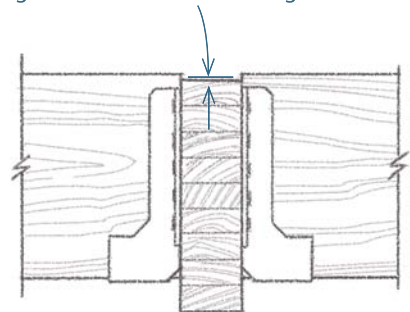

EL for Floor Joists

Wood I-joists

Wood I-joists are the most common EL material used for floor framing. They are now used almost as often as sawn lumber for joist material in new homes. Because they shrink at different rates, do not use sawn lumber with I-joists. For the rim joist on I-joist floor systems, use proprietary EL rim joist material. For large openings, such as stairwells, use structural composite lumber (LVL, PSL, or LSL). Follow the manufacturer's specifications concerning the use of metal hangers and nailing schedules

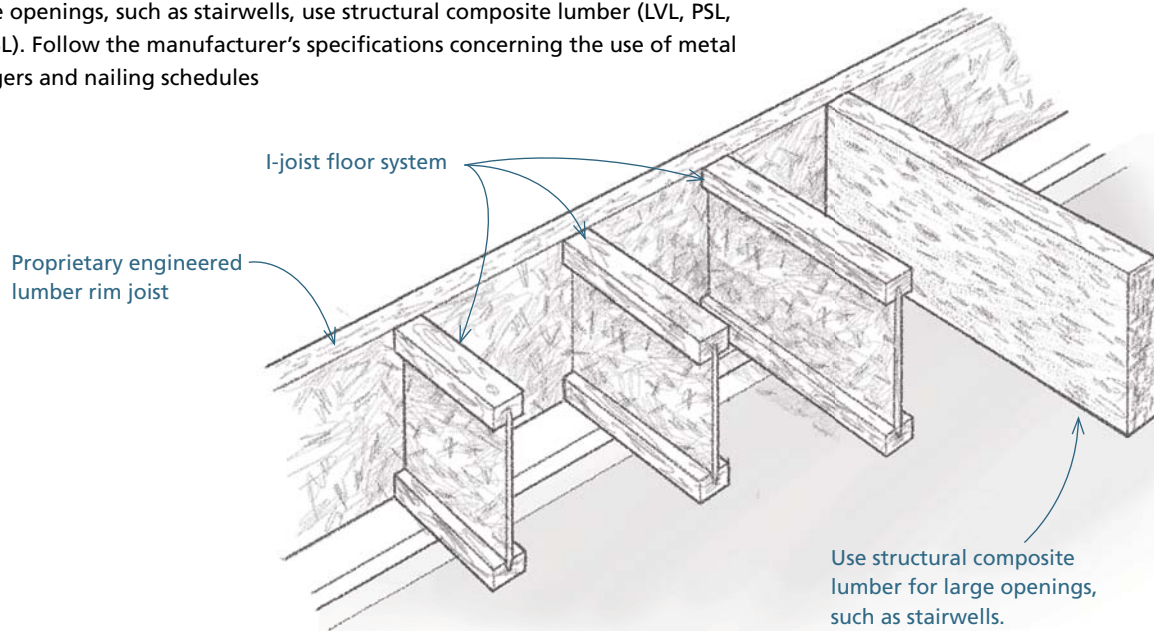

Parallel-chord floor trusses

Parallel-chord floor trusses are used in about 10% of new houses. The main advantage to using trusses instead of sawn wood or I-joists is that ducting, plumbing, and electric wires can simply be strung through the open webs. Like I-joist systems, truss systems are engineered and the manufacturer's plan must be available for inspection by code officials.

Unlike I-joists, parallel-chord trusses cannot be cut or altered in any way without the approval of a design professional. Code officials usually require a representative of the manufacturer to sign off on any changes to trusses. This means that changes are difficult to make midway through a job.

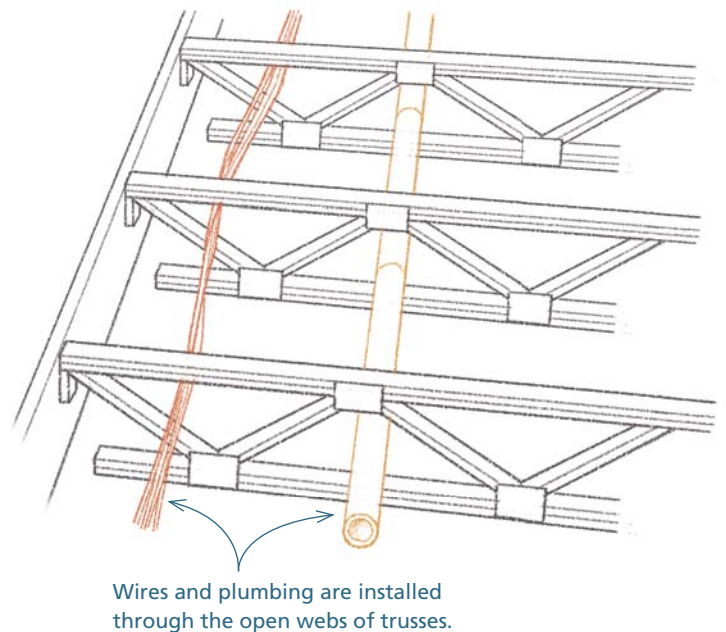

Framing Walls

When you finish the floor system, you should have a level platform on which to build and raise the walls of the house. The top surface of the floor is now fixed, and there is no practical way to adjust it. The position of the walls, however, can still be adjusted slightly. As you lay them out, you have one final opportunity to square up the house.

When you lay out and build the walls, you should continue to think ahead to the needs of the trades that will come after the completion of the frame.

The topics discussed here are roughly in the order that they would be built. However, many of the steps in this section can be completed simultaneously by different members of your crew.

Lay Out Exterior Wall Locations

Some carpenters lay out the locations for all the walls of the house at this stage. An alternative method is to lay out, build, and erect the exterior walls first, then lay out the interior walls. This second sequence is the one that will be followed here.

STEP 1 Check the floor system for square

Use the techniques described in the section on installing mudsills on p. 54.

1 Measure the length, width, and diagonals of the floor to see if it's the right size and square.

2 Make final adjustments to get exterior walls square and parallel.

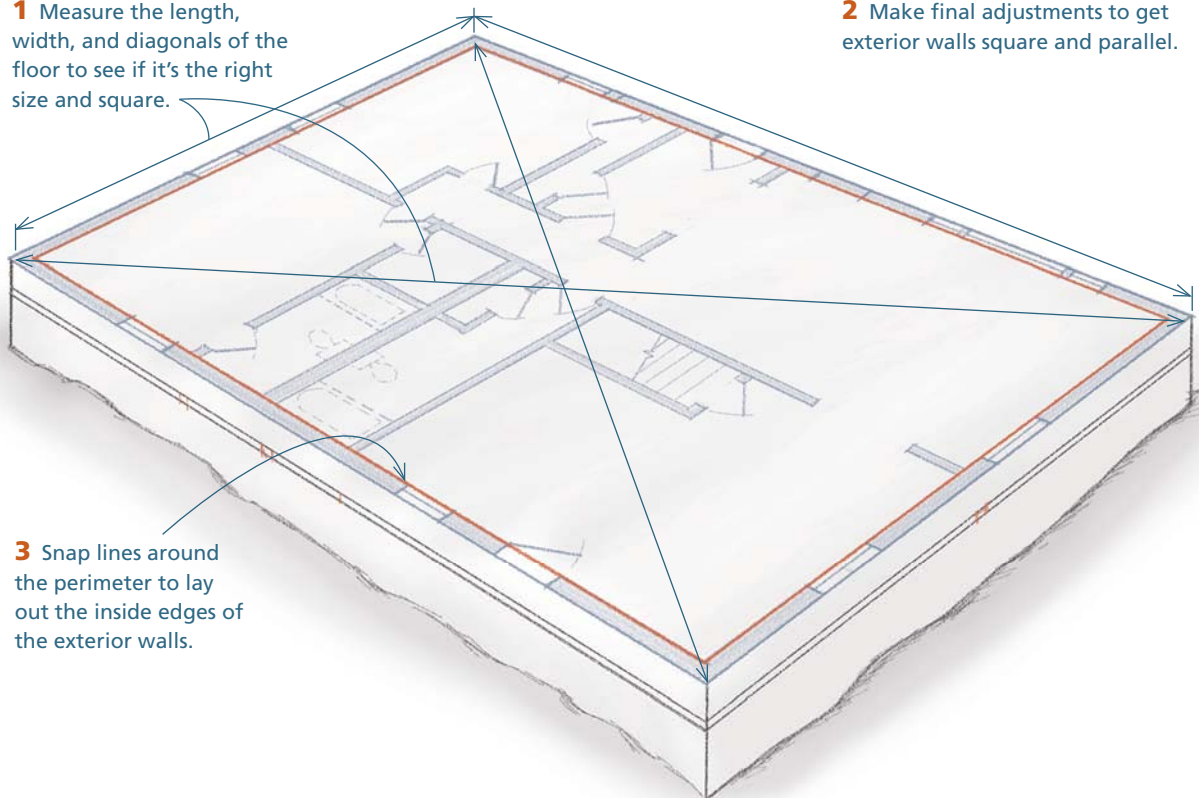

3 Snap lines around the perimeter to lay out the inside edges of the exterior walls.

STEP 2 Lay out the locations of intersecting walls

After laying out the locations of the exterior walls, examine the plan and note the exact locations of intersecting walls. Lay out the locations of any intersecting walls that are not already laid out on the mudsills. Compare these locations with the wall locations marked on the sides of the mudsill and make sure they're the same.

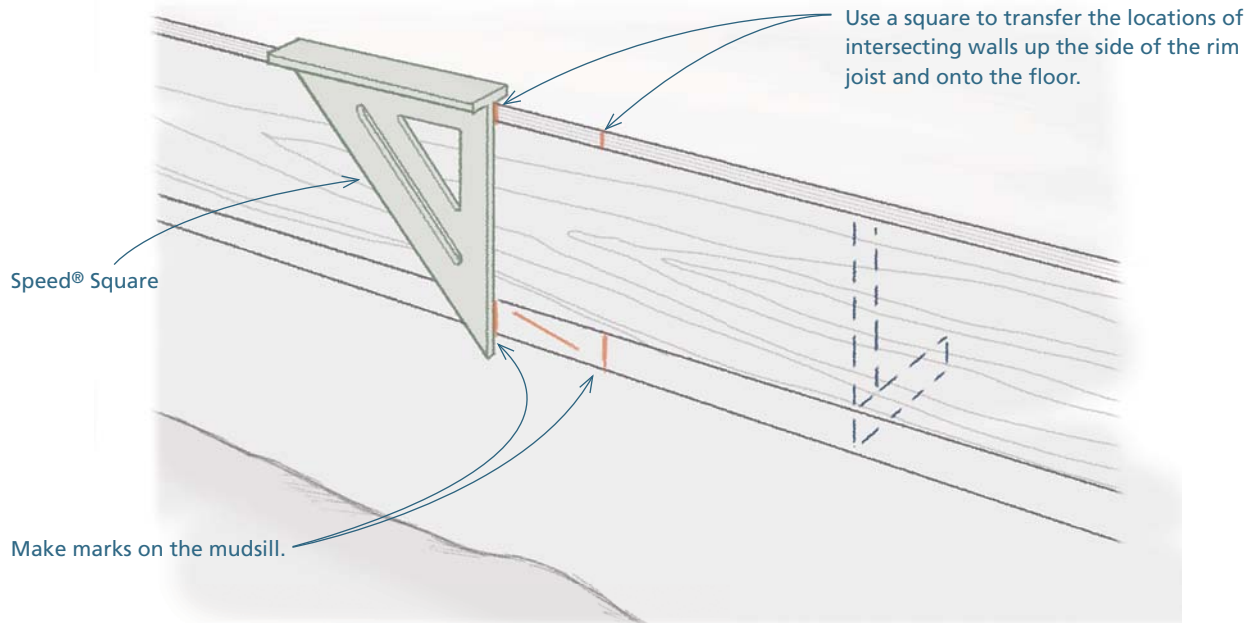

TOP TIP

Split the Difference

Dealing with uneven, out-of-square, and out-of-level structures and surfaces is a fact of life. Fortunately, each new stage of the job provides an opportunity to remove these imperfections. When you spot a problem, however, don't feel compelled to remove the problem in one fell swoop. In some cases, doing this makes the flaw more obvious. In these cases, it's often better to split the difference between the ideal and the existing.

Building codes require 2x6 walls where 3-in. drains or vents will be used.

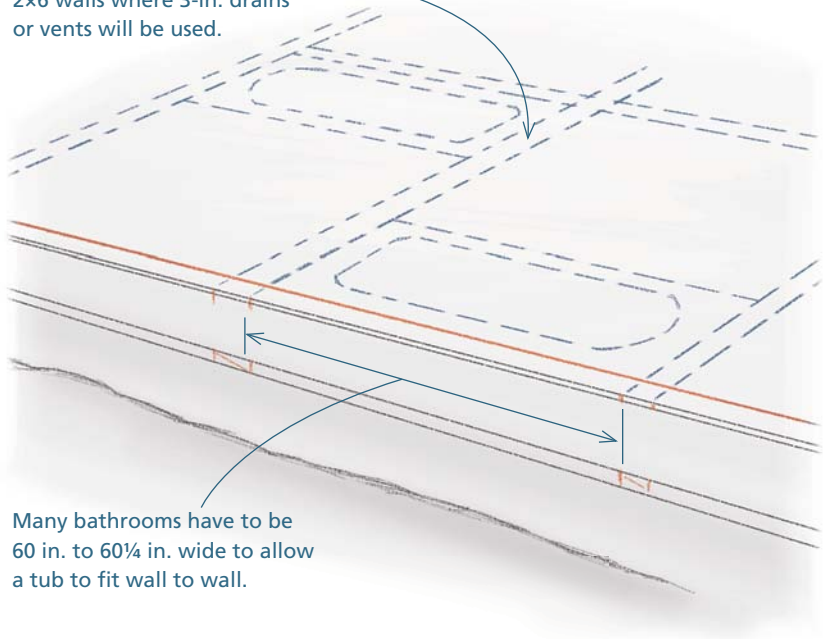

Lay Out Details on Exterior Wall Plates

STEP 1 Sort and crown lumber for the plates

1 Set aside the straightest pieces of lumber for the plates.

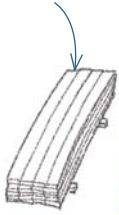

2 Place a single line of plates carefully along layout lines, and transfer intersecting wall locations onto the plates.

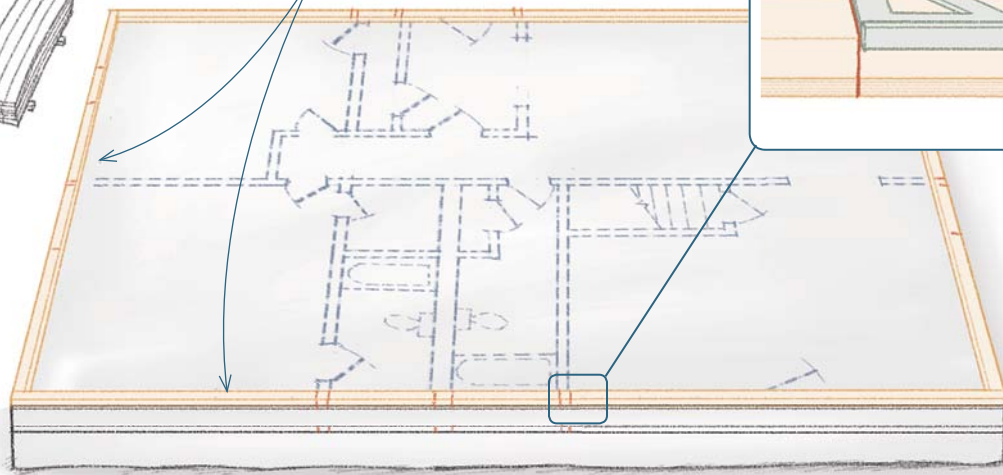

3 Use a square to scribe perpendicular lines across the plates.

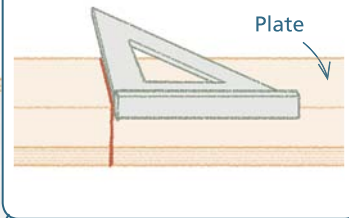

WAYS OF WORKING

Eye the Center, then Measure Out

In some instances, the designer indicates that the window or door should be centered in a given space. When this is the case, you can quickly find the center without using math. The basic premise of this procedure is that the center of a space is the same distance from each side of the space.

1 Mark, by eye, what you think is the center.

2 Measure the distance from one side of the space to the mark.

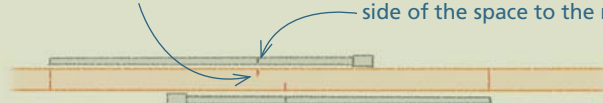

3 Measure and mark the same distance from the other side.

4 Without removing the tape, mark, by eye, what appears to be the center between the marks.

5 Measure the same amount from the other side and mark.

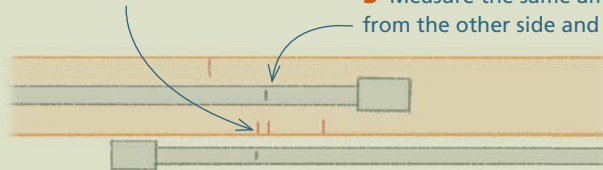

6 The two marks should now be close together and you should be able to mark the center by eye.



7 You can double-check by measuring from both sides to confirm that the final mark is exactly the same distance from both walls.

STEP 2 Mark the locations of the rough openings

Lay out the locations for the exterior doors and windows. Typically, these are indicated on the drawing by a dimension that extends from an intersecting wall (which should already be marked on the plate) to the center of the opening. When you measure and mark this point, make sure you measure from the side of the wall indicated on the drawing.

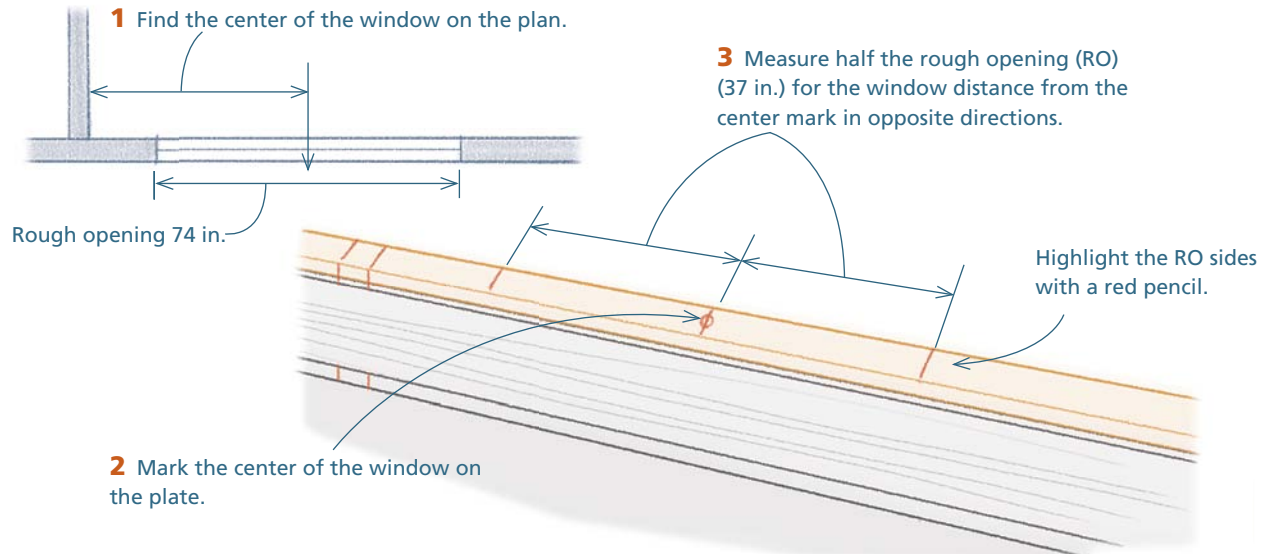

STEP 3 Lay out the trimmer and king studs

A modular, 16-in. o.c. pattern should be maintained under windows and above headers. To differentiate these studs, called cripple studs, from full-length studs, write C instead of X after the mark. Lay out the trimmer studs on both sides of the opening. Make sure you mark the trimmers outside of the marks for the openings. The trimmers will go under the headers and support their weight. Mark trimmers with Ts.

Measure and mark $15\frac{1}{4}$ in. from the end of the plate, and draw an X ahead of the mark to indicate that the layout is "set ahead."

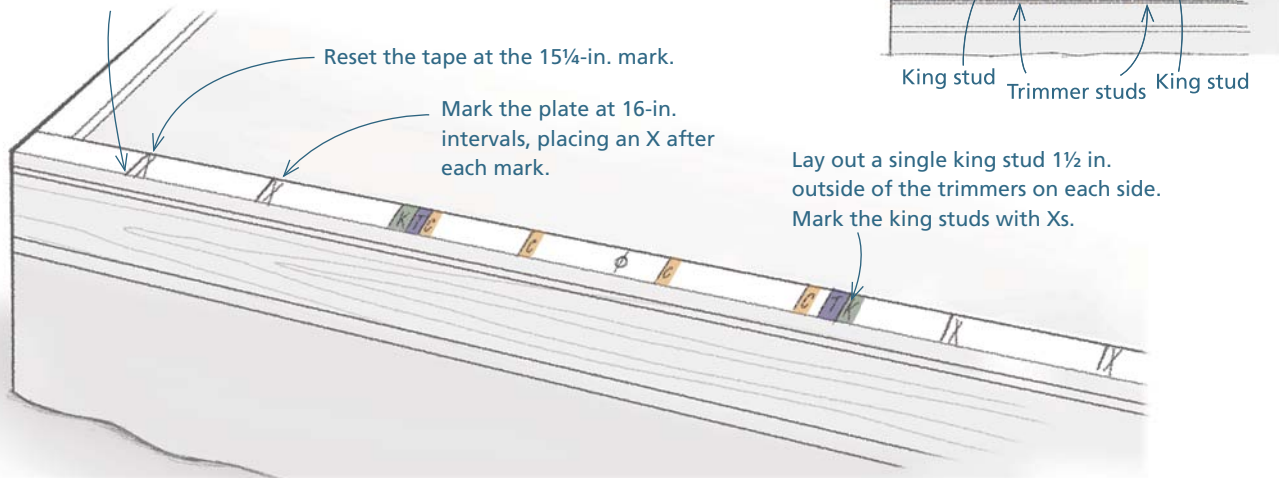

ESSENTIAL SKILLS

Rough Openings for Doors and Windows

The first step in determining the size of a rough opening is to find out exactly what window or door will be used. You need to know the manufacturer, kind of door or window, model number, and size. Once you know this information, look in the manufacturer's literature for the rough opening (RO) needed. Catalogs are often available through the supplier or they can be ordered or downloaded. The first dimension is usually the width and the second dimension is the height.

• EXTERIOR DOORS

It is up to the carpenter in the field to calculate the size of the rough opening needed.

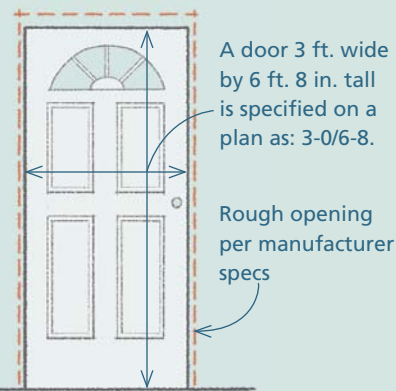

Steel and fiberglass exterior doors are often 1 in. shorter than their nominal size. You can use the nominal height to calculate the RO.

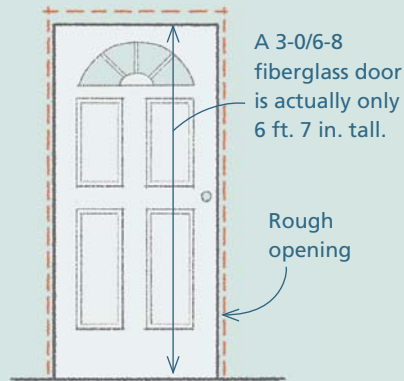

• INTERIOR DOORS

The rough opening for a basic hinged interior door is usually 2 in. wider and 2¼ in. taller than the nominal size of the door.

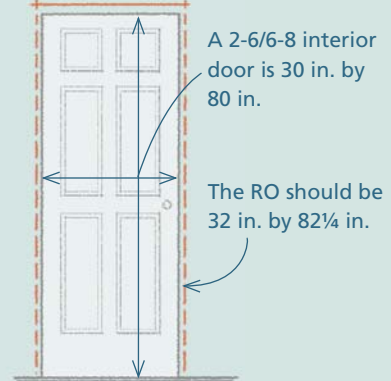

If pocket doors, bifold doors, bypass doors, or interior double doors are planned, find out what the required RO is for that specific unit.

• ROUGH OPENINGS FOR WINDOWS

ROs for windows are not standardized. Some designers note them, usually in foot-inch form, on the drawing. Others attach a window schedule with ROs on a separate sheet of the plans. In some cases, the windows are specified, but it's left up to the builder to look up the required RO for them. For their part, some window manufacturers provide ROs in foot-inch designations; others use straight inches.

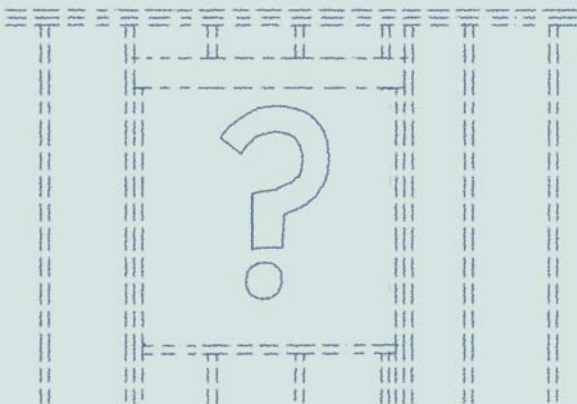

• USE STRAIGHT INCHES

It's easy to look at a plan and see 6-2 designated and think "sixty-two inches." In reality, the 6-2 designation is 6 ft. 2 in., or 74 in. This can be confusing, especially when it comes to window openings. One way to avoid this confusion is to go through the plan and change the foot-inch designations for ROs to straight inches. An added benefit is that it's usually easier to divide an inches-only dimension in half (which is a necessary step when laying out an opening from a center point).

Fabricate the Components of the Exterior Walls

If you have a crew, some members can occupy themselves with fabricating the components of the wall while others are laying out the details on the plates. The components serve different functions. Some, such as headers, are primarily structural. Others, such as corners and T-intersections, are designed mainly to provide solid nailing surfaces for subsequent tradesmen.

Corners

Fabricated corners serve a few functions. They tie the perpendicular walls together. They provide solid nailing surfaces for drywall and trim inside the house. And they provide solid nailing surfaces for siding and corners outside the house.

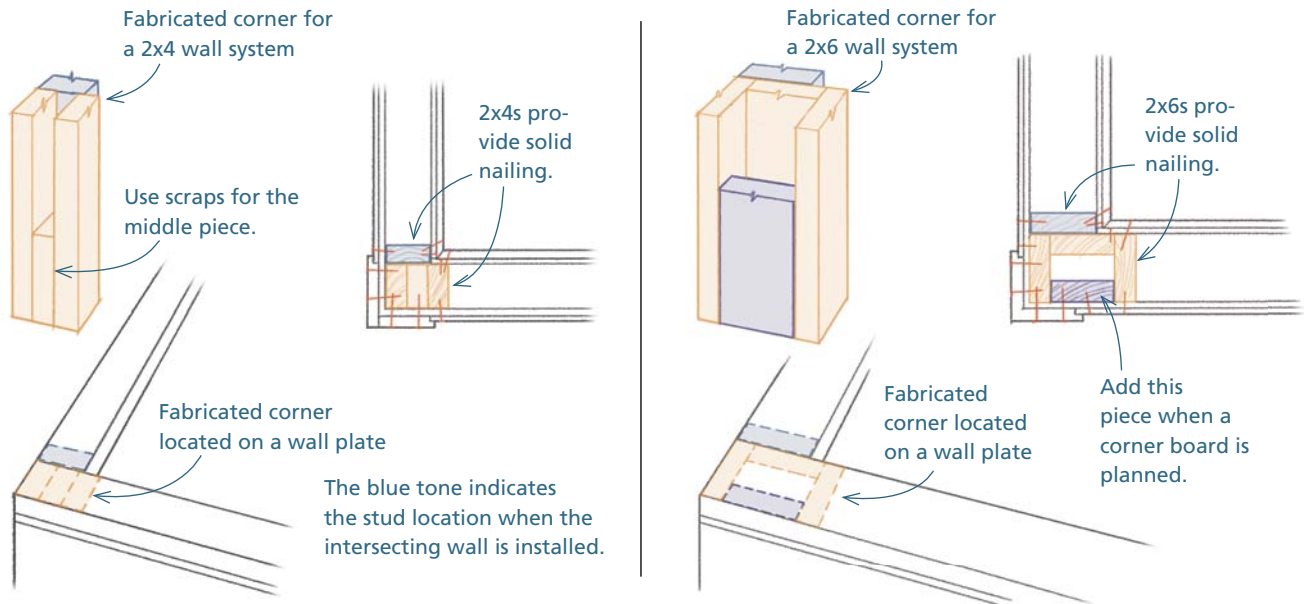

T-intersections

T-intersections tie intersecting walls together and provide solid nailing surfaces for drywall in the inside corners of rooms.

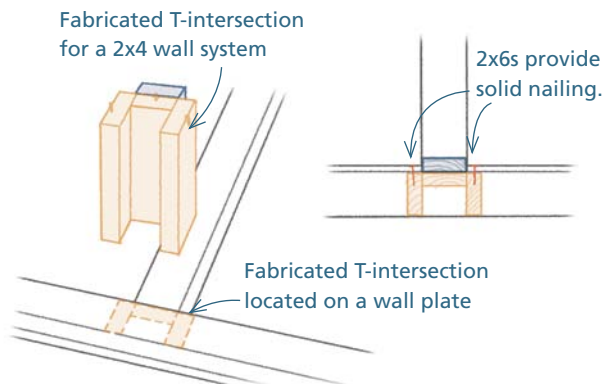

Bearing headers

Bearing headers are structural beams that span openings and carry the weight of overhead floors, ceilings, and roof systems. Engineered lumber is sometimes used for headers because of its strength, stability, and straightness. Built-up headers fabricated from sawn lumber are more common for openings less than 8 ft. wide. These built-up headers are less expensive than EL and they can be insulated. Because they're structural, bearing headers must meet the requirements of the code. Their size, which is based on the dead and live loads they carry, is usually specified in the plan.

• HEADERS IN 2×4 WALLS

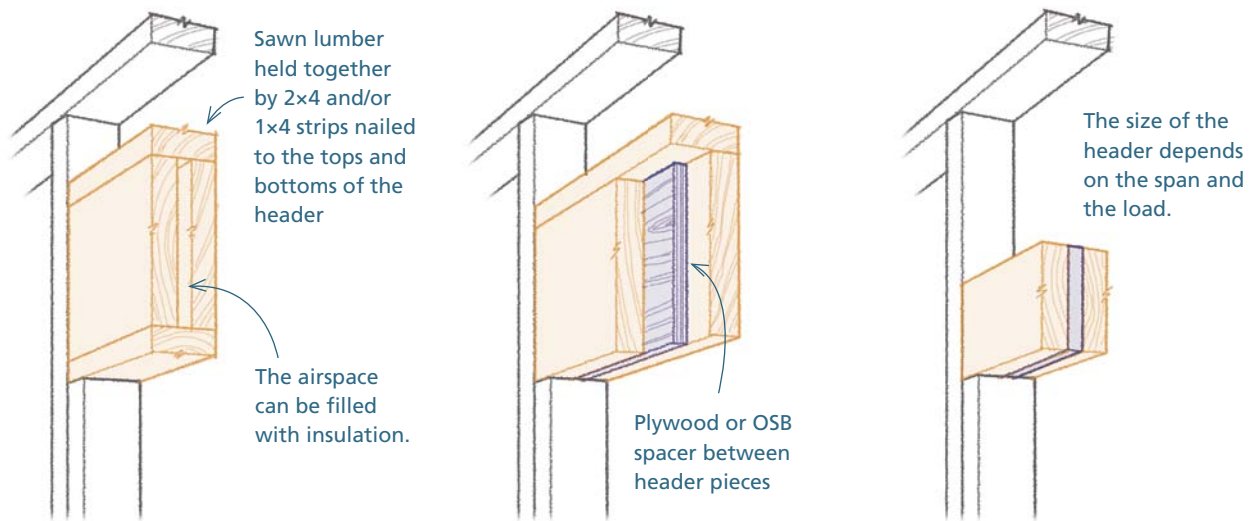

• HEADERS IN 2×6 WALLS

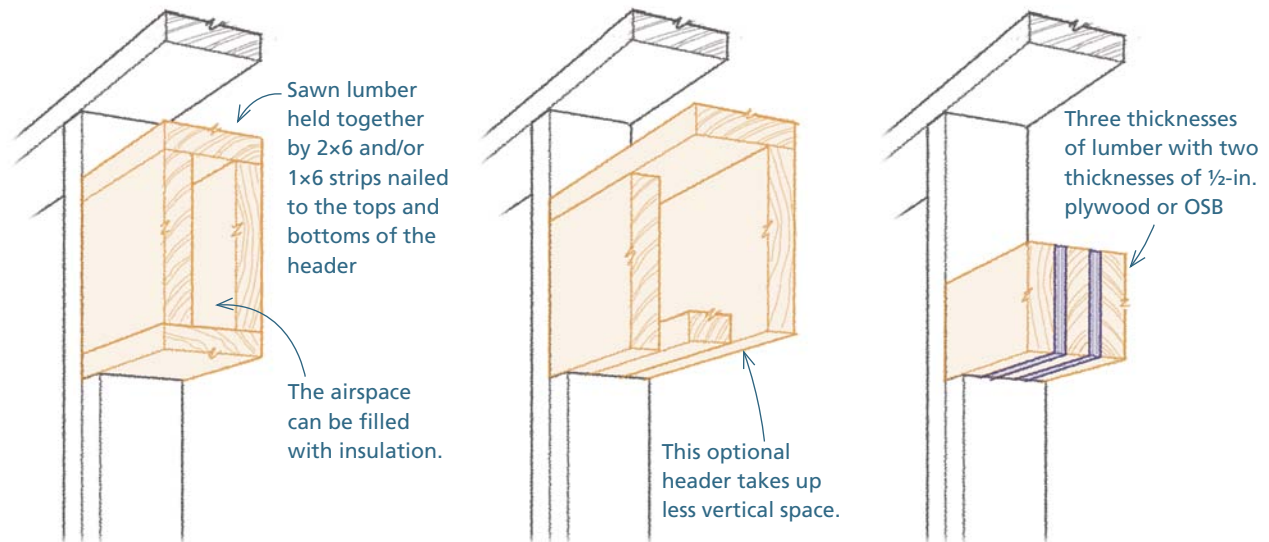

Nonbearing headers

Headers that span openings on walls that run parallel to floor and ceiling joists and rafters often carry little weight. For narrow openings, these can often be made with the same material used to build the walls (2x4s or 2x6s).

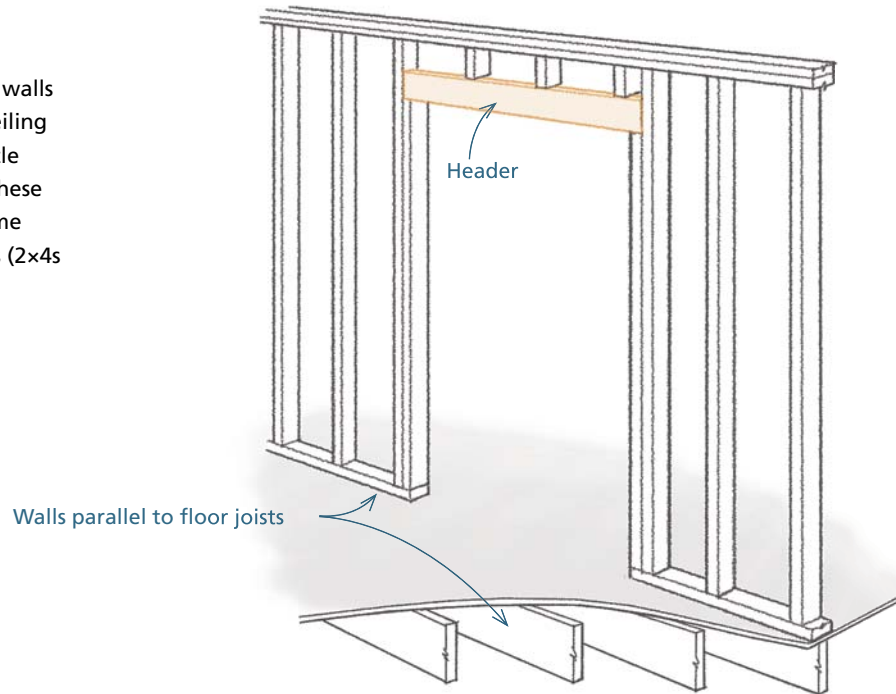

Measuring the lengths of headers

The lengths of headers can be measured off the plates you've just laid out. If there are single trimmers, the header will be 3 in. larger than the RO; if there are double trimmers, the header will be 6 in. larger than the RO.

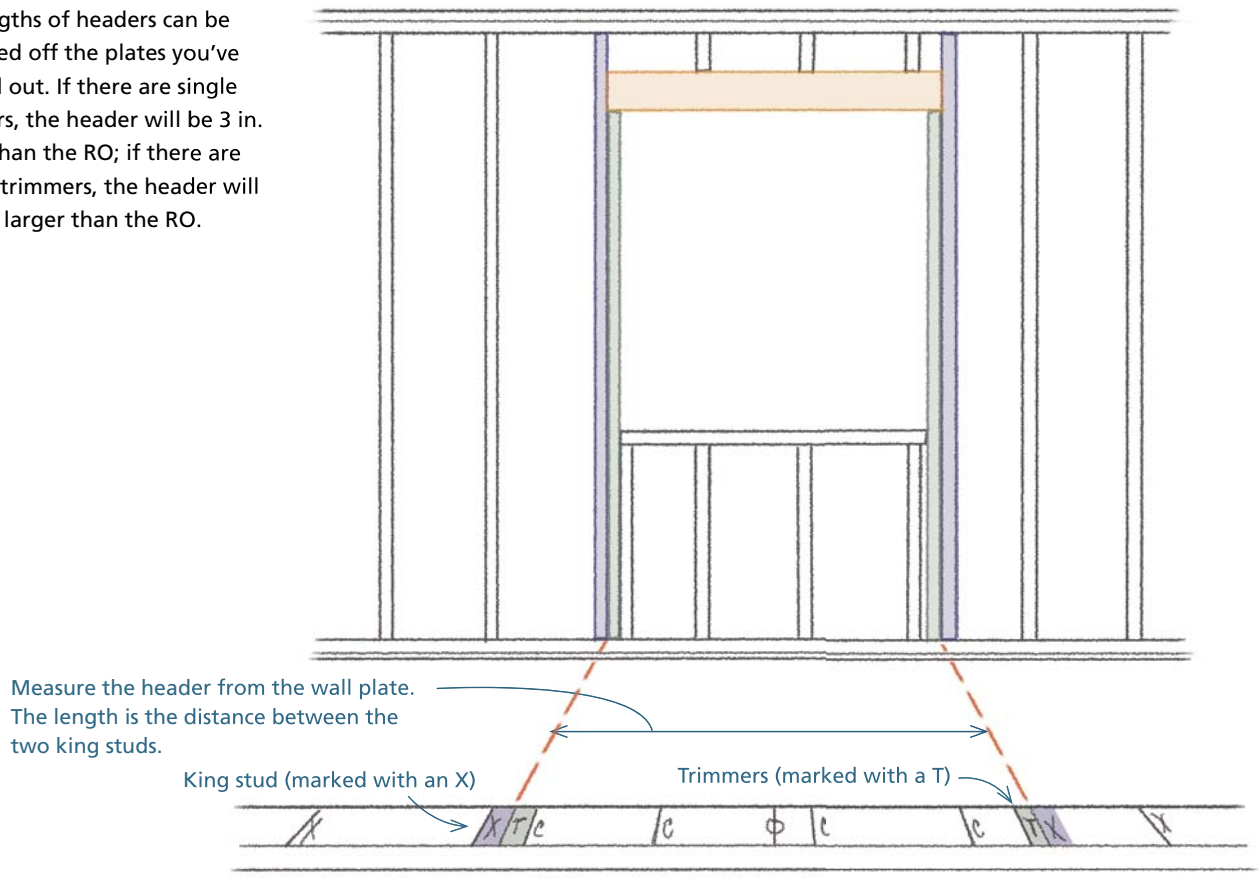

Trimmers and bearing headers for entry doors

Trimmer studs support headers. They are usually set on the bottom plate. The length of trimmers varies with the height of the RO. Carpenters sometimes adjust the height of ROs to fit the size of headers. It's usually safe to make the height of ROs for doors slightly larger than those called for by manufacturers.

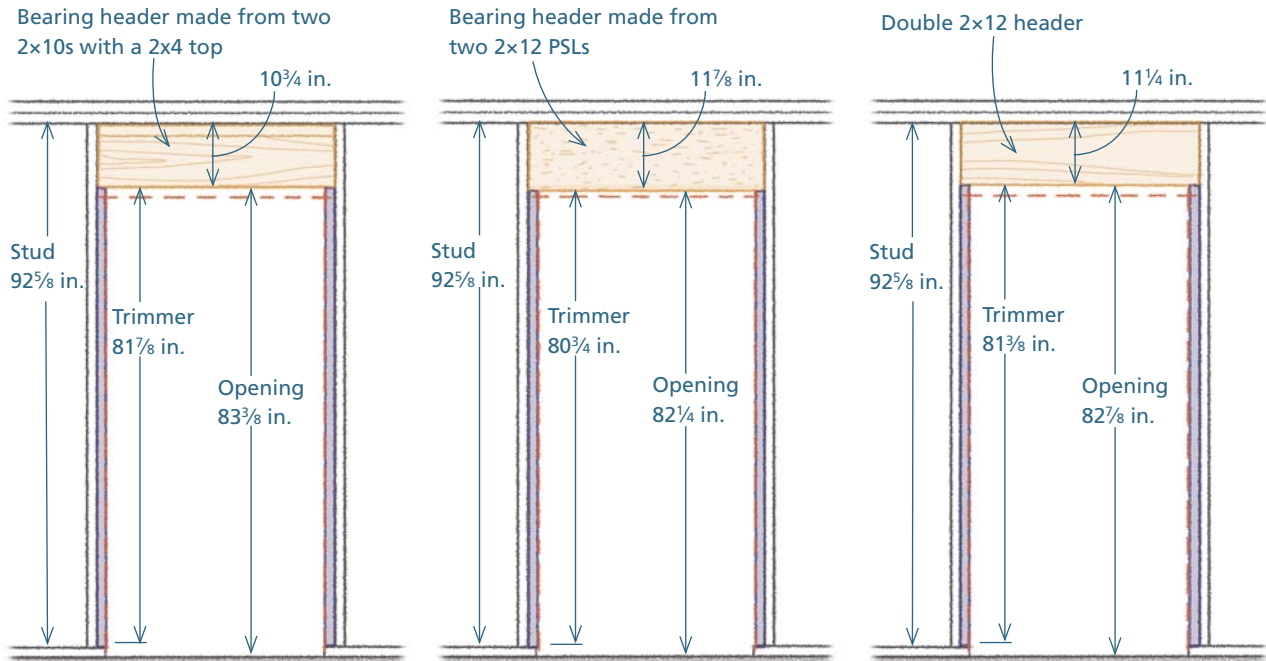

(If 92 1/4-in. or 93-in. studs are standard, the trimmer size would have to be 81 1/2 in. or 82 1/4 in., respectively.)

• WINDOWS AND INTERIOR DOORS

2x10s with a 2x4 on top and a 1x4 on bottom

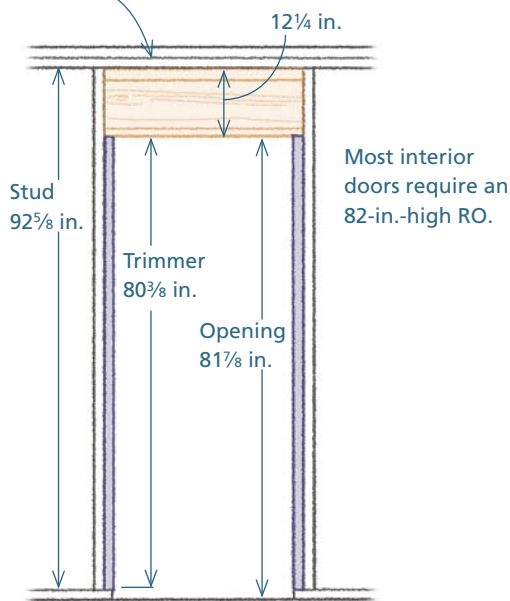

• TRIMMERS AND NONBEARING HEADERS

Headers in nonbearing walls carry little weight and usually need only be stiff enough to keep from sagging.

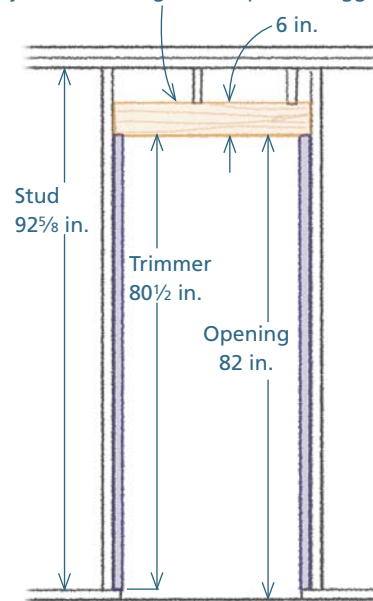

Cripple studs and windowsills

Cripple studs extend from the bottom of windowsills to the top of the bottom plate or from the top of the header to the bottom of the lower top plate. Although high-productivity crews often cut all the cripples and sills at once, it's simpler to measure and cut these after you install the trimmers and headers.

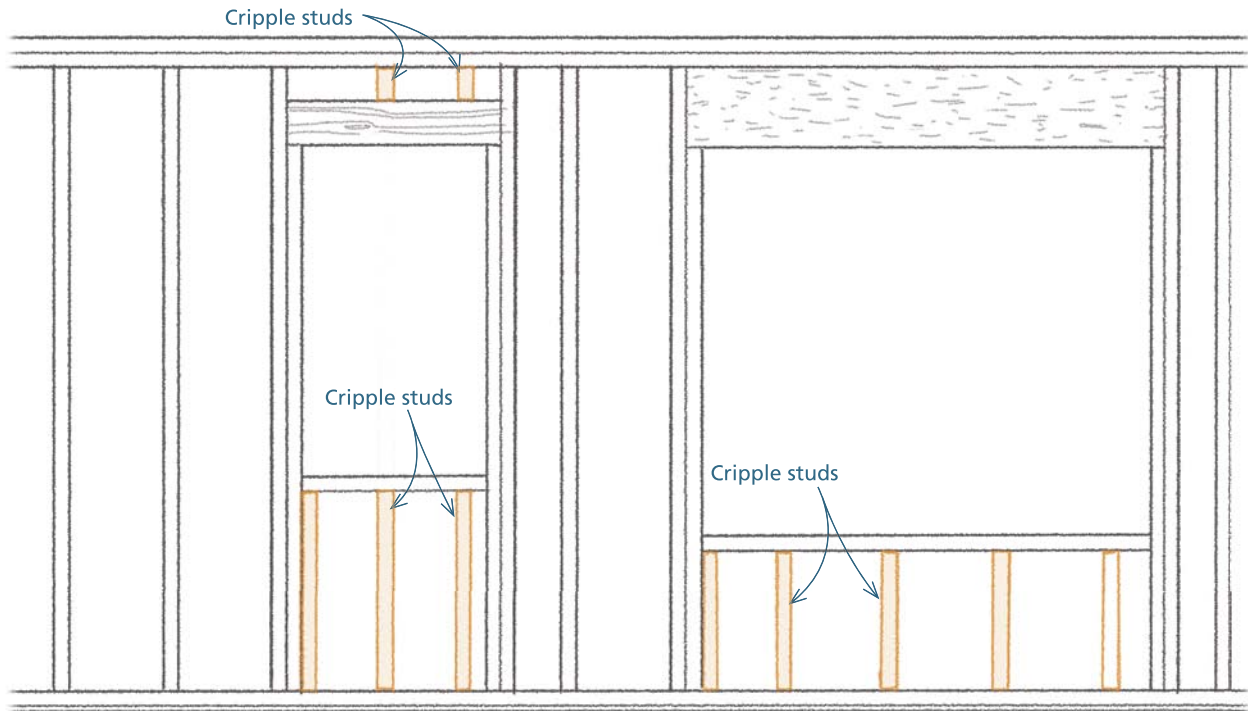

A Word about Header Height

To optimize a sense of order, the tops of windows and interior doors should be the same height. To do this, try to keep the bottom-of-header height consistent throughout the house for windows and interior doors. This not only looks better but also simplifies the job and saves time. Once you select a header height, make all the trimmers the same size.

Keeping the tops of openings the same height is not always possible or desirable. Exterior doors, unusual or custom doors, and very large openings sometimes require different bottom-of-header heights. In some cases, designers deliberately lower the tops of windows for aesthetic reasons.

The height of bearing headers does not always have to fill the space from the top of the RO to the underside of the top plate. For narrow openings, you can often use smaller pieces of lumber to satisfy structural requirements. When using smaller pieces for headers, you have to use cripple studs above the header. If, for example, you use 2x6s for a door opening, you have to use short cripple studs above the opening to help carry the load. Using smaller pieces for the header saves lumber but requires more labor. The cripple studs are often very short and prone to splitting. Carpenters and builders differ on the relative merits of these two systems.

Building Exterior Walls

There are many ways to assemble exterior walls. Although carpenters sometimes argue fiercely over which is the “correct” way to build the wall, the exact sequence has little effect on the quality of the finished wall. The following is a fairly common order of assembly.

STEP 1 Lay out the top plate

After you’ve laid out the locations of the corners, T-intersections, and studs on the bottom plate (or plates, if you’re building a long wall), you need to transfer the layout to the top plate. The object is to execute a layout that precisely mirrors the one on the bottom plate.

1 Align the plates side by side.

2 Clamps keep the plates from moving and remove bows that might affect accuracy.

3 Use a square to extend lines from the marked plate to the unmarked plate.

4 Transfer Xs, Ts, and Cs, keeping symbols on the same side of the line as on the first plate.

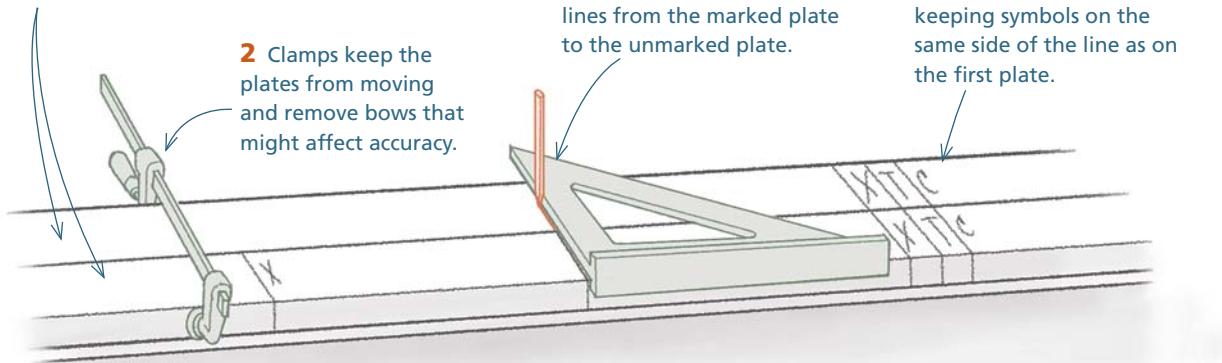

STEP 2 Install the studs, corners, and T-intersections

Set the crown of all the studs in the same direction.

3 Hold the stud to the layout line, and nail through the plate into the top of the stud, corner, or other vertical piece.

2 Place the corners, T-intersections, studs, and headers in their proper places between the plates.

1 Move the plates about 9 ft. apart.

Use two 12d nails.

Place the connecting blocks of the T-intersections down to face inside once the walls are lifted.

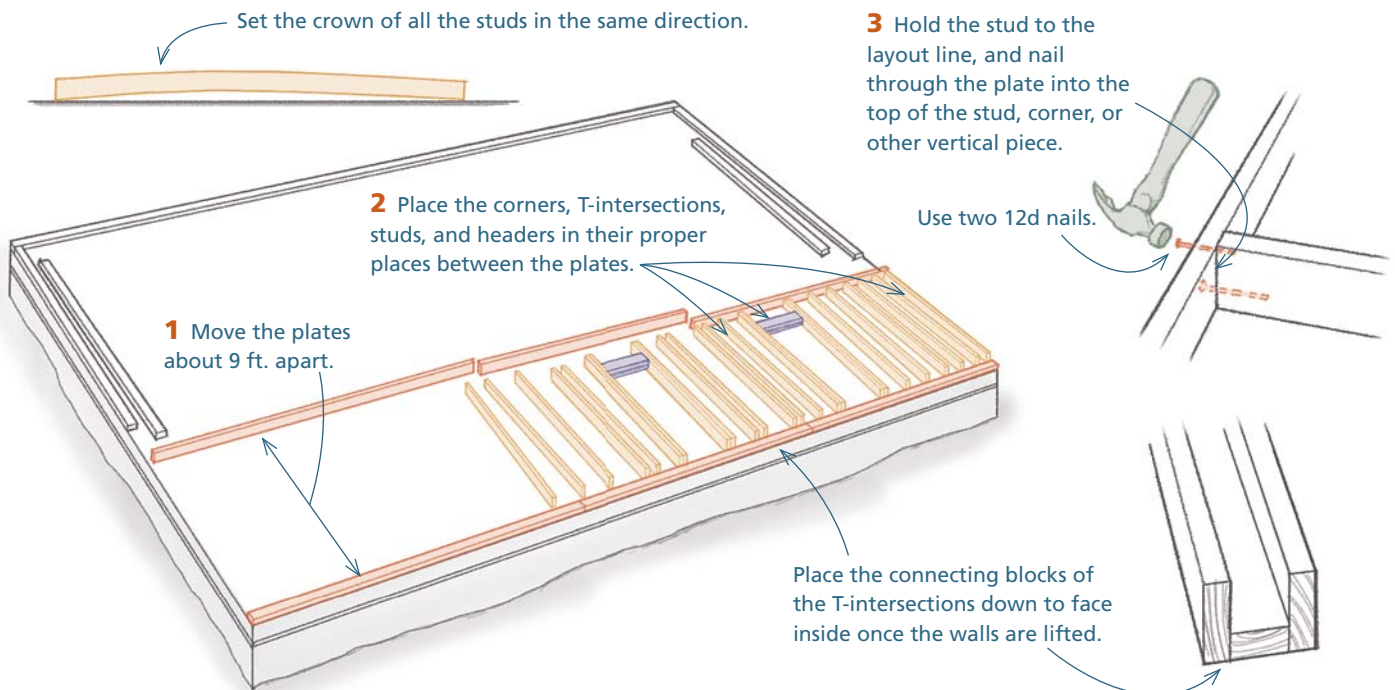

STEP 3 Build the openings

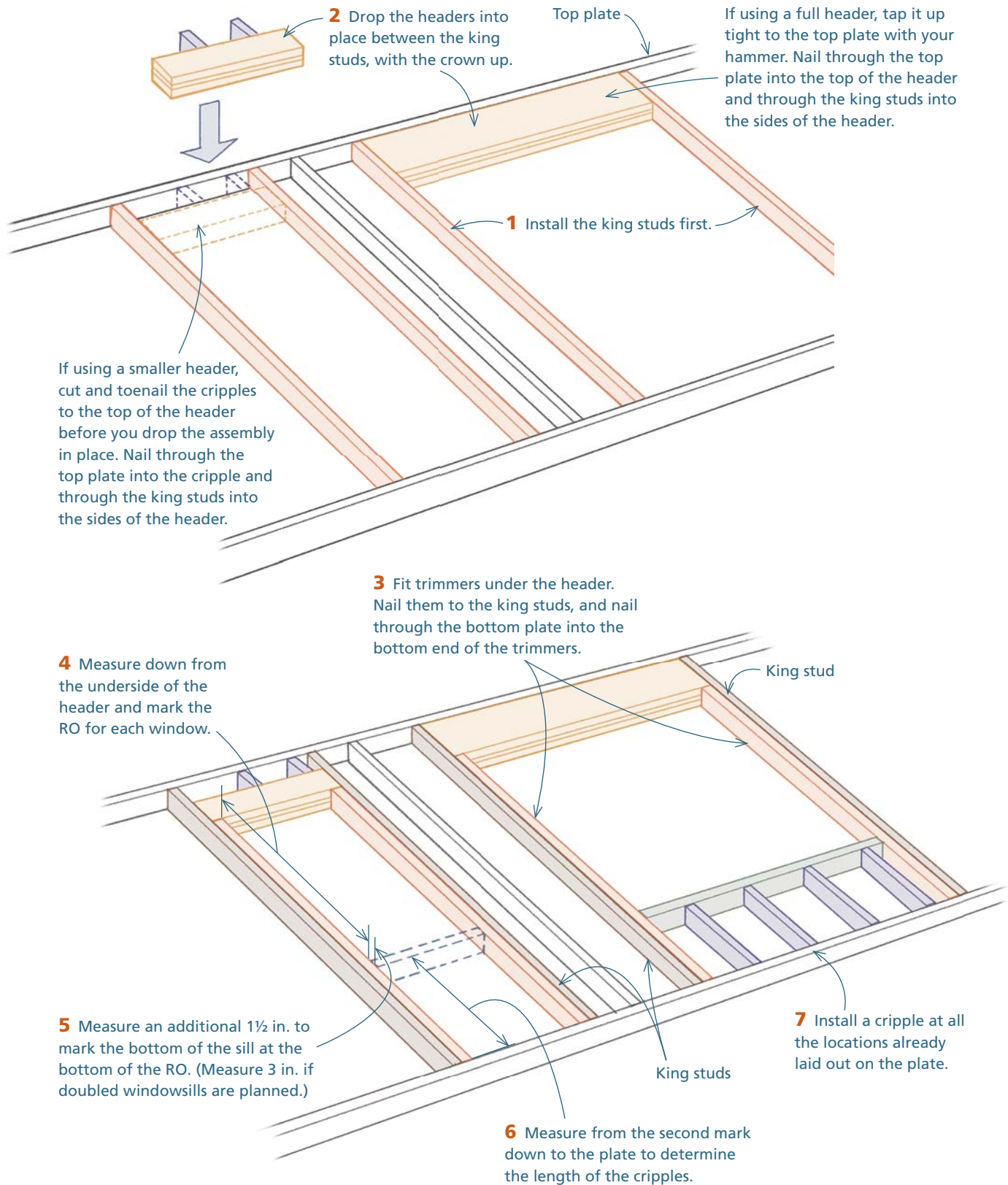

Sheathe the Wall

Sheathing the walls helps to protect the interior of the house from the weather. Sheathing systems also serve two structural functions. First, they hold the wall rigidly square; second, they tie the parts of the wall together and, in many cases, tie the wall to the floor system. The nails used to attach sheathing are important in any sheathing system. It's important, therefore, to know and follow the nailing schedule as required by the code or specified in the plan.

Exterior walls can be sheathed before or after they are raised. In this example, the walls will be sheathed prior to being raised.

STEP 1 Anchor the wall and adjust for square

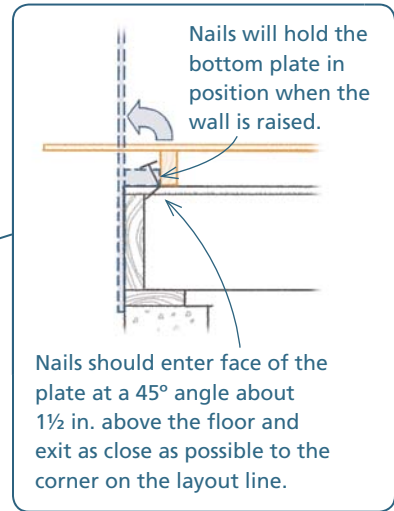
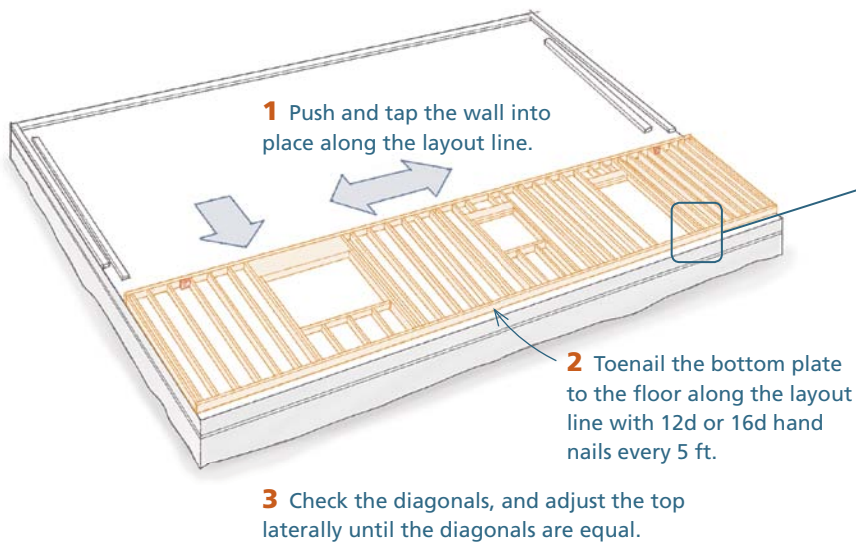

STEP 2 Nail on the sheathing

- 1** Measure and mark the thickness of the floor up from the bottom of sheathing on each side and align marks with bottom of wall.
- 2** Nail the sheet according to specified nailing schedule.

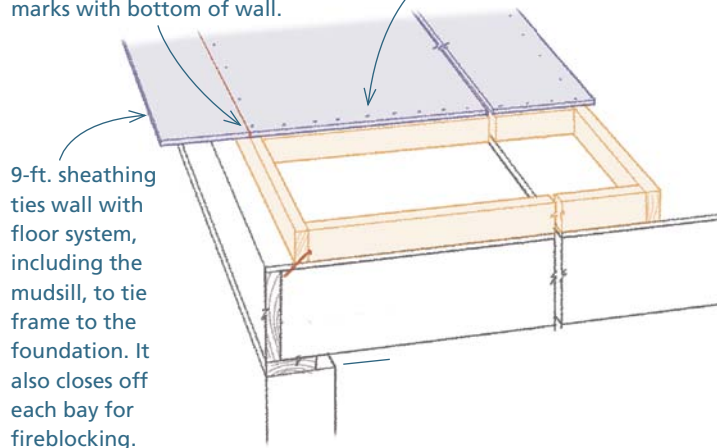

TOP TIP

Wall Openings

Where you encounter openings, you can measure, mark, and cut the panels before you install them. Alternatively, you can nail the panels on whole and cut the openings at any time afterwards. Some carpentry crews wait until the walls are built and installed before they cut the sheathing at the openings.

TOP TIP

Raising Walls

Sheathed walls are not just heavy and unwieldy; they also present a broad target to the wind. A wall that gets away from a crew can topple off the edge of the floor. Worse, it can fall on a crew member. Make sure you have a big enough crew to raise the wall, hold it upright, and brace it off quickly.

If it's windy, consider postponing the wall raising until the wind dies down. If you can't wait for a milder day, build and raise the wall in manageable sections or build and raise it without sheathing. The sheathing can be installed later on the standing frame.

Raise and Brace the Exterior Walls

Sheathed walls are heavy and unwieldy, so it's important to have an adequate crew for the raising.

STEP 1 Plan the wall raising

Discuss the sequence of the raising and bracing before you lift the wall. You'll need at least one person to install the braces as the rest of the crew holds the wall in a vertical position. Ideally, you'll have an extra person for that job. If you don't, select a person to leave the wall and install the braces after it's up.

Use a flat bar to lever up the top plate of the wall in several places.

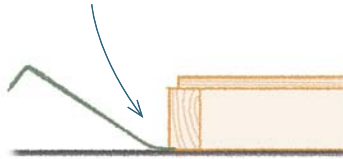

Place 2x4 blocks under the edge. The gap between the wall and floor will allow crew members to get a good grip.

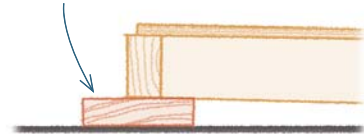

To lift the wall, position one person for every 8 to 10 ft. of a sheathed 2x4 wall and one person for every 6 to 8 ft. of a 2x6 wall.

A sledgehammer and a stepladder or stool are needed after the wall is raised.

Have several pieces of 2x4x12-ft. lumber on hand for braces. Also, have 2x4 scraps to attach as blocks to the floor and braces.

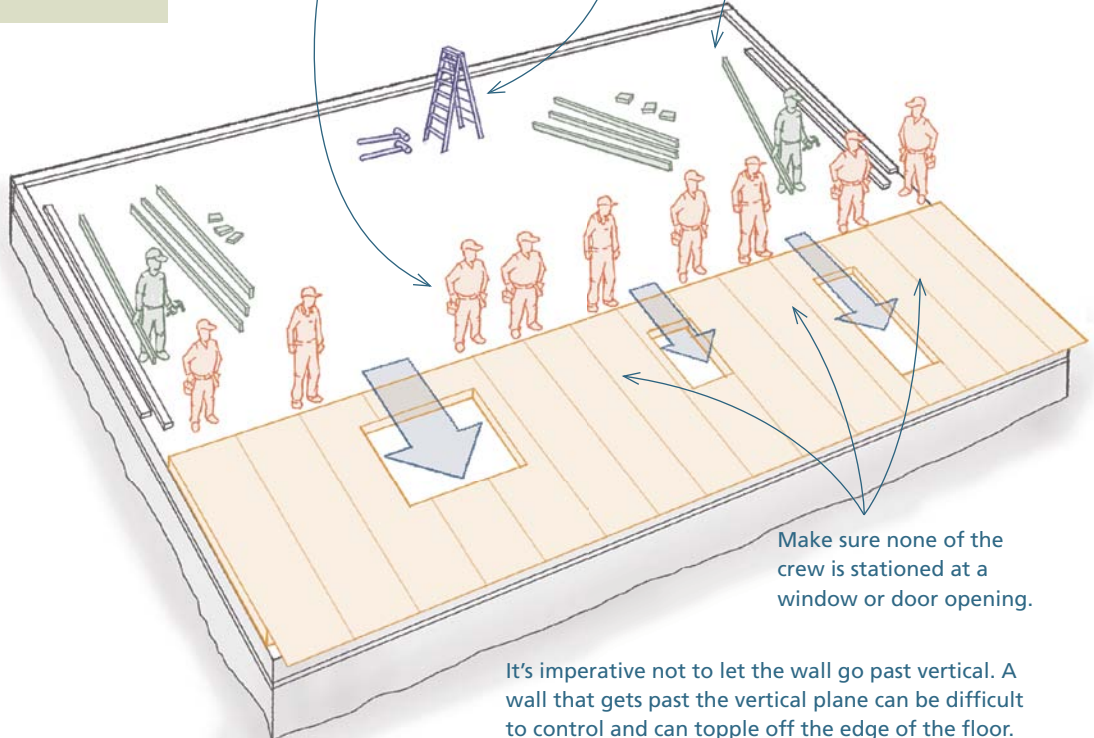

Make sure none of the crew is stationed at a window or door opening.

It's imperative not to let the wall go past vertical. A wall that gets past the vertical plane can be difficult to control and can topple off the edge of the floor.

STEP 2 Raise and secure the wall

1 Slowly lift the wall, pushing up and moving one hand over the other as you walk forward.

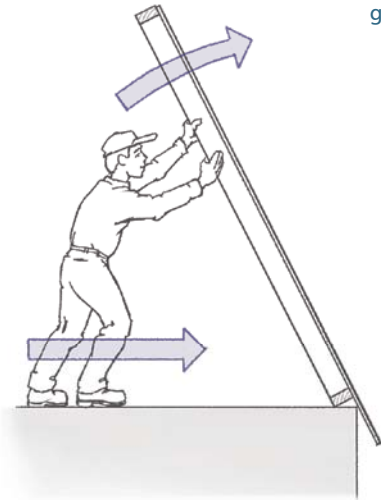

2 As the wall gets close to vertical, grab the studs to keep the wall from going too far.



3 With the wall upright, check that it is on the layout line.

4 Adjust the wall into position with a sledgehammer.

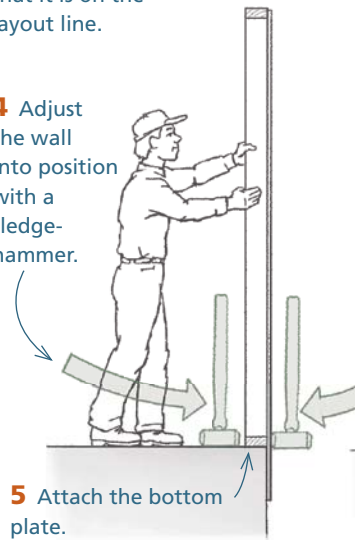

6 Nail braces to the top of the wall and to scraps of wood on the deck.

7 Nail or screw the scraps of 2x4 to the floor.

8 Place the braces every 10 ft. or so along the wall.

STEP 3 Plumb, straighten, and rebrace the wall

The wall is now held rigidly square with the sheathing and it's nailed securely along the layout line. If it weren't for the temporary braces, the whole system could pivot like a gigantic hinge. The next step is to brace the face of the wall plumb and make sure that it's straight down its length.

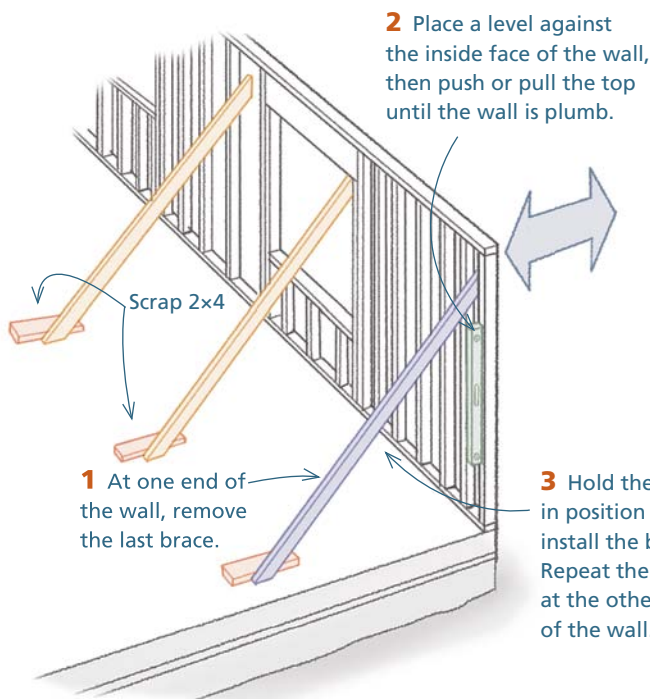

2 Place a level against the inside face of the wall, then push or pull the top until the wall is plumb.

1 At one end of the wall, remove the last brace.

3 Hold the wall in position and install the brace. Repeat the process at the other end of the wall.

6 Slide a scrap of 2x4 gauge between the face of the wall and the string as a guide to straighten and plumb the rest of the wall.

5 Remove the temporary braces one at a time. Follow step 6, then reinstall.

4 Nail a block of 2x4 at the top inside edge of each corner, and extend a string line from block to block along the length of the wall.

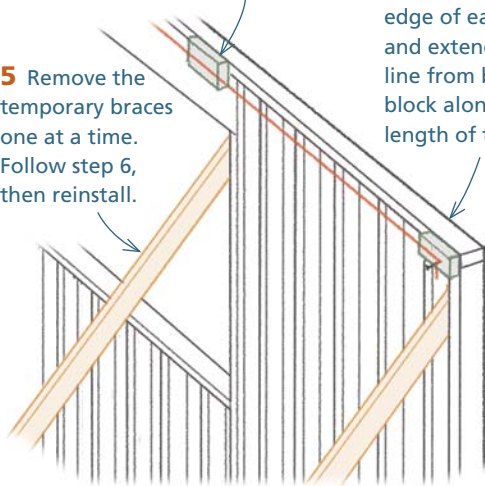

If the bottom plate is nailed along a straight line and the two corners are plumb, the rest of the wall will be plumb if the top follows a straight line.

Details to Remember

When laying out interior walls, there are a few things to think about during the layout. The first is the plumbing. Because of concerns over freezing and the need for access for future repairs, plumbing supply lines are usually placed in interior walls.

Another area of concern is the distance between door openings and the inside corners of walls. Although this is rarely indicated in drawings, you usually need at least 3 in. between the opening and the corner.

Third, setting the bottom of the headers the same height throughout the house can save time and make the finished rooms look more orderly.

• PLUMBING

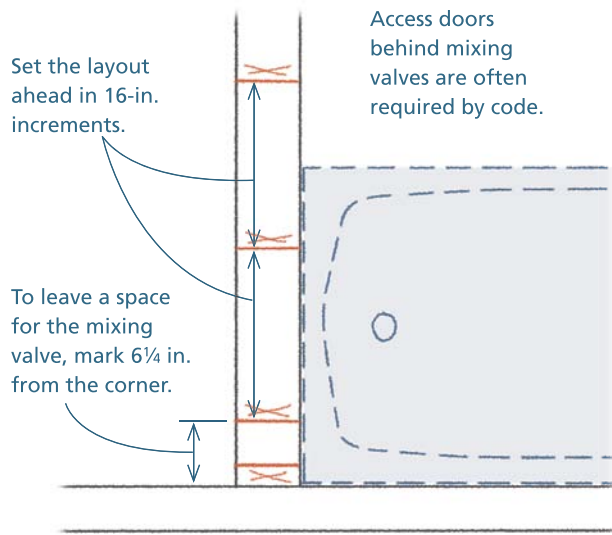

• DOOR CASING AT INSIDE CORNERS

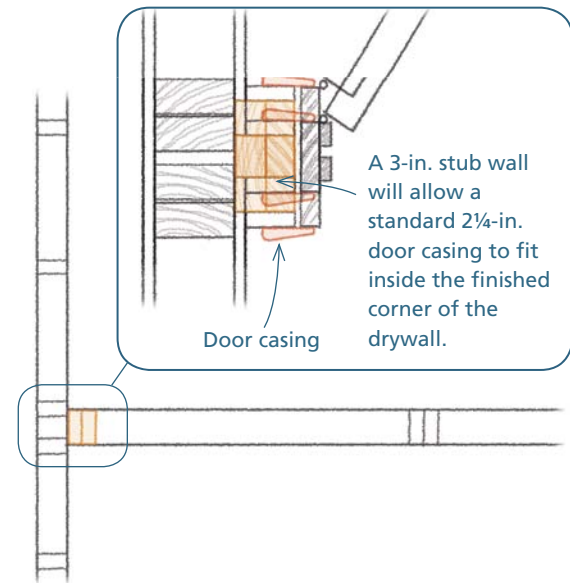

• HEADER HEIGHT

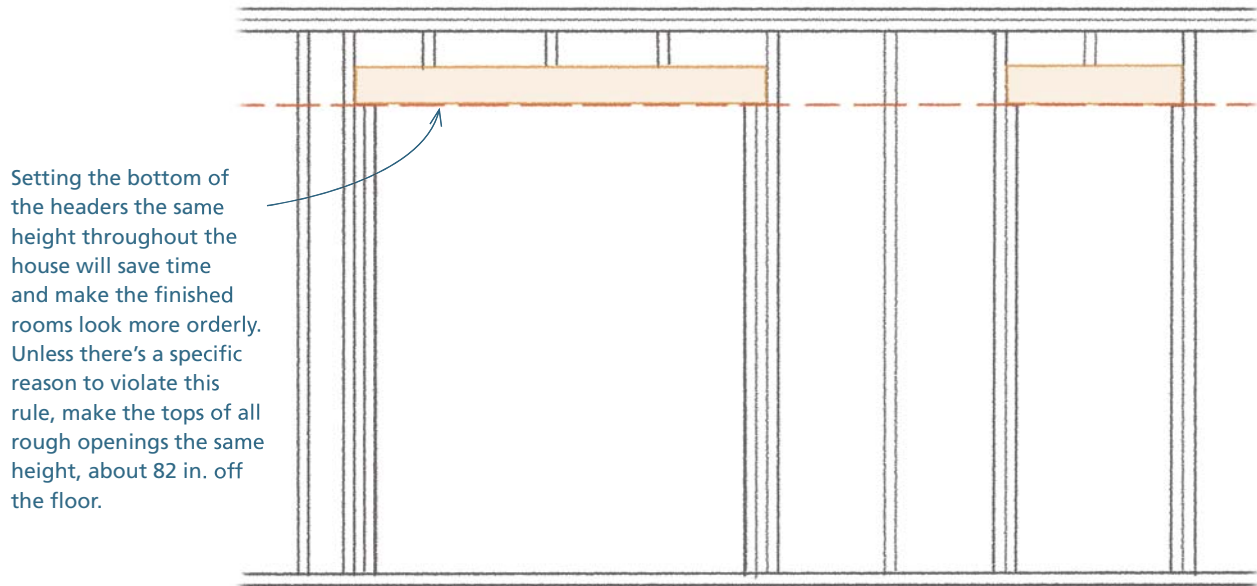

Build and Install Interior Walls

Interior walls are relatively light and don't need to be anchored to the layout line and squared like exterior walls. Build them in one place, then slide them into position in another place. (Doing this is sometimes necessary because the braces holding the exterior walls are in the way.)

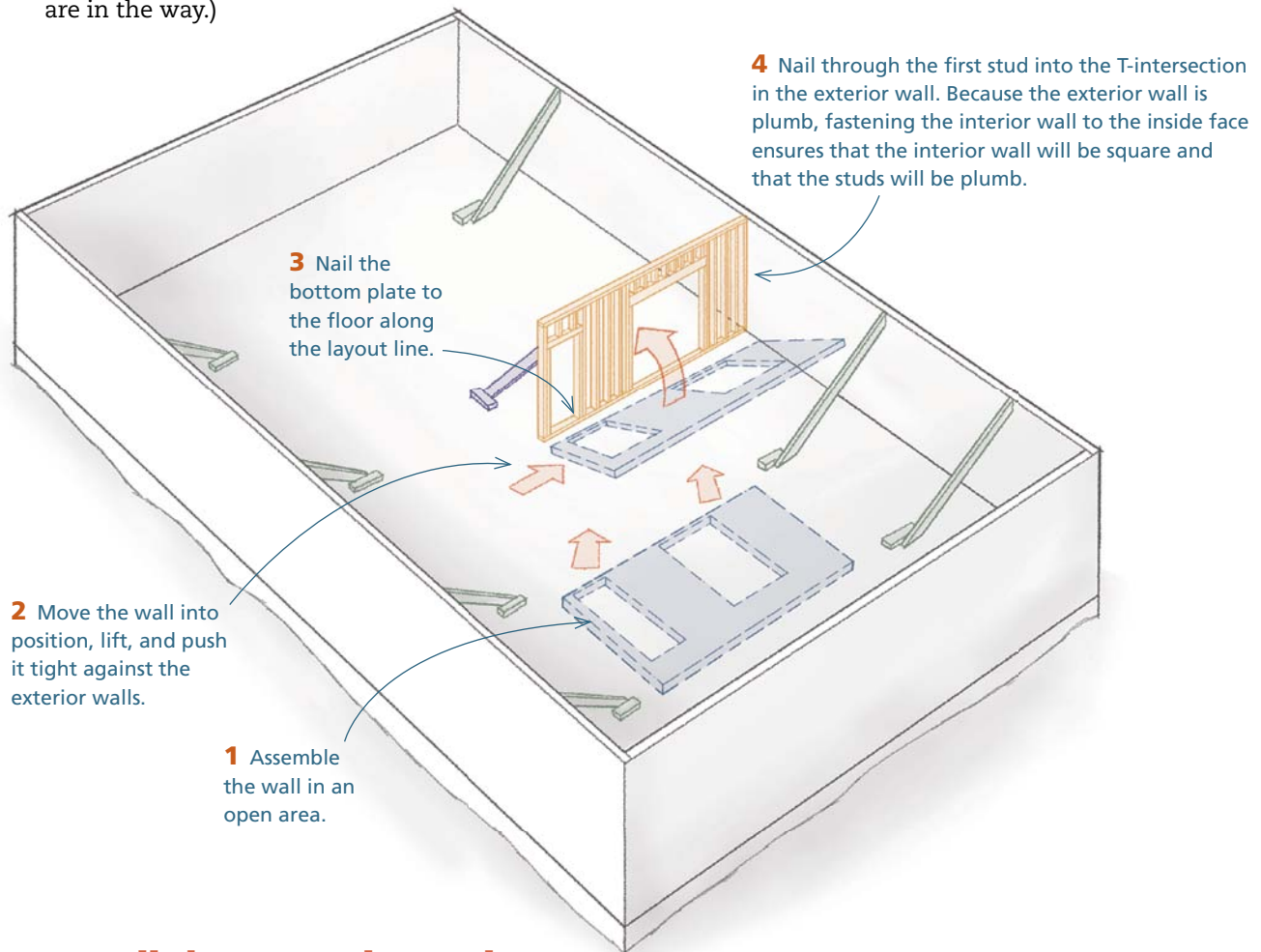

Install the Second Top Plate

The second top plate ties the walls together and makes them more rigid. Where walls intersect, run the second top plate across the intersection of the plates.

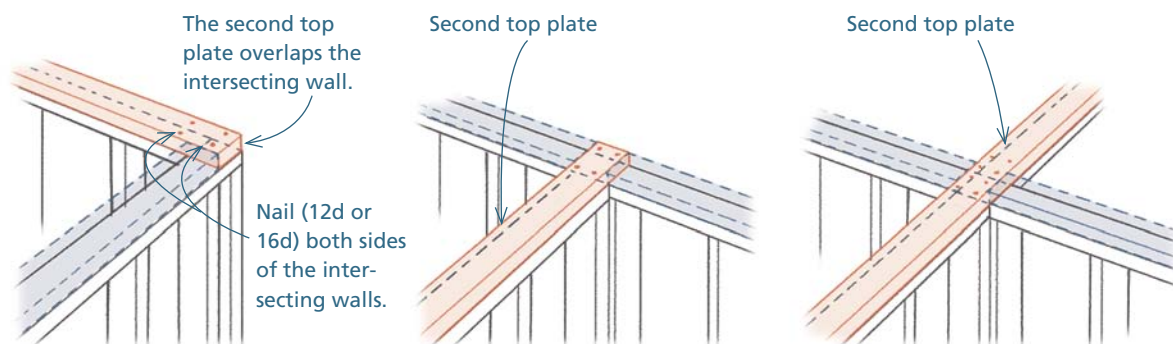

Blocks and Backing

• FIRE BLOCKING

Fire blocking is required by code in walls at the floor and ceiling of stud bays and at 10-ft. intervals in walls that are more than 10 ft. tall.

Install fire blocks at the ceiling level (about 8 ft. off the floor) in a gable wall that extends from the bottom plate to the underside of the rafters.

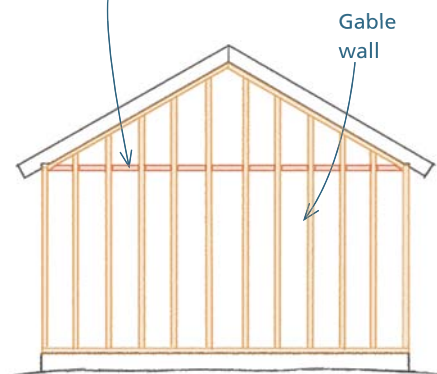

Fire blocking is also required to close off stud bays from cabinet soffits and dropped ceilings.

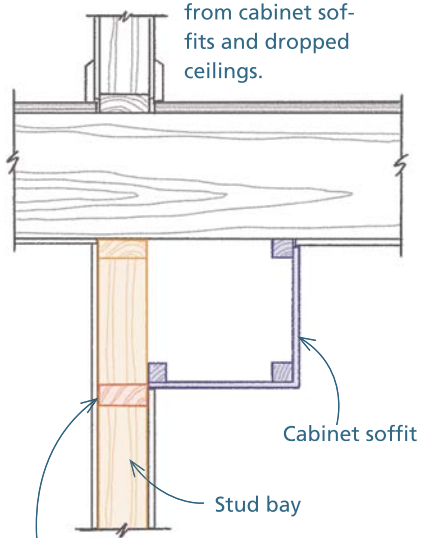

Install the blocks lying flat to close off the bays.

• BATHROOMS

Many blocks are needed in an average home. To keep from overlooking any, generate a checklist, bring it to the job, and consult it as you install the blocks. Keep notes to locate the blocks after the drywall has been installed. Another way to locate the blocks is to mark their location on the floor.

Shower curtain lengths vary between 72 in. and 78 in. long. Set upright blocks in bays in line with the front side of the tub. Center the blocks at 77 in. off the floor for standard shower curtains and 83 in. off the floor for oversized curtains.

Blocks are needed at the front of tub or shower units on the side wall (or walls) to receive fasteners for the wall covering.

Where tile backer board is used, the best practice is to provide solid backing at the horizontal seams. Install blocks in an upright position.

If grab bars are planned, install blocks to receive fasteners for them.

Blocks are needed to receive fasteners for the flange of fiberglass tubs and showers, and for drywall or tile backer board above the unit.

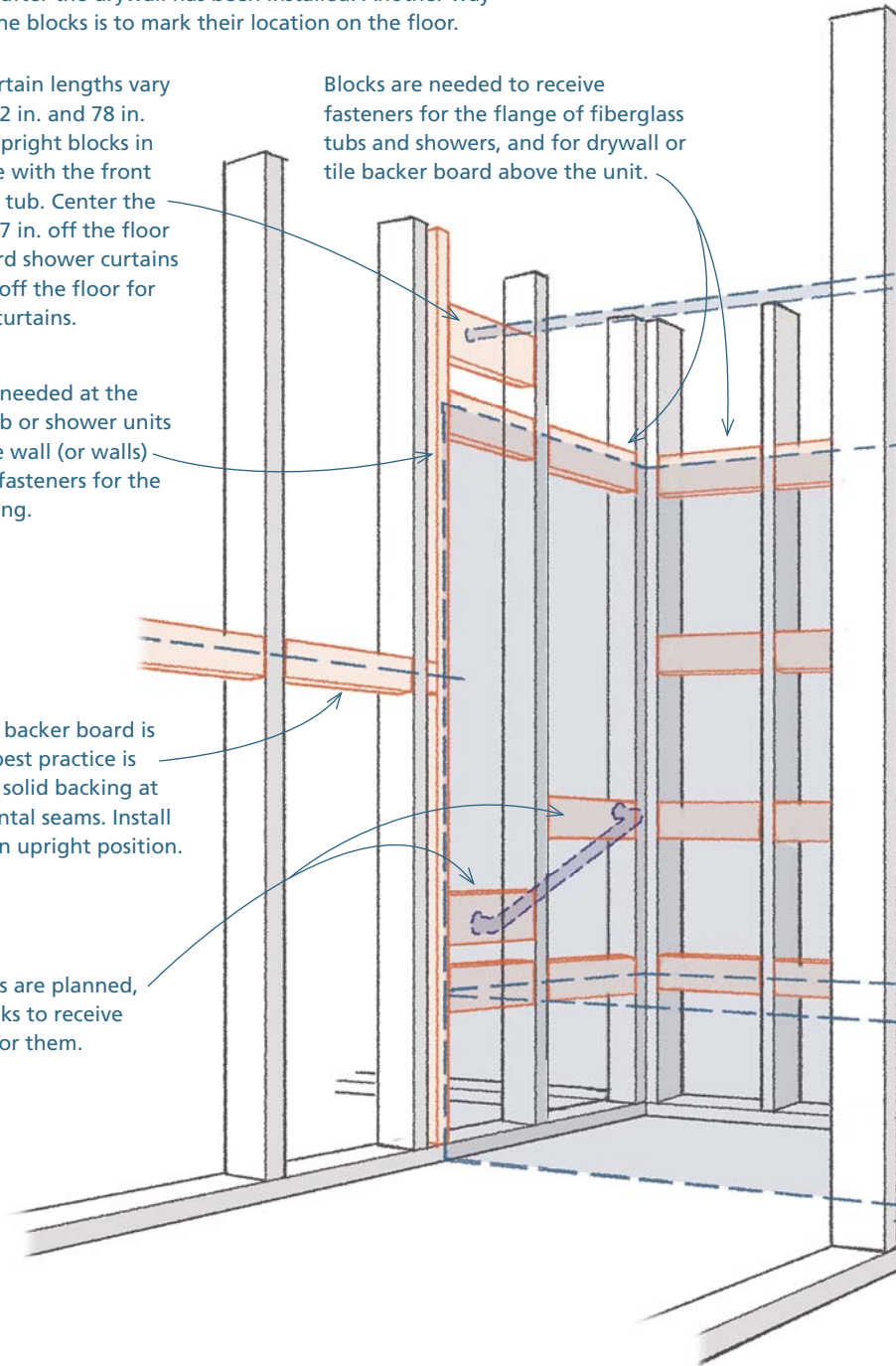

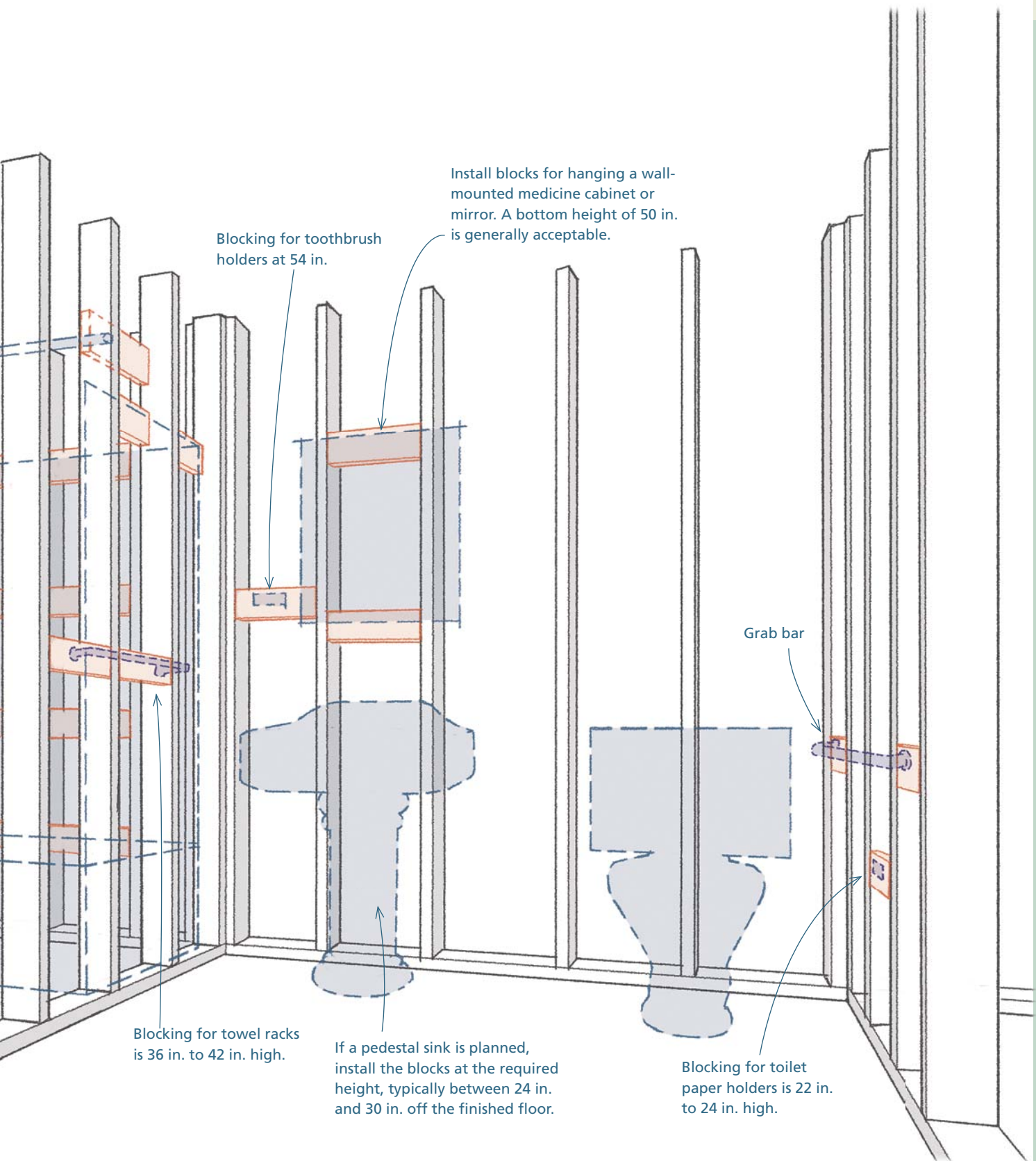

Blocks and Backing (continued)

• STAIRCASES

The wall beside a staircase often needs blocking to accept screws for the handrail. To lay out the location of these 2x8 blocks, follow this procedure:

3 Mark the stud along the top of the 24-in. leg of the square to mark the height of the block.

2 Set a framing square with the 16-in. leg resting on the level and the 24-in. leg at a right angle to the level.

1 Place a level so that it rests on the noses of the treads and follows the incline of the stairs.

4 Mark the stud at the top of the staircase.

5 Snap a chalkline from mark to mark.

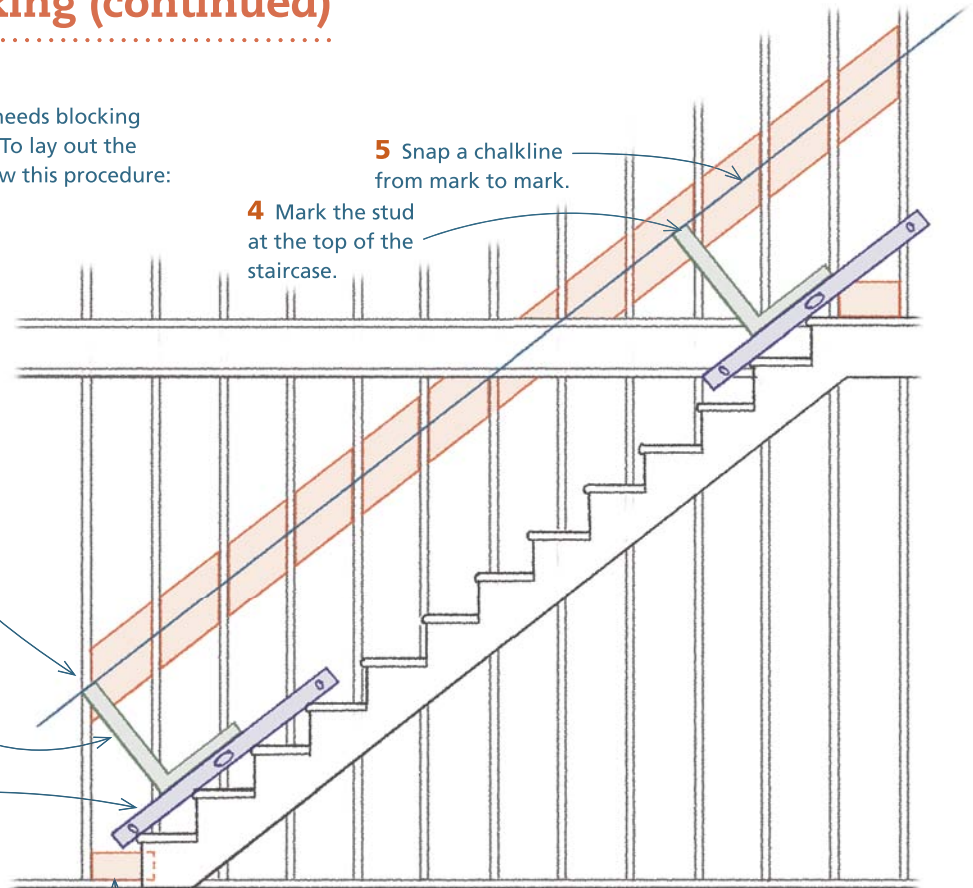

If the skirt of the stairs ends in the middle of a stud bay, install a block to catch fasteners, drywall, and baseboard.

• DOOR CASINGS AND CABINETS

Provide a nailing surface for wide door casings. Nail a short 2x block to the face of the king stud. If a chair rail is planned, make the block long enough to catch both the baseboard and the chair rail.

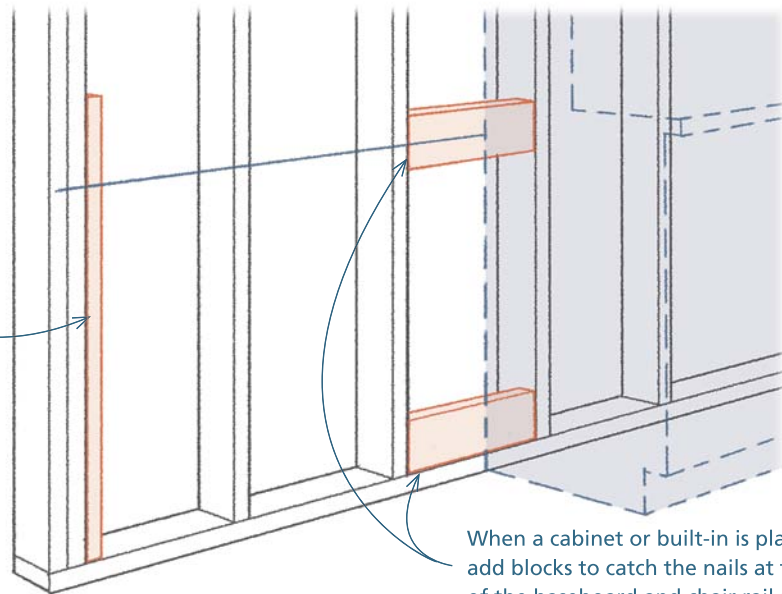

When a cabinet or built-in is planned, add blocks to catch the nails at the end of the baseboard and chair rail (typically 33 in. off the finished floor).

• CEILINGS

When a wall runs parallel to the ceiling framing and the wall is located between the joists, perpendicular blocks are needed for two reasons. They tie the top of the wall to the ceiling and thus hold it rigidly in place. And they provide nailing surfaces for the drywall on the ceiling.

OPTION 1

Place blocks in a modular pattern (usually 16 in. o.c.). Make sure the blocks are located where the drywall will meet.

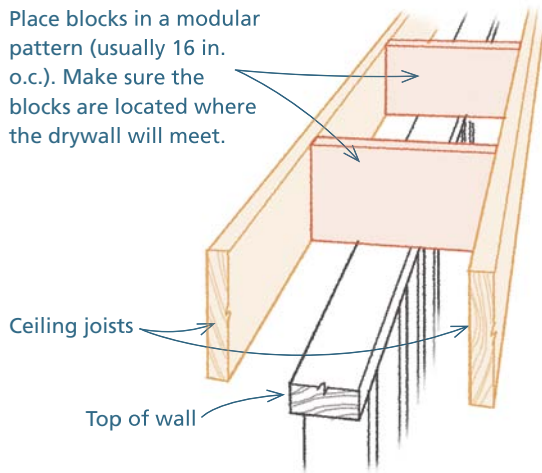

Where a wall that runs perpendicular to the ceiling joists terminates between joists, install a block between the joists at the end of the wall. It will catch drywall nails or screws.

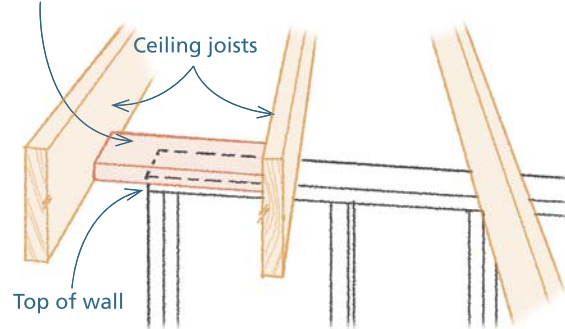

OPTION 2

Install blocks perpendicular to the ceiling joists.

Place 2x6 or 2x8 boards centered on top of the wall to provide solid nailing for ceiling drywall on both sides of the wall.

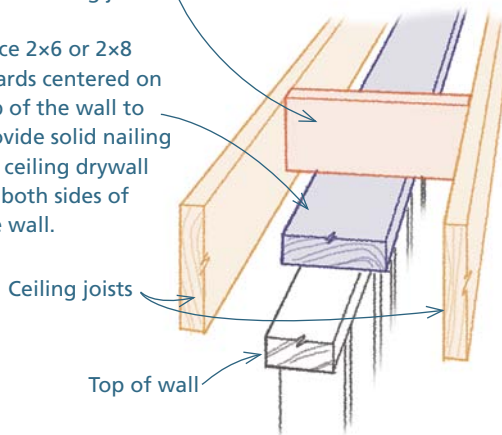

Sometimes cabinets or built-ins end within a ceiling joist bay. Typically, the ceiling drywall is installed before these are built, so nailing surfaces for drywall are not a concern. If you plan to install crown molding, however, you need to install perpendicular blocks to provide solid nailing surfaces.

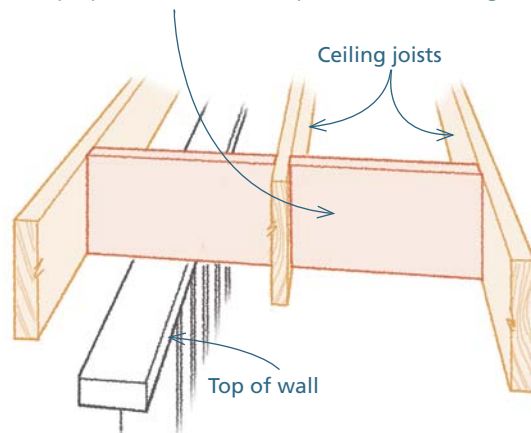

• BACKING

The purpose of building T-intersections and corners is to provide backing (a solid nailing surface) for inside corners. It's easy to miss some backing, however, especially when the plan for the frame has been modified during construction. Before surrendering the frame to the mechanical contractors, go through the house and look at every inside corner to make sure there is a surface upon which to attach the drywall. Look closely at closets, cabinet soffits, and other small parts of the frame where backing may have been overlooked.

Framing the Ceiling

Not all houses require ceiling framing; where trusses are used, the bottom chords of the trusses serve as the ceiling. Framed ceilings are required, however, where rafters are used for the roof system; the underside of the second floor on a two-story house also serves as a ceiling. With a few exceptions, ceilings are built much like floors.

Ceiling joists with a framed roof

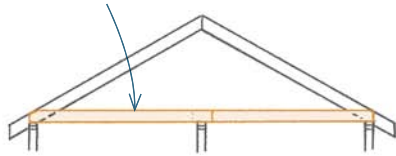

The bottom chords serve as ceiling joists.

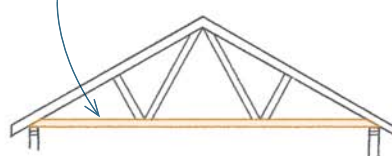

The second floor serves as ceiling joists.

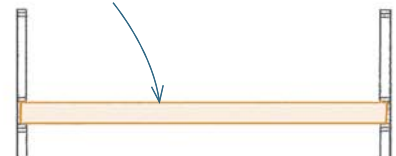

Lay Out the Ceiling on the Top Plates of the Walls

Ceiling joist locations must be laid out on the top plates of the walls. Joists are usually laid out 16 in. on center. Typically, a bearing wall near the center of the house carries half the weight of the ceilings.

1 Pull all layouts from the same end of the house.

4 The layout on the second exterior wall must be 1/2 in. behind the layout on the bearing wall.

Joists should overlap over the bearing wall a minimum of 3 in.

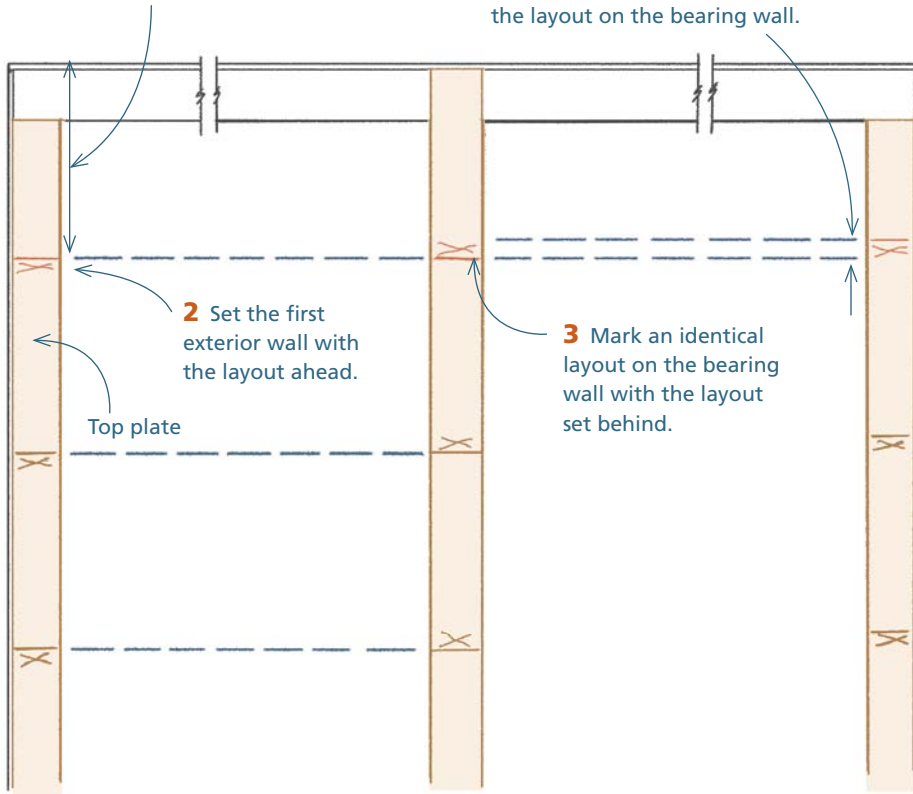

2 Set the first exterior wall with the layout ahead.

3 Mark an identical layout on the bearing wall with the layout set behind.

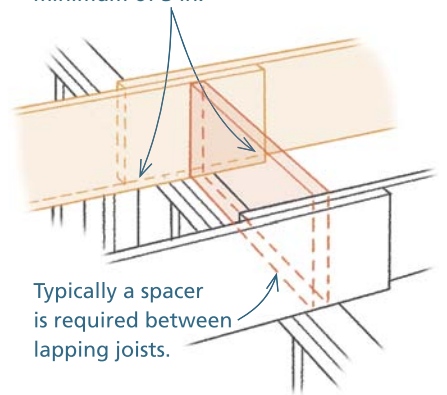

Typically a spacer is required between lapping joists.

Or, keep joists in line and butt them over the bearing wall.

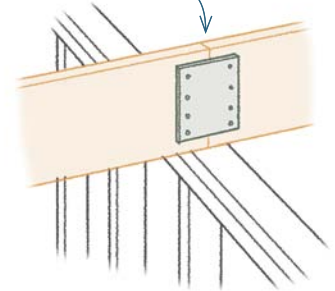

Large Openings

Just as with the floor system, you have to lay out and build large openings in the ceiling, such as stairwells, attic-access openings, chimney openings, and HVAC chases, with double trimmers, headers, and the appropriate hangers.

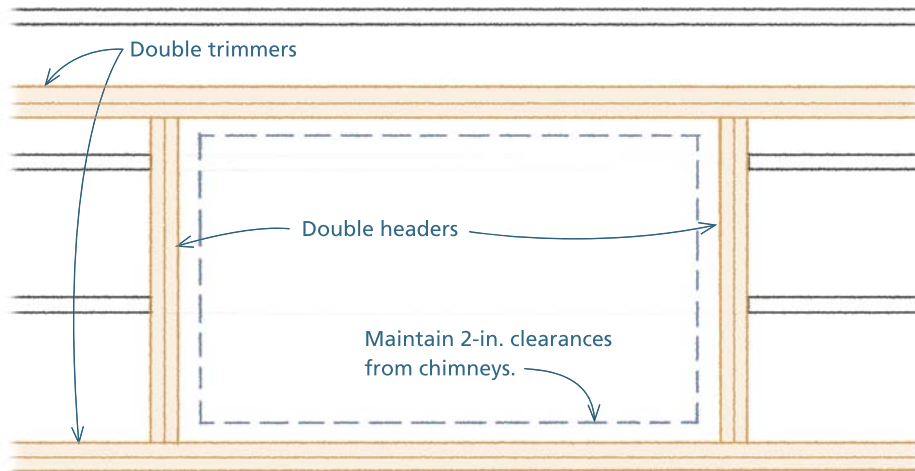

Anticipate the Needs of Plumbers and Electricians

Ceiling joists that run perpendicular to the walls below don't impede the work of plumbers and electricians. However, ceiling joists that run parallel to walls can cause difficulties. Where plumbing vent lines are anticipated, don't put a joist directly on a wall that runs in the same direction as the joist.

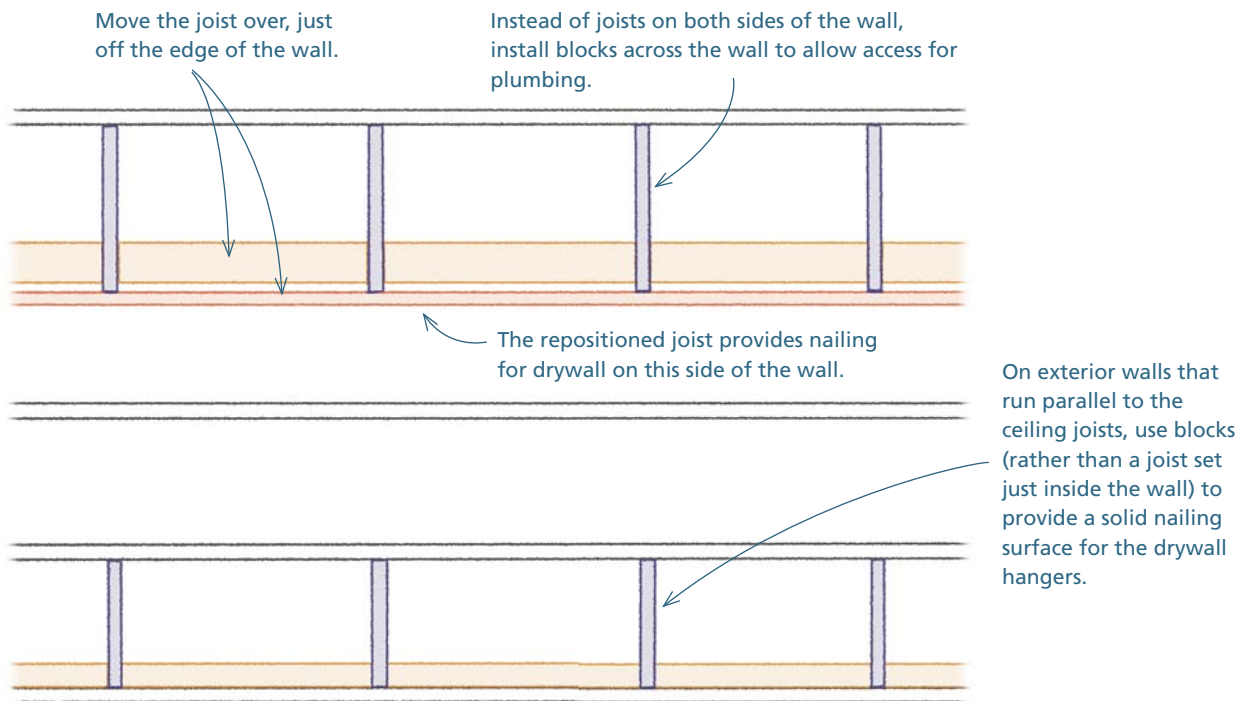

Cut Joist Ends to Conform to the Pitch of the Rafters

In some cases, the ends of floor joists have to be cut to prevent them from protruding above the plane of raftered roofs. Before you install the joist, find out what material will be used for the rafters and what will be the pitch. For more on roof pitch and techniques for cutting rafters, see chapter 3.

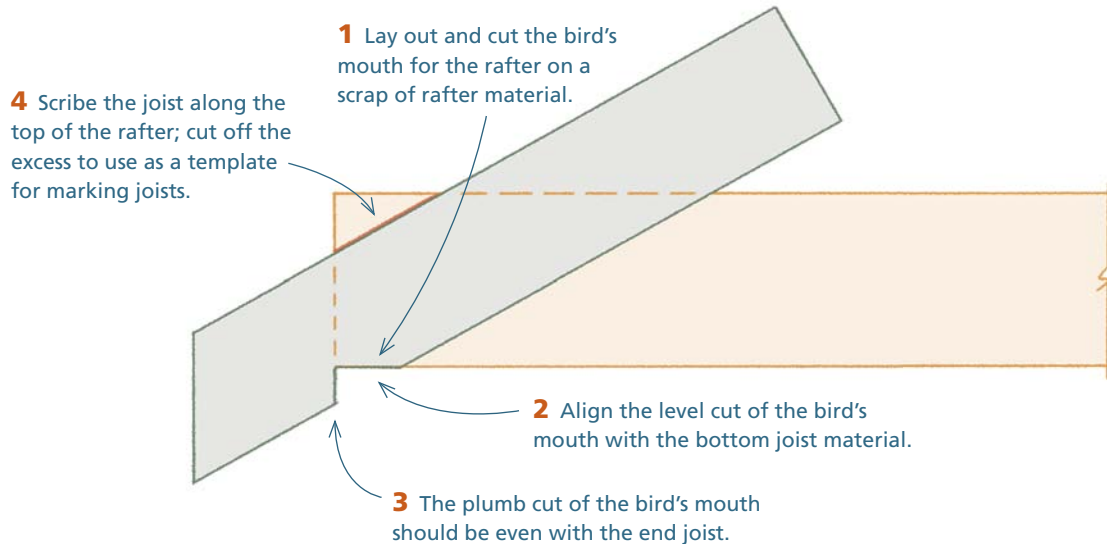

Installing Ceiling Joists

Install ceiling joists with the crown up. Unlike floor systems, ceiling frames don't have rim joists. Because of this, ceiling joists generally extend to the outside of the wall. Toenail the ceiling joist to the top plates of the bearing walls using two or three 8d nails at each connection. On raftered roofs with nonstructural ridges, the joists must resist the thrusting forces exerted by the rafters. In these designs, the connections between the joists and the rafters and the joists where they overlap over the central bearing wall are very important.

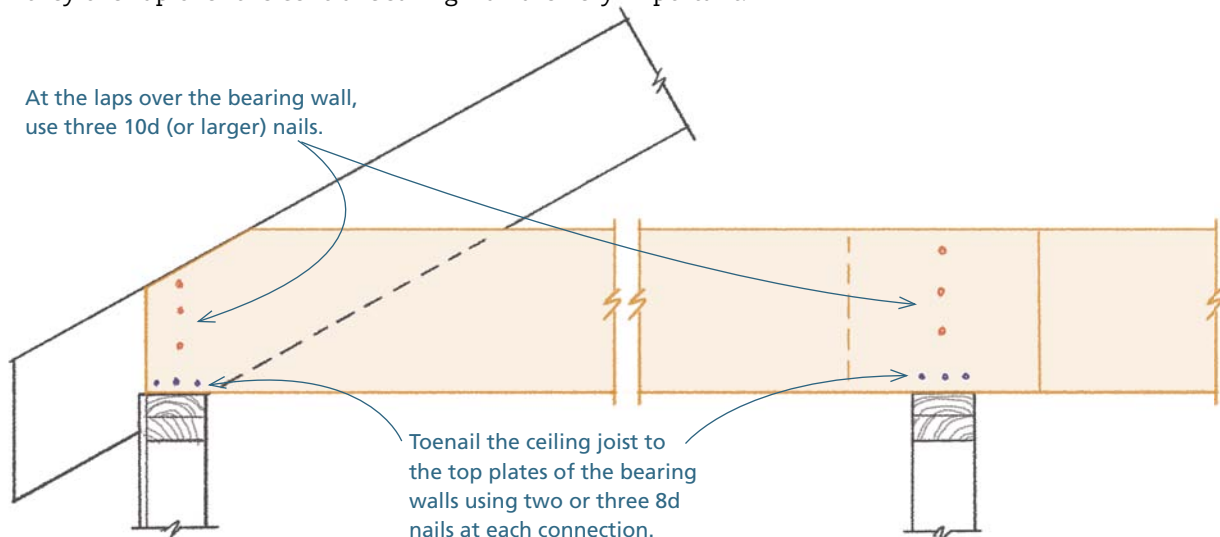

Framing a Gable-End Wall

In this section, we have to jump ahead and assume that the rafters have been installed. The procedure discussed here describes how to fill in the wall between the floor and the underside of the roof. It is assumed that the underside of the rafters will serve as the ceiling, often called a cathedral ceiling.

STEP 1 Install the plates

5 Snap a line from mark to mark. Cut and install the top plate along the chalkline.

3 Lay out these blocks 16 in. on center to provide solid nailing surfaces for the drywall.

2 Install blocks perpendicular to the two rafters above the plate. The blocks should be flush with the bottom edges of the rafters.

4 Plumb up from each end of the bottom plate and mark the blocks at those points.

1 Nail the bottom plate along the layout line on the floor.

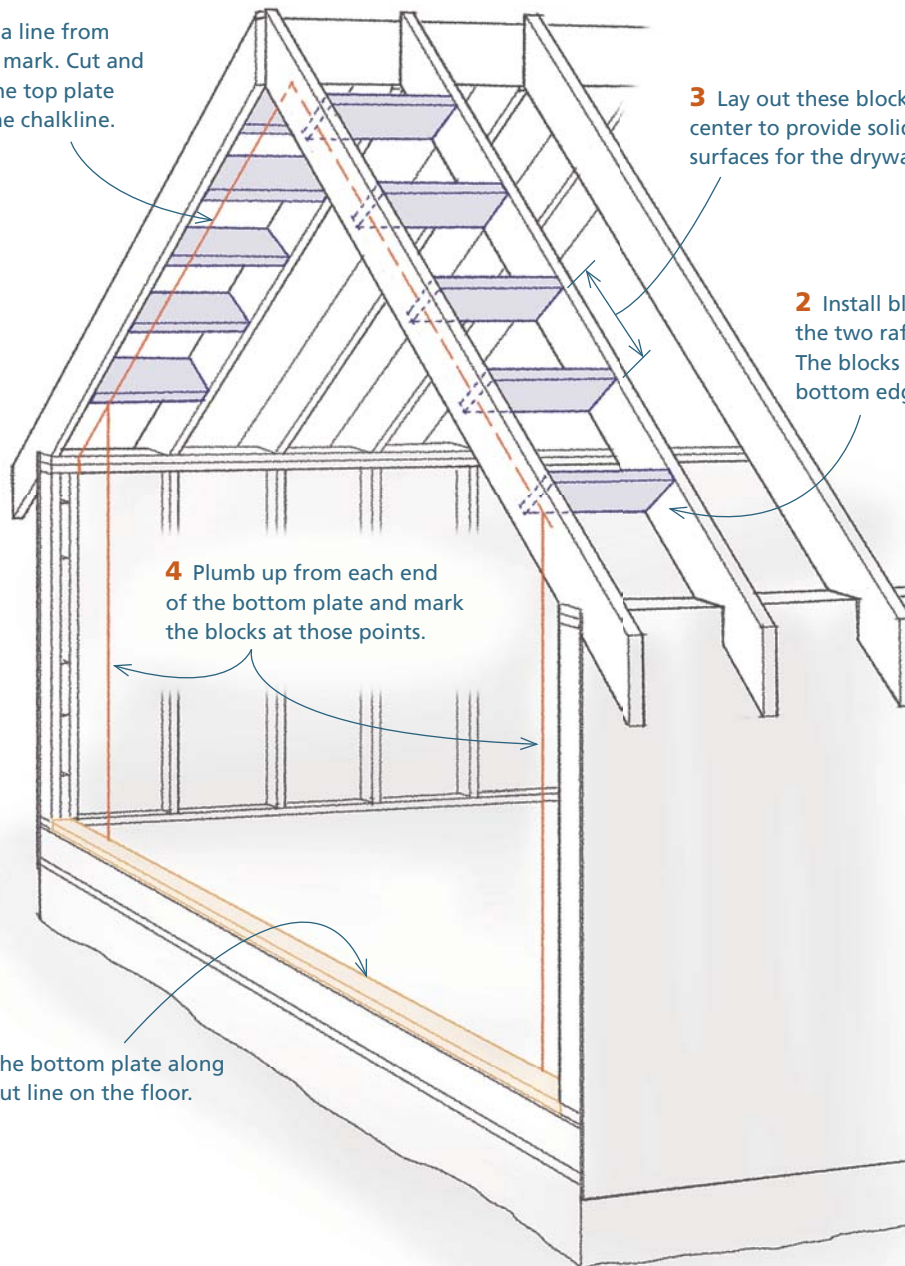

STEP 2 Lay out the details on the plates

Because the upper plate follows the pitch of the roof, it's always longer than the bottom plate. The intervals between the layout marks on the top plate, therefore, have to be proportionately longer than those on the bottom plate to maintain a pattern of plumb studs.

Use a level and a straight piece of lumber to transfer the layout up to the top plate. If you have a laser plumb bob, you can use that instead of the straightedge and level.

Mark the layout on the bottom plate in the usual manner.

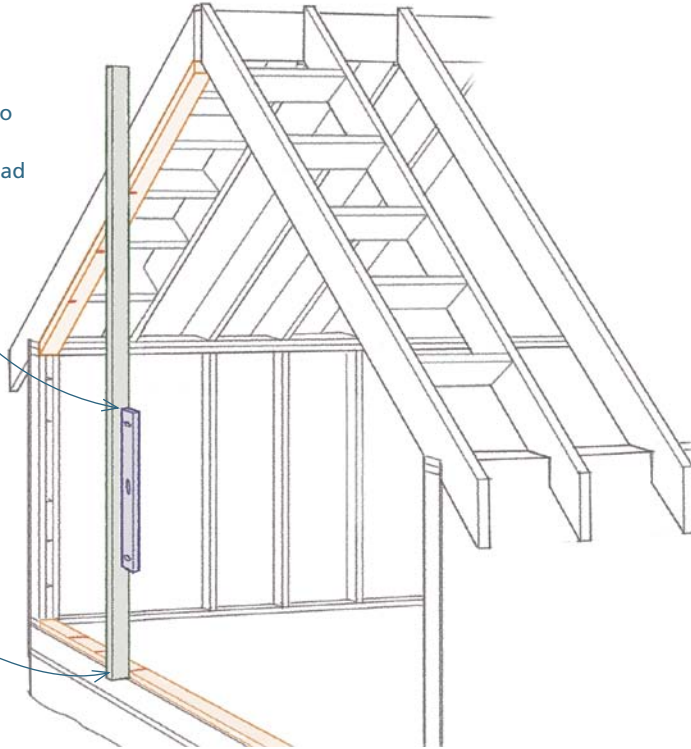

WAYS OF WORKING

Drawing the Pitch Triangle

If you want to avoid plumbing up from the bottom plate at each mark, you can make a drawing of the pitch and then measure off the drawing. To see how this works, let's say the pitch of the roof is 10-in-12. (For more on pitch designation, see chapter 3.) The stud spacing in this example is 16 in. on center.

4 Connect the marks with a straight line past the 10-in. mark; this line represents the roof pitch.

6 Extend a perpendicular line from the 16-in. mark through the roof pitch line.

5 Mark 16 in. from the 12-in. mark along the edge of the plywood.

7 The length of the roof pitch line, $20\frac{13}{16}$ in., is the length needed on the top plate to maintain a 16-in. stud spacing.

3 Mark 10 in. up the line.

2 From the line, measure and mark 12 in. along the edge of the plywood.

1 Mark a perpendicular line out from the factory edge of a sheet of plywood.

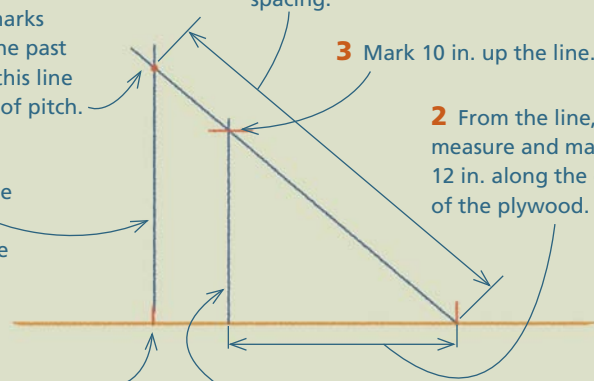

Framing Circular Shapes

• CIRCULAR WALLS

The main challenge in framing circular walls is to cut the circular top and bottom plates.

1 Use two layers of $\frac{3}{4}$ -in. plywood to equal the thickness of 2x sawn lumber.

3 Set a beam compass a distance equal to the radius; scribe the outer circumference of the plate.

4 Scribe the inner circumference of the plate (usually either $3\frac{1}{2}$ in. or $5\frac{1}{2}$ in.).

5 Assemble the plates, then install in place.

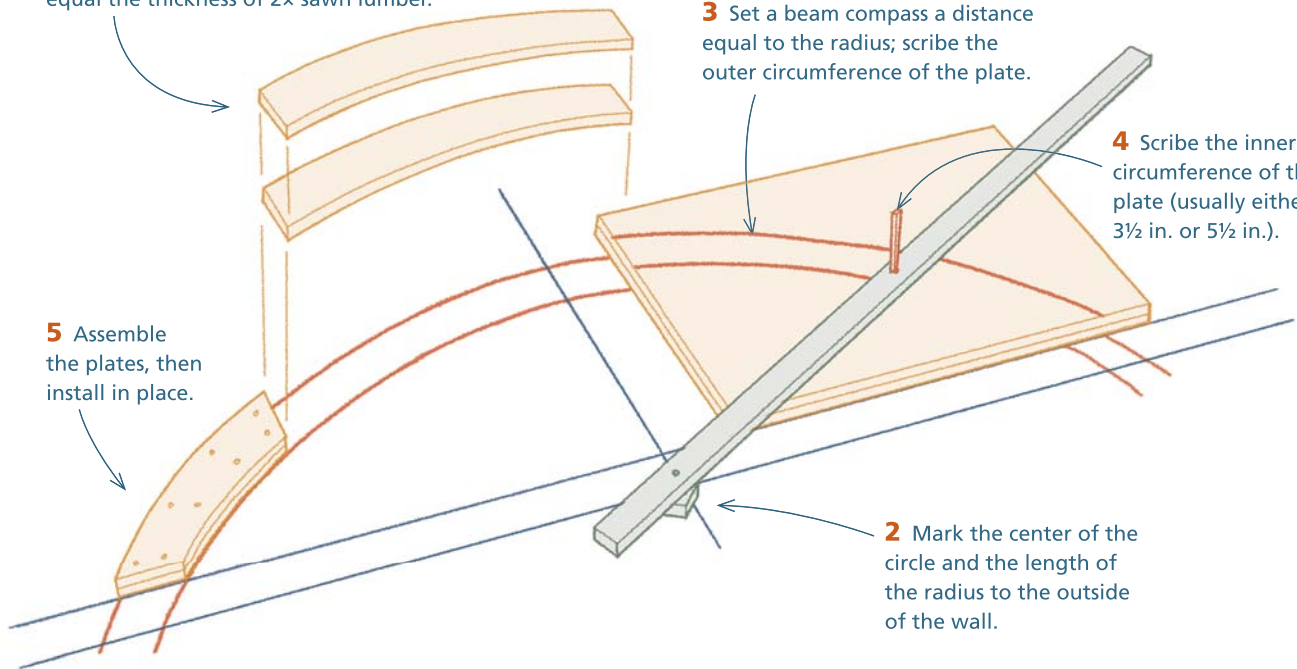

• FRAMING ARCHED OPENINGS

Like standard headers, arch-shaped headers can be built up in layers to match the thickness of walls. In many cases, you can use two 2x10s and one layer of $\frac{1}{2}$ -in. plywood to achieve the thickness of a 2x4 wall.

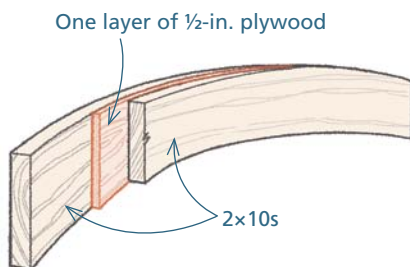

• LAYING OUT OCTAGONS

1 Lay out a square. The sides should be equal to the width of the octagon, as measured from one flat side to the opposing flat side.

3 Multiply the length of the side of the square by 0.207. The product is one-half the length of each side of the octagon.

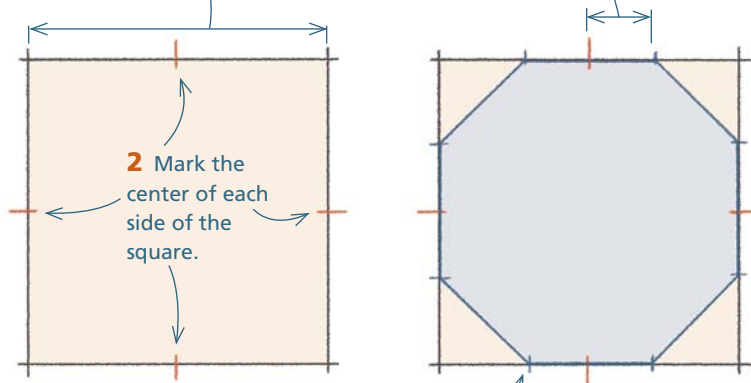

4 Measure out the distance (in step 3) from the center points in both directions to lay out the eight points of the octagon.

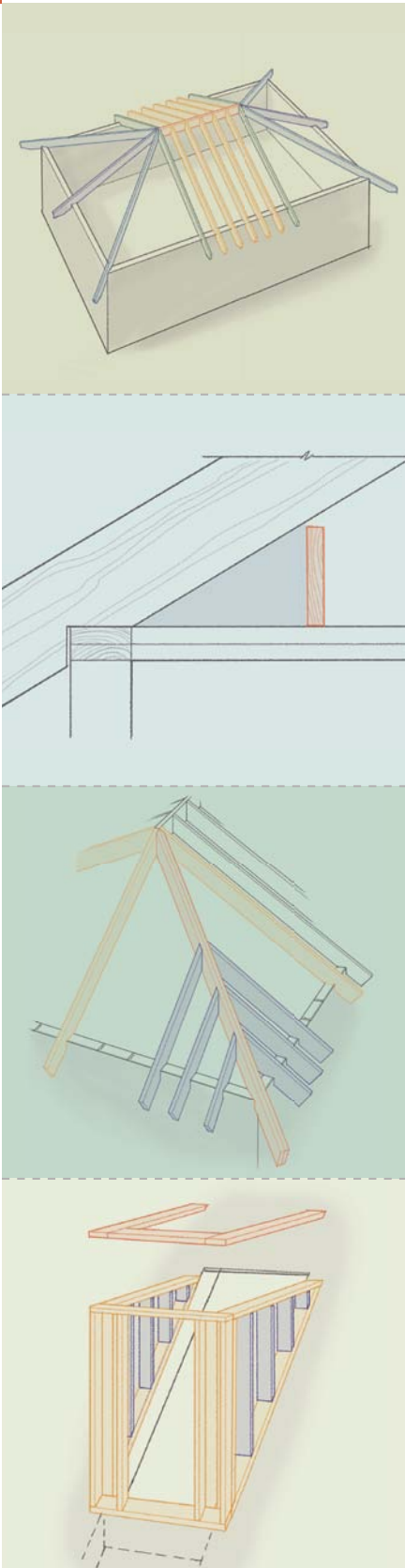

Framing Roofs 1: Raftered Roofs

FOR THOUSANDS OF YEARS, carpenters have built pitched-roof structures to shed rainwater. These structures present two challenges. First, they are often the hardest part of the frame to visualize and lay out. The sloped surfaces are neither plumb nor level, and the angles they create are more varied—and more complex—than the right angles that are repeatedly used in the walls and floors below.

Second, roofs are often the most difficult part of the frame to physically build. The roof is the highest point on the frame. Materials must be hauled up and then installed above the ceilings. This requires frequent trips up ladders and a lot of climbing around on an uneven surface.

There are two basic ways to frame roofs. For centuries, carpenters have “stick built” roofs, meaning they have constructed roofs by cutting lumber into rafters, ridges, and the other parts of traditional roof frames. For the last couple of generations, however, builders have relied increasingly on trusses, which are engineered and fabricated in plants and shipped ready-to-install to the job site. (For more, see “Rafters vs. Trusses” on p. 103.)

This chapter focuses on the framing of traditional, stick-built roofs. Chapter 4 discusses trussed roofs and also examines the details that complete the roof frame, including eaves and rakes and the installation of the roof deck.

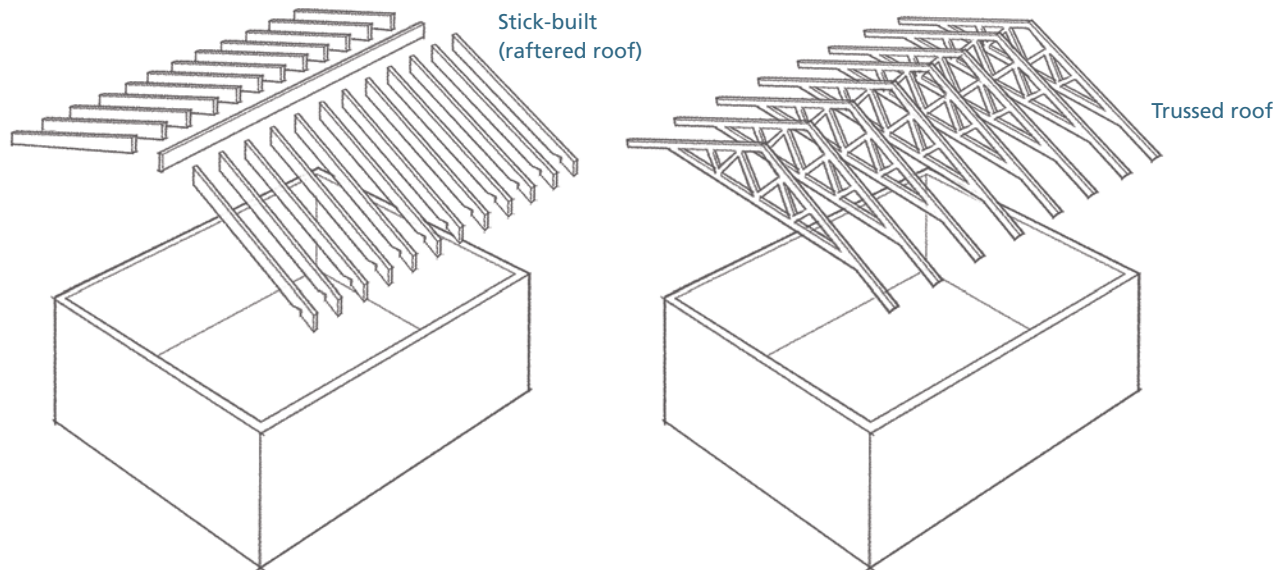

Raftered Roof Basics

Over the centuries, carpenters have given names to dozens of parts on every conceivable stick-built roof. The names of many of these are obscure, vary from region to region, and need not concern us here. There are a number of parts that are found on most stick-built roofs, however, and these need to be identified.

Parts of a stick-built roof

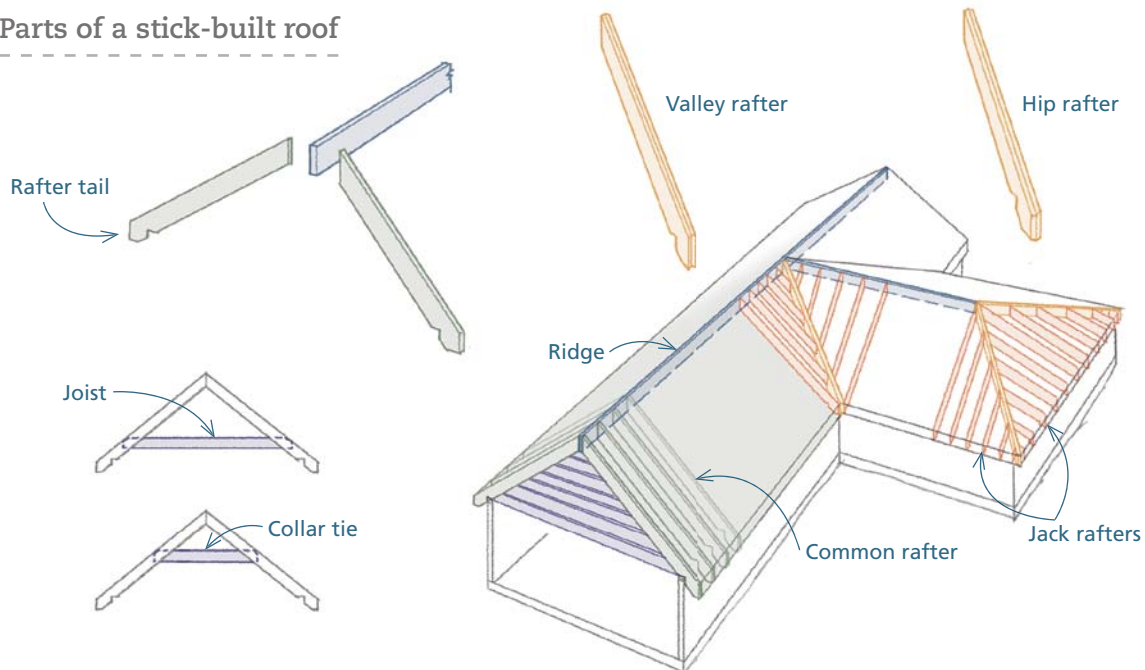

The Loads Carried by a Roof

The dead loads on most roofs are pretty small; because the roof is the highest part of the frame, it merely has to carry its own weight and the weight of the shingles (or other roofing material) installed over it. The live loads are a different matter. The roof takes the brunt of the weather and, in some areas, the live loads imposed by Mother Nature can be very large. If you're building in an area where heavy snow, high winds, or seismic events occur, the roof structure has to be designed and detailed to meet those conditions. As always, the best sources of this information are local building officials and local design professionals.

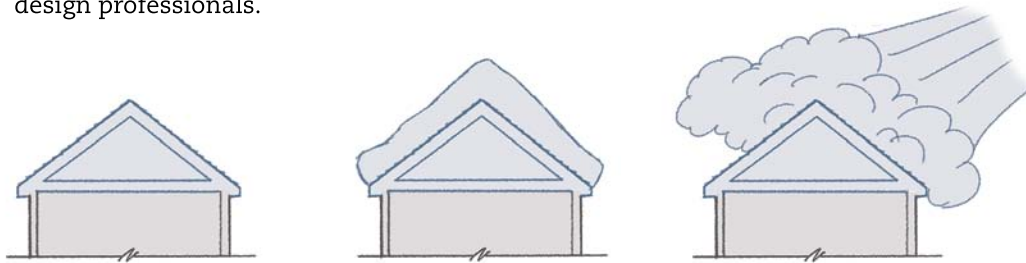

Two structural approaches

When architects and engineers design raftered roofs, they use one of two basic approaches. If they use a *structural ridge*, the ridge serves the same function as any of the other structural beams in the house. It has to be strong enough to carry the loads imposed on it, and it needs to be properly supported at each end. The posts that support the ends of structural ridges create point loads, and these loads have to be transferred via a well-conceived load path to the footing. Both the beam and the load path should be designed by an engineer or architect.

Structural ridges are heavy and expensive, and the main reason designers specify them is to open up the space below the roof. With a structural ridge, there is no need to restrain the bottom ends of rafters from spreading and, hence, no need to specify joists or collar ties. Designers often specify structural ridges, therefore, when they want to create cathedral ceilings.

The second approach to raftered roof structure uses *nonstructural ridges*, which are lighter and less expensive than structural ridges. Nonstructural ridges serve mainly as convenient surfaces to attach opposing pairs of rafters. The rafters lean against one another, with the ridge sandwiched between them. In essence, the load on one side is offset by the load on the other. The ridge, which can be as thin as $\frac{3}{4}$ in., doesn't hold this weight up; instead, it simply serves as a surface to press against.

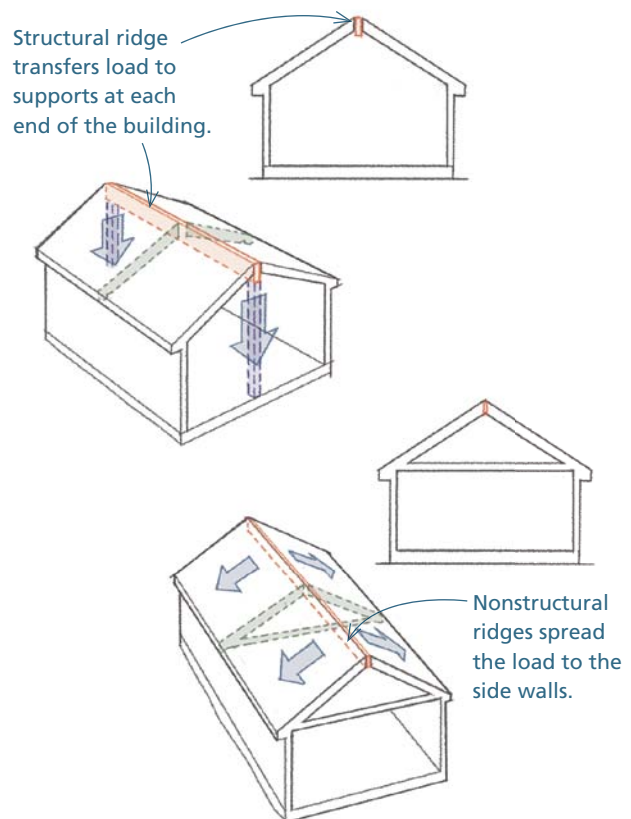

With the ridge doing little to hold up the rafters, there is a strong tendency for the ridge to sink and the bottom ends of the rafters to push out. Here is where the ceiling joists or, in some cases, exposed beams or cables come into play. They run across the span of the building and tie the bottoms of opposing rafters together. If the bottoms can't thrust out, the top can't sink.

Because restraining the outward thrust of the rafter bottoms is an essential part of the structural scheme, it is extremely important to know and follow the fastening schedule at the rafter/joist intersection. On many houses and additions, there is an equally important connection toward the center of the structure. Where single joists or beams cannot span the entire width of the structure, carpenters need to overlap two pieces—usually over a central wall. These overlapping pieces must be properly connected; otherwise, the bottoms of the opposing rafters will not be tied together. Be sure, then, to follow the fastening schedule specified for this connection, too.

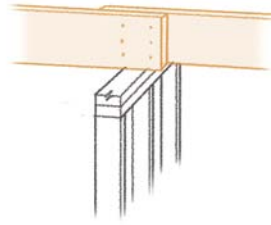

Overlapping pieces must be properly connected to resist outward thrust from the roof load.

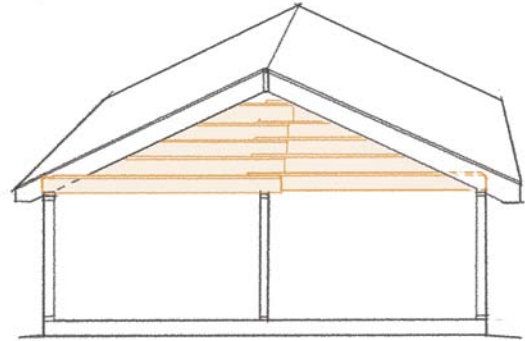

Roof Pitch

The pitch of the roof largely defines the shape of the house and thus has a big impact on its appearance. It also affects the structural design, the layout of rooms below, and how well the finished roof will shed water. The choice of pitch, therefore, should not be taken lightly; it's an important decision that should be thought through during the design phase of the job.

How pitch is designated

In the United States, pitch is designated as the ratio of the rise to the run, with the run being 12. Although it's reasonable to assume that this designation arose from our use of the foot, it's important to remember that this ratio remains the same no matter what measuring unit is used. A 6-in-12 roof, for example, rises 6 in. for every 12 in. of run; 6 ft. for every 12 ft. of run; or 6 yd. for every 12 yd. of run. For that matter, a 6:12 roof rises 6 cm for every 12 cm of run. So long as the measuring unit is the same for both parts of the ratio, you can use any unit you like.

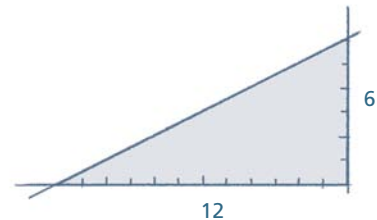

Pitch and degrees of an angle

Although American builders normally describe the pitch of a roof in a 12-based ratio, most carpenters have saws with angle settings that are designated in degrees. It's important, then, to know how to go from pitch to degrees and back again. There are many ways to make these conversions; the sidebar on p. 104 shows three ways to convert a 4-in-12 pitch into degrees using both graphic and mathematic techniques. (See also "Converting X-in-12 Roof Pitch to Degrees of an Angle" on p. 504.)

Rafter Cuts

There are several kinds of cuts required for roof framing. Here are the most common.

Miter and bevel cuts

Miters are angles that run across the face of a board. In roof framing, miters are usually cut with a circular saw set to 0° .

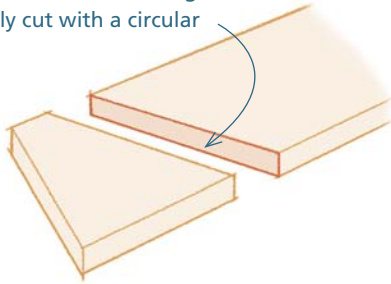

Bevels are angles laid out across the thickness of a board. A bevel can be ripped along the length of a piece of lumber, cut across the width of the board, or cut along a miter.

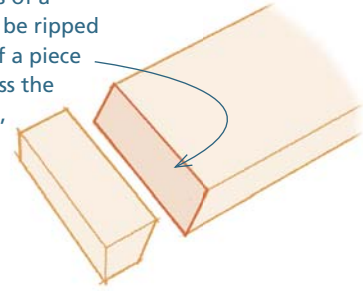

Reference points on miters and bevels

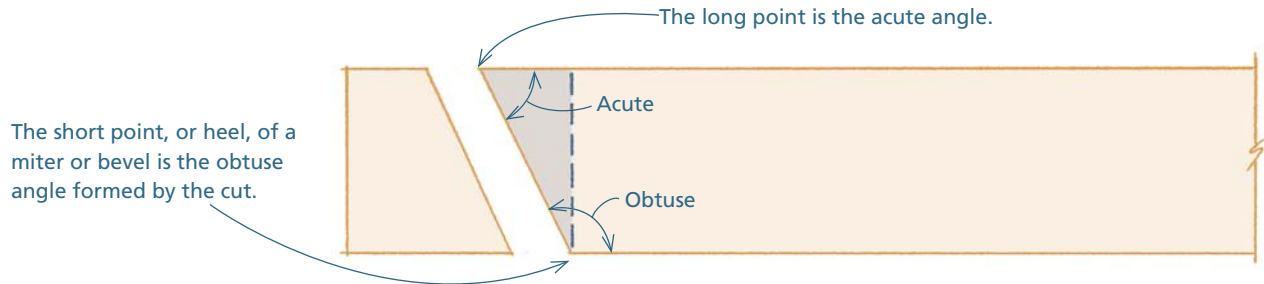

The short point, or heel, of a miter or bevel is the obtuse angle formed by the cut.

The long point is the acute angle.

Plumb, level, and bird's-mouth cuts

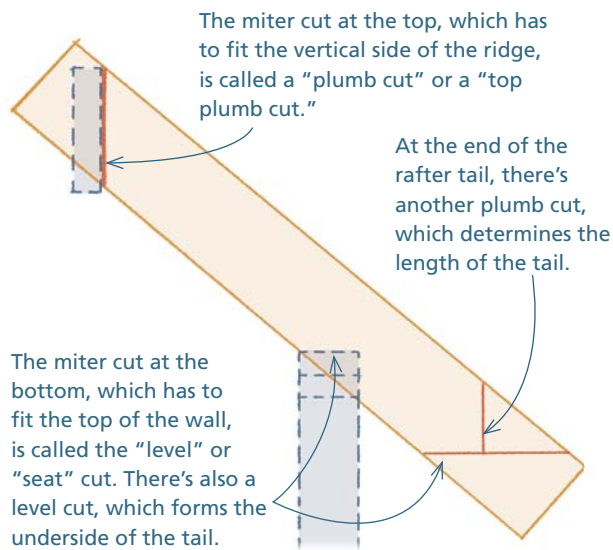

The miter cut at the top, which has to fit the vertical side of the ridge, is called a "plumb cut" or a "top plumb cut."

At the end of the rafter tail, there's another plumb cut, which determines the length of the tail.

The miter cut at the bottom, which has to fit the top of the wall, is called the "level" or "seat" cut. There's also a level cut, which forms the underside of the tail.

The notch in the rafter that fits the top of the wall is called a bird's-mouth cut.

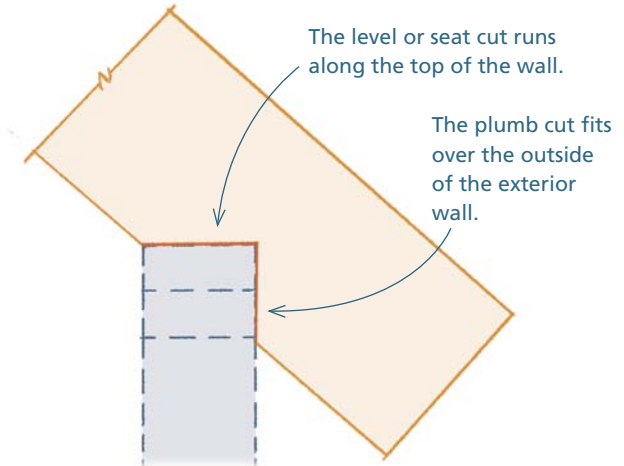

The level or seat cut runs along the top of the wall.

The plumb cut fits over the outside of the exterior wall.

Rafters vs. Trusses

There are many factors to consider when choosing between rafters and trusses for the roof frame: the effect that the designer wants to achieve; the size and skill of the crew that will frame the roof; the budget and schedule of the job; and the amount of space available around the building.

● RAFTERS

Use of space

In conjunction with a structural ridge, you can build rooms with cathedral ceilings. If you use a nonstructural ridge, you can make full use of the space between the joists and the rafters. The size and openness of the rooms under raftered roofs are limited by the spans of the rafters, joists, and, sometimes, structural ridges.

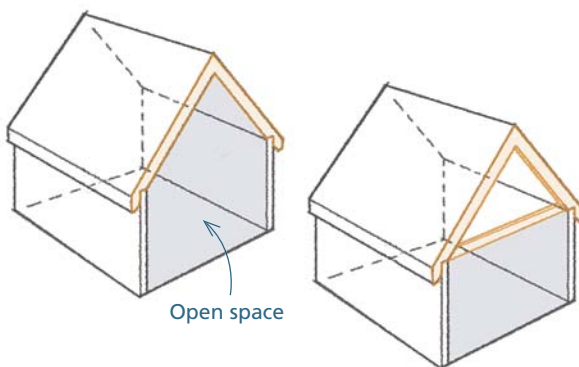

The crew

The layout for raftered roofs is one of the most difficult layouts in frame carpentry. The individual pieces of the frame are fairly light, however, and one or two carpenters can usually move them around and install them with little difficulty.

Budget, schedule, and job-site conditions

On small jobs, it's often easier to use rafters. There's no lead time and no need to set up a large crew or a crane. On some restricted sites, rafters are the only option—both because there's no room to maneuver a crane and because there's no place to store trusses. In general, rafters are lighter and more flexible in use; these attributes make them popular with remodeling contractors and custom builders.

● TRUSSES

Use of space

Engineers can design trusses that are capable of spanning very long spaces between bearing walls. This permits the rooms beneath to be large and open. Trusses can be made for cathedral ceilings ("scissor trusses"), but the effect is less spectacular than those created by rafters.

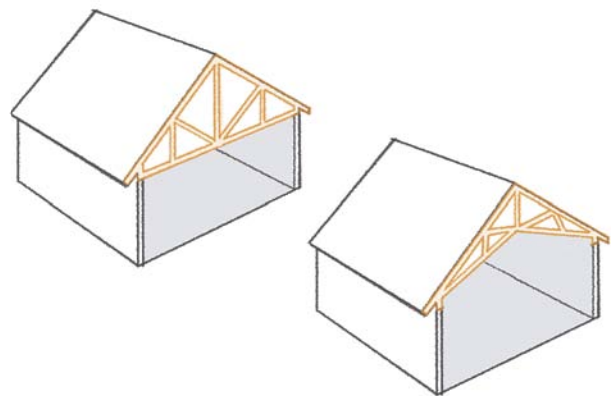

The crew

The layout for trussed roofs is usually straightforward. This does not mean, however, that installing trusses is not challenging. Because trusses have to be ordered in advance, the builder needs to have good organizational and communication skills. Trusses are large, heavy, and unwieldy. Getting them hoisted, set, and braced is a logistic challenge, which often requires a large crew and a crane.

Budget, schedule, and job-site conditions

It's not possible to say whether trussed roof systems are less expensive than raftered roof systems because there are so many variables in building design. Residential builders, however, have voted with their wallets on this issue. Accounting for about three-quarters of the roof systems in new houses, they are the heavy favorite in housing developments, even high-end developments. Large building developers are equipped for trusses; they usually have plenty of space, lifting equipment, and large crews. In these circumstances, trussed roof systems go together in a matter of hours.

Rafter Cuts (continued)

Compound angles

Jack rafters, which terminate at a hip or valley, have to be cut at compound angles. These angles are created by laying out a miter on the lumber and setting a bevel on a circular saw. If you have a compound miter saw, you can set both the miter and the bevel on the saw.

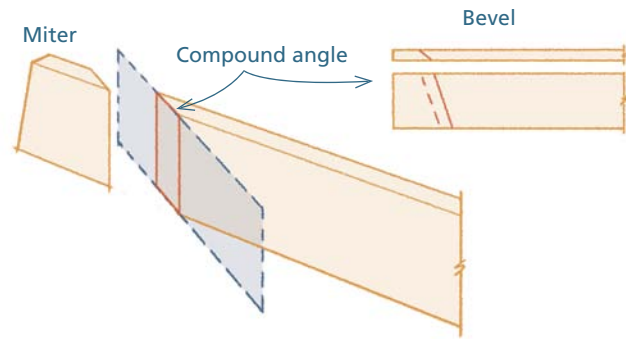

Bevels that conform to the pitch

On some roofs, it's desirable to rip the top or bottom edges of horizontal pieces at an angle that's equal to the pitch. Among these pieces are ridges, headers, and subfascias.

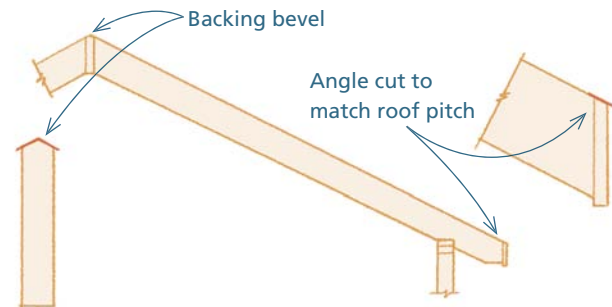

Backing bevels

The top and the bottom edges of hips and valleys are sometimes ripped at an angle to bring them into plane with the rest of the rafters. The angle at which they are ripped is called the backing angle.

WAYS OF WORKING

Three Ways to Convert Pitch to Degrees

● PROTRACTOR

To find the degrees of a 4-in-12 pitch, use a framing square to mark the 4-in. altitude and 12-in. base. Connect the hypotenuse.

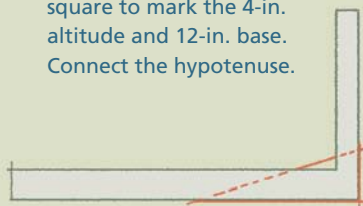

Use a protractor to measure the acute angle formed by the base and hypotenuse, about 18.5°.

● ROOF PITCH SQUARE

Hook the corner of the fence on a board and rotate square until 4 on the common pitch scale aligns with the edge of the board.

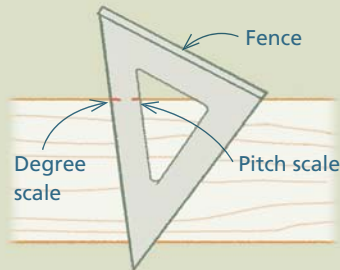

The degree scale should read about 18.5°.

● MATH

If you're using a scientific calculator, divide the rise of the pitch by 12, then multiply the result by tan-1. Here's the formula and the math:

$$\begin{aligned} \text{rise/run} \times \tan^{-1} &= \text{degrees} \\ 4/12 &= 0.3333 \quad 0.3333 \times \tan^{-1} = 18.43^\circ \\ \text{To go from degrees to pitch,} \\ \text{use this formula:} \\ \text{degrees} \times \tan \times 12 &= \text{rise of pitch} \\ 18.43 \times \tan &= 0.3333 \\ 0.3333 \times 12 &= 3.9999 \end{aligned}$$

Building a Gable Roof

The basic gable roof is one of the most common roofs in the world. In this example, the house is 24 ft. wide (24 ft., 1 in. when the thickness of the sheathing is included). The plan specifies 2x6 walls and a roof with a 6-in-12 pitch. The lumber specified for this roof consists of 2x8s for the rafters and joists and a 2x10 for a nonstructural ridge. At the bottom of the roof, the architect has drawn an eave and noted that the frame of the rough eave should end up 12 in. out from the framed wall.

At this point, you've built, raised, straightened, and braced the two exterior 2x6 bearing walls. You've also raised and braced off a 2x4 center bearing wall. A few measurements at the tops of the walls confirm that the three walls are parallel to each other and the specified distance apart. Above these walls, there is nothing but blue sky and a few clouds. Where do you start?

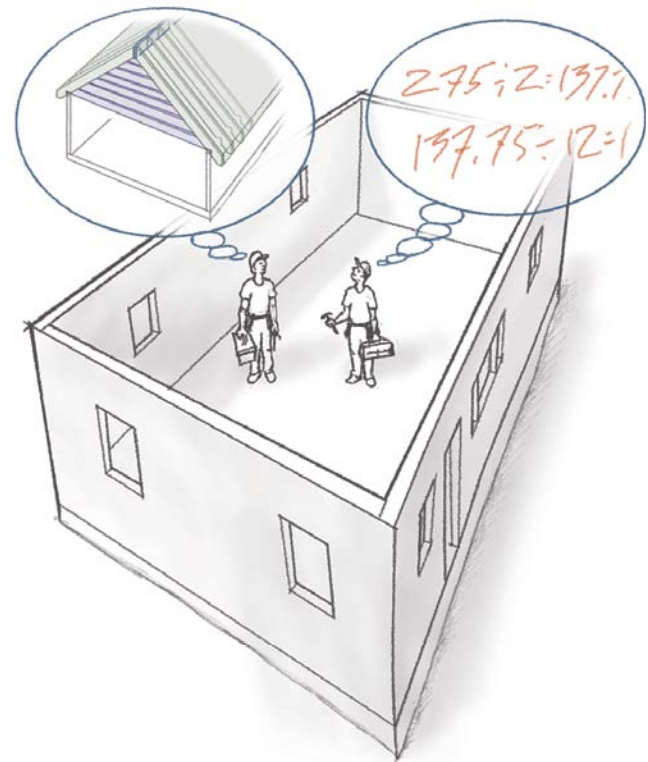

Expanding and Contracting Triangles

You can expand the size of any triangle—without altering its angles—by simply multiplying the lengths of all three sides by the same number. This process works in the other direction, too. You can shrink the size of any triangle—without changing its angles—by dividing the lengths of all three sides by the same number. Since the math involved in most roof framing boils down to the making of a large triangle out of a small triangle, you can usually do all the calculations necessary by using simple math (addition, subtraction, division, and multiplication).

Expanded angles remain the same.

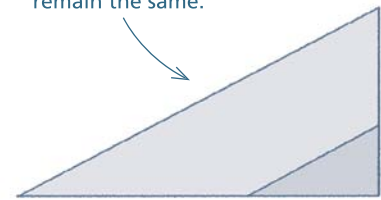

The Difference between Math and Layout

Math alone cannot lay out the parts of a roof frame. Before you do the math, you need to have a clear picture of how that math will fit into the finished structure. You have to know what to measure and you have to do so accurately. Then, after you take the measurements and crunch the numbers, you have to see clearly how to apply that geometry to the lumber in front of you. In roof framing, math is a powerful tool but is the servant of layout.

Layout is an organizational process. To lay out a roof frame, or any other element of a building, you need to visualize and put all the details in their proper place. In addition to keeping track of all the parts, you have to account for the thickness of those parts and the spaces between them. For this reason, a simple sketch is usually a more effective tool than a calculator.

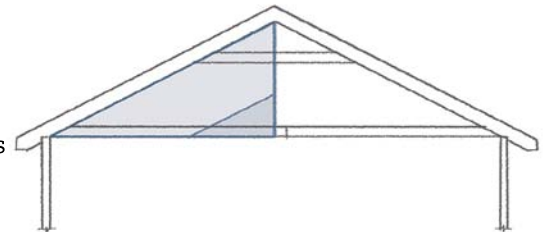

Finding the hypotenuse of the pitch triangle

Because the desired pitch for the sample roof is 6-in-12, you can simply begin with a “pitch triangle” that has a 6-in. altitude and a 12-in. base. You can use a calculator to determine the hypotenuse of this triangle, which is 13.42 in. (rounded). Another route to the same number is to look at the first line in the rafter tables on a traditional rafter square. If you look under the number 6, the first entry is 13.42. Keep in mind, though, that using a rafter square introduces minor rounding errors because multipliers only extend two decimal points. A calculator is more precise.

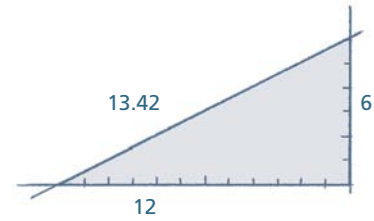

Finding the dimensions of the measuring triangle

Once you know the hypotenuse of the pitch triangle, all you have to do is to expand it into a large “measuring triangle,” which establishes the exact height for the ridge and provides you with the critical dimensions for the rafter layout. The math is easy; simply multiply 6, 12, and 13.42 by the same number. The difficult part is discovering what that number, or multiplier, is.

You can find the correct multiplier and the dimensions of the measuring triangle by going through a simple three-step process. A simple sketch can be helpful for this, especially the first couple of times you do it.

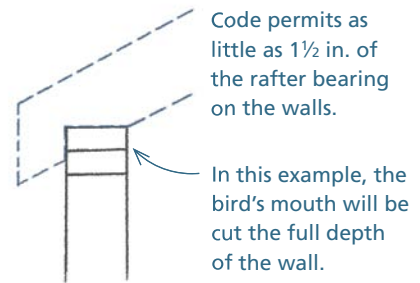

● STEP 1: FIND THE BASE OF THE MEASURING TRIANGLE

Measure the distance in inches between the exterior bearing walls (**A**), 277 in. (23 ft. 1 in.).

Subtract the ridge thickness (**B**) (1.5 in.).

Divide the remainder in half (**C**)
($277 - 1.5 = 275.5$; $275.5 \div 2 = 137.75$).

The base of the measuring triangle is 137.75 in.

● STEP 2: DIVIDE THE BASE BY 12

To create a triangle that has 137.75 as a base and has the exact same pitch and angles as the small pitch triangle, you need to find the multiplier.

Divide 137.75 by 12.

The result, 11.479, is the multiplier you need.

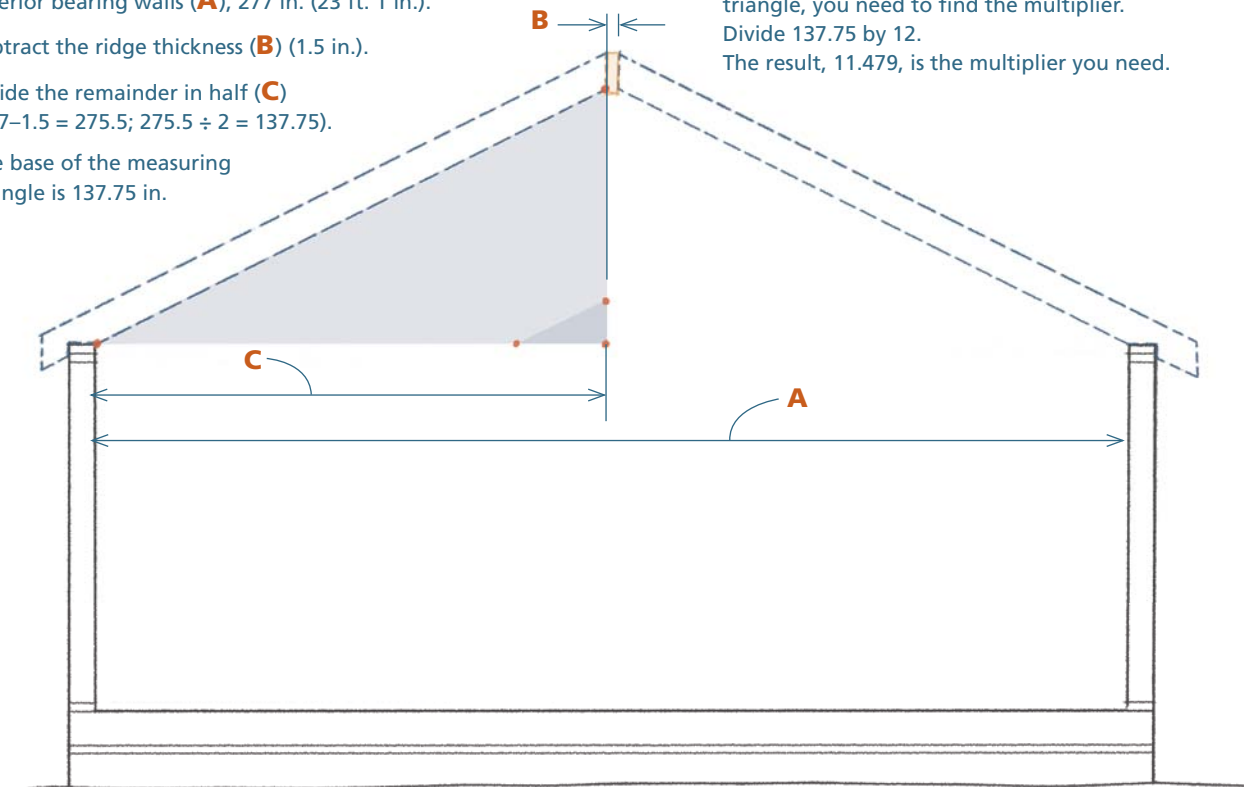

● STEP 3: EXPAND THE PITCH TRIANGLE BY THE MULTIPLIER

Multiplying 6, 12, and 13.42 by 11.479 gives you the three sides of the measuring triangle.

The hypotenuse, 154.048 in. ($154\frac{1}{16}$ in.), is the distance between the short point of the top, plumb cut of the rafter, and the short point of the level cut of the bird's mouth at the bottom.

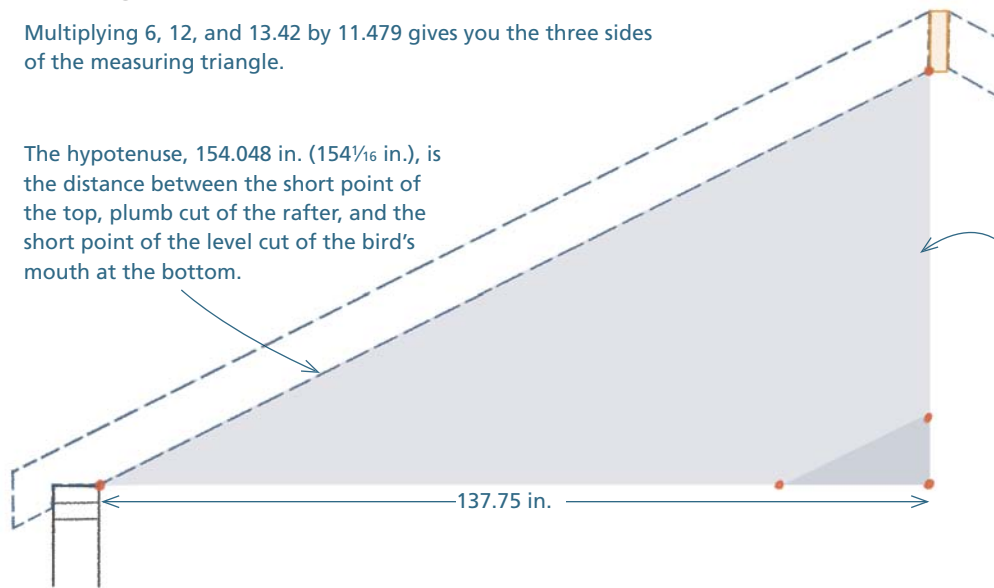

The altitude of the measuring triangle, 68.874 in. ($68\frac{7}{8}$ in.), is the distance to the bottom of the ridge. (The ridge has been ripped to match the height of the plumb cut of the rafter.)

WAYS OF WORKING

Using Base-1 Triangles

You can simplify the math by shrinking the base-12 pitch triangle to a base-1 triangle. Divide 6, 12, and 13.42 by 12; the result is a triangle with a base of 1, an altitude of 0.5, and a hypotenuse of 1.118. Now expand this tiny pitch triangle by a factor of 137.75, which is the base of the measuring triangle you want to create. Of course, $1 \times 137.75 = 137.75$; $0.5 \times 137.75 = 68.875$; and $1.118 \times 137.75 = 154$. (For a table of base-1 numbers, see "Base-1 Proportions of Standard Roof Pitches" on p. 501.)

Once you find the "run" of the rafter (i.e., the base of the measuring triangle), you can use that dimension with these numbers to determine both the height of the ridge and the key dimensions of the rafter for any whole number pitch from a 3:12 to an 18:12. As you'll see later in this chapter, using base-1 numbers can really simplify matters when you get into more complex roofs and when you frame walls and other elements that have to follow the pitch of the roof.

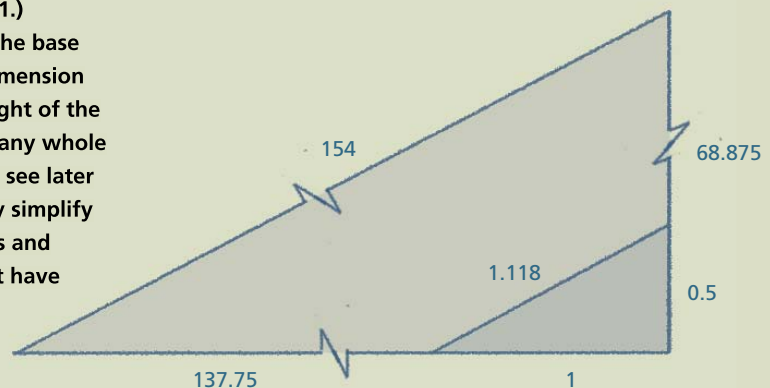
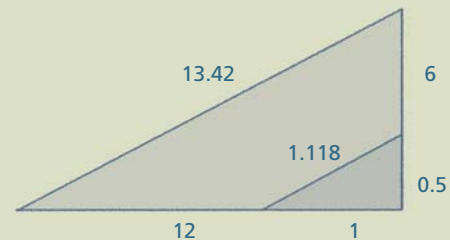

Make a Rafter Jig

There are several special-purpose squares on the market for laying out the plumb and level cuts on rafters. Among these are a traditional rafter square, a Swanson® Speed Square, a Stanley® Quick Square®, and a C.H. Hanson® Pivot Square™. If you choose to use any of these tools, read the manual to see how to use it to lay out the cuts.

Another way to lay out plumb and level cuts is to make a rafter jig. Because it is a simple and easy-to-use tool, the rafter jig will be used to describe the layout of stick-built roofs in this chapter. You can make a rafter jig in 5 to 10 minutes out of three scraps of wood.

Start with a scrap of plywood; for the roof here, you'd need one about 15 in. by 30 in. You need a crisp right angle for the jig, so look for a scrap with a factory-cut corner.

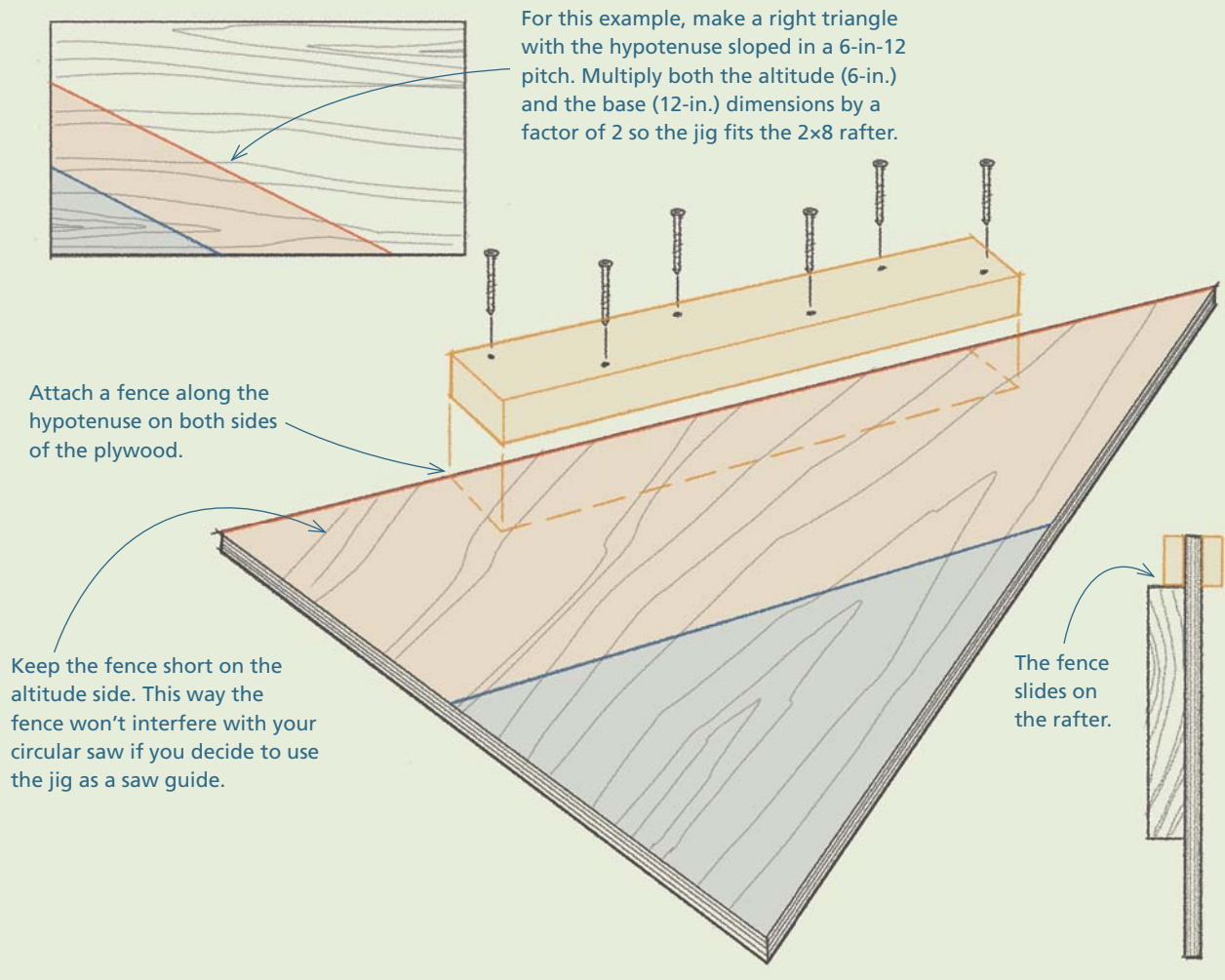

Lay Out, Cut, and Assemble the Gable Roof

With the locations of the rafters and joists marked on the walls and the ceiling joists in place, set planking across the joists and use this platform to stand on as you install the ridge and the upper ends of the rafters.

STEP 1 Rip the ridge

There are two ways to use the altitude of the measuring triangle, $68\frac{7}{8}$ in., to set the ridge at the right height. Both methods rely on finding the length of the top cut. The ridge in Method One will be used on the following steps.

● FIND THE PLUMB CUT LENGTH

The measured length of the plumb cut is $8\frac{1}{8}$ in.

Use a rafter square set to 6 and 12 to scribe a plumb line on a piece of the 2x8 rafter material.

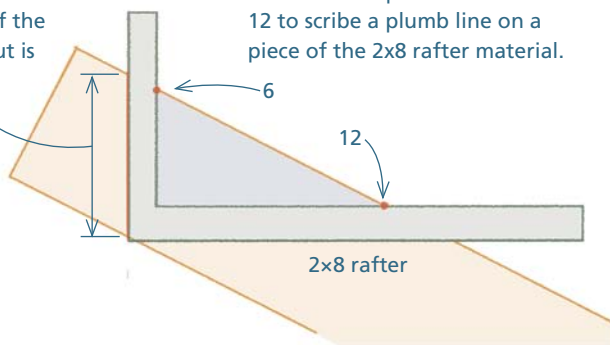

● METHOD ONE

Rip a 2x10 to the $8\frac{1}{8}$ -in. length of the top cut.

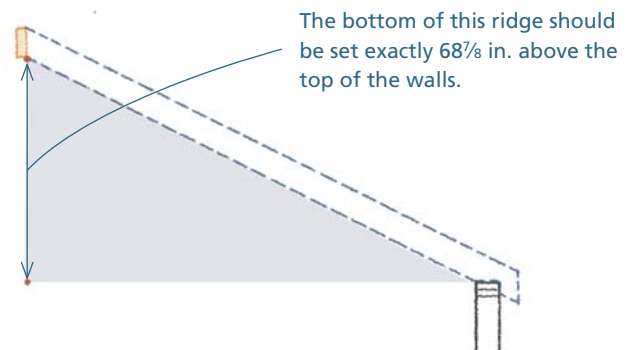
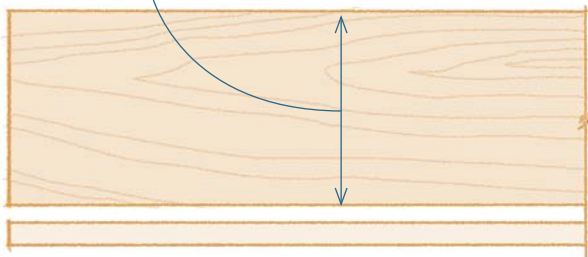

● METHOD TWO

To use a full 2x10, mark $8\frac{1}{8}$ in. from one edge of the 2x10.

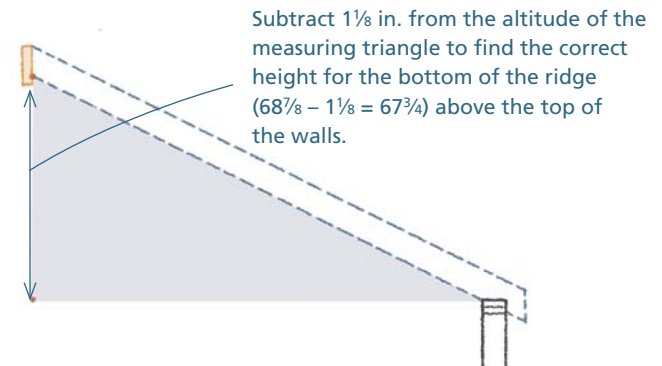
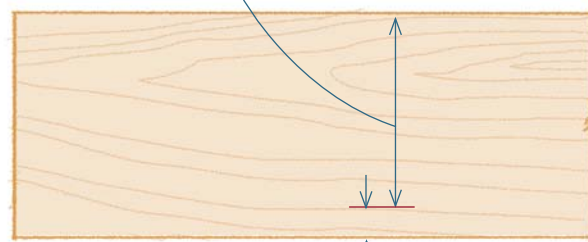

STEP 2 Use posts to hold the ridge at the correct height

Set the ridge pieces in place on top of the blocks, and screw them to the sides of the posts. Over the length of the house, you would probably need to use three or four pieces of lumber for the entire ridge.

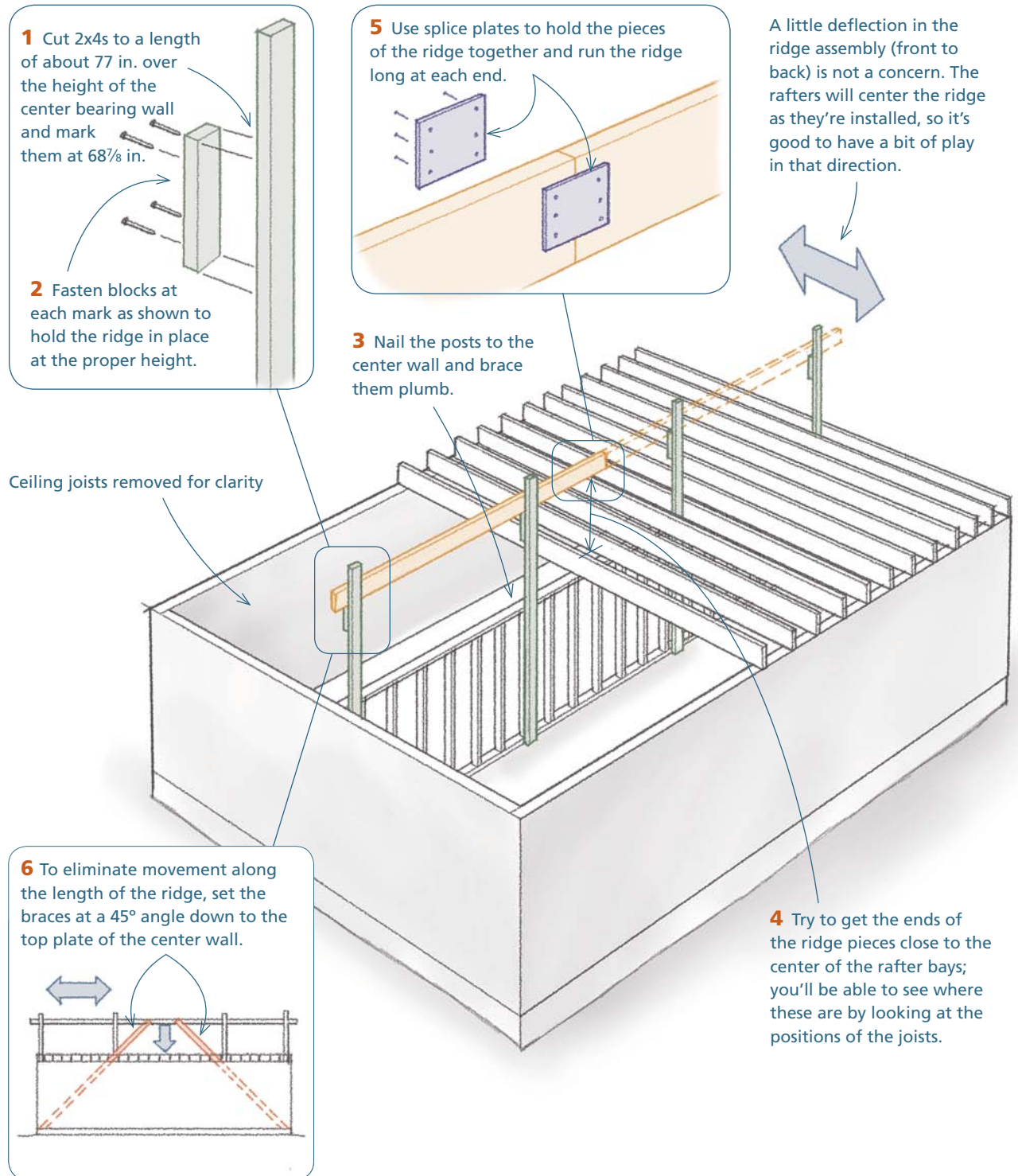

STEP 3 Lay out the rafter locations on the ridge

- 1** Use a 6-ft. level or other device to transfer the locations of the ends of the house up to the ridge.
 - 2** Lay out the rafter locations on the ridge; the layout must match and be pulled from the same end of the house as the rafter locations on the wall.
 - 3** Before beginning the rafter installation, cut the ridge to length at the two marks that represent the end of the house (or trim them to fit into a planned overhanging rake).
- Ceiling joists removed for clarity

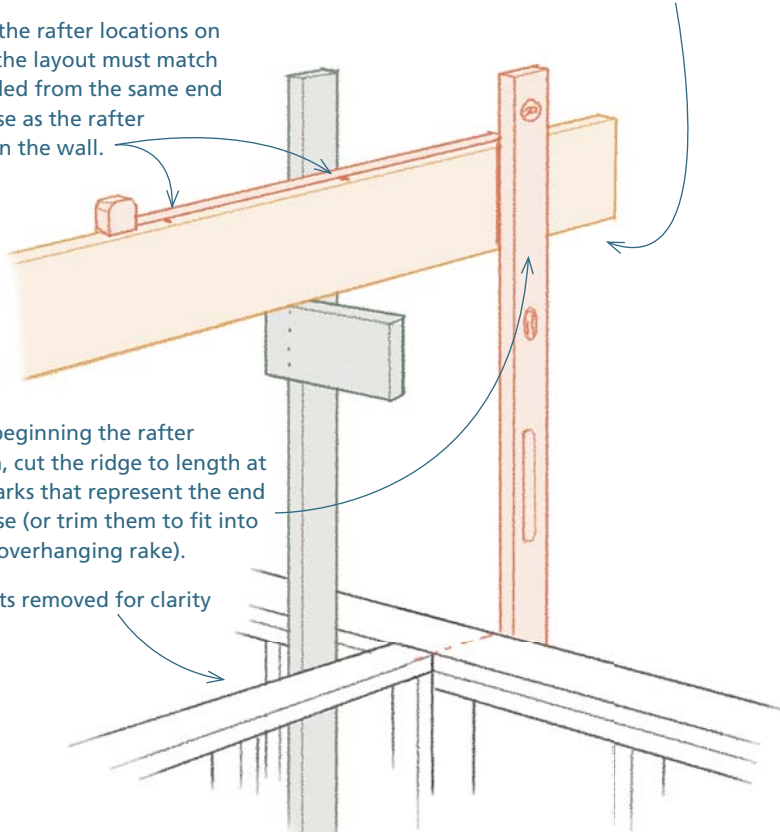

SAFETY FIRST

Secure the Planks

.....
 When you place planking temporarily across the joists, always screw it in place. Unsecured planking can move as you work. When it works its way short of the outside joist, it can tip down when you step on it and send you on an unpleasant ride.

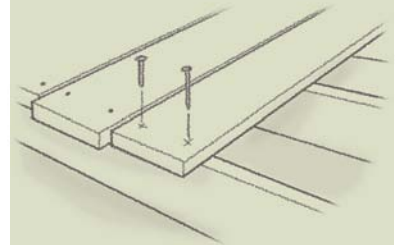

STEP 4 Lay out and cut the rafters

• **LOCATE THE MEASURING TRIANGLE**

- 1** Crown the rafter material as explained in chapter 2 (see p. 61).
- 2** Hold the rafter jig against the top edge of the rafter material and scribe the top plumb cut line.
- 3** To locate the bird's-mouth level line (**B**), measure and mark a distance equal to the hypotenuse of the measuring triangle ($15\frac{4}{16}$, in this case) from the short point of the top plumb cut (**A**).

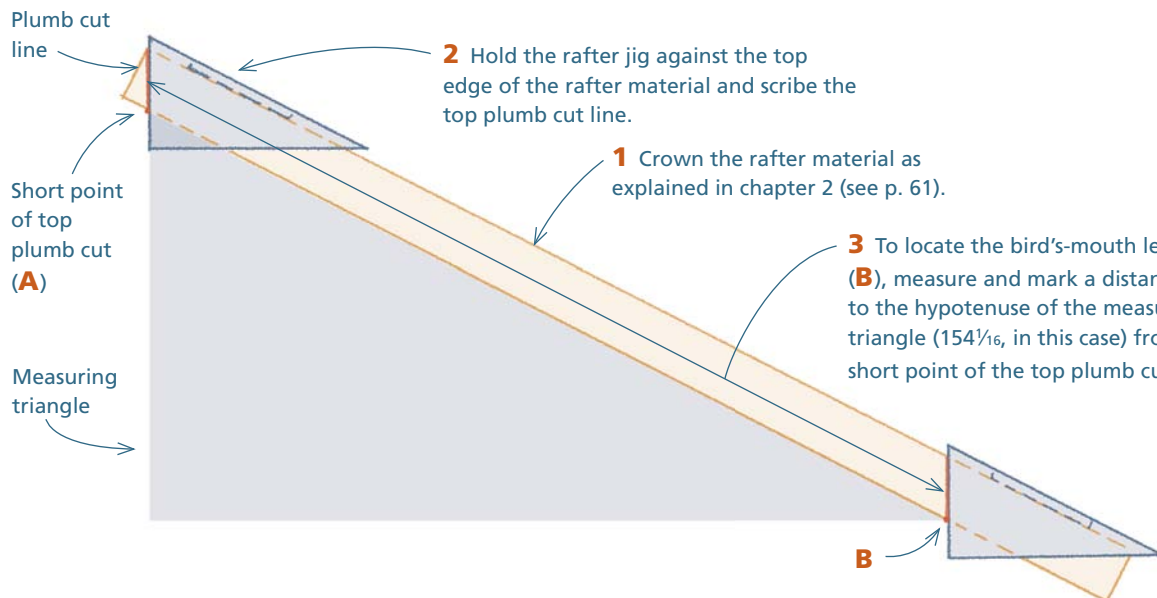

STEP 5 Lay out and cut the bird's mouth

1 At the bird's mouth (**B**), use the rafter jig to lay out a level line.

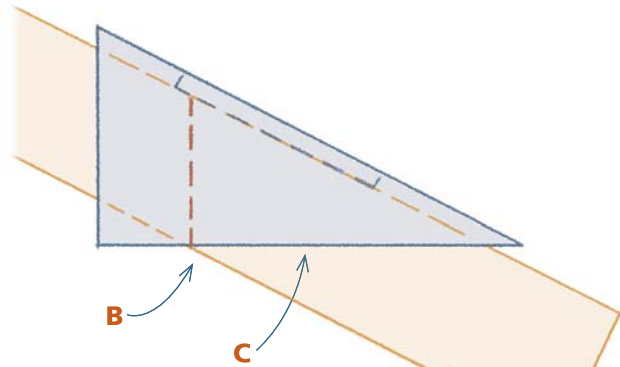

2 From **B**, measure along a level line equal to the exterior wall (6 in.), plus about $\frac{3}{8}$ in. (**C**) (to allow for slight variations in the wall).

3 Slide the jig down until the plumb edge lines up with the mark, and scribe a plumb line to finish the bird's-mouth layout.

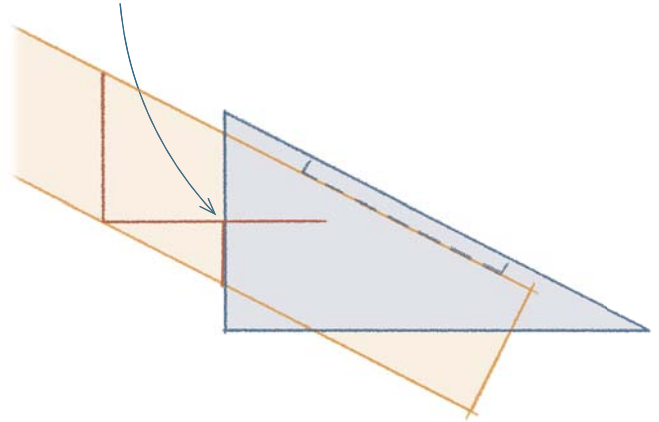

JIGS & FIXTURES

Making a Story Stick

After laying out and cutting the first rafter, many carpenters use it as a pattern to lay out the rest of the rafters. This works fine, but lifting and tracing the pattern rafter dozens of times is a bit strenuous. On larger roofs, you can avoid this work by measuring with a tape measure and a story stick rather than a 16-ft.-long 2x8.

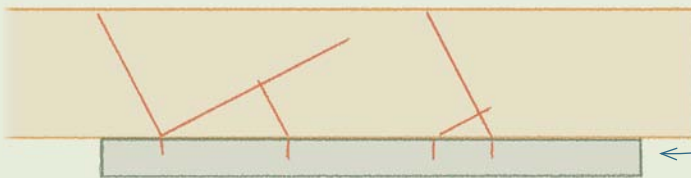

1 Place a short strip of wood along the bottom of the first rafter below the four lines that represent the bird's mouth and rafter tail layouts. Transfer the points where these lines meet the edge of the board to the strip of wood.

2 For subsequent rafters, make the top cut with the rafter jig.

3 Use a tape to take the long measurement to the bird's mouth.

5 Use the rafter jig to draw the four lines of the bird's mouth and rafter tail layouts.

4 Use the story stick to transfer the three other marks to the bottom side of the rafter.

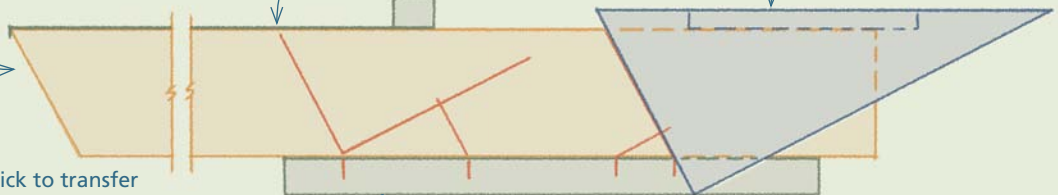

STEP 6 Lay out the rafter tail

The rafter tail is the section of the rafter that extends beyond the outside of the exterior wall and forms the upper side of the eave.

At this point, you've completed the layout for the main section of the rafter. You could cut the bird's mouth and begin installing the rafters, leaving the rafter tails for later. Alternatively, you can lay out and cut the tails while the rafters are still on the ground.

● CUT BEFORE INSTALLING

In this example, the framed eave should end 12 in. beyond the framed wall. Part of the framed eave will consist of a fascia that's 1½ in. thick; therefore, the end of the rafter tail needs to be 10½ in. out from the face of the exterior wall. Because the wall is 6 in. thick, the end of the rafter should be 16½ in. out from the inside of the wall.

The 16½-in. dimension runs along a level line, so you can use it as the base of a second measuring triangle.

The hypotenuse of this triangle will be the distance from the first (154¹/₁₆ in., **B**) mark to the end of the rafter. Here's a good opportunity to use the base-1 numbers, which, hopefully, you've written right on your rafter jig.

● LEAVE THE TAILS LONG

In this example, the rafter tails will be left long and cut after the rafters are installed.

Calculate the amount of rafter material you'll need beyond the outside of the wall.

To find the distance from **B** to the end of the rafter tail, multiply 16.5 x 1.118 = 18.447 (18⁷/₁₆ in.).

Measure and mark this distance along the bottom edge of the rafter from the 154¹/₁₆ in. mark. Use the plumb edge of the rafter jig to mark the end of the rafter tail.

The undersides of the rafter tails may need to be cut along a level line. Measure and mark the desired distance from the top of the plumb cut, slide the rafter jig to that mark, and scribe along the level edge.

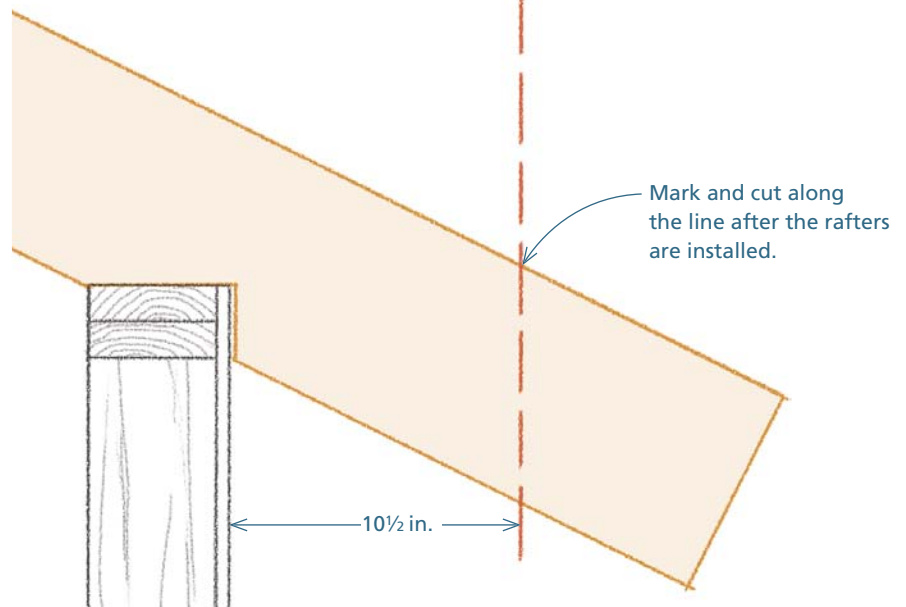
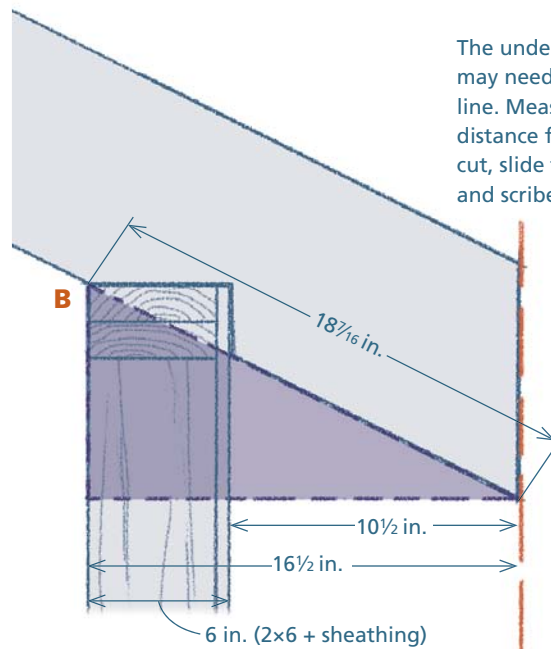

Installing Rafters

Installing the rafters is straightforward. Although not essential, you can clamp or screw a “thrust block” at the heel of the bird’s-mouth cut; this helps hold and align the rafter as you install it.

A thrust block is particularly effective if you’re working alone or in a small crew.

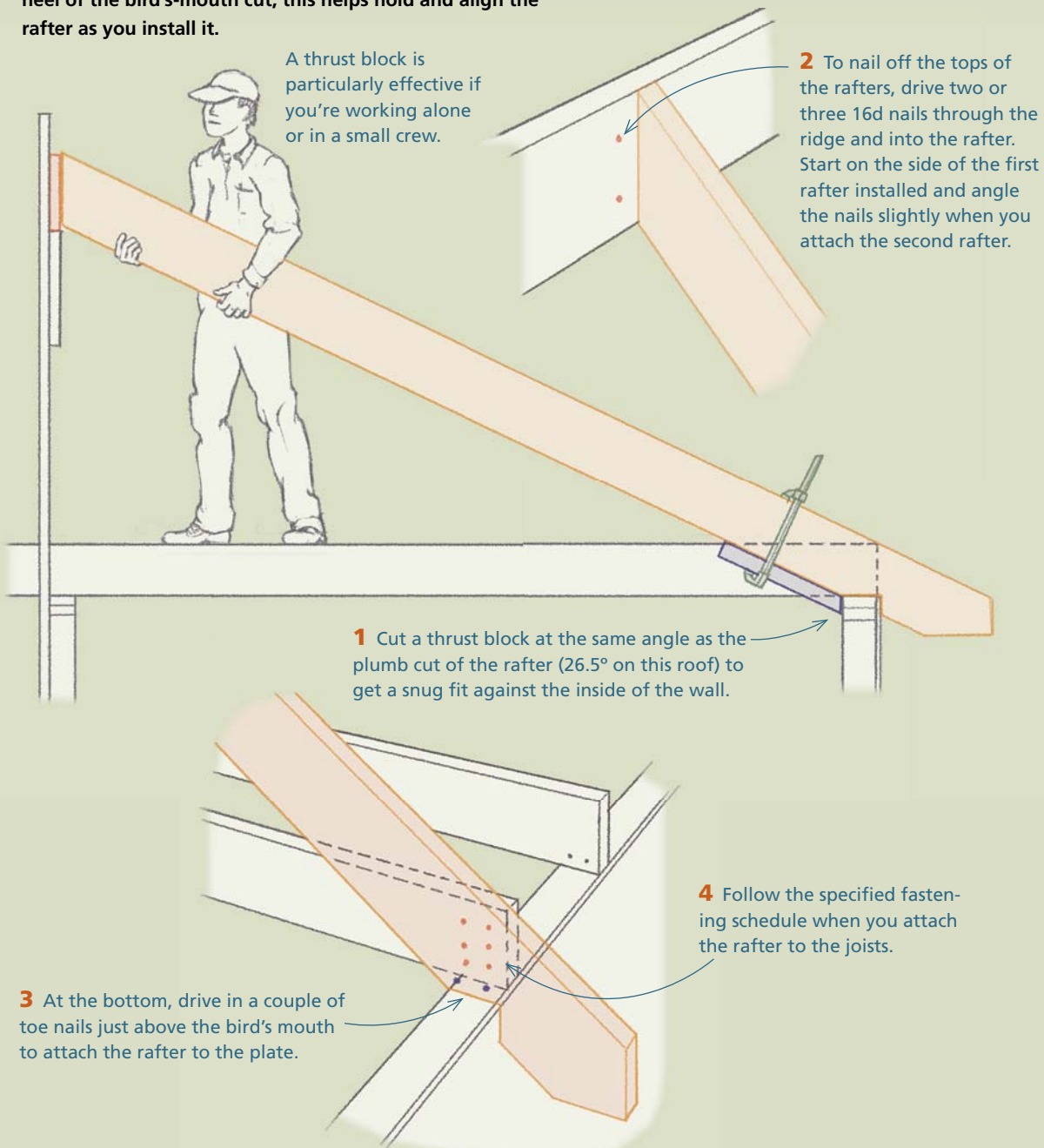

Building a Hip Roof

In this example, the building is 16 ft. wide and 24 ft. long (not including the thickness of the sheathing). The 2x6 walls are braced, but the ceiling is not yet installed. The plan calls for a 7-in-12 hip roof with 16-in. rough eaves.

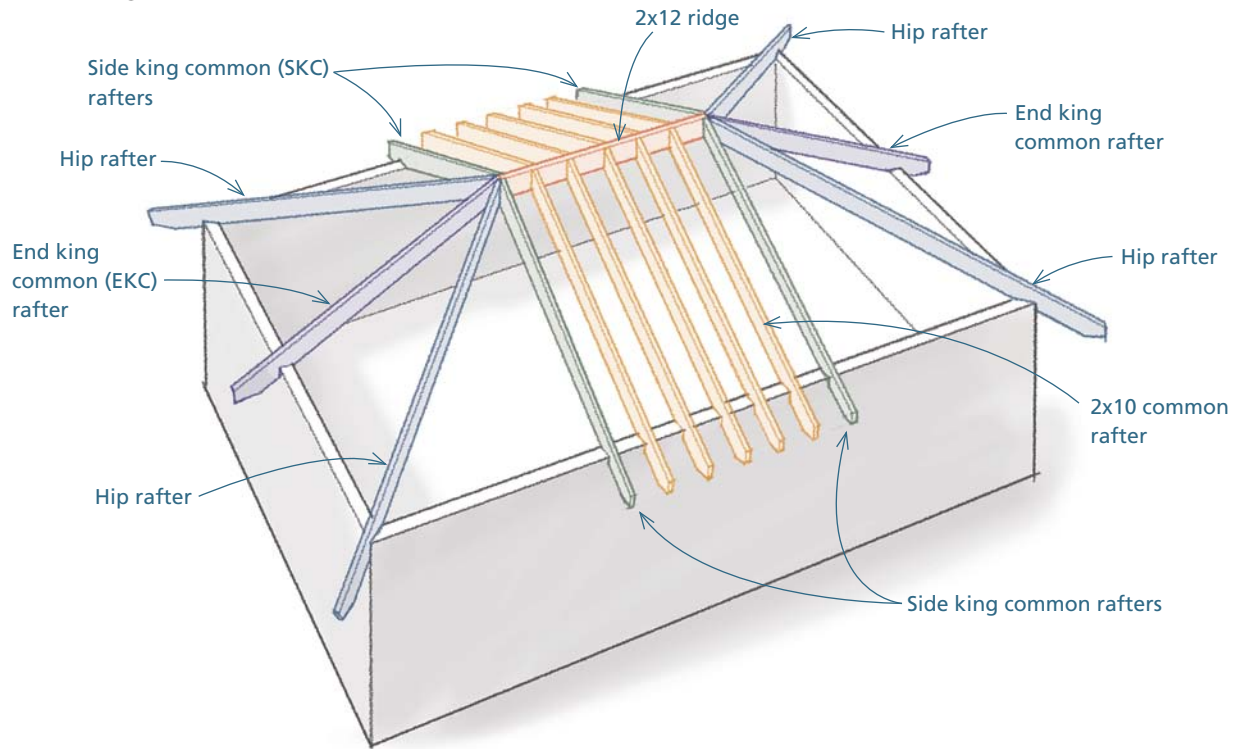

King Common Rafters

The king common rafters are exactly the same as the rest of the common rafters; the name is used to indicate where they are placed in the roof frame.

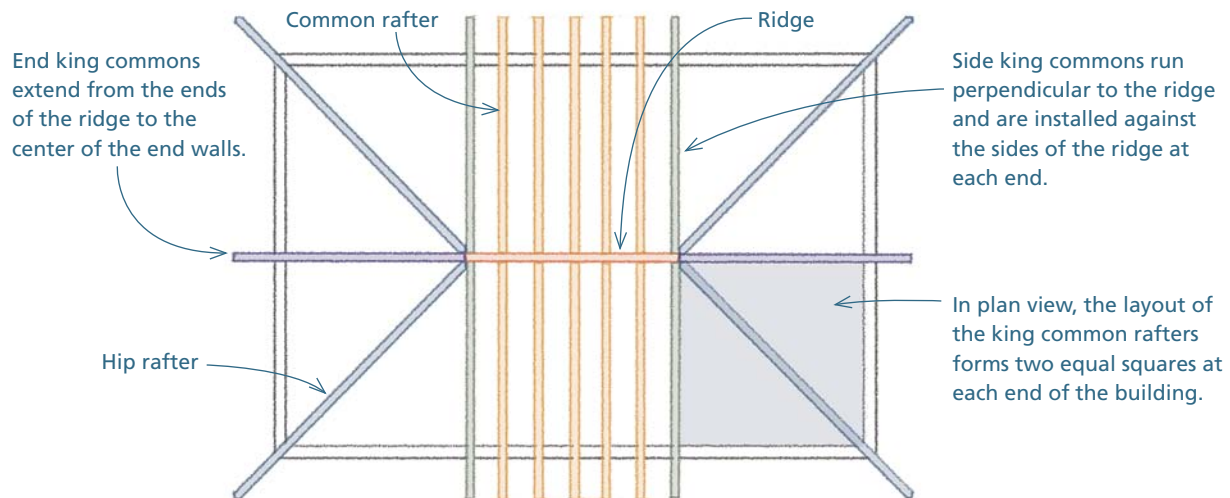

STEP 1 Lay out the king common rafter locations on the walls

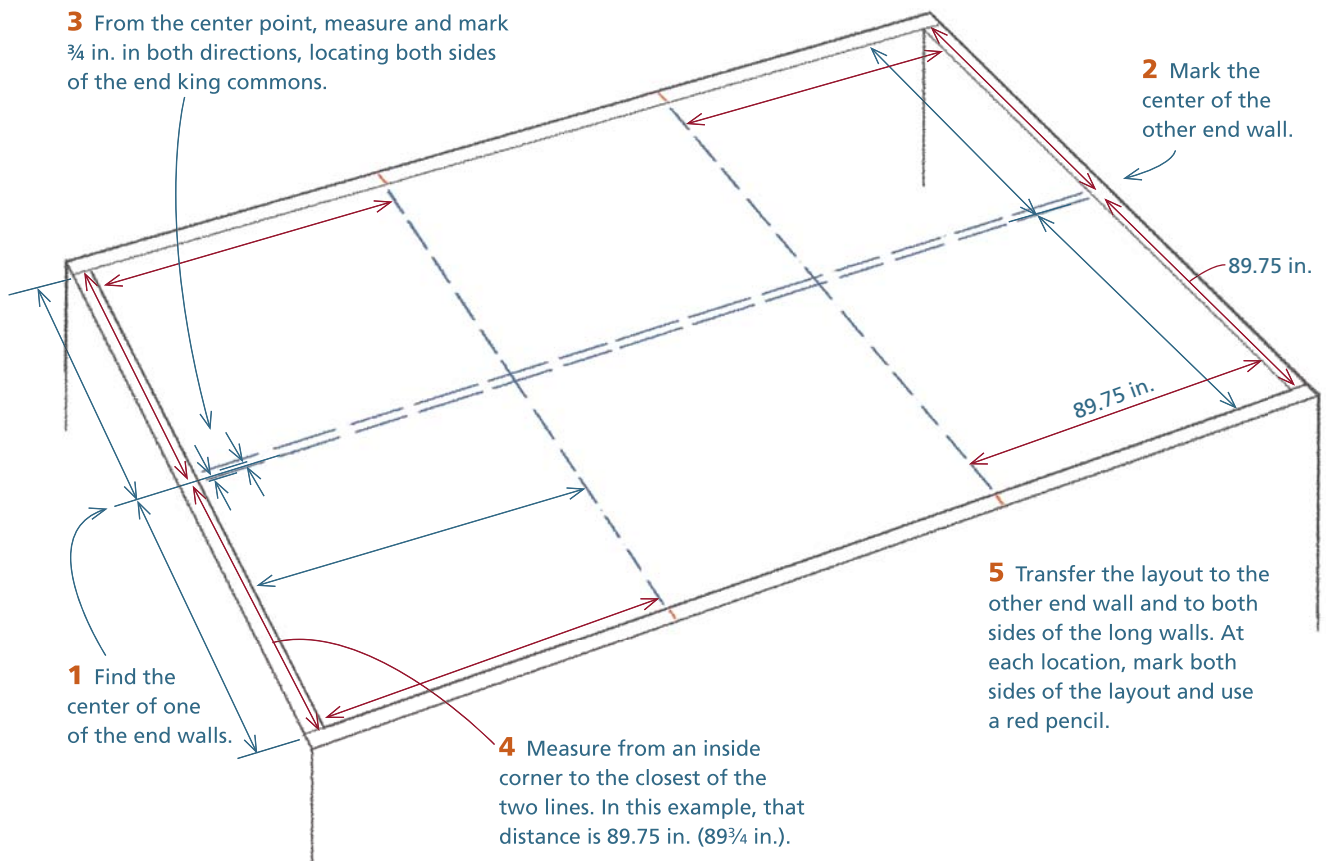

STEP 2 Lay out the hip rafter locations

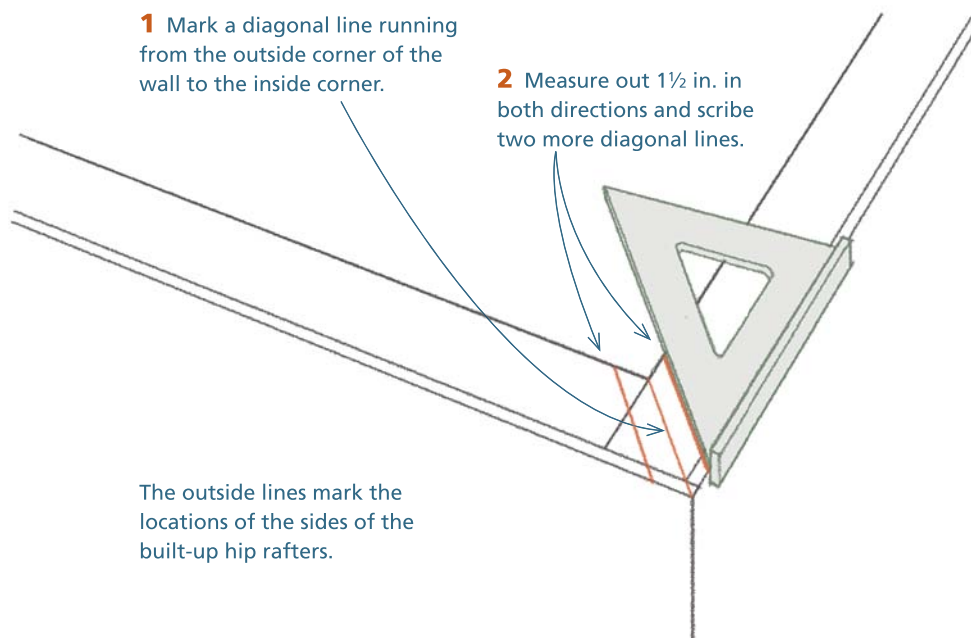

STEP 3 Lay out the jack and common rafter locations on the long walls

The jack rafters extend from the tops of the walls to the hip rafters. On the long walls, they are located in the areas between the side king common rafters and the corner of the building. The common rafters are located in the area between the two side king common rafters, in the midsection of the long walls.

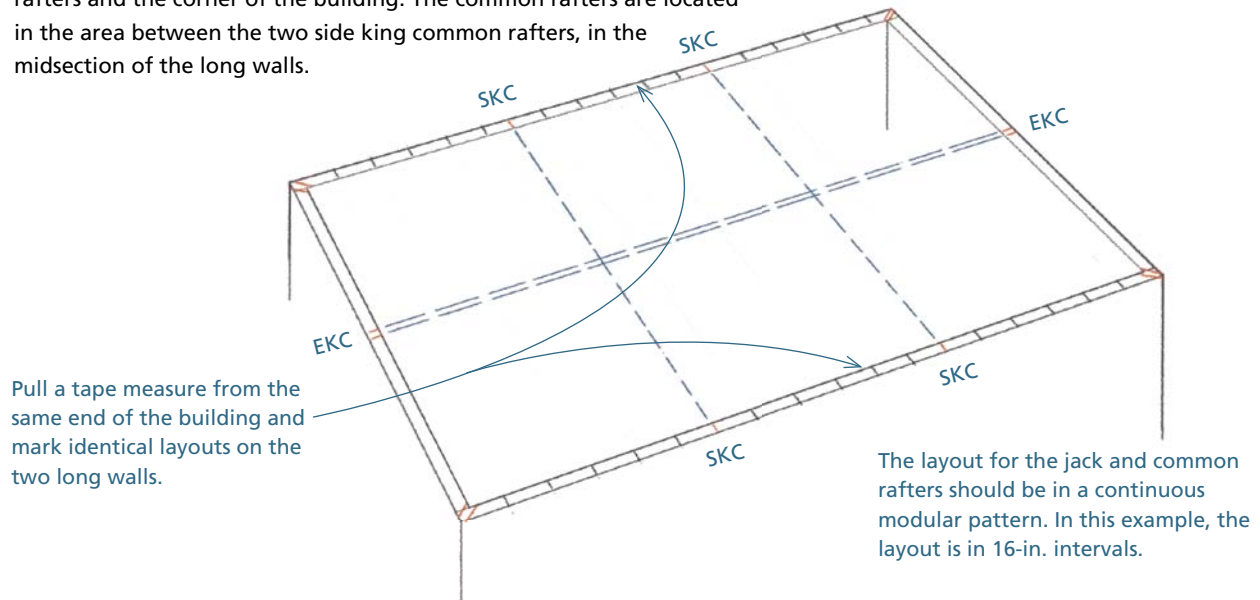

STEP 4 Lay out the jack rafter locations on the end walls

Jack rafter locations for each half of the end walls need to mirror those on the adjacent long wall. This layout ensures that the jack rafters will meet in opposing pairs on the hip rafters.

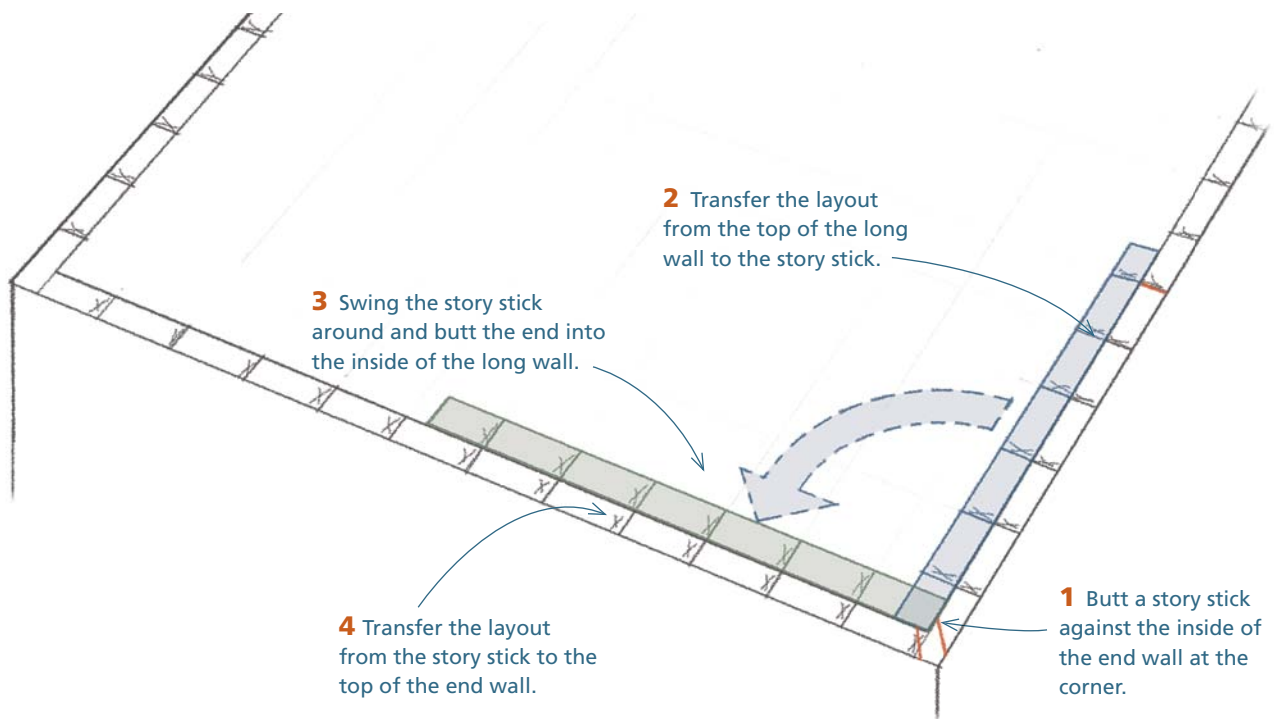

STEP 5 Take key measurements off the top plates of the walls

The key dimensions for the parts of the roof frame can be taken directly from the layout on the tops of the walls. Take these measurements now and record them in your notes.

1 LENGTH OF THE RIDGE

The ridge (97.5 in. on this roof) is equal to the distance between the side king commons, including the thickness of the side king commons.

5 HIP RAFTER SEAT CUT

Use the layout of the hip rafter to measure the length of the seat cut for the bird's mouth. The diagonal line is 8½ in. long.

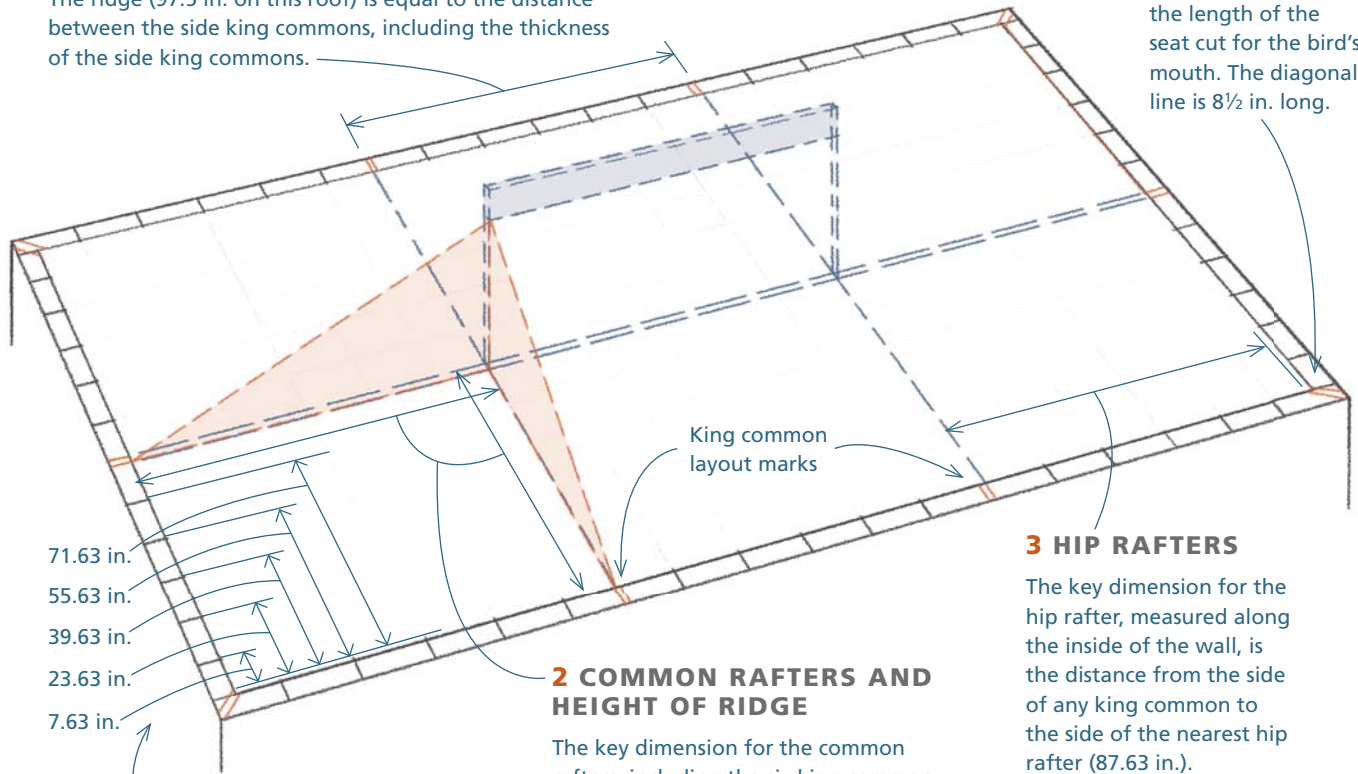

4 JACK RAFTERS

Measure from the side of the hip rafter layout to the jack rafter layout.

2 COMMON RAFTERS AND HEIGHT OF RIDGE

The key dimension for the common rafters, including the six king common rafters, and height of the ridge is the distance from the edge of any king rafter to the corner of the walls (here, 89.75 in.).

3 HIP RAFTERS

The key dimension for the hip rafter, measured along the inside of the wall, is the distance from the side of any king common to the side of the nearest hip rafter (87.63 in.).

STEP 6 Install the ceiling joists

You can install the ceiling joists at any time after you have laid out the rafter locations. In some cases, the ceiling structure serves as a convenient platform to work from as you install the ridge and the rafters. Some carpenters, however, like to install the ceiling joists at the same time that they install the roof structure. To install the ceiling joists, use the procedure discussed in chapter 2 (see p. 94).

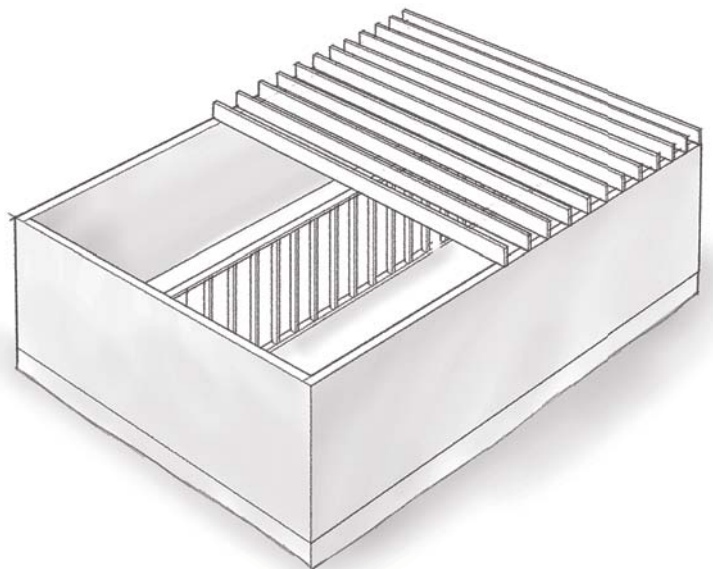

Leave Room for the Rafters at the Ends of the Roof

The procedure for installing the ceiling under a hip roof differs from ceilings installed under other roofs in one detail. You often have to leave out ceiling joists that are within 16 in. of the end walls to leave room for the rafters.

● NO-JOIST ZONE

In this example, the height of the 2x10 joists is $9\frac{1}{4}$ in. (9.25 in.). The base-1 altitude for a 7-in-12 pitch is 0.583 (see p. 501), which means that the underside of the rafters rises 0.583 in. for every 1 in. of horizontal run.

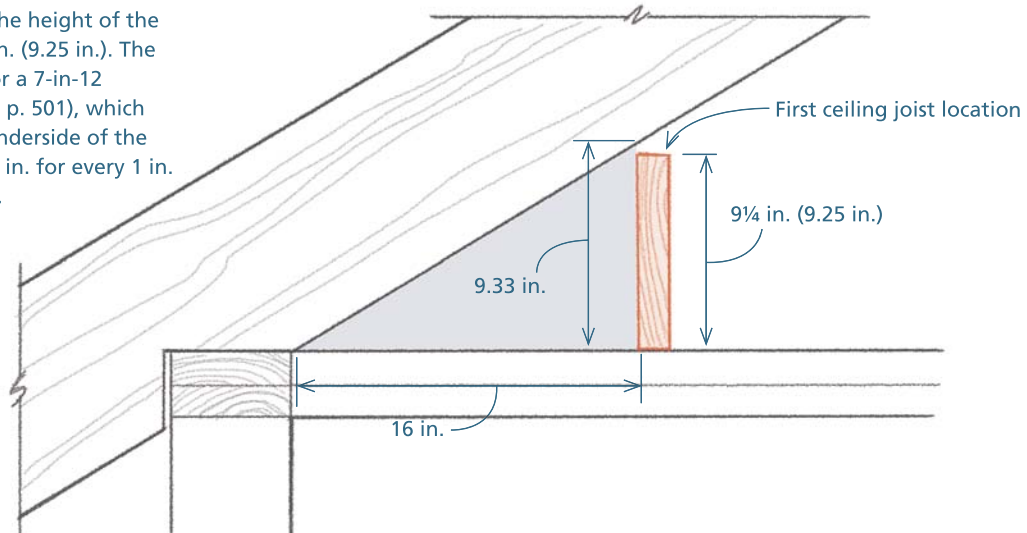

● PROVIDE BACKING FOR THE DRYWALL

Install perpendicular blocks, as explained in chapter 2 on p. 93, to provide a surface for attaching the drywall. Since these blocks have to be nailed from above, it's easier to install them before you sheathe that section of the roof. Make sure not to install them in the locations laid out for rafters.

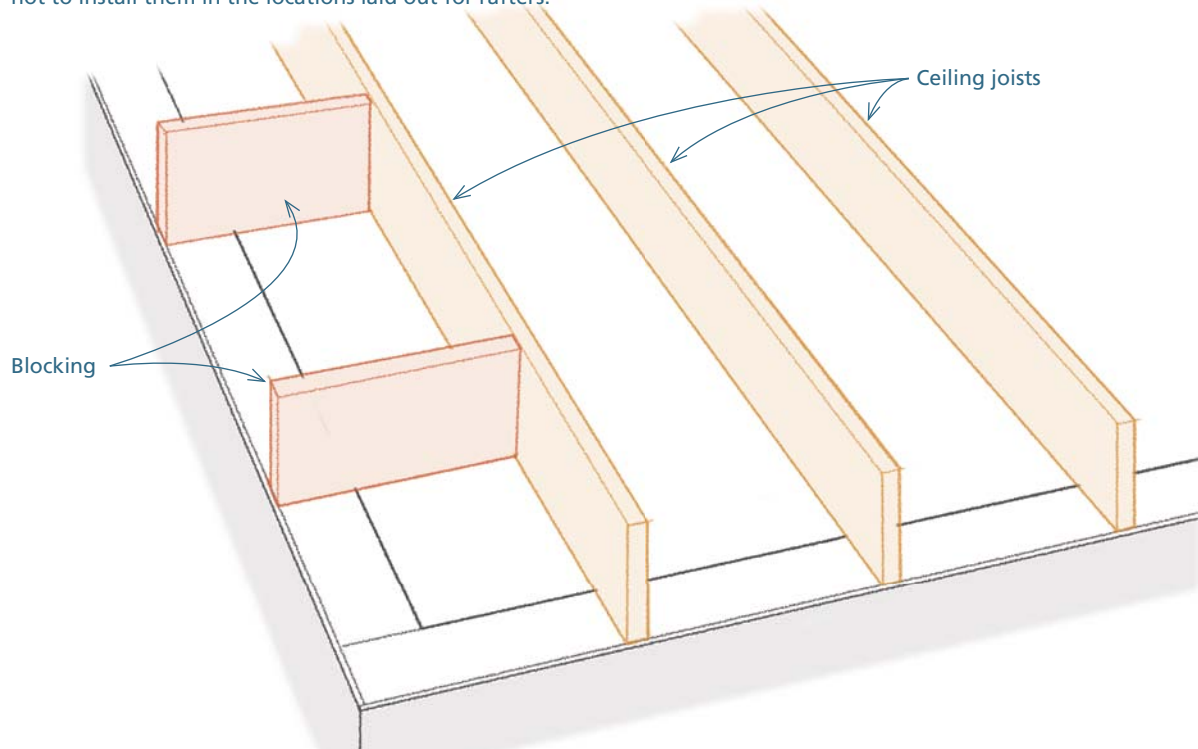

Make Two Rafter Jigs

• COMMON AND JACK RAFTER JIG

For the common and jack rafters, make a 7-in-12 rafter jig following the procedures discussed in "Building a Gable Roof." Look up the base-1 proportions for a 7-in-12 pitch on p. 501.

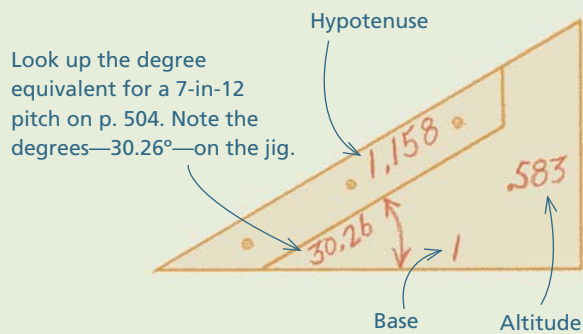

• HIP RAFTER JIG

For the hip rafter, make a 7-in-16.97 jig. Because the hip slashes diagonally across the roof structure (in plan view), the base number of the pitch is $\sqrt{2} \times 12$, or 16.97. Look up the base-1 proportions for a 7-in-16.97 pitch (p. 503) and mark them on the jig.

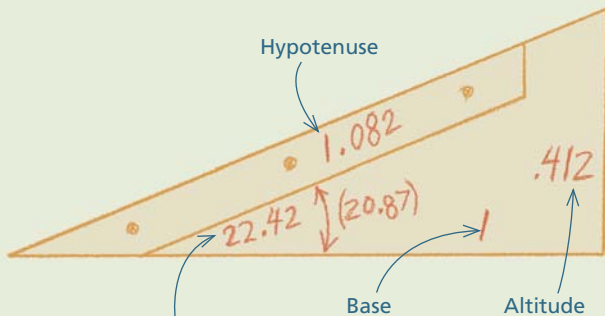

Look up and note the degree equivalent of the pitch (22.42°, p. 505) and the backing angle (20.87°, p. 502) on the jig.

STEP 7 Cut and install the ridge

• MARK THE PLUMB CUT FOR A 7-IN-12 RAFTER

Measure the length of the plumb cut line on a 2x10 rafter. In this example, it is $10\frac{1}{16}$ in.

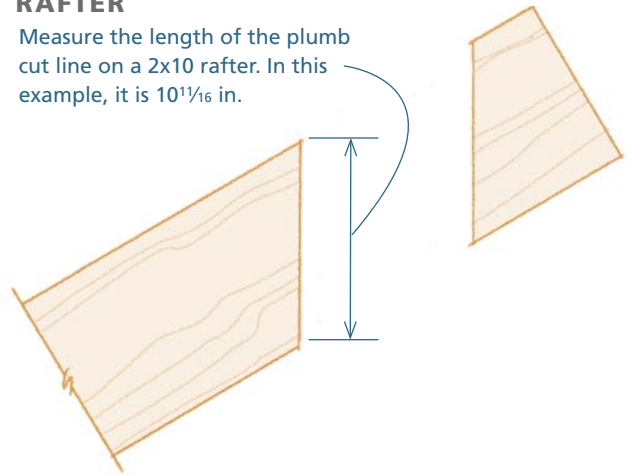

• CUT AND RIP THE RIDGE TO THE LENGTH

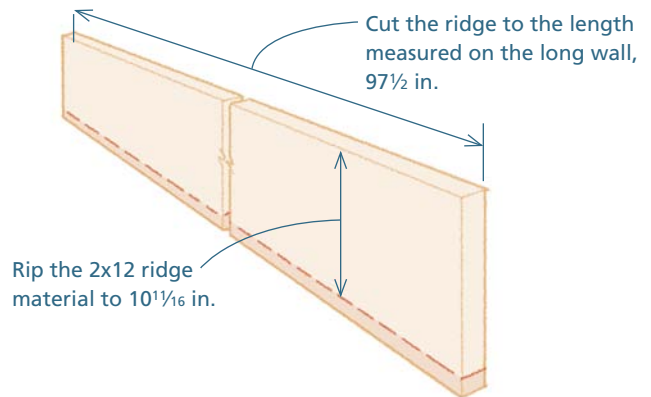

• USE THE KEY DIMENSION (89.75 IN.) TO CALCULATE RIDGE HEIGHT

Multiply the base-1 altitude for a 7-in-12 pitch roof (0.583) by 89.75 to determine the height of the bottom of the ridge ($0.583 \times 89.75 = 52.32$).

Cut posts to temporarily support the ridge at $52\frac{5}{16}$ in. above the top of the walls.

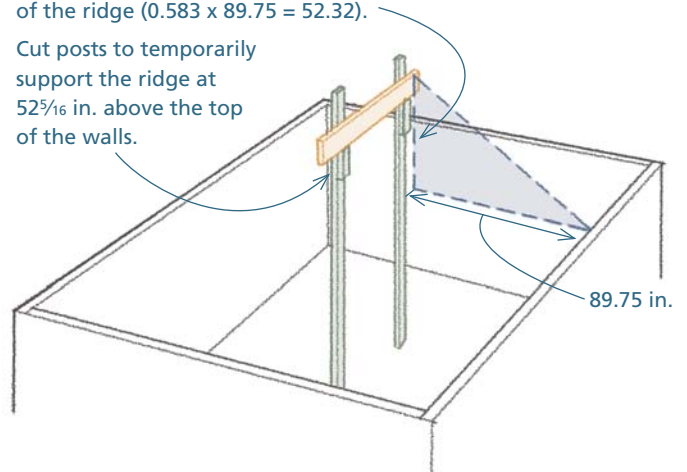

STEP 8 Lay out the common rafters

Use the techniques described in “Building a Gable Roof” to lay out the common rafters. To determine the distance between the short point of the top plumb cut and the short point of the level cut of the bird’s-mouth cut, multiply the base-1 hypotenuse for a 7-in-12 roof (1.158), by 89.75 ($1.158 \times 89.75 = 103.93$). Use the 7-in-12 rafter jig to lay out the common rafters as shown.

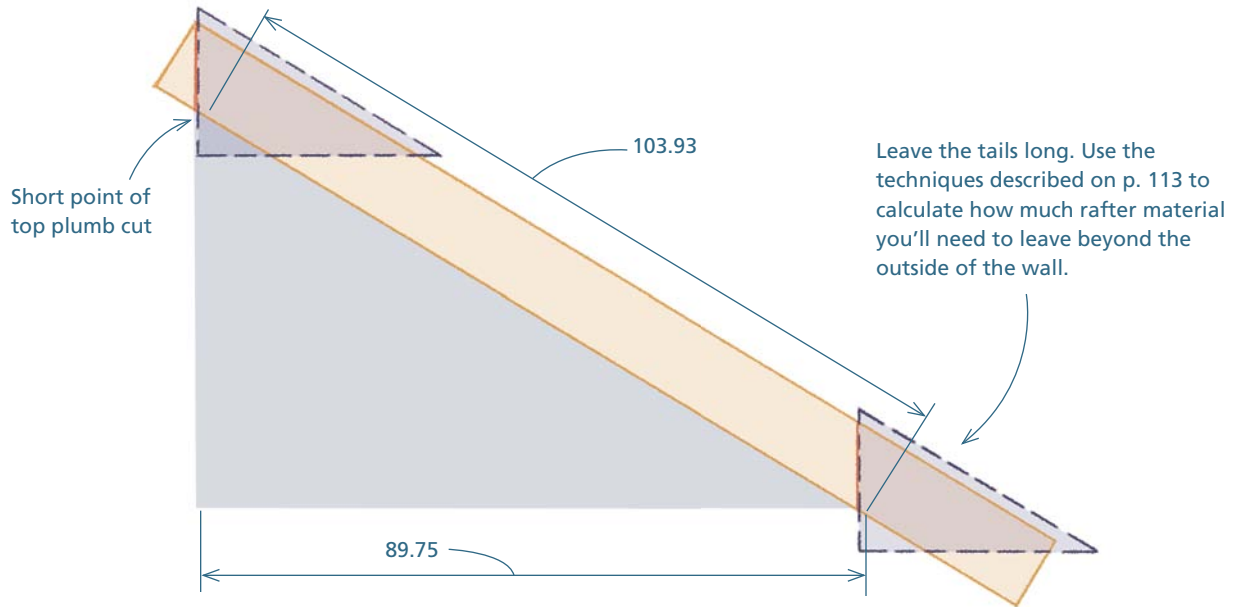

STEP 9 Install the common rafters

Begin by installing the six king common rafters using the techniques discussed in “Building a Gable Roof” on p. 105. Since the king commons are identical, they will center the ridge both between the end walls and the long walls.

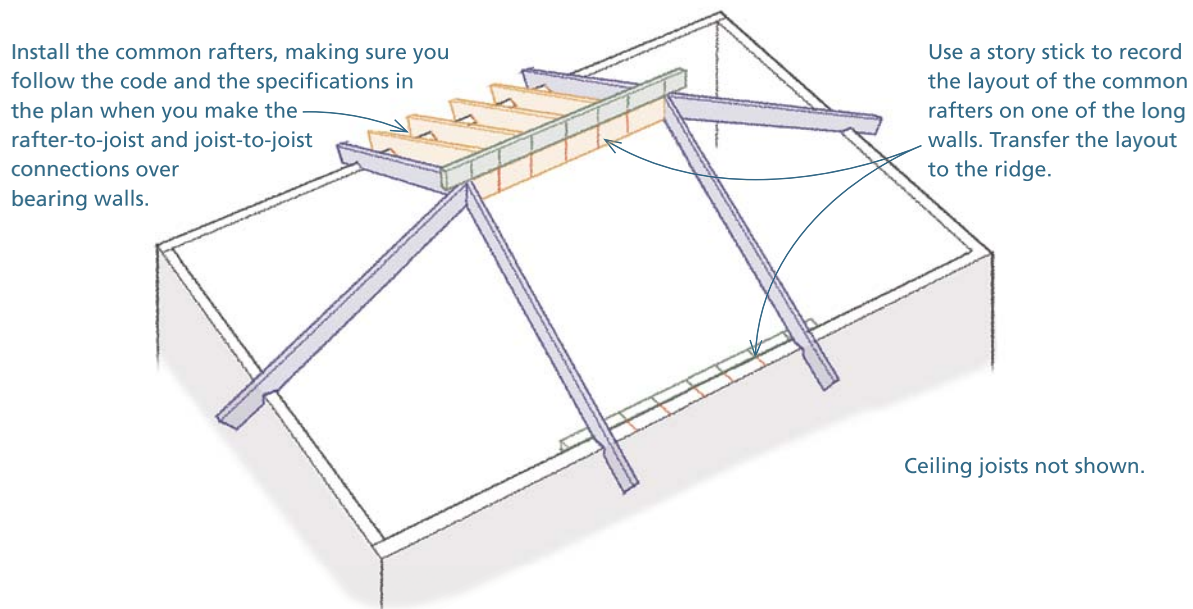

STEP 10 Lay out the hip rafters

The horizontal run of the hip rafter is 1.414 (or $\sqrt{2}$) \times the length of the horizontal run of the common rafters. This is always the case on "regular" hip and valley roofs. A regular roof is when two sections of a roof meet at a right angle and are the same pitch.

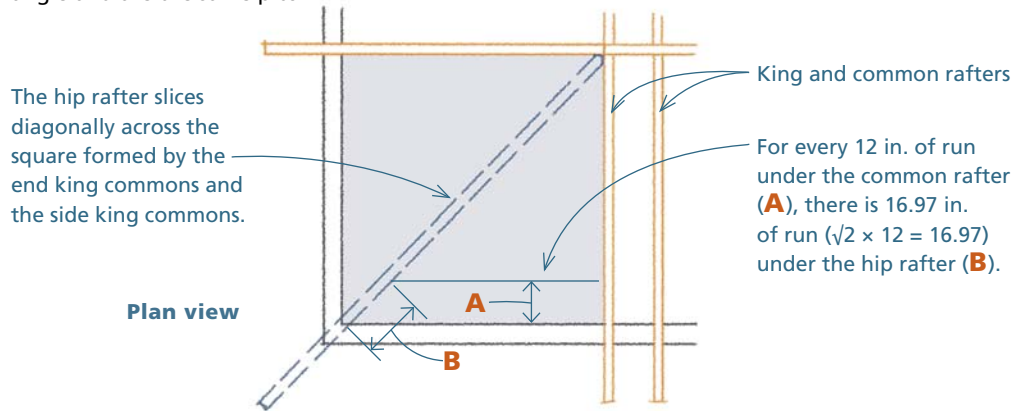

2 Calculate the hypotenuse of the measuring triangle for the hip rafter

Look up the hypotenuse of a base-1 triangle for 7 (C)-in-16.97 (B) on p. 503. Multiply that number, 1.082, by 123.92 to find the hypotenuse: $1.082 \times 123.92 = 134.09$ ($134\frac{1}{16}$ in.).

The pitch of the hip rafter is 7 (C)-in-16.97 (B).

1 Calculate the base of the measuring triangle

The key dimension for the hip, as measured off the top plate, is $87\frac{5}{8}$ or 87.625 in. (D). To find the run along the side of the hip rafter, multiply $\sqrt{2} \times 87.625 = 123.92$ in. This is the base of the measuring triangle for the hip rafter.

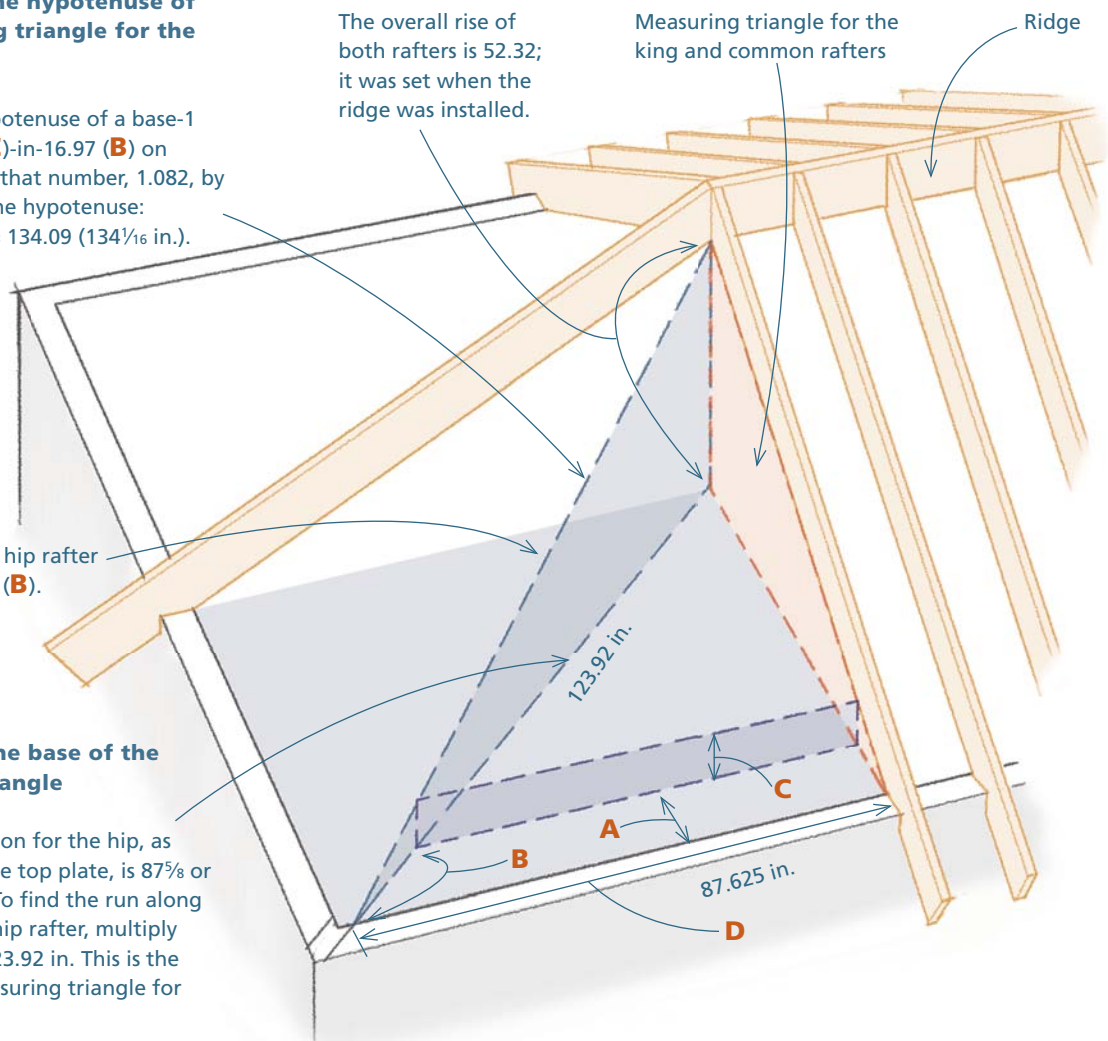

Hip Trouble

When the area under the roof frame is going to remain unfinished, the only thing you have to worry about is lining up the top edges of the hips with the plane formed by the tops of the common rafters. When the area under the roof is going to be finished with a cathedral ceiling, however, the bottom edges of the hips should be in the same place as the bottoms of the common rafters.

The blue area indicates a level plane as it turns the corner of a hip roof.

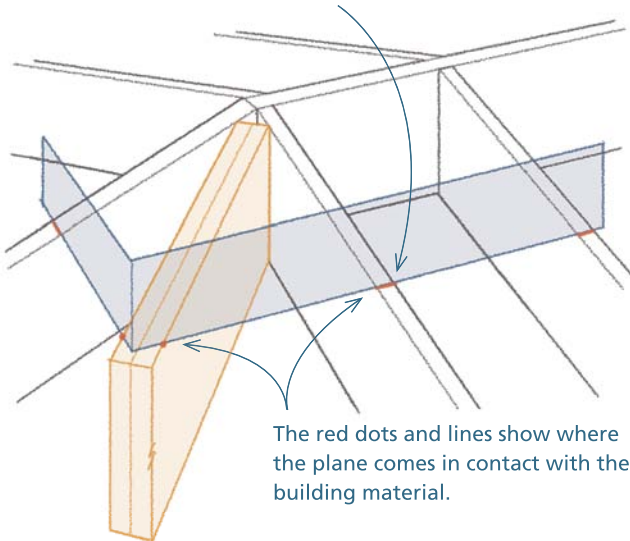

Adding a bevel to the plumb cut allows the material to fit between the king commons.

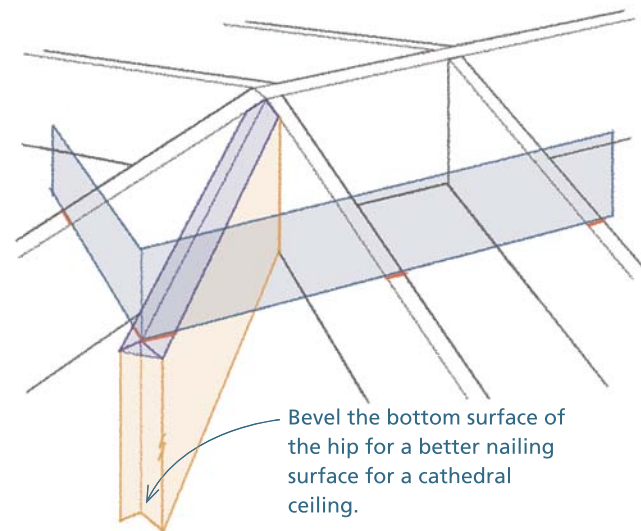
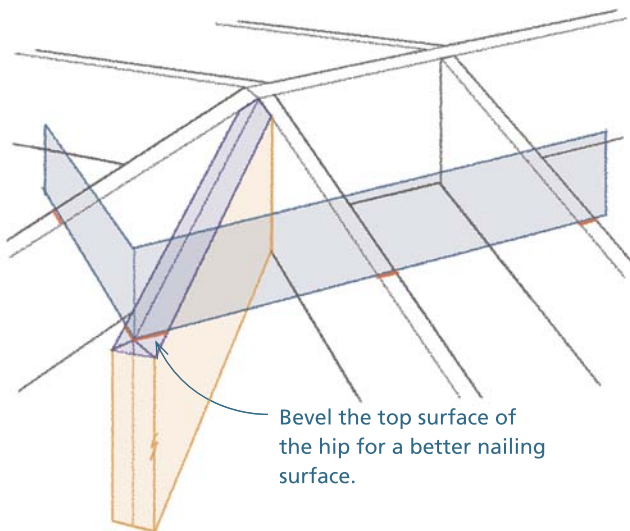
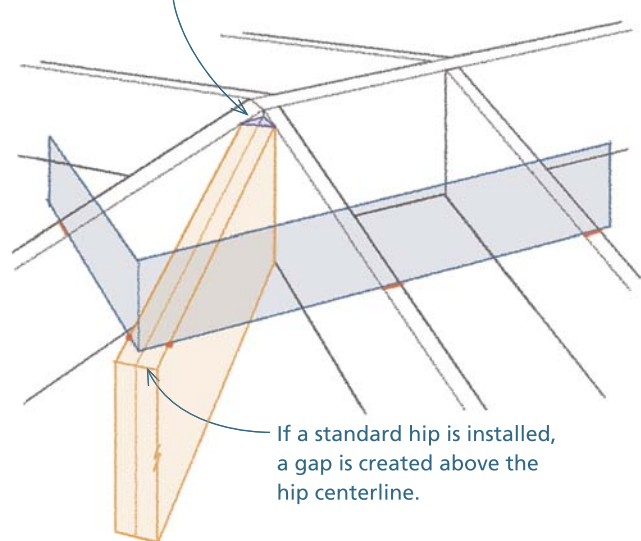

STEP 11 Determine the width to rip the material

Prep the hip material using the techniques described on p. 127. In this example, the plan specifies that the hip rafters should be built up out of two 2×12s and that the bottoms of the hips should end up in plane with the common and jack rafters.

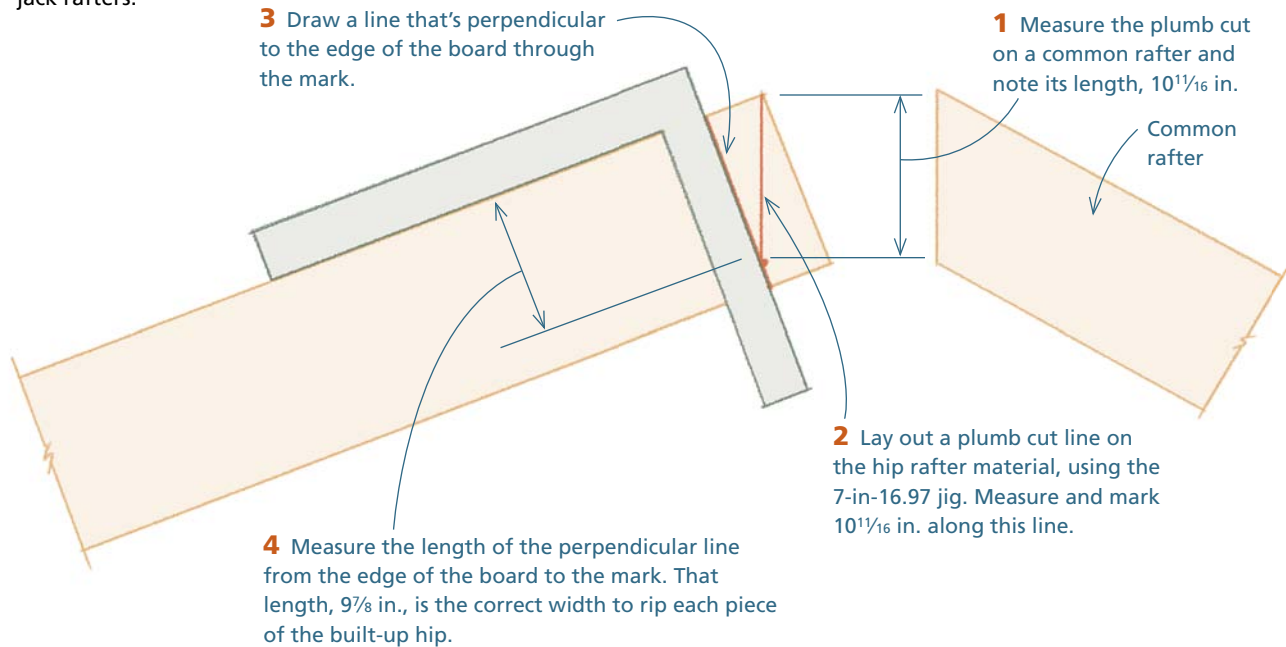

STEP 12 Rip the material

1 Find the backing angle for hips and valleys for a 7-in-12 roof. It should be written on the jig (see the sidebar on p. 120). Set your circular saw to that angle, which is 21° (rounded).

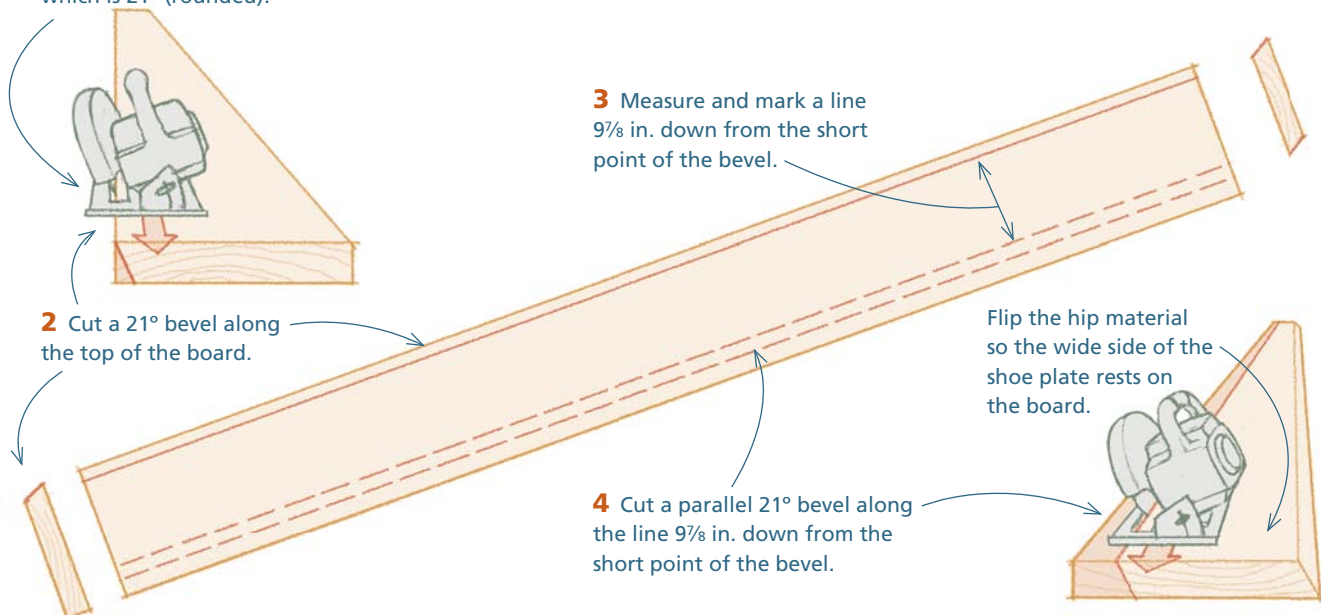

STEP 13 Lay out and cut the top plumb cut

For each half of the built-up hip, use the 7-in-16.97 jig to lay out the top plumb cut. When nailed together, the bevels will form an arrow pointing out from the board.

- 1 Mark a plumb line on the face of the board that has the long point of the ripped bevel at the top.

This side will be the inside face when the two parts are sandwiched together.

Cross section of hip material



- 3 Orient the cut so that the line ends up as the long point of the bevel.

Waste

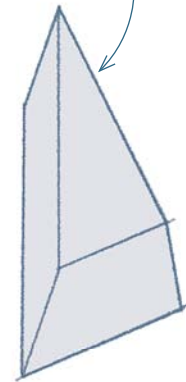

- 2 Set your saw to a 45° bevel, and cut along the line.

STEP 14 Lay out and cut the bird's mouth

- 1 Flip the hip material over. From the bottom of the plumb cut, at the short point of the bevel, measure and mark $13\frac{4}{16}$ in.

Short point at the bottom of the plumb cut

- 2 At the mark, use the jig to scribe a level line.

- 3 Mark $8\frac{7}{8}$ in. out along the level line. This is equal to the length of the hip rafter layout on the plate, $8\frac{1}{2}$ in., plus $\frac{3}{8}$ in. for clearance.

- 5 Cut the level line of the bird's mouth with the saw set to 0°. Set the saw to a 45° bevel before cutting the plumb line. Make the line the long point of the bevel. Finish the cut with a handsaw.

- 4 Use the rafter jig to mark a plumb line down from the mark to complete the bird's-mouth layout.

STEP 15 Assemble and install the built-up hip

1 Nail the two parts of the built-up rafter together.

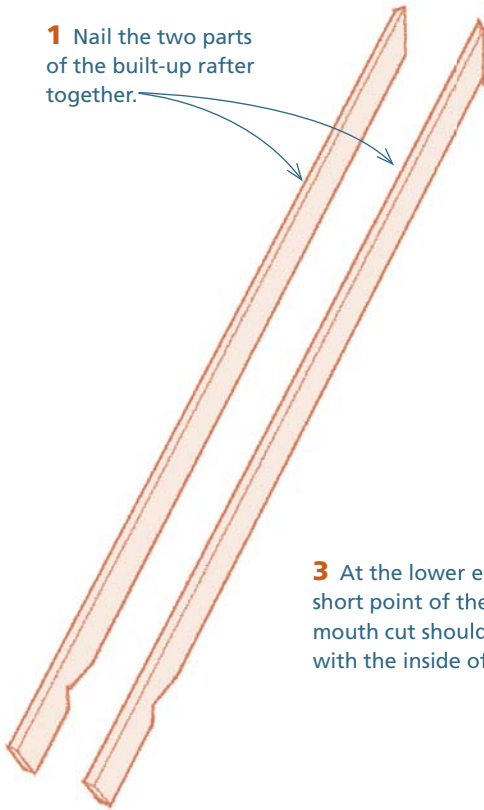

2 At the top, the built-up rafter fits snugly in the intersection of the side king common and the end king common rafters.

End king common

Side king common

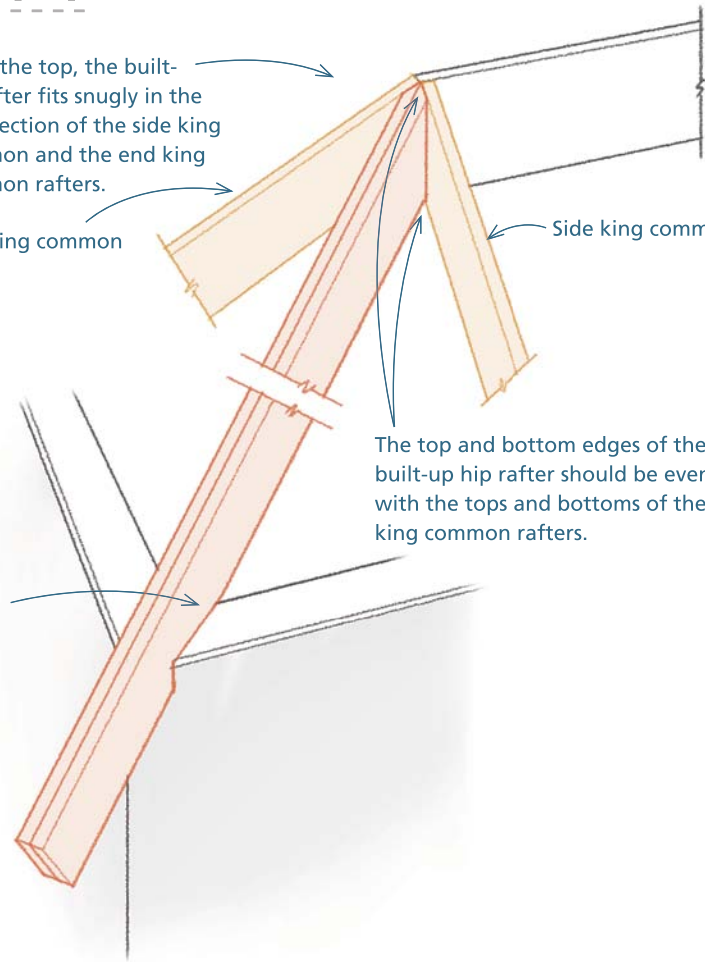

3 At the lower end, the short point of the bird's-mouth cut should align with the inside of the wall.

TOP TIP

Orienting the Rafter Jig

.....
You can't always set the fence of the rafter jig against the top of the board. Occasionally, you run out of material at the lower end of the board before you're able to lay out the plumb cut of the rafter tail. Another instance is when you rip a backing bevel along the top edge of a hip rafter. This creates an awkward surface on which to hook the fence. In both cases, you can rotate the jig and set the fence along the bottom edge.
.....

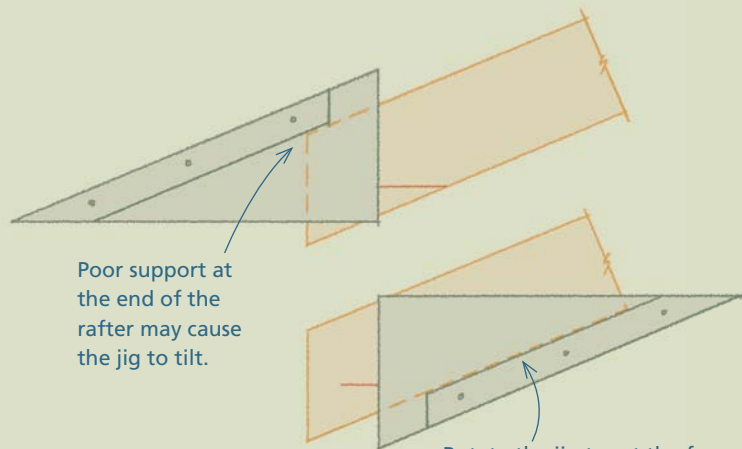

Poor support at the end of the rafter may cause the jig to tilt.

Rotate the jig to set the fence against the bottom of the rafter for better support.

WAYS OF WORKING

Getting Hips and Valleys in Plane with the Rest of the Roof

Laying out hip or valley rafters so that they provide full bearing of the jack rafters yet stay in line along the top plane of the roof is one of the most challenging layout tasks in roof framing.

LAYOUT IS THE SAME FOR ALL METHODS

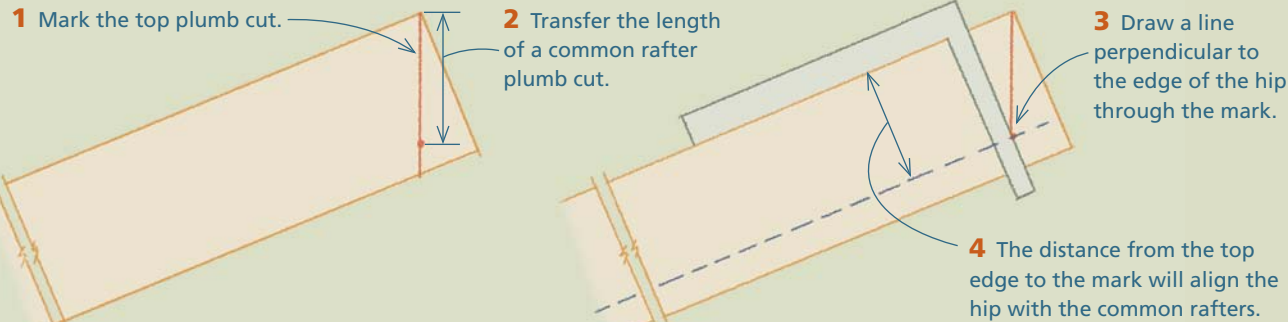
- 
- 1 Mark the top plumb cut.
 - 2 Transfer the length of a common rafter plumb cut.
 - 3 Draw a line perpendicular to the edge of the hip through the mark.
 - 4 The distance from the top edge to the mark will align the hip with the common rafters.

• TOPS OF HIPS IN PLANE

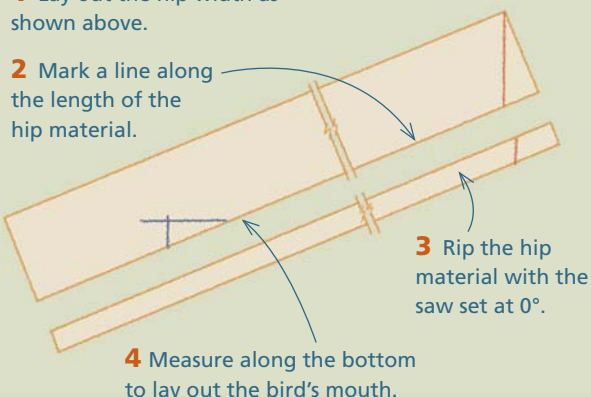
- 
- 1 Lay out the hip width as shown above.
 - 2 Mark a line along the length of the hip material.
 - 3 Rip the hip material with the saw set at 0° .
 - 4 Measure along the bottom to lay out the bird's mouth.

• DROPPING THE HIP

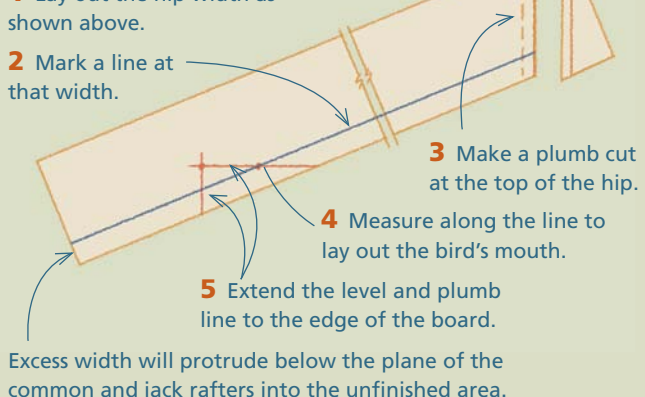
- 
- 1 Lay out the hip width as shown above.
 - 2 Mark a line at that width.
 - 3 Make a plumb cut at the top of the hip.
 - 4 Measure along the line to lay out the bird's mouth.
 - 5 Extend the level and plumb line to the edge of the board.
- Excess width will protrude below the plane of the common and jack rafters into the unfinished area.

• TOP AND BOTTOM OF HIPS IN PLANE

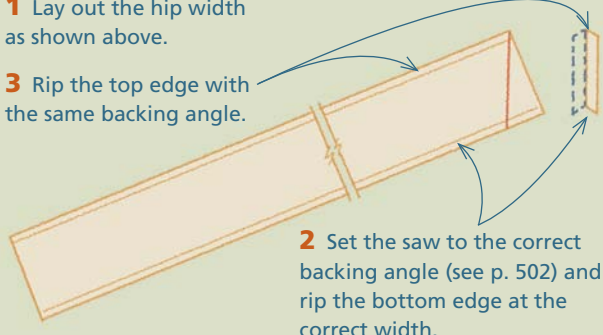
- 
- 1 Lay out the hip width as shown above.
 - 2 Set the saw to the correct backing angle (see p. 502) and rip the bottom edge at the correct width.
 - 3 Rip the top edge with the same backing angle.

• TOP AND BOTTOM EDGES OF VALLEY IN PLANE

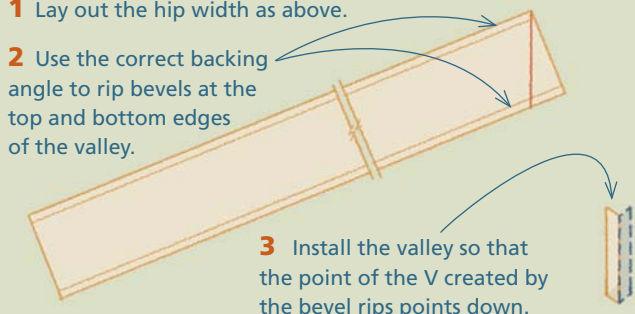
- 
- 1 Lay out the hip width as above.
 - 2 Use the correct backing angle to rip bevels at the top and bottom edges of the valley.
 - 3 Install the valley so that the point of the V created by the bevel rips points down.

STEP 16 Do the math for the jack rafters

The key dimensions for the jack rafters are taken off the top plate (7.63, 23.63, etc.). To calculate length, multiply each of these numbers by the hypotenuse of the base-1 triangle for a 7-in-12 pitch. That number, which should be written on your rafter jig, is 1.158.

The math looks like this:

A $7.63 \times 1.158 = 8.84$ ($8\frac{13}{16}$ in.)

B $23.63 \times 1.158 = 27.36$ ($27\frac{3}{8}$ in.)

C $39.63 \times 1.158 = 45.89$ ($45\frac{7}{8}$ in.)

D $55.63 \times 1.158 = 64.42$ ($64\frac{7}{16}$ in.)

E $71.63 \times 1.158 = 82.95$ ($82\frac{15}{16}$ in.)

The dimensions— $8\frac{13}{16}$ in., $27\frac{3}{8}$ in., $45\frac{7}{8}$ in., $64\frac{7}{16}$ in., and $82\frac{15}{16}$ in.—represent the distances needed between the short point of the top plumb cut and the short point of the level cut of the bird's mouth, as measured along the bottom of the rafters.

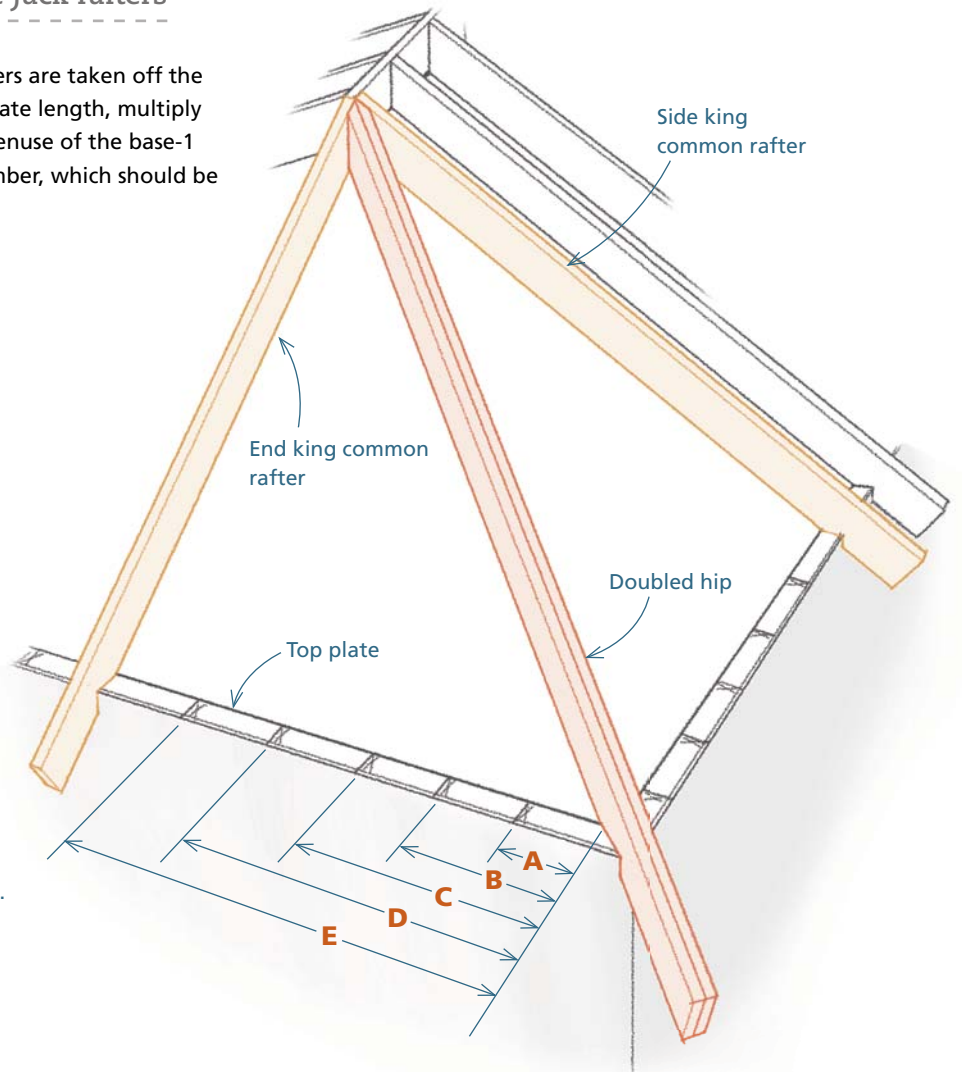

STEP 17 Lay out and cut the jack rafters

1 Use the 7-in-12 jig to lay out the top plumb cut.

2 Set a circular saw to a 45° bevel and cut along the line. Orient bevels in opposing directions for each pair of rafters. Cut down for the first rafter and up for the second.

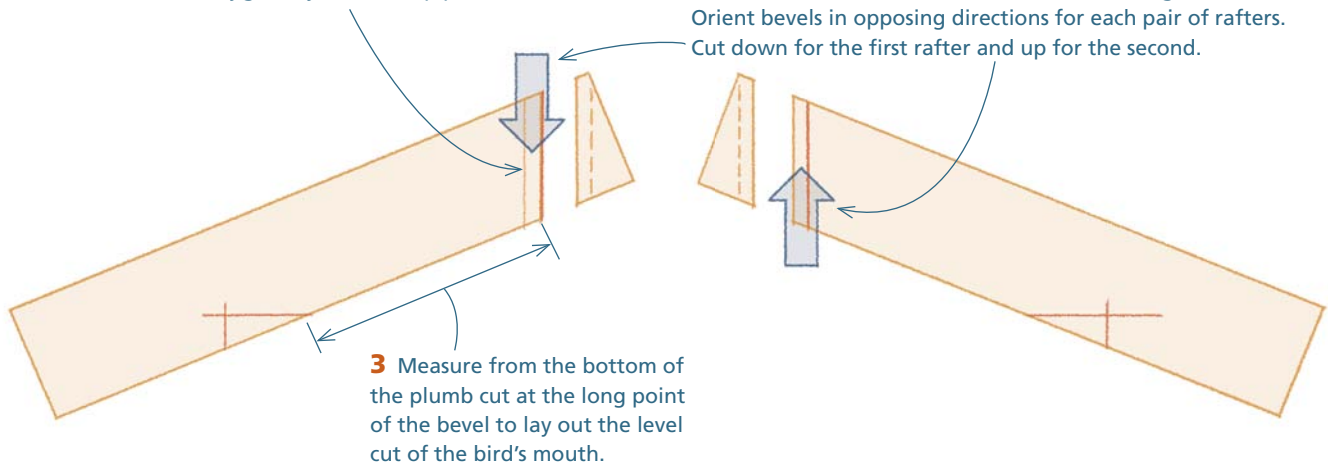

3 Measure from the bottom of the plumb cut at the long point of the bevel to lay out the level cut of the bird's mouth.

STEP 18 Install the jack rafters

1 There is no need to lay out the rafter locations on the hip. Check the hip for straightness and, if need be, use a brace to force it into a straight line.

This bevel cut is needed to allow the tops of the jack rafters to fit against the sides of the hip, which is running at a 45° angle to the jack rafters.

End king common rafter

Side king common rafter

3 Fit the top even with the top outside edge of the hip and nail it in place. To avoid forcing the hip out of line, install the jacks in opposing pairs.

2 Install the bottoms of the jacks as you did the common rafters, with the short point of the bird's mouth even with the inside of the wall.

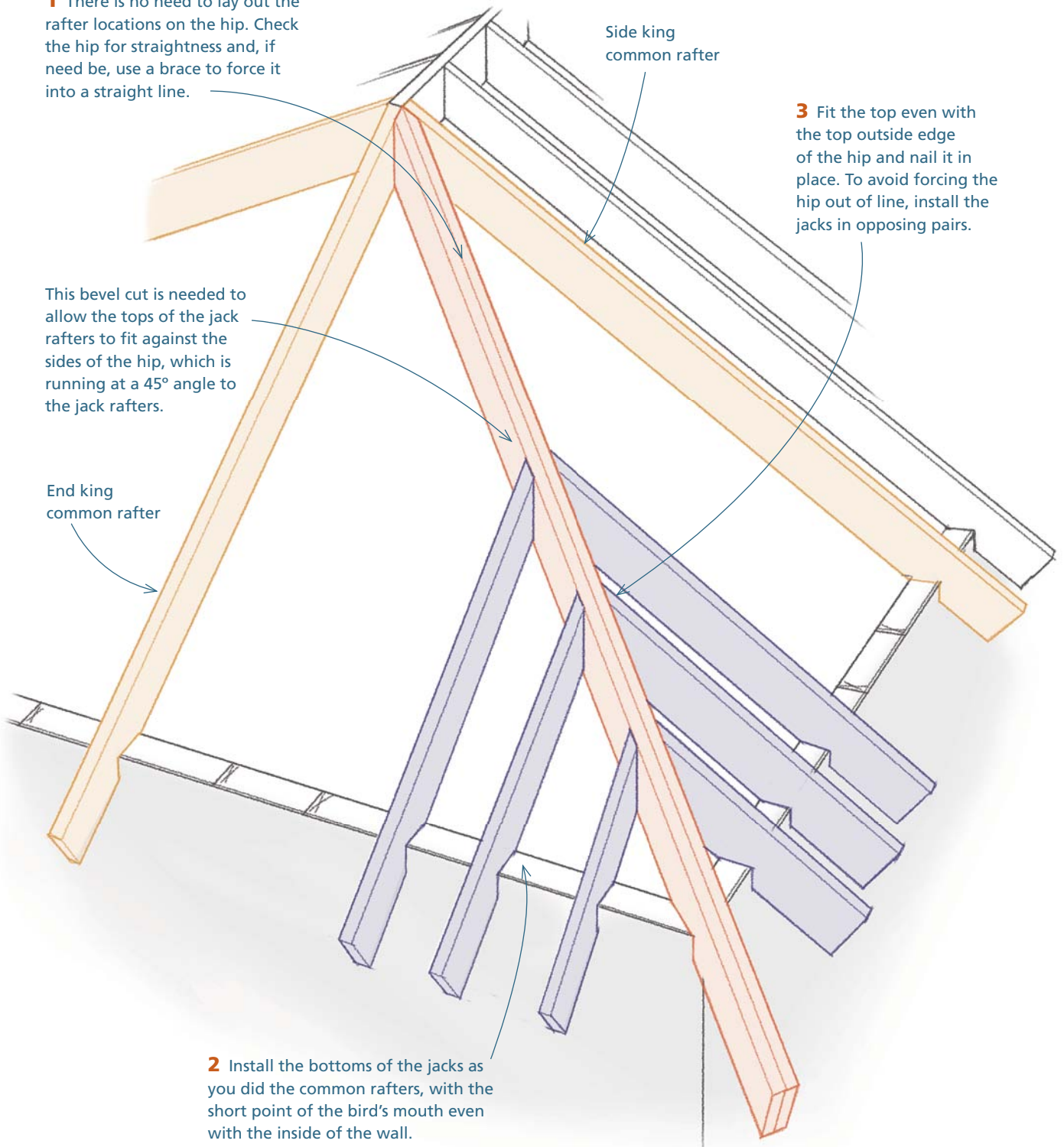

Building a Roof with a True Valley

In this third example, the main portion of the house is 24 ft. wide. An intersecting wing is 16 ft. wide. The planned pitch for both sections of the roof is 12-in-12. A 10-in. rough eave is planned; the rafter tails will be left long and cut in place later.

The intersection of the two roofs will form two true valleys. In a true valley, the valley rafter serves as a beam that is connected to and supports the weight of the jack rafters on both sides of the valley. The area under the valley is open and can be used for living space or storage.

The walls of the house are 2x4s. The common and jack rafters will be made from 2x8s. The ridges and the built-up valleys will be made from 2x12s.

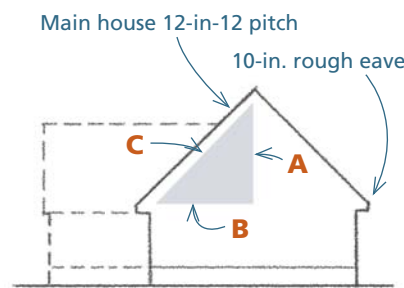
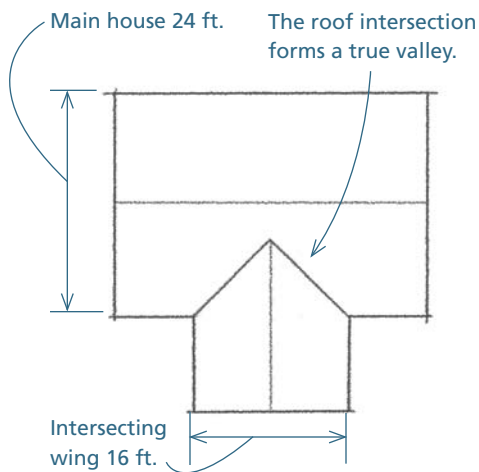

A = 139.75 B = 139.75 C = 197.64

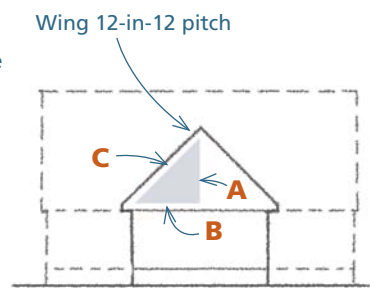

A = 91.75 B = 91.75 C = 129.75

JIGS & FIXTURES

Make a 12-in-16.97 Jig

You don't need a 12-in-12 jig for the common and jack rafters because both the plumb and level cuts are 45°. Use a large triangular square to lay out these cuts.

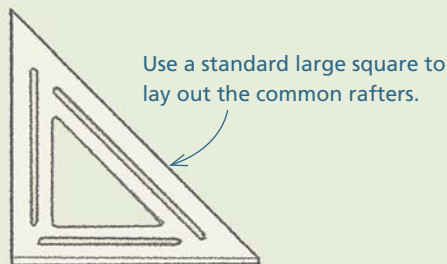

Make a 12-in-16.97 jig for the valley rafters using the techniques described in "Building a Gable Roof" on p. 105.

Write the base-1 proportions (p. 503), the pitch in degrees (p. 505), and the backing angle (p. 502) on the jig.

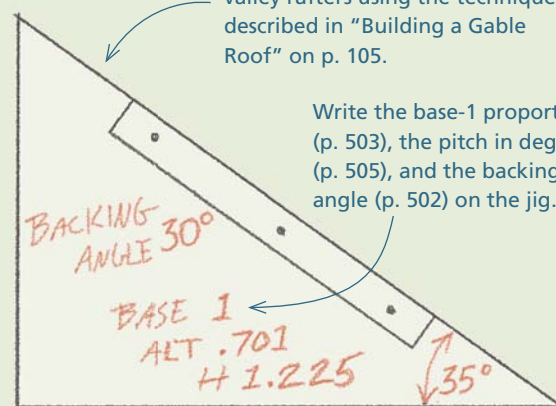

STEP 1 Lay out and install the ridges and the common rafters

The entire ridge for the main section can be installed at this point. The ridge for the wing is lower and must be attached to the main roof. In this framing plan, the lower ridge and the valleys are carried by a header, which is supported on each side by trimmers. The plan specifies double 2x8s for the trimmers and a double 2x12 for the header. Steel hangers are specified for carrying the header.

● UPPER RIDGE ON MAIN HOUSE

Using the techniques described in "Building a Gable Roof" on p. 105, lay out, cut, and install the ridges and common rafters.

- 1** Lay out the position of the valleys on the top plates. Locate the trimmers just outside the valleys as shown.

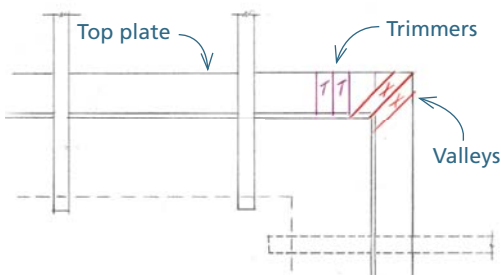

- 2** After laying out the bird's mouth of the trimmers, cut the ends at a 45° angle. This cut allows the valleys to run past the trimmers.

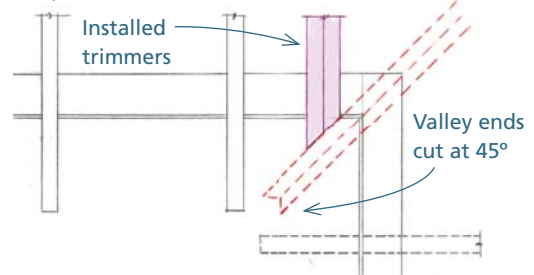

To prevent overloading one side of the upper ridge, leave the common rafters off until opposing rafters are installed.

Main roof common rafters

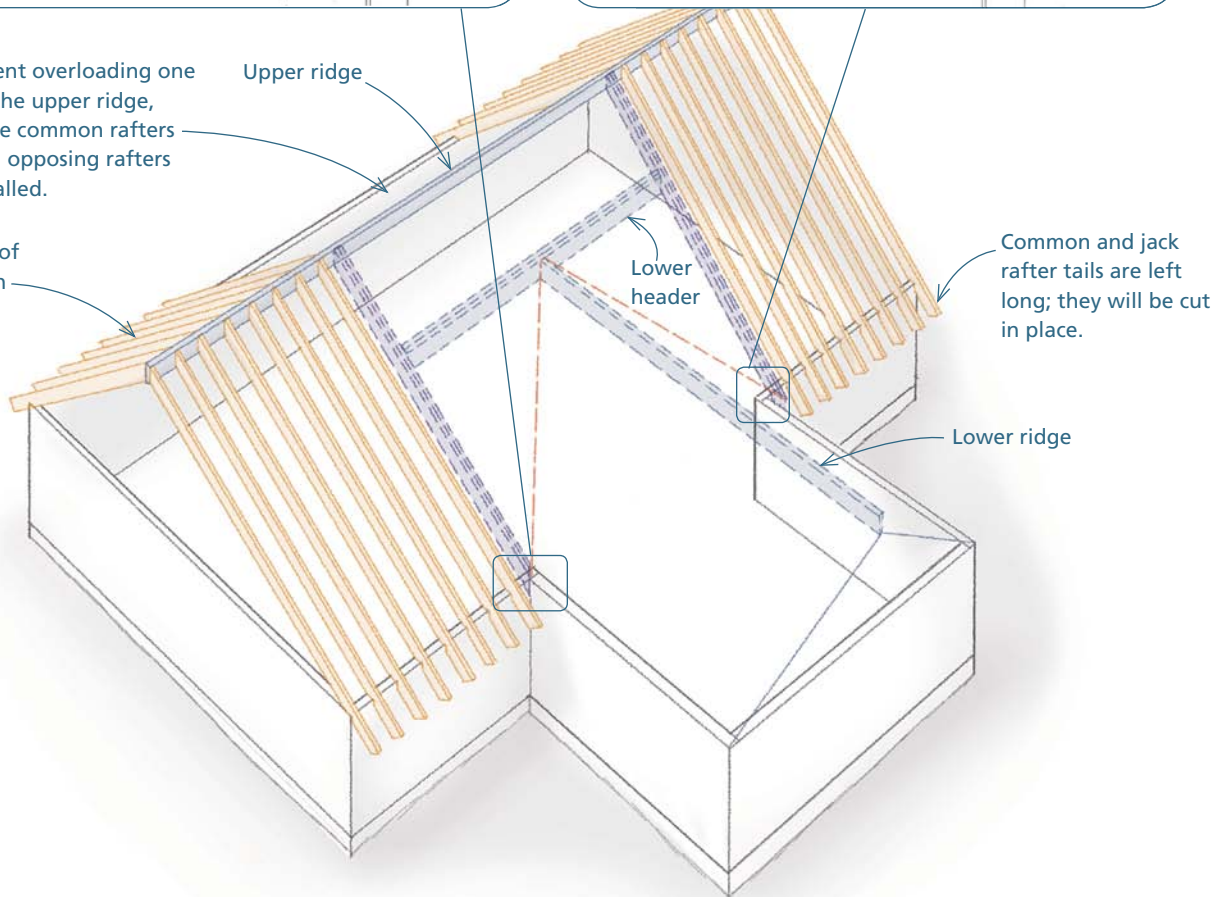

STEP 1 Lay out and install the ridges and the common rafters (continued)

• LOWER RIDGE ON WING

The plan specifies double 2x8s for the trimmers and a double 2x12 to carry the header. Steel hangers are specified for carrying the lower header.

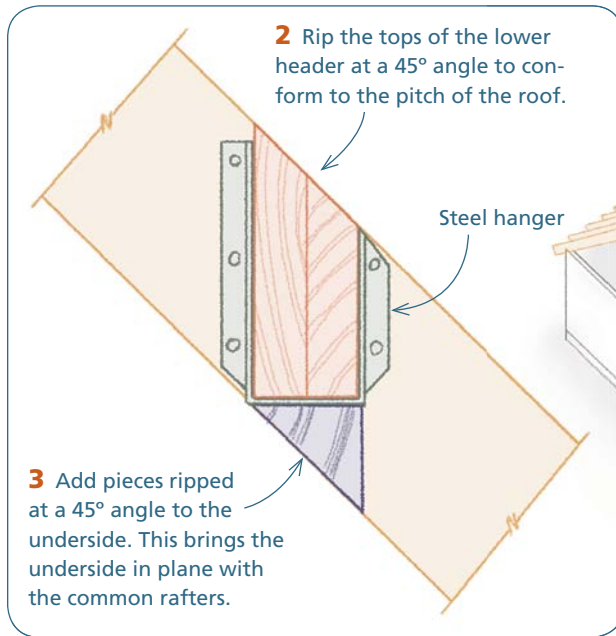

1 Set the header at the same height as the lower ridge with the bottom even with the underside of the trimmer.

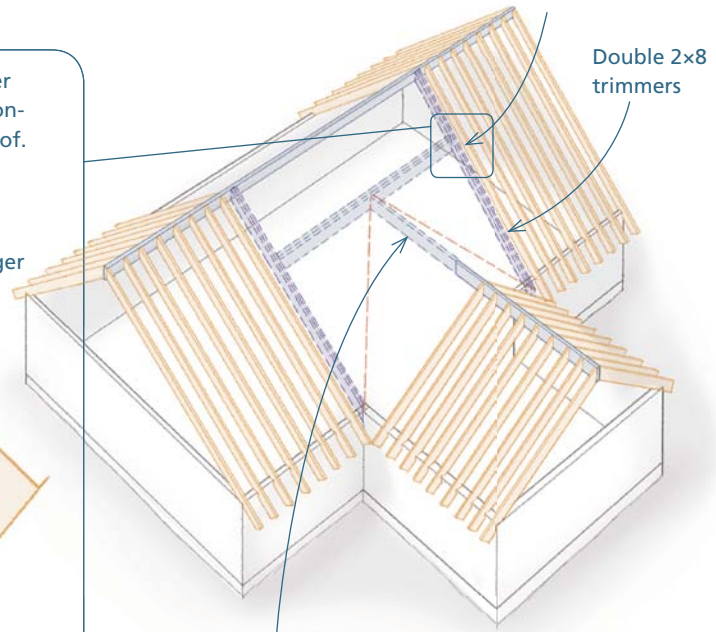

STEP 2 Prep the valley material

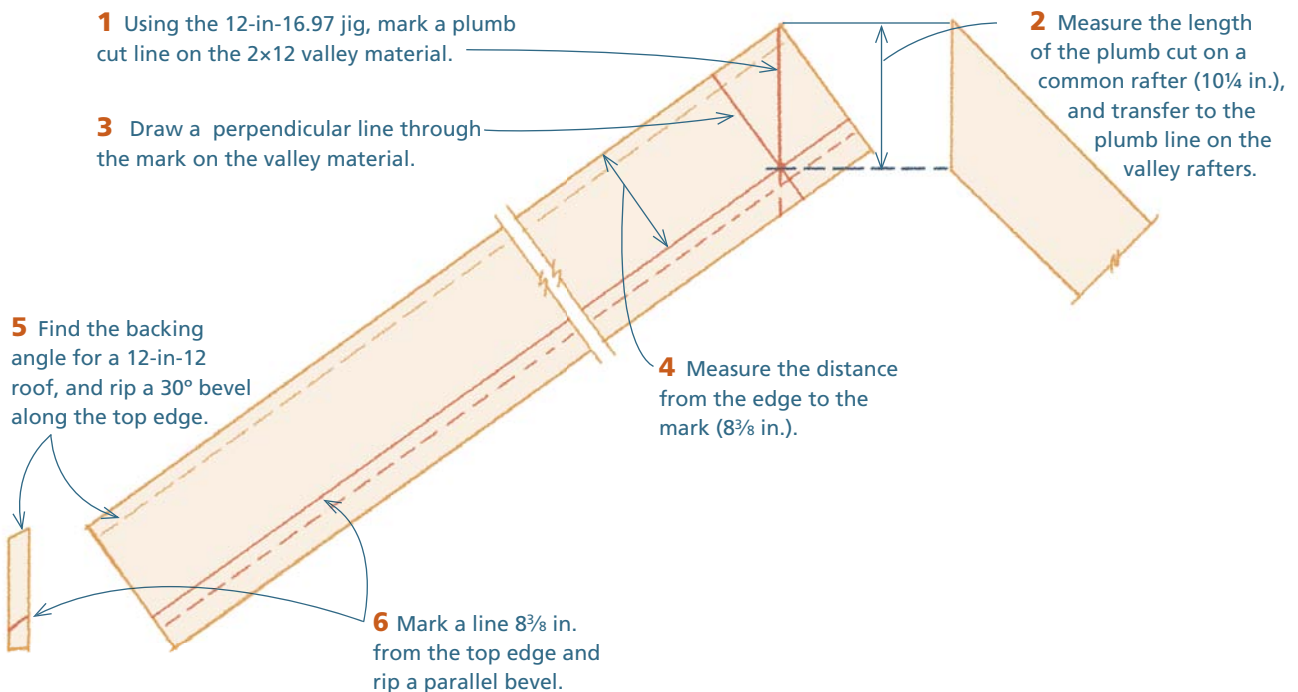

STEP 3 Lay out and cut the plumb cuts and the bird's mouth of the valleys

1 The key dimension for finding the base of the valley measuring triangle is the base of the common rafter measuring triangle. Multiply that dimension, 91.75 in., by $\sqrt{2}$ to determine the base of the measuring triangle for the valley: $\sqrt{2} \times 91.75 = 129.75$.

2 Find the hypotenuse of the base-1 triangle for a 12-in-16.97. (It should be on your jig.) Multiply that number, 1.225, by 129.75 to determine the hypotenuse of the measuring triangle for the valley: $1.225 \times 129.75 = 158.95$ ($158\frac{15}{16}$ in.).

5 From that point, use the jig to lay out the bird's mouth. Measure the layout line on the top of the wall to determine the correct length (about 6 in.) to make the level line of the bird's mouth.

3 Lay out the plumb cut at the top of the valley, set your saw to a 45° bevel, and cut along the plumb cut line.

4 From the short point of the plumb cut, measure and mark $158\frac{15}{16}$ in. along the bottom.

6 Cut the bird's mouth with the saw set to 0°.

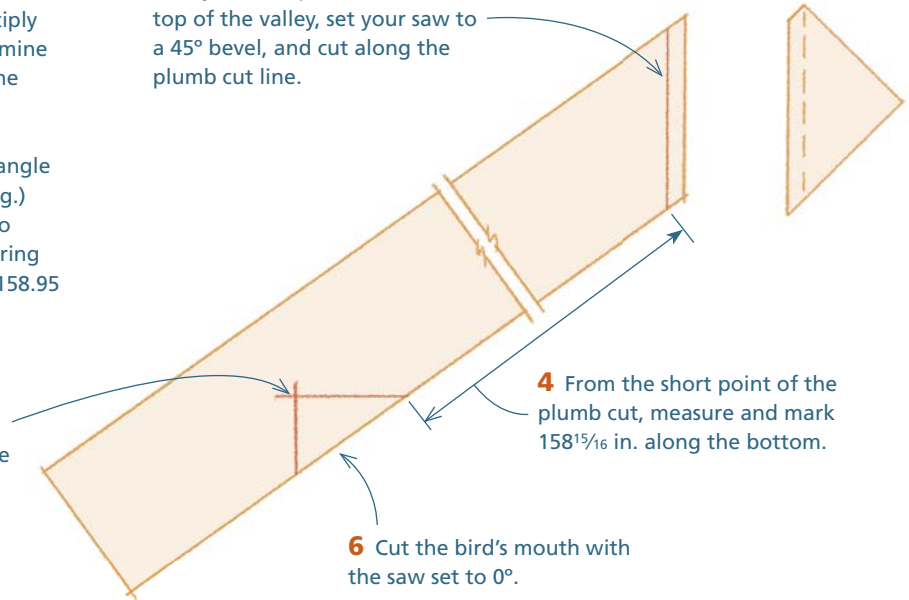

STEP 4 Lay out and cut the tails of the valleys

Because the rafter tails converge at the valley, it's difficult to cut the ends of the valleys in place. To lay out and cut the valley rafters prior to their installation, follow these steps.

4 The valley rafter runs at a 45° angle to the wall. The distance from the inside of the wall to the end of the rafter tail is $\sqrt{2} \times 12.5 = 17.68$.

1 Find the length of the base of the measuring triangle for the rafter tail. The rough eave is specified at 10 in. from the outside face of the wall including a 1½-in. subfascia.

3 The walls are 4 in. thick so the plumb cuts need to be 12.5 in. from the inside face of the wall.

2 The valley plumb cut is 8½ in. from the outside face of the wall.

5 Multiply 17.68×1.225 to find the hypotenuse of the measuring triangle for the rafter tail = 21.66 ($21\frac{5}{8}$ in.).

7 Cut a 45° bevel along the plumb line.

6 Use the jig to mark a plumb line 21.66 ($21\frac{5}{8}$ in.) from the level line of the bird's mouth.

8 Use the jig to lay out the level line for the tail at the desired location. Set the saw to 0° and cut along the line.

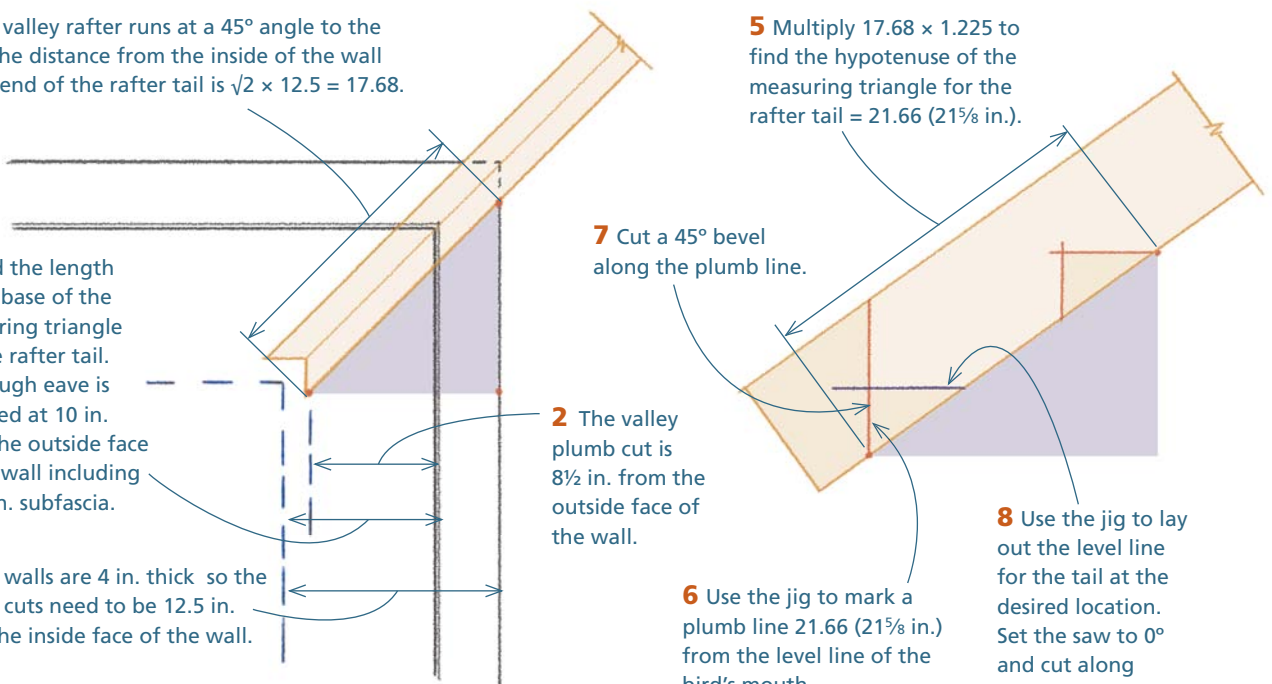

STEP 5 Install the valley rafters

1 Install the first board of the built-up valley.

Header

Lower ridge

2 Install the second board back-to-back, then nail the two parts together.

4 The bevels at the upper end of the valleys should fit into the right angle formed by the header and the ridge.

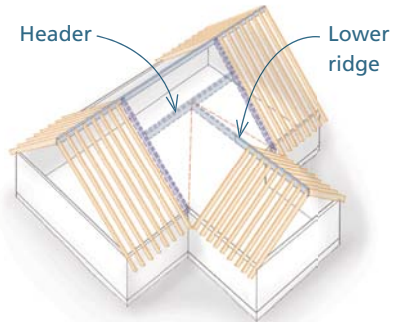

3 The bevels along the top and bottom edges of the built-up valley should form parallel Vs (with the points down) in cross section.



5 The bevels at the lower end of the valley should run parallel with the walls and form a right angle.

STEP 6 Lay out the common rafters in the area above the header

1 On the upper ridge, find the center of the space between the two trimmers.

2 Lay out half of the upper ridge in a continuation of the 16-in. o.c. pattern of the common rafters to the left of the trimmer. Stop at the center mark.

3 Butt a story stick against the left trimmer and record the layout. Reverse the story stick, butt it against the right trimmer, and transfer the mirror-image layout.

4 Use the story stick to transfer an identical layout to the header.

5 Use the story stick to mark a mirror-image layout along the lower ridge.

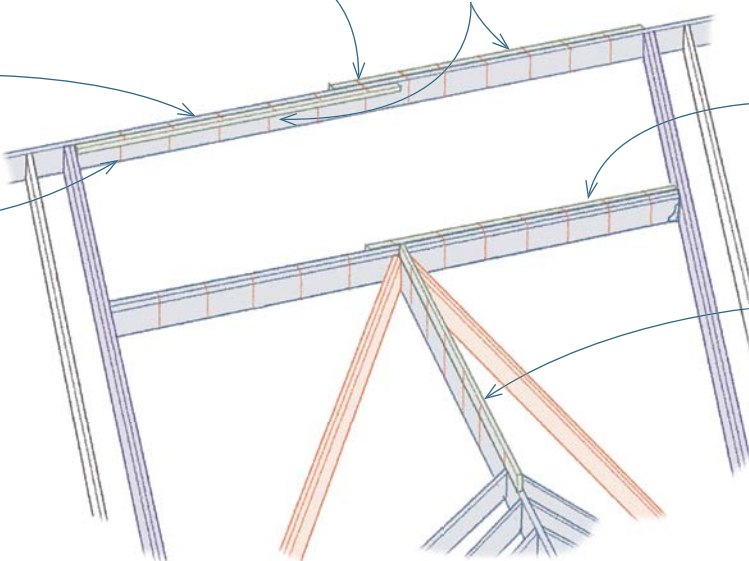

STEP 7 Calculate the measuring lengths of the jack rafters

1 At the upper end of the valleys, measure the distances from the edge of the valleys to the far side of each rafter location. You can do this along the header or along the ridge; they should be identical. In this example, those distances are:

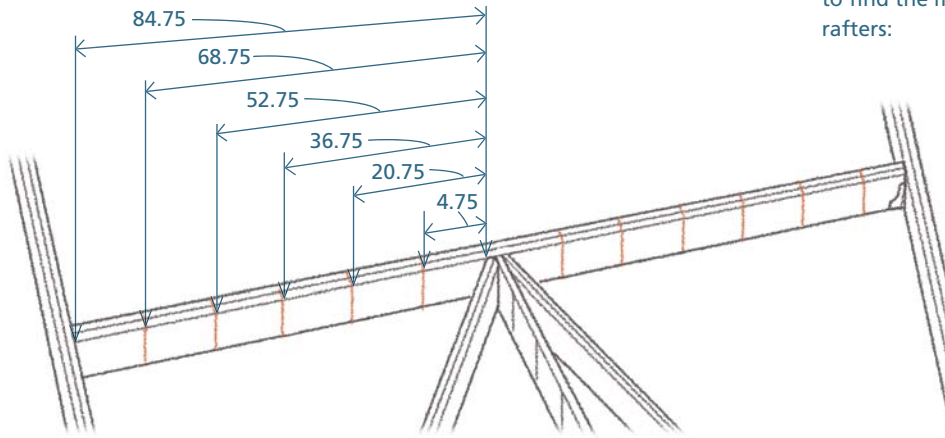

2 These dimensions are equal to the bases of the measuring triangles needed for the jack rafters. The hypotenuse of a base-1 measuring triangle for a 12-in-12 roof is 1.414, which is $\sqrt{2}$. Multiply $\sqrt{2}$ by each of these dimensions to find the measuring lengths of the jack rafters:

$$\begin{aligned}\sqrt{2} \times 4.75 &= 6.72 \text{ (6}\frac{1}{16}\text{ in.)} \\ \sqrt{2} \times 20.75 &= 29.34 \text{ (29}\frac{3}{8}\text{ in.)} \\ \sqrt{2} \times 36.75 &= 51.97 \text{ (52 in.)} \\ \sqrt{2} \times 52.75 &= 74.56 \text{ (74}\frac{5}{8}\text{ in.)} \\ \sqrt{2} \times 68.75 &= 97.23 \text{ (97}\frac{1}{4}\text{ in.)} \\ \sqrt{2} \times 84.75 &= 119.85 \text{ (119}\frac{7}{8}\text{ in.)}\end{aligned}$$

STEP 8 Lay out, cut, and install the jack rafters

1 At the top of each opposing pair of rafters, use your square to lay out the 12-in-12 plumb cut, which is a 45° angle.

2 Set your saw to 0° and cut along the line.

3 From the long point of the cut, measure and mark the length you've calculated for the rafter.

4 At the mark, lay out a second plumb cut.

5 Set the saw to a 45° bevel and cut along the line.

6 Install the jacks in opposing pairs.

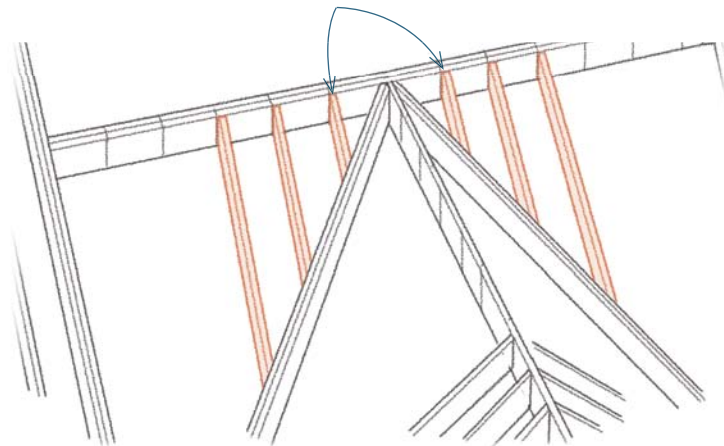

Install the Remaining Common Rafters

Fill in the common rafters in the area above the header and on the other side of the upper ridge.

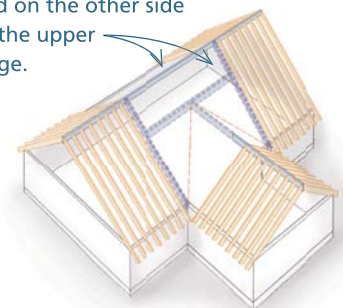

Building a Doghouse Dormer

In this example, the 10-in-12 roof is partially framed and an opening needs to be framed for the dormer. The dormer will be 48 in. wide with a front wall that's 60 in. high. The pitch of the dormer roof is 10-in-12—the same as the main roof.

The walls of the dormer will be framed with 2×4s. The rafters will be made of 2×8s, and the ridge will be made of a 2×12. The rafters on the main roof are made of 2×10s. A rough eave of 5-in. is specified.

The valleys for the dormer will be “blind” valleys. A blind valley is formed when one section of a gable roof is built on top of another. These valleys are easier to build than true valleys; however, the space underneath them cannot be used.

STEP 1 Build the opening the correct size

• FIND THE WIDTH OF THE OPENING

- 1 The width of the dormer is specified at 48 in.
- 2 Subtract the two 4-in.-thick sheathed 2×4 walls.

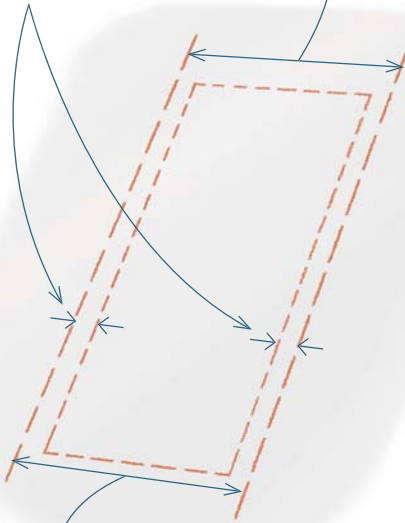

- 3 The opening between the trimmers will be 40 in. (48 in. minus 8 in.).

• FIND THE LENGTH OF THE OPENING

- 2 Cut a 2×4 that conforms to the roof pitch at 60½ in. (equal to the height of the wall plus the thickness of the roof sheathing), and nail it temporarily on the trimmer. The side with the short point of the cut should be even with the lower end of the opening. Brace the post plumb.

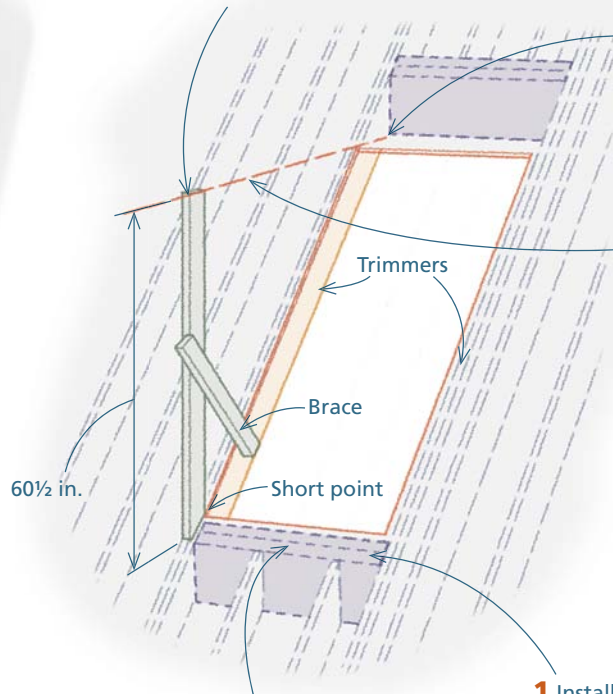

- 3 Use a level and a straightedge to make the top of the opening. Install the upper header of the opening so that the bottom is even with the mark.
- 4 To locate the bottom of the header, level over from the top of the post to the trimmer.

- 1 Install the header at the lower end of the opening.

The outside face of the 4-in.-thick front wall will sit on a header at the bottom of the opening.

STEP 2 Frame the walls

• BUILD THE FRONT WALL

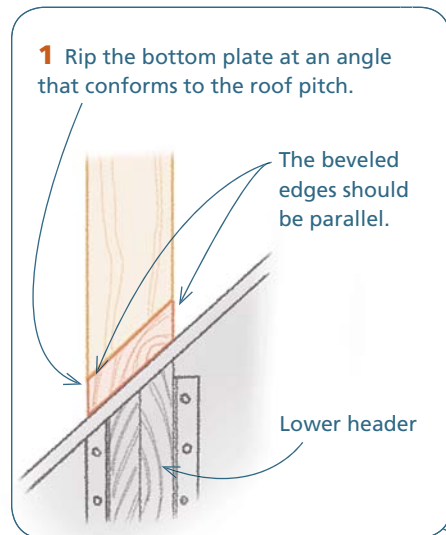

3 Build the wall with the rough opening for the window as specified in the plan.

4 Level over from the underside of the plate to the side of the opening.

5 Use a single top plate and make the height 1½ in. lower than the specified 60 in. Install a second top plate later to bring it up to full height.

2 The bottoms of the studs and corners need to be mitered to match the roof pitch.

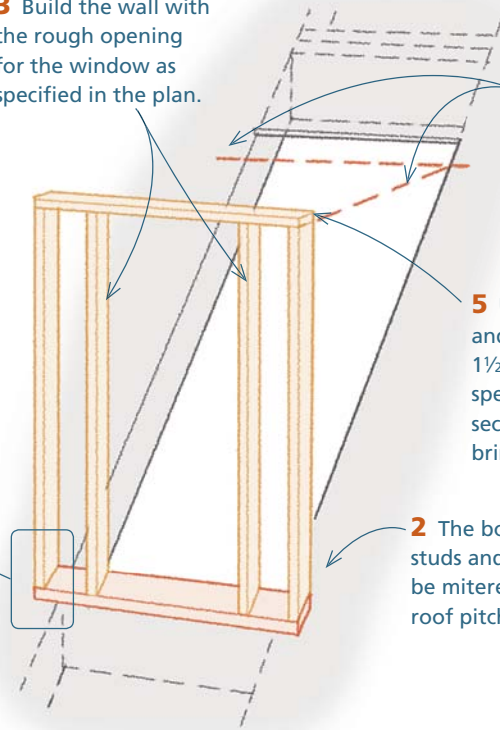

• SIDE WALL PLATES

6 Cut bottom plates to fit between the back of the wall and the previous mark. The cut at the lower end of the plate matches the roof pitch. The cut at the upper end is its complement.

9 Cut and install a top plate; the end cuts match the roof pitch.

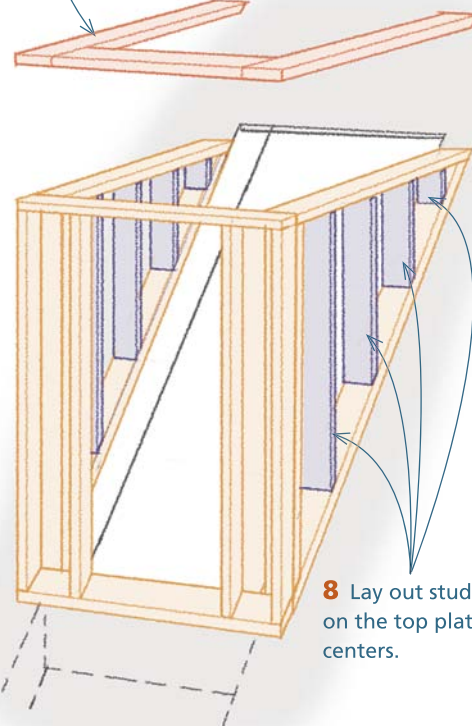
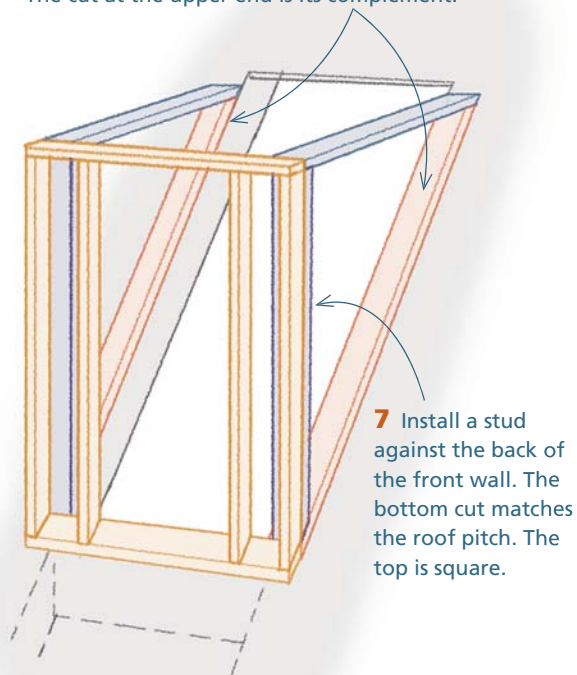

STEP 3 Cut and install the ridge

Using the techniques discussed in "Building a Gable Roof" on p. 105, determine the correct width of the ridge ($9\frac{7}{16}$ in.) here and rip the ridge to that width. Then calculate the measuring triangle for the dormer roof.

KEY DIMENSIONS

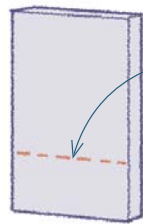
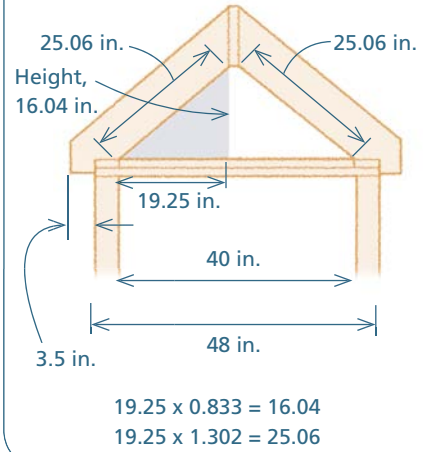

1 Measure and mark a $16\frac{7}{16}$ -in. line across a wide board.

2 Attach the board to the inside of the front wall with the $16\frac{7}{16}$ -in. line even with the top of the wall. Center the board, by eye, on the wall.

3 Use a jig to cut the end of the ridge. This angle is the same as the roof pitch. Set the ridge on the board with the cut end against the sheathing.

4 Adjust until level.

5 Center ridge by eye, and fasten temporarily with one small nail.

6 Use a level to mark a line on the ridge plumb with the outside face of the front wall. Cut to the line.

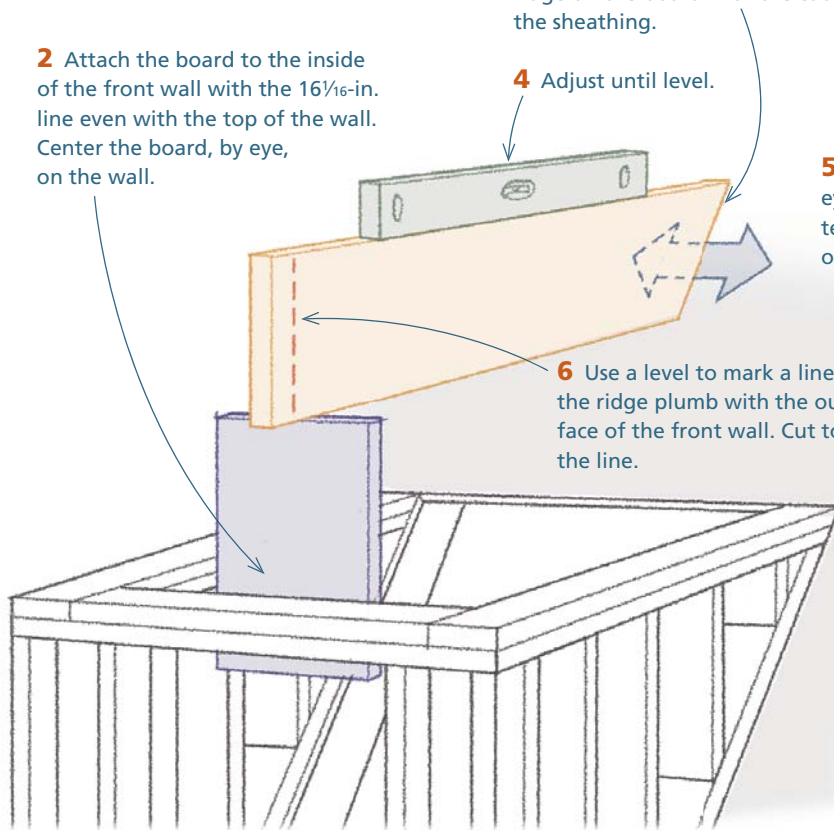

STEP 4 Cut and install the common rafters

Using the techniques discussed in "Building a Gable Roof" on p. 105, cut the common rafters, including the tails.

1 The first pair of rafters centers the front of the ridge between the two side walls.

2 Remove the nail connecting the cut end of the ridge to the roof deck.

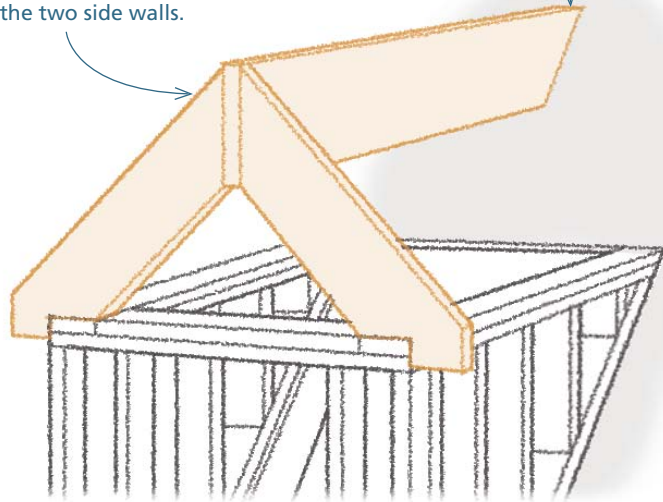

3 Lay out the rafter locations at 16-in. intervals.

4 Install a second pair of rafters to center the ridge.

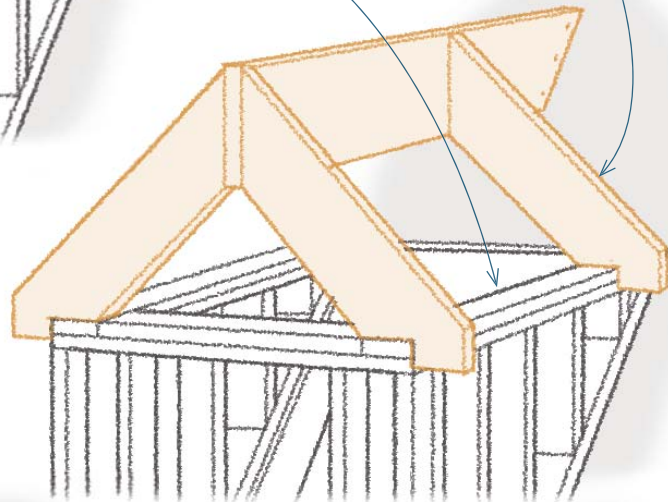

5 Nail the ridge to the sheathing.

6 Install the rest of the common rafters.

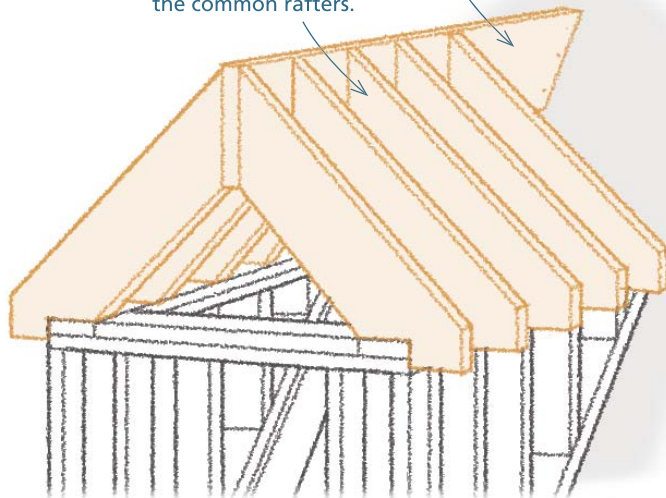

STEP 5 Lay out and install the valley plate

The jack rafters need to rest on a plate (sometimes called a sleeper). Because of its thickness, you need to install the plate inside the valley line; the object is to get the top outside edge of the plate in plane with the tops of the common rafters.

1 Use a straightedge to extend the plane of the common rafters to the deck of the main roof.

2 Snap a line between the top and bottom points to lay out the valley.

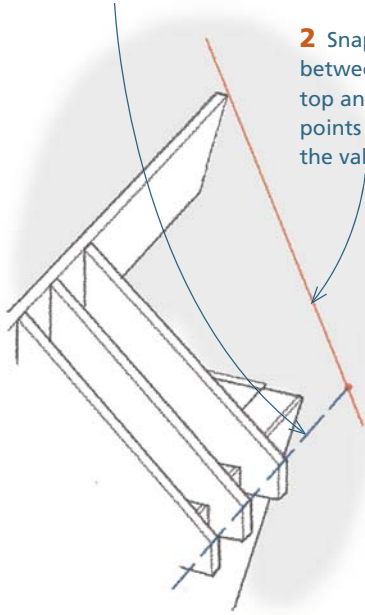

3 Set a scrap of wood along the valley line.

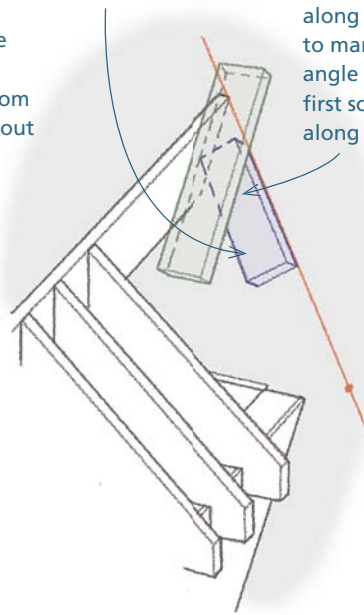

4 Set a second scrap along the ridge. Scribe along the edge to mark an angle on the first scrap. Cut along the line.

5 Place scrap piece against the ridge. Move it along the ridge until the top corner is even with the top outside corner of the ridge.

6 Mark the sheathing along the edge, and measure the distance from the valley line.

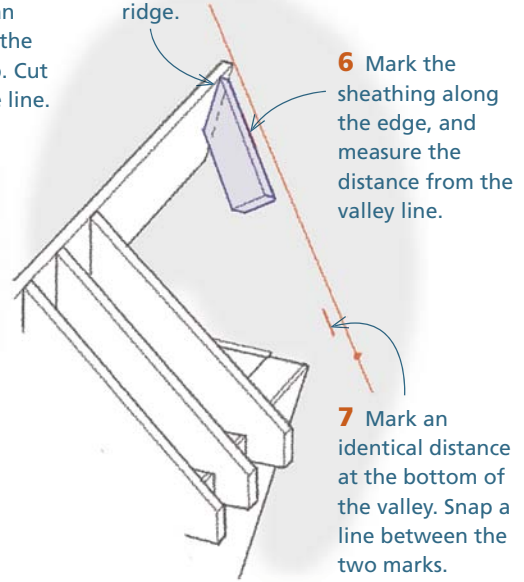

7 Mark an identical distance at the bottom of the valley. Snap a line between the two marks.

8 Slide the cut block down to the short point on the level cut on the ridge. Scribe along the edge of the block.

9 Measure the distance between this line and the valley plate line. This is the minimum needed for the valley plate.

10 Measure the length of the valley plate line, and cut the valley plate with the appropriate miters at the ends.

11 Nail the valley plate along the line.

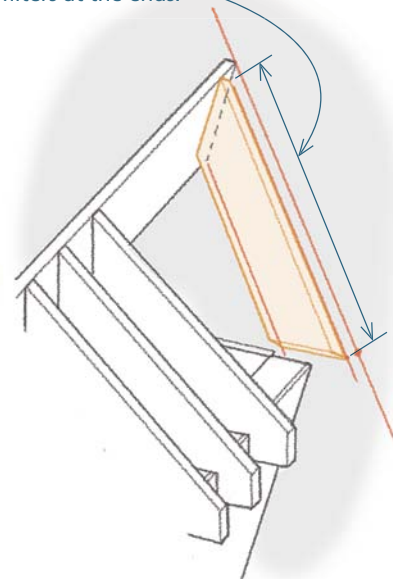
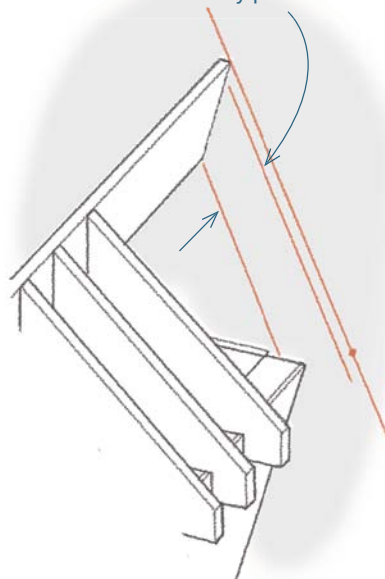
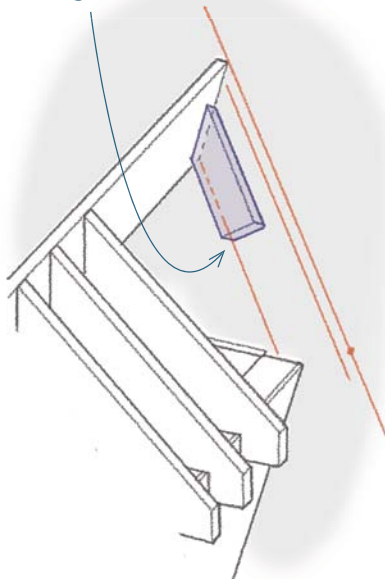

STEP 6 Lay out the valley jack locations

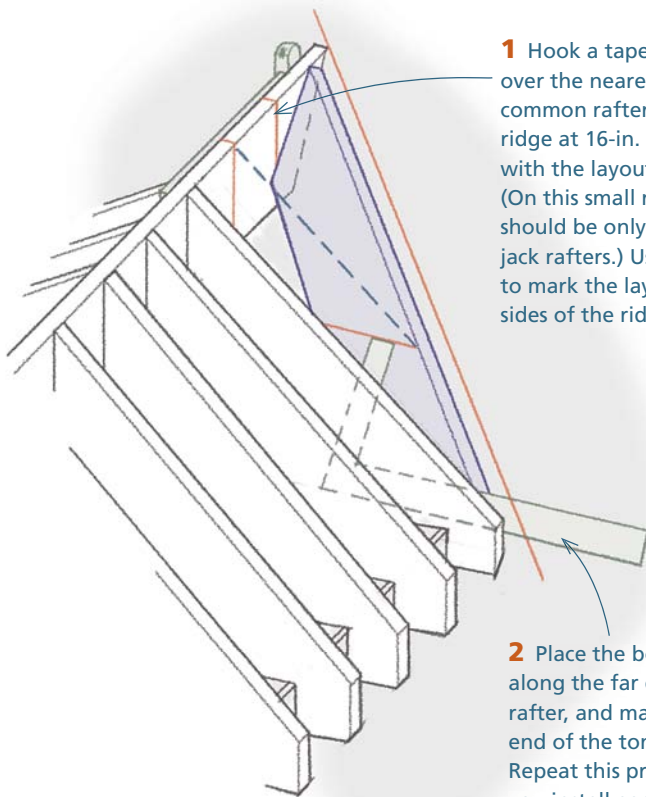

1 Hook a tape measure over the nearest installed common rafter. Mark the ridge at 16-in. intervals, with the layout set ahead. (On this small roof, there should be only one or two jack rafters.) Use a square to mark the layout on both sides of the ridge.

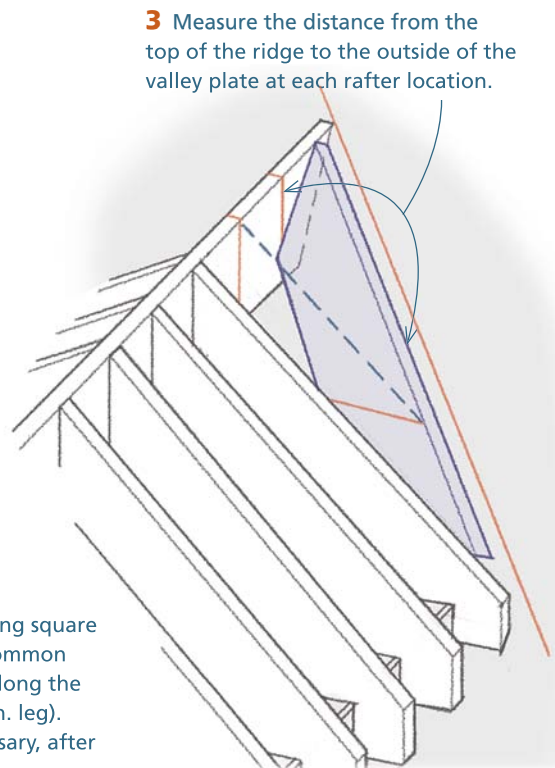

2 Place the body of a framing square along the far edge of the common rafter, and mark the plate along the end of the tongue (the 16-in. leg). Repeat this process, if necessary, after you install each jack rafter.

3 Measure the distance from the top of the ridge to the outside of the valley plate at each rafter location.

4 At the top of a piece of rafter material, lay out a plumb cut with the rafter jig. Set the saw to 0° and make the plumb cut. These cuts are identical to the top cuts on the common rafters.

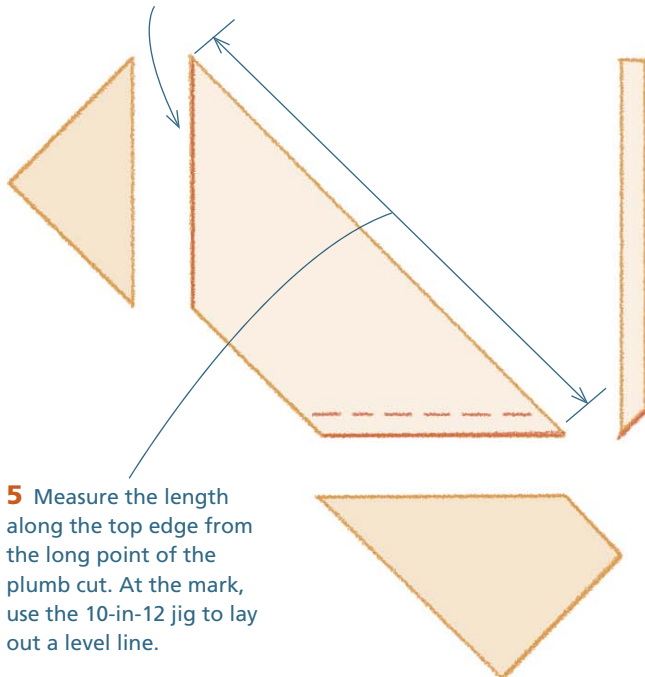

5 Measure the length along the top edge from the long point of the plumb cut. At the mark, use the 10-in-12 jig to lay out a level line.

7 Nail the jacks in place.

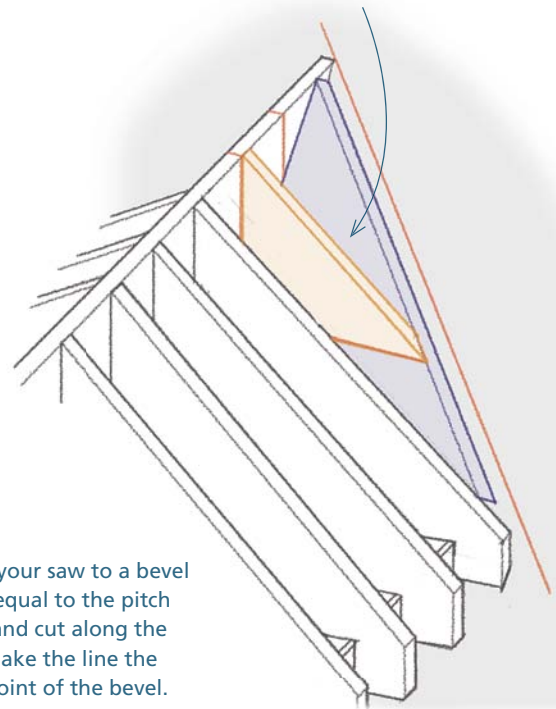

6 Set your saw to a bevel that's equal to the pitch (40°), and cut along the line. Make the line the long point of the bevel.

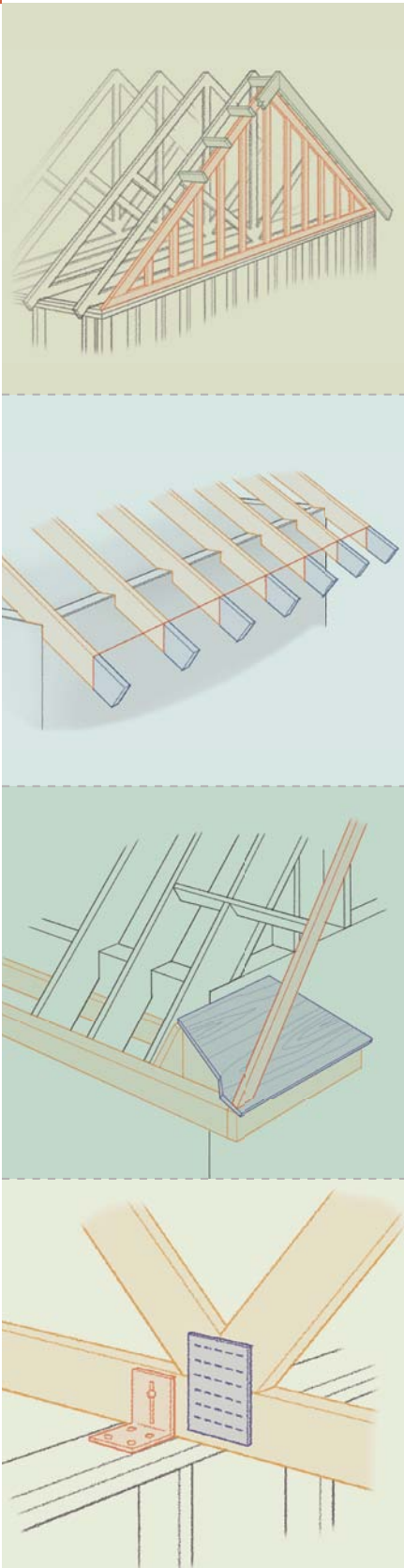

Framing Roofs 2: Trusses, Eaves, Rakes, and Sheathing

ABOUT TWO-THIRDS OF THE RESIDENTIAL ROOFS in America are built with manufactured trusses. In many ways, trusses simplify roof construction. You don't have to calculate lengths or lay out angles, and for the most part cutting is not permitted. Only cutting the tails, which are outside the bearing points, is permitted. Trusses are prefabricated assemblies that you install on common layout intervals. Installation can be very fast; experienced crews can often set the trusses for a house in a few hours.

Yet, it's easy to oversimplify the installation process. Trusses are an engineered lumber product, and, like all engineered lumber products, they are part of an engineered system. It's essential to understand how trussed-roof systems work and why truss designers specify the details of the specific system you're working with. It's also important to understand how to store, move, and handle trusses. Once set and braced, trusses have tremendous strength, but they can be damaged if they aren't properly cared for prior to the installation.

The first part of this chapter deals with the entire process of building with roof trusses, from ordering the truss package to setting and bracing the trusses. The second part focuses on the work that follows the installation of rafters or trusses, namely finishing the rakes and eaves. The basic construction of these elements is the same whether the roof is stick-built or trussed.

The final topic of this chapter is the installation of the sheathing on the finished roof frame. As with eaves and rakes, this job is essentially the same whether the frame has been built with rafters or trusses.

Trusses

Although heavy timber trusses have been around for centuries, modern, pre-engineered trusses, which are made from light dimensional lumber and connected by steel plates, came into being in 1952. In that year, A. Carroll Sanford invented and patented the metal plate-connected engineered wood truss.

Sanford's light manufactured trusses worked well with platform-framed houses. They also helped overcome the problem of a shortage of skilled carpenters following World War II because trusses eliminated the complicated layout required for stick-built roofs. And, unlike the heavy timber-frame trusses that preceded them, these metal plate-connected trusses were light enough to be lifted in place by the framing crew. This was a major advantage in the days before portable cranes and telehandlers were widely available.

The Beauty of a Triangle

A truss is essentially a framework of triangles held together by metal plates. Triangles are inherently rigid; unlike rectangles and other polygons, it's impossible to alter the shape of a triangle without changing the length of one of its sides.

The size and configuration of the triangles, the grade and species of the wood, and the strength of the connecting plates are essential elements of the design. These are the concerns of the companies that design and manufacture the trusses, however. Your job is to store, handle, and install them in a manner that doesn't compromise their structural integrity. This boils down to preserving the strength and rigidity of the triangles that make up the trusses.



Heavy timber truss

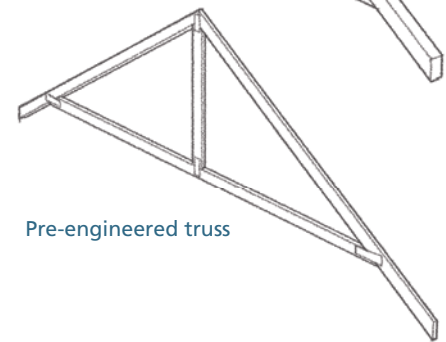

Pre-engineered truss

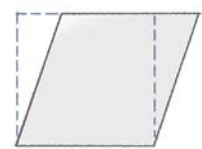
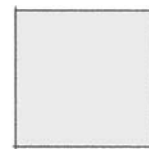

Rectangles and other polygons can change shape even when the lengths of the sides remain fixed.



The shape of a triangle can't change unless the length of one of its sides changes, and that's the key to truss design.

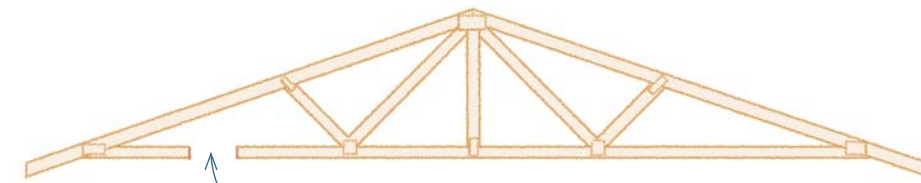

Never cut or alter a truss.

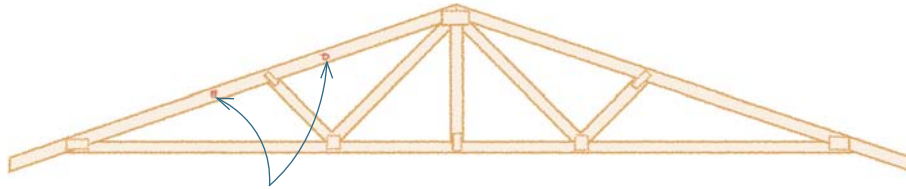

Except for pilot holes for nails, never drill into a truss.

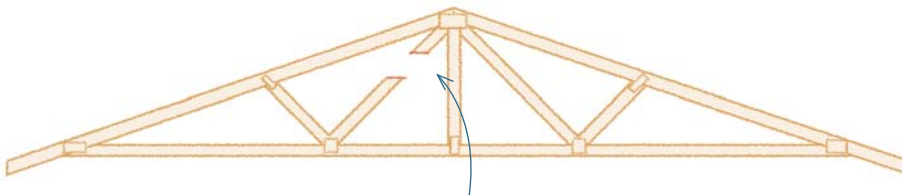

If one triangle in a truss is weakened, the entire truss is compromised. If you need to alter a truss, always consult the truss designer first. Building codes require documentation for any alterations.

WAYS OF WORKING

Engineering, Oversight, and Governing Organizations

One of the major benefits of metal plate-connected trusses is quality control. Prior to the invention of the metal plate truss connector, carpenters sometimes built trusses on site using solid wood or plywood gusset plates. The engineering for these trusses consisted of guesswork on the part of the carpenters and, not surprisingly, the connections sometimes failed. Site-built trusses are not permitted in today's building codes.

As the truss industry grew, two governing organizations emerged to provide engineering standards and oversight. These organizations, the Truss Plate Institute (established in 1960) and the Wood Truss Council of America (established in 1983), provide the standards for building trusses throughout America. In addition to guiding and regulating the design and manufacture of trusses, these organizations offer guidance to carpenters who install them.

Truss Options

Trusses can be made for spans in excess of 50 ft. and, thanks to computers, packages for all common roof shapes can be designed and built quickly and precisely.

● GABLE-END TRUSSES

Strictly speaking, gable-end “trusses” are not trusses. They are frames built in the shape of the other trusses in a package. Instead of a series of interlocking triangles, they have vertical pieces set at intervals of 16 in. or 24 in. for attaching sheathing and siding. However, this configuration gives the gable frame little tensile strength and it must rest on the end wall of the house. Using gable-end trusses saves time by eliminating the need to frame a gable-end wall.

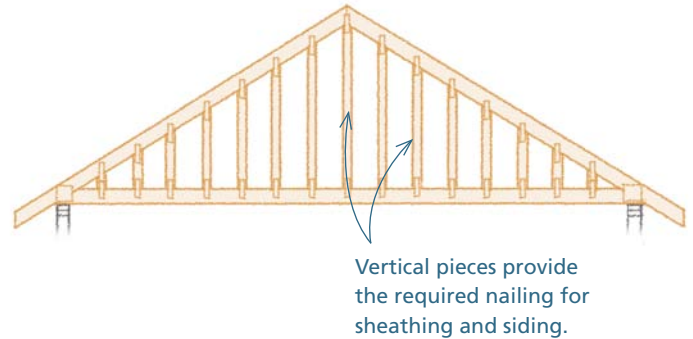

● DROP-TOP GABLE-END TRUSS

Where rake overhangs are planned, truss suppliers can fabricate drop-top gable-end trusses. These are dropped the width of the top chord (usually 3½ in.) from the common trusses in the package. After you set all the trusses, you can install a rake that passes over the drop-top truss and ties into the first truss inside the wall.

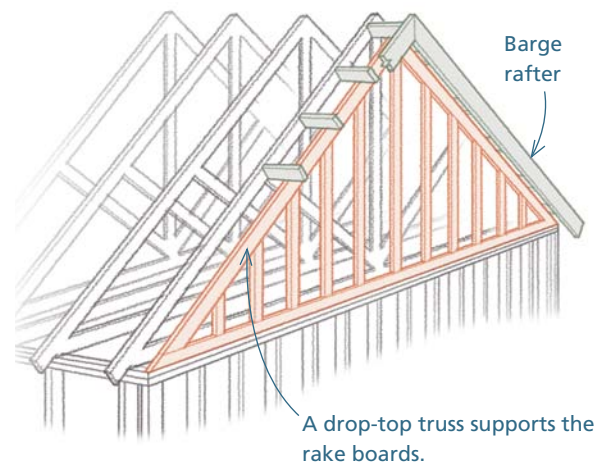

● SCISSOR TRUSSES

Scissor trusses are used to construct cathedral ceilings in rooms with wide spans between bearing walls. Because these trusses exert no thrusting force on the walls, horizontal restraints, such as exposed beams or cables, are not necessary.

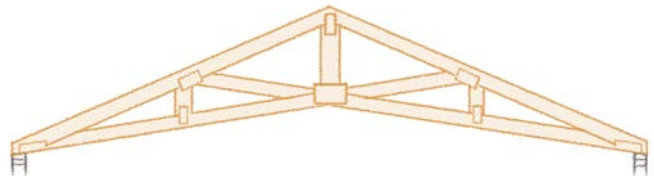

● ATTIC TRUSSES

Attic trusses are designed with open spaces above the bottom chord that can be used for storage or for living space.

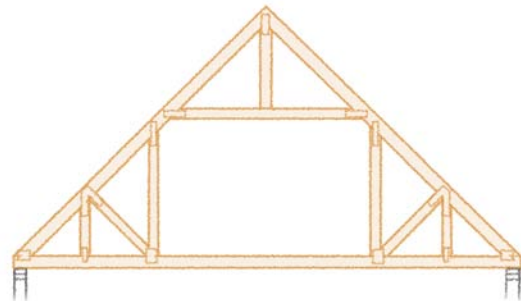

● CANTILEVER TRUSSES

To support the roof over a porch without using posts, designers sometimes specify cantilever trusses.

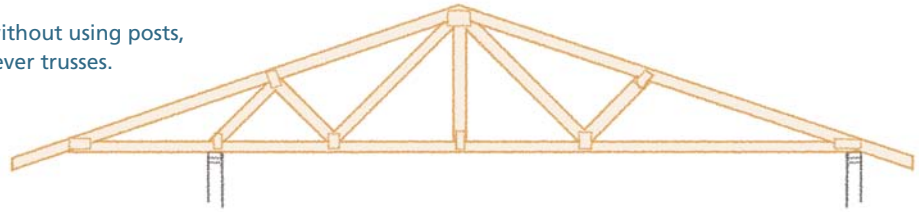

● VALLEY TRUSSES

When a house has one section running perpendicular to another, the intersecting roofs form valleys. To build these valleys with trusses, you run the first roof frame straight through the main section of the house. After sheathing the main house, use step-down valley trusses to build the intersection are on top of the roof deck.

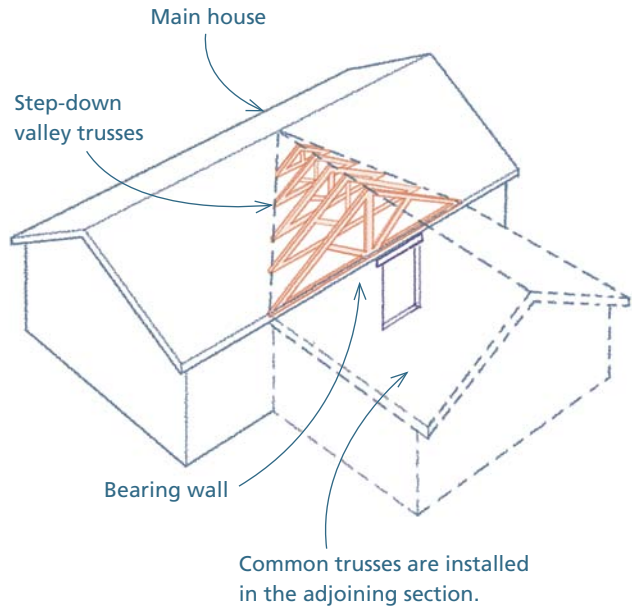

● GIRDER TRUSSES

On some houses, valley trusses are used in conjunction with girder trusses to create a wide opening between the main house and the intersection wing.

Girder trusses are typically made from several trusses that are fastened together on site. Because these multi-ply trusses support a huge amount of weight, they should never be designed on site. The trusses and the mechanical fasteners used to tie them together must be specified by the truss fabricator.

On these houses, the girder trusses are set first, extending across the opening to the intersecting wing. Then, when the trusses from the main rectangle of the house are set, the ends adjacent to the wing are supported by metal hangers affixed to the girder truss.

After the common trusses are set, valley trusses are installed on top of them to form the valleys.

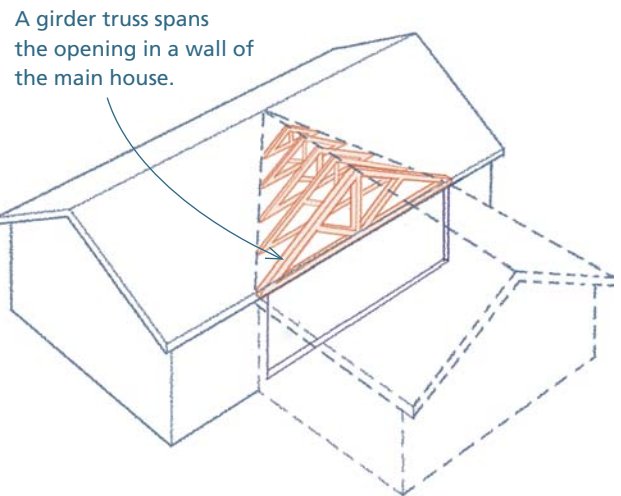

A girder truss supports both the main roof and the valley trusses in this area.

● HIP TRUSSES

Girder trusses are also used for hip roof packages. After setting the girder truss a specified distance from the corner, hip jack trusses and end jack trusses are attached to the girder truss with metal hangers.

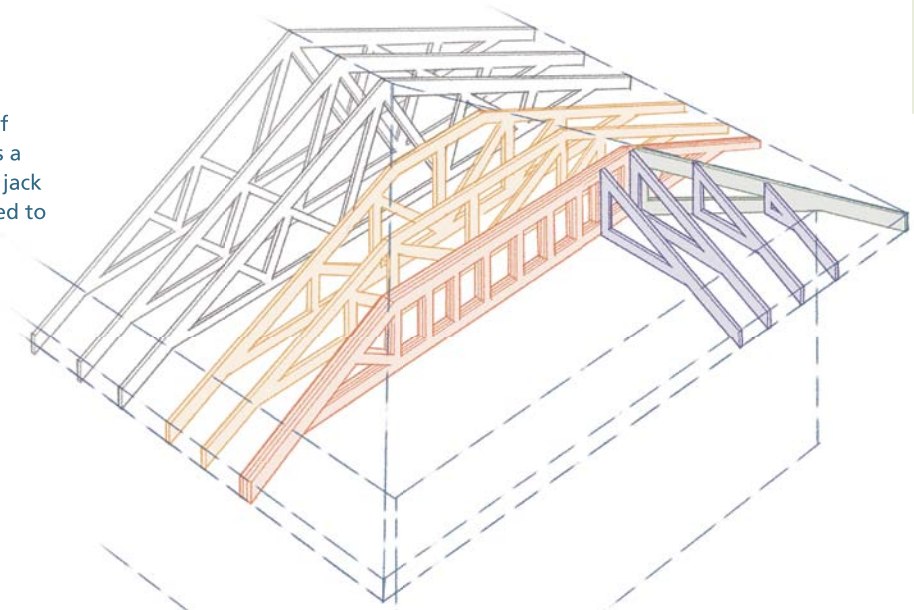

● MASTER AND SPLIT TRUSSES

When the plan calls for a large framed opening in the roof, as would be required for many chimneys and skylights, truss designers use master and split trusses. The master trusses work like trimmer rafters, carrying the weight of the framing below and above the opening. Like girder trusses, master trusses are often made up of multiple plies of trusses fastened together on site.

The top and bottom of the opening are made from header trusses attached to the master trusses with metal hangers. Split trusses are then attached to the header trusses to fill above and below the opening.

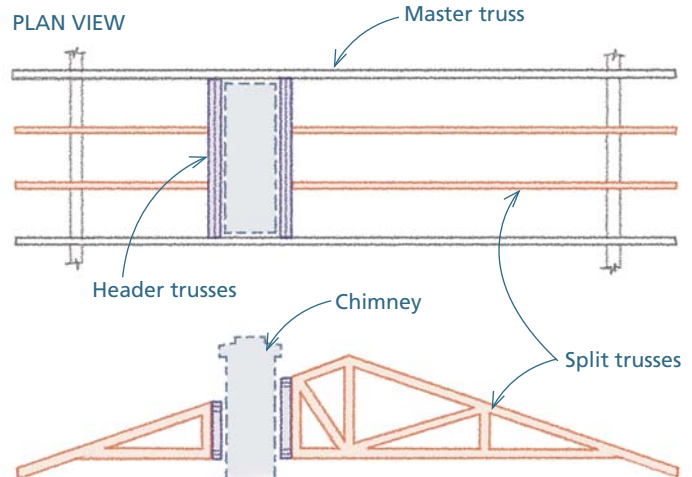

● OTHER SHAPES

Trusses can be made for a variety of roof styles, including dual-pitched, gambrel, and mansard roofs.

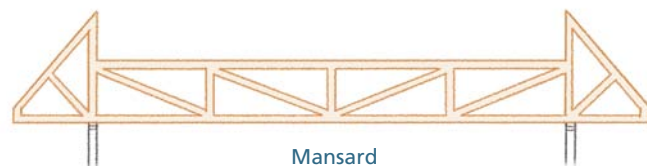
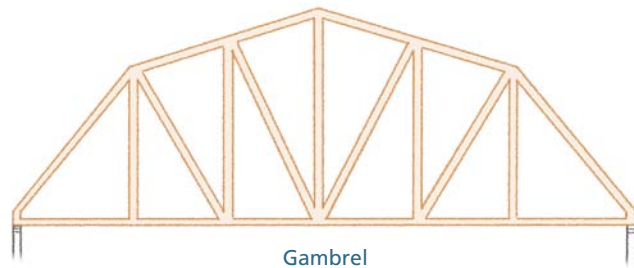
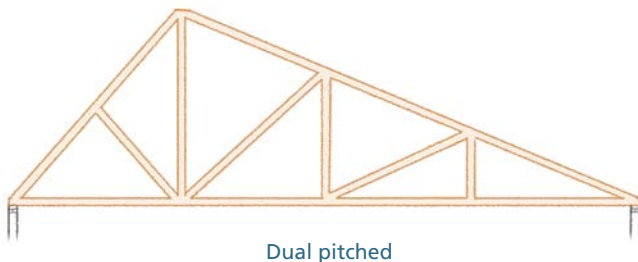

Ordering Trusses

Typically, truss fabricators sell through building suppliers. For simple gable roofs on rectangular buildings, you and the building-supply salesman can supply the necessary data. You will have to provide the width of the building, the desired pitch, the width of the eaves, and your gable-end preferences.

The truss designer works with assumptions about live and dead loads. In most cases, he'll be familiar with the live loads in your area and he'll use dead load assumptions based on common building materials and practices.

If you plan to use an unusually heavy roofing material, such as slate; plan to place extra loads on the roof, such as air-conditioning equipment; or if you're building a more involved roof, you usually have to provide

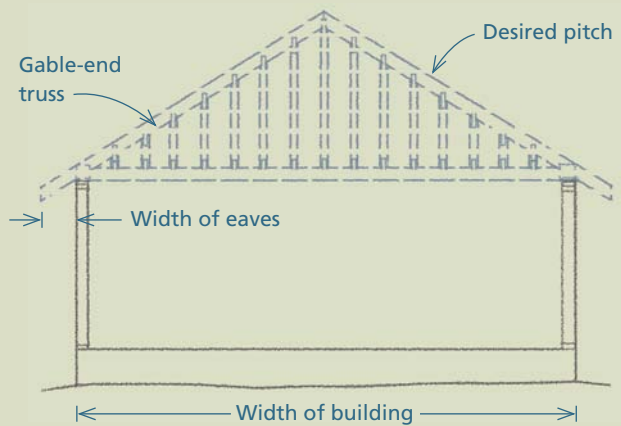

your supplier with a copy of the plans. The supplier, in turn, will submit a copy of the plans to the truss manufacturer. The truss designer uses the plans to develop an engineered plan for the trusses. When the trusses arrive, they'll have a copy of the truss design drawings attached.

Storing and Handling Trusses

There are two basic rules for storing and handling trusses: Keep them straight and keep them dry. Trusses have great strength when pressure is applied parallel to their depth. They are weak and flexible, however, when forces are applied perpendicular to their depth. Excessive bending can loosen connections and jeopardize the structural integrity of the truss. Store banded truss packages on edge, if possible (to keep them from falling over, you may need to use braces). In general, follow these guidelines:

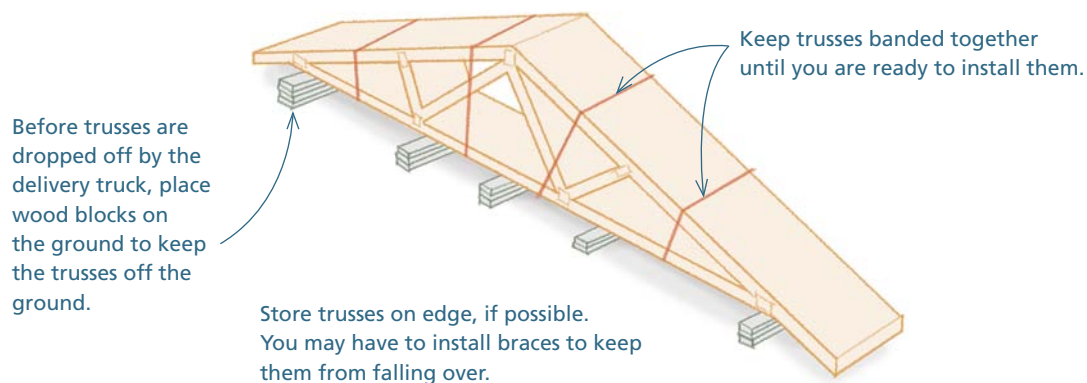

SAFETY FIRST

Watch Out When Unbanding Truss Packages

.....

When you cut the bands holding the truss package together, the band can spring out unpredictably and present a serious cutting hazard. Wear gloves and eye protection, and don't position yourself in line with the band.

Another hazard is the way the trusses fall when you cut the band. Before you cut the band, set the package on its side and either position yourself on top of the package or uphill from the package. And make sure you have a clear route to escape the trusses in the event that they start sliding toward you.

.....

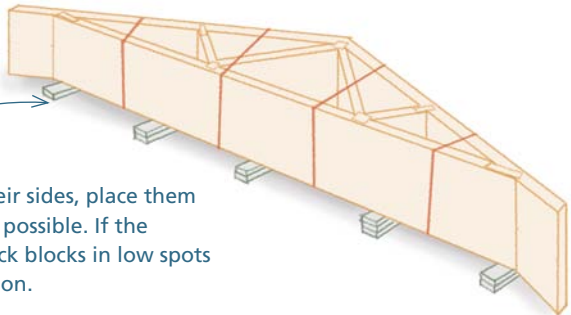

To store trusses on their sides, place them on as flat a surface as possible. If the ground is uneven, stack blocks in low spots for the trusses to rest on.

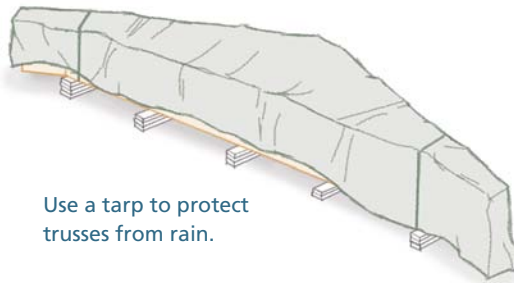

Use a tarp to protect trusses from rain.

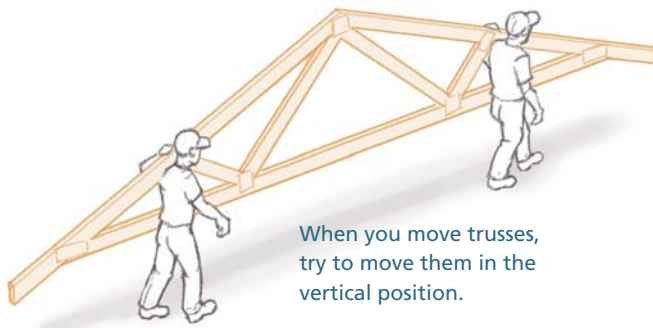

When you move trusses, try to move them in the vertical position.

If you're moving large trusses by hand, it's sometimes necessary to carry them in the flat position. In these cases, station some members of the crew near the center to keep the truss from bending too much.

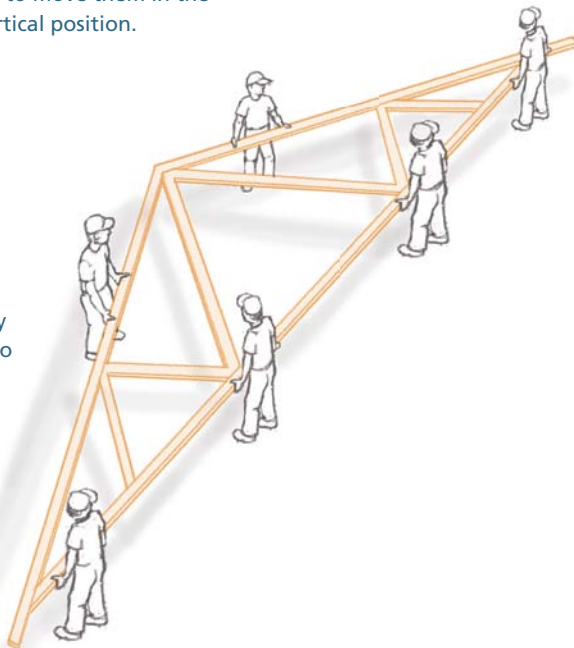

Moving and Hoisting Trusses

On most houses, a carpentry crew can move and hoist the trusses by hand. For the last 25 years or so, however, carpenters have been able to hire portable cranes to lift the trusses. And, today, production framing crews often invest in telehandlers (telescoping forklifts), which are capable of hoisting trusses for most houses.

Use the same procedure as you would for rafter locations (see chapter 3). Although the procedure is essentially the same, spacing for trusses is usually 24 in. on center, as opposed to the 16-in. intervals common for rafters.

● SETTING TRUSSES BY HAND

When you install trusses by hand, lift one end at a time over the bearing walls. If possible, keep the truss vertical, with the apex of the truss pointed down. With the ends overlapping the walls, rotate the truss into the upright position. Use one or two forked push sticks made out of 2x4s to finish rotating the truss above ceiling level. If the span is less than 20 ft., you can use one push stick close to the center of the top chord. If the span is more than 20 ft., you should use two push sticks placed under the top chord about one-third of the way down from the apex. Make sure a crew member is stationed at the top to catch the truss as it is rotated into the upright position.

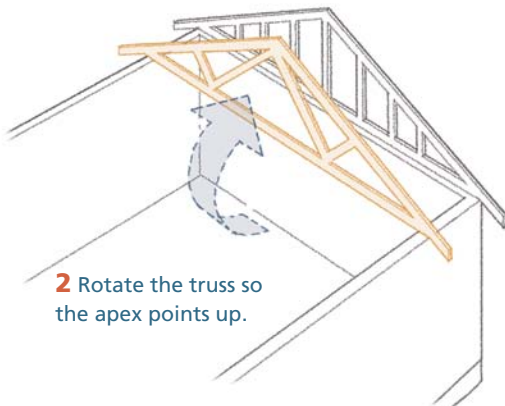
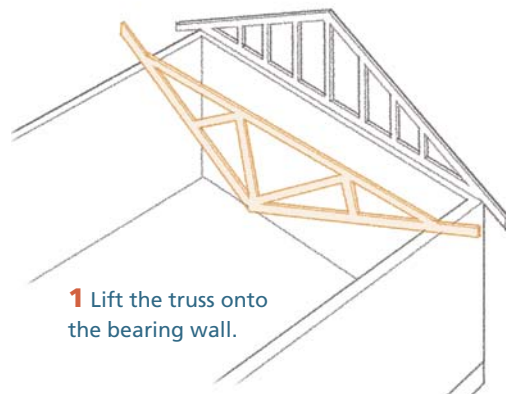

● SETTING TRUSSES WITH A CRANE

For spans 30 ft. or less, attach the sling of the crane at two points near the first web/top chord intersection down from the apex of the truss. For spans longer than 30 ft., use a spreader bar and three points of attachment.

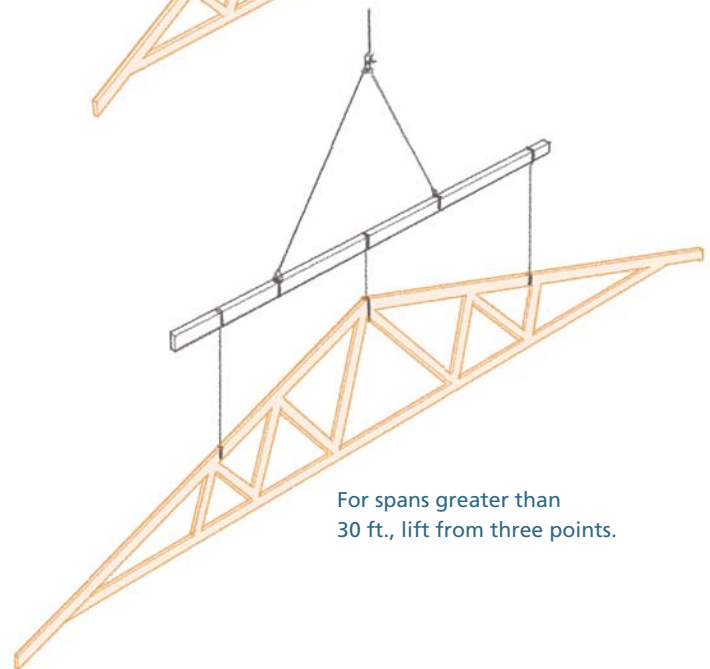
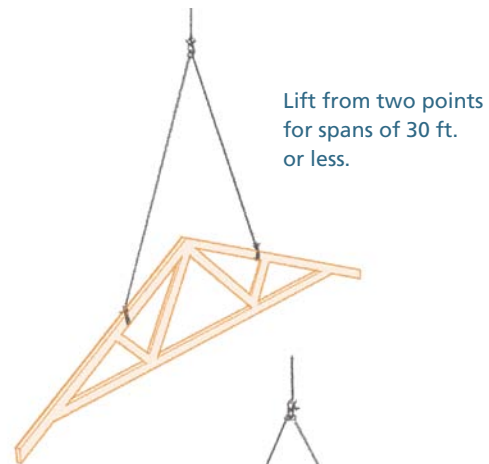

Aligning Trusses

It's important to line up trusses precisely as you install them. When the trusses are not aligned accurately, the roof ends up with a crooked ridge and unsightly dips and humps in the deck. There are a few approaches to aligning trusses as you install them.

● SETTING TRUSSES BY HAND

If you're installing the trusses by hand, you can set up a string in the center of the span and set the apex of each truss to the string. A simple way to do this is to install a truss at each end of the house, then run a string from the apex of one truss to the apex of the other.

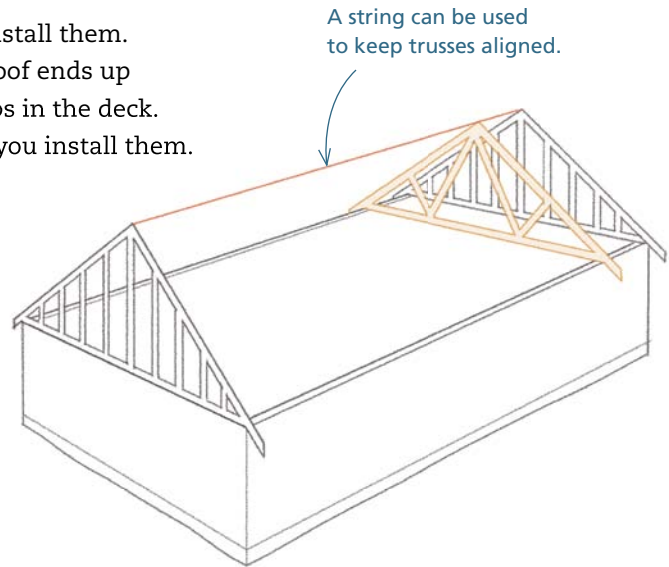

● SETTING TRUSSES WITH A CRANE OR TELEHANDLER

If you're using a crane or a telehandler, the string would get in the way as you lower the truss into place. In these cases, mark the bottom chord of the truss where it will meet the inside of one of the walls before you hoist the truss.

First, mark the center of the bottom chord. From the center point, measure and mark one-half the span (the distance between the bearing walls). When you set each truss, line up this mark with the inside of the wall before you install it.

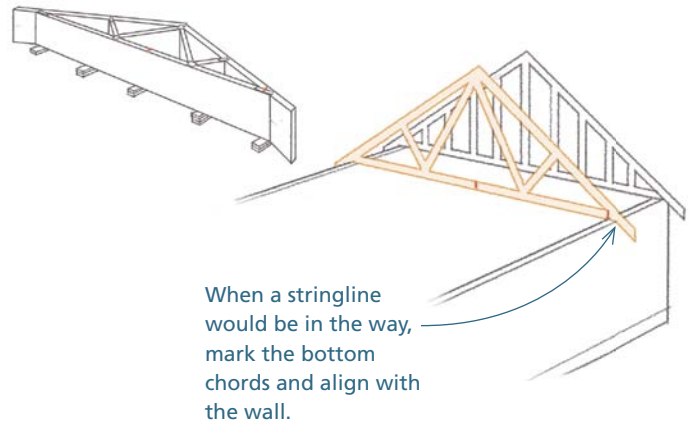

● USING A LASER LEVEL

Another approach is to use a laser level rather than a string. Set it up at one end of the house so that it shoots a level line just below the apex of the first truss installed. Before hoisting each truss, use a felt-tipped pen to draw a plumb line down from the apex. When the dot or line from the laser strikes the plumb line, the truss is aligned and can be installed.

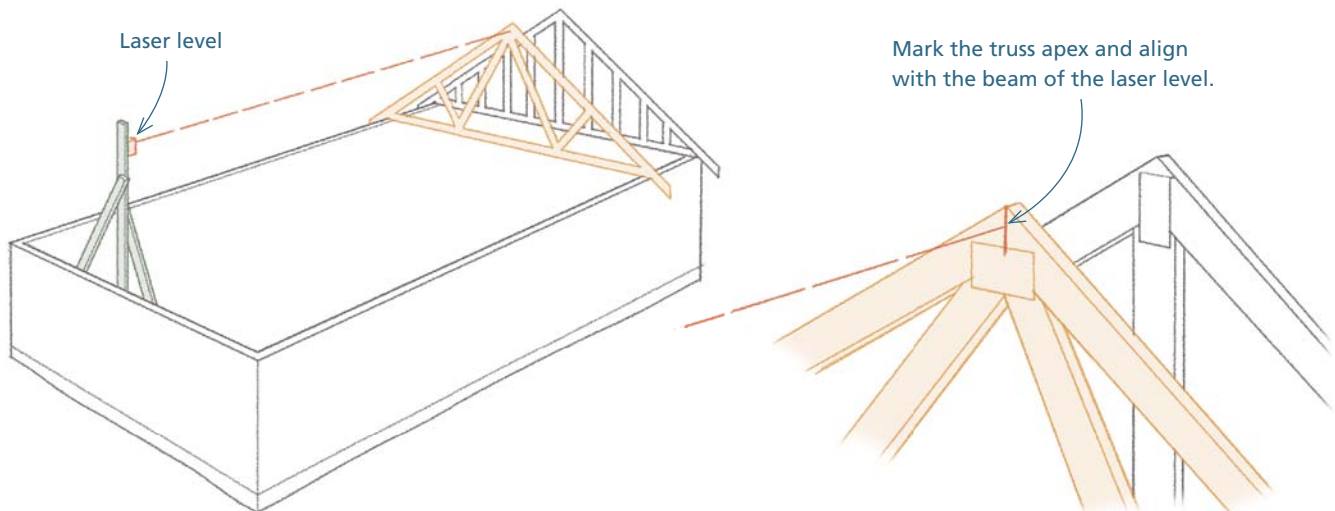

Three Kinds of Braces

Braces are essential to truss roofs. During the installation, temporary braces hold the trusses straight and keep them from toppling over. After the installation is complete, permanent braces tie the trusses together and hold them rigidly in place. Braces are divided into three distinct categories: ground braces, temporary truss braces, and permanent truss braces.

Ground braces

Ground braces are used to hold the first truss in a line of trusses in place. The advantage of setting the braces to the exterior of the house is that they're not in the way of subsequent trusses. The bottoms of these braces are either anchored to stakes driven into the ground (hence the term ground brace) or to the floor of the house. The ground braces have to be strong enough to hold the first truss rigidly in the correct position as well as hold the

subsequent trusses that are tied to the first one. Because of their length, ground braces often have to be built with two pieces of lumber. Near the center of these built-up braces, you should add braces extending back to the base of the frame. The ground braces also have to be braced laterally to keep them from buckling.

On one-story buildings, where the first floor is close to the ground, you can brace the first truss to stakes driven into the ground.

On two-story houses, on buildings with high foundations, and on houses with exterior grades that slope rapidly away from the foundation, exterior ground braces are not practical. In these cases, it's easier to use interior ground braces that are tied to the floor.

Because these interior braces interfere with the subsequent trusses, the first truss can't be placed at the end of the house. Install the first truss near the center of the house and brace it straight, plumb, and in-plane. After installing and bracing the first half of the trusses, you can remove the ground bracing and install the trusses on that side of the house.

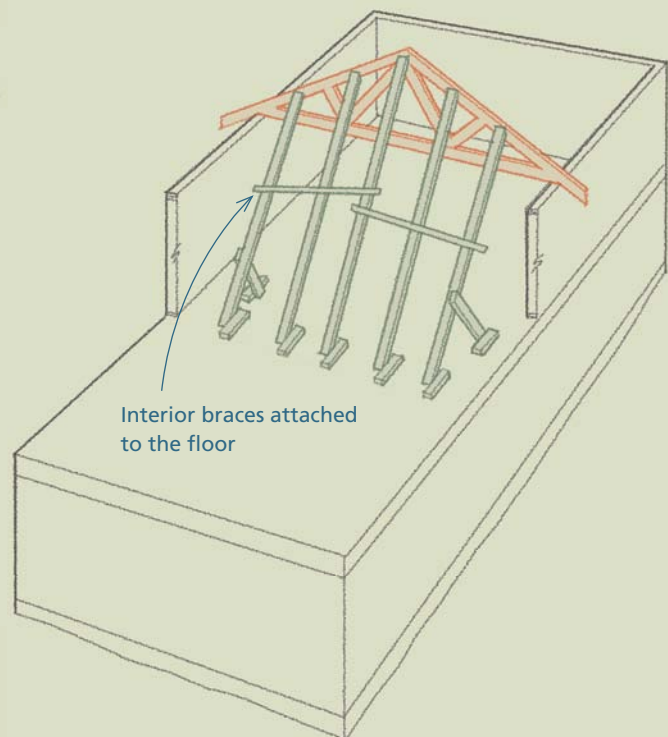
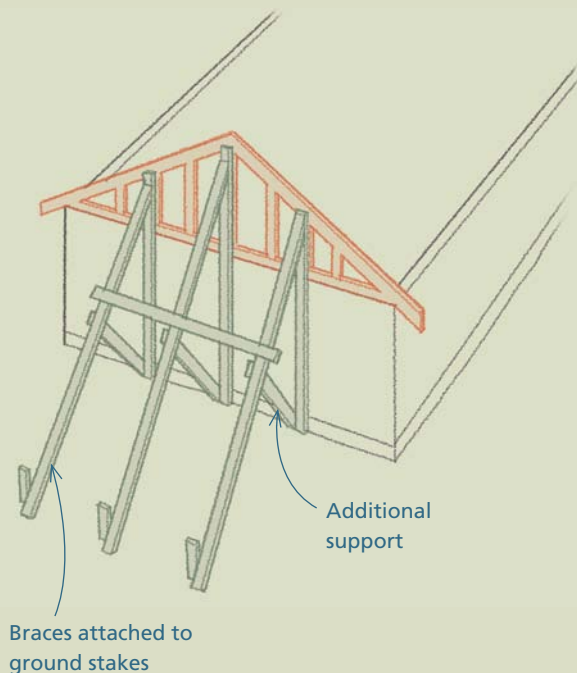

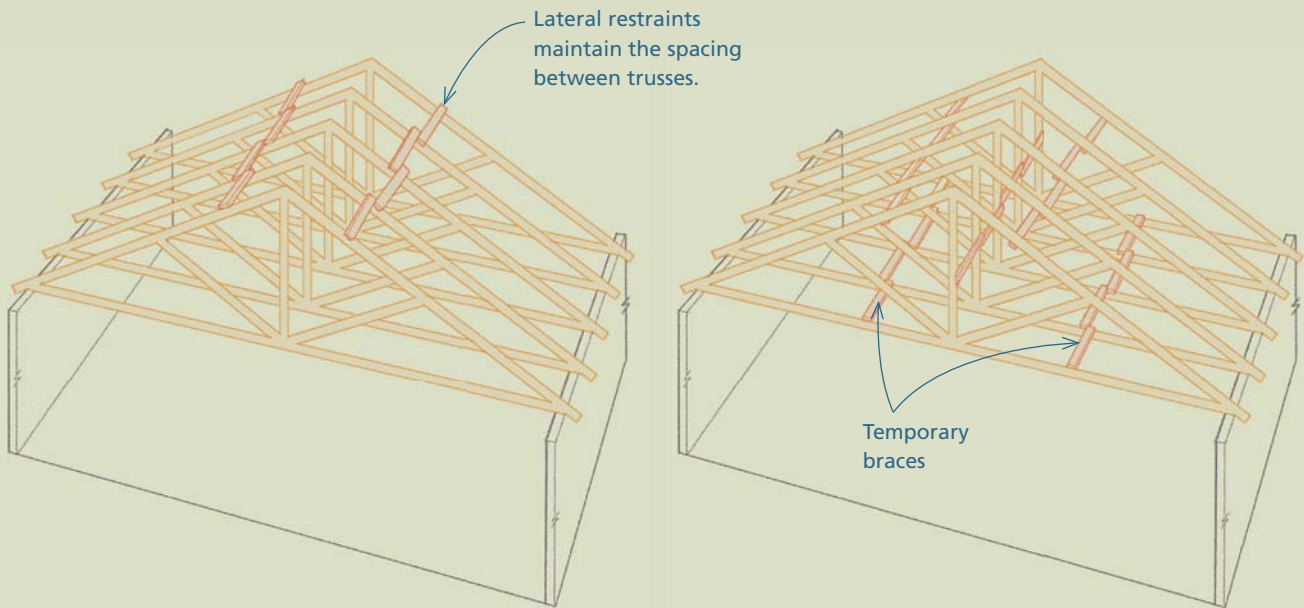

Temporary truss braces

After securing the first truss with ground braces, subsequent trusses are tied to the first truss with temporary bracing and lateral restraints. The lateral restraints are used to keep the spacing between the trusses correct; the braces hold the trusses safely in the upright position during the installation.

Inadequate bracing during the setting of trusses is a serious safety hazard. A network of diagonal braces and lateral restraints, installed inside the truss system, is essential for both a safe and accurate installation.

Permanent truss braces

Temporary bracing has to be followed by permanent bracing that becomes part of the permanent structure. This two-part bracing procedure, however, is not always essential. With careful planning, much of the bracing used during the truss installation can be left for permanent bracing. The truss bracing requirements are usually specified in either the approved plan or in the truss design drawings that come with the truss package.

Materials for truss bracing

The material for truss bracing varies. Temporary bracing is usually composed of 2x4 lumber connected with 12d to 16d nails. The nails should be driven tight, so if you plan to remove the bracing, you can make the job easier by using double-headed nails.

Metal braces and restraints, designed specifically for truss installation, also are used for both temporary and permanent bracing.

Materials for permanent bracing include 2x4 lumber and structural panel materials, such as plywood and oriented strand board (OSB). Finally, the materials that cover the frame—roof sheathing and ceiling drywall—are considered permanent bracing materials.

Building a Gable Roof with Trusses

This section uses the example of a simple gable roof to show the basics of framing roofs with trusses. Once these principles are mastered, they can be applied to just about any trussed roof. In this example, the locations of the trusses are already marked on the walls.

The goal of installing a trussed roof is to set each truss straight, plumb, and in-plane over its length. In this position, where the triangles of the truss line up with the force of gravity and with each other, the truss is working at its optimal strength.

To get all the trusses straight, plumb, and in-plane, install the first truss precisely and then use it as a reference for the rest of the trusses. Once you have the first truss securely braced straight and plumb, you can transfer those attributes to the rest of the trusses by bracing them in precise increments (usually 24 in.) away from the first truss.

STEP 1 Set the first truss

- 1 Lift or hoist the first truss in place on the walls using the techniques described earlier.
- 2 Attach the truss to the top plates of the walls. (For more on attaching the trusses to the wall, see “Anchoring Rafters and Trusses to Walls” on p. 156.)
- 3 Brace the truss straight and plumb.

STEP 2 Establish a system for aligning the trusses

- 1 Since you’re setting these trusses by hand, use a string to align the trusses.
- 2 Set and brace a second truss at the far end of the house. The bracing here does not have to be as extensive as that installed on the first truss because this truss will not support the subsequent trusses.
- 3 Set up a string that extends from the apex of the first truss to the apex of the second truss.

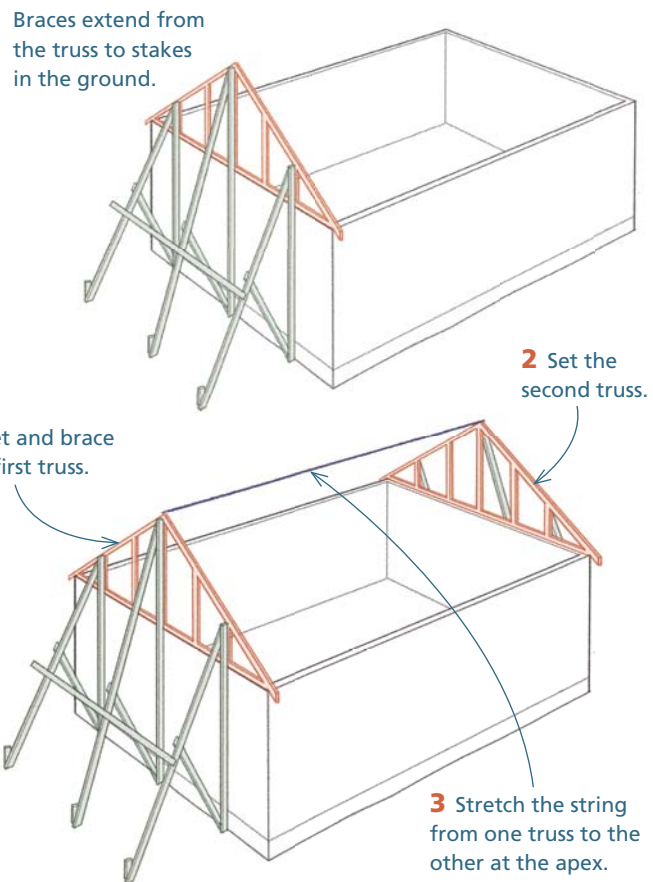

STEP 3 Set subsequent trusses

Set the next truss on the walls, and move it until the apex is aligned with the string and on the layouts marked on the walls. Pre-drill and toenail it to the walls. To hold the truss upright, use a 2x4 block of wood that's nailed on the top of the top chord and tied to the first truss.

STEP 4 Add restraints

After setting three or four trusses in this manner, begin installing lateral restraints. Set these in horizontal lines perpendicular to the trusses. They should line up with the ground braces and, in most cases, be 10 ft. or less apart. Use the lateral restraints to set the top chords of each rafter the proper distance away from the top chord of the first rafter. These distances should be identical to the layout on the bearing walls (which is 24 in. on center in this example). You can mark the layout directly on the lateral restraints, then move the top chords of the trusses to the layout as you nail on the restraint. On large roofs, use diagonal braces along with the lateral restraints to provide added rigidity.

• BRACE AS YOU GO

Install temporary bracing in the web and bottom chord planes as directed by instructions that come with the trusses. In this example, the web bracing is made up of lateral restraints combined with diagonal braces. To prevent a domino-like collapse, don't wait until all the trusses have been set. Braces and restraints should be installed as you set the trusses.

STEP 5 Begin planning for eaves and rakes

On some roofs, you can postpone work on the eaves and rakes until later. On complex roofs, it may make sense to build eaves and rakes before installing the sheathing. On most simple roofs, however, carpenters follow a middle ground in which they cut the rafter tails and install a subfascia but leave most of the framing for the eaves and rakes for later. (For more on cutting the tails in place, see "Framing Eaves" on p. 157.)

1 Move the truss on the walls until the apex lines up with the string.

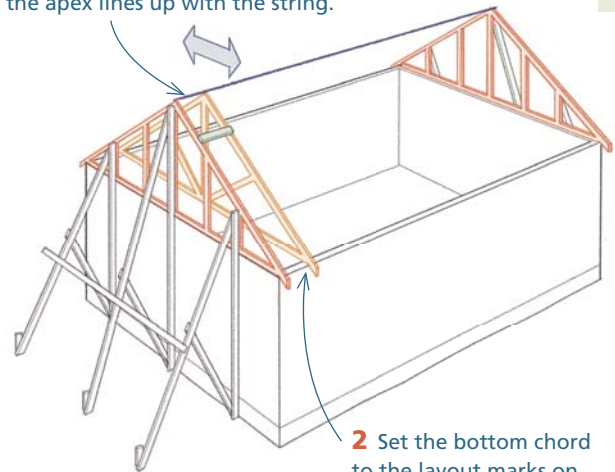

2 Set the bottom chord to the layout marks on the top plates.

Lateral restraints

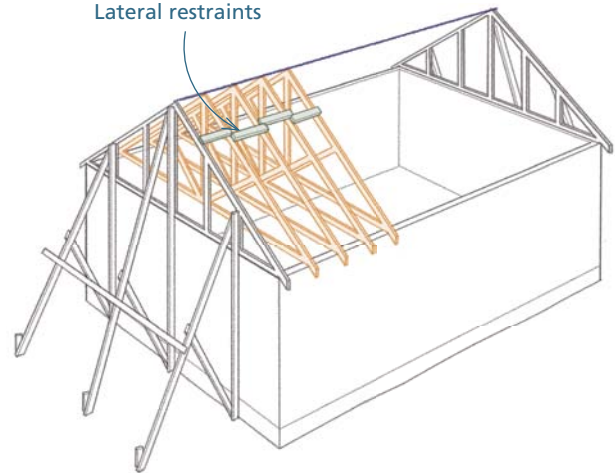

Diagonal braces stiffen the assembly.

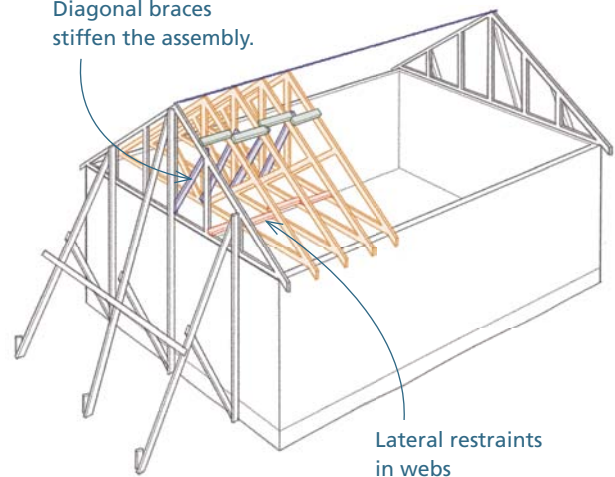

Lateral restraints in webs

Anchoring Rafters and Trusses to Walls

Whether you build a roof system with rafters or trusses, it must be tied securely to the bearing walls. The structural demands for this connection vary according to the design loads in your area.

Toenails

The most common way to attach rafters and trusses to bearing walls is with toenails. Use three 12d or 16d nails at each connection. Drive two nails in from one side and the third into the center of the wall from the other side. To avoid splitting the wood, predrill with a 1/8-in.-dia. hole.

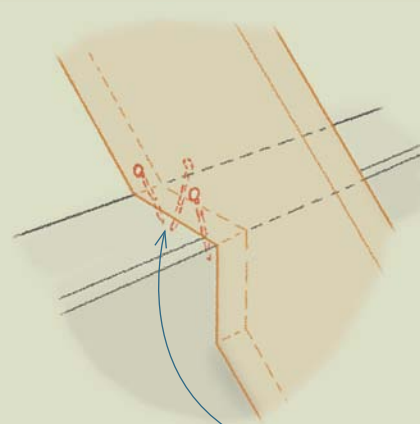

Toenail the truss to the bearing walls.

Metal rafter/truss ties

Metal ties are required by building codes where high winds can be expected. You can confer with the building inspector and with customer support at the manufacturer to find out which type of tie to use. In many cases, you can initially install the rafters or trusses with toenails, and then come back later to install the metal connectors. Always use the nails specified by the manufacturer to attach the connectors.

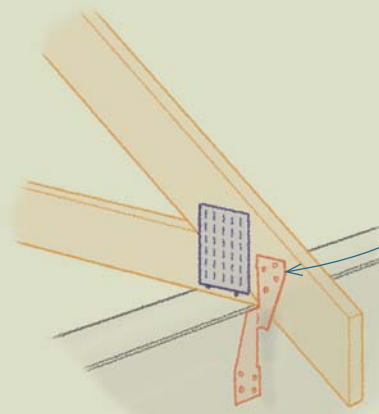

Local code may require metal connectors.

Slotted truss anchors

At midspan walls, trusses should not be rigidly anchored to walls. To accommodate slight movement in the trusses yet hold interior walls in place, slotted anchors are recommended instead. Slotted anchors are particularly important with scissor trusses.

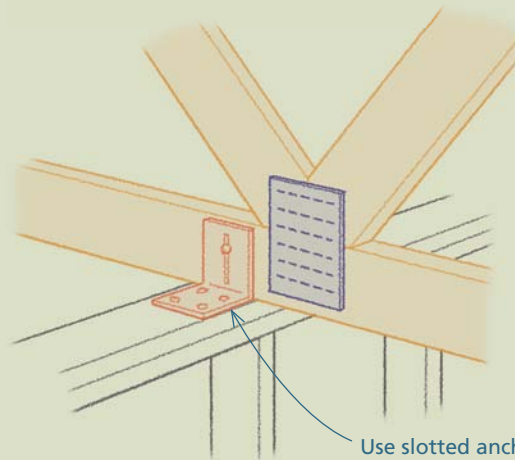

Use slotted anchors at midspan walls.

STEP 6 Install the sheathing

Gradually remove the temporary bracing and restraints on the top chord plane of the trusses and install the sheathing. Use the techniques described in “Installing Roof Sheathing” on p. 177. In this example, a ladder-type rake is planned. Leave the sheathing long at both ends of the house. You can cut the sheathing and build the rake later. (For more on building the rake, see “Framing Rake Overhangs” on p. 164.)

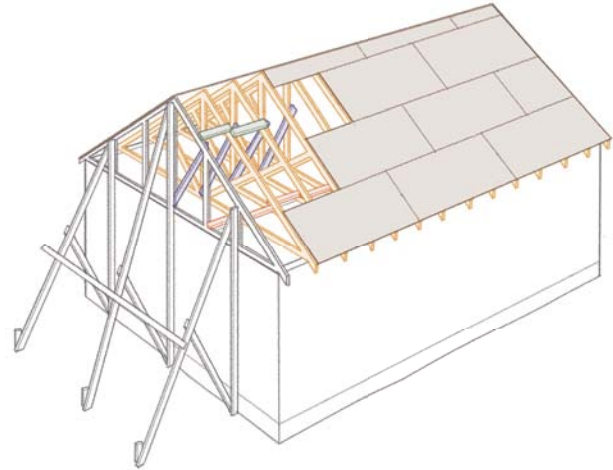

Framing Eaves

There are several ways to frame roof overhangs. Here, we'll look at framing eaves and then, in the next section, at framing rakes. The design of the eaves is influenced by the budget of the job, the width of the eave, whether the house will have an overhanging rake, and the personal preferences of the carpenter doing the work. The following discussion focuses on the best techniques for building wide eaves on houses that also have wide rake overhangs.

Precut Rafter and Truss Tails

The procedure for laying out and cutting rafter tails is discussed in chapter 3 (p. 113). If the roof is built with trusses, the trusses can be ordered with precut tails. With either rafters or trusses, you should expect to make some adjustments to the tails when you build the eaves. Because wood is not dimensionally stable, the ends of the tails almost never line up perfectly after the rafters or trusses are installed. To get the ends of the tails in line, follow these steps:

TOP TIP

Use Your Rafter Jig

.....
 If you've fabricated a rafter jig, it pays dividends when you frame eaves, rakes, gable ends, and returns. Not only can you use it to lay out plumb and level cuts, but if you've written the pertinent information on the jig, you can also refer to it to find the angle of the pitch in degrees and the dimensions of the base-1 triangle.

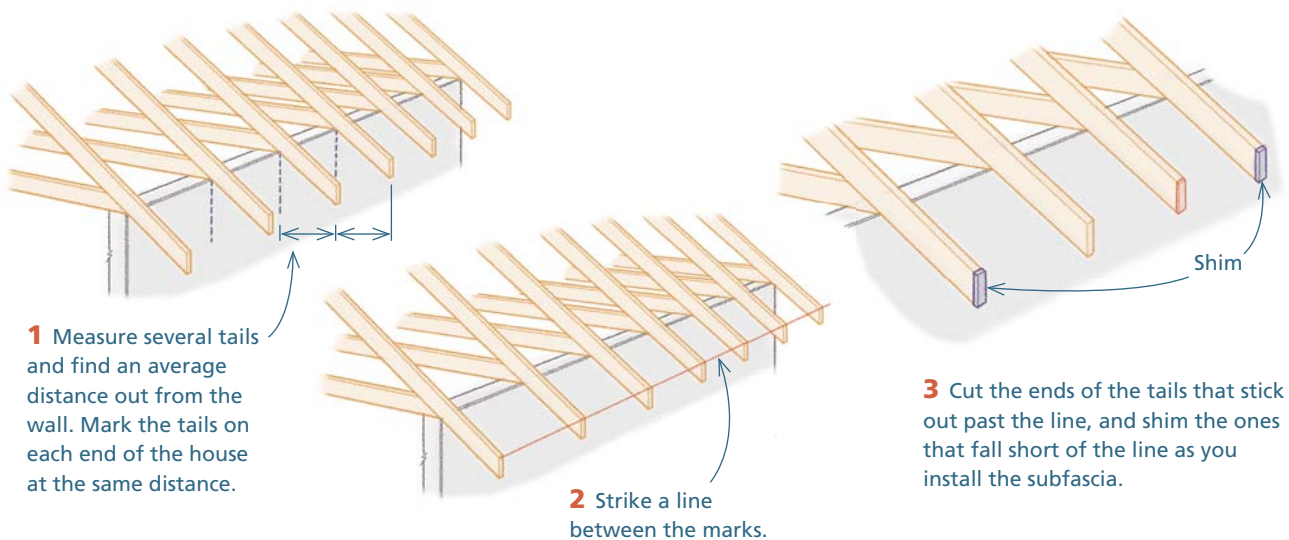

1 Measure several tails and find an average distance out from the wall. Mark the tails on each end of the house at the same distance.

2 Strike a line between the marks.

3 Cut the ends of the tails that stick out past the line, and shim the ones that fall short of the line as you install the subfascia.

Cutting Tails in Place

Since some cutting and shimming is usually necessary, many carpenters don't worry about cutting the tails until after the rafters or trusses are installed. Here's how to lay out and cut the tails:

STEP 1 Lay out the end of the first tail

Select any tail to draw the layout on. After deciding the width that you want to make the eave, measure that distance out from the face of the bearing wall. In this example, the width of the finished eave is 24 in. from the finish materials that will be added to the wall.

STEP 2 Lay out the bottom of the first tail

3 Cut along a level line that's even with the bottom of the subfascia.

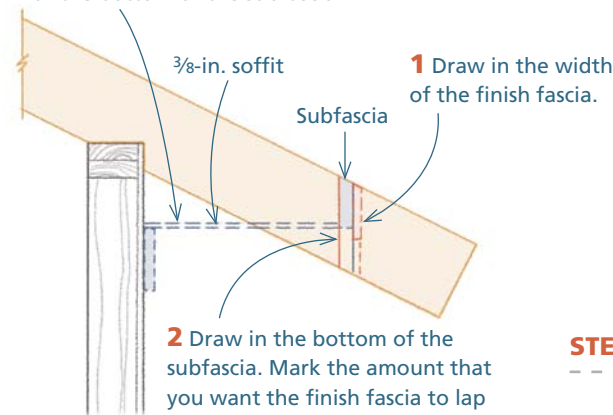

2 Draw in the bottom of the subfascia. Mark the amount that you want the finish fascia to lap over the soffit of the eave (1 in., in this example). Next, draw in the thickness of the soffit material (3/8-in. plywood here). The bottom of the subfascia is at the level of the top of the soffit plywood.

1 Scribe a plumb line indicating the outside face of the finish fascia.
2 Measure and mark the thickness of the finish fascia, and draw a second plumb line.
3 Measure and mark the thickness of the subfascia, and draw a third plumb line.

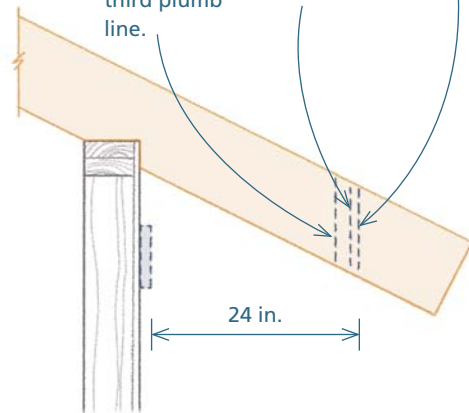

The subfascia will be nailed to the rafter tail. The end of the tail, therefore, should be cut along the third vertical line.

STEP 3 Mark the ends of the rest of the tails

2 Mark the tops of the end rafters/trusses at the layout, then snap a chalkline across the tops of the tails between the two marks.

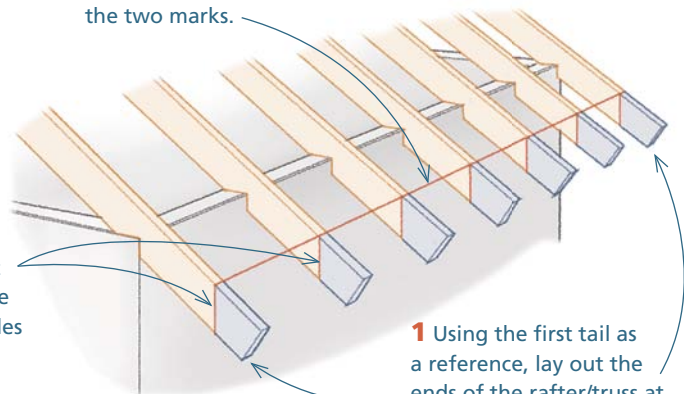

3 From the marks left by the chalkline, scribe plumb lines on the sides of the tails. Cut along the plumb lines.

1 Using the first tail as a reference, lay out the ends of the rafter/truss at each end of the eave.

ESSENTIAL SKILLS

Don't Let the Kerf Close

When you cut the end of a rafter tail, gravity pulls the offcut down. If you cut from the top, the offcut falls harmlessly down and away from the spinning blade. If you cut from the bottom up, on the other hand, the kerf closes as the offcut begins to fall. At the least, this creates an alarming screech, and sometimes the offcut is flung by the spinning blade. At the worst, the closing kerf can bind on the sawblade, causing the saw to kick back.

If at all possible, cut from the top down. If this is impractical, find a way to support the offcut while you make the cut. One way to do this is to screw or clamp a block of 2x4 to the underside of the tail.

Cut down to avoid pinching the blade.

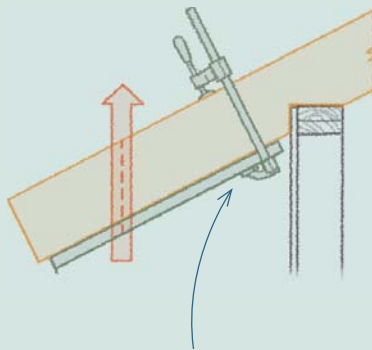
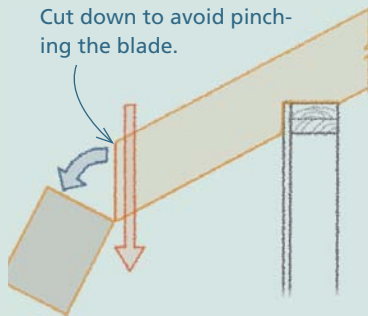

1 If you must cut up, clamp a length of scrap to the bottom of the rafter or truss tail.

2 If the scrap piece is wider than the 2x rafter tail, a tongue of material will be left when the tail is trimmed, which will prevent the offcut from falling.

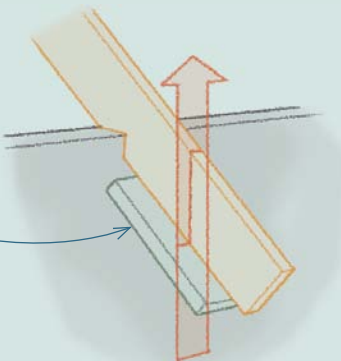

TOP TIP

Don't Sweat the Small Stuff

On narrow eaves, the soffit material can be nailed directly to the horizontal cut on the eave. On wide eaves, where soffits will be nailed to additional blocking, some carpenters like to cut slightly above the subfascia line on the rafter tails. If the rafter tail won't be part of the soffit framing, there's no reason to fuss over the cut.

STEP 4 Mark level lines

On truss tails, this step is not normally necessary because the bottom of the subfascia is set even with (or below) the bottom of the plumb cut. For a stick-built roof, measure the distance from the top of the plumb cut to the level line marked on the first rafter/truss.

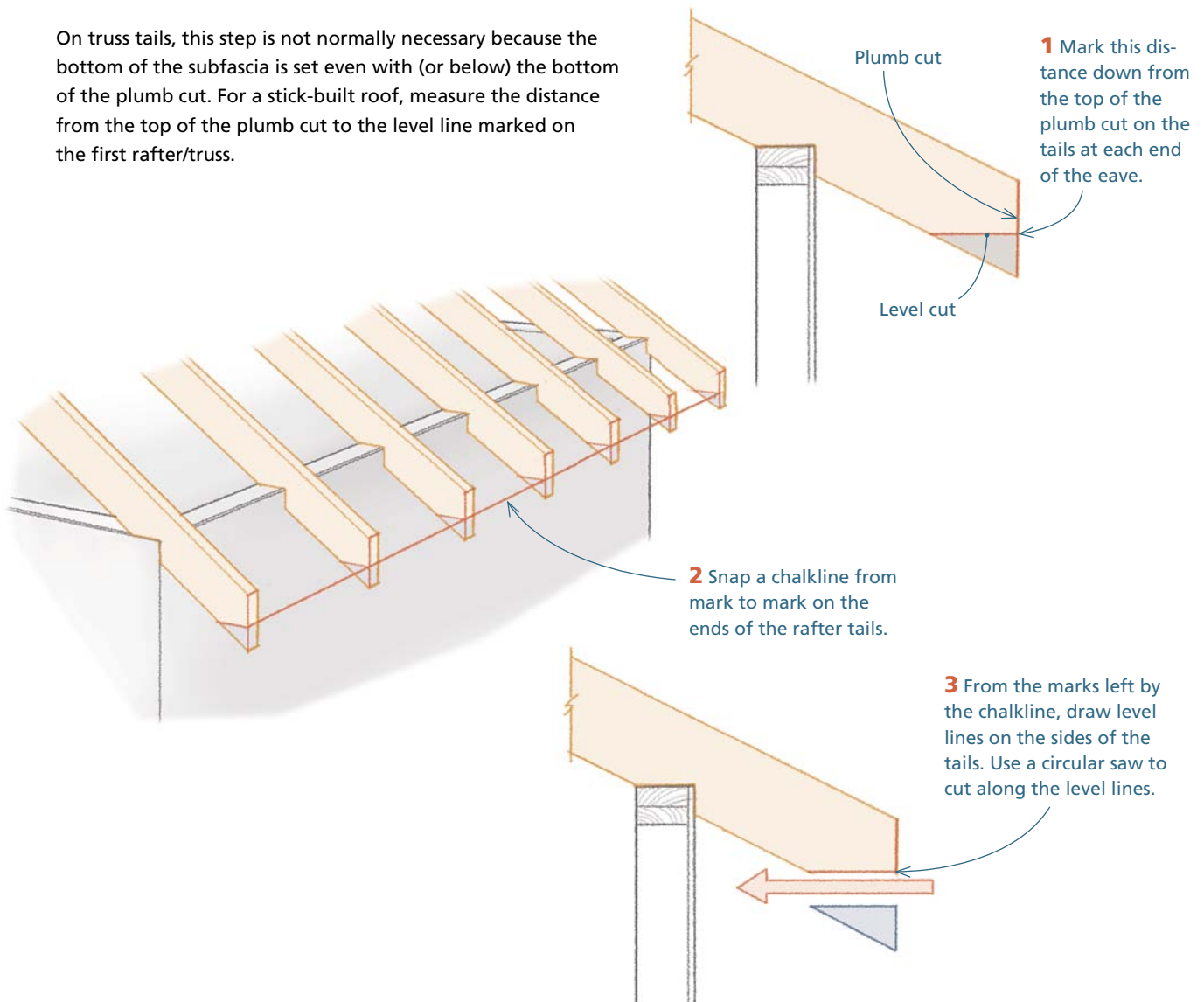

Subfascias

Carpenters disagree over the need for a subfascia. If you decide to use one, you have two options: Choose a material size that fits, uncut, under the sheathing, or rip the top of the subfascia to fit snugly under the sheathing.

Leaving the top of the subfascia square The subfascia can be left square on top and set so that the outside edge is just touching or slightly below the underside of the roof sheathing. This method is often used when installing a 2x4 subfascia on 2x4 truss tails. Use a straightedge, as shown in the top drawing on the facing page, to keep the outside corner of the subfascia in plane with the top of the truss.

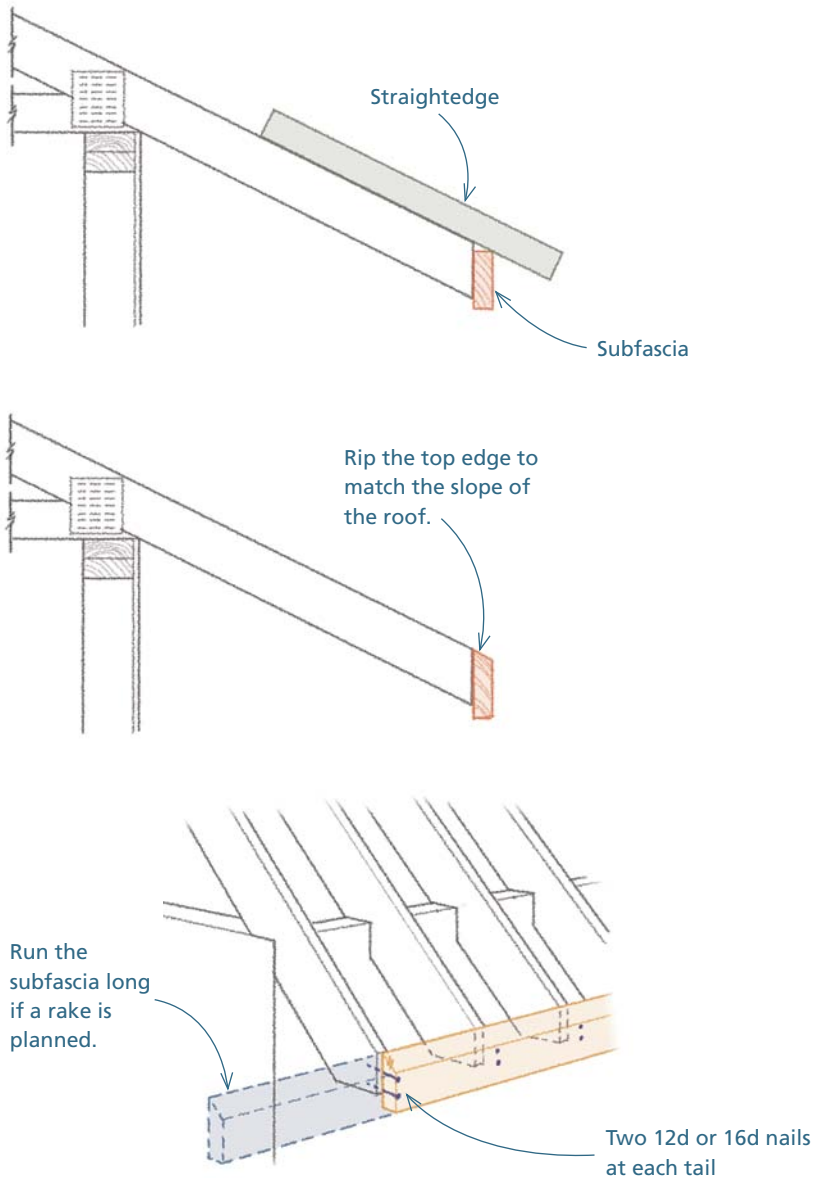

Ripping the top of the subfascia To provide a full nailing surface for the roof sheathing, rip the top of the subfascia at an angle equal to the roof pitch. Measure the size of the plumb cuts on the ends of the rafter tails, and mark that width along the length of the subfascia material. If you want the bottom of the subfascia to end up a bit below the level cut on the rafter tail, mark the width $\frac{1}{4}$ in. wider than the plumb cut. Set your saw to the degree equivalent of the roof pitch and cut along the line.

Installing the subfascia Drive two 12d or 16d nails at each tail to install the subfascia. As you nail it off, have a helper at the far end lever the board up or down until it's in plane with the top of the rafter or truss.

Advantages of Using a Subfascia

Not all carpenters use a subfascia. You can save time and material by simply nailing the finish fascia to the rafter/truss tails. To help support the outside of the soffit material, some carpenters rout a groove in the back of the finish fascia. They slip one edge of the soffit material into this groove, then nail the other edge to a ledger attached to the wall.

Other carpenters rely on cross blocks that are nailed to the sides of the tails. Although the subfascia can be eliminated, it enhances the quality of the finished job in several ways. First, it provides a continuous nailing surface for the soffit and, sometimes, for the edge of the roof deck. This translates into a straight and secure edge for both surfaces.

Second, a subfascia serves an important structural role when an overhanging rake is planned. The subfascia can be extended out past the corner of the house, where it helps support the overhang rakes and rake/cornice returns.

Finally, the subfascia provides a solid surface the whole length of the eave for receiving gutter spikes or screws.

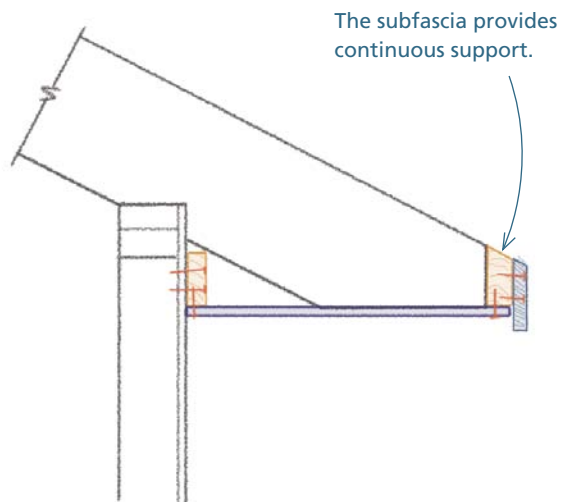
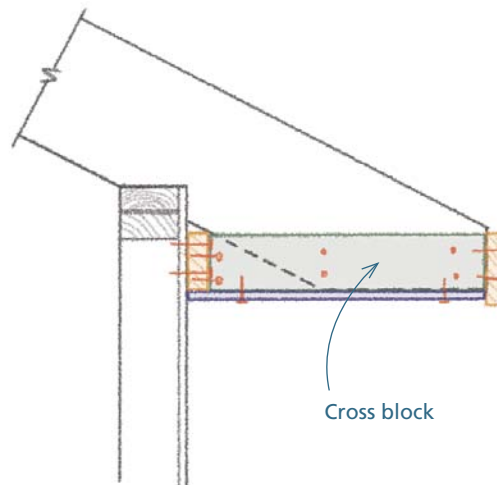
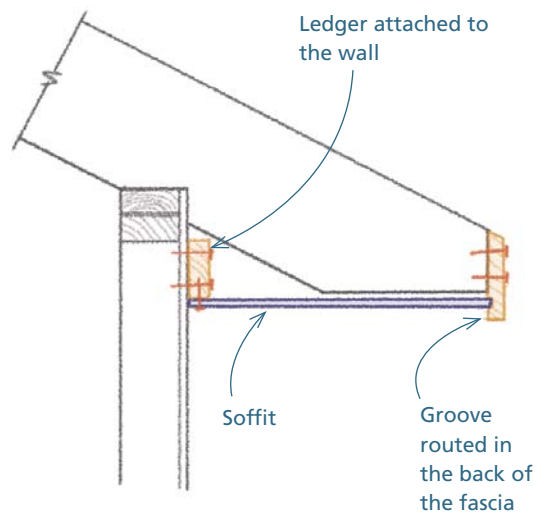

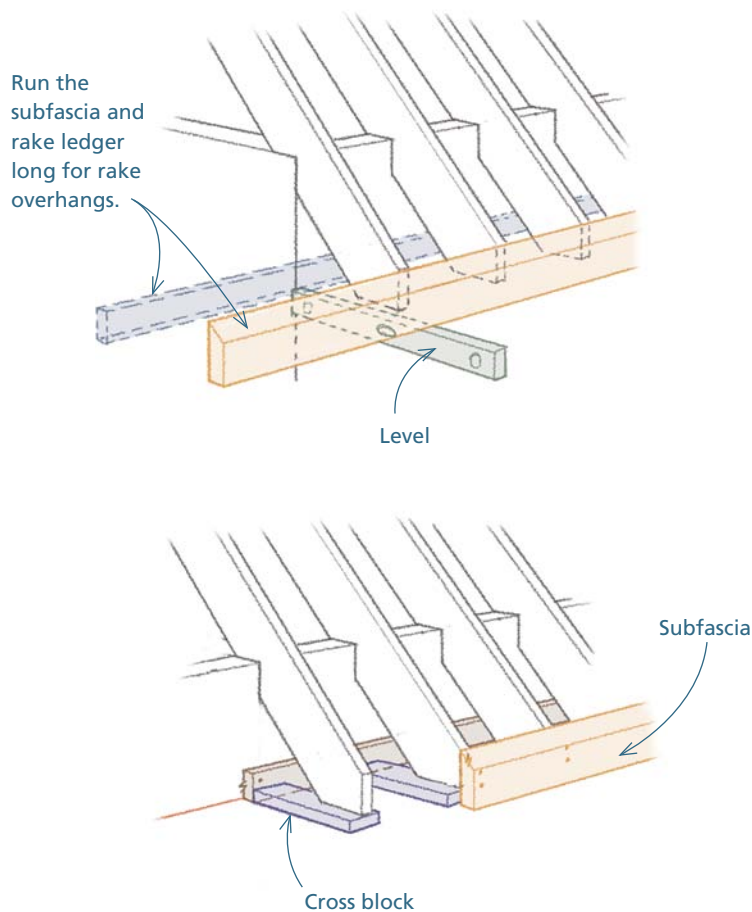

If you plan to use rake overhangs, let the subfascia run past the ends of the house. Make sure that this piece is attached to several tails in from the corner and that it extends outside the planned rake.

Installing the ledger Level over from the bottom of the subfascia, and mark both ends of the wall. Strike a chalkline between the marks, then nail the ledger along the line. If you plan on building a rake or cornice return, let the ledger run past the corner. Make sure it extends beyond the planned rake.

Adding cross blocks Narrow eaves without continuous eave vents do not require cross blocks (also called “soffit joists”). If you plan on using continuous eave vents or have eaves that are more than 12 in. wide, you need cross blocks.

If you’ve used a subfascia, you can install the cross blocks flat to provide a wide surface for nailing off the soffit. Nail through the subfascia to attach the outside end; toenail into the ledger to attach the inside end. If you have not used a subfascia, install the cross blocks on edge and nail them to the sides of the truss/rafter tails.

Framing Rake Overhangs

There are two basic ways to frame a rake overhang. In the first approach, a ladderlike frame is nailed outside the first rafter or truss. In the second, a series of lookouts are tied to a rafter or truss 16 in. to 24 in. inside the roof. From there, they bear on the gable-end wall and cantilever out to a barge rafter at the edge of the rake.

Building a Ladder-Type Rake

On rakes that are less than 16 in. wide and not subjected to heavy snow and wind loads, a simple ladder-type rake is usually sufficient. These are built outside the gable-end rafter or truss.

● LADDER-TYPE RAKES

This design relies on several things to keep the rake from sagging.

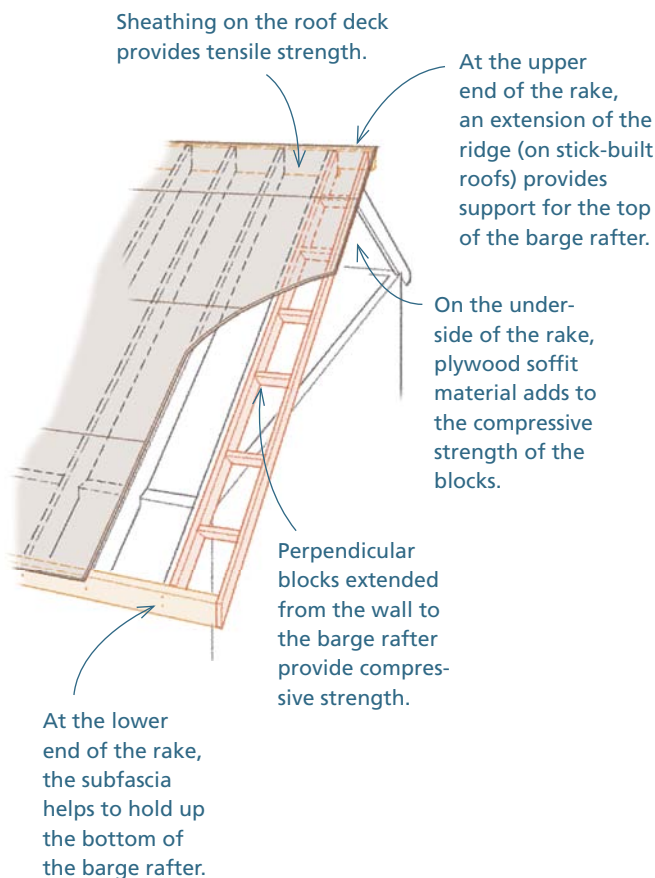

STEP 1 Cut the subfascia and ridge to length

4 Measure and mark a distance that is equal to the distance marked out from the end wall along the subfascia. Cut along the line.

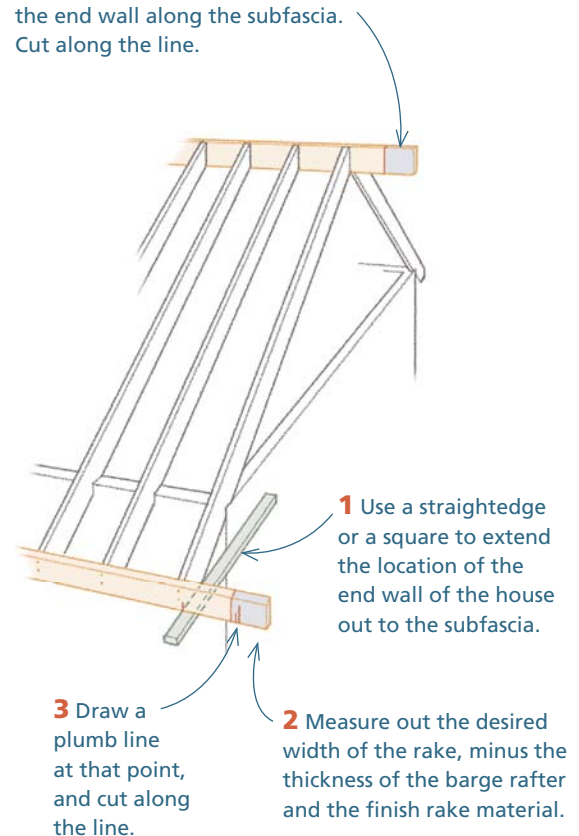

STEP 2 Cut the ridge to width

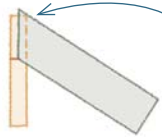

1 Make a plumb cut on a scrap of the barge rafter material (usually a 2x4), and position the scrap against the end of the ridge.

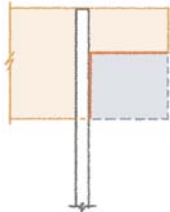

2 Mark the point where the bottom of the scrap piece meets the centerline of the ridge. Cut horizontally here.

STEP 4 Install the barge rafter

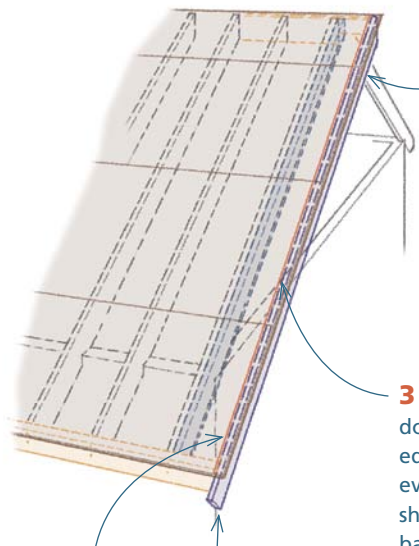

1 Snap a line representing the inside of the barge rafter on the top of the sheathing.

2 Select a straight piece of lumber, and make a plumb cut at the top. Center the barge rafter on the end of the ridge, and nail it in place.

3 Working your way down, hold the inside edge of the barge rafter even with the line (you should be able to see the barge rafter through gaps in the sheathing), and nail through the plywood with 8d nails every 8 in.

4 Let the barge rafter run past the subfascia. Attach the barge rafter to the subfascia with a couple of 12d nails. Cut the barge rafter flush with the subfascia.

STEP 3 Install the sheathing

Install the sheathing on the roof using the methods described on p. 177.

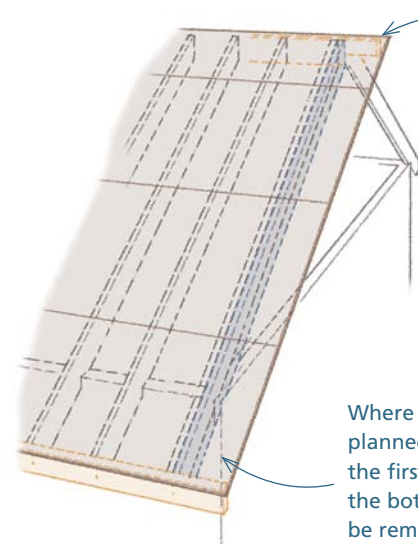

At the end of the roof, leave the sheathing about $\frac{1}{8}$ in. short of the outer extent of the planned rake.

Where a rake or cornice return is planned, you may want to install the first panel of sheathing at the bottom of the rake so it can be removed easily.

STEP 5 Install the ledger and cross blocks

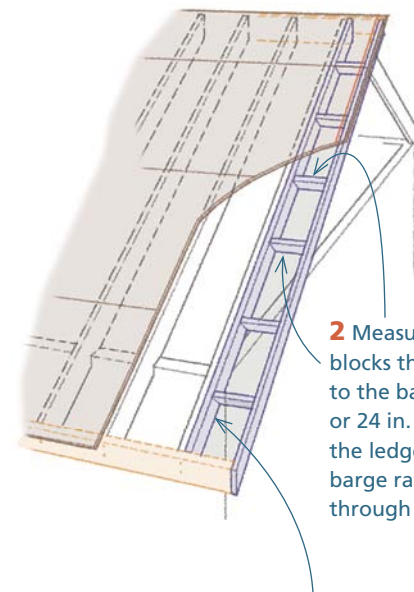

1 Hold the ledger up against the underside of the plywood as you nail it to the truss/rafter.

2 Measure and install cross blocks that run from the ledger to the barge rafter every 16 in. or 24 in. Toenail the blocks into the ledger, and nail through the barge rafter to attach. Also nail through the sheathing.

Building a Cantilevered Rake Overhang

If you're using heavy roofing material, such as slate or tile, live in an area where strong wind or heavy snow is expected, or plan on building a rake 16 in. or wider, you should use a cantilevered rake overhang.

In a cantilevered rake, a series of lookouts are nailed to the first rafter or truss inside the wall. The lookouts bear on the end wall or a notched verge rafter and extend out to a barge rafter at the outside of the rake. This design is more difficult to frame than the ladder type just described, but it's considerably stronger.

There are three ways to support the lookouts at the gable wall.

Method 1: Use a drop-top gable-end truss If you're using trusses, order drop-top gable-end trusses for the rakes (see p. 145). These are lower than the others by the depth of the top chord (typically 3½ in.). After setting and bracing the drop-top gable-end truss, nail the ends of the lookouts to the first truss inside the end wall and have the lookouts extend out to the barge rafter.

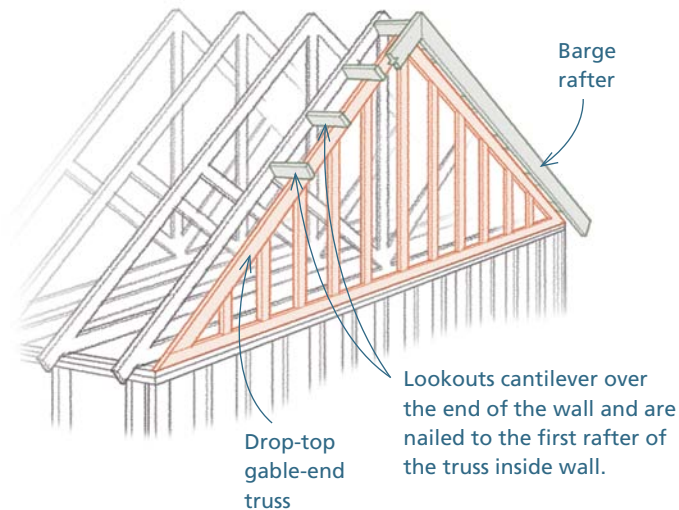

Method 2: Build a dropped gable-end wall Like a drop-top gable-end truss, a dropped gable-end wall is built a set distance (usually 3½ in.) below the top edge of the rafter/truss. See the facing page for a step-by-step example of the layout and construction of one of these walls.

Method 3: Use a notched verge rafter In this system, you lay out a pair of verge rafters for the gable-end wall. The layout for these rafters is just like the layout for the other rafters in the roof. Before installing these rafters, however, you cut a series of notches through which the lookouts can pass. See p. 168 for a step-by-step discussion of how to cut these notches accurately.

Laying Out and Building a Dropped Gable-End Wall

In this example, the building is 24 ft. wide and the roof is a 10-in-12 pitch. The rafters are made from 2x10s. At the top of the dropped gable-end wall, there will be a double top plate. This example follows the process for one-half of the gable-end wall; the other half repeats the process.

STEP 1 Transfer the location of the ridge to the end wall

2 Transfer the location of the end wall to the ridge. Mark the location of the outside of the wall frame, not the outside of the sheathing.

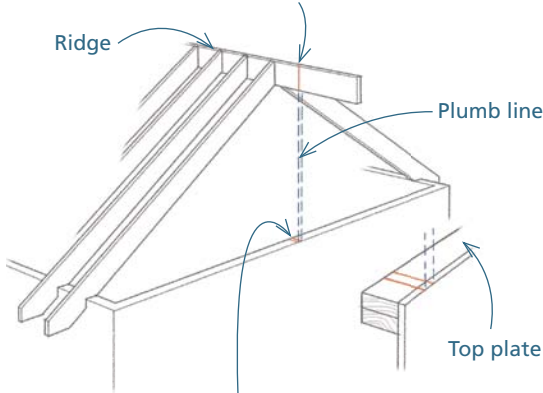

1 Use a level and straightedge, a plumb bob, or a laser level to transfer the location of the ridge to the top of the end wall. Mark both sides of the ridge on the top plate.

STEP 3 Cut and install the lower top plate

Set your saw to a 40° bevel (the equivalent in degrees of a 10-in-12 pitch) and crosscut the plate. From the short point of the cut, measure and mark 184¹/₁₆ in. On the edge of the board, lay out a level cut. Start with a circular saw and finish with a handsaw.

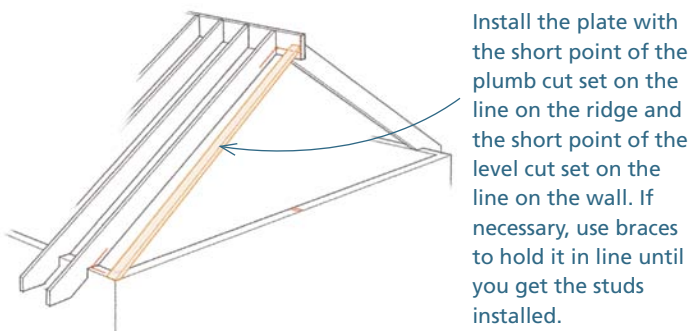

Install the plate with the short point of the plumb cut set on the line on the ridge and the short point of the level cut set on the line on the wall. If necessary, use braces to hold it in line until you get the studs installed.

STEP 2 Lay out the short points of the lower top plate

The bottom of the lower top plate of the gable-end wall should be approximately 6¹/₂ in. below the top of the rafter (lookout width of 3¹/₂ in. plus two top plates). Set a combination square to this dimension.

1 On the first rafter in from the end of the wall, use the combination square to mark the location of the bottom of the lower top plate of the gable-end wall.

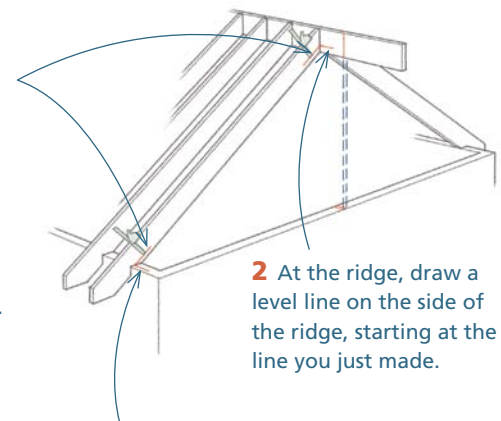

2 At the ridge, draw a level line on the side of the ridge, starting at the line you just made.

3 At the wall that the rafter bears on, draw a line on the top plate starting at the line you just made. You can now determine the length of the lower top plate by measuring the distance between the lines (in this example, 184¹/₁₆ in., short point to short point).

STEP 4 Install the studs and the upper top plate

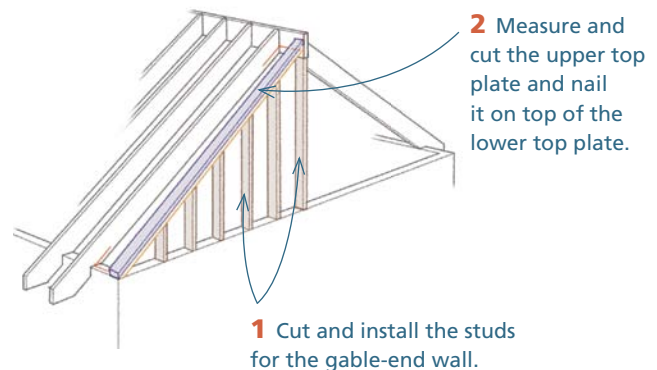

1 Cut and install the studs for the gable-end wall.

2 Measure and cut the upper top plate and nail it on top of the lower top plate.

When You Don't Have a Ridge, Use Math

Another way to lay out the dropped gable-end wall is to use math. Although math is not necessary for this task on a raftered roof, it would be necessary on a trussed roof, where there is no ridge from which to measure. If this were a trussed roof, you'd need to measure the base of the measuring triangle along the end wall. This is the distance between the line you just made on the bearing wall to the center of the end wall. Once you have the

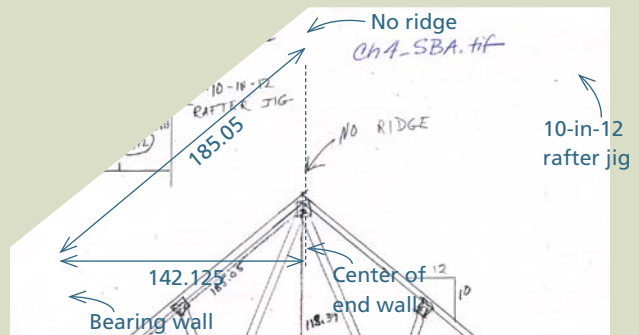

base of the measuring triangle (142.125 in this example), multiply it by the base-1 hypotenuse for a 10-in-12 pitch (1.302) to determine the length of the lower top plate of the gable wall: $142.125 \times 1.302 = 185.05$.

Installing notched verge rafters If you have good woodworking skills and sharp hand tools, you can simplify the construction of cantilevered rakes by using notched verge rafters.

STEP 1 Lay out the notches

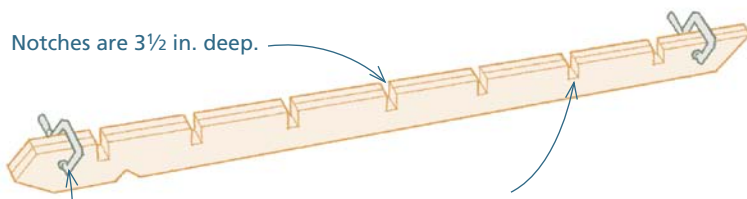

1 Clamp the rafters back-to-back.

2 Lay out the notches on the top edge of the rafters. In this example, the notches will accommodate 2x4 lookouts on edge, installed every 16 in.

STEP 2 Cut the notches

1 Set your circular saw to 0° and cut across both rafters at the same time, staying within the layout marks. Then make five or six quick cuts between them. The ideal depth to make these cuts is $3\frac{3}{16}$ in.; the final $\frac{1}{16}$ in. can then be pared away with a chisel.

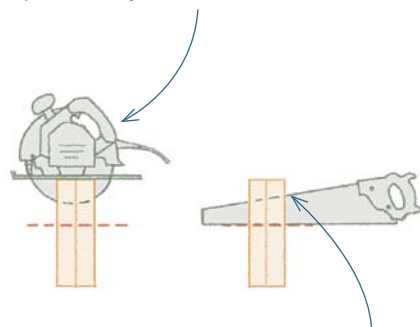

2 Unclamp the rafters, and use a combination square to mark the bottom of the notches at $3\frac{3}{16}$ in. Complete the cuts down to the layout lines with a jigsaw or sharp handsaw.

STEP 3 Clean out the notches

2 Break out the remaining wafers of wood with a hammer.

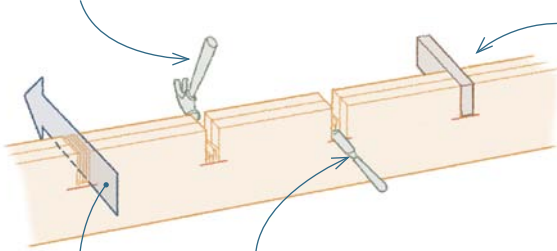

1 Make several passes.

3 Use a sharp chisel to clean out the bottoms of the notches.

4 Test-fit a piece of look-out material. It should be flush with the top of the rafter.

STEP 4 Build the gable-end wall

1 Install the verge rafters in the same manner as the other common rafters.

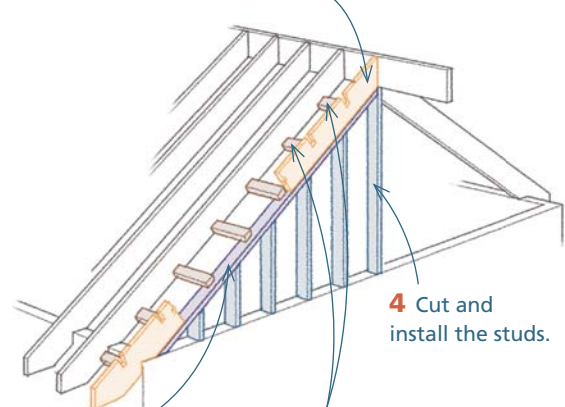

3 Install a top plate flush with the outside of the verge rafter.

2 Install a series of cross blocks between the verge rafter and first rafter inside the house. These blocks should be installed flat and flush with the bottoms of the rafters.

4 Cut and install the studs.

Framing the cantilevered rake The frame for the cantilevered rake is basically the same whether you've used a drop-top gable-end frame, a dropped gable-end wall, or a notched verge rafter.

STEP 1 Trim the ridge and the subfascia

1 Mark and cut the ridge and the subfascia to the correct length. Mark and cut the exterior portion of the ridge to the correct width.

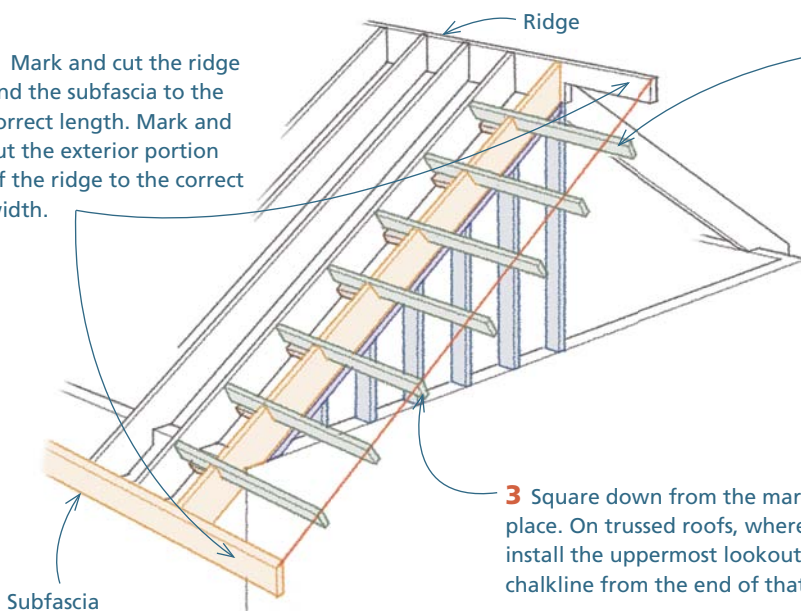

STEP 2 Install the lookouts

2 After bracing the first rafter inside the house, you can simply cut all the lookouts the same length and install them. Alternatively, you can run the lookouts slightly long, stretch a chalkline from the ridge to the subfascia, and snap a line.

3 Square down from the marks, and cut the lookouts in place. On trussed roofs, where there is no ridge, cut and install the uppermost lookout. Then stretch the stringline or chalkline from the end of that lookout to the subfascia.

STEP 3 Install the barge rafter

1 Make a plumb cut on the top end of a long 2x4. Install the top with the plumb cut at the center of the ridge. (If the roof is built with trusses and there is no ridge, center the first barge rafter by using a scrap with a plumb cut on it.)

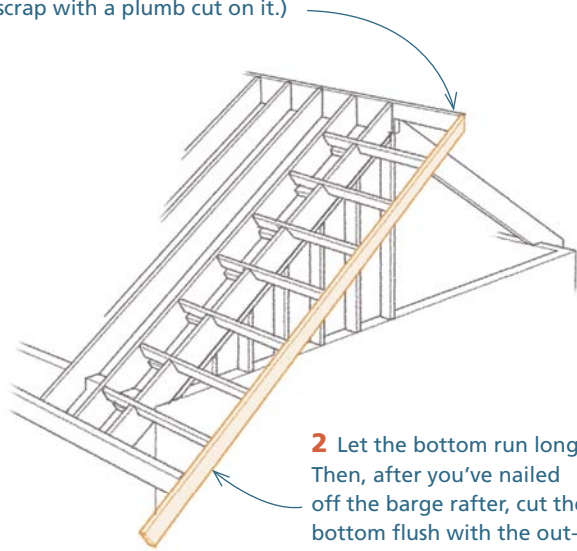

2 Let the bottom run long. Then, after you've nailed off the barge rafter, cut the bottom flush with the outside face of the subfascia.

STEP 4 Install blocks between lookouts

1 On rakes that cantilever over dropped walls, install blocks in the spaces between the lookouts. Blocks keep lookouts from rotating and close off the first rafter bay from the weather.

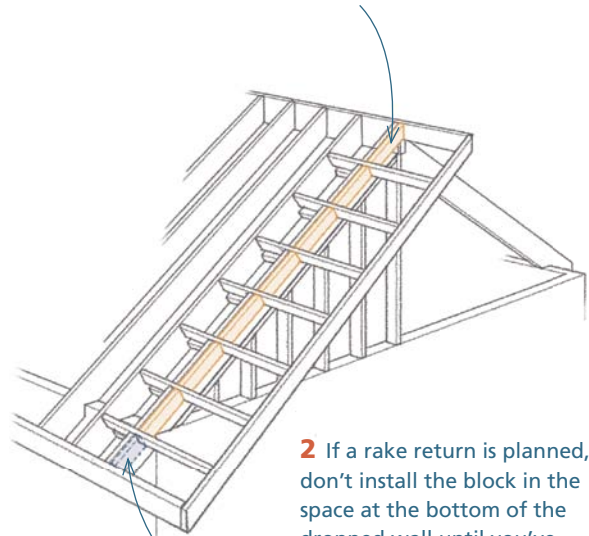

2 If a rake return is planned, don't install the block in the space at the bottom of the dropped wall until you've installed a backing block for the return. Once you have the backing block in place, notch the final block between the lookouts over it. For more, see p. 172 for how to install rake returns.

TOP TIP

Venting the First Bay

.....
If you're planning to use the underside of the rafters as a cathedral ceiling and the design specifies eave/ridge vents, you need to ensure that air flows freely in the top inch or so of every rafter bay. Left unmodified, the lookouts of the rake can block this flow of air. You can provide for this air movement by cutting a dip about $\frac{3}{4}$ in. deep in the top of the lookout in the area that will be inside the bay.
.....

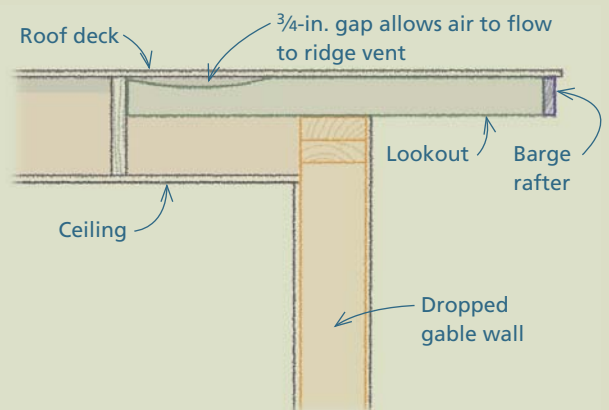

ESSENTIAL SKILLS

Building Structurally Sound Returns

There are several things you can do to ensure that rake and cornice returns are structurally sound.

Anchor the ledger and subfascia deep in the eave

Rake and cornice returns get most of their structural support from the ledger and subfascia of the eave. When you install these pieces, therefore, make sure they're anchored several feet into the length of the eave. Make sure the ledger and the subfascia extend to the end of the rake. The surest way to do this is to install them long and cut them in place.

Think ahead

If you don't think about the return until after you've installed the roof sheathing, it can be difficult to securely



Leave this sheathing off until the rake return blocking is installed.

anchor key parts of the return up inside the rake. To avoid having to compromise these connections, do the following:

If possible, don't install the sheathing on the lower outside corners of the roof. You can sheathe the rest of the roof and leave these corner pieces for later. Or, if you prefer, you can cut and tack them in place so they can be removed easily. After you finish the return, you'll be able to reinstall these pieces quickly.

If you don't want to delay the installation of the sheathing, at least place backing blocks in the rakes. Having these in place makes your job a lot easier when you get around to framing the return.

When a cornice return is planned, build the return before you install the barge rafter and the sheathing.

Rake and Cornice Returns

Rake and cornice returns provide a graceful transition from the level eave to the sloping rake. Cutting and fitting the angled pieces for this transition is difficult, but the biggest challenge of this job is structural. The returns have almost nothing under them because they're located outside the corner of the house.

As with eaves and rakes, the designs of returns vary considerably. This section uses three examples to show how to build common rake and cornice returns. The approaches presented here can be applied to many different designs.

Basic rake return

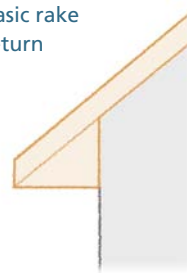

Cornice return with shed roof



Cornice return with hip roof



Framing a Basic Rake Return

Using the subfascia and ledger for support, build the rake return in two layers.

STEP 1 Cut the ledger

Use a level to transfer a plumb line down from the inside of the barge rafter to the ledger. Cut the ledger in place.

STEP 2 Install a backing block above the ledger

At the inside of the rake, there are two possible scenarios. If you have a ladder-type rake or you've used a notched verge rafter, the first rafter will be flush with the gable-end wall. If you've used a drop-top gable-end truss or built a dropped gable-end wall, there will be a space above the truss or wall.

● LADDER RAKES OR VERGE RAFTERS

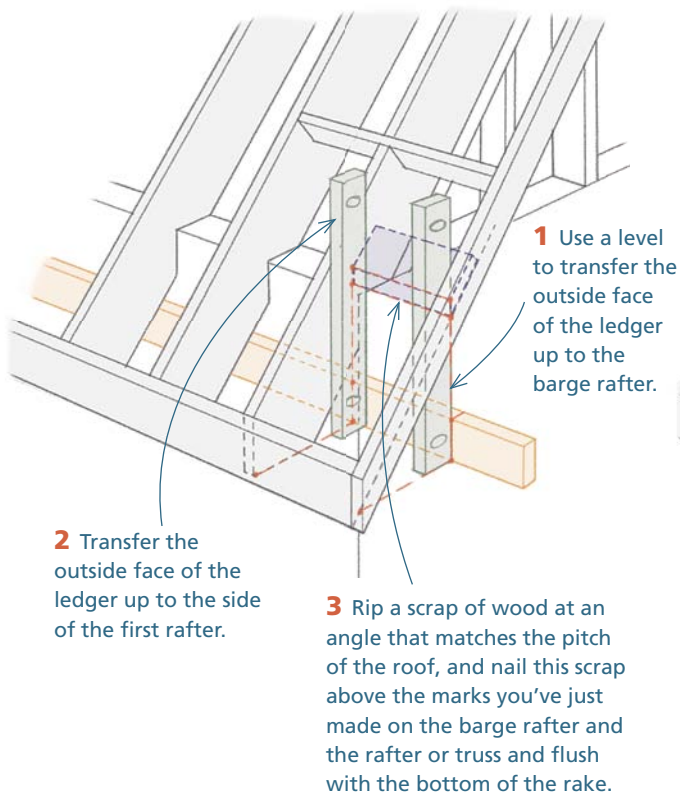

● DROP-TOP TRUSS OR DROPPED GABLE-END WALL

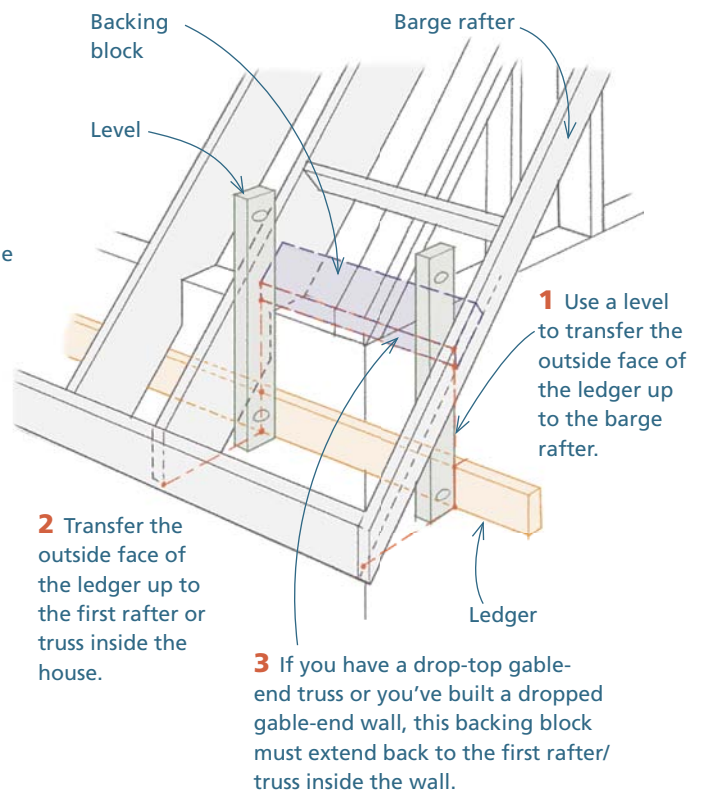

STEP 3 Install the first layer

Frame the basic shape of the return with 2×4 and 2×6 scraps.

- 1 Nail a vertical 2x4 on each side of the back of the return.

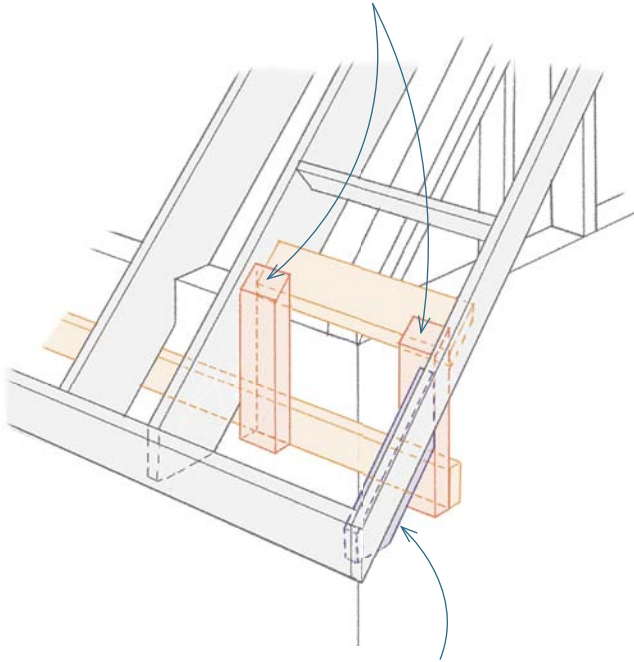

- 2 Cut a piece of 2x6 that fits inside the barge rafter. Hold the piece so that the top is flush with the top of the barge rafter and nail it in place. There should be about 2 in. of the 2x6 sticking out below the barge rafter.

STEP 4 Install the second layer

Cut and fit pieces to bring the recessed surfaces of the return flush with the ledger and rake.

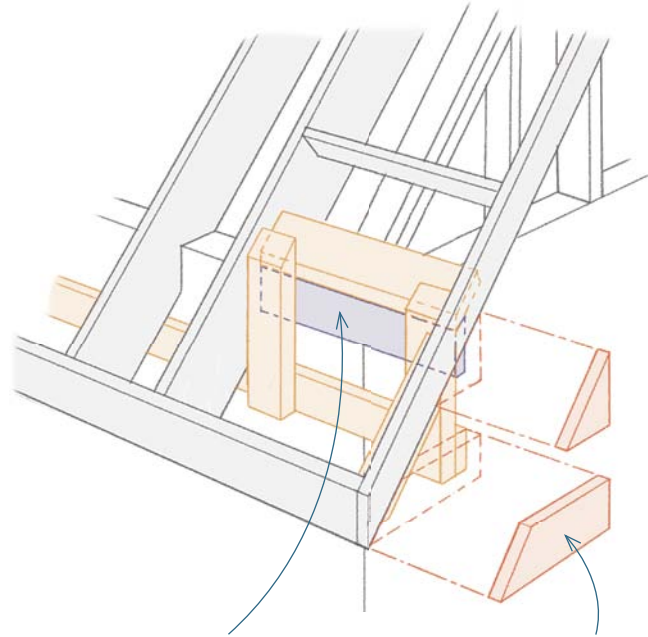

- 1 Rip a scrap of wood at an angle that matches the pitch of the roof. Cut and install this piece on the vertical pieces. The outside end should be even with the inside of the barge rafter. The top should be against the backing block in the rake. The face of this block should be flush with the face of the ledger.

- 2 Cut a triangular piece to pad out the side of the return. (On large eaves and on steep-pitched roofs, you'll need two horizontal pieces.)

Framing a Cornice Return

A cornice return (also called a Greek return) brings the eave and fascia of the main roof around to the gable-end side. Above them, a diminutive roof is tucked up under the rake. The roof, which is sometimes called a water table, can be a shed roof or a hip roof. The size and configuration of cornice returns vary. A return that is 24 in. to 30 in. long, however, is fairly common.

The following examples provide step-by-step procedures for building two types of cornice returns. In both examples, the process begins before the barge rafter has been installed.

Building a Cornice Return with a Shed Roof

This section describes a method for building the simplest type of cornice return, one that features a basic shed roof.

STEP 1 Cut the subfascia and the ledger

As with a rake return, start by installing the ledger and subfascia long and then cut them in place when you build the cornice return.

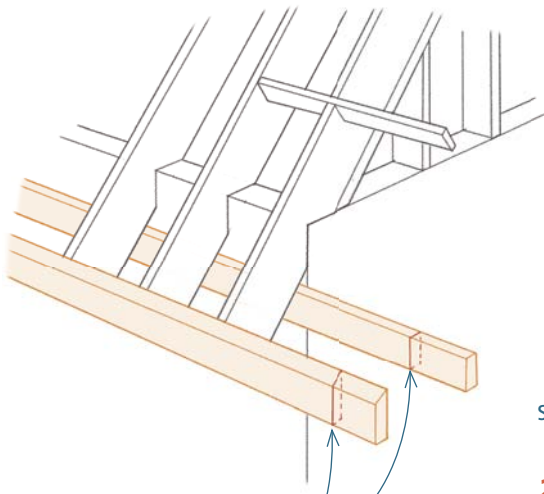

On both the subfascia and the ledger, measure and mark the desired width of the rake frame, minus the thickness of the barge rafter. Scribe plumb lines at these points and cut along the lines.

STEP 2 Install the ledger on the gable-end wall

Draw the cross section of the cornice return full size to determine the width of the ledger. Rip the top of the ledger to the pitch of the cornice return roof. In most cases, a single ledger made from a wide piece of lumber is wide enough to extend from the bottom to the top of the ledger. You can use two pieces, one for the top and one for the bottom, if necessary.

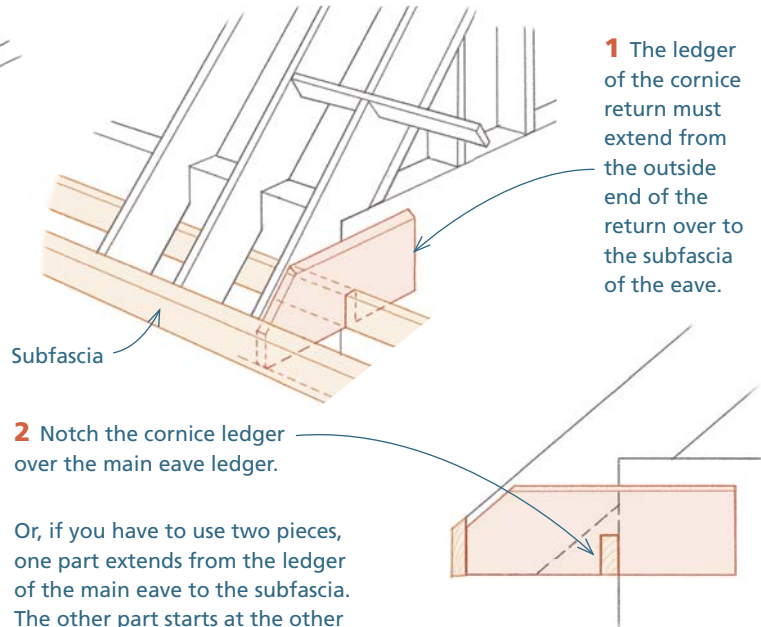

1 The ledger of the cornice return must extend from the outside end of the return over to the subfascia of the eave.

2 Notch the cornice ledger over the main eave ledger.

Or, if you have to use two pieces, one part extends from the ledger of the main eave to the subfascia. The other part starts at the other side of the ledger of the main eave and extends to the end of the cornice.

STEP 3 Extend the subfascia around to the gable-end wall

Cut the subfascia to length and width and nail it to the ends of the subfascia and ledger of the main eave.

STEP 4 Install the cornice rafters

Using the techniques discussed on pp. 105–108, lay out, cut, and install the rafters of the cornice return.

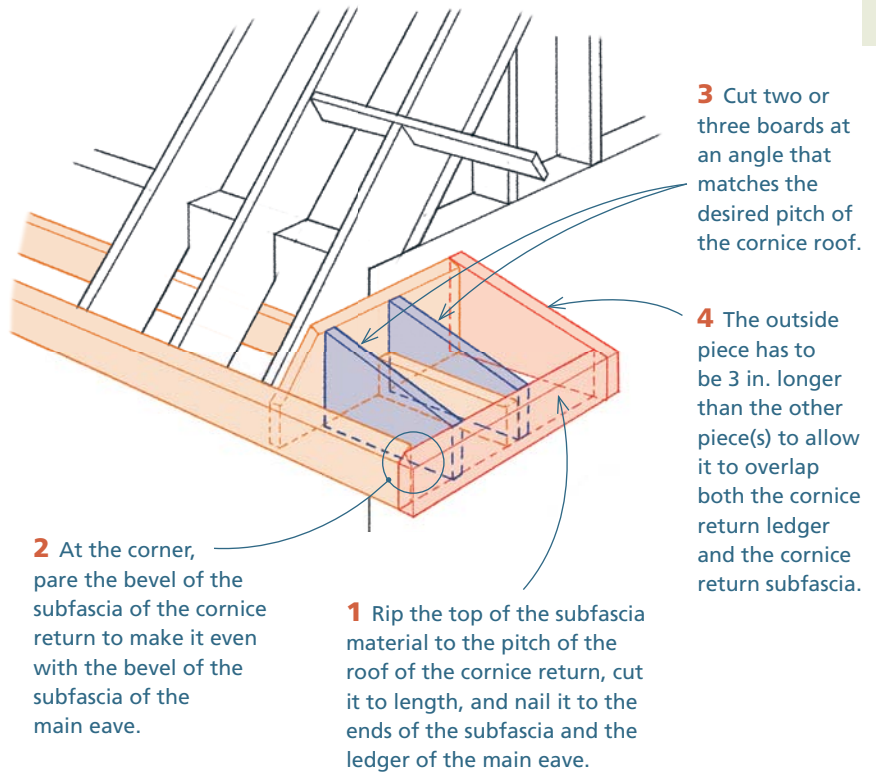

STEP 5 Install the sheathing

Cut the sheathing so that it doesn't extend past the plane of the main roof deck and nail it to the rafters.

STEP 6 Install the barge rafter

Cut the barge rafter to fit over the deck of the cornice return and nail it in place.

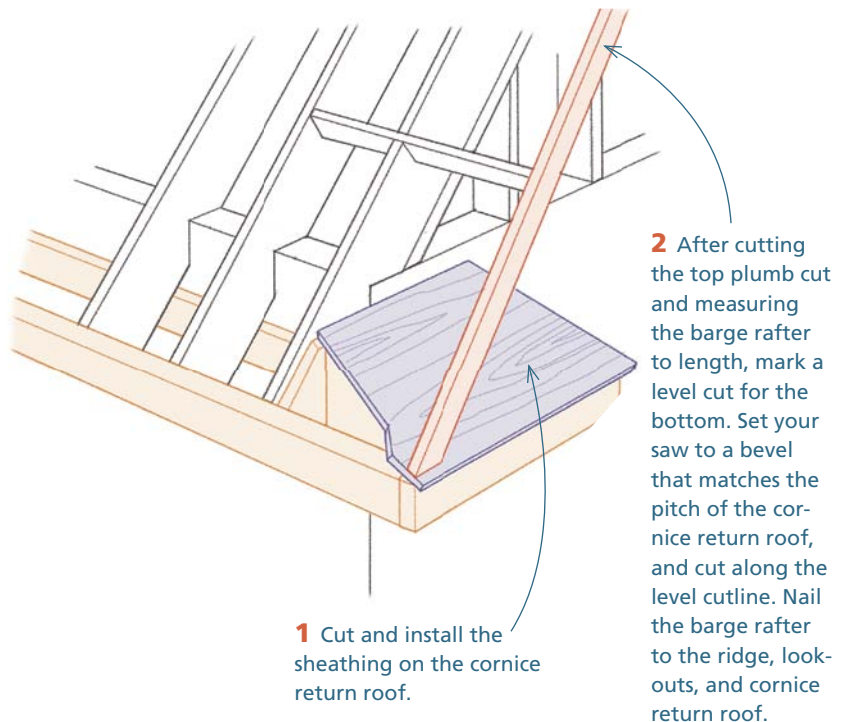

Building a Cornice Return with a Hip Roof

The procedure for building a cornice return with a hip roof is similar to the method for a shed roof. The only difference is the outside end, which has a hip roof. To frame the hip roof, take the following steps:

STEP 1 Shape the end of the ledger into a rafter

Lay out and cut the end of the ledger to conform to the desired pitch.

STEP 2 Extend the subfascia around the corner

Cut and install the subfascia on the front and side of the return.

STEP 3 Install common rafters

Lay out and cut common rafters to the desired pitch.

STEP 4 Cut and install the hip rafter

Using the techniques discussed on pp. 122–127, lay out, cut, and install the hip rafter.

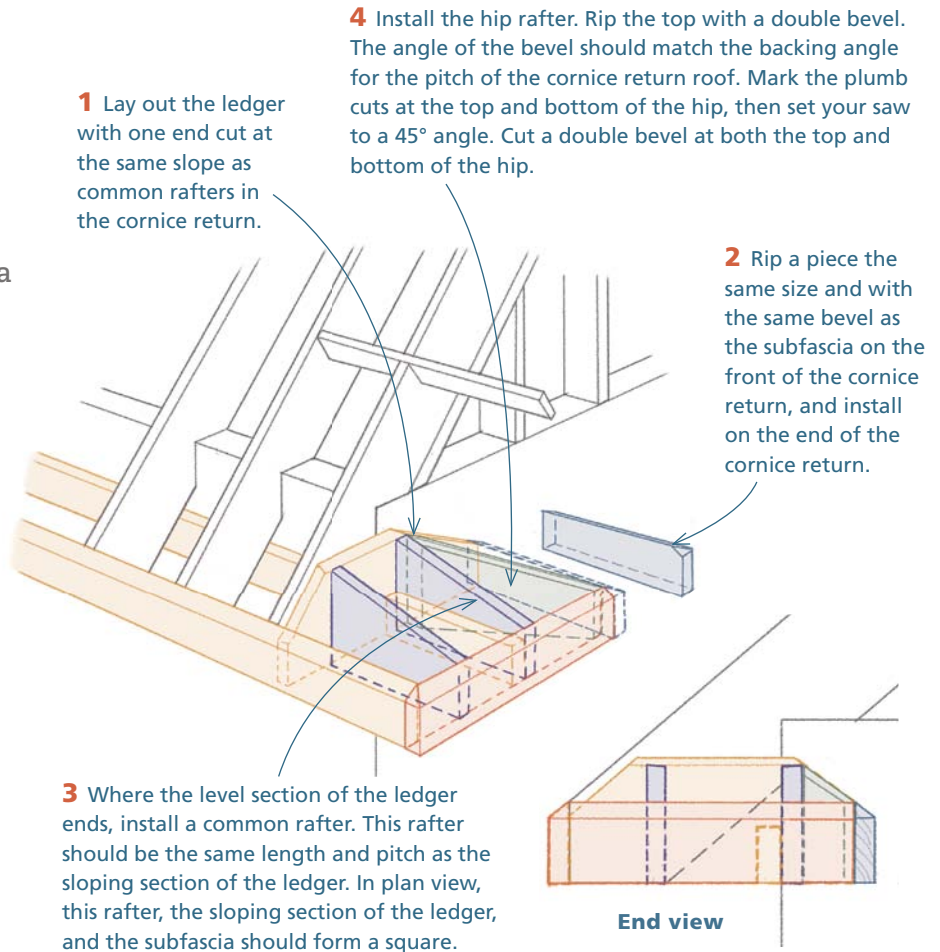

Roof Sheathing

The sheathing on a roof serves two functions. First, it is a substrate for final roofing materials. Second, it plays an essential structural role in the roof frame. In this capacity, it serves as a rigid diaphragm that holds the rafters or the top chord of the trusses in place and keeps the top surface of the roof from moving out of square.

In addition to these structural roles, sheathing can also play an aesthetic one. In some designs, the underside of the sheathing is left open to view. In these cases, the way the sheathing looks when viewed from below is an important part of the design.

Installing Roof Sheathing

When you install roof sheathing, you have to think about more than the sheathing itself; you also need to consider the rafters/trusses below. While the rafters or trusses support the sheathing, the sheathing holds the rafters or trusses permanently in place.

• ROOF SHEATHING BASICS

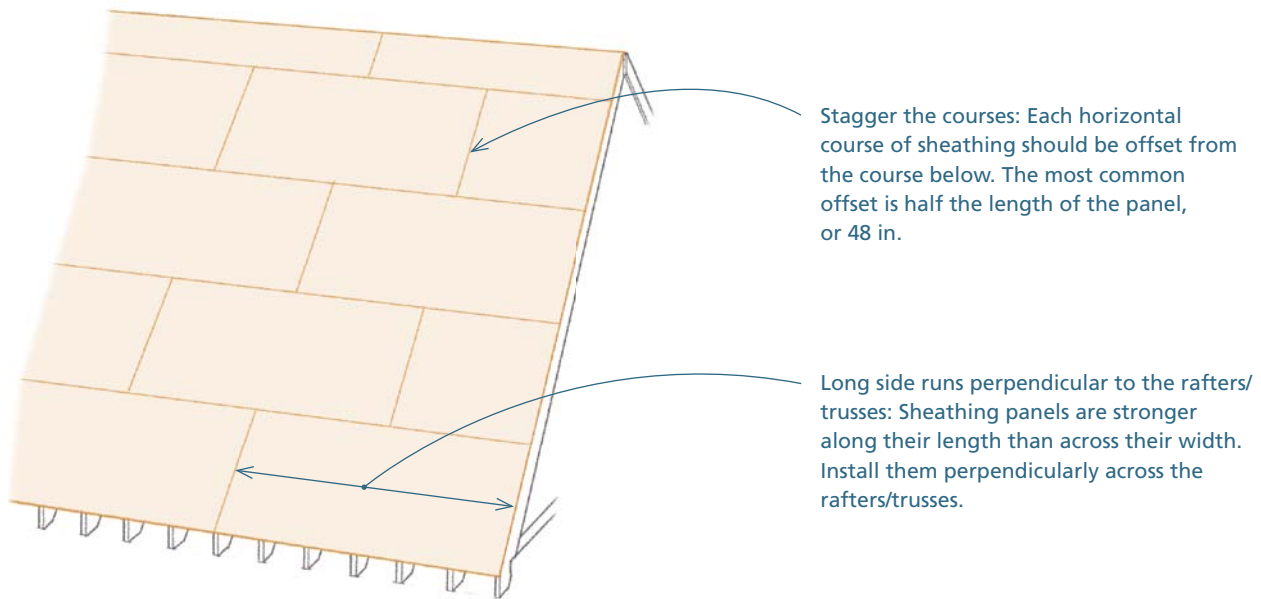

Stagger the courses: Each horizontal course of sheathing should be offset from the course below. The most common offset is half the length of the panel, or 48 in.

Long side runs perpendicular to the rafters/trusses: Sheathing panels are stronger along their length than across their width. Install them perpendicularly across the rafters/trusses.

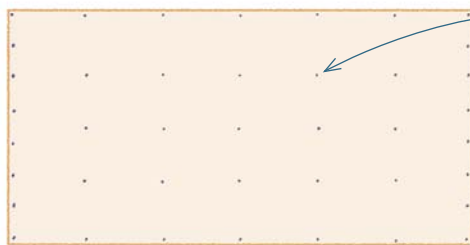

Nailing schedule: In most areas, sheathing should be fastened with 8d common nails. At the ends of the panels, the nails should be placed every 6 in. At the intermediate rafter/trusses, the nails should be placed every 12 in. (This nailing schedule does not meet code requirements in areas prone to high-speed winds. Check local codes.)

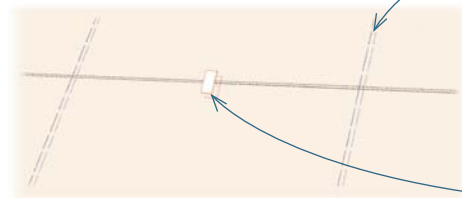

Spacing panels: To provide for expansion of the panels, manufacturers recommend leaving a $\frac{1}{8}$ -in. gap between the edges of the installed panels. Most panels are sized to allow for this space.

Textured side up: When installing OSB, set the textured side up. Doing this provides better footing.

Clips: On trussed roofs, H-clips are required on the edges of panels between trusses. Clips are generally not required on raftered roofs that are laid out on 16-in. intervals.

Sheathing Materials

There are four materials commonly used for roof sheathing: solid-sawn lumber, plywood, OSB, and composite panels.

Solid-sawn lumber

Prior to the 1950s, almost all roofs were sheathed with solid-sawn lumber. Although this material has been largely replaced with structural wood panels (plywood, OSB, and composite panels), solid-wood sheathing performs well and is still in use.

It's used for roof systems where skip sheathing is installed. Skip sheathing, which consists of strips of wood with open spaces between them, has been used for centuries under tile, slate, metal, and wood roofs. Using lumber sheathing also can save money for builders or homeowners if they have a local source of lumber.

But these days, sawn sheathing is primarily used for visual impact. In cabins and in houses where the rafters and sheathing are left exposed to view, solid-sawn tongue-and-groove sheathing is attractive when viewed from below. To optimize the visual impact, the

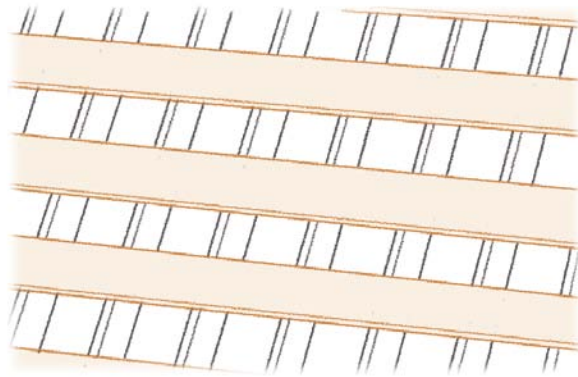

Skip sheathing is still used for certain types of roofing.

edges of the boards are usually milled with a V-groove or a bead.

In some cases, tongue-and-groove sheathing is used along with wood structural panel sheathing. On houses that have open eaves and rakes, where the underside of the sheathing is visible from the ground, the eaves and rakes are often sheathed with tongue-and-groove boards. To save money, however, the rest of the roof is sheathed in wood structural panels.

Plywood

In the 1950s, plywood began to replace solid-sawn sheathing on roofs. Because it was inexpensive, easy to install, and performed well, plywood rapidly gained acceptance and soon became the dominant sheathing material in America.

Plywood is made by gluing three or more veneers or plies into a sheet. Each layer of veneer is set at a right angle to the one below. This configuration gives the plywood strength across both its width and along its length; it also provides dimensional stability.

Plywood manufacturers fabricate the panels with an odd number of plies. The majority of the layers, including the two exterior plies, run along the length of the panel. Because of this, plywood is stronger along its length than along its width.

Plywood is made from three or more plies of veneer.

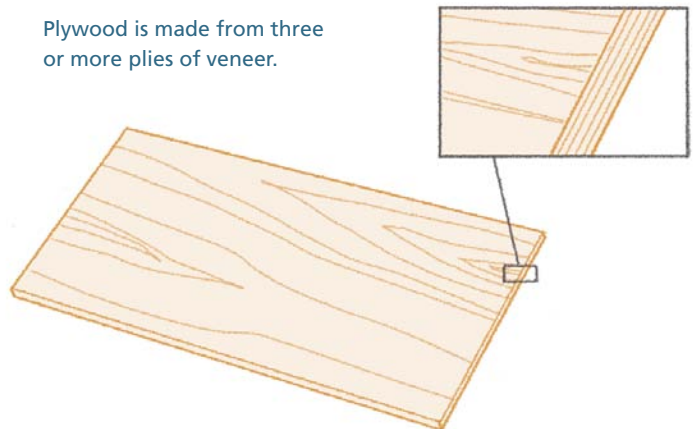

OSB

Waferboard, the precursor of OSB, first appeared in 1963. These panels were produced by randomly placing wood fibers or wafers in the panel. This technology was refined and improved in 1978, when manufacturers developed oriented strand board. In OSB, the strands of wood are oriented, not randomly placed.

OSB panels are made of layered mats. The mats on the external surfaces are composed of strands oriented along the length of the panel. The mats inside the panel are composed of strands that are oriented at a right angle to those on the surface. Because of this configuration, OSB is like plywood in that it's stronger along its length than it is across its width.

Composite panels

Far less common than plywood or OSB, composite panels (such as COM-PLY) offer something of a compromise between the two technologies. The exterior surface of a composite panel is made of conventional veneer; the interior is composed of fibers or strands. In thicker panels, a third layer of veneer, running at a right angle to the surface veneers, is placed in the core of the panel.

Oriented strand board (OSB) is made of layered mats of wood fiber.

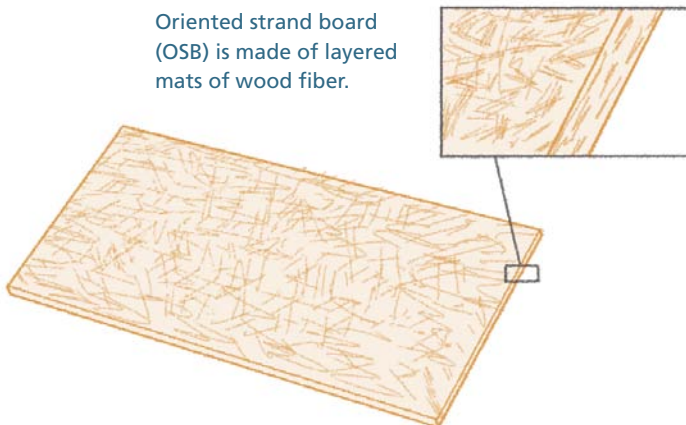

WAYS OF WORKING

Performance Standards for Wood Structural Panels

All model building codes in the United States use the term *wood structural panel* to describe structural sheathing. Model codes do not differentiate between plywood, OSB, and composite panels.

Choosing code-compliant sheathing

Model building codes require that panels used for roof sheathing conform to Department of Commerce Standard PS-1 (for plywood) or PS-2 (for OSB and composite panels).

About 75% of wood structural panels in the United States also are rated by the APA—The Engineered Wood Association. In addition to the PS-1 or PS-2 designations, these panels are stamped with an APA performance rating. Because the APA rating describes the intended use of the panel, it's easy to understand and use.

For most houses, a $1\frac{5}{32}$ -in. panel that's APA-rated for sheathing and is "exposure 1" is suitable for roof sheathing. As far as the code is concerned, it doesn't matter if that panel is plywood, OSB, or a composite panel. In terms of structure, they are considered equal.

● TEMPORARY BRACE

STEP 1 Lay out for the first course

Follow a line to make sure the first course of sheathing stays straight.

STEP 2 Align the panel

After bracing the first rafter straight, set the panel along the chalkline and center it over the last rafter it covers.

STEP 3 Attach the panel

Nail the bottom of the panel to hold it in place then pull or push the last rafter it sits on until it is centered under the end of the panel. When it's centered nail through the panel to hold the rafter in place.

4 Drive a nail in the top corner of the panel to hold that rafter/truss in line with the end of the panel.

Temporary brace

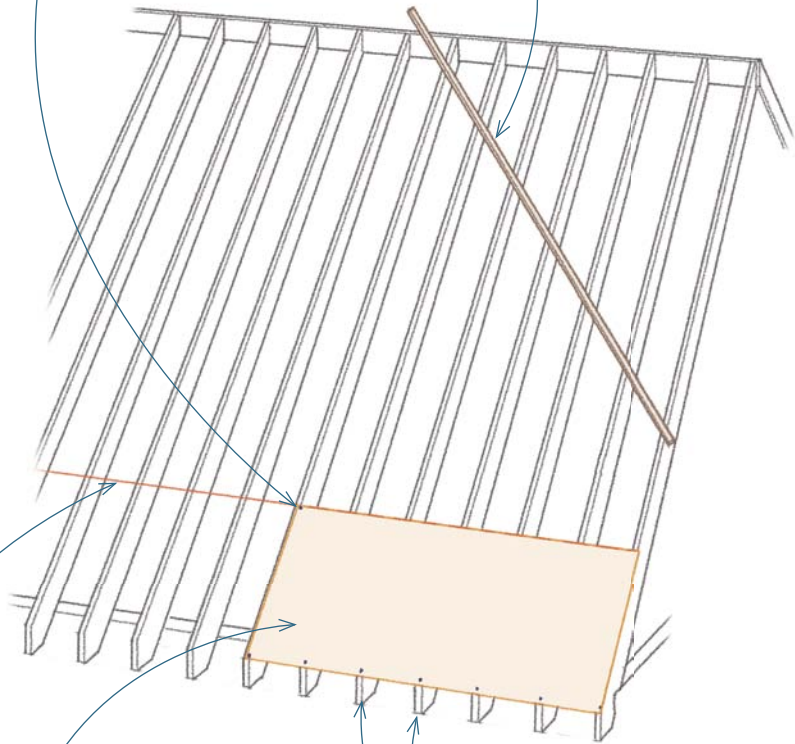

1 Strike a chalkline to guide the first horizontal course of sheathing. Carpenters usually mark this line 48 in. (the width of a panel) above the bottom edge of the roof frame.

2 After making sure that the first rafter/truss is braced in the correct position, set the first panel on the horizontal chalkline. Move the panel along the line until it is just short of the center of the last rafter/truss it can reach, allowing for a 1/8-in. gap between panels.

3 Drive a few nails along the bottom of the panel to hold it in place. If the final rafter or truss tapers along the edge of the panel, push the rafter or truss until it runs parallel with the end of the panel.

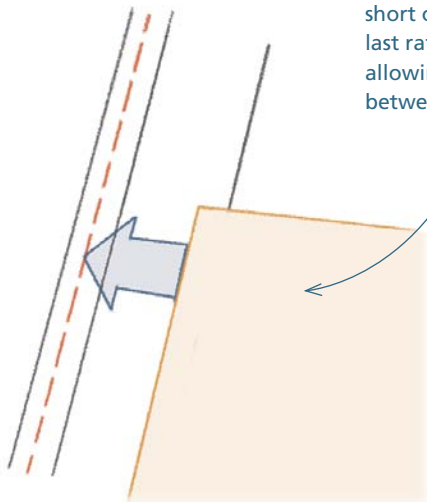

STEP 4 Lay out the top of the panel

Hook your tape measure over the outside edge of the first truss, and pull the layout from that point. Mark the layout on the top edge of the panel, with the layout set ahead. If any of the rafter/trusses need to be adjusted to align with the layout, push or pull them to the layout marks. Anchor them in place by driving in a nail an inch or two from the top edge of the panel. (If you plan on removing the first panel to make it easier to build the rake return, don't drive these nails all the way in.)

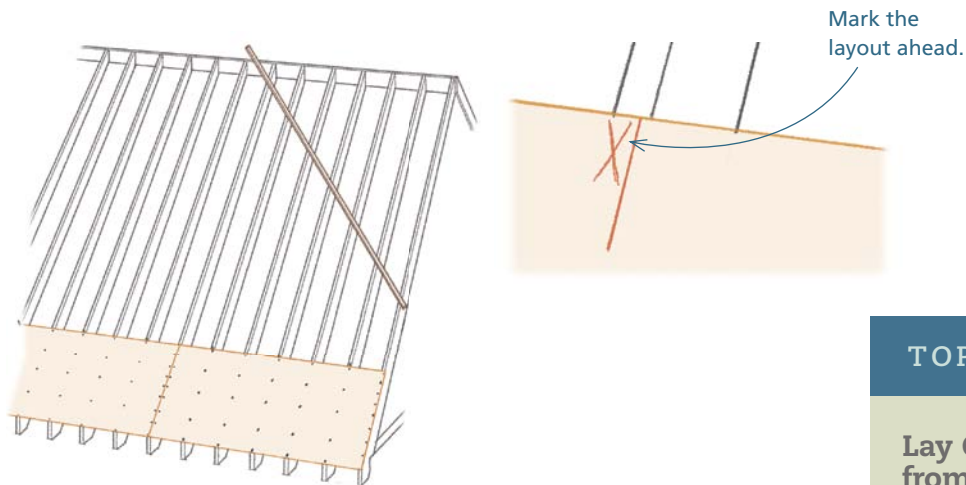

STEP 5 Gap the next course

Before installing the next panel, drive a couple of 8d or 10d nails partway in along the end of the panel just installed. Butting the next panel against the nails creates the required $\frac{1}{8}$ -in. gap.

For each panel in the horizontal course, pull the layout from the same starting point, namely, the outside of the first rafter/truss. As before, mark the layout on the top edge of the panel and push the rafter/truss to the layout marks before anchoring them in place with nails.

You don't need a line for subsequent horizontal courses. Use nails, driven partway in along the top of the panels below, to maintain the required gap. Offset each succeeding course from the one below.

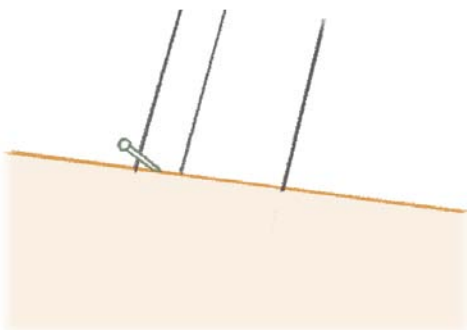

TOP TIP

Lay Out Sheathing from the Top

.....
 If you measure down from the top in 4-ft. increments, you can start the sheathing installation with ripped pieces at the bottom. These ripped pieces will be lighter and easier to handle on the first row of sheathing, which is often the most difficult to install.

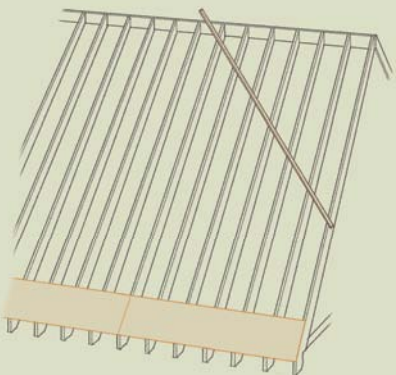

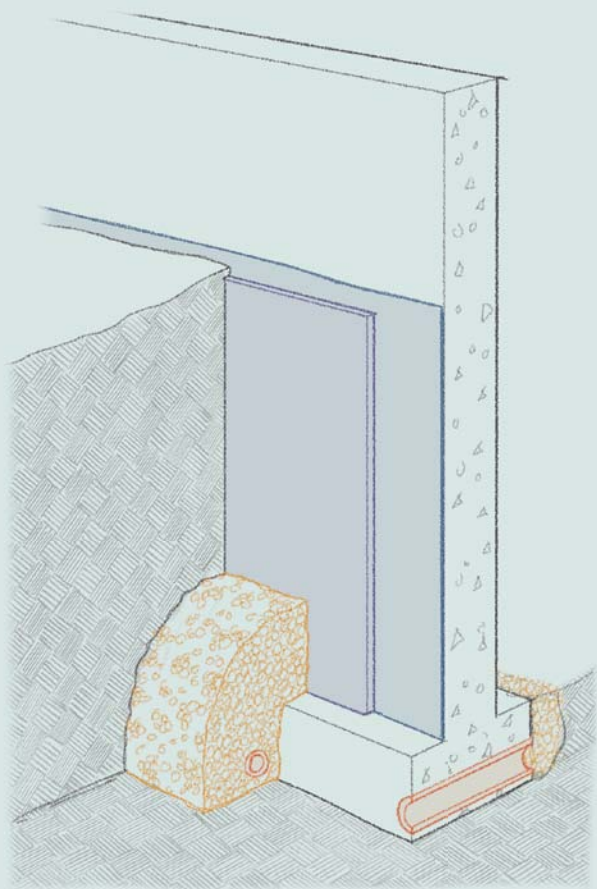
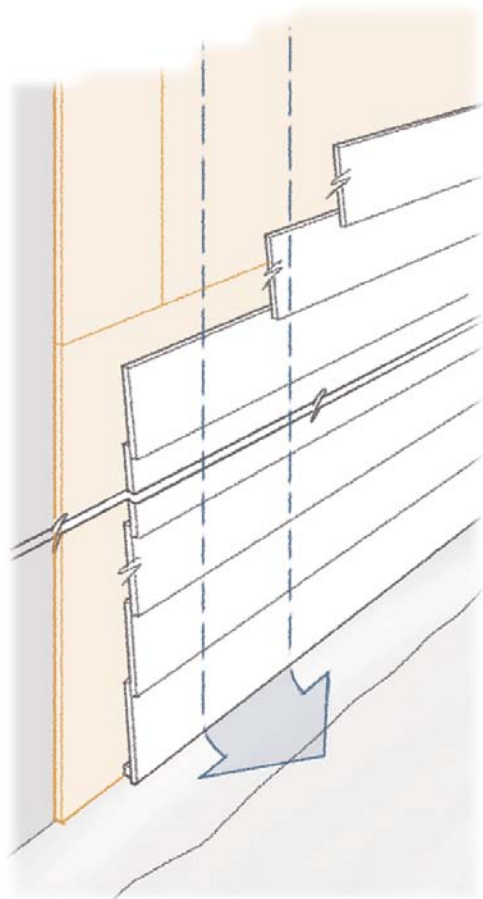
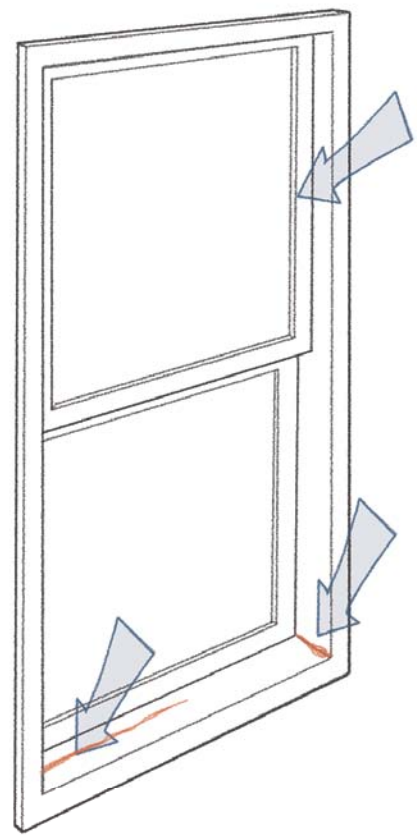
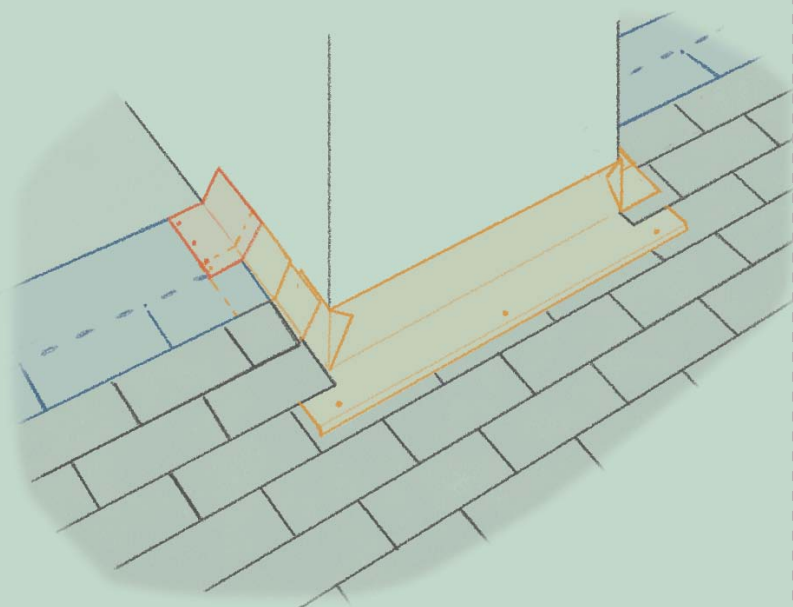

Closing the House to the Weather

CHAPTER 5

.....

184 Roofing the House

CHAPTER 6

.....

231 Installing Windows, Exterior Doors,
Siding, and Trim

CHAPTER 7

.....

278 Controlling Moisture in the Ground
and in the Air

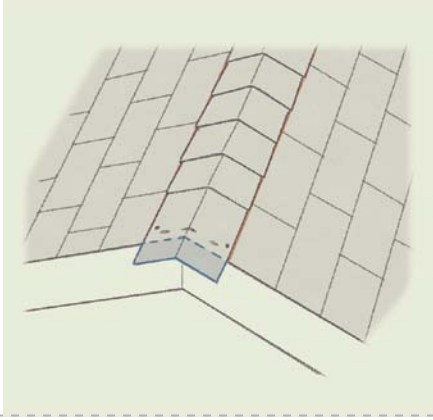
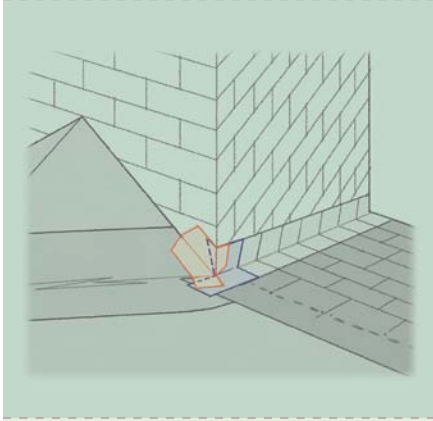
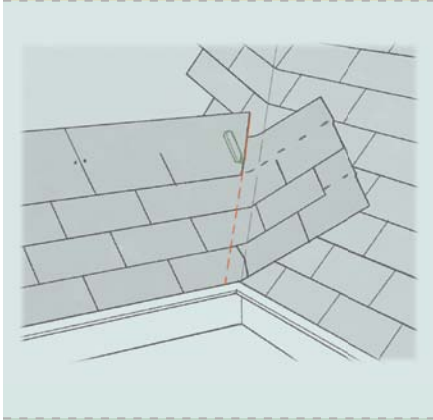
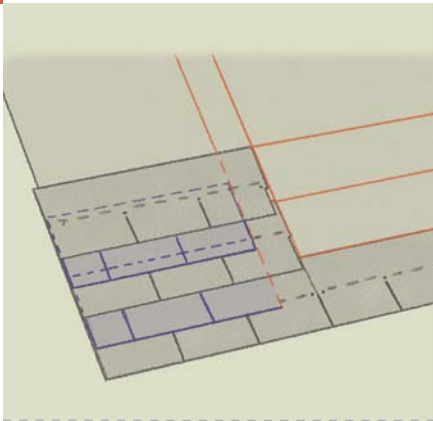

Roofing the House

MODERN HOMEBUILDERS HAVE INHERITED many practices, but few are as ancient or widespread as our basic approach to roofing and siding. When our ancestors were still following herds of wild animals and foraging for edible roots and berries, they often lived in temporary structures framed with tree branches and covered by the skins of the animals they killed. At some point they learned to arrange their hides in an overlapping pattern. This pattern ensured that as rainwater flowed down over one piece of hide, it ran onto the top of the piece below. Once learned, this lesson was surely remembered, for the reward was a dry place to sleep.

Today, this simple principle—that the upper piece always overlaps the lower piece—is still the first and foremost rule for installing roofing and siding. In this chapter (and the next), we'll return again to this basic rule as we examine the techniques that builders have developed to keep rainwater out of houses.

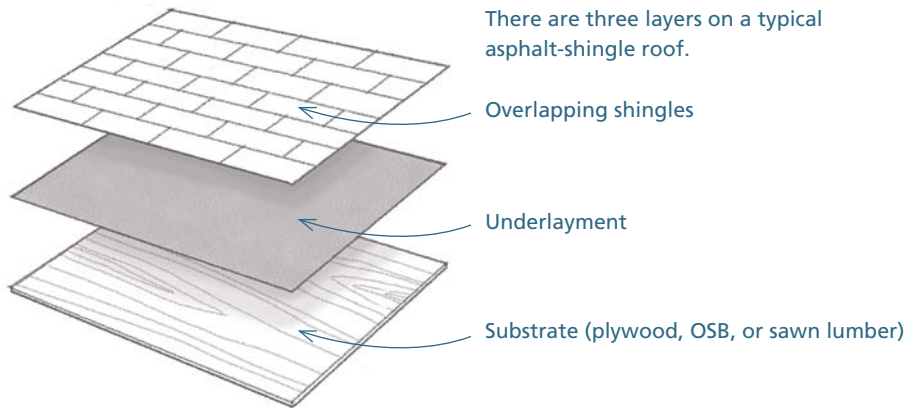

Two Roofing Systems

Roofing is generally divided into two basic systems: low-sloped roofing and steep-sloped roofing. Low-sloped roofing systems are used on roofs with pitches of 3-in-12 or less. Usually, they are used on roofs that are nearly flat. These roofs are used extensively in commercial and institutional construction, and they are rare in residential construction.

Steep-sloped roofs typically require a pitch of 4-in-12 or greater. The most common residential roof in America by far (and the main focus of this chapter) is a steep-sloped roof covered in asphalt shingles.



Low-Sloped Roofs

Because water spreads unpredictably on low-sloped roofs, the roof must form a watertight barrier. Creating this barrier can be challenging and often requires special tools and equipment. These roofs can be divided into four categories.

Built-up roofs Built-up roofs are made from layers of roofing felt (or special fabrics) fused together with bitumen (hot asphalt, hot coal tar, or cold-applied liquid adhesives). They have been in use since the 1840s. Until recently, built-up roofs required an investment in equipment, both to heat asphalt or coal tar and to transport these materials safely up to the roof.

Today, some systems use cold-applied liquid adhesive; others use special adhesives that can be softened with a portable propane torch. Because they require much less capital investment, these cold-applied systems are more practical for small roofing contractors and builders.

Flat-seamed metal roofs Flat-seamed metal roofs have been used for more than a century but they are rare today. Requiring special tools and skills, including the ability to solder, these roofs are expensive and it's often difficult to find roofers able to do them.

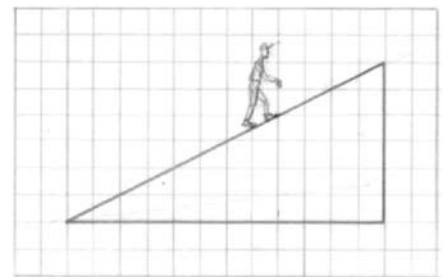

A 6-in-12 roof pitch is about the steepest pitch most people feel comfortable walking on.

Spray polyurethane foam roofs Spray polyurethane foam (SPF) has been used on commercial buildings for more than 35 years. It's produced by a chemical reaction when two liquid components— isocyanate and polyol resin—are mixed at the nozzle of a spray gun. After they're combined, the materials expand to 30 times their liquid volume and in a matter of minutes dry to a solid polyurethane foam. This foam is both waterproof and has a high insulation value. Because of the investment in equipment and training, these roofs are typically installed by specialty roofing contractors.

Single-ply roofs Since the 1960s, a variety of waterproof membranes have been developed for low-sloped roofing applications. The most common of these is ethylene propylene diene monomer rubber (EPDM). Other systems are polyvinyl chloride (PVC) roofing and Curon, a polymer system that cures under ultraviolet (UV) light.

Unlike built-up roofs, these systems have only one ply, or layer. They come in two forms. The first, sheet systems, have special procedures for sealing the seams between the sheets. Some use proprietary sealants; others use heat. The Curon system uses UV light from the sun or an artificial source to weld the sheets together.

In the second form, the membrane comes as a liquid that the installer paints on the roof deck with a brush, roller, or spray equipment.

Single-ply roofs often require special tools and careful installation. However, they typically require much less capital outlay than is required for other low-slope roofing systems. For small residential builders and remodelers who want to do their own low-slope roofs, these systems are the most feasible options.

TOP TIP

Low Slope Advisory

.....
On roofs with pitches between 2-in-12 and 4-in-12, avoid using shingles when there are penetrations (pipes, skylights, etc.) adjoining walls and valleys. When these elements are present, a low-slope roofing system is a better option. Shingle manufacturers do not permit the use of shingles at all on roofs with a pitch less than 2-in-12. The National Roofing Contractors Association is more conservative; it does not recommend the use of asphalt shingles on roofs below a 3-in-12 pitch.
.....

WAYS OF WORKING

Installing a Single-Ply System

.....

If you decide to use this type of roofing system, follow these steps:

1. Study the manufacturer's recommendations carefully. These are usually available in printed form and online. Many manufacturers offer detailed instruction manuals that can be downloaded to your computer.
2. Learn what accessories are available. You'll need these for flashing walls, pipes, chimneys, and roof intersections.
3. Make sure you have sufficient pitch. Although these roofs are often referred to as "flat" roofs, most require a slight pitch (usually a minimum of ¼-in.-in-12).
4. Prep the subsurface carefully, as recommended by the manufacturer. In most cases, the deck must be clean and dry.
5. Keep an eye on the weather. These systems often have to be installed in dry weather and within specified temperature ranges.

Steep-Sloped Roofs

Unlike low-sloped roofs, steep-sloped roofs do not present a watertight barrier to the weather. Instead, they rely on a pattern of overlapping shingles, shakes, or tiles to shed water.

A steep-sloped roof typically consists of thousands of these roofing units attached with thousands of nails. Neither the seams between the units nor the nails are sealed against the penetration of water. The overlapping pattern covers and protects these vulnerable points—so long as water flows in the right direction. If water flows in the opposite direction or spreads laterally, these roofs leak. For this system to work, the roofer has to be able to count on a predictable flow of water.

Using Pitch to Control the Flow of Water

In the abstract, water should flow down the tiniest of grades. But in reality, water lingers on shallow pitches and spreads unpredictably. Water may pool in low spots, or gather behind dams created by debris from trees, dust, and loose granules from the shingles. Another concern is the wind, which can push water laterally or even uphill. As a result of these factors, builders have come to recognize that the minimum pitch for shingled roofs is 4-in-12. From the point of view of controlling the flow of water, steeper is better.

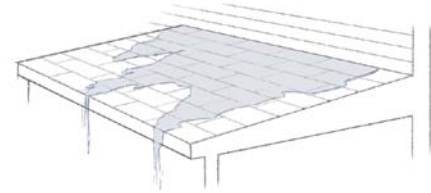
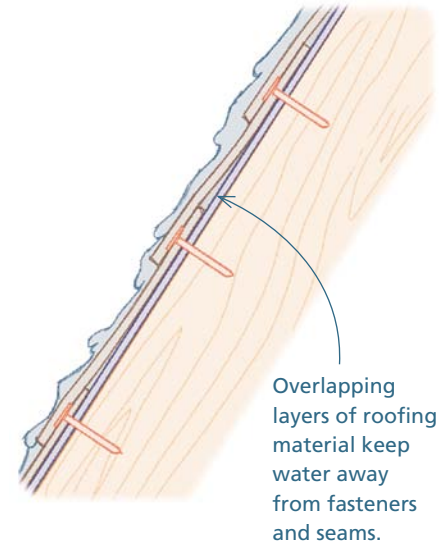

Shingles can be applied to roofs with pitches of 4-in-12 or greater, although lower pitches are accepted by roofing manufacturers as long as special precautions are taken.

WAYS OF WORKING

Shingling Roofs with Less Than a 4-in-12 Pitch

A 4-in-12 pitch is not an absolute minimum for asphalt-shingle roofs. Shingle manufacturers permit the use of asphalt shingles on roofs that have pitches between 2-in-12 and 4-in-12, but they require that special measures be taken before the shingles are installed. You must either install a layer of peel-and-stick elastomeric membrane directly to the roof deck or install a double layer of roofing felt before installing the shingles. These measures amount to a backup roof beneath the shingle roof, and they basi-

cally concede that some water will get through the shingle barrier.

Of the two systems permitted by shingle manufacturers, the elastomeric membrane is superior. The membrane seals around the shanks of the nails used for the shingle installation. When using two layers of roofing felt, on the other hand, the punctures created by the nails used for the shingles are possible sources of leaks. Unfortunately, the use of an elastomeric membrane can triple the cost of a shingle roof.

Measuring Roof Pitch

There are several ways to measure roof pitch accurately:

- **Digital level:** Place the tool so that it runs straight up the roof, and read the pitch in the digital display.
- **Spirit level with integral protractor:** Place the level so that it runs straight up the roof, and rotate the protractor until it reads level. Read the angle and convert it to roof pitch, using the table on p. 504.
- **Pivot square:** Set the pivot square so that it runs straight up the roof. Pivot the tool until it reads level and lock it in place. Read the pitch in the scale on the side of the tool.

If you don't want to invest in these or other special tools, use the following procedure:

1. Place a wide board so that it runs straight up the roof.
2. Use a level to mark a level line on the side of the board.
3. Take the board down to a worktable.
Starting at the point where the line intersects the bottom of the board, measure and mark 12 in.
4. Use a square to mark a perpendicular line down from the mark to the bottom of the board.

5. Measure the length of the perpendicular line to ascertain the x-in-12 pitch.

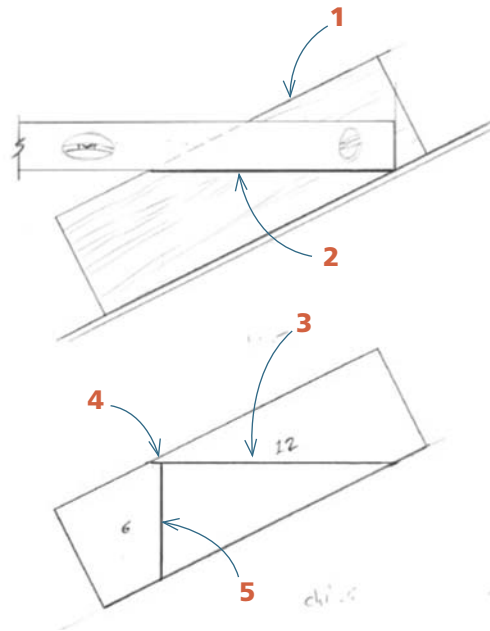

Protecting the Fasteners and Seams on Steep-Sloped Roofs

Relying on a predictable flow of water, roofers use a logical system of overlapping units to keep water away from fasteners and seams.

In most steep-sloped roofing systems, rainwater reaches very few fasteners. Each horizontal course laps over the fasteners of the course below, which keeps the fastener dry. The few fasteners left uncovered at the top of a roof are typically protected by sealant.

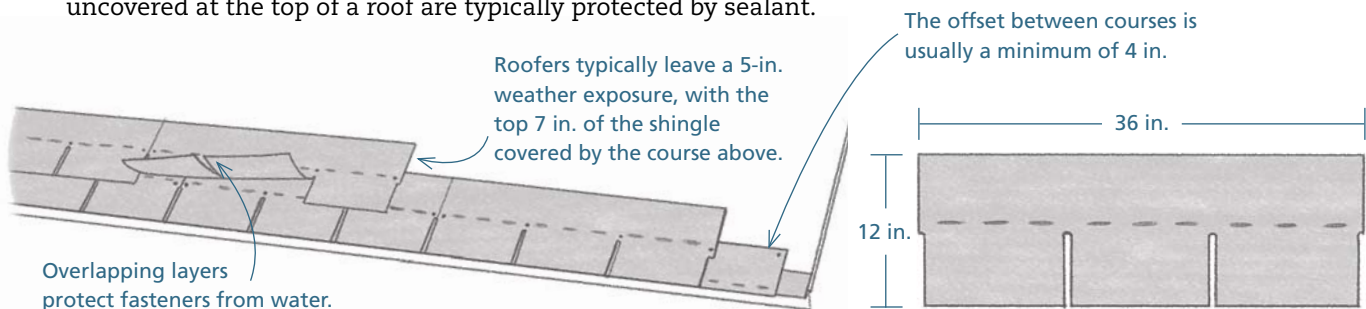

● STANDING-SEAM METAL ROOFS

Interlocking seams between sheets of metal are raised and covered to keep water out.

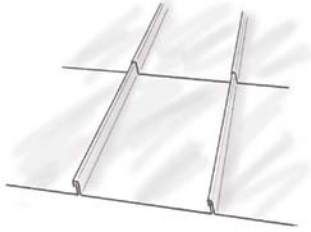

● TILE ROOFS

The edges of roofing tiles are raised above the flow of water, preventing leaks. An overlap of 2 in. between vertical courses is usually enough.

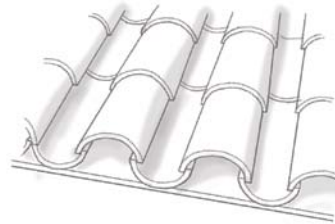

Asphalt-Shingle Roofs

Since their development in the early 1900s, asphalt shingles have come in many sizes and shapes. Today, however, most asphalt shingles are either flat (usually three-tab) shingles or laminated (often called architectural) shingles.

Underlayment: An approved underlayment (#15 roofing felt, #30 felt, or one of several proprietary products) is usually specified by shingle manufacturers. The underlayment should be installed in horizontal rows, with each course overlapping the one below by a minimum of 2 in.

Ventilation: Roof ventilation is a matter of dispute between code-enforcement officials, shingle manufacturers, and building scientists. Ventilation is required by many building codes and shingle manufacturers. A combination of eave and ridge vents is considered the most effective ventilation system. In recent years, some building scientists have advocated the use of a carefully sealed, unvented roof.

Low-slope roofs: Low-slope roofs require different materials and techniques.

Ridges and hips: Ridges and hips are covered in caps. These caps can be cut from standard three-tab shingles or come in the form of manufactured accessories. Ridge caps are often nailed over manufactured ridge-vent systems.

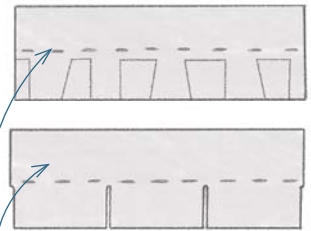

Two types: Most shingles today are either flat (usually three-tab) or laminated (often called architectural). In the United States, shingles are typically 36 in. long and 12 in. wide, although 1-meter by 1/3-meter shingles also are available.

Minimum pitch: Without an elastomeric membrane or double felt layer, minimum roof pitch is 4-in-12. Unless shingles are hand-sealed, the maximum pitch is 21-in-12.

Drip edge: Manufacturers recommend the installation of metal drip edge at eaves and rakes. The shingle roof should overlap the trim board or drip edge, if one is used, by 1/2 in. to 1 in.

Metal flashing: is used to treat seams between the roof deck and walls, chimneys, and skylights. Special-purpose flashings are used to treat the seams between the roof deck and pipes and vents.

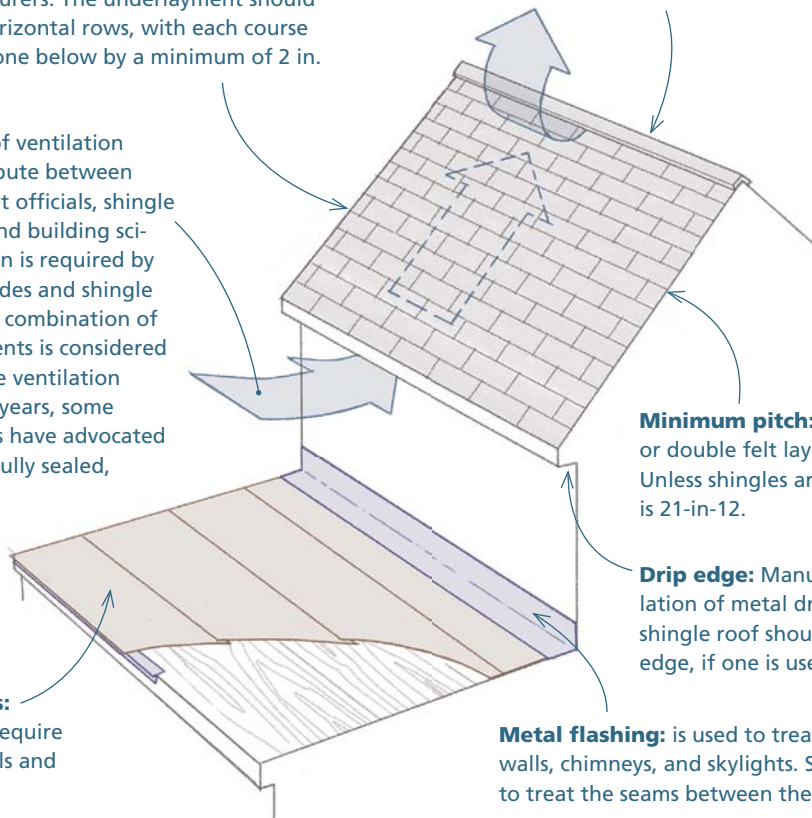

Asphalt Shingle Layout Basics

A shingle roof is laid out after the underlayment and drip edge (if used) have been installed. Layout includes careful measuring and then snapping a number of chalklines to guide shingle installation. The layout creates a shingle pattern that not only sheds water effectively but also serves an aesthetic purpose by keeping courses straight and uniform in size. That gives the completed roof a neat and professional appearance.

This section shows how to lay out the roof for standard 36-in. by 12-in. shingles. The same basic procedure is used for metric shingles, but the dimensions must be adapted slightly.

Here, the layout will be broken down into several steps for better clarity. In common practice, however, the layout consists of two steps: First, all the lines are measured and marked; then, all the chalklines are snapped at the same time.

Laying Out the Horizontal Courses

The layout for horizontal courses can be divided into three distinct parts: the layout for the starter course; the layout for the first course; and the layout for all the subsequent courses going up the roof.

There are two things that must be determined before marking the line for the starter course. First is how much the shingles will overhang the bottom edge of the roof deck (including the fascia and drip edge, if one is used). An overhang between $\frac{1}{2}$ in. and 1 in. is generally acceptable. Second is the width of the starter material. Prefabricated starter strips come in 7-in. and 10-in. widths. If these aren't available, you can cut the starter off the shingles you're using. For standard 3-ft. shingles, cut off the bottom 5 in. of the shingle to create a 7-in. starter strip.

In this example, the bottom edge of the roofing will extend $\frac{3}{4}$ in. over the bottom of the drip edge and a 7-in.-wide starter course will be used.

WAYS OF WORKING

When to Snap Chalklines

The distance between the layout lines varies from roofer to roofer. Some roofers snap lines every 5 in. so they have a chalkline to guide every course of shingles. Others might snap a line every 30 in., which provides a chalkline to guide every sixth course. The

choice of increment is not important on simple roofs, but it can be on complex roofs. As shown on p. 218, the right increment can help keep the layout consistent on roofs that must go over and around such obstructions as intersecting roofs and dormers.

STEP 1 Lay out the starter course

1 Hold a ruler flat on the deck, with $\frac{3}{4}$ in. extending past the bottom edge of the deck, and mark at 7 in.

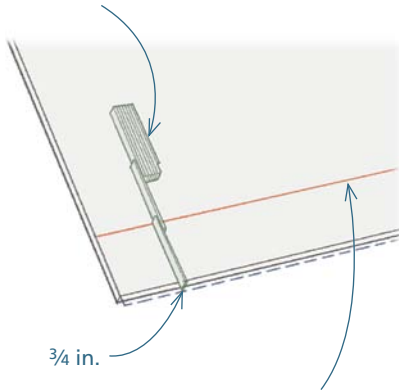

2 Do this at both ends of the roof, and strike a line from mark to mark.

STEP 2 Lay out the first course

Lay out the first course at the same time you lay out the starter course. As you hold the ruler with $\frac{3}{4}$ in. extending over the bottom edge of the roof, mark at 12 in. just after you mark at 7 in.

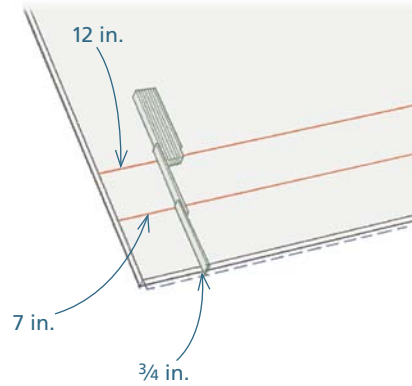

STEP 3 Lay out the rest of the courses

Lay out the rest of the courses from the first course mark. The increments must be in amounts that are equally divisible by the desired "exposure to the weather," often simply called the exposure. For a roof with 36-in. shingles, the required exposure is usually 5 in. Therefore, the distance between the horizontal lines, starting at the first course, can be any multiple of 5 in. apart, such as 5, 10, 15, 20, 25, and 30 in.

Hold the ruler so that the end is even with the first course line, and mark in the desired increments. In our example, the courses are marked every 10 in.

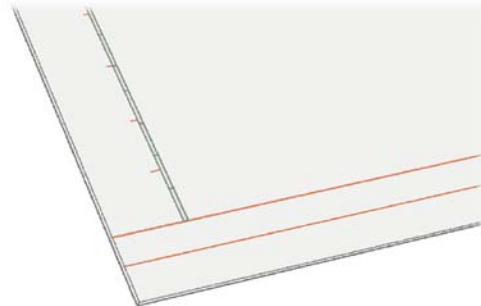

TOP TIP

A Ruler Works Best on Roofs

The best measuring tool on a roof deck is a ruler (either a 6-ft. folding carpenter's ruler or a large aluminum ruler). Unlike a standard tape measure, it isn't curved in cross section and it doesn't have an annoying hook at the end, which means it lies flat of the deck. And, because it's rigid, it can be held with one hand as you mark with the other.

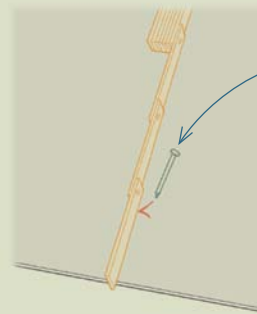

To mark measurements on roofing felt, use a nail to scratch a V-shaped mark.

Laying Out the Offset

To keep water from running into the seams on asphalt-shingle roofs, it's necessary to offset each horizontal course from the one below. In addition to this practical function, the offset plays an important aesthetic role. The offset creates a pattern that's visible from the ground and, where windows overlook sections of the roof, from within the house. If you fail to follow the manufacturer's offset specifications and/or install the pattern in a sloppy manner, the result can be a roof that is an eyesore.

Offsets for architectural shingles

Manufacturers of architectural shingles use multiple laminations to provide an irregular surface. This uneven surface, combined with shading patterns in the color, gives the shingles a textured look that suggests slate, wood shingles, or ceramic tile.

To achieve this look, however, you need to follow the instructions for offsetting the courses. These instructions differ with the type of shingle being used. It's important, then, to consult and follow the manufacturer's instructions, which are printed on the wrapper for each bundle.

Because the texture of architectural shingles is rough, the layout doesn't need to be as precise as it does for three-tab shingles. The layout for architectural shingles is usually accomplished by simply cutting off a specified amount during the installation. The drawings at right are for GAF Timberline® 30 shingles.

The layout for other brands of architectural shingles may be different. Make sure you read and understand the directions for the shingles you're using.

Three offsets for three-tab shingles The grooves of three-tab shingles are clearly visible from the ground, and the manner in which they line up can have a strong impact on the way the roof looks. The challenge in laying out the offset is to ensure that the grooves end up in a neat pattern that imparts a sense of order and craftsmanship.

STEP 1 Starter and first course

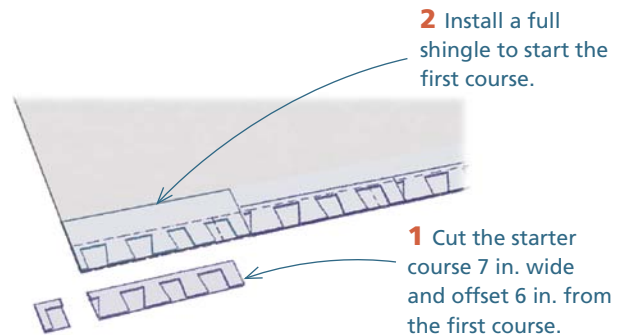

STEP 2 Second course

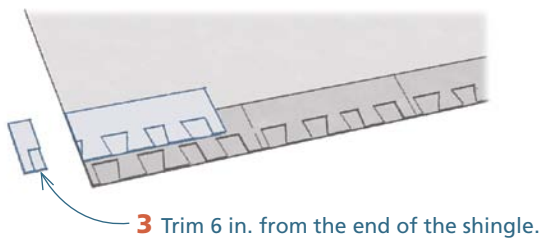

STEP 3 Third course

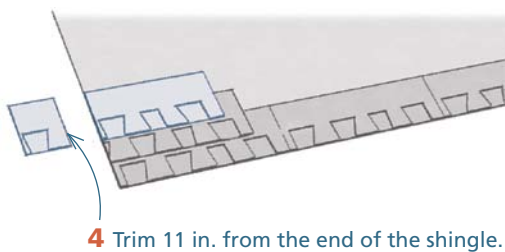

STEP 4 Fourth course

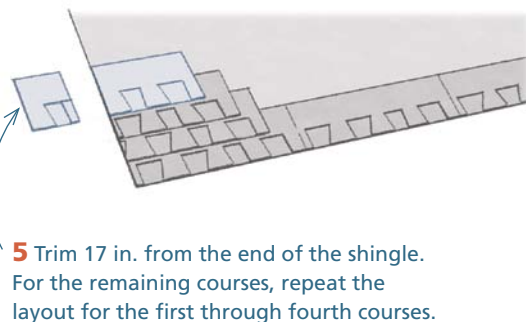

The most common offset for 36-in. three-tab shingles is the 6-in. offset, which places the offset in the middle of the tab of the shingle immediately below. In some regions of the United States (mainly in the West), roofers prefer the 5-in. offset. A 4-in. offset, which places the offset at the one-third point of the tab below, is less common.

● OFFSET AFFECTS APPEARANCE

Offsets between adjacent courses of 6 in., 5 in., and 4 in. all are used, and they each impart a different effect on the appearance of the roof.

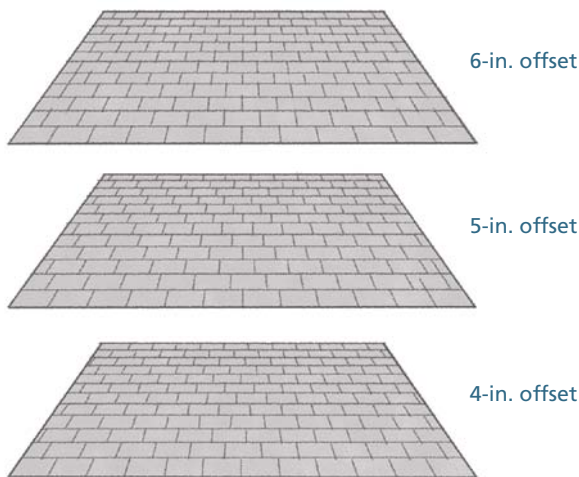

● LAYING OUT A 6-IN. OFFSET

1 Measure and mark two vertical bond lines that are 6 in. apart and parallel to one another.

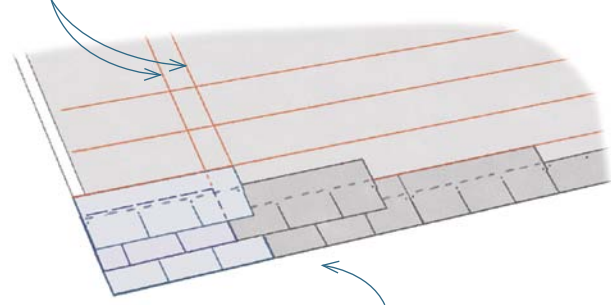

2 When you install the shingles, simply start each horizontal course on alternate bond lines to create the offset pattern.

● LAYING OUT A 5-IN. OFFSET

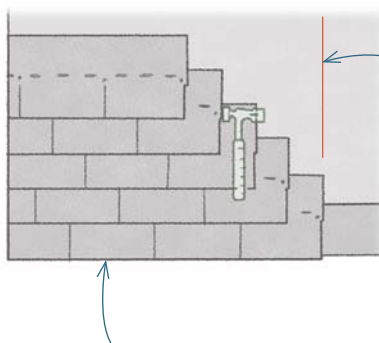

1 Measure and mark a single bond line.

2 After setting the first shingle of the first horizontal course on the bond line, use a gauged roofing hammer to line up the offset for the next course up. Make sure the gauge is set to 5 in. Hook the gauge of the roofing hammer on the edge of the installed shingle, and line up the offset for the next shingle up, as shown. Repeat the process for subsequent courses.

● LAYING OUT A 4-IN. OFFSET

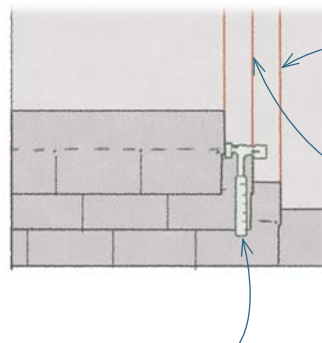

1 Measure and mark three bond lines 4 in. apart.

2 As you install the shingles, move over one line at a time to create the offset pattern.

3 You also can use a gauged roofing hammer with the gauge set at 4 in., using the same procedure as explained for the 5-in. offset.

Avoiding Undersize Tabs along the Rakes

Roofers often measure over from the rake to lay out bond lines. After making marks at the top and bottom of the roof, they strike chalklines between the marks and use those lines to guide the shingle offset.

In most cases, this works just fine. But once in a while, the final vertical row of grooves at the far end of the roof ends up very close to the rake. This leaves undersize tabs (less than 2 in. wide) along the rake at the far side of the roof. The tabs are unsightly and often tear off in the wind.

To avoid undersize tabs, use the procedure below:

This technique also works when using 4-in. offsets. However, you must divide half the width of the roof by 4 in. (the size of the offset). If the decimal portion of the result is less than 0.5, indicating that a shift is needed, move the baseline over 2 in. (half the width of the offset).

This technique does not work when using 5-in. offsets because the pattern does not have strong vertical alignment. (The grooves line up only every twelfth course.)

STEP 1 Mark what will be the center of the finished roof

STEP 2 Do the math

STEP 3 Adjust the centerline

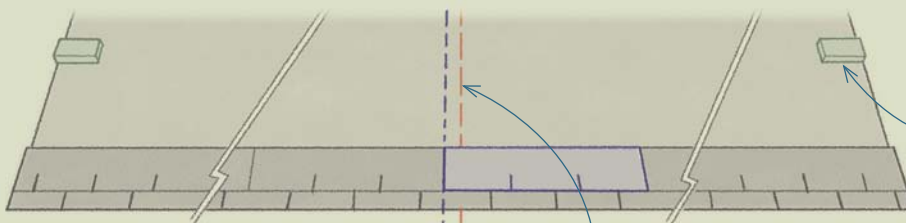
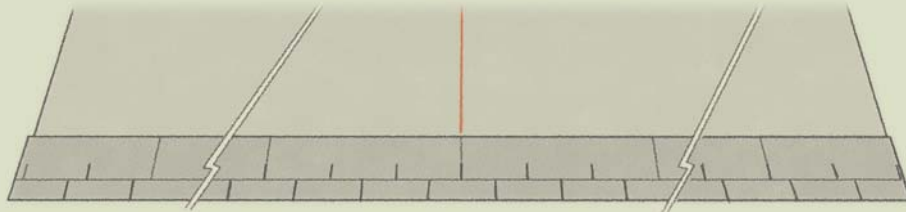

1 It's essential to take into account the overhang on the rakes. To do this, nail down a scrap of plywood with the end overlapping the edge of the rake board or drip edge, if one is used, the same amount that the finished roof will overlap the edge. After nailing down the scraps at both ends, find the center of the space between the outside edges of the two pieces of plywood. Note the distance from the outside of one of the scraps to the center mark and divide by 6 (the size of the offset).

3 If the decimal fraction at the end of the result is less than 0.5, shift the baseline of the layout over 3 in. (half the size of the offset).

2 If the decimal fraction at the end of the result is more than 0.5, leave the baseline of the layout in the center of the roof.

Maintaining the Offset Pattern When You Cross Obstructions

Sometimes a dormer, an intersecting section of the roof, or some other architectural feature interrupts the plane of a given section of the roof. When this occurs, it's essential to maintain a neat, consistent offset pattern on the far side of the obstruction.

With some architectural shingles, maintaining a consistent pattern is easy because the pattern is meant to be random. With these shingles, the roofer can arbitrarily pick a starting point at the bottom of the section on the far side of an obstruction. This simplified layout is a feature that many roofers like about architectural shingles.

However, not all architectural shingles are so forgiving. Some come with stricter offset rules, and it's essential to lay out the offsets in order to maintain the pattern on the far side of the obstruction. This also is true with three-tab shingles. Whether you're using a 4-in., a 5-in., or a 6-in. offset, maintaining a precise and consistent pattern on the other side of an interrupting element is essential to achieving a professional-looking job.

Anticipating the layout of offsets on the far side of obstructions When you install the shingles on a roof with valleys, dormers, and other interruptions, you have to pause during the installation and lay out the area on the far side of the obstruction. Because this layout comes in the middle of the installation phase of the job, it will be discussed in detail in the section on p. 218 on installing shingles.

Although you can't lay out those sections until you get to them during the shingling phase of the job, there is an important step you can take at the very beginning of the main layout that can greatly simplify the task of keeping the offset pattern consistent on the far side of an obstruction.

Most offset patterns are repetitive. They begin on a given bond line, then after a certain number of horizontal courses, they return to the original bond line and the process starts again. Before laying out the horizontal lines on the roof, look closely at the shingles you're working with and the offset pattern you're using. Determine how many courses it takes to return to the original bond line. Then, when you lay out the horizontal lines, make sure you mark these lines in a manner that distinguishes them from any other horizontal lines. This way, the shingles in every marked horizontal course will be on the same bond line.

SAFETY FIRST

Don't Leave Cap Nails Lying Around

.....

Unlike most other nails, a cap nail can come to rest on its head with the point of the nail sticking straight up. In this position, they are a safety hazard. If you drop any cap nails, pick them up immediately to prevent them from finding the bottom of someone's foot.

.....

● **TIMBERLINE 30 SHINGLES**

With the GAF Timberline 30 shingles, the offset pattern returns to the original bond line every fourth course. One way to distinguish these courses would be to simply mark horizontal courses every 20 in. and not use any other horizontal lines. You can line up the shingles for the three courses in between by eye or by using a gauged roofing hammer. If you prefer working with more horizontal lines, use a different color chalk for the courses in between the 20-in. lines.

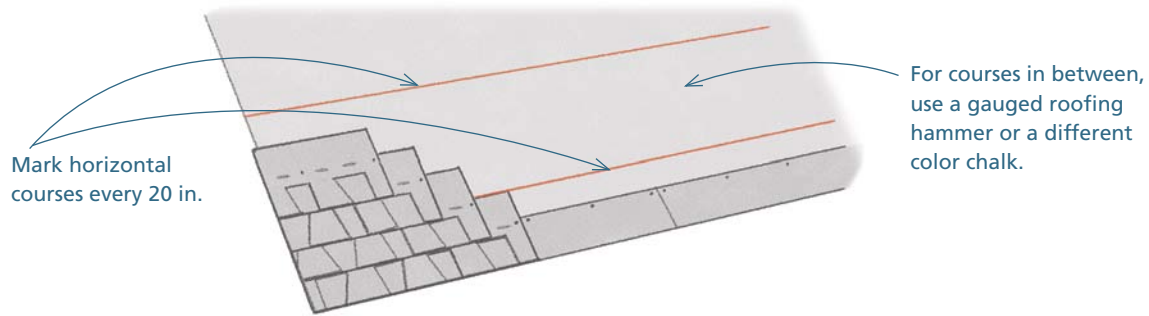

● **THREE-TAB, 6-IN. OFFSET**

Three-tab shingles, laid out with 6-in. offsets, return to the original bond line every other course. On these roofs, strike lines every 10 in. or 20 in.

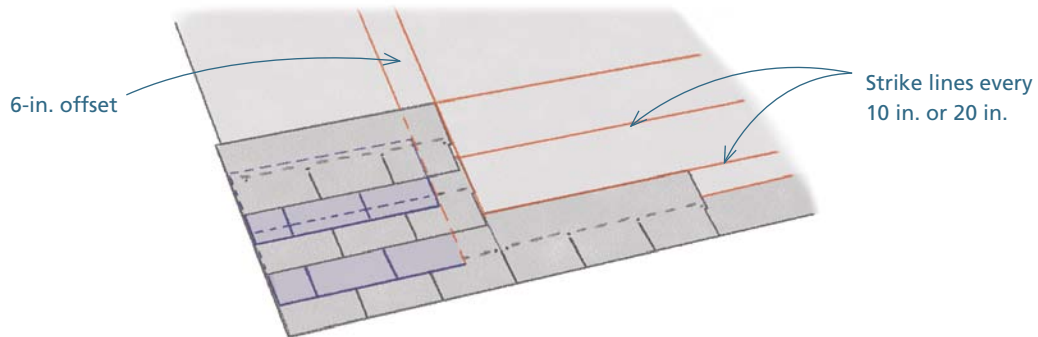

● **THREE TAB, 4-IN. OFFSET**

Three-tab shingles, laid out with 4-in. offsets, return to the original bond line every third course. On these roofs, strike lines every 15 in.

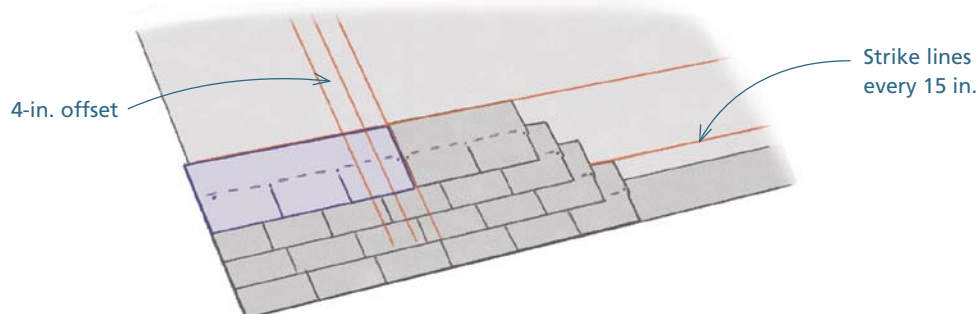

Installing Asphalt Shingles

While the details of layout vary for different styles of asphalt shingles, the installation is basically the same. Roofers apply the underlayment and drip edge (if one is used), lay out shingle locations and snap chalklines, and then apply the shingles.

In addition to cutting shingles to fit along the eaves and rakes, roofers often have to cut around pipes, vents, chimneys, and other obstacles in the plane of the roof. On some roofs, they also have to trim shingles to fit along walls. At each of these interruptions, they have to install flashing. When two roof sections intersect, there is a valley to contend with.

The finishing touch on the roof is the installation of the ridge caps. On hip roofs, these must also be installed along the hips. Sometimes this phase of the job also includes the installation of a ridge vent.

Installing Underlayment and Drip Edge

All shingle manufacturers recommend the installation of an approved underlayment and drip edge prior to the shingle installation. The drip edge along the eave should be installed before the underlayment, then the underlayment should lap over the drip edge. Along the rakes, the underlayment should be installed first and the drip edge should be installed on top of the underlayment. The exception is when you install a peel-and-stick membrane, such as Ice & Water Shield®, along the eaves. In that case, the membrane goes on first, followed by the drip edge. Should water back up along the eave in winter because of an ice dam, it won't be able to get beneath the membrane.

STEP 1 Install the drip edge

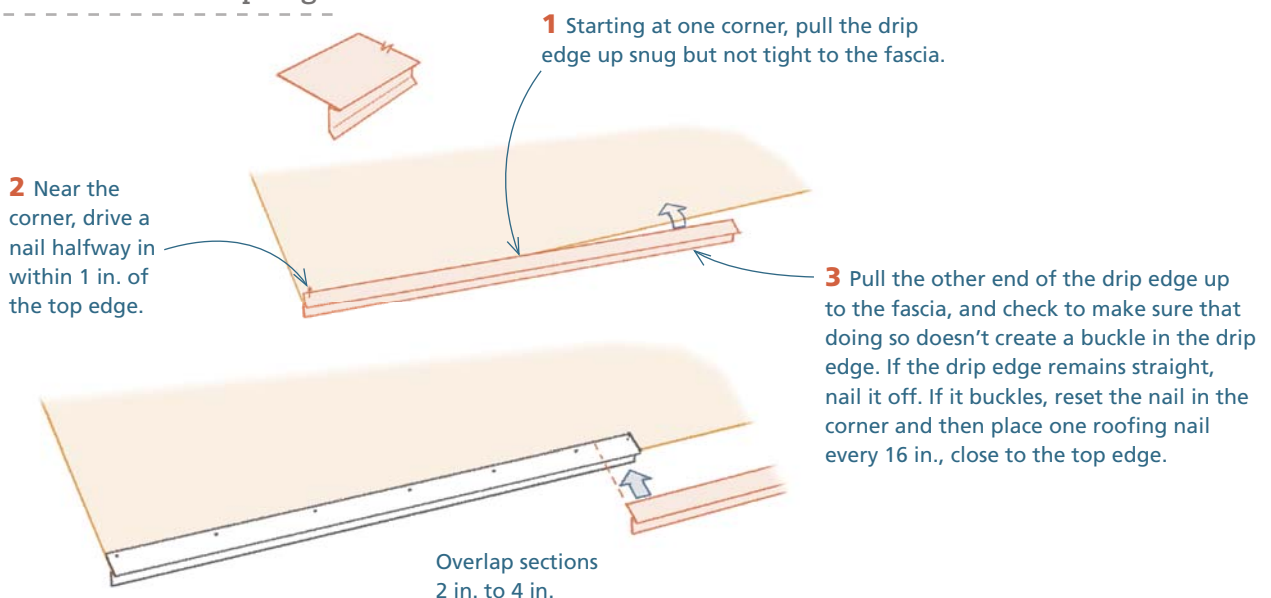

STEP 2 Install the underlayment

1 Place the roll so that the bottom edge is $\frac{1}{2}$ in. to 1 in. above the bottom edge of the drip edge. Starting at one rake, unroll about 3 ft. of the underlayment, and drive three or four nails near the center at the beginning of the strip. Placing nails in a tight pattern near the center will allow you to pivot the sheet up or down without buckling it when you align it with the bottom of the roof.

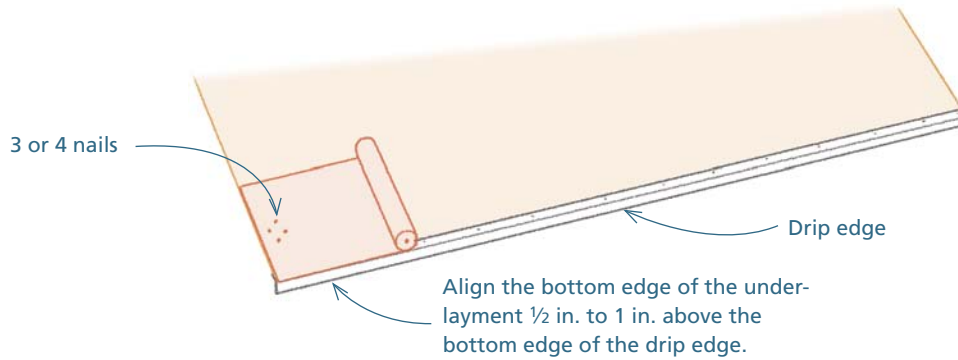

2 Unroll the underlayment about halfway across the roof. Align the bottom of the roll so that it's parallel with the bottom edge of the drip edge. Pull the roll to eliminate any wrinkles, and then nail the underlayment. Place three or four nails across the width of the underlayment. Continue unrolling the underlayment until you get to the end of the roof. Cut the piece at the rake, pull it taut, and nail it in place.

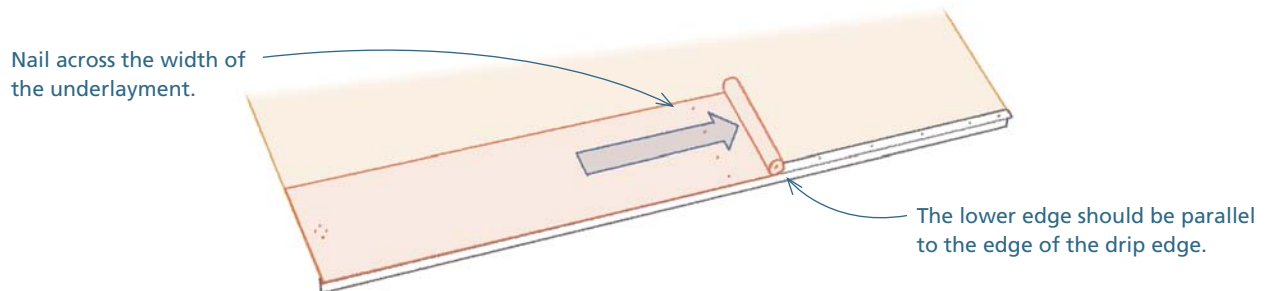

3 Add succeeding courses. Lap each course of underlayment 2 in. to 3 in. over the one below. If you're using roofing felt and expect to shingle the roof immediately after installing the felt, you need only put in enough nails to hold it in place. For synthetic underlayment, follow the manufacturer's instructions.

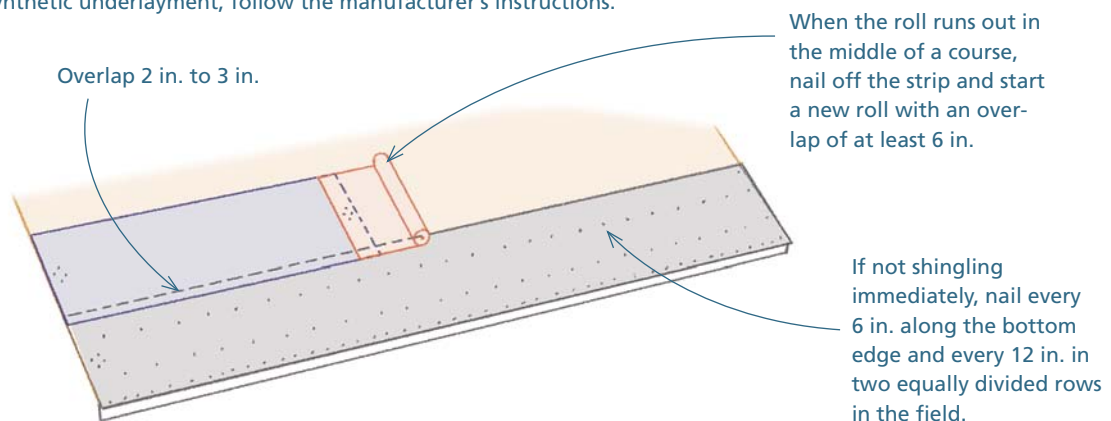

WAYS OF WORKING

Roof Underlayments

Roofing manufacturers and the National Roofing Contractors Association (NRCA) accept #15 or #30 asphalt-impregnated roofing felt as an underlayment for roofs with at least a 4-in-12 pitch. These materials, which have been in use for more than 50 years, have several shortcomings. They often stretch and buckle, especially after getting wet. The bubbles formed in the underlayment frequently telegraph through the finished shingle roof and detract from its appearance. Roofing felt also rips easily, both in the wind and underfoot. This weakness makes felt a poor temporary roof and presents a safety hazard to the workers installing the roof.

In recent years, manufacturers have offered two alternatives to standard felt. An improved fiberglass-reinforced felt has helped reduce the problems of stretching and tearing. These go by trade names such as Roofer's Select™ (CertainTeed) and Shingle Mate® (GAF).

Another alternative is a nonasphaltic or synthetic underlayment. These underlayments are up to seven times stronger than standard felt and, although waterproof, permit the passage of water vapor. These go by trade names such as Titanium® 30 (InterWrap) and Deck-Armor™ (GAF).

In areas subject to ice damming, designers often specify a peel-and-stick membrane for the first 3 ft. to 6 ft. up from the bottom edge of the roof. These membranes, sold under trade names such as Ice & Water Shield (Grace), StormGuard® (GAF), and WinterGuard™ (CertainTeed), also are used on vulnerable areas of the roof such as valleys and the area behind chimneys. They are also the best choice of underlayment for shingle roofs installed on slopes between 2-in-12 and 4-in-12.

Fasteners for underlayment

There are two types of fasteners commonly used for underlayment. For roofing felt, roofing nails are acceptable. If the underlayment will be exposed to the weather for several days, cap nails, which have metal or plastic heads that are about 1 in. wide, are often chosen because of their superior holding power. Cap nails are generally required when using synthetic underlayment.

STEP 3 Add drip edge to rakes

Starting at the bottom of the rake, position the rake-side drip edge so it runs over the drip edge on the fascia. Avoid pulling the drip edge so tight to the rake that it creates buckles. As you go up the rake, overlap succeeding pieces of drip edge 2 in. to 4 in.

Overlap the drip edge on the rake by 2 in. to 4 in.

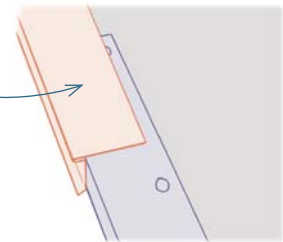

Installing the Shingles

After the underlayment and drip edge have been installed, the roof is ready to be shingled. This process begins by laying out the roof according to the specifications of the shingle manufacturer and snapping chalklines. After snapping lines, it's time to nail down the shingles and flash the penetrations of the roof plane. This section describes shingling with 36-in. three-tab shingles and a 6-in. offset. This procedure, with minor adjustments, can be applied to all types of asphalt shingles and to all offset patterns.

Getting started The layout of this roof consists of a starter course line at 7 in. and a first course at 12 in. with $\frac{3}{4}$ in. overhanging the drip edge at the eave. From the starter course line, horizontal course lines have been snapped every 10 in. The bond lines are laid out 6 in. apart and positioned so as to maximize the size of the tabs along the rake. They've been struck near the left rake of the roof.

STEP 1 Begin the starter course

Begin the starter course on the left bond line.

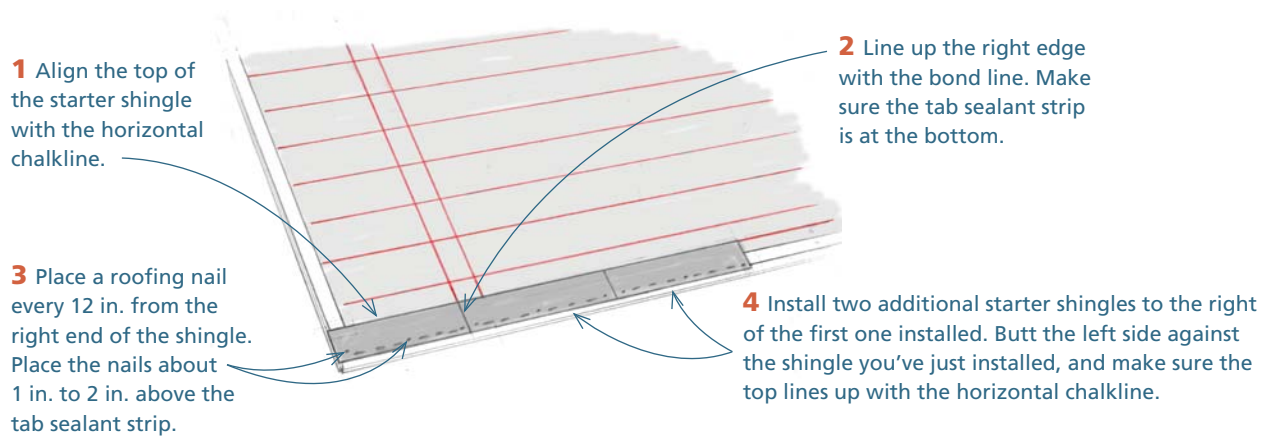

STEP 2 Begin the first full course

1 Begin the first full course on the right bond line. This shingle goes directly over the starter course.

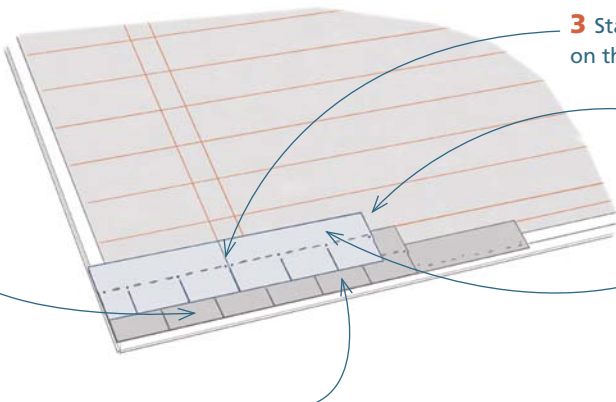

2 Line up the top with the 12-in. line, and make the bottom even with the bottom of the starter course. Install one additional shingle along the line to the right of the first one. Place one nail at each end and one above each of the two grooves in the shingles. The nails should be at least $\frac{1}{2}$ in. above the grooves and below the sealant strip. If there's not enough room to fit the nail below the sealant strip, place it in the nearest space between the sealant deposits.

STEP 3 Begin the second full course

3 Start the shingle on the left bond line.

4 Line up this shingle horizontally by eye or by using a gauged roofing hammer. To align the shingle by eye, set the bottom even with the top of the groove in the shingle directly below.

5 Install a second shingle to the right of the one just installed.

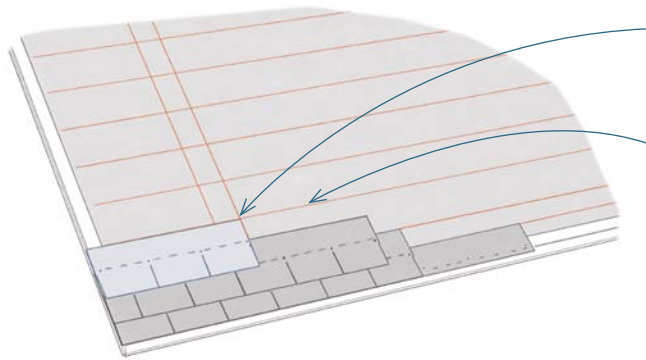
STEP 4 Begin the third full course

1 Align the shingle with the right bond line.

2 Align the top even with the first horizontal line. Notice how the two full shingles that have been placed on chalked horizontal lines have also been placed on right bond lines. This pattern, which will be repeated all the way up the bond lines, will make the layout of shingles on the far side of interruptions in the roof plane easier.

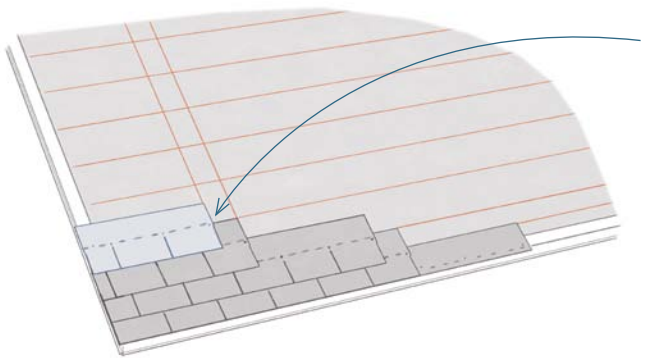
STEP 5 Begin the fourth full course

Start this one on the left bond line. Line up this shingle horizontally by eye or use a gauged roofing hammer. Begin the next diagonal row to the right of those shingles already installed. When you reach the top of the pattern, start a fifth horizontal course with the edge aligned with the right-hand bond line. Repeat this pattern to the top of the roof.

TOP TIP**Using a Gauged Roofing Hammer**

.....
Gauged roofing hammers can be used to lay out offsets or horizontal courses. To lay out horizontal courses, set the gauge to 5 in. (5⁵/₈ in. for metric shingles). Hook the gauge on the bottom edge of the shingle in the course below, and set the bottom of the shingle you're installing on the head of the hammer.

To lay out offsets, set the gauge to the desired offset. Hook the gauge on the top 2 in. of the end of the shingle in the course below. Slide the shingle up against the head of the hammer to set it at the proper offset.
.....

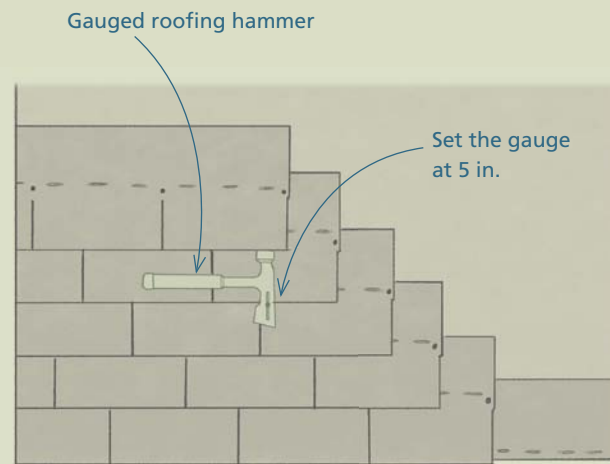

Three Installation Patterns

As you go up the roof, alternating between the two bond lines with each horizontal course, you can choose between three basic installation patterns.

METHOD 1 Running the shingles in horizontal rows

For most neophyte roofers, the easiest approach is to simply carry each course horizontally across the roof. After reaching the end of the roof, start the next course on the other bond line and then carry that course across the entire width of the roof. This pattern is simple but slow and tiring.

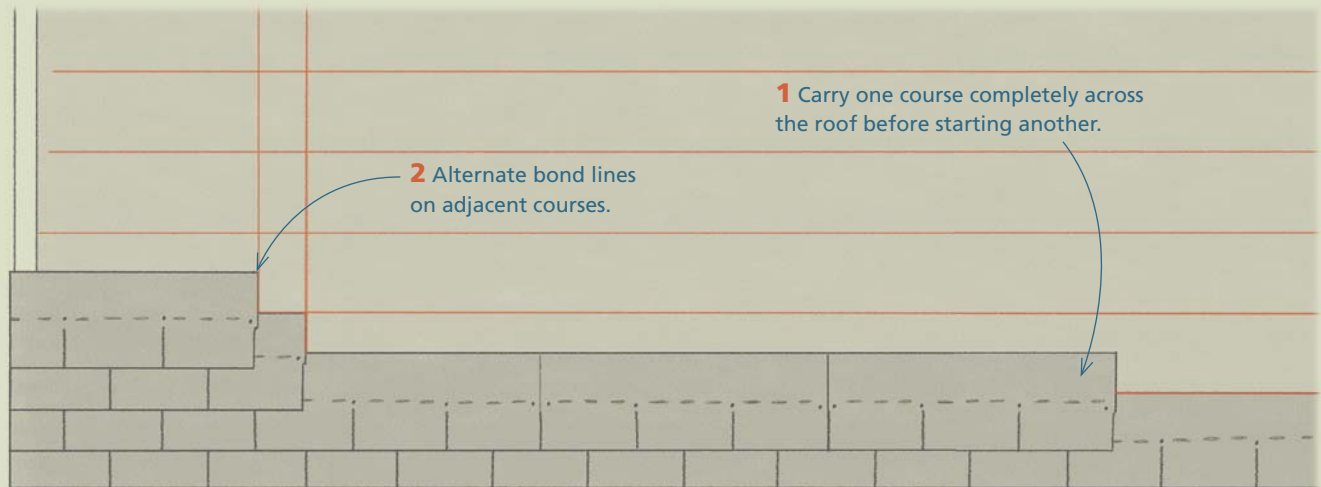

METHOD 2 Running shingles in a stair-step pattern

A second approach is to set up a diagonal, stair-step pattern as you go up the bond lines. To do this, you need to cut three-tab shingles into two-tab and one-tab shingles. This pattern is often recommended by shingle manufacturers for aesthetic reasons and because it blends colors effectively. It can be efficient on long sections of roof, less so on short sections. It is not the best choice for roofs cut up by dormers and intersecting roofs.

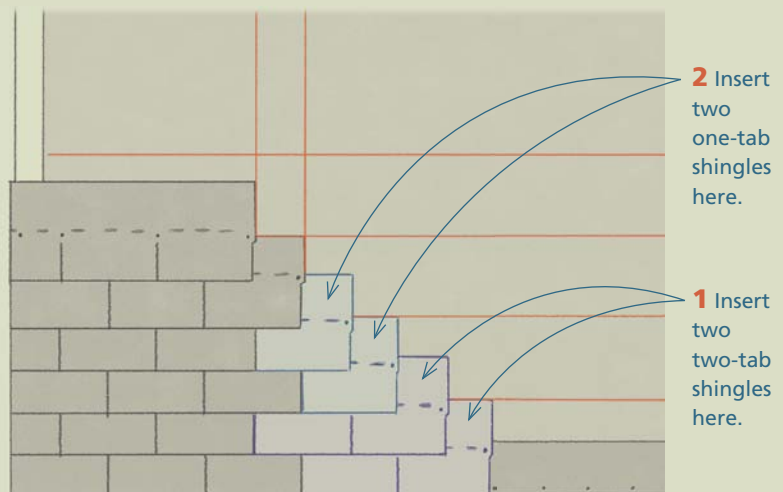

METHOD 3 Running shingles up in vertical rows (racking)

The third approach is to run the shingles up in vertical rows, a process called racking.

This installation pattern can't be used for many architectural shingles. For three-tab shingles, this pattern is popular among professional roofers for three reasons: It is the fastest installation method for most roofs; it reduces the chance of scuffing shingles on hot days; and it simplifies the process of keeping the offset pattern consistent on the far side of obstructions on the roof.

Some manufacturers, however, caution that racking the shingles can cause less than optimal color patterns in the finished roof. Other concerns are that shingles can be damaged as tabs are lifted on every other row and that nails might be forgotten. These concerns, however, are often overstated. And it's worth noting that the manufacturers of some architectural shingles require a racking installation pattern.

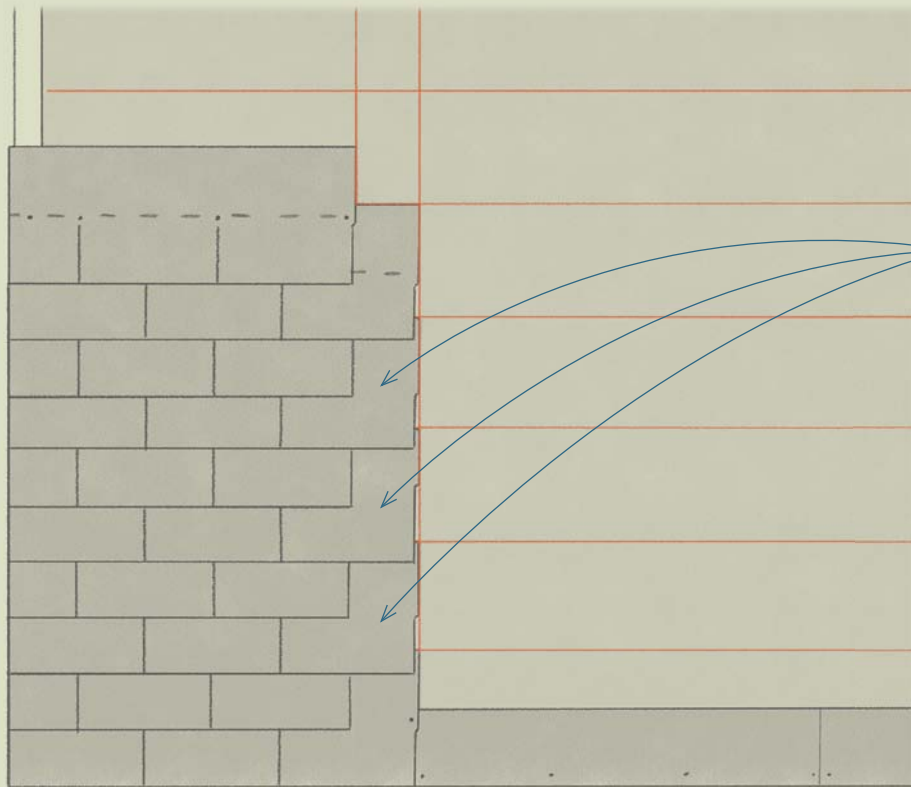

Leave out the fourth nail on every other shingle so that the shingles in the next vertical row can be slid under the overlapping half-tab. Drive this nail after sliding the shingle into place.

Cutting and Fitting Shingles

Every shingle roof requires a lot of cutting, and the ability to make these cuts quickly and accurately is an essential skill.

Tools for cutting shingles: The two basic tools for cutting three-tab shingles are a utility knife with a straight blade and a utility knife with a hook blade. For thick architectural shingles, it's often easier to use a pair of snips. In addition to these generic tools, professional roofers sometimes invest in special shingle-cutting tools. These work like a guillotine-style paper trimmer.

Cutting techniques: You will often need to cut shingles before they're installed. This is the case when you need to cut full shingles into starter courses, for example. The easiest way to cut these pieces out of three-tab shingles is to cut from the backside of the shingle. Using a utility knife with a straight blade, cut a line partway through the shingle, then bend and break the shingle along the incised line.

For architectural shingles, use a knife with a hook blade or, if this proves difficult, a pair of snips.

• JIGS AND TOOLS FOR ACCURATE CUTS

To cut starter shingles out of three-tab shingles, follow these steps:

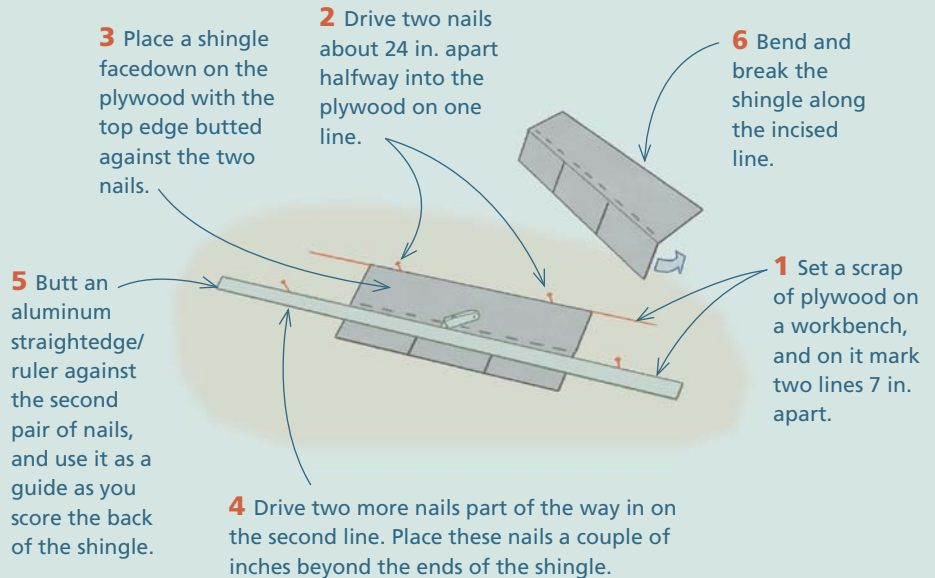

• TO CUT CAPS

For cutting either caps or one- and two-tab shingles from full-length three-tab shingles, follow these steps:

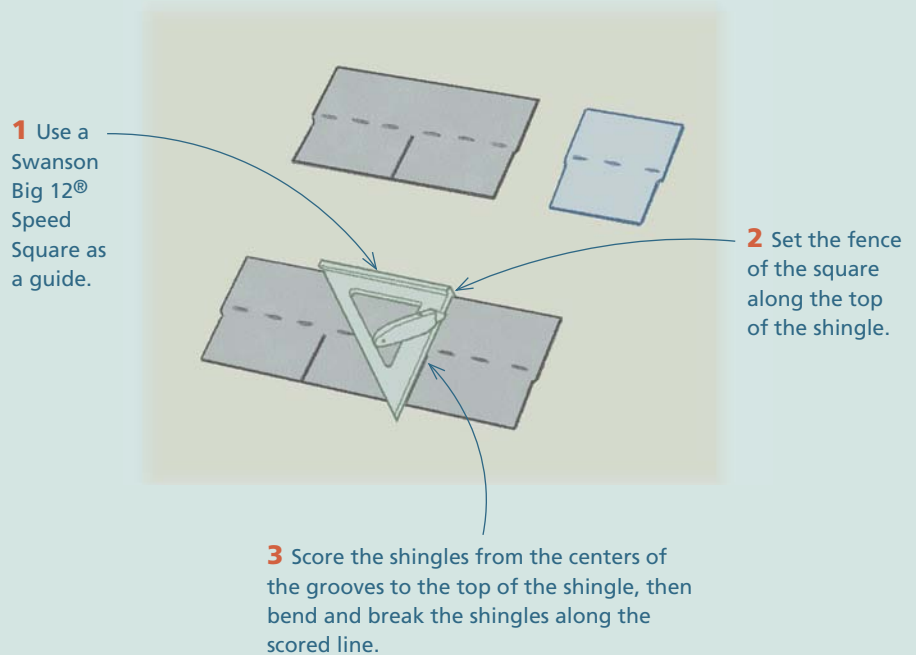

● CUTTING SHINGLES TO FIT

To cut a shingle to fit against a wall:

1 Place the shingle facedown with one end butted against the wall and the other end overlapping the last installed shingle in the course.

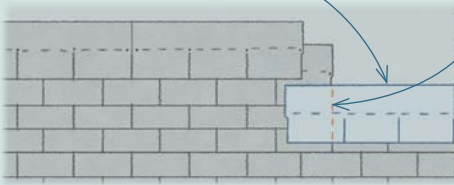

2 Mark the top of the shingle about 1/4 in. short of the end of the installed shingle. Take the shingle out and cut it at the mark, using a Big 12 square as a guide.

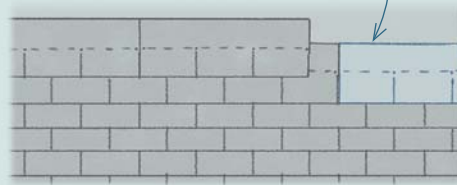

3 The cut shingle should fit and the offset pattern should remain consistent.

● CUTTING RAKES

1 Run shingles long, then snap a chalkline 3/4 in. out from the drip edge.

2 Starting at the top of the rake, use a knife with a hook blade to cut along the line. Avoid hanging more than 12 in. of shingle over the edge.

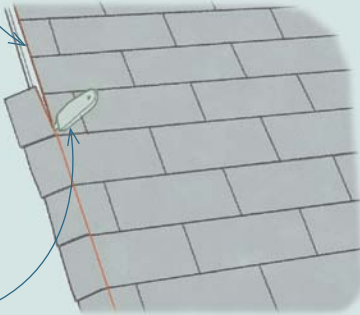

● CUTTING VALLEYS

1 Run the shingles over the valley, then snap a line.

2 Starting at the top, use a knife with a hook blade to cut along the line. (The location of the line varies. For more, see the section on cutting valleys on p. 216.)

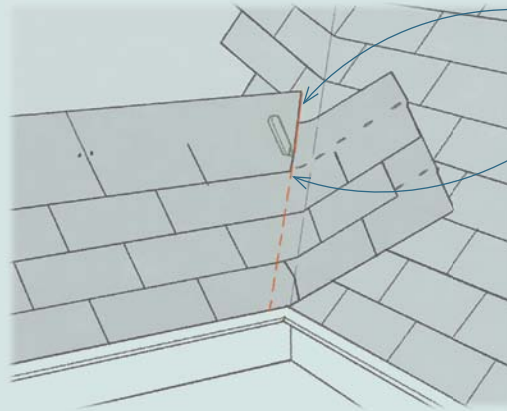

● CUTTING AROUND VENTS AND PIPE FLANGES

1 Set the shingle as it will be oriented horizontally, and mark the end at the height where it will have to be cut.

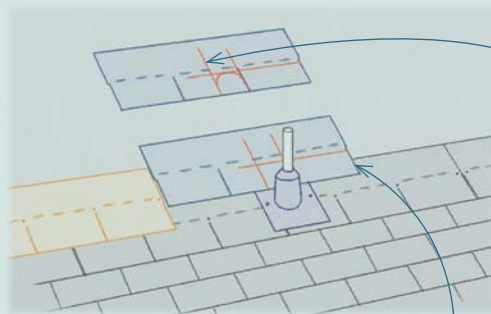
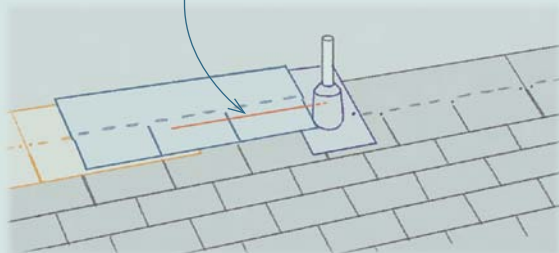

2 Set the shingle above the pipe or vent, placing it so that the end butts against the last shingle installed in the horizontal course. Mark the bottom at the points along the length where the shingle will have to be cut.

3 Extend lines from these points to lay out the height and width of the cut. If you need to round the corners, do so by eye. Cut the shingle with either a hook blade or snips.

Flashing Materials

A variety of sheet metals are used for flashing; some are available in precut and prebent versions.

Prefabricated pipe and vent flashing assemblies also are widely available.

GALVANIZED AND TERN-COATED STEEL

- Most common flashing metals in this country for generations
- Will rust if not maintained with paint or other protective coatings
- Used less frequently today

ALUMINUM

- Most common flashing material today

- Resists corrosion without a protective coating
- Corrodes when embedded in wet mortar

LEAD

- Popular in tradition-bound New England
- Highly resistant to corrosion
- Easy to cut and bend

COPPER AND STAINLESS STEEL

- Used mainly on upscale jobs
- Very durable but expensive

PREFABRICATED FLASHINGS

- Flashings for pipes and vents made from aluminum, coated steel, copper, stainless steel, and plastic

Installing Flashing

On shingle roofs that have at least a 4-in-12 pitch, few problems occur in the field. Most leaks occur in the valleys formed when two roof planes intersect, or in the seams where the roof meets a vertical surface, such as a wall, a pipe, or a vent. In all these locations, roofers rely on metal and plastic flashing.

How flashing works Flashing has two main purposes. First, it serves as a barrier that covers the crack between the roof deck and the wall, pipe, or other object that breaks the plane of the roof. Second, flashing channels water out and away from parts of the building that are vulnerable to water damage. Like shingles, pieces of flashing should be installed in an overlapping pattern, with the upper piece always lapping over the lower piece. The pieces of flashing, furthermore, should be woven into the overlapping pattern of the shingles. The object is to get water that flows over a piece of flashing to spill out on top of the roof. To do this, visualize how the water will flow and follow this simple rule: The bottom of the flashing should always run out on top of a shingle.

Flashing pipes and vents Pipe and vent flashings work by channeling water around a raised part of the flashing and out over the roof.

STEP 1 Run shingles up and around the pipe or vent opening

In most cases, the first two horizontal courses after you reach the pipe or vent opening should be cut and fit around the pipe or opening.

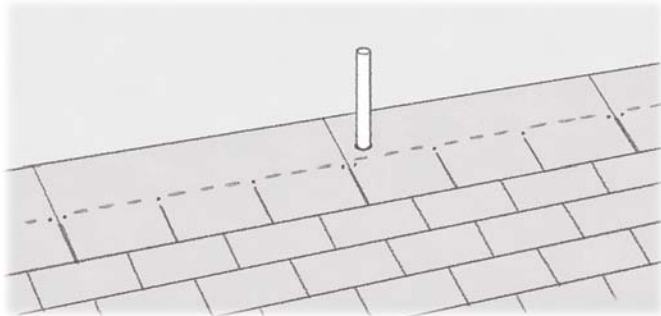

STEP 2 Check the fit of the flashing

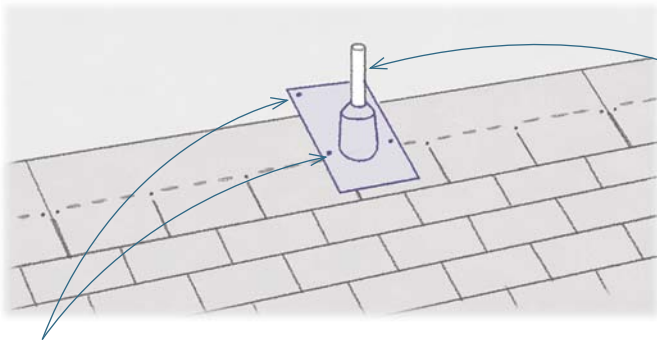

1 If you're installing a pipe flange, slip it over the pipe to check the fit. If it's a vent flashing, position it over the opening as it will sit when installed. If the bottom of the flashing extends down to the exposed portion (the lower 5 in.) of the last shingle installed, you're ready to install the flashing. If the bottom of the flashing doesn't reach the exposed portion of the shingle, fit and install one more shingle.

2 Nail the pipe or vent flashing securely in place. Place the nails near the four corners. In doing this, anticipate where the grooves in the shingles above will be, and make sure you offset the nails to keep them from being exposed in the groove. Make sure nails in the lower part of the flashing will not be exposed.

STEP 3 Install shingles around the flange

1 Cut and install the shingles around the pipe flange or vent flashing, using the method described in the section on cutting shingles on p. 205.

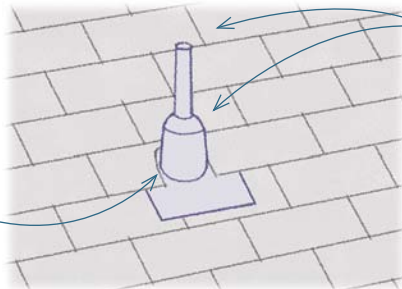

2 After cutting the pieces that go over the flashing, resume shingling up the roof in the normal fashion.

TOP TIP

Keep Seams away from Flashing

Once in a while, the seams between the shingles in a course will land on a pipe or vent opening. You can easily move the seam over by using a one-tab or two-tab shingle for the last shingle before the pipe or vent opening. After installing the shortened shingle, install a full shingle to straddle the pipe or vent opening. After installing the full shingle, install the tab or tabs you cut off to get back to the original installation pattern.

1 The seam lands directly on the pipe.

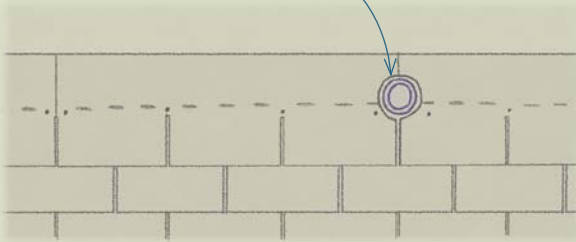

2 Use a one-tab or two-tab shingle for the last shingle before the pipe or vent opening.

3 Install a full shingle to straddle the pipe or vent opening.

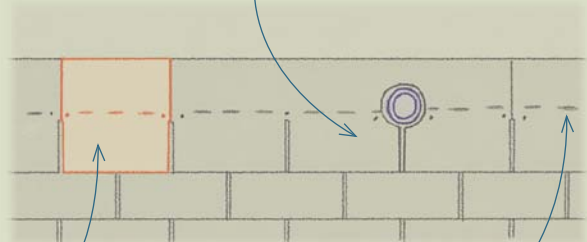

4 Install the tab or tabs you cut off to get back to the original installation pattern.

Flashing walls At the roof/wall juncture, builders install flashing first and then lap the siding over the flashing. This assembly works like a shower curtain, depositing the water on the outside of the flashing, where it can run safely down the roof.

There are three kinds of flashing used to flash roof/wall junctures. On walls located above a section of the roof, such as the front of a dormer, apron flashing is used. On walls located on the side of a section of the roof, such as the side of a dormer, step flashing is used. On short walls below a section of the roof, such as the uphill side of a framed chimney, a wide piece of flashing is used. This flashing is sometimes called a header flashing, but, more commonly, it's simply referred to as the back piece of flashing.

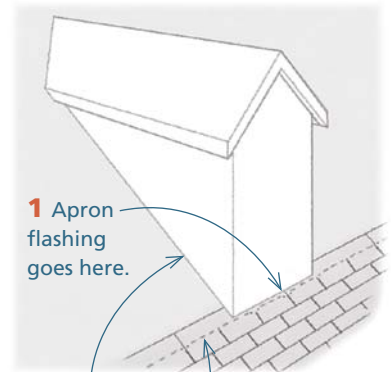

1 Apron flashing goes here.

2 Step flashing goes here.

3 Run the shingles up to and around the bottom side of the wall. Stop when the bottom of the apron will extend into the exposed portion of the shingle.

Installing Apron Flashing

Apron flashing comes in long pieces bent in a roughly L-shaped profile. A small turned-down lip at the bottom is added to keep that edge straight and to fit tightly against the roof. Ideally, the horizontal leg of the L would be bent to match the pitch of the roof; in most cases, however, it's bent at an average pitch (about 6-in-12) so that the same piece can be used for a variety of roof pitches. The biggest challenge in installing apron flashing is where the roof goes up and around the corner of a wall.

1 Hold the apron in place with about 4 in. running past the corner of the wall. Using a felt-tipped pen, scribe the back of the apron along the sidewall.

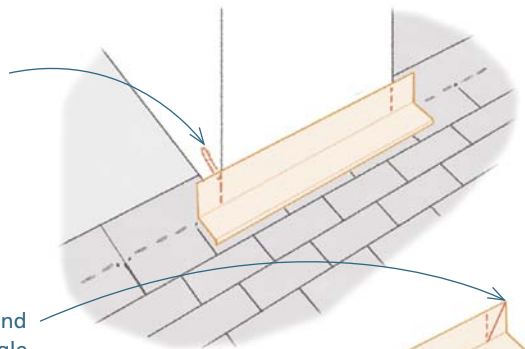

2 Take the apron out, and cut the top leg at an angle about halfway between the scribed line and the bend in the flashing.

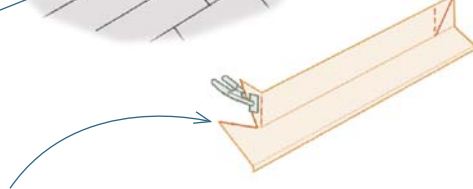

3 Use a pair of hand seamers to bend the top leg at the line. This part will wrap around the wall. Bend down the section below the cut so that it will lie flat on the roof.

4 Install the apron so that it fits snug against the wall. Make sure that the bent section wraps tightly around the corner.

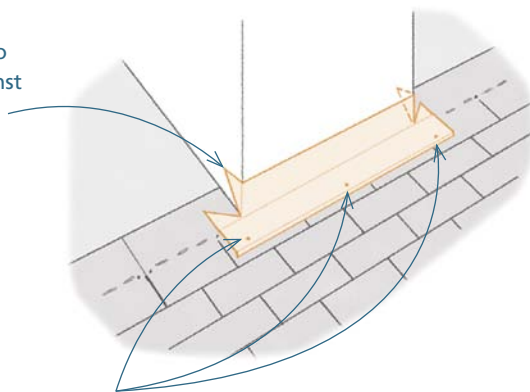

5 Drive one roofing nail every 24 in. through the lower leg of the flashing to fasten the apron. If the wall is longer than the piece of apron flashing, overlap the next piece at least 4 in. The nails holding the apron, which will be exposed, must be coated with sealant.

Installing Step Flashing

Precut step flashing comes in two sizes: 5 in. by 7 in. and 7 in. by 7 in. The smaller size generally works fine and is less expensive. Many roofers, however, are willing to pay the small difference in price for the larger pieces, which provide greater protection.

● INSTALLING THE FLASHING

1 Check that the first piece of step flashing will fit tightly around the corner. Squirt a bit of caulk in the corner, and put the flashing in place over the glob of sealant. Place one nail in the outside corner.

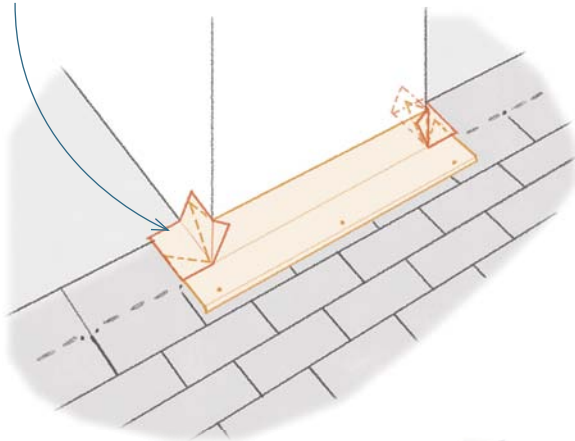

2 Cut and install the next shingle over the flashing. Make sure that seams between shingles do not land under or near the step flashing.

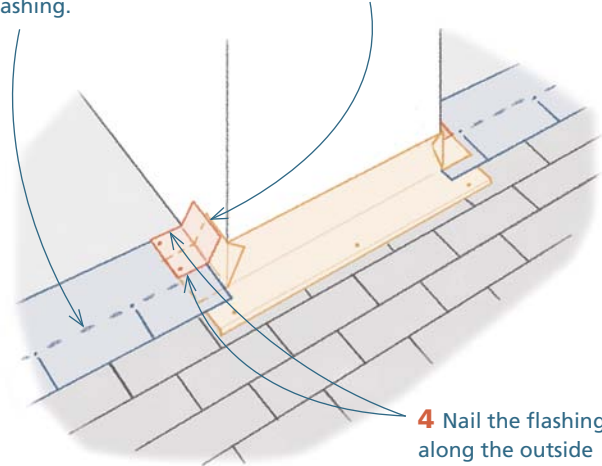

3 Install the next piece of flashing over the shingle. Place the bottom of the piece of step flashing just above the top of the exposed area of the shingle.

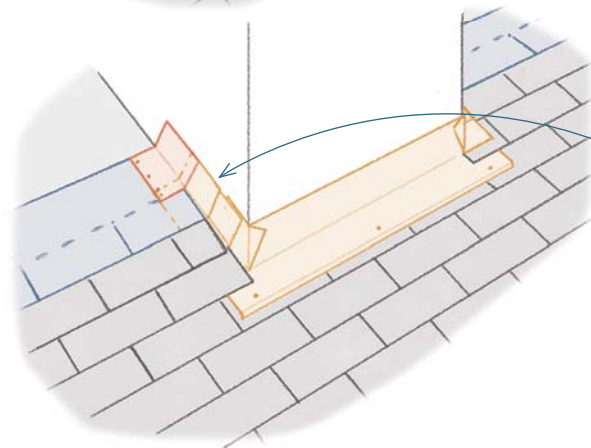

5 Repeat the process all the way to the top of the roof/wall juncture.

4 Nail the flashing along the outside edge about 2 in. up from the bottom.

Step flashing is available in flat, unbent pieces or as pieces that have already been bent. Prebent pieces are well worth the small mark-up in price, both because they save time and because the crisp, right-angle bends fit tighter in the roof/wall intersection, reducing the chance of wind-blown rain from going under the flashing.

At the top of the wall, there are three possible scenarios: the wall will terminate under the rake overhang of an upper roof; the roof will end before the wall and terminate at a ridge; or the roof will go around a corner in the wall and up the back of the structure.

● THE WALL TERMINATES UNDER A RAKE OVERHANG

When the rake overhangs the wall, flash the seam where the underside of the rake joins the lower roof.

1 Cut the step flashing to fit under the eave.

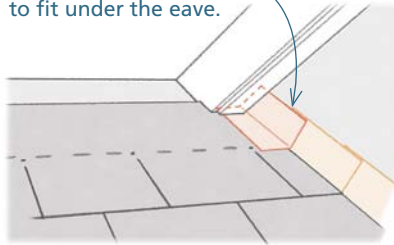

2 Install apron flashing over the last piece of step flashing along the wall. Cut the flashing, and fold up one tab over the subfascia.

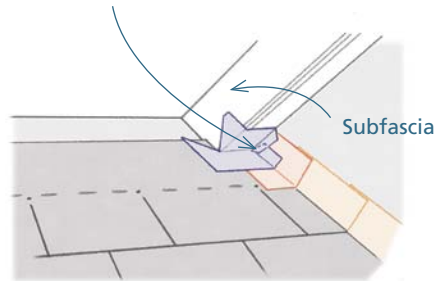

3 Install a piece of step flashing on the subfascia of the upper roof, with the flashing cut so one leg folds over the edge of the apron flashing.

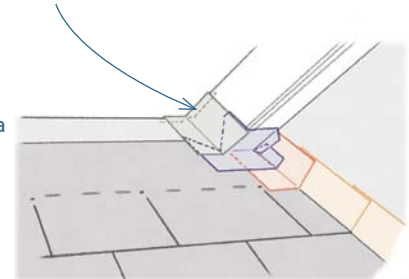

● THE ROOF PEAKS BELOW THE TOP OF THE WALL

1 Cut a piece of step flashing, and fold it over the peak.

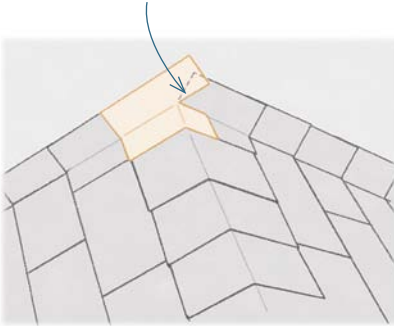

2 Cut and fold a second piece of step flashing to cover the peak from the opposite direction.

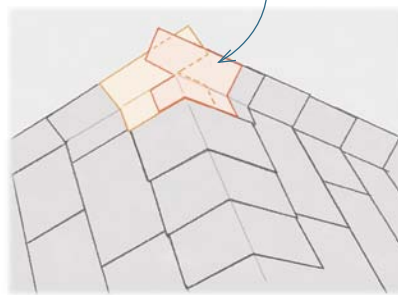

● THE ROOF GOES AROUND A CORNER

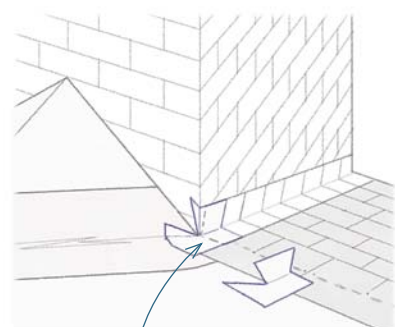

1 Cut and bend flashing around the corner in the same manner as described for the lower corner.

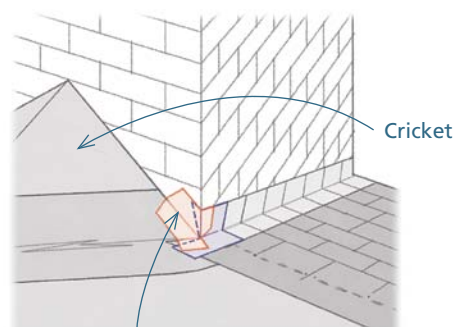

2 Cut and bend a second piece of flashing to cover the first. Before installing, put a dab of caulk at the corner.

Installing Back-Piece Flashing

On chimneys, skylights, and other square structures that rise above the roof plane, the back is a barrier to the free flow of water down the roof. In addition to using a peel-and-stick membrane in the area behind a chimney or other structure, there are two basic strategies for flashing. You can use a wide back piece of flashing, or you can build a cricket.

Using a back piece is simple and cheap—but it's not as effective as a cricket. When you use a cricket, water runs down valleys formed by the roof/cricket intersection and spills out on both sides of the chimney. Methods for building and flashing a cricket are discussed on p. 222.

Although back pieces work on narrow chimneys, you shouldn't use them on chimneys wider than 24 in.

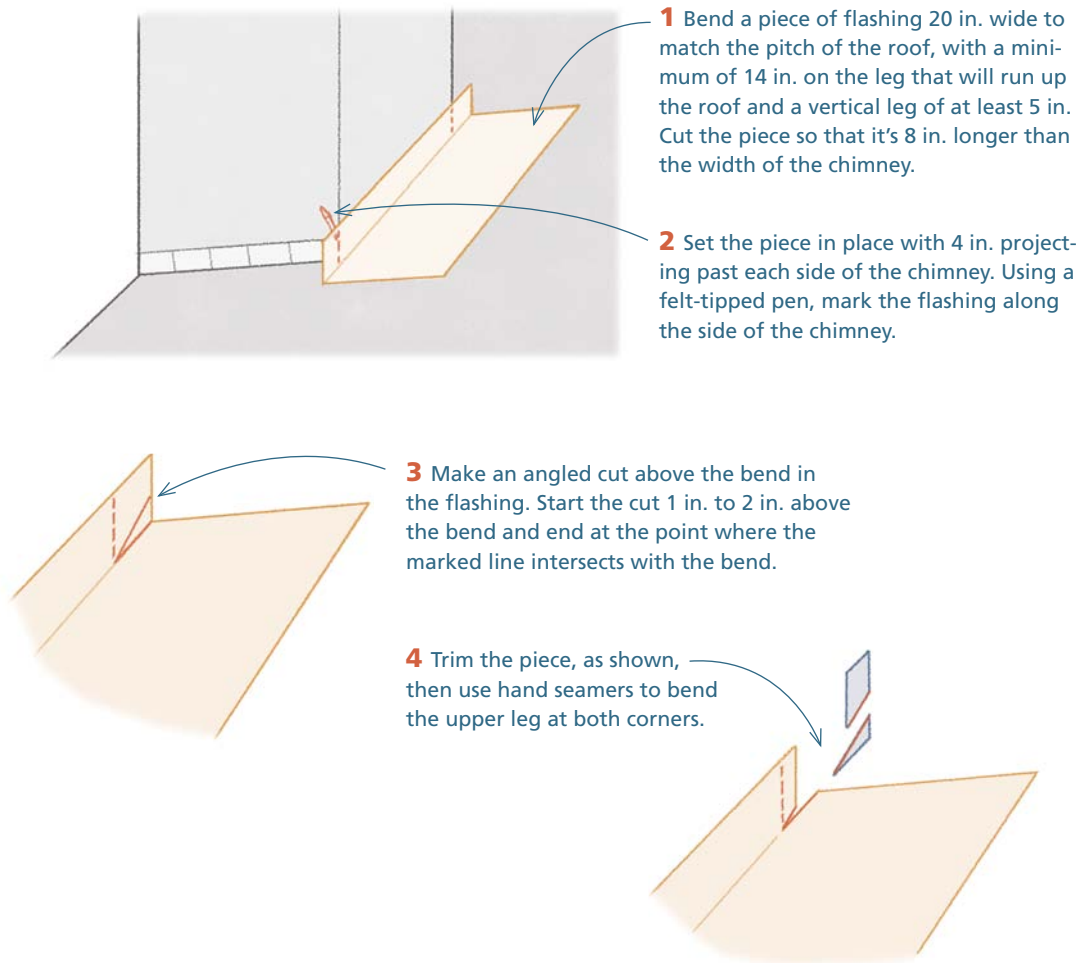

5 Install the flashing, overlapping the shingles and step flashing on the sides of the chimney.

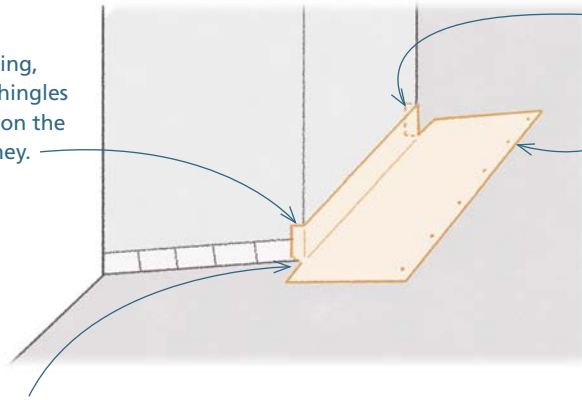

7 Place the nails in the upper part of both legs.

6 Squirt some sealant under the corners just before you install the back piece.

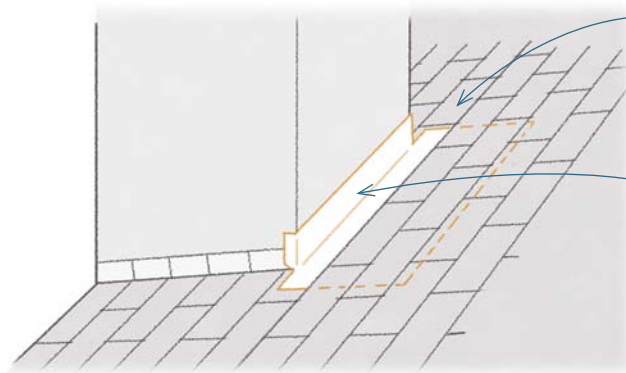

8 Install shingles over the back piece.

9 It's not necessary to install the overlapping shingles tight to the chimney. Leave a couple of inches of clearance to aid water movement.

Installing Valleys

Three valley treatments are commonly accepted for asphalt-shingle roofs: metal valleys (often called open valleys), woven valleys, and closed-cut valleys. Any of these options can be used to install a secure, trouble-free valley. Most manufacturers recommend the use of peel-and-stick underlayment under valleys.

Installing a metal valley Although roofers often simply cover the valley with metal from a roll, a proper metal valley should be shaped to keep water from migrating over the sides, as shown in the top drawing on p. 214.

● **METAL VALLEY PROFILES**

Prebent valley flashing typically comes in 10-ft. lengths and is available at roofing-supply houses or through sheet-metal shops (you won't find it at big-box stores).

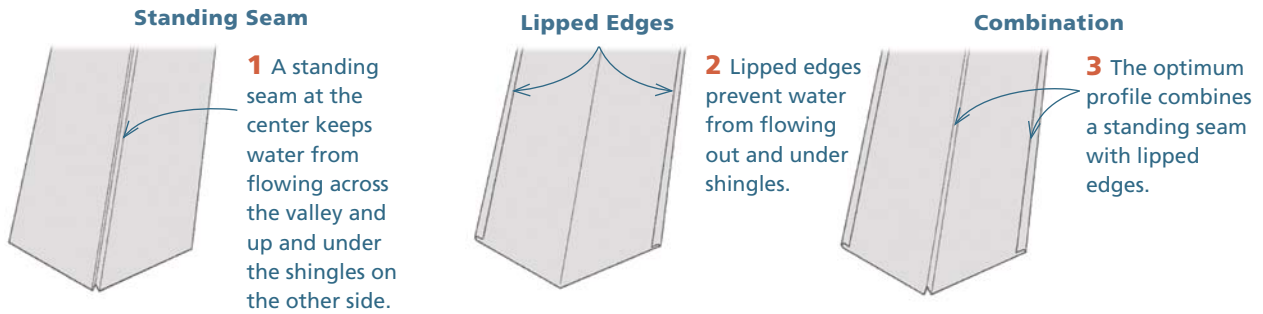

● **INSTALLING A METAL VALLEY**

STEP 1 Install the starter course on both sides of the valley so one piece overlaps the other

STEP 2 Cut the bottom of the valley to fit the eave

STEP 3 Install the valley

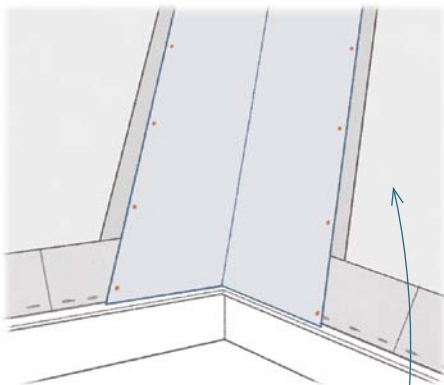
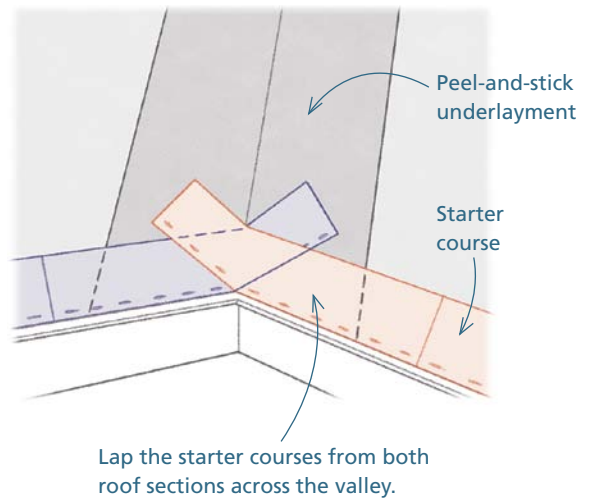

If the valley has lips at the edge, drive nails just outside so the nail heads hold the valley in place.

If the valley does not have lips along the edges, nail in the outer inch of the valley. Where more than one piece of valley flashing will be used, you may nail through the field of the valley in the top 4 in.; these nails will be covered by the next piece.

STEP 4 Overlap the next piece, if needed, by at least 5 in.

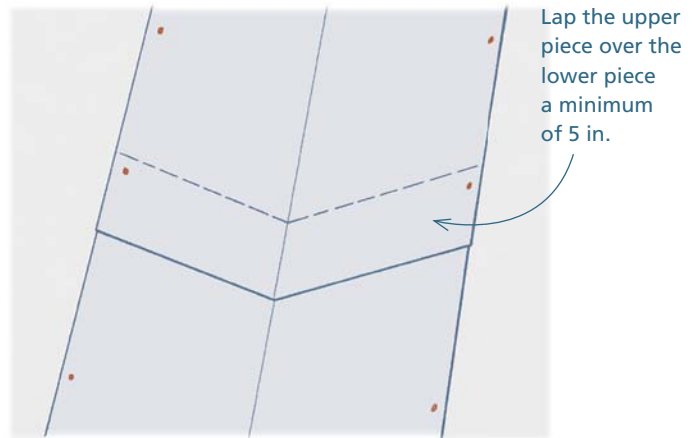

STEP 5 Fit the top of the valley

1 Cut the valley 10 in. above the intersection of the ridge and main roof.

2 Cut the half of the metal valley that rests on the lesser roof about 4 in. above the ridge.

3 Trim the overlapping 4-in. piece at an angle, as shown. Stop at the point where the framed ridge meets the center of the framed valley.

4 Fold one piece over the ridge, and let the other lie flat on the roof deck of the main roof.

5 Repeat the process on the other valley, cutting and folding the flashing the same way.

6 Before you nail the second valley in place, squirt a dab of sealant under the flap that folds over the first. Keep nails out of exposed areas of the valley.

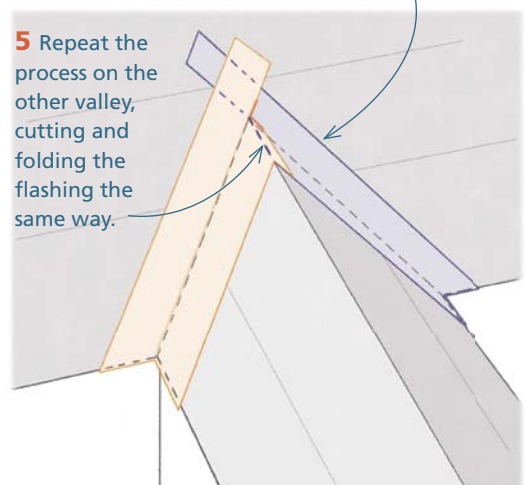
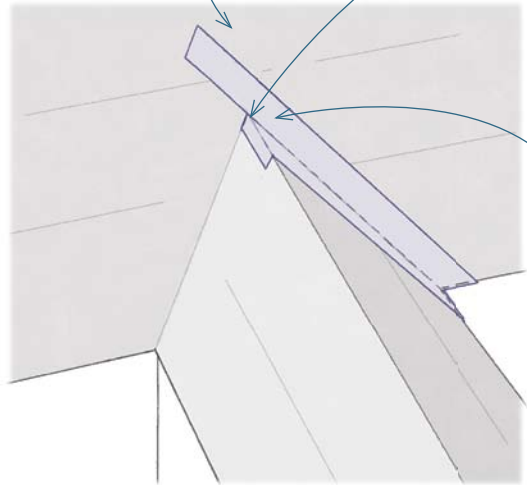

STEP 6 Run full shingles into the valleys

Do not nail through the valleys; nail only outside the edges of the valleys.

1 At the top of the valley, measure and mark the shingles 2 in. from the centerline of the valley.

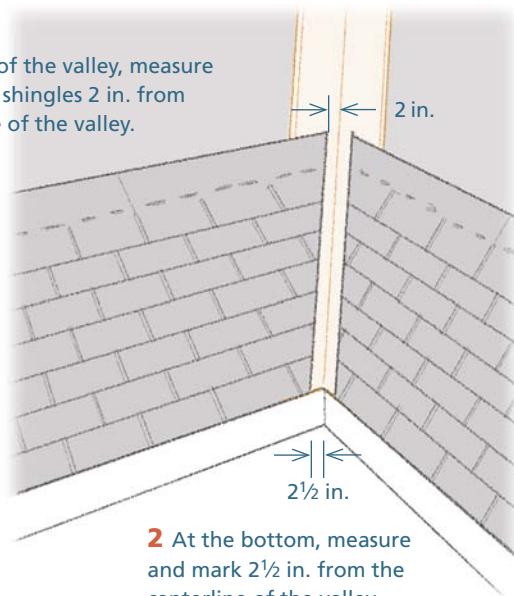

2 At the bottom, measure and mark 2½ in. from the centerline of the valley.

3 Snap a chalkline from mark to mark, and then cut the shingles along the line. Use a knife with a hook blade, starting at the top of the valley.

Installing a woven valley Woven valleys are formed by crisscrossing the shingles from both sections of the roof over the valley. Both sides of the roof must be installed at the same time. When weaving the valleys, follow these general rules:

● **WOVEN VALLEY**

1 Use a full shingle in the valley, and press each shingle snugly into the valley before nailing it.

2 Extend the top of the shingle at least 6 in. past the centerline of the valley.

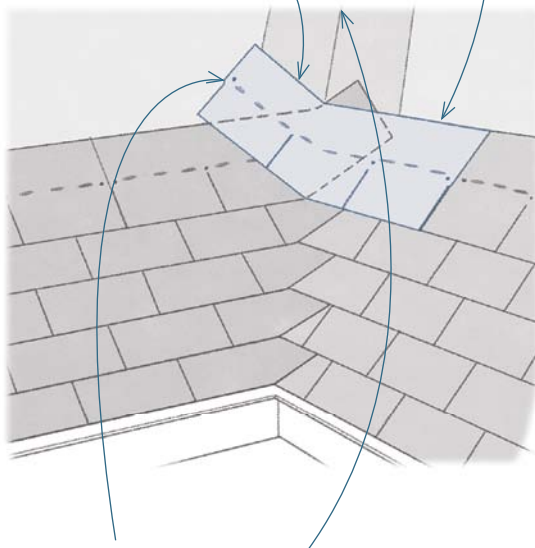

3 Keep nails 6 in. from the centerline of the valley. Also, note where the grooves will be in the course above, and keep nails away from them.

4 Overlap the shingles as close to the centerline of the valley as possible.

5 Snap a chalkline 2 in. up from the centerline, and cut along this line.

Installing a closed-cut valley In this approach, one entire side is run through the valley first, then the second roof is run over the first side. When installing a closed-cut valley, follow these general rules:

● **CLOSED-CUT VALLEY**

1 Install shingles on the lower-pitched or smaller of the two roof sections first.

2 Use full shingles on both sides of the valley, installing a one-tab or a two-tab shingle prior to the valley if necessary.

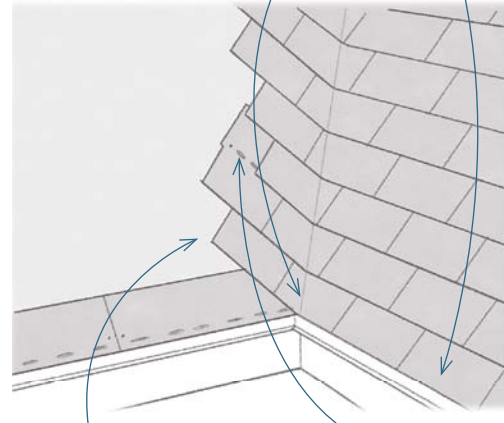

3 On the first layer, make sure the tops of the shingles extend at least 6 in. past the centerline, and press each shingle snugly against the framed valley before nailing it.

4 Keep the nails 6 in. away from the centerline of the valleys, as well as away from the groove in the course above.

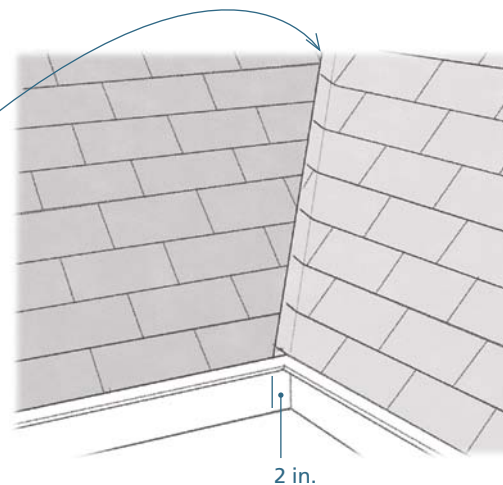

When Roofs Have Different Pitches

When intersecting roofs are not of the same pitch, there will be more courses on the side with the lower pitch. If you simply alternate sides as you weave the valley, the crossing point will quickly move out of the valley, increasing the odds of a leak and creating a sloppy appearance.

Avoid this problem by keeping an eye on the top edges of the shingles. When the tops cross on one side, install a shingle on the other side. When the tops don't cross on the side you're working on, install another shingle on that side. Follow this rule all the way up the roof to keep the weave near the centerline of the valley.

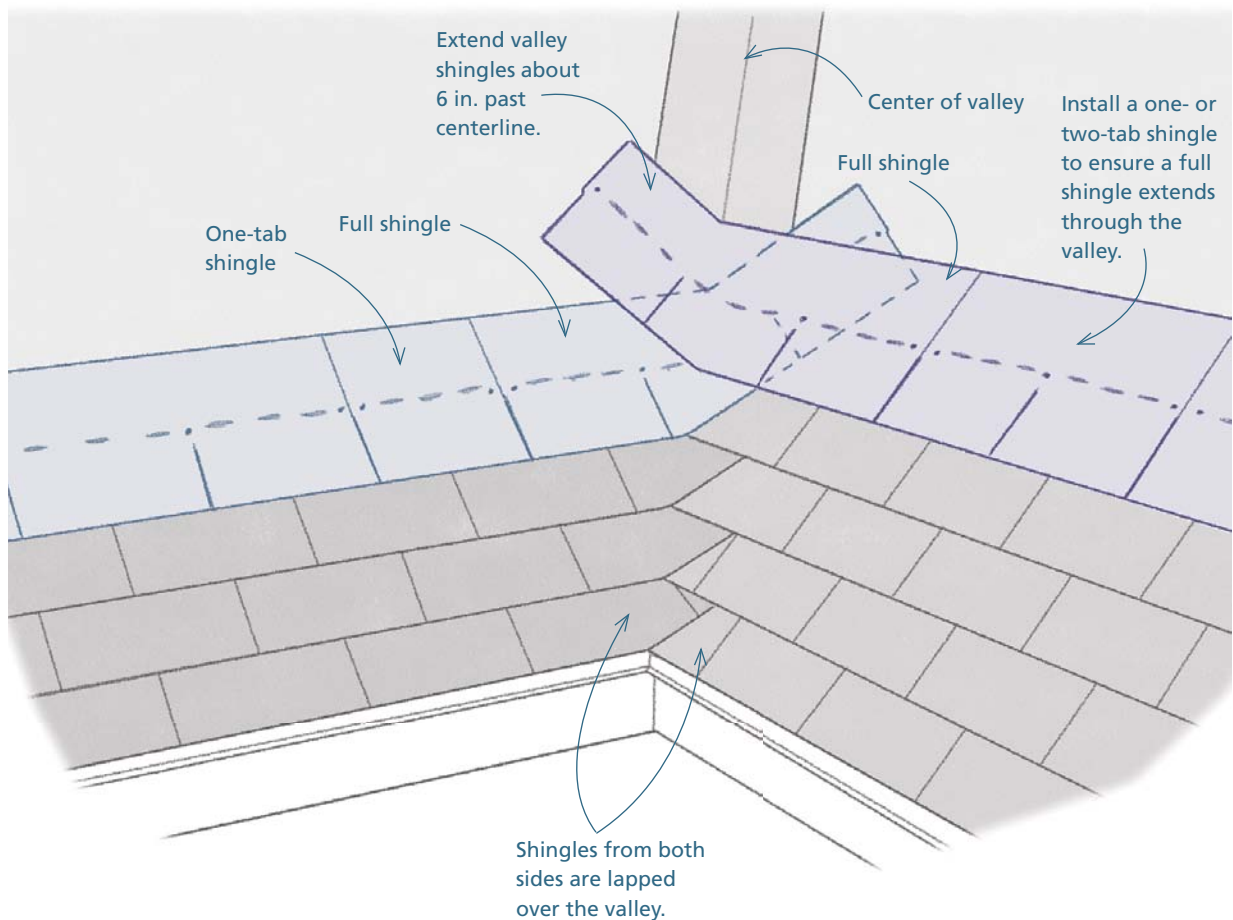

Shingling around Obstacles

When you run into an obstacle such as a dormer, an intersecting section of the roof, or some other architectural feature, you have to stop shingling and execute a layout to maintain the offset pattern on the other side of the obstacle.

The roof in the examples shown here is covered with 36-in., three-tab shingles, installed with standard 6-in. offsets in a racking pattern. If you use other shingles or other offsets, the details of the

● SHINGLING AROUND A DOGHOUSE DORMER

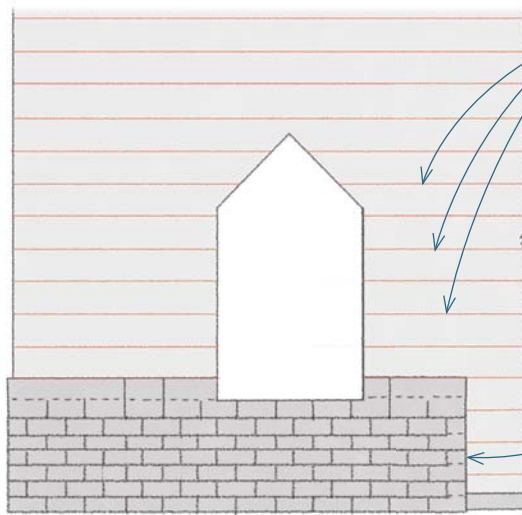

1 Lay out and strike the horizontal lines on the far side of the obstacle if not already done.

2 Run the shingles below the dormer beyond the far side, and stop as soon as the dormer is cleared.

3 Run the shingles up the near side of the dormer. Flash the wall and install the valleys.

4 On one of the marked lines above the ridge of the dormer, run a horizontal course, making sure the bottom of the course clears the intersecting ridge. Nail in the top 2 in. of the shingle.

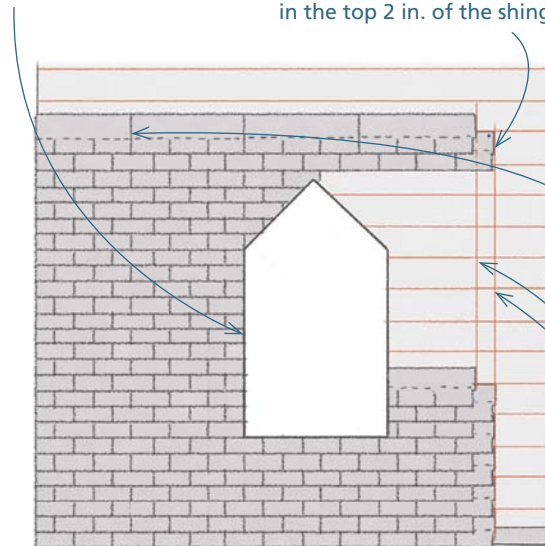

5 Install shingles above the course you've just nailed. You can run these to the ridge, but it's not essential.

6 Strike two bond lines between the top and bottom sections to guide shingles on the far side of the dormer.

process will vary, but the basic process is the same. A racking pattern simplifies the process with three-tab shingles, but this system also works with a horizontal or stair-step pattern.

Shingling around a doghouse dormer When you shingle around an obstacle that begins above the bottom of the roof and ends before the ridge of the roof, keeping the grooves arrow-straight on the far side of the obstacle is often an important aesthetic goal. This technique can be applied to a chimney, a skylight, a large vent, or any other obstacle.

Shingling around an intersecting roof When an adjoining roof intersects the section you're working on, you can't run the bottom past the obstruction. You'll have to measure and mark the bottoms of the bond lines on the far side of the obstruction. Then, when you begin shingling at the bottom of the section on the other side of the obstacle, you have to start on the correct bond line. If you start on the wrong bond line, you end up with two grooves in a row. This is both an eyesore and a source of a leak.

● SHINGLING AROUND AN INTERSECTING ROOF

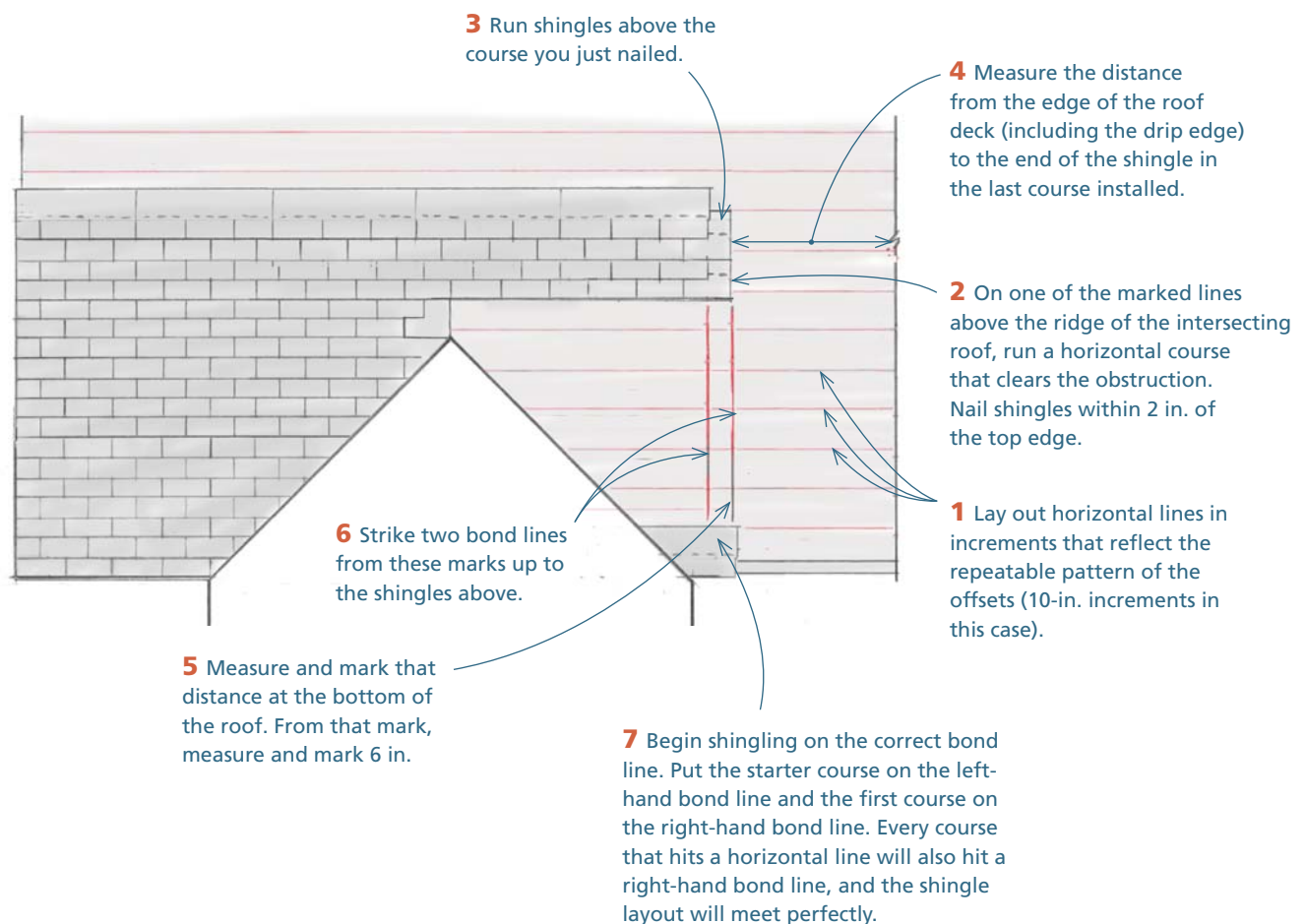

● SHINGLING AROUND AN INTERSECTING ROOF WITHOUT A BOTTOM COURSE

1 Beginning at the first line that goes over the ridge of the intersecting roof, mark horizontal lines in the section beyond the obstruction. These lines are in 10-in. increments.

2 On one of the marked lines that clears the ridge, run a horizontal course all the way to the rake. The bottom of the course should be above the ridge of the intersecting roof. Nail this course high (in the top 2 in.).

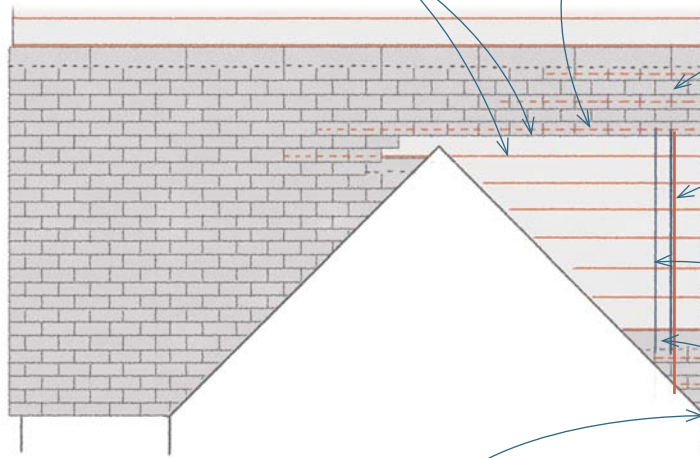

3 Install the shingles above the course you nailed high.

4 Measure the distance from the edge of the roof to the center of the first groove in the course that you nailed high. If this distance is less than 5 in., you'll have to move the layout over 12 in. to the second groove.

5 Measure and mark 6 in. from the first mark.

6 Strike two bond lines, as shown.

7 Begin shingling at the bottom corner of the triangle. Make sure that the first shingle that hits a horizontal line is on the same bond line as the first shingle above, in the course that you nailed high.

Shingling around an intersecting roof without a bottom course Sometimes there's no bottom course on the far side of an intersecting roof. To get the triangular section of the roof on the other side of the obstacle properly bonded, follow the steps above.

Flashing Masonry Walls

On most masonry walls, the face of the masonry is left uncovered and becomes the finished surface. Thus, when a roof intersects a brick or stone wall, there is no siding to direct the water to the outside of the flashing. In these situations, another layer of flashing is required. This flashing, called counterflashing, channels the water streaming down the face of a masonry wall to the outside of step flashing and, sometimes, to the outside face of apron flashing and the back piece of chimney flashing.

Installing counterflashing along a brick wall Counterflashing is a simple sheet-metal barrier, affixed to the wall and lapped over the vertical leg of the roof/wall flashing. The metal must be attached

in a manner that is watertight along the top edge. The installation also should be pleasing to the eye because it's often highly visible.

The traditional way of attaching the counterflashing is to embed it in the mortar as the masonry wall is built. This requires careful layout and cooperation between the mason and the roofer.

Counterflashing also can be mechanically fastened to the brick, with a sealant waterproofing the top edge. Because the sealant often cracks over time, this approach is prone to failure in the long term and often looks sloppy.

The third approach is a compromise between the first two. A groove is cut in the finished masonry and then the top of the step flashing is bent and set in the groove. This is easier and less expensive than the first approach and far better than the second. Follow these steps:

STEP 1 Bend the counterflashing

Although you can bend the flashing on site, it's preferable to have it done in a sheet metal shop where greater precision and crisper bends are possible.

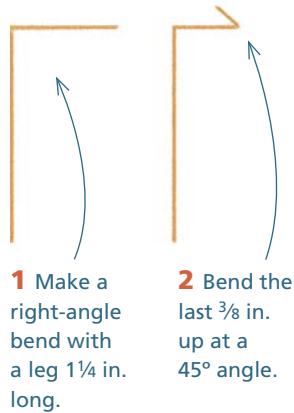

STEP 2 Cut the bottom of the flashing to fit the roof line.

Measure the distance between the brick course where the flashing will be installed to the roof and subtract $\frac{1}{2}$ in.

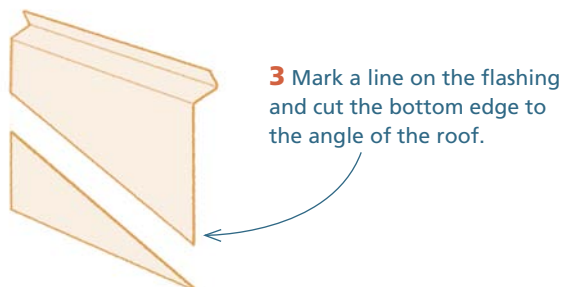

STEP 3 Attach the flashing

Insert the top edge in the groove and push the flashing flush with the wall. If you need to tap in place with a hammer, use a scrap of wood to protect the flashing.

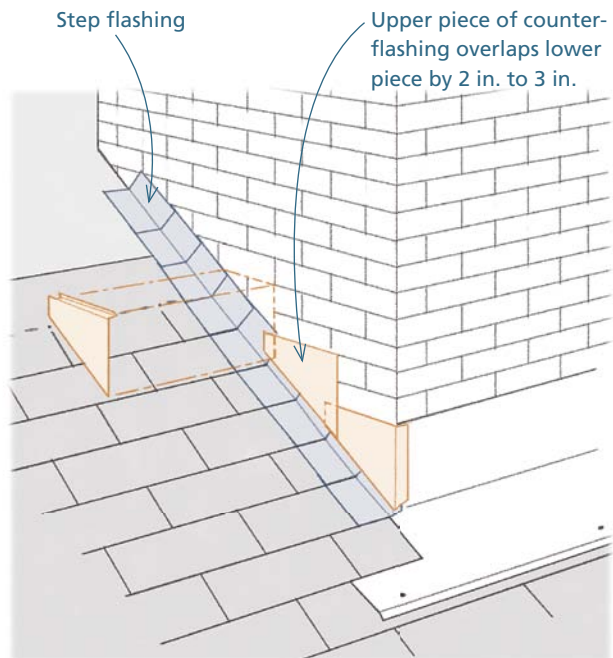

STEP 4 Fasten the flashing

Use Tapcon® concrete screws, screws with anchors, masonry nails, or lead wedges. Make sure the fasteners are galvanically compatible with the metal you're using for the flashing.

STEP 5 Seal with caulk or mortar.

To keep the brick above the flashing clean, use painter's tape above the groove.

• OPTIONS FOR ATTACHING FLASHING

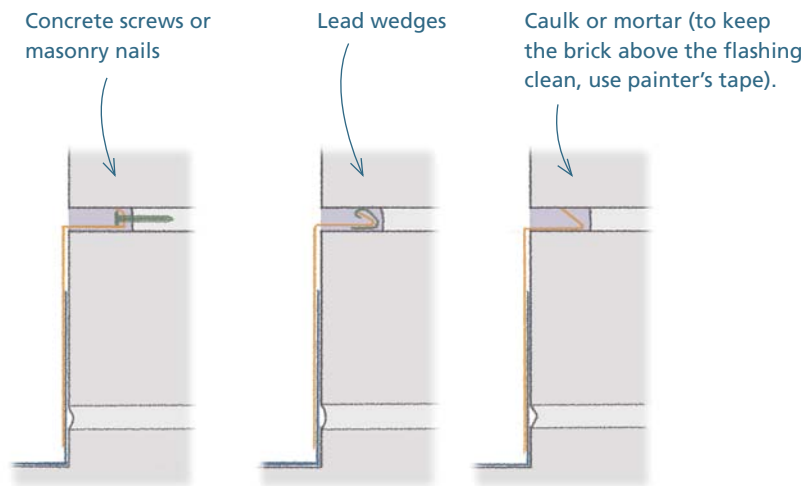

Building a Cricket and Flashing a Masonry Chimney

The flashing for a chimney varies, depending on the location of the chimney in the roof. This section discusses the flashing of a chimney in the field of a roof with the back facing uphill. The techniques can be adapted with minor modification to flashing a chimney in any part of the roof.

When the chimney is in the field of a roof, a back piece of flashing is sometimes used. (For more on the back piece of flashing, see "Flashing Masonry Walls" on p. 220.) In this section, the other option, building a water-diverting cricket, is presented.

TOP TIP

Making Lead Anchors

.....
To make lead wedges, cut 1-in. by 2-in. strips of soft lead flashing. Before you set the flashing in the groove, wrap the strip around the bent portion at the top. After tapping the flashing into the groove, use a punch to pack the lead in the joint.
.....

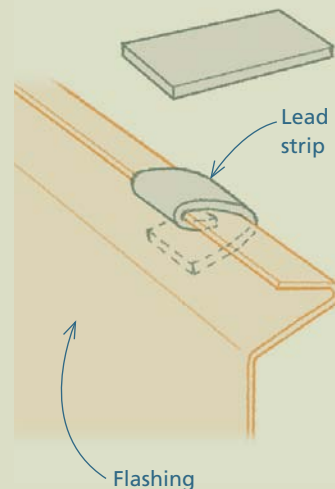

STEP 1 Frame the cricket

Frame a small gable roof the width of the chimney on top of the main roof.

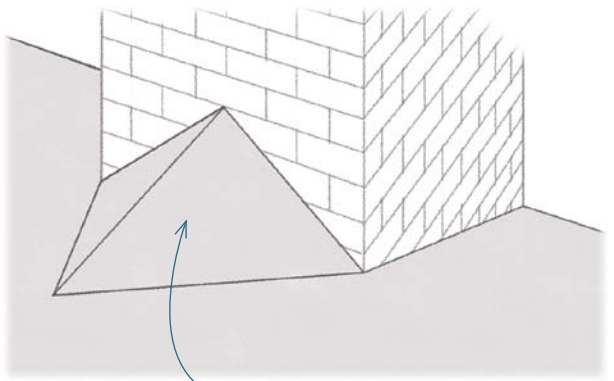

Frame cricket using the techniques discussed on pp. 138–140.

STEP 2 Install peel-and-stick membrane

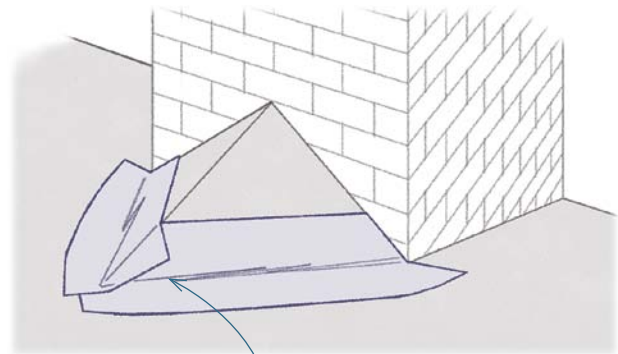

Cut and fit the membrane in the valleys.

STEP 3 Install the front piece of flashing

The front piece is essentially a large piece of apron flashing. Trim the corners, as shown, and insert the top edge in the groove.

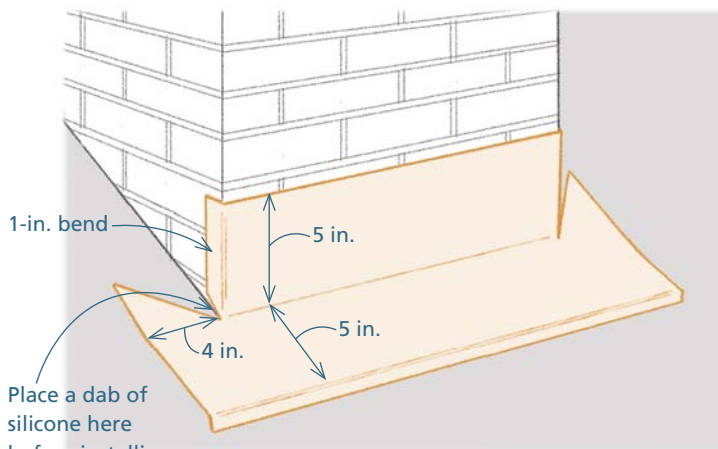

Place a dab of silicone here before installing the first piece of step flashing.

STEP 4 Step-flash the sides of the chimney

Wrap the corners carefully to prevent leaks.

STEP 5 Begin shingling up both sides of the cricket

Step-flash the back of the chimney and, at the same time, install the valley system. Woven or closed-cut valleys are best.

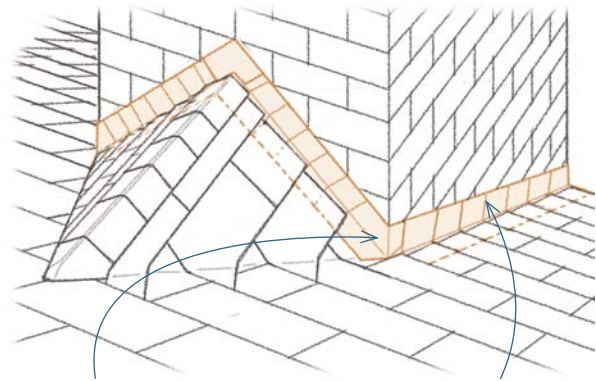

2 Carefully wrap the corner and continue up the cricket.

1 Install step flashing in the same manner as you would for a wood-frame wall.

WAYS OF WORKING

Flashing a Stone Chimney

The intersection between a stone chimney and a roof is difficult to flash and is often a source of leaks. Because the stone surface is so irregular, it's hard to fit the step flashing tight to the wall. An even more challenging task is getting a waterproof seal along the top of the step flashing.

The best way to flash a stone chimney that's already built is to use sheet lead. This soft and malleable material, which can be formed to the irregular shapes of the stones, offers the best possibility of getting a reasonably tight fit to the uneven wall.

When building new, have the mason use brick below the roofline—either in the attic or within the thickness of the roof frame. As the mason brings the chimney through the roof, have him lay the bricks to the layout of the flashing. Here's how:

STEP 1 Mark the front of the second step

Lay two full courses of bricks above the roofline, and mark the front of the second step by laying a 2x4 on edge and marking where it crosses the top of the last course of bricks laid.

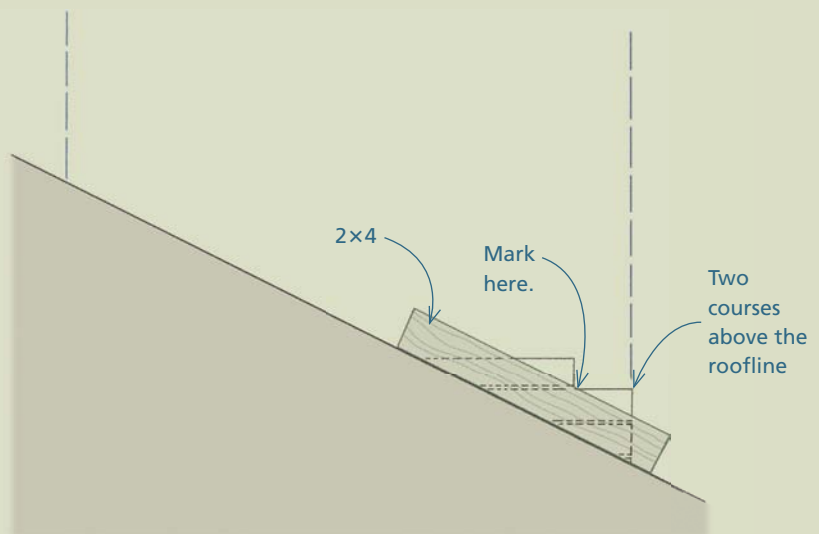

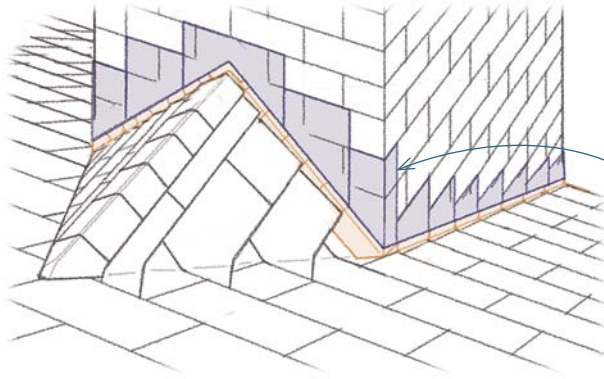

STEP 6 Install the counterflashing

Wrap the corners by about 1¾ in., as shown.

Use hand seamers to bend this piece around the corner.

STEP 2 At the mark, begin the second step

Steps one brick tall are good for roofs up to 8-in-12 in pitch. Above that, make each step two bricks tall.

STEP 3 Repeat steps 1 and 2 to create the third and succeeding steps

STEP 4 Build the chimney out of stone

After forming these steps out of brick, the mason can build the wall or chimney out of stone above the brick

Have him rake out the horizontal joint between the brick and the stone before the mortar sets up. This will obviate the need to cut a groove later.

STEP 5 Complete the top with stone, and hide the seam with counterflashing

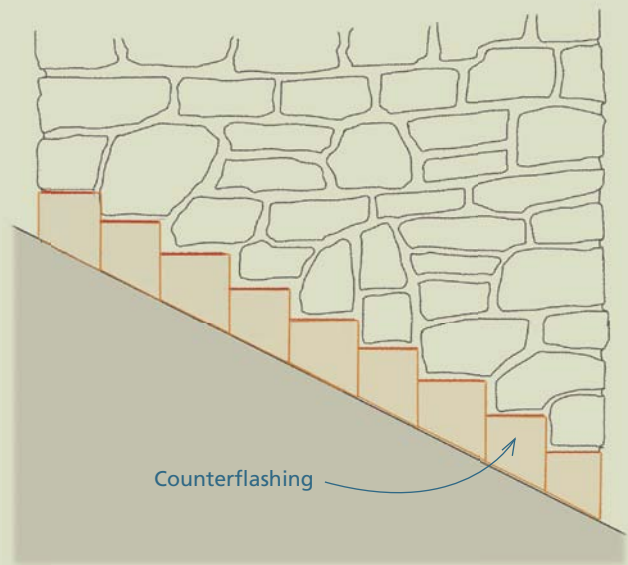
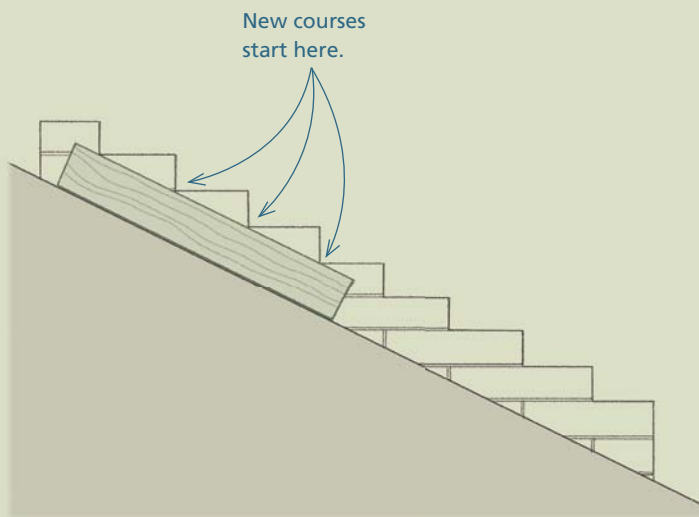

Finishing the Roof

After installing shingles and flashing, there are a few steps left to finish the roof: capping the ridge and hips (on hip roofs); caulking key points in the roof; and, on some roofs, installing vents.

Installing Ridge and Hip Caps

On roofs that don't have a ridge-vent system, the caps are installed directly over the shingles. Here, I'll describe a method for cutting and installing caps made from three-tab shingles. The same basic procedure can be followed to install the custom caps that are sometimes used with architectural shingles.

• RUNNING CAPS ON A SIMPLE GABLE ROOF

STEP 1 Cut the caps

1 Using a 12-in. Speed Square as a guide, cut from the center of the groove to the top of the shingle.

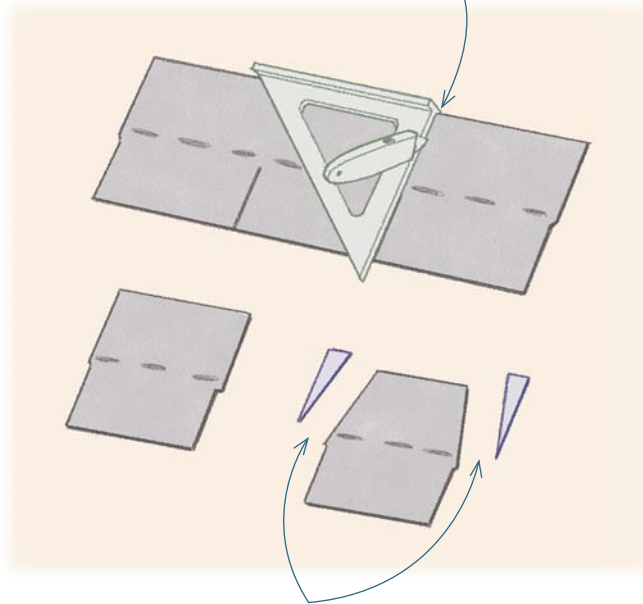

2 Double-cut the caps for ridges that are clearly visible from a window.

STEP 2 Strike a line

1 On both ends of the roof, center a cap over the ridge by eye.

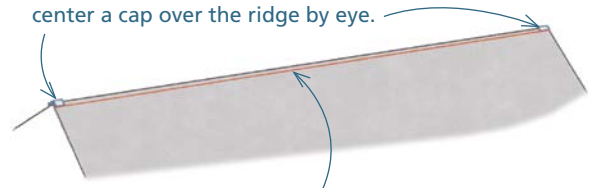

2 Snap a chalkline connecting the bottom edge of one shingle with the bottom edge of the other.

STEP 3 Nail down the caps

1 Set the first cap with the edge on the line, fold it over the ridge, and nail the cap on both sides.

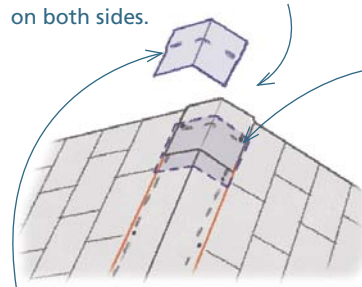

2 Place nails about 1 in. from the edge and just below the sealing strip.

3 Set the second cap over the top 7 in. of the first, leaving 5 in. of the first shingle exposed.

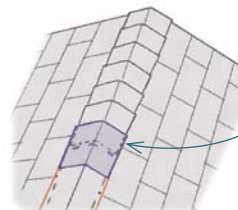

4 Repeat this process for the length of the ridge.

STEP 4 Install the final cap

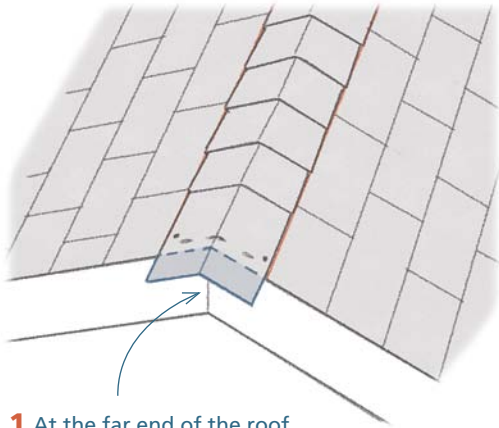

1 At the far end of the roof, trim the top of the first cap that reaches the rake as needed to fit with the 5-in. exposure.

2 Cut the lower 5 in. off a cap (the part normally exposed to view), and use that piece to cover the upper part of the last cap installed.

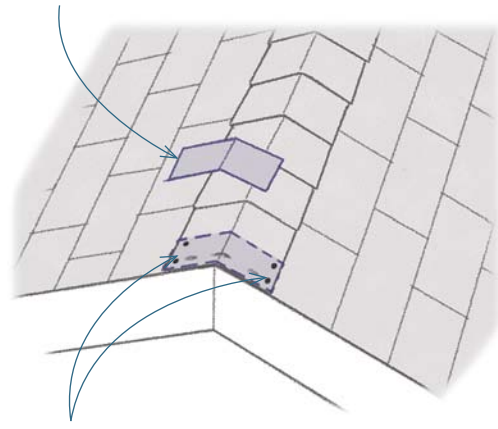

3 Use two nails on each side of this cover cap. These nail heads should be the only ones exposed to the weather in the entire ridge. Coat them with sealant.

Installing hip caps Hip caps are usually visible from the ground and often visually prominent. Although the installation of hip caps is similar to that of ridge caps, there are a few important differences, as shown below.

STEP 1 Trim the first cap to match the eaves

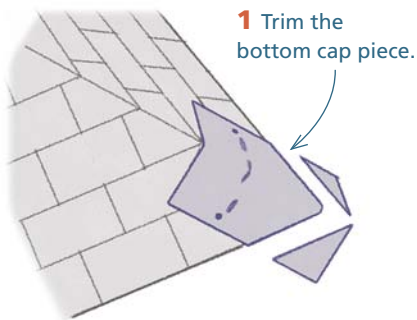

STEP 2 Double-cut the remaining caps with tapers on each upper edge for a clean appearance

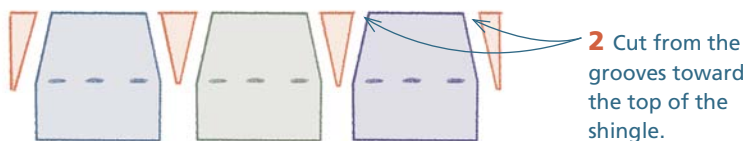

STEP 3 Fold each cap over the hip

3 Use one nail per side, placing the nails just below the seal-down side (above the exposure line).

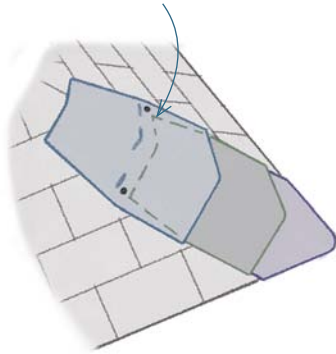

STEP 4 Trim the top



As you reach the top of the hip, cut the portion of the cap that runs over the top. Make this cut from the center of the top edge of the cap down to the point where the hip reaches the ridge. Fold the exposed part over the end roof and trim the edges that will extend below the ridge cap.

Capping an intersecting ridge The ridge-cap shingles on a dormer or intersecting roof are installed just like any other ridge caps—until you get to the main roof. At that point, the caps have to cross the tops of the valleys and run neatly under shingles on the main roof.

When running shingles on the main roof across the intersecting roof, always leave space below the first horizontal row of shingles to allow the ridge caps to be installed. Nail this course high so that you'll be able to slip the shingles and caps into place as you finish both the valleys and ridge. To install these caps and finish the main roof, use the following procedure:

STEP 1 Install shingles



1 Run shingles on both sides of the intersecting roof and on the main roof above the intersecting roof, making sure to leave room for the cap pieces on the intersecting ridge.

STEP 2 Cap the ridge

3 When the cap reaches the main roof, cut down the center of the cap, fold the pieces up the main roof, and nail them. You may have to cut and install two caps in this manner.

2 Cap the ridge of the intersecting roof in the normal way, starting at the outside end.

STEP 3 Install the final cap and finish the shingles on the main roof

Cut the center of the final cap from the bottom up, and install over the seam of the second-to-last cap.

2 The shingles on the main roof should run over the cut portion of the caps. Where necessary, install exposed nails at the ridge/main roof intersection to make the shingles lie flat. Seal any exposed nails and the intersection of the ridge and the main with caulk or roofing cement.



1 Notch the tab to fit snugly over the ridge.

STEP 4 Finish the shingles on the main roof

Installing Ridge Vents

Building scientists disagree over the necessity of roof ventilation (see chapter 7), but when ventilation is used, most experts agree that the ventilating air should move in a sheet from the eave to the top of a section of the roof (either the ridge or where the section of a roof terminates at a wall). This involves the use of strip vents along the eaves and continuous vents along the ridge or wall. This section discusses the installation of ridge vents. The installation of eave vents will be discussed in chapter 6.

● RIDGE VENTS

1 For roofs with no ridge (i.e., truss roofs), make the slot about 2 in. wide.

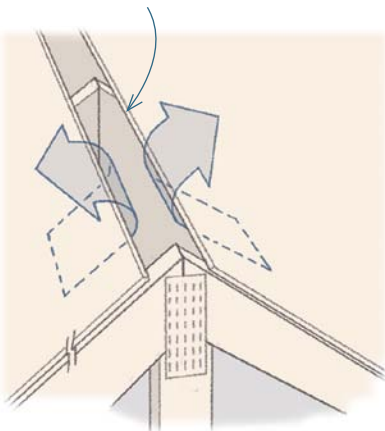

2 For roofs with a ridge, make the slot about 4 in. wide to allow air to flow around the ridge. You can use a 2-in. slot if the ridge drops below the tops of the rafters, but check with your building inspector first.

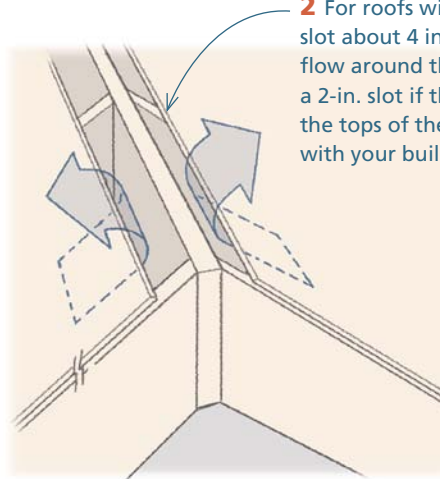

Installing ridge vents There are two main types of ridge vents: metal and nail-over. Both types are installed over a slot cut in the apex of the roof deck.

Run the shingles all the way up to the edge of the slot, and cut the final courses around the slot. Make sure the vent will extend into the exposed area of the final shingle (the lower 5 in.).

Metal ridge vents are simply centered over the slot and nailed in place. Before installing a metal ridge vent, you have to run three or four caps on each end of the ridge. The vent then overlaps about 10 in. of the caps. To waterproof the ends and the splices between pieces, use the neoprene pieces that come with the vents. Nail the vents according to the schedule specified by the manufacturer.

There are three types of nail-over vents: corrugated, rigid, and mesh. The first two come in 4-ft. sections; the mesh vents come in a roll.

● NAIL-OVER VENTS

All three types of nail-over vents are made with tough composites, and the installation for all three is essentially the same. As with metal ridge vents, nail-over vents should overlap caps at each end of the roof about 10 in. Use long roofing nails (2 in. to 2½ in.) to nail caps over the vents.

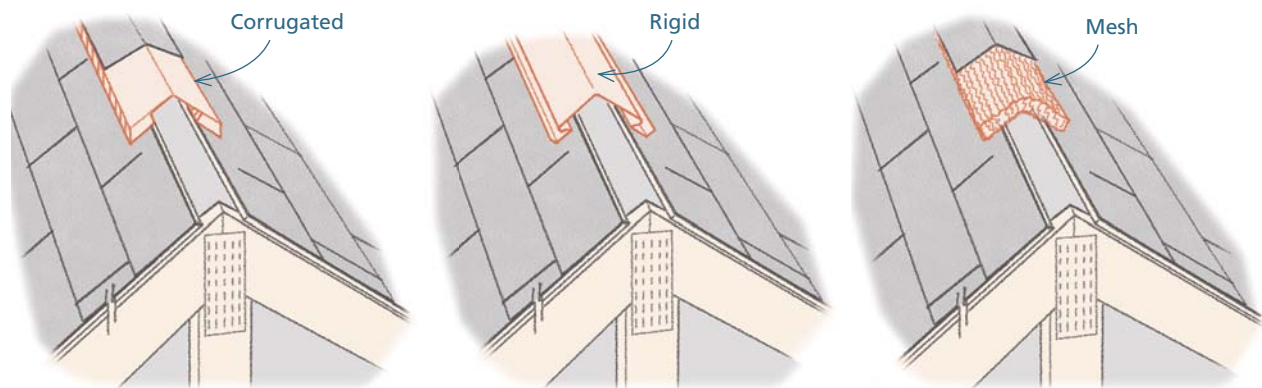

Final Inspection

Clean up any dropped nails, which can rust and stain the roof if left in place. Look for any shingles that are sticking up. If you see one, lift the tab and look for a dropped nail under the tab or a nail not driven all the way in. Go over the roof and make sure all exposed nails are covered with sealant. Finally, check the corners of flashing and fill any openings with sealant.

Installing Windows, Exterior Doors, Siding, and Trim

AS WE SAW IN CHAPTER 2, exterior walls play a major role in the structure of the house, holding up floors, walls, and ceilings and resisting the lateral forces imposed by wind and seismic events. Exterior walls serve as a barrier to the weather, keeping the interior comfortable and protecting the wood frame from the harmful effects of water. Exterior walls also have openings (doors and windows) that permit access, allow light and air into the house, and provide a view. Finally, exterior walls have an enormous impact on the way the house looks. A great deal of the creative energy that goes into the design of a house is, in fact, devoted to the choice of the materials and the way they are installed on the outside walls of the house.

Because they do so many things, modern exterior walls are multifaceted assemblies, which are built in layers. This chapter discusses the outermost layer of exterior walls, which includes the windows, doors, and siding systems.

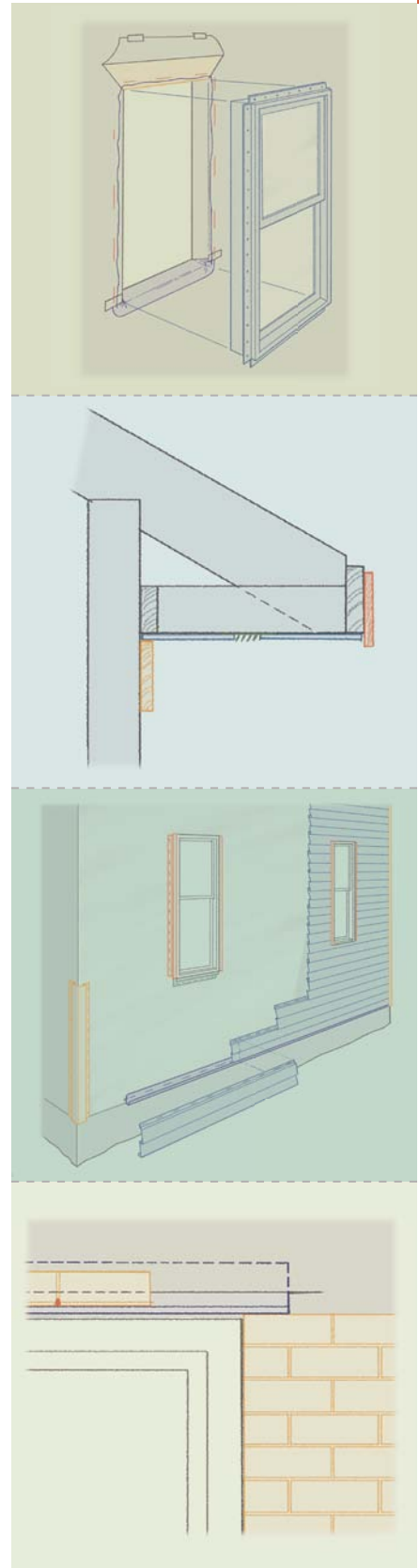

Shedding Rainwater

Although there are important differences between the way water runs down the surface of siding and the way it runs down a roof (see the drawing on the facing page), the strategies for shedding water are basically the same. Builders rely on a predictable flow of water and use a combination of overlapping materials and flashing in key points to keep the water on the outside of the wall.

The biggest challenges are posed by horizontal surfaces that interrupt the flow of water down the side of a house. These include doorsills and windowsills, the tops of doors and windows, horizontal trim details, and the ledgers of exterior decks. It's not hard to visualize why these areas are the most likely candidates for trouble. Under the right wind conditions, water flows in a sheet down the siding or the face of a door or window. When this sheet of water crashes into a sill, deck ledger, or other horizontal piece, it splashes and moves laterally, making the potential for leaks high.

● EXTERIOR WATER COLLECTORS

Horizontal elements that interrupt the flow of water are the most likely source of leaks.

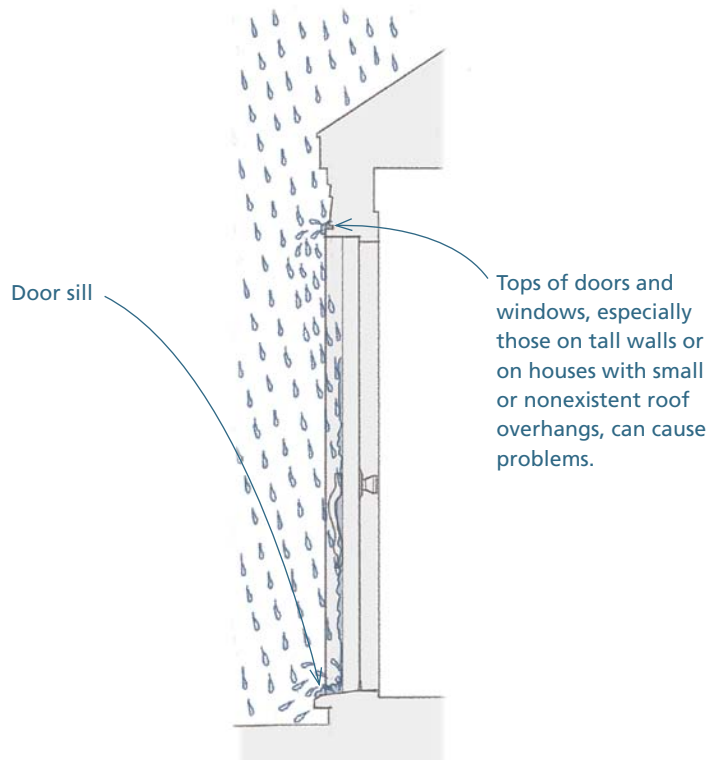

● COMPARING ROOFS AND WALLS

Like roofs, exterior walls face the weather, but there are several key differences in how these two surfaces shed water.

As water flows down the slope of a roof, gravity pulls it tight to the surface and through any defects in the roof. Because of this, a 12-in.-wide asphalt shingle requires an overlap of 7 in. And, a caulk joint is never a good way to protect the seams of a roof.

Walls are often protected by overhanging eaves, rakes, and porches. Even modestly sized eaves and rakes protect the wall from much of the rain that falls on the house, especially the upper parts of walls.

Wind also pushes water away from the wall on the lee side of the house.



When there's little wind, water falls parallel to the face of the wall, and little water reaches the siding. When wind does push rainwater against a wall, gravity pulls the water straight down, not into vertical seams.



Wind often pushes a lot of water against the wall.

WAYS OF WORKING

Limiting Vapor Transmission

In addition to rainwater, another source of moisture in exterior walls is vapor, which can come from inside or outside the house. Moisture is conveyed into and through a wall in two ways. First, vapor is carried by air that passes through openings in the wall—a process called air transport. Second, vapor moves through the material of the wall as a result of vapor pressure difference—a process called vapor diffusion.

Controlling the transmission of vapor into and through walls (and floors and ceilings) is essential to both the energy efficiency and the long-term durability of the house. It's a complex process, and, to make matters worse, systems for controlling the passage of vapor must be tailored to the climate where the house is built.

Windows, doors, and siding systems are just one part of a larger strategy for controlling the movement of vapor into and through exterior wall assemblies. A more comprehensive discussion is the subject of chapter 7.

Installing Underlayment

For about 75 years, builders have been using asphalt-impregnated building paper, usually called tar paper or roofing felt, as an underlayment for siding. It's still widely used. In the past 20 years, however, a number of synthetic housewraps have emerged as alternatives.

Building scientists classify both types as weather-resistive barriers (WRBs). They play an essential part in wood-framed exterior wall assemblies by serving as a secondary barrier to keep rainwater out of the wall and by blocking the passage of air.

This section focuses on the proper installation of both types of underlayment. The general guidelines provided here work with felt and most types of housewrap. If you're using housewrap, check the manufacturer's instructions to see if there are any special requirements for that material.

Dealing with Openings

The sequence for dealing with window and door openings varies. When using housewrap, which has far more resistance to tears and wind damage than felt, builders often run the underlayment over the openings and leave the cutting and detailing for later. Typically, they deal with the openings as they install the windows and doors. When using felt, which is more likely to rip and blow off in the wind, they often wrap and flash the opening as they install the underlayment.

• UNDERLAYMENT INSTALLATION BASICS

The guiding principle for installing underlayment is the same as it is for all roofing and siding material.

1 The top piece always laps over the lower piece.

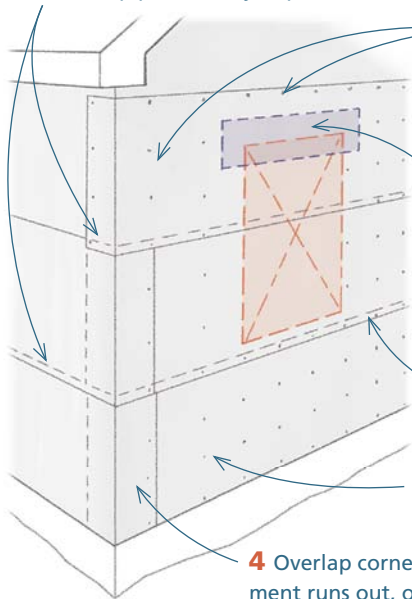

5 For felt, use roofing nails or cap nails (nails with large plastic washers) to attach the underlayment. For housewrap, use the fasteners recommended by the manufacturer, usually wide-crown staples or cap nails. Fastening schedules are often specified by manufacturers and/or building codes.

6 Don't install fasteners in the first 12 in. above the tops of window and door openings, and extend this no-nail zone 12 in. past both sides of the opening. The underlayment in these areas will need to be folded up when you install the windows or doors.

3 Lap each succeeding row at least 2 in. over the row just below.

2 Install the pieces horizontally, starting at the bottom of the framed wall.

4 Overlap corners by at least 12 in. Where one roll of underlayment runs out, overlap the end by at least 12 in. (check the manufacturer's recommendations).

• DEALING WITH OPENINGS

In the example shown here, the underlayment is housewrap, but use the same approach when using felt. The underlying principle is to interweave the underlayment, the flashing, and the window or door unit so that the water always flows over the piece below.

STEP 1 Cut an inverted Y pattern in the underlayment

The bottom of the Y pattern should end at the two sides of the opening, 2 in. above the bottom.

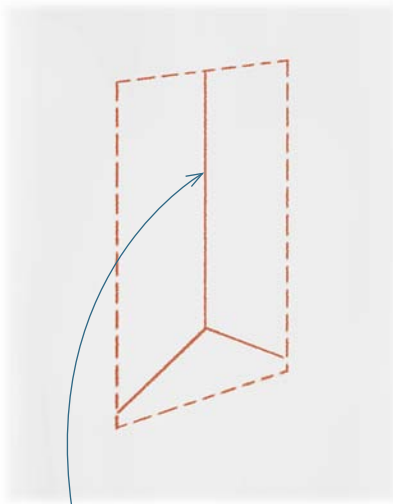

1 Cut an inverted Y.

- 3 Cut flush with the frame. 4 Cut up and out from the corner.

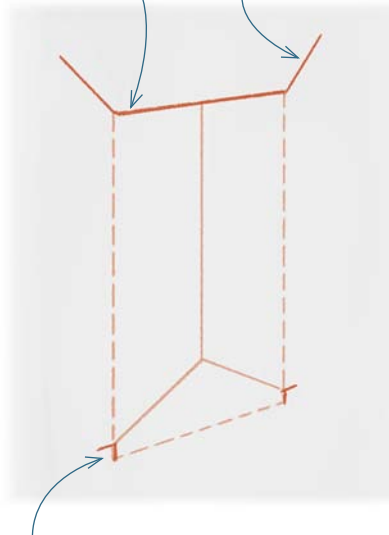

2 Cut 2 in. up along the side of the framed opening.

STEP 2 Cut the bottom 2 in. even with the sides

STEP 3 Cut along the top of the opening

STEP 4 Cut away the top corners at roughly a 45° angle for about 10 in. above the opening

STEP 5 Fold the bottom into the opening and over the inside wall

7 Leave the top flap loose.

5 Fold this flap in.

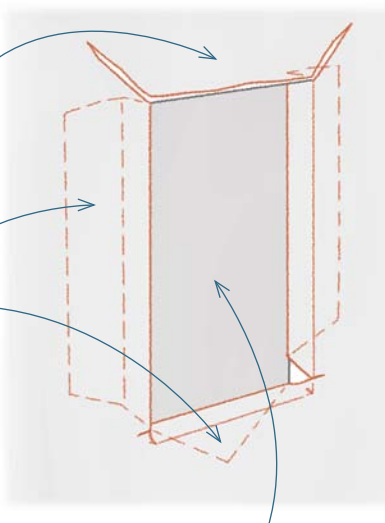

6 Fold the sides in and attach minimally.

STEP 6 Temporarily fasten the side flaps to the inside of the wall

You will have to loosen them briefly when you install the sill flashing for the door or window.

STEP 7 Leave the top loose for now; it will lap over the head flashing of the door or window

Drainable Housewraps

Even when installed properly, windows, doors, and siding are rarely perfect weather barriers. Fierce storms and power-washing equipment occasionally force water past this primary barrier. The sun, the settlement of the house, and the shrinking and swelling of materials all take a toll on key points in the barrier, leaving openings for water to enter.

The WRB, whether it's made of felt or housewrap, serves as a secondary barrier to help keep the water out. But what becomes of this water after it hits the WRB? Water often becomes trapped between the back of the siding and the WRB. From there, most of the water slowly seeps down and weeps out on top of flashing or exits through the bottom of the cladding. Some of the moisture stays behind the siding until it evaporates.

This is far from ideal—especially in locations where the siding is subject to large amounts of wind-driven rain. To drain this water more rapidly and more completely, many builders have begun using drainable housewraps or rain-screens. These allow the water to run, rather than seep, out of the assembly.

Building scientists recommend these systems be used in areas that receive more than 50 in. of rain per year. Because they are the best way to drain and dry wall assemblies, they're a good choice anywhere heavy rain and wind is expected.

These housewraps, which are sold under trade names such as DrainWrap™, WeatherTrek®, and RainDrop®, use crinkles, dimples, or corrugations on the surface to create spaces through which the water runs down and out of the exterior shell. These housewraps also speed up the drying of walls that get wet behind the siding. They are installed in the same basic manner as smooth housewraps.

When using drainable housewraps, it's essential to get the flashing details right. The water that runs down behind the siding must run over the flashing and out of the assembly.

● DRAINING WATER THAT GETS PAST THE SIDING

Drainable housewrap has a textured surface that permits water to drain behind the siding.

Conventional housewrap and building felt can trap water behind the siding.

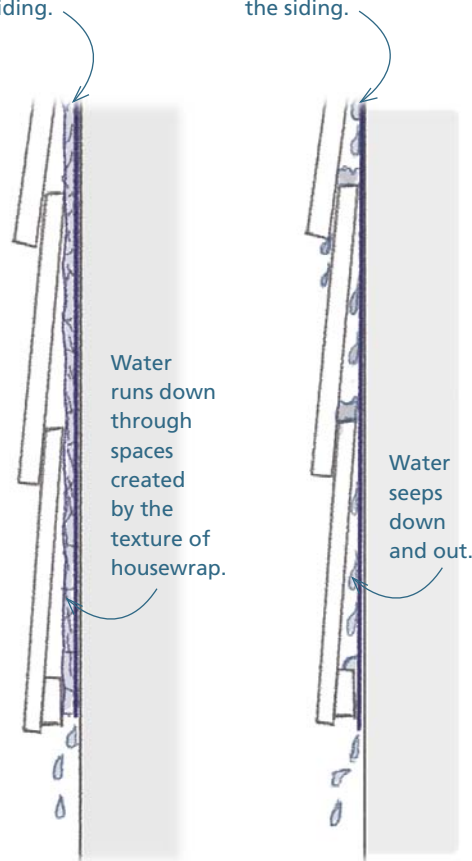

Rainscreens A rainscreen is a $\frac{3}{8}$ -in. to $\frac{3}{4}$ -in. airspace built between the WRB and the back of the siding. Most of the water that gets past the siding doesn't make it to the WRB; instead, it runs down the inside face of the siding. Rainscreens not only drain water quickly but also dry out quickly.

The space behind the siding has two other important advantages. It equalizes the air pressure on the inside and outside of the siding, and it serves as a capillary break inside the wall assembly. By equalizing the air pressure, the space neutralizes one of the main forces that draws moisture into the wall: air pressure differential. By providing a capillary break, the space stops the wall assembly from soaking up the water that makes it past the siding. (There will be more on pressure equalization and capillary action in chapter 7.)

There are, however, some tradeoffs. A rainscreen is an additional expense, and it requires a crew that understands how it works. It also complicates construction.

● BUILDING A TRADITIONAL RAINSCREEN

1 After installing the WRB and flashing, align furring strips ($\frac{3}{8}$ in. minimum but often $\frac{3}{4}$ in. by $1\frac{1}{2}$ in.) over the studs, and nail them to the wall. Visualize how doors, windows, and trim will be attached, and make sure furring strips are strategically placed to support them.

3 At the bottom and top of the wall, screen cavities to keep out insects, using window screen or a product such as Cor-A-Vent® SV3.

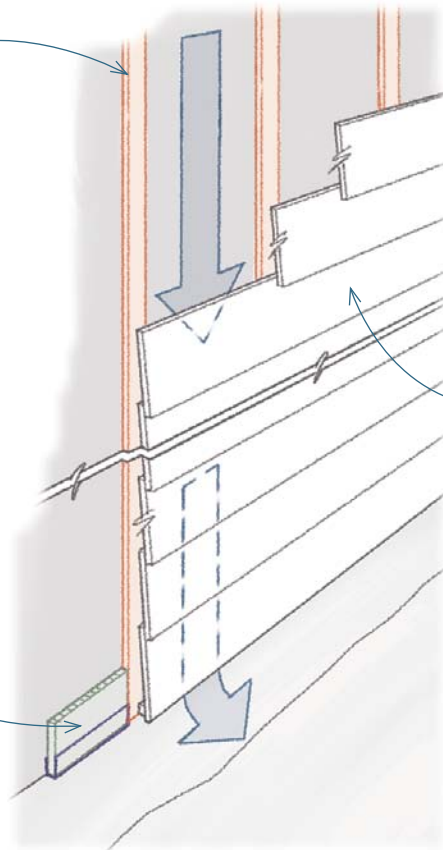

2 Nail the siding to the furring strips.

TOP TIP

Ask about Fire Blocking

.....
 Building codes generally require fire blocking at the tops and bottoms of all wall cavities. Doing this in the cavities of the rainscreen would block drainage and prevent drying, defeating its purpose. Many building officials make an exception for rainscreens, but others do not. If you want to build a rainscreen, make sure that your compliance officer will accept it.

● MANUFACTURED RAINSCREENS

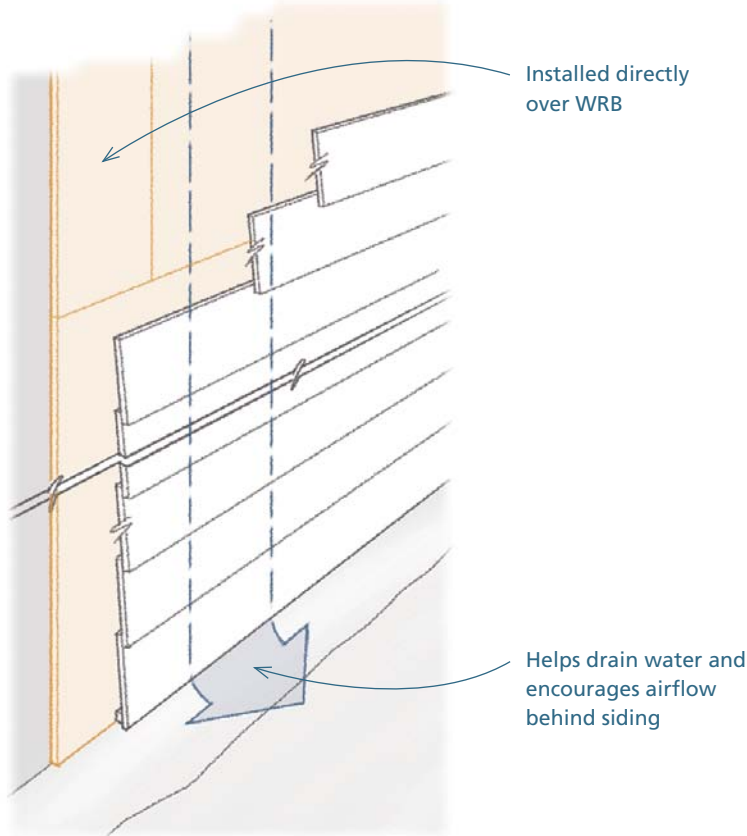

Installing manufactured rainscreen materials In recent years, manufacturers have created meshlike plastic materials that hold siding materials out from the face of the WRB, serving much the same purpose as a conventional rainscreen. These materials, sold under trade names such as Home Slicker® and WaterWay, consist of grids that are molded with ridges to create a space behind the siding. They have enough body to resist compression when siding and trim are nailed over them. They usually come in 1-m (39.37-in.) rolls.

Install the WRB and the doors, windows, and flashing in the standard manner. In some cases, it's necessary to fur out trim and window and door casing to make up for the extra depth of the rainscreen. Attach the rainscreen material using the fasteners specified by the manufacturer. Don't stretch the material as you install it. And don't overlap the pieces; butt the edges on the ends and at the bottom and top of each horizontal course. Benjamin Obdyke, the manufacturer of Home Slicker, also offers rainscreen products that come attached to either felt or smooth housewrap.

Installing Windows and Exterior Doors

The installation of a window or door is a three-part process: flashing the bottom of the opening; installing the unit; and flashing the sides and the top of the window or door.

Flashing the Bottom of the Opening

● POTENTIAL FOR LEAKS

Rain blown against a window flows down the surface and strikes the sill, making this a high-risk area for rot.

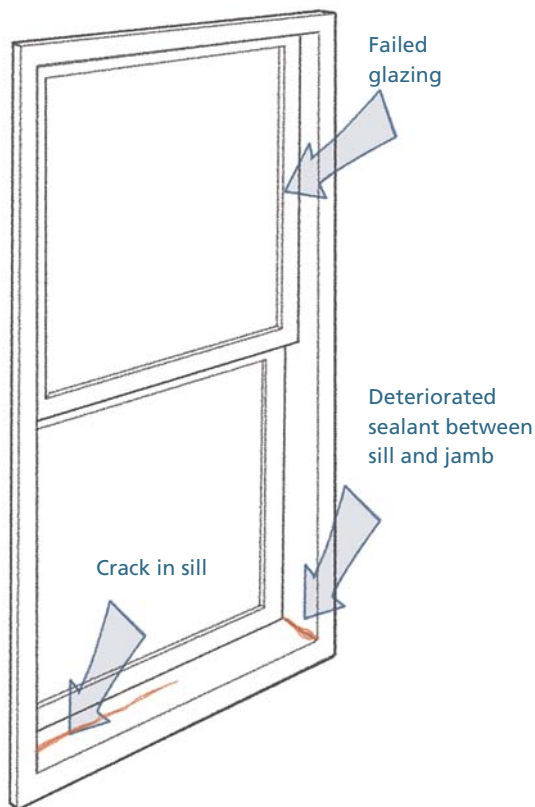

● FLASHING THE BOTTOM OF A WINDOW OPENING

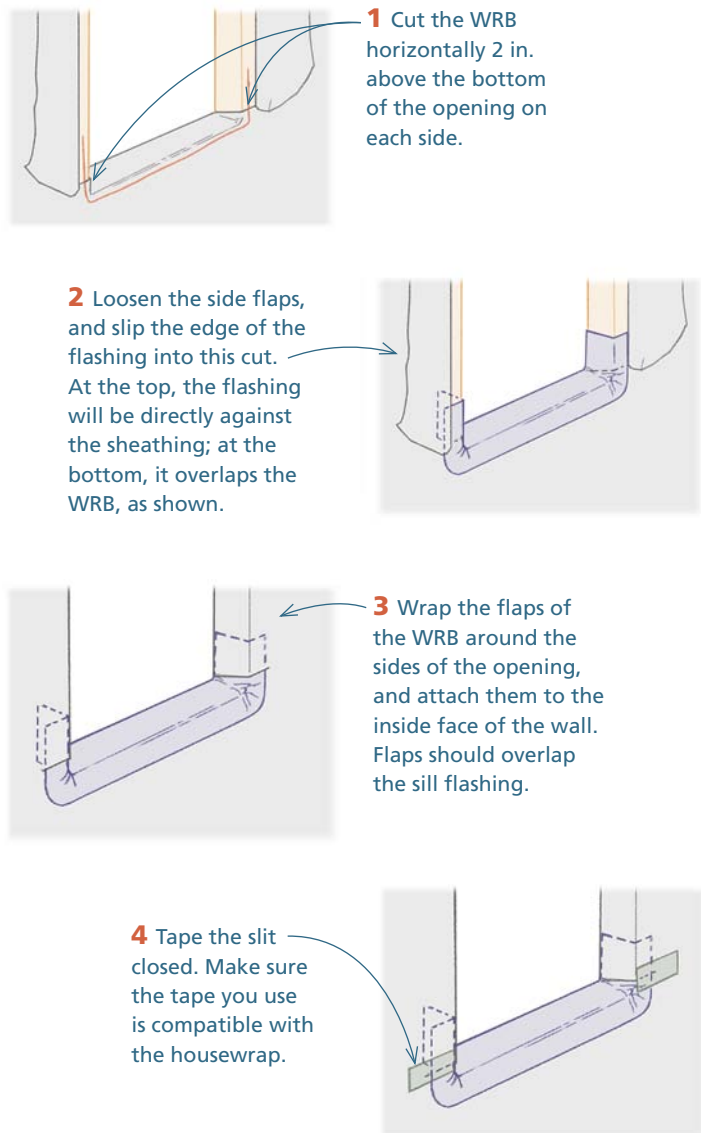

Materials for Flashing Sills

There are three basic options for sill flashing material: straight pieces of peel-and-stick flashing; flexible/conformable peel-and-stick flashing; and sill pan flashing.

Option 1: Straight peel-and-stick sill flashing

Straight pieces of peel-and-stick flashing can be installed by cutting the corners as shown. This kind of flashing has an important shortcoming: The corners must be cut and folded on site. When you do this, you end up with seams in the most vulnerable points in the flashing—the corners—and you must rely on sealant to waterproof these seams. To avoid the necessity for this sealant, some manufacturers offer preformed corners (SureCorner™), which can be used in conjunction with straight pieces of peel-and-stick flashing.

Option 2: Flexible/conformable flashing

Another option is to use a peel-and-stick product (FlexWrap) that stretches around corners without needing to be cut. This seamless option is easy to install and better than relying on sealant.

Option 3: Sill pans

A third option is to use a sill pan. Molded PVC sill pans can be cut and fit to any size door or window opening. There are several types of these pans, which go by such trade names as Weathermate™ Sill Pan, Jamsill Guard®, and SureSill. All of these have molded corners, which eliminate the need for sealant in the corners. A middle section is cut to fit the size of the opening and then glued with PVC cement to the corner pieces. The best designs have ribs and are sloped toward the outside of the opening. Both of these measures help move the water quickly to the outside of the wall.

All of these products are fairly new and have not yet passed the test of time. So far, however, it appears that sill pans are the best option for flashing sills. Check the manufacturer's instructions before installing any of these products.

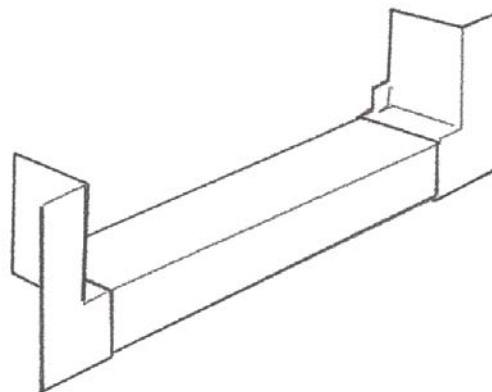
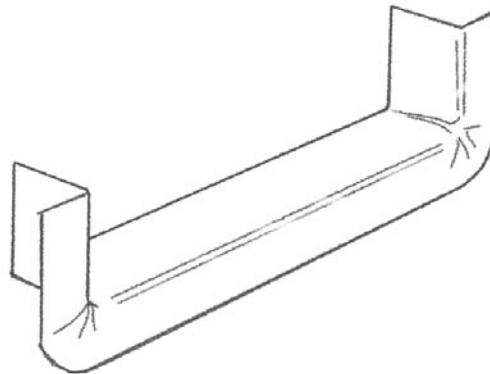
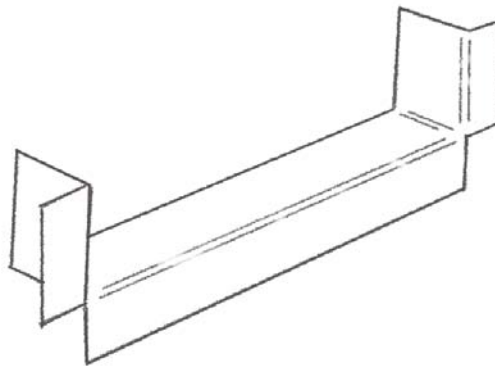

WAYS OF WORKING

Installation Basics

When you fasten exterior windows and doors to the wall, you have to do three things. First, attach them precisely and securely. As part of the outer shell of the exterior walls, windows and doors are often exposed to strong wind loads. However, the primary loads come from humans. Windows and doors are operable assemblies, and the occupants of the house open and close

them often. To keep these mechanical devices operating smoothly for decades, they have to be firmly and solidly attached to the frame.

Second, prevent leaks around the perimeter. To avoid leaks, integrate the WRB and the window and door flashings with the units as you install them.

Third, install windows and doors plumb and square and, usually, at the same height. In some cases, the spaces between windows also need to be uniform in size. Avoid denting or chipping the surface of the units.

Setting Window and Door Units

STEP 1

Prepare the opening

1 Lift the top flap and tape it to the wall above the opening.

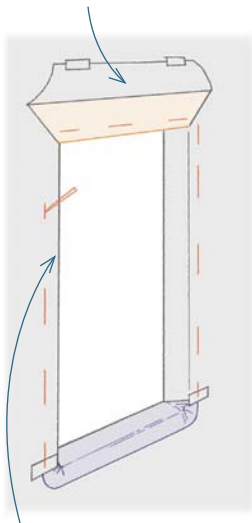

2 Make sure the perimeter of the opening is clean. Measure the distance the casing or nailing fin extends past the outside face of the window jamb, then, using a combination square, mark the perimeter of the opening.

STEP 2

Install the unit

2 Tilt the unit into the opening, and center it between the lines you marked with the combination square.

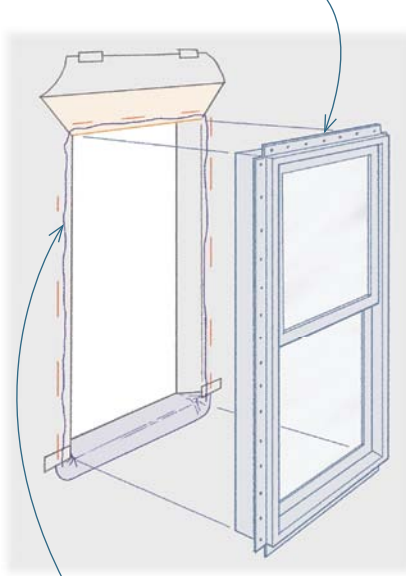

1 Run a bead of sealant up the sides and across the top of the opening.

3 Nail through the bottom corners of the casing or nailing fin to hold the bottom in place. Use 2-in. roofing nails for windows with nailing fins, or 12d casing or finish nails for windows and doors with applied casings.

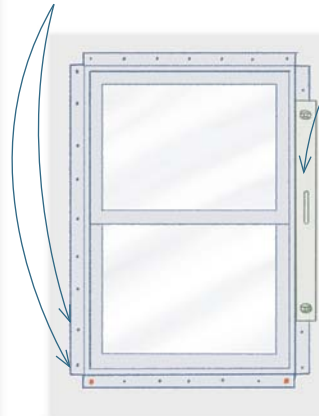

4 Place a level on the outside edge of one of the side casings or window frames (when hanging a door, plumb the hinged side of the doors). Move the top of the unit until the side is plumb, then place three or four nails in the casing or nailing fin to hold it in place.

Check the operation of the window or door as you nail off the other side. Finish nailing off the sides and the top. Place a nail every 8 in. or so. (On some "hinged flange" windows, you have to apply a nailing fin corner gasket to the top corners at this point.)

STEP 3 Shim the jamb, and finish attaching the unit

1 From inside, shim the jambs straight and plumb.

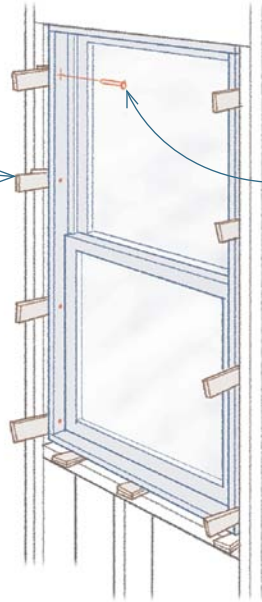

2 Nail through the jambs and shims and into the inside edge of the framed opening. (For more on shimming techniques, see chapter 9 on hanging interior doors, p. 354.)

WAYS OF WORKING

Primary and Secondary Barriers

The flashings under the sills and along the sides of windows are secondary barriers, designed to shed the water that gets through the primary barrier formed by the window or door and the surrounding casing and siding. If the primary barrier is working correctly, water flows down the face of the window or door, flows out over the sill, and runs down the outside of siding below. Along the vertical seams between the casing or raised edge of the window and the siding, water flows rapidly down the caulked joint. Assuming the caulking is sound, the water should not enter the seam.

In a carefully built and caulked exterior, very little water should reach the flashing installed along the sides and bottom of the opening. But even small leaks can cause serious problems that are difficult to fix. So installing flashing in these locations is the smart thing to do and is now required by code in many areas.

The flashing along the tops of windows and doors is not a secondary barrier. On the contrary, it's a key part of the primary barrier shedding water off the house. Water running down the siding above windows and doors flows, often in sheets, over the head flashing (also called drip-cap flashing) and out over the outside face of the window or door. If casing is used, the head flashing should be installed on top of the casing. There it directs the water to the outside face of the casing.

Because the tops of windows and doors are horizontal surfaces that interrupt the flow of water down the face of the wall, they are highly vulnerable points in exterior wall assemblies. The flashings at these locations handle large amounts of water and must be installed with care. It often makes sense to build in redundancy in these critical junctures.

Flashing the Sides and Top of the Unit

STEP 1 Flash the sides

Run a strip of peel-and-stick flashing vertically up both sides of the unit. Strips should overlap the sill flashing at the bottom and extend 4 in. to 6 in. above the top of the window. Use a flashing tape such as DuPont™ StraightFlash™ or Typar® Peel & Stick Window Flashing.

Peel-and-stick side flashing

STEP 2 Flash the top

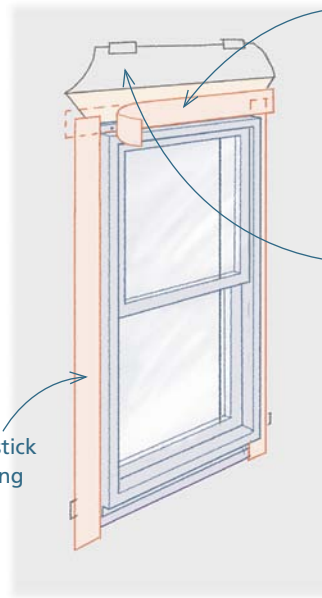

1 Install peel-and-stick flashing across the top of the unit. The tape should extend over the pieces installed along the sides of the windows. Flashing should fold over the top of the window casing or the top edge of the clad or vinyl windows.

2 Fold the WRB flap down and over the flashing, and apply seal tape to the diagonal cuts. If you want an extra layer of weather protection, however, proceed to the next step.

STEP 3 Install drip-cap flashing

For an extra measure of protection, install drip-cap flashing before folding the flap of WRB down and taping the corners.



1 Run a bead of sealant on the top of the window (or window casing) and on the wall.

2 Apply drip-cap flashing over the window or door. Use prebent aluminum drip cap, available at most building-supply stores, or PVC, such as SureSill™ HeadFlash™. (When using a rainscreen, you may have to use a brake or have aluminum drip cap custom-made.)

3 Nail through the vertical leg of the flashing with roofing nails to hold the flashing in place.

STEP 4 Finish up

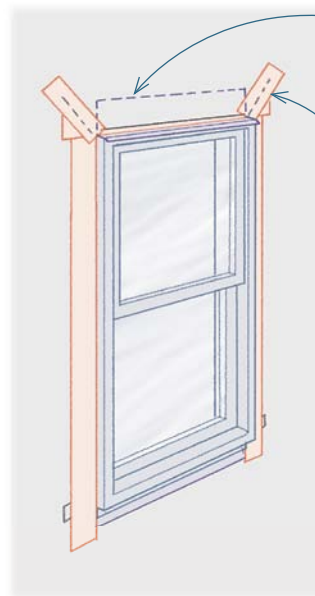

1 Fold the flap of WRB over the flashing.

2 Apply seal tape over the diagonal cut.

Flashing Wide Doorsills

Sills under large multidoor units, such as patio, French, or atrium doors, are especially vulnerable to leaks. Because the sills are so long, up to 12 ft., they cannot be supported solely by their connection to the jambs but typically must be fastened along their length to the bottom of the rough opening. These penetrations are weak points that are often breached by the water.

First, choose the right door. Some manufacturers place fastening points near the interior edge of the sill, where they are better protected from the weather. This is a better design than less-expensive doors that have the fastening points down the center of the sill. When you have to set a multidoor unit in an exposed location, choose a unit that places the fasteners toward the inside of the sill.

• FLASHING WIDE DOORSILLS

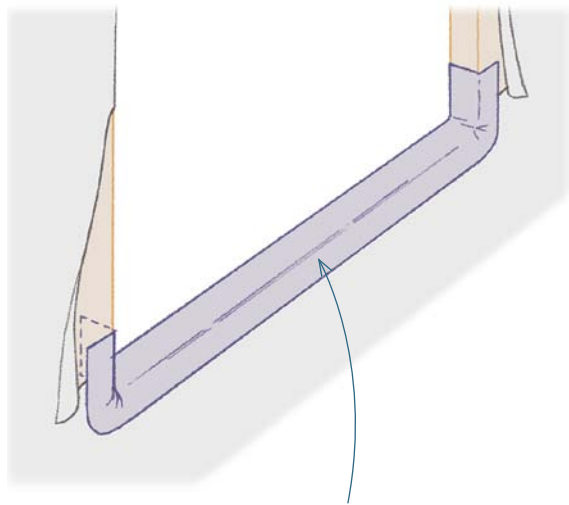

1 Flash the sill using either a flexible/conformable flashing (FlexWrap, for example) or a hard sill with molded corners (SureSill, for example). Avoid straight flashing, which must be cut and folded in place.

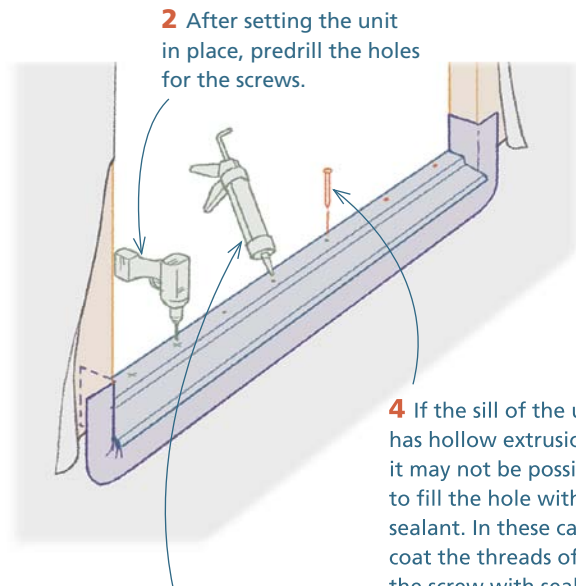

2 After setting the unit in place, predrill the holes for the screws.

3 Squirt sealant into the hole just before you install each screw.

4 If the sill of the unit has hollow extrusions, it may not be possible to fill the hole with sealant. In these cases, coat the threads of the screw with sealant before installing it. Make sure the sealant is compatible with the sill flashing.

Flashing the Tops of Arched Windows and Doors

To flash the tops of arched windows and doors, use a flexible flashing, such as DuPont FlexWrap™ or SureSill HeadFlash-Flex™. The following steps could be used with any type of siding.

• FLASHING ARCHED WINDOWS AND DOORS

STEP 1 Before installing the unit, cut the top of the WRB at an angle and fold the flap back

STEP 2 Install flashing on the sides

Extend the flashing up about 6 in. past the bottom of the arch. Fold the flashing up the raised edge of the unit or the edge of the casing.

STEP 3 Install the flexible flashing over the arch

If you're using FlexWrap, no sealant is required because this material is self-sealing. If you're using HeadFlash-Flex, apply an approved sealant to the window flange before installing the flashing. Install the flashing so that it wraps seamlessly over the arch and overlaps the two side pieces by at least 4 in. If you're using HeadFlash-Flex, nail it in place with roofing nails.

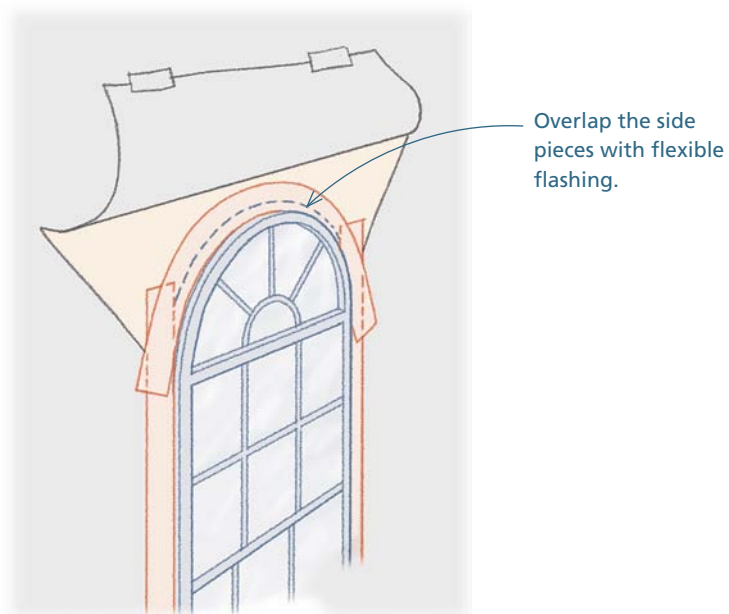
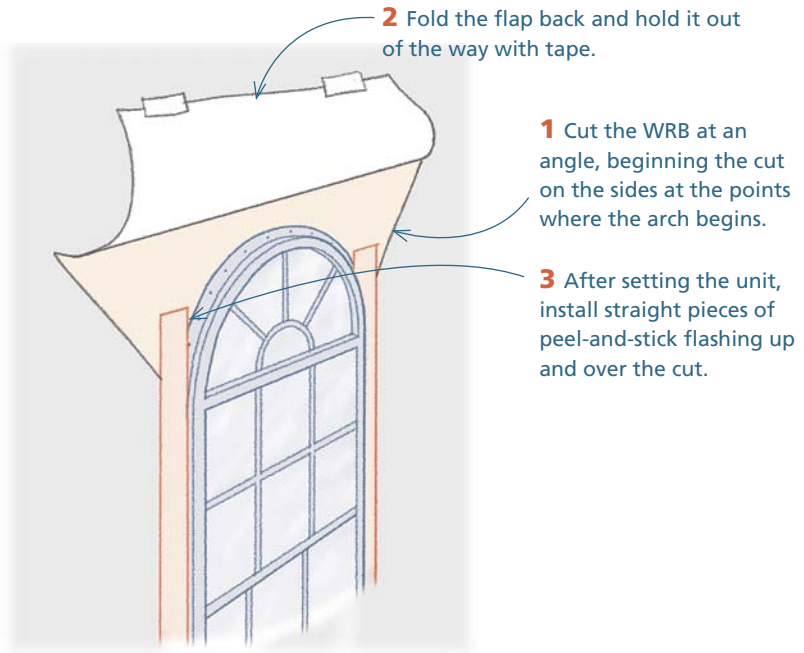

STEP 4 Reinstall the WRB

1 Fold WRB back over the window and trim to fit over the flashing.

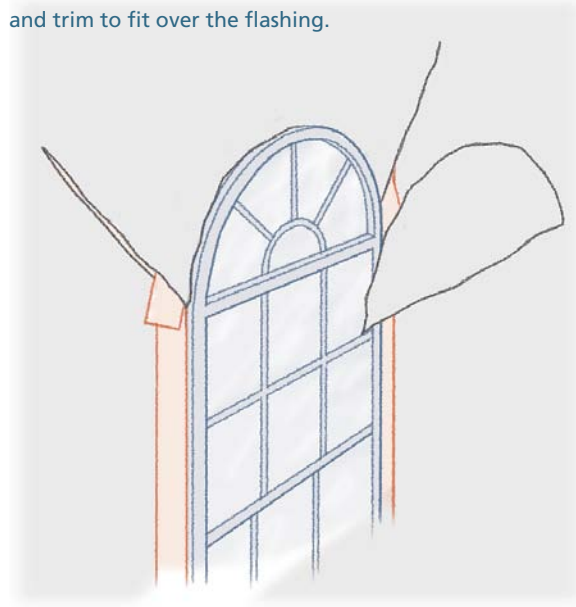

2 Tape the flap of the WRB back against the wall.

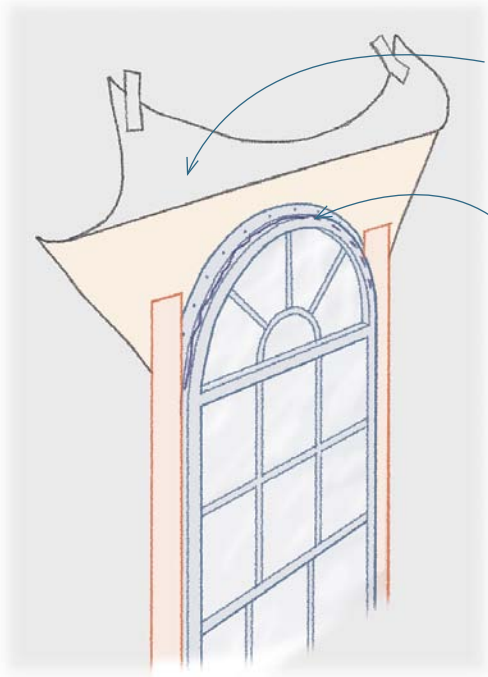

3 Run a bead of sealant over the top edge of the flashing.

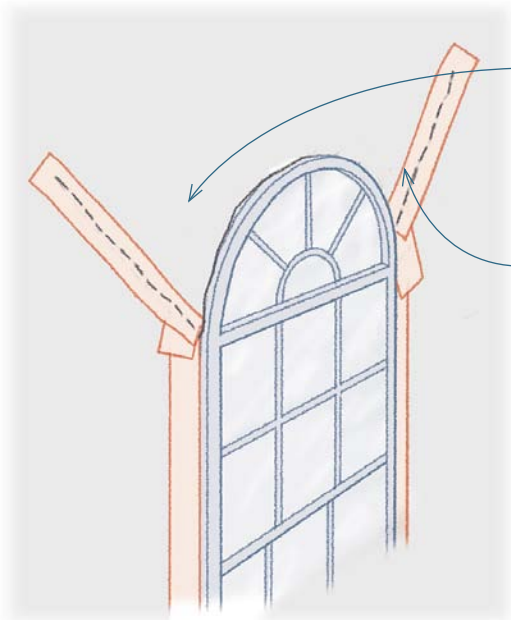

4 Fold the flap down again and press the bottom of the flap into the sealant.

5 Tape the diagonal cuts in the WRB.

Flashing Slope-Topped Windows

Typically, slope-topped windows are located on gables, with the pitch at the top of the window running parallel to the pitch of the roof. The bottom and sides of these windows should be flashed like any rectangular window.

Much of the water that runs down the wall above the window will run down the slope of the head flashing. This means that you should detail the lower corner of the head flashing in a manner that directs the water to the outside of the siding. (For information on how to get lapped siding coursed at the correct height to receive the flashing, see the section on lapped sidings on p. 263.)

STEP 1 Flash the sides and top of the window

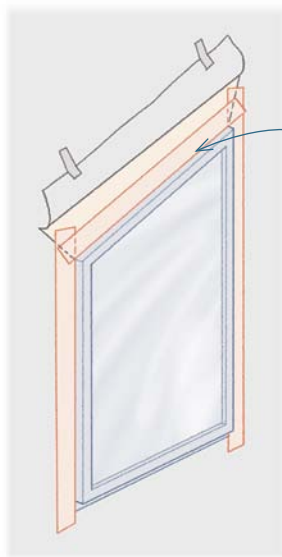

1 Use straight peel-and-stick flashing first, making sure it overlaps both the top edge of the window casing and the flashing on the sides of the window.

STEP 2 Run siding up the sides of the window

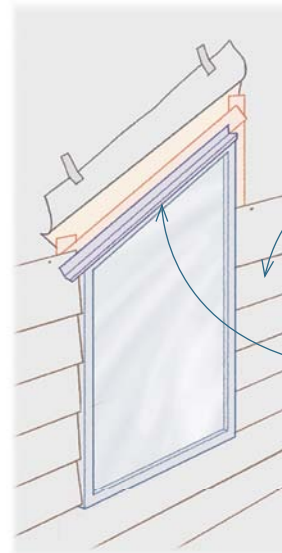

2 Install siding to the top of the window.

3 Install metal drip-cap flashing over the peel-and-stick flashing. Run the bottom edge of the metal drip cap over the siding.

STEP 4 Tape the seam

STEP 5 Continue siding up the wall

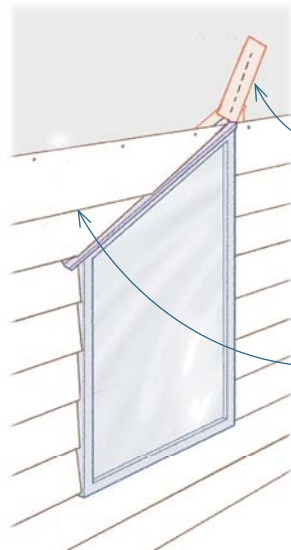

4 Apply sealant to the top of the drip-cap flashing. Fold the flap of the WRB down over the drip cap and press it into the sealant. Tape the WRB.

5 Install siding over the drip edge.

Flashing Octagonal Windows

One challenge in flashing octagonal (and round) windows is deciding which areas should be flashed like sills, which areas should be flashed like sides, and which areas should be flashed like head flashing. The best way to do this is to visualize how the water will flow off the siding above, over the window, then out over the siding below. Follow these steps:

STEP 1 Lap sill flashing over the WRB

Treat the bottom and the two adjacent sloping sides as the sill.

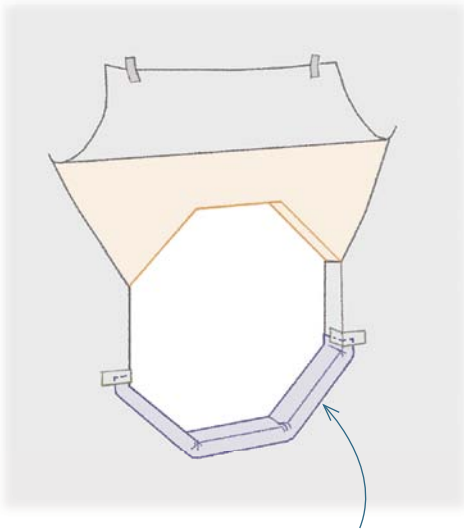

Lap the flashing over the WRB using a flexible peel-and-stick flashing, such as FlexWrap.

STEP 2 Tape the sides

Install the window, and treat the two vertical sides as the sides of the window.

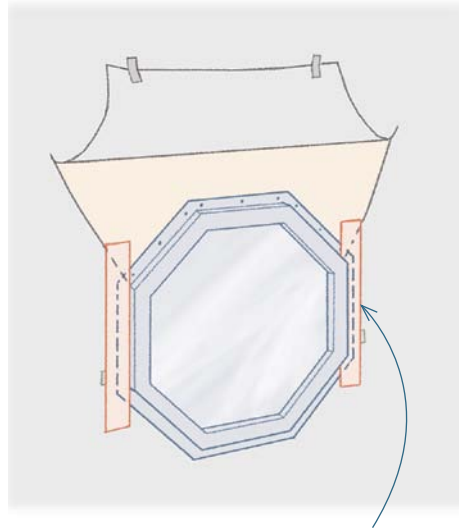

Lap the bottom over the sill flashing, and run the top 4 in. to 6 in. above the top of the side.

TOP TIP

Custom-Fabricated Drip-Cap Flashing

For octagonal or round windows, you can get custom-fabricated head flashing (aka drip-cap flashing) made up by a sheet-metal shop or a commercial roofing company. To avoid errors, make a plywood template of the top of the window or bring the window itself to the shop.

STEP 3 Tape the top of the window

Treat the level top and the two adjacent sloping sides as the head of the window.

Use FlexWrap (or a similar product) to flash the top.

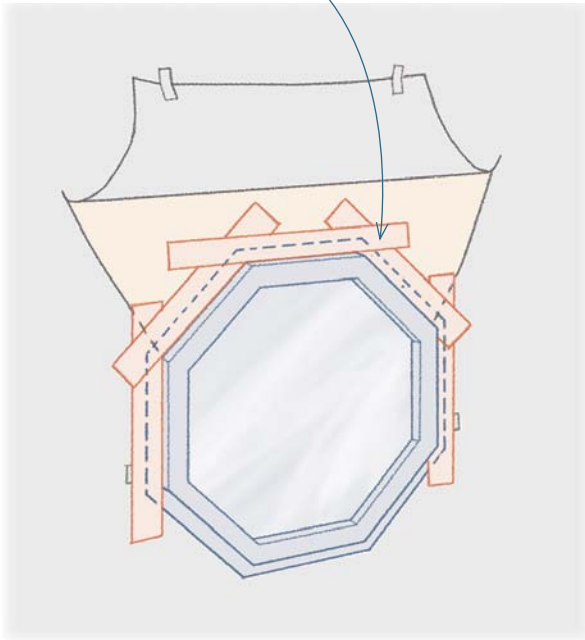

STEP 4 Run the siding and install the drip cap

When you run the siding, you can add a second layer of head flashing that runs out on top of the siding, as described in the section on slope-topped windows on p. 245.

Run the drip cap over the siding.

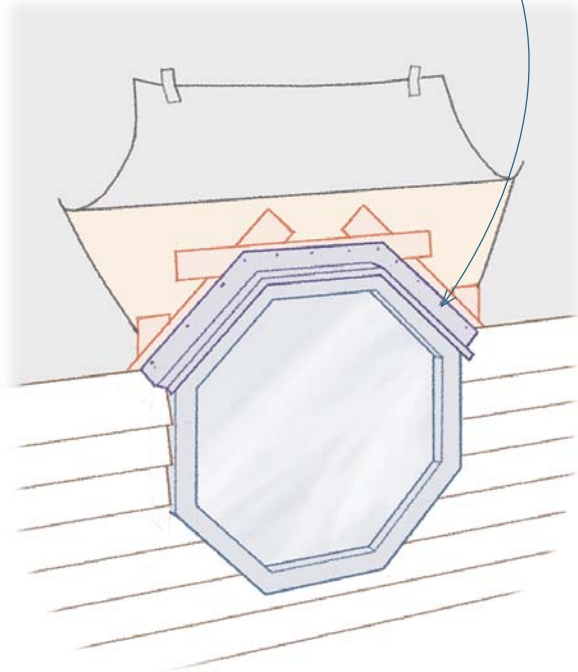

STEP 5 Fit the WRB to the top of the window

Add a bead of sealant to the head flashing, and reinstall the WRB. Tape the corners.

Press the flap into the sealant and tape the seam.

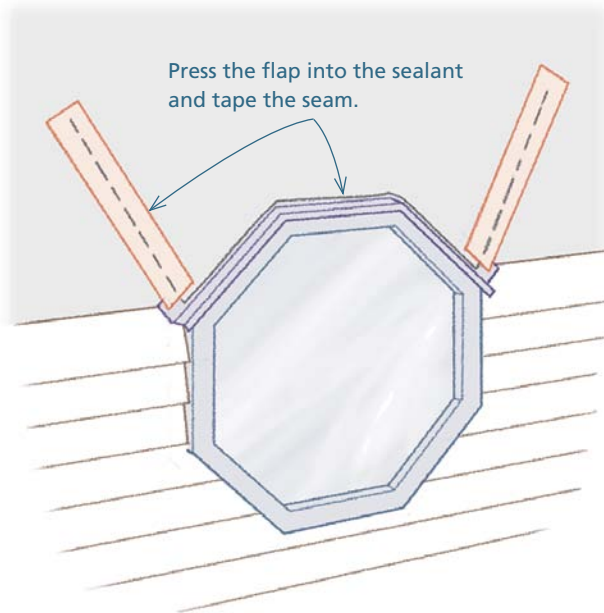

Flashing Round Windows

STEP 1 Lap sill flashing over the WRB

Treat the bottom half of the circular opening as the sill.

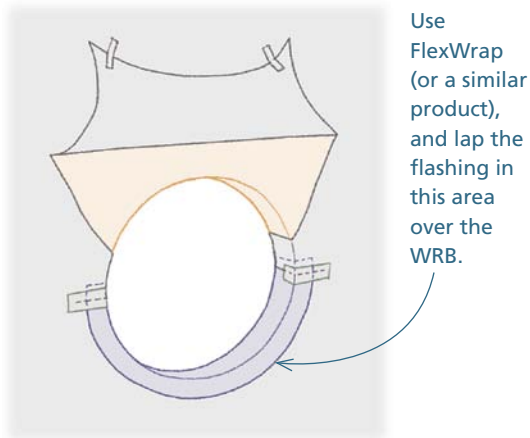

STEP 2 Flash the top

Treat the top half of the window as the head of the window.

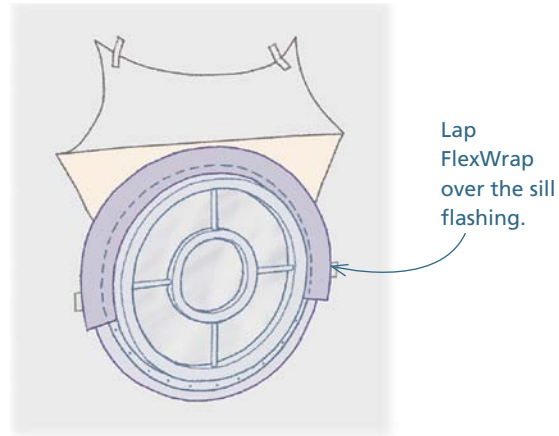

STEP 3 Side and install drip cap

When you install the siding, you may add a second layer of head flashing that runs out over the siding, as described in the section on slope-topped windows on p. 245.

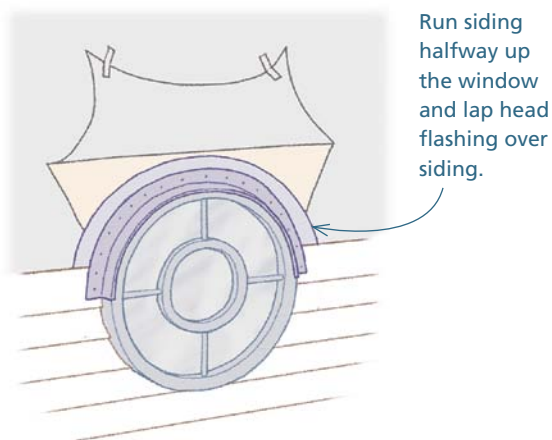

STEP 4 Fit the WRB to the window

Add a bead of sealant to the head flashing, and reinstall the WRB flap. Tape the corners.

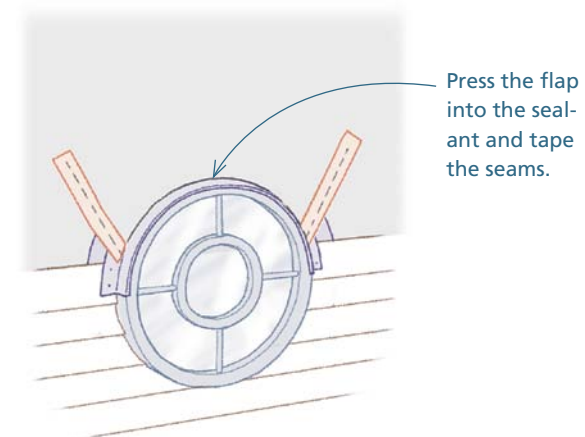

WAYS OF WORKING

Flashing Deck Ledgers

.....

The ledger of a deck is a horizontal board that's bolted to the house, often at the bottom of the wall. The ledger ties the deck to the house and helps carry roughly half the weight of the deck.

On most houses, a huge volume of water flows down the wall toward the deck ledger. If even a small percentage of this water seeps into the seam between the ledge and the frame, it can cause extensive rot. It's essential to flash this joint properly.

• WHAT TO AVOID

1 After installing the ledger and perpendicular joists, carpenters sometimes install an L-shaped metal flashing.

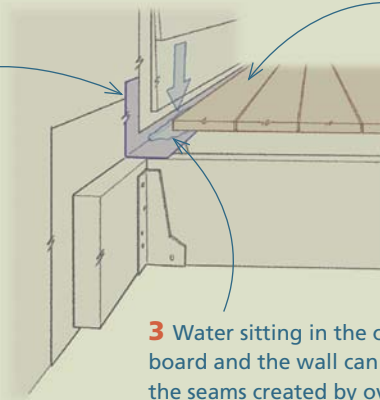

2 The first deck board installed closes off the space between the deck board and the wall. To make matters worse, carpenters sometimes create holes in the flashing when they nail the deck board to the ledge.

3 Water sitting in the channel between the first deck board and the wall can seep into the nail holes and into the seams created by overlapping pieces of flashing.

• GIVE THE WATER A WAY OUT

A better approach is to use a ledger that's wider than the joists.

2 Make up the flashing with an extra bend that goes down the face of the ledger the thickness of the deck boards.

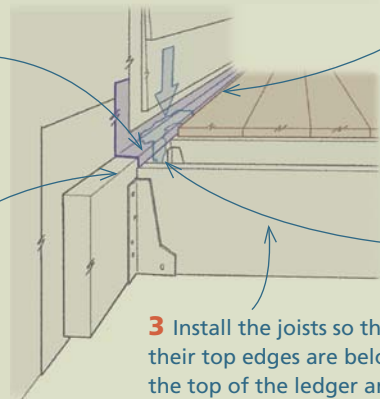

4 Install the first piece of decking along the wall with a $\frac{3}{4}$ -in. space between it and the ledger. The top of the deck board should be even with the top of the ledger.

1 Set the top of the ledger even with the planned top of the deck boards.

3 Install the joists so that their top edges are below the top of the ledger an amount equal to the thickness of the decking.

5 Water runs over the flashing and through the $\frac{3}{4}$ -in. gap and onto the outside face of the ledger.

• RUN DECK BOARDS PERPENDICULAR TO THE JOISTS

2 Make up the flashing with an extra bend that goes down the face of the ledge.

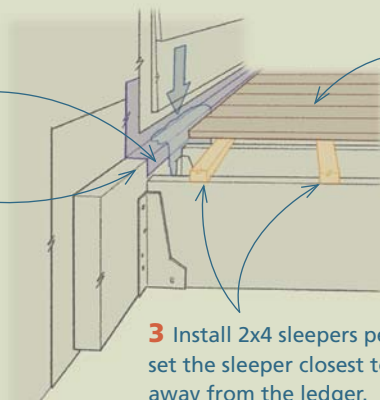

4 Install the decking on the sleepers perpendicular to the house, maintaining a $\frac{3}{4}$ -in. gap between the ends of the deck boards and the ledge.

1 To maximize drainage, use a ledger that's wider than the joists by an amount that equals the thickness of the deck boards plus $1\frac{1}{2}$ in.

3 Install 2x4 sleepers perpendicular to the joists; set the sleeper closest to the house about 3 in. away from the ledger.

Installing Exterior Trim

The edges of exterior siding have to be finished in a manner that's durable, waterproof, and pleasing to the eye. In some cases, these edges can be finished without using trim. Most of the time, however, trim is the easiest and most attractive option, and it's often used to finish eaves, rakes, corners, and the perimeters of windows and doors.

Trim systems vary enormously. Trim is affected by the size and shape of the eaves and rakes, the materials used for siding and trim, details for ventilation, the aesthetic goals of the designer, and the budget. Trim is generally installed before siding, and then the siding is fitted to the trim. There are a few exceptions to this general rule, however.

This section provides examples of a few of the most common trim systems. In most cases, the approaches shown here can be used to create other trim treatments.

Trimming Eaves

There are typically three parts to the eaves trim: the soffit, the fascia, and the frieze. In addition to these basic parts, some designs incorporate decorative moldings and a vent for the roof. Usually, the sequence of installation is not critical. Some carpenters, for example, like to install the soffit first; others prefer to install the fascia before the soffit.

Builders use a variety of materials to cover the bottom of the eave, including sawn lumber, plywood, aluminum, fiber cement boards, and vinyl. In the example shown here, the material is $\frac{1}{4}$ -in. plywood with a 2-in. vent down the middle, a common design.

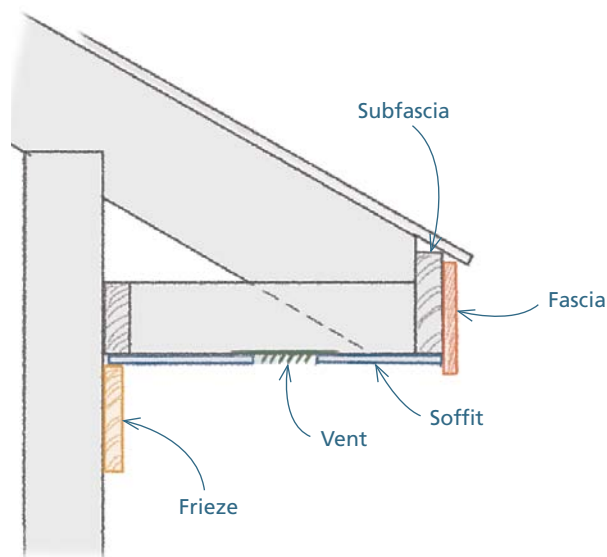

TOP TIP

Sealing End Grain

When you crosscut a piece of wood or fiber cement siding (or trim), the raw end grain provides an easy path for water to enter the material. To close this path, get in the habit of sealing the end grain. Use a brush to paint on primer or end-grain sealant after each cut. Doing so slows down the installation a bit, but it can lengthen the life of the siding considerably.

STEP 1 Install the soffit

1 Lay out the underside of the eave. In this example, the total width of the soffit is 16 in. The frieze is 1 in. thick. To center the vent visually, move the beginning of the layout 1 in. out from the wall. Find the center, then mark 1 in. out in both directions from the center mark. Do this at both ends, and strike a chalkline to finish the layout.

2 Rip the plywood. In this layout, the plywood should be ripped to widths of 6½ in. and 7¼ in. Adding these dimensions to the 2-in. width of the vent comes to 15¾ in., slightly less than the width of the framed eave.

3 Install the first strip of plywood. Set the 6½-in.-wide strips along the outside line, and attach them to the frame with 4d galvanized box nails. On the vent side of the strip, don't drive the nails tight, and keep the nails 1 in. or more away from the edge. Cut strips so they land in the middle of cross blocks. Leave a ⅛-in. gap between the butt ends of strips to allow for contraction of the frame (fill joints later with caulk).

4 Install the vents. Slip the flange of the vent into the seam between the plywood and the cross blocks, and slide it until the raised portion of the vent butts against the edge of the plywood. Drive the nails along the edge of the plywood tight. If necessary, install a couple of staples into the flange on the other side of the vent to help hold it up. Install vents along the whole length of the eave, butting the ends tightly together.

5 Install the second strip of plywood on the other side of the vent. Butt the plywood against the raised portion of the vent, and nail it in place with 4d galvanized nails. Run these pieces down the length of the eave, leaving ⅛-in. gaps between the pieces.

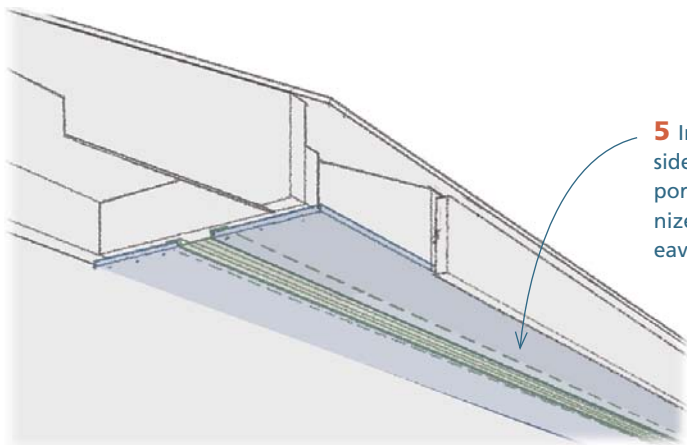
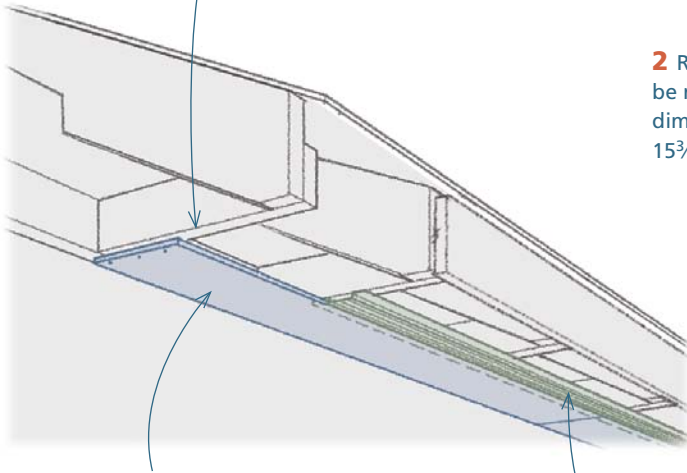

STEP 2 Install the fascia

Although some carpenters cut a 45° bevel at the ends of the fascia where it meets the rake, most make a simple 90° cut. This creates a more durable joint, and if a gutter is used, the joint is largely covered.

STEP 3: Install the frieze

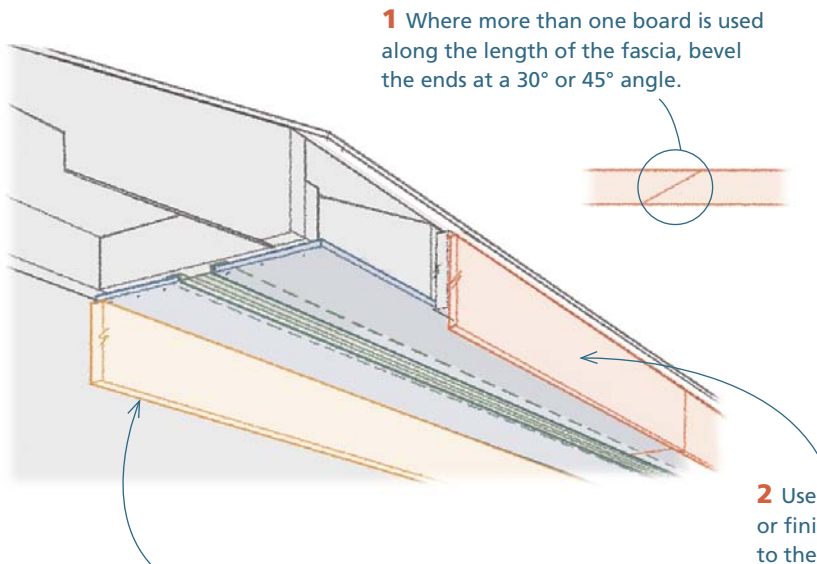

1 Where more than one board is used along the length of the fascia, bevel the ends at a 30° or 45° angle.

3 Make sure the end grain of the frieze will be covered by installing the vertical board first or by marking the width of the corner board on the wall and setting the frieze to the mark. As with the fascia, bevel the ends where boards meet, and use 12d casing or siding nails to attach the frieze.

2 Use 10d or 12d siding, casing, or finish nails to attach the fascia to the subfascia. Place a pair of nails every 16 in. to 24 in.

TOP TIP

In Carpentry, 5/4 = 1

.....
This frieze is made from 5/4x6-in. lumber, which is the same thickness as the planned corner boards. In the jargon of the lumber industry, a board that's a full inch thick is "nominally" 5/4 of an inch thick, just as a board that's actually 1½ in. by 3½ in. is "nominally" a 2x4.
.....

Trimming Rakes

There are four parts to the rake: the soffit, the rake boards, the rake returns, and the rake frieze. In the following example, the roof is a 7-in-12 pitch and the eave (which has already been trimmed) is 16 in. wide. The frame of the rake overhang is 16 in. wide (from the face of the sheathing to the outside of the frame). Both the fascia (already installed) and the rake board are made from 1x6 lumber.

STEP 1 Install the soffit

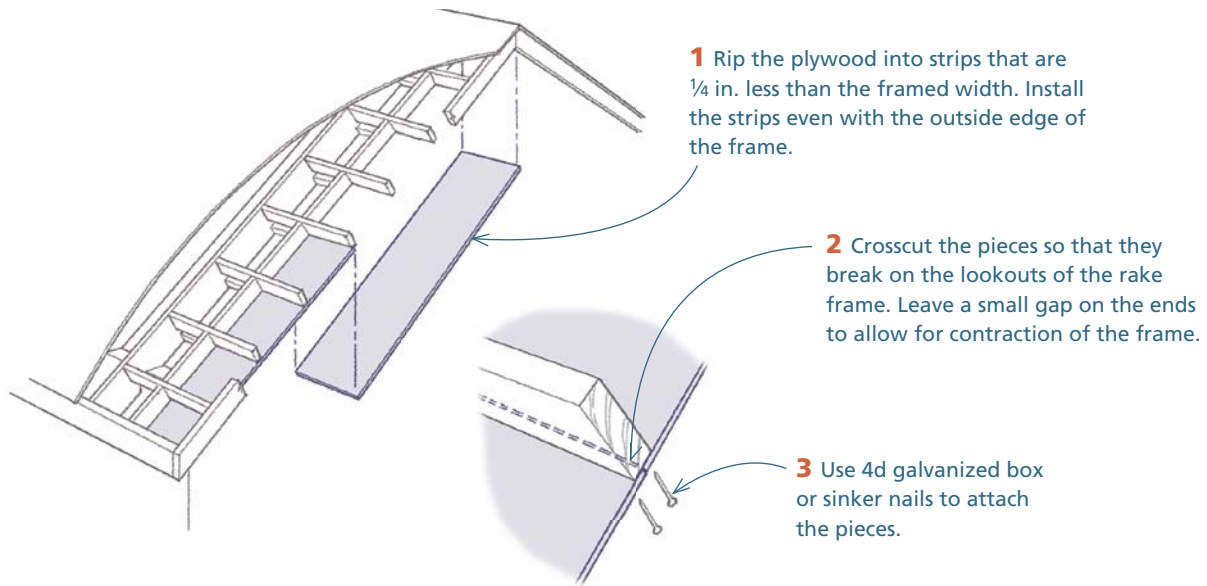

TOP TIP

Use a Rafter Jig for Angled Cuts

You can use a rafter jig (described in chapter 3) to lay out the angled cuts on the rakes, the rake returns, and the siding on gables and on any section that runs above a roof.

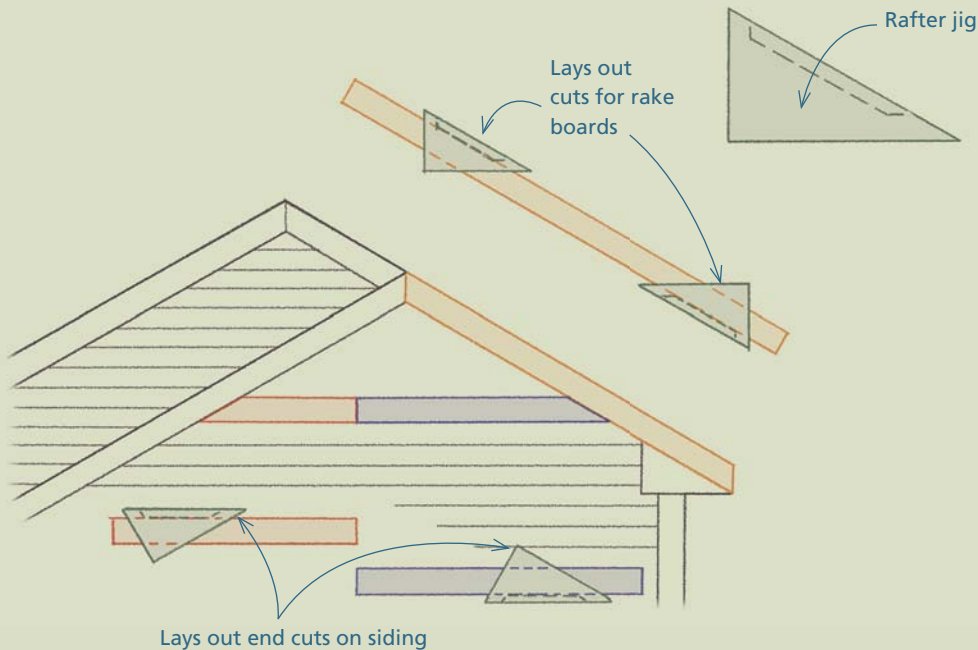

STEP 2 Install the rake boards

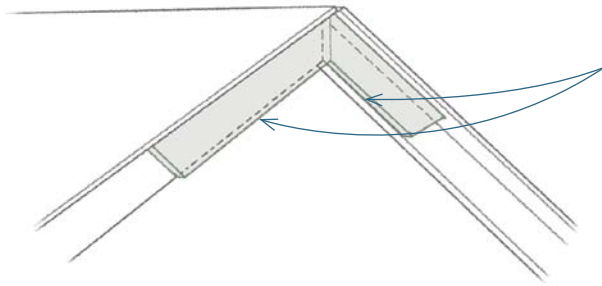

1 Mark and cut two scraps of the rake material to test-fit the joint at the top of the rake. Adjust the cut slightly until the two pieces fit tightly together. Note the precise angle of the cut.

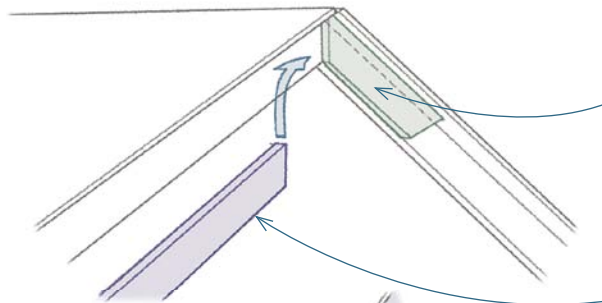

2 When satisfied with the fit, nail one of the scraps to the frame.

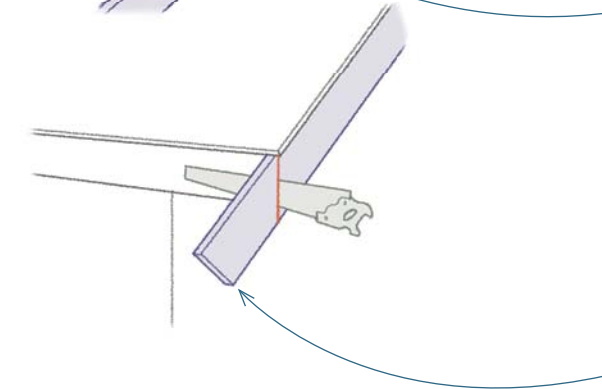

3 Mark and cut the top of the rake board at the angle noted above. Set the board in place with the top butted tightly against the scrap. Either nail the piece in place with the lower end running past the fascia or mark the end cut by scribing along the face of the fascia.

STEP 3 Install the rake returns

1 Mark a level line at the bottom of the rake board that's even with the bottom of the fascia by extending a line around the corner with a square. Cut along the line.

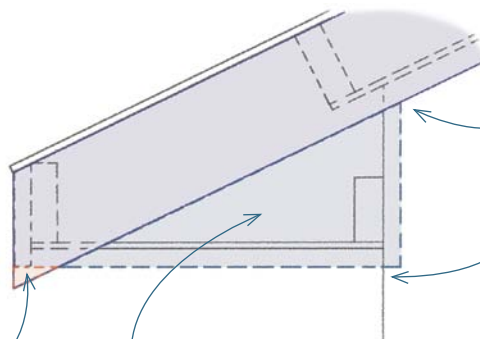

2 Install the back of the rake return. Bevel the top (here, at a 30.26° angle to match the 7-in-12 roof pitch). Cut the width so that it fits between the rake board and the wall.

3 Mark and cut the bottom so that it's even with the bottom of the fascia. Use 10d casing or siding nails to install the piece.

4 Install the triangular side piece. Cut the material at a 7-in-12 pitch. Check the fit, and trim if necessary to make a tight joint. Slide it in place, then scribe along the back piece. Cut along the line, and install the piece using galvanized 10d casing, siding, or finish nails.

STEP 4 Install the rake frieze

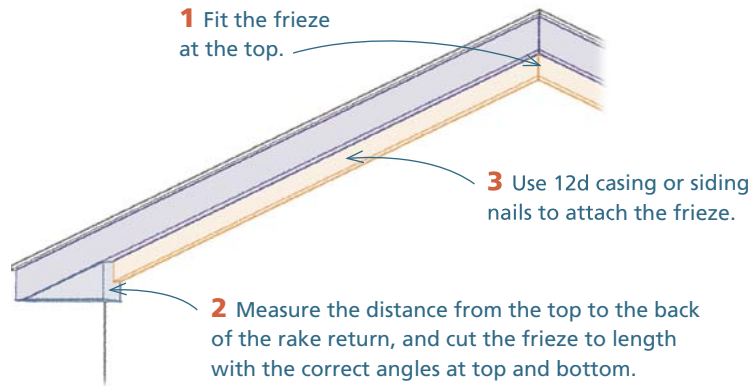

Trimming Corners

Because vertical corner boards are easy to install, relatively inexpensive, and aesthetically pleasing, they are the most common way to finish the corners of a house. (For a discussion of alternatives to vertical corner boards, see “Houses without Trimmed Corners” on p. 260.)

This section describes the installation of 4½-in. corners, which are commonly used with lapped siding. These corners consist of one piece that’s 5/4 x 4 with an overlapping 5/4 x 5, which makes both sides of the corner the same size. The rakes in this example are on a 7-in-12 roof.

STEP 1 Measure the length of the corner

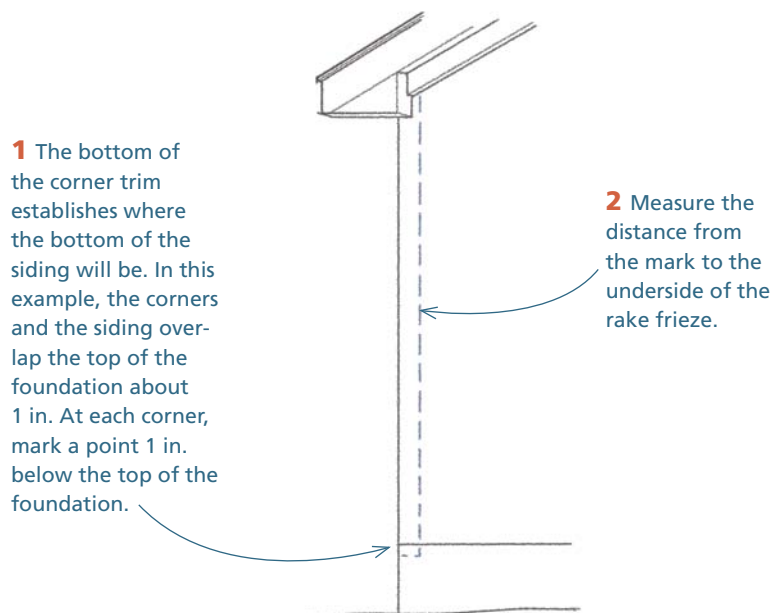

STEP 2 Cut and fit the back half of the corner

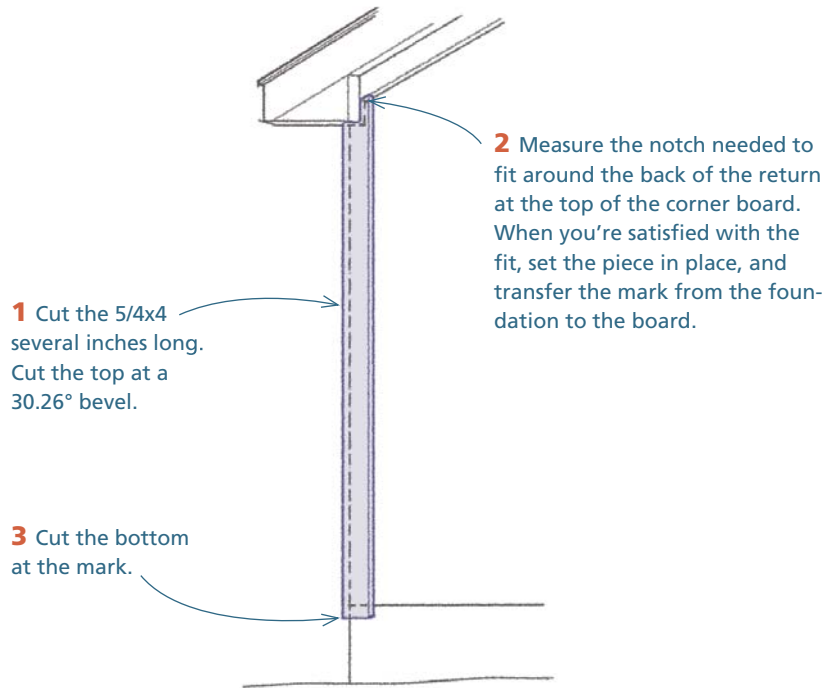

STEP 3 Install the back half of the corner

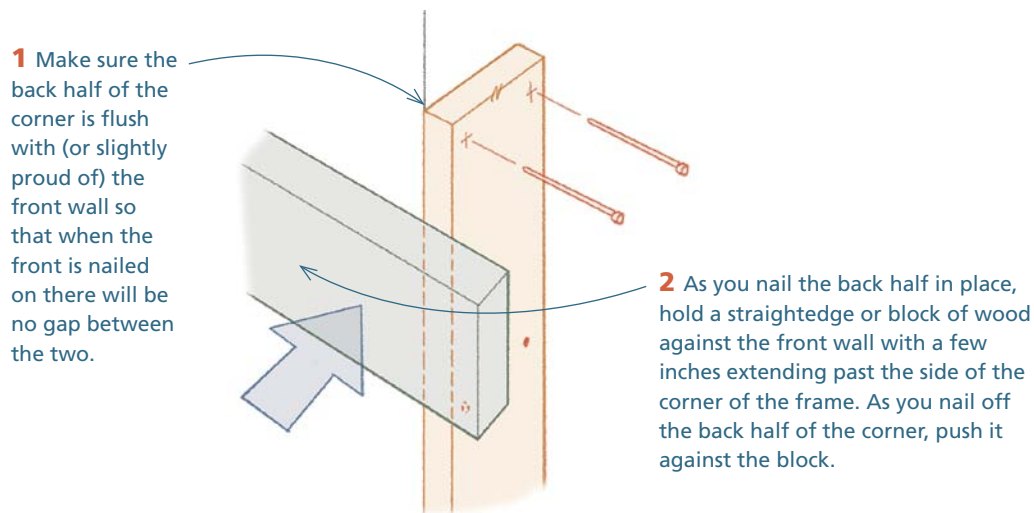

STEP 4 Install the front half of the corner

1 Measure and cut the 5/4x5. Hold the piece in place, with the top pushed up against the soffit of the eave. Mark the bottom even with the bottom of the back half of the corner.

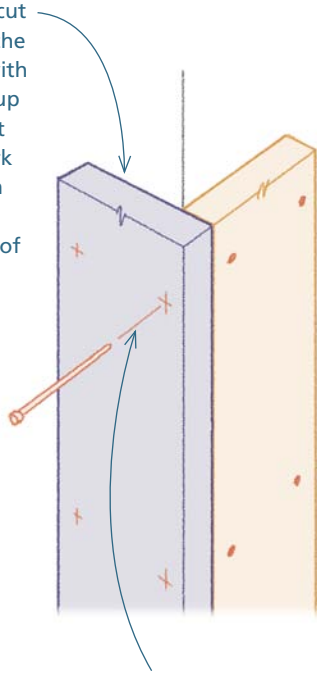

2 Nail the piece in place, with the edge flush with the face of the back half of the corner.

• RULE OF THUMB

Orient the beveled joint so that it sheds water.



1 When you have to use two pieces for very long corners, make 45° beveled cuts to join the pieces. Always orient the cuts so that the bevel on the upper piece overlaps the bevel on the lower piece.

2 Use 12d casing, finish, or siding nails. Pre-drill for the nails that join the two parts of the corner. Doing this keeps the nail from coming out on the face of the back half of the corner.

Trimming Clad-Wood and Vinyl Windows

Wood and fiberglass composite windows usually come with casing attached to the window. With most manufacturers, you can order windows with brick molding or flat casing. Some vinyl, metal, and clad-wood windows have a casing profile molded into the perimeter.

Many clad-wood and vinyl windows have a raised edge along the sides and top. In most cases, the siding is then butted to this edge. On many jobs, however, builders apply casing around the perimeter of these windows for aesthetic purposes. To seal this trim properly, follow the steps shown on pp. 261-262.

Houses without Trimmed Corners

Option 1: Brick and stone veneer

Not all siding systems use vertical trim boards on the corners. Although the corners of a brick- or stone-veneered house could be trimmed with vertical boards, the trim would look out of place and provide an avenue for water intrusion. A better way to accent the corners is to build features, such as quoins, into the masonry.

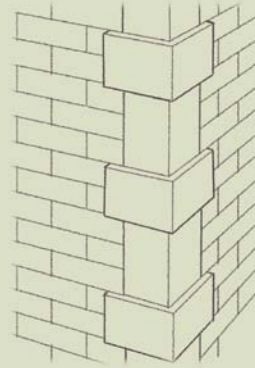

Option 2: Stucco

Houses clad in stucco rarely have vertical trim boards on the corners. On these houses, the corner boards would look awkward and be more prone to leaks than a continuous coat of stucco. Like masonry veneer, stucco walls sometimes incorporate corner treatments, such as quoins, in the stucco itself.

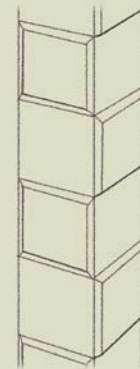

Option 3: Wood

Although most houses sided with wood shingles and clapboards have vertical trim on the corners, some designs don't use corner boards. Instead, the siding material is carefully joined at the corners, creating horizontal lines that continue, uninterrupted, around the corners. These treatments can be very handsome, but they are painstakingly slow and difficult to install. As such, they are usually more expensive than trimmed corners.



• TRIMMING WINDOWS

STEP 1 Cut and fold up the top of the WRB

1 After installing and flashing the window with straight flashing tape, extend the 45° cuts in the WRB at the top corners of the windows a few inches.

2 Tape the top flap up.

3 Install a strip of WRB over the flashing at the top of the window.

Straight flashing tape

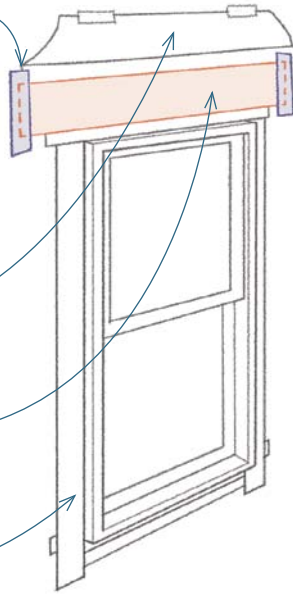

STEP 2 Install foam weatherstripping to the perimeter

To achieve a uniform gap and provide backing for the sealant, install a strip of self-adhering foam weatherstripping about 5/8 in. wide around the perimeter of the window. Set the weatherstripping about 1/8 in. in from the front face of the window edge.

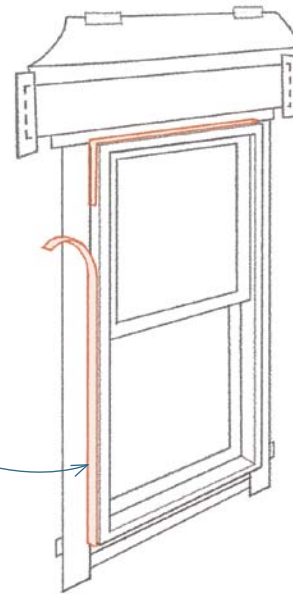

Self-adhering weatherstripping creates a uniform gap.

STEP 3 Install the casing

1 Cut and fit the casing around the window. Fit the pieces so that they lightly touch the weatherstripping, without compressing it.

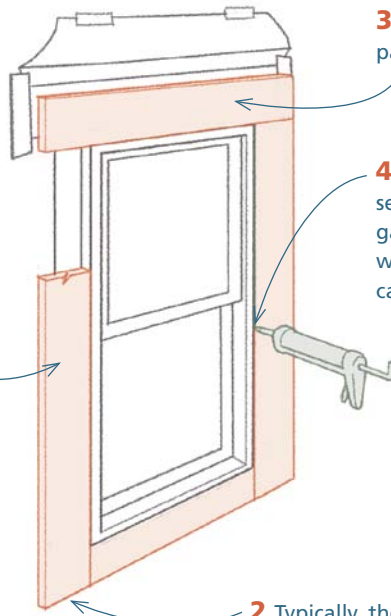

3 The top runs past the sides.

4 Use an approved sealant to seal the gap between the window and the casing.

2 Typically, the sides run past the bottom.

STEP 4 Install drip-cap flashing on top of the casing

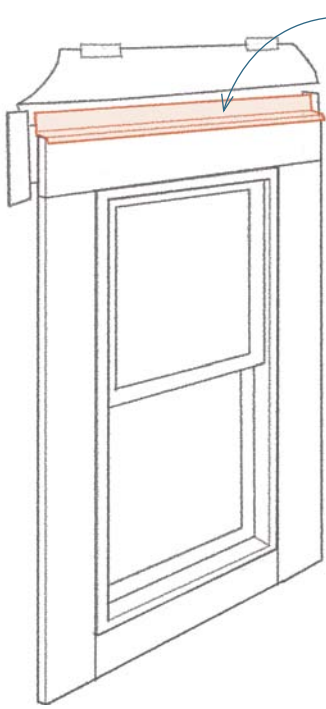

1 Install metal or vinyl flashing on top of the casing, using the techniques described in "Flashing the Sides and Top of the Unit" on p. 243.

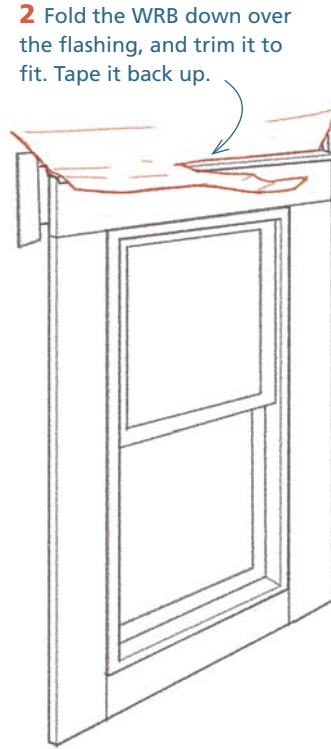

2 Fold the WRB down over the flashing, and trim it to fit. Tape it back up.

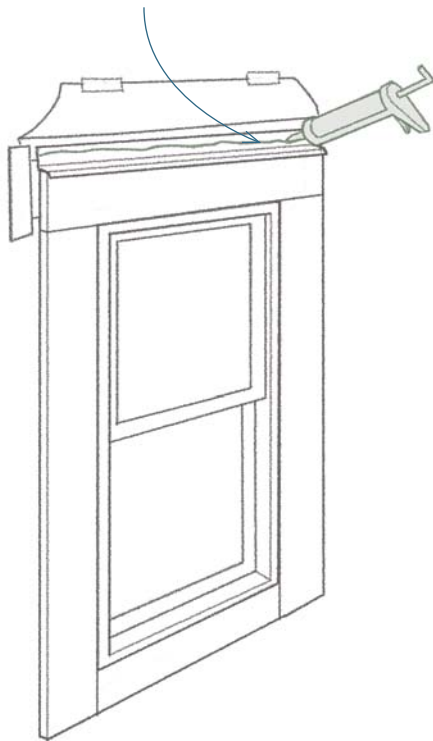

3 Apply an approved sealant along the top of the flashing. Fold the flap down, and press it down into the sealant.

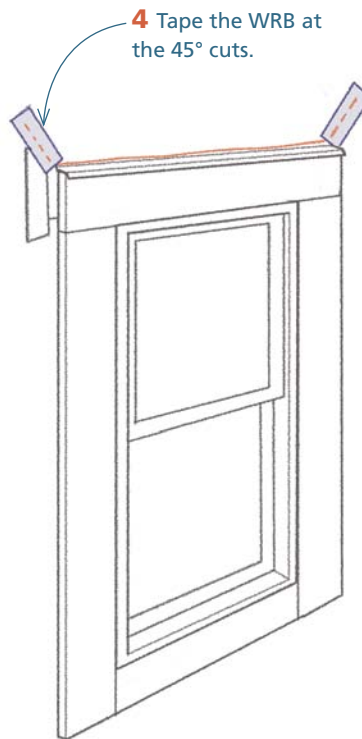

4 Tape the WRB at the 45° cuts.

Installing Siding

Builders use a wide variety of materials for exterior cladding. Along with traditional choices such as wood, brick, and stone, options now include plastics, composites, and metals. It's possible to group these divergent materials into a few basic systems. Within these systems, very different materials are often installed in much the same way.

Lapped Siding Systems (Horizontal Courses)

Lap sidings include wood boards sawn into several different profiles (square edge and tapered clapboards, Dutch lap siding), fiber cement siding, wood shingles, wood shakes, and slate and cement-based shingles. The overlapping pattern has a distinct advantage over other siding systems: The size of the courses can be compressed or expanded.

● SIDING PROFILES

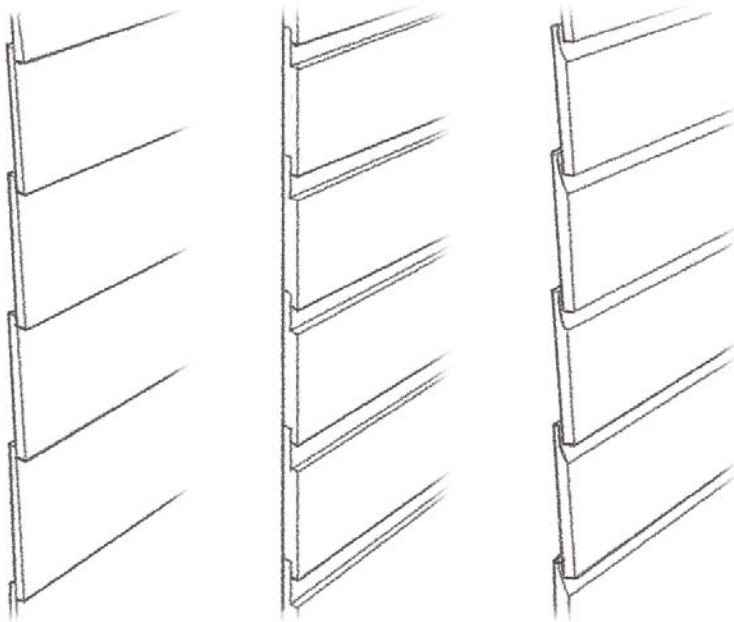

Clapboards

Shiplap

Dutch lap

Expanding or compressing courses: initial layout In this example, the siding is 8¼-in. fiber cement siding. The recommended exposure is 7 in. To expand or compress the courses, use the following procedure.

STEP 1 Mark the first course of siding

With fiber cement siding, the courses are usually laid out at the tops of the siding. At both ends, set a scrap of siding even with the bottom of the corner, and mark along the top of the scrap. Snap a chalkline from mark to mark to lay out the first course of siding.

STEP 2 Mark the desired landing point of the courses

In this example, the landing point of the layout is the top of the whole course above the window. To mark this point, hold a scrap of siding about ½ in. above the head flashing and mark along the top of the scrap. Mark the same distance up from the first course line at the other side of the space. Strike a chalkline from mark to mark.

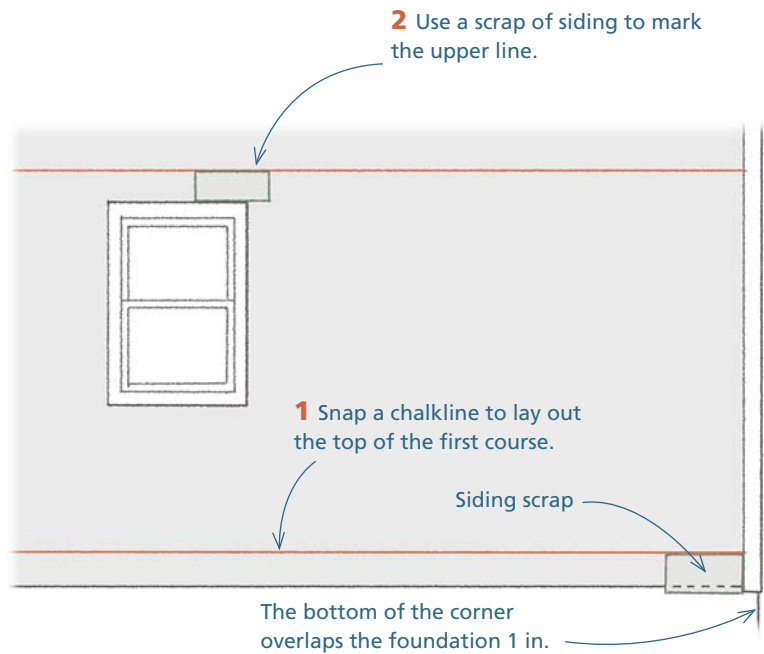

WAYS OF WORKING

Why Adjust the Size of the Courses?

.....

There are three reasons to adjust the size of siding courses.

First, it imparts a sense of order in the siding. If the tops of all the windows are set at the same height, for example, you can adjust the siding so that a full piece goes across the tops of the windows. This looks neat and orderly.

Second, it saves time. In the example just noted, there's no need to fit the siding around the window; a full piece runs right over the top.

Third, flashing can be installed in key locations so that it directs rain-water to the outside of the siding.

STEP 3 Calculate the number of courses

In this example, the distance between the line marking the top of the first course and the desired landing point of the layout is 93.5 in. The recommended exposure for the fiber cement siding used in the example is 7 in. Divide 93.5 by 7 to determine the number of courses desired: $93.5 \div 7 = 13.36$. This means you can either use 13 slightly expanded courses or 14 slightly compressed courses. In this example, 14 slightly compressed courses will be used.

STEP 4 Use the slant-rule trick to lay out the courses

Divide 93.5 by 14, which equals 6.68. Round the result up to the nearest whole number, which is 7. Multiply 7 by 14 to get 98. Multiply 7 by 14 to get 98.

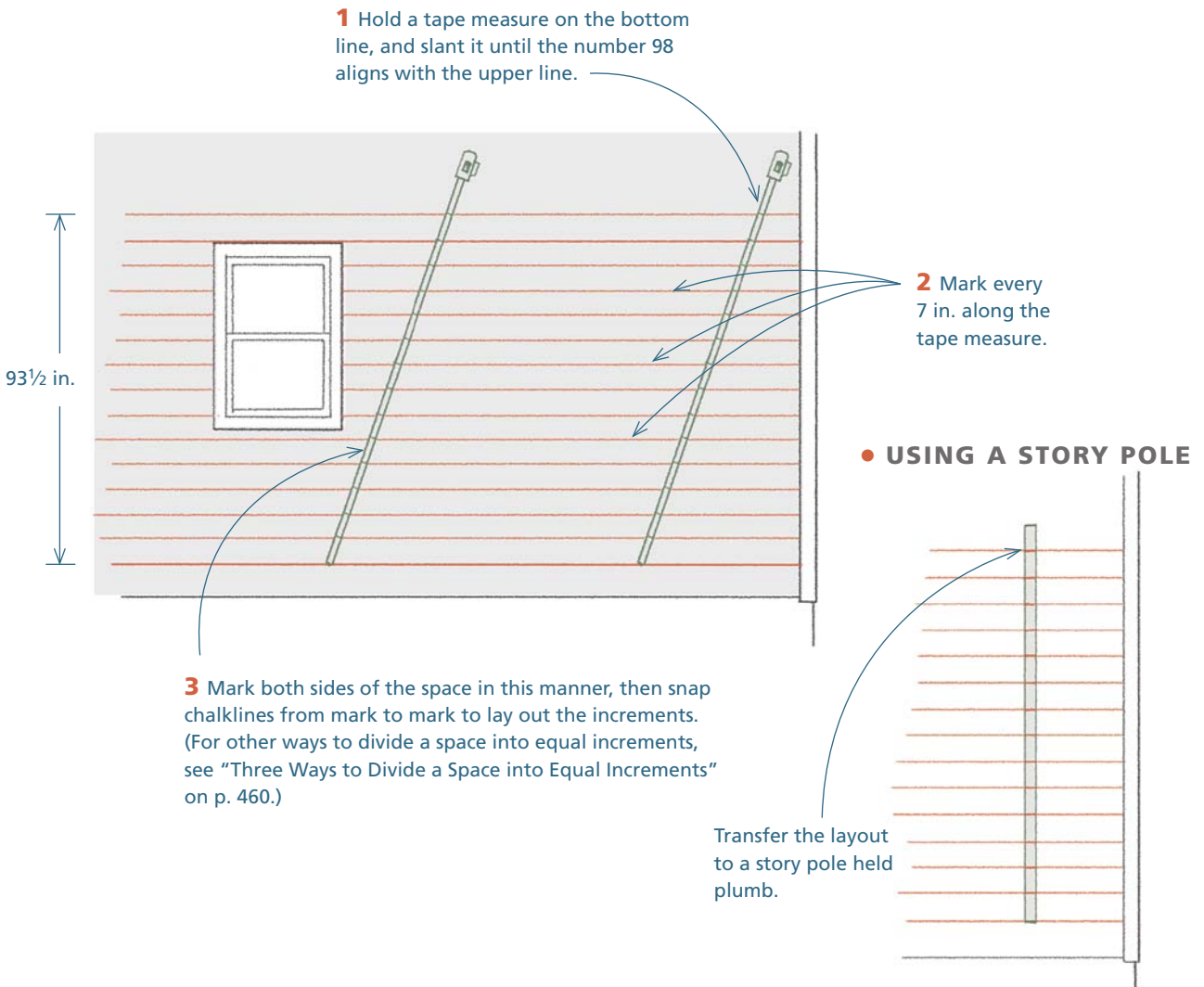

Using a story pole After marking the first section, transfer the layout to a story pole, and then use the story pole to mark subsequent sections (see the bottom right drawing on p. 265). Mark a line for the first course on all sides of the house, then set the story pole on the line to mark the section. In some cases, such as when running wood shingles, the first course is sometimes installed first and then the story pole is aligned with the bottom of the first course.

Nails for lapped siding The nails and the nailing schedule vary with the siding material that you use. Here are some common recommendations:

For wood siding, use 6d or 8d galvanized siding nails. Do not nail the top and bottom of the piece. (See “Save the Tight Joints for Inside the House” on p. 270.)

For cement board siding, you can face-nail the siding, as you would with wood siding. In areas not prone to strong winds, you also have the option of blind nailing in the area that will be covered by the piece above. For face nailing, use 6d to 8d galvanized siding nails. For blind nailing, use 2-in. roofing nails. Determine the amount that the course will overlap, and set the nails near the bottom of the zone that will be covered.

TOP TIP

Smaller Courses Allow Greater Adjustment

When you plan to adjust lapped siding, consider using a siding with a small exposure. The smaller the exposure, the more courses a given space will have. This permits a greater cumulative gain or loss with a slight adjustment per course.

WEAVING FLASHING INTO THE COURSES

One of the benefits of using lapped siding is that flashing can be run to the front of the siding, where it directs water to the outside of the wall. To take advantage of this feature, you have to lay out the courses so that they land at the correct height. The two most common places where this should be used are at the tops of windows and doors and at the bottom of a roof/siding intersection.

Flashing laps over siding.
The next row of siding laps over flashing.

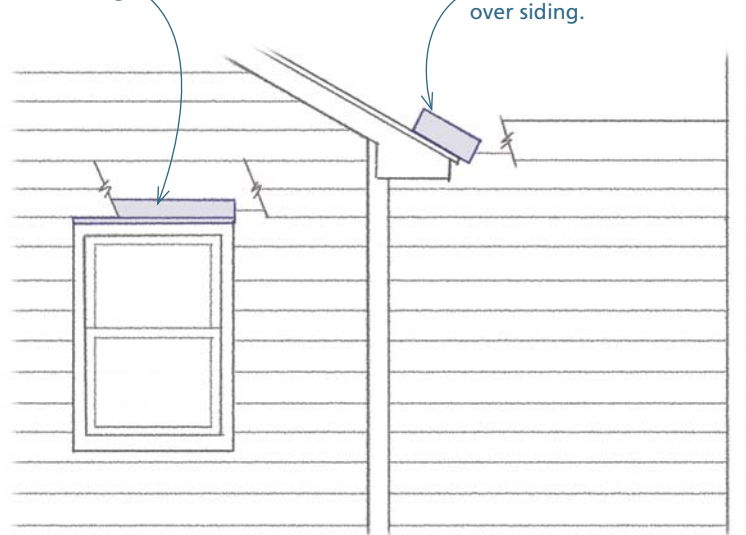

Lapped Siding Systems (Vertical Courses)

This group includes board-and-batten and shiplap sidings. Like horizontal lapped siding, the courses in these systems can be compressed and expanded; however, the amount of adjustment possible is usually smaller.

● GETTING THE NAILS IN THE RIGHT SPOT

3 To achieve this level of precision, mark the boundary of the zone before nailing. Set a combination square to the correct height, and mark the siding at each stud. Then, nail just above the marks.

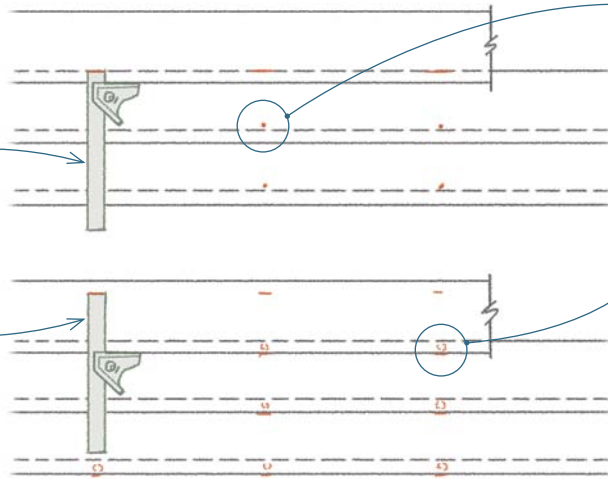

1 When you nail lapped siding at the bottom, the nail should go just above the top of the piece of siding below it.

2 When you nail fiber cement siding at the top, the nail should be as low as possible and still be covered by the next course of siding.

Vertical siding is oriented in the same direction as the studs of a wood-framed house. The traditional way to provide a surface to receive the fasteners for the siding is to nail horizontal sleepers perpendicular to the studs. Usually, the sleepers are nailed on the face of the sheathing (after it has been covered with the WRB). Doing it this way, however, creates a drainage problem. The cavities created by the sleepers are oriented the wrong way, and water that enters the cavities will be stopped by the sleepers as it flows down.

● INSTALLING BOARD-AND-BATTEN SIDING

The following offers one solution for draining a wall with board-and-batten siding. The same basic system can be used with vertical shiplapped siding.

1 Install the WRB over the sheathing.

2 Install $\frac{3}{8}$ -in. vertical furring strips over the WRB. Nail the strips vertically over each stud, along the perimeter of openings and at corners.

3 Install 2x3 sleepers perpendicular to the furring strips. Use fasteners long enough to go through the furring strips, sheathing, and at least $\frac{1}{4}$ in. into the studs.

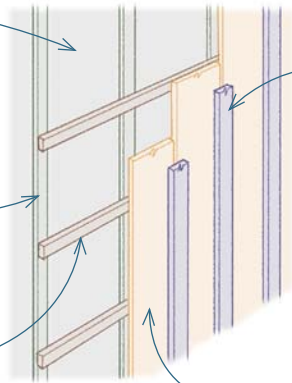

5 Nail the battens over the seams between the boards. Use one nail in the center of the batten. The nail should not go through the edge of either board; it should go through the seam between the battens.

4 Nail the boards up with galvanized nails. Use one nail per sleeper with the nail in the center of the board.

● VINYL TRIM

Several types of trim are available to finish vinyl siding and to anchor the ends against the wind. Like the siding itself, these pieces should be hung, rather than nailed tight. Install these trim pieces before installing the siding. The siding then slips into channels in the trim. The most common trim pieces are shown below.

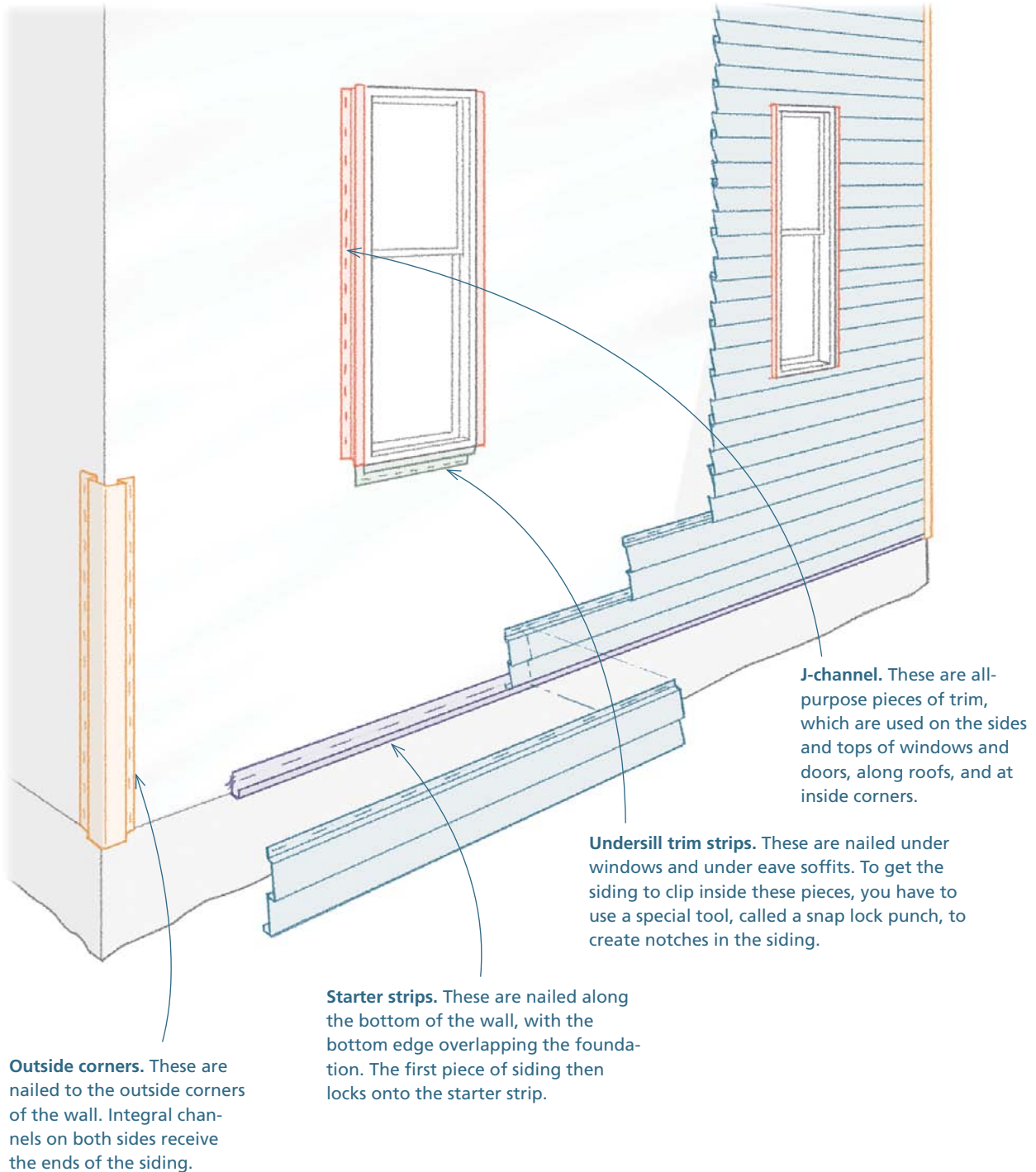

Outside corners. These are nailed to the outside corners of the wall. Integral channels on both sides receive the ends of the siding.

Starter strips. These are nailed along the bottom of the wall, with the bottom edge overlapping the foundation. The first piece of siding then locks onto the starter strip.

Undersill trim strips. These are nailed under windows and under eave soffits. To get the siding to clip inside these pieces, you have to use a special tool, called a snap lock punch, to create notches in the siding.

J-channel. These are all-purpose pieces of trim, which are used on the sides and tops of windows and doors, along roofs, and at inside corners.

Interlocking Siding Systems

Interlocking siding systems include horizontal vinyl siding, horizontal aluminum siding, and vertical steel, vinyl, and aluminum sidings. The size of the courses in these systems cannot be adjusted. This section looks at the installation of horizontal vinyl siding, which is the most common interlocking siding system.

Laying out vinyl siding To lay out vinyl siding, strike a level line around the house to guide the installation of the starting strip. Overlap the foundation $\frac{1}{4}$ in. Once this line is established, the layout is complete. Because the pieces interlock, there is no adjustment in the size of the courses.

Cutting vinyl siding Vinyl siding can be cut with snips, by scoring with a knife and bending the material back and forth, or with one of several types of power saws. You can use a circular saw, but, for crosscutting, a miter saw or a sliding compound miter saw is faster and more accurate. Use a small-toothed blade, such as a plywood blade. Mounting the blade backwards produces smoother cuts.

Nailing vinyl siding Use roofing nails long enough to penetrate at least $\frac{3}{4}$ in. into the studs of the frame. On a house with $\frac{1}{2}$ -in. sheathing, the nails should be $1\frac{3}{4}$ in. to 2 in. long. Vinyl siding should not be nailed tight to the wall.

Flashing vinyl siding The manufacturers of vinyl siding readily admit that it is not a watertight material. It is designed to shed most of the water that strikes it. To drain the water that gets past the exterior face, there are weep holes at the bottom of every piece of siding. Compared with other siding systems, it allows more water in but provides a better route out. At the tops of level windows, you usually can't lap the flashing over the siding (as is possible with lapped siding systems). Because of this, you have to rely on a careful flashing of the window that's tightly sealed to the WRB. Along roofs and slope-topped windows, use the methods described in "Protecting a Most Vulnerable Spot" on p. 276.

Plywood Panel Siding

Plywood panel sidings, such as T 1-11 and "reverse board and batten," are used mainly to save money. They are easy to install, and they can be used both as a siding material and as a bracing material for the frame. When used for shops and garages and low-cost housing, plywood panel sidings are often nailed directly to the studs of the frame.

(continued on p. 272)

TOP TIP

Hide the Lap

.....
 During installation along the sides of the house, always lap pieces toward the front of the house over pieces toward the back. This sequence makes it hard to see the overlap from the front of the house.

Save the Tight Joints for Inside the House

The exterior walls of a house are subject to freezing temperatures, rain, and scorching sun. In response to these changes, most siding materials expand and contract, some more than others. When two materials have to be tied together, this “differential movement” can damage one or both of the materials. In addition to dimensional instability, many siding materials need to dry to prevent a number of problems, including rot, peeling paint, and mold.

● ALLOW FOR MOVEMENT

To allow for movement, joints at key locations in the siding system should be left slightly open. Shown here are some ways to address these key locations.

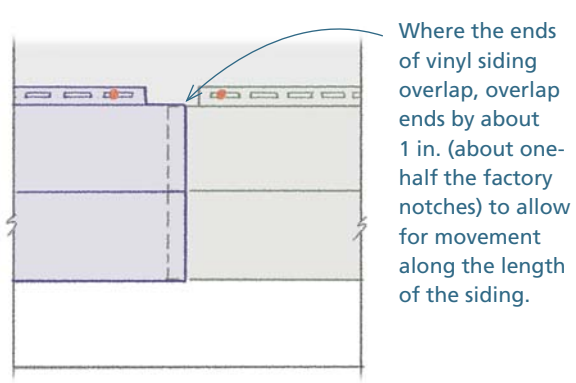
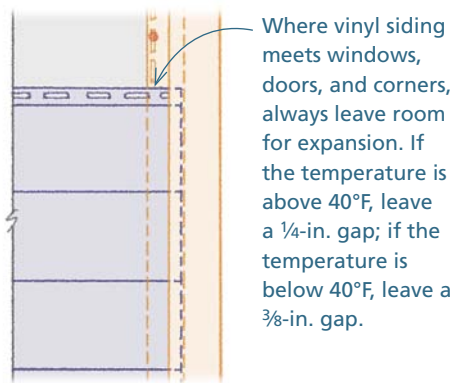
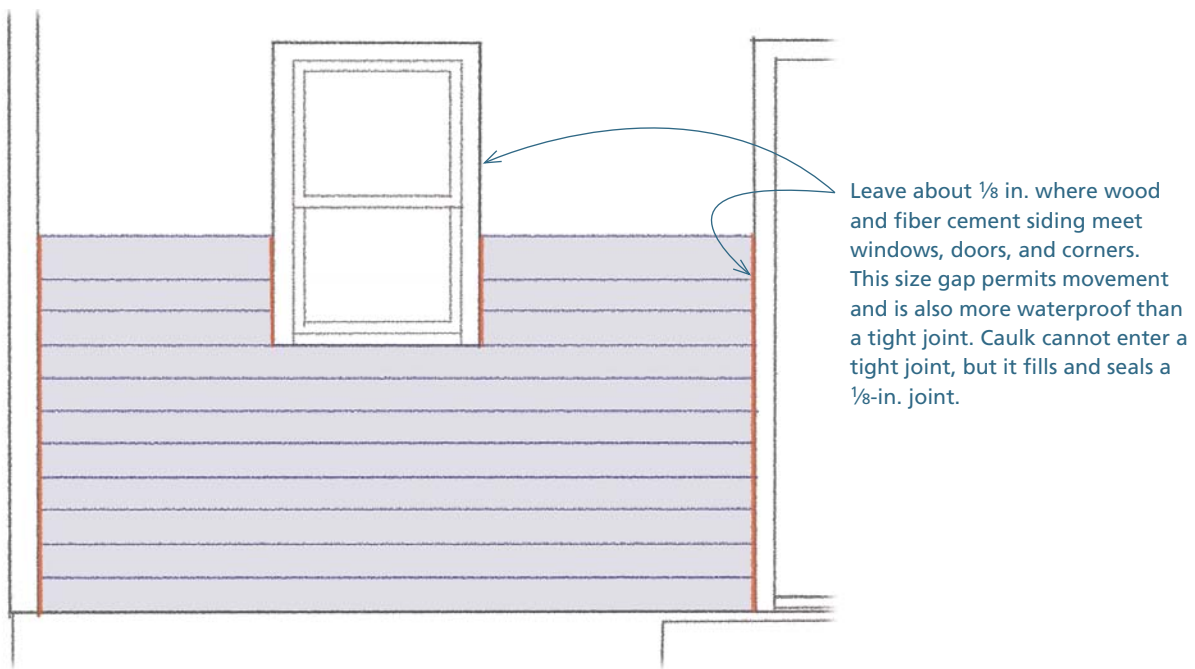

Where the ends of horizontal lapped siding meet, leave the final nail out when you install the first piece.

1 Slip a 2-in.-wide strip of #30 felt or aluminum behind the end. Cut the strip a bit longer than the height of the siding material, and make sure the strip overlaps the piece of siding below.

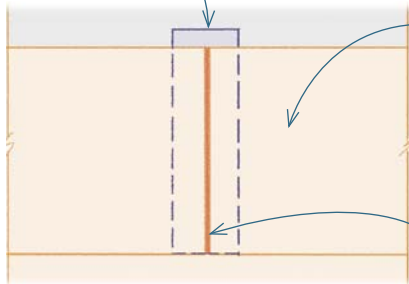

2 Install the next piece of siding with a $\frac{1}{16}$ -in. to $\frac{1}{8}$ -in. gap between the ends.

3 Fill the gap with caulk before painting.

• NAILING PATTERNS FOR WOOD SIDING

1 To prevent siding from cracking as it shrinks, nail just above the top of the piece below.

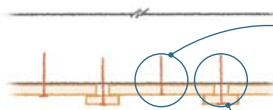
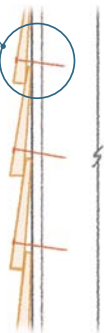

2 To avoid shrinking cracks in board-and-batten siding, place one nail in the center of the board.

3 When you nail the batten, place one nail in the center of the batten. This nail should go through the gap between the two vertical siding boards.

• NAILING VINYL SIDING

To permit the inevitable movement in vinyl siding, leave the heads of the nails about $\frac{1}{8}$ in. out from the sheathing and always place the nail in the center of the slot. Never nail the siding tight to the wall.

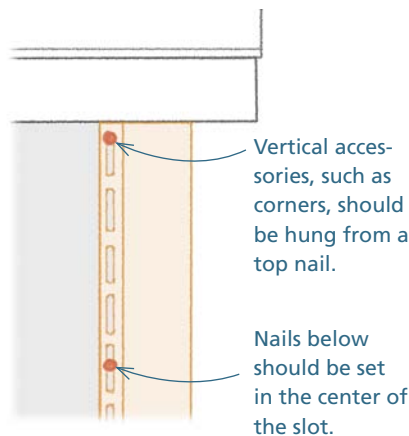

• WHERE BRICK VENEER MEETS DOORS AND WINDOWS

Leave a $\frac{1}{8}$ -in. gap between brick veneer and the molding around windows and doors. An easy way to do this is to apply self-adhering weatherstripping to the perimeter of the window or door before the mason lays the brick. Lay the bricks so they just touch the weatherstripping and later caulk the seam.

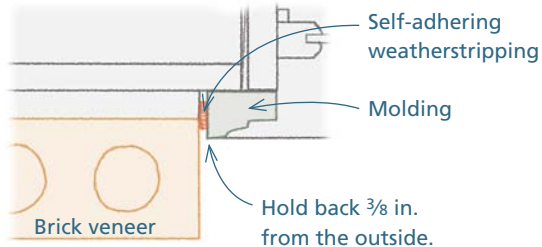

• WHERE STEEL LINTELS CROSS OPENINGS

Never bolt or nail the lintel for masonry to the frame of the house. The wooden frame shrinks and expands at a much greater rate than the masonry.

Always have the lintel clear the head of the window by at least $\frac{1}{8}$ in.

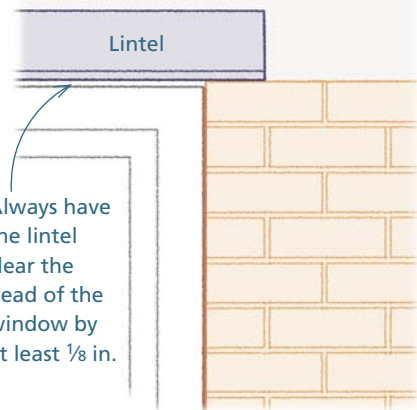

• WHERE SIDING MEETS A ROOF

Cut wood siding so that it's at least $\frac{3}{4}$ in. above the surface of the roof, and seal the ends before installation.

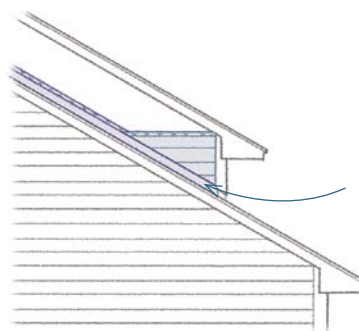

When using vinyl siding, J-channel is typically installed along the roof and the siding is inserted in the channel. Hold the J-channel up off the roof at least $\frac{3}{4}$ in.

● INSTALLING PLYWOOD SIDING

1 When foregoing sheathing, nail the WRB directly to the studs. For a better job, install sheathing and then the WRB.

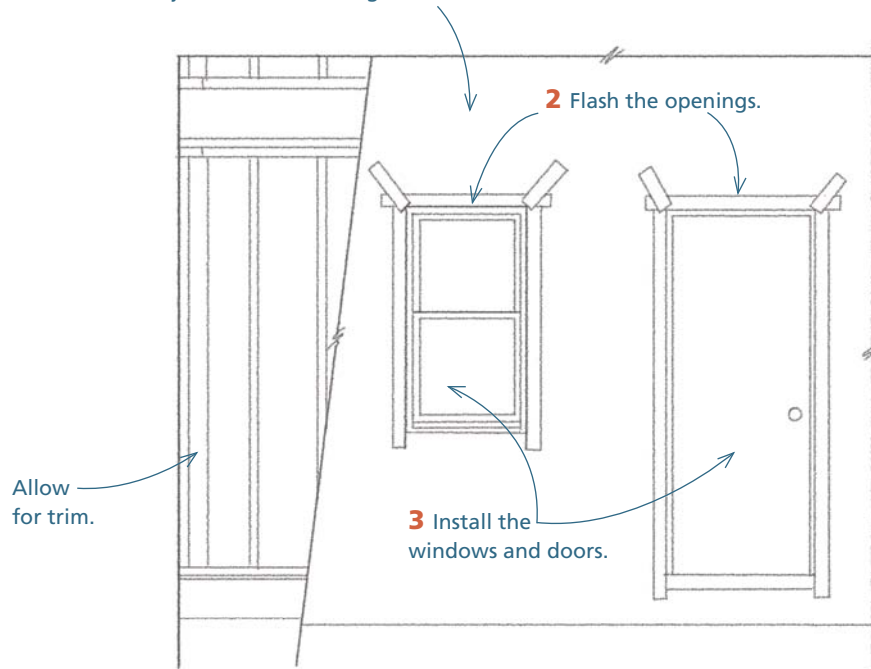

It's essential to provide backers at the perimeter of windows and doors and at corners to catch siding nails after the trim has been installed. Backers can be added as walls are framed.

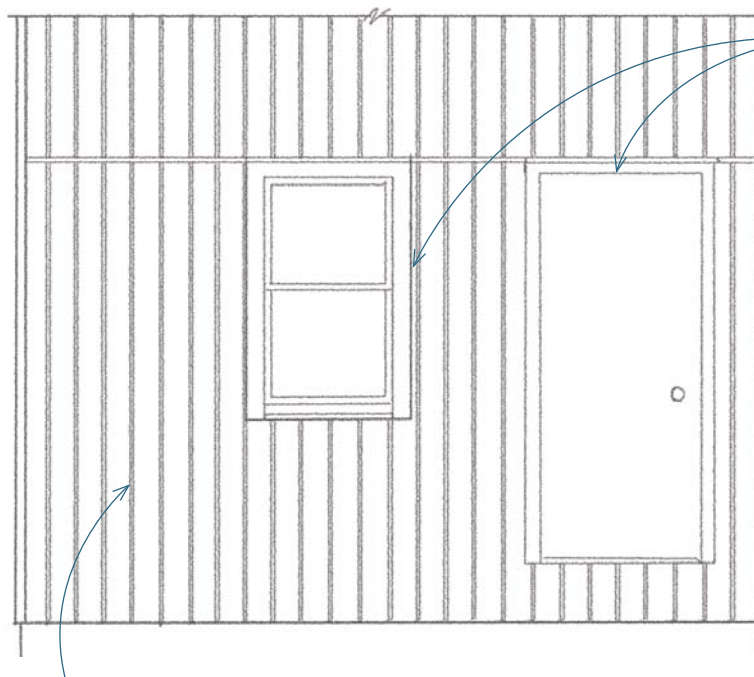

4 Install the trim on the windows, doors, and corners. Above window and door trim, install drip-cap flashing.

5 Install the siding. Cut the panels to fit between the trim on the windows, doors, and corners. Use 8d galvanized, box, siding, or casing nails. Nail every 6 in. along the edges and every 12 in. on intermediate supports.

● INSTALLING PANELS

As you go, coat any cuts with primer or end-grain sealant. Where the walls are taller than the height of one panel, you'll need to stack the second row of panels over the first.

Option 1:

Lap. Pad the wall out even with the first row of panels, then lap the second row over the one below.

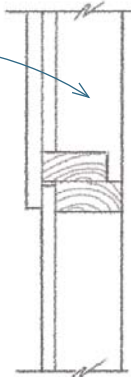

Option 2:

Butt and flash. A more common solution is to use Z-flashing. Set the Z-flashing on the top edge of the first panel, then place the bottom of the upper panel $\frac{1}{4}$ in. to $\frac{3}{8}$ in. above the top of the lower panel.

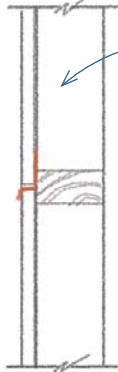

Overlap the ends of Z-flashing 3 in. Apply sealant in the area where the sections overlap. To optimize the flashing, plan to have the horizontal seams land even with the tops of windows and at other key locations, such as at the bottoms of roof/wall intersections.

Stucco and Masonry Siding Systems

Stucco and masonry siding systems require plastering and masonry skills that few carpenters have. Specialty contractors usually handle these materials.

In and of themselves, these siding materials are tough and durable. They typically last, with little or no maintenance, for the life of the house. When problems do crop up, they are usually in the frame behind the siding. Both stucco and masonry absorb water, so if they aren't drained properly, the water can damage the frame of the house. For this reason, the focus of this section will be on how to manage water.

● STUCCO

Stucco is a portland cement-based plaster installed over a drainable WRB and reinforced with wire lath. The basic steps for installing stucco are shown at right. Make sure that openings are flashed correctly.

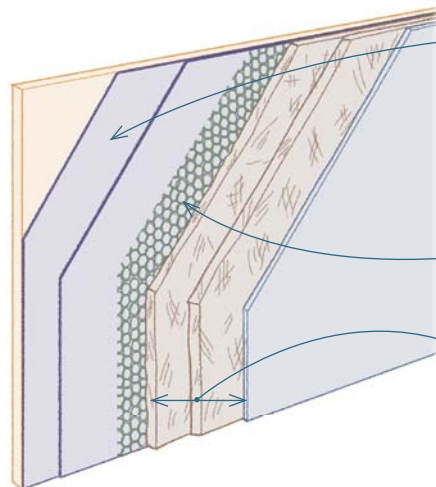

1 Install a drainable WRB. Use a WRB designed for stucco (Tyvek® StuccoWrap®, for example) or two layers of roofing felt. When two layers are used, the outer layer protects the inner layer from the stucco and water runs down the seam between the two layers.

2 Install wire or fiberglass mesh.

3 Install the three coats of stucco—the scratch coat, the brown coat, and the finish coat.

• MASONRY SIDING SYSTEMS

Masonry siding systems include brick and stone veneer. These systems are tied to the frame with corrugated wall ties that are nailed to the house and embedded in the mortar joints.

Drainage is achieved by attaching a WRB to the sheathing and by creating a drainage plane behind the veneer. With brick and stone of uniform thickness, masons can simply build the veneer 1 in. or more away from the wall. This creates a uniform space between the veneer and the frame.

With irregular stone, it is difficult or impossible to keep mortar out of this cavity. In these cases, a drainable mat must be placed between the veneer and the wall of the frame. These have trade names such as CavClear®, MortarNet®, and WaterWay™.

After installing flashing at doors and windows, place weatherstripping around outside edges of frames, and take these steps:

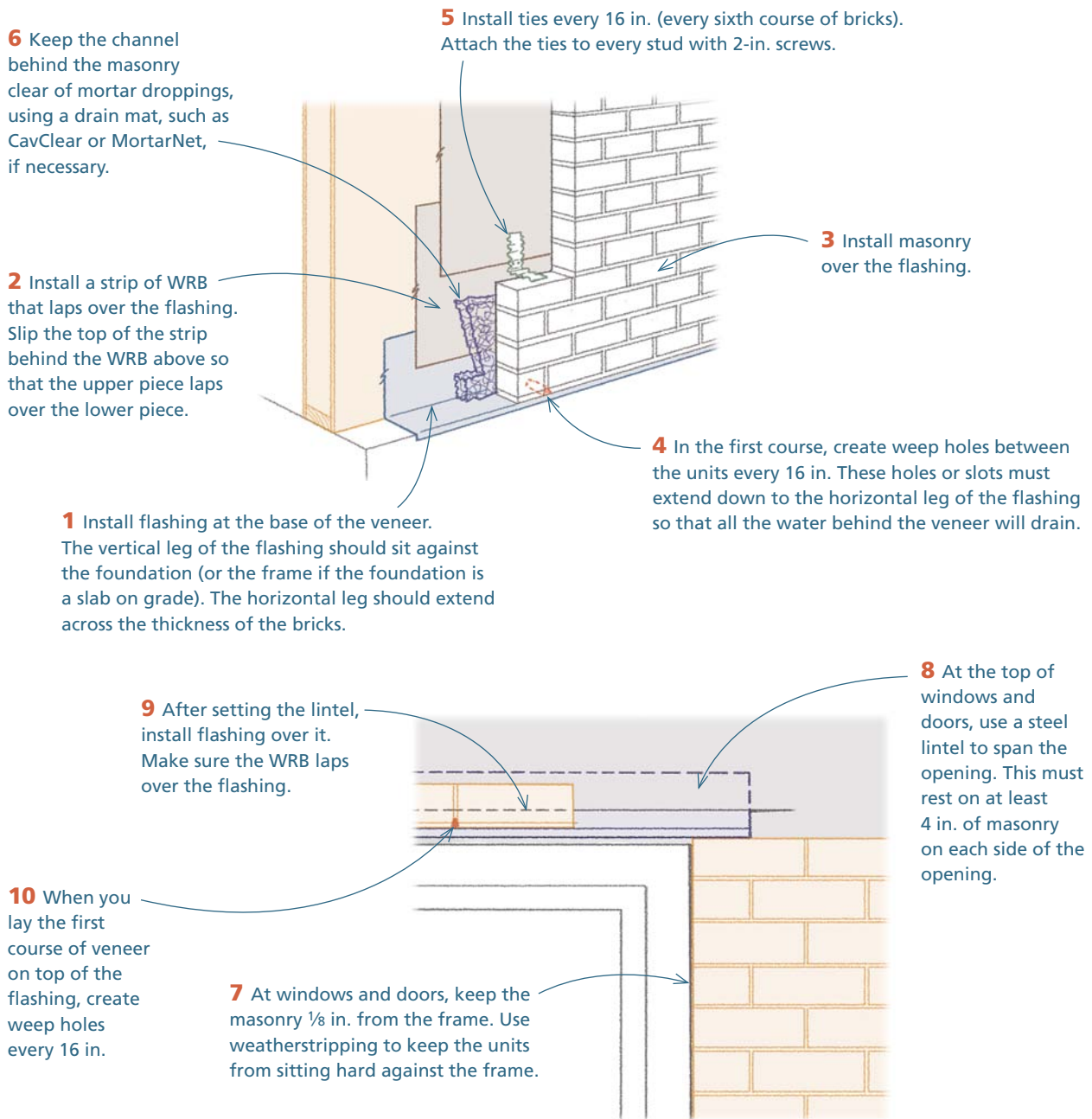

● INSTALLING CORRUGATED WALL TIES

2 Install the ties as you lay up the veneer with the vertical leg of the L pointing up.

1 Bend the wall ties into an L shape.

3 Place the fastener as close to the bend in the tie as possible.

5 Use 2-in. pan-head screws, not nails, to attach the ties. Pounding nails into the frame can break the bond in newly laid bricks below.

4 Make sure the end of the tie is at least $\frac{5}{8}$ in. in from the outside face of the veneer.

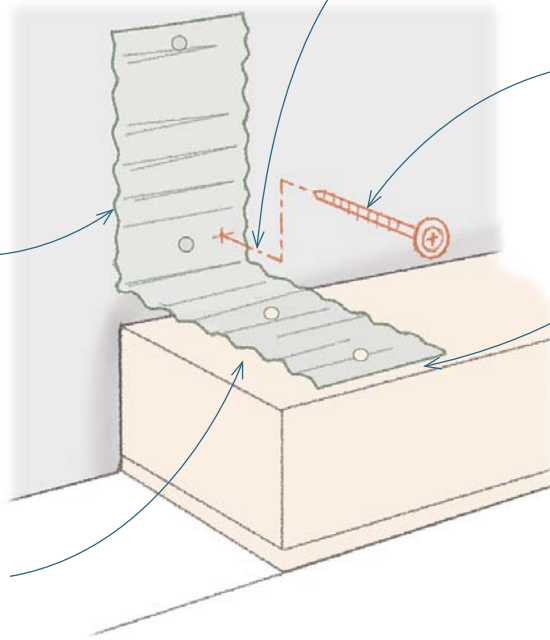

Protecting a Most Vulnerable Spot

On houses where a wall extends past the eave, the bottom of the roof/wall intersection is prone to leaks because the vertical leg of the flashing is behind the siding. Consequently, a lot of the water running down the bend in the flashing flows behind the siding at the bottom of the roof.

To block the path of the water, builders sometimes fill the lower end of the gap between the roof and the siding with caulk, which is prone to failure. A much better solution is to redirect the flashing at the bottom of the roof so that it runs out in front of the siding. Details vary with the type of siding used.

• HORIZONTAL LAPPED SIDING

The critical detail is to get the siding courses to work out at the correct elevation for the flashing.

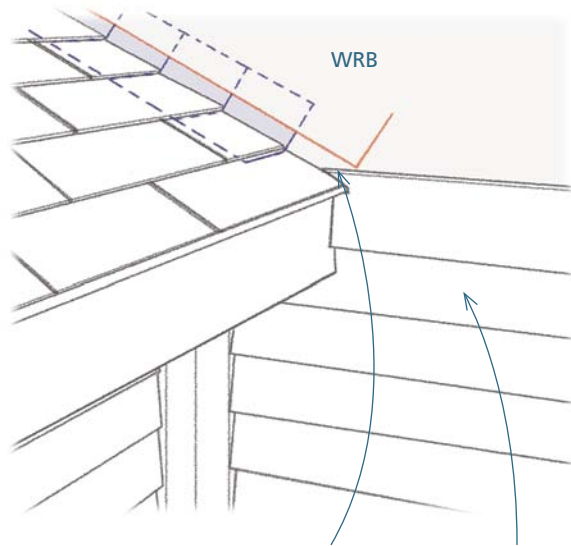

1 After establishing where the bottom of the first course of roof shingles will be, lay out the landing point for the top of the siding 1¼ in. up from that point. Adjust siding courses so that they land at this point.

2 Run the siding up to the line, compressing or expanding courses to land at the target elevation.

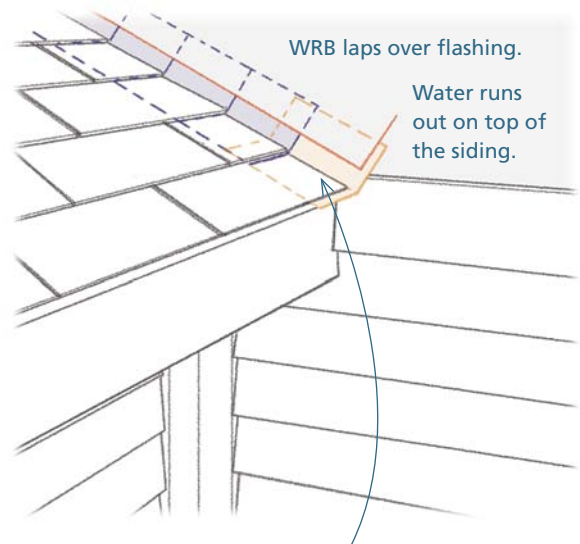

3 Install the flashing over the top piece of siding.

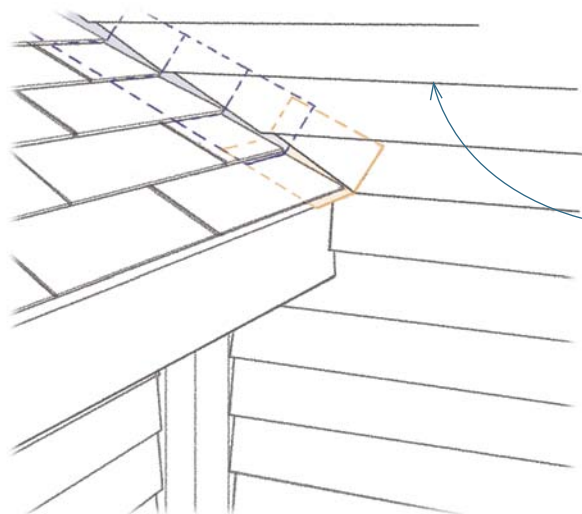

4 Continue the siding. In many cases, getting the siding courses to land at this point will be in conflict with getting the courses to land so that a whole piece of siding runs over the windows. If you must choose between one and the other, get the siding layout to work with the bottom of the step flashing.

• VERTICAL LAPPED SIDING AND PLYWOOD PANEL SIDING

If possible, don't use this type of siding when a wall extends past an eave because flashing here is inherently difficult. If you must use this siding, you can do one of three things.

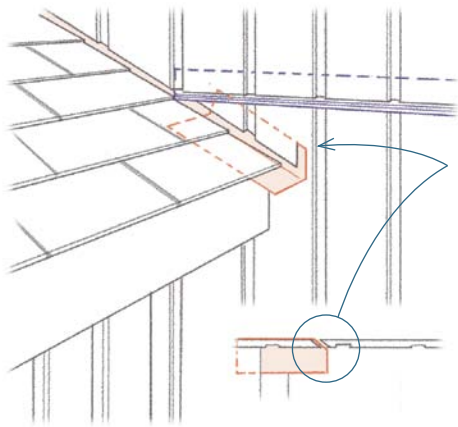

Option 1: Cut an angled kerf in the wood, and bring the flashing out through the kerf.

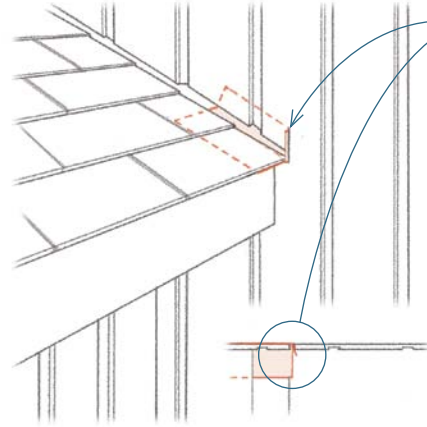

Option 2: Use a piece of "kick-out flashing," and then cut the wood over the flashing.

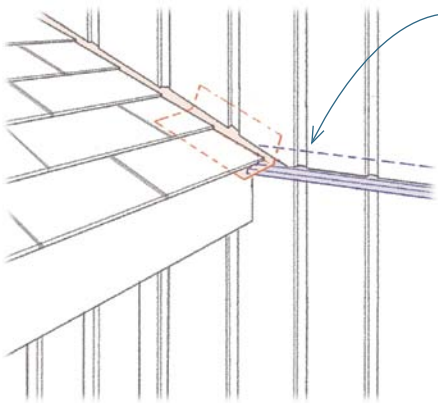

Option 3: Cut the wood so that the joint is just below the bottom edge of the first course of shingles. Install Z-flashing on top of the wood siding. Extend the first piece of step flashing so that it runs over the Z-flashing.

• VINYL SIDING

Vinyl siding also is problematic from this point of view. However, the siding is so porous that water that gets behind it drains out quickly. If you use vinyl, you can do one of three things.

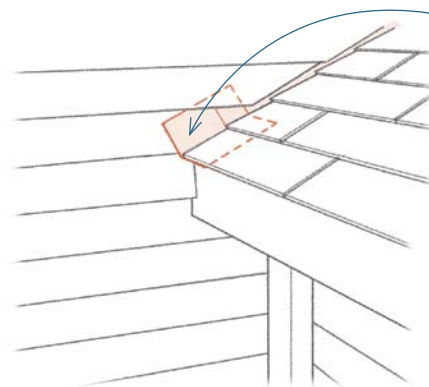

Option 1: Run the bottom piece of flashing in front of the siding. If the metal shows, it can be painted the same color as the siding.

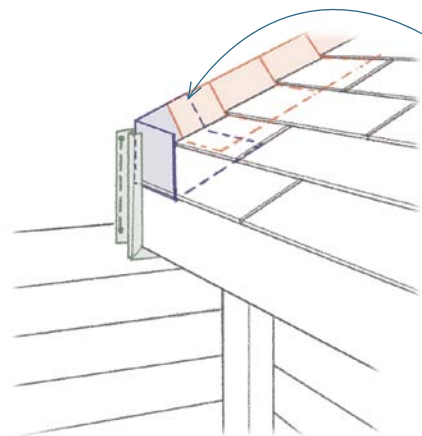

Option 2: Use a piece of kick-out flashing. Cut the J-channel as shown, and then run the siding into the J-channel.

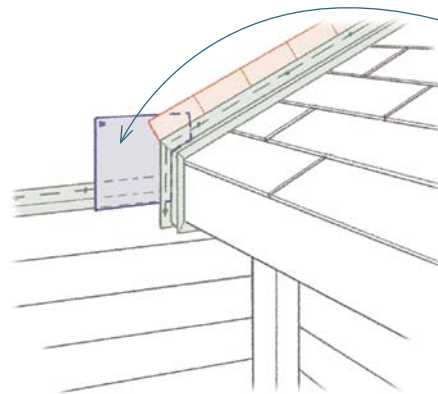

Option 3: Install an aluminum diverter. Make sure the diverter extends down over the top 1 in. of the last piece of siding installed. Place it over the vertical piece of J-channel and behind the step flashing.

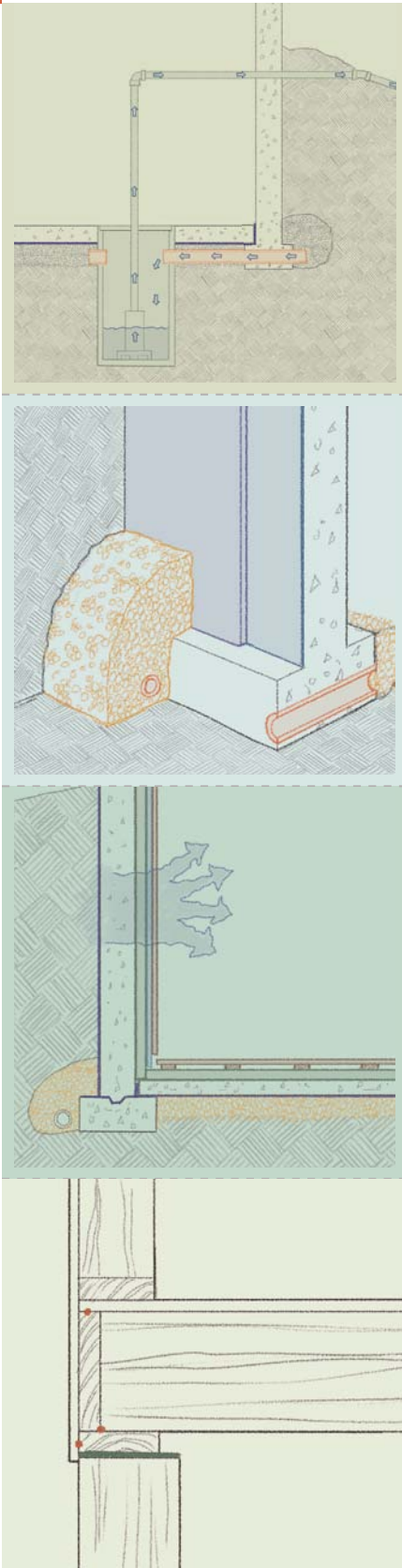

Controlling Moisture in the Ground and in the Air

HOUSES CAN BE THREATENED by two kinds of moisture: water in the ground and water in the air. Unchecked, excessive groundwater may damage the foundation. Moisture in the form of water vapor can nurture rot-producing fungi inside wall and roof assemblies, a risk for both the building and its occupants. It's essential to understand how moisture collects and moves and how it can be controlled.

Controlling water under and around the foundation is a two-part process. The first step is to manage the volume of water that collects under and around the house. This water, which comes in the form of precipitation and from underground sources, must be diverted away from the foundation. The second step is the creation of a barrier against water that remains in the soil. This includes sealing the underside of basement and slab-on-grade floors, damp-proofing the dirt floor of a crawlspace, and waterproofing foundation walls.

● WATER FROM BELOW

Groundwater is a potential threat to the foundation.

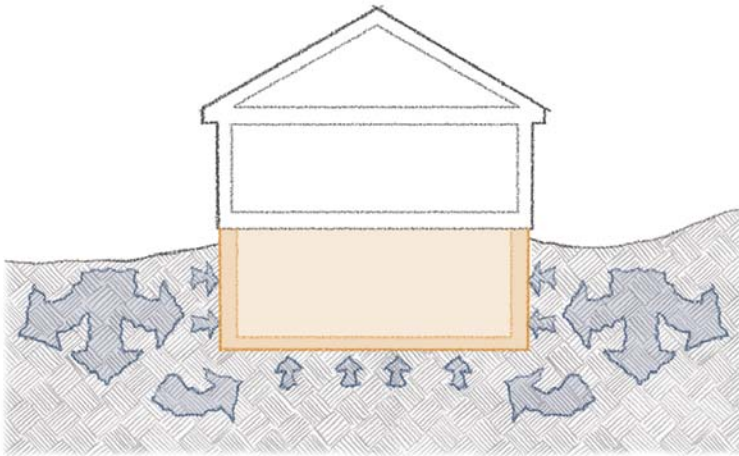

Managing Surface Water

There are two basic ways to manage surface water. The first is to grade the soil and any paved surfaces next to the house so they slope away from the foundation. The second is to collect the water that runs off the roof and direct it safely away.

Grading the Soil around the Foundation

Grading the soil around the foundation is usually one of the last things to be done during construction, but it should be part of the planning from the very beginning, when you lay out the foundation. Most building codes require the top of the foundation to extend at least 8 in. above grade, and the grade should then slope 1 in. per foot for a minimum of 6 ft.

● PLAN FOR AN ADEQUATE SLOPE

When you lay out the foundation, find the highest point 6 ft. from the foundation and add at least 14 in. to establish the lowest permissible elevation for the top of the foundation. A higher foundation gives you the option of increasing the size and slope of the grade away from the house.

A crawlspace foundation typically should be higher so it meets the code-required minimum of 24 in. between the ground and the underside of the floor system.

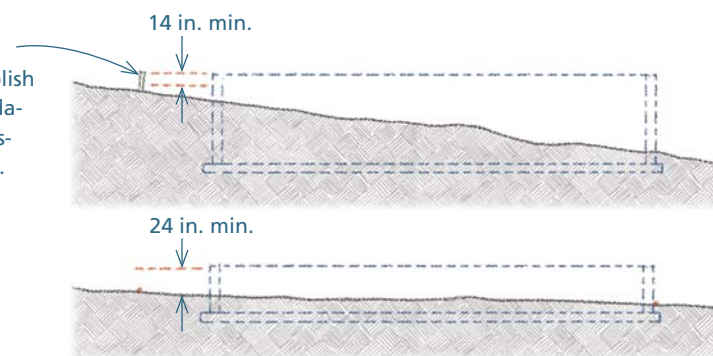

● MARK THE FOUNDATION FOR WATERPROOFING

After the foundation is complete, establish final grade precisely so you know where to end the foundation waterproofing. Mark the grade near the corners, and strike chalklines to mark the final grade on the walls.

On the uphill side of the foundation, drive a stake in the ground 6 ft. from the foundation, leaving at least 6 in. out of the ground. Use a level to transfer the elevation of the top of the stake to the foundation wall.



When the land slopes down and away from the foundation, extend the existing grade up to the foundation.

● SPECIAL GRADING PROBLEMS

Steep lots can be challenging. Even mildly sloping lots can present a problem when, for example, you build an addition.

If you lay out the top of the foundation so it will be high enough on the uphill side of the house, the grade will be correct there.

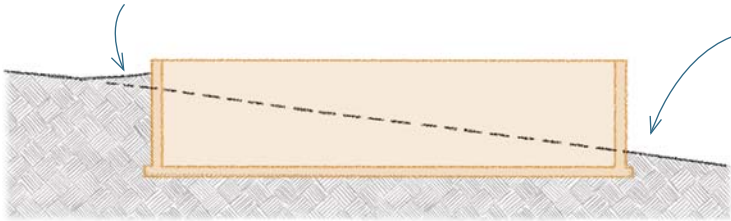

But on the low end, too much foundation will be exposed.

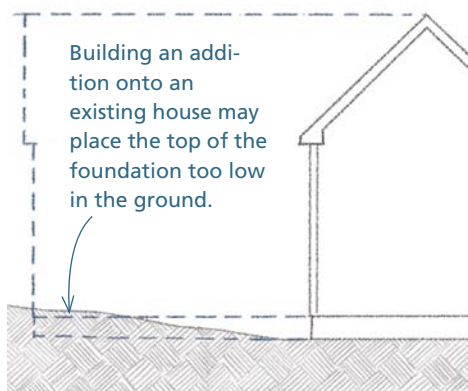

Building an addition onto an existing house may place the top of the foundation too low in the ground.

Resolve these problems by altering the grade near the house. The best solution is to build a retaining wall.

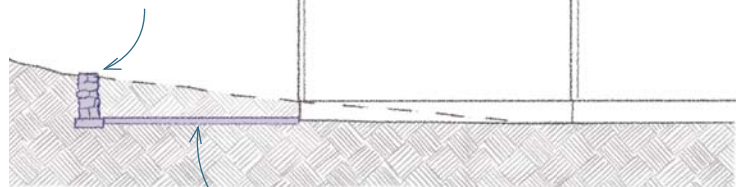

The area between the house and retaining wall can be paved, creating a patio. Make sure the surface slopes away from the house.

Collecting and Draining Rain from the Roof

A small house, with a roof that totals 1,600 sq. ft. in area, sheds more than 1,000 gal. of water for every inch of water that falls on the roof. Keeping this runoff away from the foundation is an essential part of any water-control plan.

The most effective solution is a gutter and downspout system that carries water away from the foundation, as shown below.

Alternatively, insert the downspout into a drain (usually a 4-in.-dia. or 6-in.-dia. PVC pipe) that carries the water farther away from the house. If you go with this option, include a cleanout in the system to make it easier to clear clogs in the future. Never direct the runoff from the roof into the perimeter drains of the foundation.

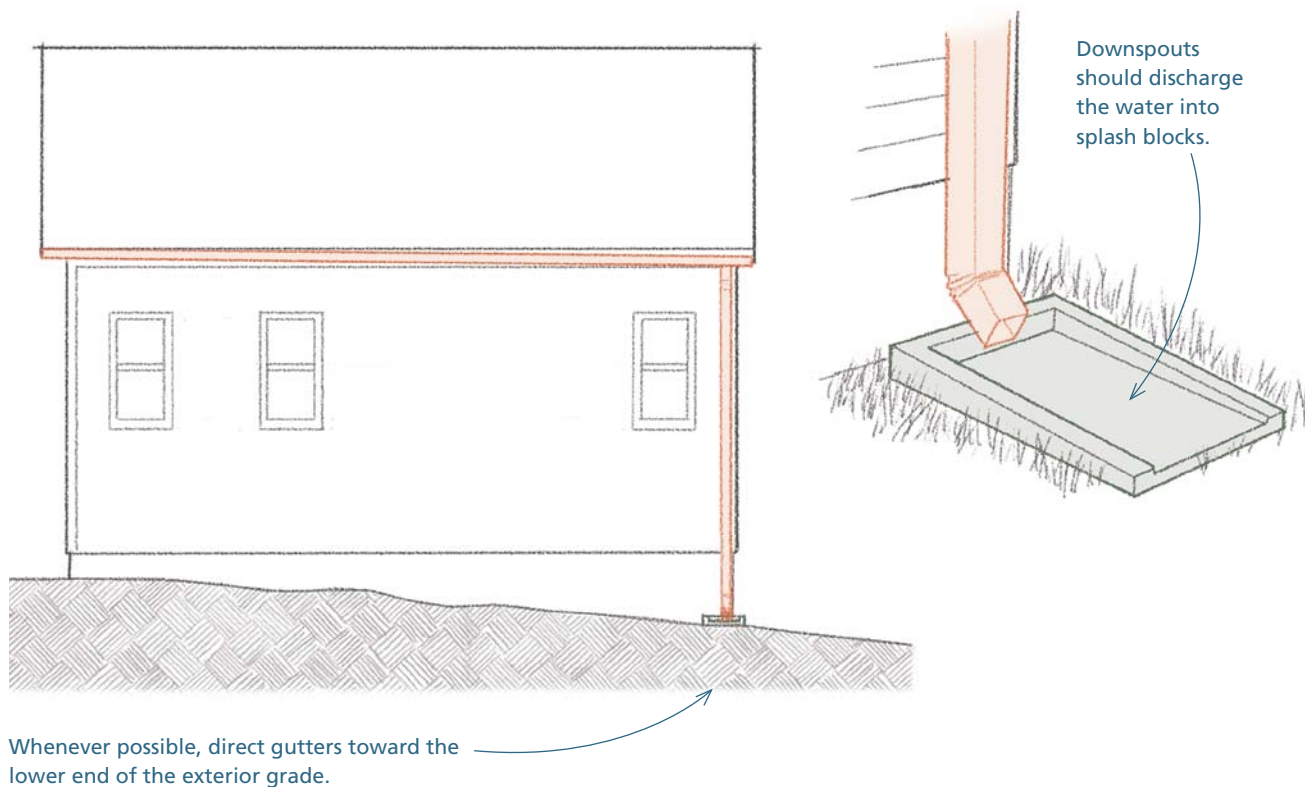

Managing Groundwater

Water in the soil is much less predictable than water aboveground. It can move in any direction, even uphill. It's important to remember, however, that gravity is still your main ally in controlling water under and around the foundation.

Managing Water under a Slab or Basement

Keeping concrete floors dry is a two-part process. The first part is to collect and drain the water under the floor; the second is to install a vapor barrier between the soil and the underside of the slab.

Begin by grading the soil. Use a transit, laser level, or string as a guide as you knock down the high points and fill in the low spots. Compact any loose soil by using a handheld plate compactor or a mechanical compactor.

If the plan calls for a sump crock (also called a sump basin), dig and install it now. The top of the crock should be set even with the top of the planned floor. (For more on the setting of the crock, see "Setting a Sump Crock" on p. 284.)

Once the soil is graded, put down a layer of washed gravel a minimum of 4 in. thick. The stones in the gravel should range from ½ in. to 1 in. in size. Use a transit, laser level, or string as a guide as you install the gravel level and to the correct elevation.

TOP TIP

Movement by Pressure

Water can be transported by pressure. Pressure from water or soil above compresses the water. When it finds a fracture, a seam, or a streak of coarse particles in the soil, this water can move rapidly uphill in the form of a spring. This is like the water that comes out of a garden hose. When you open the tap, the compressed water comes squirting out.

Springs in clay often follow a streak of coarse sand or gravel. Builders imitate this by installing a layer of gravel in the soil, through which the water flows according to the dictates of gravity.

WAYS OF WORKING

How Water Can Move Uphill

Just as a sponge soaks up water on a countertop, water is often drawn up through the pores between particles of the soil via capillary action. In the ground, this effect differs with the size and type of soil particles and the spaces between them. Although it's not always true, capillary action is more pronounced when the particles and the spaces between them are small. Clays have the smallest particles of all types of soils, and water in some clays can rise 30 vertical feet through capillary action. Other types of clay, however, block the passage of water. One of them, called bentonite clay, is actually used as a waterproofing material (see "Damp-Proofing and Waterproofing Materials" on p. 287).

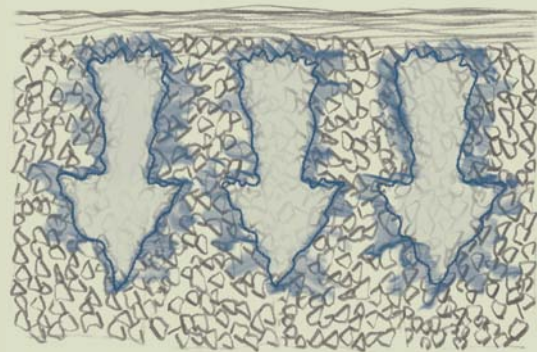

Very coarse soil does not usually support capillary action. Gravity pulls water down through the large spaces between coarse sand and gravel, a process called percolation.

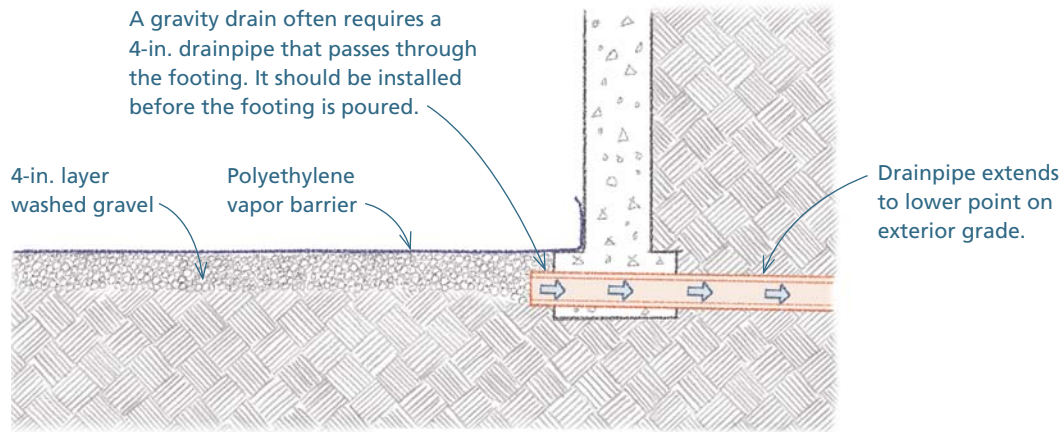

● MANAGING WATER IN A CRAWLSPACE

If a crawlspace will have a dirt floor, the most common design, there are several measures you can take to keep groundwater from collecting.

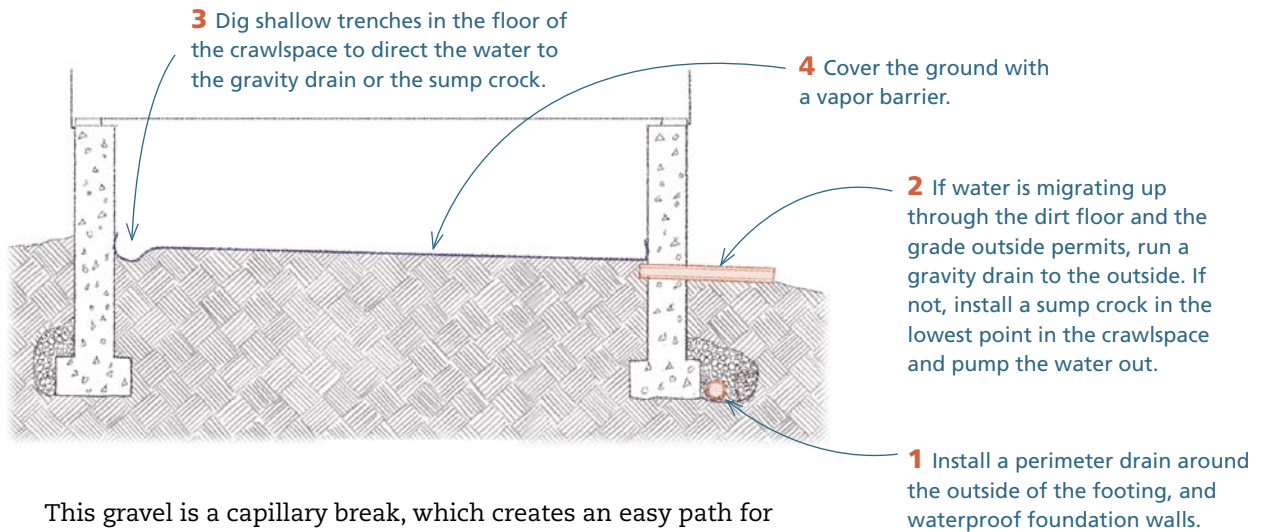

This gravel is a capillary break, which creates an easy path for the water to flow through on its way to either an exterior drain or a sump crock. Ideally, you'll be able to drain the water to a point outside the house that's lower than the soil under the slab. This kind of drain, called a "daylight" or "gravity" drain, doesn't require a sump pump, but it does require forethought.

If there is no point on the building lot that's lower than the soil under the slab, you'll need to install a sump crock.

The final step in managing the water under the floor is to install a layer of polyethylene sheeting on top of the gravel. Typically, 6-mil rolls are used with a 12-in. overlap at any seams. The plastic sheeting retains moisture in the concrete during the pour, which helps it cure properly. After the concrete cures, the polyethylene acts as a vapor barrier and keeps moisture from passing through the concrete.

Setting a Sump Crock

After water in a sump crock reaches a certain height, a sump pump is automatically activated and discharges the water through a drainpipe. Before setting the sump crock, you have to have a plan for collecting the water and discharging it.

First, think about how the sump crock will collect this water. Then, settle on the location, elevation, and exact orientation of the inlets. Also, make sure the sump crock is in a location where the pump will be able to discharge

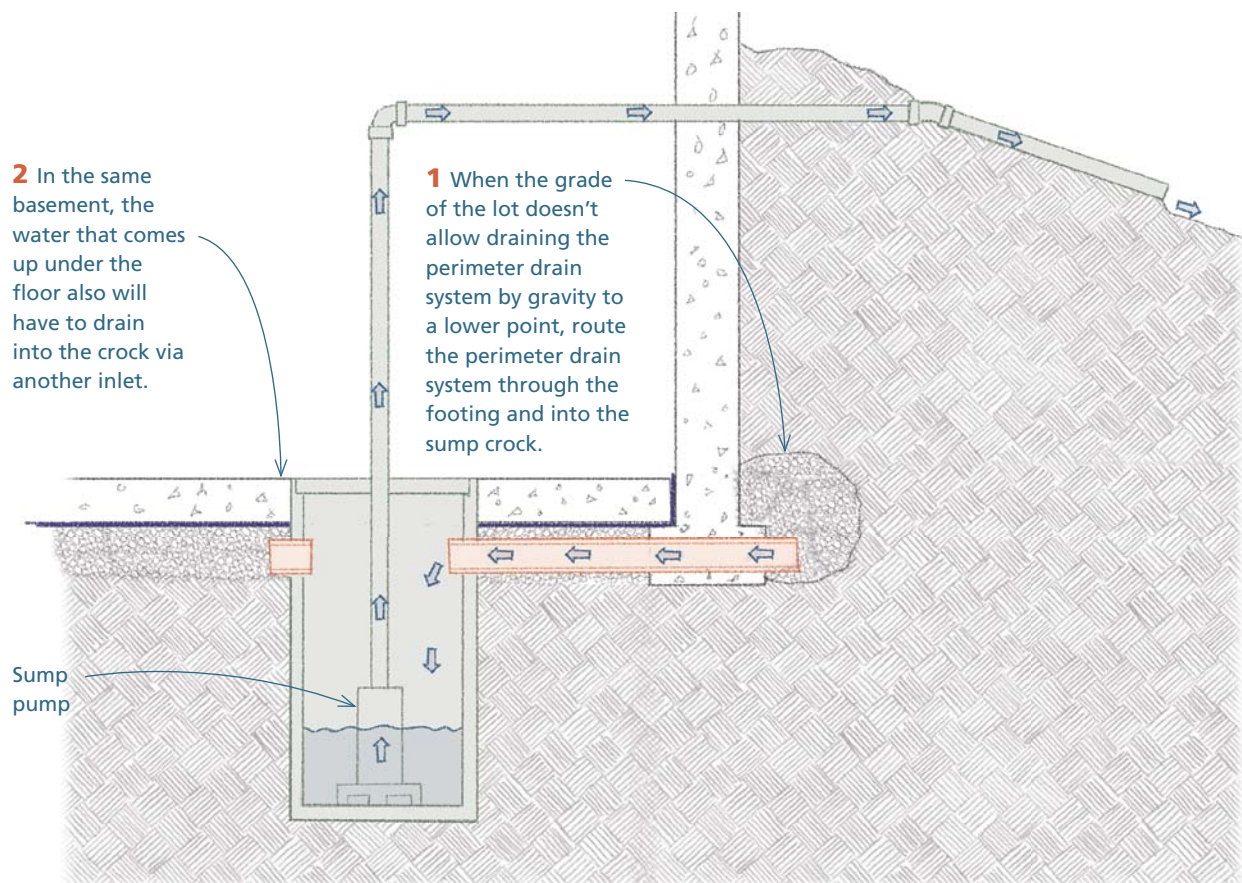

Managing Water around the Outside of the Foundation

Controlling water around a foundation takes a different approach. When you install basement floors, you work from the ground up, beginning with the soil and ending with the concrete slab. When you build a foundation, on the other hand, you work from the walls out.

water via pipes to the outside of the foundation. The water should be deposited several feet away from the foundation on its downhill side. From there, the pumped water will flow away from the house.

If you're building a basement with exterior stairs leading down to a basement door, install a drain in the floor of the stairway, which should also be routed into the sump crock.

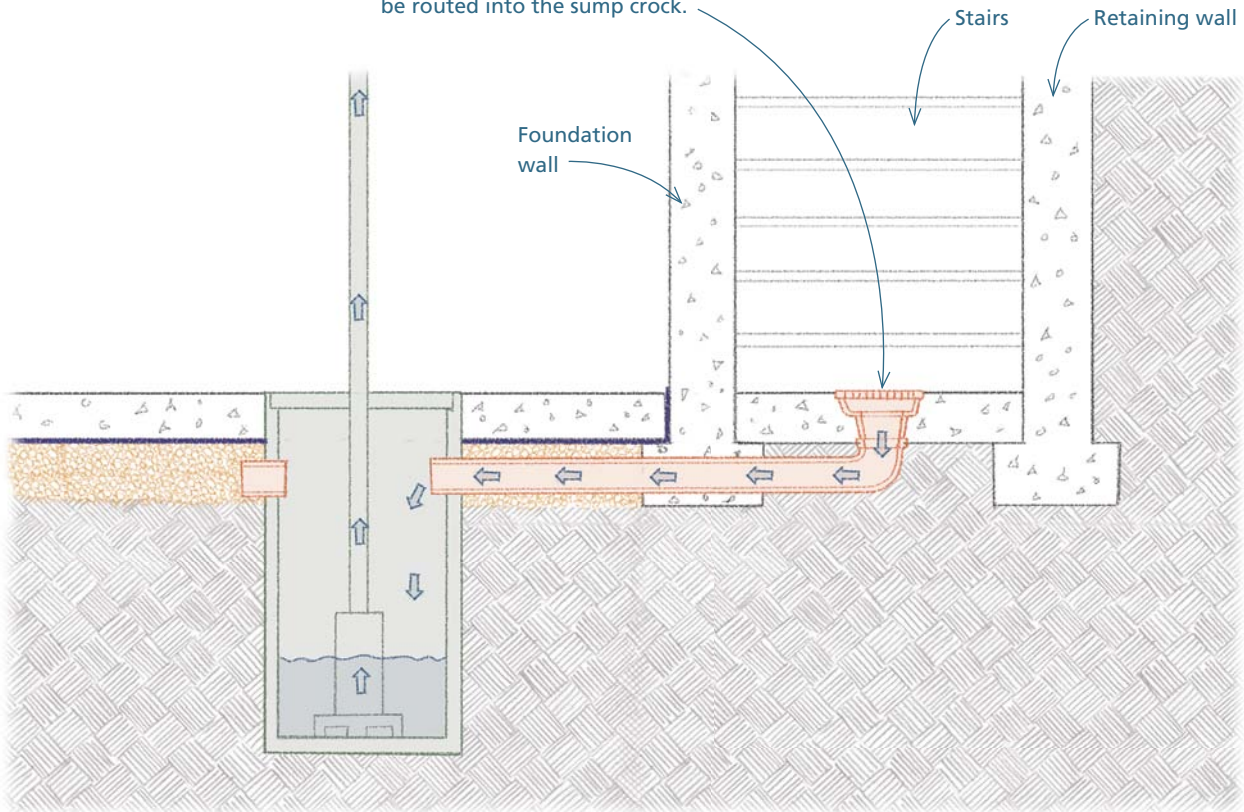

The process begins with building the walls and ends with backfilling around the foundation.

Damp-proofing and waterproofing foundations Most building codes require builders to damp-proof foundations from the top of the footing to the top of the finished grade. In areas where the water table is high, where the surrounding soil is often saturated with water, or where active springs are present, waterproofing is required.

In deciding whether to use standard damp-proofing materials or more expensive waterproofing materials, one of the most important considerations is whether the area in the basement will be used as a living space. If so, waterproofing should be used. The percolation rate of the soil around the foundation is also important. If the soil drains well, a damp-proofing material should be sufficient; if the soil has average or poor percolation rates, waterproofing is a good investment. Keep in mind that the difference in price when the foundation is exposed is small compared to a repair later, after the foundation has been backfilled.

Installing drainage board Soils rich in clay and silt hold water against the foundation walls. In periods of heavy rain, this water increases the possibility of leaks; in frigid weather, water can freeze and expand, damaging the foundation.

Builders use two methods to drain the water in soil next to the foundation. The first is to install drainage board against the foundation, as shown below.

Drainage board usually goes on after the damp-proofing or waterproofing has been applied to the walls and before the perimeter drains are installed.

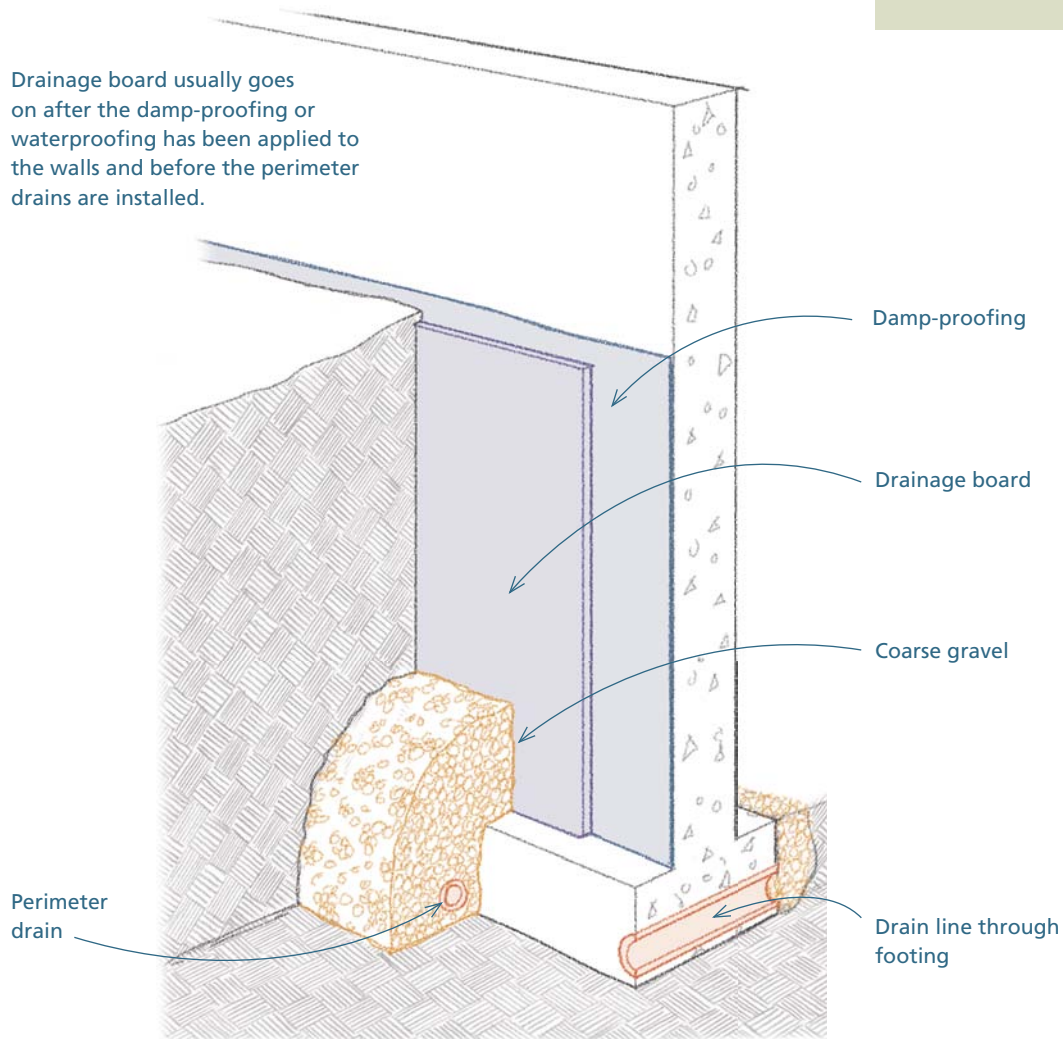

TOP TIP

Damp-Proofing vs. Waterproofing

.....

Damp-proofing is a water-repellent layer that keeps the foundation materials from absorbing water through capillary action. It protects the foundation against flowing and shallow standing water.

Waterproofing is a watertight layer that protects the foundation from deep standing water and water under dynamic pressure.

.....

Damp-Proofing and Waterproofing Materials

A variety of materials can be used for damp-proofing and waterproofing foundations. They can be divided into four main groups:

Cementitious systems

These are modified portland cement products. The most common type for residential work is Super ThoroSeal®, a polymer-modified cement product that comes in dry powder form. It's mixed with water and applied with a trowel or brush. Its two main advantages are that no special tools or skills are required, and it can be applied to surfaces that are not completely dry. The main disadvantage is that it lacks crack-bridging capabilities. If a crack develops, the coating will be breached.

Fluid-applied membranes

Fluid-applied systems are solvent-based or water-based liquids that are sprayed, rolled, or brushed on and dry as a seamless membrane. These materials contain urethanes, rubbers, asphalts or plastics, and other flexible, waterproof solids. The chief advantage of these materials is that they are elastomeric. This means that they can stretch and thus have good crack-bridging properties. The main disadvantage is that they often require special equipment. Some formulations have to be heated and sprayed; others are two-part systems that require special mixing equipment. Also, the concrete or masonry surface must be cured, clean, and dry. This often means delays of several weeks after the foundation is erected.

Sheet membranes

The most common membranes are high-density polyethylene, vulcanized rubber, and PVC. Some of the sheets are hot-applied or are self-adhering (peel-and-stick). Others are mechanically attached. The mechanically attached sheets don't require a cured, dried surface.

With the exception of the hot-applied systems, these materials can be installed without special skills or equipment. Unlike fluid-applied membranes, they have seams, which must be detailed carefully to avoid leaks.

Sheets that are glued to the foundation usually have fair crack-bridging capabilities; those that are not glued have excellent crack-bridging capabilities.

Some of these membranes have dimpled surfaces, which is an asset because the dimples create an effective drainage plane next to the foundation.

Bentonite clay

Bentonite clay expands in the presence of water and in this swollen state blocks the passage of water. It comes in several forms, but the most common for residential work is thin rolls or sheets. These often have a paper or plastic backing to help hold the clay in place during installation. Some are self-adhering and applied like any peel-and-stick membrane.

Bentonite demands little surface preparation and is self-healing. If the foundation cracks, the bentonite will swell and close the crack in the waterproofing layer.

No special tools are necessary for the installation. It should be protected from rain until you backfill. When installed correctly, it's an excellent waterproofing material, but it's not available in many areas.

There are several kinds of drainage boards. One of the most common is a dense fiberglass sheet with most of the fibers oriented vertically. Water follows the fibers down to the perimeter drain at the bottom of the foundation. These drainage boards also protect the waterproofing during backfilling, and they provide thermal insulation. One brand is Warm-N-Dri®.

Another type is a semirigid sheet of high-density polyethylene with dimples on one or both sides, which works as both a water-

proofing sheet and a drainage layer. Water runs down the spaces between the dimples to the perimeter drain at the bottom of the foundation. Delta®-MS is one brand.

Builders also may use drainable soil for the backfill. It can be used in combination with drainage board to maximize drainage.

Installing perimeter drains Perimeter drains are usually installed around the outside of the footing and either gravity-drained to a lower point on the lot or directed to a sump crock. In some cases, especially when retrofitted into an existing house, perimeter drains are installed along the inside of the footing. Some builders play it safe by installing perimeter drains on both sides of the footing.

● INSTALLING A PERIMETER DRAIN

1 Lay a strip of filter fabric about 6 ft. wide on the soil next to the footing. Fold one edge up the footing and the other up the side of the excavation.

2 Place about 2 in. of gravel on the filter fabric, then install the drainpipe around the footing. Make sure the drainpipe is level or graded slightly down toward the outlet. Use either flexible corrugated drainpipes with slots or rigid PVC drainpipes with holes (holes in rigid pipe should face down). Direct the perforated drainpipe into a solid drainpipe that leads to daylight at a point that's lower than the bottom of the footing, or direct the drainpipe into a sump crock inside the foundation.

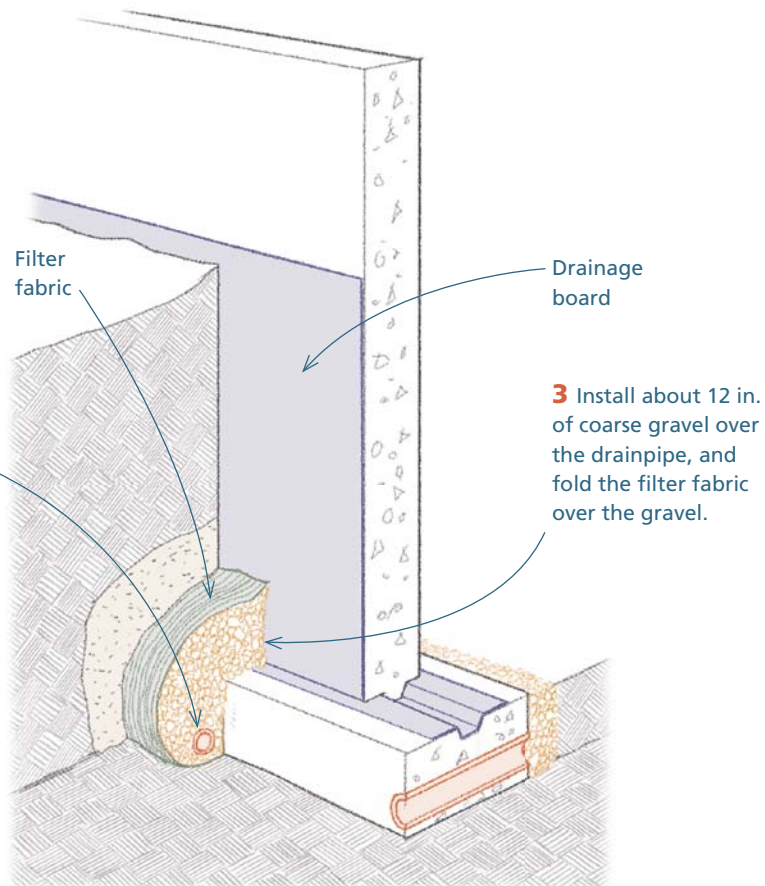

• BACKFILLING THE EXCAVATION

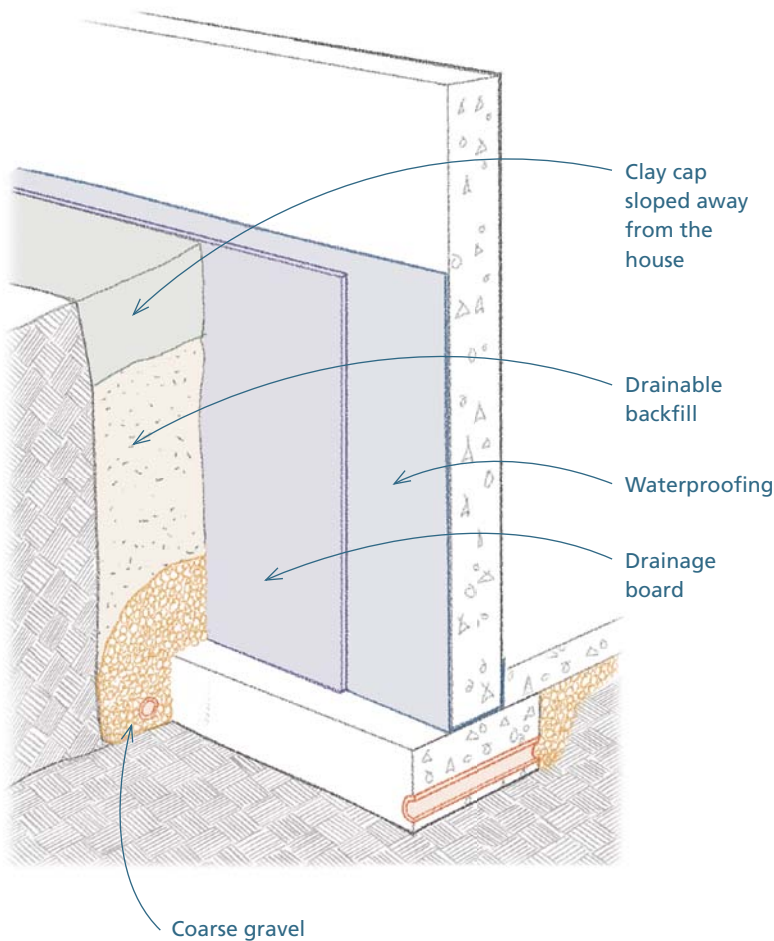

Backfilling the excavation If the soil from the excavation is clay or silt, both of which hold water, it makes sense to truck in coarse sand for the backfill. This material allows water to percolate quickly to the perimeter drain.

If the backfill area is very wide, the cost of the sand can add up quickly. In these cases, the excavation contractor should be able to drop the sand next to the foundation and fill the rest of the space with material from the excavation.

Drainable soil removed during the excavation can be used for backfill. If it contains large or jagged stones, however, place a layer of sand next to the foundation to avoid damaging the waterproofing layer or the foundation itself.

Clay prevents the rapid absorption of surface water into the soil. If you have clay on site, use it for the final layer of the backfill. Make sure you grade this final layer, sometimes called a clay cap, away from the foundation so the water on the surface runs away from the house.

Controlling the Water in the Air

In the first half of the 20th century, wall, floor, and ceiling assemblies were porous, allowing large amounts of air to pass freely in and out. Assemblies stayed dry because air could get out as quickly as it got in. In this relatively dry environment, organisms that cause rot and mold were not able to thrive. The idea of a “climate-controlled” interior had not yet taken hold.

Since the 1960s, houses have gotten bigger, and people have come to expect central heat and air-conditioning. At the same time, the cost of energy has gone up. This combination has put a premium on energy efficiency, and this means less porous building assemblies. The risk is that tighter assemblies will trap moisture, promoting mold and rot.

The challenge for builders—one of the most vexatious in residential building—is to keep as much moisture vapor out of the frame as possible while providing some mechanism to allow moisture that does get in to escape.

Concrete, masonry, lumber, drywall joint compound, paint, and other materials often hold a lot of water when new and they often get wet during construction. For this reason alone, it’s important to provide some means for building assemblies to dry, a process that can take a year or more. After that, the object is to keep the rate that moisture enters building assemblies roughly even with or slightly below the rate that moisture exits. The ultimate goal is to keep the assemblies balanced at a humidity level that’s too dry to support rot-producing fungi and mold.

Air Transport and Vapor Diffusion

Vapor migrates into building assemblies via air transport and vapor diffusion, which are different mechanisms.

Air transport of vapor Air that moves into an assembly because of pressure differentials brings vapor with it. There are two ways to slow down this movement of air even though it can never be totally stopped.

First, install an airflow retarder. This can be made from a variety of materials and can be installed on the inside, outside, or within the thickness of the assembly. It should be as continuous and as free from openings as possible. A leak in an airflow retarder can carry large amounts of vapor inside wall and roof assemblies. Airflow retarders need not be impermeable to the passage of vapor. When detailed correctly, gypsum drywall, for example, can be an effective airflow retarder—even though it is a highly permeable material.

TOP TIP

Three Things to Know about Air

.....
To keep air from depositing moisture in building assemblies, it’s important to understand how it collects, moves, and releases moisture. Here are some of the basics:

Air rises when heated. This is the basic principle at work in hot-air balloons. Heated air is lighter than surrounding air, so it rises.

Warm air holds more moisture than cool air. When the air is 90°F (32°C), it holds about six times as much moisture as air that’s just above freezing. When warm, moisture-laden air comes into contact with a cool surface, it releases the water in the form of frost or drops of water.

Air moves from areas of high pressure to areas of low pressure. This is what happens when you pull the trigger on a nail gun. Air that has been mechanically compressed rushes out of the tank, through the hose, and out the end of the nail gun. The air in the high-pressure area (the tank) has moved with great force to an area of low pressure (the air outside).
.....

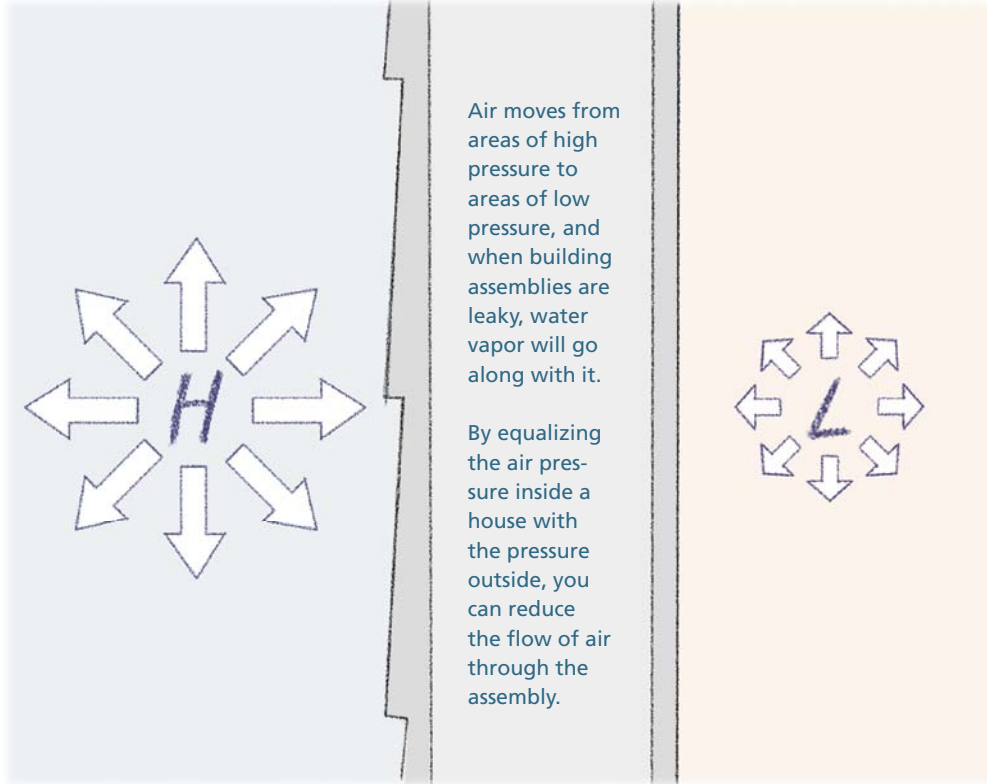

The second way to slow down the movement of air is to equalize air pressure on both sides of the enclosure. Since you can't do anything about the air pressure outside, this process is restricted to adjusting the air pressure inside the house, a task typically left to qualified HVAC contractors.

Vapor diffusion Vapor diffusion is the movement of water vapor through building materials. Vapor moves from areas of higher pressure to areas of lower pressure, from the warm side of an assembly to the cool side. To reduce vapor diffusion, builders install a vapor-diffusion retarder, such as the kraft paper facing on batt insulation, on the side of the enclosure that is warmest for most of the year. Although once cutting edge, the use of polyethylene sheeting is no longer considered good building practice in most climate zones.

Vapor Diffusion Essentials

Vapor-diffusion retarders (VDRs) are unlike airflow retarders in several ways.

- They are effective even if they have some openings or aren't continuous. If a VDR covers 90% of a wall surface, it will impede water vapor diffusion over 90% of the wall.
- The degree of permeability is an essential factor. VDRs are made from relatively impermeable materials. Building materials such as gypsum drywall cannot be used as VDRs.
- VDRs are not nearly as important in controlling vapor movement as airflow retarders. If you do a thorough job of preventing the movement of air into building assemblies, chances are good you won't have a problem with excessive moisture.

TOP TIP

Strictly Speaking

Permeability is the rate at which water vapor passes through a material. Materials that impede the passage of water vapor are considered impermeable. Materials that permit vapor to pass through are permeable.

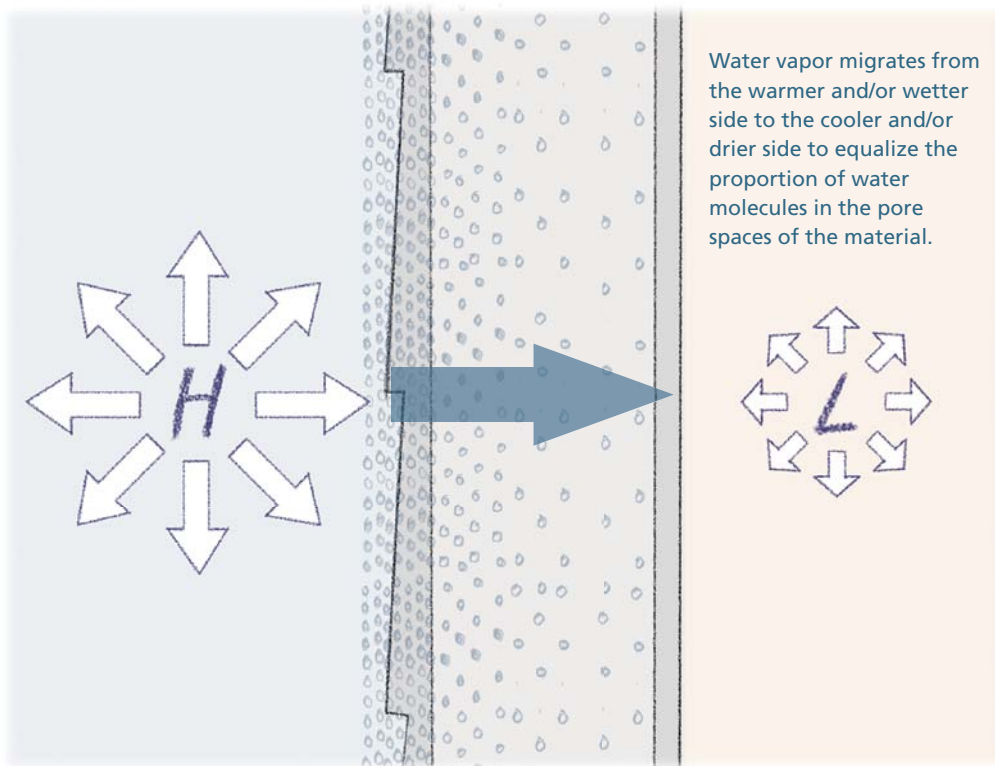

Controlling Vapor and Capillary Action in Foundations and Basements

Concrete is laden with moisture when it's first poured. A concrete foundation may require 1,000 gal. of mixing water, and much of it remains in the concrete long after the surface is dry. Concrete also wicks up moisture from the ground through capillary action and admits water by vapor diffusion.

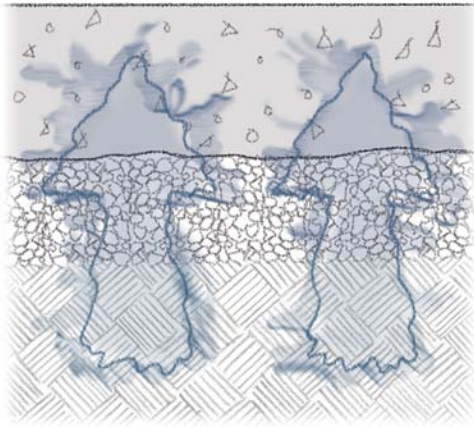

Installing vapor barriers and capillary breaks is the key to keeping moisture out of foundations and basement floors.

TOP TIP

Retarder vs. Barrier

Because vapor can pass through all materials, building scientists prefer the more accurate term “vapor-diffusion retarder” over “vapor barrier.” Polyethylene sheeting and other highly impermeable materials, however, have such an extremely low permeability rating that they are routinely referred to as vapor barriers.

● SLAB-ON-GRADE FOUNDATIONS

1 Before pouring the slab, place at least 4 in. of washed gravel under the floor area as a capillary break. Install a drainpipe to daylight (gravity drain) or to a sump crock.

2 After forming the perimeter of the foundation, install a vapor retarder (usually a sheet of 6-mil polyethylene) under both the floor and the integral footing to prevent moisture in the gravel layer from condensing on the underside of the floor. In the footing area, it prevents water from wicking up into the concrete.

4 Before installing the bottom plates of the exterior wall, install both a vapor barrier and a sill gasket. The vapor barrier, which can be a brushed-on waterproofing material or a polyethylene sheet, keeps moisture from wicking up from the foundation into the wall plate. The sill gasket keeps air from infiltrating the seam between the wall plate and the top of the foundation. Sill gaskets, such as FoamSealR™, come in rolls.

3 After stripping the forms, waterproof the outside edge of the slab and install a drain system. In cold areas, you may opt to install rigid insulation at the perimeter before installing the drain.

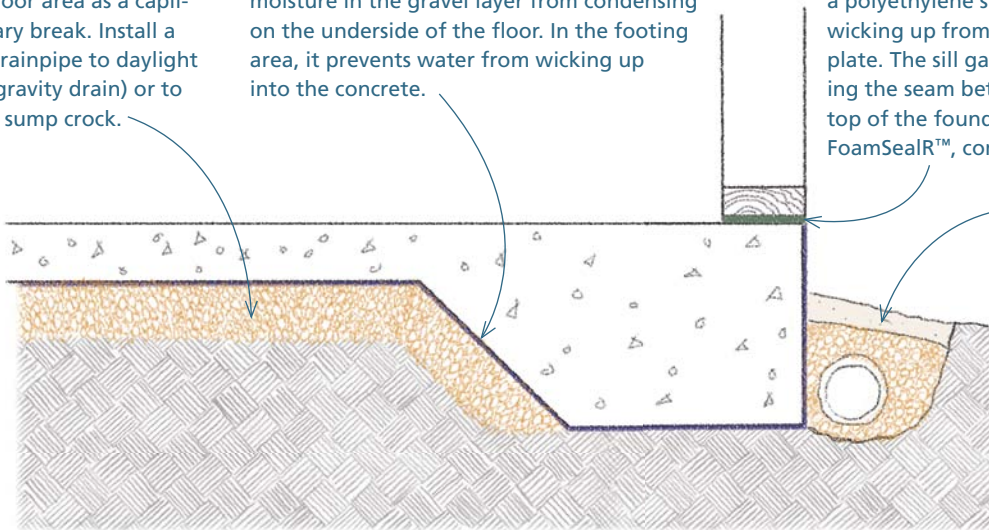

Vapor barriers and capillary breaks for crawlspace foundations Crawlspace foundations can be vented or unvented. Vented crawlspaces are the traditional design, accepted by almost all building codes. Unvented crawlspaces are relatively new and not universally accepted by code.

Drying strategies for basements With the waterproofing on the outside, the mixing water in the foundation wall will dry to the interior. With the polyethylene under the concrete floor, the mixing water in the slab will also dry to the inside. Because the initial drying of these materials takes months, it's prudent to wait as long as possible before finishing the basement. In the meantime, use dehumidifiers and ventilation to remove the moisture as it dries to the inside of the basement.

TOP TIP

Hold Off on Floor Coverings

.....
 With a vapor barrier under and around the sides of the slab, the moisture placed in the concrete during the pour can only exit through the top surface of the floor. Once the floor is under cover, allow the concrete to dry thoroughly before installing floor covering. Avoid floor coverings that trap moisture, such as vinyl.

● **VENTED CRAWLSPACES**

Vented crawlspace foundations treat the area under the first floor of the house the same as any covered exterior space.

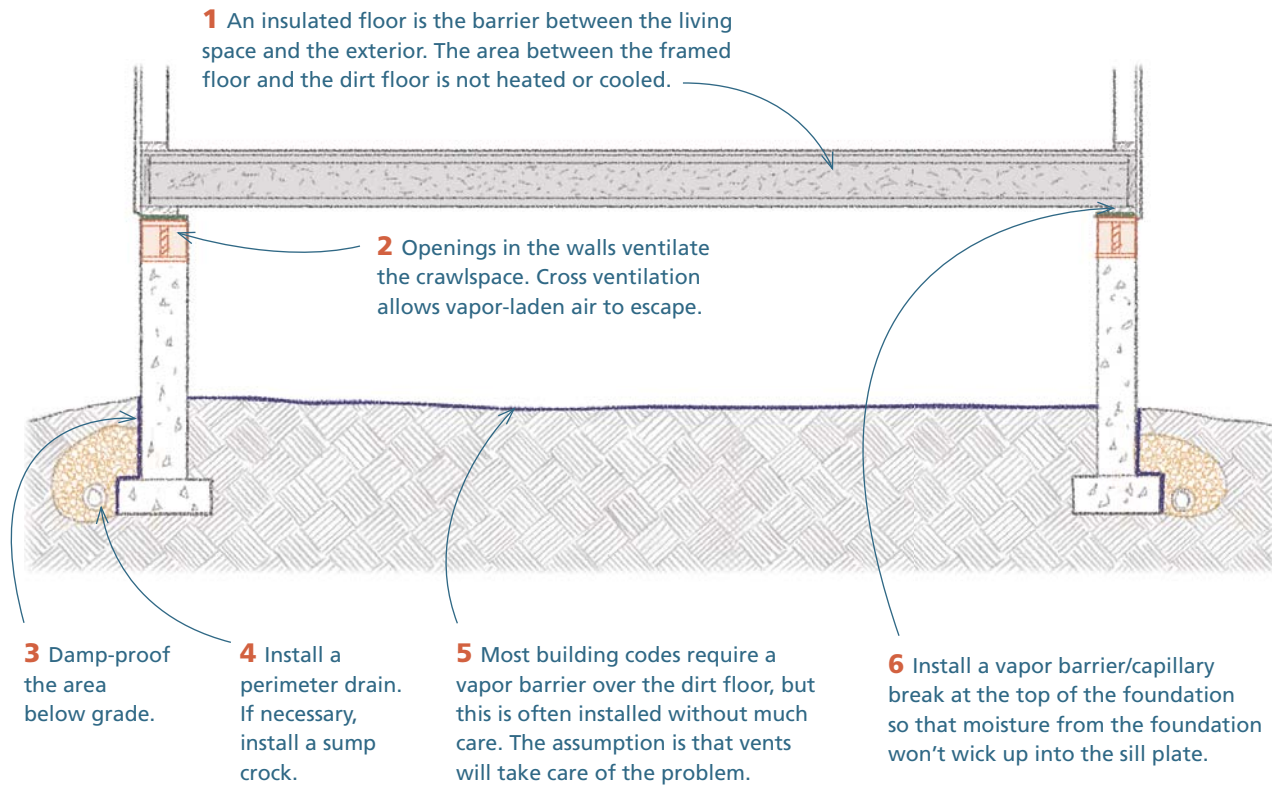

● UNVENTED CRAWLSPACES

Unvented crawlspaces are treated as part of the building enclosure. The walls of the foundation, which don't have any vents, are insulated and the crawlspace is heated in the winter. The thinking is that vents can bring more moisture into the crawlspace than they carry away. In hot, humid weather, warm moisture-laden air enters a cool crawlspace and condenses, leaving water behind. Unvented crawlspaces must be detailed carefully.

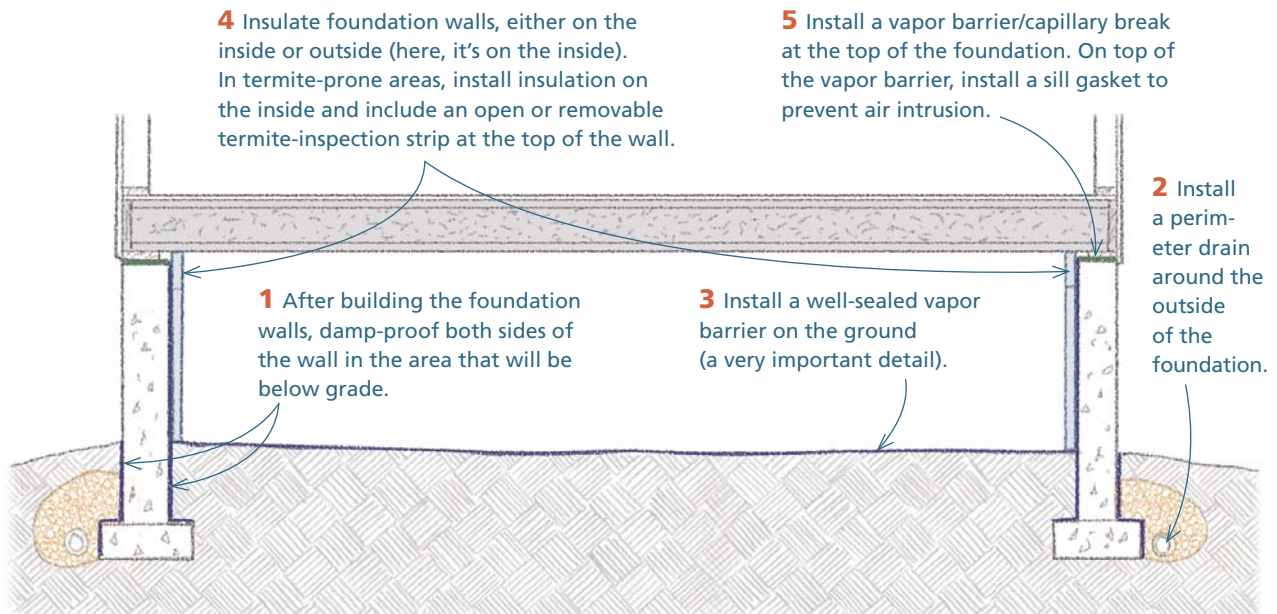

● VAPOR BARRIERS AND CAPILLARY BREAKS FOR BASEMENTS

Because masonry and concrete support capillarity, it's important to install barriers and breaks at key points.

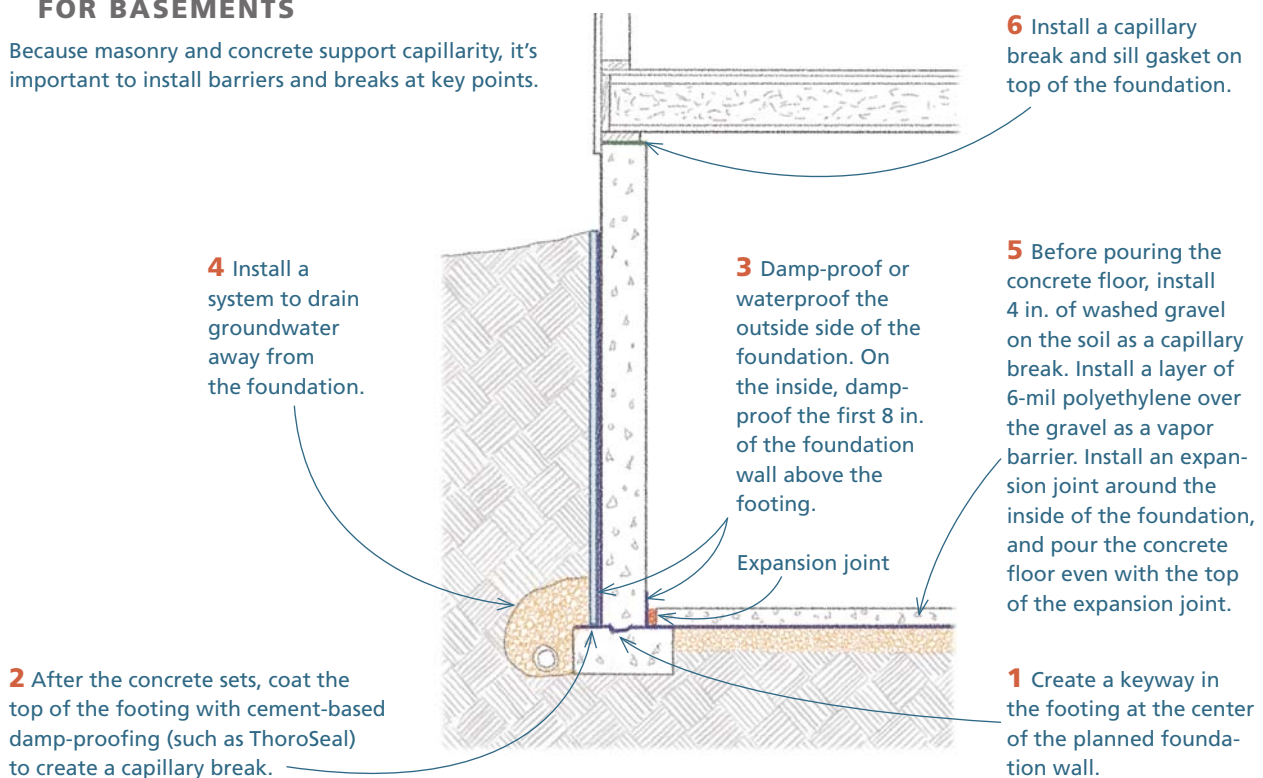

● USING RIGID-FOAM BOARD

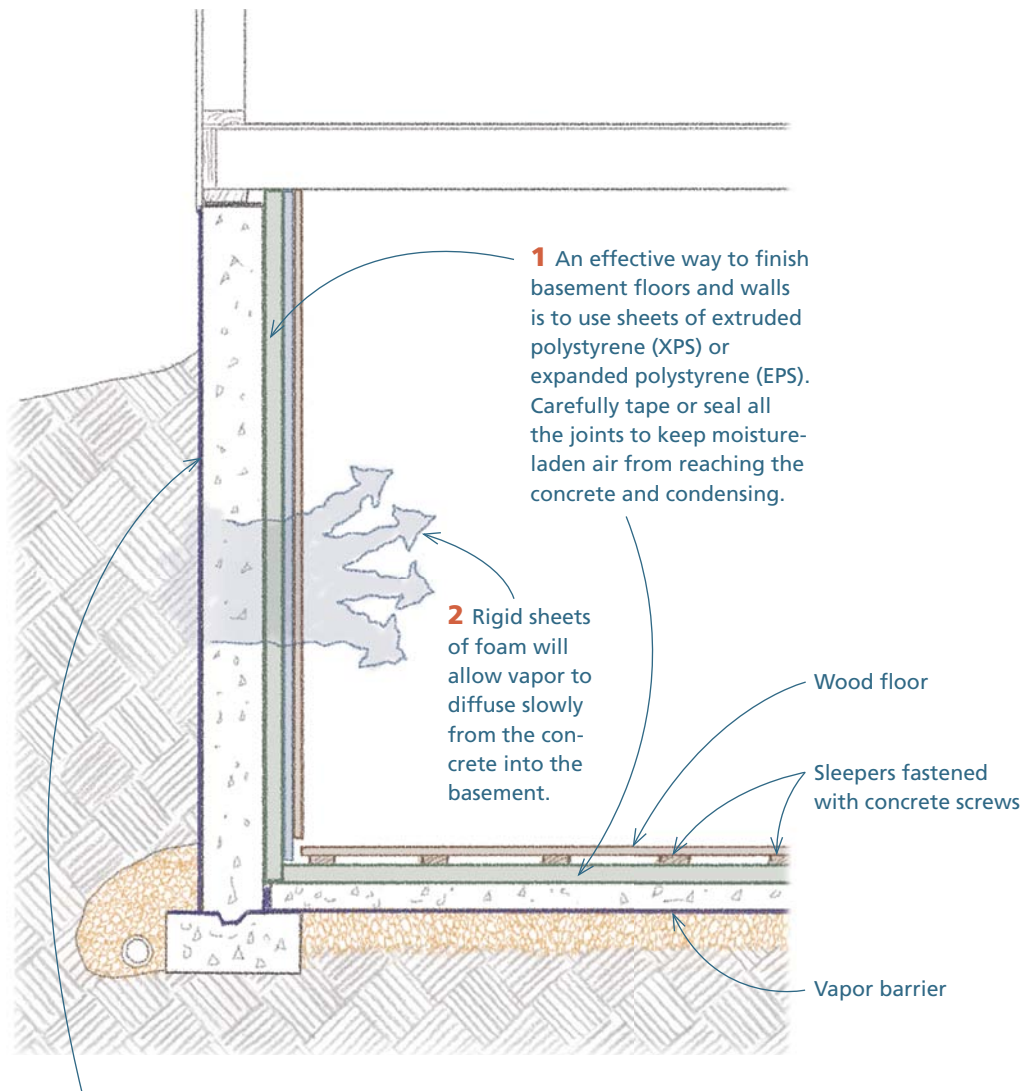

3 The foam has a low perm rate, but it's much higher than the waterproofing membrane on the outside of the foundation. Moisture in the concrete will slowly escape to the inside through vapor diffusion, where it will be gradually eliminated by HVAC equipment.

When you decide to finish the basement, build assemblies that allow the concrete to continue to dry to the inside. Interior insulation assemblies and finishes should be as airtight as possible. In the winter, the heated air in the finished basement will be high in moisture content, and this air should not be allowed to penetrate the finished floor and walls, where moisture can condense on the concrete. At the same time, the finished floor and wall assemblies should be vapor permeable so the concrete can dry.

Assemblies for finishing basement floors and walls

Basement floor covering should be vapor permeable to allow moisture in the concrete to escape. One approach is to install sleepers over a 1-in.- to 2-in.-thick layer of expanded polystyrene (EPS). Use concrete screws (such as Tapcon screws) long enough to extend through the rigid foam and penetrate the concrete. Next, attach a wood floor to the sleepers. Don't install a vapor barrier between the sleepers and the wood floor; doing so would trap vapor that has diffused through the insulation.

The wall finishing assembly can be designed essentially like the floor assembly. Attach sleepers using concrete screws over a layer of EPS, then attach drywall to the sleepers. Just as when installing flooring, don't install a vapor barrier between the drywall and the sleepers.

Controlling Vapor in Wood-Framed Assemblies

Airflow retarders and vapor-diffusion retarders limit the amount of vapor that enters and passes through building assemblies, protecting them from moisture and condensation. The optimal location for these materials varies according to the climate, so it's essential to know what climatic zone you're building in and what works best in that area.

An important component of these systems is insulation. Although most people see insulation mainly in terms of comfort and energy savings, it also plays a major role in the durability of the house. By raising the temperature of floors, walls, and ceilings, insulation prevents water vapor from condensing inside them.

• EIGHT CLIMATE ZONES

There are many ways to classify climatic zones, but building scientists have reduced this list to eight broad categories. Climate zone 8, the subarctic U.S. climate zone, is found only in Alaska. It is not shown on this map.

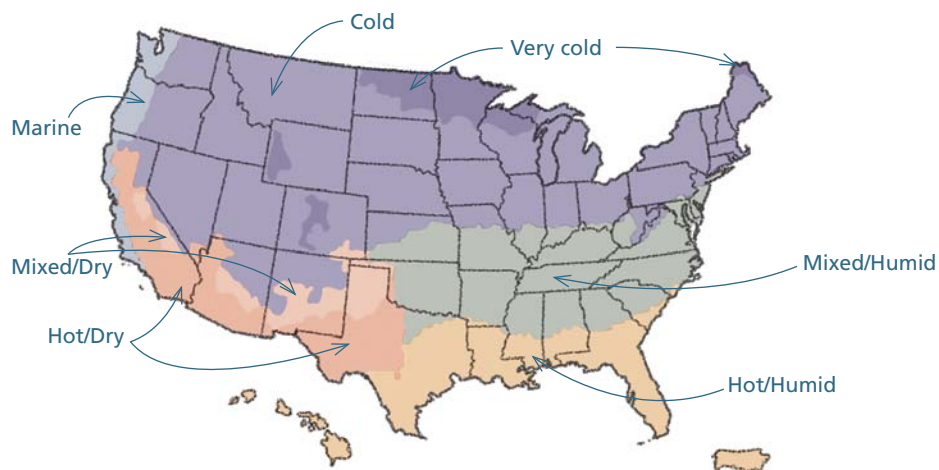

Vapor Permeability of Different Building Materials

The vapor permeability of a building material describes the rate at which it allows water molecules to pass through by vapor diffusion. Permeability is measured in “perms.” The lower the perm rating, the less vapor will go through the material. A material is considered a vapor barrier if it has a perm rating of 1 or less. To avoid trapping moisture in an assembly, the perm rating of the material on the cold side should be at least five times the perm rating of the material on the warm side.

Common building materials can be separated into four general classes:

VAPOR IMPERMEABLE (LESS THAN 0.01 PERM)

- Rubber membranes
- Polyethylene film
- Glass
- Sheet metal
- Foil-faced sheathings
- Vinyl floor covering

VAPOR SEMI-IMPERMEABLE (GREATER THAN 0.01 PERM AND LESS THAN 1 PERM)

- Oil-based paints
- Vinyl wall coverings
- Unfaced XPS more than 1 in. thick
- Traditional hard-coat stucco installed over building felt

VAPOR SEMIPERMEABLE (GREATER THAN 1 PERM AND LESS THAN 10 PERMS)

- Plywood
- OSB
- Unfaced EPS
- Unfaced XPS 1 in. or less in thickness
- #30 tar paper
- Unfaced polyisocyanurate sheathing
- Latex paint
- Low water-to-cement ratio concrete

VAPOR PERMEABLE (GREATER THAN 10 PERMS)

- Unpainted gypsum board or plaster
- Unfaced fiberglass insulation
- Cellulose insulation
- Unpainted synthetic stucco
- #15 tar paper
- Asphalt-impregnated fiberboard sheathing
- Housewraps

Controlling Vapor in Framed Floor Systems

Framed floors are vulnerable to vapor infiltration from below and at the perimeter. There are three basic ways to control the vapor:

- Limit the moisture coming up toward the floor system.
- Install a capillary break between the foundation and the sill.
- Seal the perimeter of the floor system from air infiltration.

Methods for limiting moisture at the source and installing capillary breaks have already been discussed in “Managing Groundwater”

● SEAL THE PERIMETER OF THE FLOOR SYSTEM FROM AIR INFILTRATION

To seal the floor system, do the following as you frame the floor.

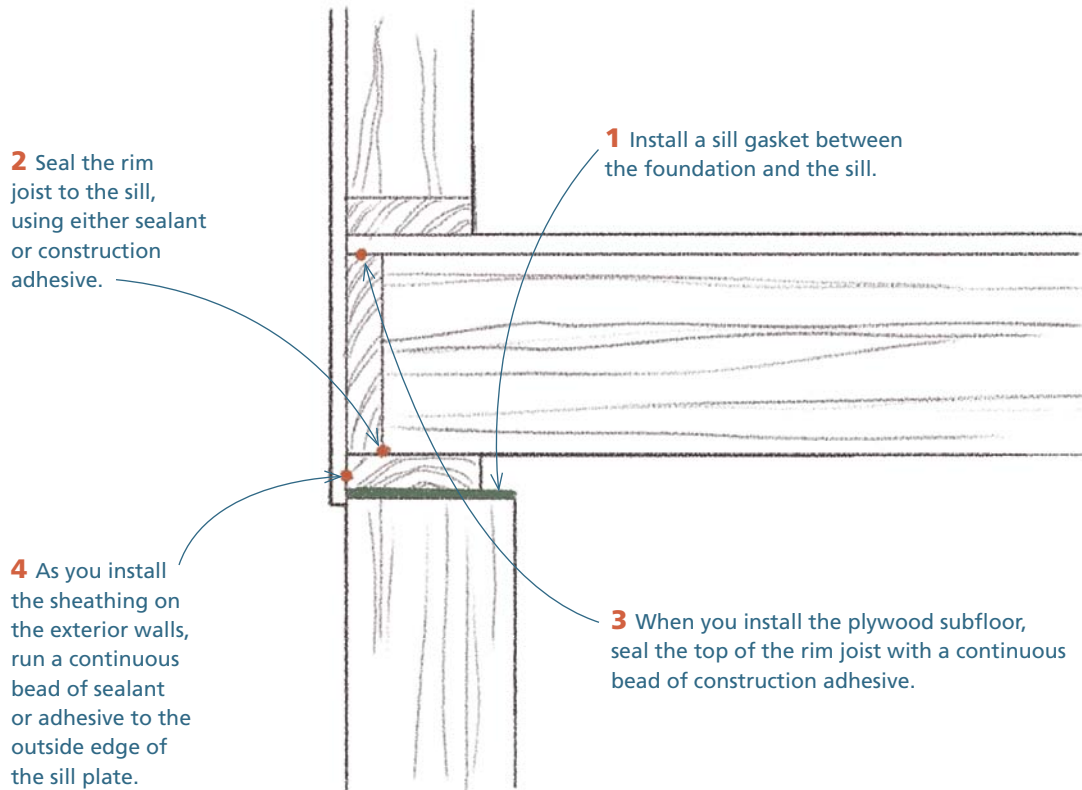

on p. 282 and “Controlling Vapor and Capillary Action in Foundations and Basements” on p. 293. To seal the perimeter of the floor system, see the drawing above.

Controlling Vapor in Framed Walls

To limit vapor intrusion and avoid condensation within wall assemblies, pick a strategy that fits your climate zone. The following examples are chosen to show how to approach these different conditions using various materials. However, it is important to note that the assemblies shown here are not the only options. The range of available materials is large, and the ways in which these materials can be combined into wall assemblies is almost endless. The object of this section is not to recommend a specific wall assembly; it is, rather, to show how to develop sound strategies for designing one.

● WALLS FOR COLD AND VERY COLD AREAS

In the winter, warm, moist air wants to move through the walls toward colder and drier air outside. To add to this outward drive, the inside of the house is often pressurized by blowers in the heating system. After taking the following steps, also check with an HVAC contractor about balancing air pressure inside the house with that outside.

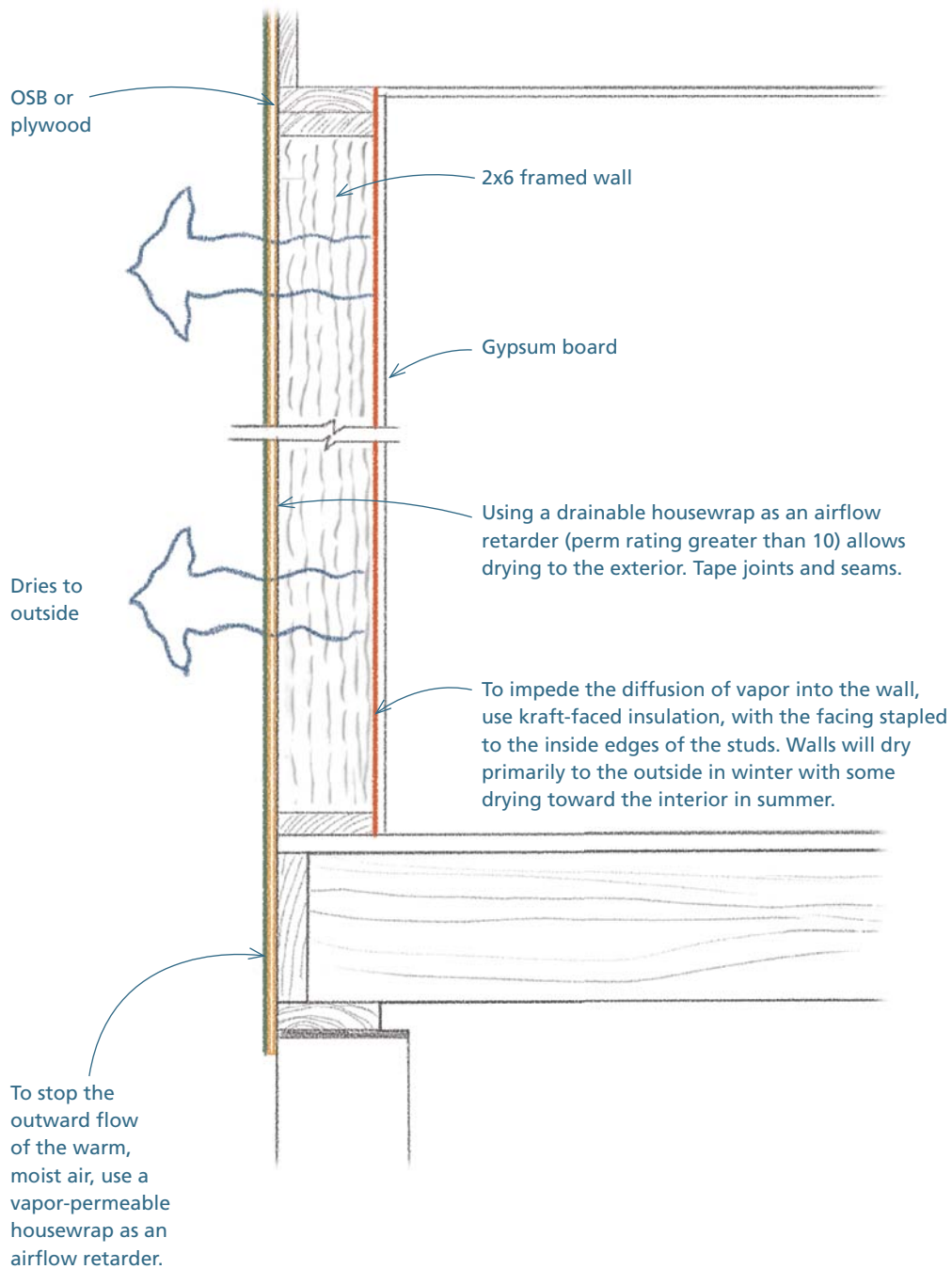

● WALLS FOR MIXED/HUMID AREAS

At cooler times of year, when the house is heated, inside air is warm and moist and the movement of moisture and air is from inside to outside. In hot weather, it's the opposite. In these assemblies, a vapor-diffusion barrier is not a good idea. In this climate zone, both sides of walls should be allowed to dry. Check with an HVAC contractor about balancing the air pressure on the inside with that on the outside.

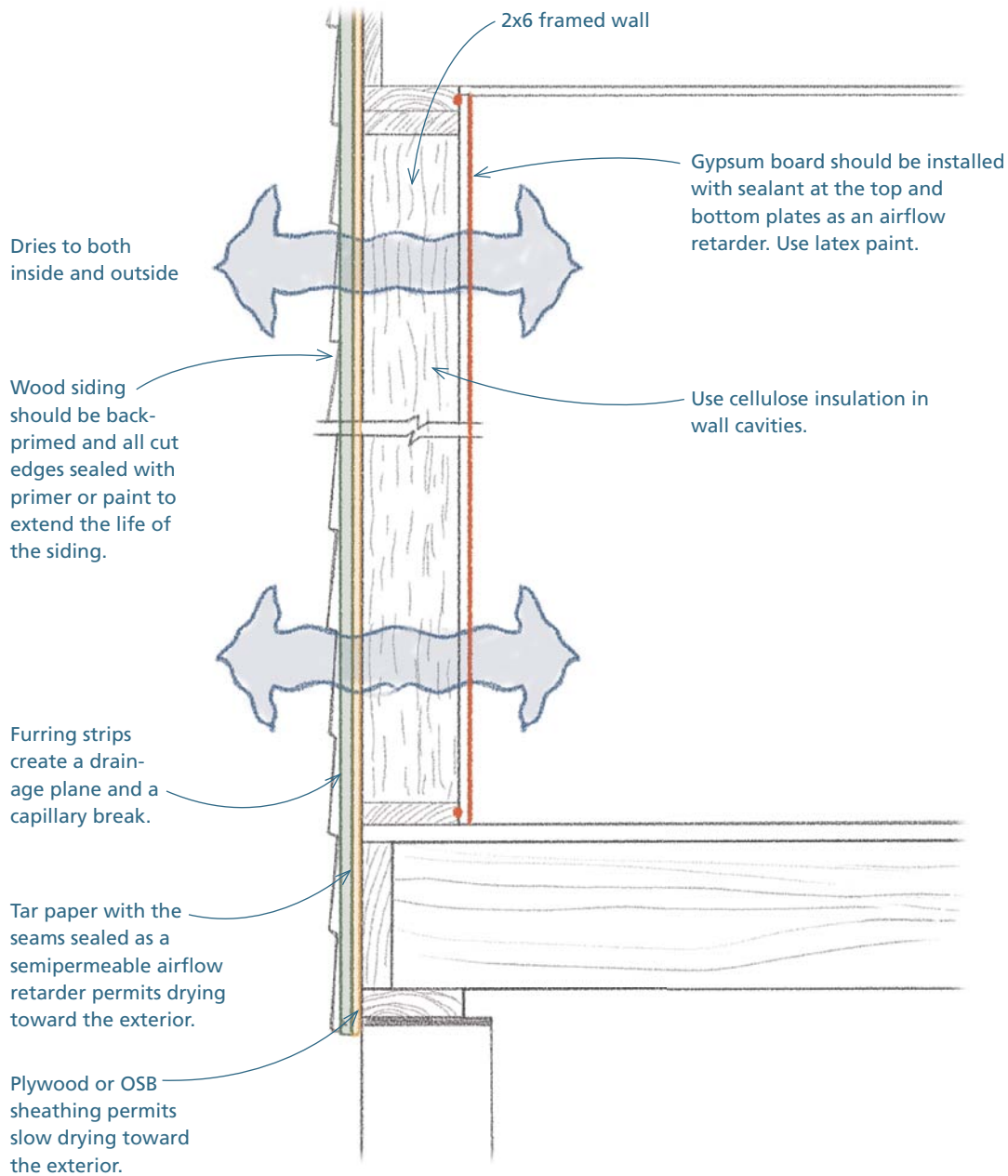

● WALLS FOR HOT/HUMID AREAS

In hot/humid climates, where air-conditioning is used much of the year, the air outside is typically hotter and wetter than inside air, creating inward pressure. Since plywood or OSB sheathing is not used in this sample assembly, an alternate method for resisting wall racking must be used, such as let-in bracing, steel-strap bracing, or inset sheer panels. Check with an HVAC contractor about balancing the air pressure on the inside with that on the outside.

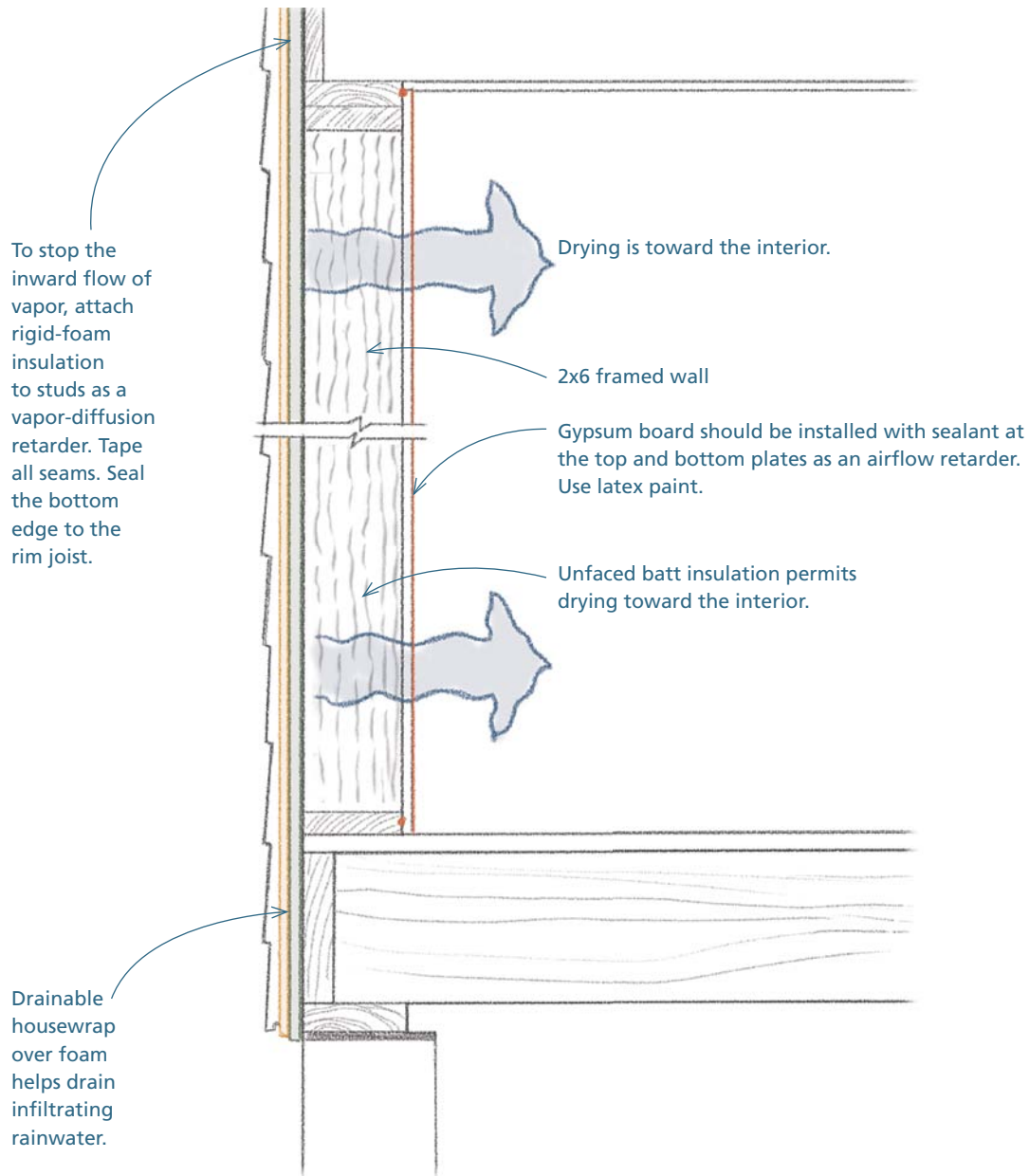

Controlling Vapor in Ceiling Assemblies

In a heated house, warm, moist air rises and presses against the highest ceiling. If the ceiling system has leaks, the air migrates into the ceiling assembly, where it can foster mildew and rot.

To prevent a buildup of moisture in the attic, historically builders have vented the space above the ceiling. This strategy is still common today. Recently, some building scientists have expressed concerns about this system—especially in hot, humid climates. The problem is similar to that of vented crawlspaces. Vents allow hot, humid air inside. If this air cools down, water vapor condenses. To avoid this, some building scientists advocate unvented roof systems. Key elements of this approach include finding and sealing off all potential leaks from the heated space into the ceiling, and using heavy insulation that prevents condensation. Unvented systems are not accepted by all building codes.

• CEILINGS FOR COLD AND MIXED CLIMATES

In a vented ceiling assembly, it's still important to keep as much of the conditioned air out of the attic as possible. If any moisture manages to breach this barrier, the ventilation facilitates drying toward the outside.

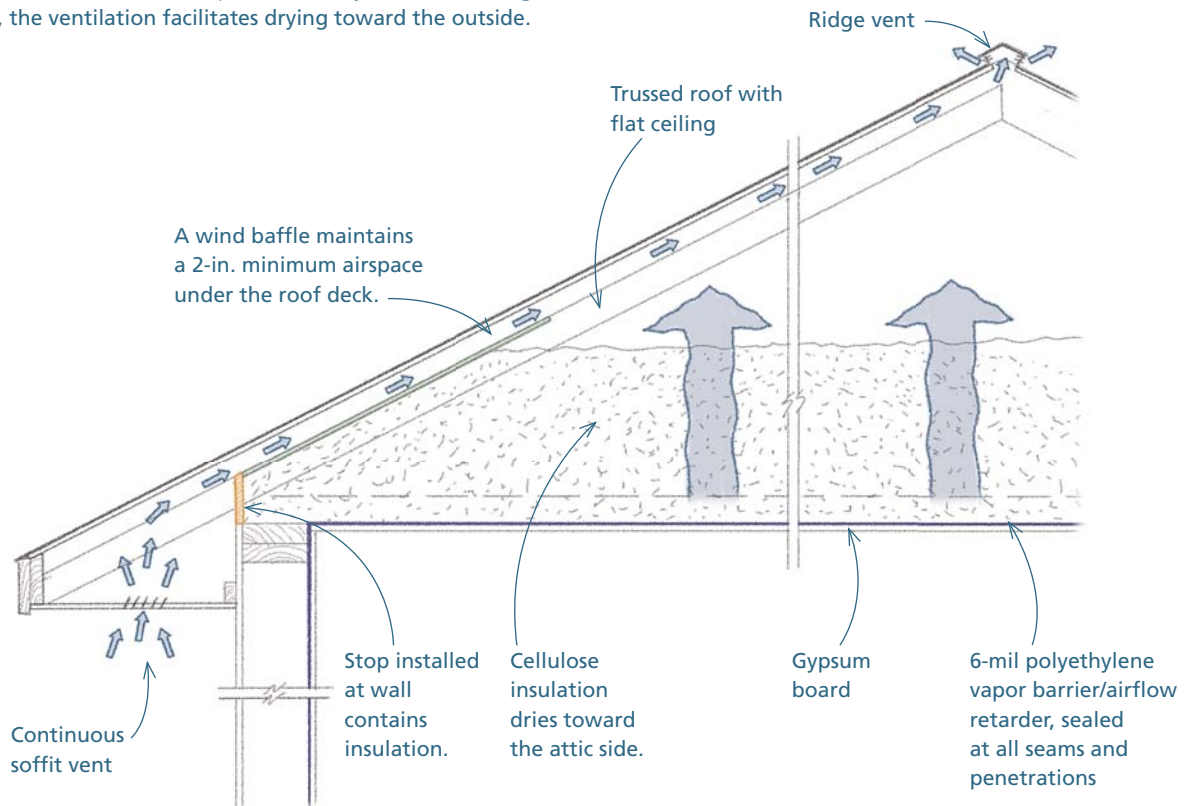

● CEILINGS FOR COOLING CLIMATE

In a cooling climate, the hot, humid air is mainly outside and the cool, dry air is inside. The tendency, then, is for warm air to move from the outside toward the inside. At some locations in the house, however, warm, moist air is generated by cooking, showers, and similar activities. This warm air rises. Because the moisture can come from both directions, the ceiling assembly should allow drying to take place toward both the exterior and the interior.

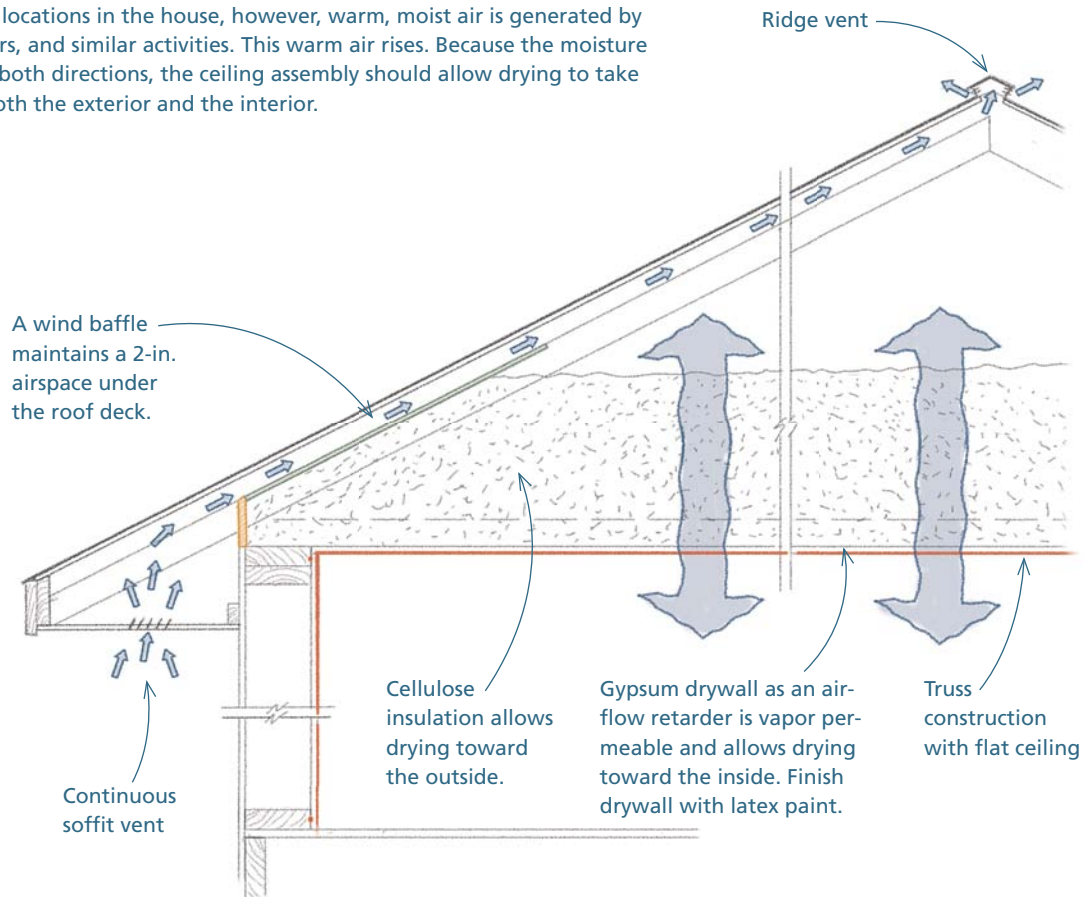

TOP TIP

Use IC-Rated Recessed Lights in Insulated Ceilings

Recessed lights produce a lot of heat. When insulation prevents this heat from dissipating, the units can be a fire hazard. Manufacturers have responded to this threat by producing insulation-contact (IC) recessed lights, which can be safely placed against insulation. When using recessed lights in an insulated ceiling, always make sure they are rated IC.

● FOAM SEALING AROUND WINDOWS AND DOORS

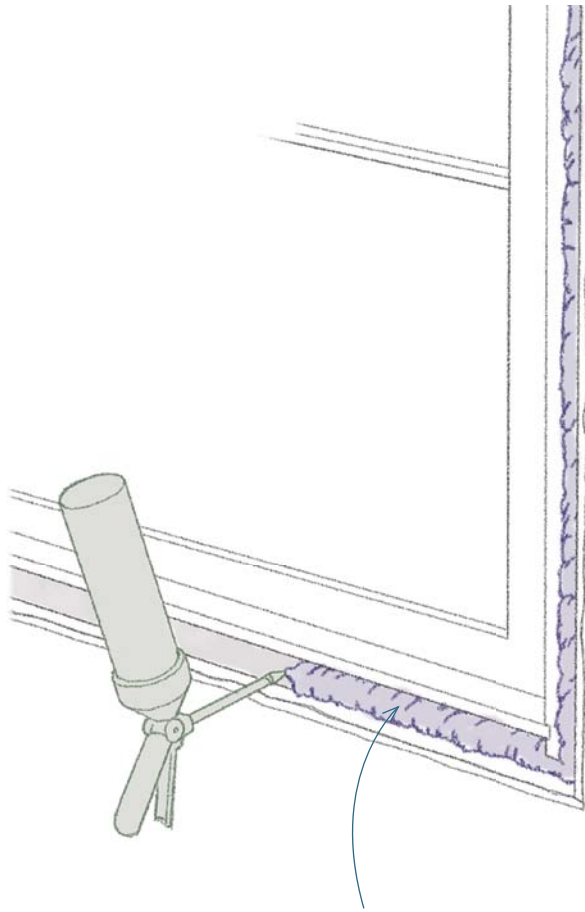

The space between the rough opening and a window or door unit is a common point of air leaks.

Seal gaps with low-expanding insulation, such as Dap® window and door foam. Avoid high-expanding foams, which can bow in door and window jambs.

Using Insulation to Control Vapor

Insulation can be used to control vapor in two ways. First, it can stop the flow of air through assemblies. Second, it can keep the temperature inside assemblies above the point at which vapor will condense into water (the dew point).

Insulation as an airflow retarder Some types of insulation are very effective at blocking the passage of air, particularly sprayed polyurethane foam. Others types, such as unfaced fiberglass batts, are not effective air barriers.

Insulation and Air Sealing

Many materials are used for insulation, but the three most common types in the United States are fiberglass, cellulose, and foam. Fiberglass is available in blankets that fit between framing members or as loose fill that is blown into place. Cellulose is available as loose fill that is blown into place. Foam comes in rigid sheets or as a liquid that is sprayed into place, where it expands as it dries. The price, the chemical make-up, and the physical properties of foams vary widely. Do your research before deciding on which to use.

In wood-framed houses, most insulation is installed after the building is under roof and the wiring, plumbing, and HVAC are complete. One important exception is the installation of rigid-foam sheathing, which is sometimes fastened to the exterior walls as the house is framed. This is often the only part of the insulation installed by the carpentry crew.

Specialty subcontractors, who know local code requirements and have the required equipment, often install insulation. Builders and remodelers are usually deterred from using their own crews to install cellulose and spray-foam insulation because they don't have the equipment or the special skills they need.

Fiberglass blankets are relatively easy to install, but these, too, are often farmed out to subcontractors. Because of their speed and familiarity with the code requirements, insulation contractors often do the job cheaper and faster than can be done in-house.

The importance of air sealing

Installing insulation without careful air sealing is like donning a heavy coat on a cold day and leaving it unbuttoned. Air sealing is the sum total of many little things—gluing the sheathing to the rim joist, carefully taping the seams of housewrap, and closing off walls before building soffits for cabinets. All of these steps seal the house from wasteful and damaging air movement.

This process continues after the frame is complete. Whether the person in charge of the job is a superintendent or a lead carpenter, he has to tie up the loose ends left between subcontractors. When plumbers or electricians drill holes in exterior assemblies, for example, the superintendent/lead carpenter has to make sure that those holes are sealed before the walls are covered with siding and drywall.

The superintendent/lead carpenter also is responsible for making sure insulation subcontractors do their jobs correctly.

Air sealing doesn't end with the insulation contractor. When the airtight drywall approach is specified, drywall installers also have a role in ensuring a tightly sealed house (for more on installing drywall, see chapter 8). Panels must be sealed to studs, and openings for electric boxes also must be sealed. Installers should take steps not to damage insulating facings on exterior walls.

No matter what kind of insulation you choose, it's a good idea to check the Department of Energy's recommended R-values for new wood-framed houses, which vary by climate zone.

Insulation as a tool to prevent condensation Another way to avoid condensation is to keep the temperature of surfaces within the building assembly higher than the point of condensation, or the dew point. This can be achieved by installing enough insulation so the point at which moisture vapor stops (the condensing surface) is kept above the dew points.

● DOUBLE-STUD WALLS

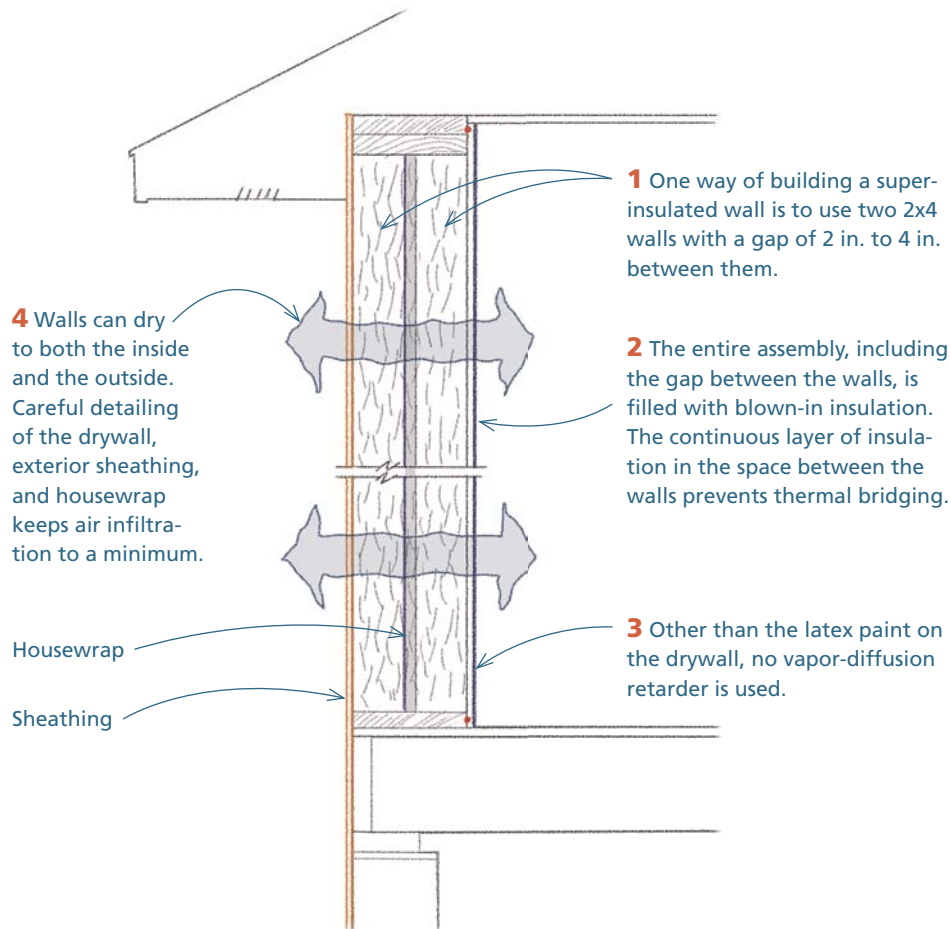

Framing materials have a significantly lower R-value than insulation in wall and roof cavities, which leads to a phenomenon in conventional construction called “thermal bridging.” Heat losses through framing are much higher than heat losses through the insulation. There are several ways to minimize this effect. One is to use rigid-foam insulation on the outside of the walls and even the roof. Another is to build double-stud walls with a space between the inner and outer wall, as shown in the drawing above. Builders considering these specialized assemblies should make sure they are detailed correctly for their climate zone.

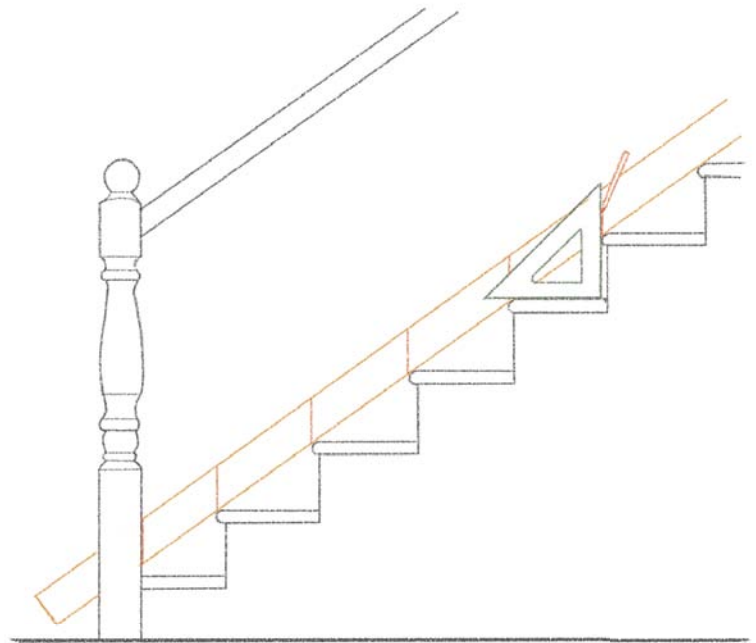
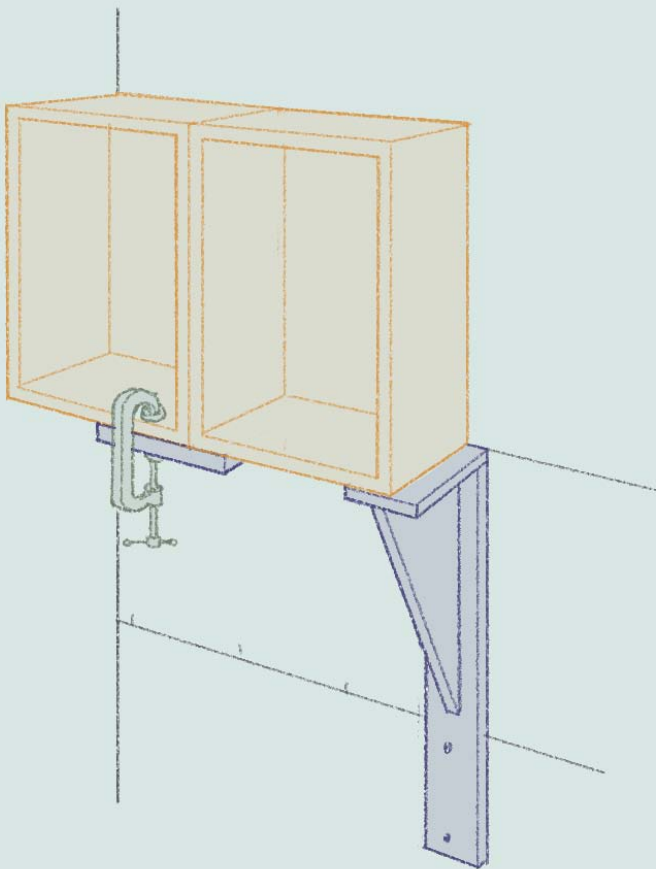
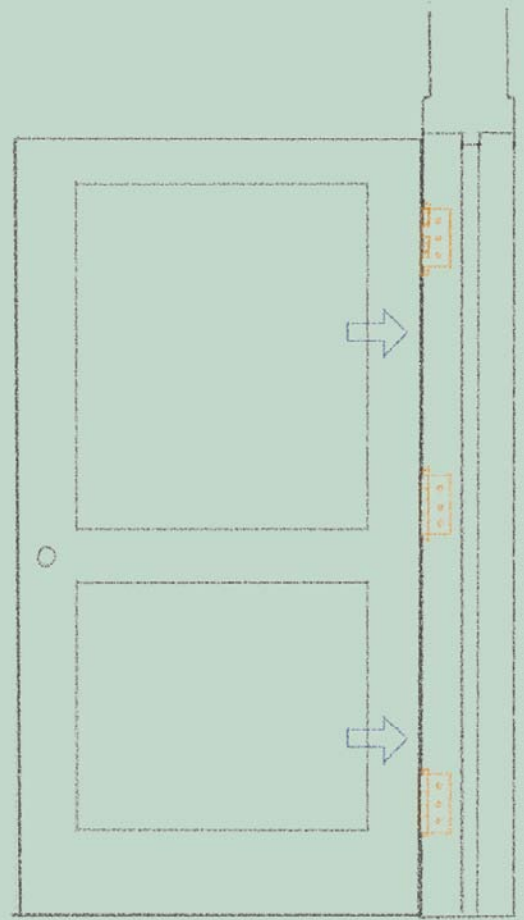
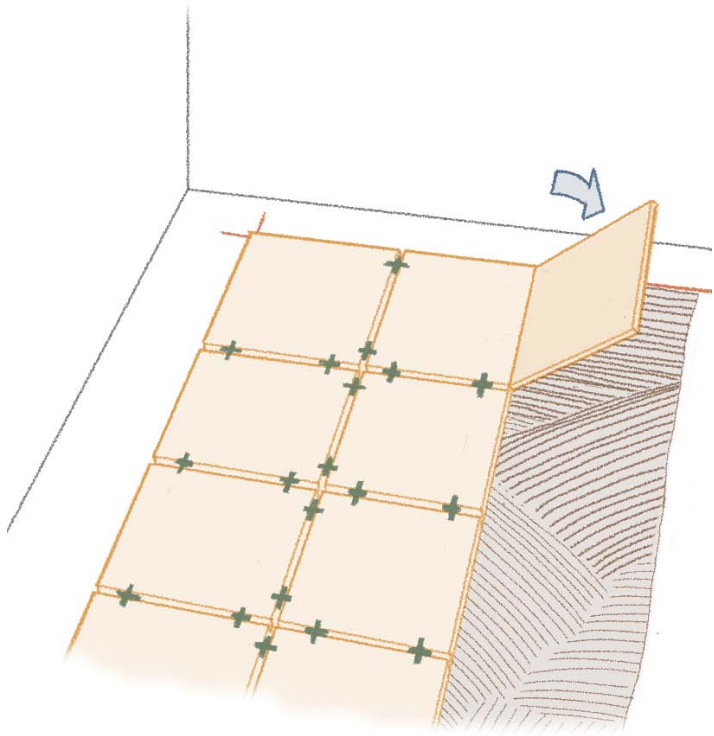

Finishing the House

CHAPTER 8

.....

310 Installing Wall and Floor Coverings

CHAPTER 9

.....

354 Hanging Doors

CHAPTER 10

.....

396 Installing Trim and Cabinets

CHAPTER 11

.....

442 Building Stairs

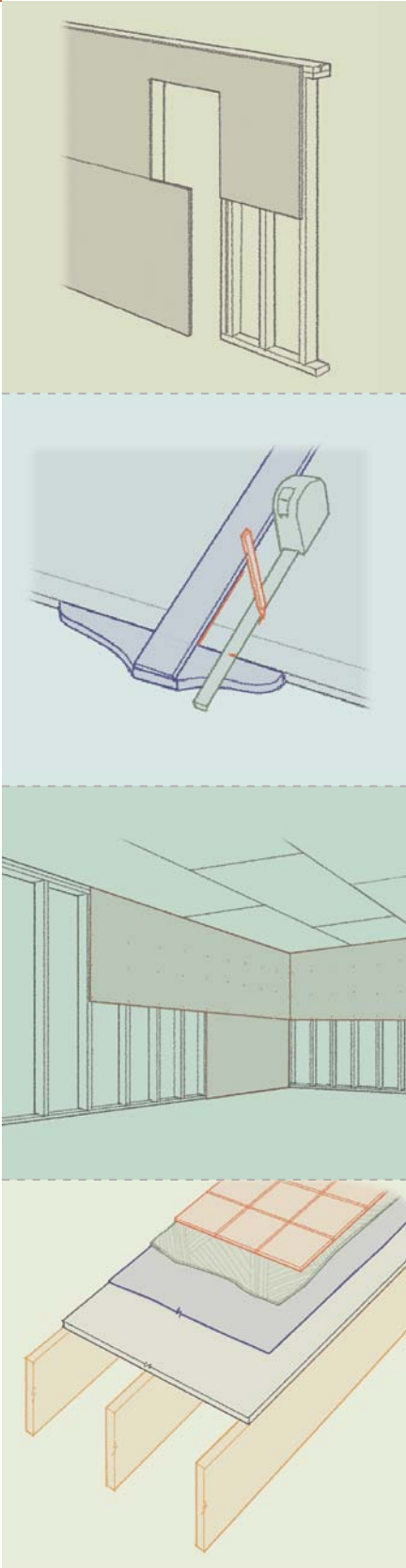

Installing Wall and Floor Coverings

AT THE SAME TIME THAT ROOFERS and siders are working on the outer shell of the house, other special-trade contractors can begin inside the house. While the studs and joists are still accessible, electricians, plumbers, and HVAC technicians thread wires, water lines, and ductwork through the skeleton of the frame. Because it will soon be covered, this work must now be tested and inspected according to local codes.

After these installations are approved, the walls, floors, and ceilings that comprise the building envelope are insulated. Then, interior surfaces can be finished. That process is the topic of this chapter.

Ceiling and Wall Coverings

Ceilings and interior walls are usually finished in drywall, plaster, wood, or tile. Because it's inexpensive and easy to work with, drywall (also called gypsum board, wallboard, and Sheetrock®) is by far the most common ceiling and wall covering. For this reason, it will be the prime focus of the first half of this chapter.

Drywall Basics

Drywall is a quickly installed, economical ceiling and wall covering that emerged in the post-World War II building boom. Like plywood, masonry units, and many other modern building products, drywall conforms to the “modular coordination” format developed in the late 1930s.

● MAKE-UP OF DRYWALL

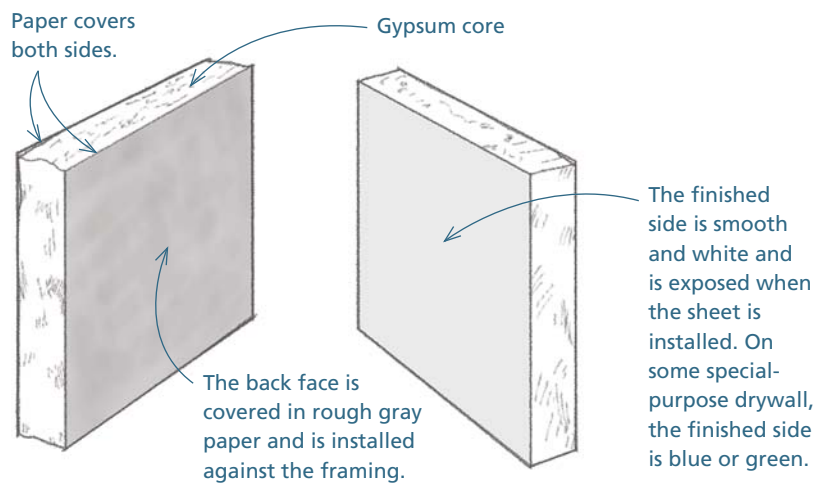

● PANEL SIZES

Walls built with precut studs are between 96¾ in. and 97½ in. tall, varying slightly by region. The ½-in. thickness of the drywall on the ceiling reduces this space to 96¼ in. to 97 in.—just enough to accommodate two full horizontal rows of drywall.



Standard drywall is 48 in. wide, which fits into the modular format of most modern buildings.



Drywall also comes in 54-in. widths for use with 9-ft.-high ceilings. It's usually a special order.

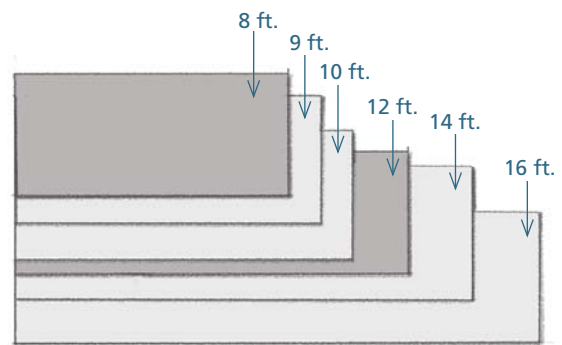

Panels 8 ft. and 12 ft. long are the most common, but drywall also is manufactured in 9-ft., 10-ft., 14-ft., and 16-ft. lengths. Nonstandard sizes are available from a drywall-supply house.

● **TAPERED EDGES**

Long edges on the finished face are tapered, creating a shallow recess about 5 in. wide when sheets are installed next to each other.

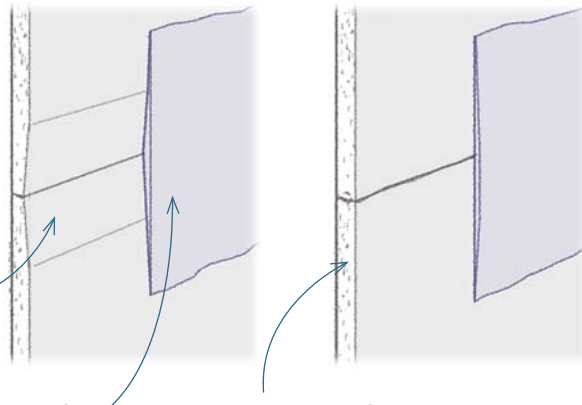

The recess provides space for drywall compound and tape.

The ends of panels are not tapered but are finished the same way.

TOP TIP

Finishing Butted Seams

Finishing panel ends without a taper is more difficult because the compound and tape build up above the face of the board. It requires a very wide joint that slopes gradually down to a feathered edge on both sides.

● **AVOIDING BUTTED SEAMS**

Choose panel lengths that keep the number of finished butt joints to a minimum. Before ordering drywall, measure each room and order the panels in lengths to match. Better planning means less waste and less work.

No butt joints

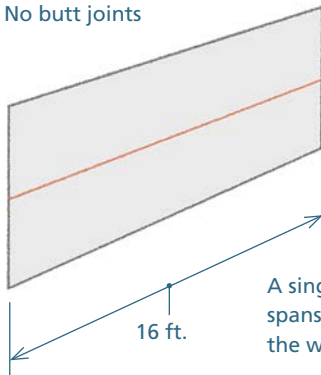

A single 16-ft. panel spans the length of the wall.

Two butt joints

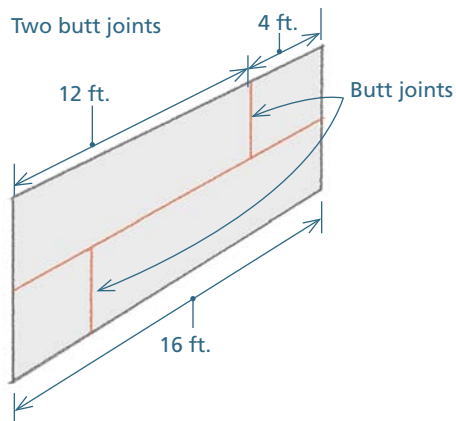

● **PANEL THICKNESS**

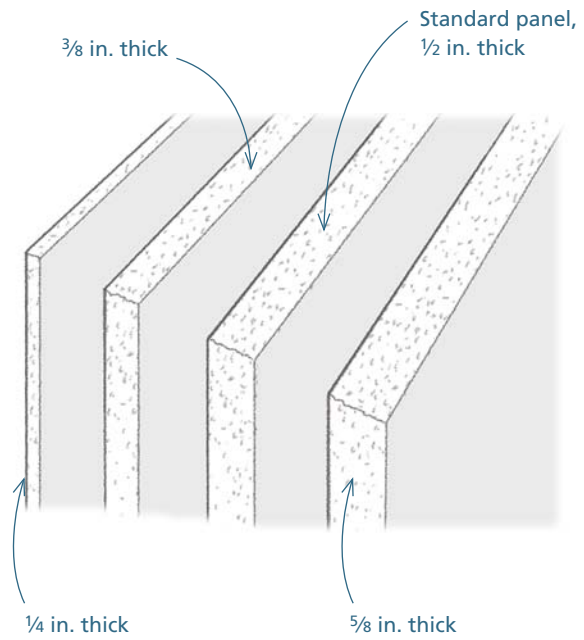

Panels 3/4 in. thick are also available.

Matching Wallboard to the Job

General-purpose ½-in.-thick drywall is standard for residential construction. However, there are other grades and thicknesses for special purposes:

Fire-resistant

Often called “firerock,” it features a specially formulated core for use in fire resistance-rated designs. Designated as Type X or Type C, it’s available in ½-in. and ⅝-in. thicknesses. (Type C provides a higher level of fire resistance than Type X.)

Moisture-resistant

With thicker and more water-resistant paper, it’s often specified for bathrooms and kitchens. Moisture-resistant drywall has green-colored paper on the finished face to distinguish it from regular drywall. It’s available in ½-in. thickness.

Abuse-resistant

Designed to be harder and tougher than regular drywall, abuse-resistant drywall is often specified for high-traffic areas in commercial construction. It’s available in ½-in. and ⅝-in. thicknesses.

Ceiling

Stiffer than regular drywall, it’s typically used where ceiling framing is 24 in. on center. Available in ½-in. thickness, it’s less likely to sag.

Flexible

Designed for covering curved surfaces, flexible drywall is available in ¼-in. thickness. It’s usually installed in two layers to match the thickness of regular drywall.

Paperless

The gypsum core is covered on both sides with a water-resistant fiberglass mat, which inhibits the growth of mold. It’s available in ½-in. thickness.

Nonstandard thickness

Panels ¼ in. and ⅜ in. thick are lighter and sometimes used in lieu of ½-in. drywall to cover damaged plaster in remodeling jobs. Panels ⅝ in. and ¾ in. thick are often specified to increase fire resistance or add stiffness.

Hanging Drywall

Drywall is a building system designed for speed. It's soft and easy to cut, and precise measuring and fitting is not necessary or even desirable. The goal of the drywall hanger should be to do an adequate job and do it quickly. The basics are:

- Fasten the boards securely to the frame.
- Set the screws (or nails) below the finished face of the board.
- Keep most of the seams $\frac{3}{8}$ in. or less in width.

The biggest challenges in hanging drywall are the same as those for moving drywall, namely, the size and weight of the panels and the fact that they break easily.

TOP TIP

Work to Sensible Tolerances

.....
Because drywall is so fragile, it often breaks when it's forced into a tight space. It's necessary, then, to leave a bit of play. Loose fits also increase productivity. These tolerances vary from place to place during the installation. It's important to learn how close you need to be in some places and what you can "get away with" in others.
.....

ESSENTIAL SKILLS

Estimating Wallboard

.....

The main goal in drawing up a drywall order is to minimize the number of butt joints. That will be easier to achieve if your supplier offers lengths of up to 16 ft. Look for a specialist supplier. Most general building suppliers offer only 8-ft. and 12-ft. lengths. Start by finding out what's available in your area, then go from room to room and tally up the quantities needed for each length.

First, determine the length

.....

On each section of the ceilings and walls in each room, begin by measuring perpendicular to the supporting members of the frame (ceiling joists, trusses, or studs). This measurement determines the length of the board needed. Sometimes you'll need more than one board to cover the length, which means you'll have a butt joint.

Second, determine the quantity

.....

After determining the length, measure parallel to the supports to find the number of boards needed at that length. You'll need one board for every 4 ft. Because walls are usually 8 ft. tall, they typically require two boards. On a wall with a door, the lower board will terminate at the opening.

Designate quantities for each room

.....

In addition to drawing up a bill of goods for the entire order of wallboard, designate the numbers and lengths that go in each room. The supplier can then use this list to get the boards in or, at least, near the rooms where the boards are needed.

WAYS OF WORKING

Carrying Drywall

When you carry drywall, keep in mind that it's a fragile material. It can easily break if you allow it to bend excessively or set it down on a corner. To avoid breaking the boards, follow these guidelines:

- Carry the drywall in a vertical position, with one person at each end. Drywall that's carried flat bends excessively and can break.
- If possible, leave the panels in their two-sheet bundles. Doing so decreases how much they will flex. If the bundles are too heavy, you may have to open them and carry one piece at a time. But be extra careful to keep single boards from bowing too much.
- Don't set the sheet down on one corner; lower the panel down so that the bottom edge is square to the floor. If you want to store it flat, use two people and support the center as you lower it into the flat position.

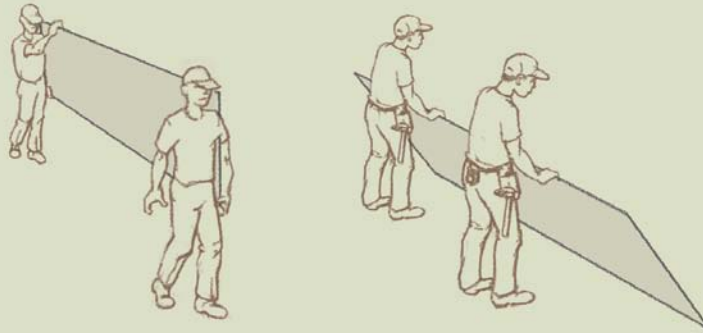

TOP TIP

Protecting Doors and Windows

A bundle of drywall is a heavy, awkward load. Here are a few tips to help avoid damage to doors and windows as you bring drywall into the house:

- If possible, schedule the delivery before you hang doors and windows. If you don't want to hold up the installation of the doors, windows, and siding, consider leaving out a single window designated for the drywall delivery. After you get the drywall in the house, install the window and finish the siding.
- If you've already installed the door, pull it off the hinges and store it in a safe place during the delivery. Build a simple protective cap for the doorsill.
- If the window is already installed, you can usually remove the sash and build a protective cover over the sill.

Tools and Techniques for Cutting Drywall

The most common tools for cutting drywall are a utility knife and two types of handsaws made for drywall. In addition, there are a variety of special-purpose hand tools designed to speed up specific cutting tasks (see “Special-Purpose Hand Tools for Cutting Drywall” on p. 318). There’s also an electric router that’s used mainly for cutting around electric boxes and fixtures. Depending on the situation, drywall can be cut before or after the board is installed.

● CROSSCUTTING DRYWALL BEFORE IT’S HUNG

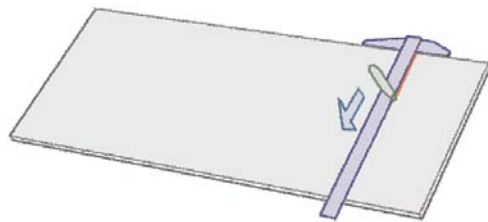

1 Hold a 48-in. drywall T-square at the desired length on the finished face of the board.

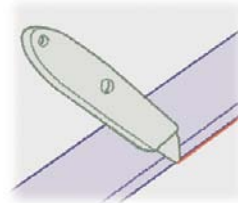

2 Run a utility knife along the edge of the square to cut through the paper, with the panel flat on the floor or standing on edge.

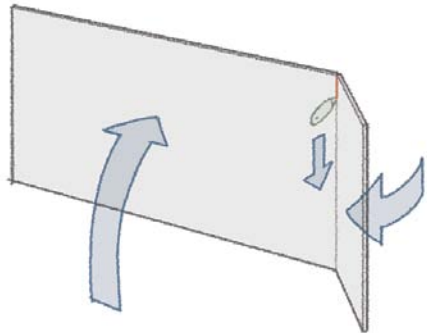

4 Rotate the smaller portion of the panel back until it’s more than 90° from the front.

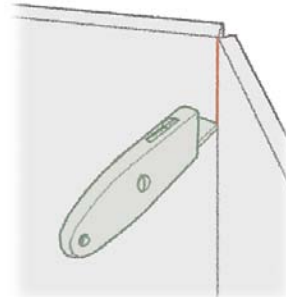

5 Use the knife to cut the paper on the back of the board along the crease. You can make this second cut from the front side (by cutting through the broken seam) or the back side. It doesn’t matter; do what’s convenient and fast.

3 Stand the panel on edge if it has been cut in the flat position. Place your knee or a hand behind the incised line, and swing the panel on one side of the incision back to break the core along the line.

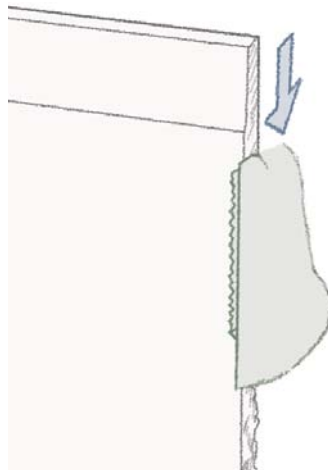

6 After making the cut, run a drywall rasp over the edge a few times. It will smooth the edge and help the piece fit easily into place.

● RIP CUTTING DRYWALL BEFORE IT'S HUNG

Professional drywall hangers use several methods to rip wallboard along its length quickly. This method requires just a chalkline and a knife.

1 With the board lying flat and the finished face up, snap the line at the correct dimension.

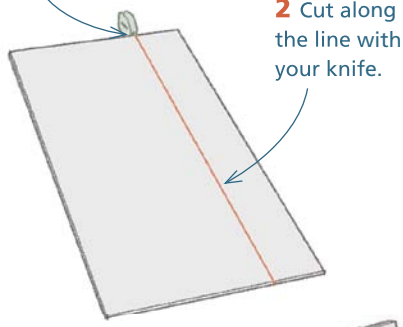

2 Cut along the line with your knife.

3 Raise the board to a vertical position, with the smaller portion up, and snap the upper piece down, folding it against the lower portion.

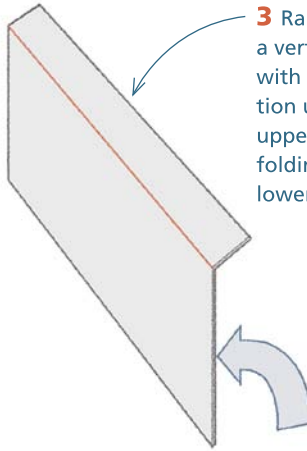

4 Carefully lower the folded board down to a flat position, with the finished face of the larger portion facing down.

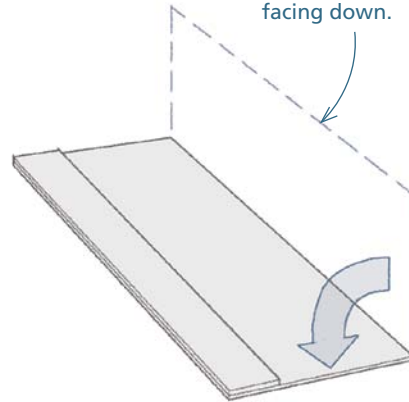

5 Lift the smaller piece up, and cut the paper on the back along the crease.

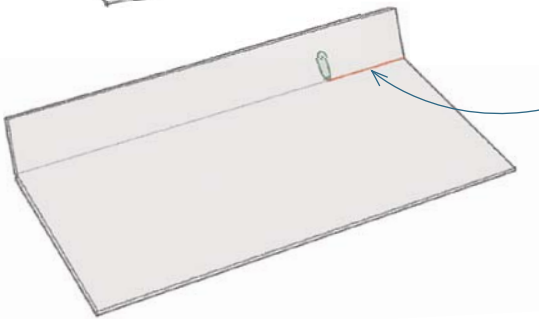

● CUTTING AROUND INTERIOR DOOR OPENINGS

To cut the upper piece along an interior door opening, use a 15-in. drywall saw, followed by a utility knife.

1 After hanging the board across the opening, use a 15-in. drywall saw to cut along the sides of the opening. Work from the finished side of the board, and keep the saw against the side of the frame.

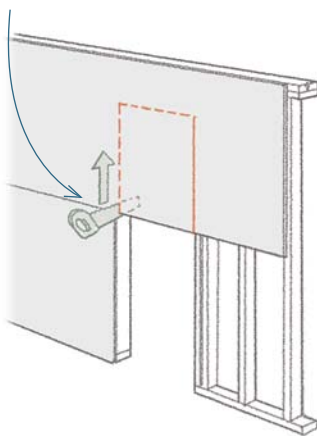

2 Duck under the panel and, from the back side of the board, run a utility knife along the underside of the header.

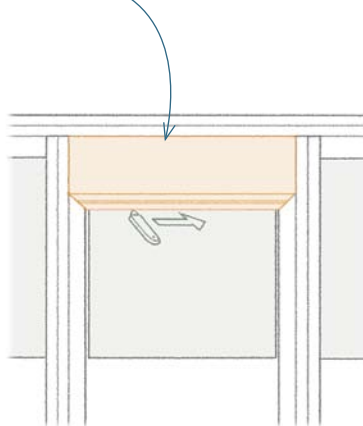

3 Push the flap that covers the doorway up to snap the board along the incised line, and use a knife to cut the paper on the front of the flap.

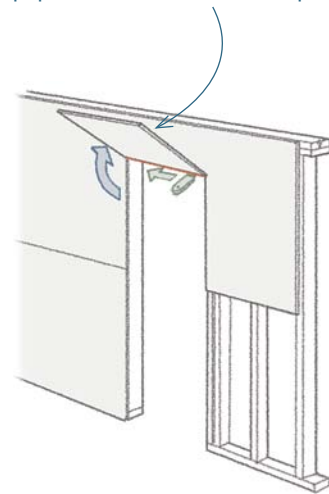

Special-Purpose Hand Tools for Cutting Drywall

Because hanging drywall is a production-oriented task, there are several tools available that help increase the speed of laying out and cutting the boards.

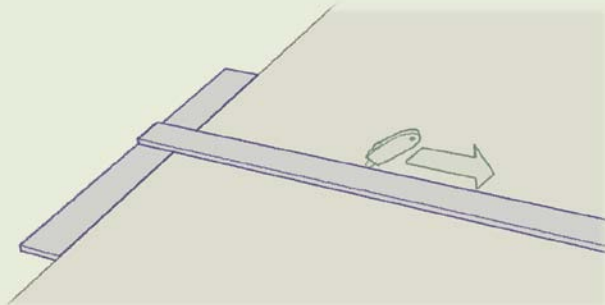

1. A 48-in. drywall T-square. This is the standard tool for guiding crosscuts in drywall. Set the square over the edge of the panel, align with the mark, and use as a guide as you cut the panel with a knife.

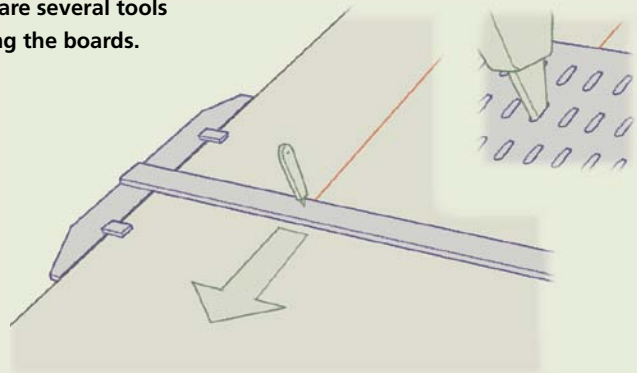

2. Johnson Level & Tool RockRipper®. This 24-in. T-square is used to rip drywall along its length. The blade of the square has a football-shaped hole every $\frac{1}{16}$ in. Put the point of the knife in the appropriate hole, and slide the fence along the edge.

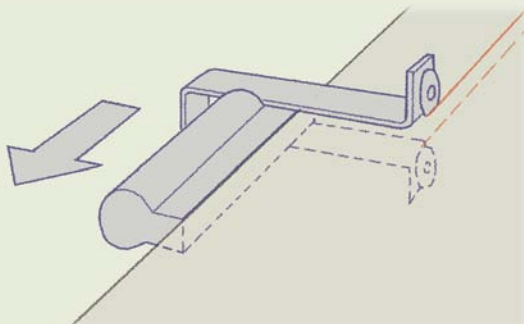

3. Warner® Tool Drywall Edge Cutter. The Edge Cutter is good for cutting narrow strips of drywall (from $\frac{1}{2}$ in. to $4\frac{1}{2}$ in. wide). As the fence slides along the edge of the panel, opposing toothed wheels score the paper on both sides of the sheet. The strip then breaks off along the line. This tool is especially effective at cutting very narrow strips quickly and cleanly.

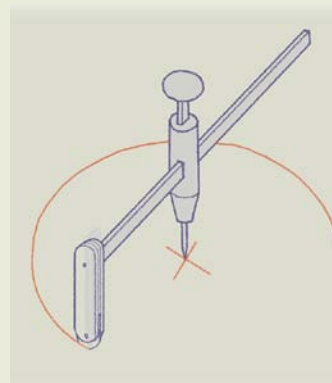

4. Circle cutter. A drywall circle cutter consists of a short aluminum arm with an adjustable pin on one end and a case-hardened steel cutting wheel at the other end. After marking

the center of the circle, set the tool to the radius of the desired circle. Push the pin through the marked point and rotate the arm. As you swing the arm, apply pressure over the wheel to cut the circumference of the circle in the paper.

● CUTTING THE LOWER PIECE IN A DOORWAY

1 Install the board so that it runs past the opening.

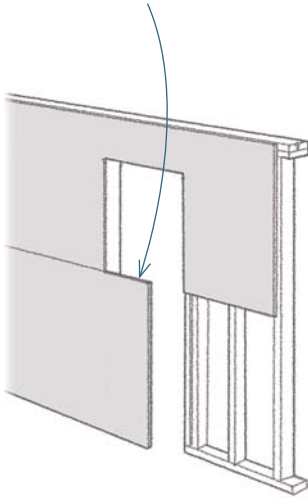

2 From the back of the panel, run the knife up the side of the opening, and snap the portion that runs into the opening out away from the doorway.

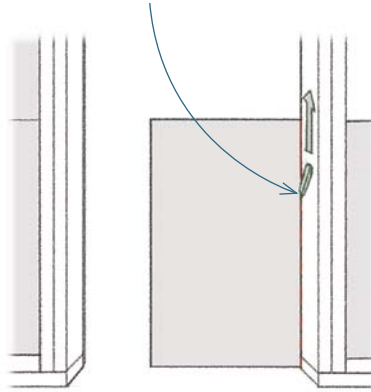

3 Cut the crease on the front of the board.

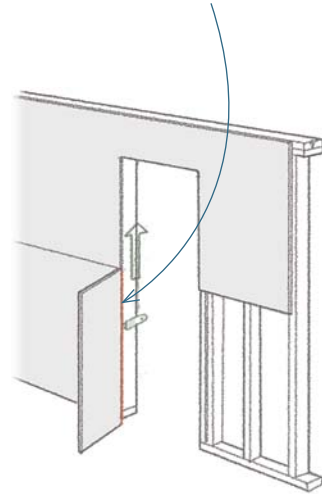

● CUTTING AROUND EXTERIOR DOORS AND WINDOWS

Because exterior doors and windows are installed before the drywall is hung, you can't hang a full board and then cut it in place, as described for interior door openings. In these situations, you have to measure the locations of the opening, transfer those measurements to the board, then cut the board before hanging it.

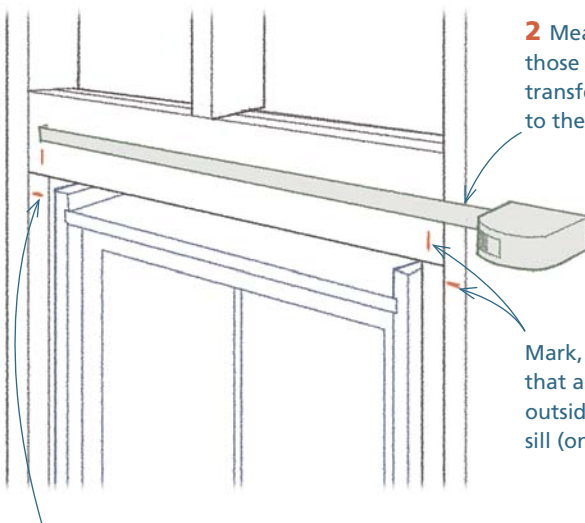

2 Measure to those points, and transfer the points to the board.

Mark, by eye, points that are about $\frac{5}{8}$ in. outside the jamb and sill (on windows).

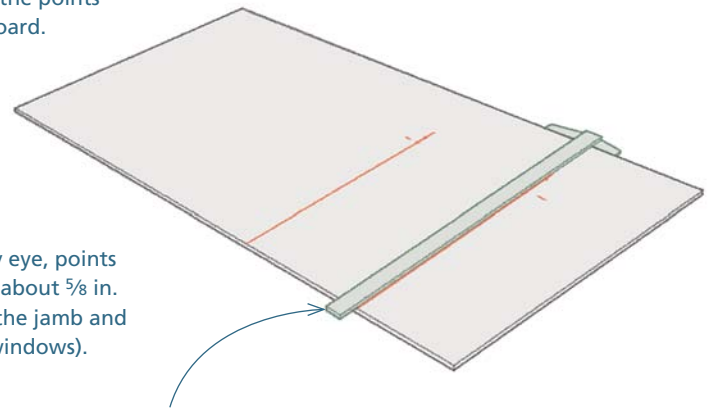

1 Because the gap between the jamb and the drywall will be covered by casing (which is typically at least $2\frac{1}{4}$ in. wide), the measuring tolerance for exterior windows and doors is very coarse. In most cases, you can safely use a $\frac{5}{8}$ -in. gap around exterior window and door jambs.

3 Use a drywall T-square to lay out the side cuts and a chalkline or a straightedge to lay out the horizontal cuts. Then stand the board on edge, and use a 15-in. drywall saw to make the side cut or cuts. Cut along the horizontal line with a knife, push the flap out away from the incised line, and cut the back paper along the crease.

Cutting around Electric Switches, Outlets, and Small Fixtures

You can cut out spaces for electric boxes and fixtures with hand tools or a drywall router. The following steps describe the process using hand tools. A technique for cutting around these openings with a router is discussed on p. 322.

The tolerances for electric boxes and many ceiling fixtures are small. If you want to avoid clunky oversize plates or time-consuming repairs, you need to cut no more than $\frac{1}{4}$ in. outside of electric boxes and $\frac{3}{8}$ in. outside of many ceiling fixtures.

• CUTTING AROUND CIRCULAR FIXTURES AND ELECTRIC BOXES IN CEILINGS

To lay out around recessed lights and electric boxes, find the center, then use a compass or a circle cutter to scribe the circumference.

1 Measure from a point $\frac{1}{4}$ in. in from the wall frame to the front and back of the circle. (The $\frac{1}{4}$ in. allows for a small gap between the end of the panel and the wall frame.)

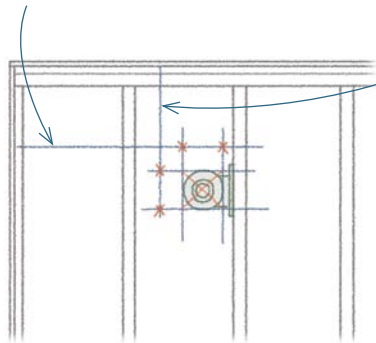

2 Measure from a point $\frac{1}{4}$ in. in from the wall frame to the top and bottom of the circle.

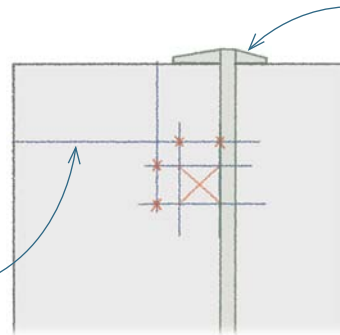

3 Transfer these dimensions to the panel.

4 Use a T-square and a small flat square to draw a square box at these dimensions.

5 Mark the center of the square by drawing two diagonal lines from the corners of the box.

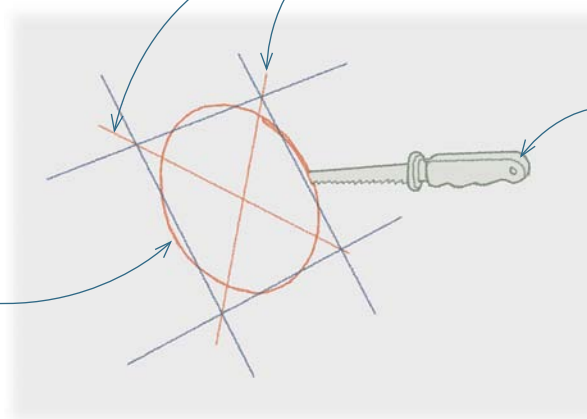

6 Set a compass or circle cutter to a radius that's $\frac{3}{8}$ in. larger than the dimension from the center point to the side of the square. (Make it larger if you know you can work to greater tolerances.) Using the center point, scribe the circumference of the circle with a compass or a circle cutter.

7 Cut the circle out with a drywall keyhole saw.

TOP TIP

Using Lipstick to Mark Boxes and Fixtures

.....
One simple way to mark boxes (and fixtures) is to use lipstick. Cut the board to fit the space, and coat the edge of the box with lipstick. Set the board in place, and press it against the box to transfer the location of the box. Some installers use chalk instead of lipstick.
.....

● CUTTING AROUND RECTANGULAR SWITCH BOXES

Wall switch boxes are usually placed with the center 4 ft. off the floor, which is in the seam between the upper and lower pieces of drywall. As a result, the cut is done in two stages, with one cut out for the upper board and a second cut for the lower board.

Upper board

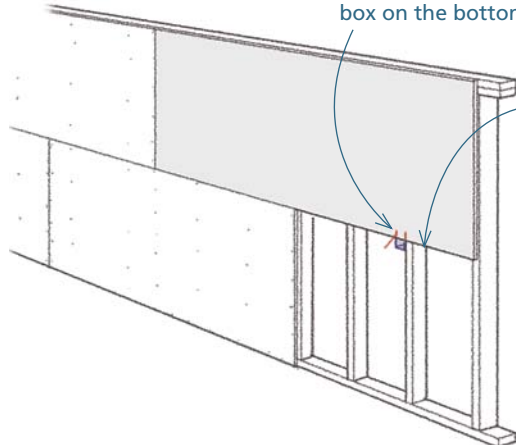

1 Hold the board in place on the wall, and mark the locations of the sides of the box on the bottom edge of the board.

2 Measure the distance from the bottom of the box to the bottom edge of the board. Remove the board.

3 Use a square to lay out the sides of the box.

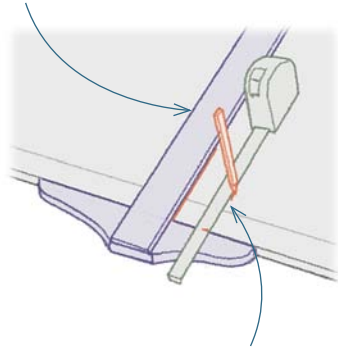

4 Hold your tape measure so that the amount you measured to the bottom of the box extends past the bottom edge of the board. Mark the board at a dimension equal to the size of the box (usually $3\frac{7}{8}$ in.). Lay out the top horizontal line of the box.

5 Use a drywall key-hole saw to cut out for the box. Cut just outside the line. Install the upper board.

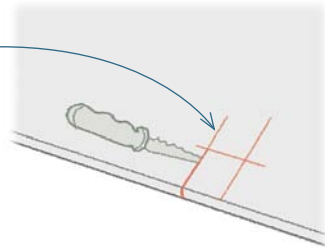

Lower board

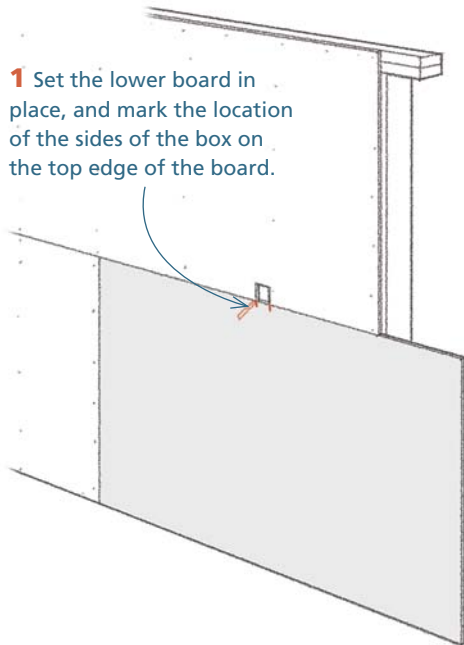

1 Set the lower board in place, and mark the location of the sides of the box on the top edge of the board.

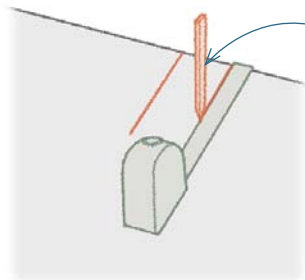

2 Remove the board and lay out the sides with a square. Measure down from the bottom of the (installed) upper board to the bottom of the box. Transfer this measurement to the board, and lay out the location of the bottom of the box.

3 Use a keyhole saw to cut out for the box. Cut just outside the lines.



● CUTTING AROUND ELECTRICAL OUTLET BOXES

Outlet boxes are usually 12 in. to 16 in. off the floor.

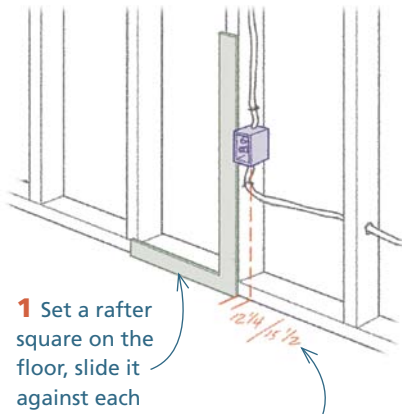

1 Set a rafter square on the floor, slide it against each side of the box, and mark the floor to indicate the locations of the sides.

2 At the same time, read the measurements of the top and bottom of the box off the floor. Write these dimensions on the floor.

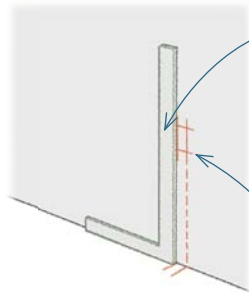

3 After cutting the drywall to length, bring it to the wall and temporarily hang it with two screws.

4 Set the square on the marks on the floor, and scribe lines representing the sides of the box.

5 Use the scale on the square to mark the top and bottom measurements.

6 Unscrew the board, and use a square to mark the top and bottom lines.

7 Use a drywall key-hole saw to cut about $\frac{1}{8}$ in. outside the lines of the layout.

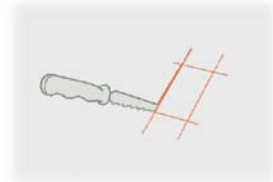

● USING A DRYWALL ROUTER

Drywall routers speed up installation considerably, even if they are a little tricky to work with. Equipped with a special bit, the router follows the perimeter of electric boxes and fixtures as it cuts the board.

Push the wires in the box as far back as possible to lessen the possibility of hitting them with the router bit. Measure roughly to the center of the box or fixture along both the length and width of the space that will be covered by the board. Note or mark the dimensions for use after the board is hung.

Hang the board. Use just enough screws to hold the board in place; don't put any screws in the area around the box or fixture.

1 Use the dimensions noted earlier to mark the approximate center of the box or fixture.

2 Set the depth of the router bit so it will cut all the way through the drywall and make firm contact with the sides of the box but not so deep as to jeopardize the wiring in the box. A good depth for $\frac{1}{2}$ -in. drywall is $\frac{3}{4}$ in. below the base of the router.

3 With the router running, plunge the bit through the center mark.

4 Move the router slowly to the side until you make contact with the side of the box. Carefully withdraw the router until the bit can slide over the edge of the box. Plunge the router back in as soon as you feel it clear the edge.

5 Run the router counter-clockwise around the outside of the box to complete the cut.

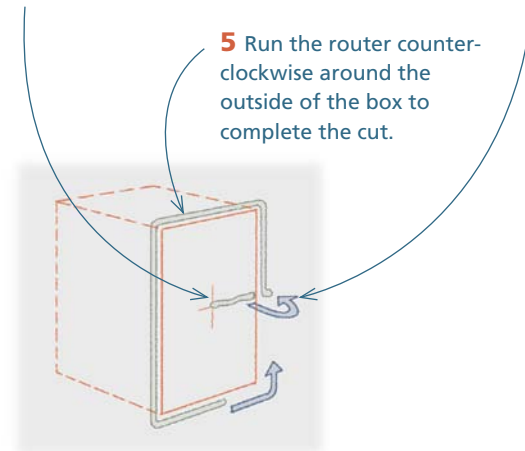
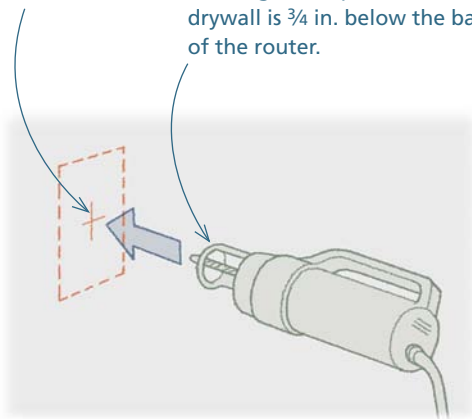

WAYS OF WORKING

Three Fastening Systems

Drywall screws

The bugle-shaped heads can be set below the surface without tearing the paper. For wood framing, use coarse-threaded screws; for metal studs, use fine-threaded screws. For ½-in. drywall, use screws that are 1⅛ in. or 1¼ in. long. It's essential to set the screws to the proper depth, which is below the surface but not so deep as to break the paper. To do this, you need a drywall screw gun, which sets screws precisely.

To make sure the screws are set deep enough, run the blade of a 6-in. knife over the head; if the head is proud of the surface, you'll be able to feel it with the knife.

The screws should be placed every 12 in. along each joist, truss, or stud. Keep screws about 7 in. away from ceiling/wall intersections.

Drywall nails

Once the standard fasteners for hanging wallboard, drywall nails are rarely used nowadays, except in conjunction with glue or to attach corner bead. Still, drywall nails are an acceptable alternative to screws if you rarely hang drywall and want to avoid the expense of a screw gun.

Use 1¼-in. ring-shanked drywall nails for ½-in. drywall. Install a nail every 7 in. along each joist, truss, or stud.

Drywall adhesive

To cut down on the number of fasteners, some drywall hangers use adhesive to help hold the boards to the frame. On exterior walls and ceilings, the adhesive also can be part of an air-retarder system called the airtight drywall approach (ADA).

When using adhesive:

- Apply adhesive for a single panel at a time.
- Use just enough nails or screws to hold the board in place; two fasteners per support is usually sufficient.
- If you're using the airtight drywall approach, make sure you apply a continuous bead of adhesive to the top and bottom plates.
- The adhesive must be applied directly to the wood frame. Don't use glue if you have a polyethylene vapor barrier or the frame is covered by paper- or foil-backed insulation.

Set drywall screws so the head is below the surface but not breaking the paper.

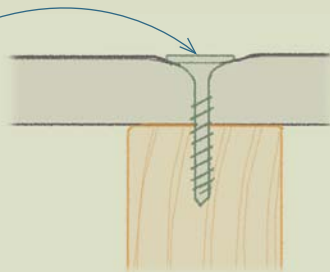

To set a nail below the surface, hit it until a shallow dimple appears around the head. Don't pound the nail so hard that you crush the gypsum core or break the paper.

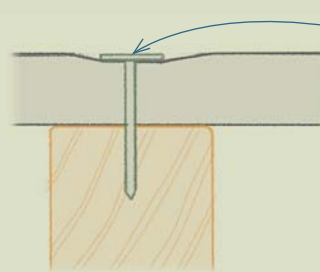

Hanging Ceilings and Walls

Ceilings should be hung before walls. You'll need a pair of sturdy benches (about 18 in. to 24 in. high for 8-ft.-high ceilings) to stand on as you measure and then hang the boards. A simple site-built T-support about $\frac{1}{4}$ in. taller than the finished ceiling height is nice to have, too. It helps hold up the panel as you fasten it to the frame.

The sidebar on pp. 326–327 illustrates the installation of a typical ceiling and walls in a house with standard 8-ft. ceilings.

● INSTALLING CORNER BEADS



1 Outside corners are typically covered with metal or plastic corner beads, which provide a straight edge to work as you build up a crisp and durable corner.

2 Cut the bead to fit, center it on the corner, and attach it with nails or a special corner crimping tool. When the corner extends down to the floor, leave about a $\frac{3}{4}$ -in. gap at the floor to allow for settling of the frame. If you plan on installing hardwood floors, leave a 1-in. gap.

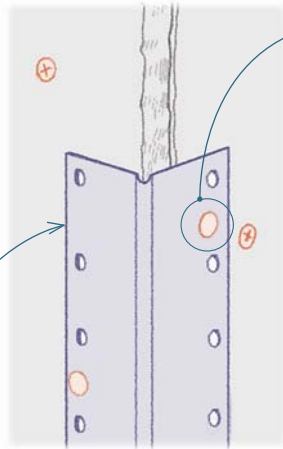

3 It's essential to keep the heads of the fasteners lower than the bead. If they project above the bead, they won't get covered by the drywall compound.

4 One way to avoid this problem is to use a drywall crimper, which doesn't require any fasteners. If you don't want to invest in a drywall crimper, use nails, which have flatter heads than screws, to attach the corner bead.

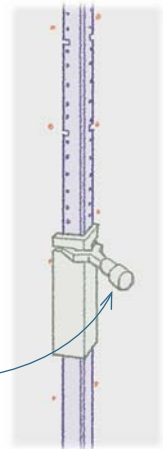

TOP TIP

Dealing with Arched Openings

.....
If you have to install drywall to an arched opening, attach two layers of flexible $\frac{1}{4}$ -in. drywall for the underside of the arch. And use arch bead, a bendable plastic corner bead, for the curved section of the opening.
.....

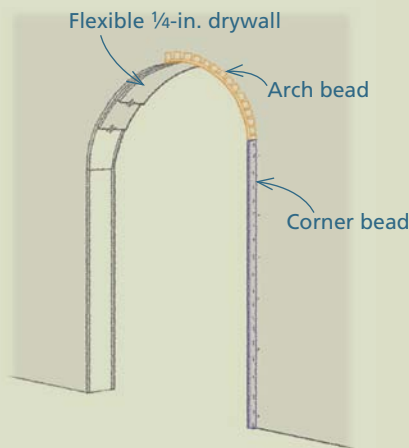

Finishing Drywall

The joints, fasteners, and corners of drywall must be finished with drywall compound, often called “mud,” and tape. For accomplished finishers, this process requires three coats of compound, some light sanding, and a bit of final touch-up work. Less-experienced finishers often require additional coats and much more sanding. If the job is done well, the screws and seams should be smooth, the corners should be crisp and straight, and the edges of the compound should blend seamlessly into the surface of the drywall.

Finishing Materials

The basic materials for finishing drywall are drywall tape and drywall compound. There are two types of tape and two types of compound.

Tapes

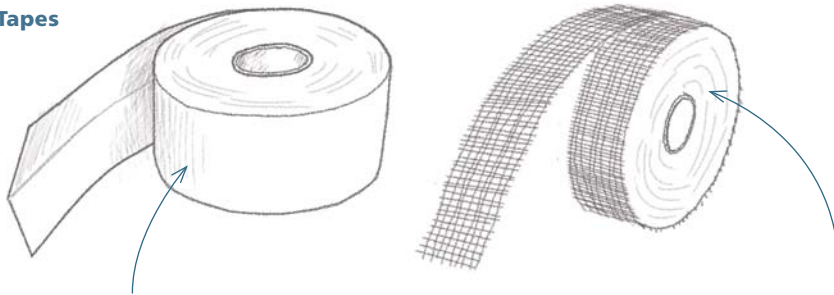

Paper tape is a general-purpose tape used for inside corners, tapered seams, and butt seams. It can be used with a variety of compound materials. To attach it to the wall, embed it in a wet coat of compound.

Mesh tape comes with a coat of adhesive and can be stuck directly on the wall without embedding it in compound. Mesh tape is not as strong as paper tape. It should be used only for tapered seams, not inside corners or butted seams. After mesh tape is applied to tapered seams, the first coat covering it should be a high-strength compound.

Compounds

Drying-type compound usually comes ready-mixed in 1-gal. or 5-gal. buckets. It cures through evaporation, often requiring a full day for each of the first two coats and several hours for the final coat (longer in cool, wet weather). Drying-type compound comes in three varieties: taping, topping, and general purpose.

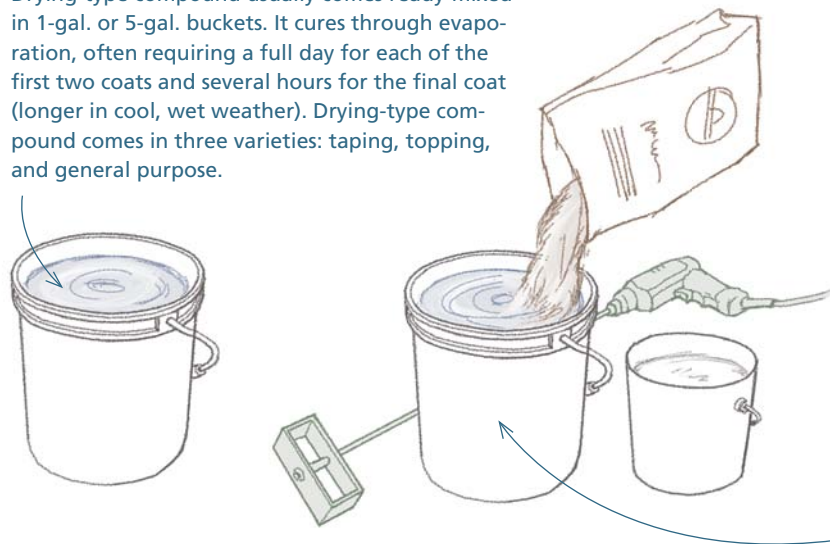

Setting-type compound comes in a powdered form and is mixed with water. It cures by chemical reaction in times ranging from a half-hour to half a day. The fast-drying compound is great for repairs and small jobs. Compounds with longer open times are usually used for larger jobs. Setting-type compounds are strong and a good choice for the first coat over mesh tape. On the down side, setting-type compounds can be difficult to work with.

Hanging Drywall on Ceilings and Walls

Before hanging any panels, mark the locations of the joists or trusses on the wall. Also, make any necessary cutouts for electrical boxes or fixtures.

There are two ways to lift drywall panels into position: with a mechanical hoist or by hand.

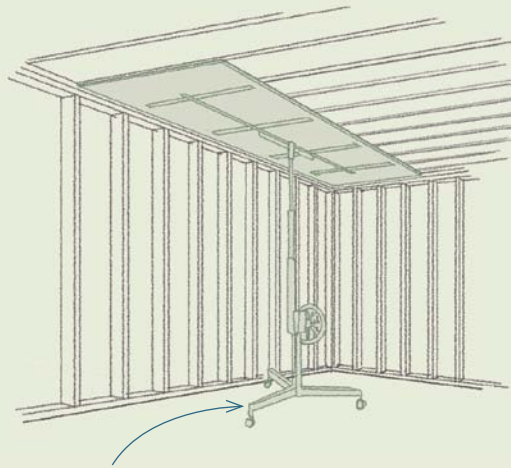

1 If you're using a mechanical hoist, such as a Telpro® Panellift® (often available at equipment rental yards), set the carriage in the vertical position, and center the panel on the carriage. Rotate the carriage to the horizontal position, and crank up the hoist until the board reaches the ceiling.

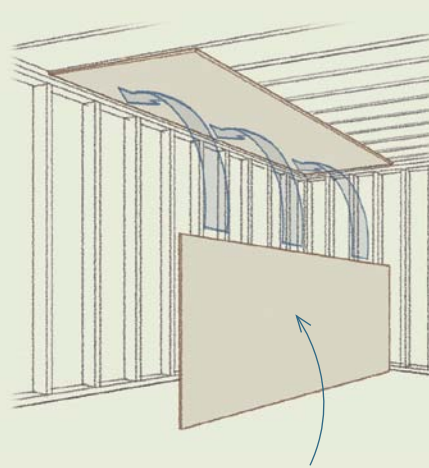

2 If you're doing the job manually, you need at least two people to hold boards up to 12 ft. and three people for longer boards. For a 12-ft. board, each person should be about 3 ft. in from the end. With the board sitting on edge, lift it straight up and rotate it overhead. Raise one end up to the ceiling and slide it into the corner, then raise the other end.

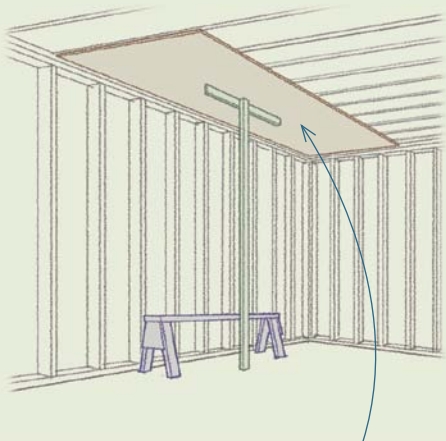

3 If you have a T-support handy, push it tight against the board to help hold the load. Place one screw every 10 in. to 12 in. along each joist or truss.

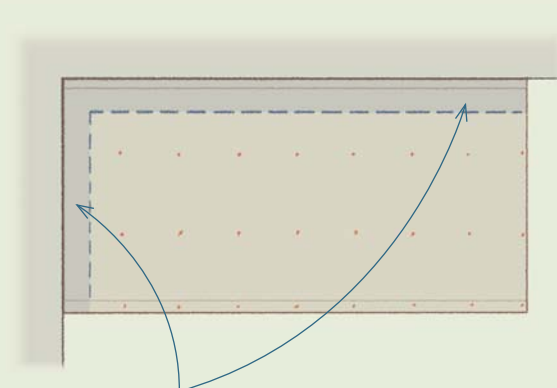

4 Keep fasteners at least 7 in. away from the edge. Omitting these fasteners permits seasonal movement of the ceiling frame without cracking the joint in the wall/ceiling intersection. This measure is especially important with trusses. Panels installed on the walls help support the perimeter of the ceiling.

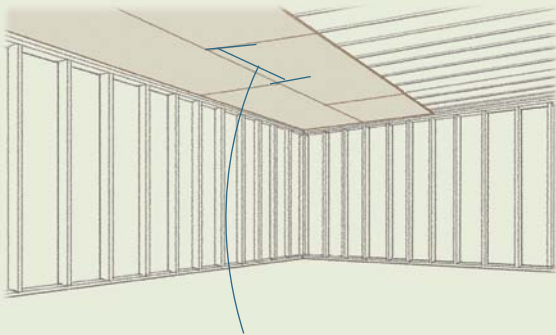

5 As you plan the layout of panels, remember that all butt joints in adjacent rows should be offset by at least 4 ft.

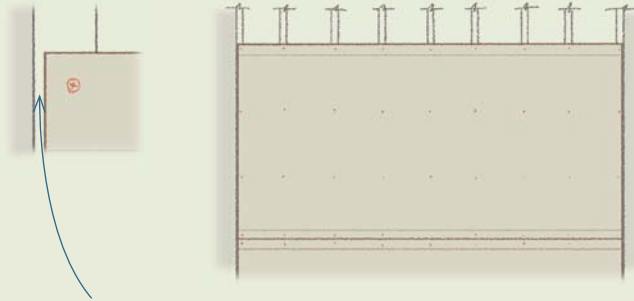

6 If one board spans the ceiling, measure wall to wall and subtract $\frac{1}{2}$ in. from the measurement. This leaves a $\frac{1}{4}$ -in. gap at each end, which will be covered by the thickness of the drywall when you hang the walls. If you can't span the ceiling with one board, measure from the wall to the center of the joist or truss where it will land and subtract $\frac{1}{4}$ in.

• HANGING WALLS

In a house with standard 8-ft.-high ceilings, there are two rows of drywall. The top row should be hung first.

1 Mark the stud locations on the ceiling and floor.

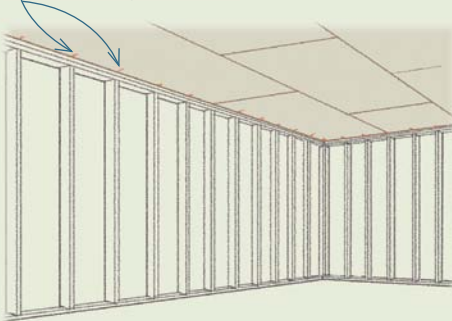

If there will be butt seams, make sure you plan to offset those in the lower row from those in the upper row by at least 4 ft.

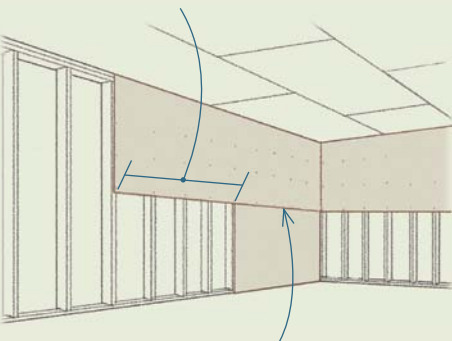

4 After cutting the lower board to length, measure and cut for the openings, then install the lower boards tight to the bottom edge of the upper boards.

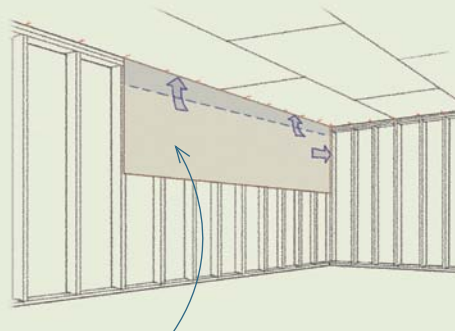

2 Measure and cut the upper panel. Measure the length of the room, and subtract $\frac{1}{4}$ in. for each inside corner. Use the techniques described on p. 317 to measure and cut for the openings.

3 Grip the panel by the bottom edge, and push it tight against the ceiling as you fasten it to the wall. As with the ceilings, keep the screws about 7 in. away from the wall/ceiling intersection.

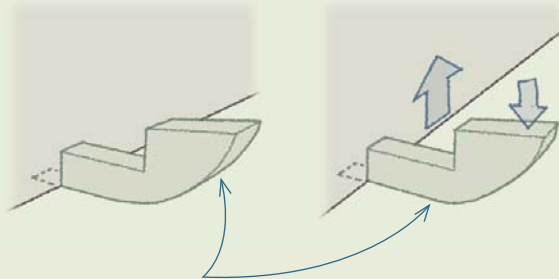

5 Use a drywall kicker, an inexpensive tool that works like a seesaw, to lever the lower piece tight against the upper piece. Stepping on the outside end of the kicker forces the inside end up and lifts the board tight against the upper panel.

6 Screw the panel in place, and make any cuts that you've saved until this point.

● THE FIRST COAT: TAPING

In this initial step, tape all the seams and apply a first coat over screw heads and outside corners.

STEP 1 Tapered seams

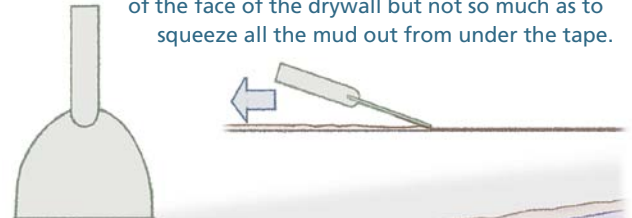
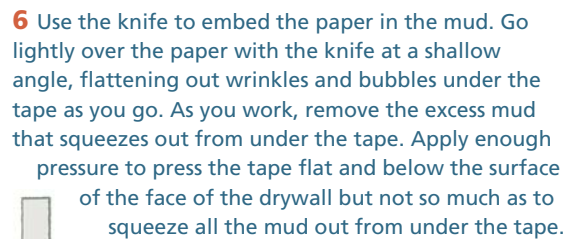
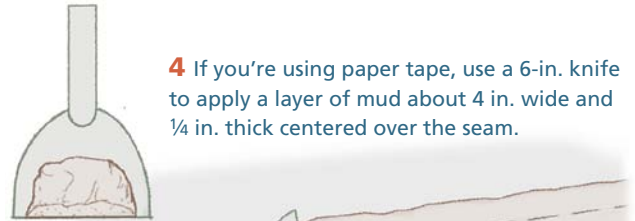
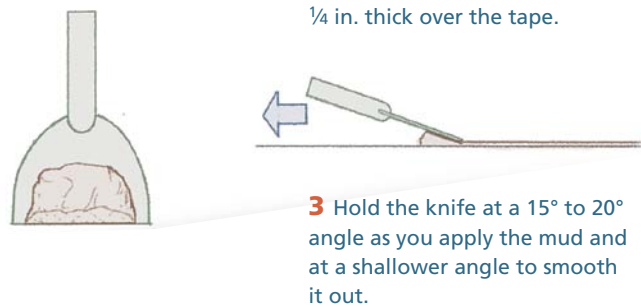
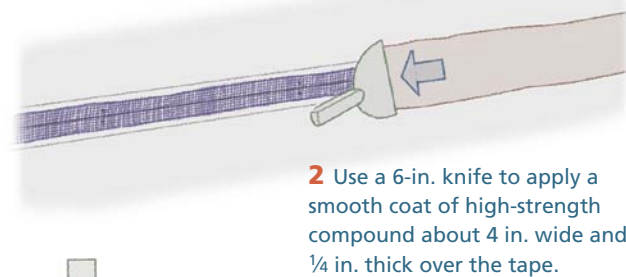
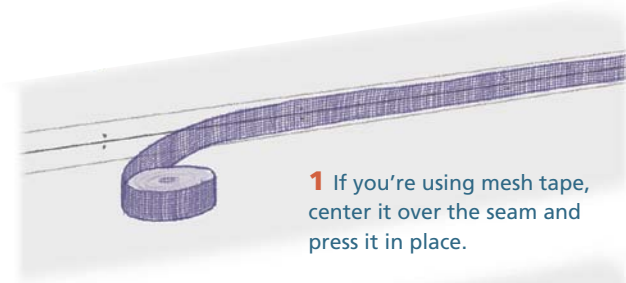

STEP 2 Screw heads

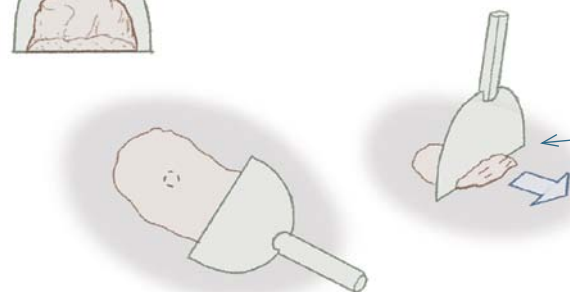
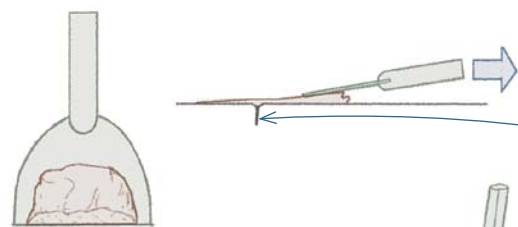

STEP 3 Inside corners

Finishing inside corners is the most challenging part of the job. It's best to begin these seams after the perpendicular tapered joints have dried.

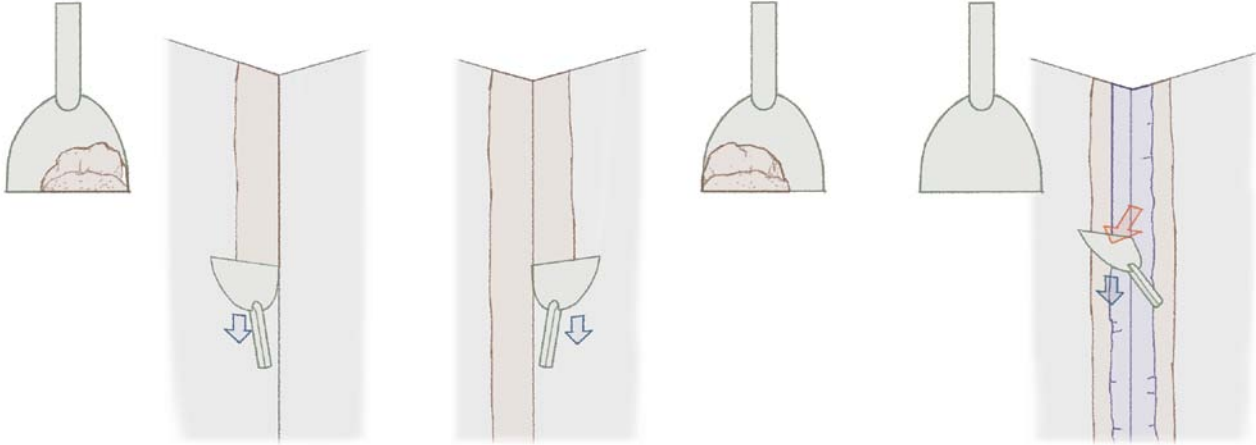

1 Load one side of the knife, and apply a line of mud about 2½ in. wide and ¼ in. deep to one side of the corner.

2 Load the other side of the knife, and apply a similar line of mud to the other side of the corner. Always load the side of the knife that will be in the corner, and hold the knife at a shallow angle (10° to 15°) as you apply the mud to the surface.

3 Cut a piece of paper tape to length, and fold it along the crease. Use your fingers to press the tape into the mud, with the crease centered in the corner. Clean your knife frequently, and use several light passes to work the tape into the corner. Run the side of the knife along the side of the corner as you work each corner. Remove mud that squeezes out from under the tape, and work the tape flat but don't apply so much pressure that you squeeze all of the compound out from under the tape.

STEP 4 Butt seams

Ideally, there are few butt seams. Tape these at the same time that you do the inside corners. Use the same basic technique that you used for the tapered seams, but keep in mind that the swath of compound over these seams will have to be much wider than the compound over the (recessed) tapered seams.

STEP 5 Outside corners

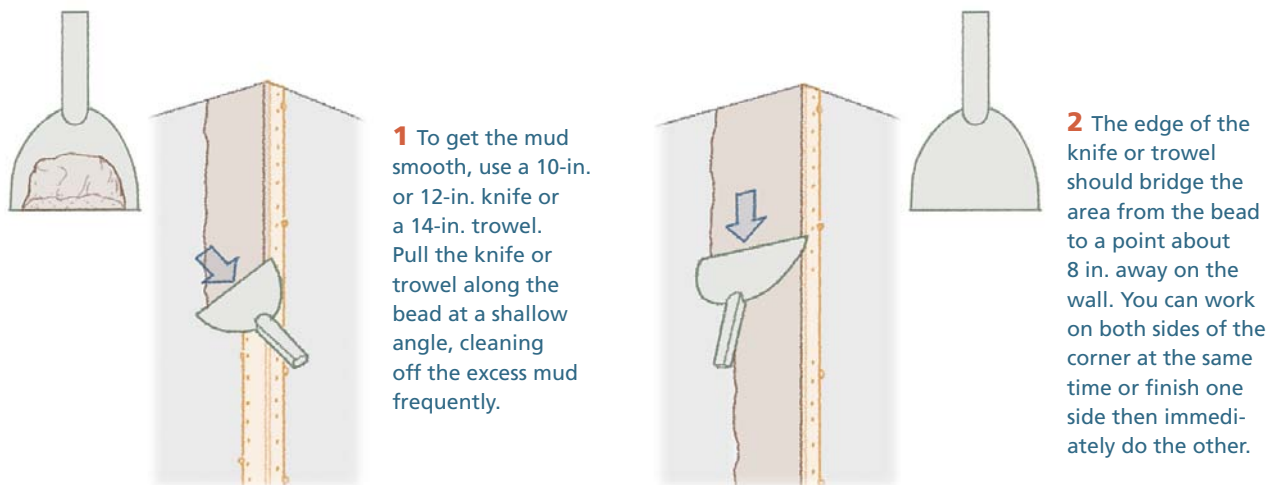

1 To get the mud smooth, use a 10-in. or 12-in. knife or a 14-in. trowel. Pull the knife or trowel along the bead at a shallow angle, cleaning off the excess mud frequently.

2 The edge of the knife or trowel should bridge the area from the bead to a point about 8 in. away on the wall. You can work on both sides of the corner at the same time or finish one side then immediately do the other.

● SECOND COAT: BUILDING UP THE MUD

In this coat, go over all of the areas covered in the first coat. The object is to cover the tape and build up and widen all the mudded areas.

STEP 1 Tapered seams

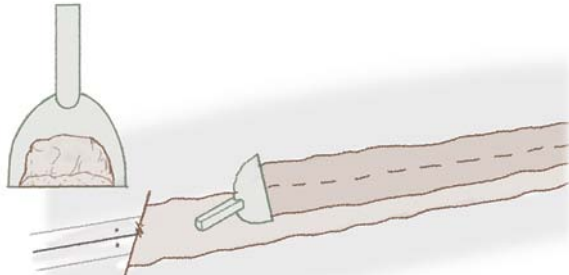

1 Use a 6-in. knife to apply a swath of compound about 8 in. wide and $\frac{3}{8}$ in. thick over the tape.

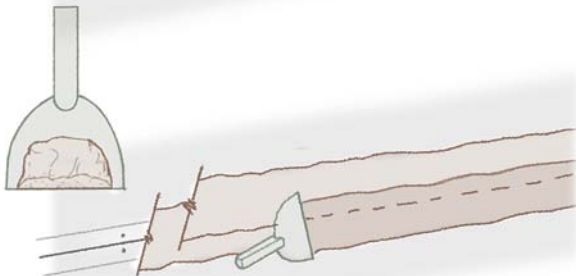

2 Make a second pass to cover the other side of the seam.

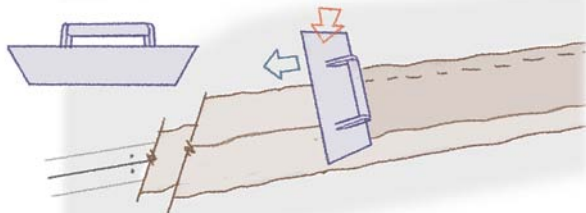

3 Use a 12-in. knife or a 14-in. drywall trowel to smooth out the compound, feathering one side of the seam . . .

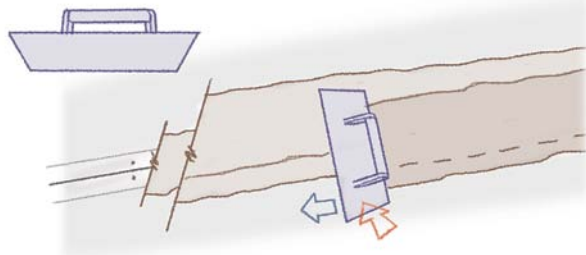

4 . . . and then the other side, holding the knife or trowel at a shallow angle (about 10°).

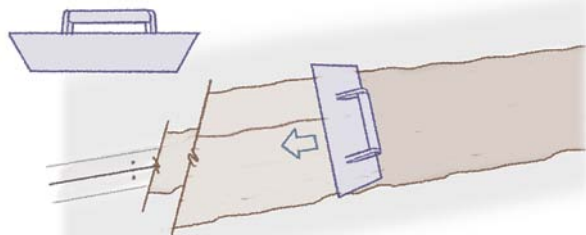

5 Finally, smooth the middle.

STEP 2 Screw heads

Recoat the screw heads using the same technique as you used on the first coat.

TOP TIP

Speeding Up Corners

When finishing inside corners, the mud on one side of the corner must dry before a second coat can be applied on the other side. For this reason, finishers often use setting-type mortar for this coat on the inside corners. It dries faster than general-purpose compound and reduces the wait.

STEP 3 Inside corners

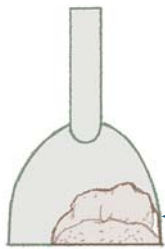

1 Cut off a workable portion of mud with a 6-in. knife, and load one side of the knife with mud.

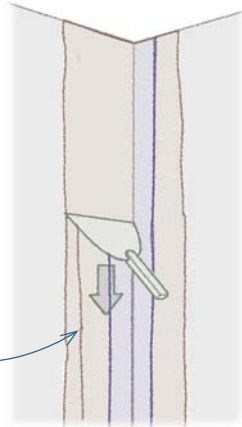

2 Hold the knife at a shallow angle (10° to 15°) with the loaded side of the knife in the corner. As you apply the mud to one side of the corner, keep the side of the knife against the other side of the corner.

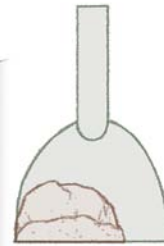
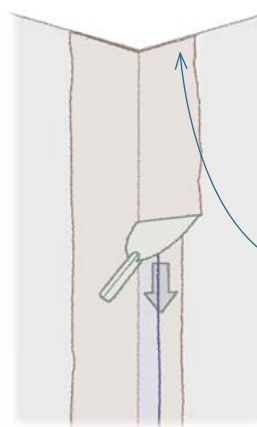

3 Once the first side dries completely, coat the second side using the same technique as you used on the first.

STEP 4 Butt joints

Use a 6-in. knife to apply a 12-in.- to 16-in.-wide swath on the joint. This will require three or four passes with the knife. Smooth the joints using the same technique described for tapered joints.

STEP 5 Outside corners

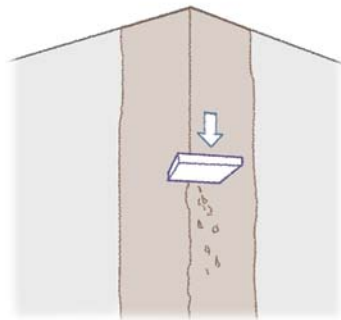

1 Clear any dried mud off of the bead. One way to do this is to use a block of wood. Hold the end of the block square to the bead (at about a 45° angle to both walls) and at about a 20° angle and run the block up along the bead. The dried mud on the bead should crumble off as you apply moderate pressure.

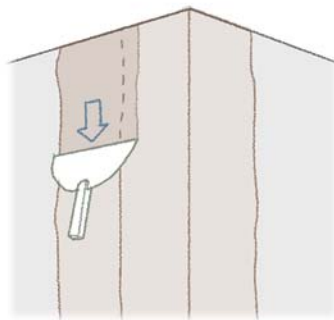

2 Once the bead is cleared, go over the compound on both sides using the same method as you used on the first coat.

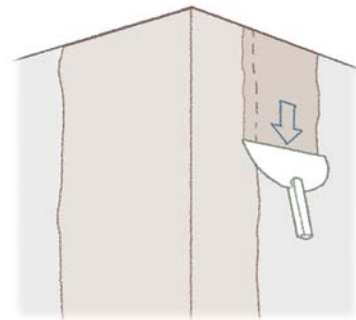

3 Bring the mud out an additional 4 in. to 5 in. on each side, and feather the outside edge.

Working with Mud

.....
 If you're new to drywall finishing, the following pointers should help you get started. But remember, finishing drywall is a skill that can be mastered only through practice.



1 Get something to hold the compound, such as a rectangular “mud pan,” a hawk, or a drywall trowel (shown here). These implements provide a flat surface for cleanly cutting off a workable portion of mud with a drywall knife. They also offer a straight edge, which can be used to scrape mud off the knife and to shape the mud on a loaded knife.

For spreading mud on flat surfaces (for tapered or butted seams), load the center of the knife and leave both sides clear. For spreading mud on inside corners, load one half of the knife (the side that will go into the corner) and leave one side clear.

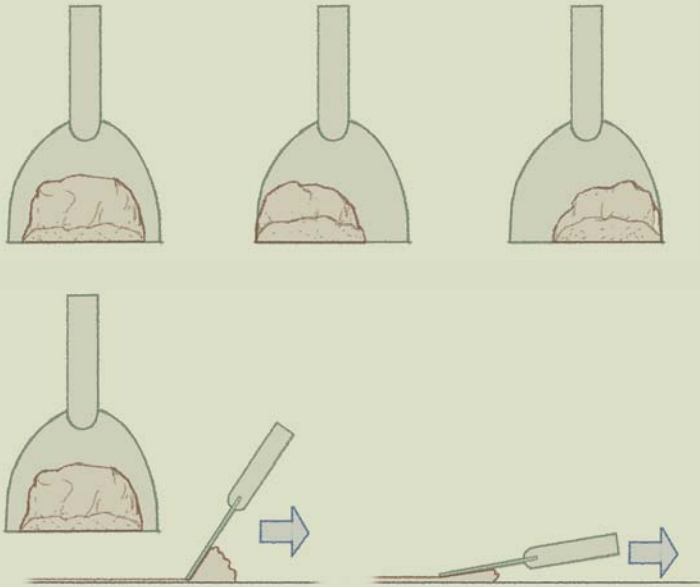

2 To avoid dropping mud as you apply it to the ceiling or wall, learn to load the knife correctly by leaving one or both sides of the knife free of compound.

6 It's important to hold the knife or trowel at the correct angle as you apply and smooth the compound. The angles are mostly learned by feel. As you work with a knife or trowel, experiment with different angles and note which ones work best for the particular job you're doing.

● THIRD COAT: FINISHING UP

Before starting the third coat, it's often a good idea to do some light sanding—especially if you're new to drywall finishing. Use 120-grit drywall sandpaper or sanding screen mounted on a pole sander. Concentrate on high spots, such as ridges and lumps, and ignore low spots, such as nicks and grooves. The low spots can be filled in with subsequent coats of mud. Sand parallel to the seams.

The third coat should be a light finishing coat that fills low spots, smooths the surface, and feathers and extends the outside edge.

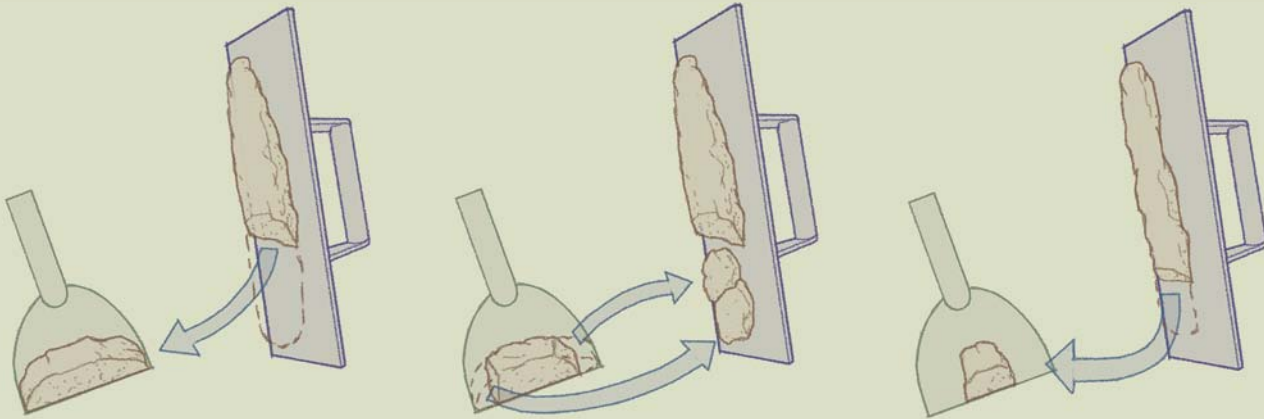

3 There are two ways to load up the knife with one or both sides clear of mud. The first is to cut off a workable portion of compound along the full length of the knife . . .

4 . . . and then use the edge of the implement to cut the mud off one or both sides.

5 The second method works best if you're using a trowel to hold the compound. Spread the mud in a line 1 in. to 2 in. wide along the edge of the trowel, then cut off a workable portion with the center or one side of the knife.

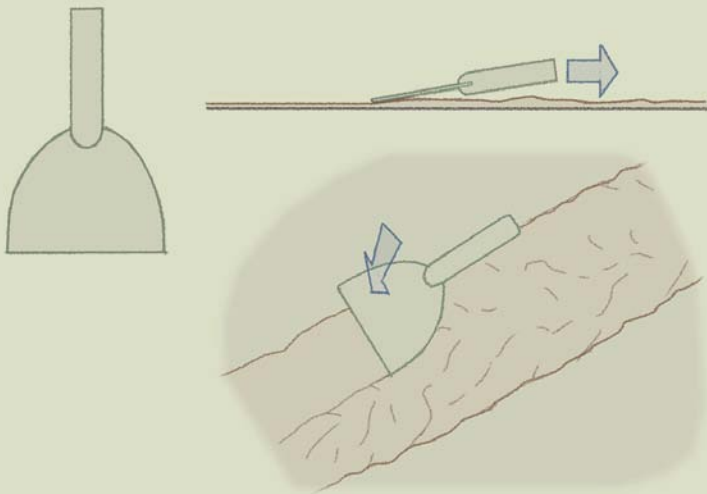

7 To blend the compound seamlessly with the paper surface of the wallboard, the finished areas have to be feathered along the outside edges. To achieve a feathered edge, hold the knife or trowel at a shallow (5° to 10°) angle as you pull it down the outside edge of the mud. At the same time, press the side that's outside the mud tight against the surface, and leave the side over the mud just off the surface.

Touching up After the third coat dries, go over the finished areas again. Look for thick edges, especially along the outside of the joints' edges, and any pits or grooves (see the drawing on p. 334).

Fill pits and other low points using the same technique described for filling the area over screw heads.

Sanding When the compound dries, put on a dust mask and sand the finished areas. Use 120-grit drywall sandpaper or sanding screen. When sanding the screw heads and the edges of the compound, be careful not to damage the paper by oversanding.

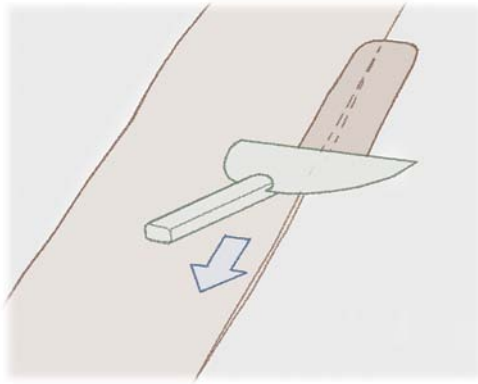

To taper a thick edge down, apply a small amount of compound along the outside of the edge. Hold the knife at about a 45° angle with one side riding the edge. Pull the knife parallel to the edge as you scrape up the excess mud. This leaves a tiny amount of mud beside the edge and tapers the compound down to a fine feathered edge.

TOP TIP

Apply Extra Coats and Reduce Sanding

There is no law that says drywall must be finished in three coats. You can eliminate imperfections in two ways: Sand them out or fill them in with a bit more mud. Before attacking the surface with sandpaper, consider doing a bit more touch-up. These coats are very thin and dry fast—and they usually yield a better job with less sanding.

Wood and Ceramic Tile

Although more expensive than drywall, wood and ceramic tile are both alternatives for ceiling and wall coverings. Wood is often chosen for its aesthetic impact and might be installed in just a few areas in the house. Ceramic tile is a durable, water-resistant material frequently used in bathrooms and other wet or damp locations (for more, see the section on flooring later in this chapter).

Wood Ceiling and Wall Coverings

Solid-sawn wood and man-made wood products are both used for ceiling and wall coverings. Both solid-sawn planking and plywood made to look like planking are options. In fine homes, architectural wood treatments, such as coffered ceilings and stile-and-rail panel systems, are used.

Installing solid-sawn tongue-and-groove plank paneling

Planks are usually set perpendicular to supporting members of the frame and held in place by one nail per support. The nail, which is driven at an angle through the tongue, is covered by the grooved edge of the next board installed. For ¾-in. panels, use 6d finish nails if you're driving them by hand; when using a nail gun, use 2-in. 15- or 16-gauge nails.

If you want to run this kind of paneling parallel to the framing member, as would be the case when running wall paneling vertically, you have to install sleepers first.

Solid-wood tongue-and-groove paneling is subject to expansion and contraction. For this reason, let the wood acclimate inside for a few days before installation, and leave room around the perimeter of the ceiling or wall to allow for expansion during periods of high humidity. Most of the expansion takes place across the width of the planks. This gap is typically covered by molding.

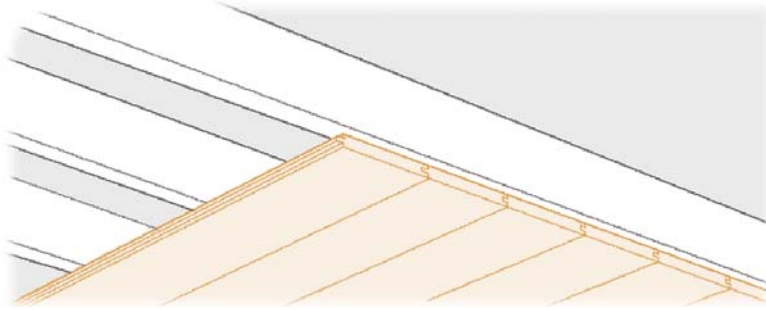

Solid-sawn tongue-and-groove planking can be installed on ceilings in the same way hardwood flooring is installed.

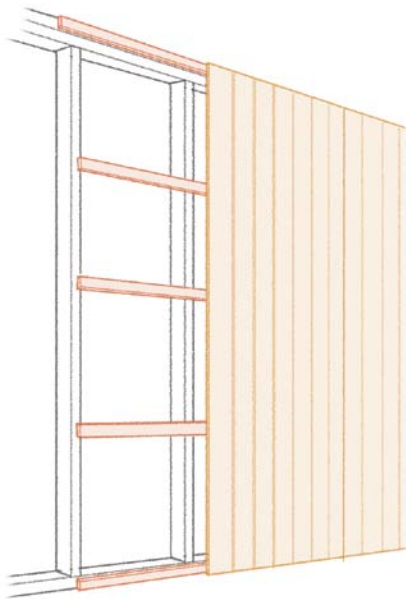

If you want to run solid-sawn tongue-and-groove paneling parallel to the framing member, as would be the case when running wall paneling vertically, you have to install sleepers first.

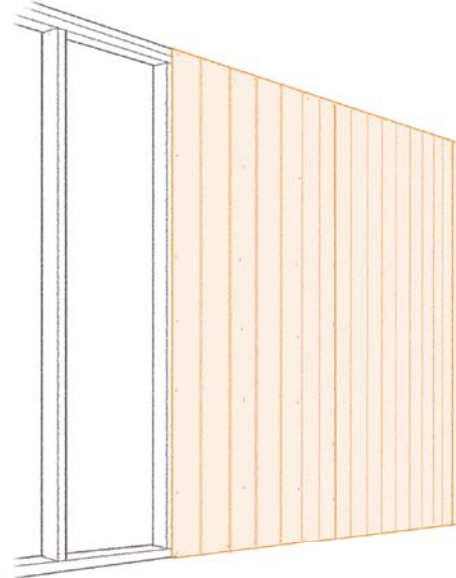

Plywood made to look like tongue-and-groove planks goes up quickly.

Installing plywood paneling Plywood paneling looks a lot like solid-sawn paneling when it's installed on 8-ft.-high walls or on ceilings less than 8 ft. wide. In taller walls or wider ceilings, however, the seams at the ends of the panels give away the fact that it isn't made of individual planks.

Plywood paneling is dimensionally stable, so placing the material inside the house prior to the installation is not essential. Nail the panels to the frame in the same basic way that drywall is attached to the frame. Use 6d casing or finishing nails if you're hand nailing; use 2-in. 15- or 16-gauge finish nails if you're using a nail gun. The indentations from the nails can be filled with putty afterwards.

Plywood paneling should be installed with the long dimension perpendicular to the framing members or furring strips. All edges must be nailed to solid framing or furring strips. A typical nailing schedule is every 6 in. around the perimeter and every 12 in. on each supporting member in the field.

Floor Coverings

No single material dominates the floor-covering market the way dry-wall dominates walls and ceilings. The four most common options—wall-to-wall carpet, sheet vinyl, wood, and ceramic tile—all have sizable chunks of the market. In addition, there are many less-common materials that people use either to save money or to make an architectural statement. Among them are linoleum (tiles and sheet goods), vinyl tile, vinyl and laminate floating floor systems, cork, and masonry (brick, stone, and concrete).

Floor coverings are usually installed by special-trade contractors, many of whom work with a single material. They have the tools and skills to do the job quickly and correctly, and they typically sell the material and the installation together. This helps contractors manage their schedules while controlling costs and quality. Whether you choose to work with subcontractors or do the job yourself, it's important to know the strengths and weaknesses of the materials and the best ways to install them.

Wood Floors

Today, there are two basic wood floor systems: solid planks and engineered flooring. Solid flooring comes finished or unfinished. Engineered wood flooring is made of multiple plies of wood glued together like plywood. The top layer, usually a layer of hardwood, is called the wear layer. Engineered flooring doesn't need sanding or finishing after installation.

The installation of either solid-wood or engineered floors is well within the abilities of most carpenters, and the only special tool required is a flooring cleat nailer (which costs between \$100 and \$300). For these reasons, many builders and remodeling contractors install wood floors themselves. It is also a common job for advanced do-it-yourselfers.

This section covers the installation of the most common type of wood flooring, 3/4-in. by 2 1/4-in. tongue-and-groove strip flooring. With some minor adjustments, the procedure discussed here can be applied to other sizes of both unfinished and nailed engineered flooring.

Estimating what you'll need Calculate the square footage and add 6% for waste. If you're using 2 1/4-in. strip flooring, you'll need about eight flooring cleats or staples per sq. ft. For every 400 sq. ft. of floor covering, you'll need one roll of #15 tar paper.

Preparing the house and material Bring the wood flooring to the house three days before the installation, and maintain the heat or air-conditioning at a comfortable level. Clean the subfloor thoroughly, and nail down or remove any protruding nails or staples.

TOP TIP

Do the Floors Last

Installing floors should be one of the last jobs done in the house. Builders delay the installation of floor coverings for a practical reason. Before finish floors are down, they can drop drywall compound, splatter paint, drag benches and ladders into place, and set their tools and materials on the subfloor. Any damage will soon be covered. Being able to do this speeds up the job and minimizes problems with the finished floor.

Solid-lumber flooring can be refinished many times.

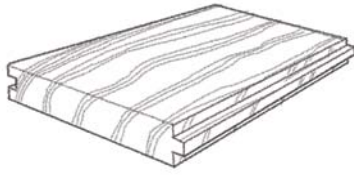

The wear layer on engineered wood flooring is relatively thin and can only be refinished a few times.

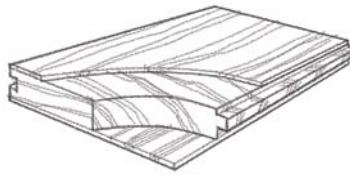

Remove doors, and trim the bottoms of the door jambs. If you use a power saw, set the height just above the estimated height of the top of the finished floor. If you use a manual saw, set the saw on top of a scrap of the flooring, and use it as a guide to trim the bottom of the jamb. Although not as easy as using a manual undercutting saw, you can also use a standard handsaw or a Japanese pull saw along with the scrap.

Decide on how the floor will run Solid-wood flooring is usually laid out perpendicular to the joists, which helps to stiffen the floor. If you have to run the boards parallel to the joists, you may need to add a layer of underlayment to stiffen the subfloor.

In general, a $\frac{3}{4}$ -in. plywood or OSB subfloor is sufficient when $\frac{3}{4}$ -in. wood flooring is perpendicular to floor joists that are installed 16 in. on center. A combined subfloor thickness of $1\frac{1}{8}$ in. is recommended when the wood flooring is run parallel to the joists. In new houses and additions, this thickness is typically achieved by adding a $\frac{1}{2}$ -in. layer of APA-The Engineered Wood Association (APA)-rated underlayment. If you plan to run the flooring parallel to the joist, check with the flooring manufacturer to verify its requirement.

STEP 1 Install tar paper

Make sure the subfloor is clean and dry before you install the tar paper.

1 Mark the locations of the joists (apparent by the nailing pattern in the subfloor) on the wall.

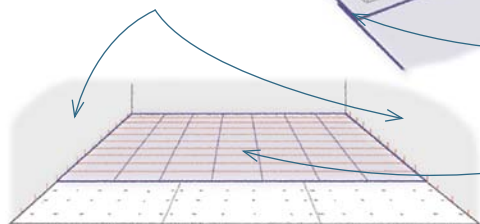

2 Cover the subfloor with #15 roofing tar paper. Overlap the rows 2 in. and fasten with $\frac{1}{4}$ -in. staples. Use only enough staples to hold the tar paper in place.

3 Transfer the marks on the wall to the floor. Snap chalklines between these marks to indicate where the floor joists are.

TOP TIP

Strip and Plank Flooring

Wood flooring that's $3\frac{1}{4}$ in. or less in width is usually called *strip flooring*. Wood flooring wider than $3\frac{1}{4}$ in. is usually called *plank flooring*. Strip and plank flooring are installed the same basic way.

Carpet Basics

Carpet is the single most popular floor covering, typically installed by subcontractors. Carpet is manufactured in very long rolls, which are cut to length by retail suppliers. The rolls come in three basic widths: 12 ft. (the most common), 13½ ft., and 15 ft. It usually makes sense to let the width of the main rooms in the house influence your choice of carpet. If you have a couple of rooms that are 14½ ft. wide, for example, try to find a carpet that's available in 15-ft. widths.

STEP 1 Clean the floor

Remove doors, scrape up all lumps of drywall mud and construction adhesive, and remove staples and nails (or pound them flat). Sweep and vacuum thoroughly.

STEP 2 Install tackless strips and pad

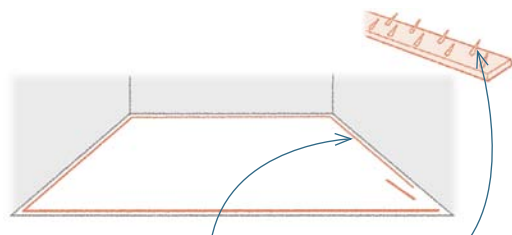

- 1 Place strips about ½ in. from the face of the baseboard.
- 2 Make sure pins face the wall.

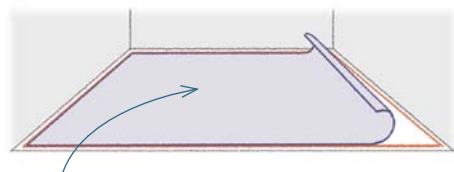

- 3 Install the carpet pad inside the framework of the tackless strips. Padding is typically attached with an electric staple gun, with one staple every 8 in. or so. Seams should be butted and not overlapped. Seams are held together with tape (typically, duct tape).

STEP 3 Cut and fit the carpet

Measure the rooms and determine where to locate seams, if any. Cut the carpet into pieces a few inches larger than the rooms, with the pile running consistently in the same direction.

Three basic widths

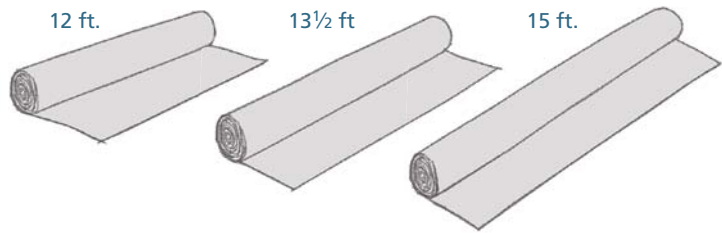

STEP 4 Seam the pieces

Cut mating edges carefully, and put a strip of seaming tape under the seam. Use a seaming iron to melt the glue, and press the carpet just behind the iron as you advance. It's a delicate process that requires precision and timing.

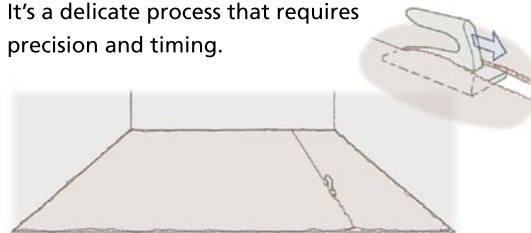

STEP 5 Stretch, hook, and trim

After the seams dry, use kickers and stretchers to pull the carpet taut, then press the edges onto the pins of the tackless strips. After the carpet is hooked on the pins, use a knife to trim the edges along the wall, leaving about ½ in. extra.

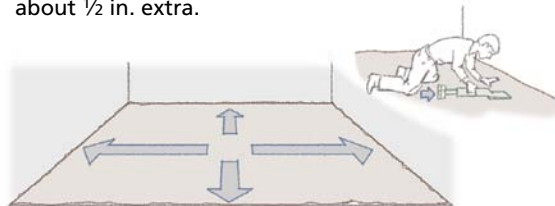

STEP 6 Tuck the edge

Tuck the excess into the space between the wall and the tackless strips.

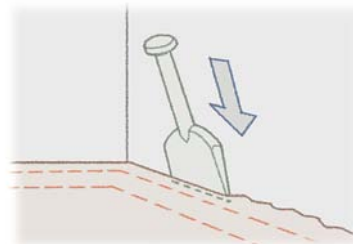

STEP 2 Mark a baseline

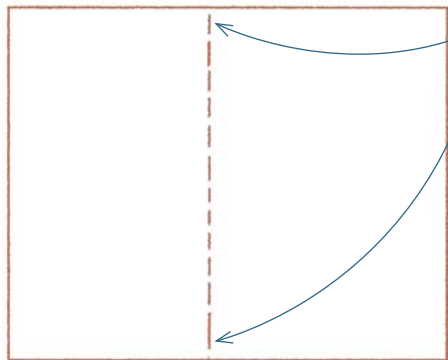

1 Measure the same distance from each end of the wall from which you intend to start the flooring to a point near the center of the room, and mark the floor.

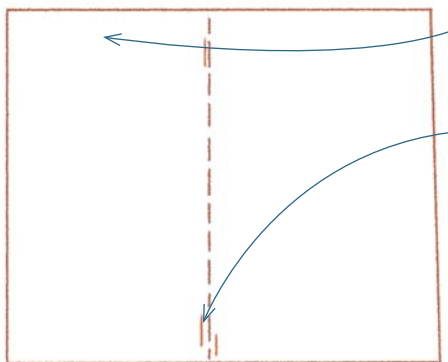

2 Measure the distance from one of the marks to the opposite wall.

3 Measure and mark the same distance from the opposite wall toward the second mark.

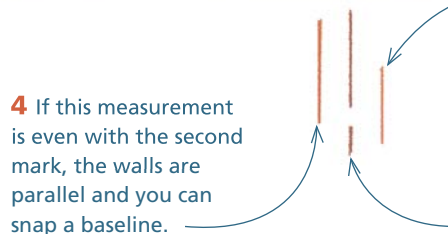

4 If this measurement is even with the second mark, the walls are parallel and you can snap a baseline.

5 If the measurement does not land evenly with the second mark, the walls aren't parallel.

6 Mark the halfway point between the first mark and the mark you just made. Now snap the baseline from the middle mark to the single mark at the other end of the room. This baseline evenly divides the amount that the walls are out of parallel.

TOP TIP

Make Room for the Expansion Gap

.....
If you plan to use hardwood flooring, think ahead when you're installing the drywall and baseboard. Hold both the drywall and the baseboard up at least $\frac{3}{4}$ in. off the floor. This allows flooring to go under the baseboard and still have plenty of room to expand due to changes in relative humidity.
.....

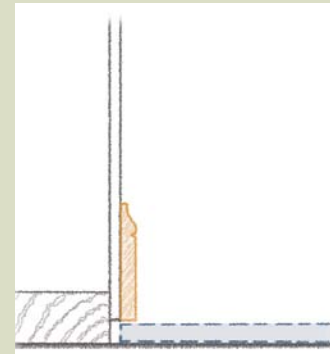

STEP 3 Lay out the first strip

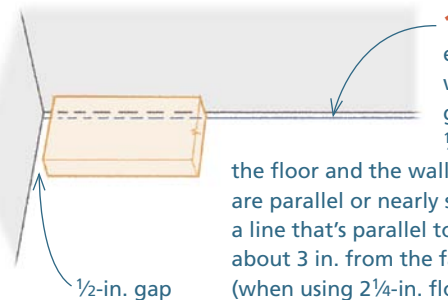

1 To allow for expansion of the wood, leave a gap of at least $\frac{1}{2}$ in. between the floor and the wall. If the walls are parallel or nearly so, simply strike a line that's parallel to your baseline about 3 in. from the face of the wall (when using $2\frac{1}{4}$ -in. flooring).



2 If the walls are not parallel, measure and mark from the baseline.

3 This starting line will run at a slight angle in respect to the wall. If you've held the drywall and base up off the floor (see Top Tip

above), you'll have about $1\frac{1}{4}$ in. of space under these materials. In some cases, however, you'll have to taper-cut the first floorboard to meet the twin requirements of running parallel to the baseline and fitting along the wall with the $\frac{1}{2}$ -in. gap.

STEP 4 Install the first few strips

1 Orient the first strip with the tongue facing the inside of the room and the outer edge of the tongue even with the line.

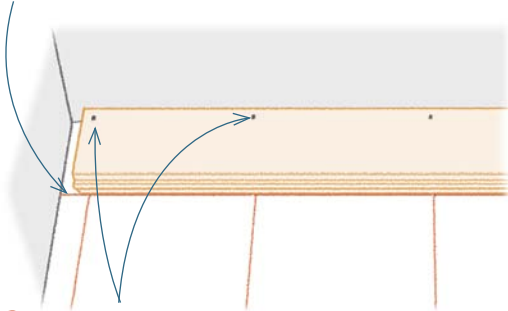

2 Face-nail the first strip to anchor it along the line. Be careful to keep the strip on the line as you nail it off. Place a nail every 8 in. and in every joist. (The locations of the joists should be marked by chalklines on the tar paper.)

3 Go back and blind-nail the first strip by nailing at an angle through the tongue. Don't drive these nails all the way in to avoid damaging the edge of the strip.

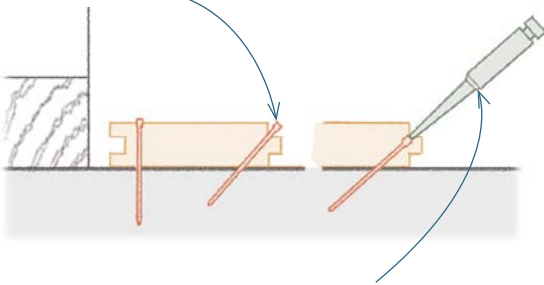

4 Use a nail set to drive in the last 1/8 in. of the nail.

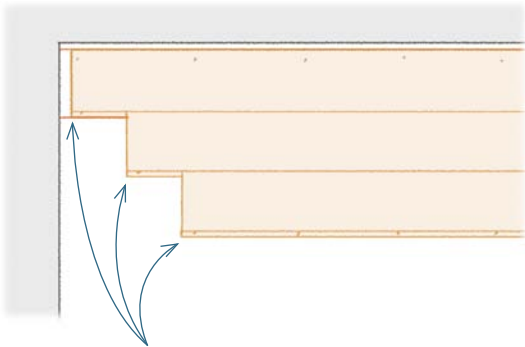

5 The ends of the floorboards in each row should offset the ends of the boards in adjoining rows by at least 3 in. Begin the second row with at least this offset, and blind-nail the strips. The second and third rows usually have to be nailed by hand because of the difficulty of fitting a nailer against the wall.

STEP 5 Lay the rest of the floor

After two or three courses, you'll have enough room to use the flooring nailer. For each row, select strips that leave the minimum 3-in. offsets. Use the mallet to tap each piece tight into the groove of the preceding row and tight at the end to the last piece installed.

When you get to the end of the row, cut the last piece to length. Since you should leave a gap at the end of the floor, this is not a precise cut.

1 Set the piece in place upside down.

2 Use your finger as a gauge for the gap at the wall.

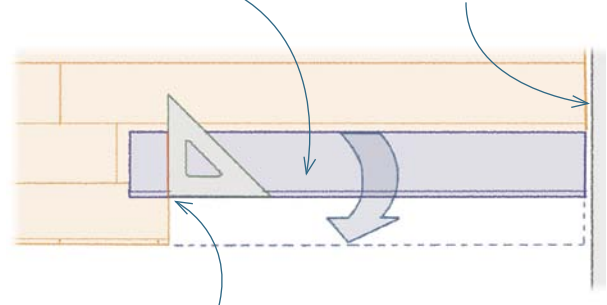

3 Mark the other side end even with the end of the last piece installed. Cut at the mark. The best tool for making these cuts is a small miter saw.

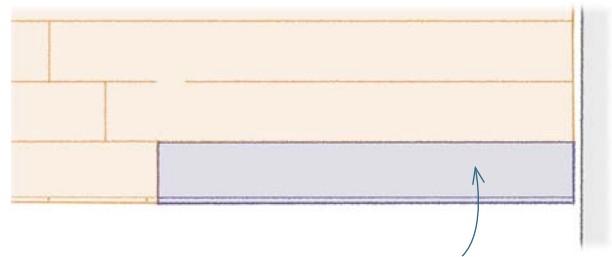

4 Place the strip right side up and nail it in place. To save time, installers lay out several rows at the same time, a process called racking. While racking several rows at once is not essential, it's a good practice that saves time and energy.

STEP 6 Finish up

At the far end of the floor, the opposite wall interferes with the nailer, so you have to face-nail the last few rows.

TOOLS & TECHNIQUES

Using a Floor Nailer

There are two types of floor nailers: manual and pneumatic.

To use a manual nailer, you deliver a sharp blow or blows with a mallet to the head of a ram, which drives the floor cleat into the wood. A pneumatic nailer also is actuated by smacking the ram with a mallet. But in this case, the blow opens a valve, allowing a burst of compressed air to drive the ram against the cleat.

Both of these nailers have a plate that fits snugly over the tongue of the board and both drive the nail at the correct angle (usually 45°), in the right location and to the correct depth. Many nailers can use floor staples in lieu of cleats. Although the manual nailer takes more energy to use, it works as well as the pneumatic nailer.

Nailers typically come with a special-purpose mallet. And manufacturers usually offer accessory shoes for fastening floors with thicknesses other than $\frac{3}{4}$ in. and for face nailing. If you plan on installing prefinished wood, use a nailer with a mar-resistant plate.

WAYS OF WORKING

Floating Floor Systems

In recent years, a new kind of wood floor system, called the floating floor, has been introduced by several manufacturers. Although solid wood is used in a few of these systems, most are made from prefinished engineered wood.

As the name suggests, the floors are not nailed or stapled to the subfloor. Rather, they're simply set on a special cushioned underlayment. The edges and ends of the boards are glued or locked together mechanically, and the whole system floats over the subfloor. The main advantage to this system is that it is forgiving of flaws and movement in the subfloor. It's also easy to install and requires no special tools. For these reasons, it's often marketed as a do-it-yourself product.

Non-wood floating floors

In addition to engineered wood floating floor systems, there are two other floating systems that are made from materials other than wood. These include laminate flooring systems and vinyl flooring systems. These systems are installed like wood floating floors and work the same basic way.

The details of installing floating floors vary with the product used. It's essential, therefore, to read the specific guidelines that are provided by the manufacturer of the floor you're installing.

Sheet Vinyl Basics

Sheet vinyl flooring accounts for about 12% of the market in the United States, second only to carpet. It's similar to carpet in several respects. Like carpet, it's delivered to retail suppliers in very long rolls, then it's cut and sold by the running foot. Suppliers often offer a package deal that includes installation.

Standard widths are 6 ft. and 12 ft. When seams are required, they should be placed in inconspicuous locations whenever possible. Sheet vinyl often has a pattern, so the offset required to keep the pattern true must be taken into account any time a seam will be necessary. Keep that in mind as you estimate how much material you'll need.

Two ways to glue down vinyl

Sheet vinyl may be fully adhered or perimeter bonded. Most vinyl flooring is designed for one or the other system. Make sure you know which method is specified. Either system can result in an attractive, durable floor.

A fully adhered floor has adhesive applied under the entire sheet. The process is more time consuming and difficult, and the underlayment must be nearly flawless. But fully adhered floors feel more solid underfoot, and they tend to last longer.

If the floor has a seam, the vinyl is bonded along the seam first. The installer typically folds one half of the floor back and tapes it to hold it out of the way. Using the edge of the vinyl that's still on the floor as a guide, the installer then marks the location of the seam on the underlayment.

Apply adhesive with a notched trowel (use the adhesive and notch size recommended by the vinyl manufacturer). Fold the vinyl back over the adhesive, then repeat the process on the other half of the sheet. Embed the vinyl with a 100-lb. roller.

A perimeter-bonded floor should have only a 4-in. to 8-in. swath of adhesive applied at the seam and around the perimeter of the room. Seams should be bonded first, followed by the perimeter. If the edges will later be covered by baseboard and shoe molding, the edges are sometimes anchored with small nails.

Perimeter-bonded systems are easier to put down and more forgiving of defects in the underlayment, but they're more prone to coming loose and buckling.

STEP 1 Prepare the floor and the vinyl

Bring all materials into the house a few days before the installation, and maintain indoor temperatures between 65°F and 100°F. Subfloors must be clean and dry. Mop the floor to remove any dust, which can prevent a good bond from the adhesive, and let it dry completely.

Remove any doors that have been installed, and cut the bottoms of the door jambs so the underlayment and the vinyl can slide under. This can be done with a hand or electric saw (specialty floor-covering tools are available from Crain Tools).

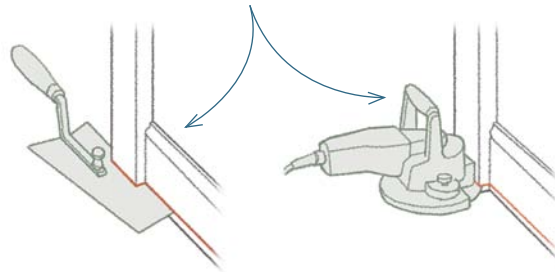

STEP 2 Install the underlayment

Install a new layer of underlayment (typically ¼ in. thick). Use panels that are APA-rated for underlayment. Installers usually use an electric stapler with 1-in. underlayment staples. Ring-shank nails (1 in. to 1¼ in. long) are an acceptable alternative. The fastening schedule is every 3 in. along the edges and every 6 in. in both directions in the field of the panel.

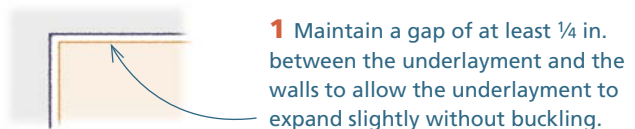

1 Maintain a gap of at least ¼ in. between the underlayment and the walls to allow the underlayment to expand slightly without buckling.

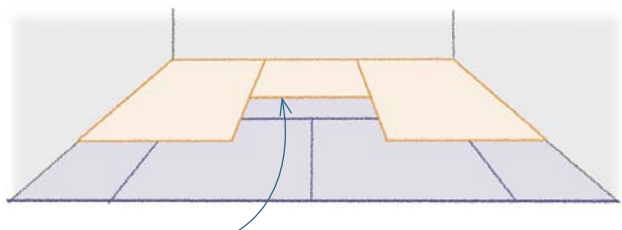

2 Offset joints between sheets of underlayment from seams in the plywood subfloor.

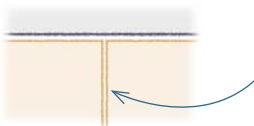

3 Leave a ½-in. gap between the edges.

STEP 3 Fill seams and defects

The seams and any defects in the panels should be filled with a floor-leveling compound (such as Level-Best® Floor Leveler or Dap Presto Patch®). After troweling on the compound and allowing it to dry, sand the compound smooth. The underlayment must then be thoroughly cleaned.

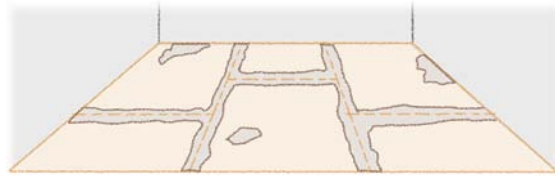

STEP 4 Cut and fit the vinyl

After measuring the room or rooms and planning the location of seams, vinyl installers either make a template of the floor or they cut the sheet (or sheets) slightly larger than the room.

1 To make a template, bring red rosin paper or roofing felt to within about 1 in. of the walls, cabinets, and other boundaries.

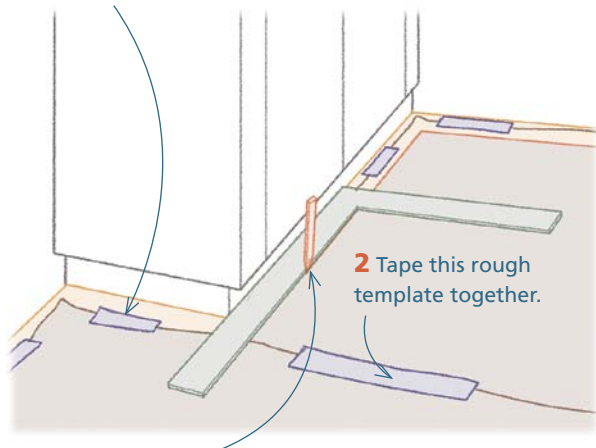

2 Tape this rough template together.

3 Use a framing square to mark a precise 2-in. offsetting line inside the boundaries. For edges that aren't straight, use a divider set to 2 in. Carefully roll up the template.

4 On a large, clean surface, unroll the vinyl sheet and place the template on top.

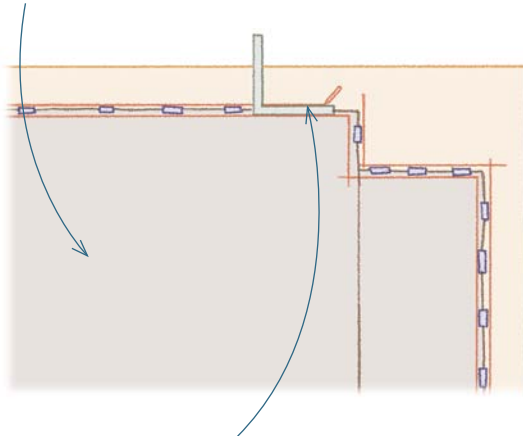

5 Align the framing square on the lines on the template to mark the lines to cut the vinyl. Cut the sheet precisely along the line.

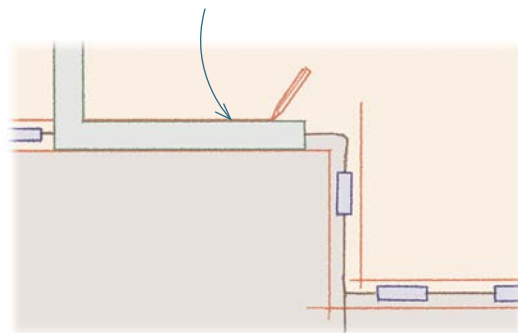

STEP 5 Or cut in place

If you cut the vinyl large, fold the edges up on the walls and trim them in place as the sheet is installed.

STEP 6 Double-cutting seams

As in carpet installation, the cutting and joining of seams is the most challenging part of installing vinyl sheet goods. Vinyl installers begin by overlapping the two pieces so that the pattern is exactly aligned. Using a knife equipped with a new blade and a steel straightedge, they cut through both sheets at the same time—a process called double-cutting.

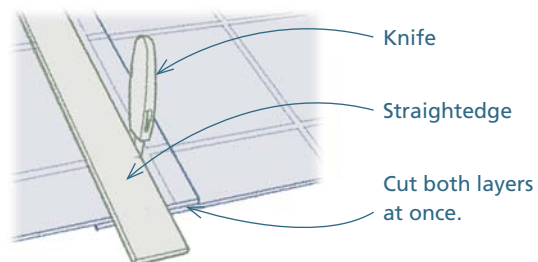

Installing Ceramic Tile

Prior to the 1980s, quality tile jobs could only be achieved with a wet mortar base, which required troweling skills that few carpenters possessed. In addition, equipment for sawing tile was prohibitively expensive.

In the last few decades, both of these barriers have been broken. Tile backer board, such as HardieBacker®, Durock®, and DensShield®, has largely replaced mortar bases. And modestly priced tile saws equipped with diamond blades have greatly reduced the cost of cutting tile. Tilesetting is now far more accessible to carpenters—and to anyone who’s comfortable working with tools.

There are two structural considerations for a tile floor: how much bounce is in the floor you’re starting with, and how thick the subfloor should be underneath the tile.

• WHAT GOES INTO A TILE FLOOR?

Ceramic tile must be installed as a system that includes the base or substrate, an adhesive to bond the tile to the substrate, and the grout used to fill the joints between the tiles. In some circumstances, one or more membranes are included. Details vary according to the conditions and the budget.

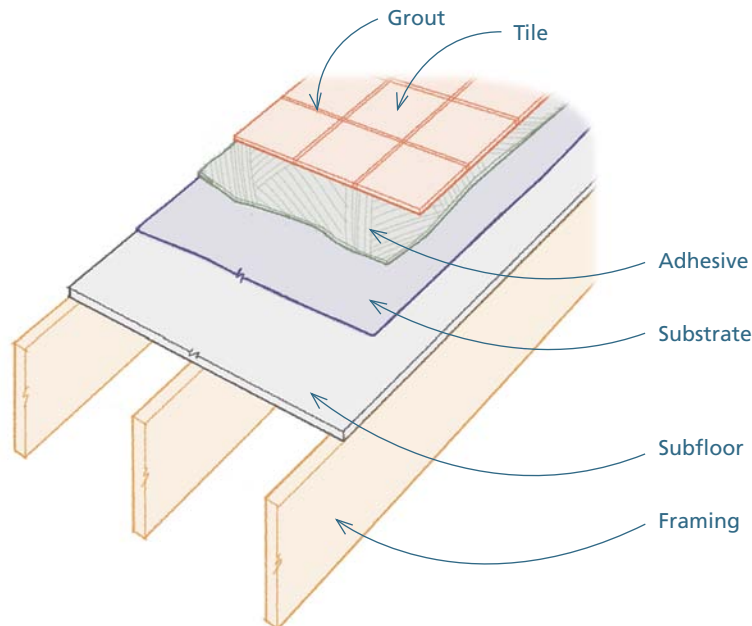

● CUTTING BACKER BOARD

Backer board can be cut and snapped, like drywall. But this can be difficult with backer boards that are cement based.

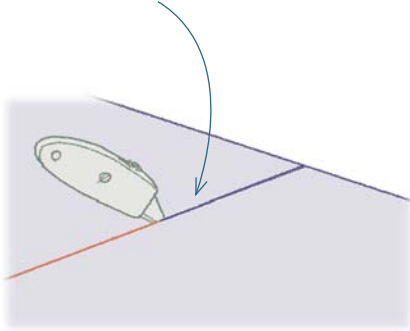

An alternative is to use a 4½-in. mini-grinder equipped with a diamond blade. While this tool cuts quickly, it creates a lot of dust. Try to make the cuts outside, and always wear goggles and a good dust mask.

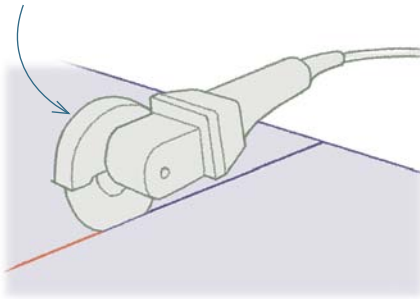

● INSTALLING BACKER BOARD ON WALLS

Backer board can usually be installed with galvanized roofing nails or screws designed for backer board (such as Backer-On™ screws).

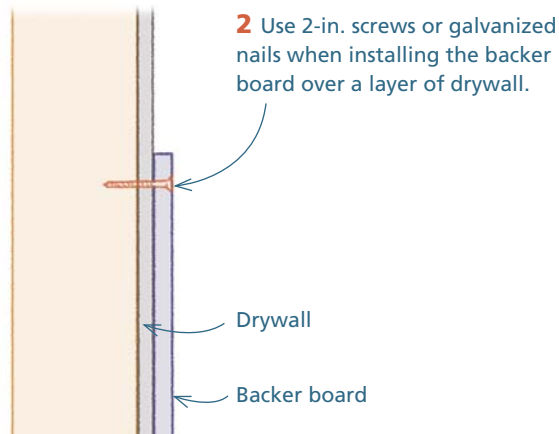
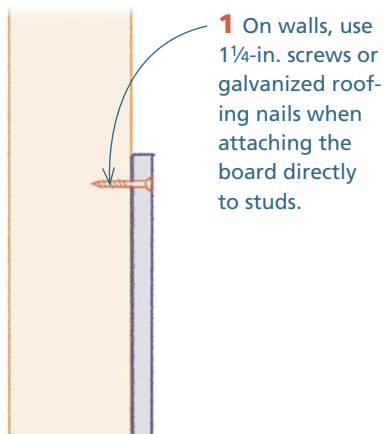

3 Blocking is generally required along factory edges when studs are 24 in. on center but not when framing is 16 in. on center.

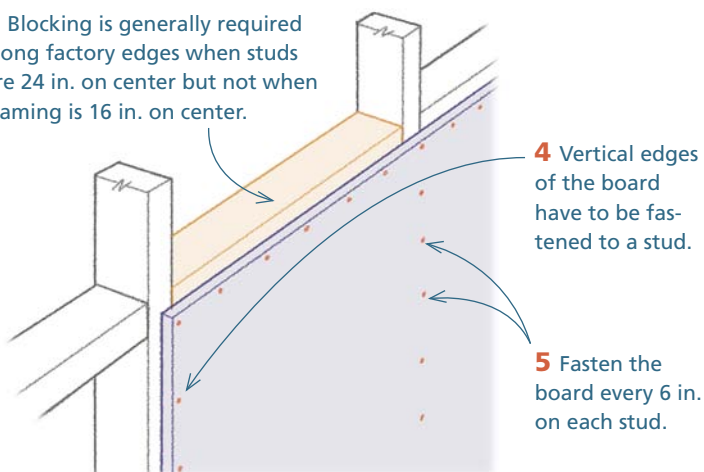

Membrane Options

Membranes isolate tile from the underlying structure and waterproof the area under the tile. Isolation membranes are used to prevent cracks from differential movement between the substrate and the tile. Waterproofing membranes are used in wet locations to prevent leaks and inhibit the growth of mold and mildew. Some membranes do both.

In the past, waterproofing membranes were installed under the tile substrate, but newer systems go over the substrate and the tile is set directly on them. This is an improvement because there's less space for water to collect under the tile.

Membranes come in two forms. Liquid membranes, such as Pro-Shield and DuroSET, are painted on with a brush or a roller. Sheet membranes, such as Schluter®-DITRA and Schluter-KERDI, are adhered with special adhesives or thinset.

● INSTALLING BACKER BOARD ON FLOORS

1 Spread a layer of latex-modified thinset mortar over the subfloor with a 1/4-in. square-notched trowel. To prevent the mortar from skimming over (drying on the surface), spread only enough mortar for one sheet at a time.

2 Lower the backer-board panel into the mortar, and install 1 1/4-in. roofing nails or backer-board screws every 8 in. in both directions.

3 Leave a gap of at least 1/4 in. around the perimeter of the floor for expansion.

4 Leave a 1/8-in. gap between backer-board panels.

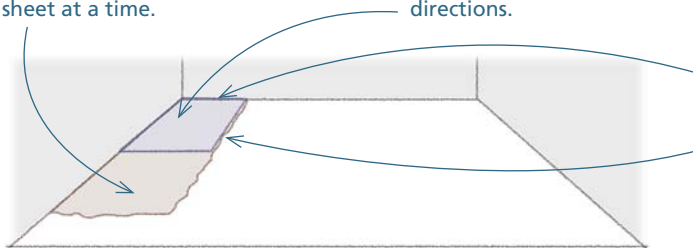

5 On both walls and floors, fill joints between pieces of backer board with thinset mortar. This includes inside and outside corners.

6 Cover the seam with alkali-resistant fiberglass tape.

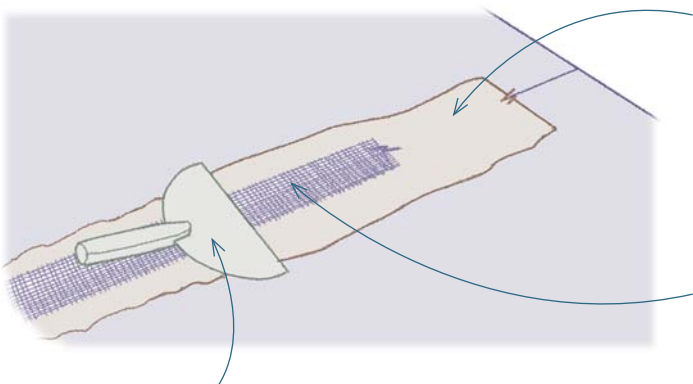

7 Smooth out the mortar with a 6-in. drywall knife.

• LAYING OUT TILE

The goal in laying out tile is to maximize the size of the cut tiles around the perimeter of the room while maintaining a symmetrical layout. That is, you want cut tile of equal widths on each side of the room. Tile spacing is established for each axis of the room.

To center tiles across the width:

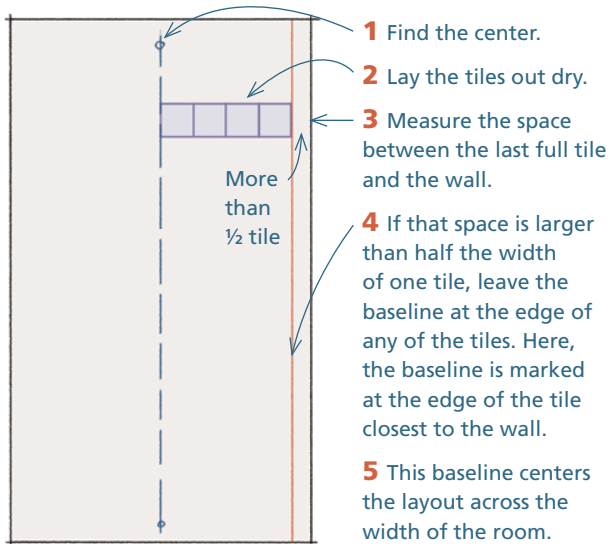

To center tiles along the length:

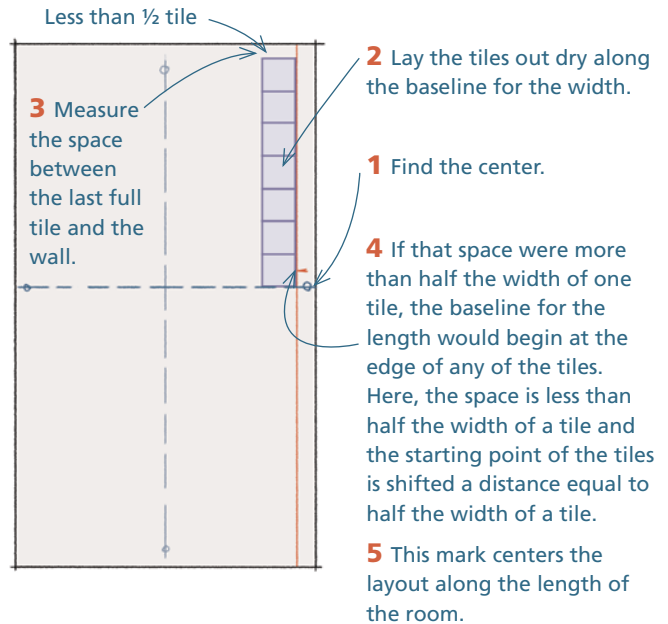

To set second baseline perpendicular to the first:

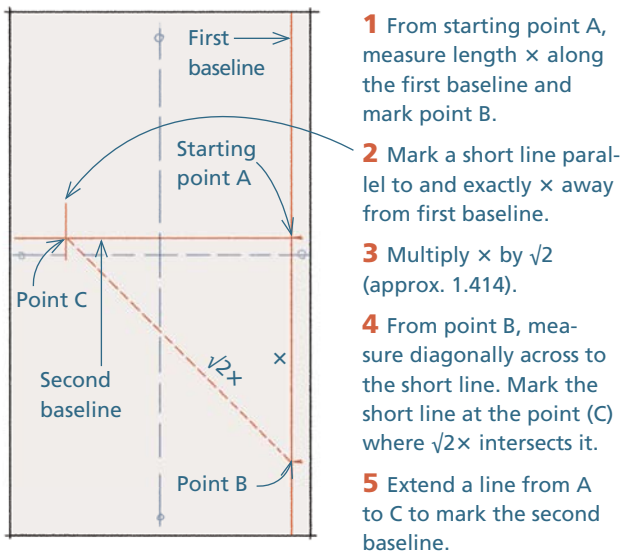

Completed tilework:

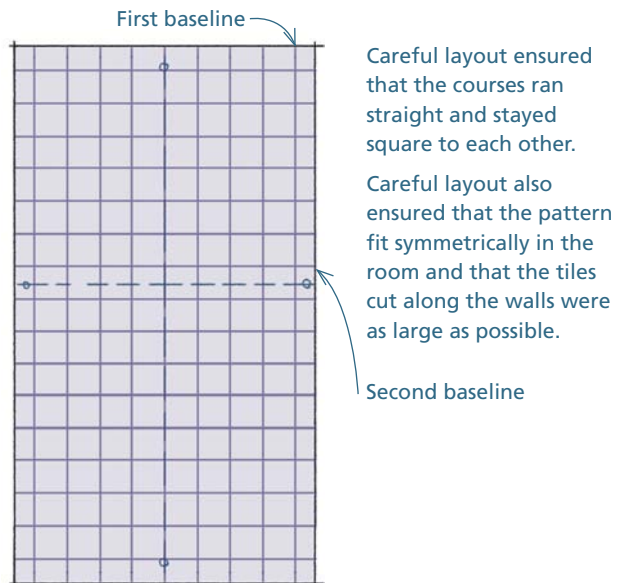

● LAY OUT A PERPENDICULAR LINE

To begin laying tile, you need a layout line perpendicular to the first. Where these two lines meet is the spot where you'll start to lay tile. For small layouts, you can use a framing square to create a perpendicular reference line.

For a large floor, however, the following procedure is more precise:

1 Mark the desired point on the baseline at which you want to lay out the perpendicular line. In this example, this is A.

2 Measure and lay out a parallel line near the wall. The exact distance is not important, but the second line should be precisely parallel to the first. It's easier if you use a distance that's in full inches. In this example, the distance is 60 in.

3 Measure and mark the same distance (60 in.) along the baseline, starting at the beginning point on the baseline. The second mark is B. Now find the hypotenuse of a right triangle with two sides that are 60 in. The formula is $\sqrt{2} \times 60$. This comes to 84.85 or $84\frac{7}{8}$ in.

4 From point B, measure diagonally across to the parallel line. Swing the tape measure until the $84\frac{7}{8}$ -in. dimension intersects with the line, and mark the second line at C.

5 Snap a perpendicular line from A to C.

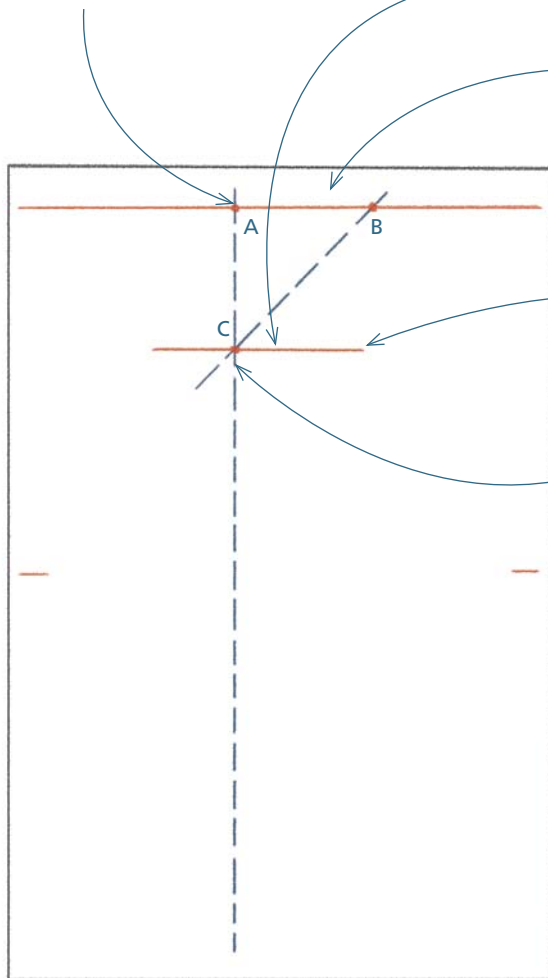

TOP TIP

Don't Tile Yourself into a Corner

.....
Before you strike the layout baseline, think about how you'll bring the material into the room and how you'll work your way out. Mark both the baseline and the perpendicular control line across the room from the most convenient door.
.....

WAYS OF WORKING

What's under the Tile

.....

The Tile Council of America, among others, specifies a maximum deflection of $l/360$ in a floor that will be tiled (that's the span divided by 360). This works out to roughly $\frac{3}{8}$ in. over 12 ft. Few builders actually measure this. Most builders and tilers use a rule of thumb that says if you can feel the floor bounce, you need to stiffen it up.

When you use concrete backer board (which this book recommends), you need an underlayment that's rated Exposure I and at least $\frac{5}{8}$ in. thick. In new construction, this is no problem because most houses are built with $\frac{3}{4}$ -in. underlayment, rated Exposure I.

In remodeling jobs, of course, you have to deal with existing conditions. In houses built before the 1960s, the subfloor is usually solid-sawn wood planking installed on the diagonal. The ideal thing to do is take up the subfloor and replace it with $\frac{3}{4}$ -in. tongue-and-groove plywood. This is not as easy as it might seem at first glance. A practical alternative is to patch and tighten the plank subfloor, then go over it with $\frac{5}{8}$ -in. or $\frac{3}{4}$ -in. Exposure I underlayment.

In houses built in the 1960s and 1970s, builders often used $\frac{1}{2}$ -in. underlayment. Then after the walls were built on this layer of underlayment, they installed a second layer of plywood or particleboard within the wall plates. In these cases, the best solution is to take up the top layer and replace it with $\frac{5}{8}$ -in. or $\frac{3}{4}$ -in. Exposure I plywood underlayment.

Setting Tile

There are two kinds of adhesives used to bond tile to its substrate. Organic mastic comes premixed in a bucket. It's easy to spread on the wall and has good "grab," meaning that once tiles are set, they tend to stay put. Thinset mortar, which is portland cement based, must be mixed on site. It's a bit harder to work with, especially on vertical surfaces where tiles have a tendency to slide down. Despite these problems, thinset is worth the extra effort; it's stronger and more durable than organic mastic.

Adhesive is applied with a notched trowel. Different-size notches are recommended for different tiles. Generally, the larger the tile, the larger the notch needed. Notch sizes are specified by the tile manufacturers and are usually printed on the boxes that the tile comes in.

Ceramic tile should never be installed over surfaces that are dimensionally unstable, such as solid wood or fiberboard. Tile can be installed over drywall or plywood, but substrates designed specifically for tile are usually better choices. These include cement-based products, such as WonderBoard®, HardieBacker, or Durock, and gypsum-based products, such as DensShield.

Cutting Tile

Although some tilers still use a score-and-snap cutter to make straight cuts in tile, the tile saw is now the standard tool. You can buy a small sliding-table tile saw equipped with a diamond blade and a watering system for less than \$100. The watering system helps keep the dust down and prolongs the life of the blade.

To make a straight cut, set the tile against the fence of the saw, and slide it through the spinning blade. Most saws have fence stops, which you can use to make repetitive cuts of the same dimension.

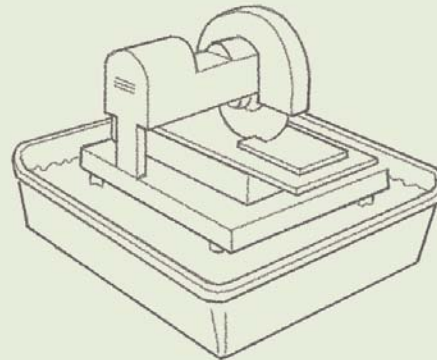

For curved cuts or right-angle cuts (which are often needed when tiling around a corner), use a 4½-in. grinder equipped with a dry-cutting blade. You can often start the cut with a tile saw and complete it with the grinder.

● SETTING TILE

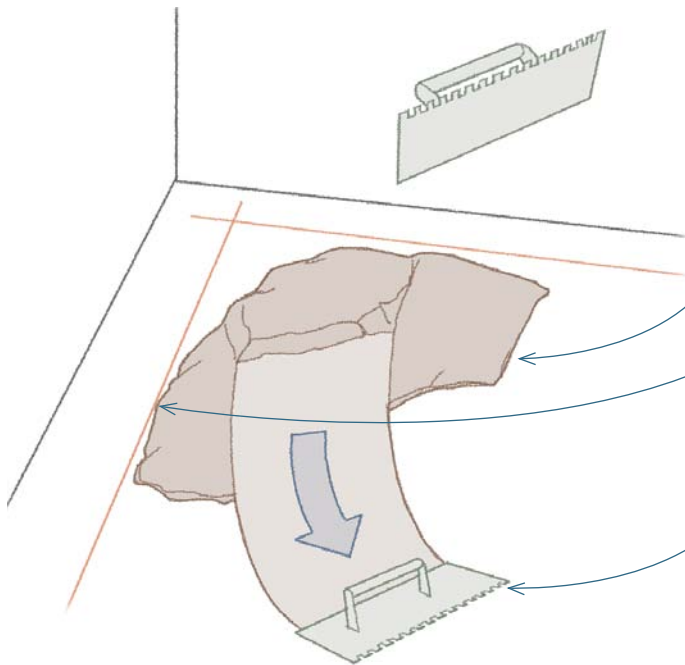

1 Dump a pile of mortar on the floor, and use the smooth edge of the notched trowel to spread the mortar over the surface.

2 Keep the mortar just off the layout lines, and avoid spreading so much mortar that it will skin over before you set the tiles in it.

3 Hold the trowel at about a 30° angle as you spread the mortar out.

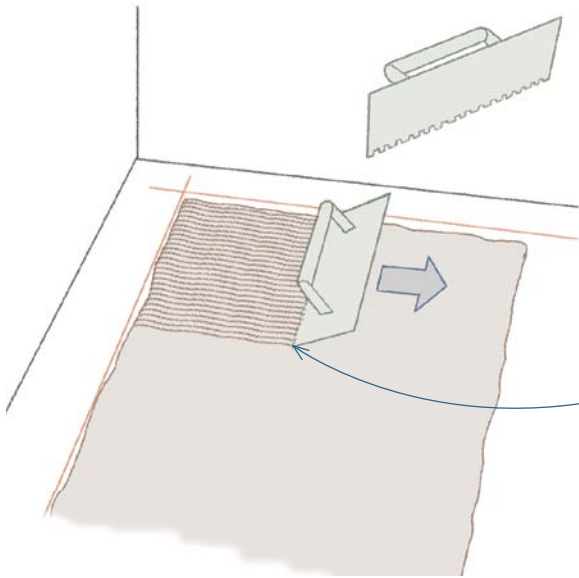

4 After spreading the mortar out, go over it with the notched edge of the trowel. Hold the trowel at about a 45° angle as you scrape it over the mortar, leaving ridges of mortar that are evenly spaced and of a consistent height.

5 Beginning along the baseline, set the tiles in the mortar.

6 When using large floor tiles, set one end down first, then lower the other end down into the mortar.

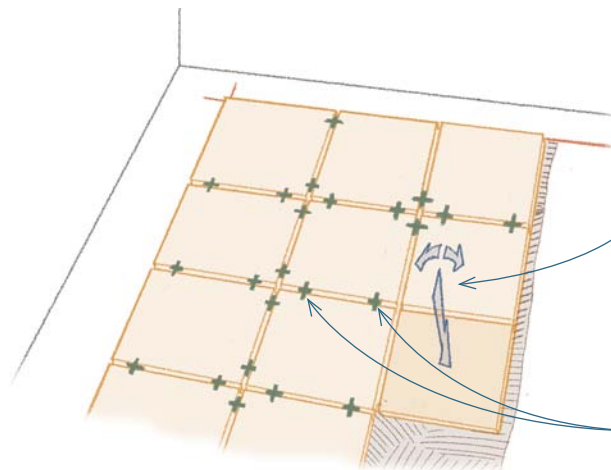
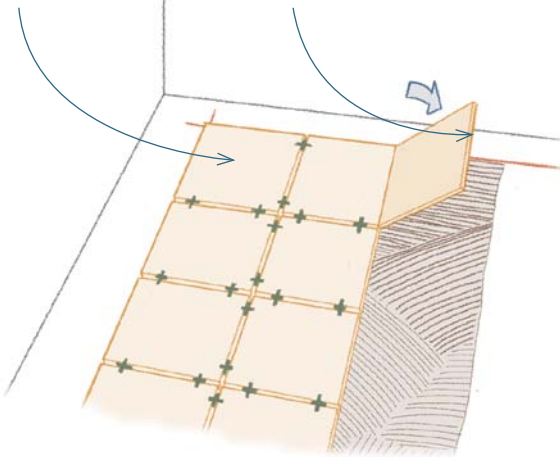

7 After setting the tile in the mortar, give it a slight twist as you press it down to help embed it in the mud.

8 Use spacers to keep the grout joints consistent.

Grouting and Cleaning

Grout fills the spaces between tiles. It comes in two forms. Sanded grout, which has sand as an aggregate, is used for joints that are larger than $\frac{1}{16}$ in. The sand helps grout shrink less as it dries. Plain grout has no sand and should be used for joints that are $\frac{1}{8}$ in. or less in width. Wait at least 48 hours before grouting the joints.

Mixing grout Mix the grout according to the instructions on the bag. In most cases, the manufacturer specifies that the grout should be slaked (left standing after mixing) for a given period of time, usually about 10 minutes. This reduces the amount that the grout will shrink and, thus, reduces the chance of hairline cracks forming in the joints. It's important not to skip this step.

After the slaking period, the grout may be a little stiff. Remix it vigorously, and it should loosen up sufficiently. If it's still too stiff to work with, it's OK to add water or a liquid latex additive, but do so sparingly. Add it gradually and use as little as possible.

TOP TIP

Use a Scrubby If the Grout Gets Ahead of You

.....
Keep a few green synthetic scouring pads handy (3M Scotch-Brite™) to help remove grout that has gotten too hard to remove with the sponge.

They cut more aggressively than the sponge, so keep them away from the grout joints.
.....

• APPLYING GROUT

1 Dump a load of the grout on the floor.

2 Push it over the tiles with a rubber grouting trowel.

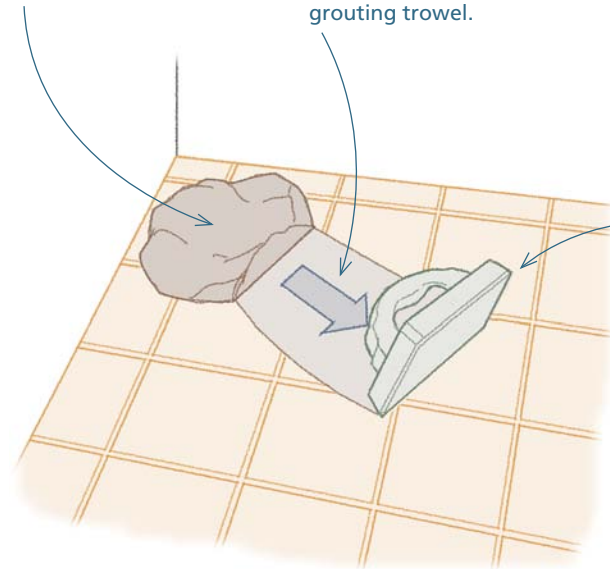

3 Hold the trowel at a steep angle as you spread the grout over a section of the floor. Then, with the trowel at a low angle, press the grout into the joints. After you've pressed the grout into the joints, hold the trowel at a steep angle and scrape it over the surface to remove the excess. Keep the edge of the trowel tight to the tile, and move the trowel at an angle to the joints. It's important to keep the edge of the trowel from aligning with the joints so it won't dig into the grout.

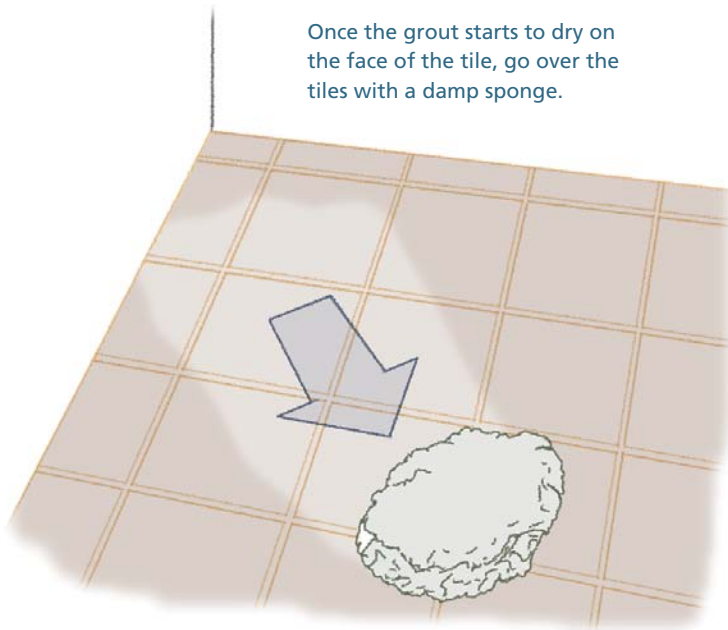

Cleaning the tile The biggest challenge of grouting begins now, after the bulk of the excess mortar has been removed by the grout trowel. The trick is to get the faces of the tiles clean without pulling the grout out of the joint. This requires patience, careful observation, and timing.

Wait until the grout starts to dry on the face of the tile, then go over the tiles with a damp sponge. Concentrate on the tile, and go very lightly over the joints. Rinse the sponge frequently, and wring it out thoroughly after each rinse.

Let any remaining grout on the face of the tile begin to harden again. When it begins to dry again, go over the tiles once more with a damp sponge. This time, put a little more pressure on the joints and try running the sponge along them. If the joints are ready, the sponge won't pull grout out. If they aren't ready and you notice too much grout being picked up by the sponge, lighten up on the sponge or wait a little longer.

Repeat the process one or two times. In the final pass, clean the sponge frequently and make long passes (the full reach of your arm). Wait until the grout dries, then polish the tiles with a clean terry-cloth rag.

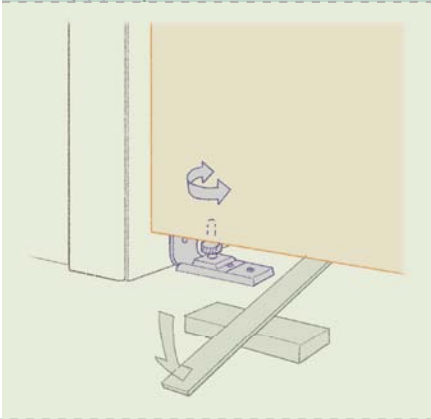
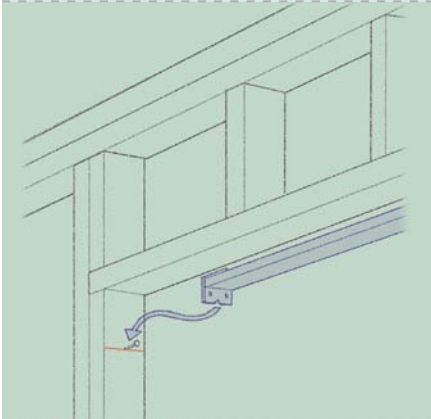
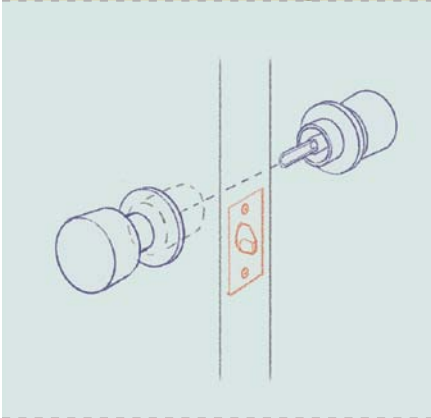
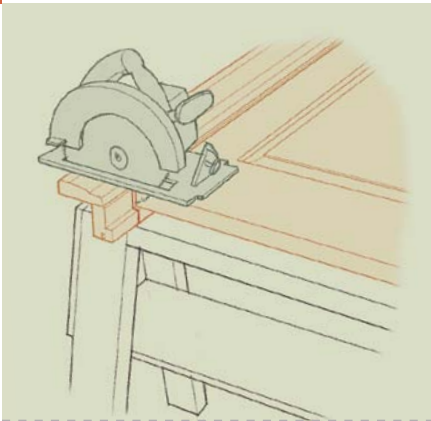

Hanging Doors

UNLIKE MOST OF THE THINGS carpenters build and install, doors move. They are mechanical devices that are used often and must operate smoothly. Getting a door to work properly, however, is only half the battle. Doors also must fit snugly in their openings. Most carpenters try to make the margin between a door and the jamb $\frac{1}{8}$ in. or less. This level of craftsmanship makes the door assembly look neat and professional and lends an air of quality to the house.

This chapter explains how to hang a variety of door assemblies in both new construction and remodeling. Much of the chapter is devoted to doors that swing on hinges. But many modern doors roll on wheels, which is covered at the end of the chapter.

Because different carpenters bring different combinations of tools to the job of hanging doors, this chapter will often offer more than one way of doing the same task. But however you approach it, the process will go smoothly only if the rough openings are reasonably square, plumb, and the right size.

On most jobs, the finish carpenters start by hanging and trimming out the doors. Several moldings and architectural elements, including base molding, chair rail molding, wainscoting, and, in many cases, cabinets and built-ins, must fit tightly against the outside edge of the door casing. This means that the doors have to be hung and cased out before carpenters can start on these other items.

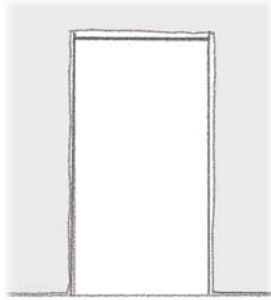

Rough opening,
square and plumb

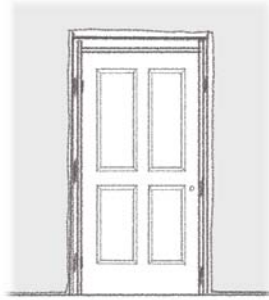

Prehung door
installed

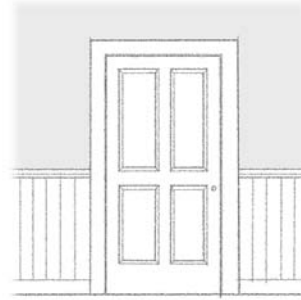

Door cased
and trimmed

Hanging Prehung Doors

Prehung doors come bored and mortised for the knobs and catches. They are hinged to preassembled jambs, which have the casing installed on at least one side. This factory fitting makes them easy to install with basic carpentry tools. Because they save time and money, they are used extensively in residential construction.

● TWO STYLES OF PREHUNG DOORS

One-jamb style

A one-jamb style includes the jamb with the casing on the side with the hinges, along with the door. Once this is installed, you install the casing on the opposite side of the jamb, just as you would for an exterior door or window.

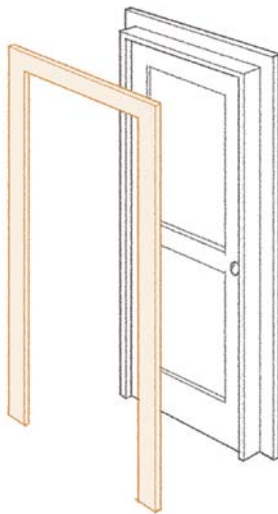

Split-jamb style

With a split-jamb style, the jamb comes with the casing mounted on both sides of the jamb. The jamb comes apart along a line that follows the doorstop. The part of the jamb without hinges fits, tongue and groove style, into the hinged side. The main advantage of using these units is that casings on the side without hinges are factory installed.

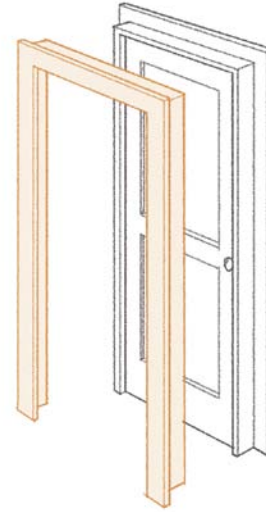

Because the split-jamb style is the most prevalent, that type will be used here to illustrate the procedure for hanging prehung doors.

STEP 1 Measure the rough opening

The unit needs to fit in the rough opening with a little extra space so you can make minor adjustments during the installation. The unit should fit with ½ in. to 1 in. of play around the perimeter. Measure the opening with a tape or carefully take off the non-hinge side of the split jamb, put it aside, and then simply pick up the other half of the unit (with the door attached) and see if it fits in the opening.

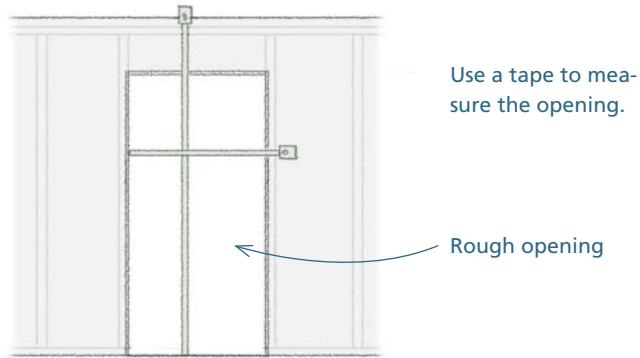

STEP 2 Trim the jamb to fit the rough opening

Sometimes, the unit will fit side-to-side but be a bit tall for the framed opening. This is usually because the preassembled jamb/casing is 1½ in. or so longer than the door, with the excess sticking out beyond the bottom of the door. Door manufacturers do this to allow plenty of room for the thickness of the floor covering (which is normally installed after the finish carpenters are done). If the unit is too tall to fit into the opening, cut enough off the bottoms of the jamb/casing assembly to allow the unit to fit, with a little to spare between the top of the unit and the header.



1 Set the assembly with the door in place across a pair of sawhorses.



2 Use a square and a pencil to mark the cuts on both the fronts of the casings and the insides of the jambs.

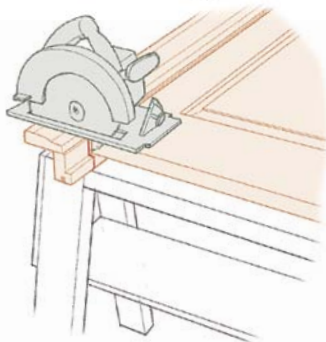

3 Use a circular saw to cut across the face of the casing and part of the jamb.

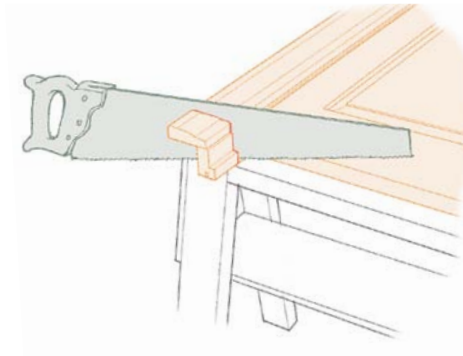

4 Then use a sharp hand-saw to cut the remainder of the jamb. (The other half of the split jamb can be cut at this time or wait until after the door is installed.)

Adjusting the Rough Opening

Once in a while, you'll need to make minor adjustments to the rough opening. Here are some common quick fixes:

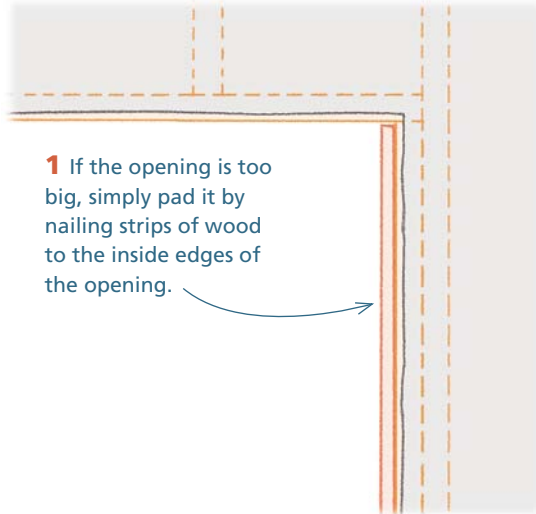

2 After you build in the opening, set the unit in place to make sure the casing extends over the drywall. If the casing ends up short of the drywall, you'll need to do some drywall repair before proceeding.

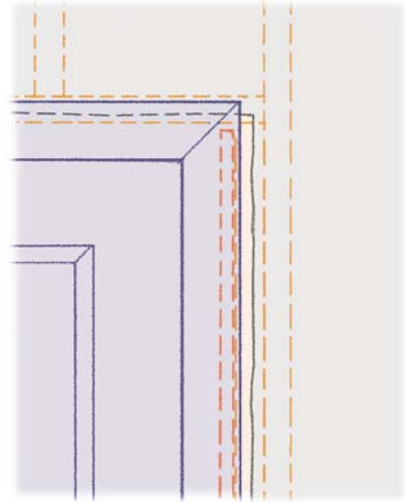

3 If the opening in a nonbearing wall is too narrow, carefully cut the drywall and remove the trimmer, then replace it with a 1x4. If need be, you can do this on both sides of the opening.

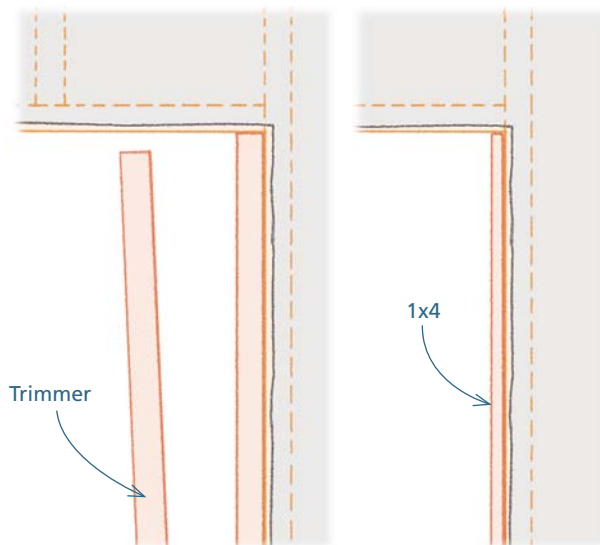

4 If the surface of the wall is out of plumb, kick the bottom plate over to bring the wall within an acceptable range. Place a block against the wall, and whack it with a sledgehammer until the wall is acceptably plumb.

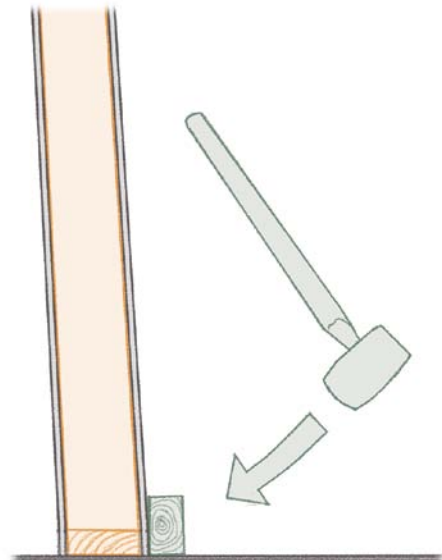

If you have to enlarge an opening in a bearing wall or if an opening is grossly out of square or out of plumb, you'll have to remove the drywall in that area and reframe the opening.

STEP 3 Check the rough opening for plumb

The problem of out-of-plumb wall surfaces is much aggravated if the top of the opening happens to be leaning in one direction on one side and in the other on the opposite side. This can cause the top or bottom of a door to hit the doorstop before the latch bolt catches on the strike, causing the ever-irritating door that won't stay closed. If the jambs are leaning in opposite directions, then you may want to make adjustments even if the out-of-plumb reading is less than $\frac{1}{4}$ in.

1 Place a 4-ft. or 6-ft. level against the inside edge of each side of the rough opening. If these are within $\frac{3}{8}$ in. or so of being plumb, the rough opening should be fine. If they're out of level by more than that, you may have to make adjustments to the opening (see "Adjusting the Rough Opening" on p. 357).

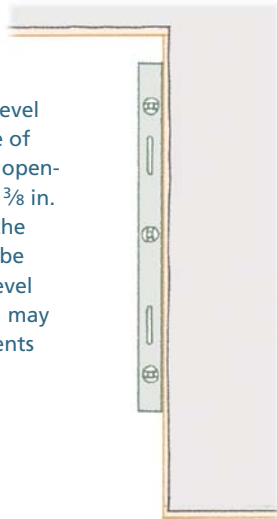

2 In addition to checking the inside edges of the opening for plumb, make sure the surfaces of the wall around the perimeter of the opening are plumb and in line with one another. Place the level vertically on the face of the wall just outside the opening. Do this on both sides of the opening. If the reading is the same on both sides of the opening and within $\frac{1}{4}$ in. of being plumb, the face of the wall is OK. If it's more than that, you may need to make adjustments.

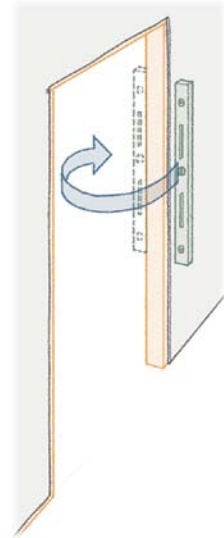

STEP 4 Check the floor of the opening for level

Place a 2-ft. level on the floor between the two sides of the opening, and slide it back and forth to determine if one side is higher than the other. If the floor is precisely level or the high side is the same as the side on which the hinges of the door will be, you're all set. If the high side is the latch side, you need to shim up the hinge side until it's slightly higher (about $\frac{1}{8}$ in.) than the latch side.

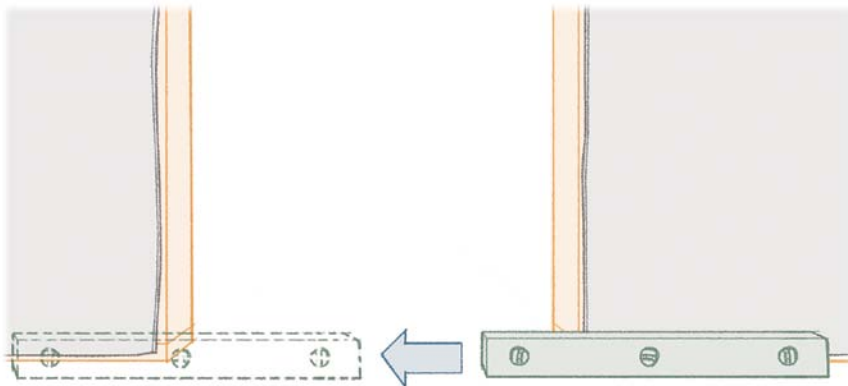

STEP 5 Shim the hinge side of the rough opening

1 Set the unit in the opening, and mark the location of the centers of the hinges on the wall. Make these marks on the wall just outside of the casing. Remove the unit and set it aside.

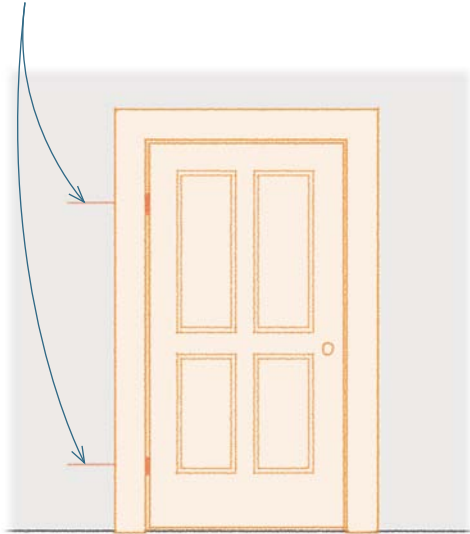

2 At the heights of these marks, install two or three pairs (depending on the number of hinges) of tapered shims on the inside edge of the rough opening. If this side of the opening is out of plumb, set the first pair of shims at the location that is leaning toward the inside of the opening. Adjust the overlap of the shims until they are about ¼ in. thick, and attach them with finishing nails.

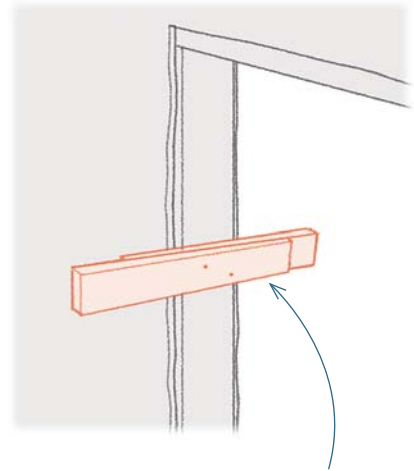

Once this pair of shims is attached, install the other pair of shims at the other hinge locations. Adjust the overlap of these until the faces are precisely plumb to the face of the first pair, either with a self-leveling laser or with a plumb bob.

Use a utility knife or saw to cut off the parts of the shims that extend past the face of the wall.

WAYS OF WORKING

Plumbing Door Shims

Laser level: To plumb pairs of door shims, set a self-leveling laser on the floor 2 in. from the inside edge of the rough opening. With the unit on, set a scrap of wood against the first pair of shims and mark where the laser beam strikes it. Adjust the second and third pairs of shims until the beam hits the same mark when you hold the scrap against it.

Plumb bob: Screw a small eyebolt into the underside of the header about 2 in. from the side of the rough opening. About 12 in. away from the eyebolt, drive in two nails that are angled away from each other to create a cleat. Thread the end of the plumb bob string through the eyebolt, pull the bob to the top, and bring it to a rest. Slowly lower the bob. When the tip is just above the floor, tie it off on the cleat. Use a scrap of wood in the same manner as just described, using the string as a reference.

Use a pencil to mark the floor just below the tip of the bob. This makes it easier to reset the bob if you happen to disturb it while nailing on the shims.

Laser-level method

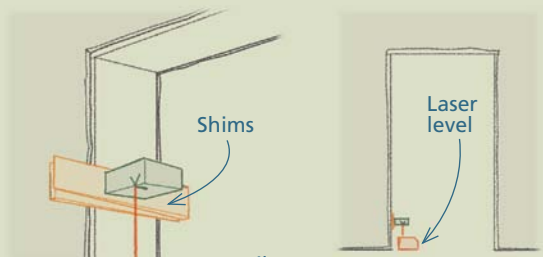

Plumb-bob method

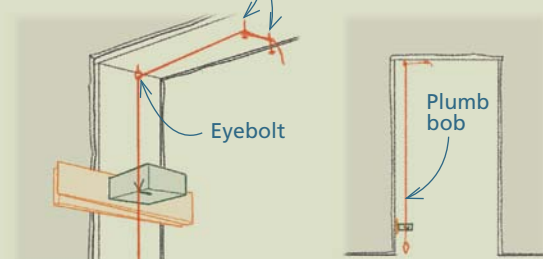

STEP 6 Hang the hinge side of the assembly

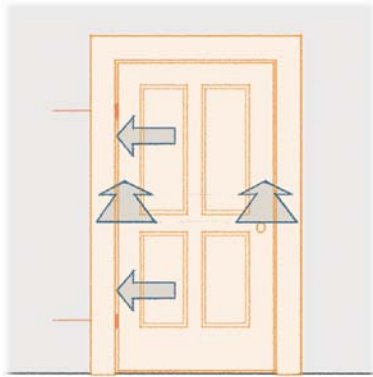

1 Set the assembly in the opening, pushing it tight against both the face of the wall and the shims you've just installed.

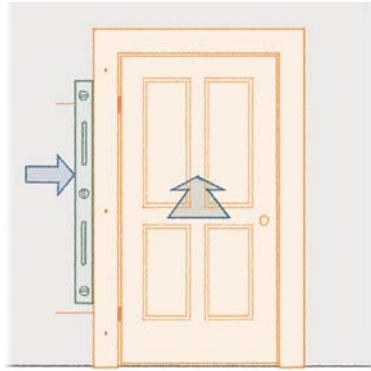

2 With a 4-ft. or 6-ft. level held along the outside edge of the casing on the hinge side, check for plumb. If the casing is plumb, drive two or three nails through it to attach the hinge side of the assembly to the wall.

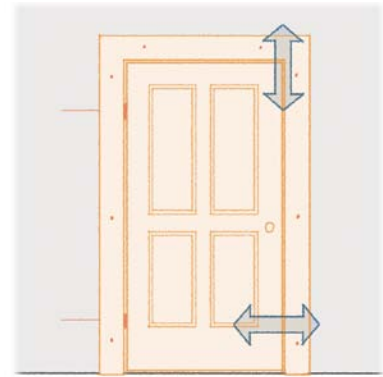

3 Adjust the other two pieces of the jamb/casing assembly by eye, using the clearance between the door and the jamb on the hinge side as a guide. Make the space, which is usually just under $\frac{1}{8}$ in., consistent all the way along the door and nail the other two pieces of casing to the wall.

STEP 7 Add shims and install the latch side of the split jamb

1 Open the door and step through the opening. Install shims on the latch side near the top and bottom and just behind the strike.

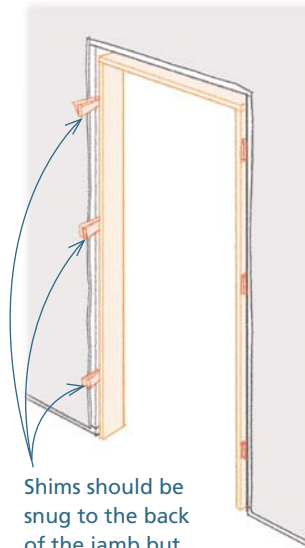

Shims should be snug to the back of the jamb but should not force the jamb to bow.

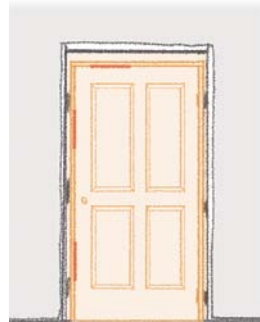

2 Check the fit as you go by closing the door and making sure the clearance between the door and the jamb stays consistent.

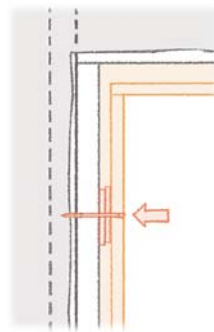

3 Remove one of the screws on the top hinge, and replace it with a screw that's long enough to penetrate through the shims to the jamb. Pre-drill to avoid splitting the shims.



4 Nail through the jamb at all the shim locations. Be sure not to nail through the groove that will receive the tongue of the other half of the jamb.



5 Insert the latch side of the split jamb, and attach it by nailing through the casing.

STEP 8 Install the closure hardware

Installing the hardware for prehung interior doors is simple because the door and jamb are already bored and mortised to accept the hardware.

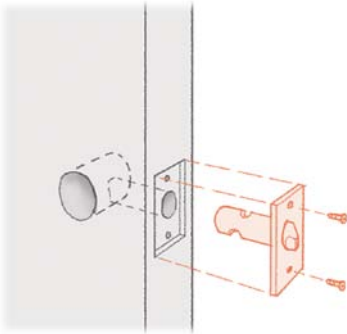

1 Screw in the latch bolt assembly, making sure that the bevel on the spring bolt is oriented correctly.

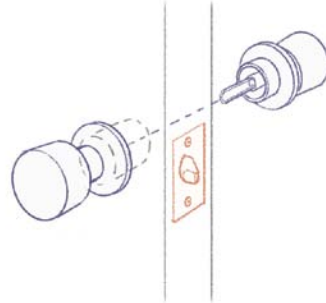

2 Insert the spindles of the door handles through the opening in the latch mechanism, and attach the handles with the long machine screws provided.

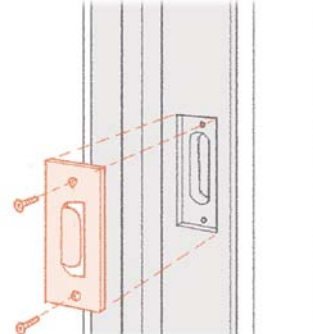

3 Screw in the strike plate to complete the closure hardware.

Fitting New Doors to Existing Openings

In residential remodeling projects, it's often necessary to fit new doors to existing openings. On these jobs, the carpenter has to start from scratch, boring and mortising a blank door to match hardware that's already in place. He also has to cut and plane the door to fit the size and shape of the existing door jamb. These jambs are seldom perfect. Many were built on site decades before carpenters had access to prehung units. If they were ever square and plumb, these jambs have almost always moved as the house has aged and settled. To do his job well, the carpenter must cut and shape the door so that it conforms to the quirks and eccentricities of the standing jamb.

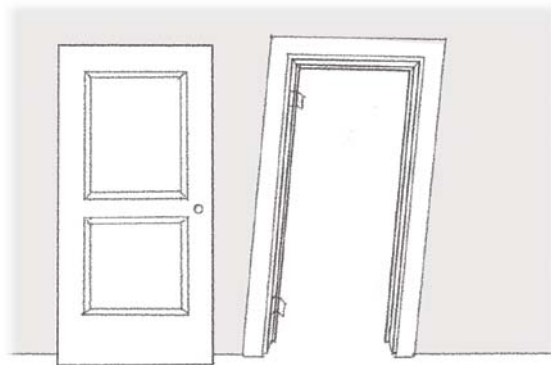

Jambs on existing openings in older homes are often out of square and out of plumb.

This section provides a step-by-step procedure for custom-tailoring a solid-wood door to an irregular opening. In the example shown here, the existing hinges and the strike are in place on the jamb and will be used with the new door.

• FITTING NEW DOORS TO EXISTING OPENINGS

STEP 1 Check the height and width of the opening

Check to make sure that the opening is no wider than the door plus $\frac{1}{4}$ in. As a rule, it's a lot easier to buy a door that's too big and cut it to fit than it is to enlarge a door.

Solid-panel doors usually have a very wide bottom rail, which can be cut down without making the door look out of balance.

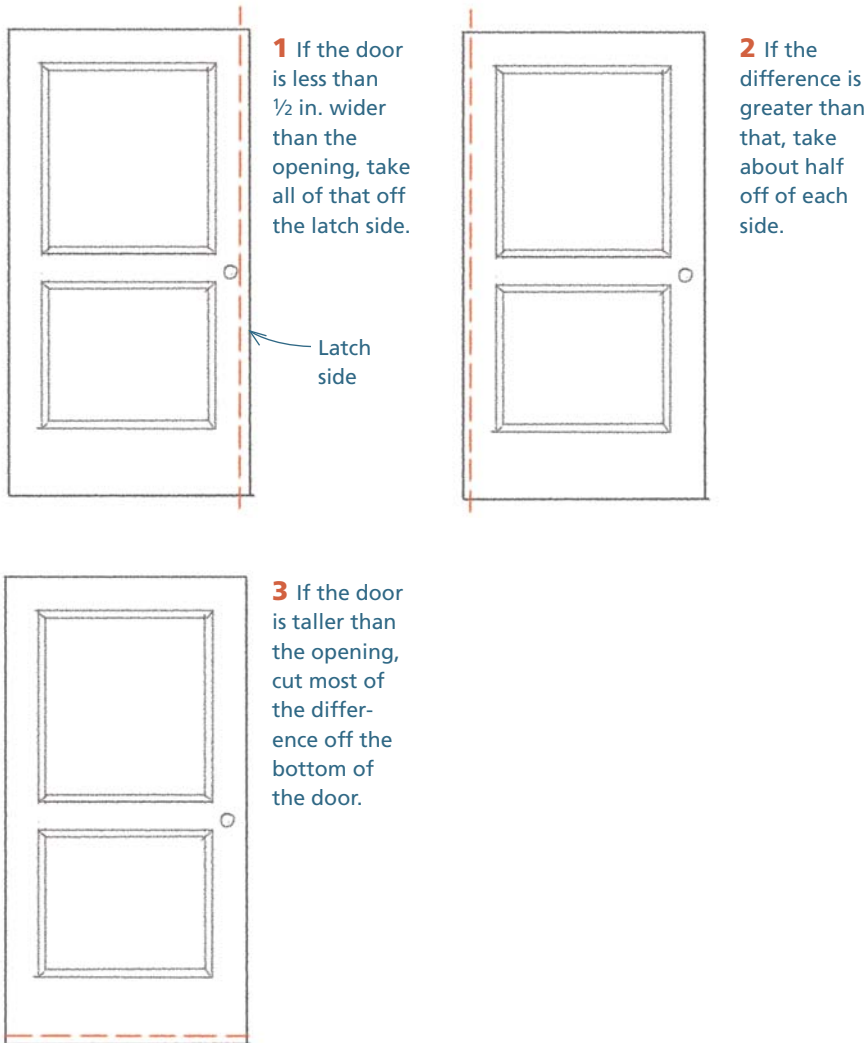

TOP TIP

Beware of Hollow-Core Doors

Hollow-core doors can be a bad choice for fitting to existing openings. They are hollow except for a thin strip of solid wood around the perimeter. These strips are often less than $\frac{3}{4}$ in. wide, which severely limits the amount of material that can be taken off the door to fit the opening. In older houses, which have widely varying door openings, it's a safer bet to use solid-wood doors for replacements.

STEP 2 Check the angle of the top of the opening to the hinge side

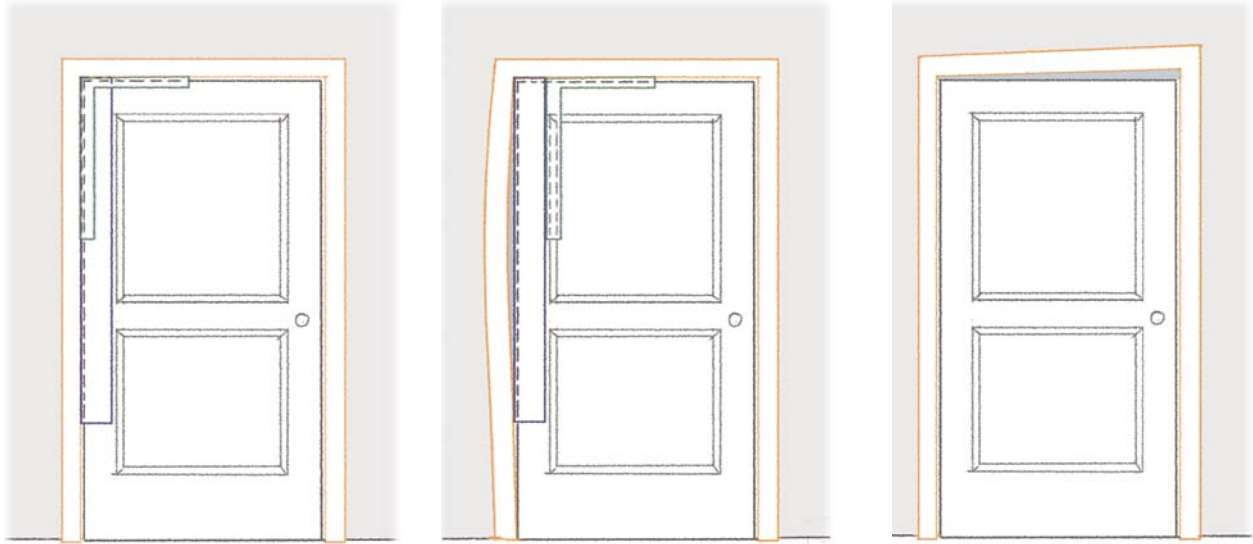

1 Use a straightedge to see if the hinge side of the opening is straight. If so, use a framing square to see if the header of the casing is square to the side. If the top is not square to the side, note which direction it deviates from a right angle and carefully measure the amount that it's out of square.

2 If the hinge side of the casing is not straight, hold the straightedge against the side of the casing, and then hold the square against the straightedge to check the angle of the header. The straightedge spans any dips in the casing and gives a more accurate measurement.

3 Checking the opening for square is important. If the top of the opening goes uphill as it moves away from the hinged side and you leave the door square, you'll end up with an unsightly wedged-shaped gap above the door.

STEP 3 Mark and cut the top of the door

If you've found that the top is not square to the side of the opening, cut the top of the door to conform to that angle before you lay out the hinge locations.

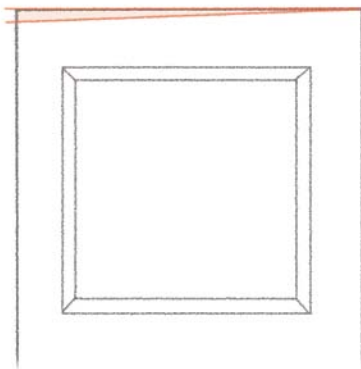

The locations of the hinge mortises cannot be marked before this cut because they must be measured from the top of the door after it has been fitted to the header.

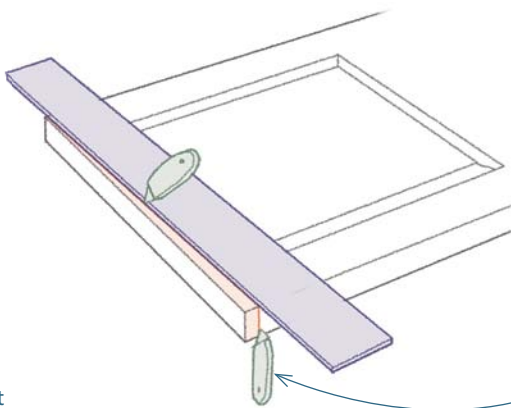

To make the cut, use a circular saw guided by a straightedge (see "Using a Saw or Router Guide" on p. 364). To minimize splintering, score the line with a sharp utility knife; be sure to carry this incision down the edge of the door where the saw will be exiting the cut.

Using a Saw or Router Guide

Using a guide is essential for cutting a crisp, straight line with a circular saw or plowing a straight groove with a router. There are several excellent factory-made guides available, but they are not essential. You also can achieve quality results using a square, a metal straightedge, or a straight piece of wood as a guide.

The best commercially available saw guides include the EZ Smart Guide and the Festool® Saw System, which can be set directly along the line you need to cut. These are excellent tools but they're expensive, and they require either matching saws (Festool) or saws equipped with special bases (EZ Smart). The EZ Smart Guide cannot be used with a router.

1 Clamp any board with a straight edge to your workbench or sawhorses. Clamp a large Speed Square on the board with the fence snug against the edge.

Less expensive saw guides and ones you might rig up on site are a little more difficult to use, but they are more versatile. These must be set up at an offset from the line you want to cut or rout. The size of the offset is equal to the distance from the edge of the sawblade or router bit to the edge of the base. To use these guides, hold the base of the saw or the router against the guide as you push the tool through the workpiece.

Fabricating a site-built gauge

The most difficult part of using one of these site-rigged or less expensive guides is getting the straightedge precisely offset from the cut. The easiest way to find this distance is to fabricate a site-built gauge. Here's a simple procedure for making this gauge:

2 Use a pencil to mark the board along the edge of the square that runs perpendicular to the edge of the board.

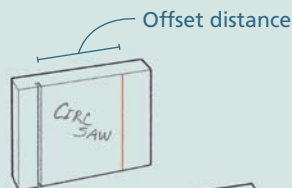
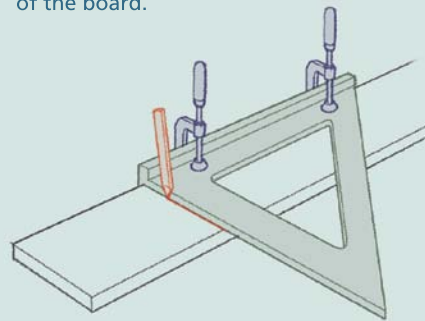
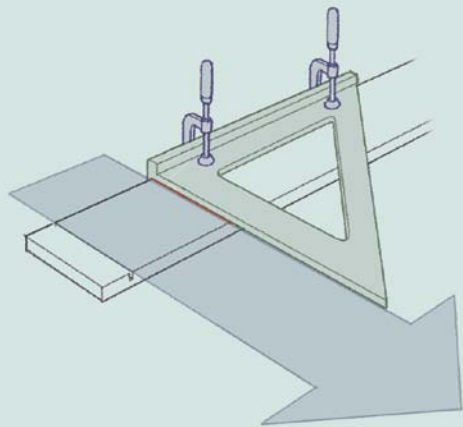

3 Set the tool you're going to use (your saw or router) to make a shallow cut (1/8 in. to 1/4 in.) in the board. After removing the square, the distance between the line and the edge of the cut is the precise offset distance needed.

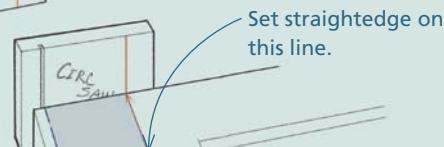

Desired cut line

You can now cut this section off the board and use it as a gauge for laying out the precise location of your straightedge.

STEP 4 Bevel the edge of the hinge side

After you've trimmed the top, the door is locked into an orientation; there is a hinge side edge, a latch side edge, an outside face (the side with the hinge pins), and an inside face (the side that closes against the doorstop). Label these in pencil to avoid mental lapses as you work.

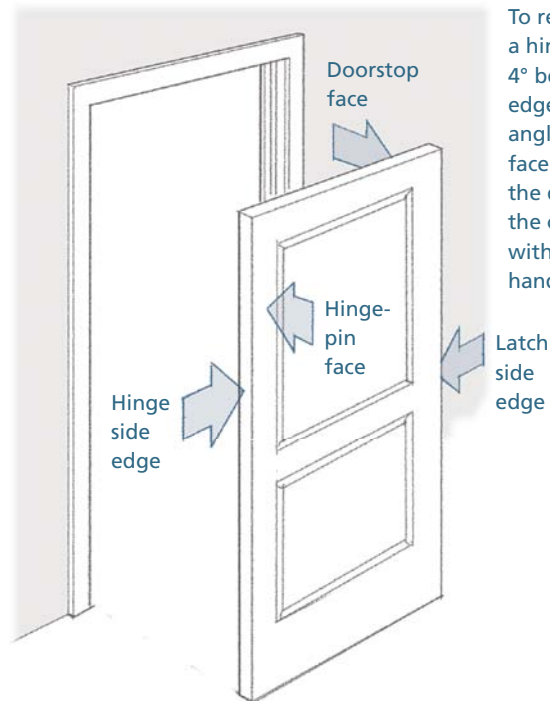

To reduce the possibility of a hinge-bound door, put a 4° bevel on the hinge side edge. The bevel should angle in from the outside face toward the center of the door. After you've made the cut, you can smooth it with a few passes of a sharp handplane.

STEP 5 Cut the bottom of the door, if necessary

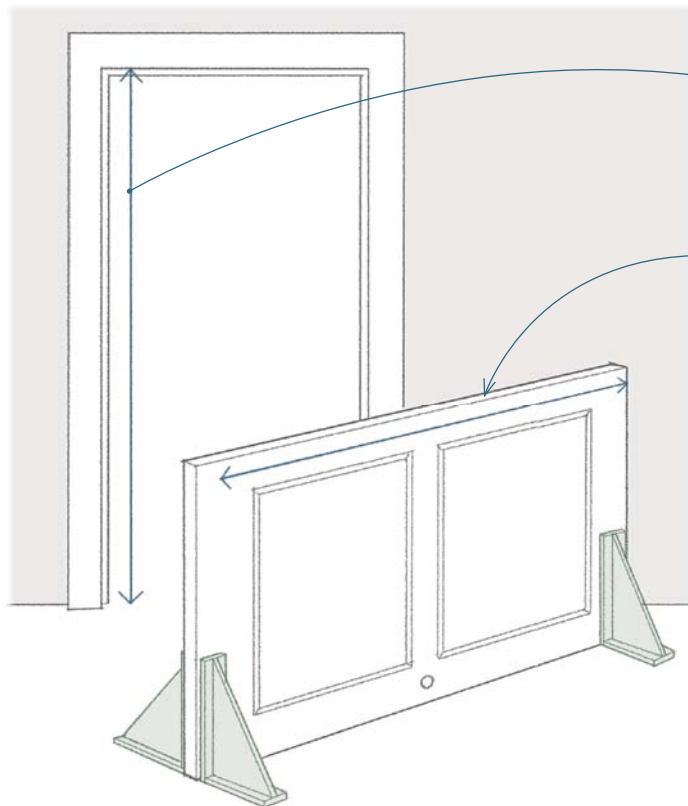

1 Measure the distance from the floor to the top of the opening along the hinge side jamb.

2 If this distance is less than the hinge side edge of the door, cut the bottom of the door.

STEP 5 Cut the bottom of the door, if necessary (continued)

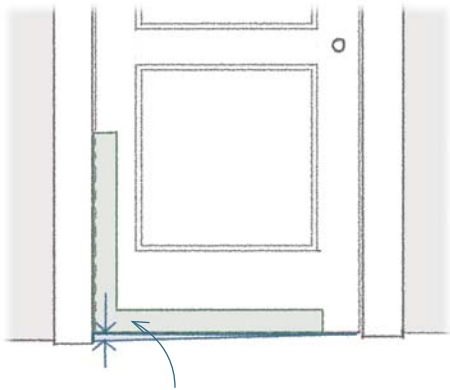

3 Before you mark the door, use a framing square and a straightedge to see if the floor is square to the hinge side jamb. Note the direction and amount that it deviates from square.

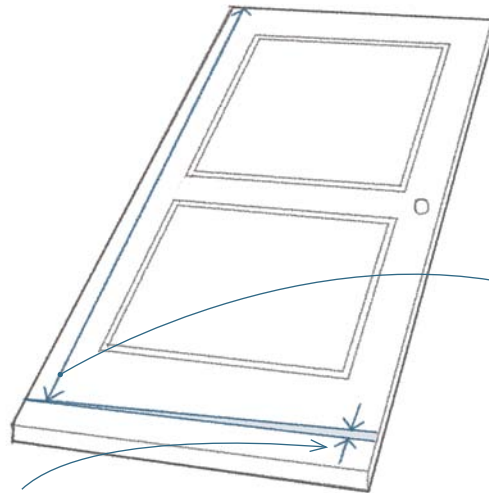

5 Extend a line over from this mark that reflects any deviation from square that you detected.

4 After you've checked for square, measure down from the top of the hinge edge of the door, and mark a distance that is $\frac{1}{2}$ in. less than the distance you found when measuring the jamb.

TOOLS & TECHNIQUES

Securing a Door on Edge

It's often necessary to hold a door securely on edge as you work on it. There are factory-built brackets that do this, but most carpenters simply fabricate door-holding brackets out of scrap. One design is the pair of L-shaped brackets shown here.

To use, place the brackets back-to-back with the door sandwiched between them, and then clamp the whole works together with a C-clamp or a small bar clamp.

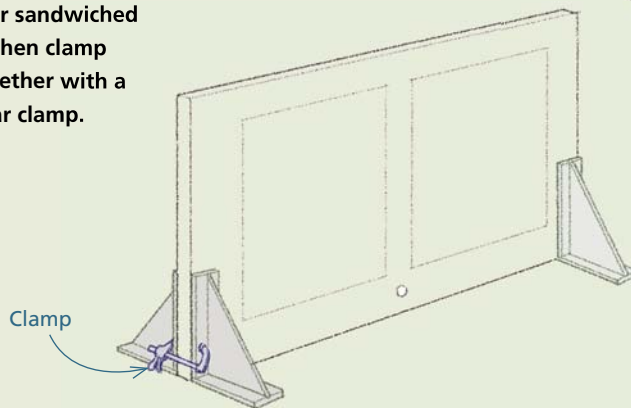
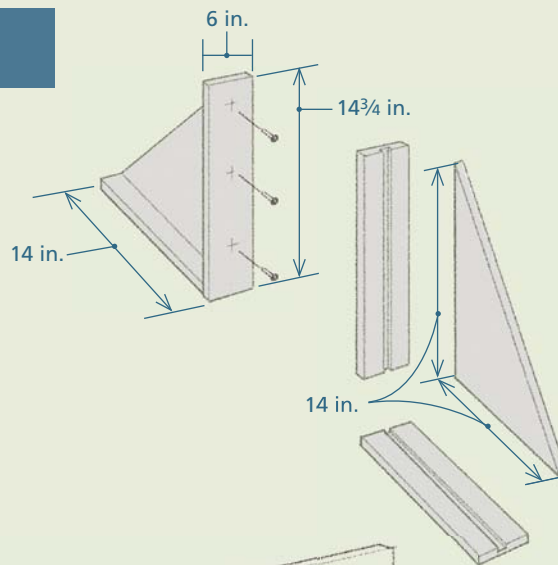

STEP 6 Install the top hinge on the door

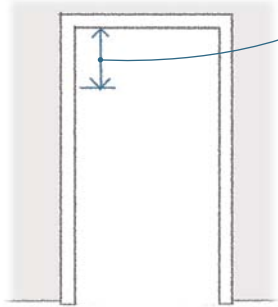

1 Measure the distance from the underside of the header casing to the top of the first hinge.

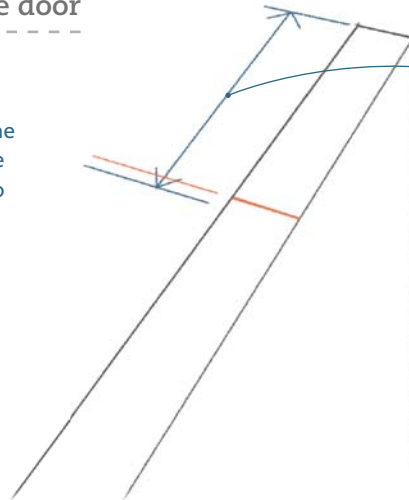

2 Measure the same distance down, minus $\frac{1}{8}$ in., and mark that amount on the hinge edge of the door.

Secure the door on edge with the hinge side up (see “Securing a Door on Edge” on the facing page).

3 Remove the pin from the hinge, and use the leaf to mark the bottom of the top hinge on the door.

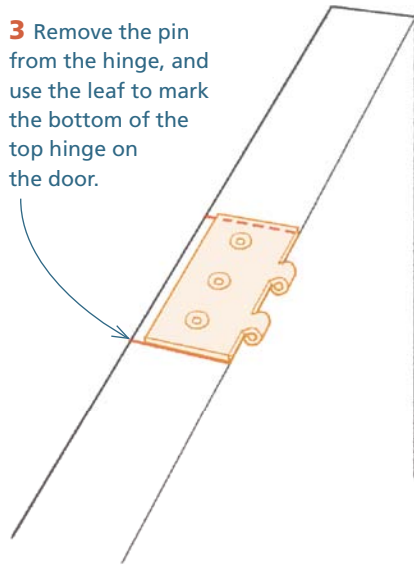

4 Once the bottom is marked, go back to the jamb and measure the distance from the front edge of the jamb to the back of the hinge.

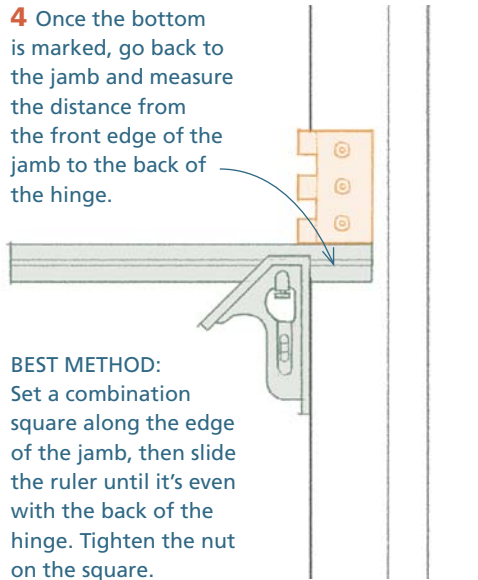

BEST METHOD: Set a combination square along the edge of the jamb, then slide the ruler until it's even with the back of the hinge. Tighten the nut on the square.

TOP TIP

A Forgotten but Still Useful Tool

If you have a butt-marking gauge that's the same size as the hinge that you're installing, it may work for marking the hinge mortises on the new door. Carpenters have been using these gauges for generations, and there's a fair chance that it will match the height and width of the mortises on the jamb. To use

the butt marker, slide it on the edge of the door until the stops come in contact with the corner. Smack it with a hammer to mark the sides and back of the mortise. Before you use it on the door, give it a test run on a scrap of wood to see if it matches the mortises on the jamb.

STEP 6 Install the top hinge on the door (continued)

5 Use the combination square to mark the back of the hinge mortise.

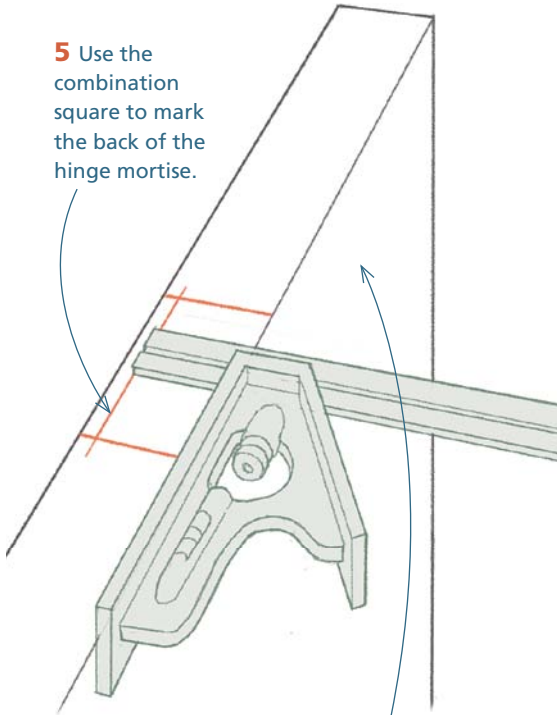

Make sure to place the fence of the square on the outside face of the door (the side that will have the hinge pins) as you mark the back of the mortise.

6 Cut the outside of the mortise with a utility knife fitted with a new blade.

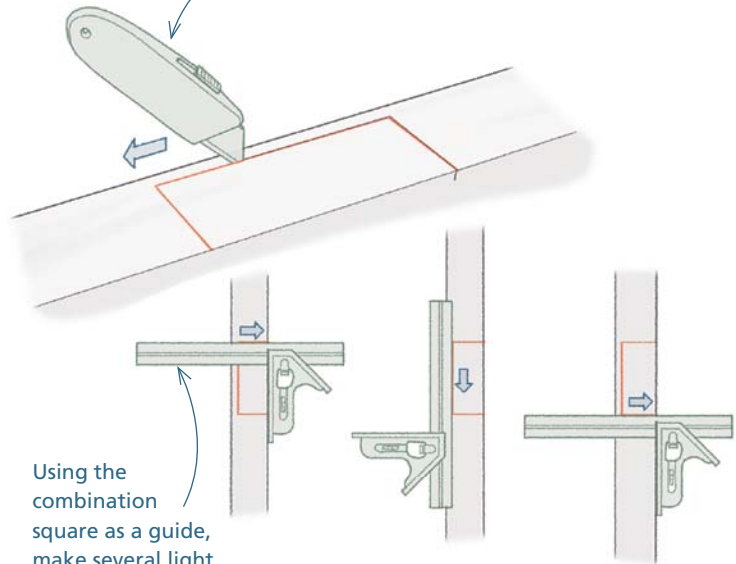

Using the combination square as a guide, make several light, controlled cuts.

7 Install a straight mortising bit in your router, and use a trial-and-error process with scrap to set it to the correct depth (the thickness of the hinge).

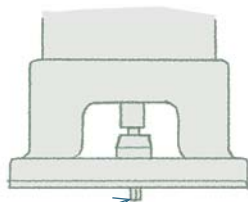

Set the bit as close as possible by eye.

Clamp a scrap of wood to the worktable.

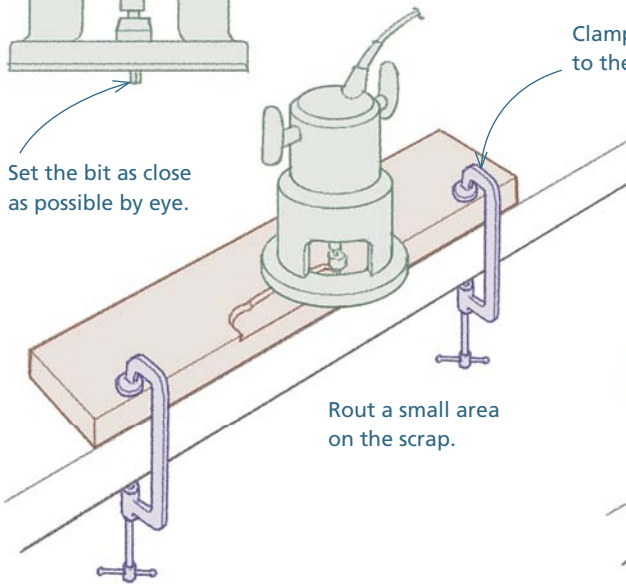

Rout a small area on the scrap.

Place the hinge leaf in the recessed area to check the depth.

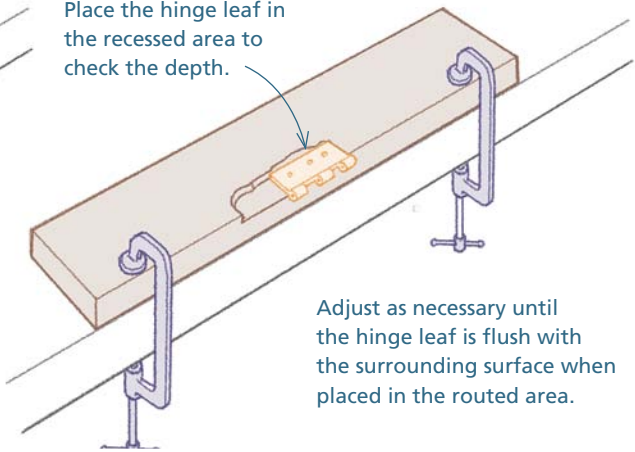

Adjust as necessary until the hinge leaf is flush with the surrounding surface when placed in the routed area.

(continued on p. 370)

WAYS OF WORKING

Options for Mortising Hinges, Latch Plates, and Strikes

There are two basic ways to cut mortises: with a chisel and hammer, or with a router fitted with a straight, bottom-cutting bit.

Using a chisel and hammer

Although they don't cut as fast as a router, chisels require no setup time and they can be used in places that are not accessible to power tools. For a single mortise, it's often faster to use a chisel and a hammer than it is to set up a router and a template. The key to using chisels effectively is to have a sharp edge. (Note: If you happen to have nice, wood-handled chisels, you may prefer to use a mallet instead of a hammer.)

Using a router

Aside from the speed at which it cuts, one of the biggest advantages to using a router to cut mortises is that you can set the depth of the cut with great precision. On the down side, it's hard to see the cutter because the base is in the way. It's also hard to control the side-to-side movement of the router with the bit spinning at 10,000 to 30,000 revolutions per minute.

Because the lateral movement is difficult to control, it is often best to use templates. Templates constrain the movement of the router. There are two basic ways these templates work. In one, a bearing that's slightly wider than the cutter is mounted on the shank of the router bit just above the cutter. As the bearing rides along the inside edge of the template, the bit of the router cuts the mortise below.

Templates also work with guide collars attached to the base of the router. The router bit fits inside the collar. As the collar rides along the inside edge of the template, the bit cuts the mortise below.

Tool manufacturers offer many kinds of router templates. One of these, Templaco Tools (www.templaco.com), specializes in templates for mortising

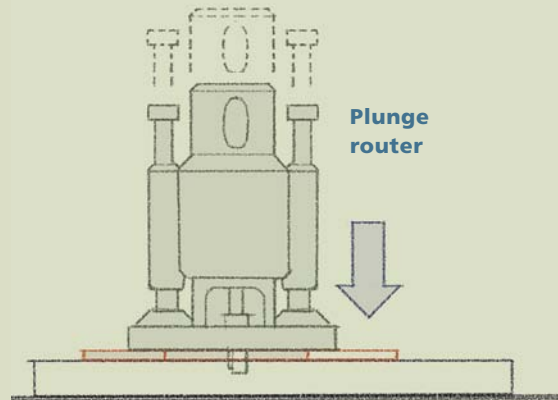
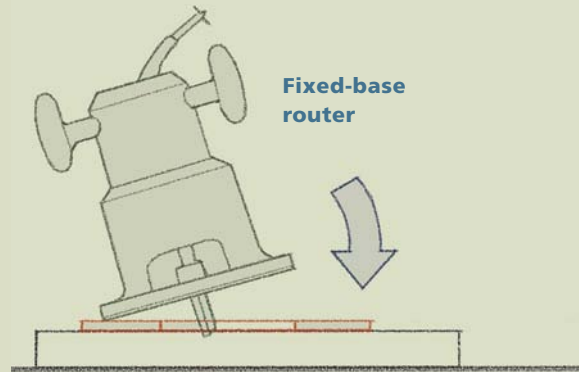

doors. Templates are simple brackets, however, and many carpenters simply make their own on site.

One type of mortise that's conducive to freehand routing is the mortise for a hinge. Because you need to cut one side all the way to the edge of the door, it's easy to enter the cut from that open side. Once the router bit is cutting inside the marked mortise, make sure you stay $\frac{1}{8}$ in. or so away from the perimeter. You can clean up the final $\frac{1}{8}$ in. quickly with a sharp chisel.

Routing inside a template

Because templates for hinges, strikes, and latch plates are usually enclosed on all four sides, you have to lower a spinning router bit into the workpiece. Carpenters often do this by tilting a fixed-base router into the area enclosed by the template. This can be hazardous because the bit can catch and jerk the router. It's a lot safer to use a plunge router, which enters the cut with the entire base firmly planted on top of the template. No matter which router you use, always secure the template to the work and hold the router firmly with two hands.

STEP 6 Install the top hinge on the door (continued)

8 Take the router over to the door, and rout most of the mortise freehand. Stay about $\frac{1}{8}$ in. away from the incised perimeter.

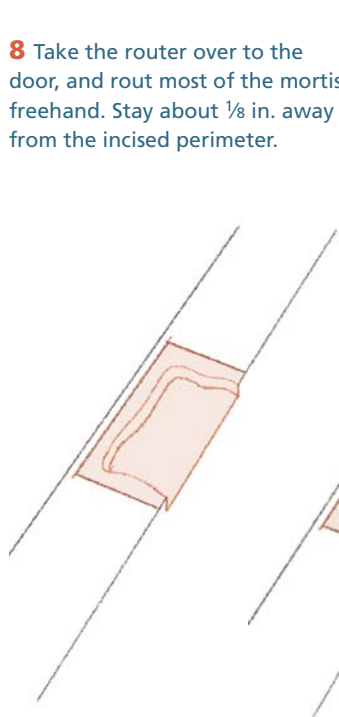

9 Use a sharp chisel to remove the area around the perimeter.

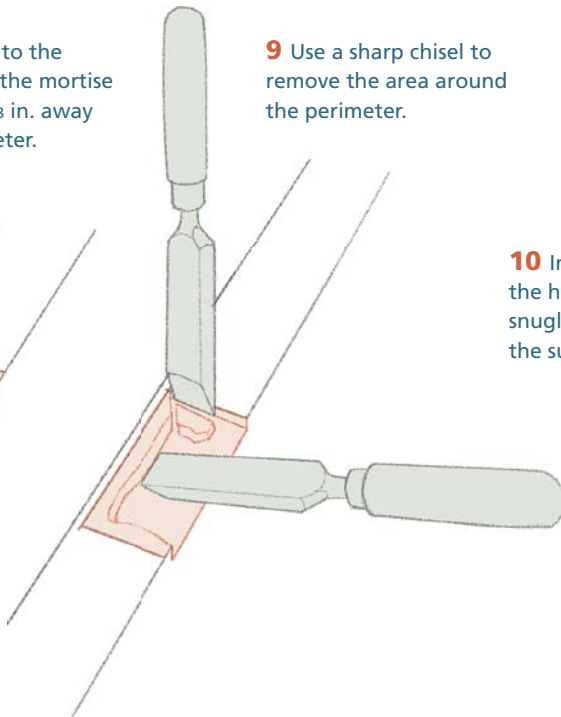

10 Install the leaf of the hinge. It should fit snugly and be flush with the surface around it.

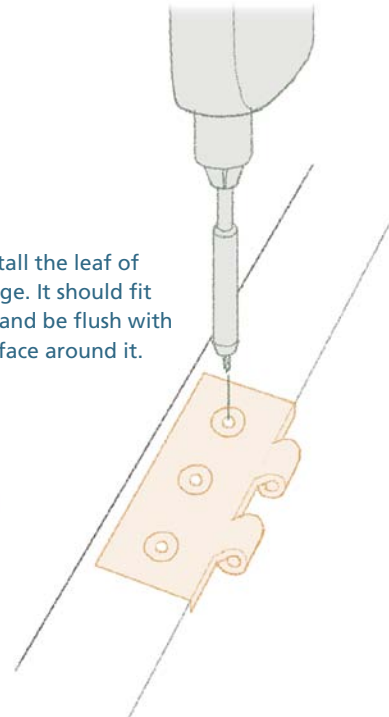

STEP 7 Mark and install the other hinges

1 Close the two lower hinges on the jamb. With the leaf of the top hinge on the door, bring the door over to the opening and drop in the hinge pin.

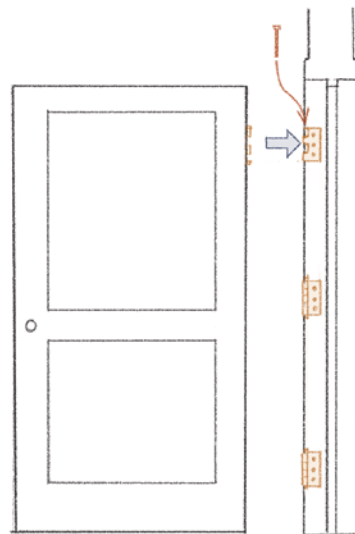

2 Open the lower hinges, and mark the edge of the door along their top and bottom edges.

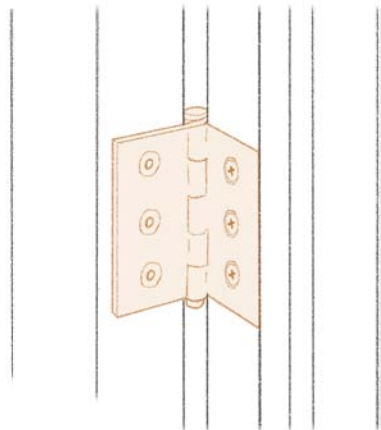

TOP TIP

Use Vix Bits for Hinge Screws

Use Vix bits to predrill for the screws. These spring-loaded bits are sheathed in cylindrical guides that keep them centered in the screw holes of the hinge. Standard drill bits can wander.

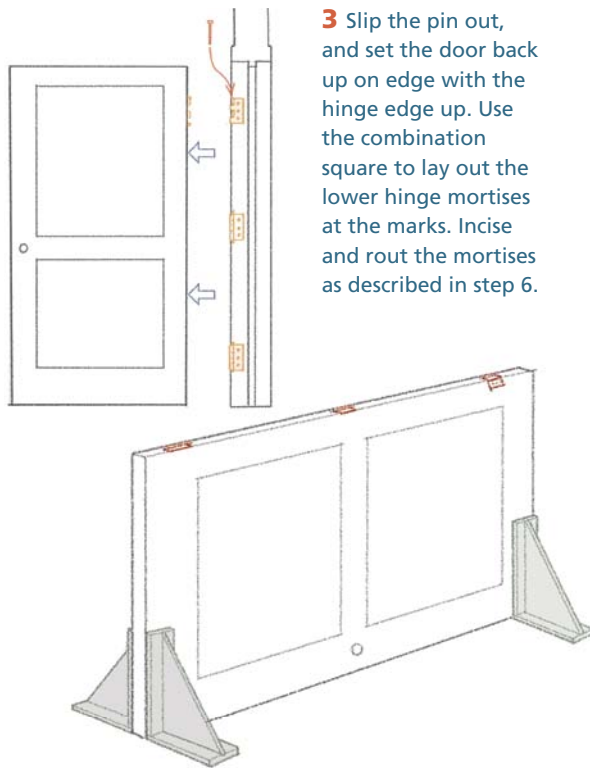

3 Slip the pin out, and set the door back up on edge with the hinge edge up. Use the combination square to lay out the lower hinge mortises at the marks. Incise and rout the mortises as described in step 6.

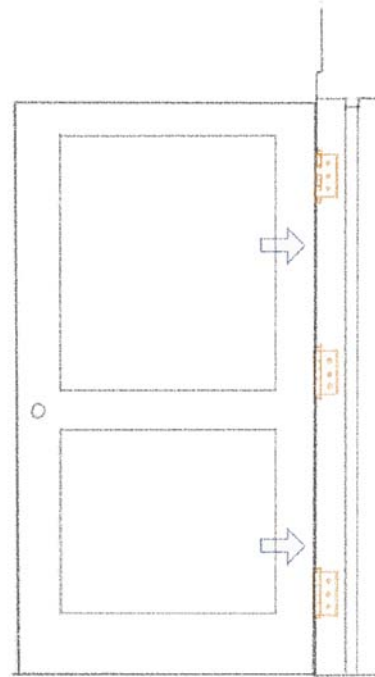

4 Bring the door back over to the opening, and drop the pin in once again. Check to see if the two lower hinges fit properly in the mortises. If not, mark where they need to be trimmed, remove the pin, and make the modifications. When the hinges on the jamb fold back into the mortises, drill and screw them into the door.

STEP 8 Cut and fit the latch side of the door

In addition to fitting the door to the opening, the latch side of the door should be beveled 3° to allow the leading edge of the door to clear the jamb as it's closed.

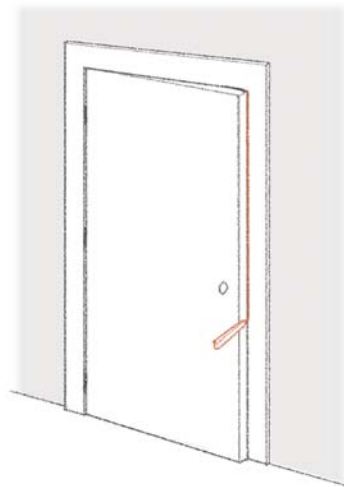

1 Swing the door to the closed position, and mark the casing on the latch side where the door meets it.

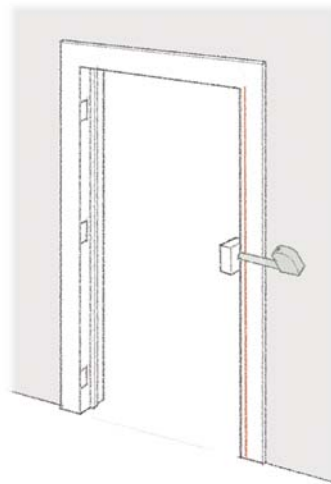

2 Take out the hinge pins and remove the door. Hold a block of wood against the face of the jamb with an inch or so projecting past the edge. Measure over from the side of the block to the line you've just made on the casing. Make these measurements in three or four places over the length of the casing.

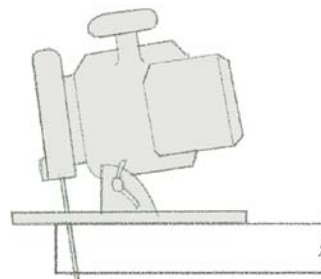

3 Transfer these measurements to the face of the door, and set up a saw guide with the proper offset from the marks. Set a circular saw to 3° and cut the door. Make sure the bevel tilts toward the center of the door from the hinge pin face.

Options for Boring Doors and Strikes

Boring locksets

There are two basic ways to bore doors for locksets: using common carpentry tools, or using a door-boring jig.

• COMMON CARPENTRY TOOLS

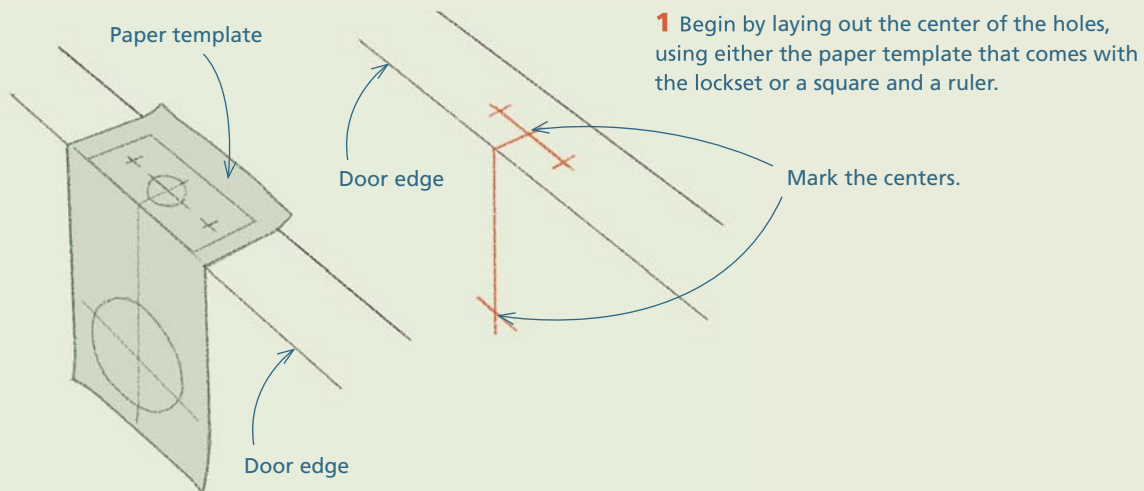

1 Begin by laying out the center of the holes, using either the paper template that comes with the lockset or a square and a ruler.

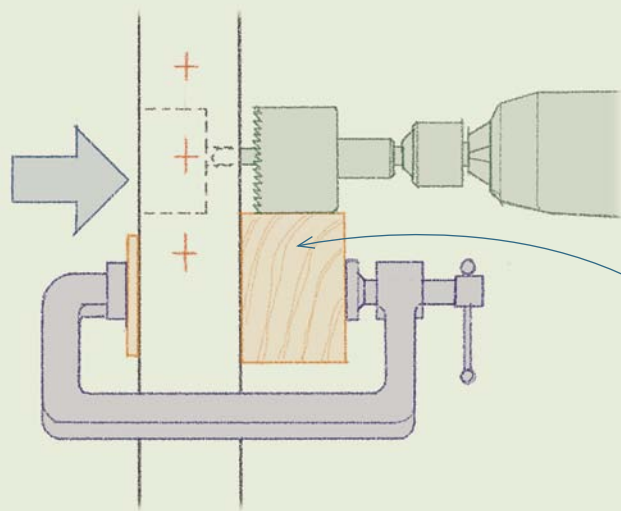

2 Carefully bore the holes with a portable drill. To help keep the doorknob hole from drifting off the layout and to prevent the bit from splintering the face of the door, lay out both sides of the door and drill about halfway through from each side.

To help keep the latch hole centered, you can clamp a piece of wood to the door and use it as a guide as you drill.

• DOOR-BORING JIG

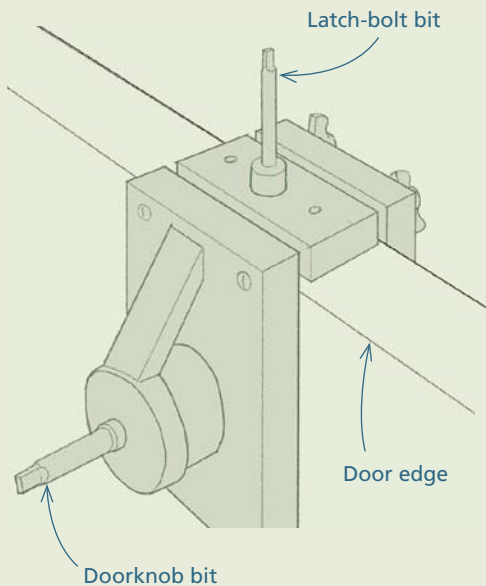

1 The jig speeds up the job and ensures accurate results. There's no need to lay out the centers of the bores. For the doorknob bore, the jig is set to drill a standard $2\frac{1}{8}$ -in. hole that's precisely centered at the backset, $2\frac{3}{8}$ in. from the edge of the door.

2 For the latch bolt, the bore jig centers the hole in the edge of the door and aligns it with the doorknob bore. The jig holds the bits square to the door and prevents them from wandering out of alignment. Simply clamp the jig on the door at the correct height and drill the holes with the bits provided.

Always drill the doorknob holes before the latch-bolt holes. With a door-boring jig, there's no need to drill the doorknob holes from both sides of the door. The surface of the jig applies pressure against the opposite side of the door, which keeps the surface from splintering when the bit exits the hole.

Boring deep mortises

• COMMON CARPENTRY TOOLS

One way to cut the deep mortises required for mortise locksets is to drill a series of overlapping holes in the edge of the door. To get the holes the right depth, mark the drill bit with tape or a felt-tipped pen. After you finish drilling the holes, clean up the sides of the mortise with a sharp chisel.

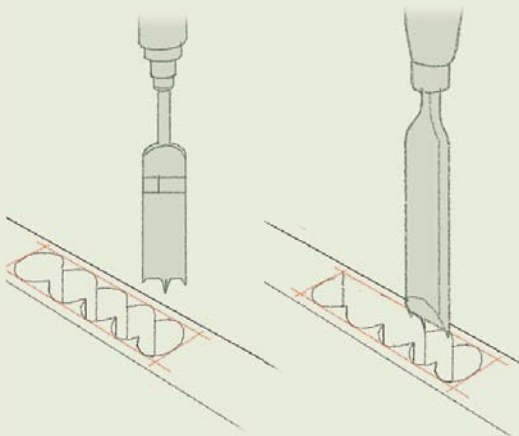

• LOCK MORTISER

The second way to cut the mortises is to use a special-purpose tool called a lock mortiser, which consists of a powerful router mounted on a jig that clamps to the door. Porter-Cable® and Bosch offer slightly different versions.

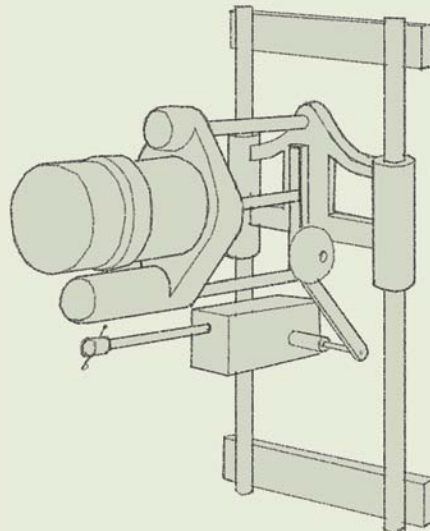

STEP 9 Install the closure hardware

This section describes the layout for installing a standard doorknob with a 2³/₈-in. backset.

1 Open the door and mark the location of the center of the latch hole on the outside edge of the strike.

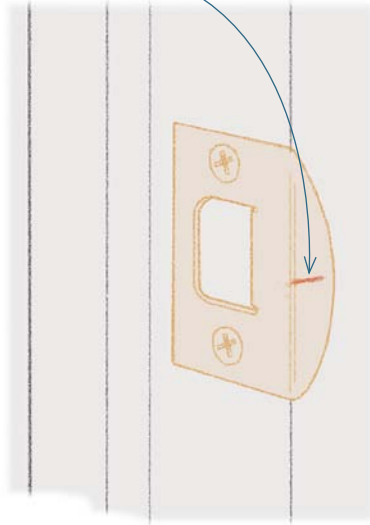

2 Close the door and transfer the mark to the door.

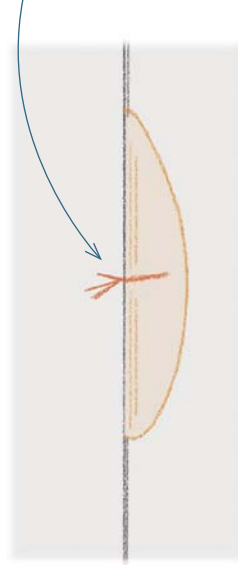

3 Open the door again and use a square to draw a line perpendicular to the edge of the door at the mark.

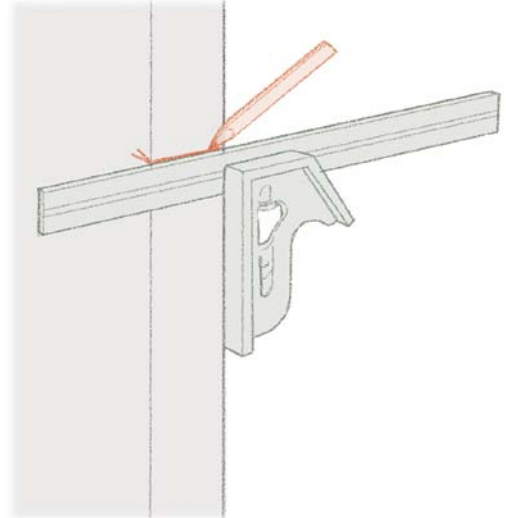

5 Set the combination square to 2³/₈ in. and mark the backset.

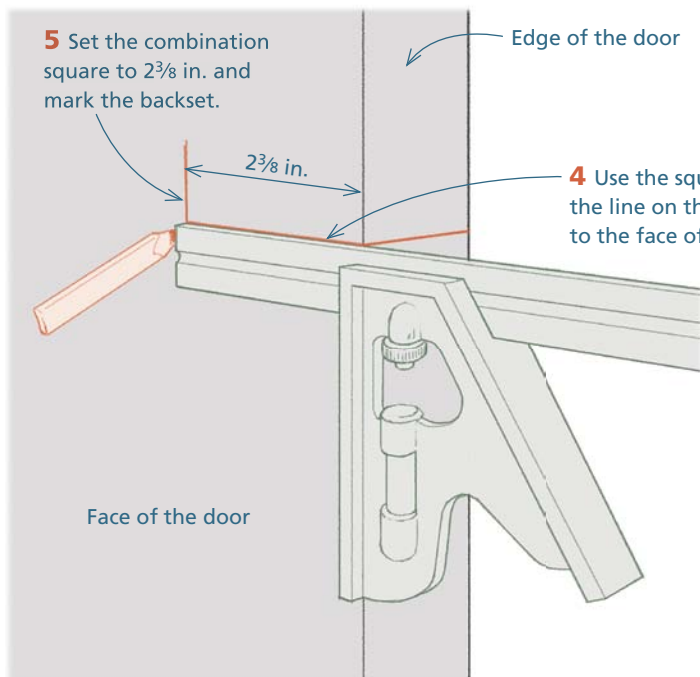

4 Use the square to bring the line on the edge out to the face of the door.

After laying out the location of the latch and backset, bore the holes using one of the methods discussed on pp. 372-373. Mortise the latch and strike plates with a sharp chisel or a router as described on pp. 368-370. Install the closure hardware to complete the job (this task is described on p. 361).

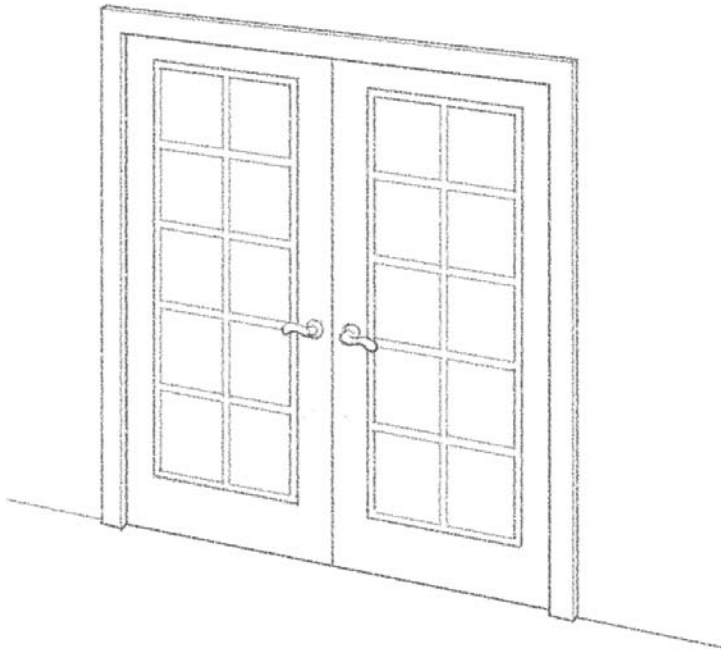

Hanging French Double Doors

Strictly speaking, any door that has glass along its full length is a French door. French double doors, however, are the most popular style. These doors swing on hinges mounted on the opposite sides of an opening and meet in the middle. One door is fixed in place by sliding bolts, while the second swings freely and latches to the fixed door. By retracting the slide bolts, the fixed door can also swing freely, thus creating an opening the size of two doors.

Prehung French double-door assemblies are available for both interior and exterior applications. They are fairly easy to install and are the first choice of most builders for new construction and additions. In some older houses, however, prehung French double-door assemblies are not the best choice. Where there is already a large cased opening, it often makes sense to preserve the existing opening. This ensures that you won't damage plaster or destroy old, hard-to-find molding. In these cases, it's easier and less expensive to carefully fit a new pair of doors to the existing opening.

This section provides a step-by-step procedure for fitting double doors to an existing opening such as you might find between the dining room and the hall in an older home.

● HANGING FRENCH DOORS

STEP 1 Check the opening

Check the height and width of the opening before you buy the doors. The combined width of the new doors needs to be as wide, or wider, than the width of the opening. The standard height of doors has been 6 ft. 8 in. (80 in.) for a long time. However, because the cased opening might not have been built for a door, it's important to make sure the height is within an acceptable range for the doors. If it's outside that range, you'll need to buy shorter or taller doors or have them custom built.

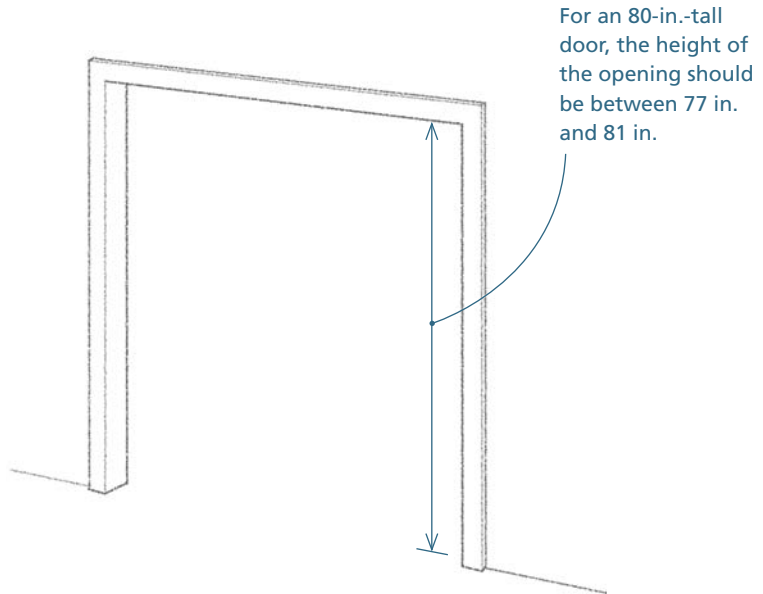

STEP 2 Cut and fit the doors roughly to the opening

Take an equal amount off all four sides to roughly fit the two doors to the width of the opening. Leave the total width of the two doors about $\frac{1}{4}$ in. wider than the opening. If the top of the opening is not square to the sides, cut the tops of the doors to conform to that deviation from square. Cut the bottoms, if necessary.

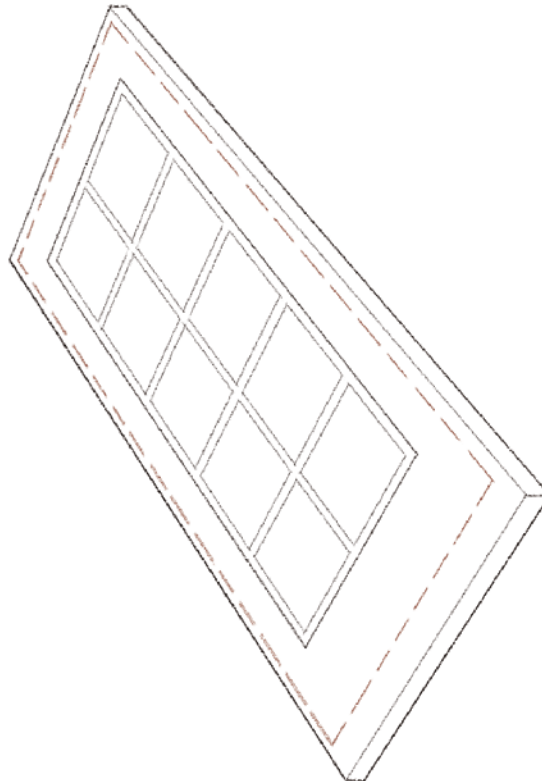

STEP 3 Hang the fixed door

With two minor differences, you can use the same basic approach as the one described on p. 370 to hang the door. The first difference is that you have to lay out the hinge locations from scratch in this situation. The second is that you have to transfer the hinge locations from the door to the jamb. In the previous example, the hinge locations were transferred from the jamb to the door.

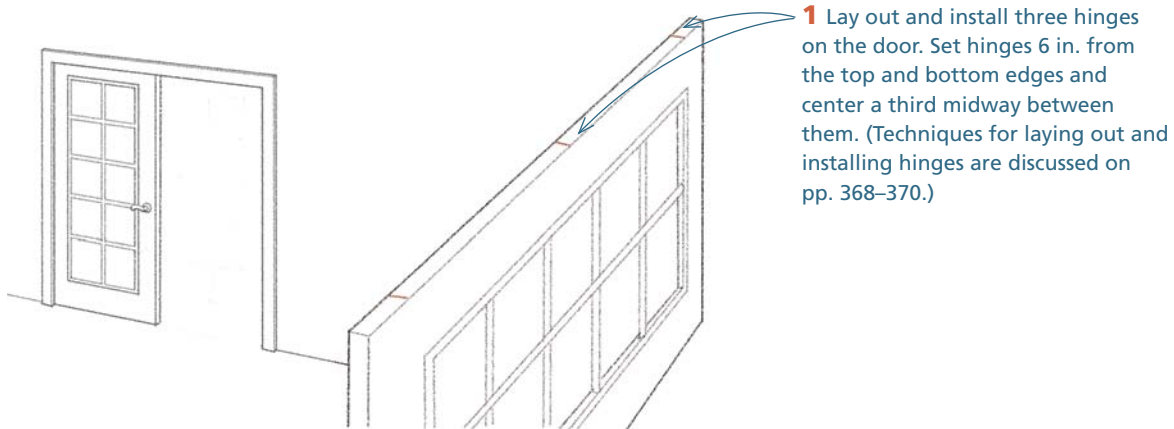

1 Lay out and install three hinges on the door. Set hinges 6 in. from the top and bottom edges and center a third midway between them. (Techniques for laying out and installing hinges are discussed on pp. 368–370.)

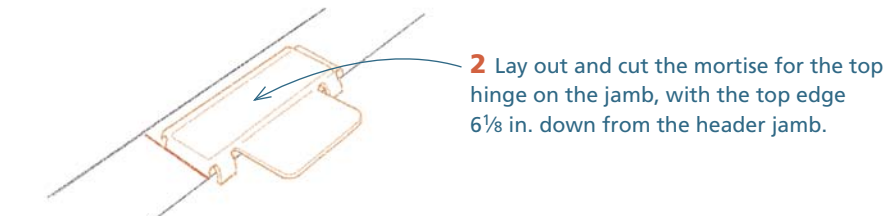

2 Lay out and cut the mortise for the top hinge on the jamb, with the top edge $6\frac{1}{8}$ in. down from the header jamb.

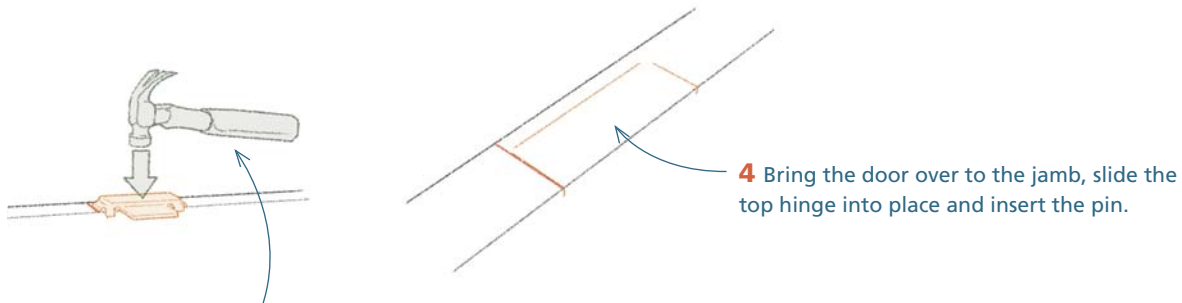

4 Bring the door over to the jamb, slide the top hinge into place and insert the pin.

3 Remove the pin from the top hinge on the door and install the loose leaf in the mortise you just cut on the jamb.

5 With the door hanging from the top hinge, open the bottom and middle hinges and mark their locations on the jamb.

6 Take the pin out of the top hinge and set the door aside. Cut mortises for the two lower hinges in the jamb.

7 Bring the door back over to the jamb, reset the pin in the upper hinge, fold the lower hinges into the mortises and screw them to the jamb.

STEP 4 Hang the active door

Swing open the fixed door. Install the active door on the opposite side of the opening, using the procedure described in step 3.

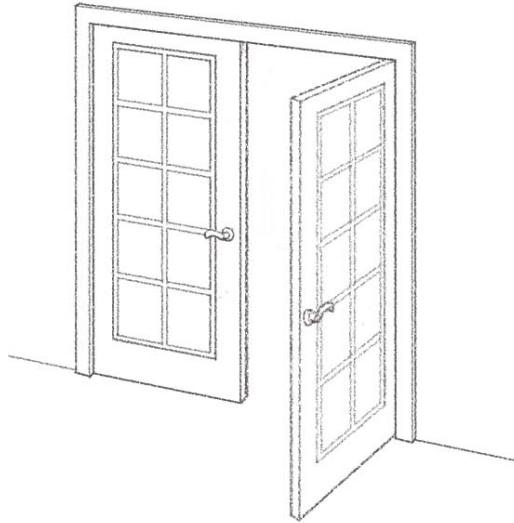

STEP 5 Fit the doors to each other

1 Swing one door into the closed position, and mark along the outer edge of the door on the top jamb.

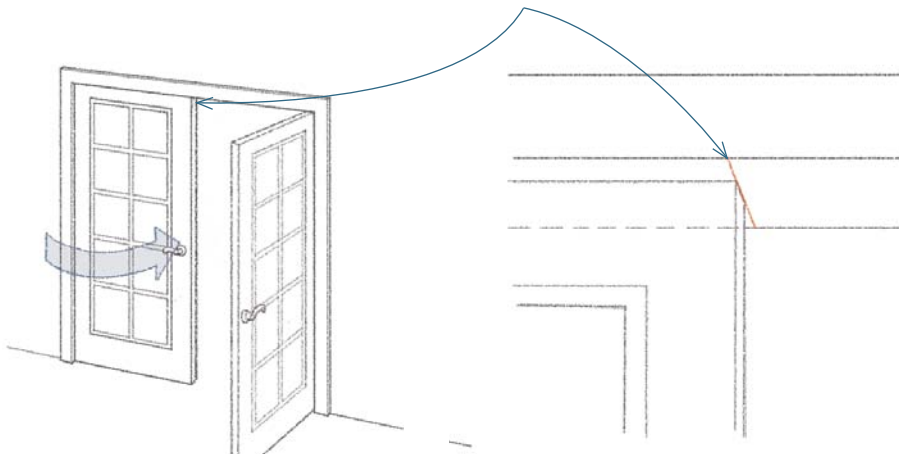

2 Swing in the other door, and mark it in the same way.

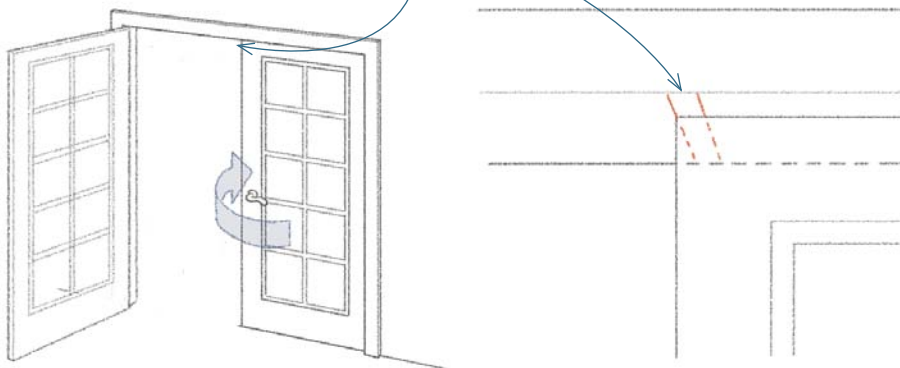

3 Mark the center point of the space between the two marks.

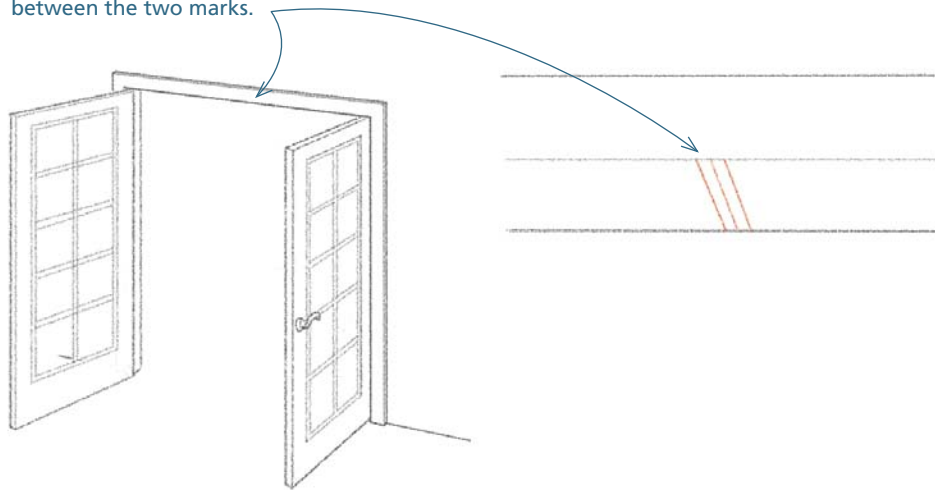

4 Swing the fixed door closed, and transfer the center point from the jamb to the top of the door. With the door held in this position, use a laser, a plumb bob, or a reliable level to mark a plumb line down from this mark.

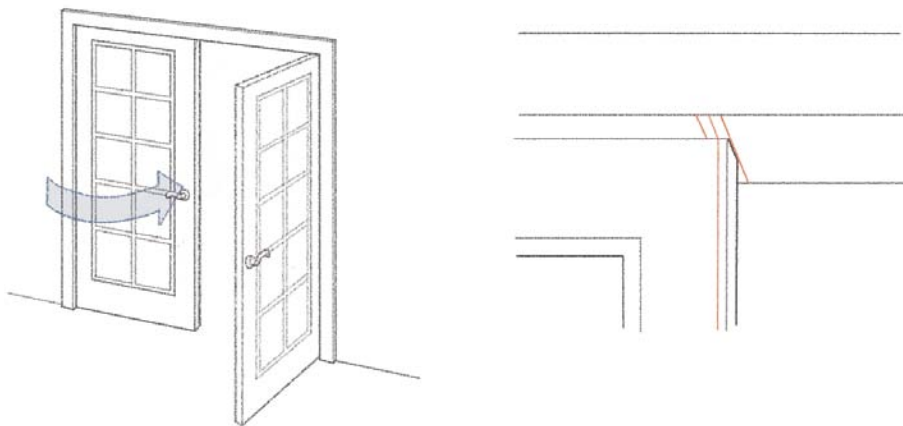

5 Remove the door from the hinges, and place it across a pair of sawhorses. Cut along the line using a circular saw and a guide. Do not bevel this edge.

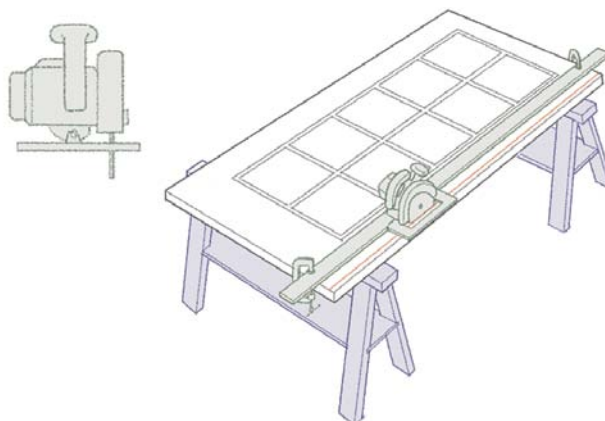

STEP 5 Fit the doors to each other (continued)

6 Swing the active door into the closed position. (Use a toolbox or other heavy item to keep it from swinging past the closed position.)

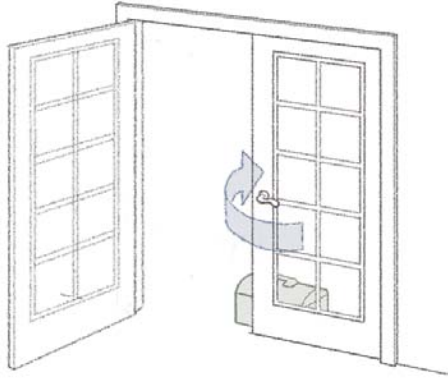

7 Swing the fixed door until it overlaps the active door. Scribe along the edge of the fixed door to mark the edge of the active door.

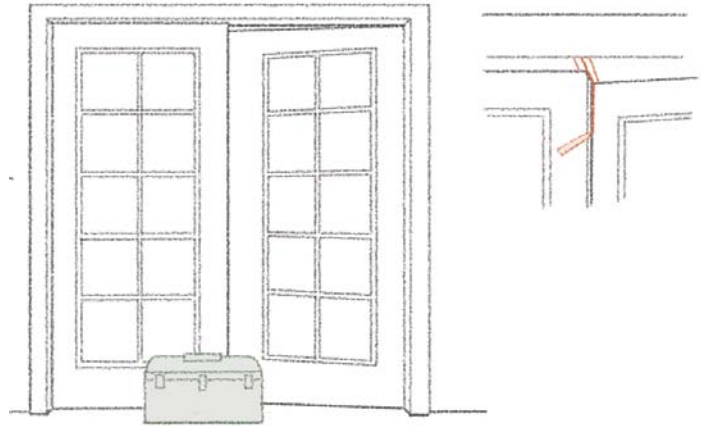

8 Remove the door from the hinges, and set it across a pair of sawhorses. Set your circular saw to a 3° bevel, and, using a saw guide, cut along the line. Reinstall the door, and carefully mark it for final planing.

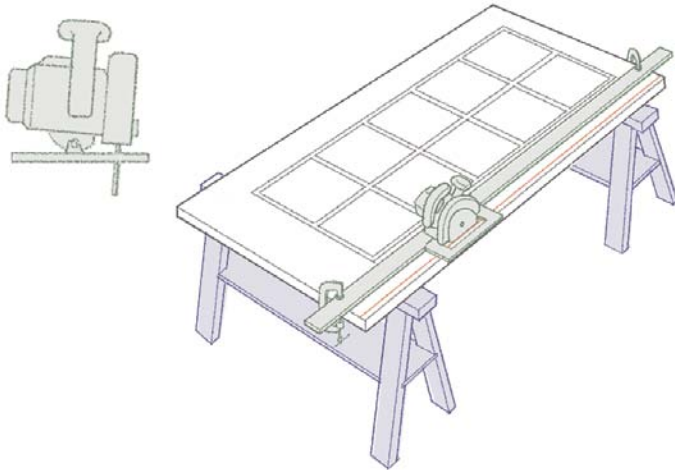

9 Remove the door again, and secure it on its edge. Plane it precisely to the marks.

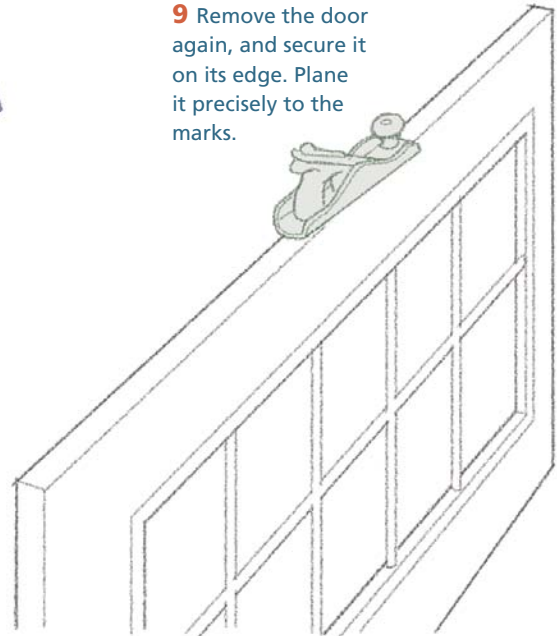

STEP 6 Install the hardware

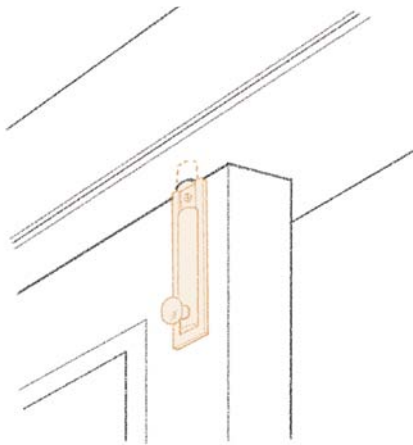

1 There are two kinds of slide bolts used to hold the door in a fixed position. The first is a surface bolt. Installation is straightforward, but it can be difficult to install the catch at the top of the door gracefully. If it's mounted on the hinge-pin face of the door, the bolt will have to slide into the edge of the casing; if it's on the other side of the door, the doorstop will have to be notched to accommodate the bolt.

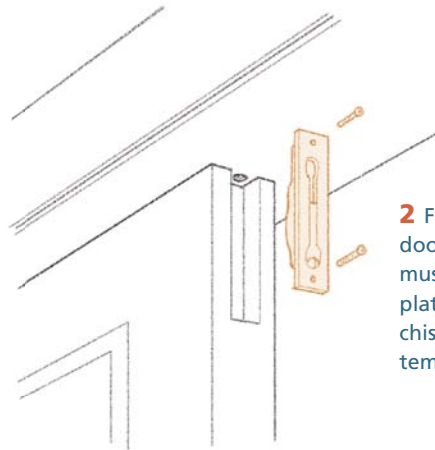

2 Flush bolts are mounted on the door edge. To install these, you must cut a mortise to house the plate of the assembly. Use either a chisel and hammer or a router and template to cut this mortise.

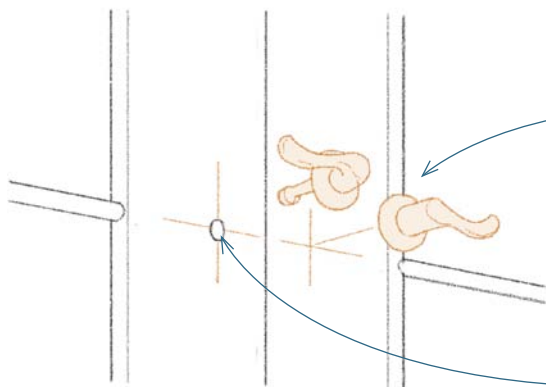

3 Closure hardware for double doors consists of a "dummy" knob or handle on the fixed door and a pair of regular operating handles with a latch bolt assembly on the active door. Opposite the latch bolt assembly, there also is a latch hole covered by a strike plate on the edge of the fixed door. Screw the dummy handle to the face of the door.

4 Install the latch bolt assembly and the doorknobs using the procedure described in the previous section.

5 After installing the closure hardware on the active panel, close the door until the bolt just touches the fixed panel. Mark the top and bottom of the bolt.

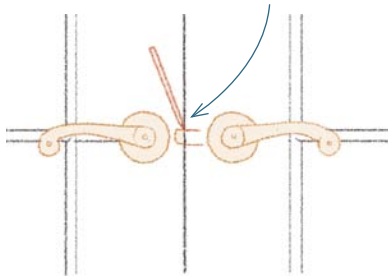

6 Drill the latch hole in the edge of the fixed door.

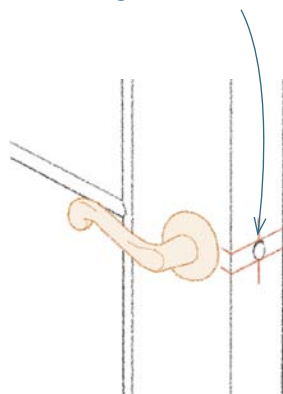

7 Hold the strike plate in the right position, and mark the perimeter. Cut a mortise, and install the latch plate.

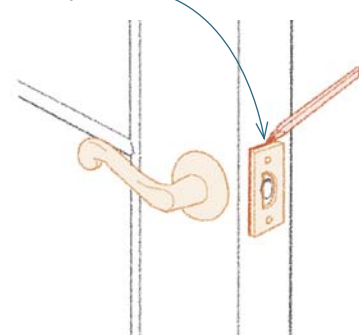

STEP 7 Install the stop molding

1 Swing the door closed, and hold it so that the hinge-pin face is flush with the corner of the casing. Mark the casing along the doorstop face of the door.

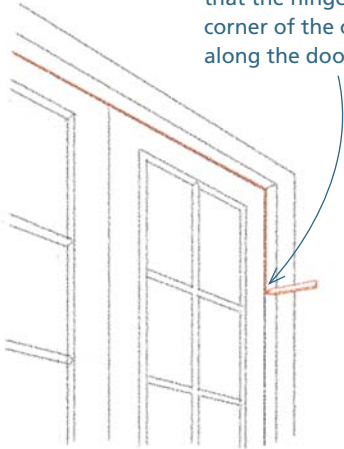

2 Install the stop molding $\frac{1}{16}$ in. from the line with a minimal number of nails.

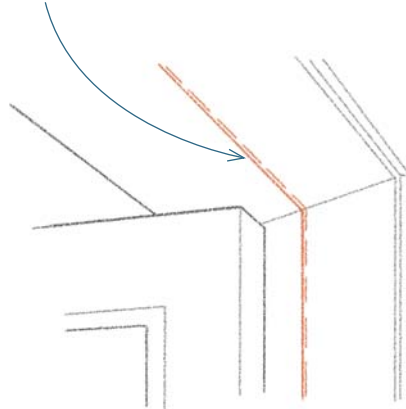

3 Close the door to check the fit. Adjust the stop, if necessary. When you get a satisfactory fit, finish nailing off the stop.

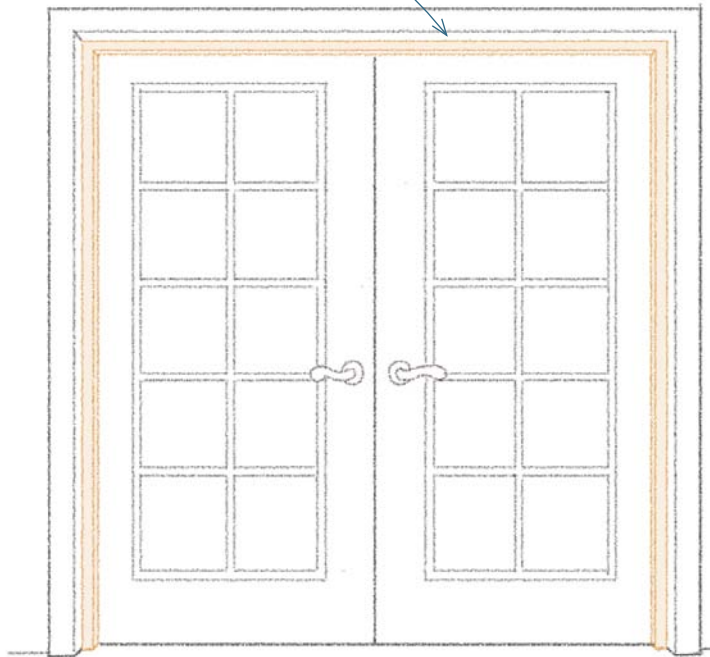

Installing Pocket Doors

Pocket doors roll on wheels attached to the top of the door that fit in an overhead rail. To open the door, you slide it into a slot or “pocket” in the wall adjacent to the door opening. The key parts for pocket doors come in kits that can be cut to match the size of the door or doors that you are using. Although these kits are made for 2x4 interior walls, the wall can be thickened, both to stiffen it and to make room for shallow electrical outlets. Because different manufacturers have slightly different systems, make sure you read the directions that come with the specific kit you’re installing. This section provides step-by-step procedures for installing a typical pocket-door assembly.

STEP 1 Build an oversize rough opening

2 Because the door is suspended from an overhead rail, the height of the rough opening must also be oversize. A common requirement is 4½ in. taller than the height of the door. Heavy-duty kits sometimes require a slightly taller opening.

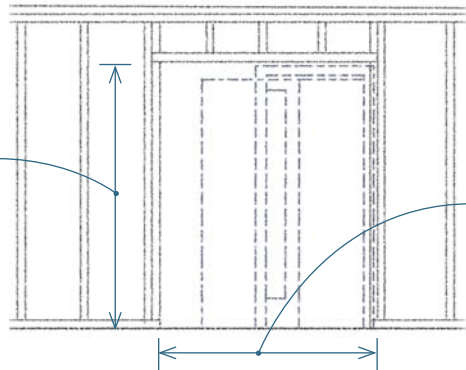

1 The rough opening for a pocket typically has to be twice the width of the door plus 1 in.

STEP 2 Hang the rail assembly

Rail assemblies come ready to install when you’re using common door sizes. If you have to alter the rail assembly, just follow the instructions included with the kit.

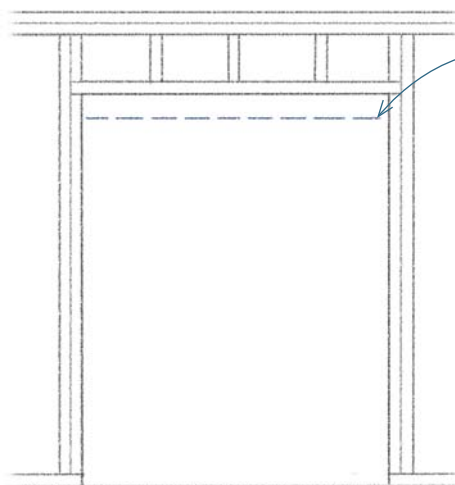

1 The rail assembly should not be installed to the underside of the header of the rough opening; rather, it should be hung on the sides of the rough opening, below and independent of the header. This ensures that the rail will be straight and will not be affected by any downward settlement of the rough opening header. The correct height of the rail assembly depends both on the pocket-door kit you’re using and on the thickness of the floor covering, which will be installed later. Read the directions that come with the kit.

STEP 2 Hang the rail assembly (continued)

2 Check the instructions for the correct height of the rail, measure this distance from the floor on each trimmer stud, and use a square to mark lines perpendicular to the edge of the trimmer stud at the marks.

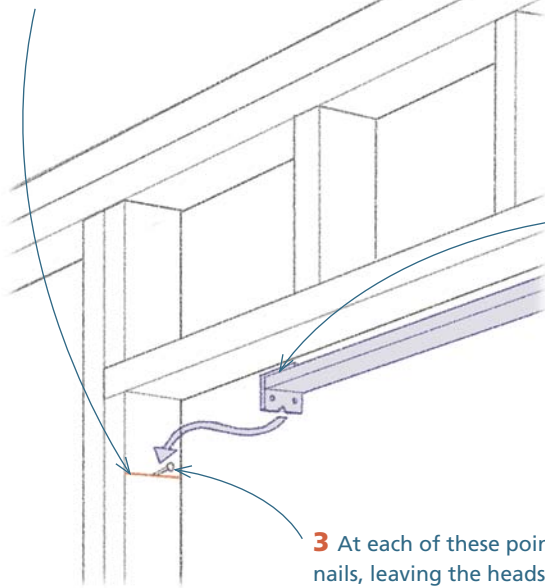

3 At each of these points, drive in 12d common nails, leaving the heads of the nails about $\frac{1}{4}$ in. proud of the surface. The ends of the rail assembly are notched. When the tops of the notches seat against the incompletely driven nails, the assembly is at the correct height.

4 After setting the assembly on the nails and squaring the brackets up with the sides of the openings, drive two more nails through the holes in the brackets. Then, drive the two gauge nails home.

WAYS OF WORKING

Important Things to Know about Pocket Doors

There are three important differences between hanging pocket doors and other kinds of doors.

- A pocket door requires a much larger rough opening than other kinds of doors of the same size.
- Pocket doors must be installed much earlier in the building sequence than other doors. Most

of the work of hanging a pocket door must be done before you hang the drywall.

- The jambs on two sides of the opening must be split with the door set between the two halves. On one side of the door, the half-jamb must be removable.

STEP 3 Install the split jambs

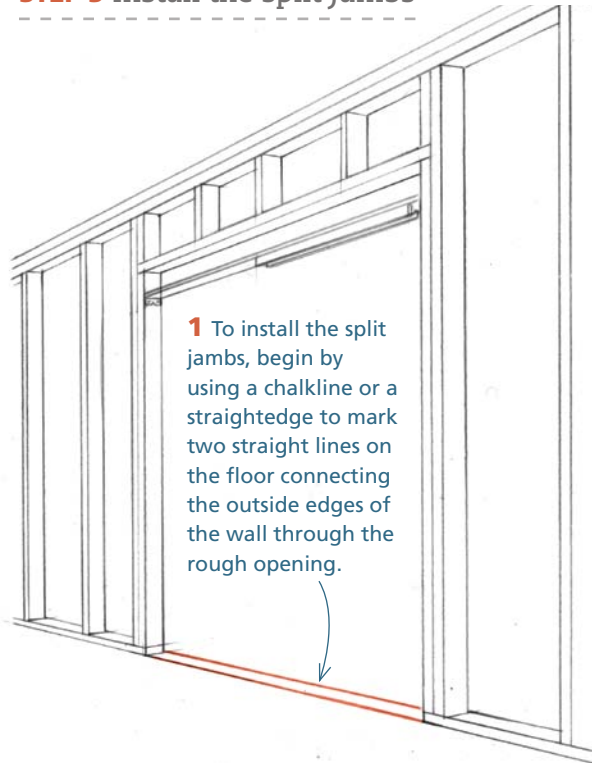

Typically, the pocket for the door is created by two pairs of split jambs. These are usually made up of 1x3s that are clad on three sides by steel. The steel cladding is used both to help hold the pieces straight and to protect the pocket from protruding fasteners.

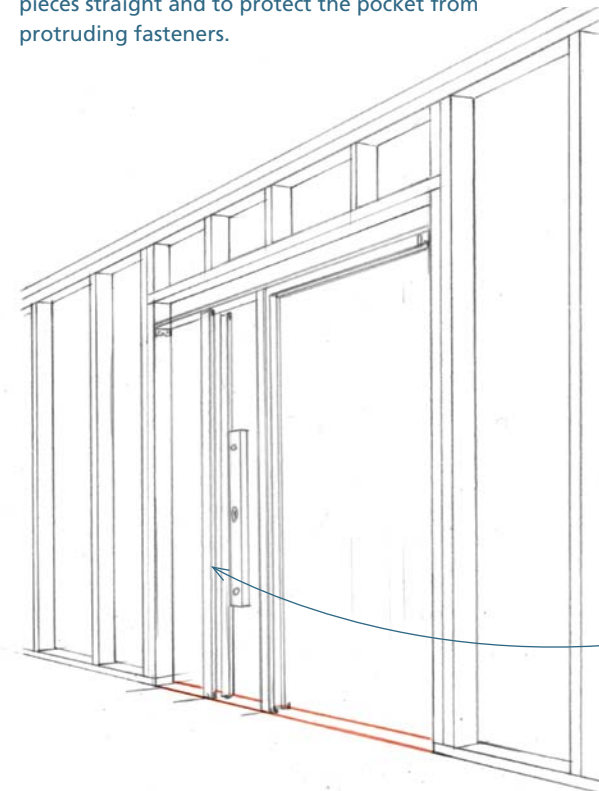

4 Hold the tops of the split jambs against the shoulder, and attach them to the wood part of the assembly (above the rail) with one screw per piece. Hold a level against the edge of the split jamb assembly, and move the bottom until the level reads plumb. Drive nails through the holes in the bracket and into the floor. After you get the bottom attached, drive in a second screw on both pieces at the top.

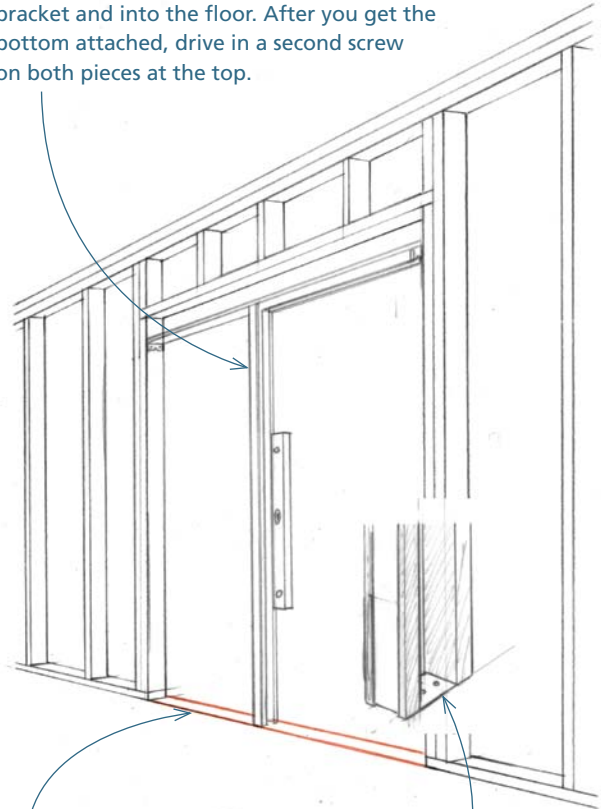

5 Find and mark the center of the space between the split jamb you've just installed and the end of the rough opening on the pocket wall side. Install a second split jamb at this location using the procedure just described.

3 Insert the bottom ends of the two split jamb pieces into the metal floor brackets that come with the kit.

STEP 4 Hang the door

1 Hangers that suspend the door from the railing are two-part mechanisms. The first part is a plate that you screw to the top of the door.

2 Although the instructions generally call for these to be placed 2 in. to 3 in. from the ends of the doors, it's better to place them just in from the stiles on paneled doors because the attachment screws will not be in end grain. Make sure you install these with the lock tab facing the same side of the door.

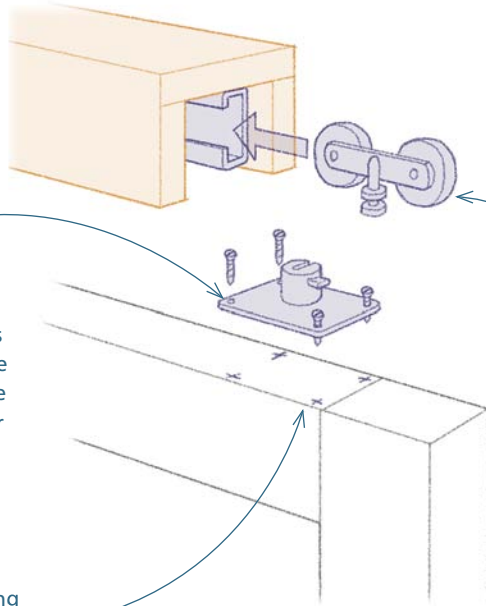

3 The second part is a roller that fits in the rail. Insert the two rollers into the rail through the gap at the latch-side end of the rail. If the rollers have three wheels, alternate the side that has two wheels as you place them in the rail.

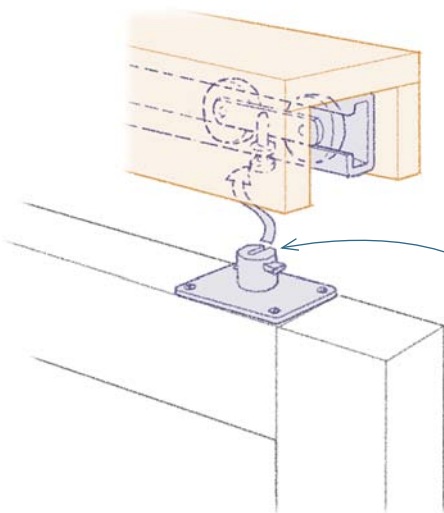

4 Align the rollers near the plates on the door, and lift the door. At each roller, slide the pin at the bottom of the roller into the slot in the door plate. Rotate the lock tab on the door plate over the pin to lock it in place. Check the fit and operation of the door. Make sure there will be enough space under it to install the floor and that it rolls smoothly.

When you're satisfied with the fit, remove the door by undoing the lock tabs and sliding the pins in the slots in the door plates. Store the door in a safe place until the drywall is finished.

TOP TIP

Use Screws in Key Locations

Although you can nail most of the parts of a pocket door together, it's often better to use screws. For attaching the split jambs to the rail assembly, predrill and screw to avoid splitting the jamb or bending the rail. To attach the drywall to the split jambs, use 1-in. screws. Finally, always use screws to attach at least one side of the finished jambs so that you'll be able to remove the door in the future.

STEP 5 Hang and finish the drywall

Rip a piece of 2x4 about 4 ft. long to a width of $2\frac{1}{8}$ in.—the width of the pocket. Slide this board into the pocket, and hold it horizontally as another person hangs the drywall. The board supports the somewhat fragile split jambs during this process. Use screws rather than nails to fasten the drywall, and make sure screws are no longer than 1 in. It is important to avoid having any fastener protrude into the pocket.

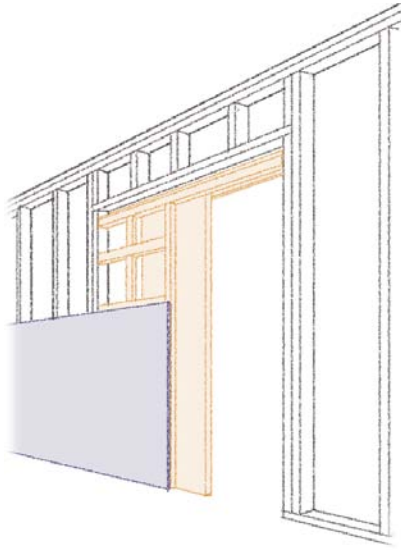

STEP 6 Install the trim

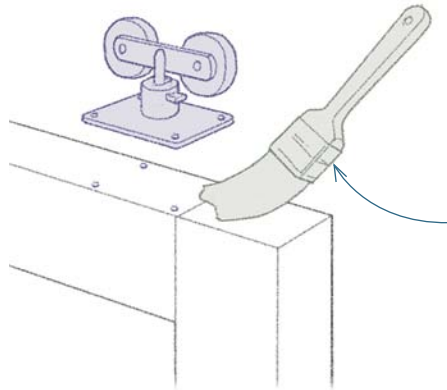

1 Remove the door plates, prime or seal all four edges of the door, and reinstall the plates. Prior to sealing the top of the door, take off the door plates; reinstall them when the sealer dries. Make sure the lock tabs of both plates face the same side of the door.

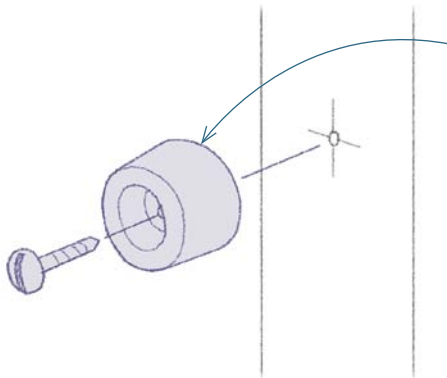

2 Fasten a bumper on the back edge of the door about 40 in. from the bottom. Rehang the door using the procedure described in step 4.

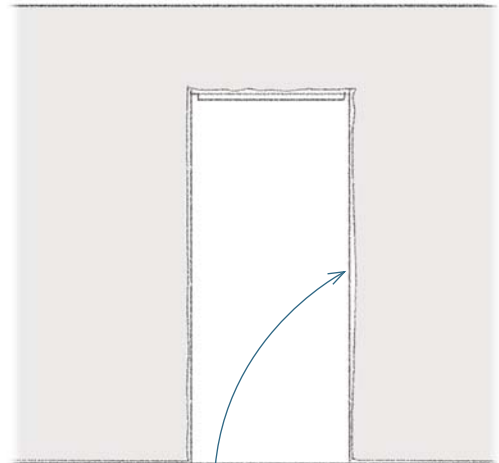

3 The finished jamb on the latch side is one solid piece. Cut and install this piece so that it extends up to the underside of the rail assembly. Use shims to make it plumb and straight, and attach it with finish nails as you would any piece of trim.

STEP 6 Install the trim (continued)

4 On the pocket side, install the split finished jambs. These need to be ripped wide enough to cover the edge of the drywall and the rough jamb. And they need to extend from the floor to the underside of the rail assembly.

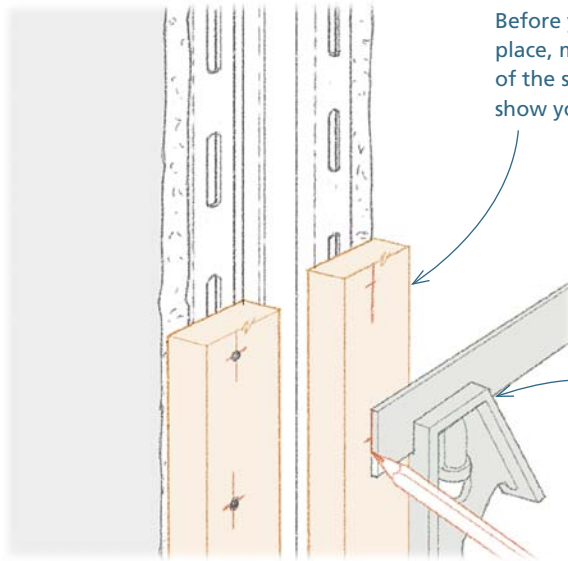

5 Nails need to hit the slots in the steel on the side of the rough split jambs. Before you set the finish jamb pieces in place, mark the height of the centers of the slots on the surface. These marks show you the height of the slots.

6 To get the location right along the width of the jambs, set a combination square to the depth of the centers of the slots with the fence of the square resting on the face of the drywall. Use a pencil to transfer this distance to the jamb.

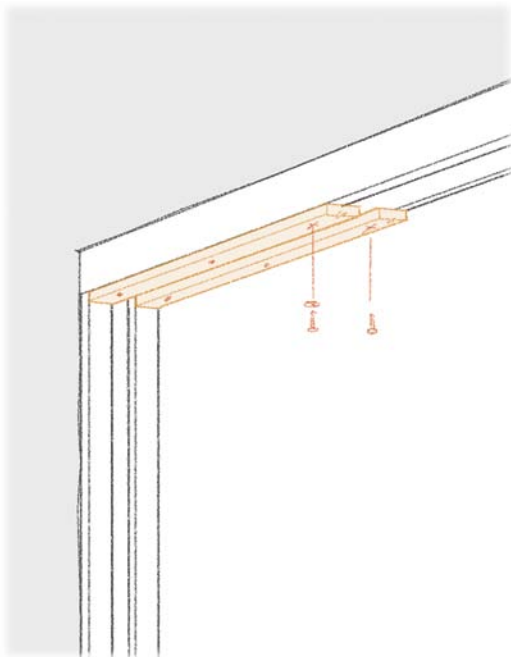

7 The jamb along the header is also a split jamb. One side—the same as the side that the lock tabs are on—has to be removable so the door can be taken off if necessary. Use screws on the removable side of the split jamb. One graceful way to do this is to use brass oval-head screws with decorative washers. Nails are OK for the other side. Always put the head jamb on after the side finished jambs, which aids disassembly.

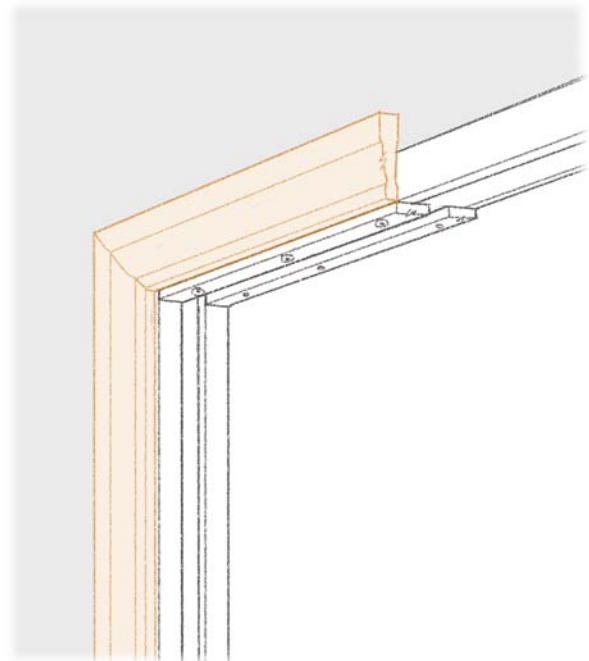

8 Lay out the reveal for the casing so that it covers one-half or less of the head casing. This makes it easier to access the hangers later. Use nails that will not protrude into the pocket or hit the rail. On a standard 2x4 wall, the nails usually need to be 1½ in. to 1¾ in. long. Along the removable half of the header jamb, make sure you don't attach the casing to the jamb.

STEP 7 Finish the job

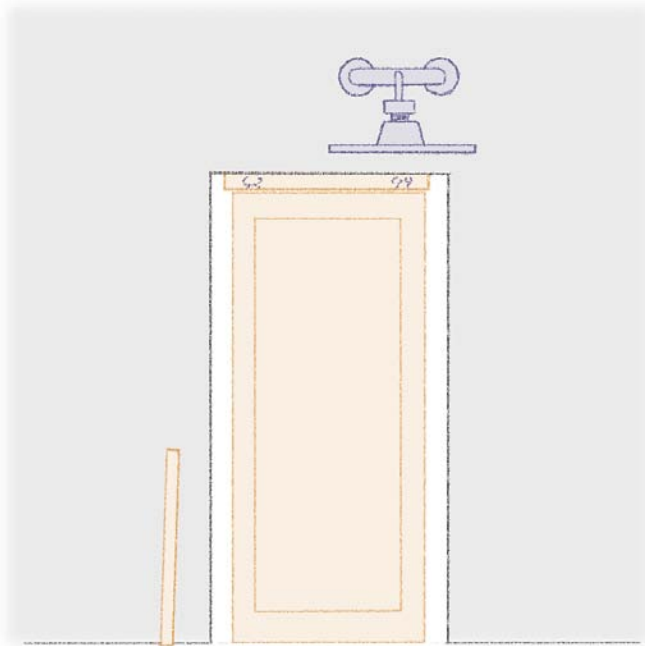

1 Take off the removable jamb at the header. Slide the door until it's almost closed, and adjust the hangers until the front edge of the door is even with the latch side jamb.

2 Mark the door for the closure hardware you are using. Undo the lock tabs, and take the door off the rail. Install the hardware on the door according to the directions that come with the hardware. After you install the hardware, you may want to immediately remove it and paint or stain the door before rehanging it.

3 Reinstall the door and the removable jamb, and make sure you're satisfied with the fit and operation of the door. Install latch hardware on the jamb, if necessary. Finally, install the plastic guides that come with the door at the bottom of the split jamb.

Installing Bifold Doors

As the name suggests, bifold doors fold in half as they're opened. To do this, they use a combination of pins, hinges, and an overhead track. There are two separate stages for the installation of bifold doors. First, you have to build a finished opening the correct size, and, second, you install the hardware and hang the doors. This section provides a step-by-step procedure for building a cased opening and installing a pair of 48-in.-wide by 79-in.-tall bifold doors. A cased opening is the most common configuration, but you can also install bifold doors in an opening that is finished in drywall only.

STEP 1 Build the rough opening

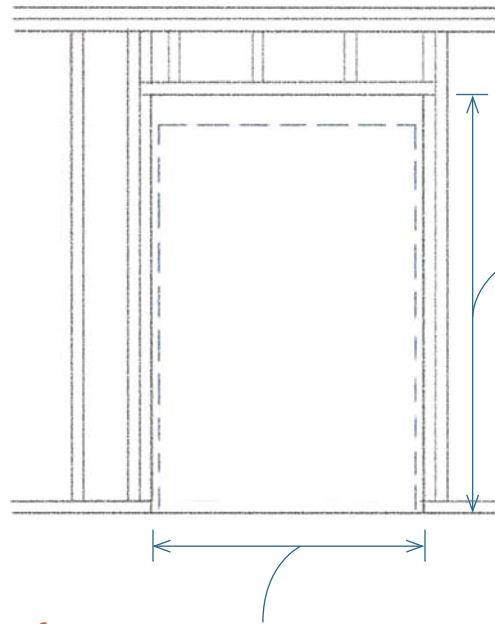

1 The required width of the rough opening for bifold doors installed within a cased opening is usually the nominal dimension of the doors plus 2 in.

2 The required height depends on the size of the door panels. For a bifold with 77-in.-tall door panels, make the height of the rough opening 80½ in. above the subfloor; for a bifold with 79-in.-tall panels, make the height 82½ in. After the drywall has been hung and finished, proceed to step 2.

STEP 2 Determine the size of the finished opening

Before putting together the jamb assembly, you have to know the exact dimensions of the finished opening. There are two variables: the size of the door panels and the thickness of the floor covering.

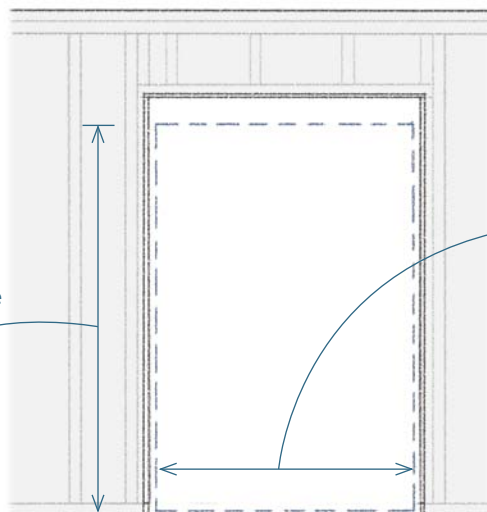

2 The height of the finished opening normally should be the height of the door panel plus 1¼ in. above the top of the finished floor.

1 The width of the finished opening is usually the same as the nominal width of the set of doors. For a 48-in. set of doors, for example, make the finished opening exactly 48 in. wide.

Make sure you take into account the anticipated thickness of the floor covering when you calculate the height of the opening.

If, for example, you're using 79-in.-tall door panels and you plan on adding ¾-in.-thick hardwood flooring, you need to add $79 + 1.25 + 0.75$. In this case, you should make the height of the finished opening 81 in. off the top of the subfloor.

STEP 3 Install the jamb

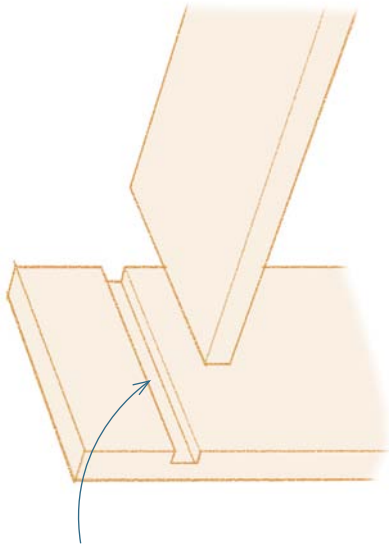

1 Preformed jambs often have a $\frac{3}{8}$ -in.-deep by $\frac{3}{4}$ -in.-wide rabbet to help align the head jamb with the side jamb at the correct height.

2 With a $\frac{3}{8}$ -in.-deep rabbet, cut the header $\frac{3}{4}$ in. longer than the desired width of the finished opening to account for the depth of the rabbets.

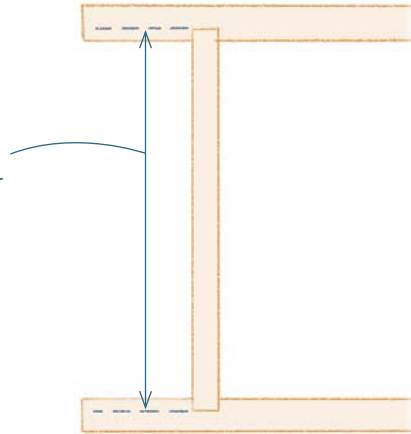

Many preformed jambs are cut to a length of 81 in. below the rabbet. If so, there's no need to cut the side jambs to length. If the jamb material is longer, cut it to 81 in. below the rabbet now.

3 Arrange the pieces on edge on the floor, and set the header jamb in the rabbets of the side jambs.

4 Drive three screws or nails through each side jamb and into the edge of the head jamb to build the three-piece jamb assembly.

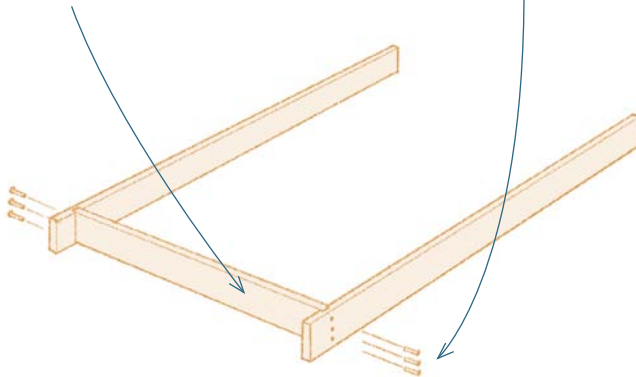

5 Attach stops that are flush with one face of the wall and project into the door opening. Attach these scraps close to the edge so the screw holes will be covered by the casing.

Place stops about 1 ft. from the top and bottom of each side.

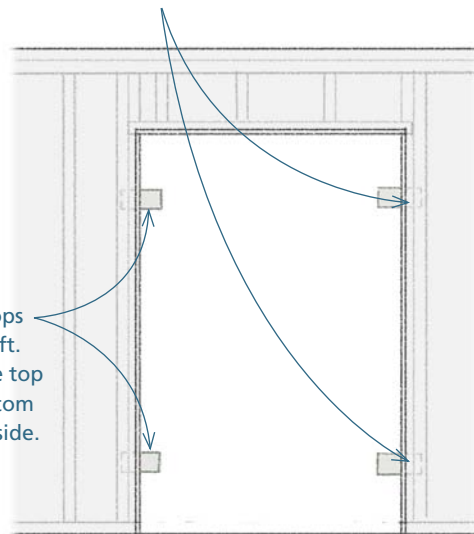

STEP 3 Install the jamb (continued)

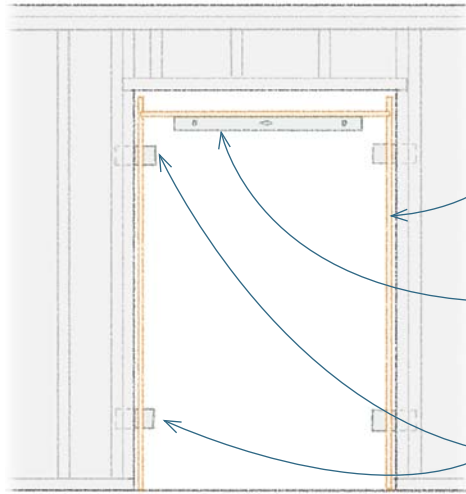

6 Place the jamb assembly in the opening, and push it against the stops you've just installed.

7 Check the header jamb with a level. If one side is higher than the other, begin the installation on that side.

8 On the side jamb on the high side, predrill and drive in a couple of 8d finish nails as you hold the jamb snug to the stops. Leave nails projecting about $\frac{1}{4}$ in. so you can remove them easily if need be. Place one nail about a foot from the top and the other about a foot from the bottom.

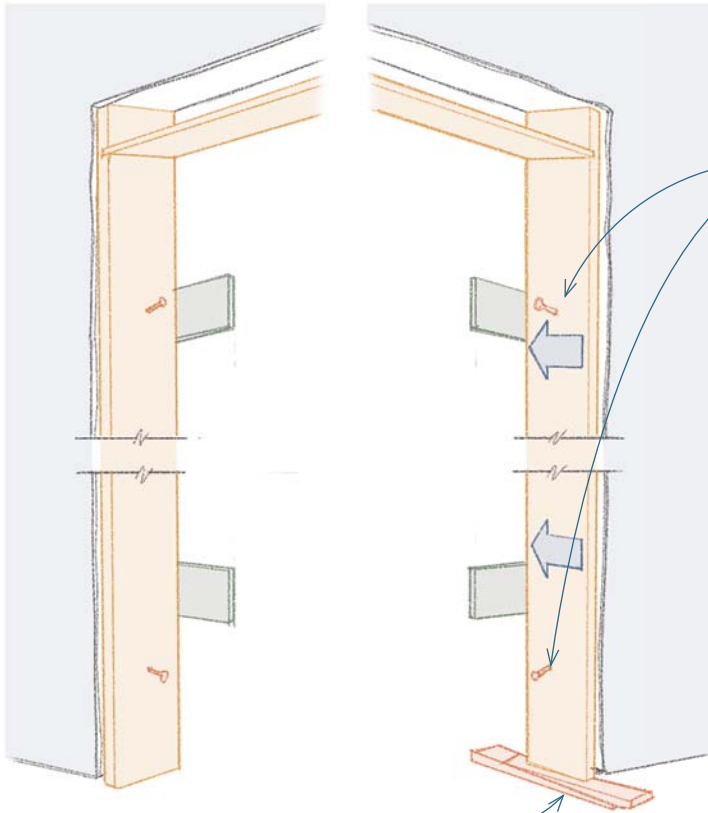

10 When you get the header level, temporarily attach the side jamb. As on the first side, press the side jamb against the stops, predrill, and drive a couple of nails in partially to hold the jamb in place.

9 Slide shims under the bottom edge of the other side jamb. Tap the shims in while checking the header for level.

11 Use a thin pry bar to lever the jambs away from the trimmers as you center the assembly roughly in the opening. Double-check the header for level, and make sure the side jambs are still against the stops.

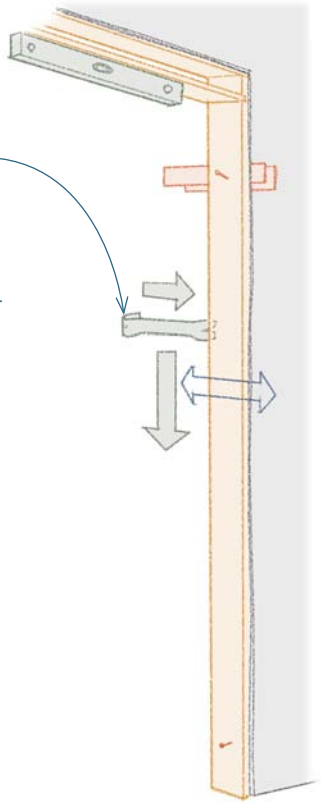

12 Permanently attach the jambs with nails and shims, checking frequently for plumb, level, and straightness as you go. Place pairs of shims every 20 in. or so on the sides. Place one pair of shims about 2 in. in from each end of the header jamb (to shore up the area where the pivot pin will be) and one pair near the center. Remove the stops.

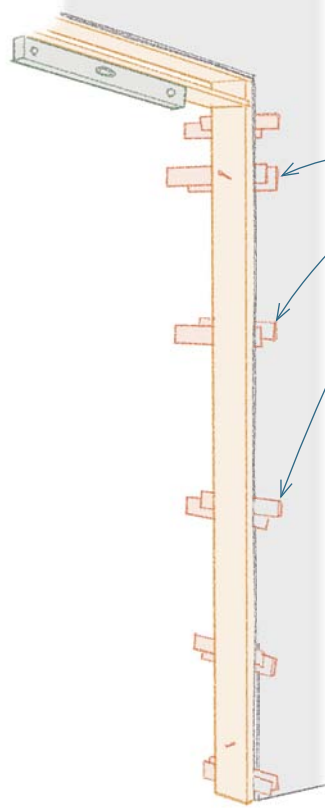

STEP 4 Install the casing

Install three pieces of casing on each side of the wall using the same techniques you would use for any door or window.

STEP 5 Install the jamb brackets and track

A 48-in.-wide door assembly typically consists of two bifold doors, with each door having two panels. In such a four-panel installation, there are two jamb brackets, one on each side of the opening. Both the sequence and the exact procedure for installing the jamb brackets depend on the floor covering. If you plan to use hardwood, vinyl, or tile for the finished floor, wait until after those materials are installed, then install the jamb brackets on top of them.

1 If carpet is planned, install the brackets before the carpet. Start by installing blocks of plywood where the brackets will go. These raise the brackets up so that they'll clear the surface of the carpet. For most carpets, you can use 1/2-in. plywood. Make the blocks about 1/4 in. wider and longer than the jamb brackets. Carpet should be installed around the blocks.

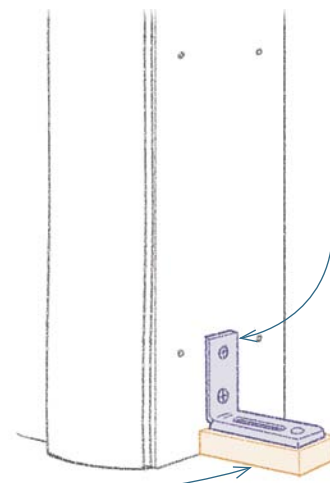

2 Center the bracket on the jamb. Screw the vertical portion of the bracket to the jamb and the horizontal part to the floor.

STEP 5 Install the jamb brackets and track (continued)

3 Find the center of the head jamb and mark a line.

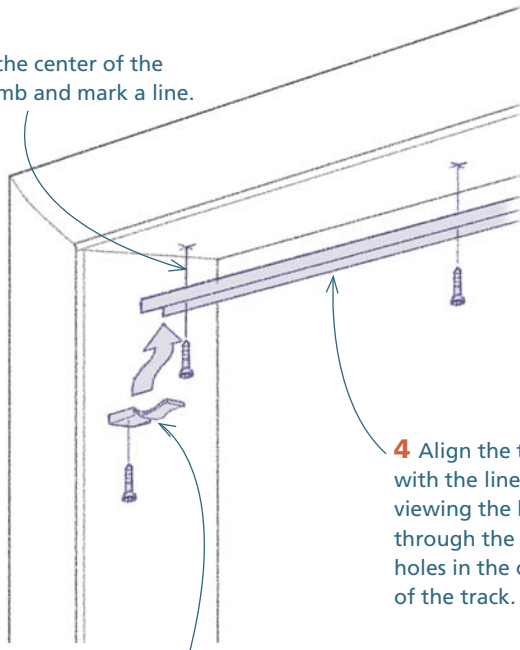

4 Align the track with the line by viewing the line through the screw holes in the center of the track.

5 In a four-panel assembly, there are pivot brackets at each end of the track. Sometimes you need to move a top pivot bracket to access the screw hole at the end of the track. To move the bracket, loosen the screw that clamps it in place, and slide the bracket down the track and out of the way. After screwing off the track, slide the bracket back toward the end of the track, and clamp it in place by tightening the screw.

STEP 6 Install the doors

1 Tap the three pivots into the holes in the door.

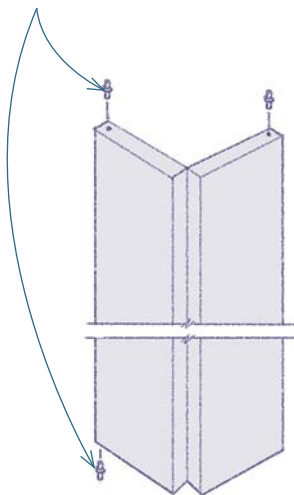

2 With the door partially folded together and the bottom tilted toward the center of the opening, thread the top pivot into the top pivot bracket and the guide pivot (or roller) into the track.

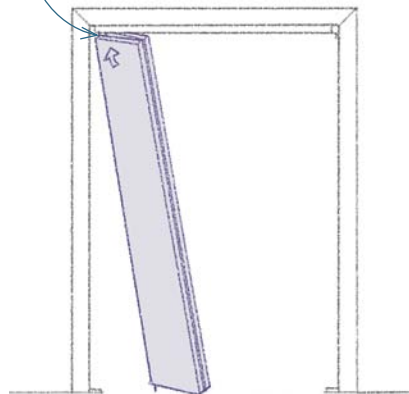

3 Swing the bottom of the door over the jamb bracket, and lower the bottom pivot onto the lower bracket. Slide the door closed.

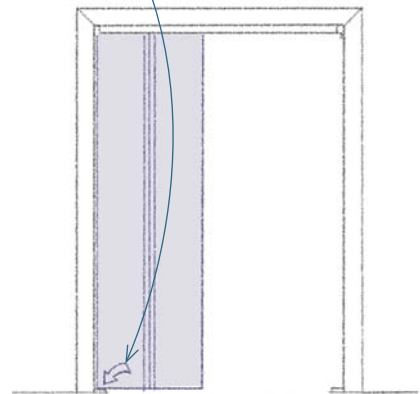

TOP TIP

Why Preformed Jamb Are Oversize and Beveled

.....
Most building-supply stores have 4⁹/₁₆-in.-wide preformed jamba. These jamba are ¹/₁₆ in. wider than the nominal thickness of a 2x4 interior wall, which is 4¹/₂ in. Another feature of these preformed jamba is that the edges are beveled slightly. This shape is designed to make it easy to get a tight joint where the casing fits against the jamb.
.....

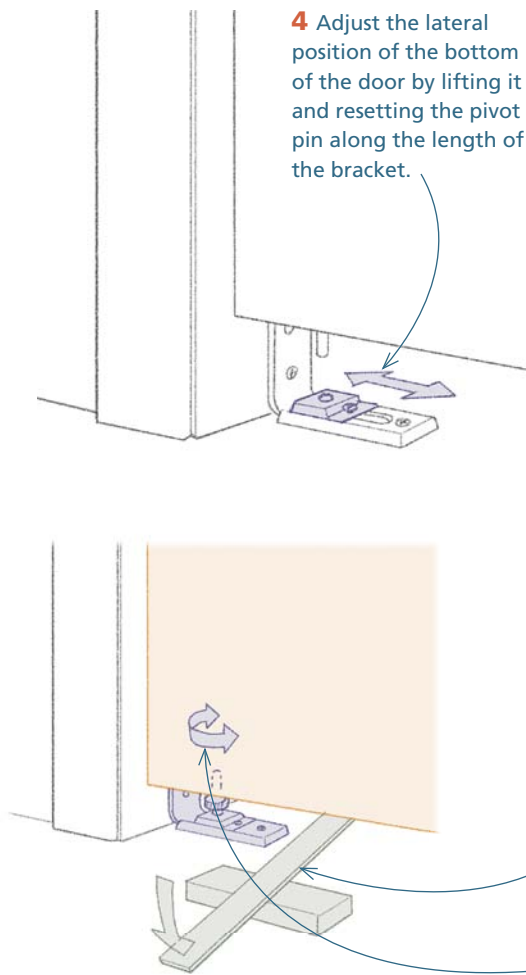

4 Adjust the lateral position of the bottom of the door by lifting it and resetting the pivot pin along the length of the bracket.

5 Adjust the lateral position of the top of the door by sliding the top pivot bracket in the track. You can leave the door pin in the bracket as you make this adjustment, but you have to slide the door into the open position to access the clamping screw.

Before opening the door, mark the position of the end of the pivot bracket on the track. Estimate how much lateral movement will be necessary to get the door in line with the jamb, and make a second mark on the track that marks that distance. Open the door, loosen the clamping screw, and slide the bracket down to the second mark. Tighten the screw, close the door, and see how the door now aligns with the jamb. If further adjustment is necessary, repeat the process; you may also want to readjust the bottom laterally.

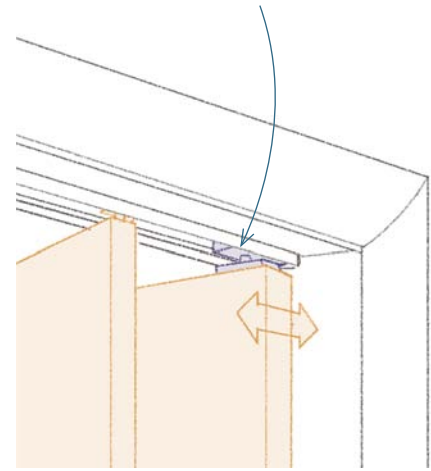

6 To adjust the height of the door, lift the door until the bottom pivot is just clear of the bracket. One way to lift the door is with a flat bar and fulcrum.

7 Turn the pin clockwise to raise the door or counterclockwise to lower it. Adjust the door until the top is parallel with the track, with a $\frac{1}{8}$ -in. to $\frac{1}{4}$ -in. space between the two. Make sure the door pivots without hitting the jamb and there's a consistent $\frac{1}{8}$ -in. to $\frac{1}{4}$ -in. gap between the edge of the door and the jamb in the closed position.

STEP 7 Finish the job

Clip the snigger guide into the track near the center of its length.

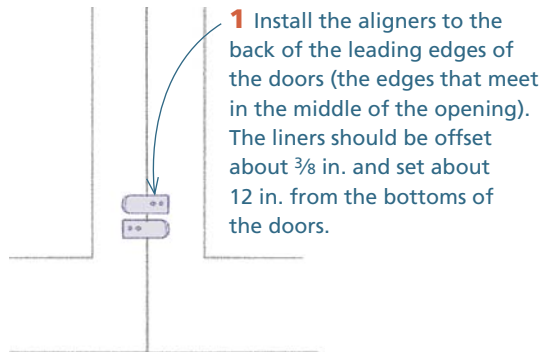

1 Install the aligners to the back of the leading edges of the doors (the edges that meet in the middle of the opening). The liners should be offset about $\frac{3}{8}$ in. and set about 12 in. from the bottoms of the doors.

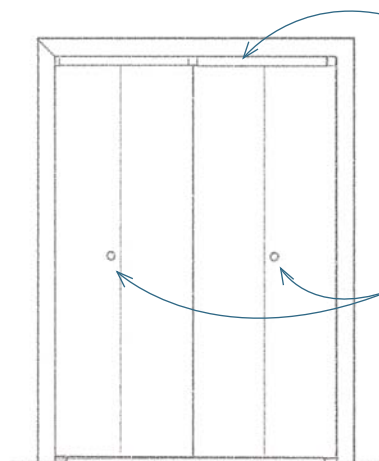

2 Install trim to cover the gaps between the doors and the side jambs and to conceal the track. (These pieces of trim are optional and not often used.)

3 Install the doorknobs. Place these near the center of each door (near the hinges that the door folds on). This placement maximizes the leverage for pulling the door open.

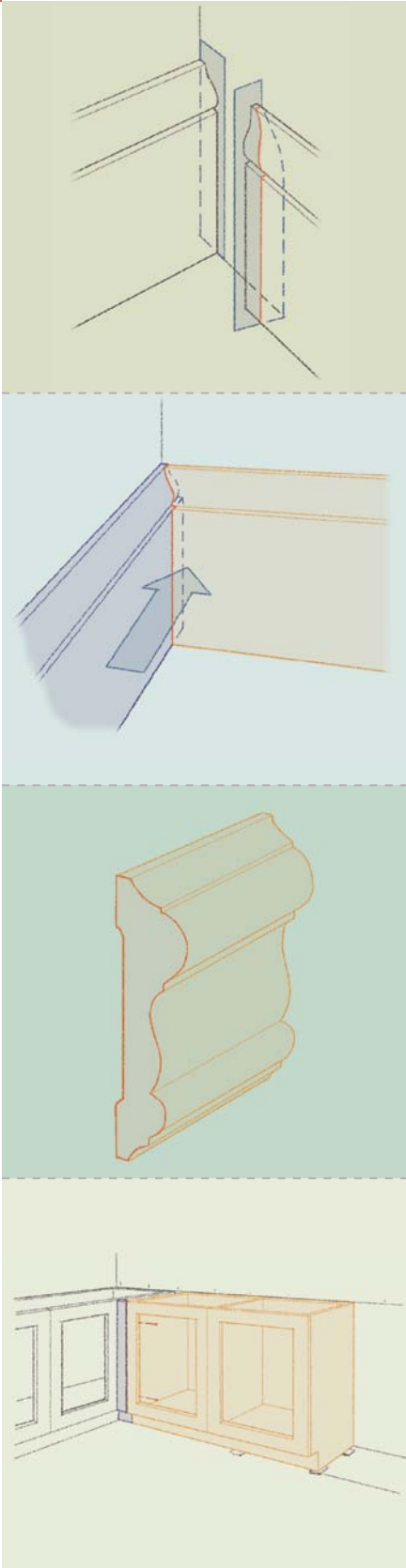

Installing Trim and Cabinets

AFTER HANGING THE DOORS, carpenters install trim and hang cabinets, a process that is generally referred to as finish carpentry. Custom millwork companies fill thick catalogs with molding profile options. In most houses, however, the trim can be divided into two general categories: door and window trim and baseboard molding. While these trim systems serve a practical function, they are also exploited for aesthetic purposes. Window, door, and baseboard trim treatments, in fact, often play a major role in defining the character and style of the inside of the house.

In addition to these common and necessary trim systems, many houses also feature chair rail molding and crown molding. Unlike door and window trim and baseboard molding, these traditional trim treatments are rarely necessary. In most cases, they're used purely for decorative purposes.

Installing Door Casing

Although prehung interior doors usually come with the casing attached, there are almost always some doors inside the house that require casing. Exterior doors and the interior doors in a variety of custom design schemes, for example, usually require the on-site installation of casing. The steps on the following pages describe a method for fitting and installing a typical door casing.

● INTERIOR TRIM

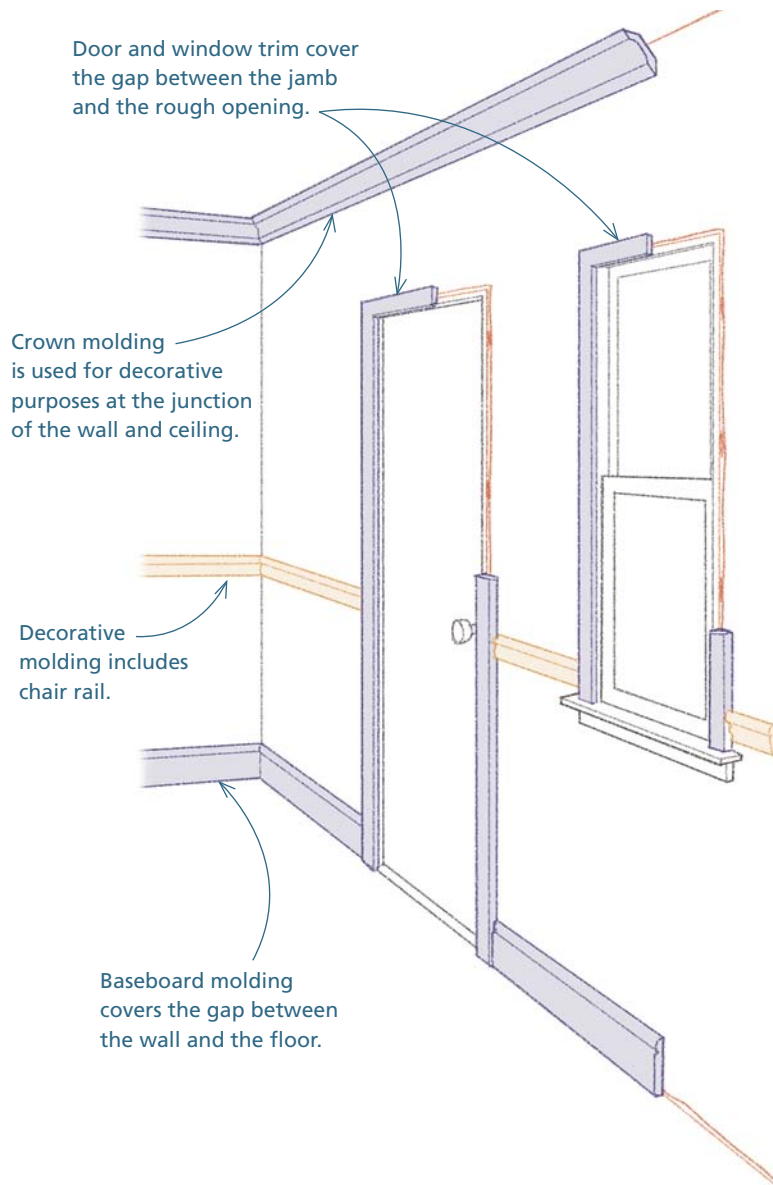

STEP 1 Check the jamb

The edge of the jamb should be flush with the surface of the drywall.

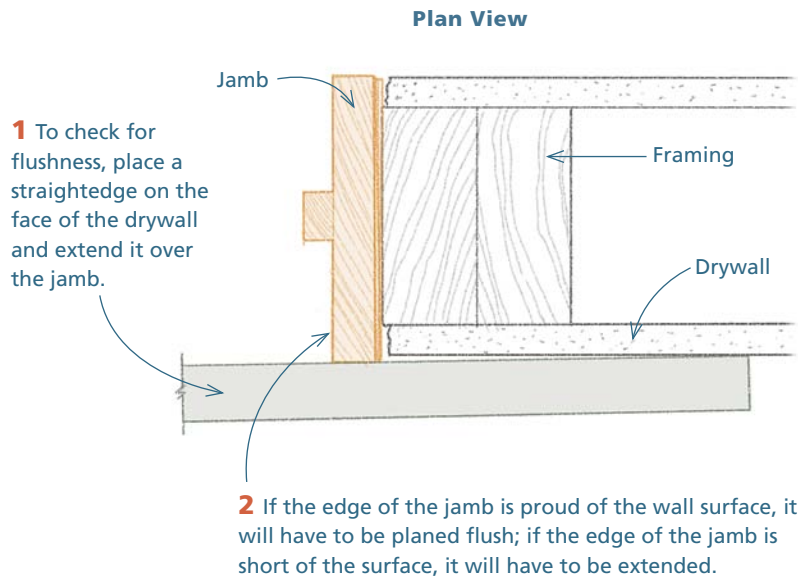

STEP 2 Plane the jamb if necessary

If you need to plane the jamb, use either a handplane or power plane.

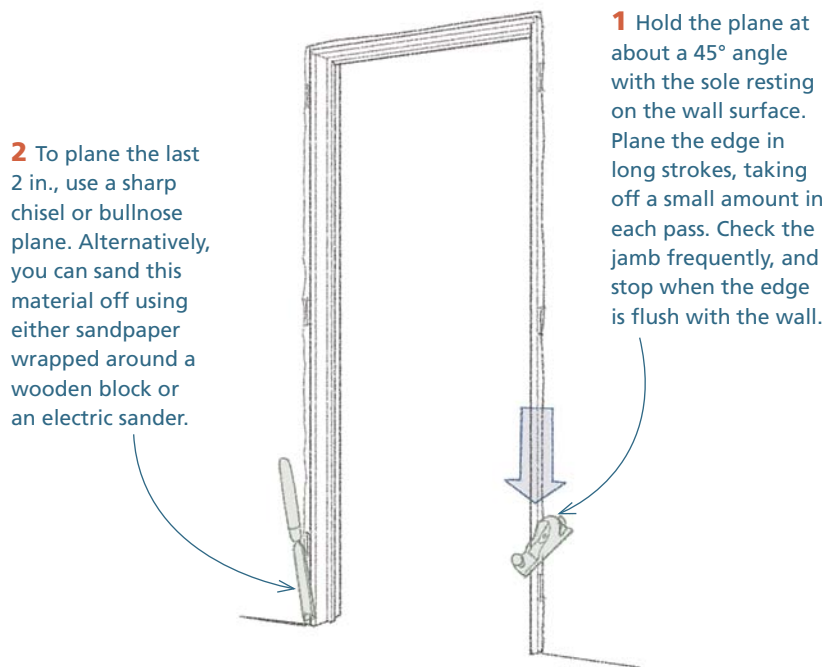

STEP 3 Extend the jamb if necessary



1 If the jamb is short of the wall surface, the jamb will have to be extended. Door and window manufacturers offer “jamb extensions” for use when the exterior walls (with ½-in. drywall) are thicker than 4½ in. If you don’t have these, rip a strip of ¾-in.-thick wood and tack it on the edge of the jamb.

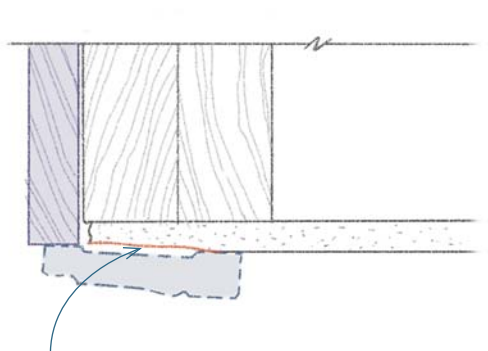

2 When the jamb is slightly recessed from the drywall (⅛ in. or less), you can often fix the problem by shaving the drywall surface with a drywall rasp. Make sure you don’t shave outside the area that will be covered by the casing.

STEP 4 Mark the reveal

The inside edge of the casing should be set in slightly from the face of the jamb. To maintain a straight and consistent reveal, set a combination square to the desired distance (typically ¼ in.) and use it to mark the edge of the jamb every 8 in. or so.

When marking the reveal at the top corners of the jamb, extend the lines past one another. That will make it easier to transfer the layout to the casing when you cut it to length.

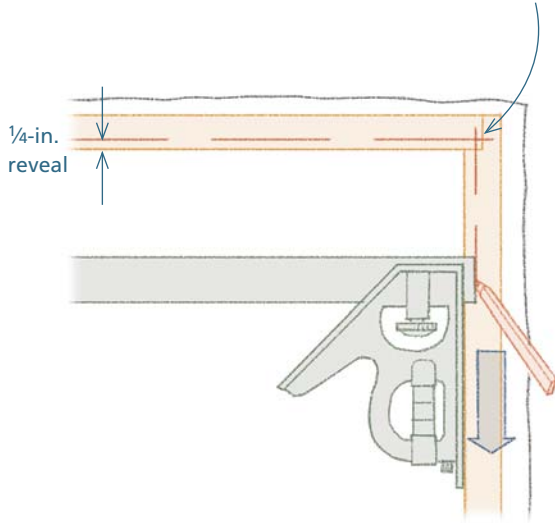

Miter Saw Options

The miter saw is the primary cutting tool for trim carpenters. There are three basic types, and manufacturers also offer a number of accessories and gadgets. Here's an overview of what's available.

Basic miter saws

This kind of miter saw, which has been in use since the 1970s, has a motor and blade assembly that's fixed in the vertical position. By swiveling the motor and blade assembly, you can cut any angle from 0° to about 50° (the exact range of angles differs slightly with different models). While basic miter saws ruled the trim-carpentry trade for two decades, they are uncommon today.

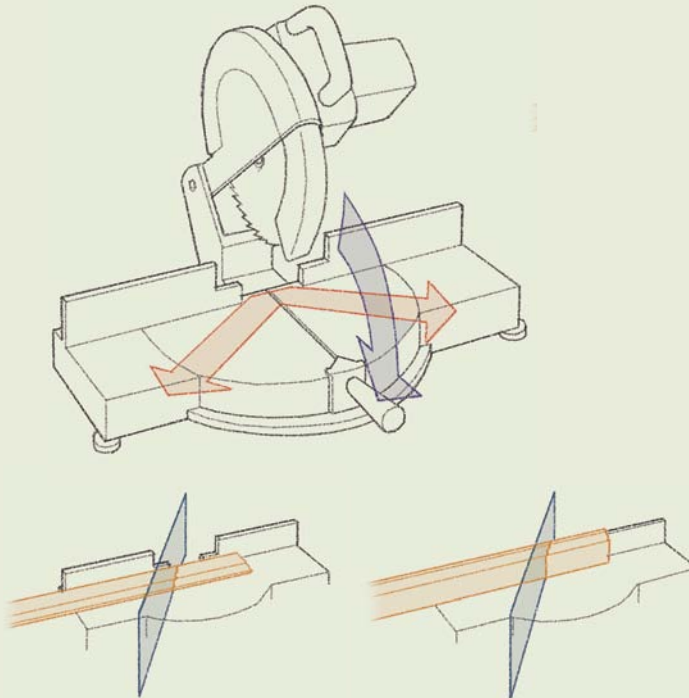

1 With a basic miter saw, if you hold the board or piece of trim flat on the table, the saw cuts a miter.

2 If you hold the board on edge against the fence, the saw cuts a bevel.

Compound miter saws

In the 1990s, manufacturers began offering compound miter saws in which the motor and blade assembly could tilt as well as swivel. This tilting feature is now standard, and miter saws that don't have it are as rare as cars that don't have automatic transmissions.

The tilting feature makes it possible to bevel the piece when it's flat on the table, significantly increasing capacity. A basic 10-in. miter saw, for example, can only bevel material up to 4 in. wide. By placing the piece flat on the table, a 10-in. compound miter saw can bevel stock almost 6 in. wide. A 12-in. compound miter saw bevels trim close to 8 in. wide. This added capability is a must for beveling the outside corners of tall baseboards. The tilting mechanism also increases the width of crown molding that can be cut at the required compound angle.

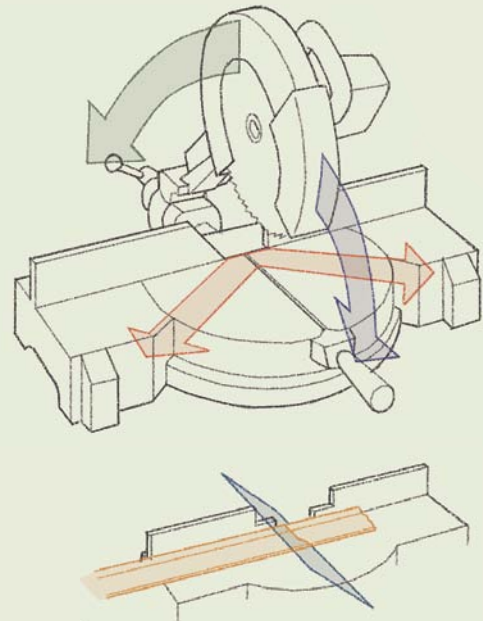

Compound miter saws have blades that tilt as well as swivel.

Sliding compound miter saws

Costing about twice as much as a compound miter saw, the sliding compound miter saw (SCMS) has a much larger cutting capacity. On these saws, the motor and blade assembly is mounted on an arm. By sliding the assembly along the arm, it's possible to make very long yet precise cuts.

Most SCMS are capable of crosscutting boards that are 12 in. wide. And they're capable of making compound miter/bevel cuts at 45°/45° in material that's 8 in. wide. Because of its long cutting capacity, the SCMS is also a great tool for making the compound miter cuts required for hip and valley roofs.

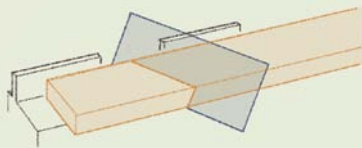
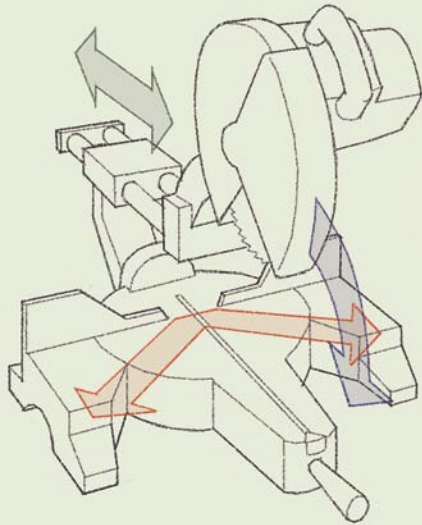

A 10-in. sliding compound miter saw can precisely cut just about any base or crown molding or crosscut shelves and stair-tread material.

Dual-bevel feature

By repositioning the motor and handle of their saws, some manufacturers now offer compound miter saws and SCMS that can be tilted to the right or the left.

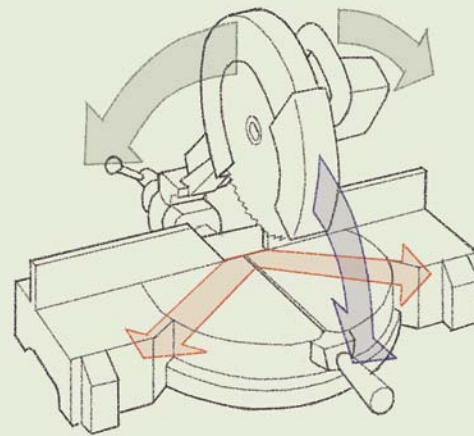

A dual-bevel feature adds to the cost of the saw, but it's well worth the money if you expect to install a lot of crown molding or build complex roofs.

Other features and considerations

Manufacturers offer a number of other features and accessories. These include electric brakes, digital angle readouts, detents and highlighted marks for common settings, laser lines, dust-collection systems, work lights, a variety of fence configurations, clamping systems, and stops. Make sure you consider the weight of the saw and how much noise it makes. This information can be found in comparative tool reviews, tool catalogs, and on Web tool sites. You can also check the specifications provided online by individual tool manufacturers.

STEP 5 Cut and install the top piece

1 Make a 45° miter cut on a piece of casing, then cut the piece off a few inches longer than will be needed.

2 Hold the piece in place with the bottom of the miter cut even with the intersecting lines that mark the reveal.

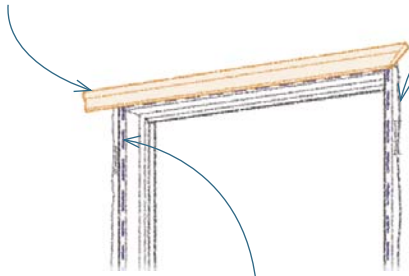

3 Mark the other end of the casing where the lines marking the reveal on that side intersect. Make a 45° miter cut at the mark. Then hold the piece on the reveal marks, and nail it in place.

STEP 6 Cut and fit the side pieces

1 Set a piece of casing on the floor with the finished (molded) face toward the wall and the outside edge butted to the top piece of casing.

2 Scribe along the top of the top piece of casing to mark the side piece to length.

3 Cut a 45° miter, with the long point of the cut at the mark.

4 Check the fit. If the joint is slightly open at the long point, recut the piece at a slightly increased angle (at 45½° or 46°). If the joint is slightly open at the short point, recut at a slightly decreased angle (44½° or 44°). Repeat the process until the joint fits tightly.

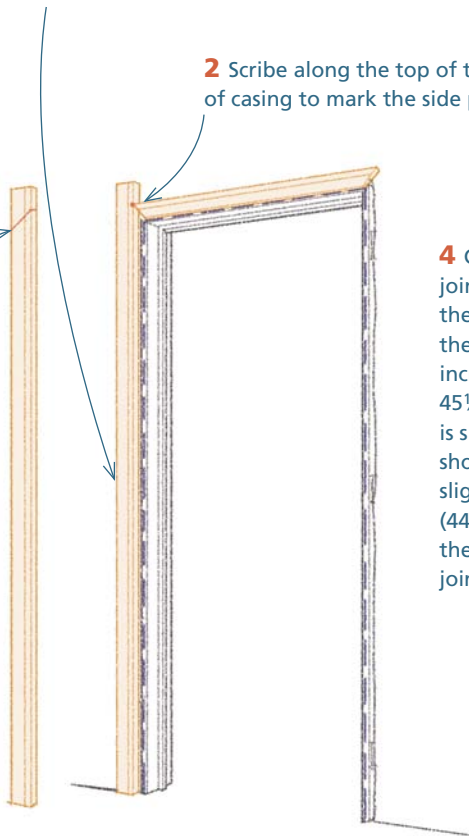

STEP 7 Cut the bottoms, if necessary

Flooring contractors typically have undercutting saws and can cut the bottom of the casing in place. Leaving this cut to the flooring contractor ensures that the casing will be cut at the correct distance above the floor. If you're going to install the floor yourself and you don't have an undercutting saw, however, you might want to cut the bottoms of the side pieces before you install them.

1 Hold the casing in place with the joint carefully fitted. (You may have to use a couple of nails to hold it in place temporarily.)

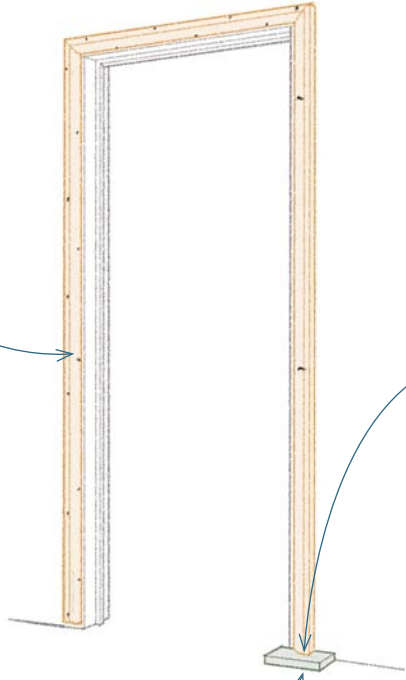

3 Place the mock-up next to the casing, and scribe the casing along the top of the mock-up.

Remove the piece and square-cut along the scribed line with your miter saw.

2 Make a small mock-up of the finished floor out of scraps. Be sure to include any underlayment that you plan on using.

STEP 8 Install the side pieces

On each side, hold the piece along the reveal marks with the joint lined up and nail it in place.

Joints for Trim Carpentry

The essence of trim carpentry is the ability to create neat, tight joints where pieces of trim intersect. There are five basic joints in trim carpentry.

Butt joint

This joint is commonly used to fit molding against the outside of door or window casing or other flat surfaces, such as the side of a cabinet. It's also used to fit the first piece of a coped joint into an inside corner.

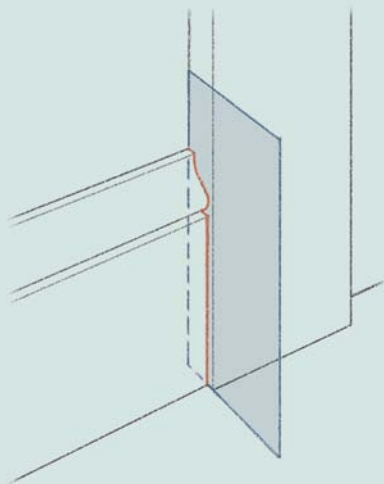

A butt joint is created by making a simple square crosscut in the trim. In some cases, the cut is adjusted a degree or two for a better fit.

Miter joint

Miters join two pieces that turn a corner. The pieces are cut at an angle that equals half the turn (45° each for a 90° corner). When the trim turns at an angle other than 90° , the miter is adjusted accordingly.

Because most of the trim in a house turns at a 90° angle, most miter cuts are close to a 45° angle.

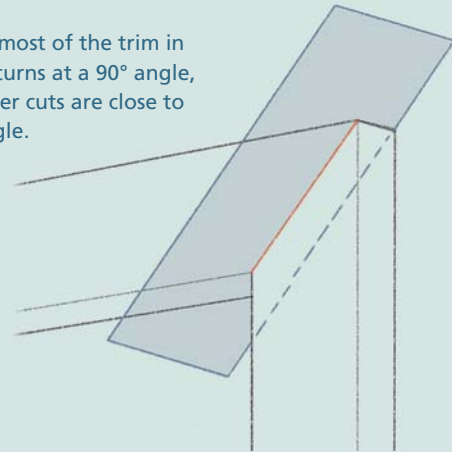

Compound miter joint

This joint is used mainly for crown molding. Crown molding is usually installed at a 38° angle to the wall. To accommodate this angle and go around the corners of the room at the same time, crown molding has to be cut at a compound angle.

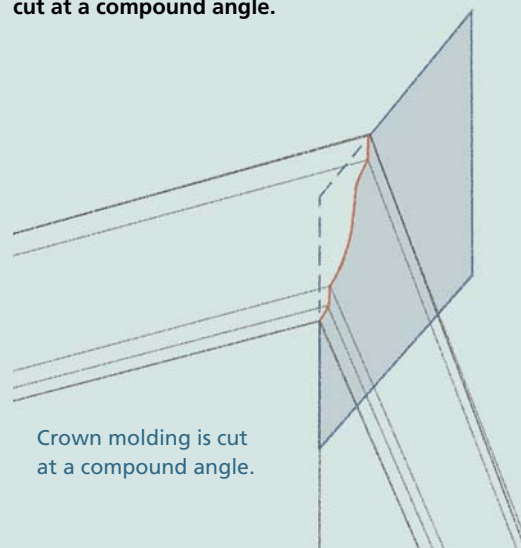

Crown molding is cut at a compound angle.

Coped joint

This joint is used to join certain moldings (baseboard, chair rail, and crown molding) at inside corners. The joint is made in two parts. If the butted end of the piece ends up $\frac{1}{16}$ in. short of the corner, it's not a problem because the gap at the butted end will be covered by the coped piece.

1 The end of the molding fits against the second wall with a plain butt joint.

2 On the second wall, the piece is "coped," or cut in the exact profile of the molding so it fits over the first piece.

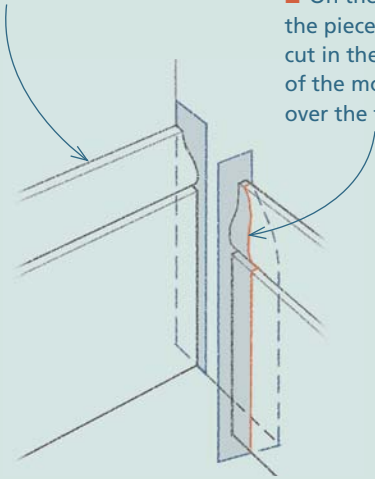

Splice joint

Sometimes called a scarfed joint, this joint is used to join pieces end-to-end. The joint should be placed over a solid nailing surface and should be used only when the wall of a room is longer than the longest piece of molding available.

In a splice, both pieces are bevel-cut at the same angle (usually a 30° or 45° angle).

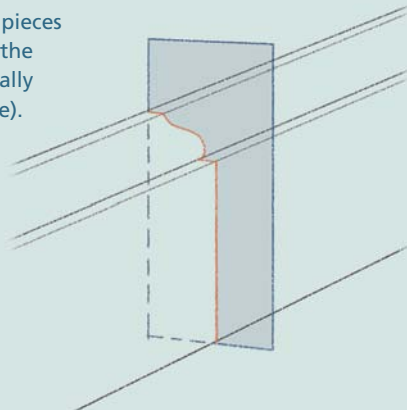

TOP TIP

Miter or Bevel?

Strictly speaking, a miter cut is an angled cut across the face of a piece of molding, and a bevel cut is an angled cut across the thickness of the piece. Carpenters don't always speak strictly, however, and in trim carpentry all joints formed by angled cuts are called "mitered joints."

WAYS OF WORKING

Nailing Schedule for Trim

- Casing, outside edge: One 2-in. finish nail (6d hand nail; 16 gauge x 2-in. gun nail) every 24 in. about $\frac{3}{4}$ in. from the edge.
- Casing, inside edge: One $1\frac{1}{4}$ -in. nail (3d hand nail; 18 gauge x $1\frac{1}{4}$ -in. nail gun brads) every 24 in. about $\frac{3}{8}$ in. from the edge.
- $3\frac{5}{8}$ -in. base molding: Two 2-in. finish nails (6d hand nail; 16 gauge x 2-in. gun nail) every 32 in. about 1 in. from the top and bottom edges.
- 3-in. chair rail molding, top edge: One 2-in. finish nail (6d hand nail; 16 gauge x 2-in. gun nail) every 32 in. through thickest portion of molding.
- 3-in. chair rail molding, bottom edge: One $1\frac{1}{2}$ -in. finish nail (4d hand nail; 16 gauge x $1\frac{1}{2}$ -in. gun nail) every 32 in. near edge of molding.
- 3-in. crown molding: One $2\frac{1}{2}$ -in. finish nail every 32 in. (8d hand nail; 16 gauge x $2\frac{1}{2}$ -in. gun nail). Nail in center of the molding; drive nail perpendicular to the face of the molding.
- $3\frac{1}{2}$ -in. and larger crown molding: Two 2-in. finish nails (6d hand nail; 16 gauge x 2-in. gun nail) every 32 in. about 1 in. from top and bottom edges.

Installing Window Trim

The following steps describe the installation of a traditional window trim treatment. This design includes a sill and an apron under the sill.

STEP 1 Check the jamb and adjust if necessary

Use the methods described in steps 1 through 3 in “Installing Door Casing” on pp. 398–399 to check the jamb. Plane or extend the jamb if necessary.

STEP 2 Mark the reveal

Use the method described in step 4 in “Installing Door Casing” on p. 399 to mark the reveal.

STEP 3 Mark the outside edge of the casing

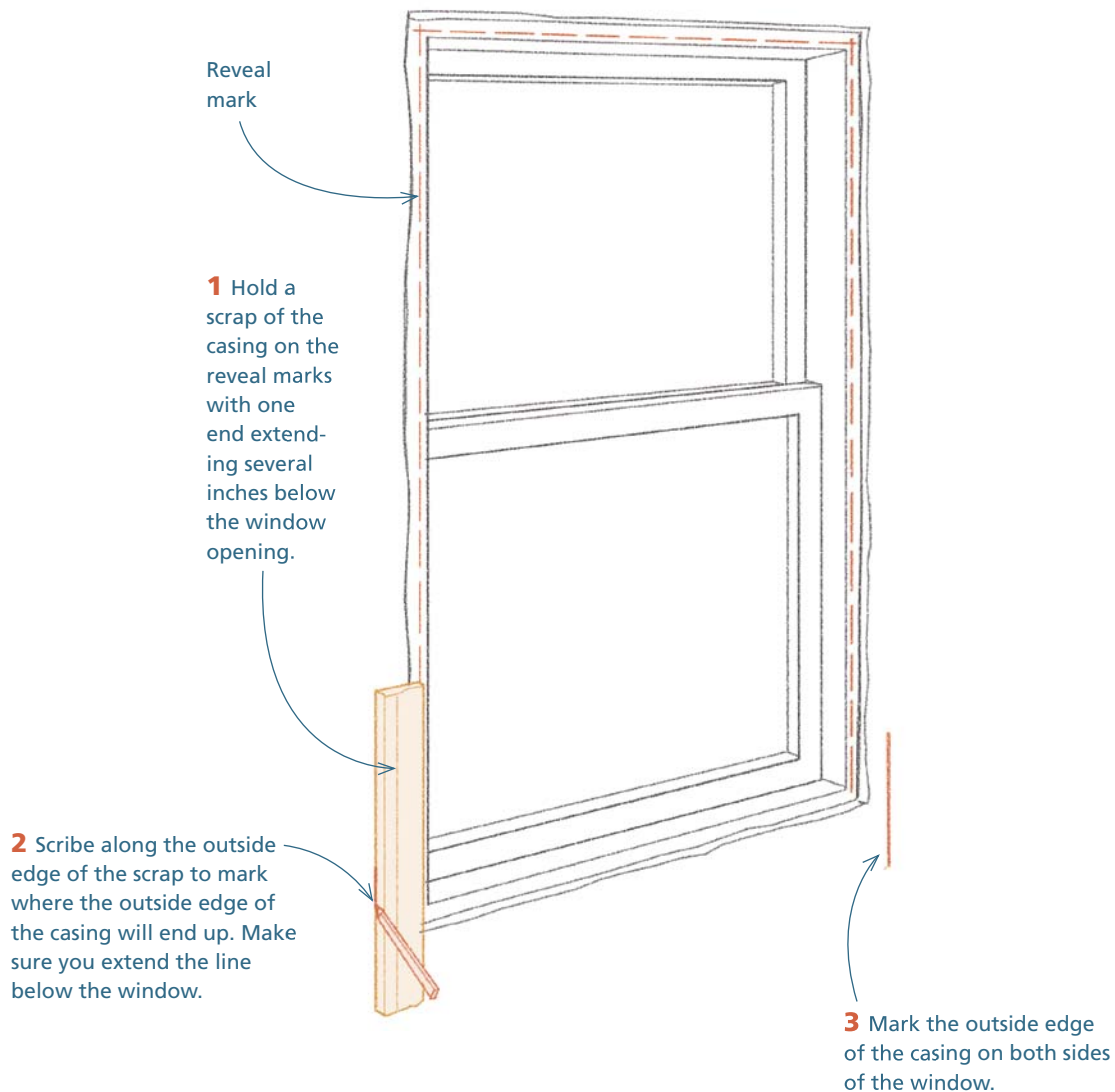

STEP 4 Cut and fit the windowsill

-
- 1** Measure and mark $\frac{3}{4}$ in. outside of the lines representing the outside of the casing.
- 2** Square-cut a piece of the windowsill material, and hold it against the wall with the cut end on one of the marks.
- 3** Transfer the mark at the other end to the windowsill, and cut the windowsill to length at the second mark.
- 4** Hold the windowsill on the marks, and mark it at the inside faces of the two jambs.
- 5** Set a divider to the distance between the sash and the edge of the windowsill.
- 6** At each end, run the divider along the wall. While one leg follows the wall, a pencil mounted on the other leg marks the windowsill the correct distance away.
- 7** Remove the windowsill, and use a square to extend lines from the marks you made at the insides of the jamb.
- 8** Use a jigsaw to cut out the rectangular pieces at each end of the windowsill.
- 9** Check the fit. Make sure the sash can close inside the sill.

STEP 5 Cut and attach returns on the windowsill

To carry the profile on the nose of the windowsill back to the wall, cut and install a return.

2 Cut matching 45° miter returns out of the windowsill material. (See "Cutting Miter Returns Safely," below.)

1 Cut 45° miters at both ends of the windowsill, with the long points at the outside corners of the sill.

3 Attach the returns. To avoid the possibility of splitting the return, don't use nails or brads. Use carpenter's glue, and clamp or tape the pieces together for a couple of hours. If you don't want to wait, use a fast-acting glue.

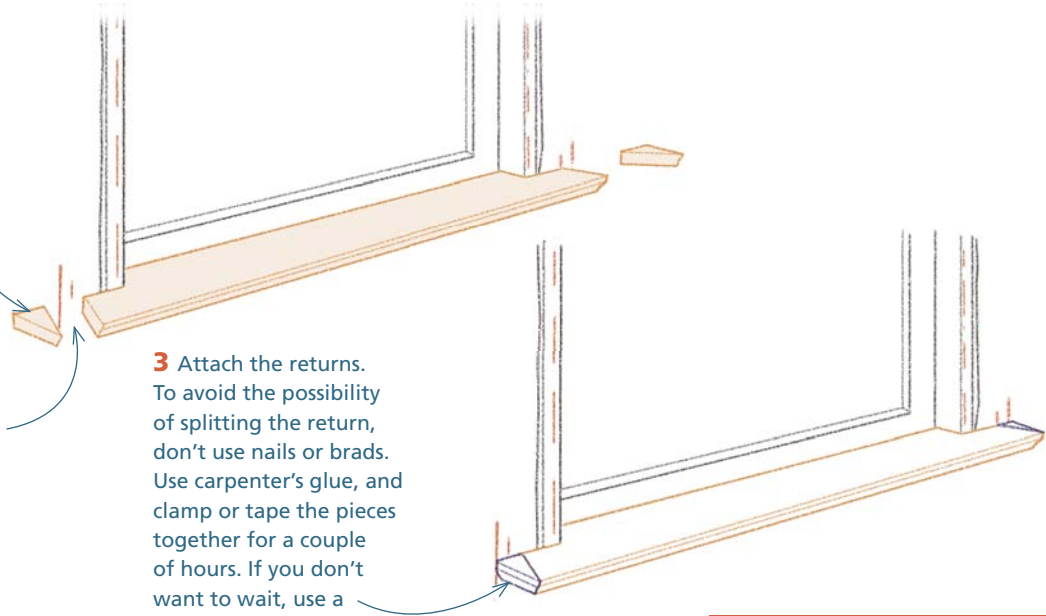

SAFETY FIRST

Cutting Miter Returns Safely

When you need to cut a miter return, start by making the miter cut at the end of a piece at least 8 in. long. Then cut the tiny return off with your hand a safe distance away. If you cut the miter return a bit too long, don't be tempted to recut it; start over with a larger piece.

STEP 6 Install the windowsill

Line up the ends of the windowsill with the marks on the wall, and install it with 2-in. finish nails.

STEP 7 Cut and install the side pieces of casing

1 Square-cut two pieces of casing a few inches longer than you'll need.

3 Mark the top at the reveal mark at the top of the window. Repeat the process on the other side of the window.

4 On each piece, cut a 45° miter, with the short end of the cut even with the mark.

2 Set one of these pieces on the windowsill with the inside edge even with the reveal marks.

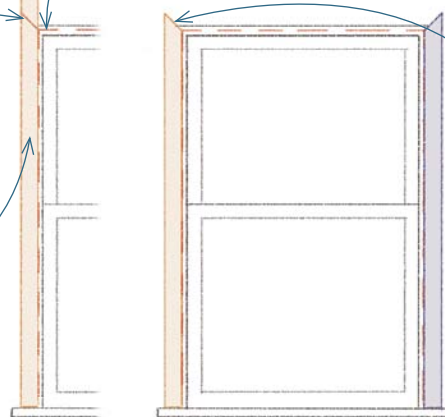

5 Install the pieces with the bottom sitting on the windowsill, the inside edge even with the reveal marks, and the bottom of the miter cut even with the reveal mark at the top.

STEP 8 Install the top piece of casing

Make 45° miter cuts at both ends of a piece of scrap. Hold the test piece on the reveal marks, and test the fit at both ends. On each side, adjust the miter setting, if necessary, until you get a satisfactory fit. Note the setting when you get a good fit.

- 3 Cut the top piece at the marks. For each end, adjust the miter saw to the setting you noted when you pretested with the scrap. Make the long point of the cuts even with the marks. Nail the piece in place.

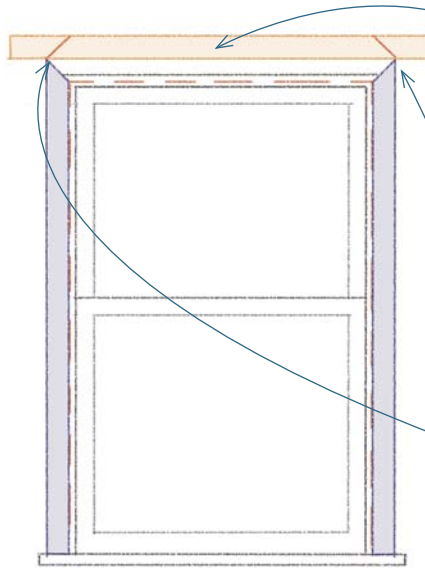

- 1 Cut a piece a few inches longer than you'll need. Set the piece upside down and bridging across the top of the two side pieces.

- 2 Mark both ends of the top piece by scribing along the outside edges of the side pieces.

STEP 9 Cut and install the apron

- 1 Cut a piece of apron that's a few inches longer than the sill.

- 3 Mark the top of the apron at the vertical lines you drew (in step 3), laying out the locations of the outside edges of the two side pieces of casing.

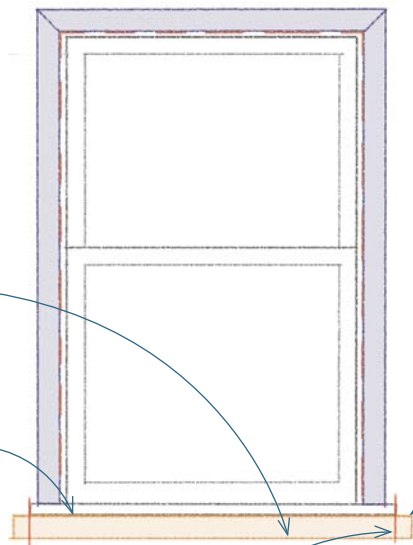

- 4 Use a square to transfer the marks from the back of the top edge to the front. Extend the marks around the corner to the front face of the apron.

- 6 Cut and glue miter returns on each end of the apron. Begin by cutting bevels in a scrap of apron, with the long points of the cuts along the finished face of the molding. Crosscut the piece at the short points of the bevel to create the returns. To attach the return, use carpenter's glue and tape it in place. Set the piece aside for a couple of hours. If you don't want to wait, you can use a fast-acting adhesive.

- 2 Place the piece upside down on the wall with the bottom butted tight to the underside of the sill.

- 5 Cut a 45° bevel at each of the marks with the long point of the cuts at the marks on the front of the casing.

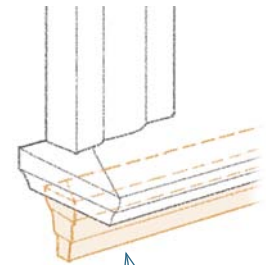

- 7 Hold the apron assembly against the bottom of the sill and centered between the vertical lines. Nail it in place.

Installing Baseboard Molding

There are two basic kinds of baseboard molding. The first is a traditional two-piece system made up of a baseboard and a base cap molding. In the past, the baseboard was usually made from 1x6 or 1x8 boards; today, baseboard that will be painted is often made of medium-density fiberboard (MDF). Base cap molding, which is milled in a wide variety of profiles, is installed on the top edge of the baseboard after the baseboard is installed.

The second kind of baseboard molding is made in a single piece. In the most common profile, the molding is 3½ in. to 4 in. wide. The top inch or so has an ogee shape and the lower 3 in. or so has a flat face. It's made to resemble two-piece molding, but it's a lot smaller than its predecessor.

Traditional two-piece baseboard molding takes longer to install than one-piece base molding because, with two-piece molding, you have to install twice as many pieces. The joinery in two-piece molding, however, is simpler because it's divided into two manageable parts.

This section discusses the installation of the more common one-piece molding. Although two-piece molding is more attractive and more expensive, one-piece molding is more challenging to install. If you can install one-piece base molding, you should have no problems installing two-piece base molding.

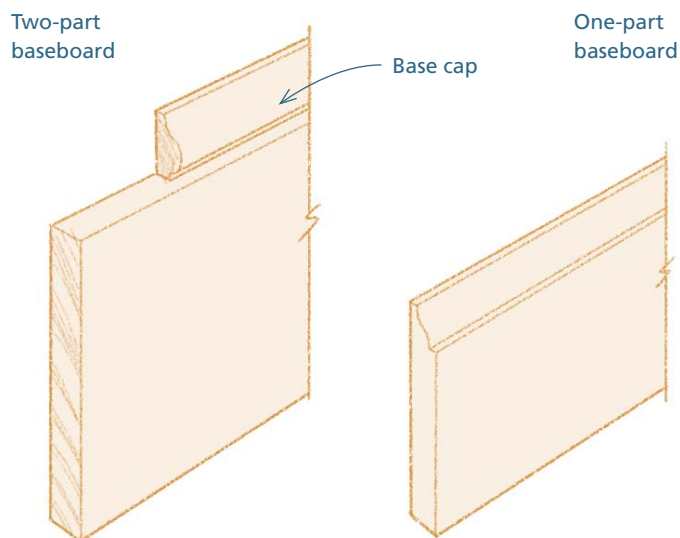

Planning and Preparing for Baseboard

Baseboard molding fits against the outside edges of door casing, base cabinets, built-in bookcases, and other flat surfaces. These items, therefore, must be installed before you can run the baseboard. Furthermore, before you start the baseboard molding in any room, it pays to spend a little time preparing the surface of the wall that will receive the base molding. Doing so can make the installation go smoother and improve the quality of the job. It's also important to allow for the floor covering, which usually does not get installed until the rest of the finish carpentry is completed.

Preparing the walls Take a quick look at the base of the walls, especially at the inside and outside corners. These are the points where pieces of the baseboard molding will have to be joined. Look for globs of drywall compound that might keep the molding from lying flat against the wall. If you see any clumps, scrape or sand them off.

Another potential problem is that the walls usually taper in at the bottom. In most houses, two full, horizontal panels of drywall cover the walls. Because the panels are manufactured with tapered edges, the edge along the floor—just where you need to attach the base molding—usually swerves inward about $\frac{1}{8}$ in. in the last few inches. When you nail the molding to this surface, the bottom gets pulled in and ends up out of square with the floor. This complicates the joinery at the inside corners and often results in joints that are open at the bottom. To keep the baseboard from tilting in, use a screw or a shim at the bottom of the tapered edge, as shown in the drawing at right.

Matching the gap to the floor covering Make sure the gap below the baseboard (see the sidebar on p. 413) matches the floor covering that will be installed later. When the floor covering will be wood, tile, or vinyl (over a layer of underlayment), determine the total thickness and add about $\frac{1}{8}$ in. If $\frac{3}{4}$ -in. wood flooring is planned, for example, raise the baseboard molding about $\frac{7}{8}$ in. The gap will be covered by a piece of shoe molding, which is usually installed by the flooring contractor.

Use scraps to hold the baseboard molding up To hold the baseboard molding a consistent distance above the subfloor, set it on blocks as you install it. You can often find scraps of material that are the right thickness on site. If you want to raise the baseboard $\frac{1}{2}$ in., for example, you can cut some blocks out of $\frac{1}{2}$ -in. sheathing scraps. If you can't find material that matches the gap you want to create, rip blocks to the desired thickness on a tablesaw.

Set a square on the floor to check the surface. If the wall tapers in, use shims or drywall screws to create a plumb surface for the baseboard molding.

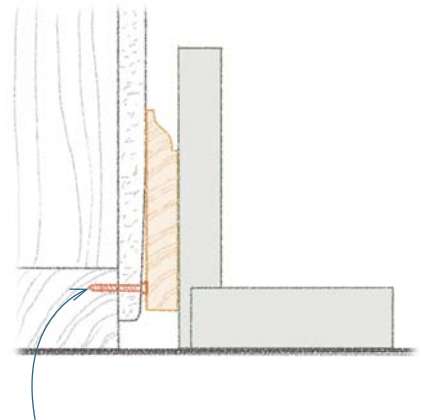

Drywall screws hold the baseboard plumb. Drive the screws in at the bottom of the wall, leaving the head about $\frac{1}{8}$ in. proud of the surface. Check the alignment of the screw head with the wall above by placing a square on the floor. If necessary, turn the screw in or out to fine-tune its position.

Six Rules of Trim Carpentry

Although there are many variations in molding profiles and trim applications, most installations follow these basic principles.

Rule 1: Work from large to small

To reduce the number of splice joints and to save material, start on the long walls. Use the cutoffs from the longer walls for closets, bump-outs, and other short walls.

Rule 2: Work from the inside out

Joining inside corners is usually the most challenging part of trim carpentry. Pieces rarely fit on the first try, and slight adjustments to the cut are routinely required. When the far end of the piece will end at a window or door casing or an outside corner, take advantage of the open end.

1 Leave the piece several inches long as you work on the joint at the inside corner.

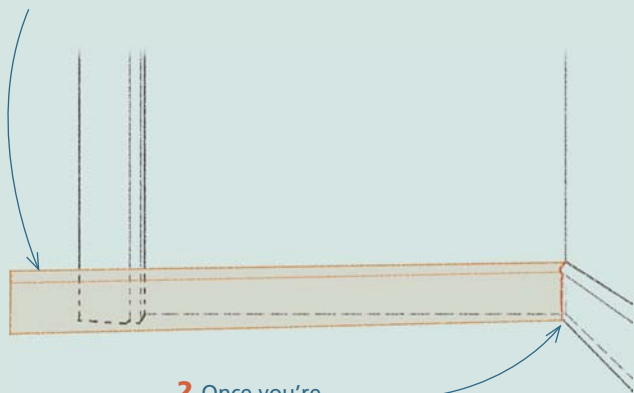

2 Once you're satisfied with the inside corner, mark and cut the piece to fit the open end.

Rule 3: Work from the complex to the simple

1 If you have to install a piece of base molding that extends from a stone chimney to a door casing, fit the irregular scribed cut at the chimney first.

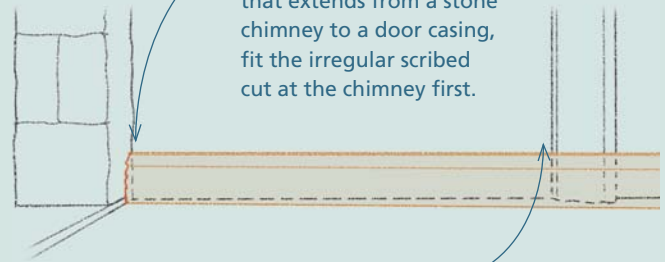

2 After you fine-tune this difficult joint, you can hold the piece in place and mark it at the door casing for the simple, straight cut required there.

Rule 4: Avoid coped cuts at both ends

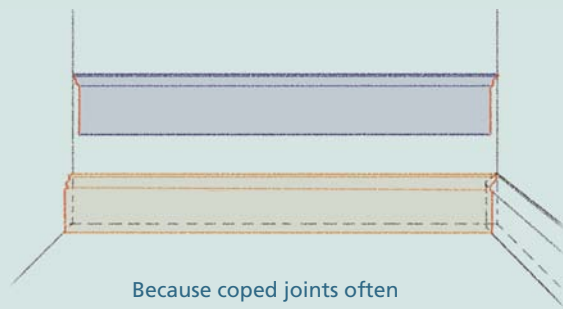

Because coped joints often require some fine-tuning, it's difficult to get tight coped joints at both ends. Plan ahead to avoid double-coped pieces.

Rule 5: Consider lines of sight

Coped joints are hard to see if you view the joint from behind the overlapping piece. To enhance the perceived quality of the joint, therefore, think about the most common lines of sight and lap coped joints parallel to those lines whenever possible.

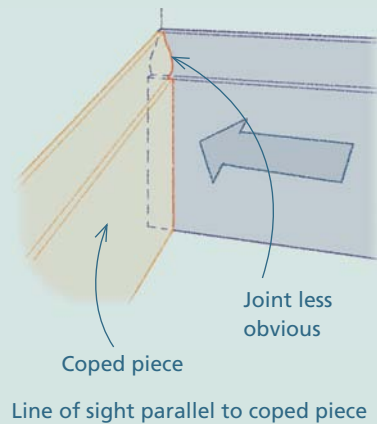
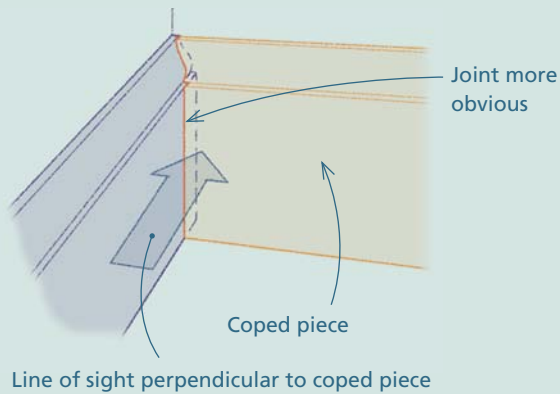

Rule 6: Measure as little as possible

Trim is light. It's usually easy to hold it in place as you mark it to length. Doing this is almost always faster and more accurate than taking a measurement and then transferring that measurement to the piece of trim.

TOP TIP

Raising the Baseboard off the Subfloor

For both practical and aesthetic reasons, it's usually a good idea to leave a gap between the bottom of the baseboard molding and the subfloor. On a practical level, this gap leaves room for finish-floor systems to expand. On an aesthetic level, raising the baseboard leaves more of it exposed to view after the finish floor is installed. This can make a big difference, visually, when you're using a small, one-piece base molding.

TOP TIP

Caution with Carpeted Floors

Be careful about raising the baseboard molding when the planned floor covering is carpet. It's difficult to attach shoe molding when the floor is covered in carpet. So, if you end up with a gap between the bottom of the baseboard molding and the carpet, the standard solution is of little help.

Carpet is a soft material that's stretched over hooks when it's installed. This means that, unlike most floor-covering materials, you don't have to provide room for it to expand.

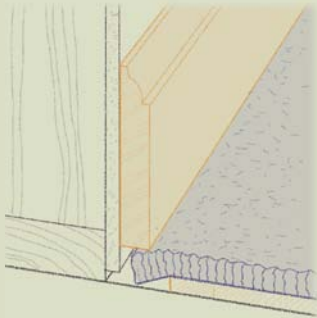

Make the gap under the molding fairly small (about $\frac{3}{8}$ in. for short-pile carpet and $\frac{1}{2}$ in. for tall-pile carpet). This leaves just enough room for the carpet installer to tuck the end of the carpet under the molding.

Cutting and Fitting Baseboard Molding

This section uses the example of a bedroom with a closet to show how to run baseboard molding in a typical room. The best place to start baseboard molding is often the wall opposite the main door. In this example, this starting point has two advantages: The coped pieces will all be aligned with the primary line of sight (the doorway), and no pieces will have two coped joints.

● INSTALLING BASEBOARD MOLDING

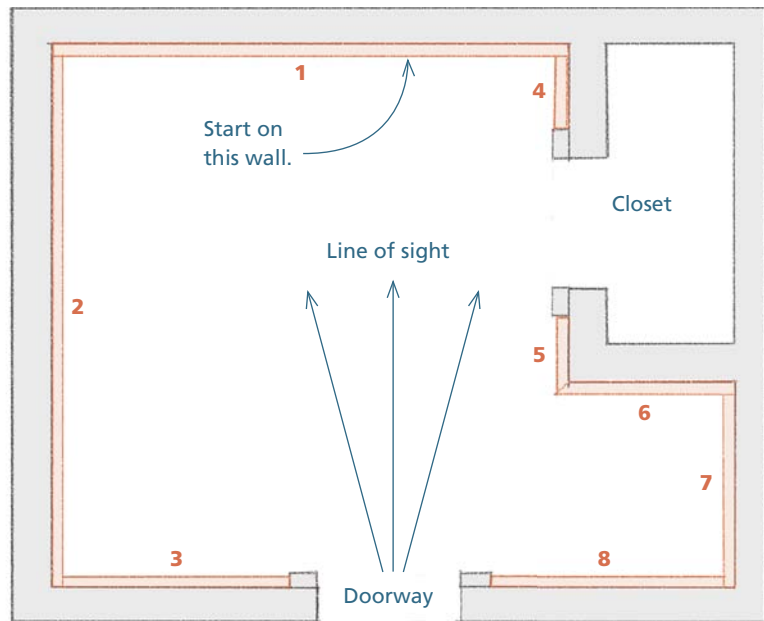

STEP 1 Install the first piece

1 Measure the wall from corner to corner.

2 Transfer the measurement to a piece of the molding, and cut both ends square.

3 Set the piece on blocks to hold it at the desired height, and nail it in place.

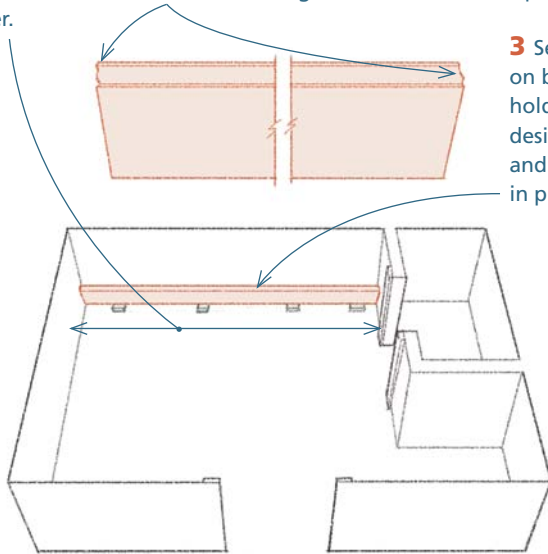

TOP TIP

Inside-to-Inside Measurements

.....
 Rather than bending a tape measure into an inside corner and guessing which mark on the tape coincides exactly with the corner, use a measured block. Begin by cutting a block exactly 10 in. long. Butt one end of the block into the corner, and mark along the other end. Measure from the opposite corner to the mark, and then add the 10 in. back to the measurement.

STEP 2 Install the second piece

4 Hook the end of your tape over the lower, straight section of the coped cut. Pull the tape from that point as you transfer the measurement from the wall, then square-cut the piece at the measurement.

3 Cope the end of a piece of the baseboard molding that's longer than the wall. (See "Coping Basics" on p. 419.)

2 Measure from the face of the first piece to the far corner.

1 Set blocks in place to raise the molding the desired amount.

5 Set the piece in place, and check the fit at the coped end. If the cope isn't satisfactory, mark where it needs to be cut. Remove the piece and fine-tune the cut. Install the piece.

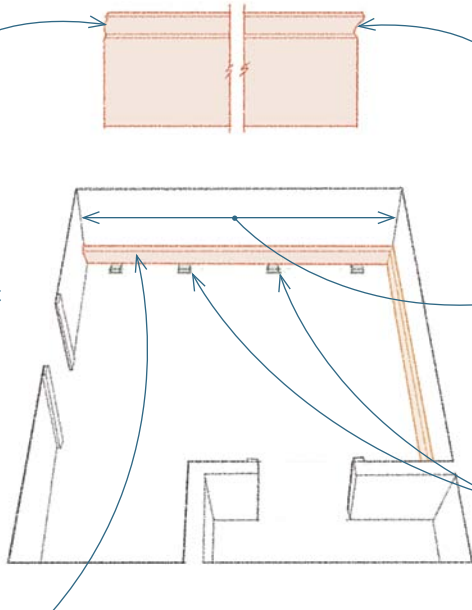

STEP 3 Install the third piece

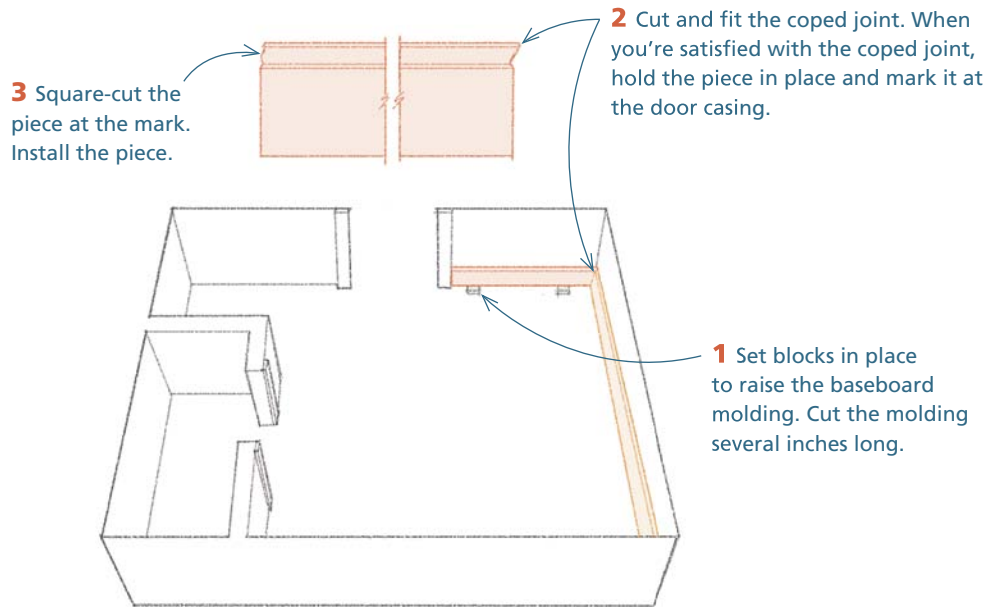

STEP 4 Install the fourth piece

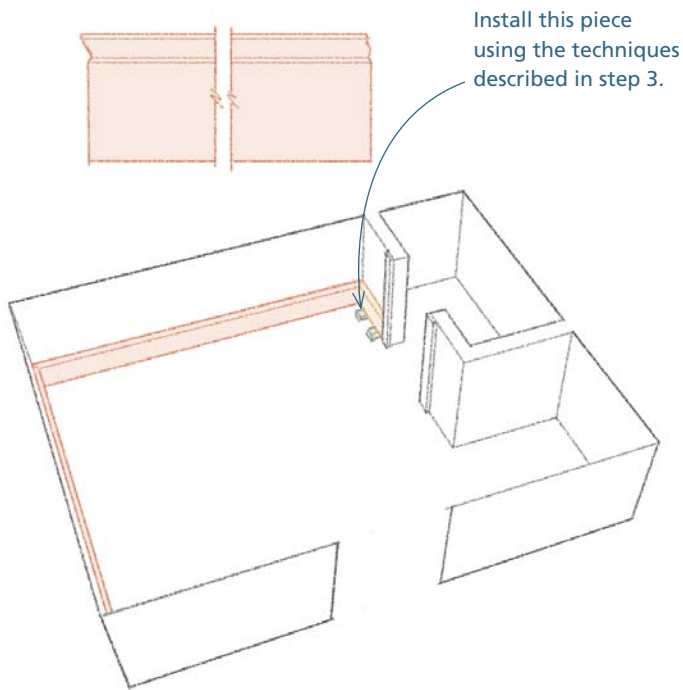

TOP TIP

Locating Studs

.....

If the walls have been painted and you're having a hard time finding the studs, check beside the electric outlets. Electricians nail the boxes for these outlets to studs. You can also use a stud finder or a rare-earth magnet to locate the studs. If all else fails, drive a finish nail or drill a small hole every inch in a horizontal line until you hit a stud. If you use a nail or a drill to find the studs, make sure you do so in a place that will be covered by trim. Once you find a stud center, measure in 16-in. or 24-in. increments away from that point to find the rest of the studs.

.....

STEP 5 Install the fifth and sixth pieces

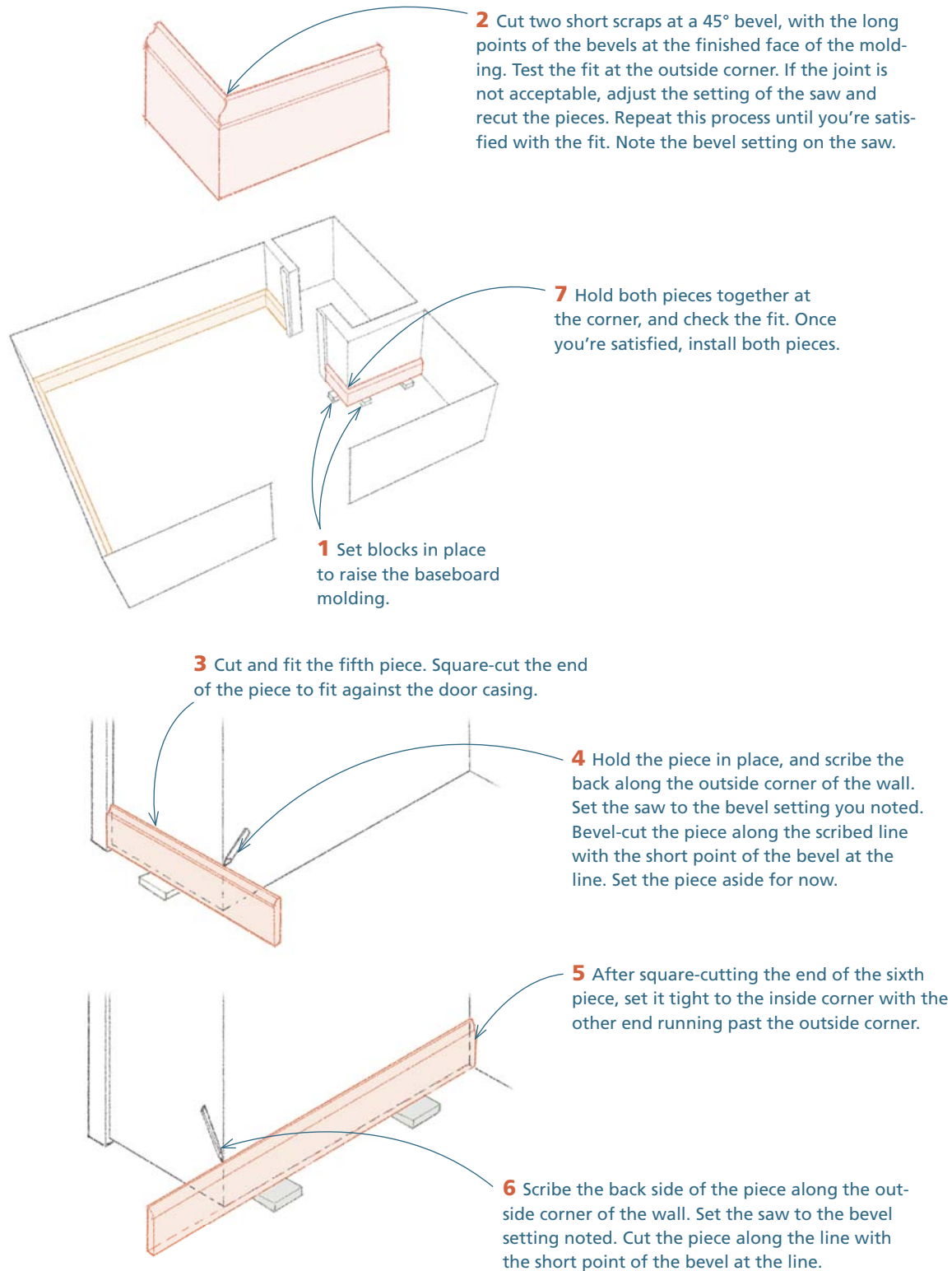

STEP 6 Install the seventh piece

Use the techniques described in step 2 to fit and install the seventh piece.

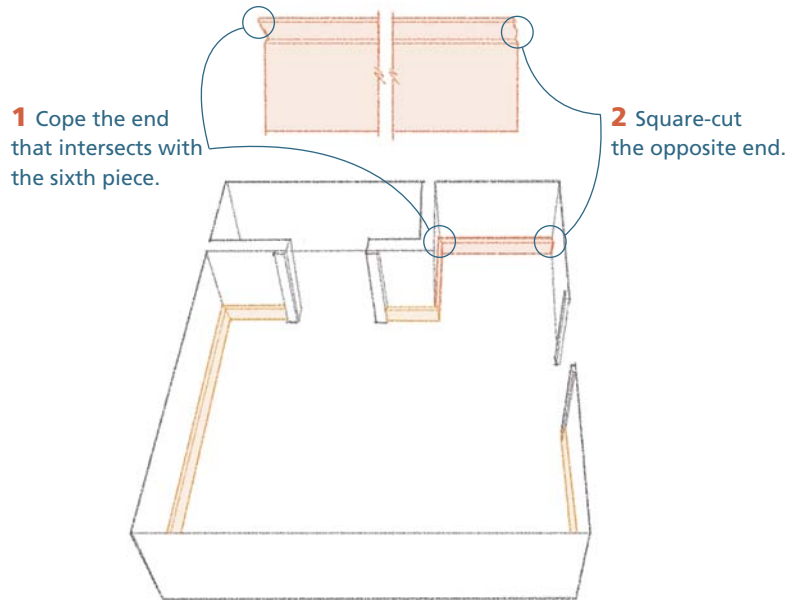

STEP 7 Install the eighth piece

Use the techniques described in step 3 to fit and install this piece.

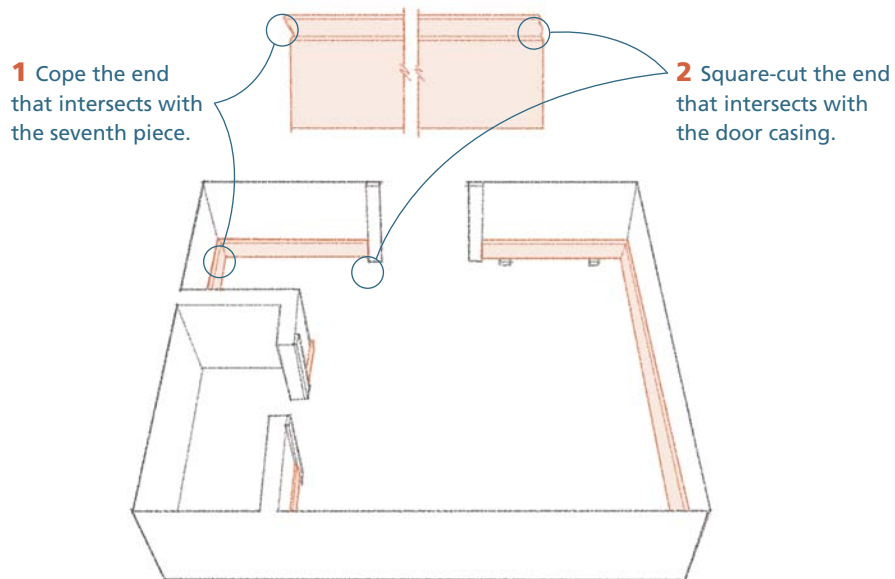

ESSENTIAL SKILLS

Coping Basics

Coping the end of a piece of molding to fit over the profile of an installed piece is a three-step process: Mark the profile, cut the profile, and, in most cases, fine-tune the cut.

To speed up the cuts, finish carpenters sometimes use power tools. The most common of these are jigsaws fitted with a special shoe, such as the Collins Coping Foot, or 4-in. grinders equipped with a coarse sanding disk.

Tools for fine-tuning the fit

Carpenters differ widely over the proper tools to use for removing the last bit of wood that keeps a joint from closing tight. Some like to pare away the offending projections with sharp-edge tools such as chisels, knives, and handplanes. These offer precise control but only if they're razor sharp. If you want to use edge tools, you have to develop sharpening skills.

Other carpenters prefer sandpaper and rasps. To follow straight sections of the profile, wrap sandpaper around wood blocks; to follow round sections of the profile, wrap the sandpaper around dowels and short sections of plastic pipes.

Another option is to use electric sanders and grinders. Some detail sanders offer great control, but they're expensive and they can be slow. Belt sanders and grinders are faster, but they can be too aggressive and quickly ruin the joint.

The choice of tools for fine-tuning the joint is a personal matter. Experiment with different approaches, and use the tools that work best for you.

MARKING THE PROFILE

1 Make a 45° bevel cut with the short point, or heel, of the bevel on the face of the molding. The irregular edge created along the heel of the bevel cut precisely mimics the profile of the molding.

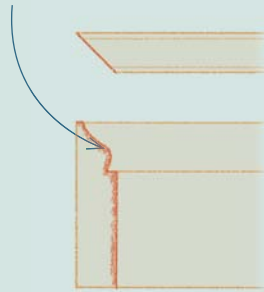

2 You can make this edge more visible by rubbing it with the side of a pencil lead.

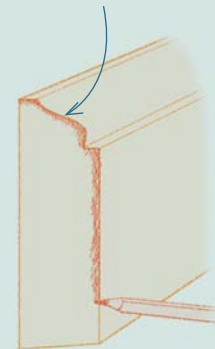

CUTTING THE COPE

Once you've marked the profile, clamp the piece to your worktable and use a coping saw to cut precisely along the line.

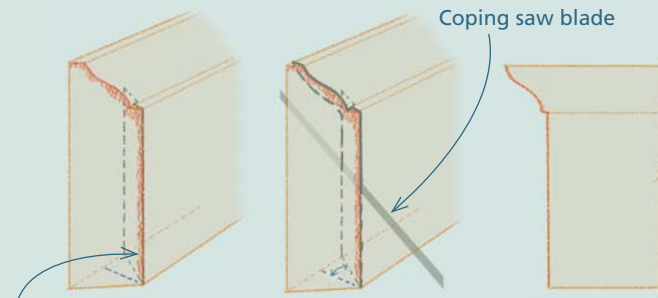

As you cut, tilt the coping saw at about a 30° angle in from the face. This is called back-cutting and is designed to remove material behind the leading edge of the joint that might keep the front of the joint from closing.

FINE-TUNING THE CUT

After cutting the cope, check the fit by holding the piece in place.



1 If there's a gap of equal size along the entire joint, there's material behind the front edge that's keeping the joint from closing. Remove the piece and pare or sand away material behind the leading edge of the joint.



2 If there's a tapered gap, you'll need to work on the front edge of the cut. Carefully mark a line that runs parallel to the profile of the piece you're joining. This line should be offset from the face of the piece you're joining at least as much as the width of the gap. Remove the piece and pare or sand to the line.

Installing Chair Rail Molding

Chair rail molding is typically installed along a level line 33 in. to 36 in. above the floor in the same basic manner as baseboard molding.

Laying Out the Job

Chair rail molding was originally designed to keep the backs of chairs from damaging plaster walls. For this reason, chair rail is usually installed with the top 33 in. off the finished floor, which is about the average height of the top of the back of a dining room chair.

Mark a level line around the room at that height. The best tool for this layout is an accurate laser level, especially one that projects a level line. If you don't have a laser level, you can use an optical builder's level or a reliable spirit level.

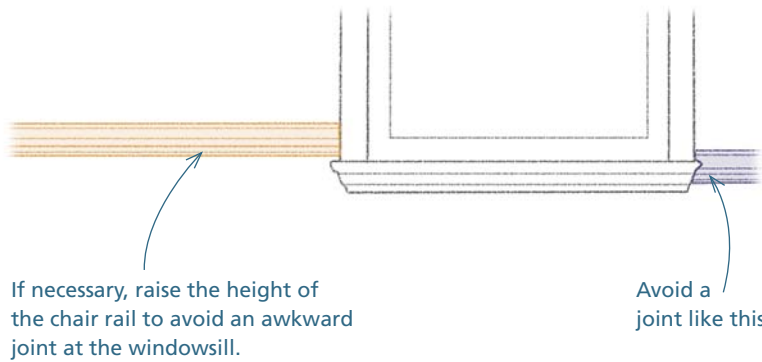

Getting the Right Side Up

There are many profiles for chair rail molding, so it can be confusing to decide which edge goes up. In most cases, the thickest part goes up.

Carpenters usually join chair rail molding at inside corners with coped joints. If the profile is very complex, however, it's often easier to miter inside joints. To get the joints tight, cut test pieces in scrap material until the joint is satisfactory.

As with other types of molding, plan the installation so that you can work from the inside out. When you have to fit a piece with an inside corner and an "open" end (an end that runs into a window or door casing or an outside corner), deal with the inside corner first and leave the other end long. After you get the inside corner right, mark and cut the open end. Also, keep the primary line of sight in mind when you plan the order of installation.

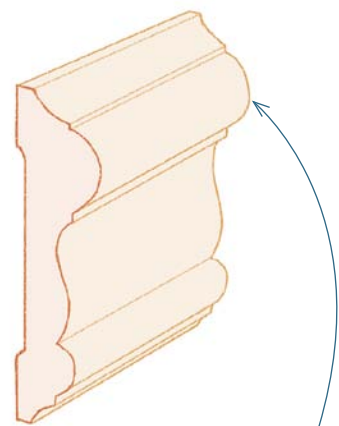

The thickest part of the molding is usually rounded and might be called the "rail" of the molding. In most cases, this thickest part goes up.

Installing Crown Molding

Installing crown molding is one of the most challenging jobs in trim carpentry. The main difficulty is that most types of crown molding have to be installed at an angle to the wall. This means that the cuts for inside and outside corners must be compound miter cuts. Adding to this difficulty is the fact that almost all of the joints for crown molding are inside corners. While the simple butt joints at doors and windows provide relief when you're running baseboard or chair rail molding, crown molding usually runs above those openings.

Order of Installation

In a simple rectangular room, the walls meet at four inside corners. All the joints in the crown molding, therefore, will be inside corners. In these rooms, you have two options.

● OPTION 1: COPE BOTH ENDS OF THE FINAL PIECE

This option is difficult because both coped joints have to be accurately cut on the first try. If one of the copes is open, you can't fine-tune the joint without shortening the piece and thus creating a gap at the other end.

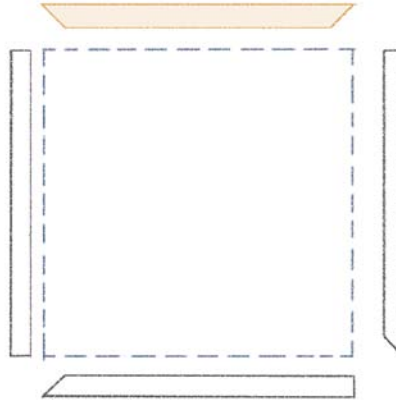

● OPTION 2: ALL FOUR PIECES HAVE ONE COPED JOINT

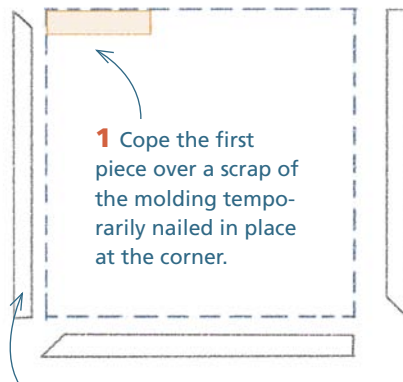

2 After fine-tuning the coped end, square-cut the opposite end and install the first piece.

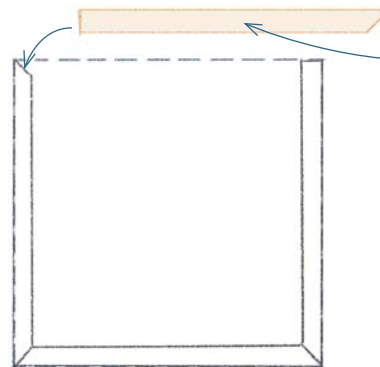

3 After installing the next two pieces, remove the scrap and slip the square-cut end of the last piece inside the coped end of the first piece. This second option is more forgiving because the last piece can be slightly short.

Both of the options mentioned on p. 421 are difficult to do well. So, if the room you're working in happens to have an outside corner, take advantage of it. By working toward the outside corner, you can leave the final two pieces long as you fine-tune the coped inside corners.

• WORK TOWARD THE OUTSIDE CORNER

1 Fit the two inside corners tightly.

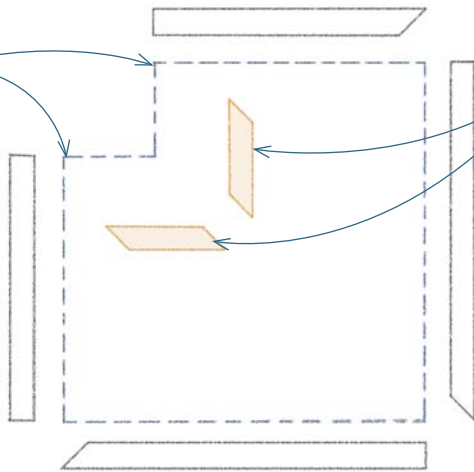

2 Cut the pieces for the outside corner. To avoid an open joint at the outside corner, cut test pieces with scrap material to establish the exact miter setting you need. (For more on fitting the pieces at outside corners, see "Cutting and Fitting Baseboard Molding" on p. 414.)

Cutting Compound Miters

Most crown molding is designed to fit in the wall/ceiling intersection at a 38° angle from the wall. A few styles of crown, mainly cove-shaped moldings, are designed to fit at a 45° angle. In the parlance of carpentry, this angle is called the "spring angle." Whether the spring angle is 38° or 45°, there are two ways to cut the compound miters required for the joints.

• METHOD 1: NESTING THE CROWN

The tilted crown combined with the miter setting creates the compound cut.

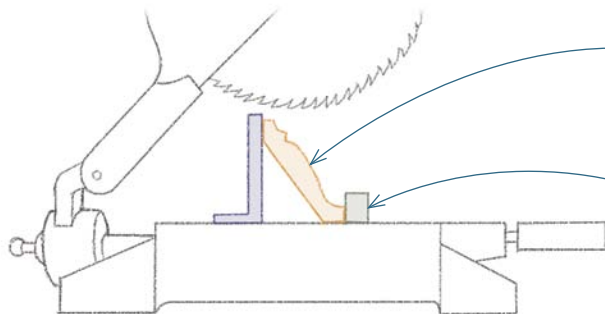

1 Prop the crown against the fence at the correct spring angle. Set the miter angle to make the cut. If the walls turn at a true 90° angle, set the saw to a 45° miter.

2 The nesting method requires a jig or, at a minimum, a line on the table of the saw to ensure that the piece is leaned against the fence at the correct angle. Once this preliminary setup is complete, nesting the crown simplifies the compound cuts.

• METHOD 2: LAYING THE CROWN FLAT

2 With the piece lying flat on the table, set the miter by swiveling the motor and blade assembly.

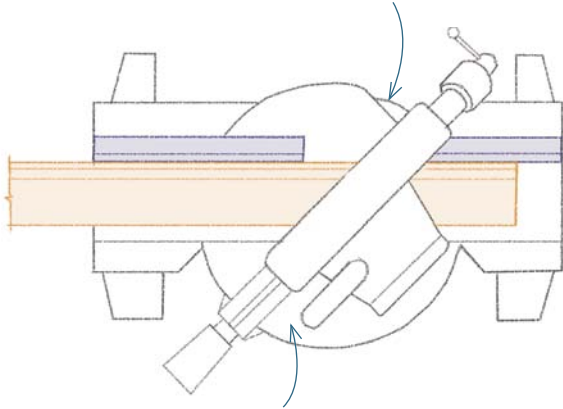

3 The scale for this setting is the large semicircular scale below the table and at the front of the saw.

4 The bevel is set by tilting the motor and blade assembly. The scale for this setting is above the table and toward the back of the saw.

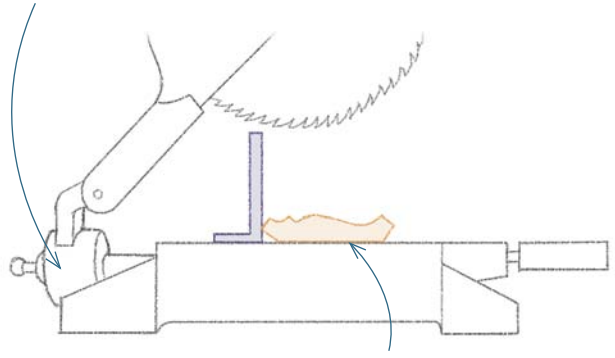

1 Place the molding flat on the saw with the molded face up. Depending on the saw and the cut needed, hold either the top or the bottom edge of the molding against the fence. Then cut the piece at a compound angle. Although this cut is usually called a compound miter cut, technically it is a compound miter/bevel cut. This is an important distinction because the miter and bevel cuts must be set at different angles.

When molding is cut flat on the saw, the angles needed for a 90° corner are difficult to compute and easy to forget. Fortunately, almost all compound miter saws and sliding compound miter saws have these settings distinctly marked on their scales. They are 31.62° for the miter and 33.86° for the bevel. Many saws also have the settings for crown designed with a spring angle of 45° distinctly marked.

When the crown molding has to go around a corner that's not square, the settings highlighted on the saws don't work. For these situations, most saw manufacturers provide a table of the settings for any possible corner. This table is usually included in the owner's manual. For more on measuring out-of-square walls and finding the correct compound miter settings, see "Trimming with Oblique Angles" on p. 432.

Laying Out Crown Molding

Before beginning the installation, use a scrap and a framing square to draw out the critical dimensions. Then, use these dimensions to lay out the bottom of the crown molding on the wall, to set up the saw for cutting the crown at the spring angle, and to cut backing blocks of the correct size.

STEP 1 Draw the critical dimensions

1 Place a framing square on a scrap of plywood and trace along the inside edges to draw a right angle.

2 Square-cut a piece of the crown molding about 4 in. long and place it between the legs of the square, making sure the back edges of the crown sit flush with the inside of the square.

3 Carefully trace the profile of the crown, including the back, onto the plywood.

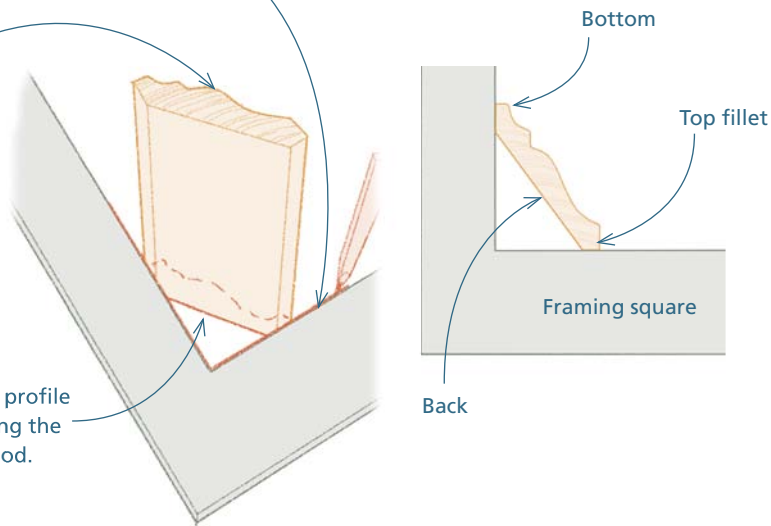

STEP 2 Lay out the bottom of the crown molding on the wall

1 Remove the square and measure the distance between the corner (formed by the right angle of the triangle) and the bottom of the crown. Cut a scrap this length.

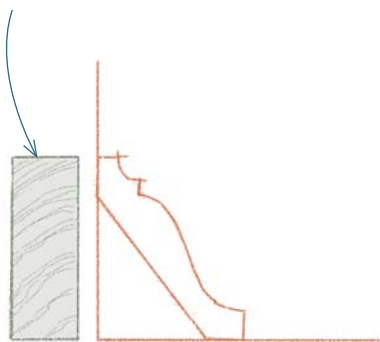

2 Use the scrap as a gauge to mark the layout for the bottom of the crown molding on the wall. At the corners and at roughly 32-in. intervals along the walls, push the block against the ceiling and scribe along the bottom.

STEP 3 Position the crown on the miter saw

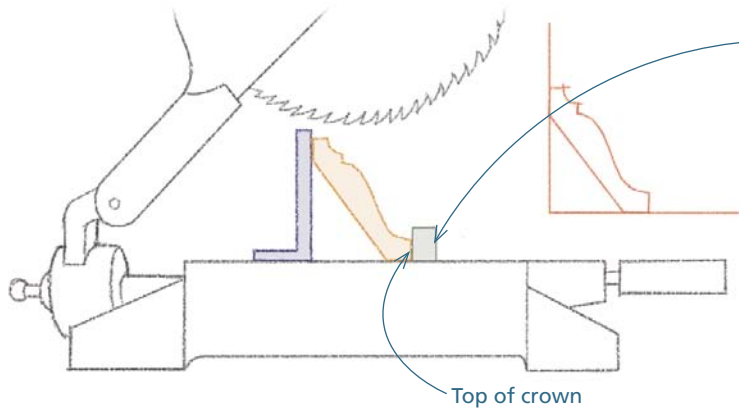

When using the nesting method to cut the crown, mark a line on the table of the saw to hold the crown molding at the proper angle. The correct distance from the fence to the line is equal to the distance from the corner (formed by the right angle of the triangle) to the face of the fillet at the top of the crown molding on the drawing.

STEP 4 Lay out backing blocks

1 If you decide to use backing blocks for installing the crown, use the triangle of the drawing as a guide. The backing blocks should be ripped at the spring angle and fit inside the triangle.

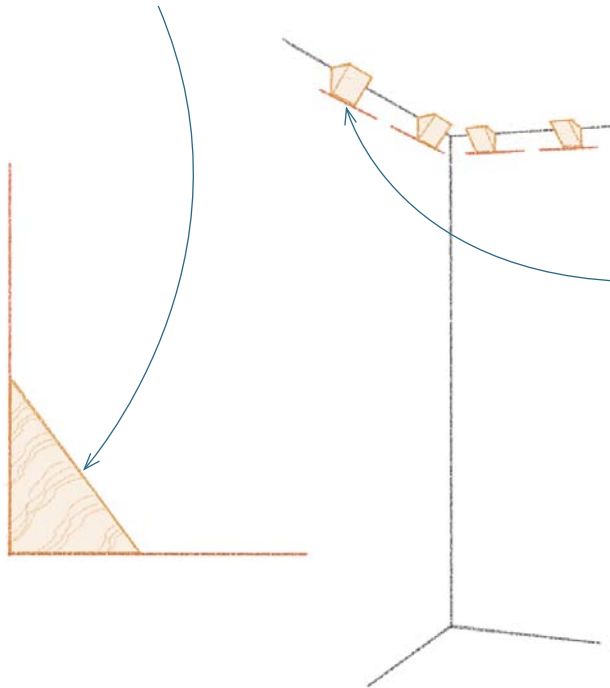

2 To avoid holding the molding out from the wall, make the backing blocks $\frac{1}{8}$ in. smaller than the triangle.

Cutting and Fitting Inside Corners

As with base and chair rail molding, the inside corners of crown molding are usually coped. And, like those other moldings, the process of marking the profile begins with a miter cut in which the molded side of the piece is the short point of the cut. Unlike those other moldings, however, the preliminary cut has to be a compound miter cut.

Cutting the cope After making the preliminary cut, darken the edge at the heel of the cut with the side of a pencil lead. This line follows the profile of the crown molding as it will be situated when both pieces are installed at the spring angle. Cut along the line with a coping saw. Check the fit against a scrap. Fine-tune the cut until the coped piece fits tightly over the scrap.

STEP 1 Make the preliminary cut

• METHOD 1: NESTING METHOD

1 Refer to the layout drawing to find out how far to lay out the stop line from the fence of the saw. It's the distance from the corner to the front of the crown molding at the top. Measure and mark the stop line on the table of the saw.

Mark table here.

3 Set the piece on the saw with the top edge of the molding down and against the stop (or on the line) and the bottom edge leaning against the fence.

4 For an inside corner on the right end of a piece, set the saw to a right 45° miter. Plan on using the portion to the right of the cut.

2 If possible, affix stop blocks to the table at the line. Most miter saws now offer accessories for this purpose. If your saw doesn't have a system for setting up stop blocks, you can simply hold the molding on the line as you cut it. Or you can fabricate a jig with a secondary table.

5 For an inside corner on the left end of a piece, set the saw to a left 45° miter. Plan on using the portion to the left of the cut.

TOP TIP

Upside Down and Backwards

.....
When using the nesting method, the piece is always placed in the saw with the top down. Since the piece is upside down and will have to be rotated 180° when it's installed, the cut is also at the opposite end of the piece as it's being cut.
.....

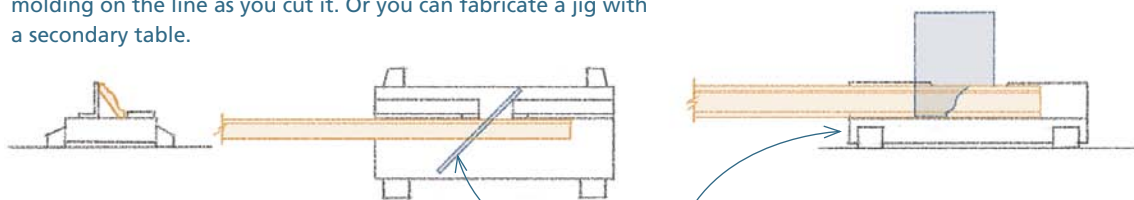
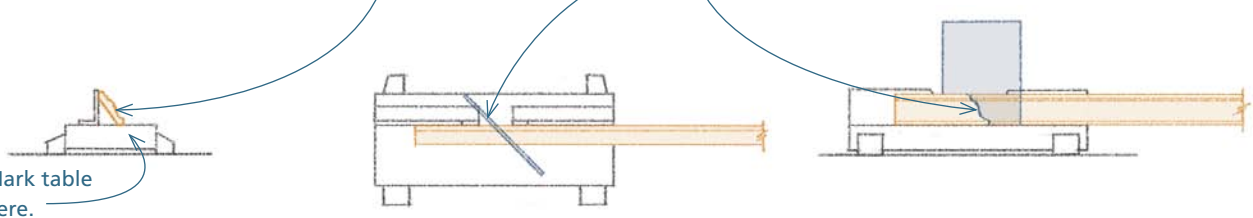
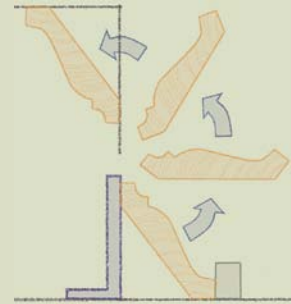

● METHOD 2: ON THE FLAT WITH A SINGLE-BEVEL SAW

For crown molding with a 38° spring angle (most crown molding), use the settings marked on your miter saw. They will be enumerated here. (For crown molding with a 45° spring angle, substitute the miter and bevel settings found in the table on p. 506 for the ones provided here.)

1 For an inside corner on the right end of the piece, set the top of the molding against the fence.

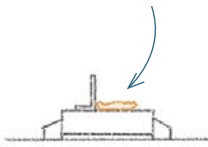

2 Set the miter to 31.62° swiveled right.

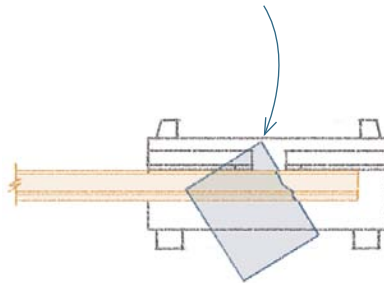

3 Set the bevel to 33.86° tilted left (single-bevel saws can only tilt left). Plan on using the portion to the left of the cut.

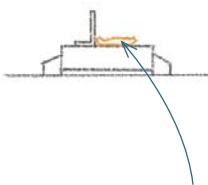
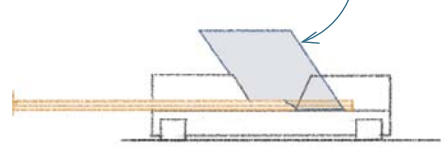

4 For an inside corner on the left end of the piece, set the bottom of the molding against the fence.

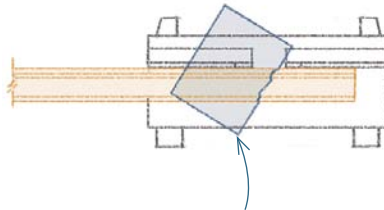

5 Set the miter to 31.62° swiveled left.

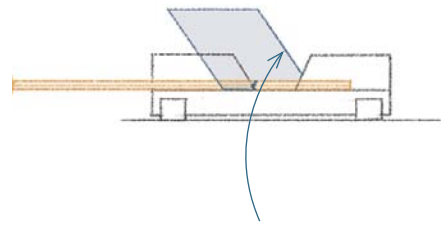

6 Set the bevel to 33.86° tilted left (single-bevel saws can only tilt left). Plan on using the portion to the left of the cut.

● METHOD 3: ON THE FLAT WITH A DUAL-BEVEL SAW

1 For an inside corner on the right end of the piece, set the miter to 31.62° swiveled right.

Both of the cuts described here start with the top edge of the molding against the fence.

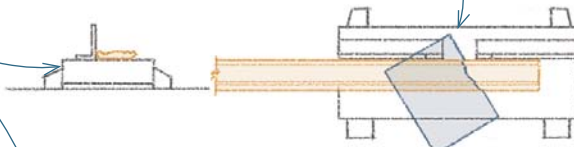

3 For an inside corner on the left end of the piece, set the miter to 31.62° swiveled left.

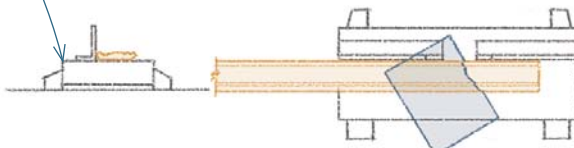

2 Set the bevel to 33.86° tilted left. Plan on using the portion to the left of the cut.

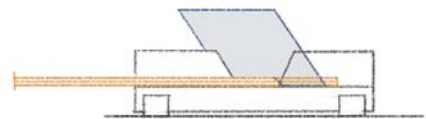

4 Set the bevel to 33.86° tilted right. Plan on using the portion to the right of the cut.

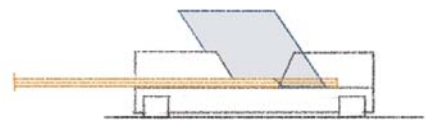

STEP 2 Measure and cut the piece to length (inside corner to inside corner)

1 To measure from an installed piece to an inside corner, place a 10-in. block against the top outside edge of the piece (the top fillet), and mark along the other end of the block. Measure from the opposite corner to the mark, and add 10 in. to the measurement.

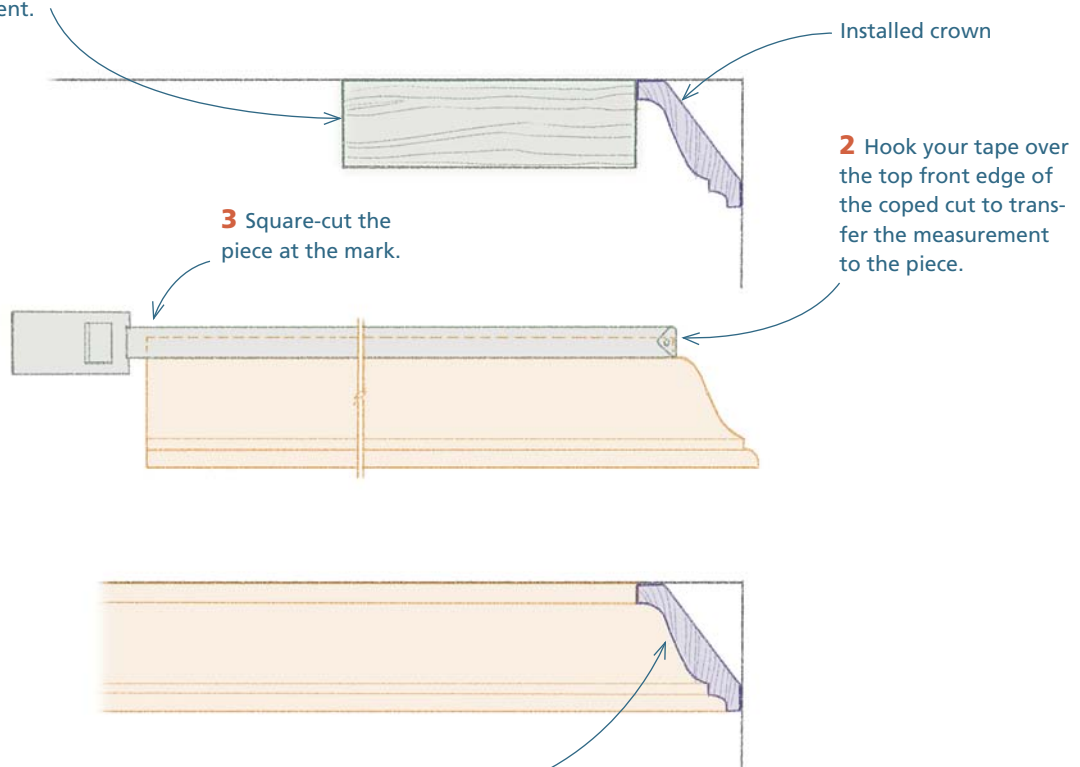

4 Hold the piece in place and check the fit at the coped end. Fine-tune the cut if necessary. When you're satisfied with the fit at the coped end, hold the piece tight to the matching piece and install it along the marks you made on the wall.

Measuring and Cutting, Inside Corner to Outside Corner

As with baseboard and chair rail molding, when the opposite end is an outside corner, leave the piece long until you get the inside corner fine-tuned. Once you're satisfied with the inside corner, hold the piece in place as you mark it at the outside corner. The two pieces that form an outside corner can be fitted by using test pieces in scrap material. (For more on this process, see step 5 of "Cutting and Fitting Baseboard Molding" on p. 417.)

Fitting Outside Corners with the Nesting Method

Fitting outside corners using the nesting method is simple because there's only one angle to adjust: the miter setting on the saw. Begin by cutting matching outside corners at 45° miters, and adjust as needed until the pieces fit tightly together at the corner. As with inside corners, these cuts must be made with the molding set upside down on the table.

1 For an outside corner on the right end of the piece, set the saw to a left 45° miter.

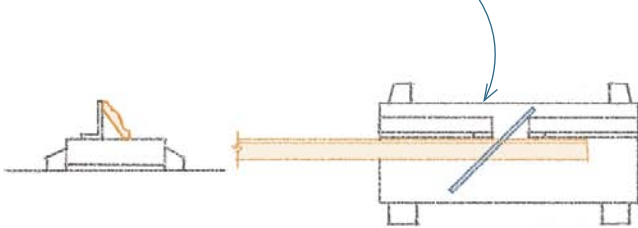

2 Use the portion to the right of the cut.

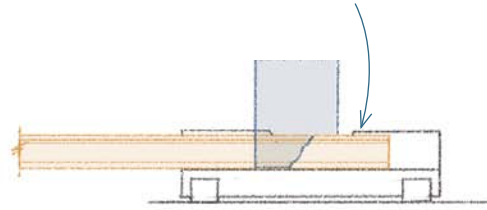

3 For an outside corner on the left end of the piece, set the saw to a right 45° miter.

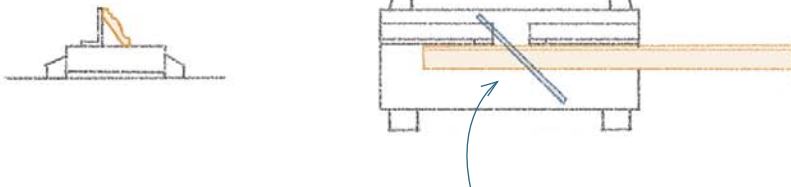

4 Use the portion to the left of the cut.

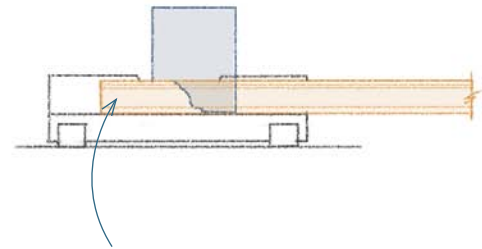

Fitting Outside Corners on the Flat

Fitting outside corners with the piece lying flat can be more difficult than doing so with the nesting method. When you use compound miter/bevel settings, both settings have to be changed for any adjustments. The settings for crown molding with a 38° spring angle going around a true 90° corner are given here. If you're using crown molding with a 45° spring angle or you have to adjust the fit of 38° crown molding, refer to the table on p. 506.

• MITER/BEVEL SETTINGS WHEN USING A SINGLE-BEVEL SAW

1 For an outside corner on the right end of the piece, set the bottom of the molding against the fence.

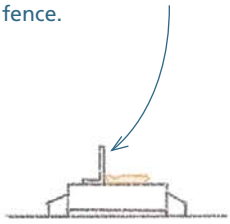

2 Set the miter to 31.62°, swiveled left.

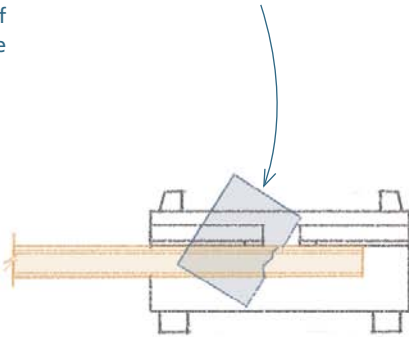

3 Set the bevel to 33.86° tilted left (single-bevel saws can only tilt left). Use the portion to the right of the cut.

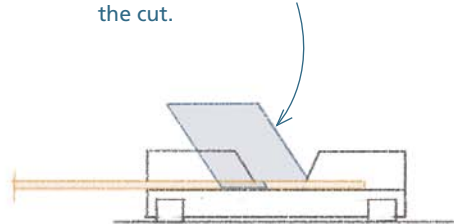

4 For an outside corner on the left end of the piece, set the top of the molding against the fence.

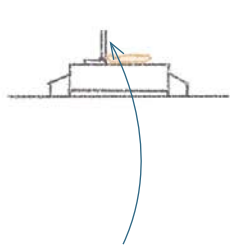

5 Set the miter to 31.62°, swiveled right.

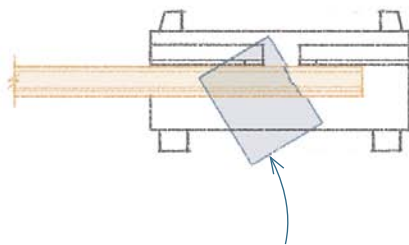

6 Set the bevel to 33.86°, tilted left. Use the portion to the right of the cut.

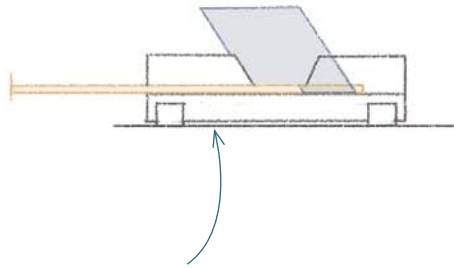

• MITER/BEVEL SETTINGS FOR A DUAL-BEVEL SAW

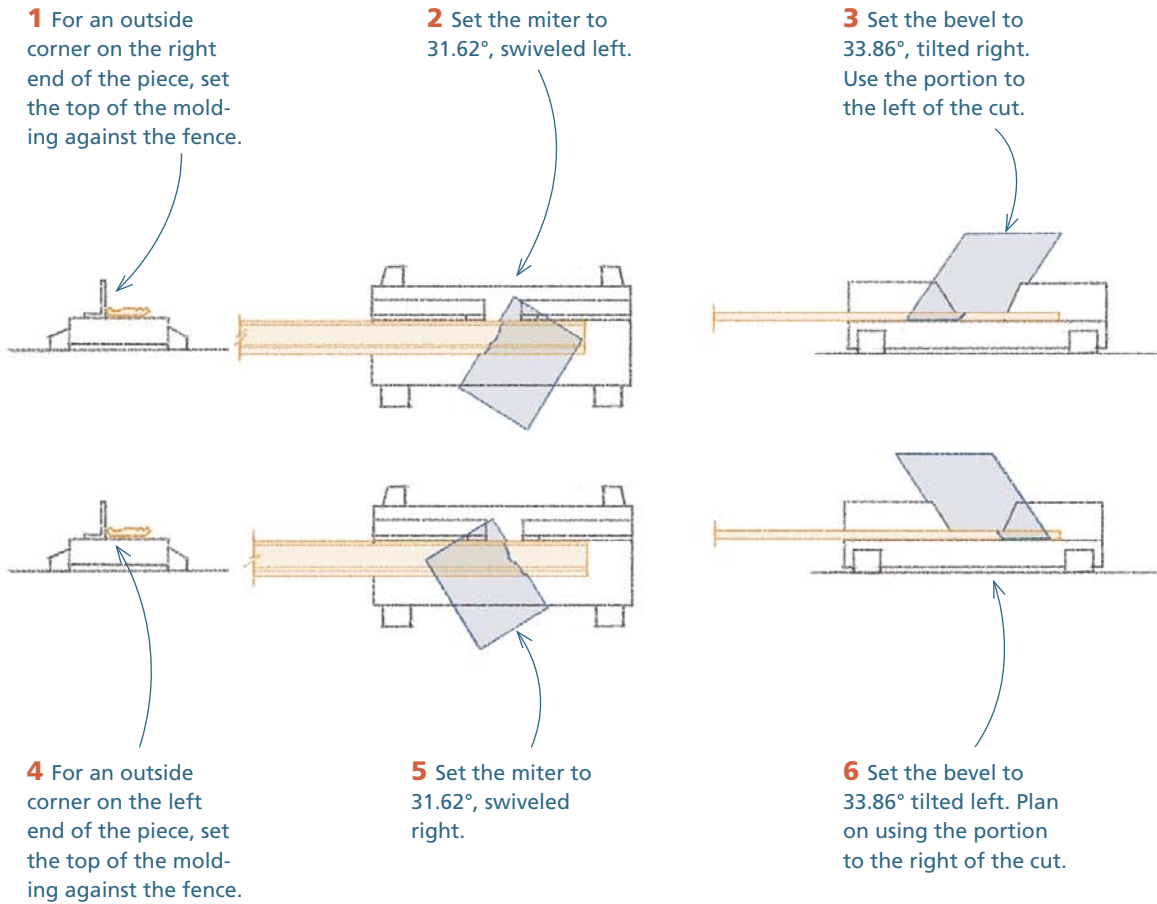

Attaching Crown Molding

Crown molding up to 3 in. wide can be attached with one $2\frac{1}{2}$ -in. finish nail driven through the center of the piece every 32 in. or so. In most cases, the top plate of the wall provides a solid nailing surface along the entire wall.

If you have trouble finding a suitable nailing base, you're installing crown that's larger than 3 in., or you just want to provide a very solid nailing base, make up and install backer blocks. Make the backer blocks as described in "Laying Out Crown Molding" on p. 425. You can normally install the backer blocks by nailing horizontally into the top plate of the wall.

Trimming with Oblique Angles

Although most of the corners inside a house are 90°, many are a degree or two out of square. In addition to these accidental out-of-square corners, there are often corners and intersections that, by design or necessity, are far from square. Designers might draw up plans with walls that turn at a 45° angle, or they might specify octagonal windows. A common spot for an oblique angle is where a skirtboard on a staircase meets the horizontal baseboard.

Whether these angles are the result of sloppy framing or the design of the house, they usually require trim. This section shows how to achieve neat, tight joints when the trim has to meet at oblique angles.

Bisecting the Angle

Carpenters use the same basic technique to join trim at oblique angles that they use for right angles. The essence of this technique is to bisect the angle at the miter joint. With a true 90° angle, of course, the two pieces are cut at 45° miters. With oblique angles, the trim must be miter-cut at an angle that's exactly half of the angle at which the trim turns. The challenge is to find that angle.

In some cases, the correct miter is not too hard to find. When casing out an octagonal window, most carpenters can see that the jamb turns at a 45° angle. The miter setting, then, is 22½° (or close to that setting). In other cases, the correct miter is not apparent and has to be measured. There are several ways to measure the bisecting angle. Here are two simple approaches.

Method 1: Trial and error. If you have a rough idea of the angle, you can quickly determine the correct miter by making test cuts in scrap material. If an outside corner is slightly out of square, you can start with 45° cuts on two scraps. If these pieces don't fit together properly, adjust the miter slightly and try again. Repeat until you arrive at a perfect fit.

Method 2: Measure the angle with a scrap and two squares. Another way to measure the bisecting angle is to draw it in place, transfer it to a board, and measure it. To measure the bisecting miter angle needed for base cap molding that turns from the horizontal to the sloping angle of the stair skirt, follow these steps.

TOP TIP

Defining Angles

.....
All angles that are not right angles (90° angles) are called oblique angles. Oblique angles can be acute (less than 90°) or obtuse (more than 90°).
.....

• MEASURE THE ANGLE WITH A SCRAP AND TWO SQUARES

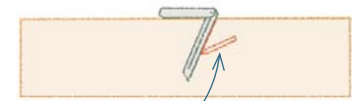
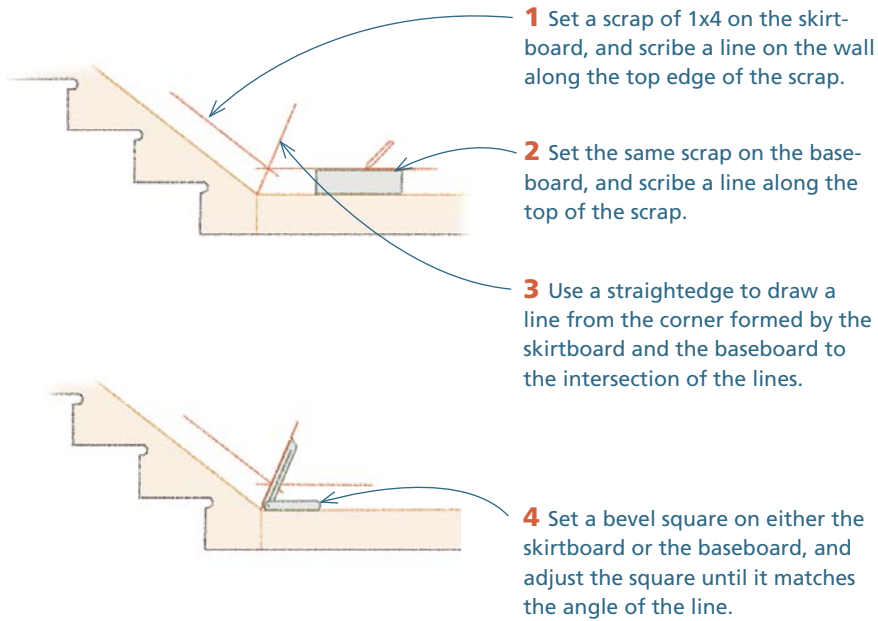

5 Transfer the angle on the bevel square to a flat board.

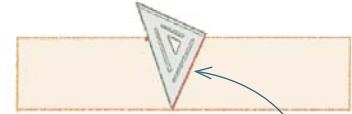

6 Measure the bisecting miter angle with a Swanson Speed Square, a Stanley Quick Square, or a C. H. Hanson Pivot Square. (You can also measure the angle with a protractor and subtract it from 90° to get the bisecting miter angle.)

• USE MITERS TO JOIN OBLIQUE INSIDE CORNERS

1 It's difficult to cope inside corners when the angle is substantially greater than 90°. The cope must be back-cut at a very steep angle to allow the coped piece to overlap the installed piece.

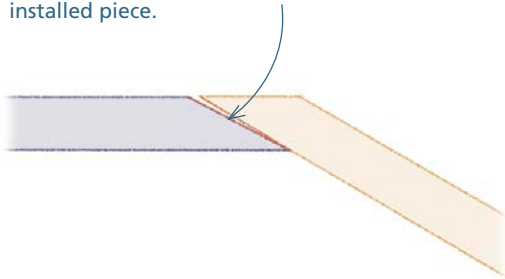

2 It's more practical to cut matching miters for these joints. After measuring the bisecting angles, use test pieces to fine-tune the fit.

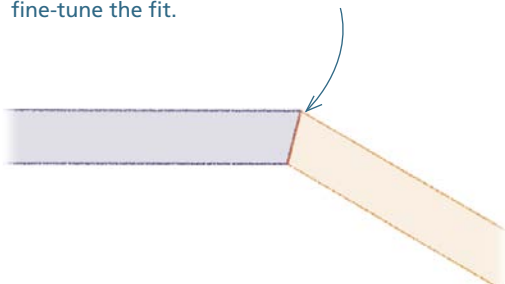

Running Crown Molding around an Oblique Angle

The simplest way to run crown molding around oblique corners is to use the nesting method. If the crown is too big to fit in the nested position, however, you may have to lay it flat and use compound miter/bevel cuts.

Using the nesting method Use a piece of 1x4 scrap to draw lines parallel to the wall on the ceiling. The lines should intersect outside of the corner. Use the method described in “Measure the Angle with a Scrap and Two Squares” on pp. 432–433 to determine the bisecting angle of the walls. Set the crown in the miter saw upside down and leaning against the fence at the spring angle. Set the miter to the bisecting miter angle to cut inside or outside corners.

• CROWN AROUND OBLIQUE ANGLES: MAKING THE CUTS ON THE FLAT

1 Begin by determining the angle between the walls. This angle is different from the bisecting miter angle!

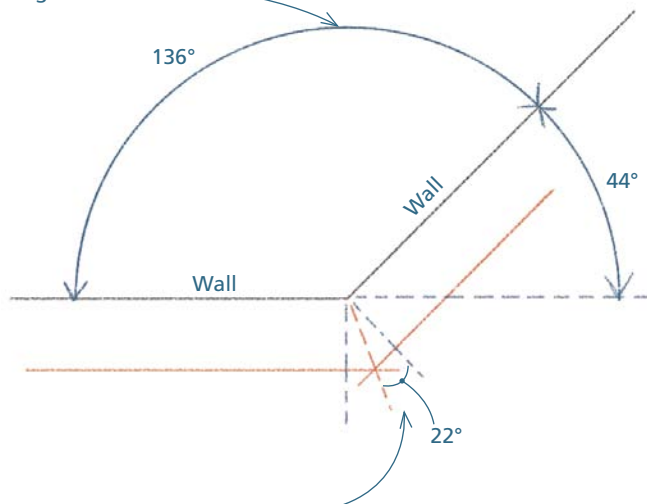

2 However, you can use the bisecting miter angle to compute the angle between the walls; the process is described in the Top Tip at right. It's faster to use a bevel square to transfer the angle to a board and then measure it with a protractor, as shown. You can also invest in any of several special tools for measuring this angle.

TOP TIP

Using the Bisecting Miter Angle to Find the Angle between the Walls

.....
If you know the bisecting miter angle, double it and then subtract the total from 180° to find the angle between the walls. If the bisecting miter angle is 22°, for example, you know that the wall turns at 44°. Subtract that from 180° to find the angle between the walls, which in this case is 136° (180 – 44 = 136).
.....

3 Once you have the angle between the walls, look up the correct miter and bevel settings for that angle in the table on p. 506. If you're using 38° crown molding and the angle between the walls is 136°, for example, the settings are 13.97° miter and 17.17° bevel. These settings would be good for either an inside or an outside corner.

Installing Cabinets

Kitchen and bathroom cabinets generally follow trim. Cabinets usually arrive in a single “cabinet package,” which should include a complete list of cabinets and accessories and a plan for the kitchen installation. (Bathroom cabinets usually don’t require a plan.) First, make sure everything on the list has, in fact, been delivered. Second, check the dimensions on the plan against the actual dimensions of the kitchen.

Thinking Through the Job

At this point, it’s always a good idea to review the plan. Look for potential problems and pitfalls and establish the critical dimension of the installation. Here are a few things to think about now and as you install the cabinets.

● CHECK FOR DRAWER CLEARANCE

A common error is not to leave enough room for drawers at the inside corners of base cabinets. The thickness of the doors and the projection of doorknobs and drawer pulls can prevent the drawers on the other side of the corner from opening. Other trouble spots:

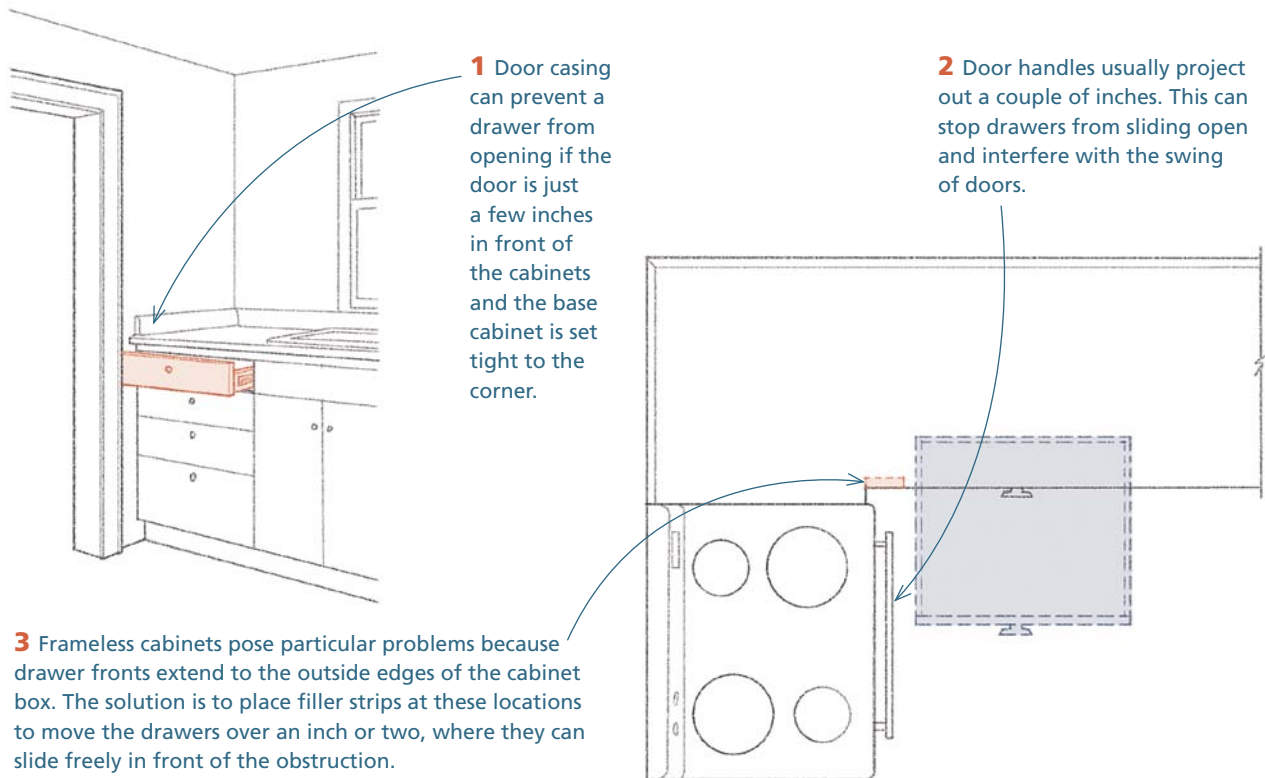

TOP TIP

Don't Forget the Finish Floor

.....

If you install the base cabinets on the subfloor and the finished floor ends up $\frac{3}{4}$ in. thick, you may not be able to squeeze the dishwasher in later. To avoid this problem, find out what floor covering is planned and how much it will raise the floor. Use plywood of that thickness to raise the area under the base cabinets the required amount.

.....

Leave Room for the Appliances

As you install the cabinets, you must leave openings for the appliances. The sizes of these openings are critical. If the openings are too small, you won't be able to fit the appliance into place; if the openings are too big, there will be an unacceptable gap around them.

- **Dishwasher:** Most dishwashers are 24 in. wide. To play it safe, many installers make the opening 24¼ in. wide. The height of the opening should be 34½ in., which is the height of a standard base cabinet. The most common alternate width is 18 in.

- **Range:** Most ranges are 30 in. wide. Many installers make the opening 30¼ in. wide. The height is not an issue because the top of the range sits above the top of the countertop. There are several alternate widths, including 20 in., 24 in., 36 in., 40 in., and 48 in.
- **Refrigerator:** There is no standard size for refrigerators, so you need to find out what will be used. Unlike other appliances, the refrigerator is not installed. Rather, it's placed loosely in a niche where it can be easily rolled in and out of place. The opening for the refrigerator, therefore, does not need to be as tight as for the other appliances. Kitchen planners often leave a 1-in. to 2-in. space on the sides of refrigerators and several inches above them.

Laying Out the Job

Before installing the cabinets, you have to lay out level lines on the walls for the base cabinets and the wall cabinets (see the drawing on the facing page). You also have to mark the locations of the studs. If you need to build up the floor below the base cabinets to allow for the thickness of the floor covering, you need to lay out those areas, too.

Attaching Cabinets to the Walls

The cabinets should be securely attached to the walls and to one another with screws. In addition to avoiding the problems discussed on p. 435, the cabinets should be installed level and with the face frames flush to one another. If the cabinets don't have face frames, the front edges of the cabinet boxes should end up even.

Some carpenters prefer to install all the wall cabinets before they install the base cabinets. Other carpenters find it easier to install the base cabinets first. Both methods work. The drawings on pp. 438–441 follow the more common sequence of installing wall cabinets first. In general, the installation should run from inside corners toward the outside and from critical dimensions to noncritical dimensions. As we've seen, the opening for a dishwasher or range is a critical dimension. An example of a noncritical dimension might be when a line of cabinets ends several inches away from a door or window casing. An inch or two doesn't matter much.

TOP TIP

Remove Drawers and Doors

To reduce the weight of the cabinets and to minimize damage, remove the doors and drawers from the cabinets before you hang them. Most cabinets now come with Euro hinges, which are easy to take off. Store the doors and drawers in a safe place to avoid damaging them.

STEP 1 Mark a level line for the base cabinets and wall cabinets

- 1** Find the highest point on the floor in the area where the base cabinets will be installed. The best tool for this is an accurate laser level, but if you don't have one, use a builder's level or a reliable spirit level.
- 2** If the finished floor has not been installed, add the thickness of the planned floor covering, including any underlayment, and mark a point on the wall up 34½ in. from the highest point on the floor.
- 3** Use a laser level, a builder's level, or a spirit level to extend a level line from this mark.
- 4** Measure and mark a distance equal to the thickness of the countertop above the line you made for the base cabinets. The standard thickness of plastic laminate countertops is 1½ in.
- 5** Measure and mark 18 in. up from the mark representing the top of the countertop (this standard is common but not absolute).

- 6** Starting at this mark, snap a level line on the wall where the wall cabinets will be installed. You can use the line you've already drawn for the base cabinets as a level reference. Usually, this means measuring and marking a parallel line that's 19½ in. above the base cabinet layout line.

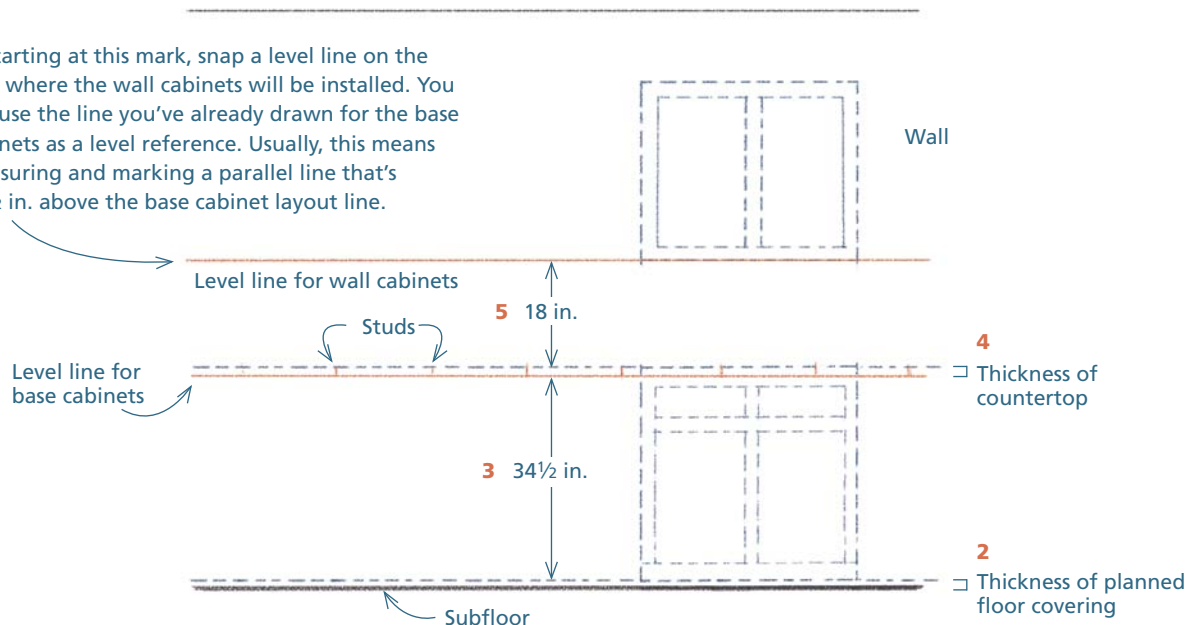

STEP 2 Mark the locations of the studs

Mark the positions of the studs on the wall just above the level layout line for the base cabinets. You don't have to worry about marks or holes made in this area because it will be covered later by the countertop.

STEP 3 Lay out the locations of the base cabinets

If you have to raise the base cabinets to allow for the thickness of the finish floor, mark the exact position of the base cabinets on the floor. Measure the depth of the base cabinets at the bottom; in standard cabinets, this distance is typically 21 in. Strike a chalkline this distance out from the walls where the base cabinets will be set. Carefully mark the locations of the base cabinets and spacers along the line.

Screws for hanging cabinets Use 3-in. cabinet hanger screws to attach cabinets to the wall. The manner in which cabinets are attached to each other depends on whether they have face frames or are frameless. Traditional American cabinets with face frames can be held together with #8 flat-head steel screws. Make sure the screw is long enough to extend through one face frame and about 1 in. into the other but not so long as to come through the other side. Frameless cabinets, often called European cabinets, should be connected to each other using special cabinet-connecting screws, which fit into the predrilled shelf-pin holes. If you can't buy these screws locally, you can order them at McFeely's® (www.mcfeelys.com).

STEP 1 Hanging the first wall cabinet

Install the first cabinet at an inside corner. Measure stud locations and predrill the hanging strips at the top and bottom of the cabinet. Hold the cabinet on the line, and drive the screws through the pilot holes and into the studs.

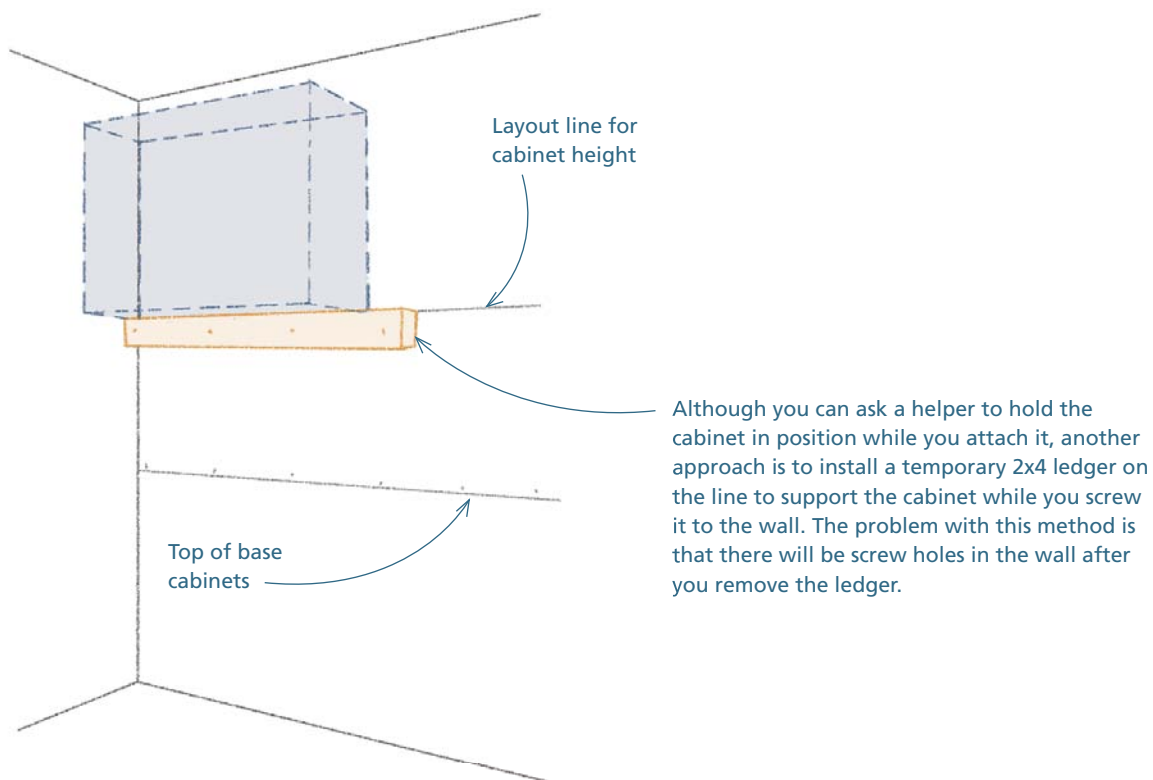

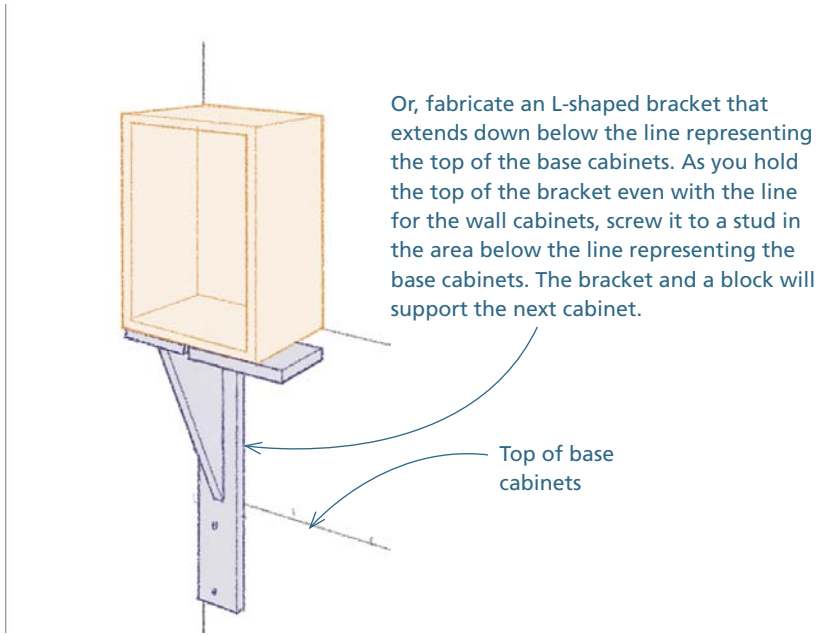

TOP TIP

Supporting Upper Cabinets the Easy Way

.....

The quickest and easiest way to hold up the cabinets is to use a manufactured tool designed specifically for that purpose. The T-JAK® (www.tjak.com) is a simple support that can be set to roughly the desired height and then finely adjusted to bring the cabinet even with the line. It's well worth the investment if you anticipate installing cabinets on a regular basis.

.....

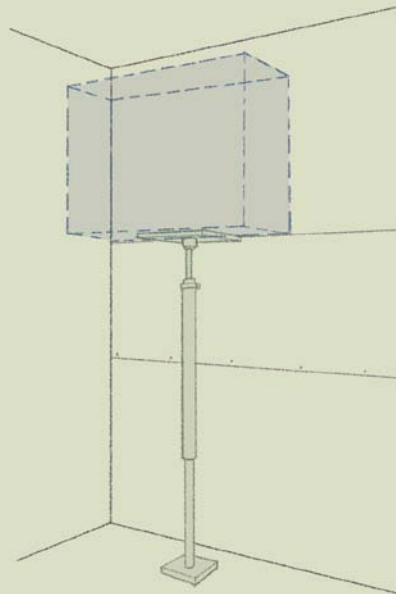

STEP 2 Hanging subsequent wall cabinets

Before you set the cabinet in place, carefully measure the location of the stud or studs from the side of the installed cabinet. Transfer the measurement to the hanging strips, and drill pilot holes for hanging screws.

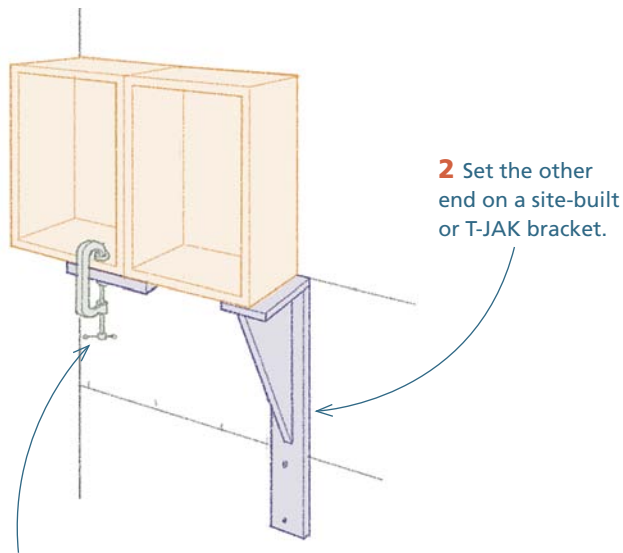

1 Use the first installed cabinet to support the next one down the line by clamping a scrap to the bottom of the installed cabinet with a few inches extending past the side. Set one end of the next cabinet on the scrap.

3 If the cabinets have face frames, clamp the face frames of the two cabinets together near the top and bottom.

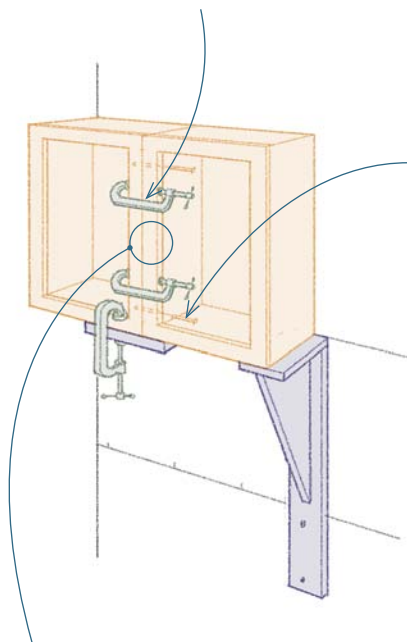

4 As the clamps begin to get snug, adjust the face frames in and out until they're flush. After you get the face frames flush, pull them tight together with the clamp.

5 Near each clamp, drill a $\frac{7}{16}$ -in. pilot hole through the inside edge of one face frame and into the other. Countersink the holes, then drive two #8 flat-head screws to hold the face frames together.

8 Once the cabinets are connected to each other, screw the cabinets to the wall.

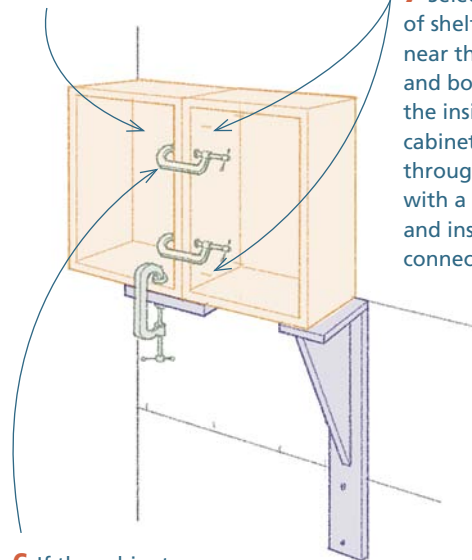

7 Select a couple of shelf-pin holes near the top and bottom on the inside of the cabinets. Drill through the holes with a 5mm bit, and install a pair of connecting screws.

6 If the cabinets are frameless, clamp the sides of the boxes together, making sure the front edges are even.

STEP 3 Installing base cabinets

1 If you need to install plywood to raise the level of the cabinets, do so now. Double-check the layout to make sure the plywood ends up even with the outside edges of the cabinets.

2 Start the installation of base cabinets at an inside corner.

3 Since the 34½-in. line was referenced at the highest point in the floor, you'll need to shim many of the base cabinets to keep them even with the line.

4 Attach the cabinets to the studs with 3-in. cabinet-hanging screws. After attaching each cabinet at the line, check for level from front to back, shimming as needed to get the front level with the back.

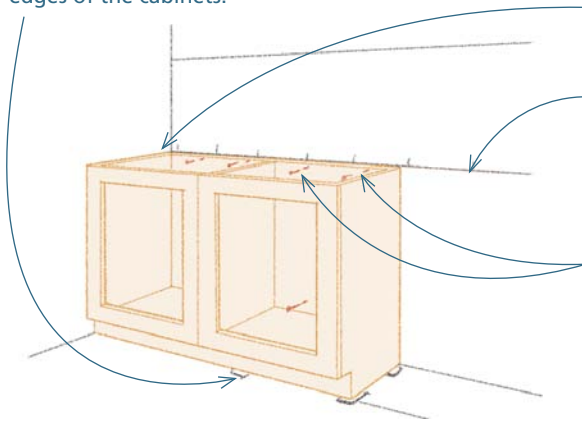

5 When the cabinets have face frames, the stiles of the frame extend about ⅛ in. beyond the sides, creating a ¼-in. space between the sides of adjoining cabinets.

6 Insert shims from the top into the space between the cabinets, then tie the two cabinets together with a short screw. This screw should be installed in the top inch close to the back of the cabinet.

7 As with wall cabinets, screw the fronts of the cabinets together. Make sure the face frames or the front edges of frameless cabinets are flush when you screw them to one another. Also, attach the cabinets to one another toward the back.

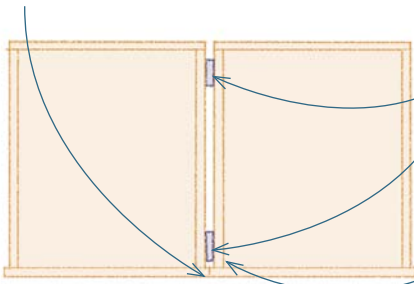

STEP 4 Cutting and fitting filler strips

1 Filler strips, which match the outside faces of the cabinets, move cabinets away from corners so drawers can open, and they expand the overall length of a cabinet run so boxes fit neatly into a given space. Standard cabinets are manufactured in 3-in. increments. When the space isn't a perfect multiple of 3, a filler makes up the difference.

2 Filler strips can be used between cabinets or at the edge of openings. After cutting the filler strip to the desired width (best done on a tablesaw), clamp it to the edge of the face frame (or to the side of frameless cabinets), and attach it with flat-head screws.

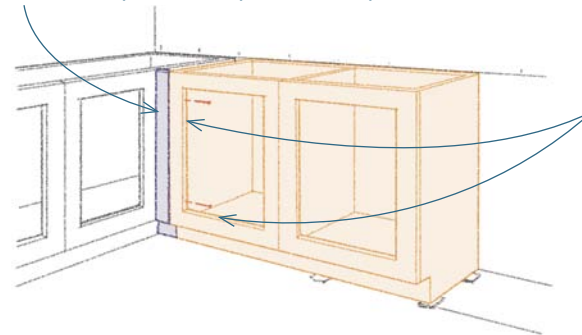

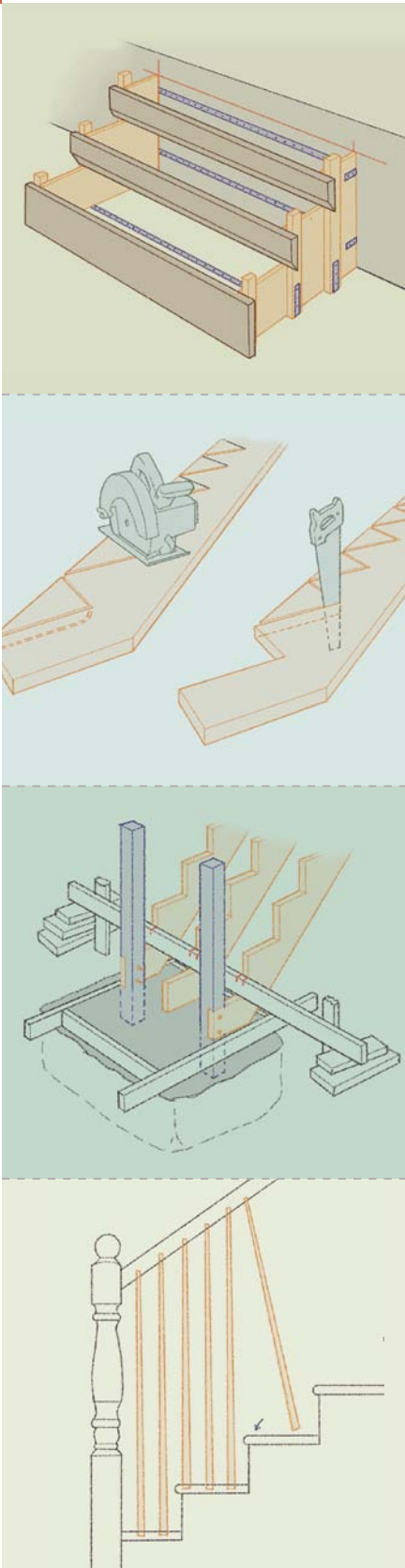

Building Stairs

MANY HOUSES HAVE BOTH interior and exterior stairs. Outside, stairs are usually placed directly on the soil and face the brunt of the weather. To endure these harsh conditions, they have to be made from tough materials. Inside the house, stairs are protected from the weather and can be built with materials chosen for their beauty. Both kinds of stairs are subject to the same code provisions. This means that many of the methods and approaches used with exterior stairs can be applied to stairways inside.

This chapter begins with the general characteristics of stairs. Then it describes the layout and construction of several kinds of exterior stairs. The final section shows how the lessons learned from building exterior stairs can be used to build interior stairs.

General Characteristics of Stairs

Before getting into the specifics of exterior and interior stairs, it's helpful to familiarize yourself with the names of the most common parts of stairways, the basic terminology of stair building, and the dimensions of stairs.

● STAIR PARTS

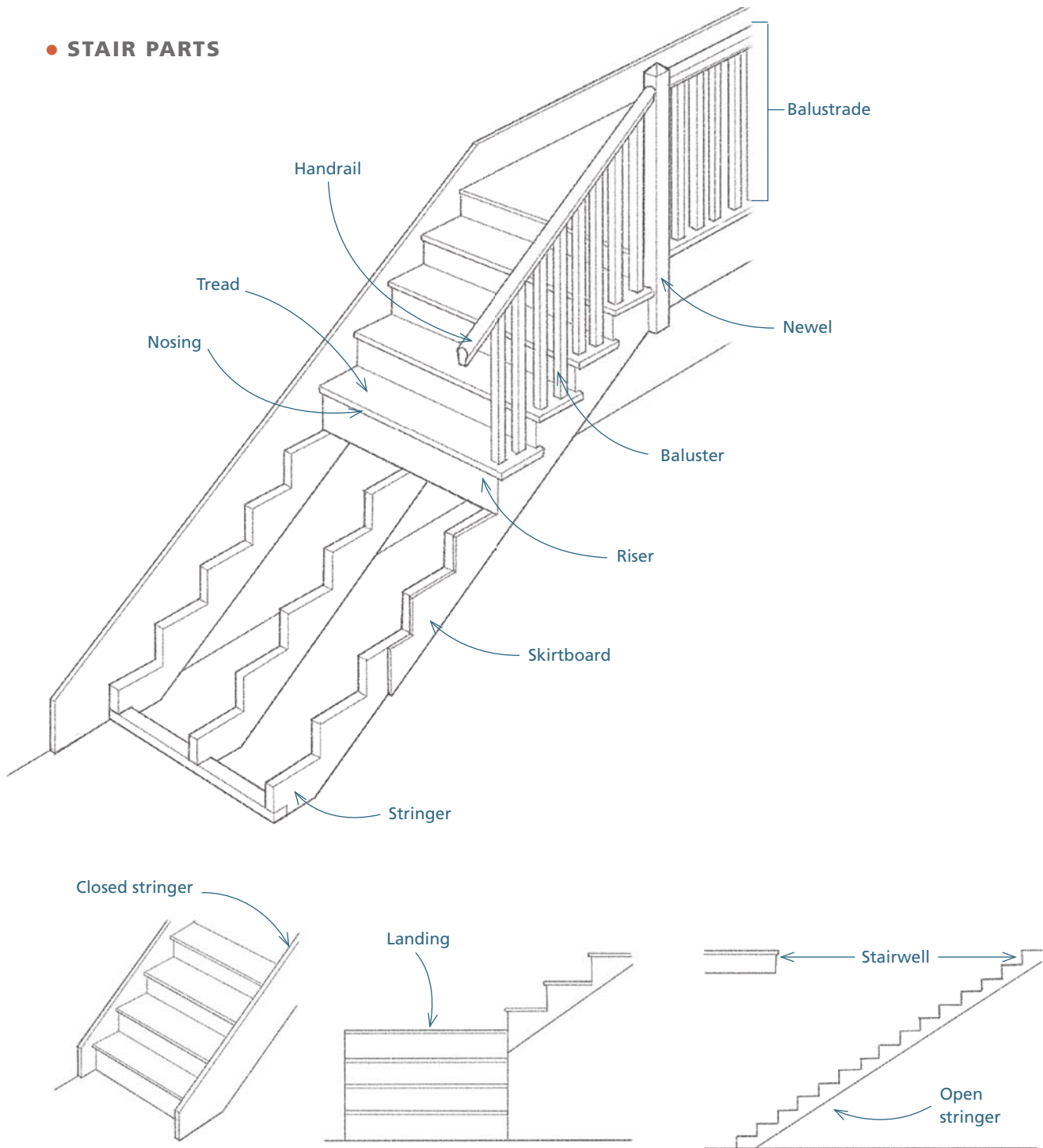

● STAIR-BUILDING TERMINOLOGY

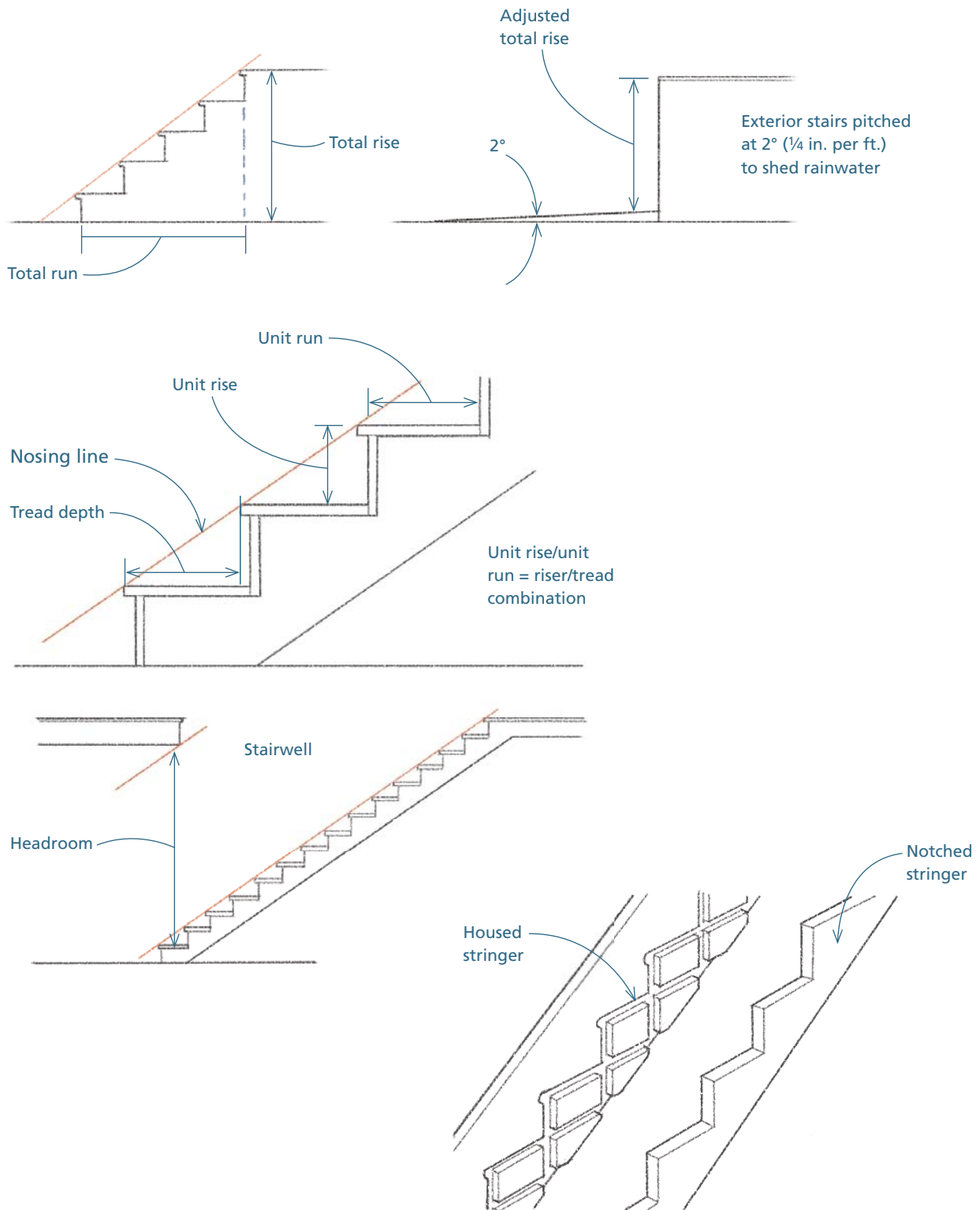

● KEY DIMENSIONS

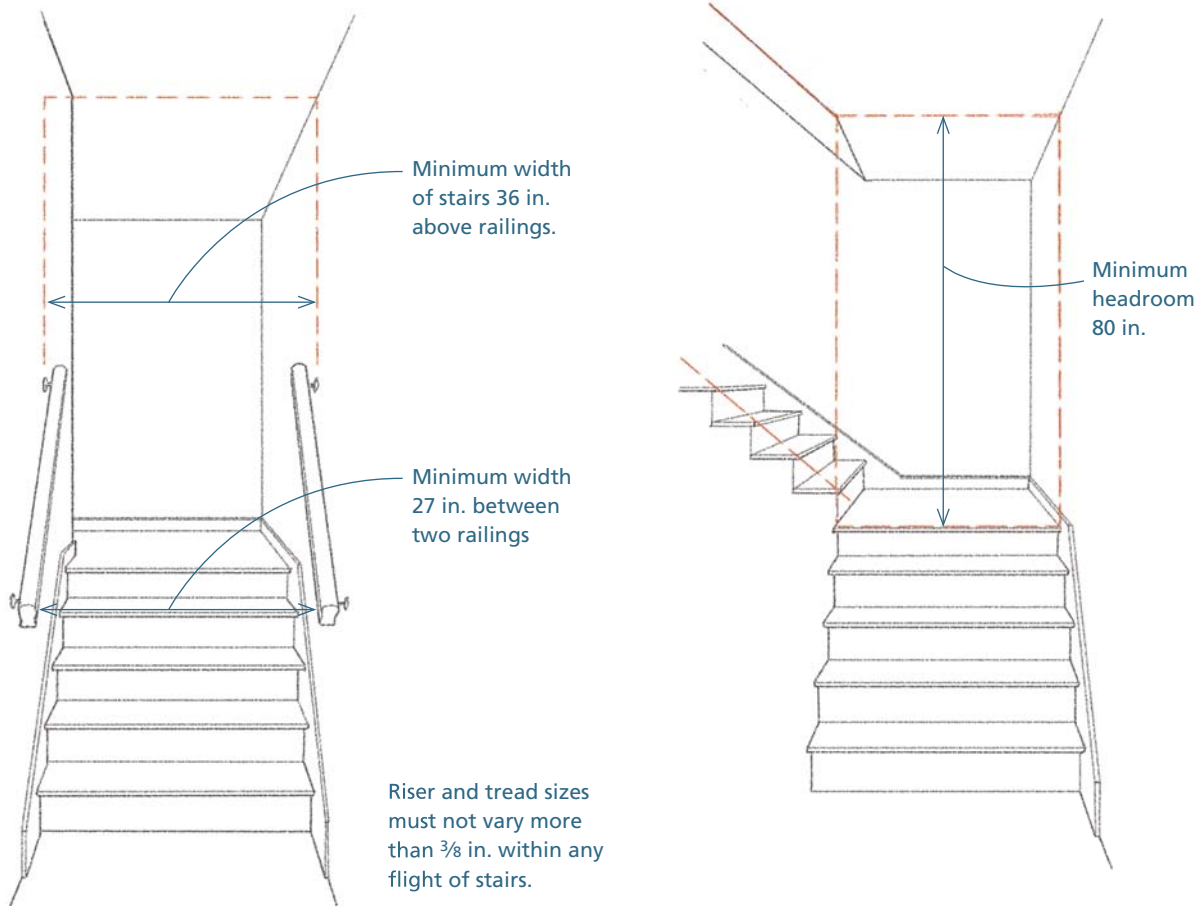

Dimensions of Stairs

Of all the architectural elements in a house, none is built on more of a human scale than the stairway. Developed over thousands of years, the dimensions of stairways fit the size of our hands and feet and the way we walk. The main reason for this close connection is the inherent danger of climbing up and down stairs. Building scientists generally agree that the stairway is the single most hazardous architectural element in a house. By carefully matching the stairs to the people who use them, building codes have striven to reduce the risks.

Stairs also are relatively difficult to traverse, especially for the small, the infirm, and the old. We can never make stairs easy for everyone to use. But by building within a limited range of dimensions, we can make them comfortable for most people.

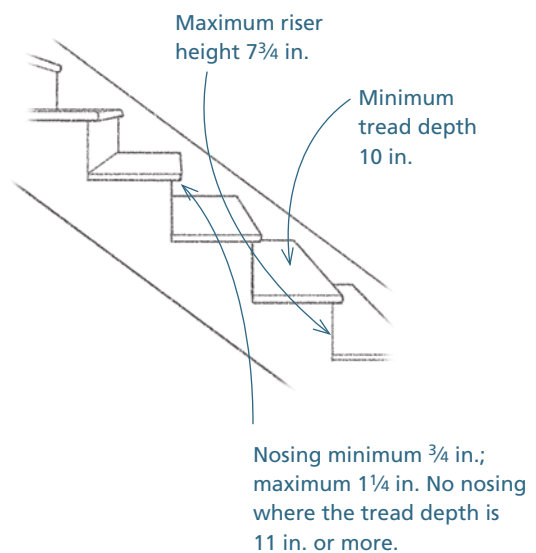

In addition to building stairs and stair rails within a prescribed range of dimensions, you have to build them to consistent dimensions. People are creatures of habit, so consistent, predictable stair dimensions substantially reduce the chance of an accident.

One dimension specified in building codes that's not directly related to the proportions of humans is the width of the stairs. If stairs only needed to accommodate people, they could be much narrower than they are. But stairways also have to allow for the passage of furniture, appliances, and other bulky items.

● RAIL AND GUARDRAIL DIMENSIONS

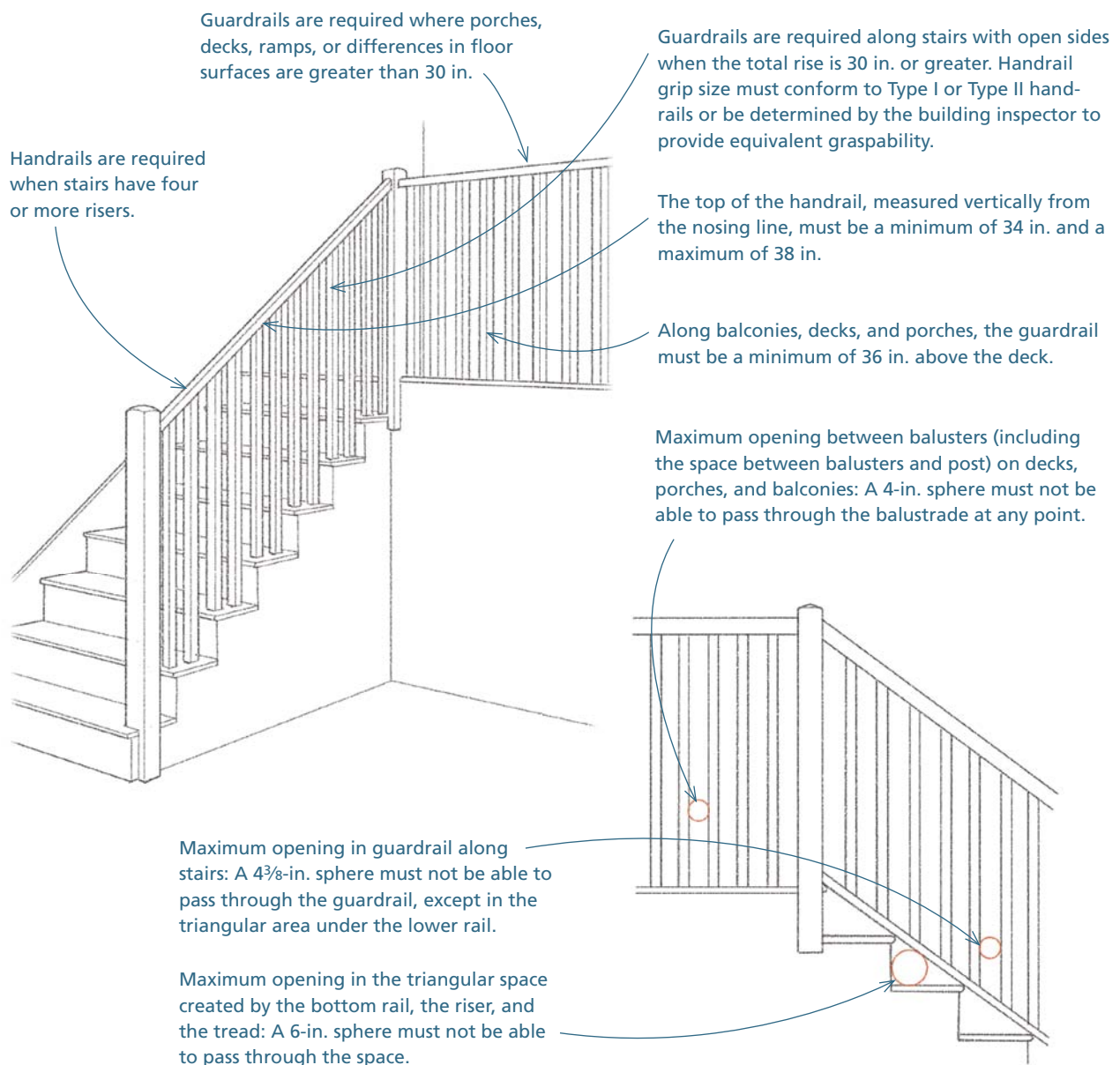

WAYS OF WORKING

Choosing a Riser/Tread Combination

The International Residential Code (IRC) requires that riser heights be no more than $7\frac{3}{4}$ in., but it doesn't stipulate a minimum riser height. It requires that tread depth be at least 10 in., but it doesn't stipulate a maximum tread depth. Other building codes specify a minimum riser height of 4 in. or 5 in. Always check your local building code before choosing a riser/tread combination.

Building codes are focused on preventing stairs that are too steep. Yet it's possible to stay within these limits and lay out a stairway that's awkward to use, unnecessarily expensive, or both. A stairway with 2-in. risers and 30-in. treads, for example, is within the specifications of the IRC, but it would not be a comfortable or practical stairway. Beyond laying out stairs that meet the building code, you should try to make the stairs within well-established comfort zones. At the same time, you can choose riser/run combinations that save time and money.

Make the stairs comfortable to use

The Stairway Manufacturers' Association (SMA) says stairs should ascend at an angle between 20° and 38° . Within that zone, the stairs are comfortable for most

people to use. If you're thinking about a riser/tread combination, you can find the angle mathematically, by measuring it, or by referring to the table on p. 508.

To find the angle mathematically, use the formula: riser \div tread depth \times \tan^{-1} . To measure the angle, see the drawings below left.

While the 20° to 38° range is great for stairs with a minimum riser height of 6 in., it doesn't work when you want to make the riser less than 6 in. high. When you build stairs with a shorter rise than 6 in., use the "Rule of Proportion." It states:

$$2 \text{ risers} + 1 \text{ tread} = 24 \text{ in. to } 26 \text{ in.}$$

Suppose you are building a set of stairs on a bank that slopes at 14° . You could build a code-complying set of stairs with 4-in. risers and 16-in. treads. This combination matches the 14° slope of the bank, so it is outside the 20° to 38° range. But it meets the Rule of Proportion ($4 + 4 + 16 = 24$) and it produces a very comfortable stairway.

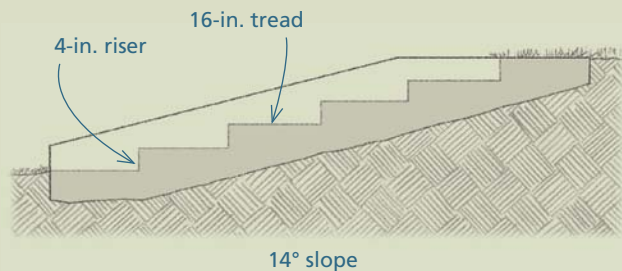

1 To measure the angle of a stair, use a framing square to draw a right triangle with an altitude equal to the riser height and a base equal to the tread depth.

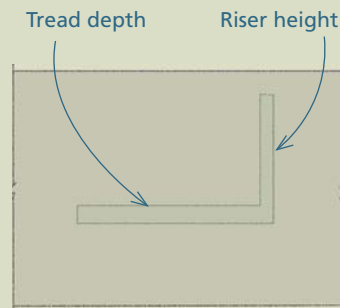

2 Measure the angle formed by the base and the hypotenuse with a protractor.

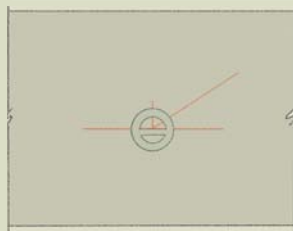

Choose a combination that saves time and money

Within these parameters, you can often save time and money—without sacrificing safety or comfort—by laying out the riser and/or the tread depth to match the size of materials. This is especially true for exterior stairs, where the total run is usually not limited and the total rise can be adjusted by altering the grade slightly.

Building Exterior Stairs

Exterior stairs are subjected to a wide range of environmental assaults, from blistering summer heat and winter ice to rain and wide swings in humidity. In snow country, they're often subjected to heavy snow loads; in hot, humid areas, they're vulnerable to rot and termite infestation. Because of these conditions, exterior stairs should be built with tough, durable materials. Masonry and concrete are common choices, particularly for short sets of stairs built directly on the ground. Wood is also a common choice, especially for longer stairways. Building codes usually require chemically treated wood or a wood species that's naturally resistant to rot and termites.

No matter what material is used, exterior stairs built on the ground have to be protected from frost heave. The most common way to do this is to place the stairs on structural points that bear on soil below the frost line. Another approach is to focus on draining away the water that causes frost heave in the first place.

Masonry Stairs

Stairs can be made from bricks, concrete masonry units (CMUs), stone, or a combination of these materials. Bricks are popular for exterior stairs because of the way they look, their durability, and because the size of bricks conforms nicely to the required riser height. You can save money on material by using CMUs the same thickness as the bricks for fill-in areas that won't be visible in the finished stairs.

• BRICK STAIRS

Brick stairs are typically made in horizontal layers. Each layer consists of two courses. The following example complies with code, falls within the limits of the Rule of Proportion, and slopes at a gentle 29° angle.

5 Allow 12 in. for the depth of each tread, which is not only a comfortable depth but also eliminates the need for a nosing.

4 In the second course, bricks are laid on edge in a rowlock course. This combination totals 6⁵/₈ in. to 6³/₄ in., which is ideal for a stair riser.

3 In the first course, bricks are laid flat.

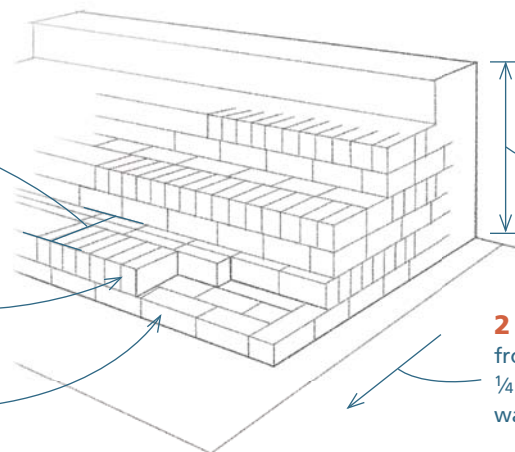

1 To start, measure down in 6⁵/₈-in. increments from the top to establish the height of a supporting slab.

2 Pitch the slab down away from the house at a rate of 1/4 in. per foot to encourage water to drain off the surface.

Poured Concrete Stairs

Unlike masonry stairs, which should be laid out to fit the size of the units, poured concrete stairs can be made to any size. When there are just a few steps, they're often poured in a solid mass with a level bottom. To save money on concrete, you can use rubble to fill some of the space inside the stairs. For rubble, always use mineral material, such as broken concrete, bricks, CMUs, or stone. Don't use dirt or organic material.

For longer sets of stairs, the concrete can be formed with a sloping bottom. In commercial construction, free-spanning concrete stairs with a sloping bottom are often used to span between two bearing points. In residential construction, free-spanning concrete stairs are rare.

Building concrete stairs with a level bottom Building concrete stairs is a two-part process: laying out and building a form, and pouring and finishing the concrete. Forms for concrete stairs must be laid out carefully to ensure the finished stairs comply with the code. At the bottom, the grade is adjustable. The best reference for the layout, therefore, is a line established at the top. From there, the layout is made from the top down.

In the instance shown here, we're building a small set of stairs leading up to a masonry porch. During construction of the porch, footings and bearing walls were built to support the stairs. The area inside and around the bearing walls has since been backfilled with drainable material.

● CONCRETE STAIRS

STEP 1 Measure the total rise

Set a level on the edge of the porch, and measure up from the grade to the level. In this example, the measurement is 21½ in.

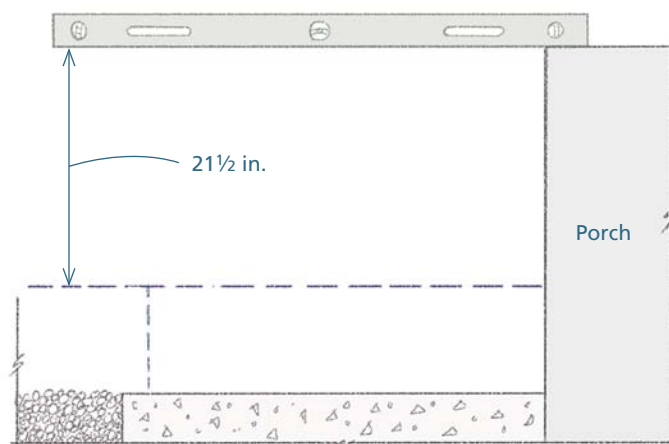

STEP 2 Factor in the pitch of the tread surfaces

At first glance, it would seem that three risers a little over 7 in. high would work here. But that assumes that the treads will be level. By code, treads have to be pitched 2% (or $\frac{1}{4}$ in. per foot) to shed water. Carpenters often lay out the risers and treads and then taper the treads $\frac{1}{4}$ in. before cutting the forms. If you do it that way, the riser at the top will be $\frac{1}{4}$ in. taller than the other risers. To avoid this problem, subtract $\frac{1}{4}$ in. per step (including the final step up to the porch) from the total rise. Since there are three steps, subtract $\frac{3}{4}$ in. This is the adjusted total rise.

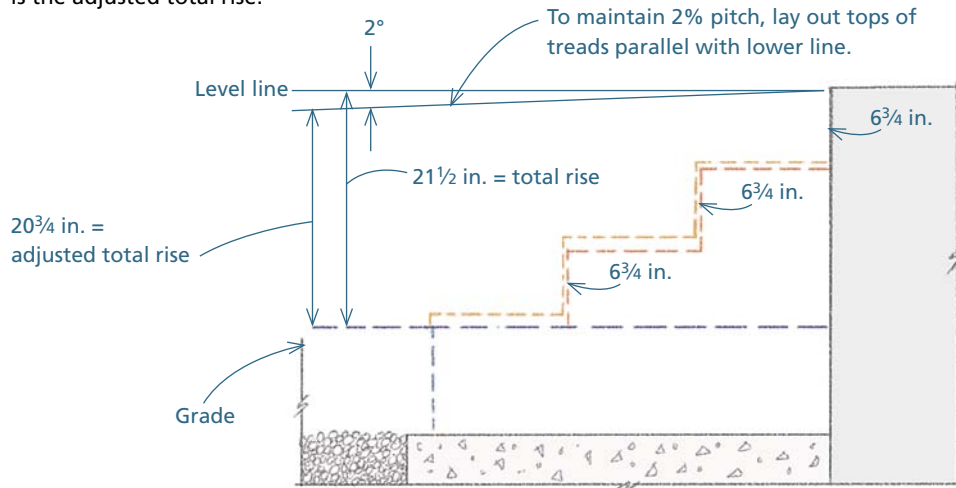

STEP 3 Choose a riser/tread combination

Divide the adjusted total rise by 3 to find the unit rise of each step: $20.75 \div 3 = 6.91$ ($6\frac{15}{16}$ in.). To simplify things, you can make the risers $6\frac{3}{4}$ in. and leave the entire set of stairs step $\frac{1}{2}$ in. higher above the ground. The slight amount of difference in the riser for the first step will be easy to make up when you grade the soil around the stairs. In this example, there's no limit on the overall length of the stairs. To make a gentle slope and to avoid the need to provide a nosing, treads will be 12 in. wide.

STEP 4 Lay out the risers and treads

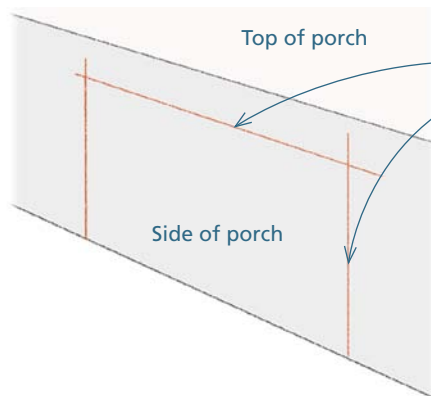

1 Measure $6\frac{3}{4}$ in. down from the top of the porch, and mark a level line at this height on the side of the porch. This line indicates where the top of the form should be. Mark plumb lines representing the sides of the stairs on the side of the porch.

3 Hold the piece perpendicular to the side of the porch, and use a level to mark a level line out from the line on the side of the porch. Set the plywood across a pair of sawhorses to lay out the risers and treads.

2 At one of the plumb lines, set a piece of $\frac{3}{4}$ -in. plywood that's slightly taller and slightly longer than the stairs will be. If necessary, scribe and cut the bottom or side to get a fairly tight fit along the side of the porch and the base.

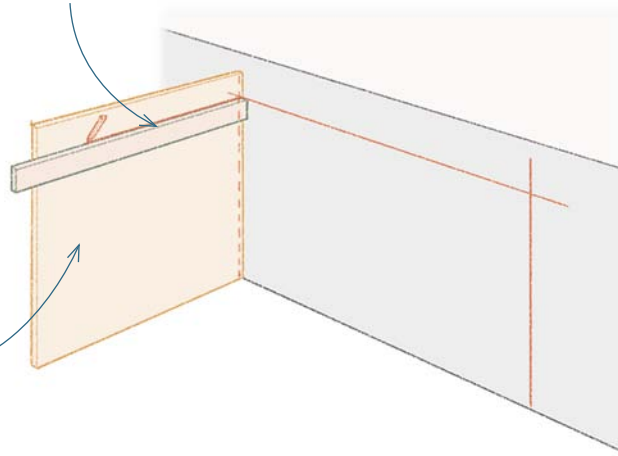

4 Begin by measuring out 36 in. along the level line.

5 From this point, mark a point $\frac{3}{4}$ in. down from the level line. Mark a second line that tapers down from the first line to the $\frac{3}{4}$ -in. mark. This tapered line is the baseline for the layout.

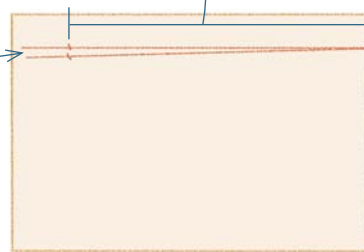

8 Measure and mark 12 in. out from the top riser. Square down from this mark to draw the next riser.

6 Measure and mark 12 in. along the baseline. Use a square to draw a perpendicular line to mark the riser of the top step.

9 Mark a line $13\frac{1}{2}$ in. down from the baseline to lay out the bottom (ground-level) tread. Repeat the process described above to mark the end of the ground-level tread.

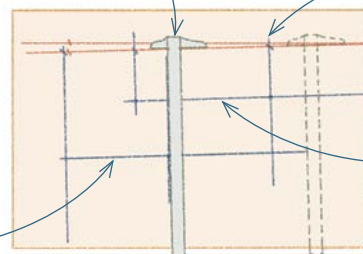

7 Mark a line $6\frac{3}{4}$ in. down from and parallel to the baseline.

10 Use the same technique to lay out the form on the other side of the stairs.

STEP 5 Build the form

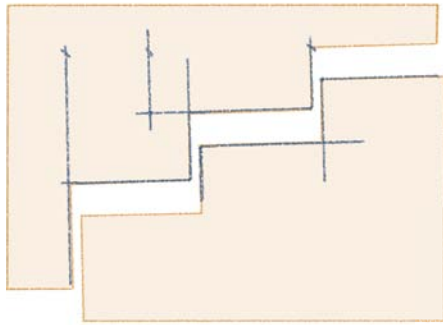

1 Cut out the plywood along the layout.

2 To keep the sides from bulging out from the lateral pressure of the wet concrete during the pour, reinforce the form at key places with 2x4 lumber.

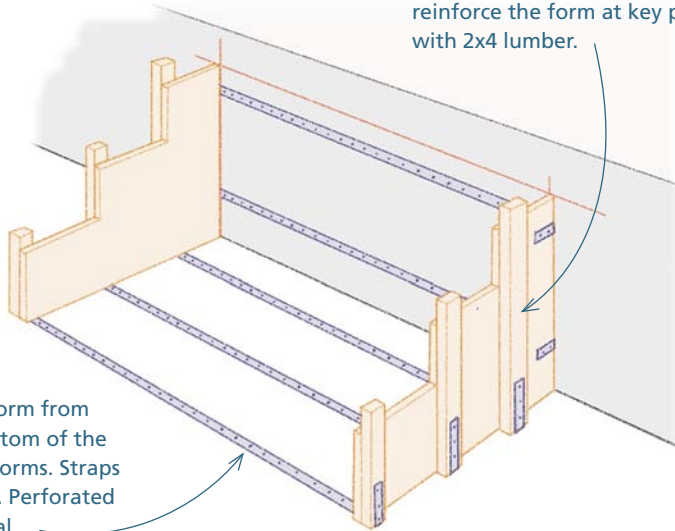

3 To keep the bottom and back of the form from spreading, use steel straps across the bottom of the stairs and up the outside surface of the forms. Straps also can be used at the back of the form. Perforated steel strapping used to hang pipes is ideal.

6 Screw through the riser into the vertical 2x4s on the sides of the form to fasten the riser to the form. On stairs wider than 48 in., you'll also need a center brace running over the risers of the form.

5 Bevel the bottom of the risers at a 30° angle to permit a cement trowel to fit into the inside corner when you pour the concrete.

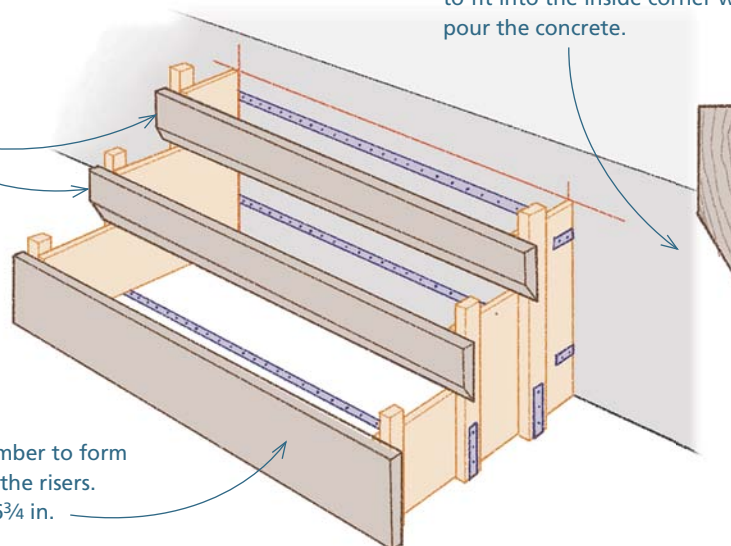

4 Use 2x8 lumber to form the fronts of the risers. Rip these at 6³/₄ in.

STEP 6 Pour and finish the concrete

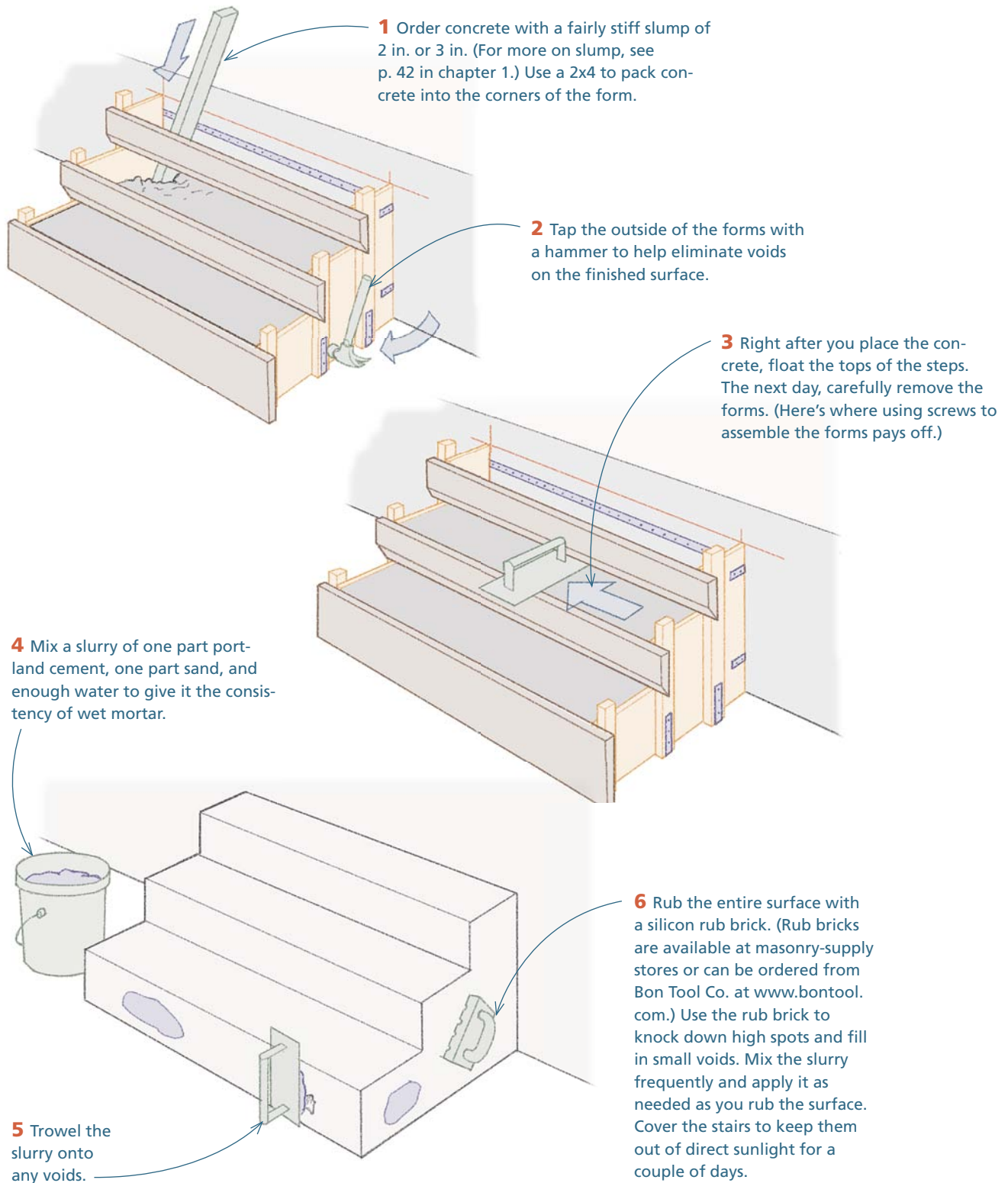

Wood Exterior Stairs

For both practical and aesthetic reasons, wood stairs are often used on the outside of houses. On a practical level, wood stairs are usually less expensive than masonry or concrete stairs. This is especially true when the stairs require more than a few steps. On an aesthetic level, wood stairs often match the rest of the exterior of the house much better than masonry stairs.

Design considerations for wood exterior stairs Wood exterior stairs have to be detailed to help them last. The two most important concerns are moisture content and the fasteners used to tie the stairs together.

When wood absorbs moisture, it swells; when it dries out, it contracts. When a piece of wood dries out on one side and remains moist on the other, the board cups or twists. When a board is anchored along both edges and contracts, it splits. Because of these problems, keeping the moisture content as consistent as possible is a major design priority for wood stairs built outdoors. There are three measures you can take to achieve this goal.

- Pitch the treads so that they shed water.
- Avoid joints that collect water.
- Coat the wood with a water-resistant finish. Manufacturers of treated wood, such as Osmose® and Wolman™, offer wood preservatives that include a water-repellent component. When you build stairs out of treated wood, use one of these to coat all the cuts as you build the stairs. When the stairs are finished, coat them as soon as possible with a water-repellent stain, a clear water repellent, or paint. Whatever coating you use, follow the recommendations of the manufacturer.

The most common chemical for treating wood, alkaline copper quaternary (ACQ), rapidly corrodes common steel. All fasteners in treated wood, therefore, should be hot-dipped galvanized steel, stainless steel, or coated deck screws approved for contact with pressure-treated material.

Laying out wood stringers The layout for wood stringers differs from the layout of masonry and concrete stairs in one important regard. When you lay out brick or concrete stairs, you lay out to the final dimensions of the risers and treads. But when you lay out a notched stringer, you lay out to dimensions that are short of the final dimensions by the thickness of the treads and risers.

In this instance, we're going to build stairs to a deck that's about 5 ft. off the ground. The process can be divided into nine steps.

STEP 1 Choose a method for attaching the stringers to the deck

Stringers can be attached in one of two ways: even with the top of the deck or one step down from the top of the deck. In this example, stringers will be attached one step down. To provide a bearing surface for the stringers, two posts were strategically placed as the deck was built. The same posts extend past the deck and will later serve as newels for the railing system.

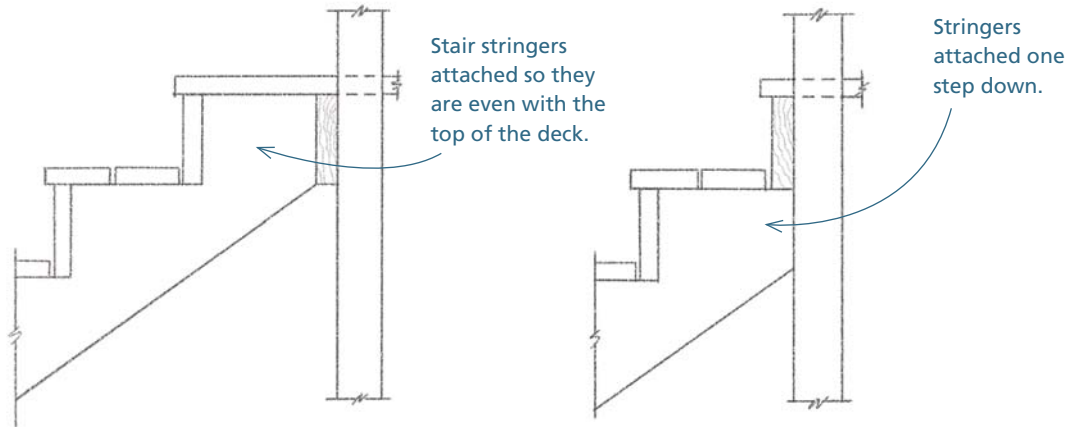

STEP 2 Estimate the total rise

2 Divide that distance by 7 to get an idea of how many risers will be required to get from the ground to the deck: $55.5 \div 7 = 7.93$. Round up and down to whole numbers. In this case, the preliminary estimate is that the stairs will require seven or eight risers. Keep in mind that these are preliminary numbers; the final tally won't be known until after you measure the grade and make the adjustment necessary to shed rainwater.

1 Measure the distance from the ground to the top of the deck. In this example, that distance is $55\frac{1}{2}$ in.

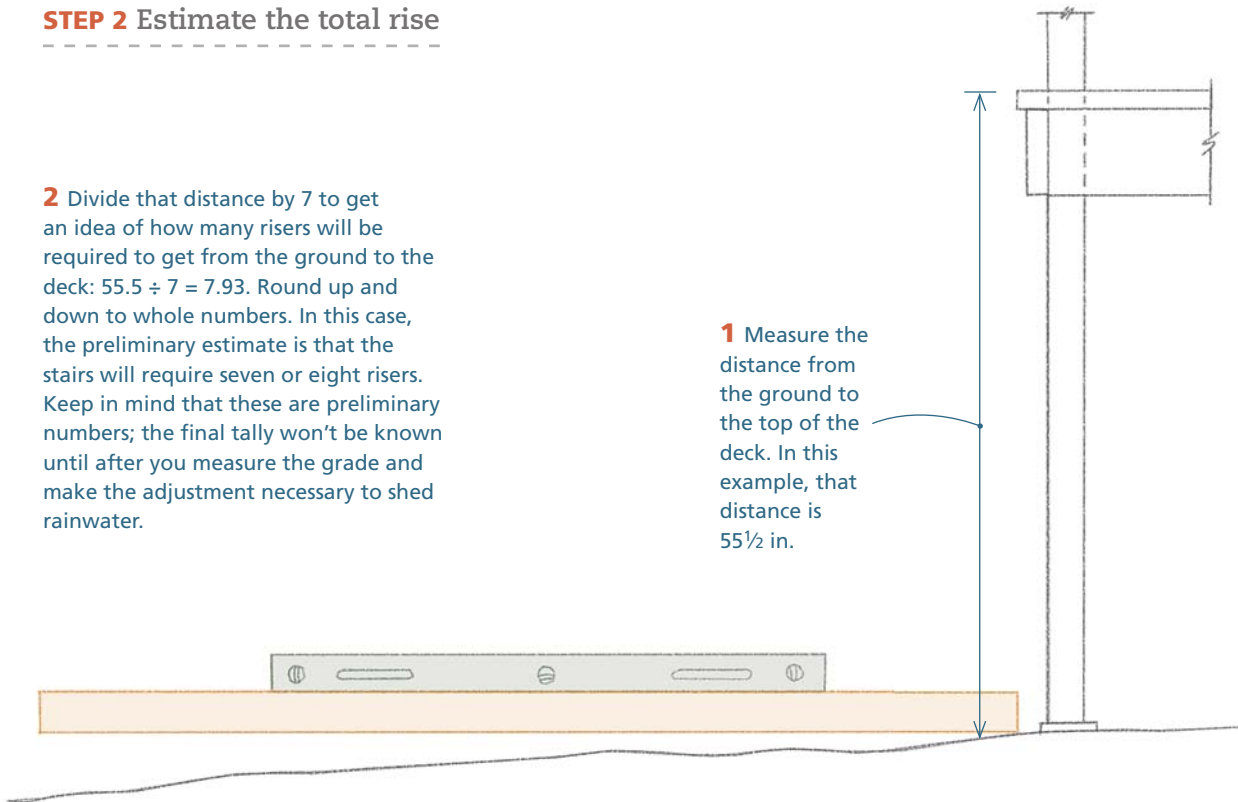

STEP 3 Measure the difference in grade

Before you can measure the difference in grade between the edge of the deck and the point at which the stairs will land, you have to estimate the total run of the stairs. And for that, you'll need an estimate on the size and number of treads.

1 Two deck boards 5½ in. wide will be used for the treads.

2 Treads will be divided by two ¼-in. spaces, so the installed width of the treads will be 11½ in.

4 If you have seven treads, the total run will be 73.5 in. ($7 \times 10.5 = 73.5$). If you have eight treads, the total run will be 84 in. ($8 \times 10.5 = 84$). Measure and mark a straight board at a point that's about midway between these lengths (about 78 in.). Set a level on the board, and hold the assembly so that it spans from the deck edge to the approximate landing point of the stairs.

3 Because a 1-in. nosing is planned, the tread depth will be 10 in.

5 Measure down from the bottom of the board to check the difference in grade. In this case, the grade drops 5 in. over a 78-in. span.

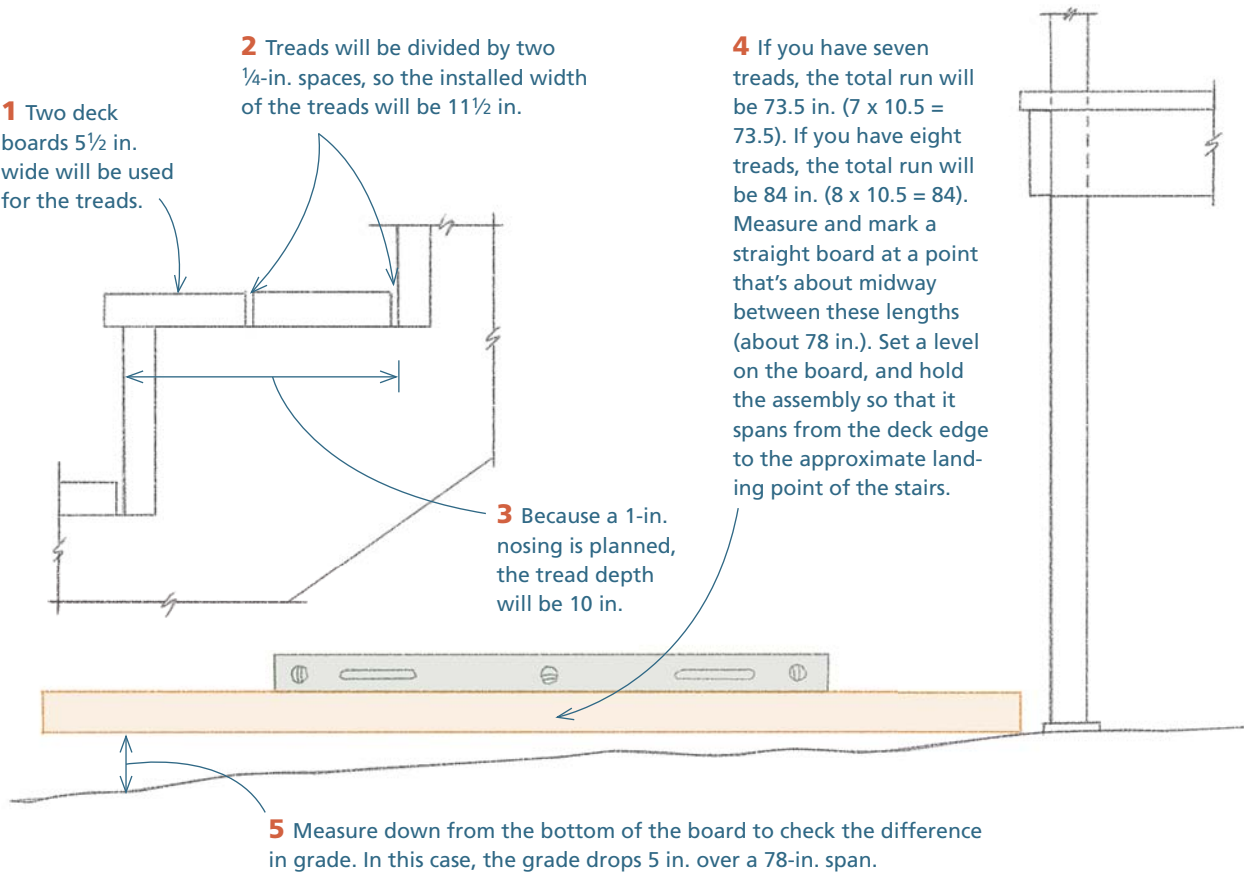

STEP 4 Calculate the adjusted total rise

Add the height at the edge of the deck to the 5 in. of fall in the grade: $55.5 + 5 = 60.5$. This is the total rise. To determine the amount that you need to drop the bottom of the stringer to get the required $\frac{1}{4}$ -in.-per-foot grade on the treads, divide the estimated run, 78 in., by 12, then multiply the result by 0.25 ($78 \div 12 = 6.5$; $6.5 \times 0.25 = 1.625$). Subtract the result from the total rise: $60.5 - 1.625 = 58.875$. The adjusted total rise is 58.875 in.

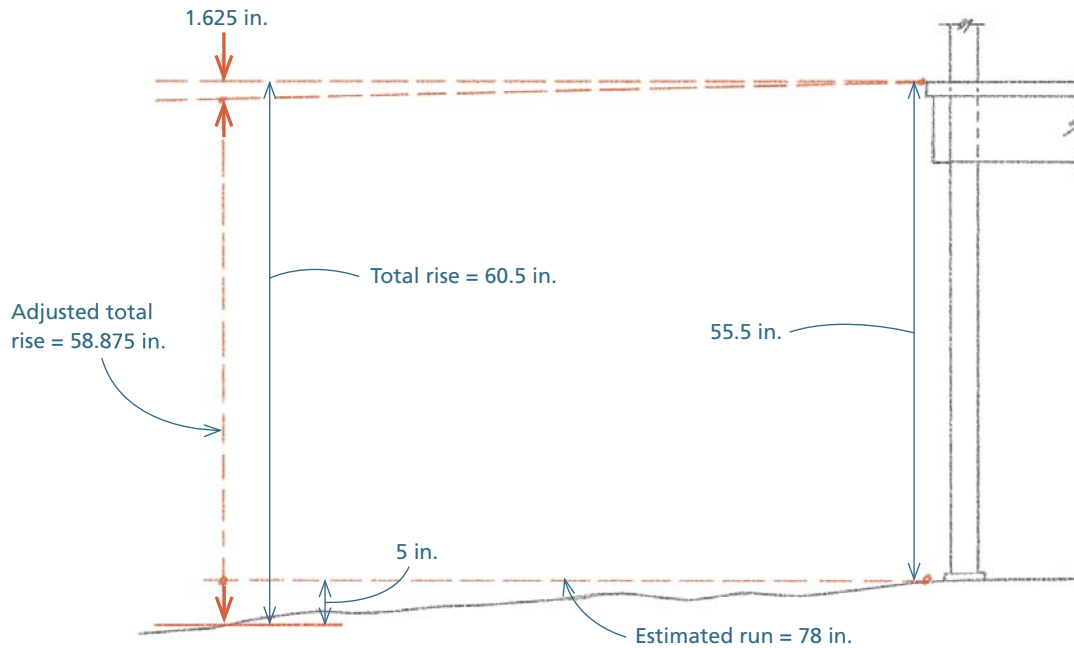

STEP 5 Choose a riser size

Divide the adjusted total rise by seven risers: $58.875 \div 7 = 8.41$. This riser height is too high to meet code. Divide the adjusted total rise by eight risers: $58.875 \div 8 = 7.36$. This riser height is just over the width of a 2x8, which is $7\frac{1}{4}$ in. If you choose a riser height of $7\frac{1}{4}$ in., the total rise of the stairs would be 58 in. ($7.25 \times 8 = 58$). This would mean that the first step up in the finished stairs would be about $\frac{7}{8}$ in. higher than the other steps. This could be easily remedied by building up the grade at the bottom of the stairs.

The final choice for the riser/tread combination for these stairs, therefore, is: 7.25-in. riser/10.5-in. tread. This combination complies with the building code, falls within the limits of the Rule of Proportion ($7.25 + 7.25 + 10.5 = 25$), and ascends at a comfortable 34.6° angle. An added benefit is that you'll save time building the stairs because you won't have to rip material for the risers or treads.

STEP 6 Fabricate a stair jig

You can use a framing square or a stair jig to lay out the risers and treads on the stringers. Here, a stair jig will be used. It takes only about 10 minutes to make one, and it can be used to lay out identical risers and treads quickly. It's also a handy tool for laying out the guardrail. Plywood is the best material to use for the jig.

3 Connect the marks with a straight line.

4 Draw a second line parallel to and about 2 in. above the first line.

5 Cut the piece off at this second line.

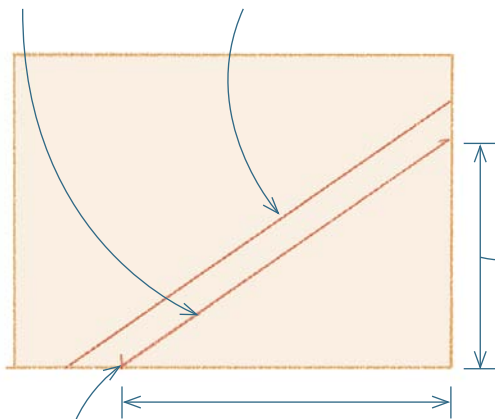

1 Measure and mark 7 1/4 in. up from the corner.

2 Measure and mark 10 1/2 in. out from the same corner.

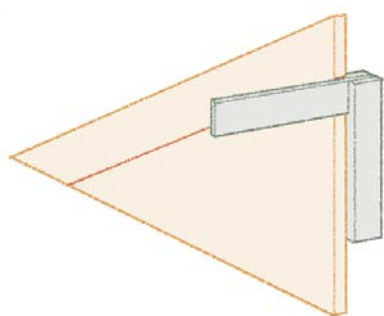
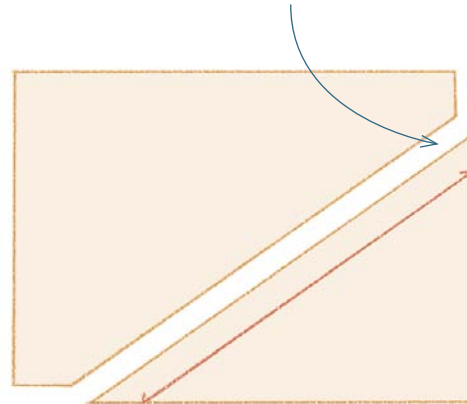

6 At the first line, square across the edges at both ends. Use the marks on the edges to transfer the first line to the back side of the piece.

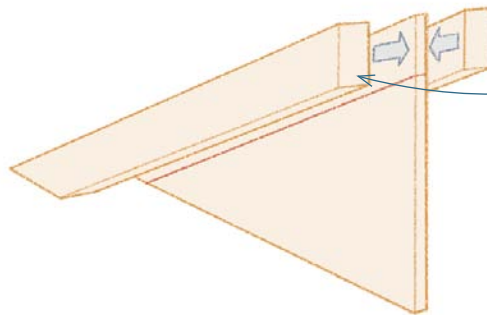

7 Attach fences on the lines of both sides of the piece. The fences should be in the exact same position on both sides of the jig.

STEP 7 Divide the stringer into eight equal parts

When laying out a stringer, a small error repeated numerous times can add up to a significant error. To avoid making a cumulative error in the layout, start with the overall layout along the top of the stringer and then divide that layout into eight equal parts. To calculate the total layout along the top of the stringer, start with the total rise for this stairway (58 in., from step 5). Next, find the total run for an equal number of stairs, with the chosen tread depth: $8 \times 10.5 = 84$ in.

Find the hypotenuse of a right triangle with an altitude of 58 and a base of 84. The formula for this calculation is: $H = \sqrt{A^2 + B^2}$, where H is the hypotenuse, A is the altitude, and B is the base. Plugging in the numbers, the math looks like this:

$$H = \sqrt{58^2 + 84^2}$$

$$H = \sqrt{10,420}$$

$$H = 102.0784$$

This hypotenuse is the length of the overall layout along the top edge of the stringer. Divide the overall length into eight equal increments, each of which will represent the hypotenuse of an individual riser/tread combination: $(102.0784 \div 8 = 12.759799)$.

Methods for marking these increments precisely on the stringer are discussed in "Three Ways to Divide a Space into Equal Increments" on p. 460.

1 For these stairs, the stringers will be cut from three treated 2x12s. Crown one of the 2x12s, and lay out the equal increments along the top edge.

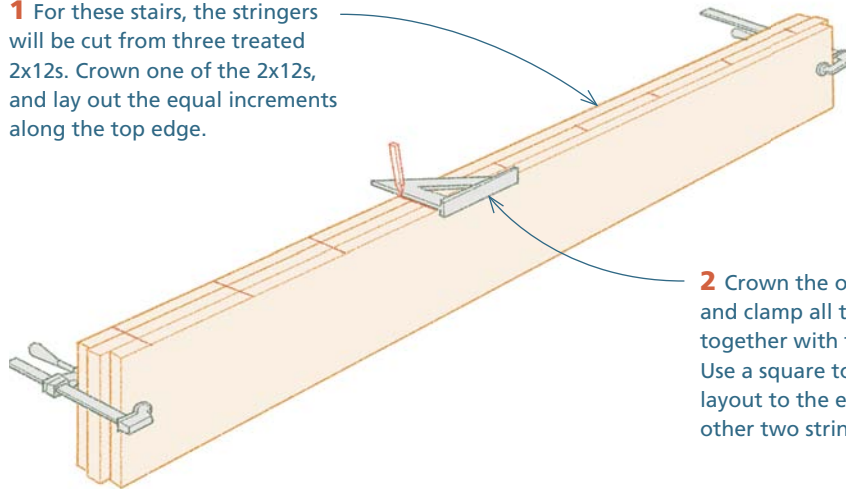

2 Crown the other boards, and clamp all three pieces together with the crown up. Use a square to transfer the layout to the edges of the other two stringers.

(continued on p. 462)

Three Ways to Divide a Space into Equal Increments

There are three ways to lay out equal increments within a given space: use the slant rule trick; use a divider; or use the add-on feature of your calculator.

Method 1: Using the slant rule trick

The slant rule trick, which is discussed on p. 265, has the advantage of simplicity. However, it requires a broad, flat surface and the snapping of numerous chalklines. While it works great for laying out shingle or siding courses directly on the sheathing of a house, it's not the best technique for laying out equal increments on a lineal surface. For stair stringers or balustrades, use one of the following techniques.

Method 2: Using a divider

The divider is a simple A-shaped tool that can be used for scribing irregular shapes, drawing arcs and circles, transferring measurements, and dividing a given distance into equal increments. For dividing a stair stringer into equal increments, you'll need a divider at least 12 in. long. The best size for stair stringers is an 18-in. divider. One source for a divider this size is Highland Woodworking (www.highlandwoodworking.com). For dividing a section of a balustrade into equal increments, you can usually use an 8-in. or smaller divider.

In this example, the overall layout on a stair stringer is 188.468 in., and you need to divide it into 15 equal increments. Find the size of the increments:
 $188.468 \div 15 = 12.57$ or $12\frac{9}{16}$ in.

1 Make two marks $12\frac{9}{16}$ in. apart on a piece of wood, and set the dividers to the marks.

2 Mark the beginning and ending points of the overall layout on the stringer.

3 Use the divider to mark a single increment. The remaining space must now be divided into 14 equal increments.

4 Divide the remaining space, which is about $175\frac{7}{8}$ in. long, precisely in half, using the technique described on p. 73. Once this space is divided into equal parts about $87\frac{15}{16}$ in. long, transfer the length of one of the halves to a strip of wood.

5 Use the divider to mark off seven equal increments on the strip of wood. Starting at one mark, march the divider end-over-end up the strip. If it doesn't land on the other mark, use the threaded knob to minutely adjust the spread of the legs and try again. Repeat the process until the divider lands evenly at the second mark. When it does, walk the divider up the layout one last time, marking each increment as you go.

6 Transfer the layout from the strip of wood to the two equal spaces on the stringer.

Method 3: Using the add-on feature of your calculator

Although using a divider to lay out equal increments is reasonably fast, you can save time using the add-on feature of your calculator. The add-on feature adds the same number over and over again to an ever-growing total. If you start with 3, for example, the totals would be 3, 6, 9, 12, etc. With most handheld calculators, you would start this process by entering $3 + =$. Doing this brings up the number 6. Now each time you enter $=$, the calculator adds 3 to the last total. Some handheld calculators require you to start by entering $3 + 3 =$. After 6 appears, press $=$ again and the add-on feature begins.

To see how this would work for laying out evenly spaced balusters along a rail, let's use the example of a section of a balustrade. In this example, the space is 92.25 in. long, and we want to divide it into 21 equal spaces.

Step 1: Divide the overall length by the number of increments: $92.25 \div 21 = 4.3928571$. With most calculators, you can now enter $+ =$ and the number 8.785714286 will appear. You are now in the add-on mode and can enter $=$ again to get the next total. (With some calculators, you have to add 4.3928571 to 4.3928571 to start the process.)

Step 2: Leave the numbers in the calculator carried out to as many decimals as your calculator displays.

Doing this avoids the cumulative error that might occur from rounding the first number and then adding the rounded number 21 times.

Step 3: Each time you enter $=$ and a new total appears, write the number down. Round the numbers to two decimal places as you write them down. The first two numbers in this example, for instance, could be written down as 4.39 and 8.79.

Step 4: After you've written down all 21 numbers, convert them from decimals to fractions (see p. 500).

Step 5: Use the fractional dimensions to pull the layout from a single starting point.

Avoiding the decimal to fraction conversions

There are two ways to avoid the decimal to fraction conversions. The first is to use a construction calculator, which adds in fractions of an inch. The second is to use metric units. Begin by converting the increment from inches to centimeters: $4.3928571 \text{ in.} \times 2.54 = 11.157857 \text{ cm}$. Starting with this number, use the add-on feature to find the cumulative totals for the layout. Round the results to one decimal place, and use a metric tape to lay out the rounded dimensions from a single starting point.

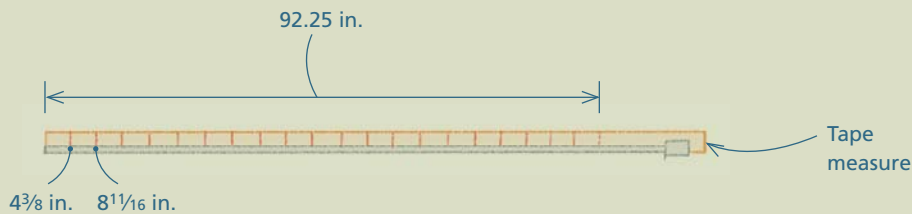

STEP 8 Mark the risers and treads on the stringers

1 With the fence on the top edge of the board, center the stair jig between the marks.



2 Scribe along both edges to mark the riser and tread. Slide the jig to the next marks and repeat the process. As you work your way up the stringer, keep the jig centered between the marks to avoid cumulative error.

STEP 9 Lay out the top and bottom stairs

To get the top and bottom of the stairs right, visualize exactly how the stairs will be installed and finished. In this stairway, the bottom of the stringer will rest on a concrete pad. At the top, the outside stringers will bear against the posts installed on the deck. The center stringer will bear against a header attached to the front of the posts. At both the top and the bottom, the riser/tread layout has to be altered from the combinations marked on the stringers. All the steps in between will be cut exactly as they are now laid out on the stringers.

1 Starting at the second riser from the top, draw in the top two risers and treads. At the top riser/tread combination, superimpose the location of the decking, rim joist, and post. On this deck the rim joist and decking work well with the stairs. Since the same material is used for the decking and the stair treads, they are the same thickness. The rim joist is a 2x8, which is the same height and thickness as the risers.

2 At the bottom, draw in the first riser and tread.

3 Measure down 7¼ in. from the top of the drawn-in tread to establish the height of the concrete and the level cut at the bottom of the stringer. Doing this makes the riser height 1 in. shorter than the riser height for all the other steps, as marked on the stringer. The 1-in. difference will be made up when the tread is added to the first step.

The two outside stringers fit just under the rim joist and bear against the posts. The cut for these stringers is at the front edge of the post, which is in line with the uppermost riser that you marked on the stringer with the stair jig.

The center stringer has to be cut differently because it will bear on a header joist that's fastened to the face of the posts. Draw in the location of the header joist on the front of the post, and mark the cutline for the stringer at the front face of the header.

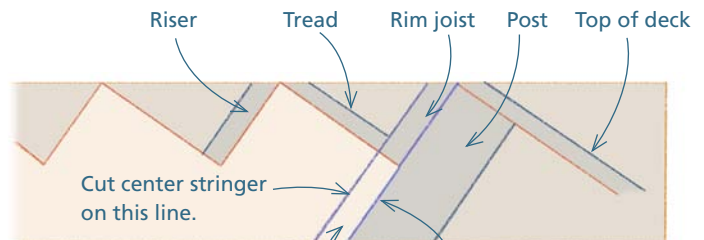

Top of stair

Header joist

Cut outside stringers on this line.

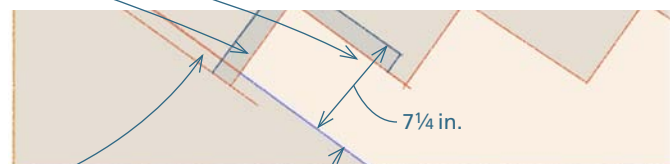

Bottom of stair

Cut this line.

● CUT AND INSTALL THE STAIRS

The process of cutting and installing these stairs can be divided into six steps.

STEP 1 Cut the stringers

1 Cut the stringers along the layout lines. Avoid overcutting at the inside corner formed by the riser and the tread, which looks sloppy and weakens the stringer.

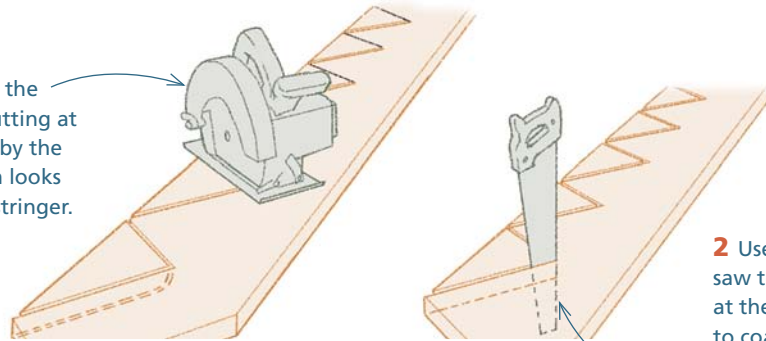

2 Use a jigsaw or a hand-saw to complete the cuts at the corners. Don't forget to coat the cuts with stain, clear water repellent, or an approved primer.

STEP 2 Dig the footing

Hold the stringer in place to mark the footing.

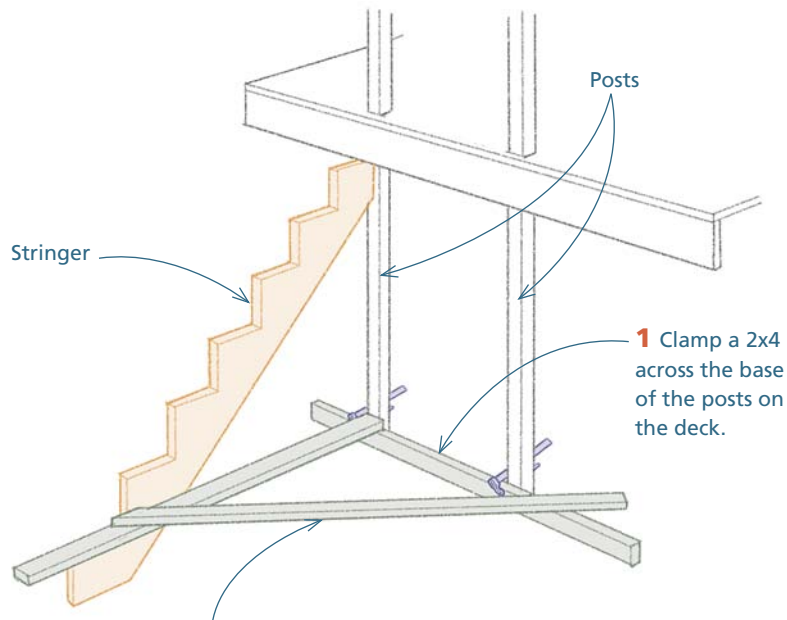

2 Convert a 3-ft./4-ft./5-ft. right triangle into inches. Then, enlarge this triangle by a factor of 1.5. Use these dimensions to make a large square with the side extended to square up the stringer.

$$1.5 \times 36 = 54$$

$$1.5 \times 48 = 72$$

$$1.5 \times 60 = 90$$

STEP 2 Dig the footing (continued)

3 After marking the landing point for the stringers, dig the footing. The top of the footing will form a ground-level landing exactly $7\frac{1}{4}$ in. down from the top of the first tread.

4 To anchor the stairs to the footing, the outside stringers will be bolted to the posts that will be used for the guardrail. These posts will be embedded in the concrete, so make the footing several inches wider than the stairs.

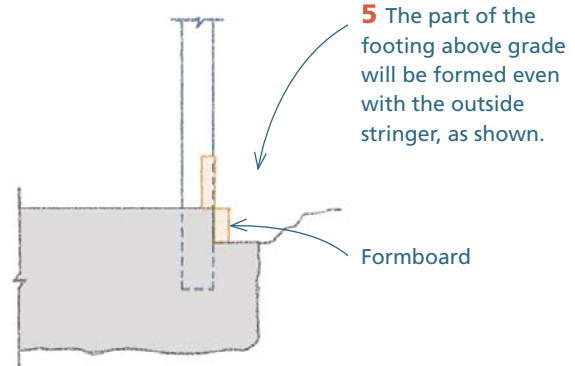
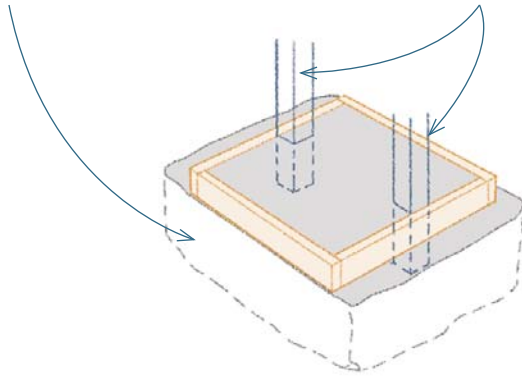

STEP 3 Install the stringers

1 Cut and install a header joist. Rip it to a bevel that equals the pitch of the stairs (34.6°). The width of the header joist should be equal to the bearing surface of the center stringer.

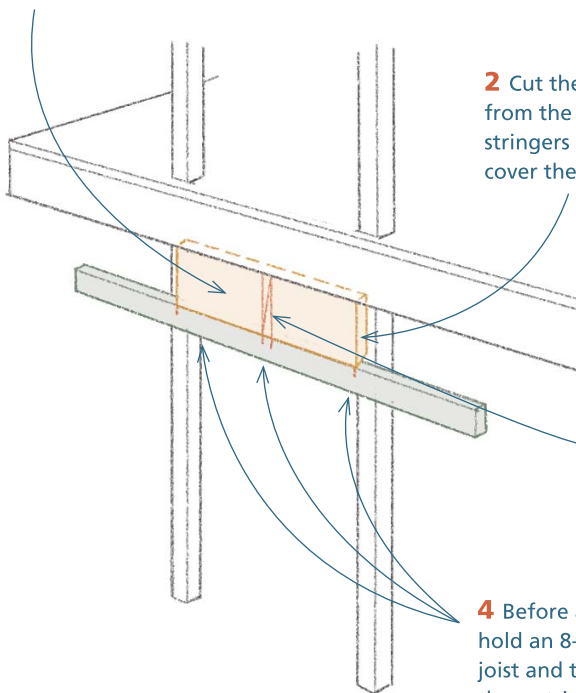

2 Cut the header joist so that it fits $1\frac{1}{2}$ in. in from the outside edges of the posts. The two stringers on the outside will then lap over and cover the ends of the header joist.

3 Lay out the location of the center stringer on the header joist.

4 Before attaching the stringers, hold an 8-ft. 2x4 under the header joist and transfer the locations of all three stringers to the 2x4.

7 Check the treads to make sure that they have the requisite $\frac{1}{4}$ -in. pitch, and check for level along the length of the 2x4. Adjust as necessary with scraps and shims until the stringers are in the right position.

8 Drive stakes in the ground, and brace the stringers in this position.

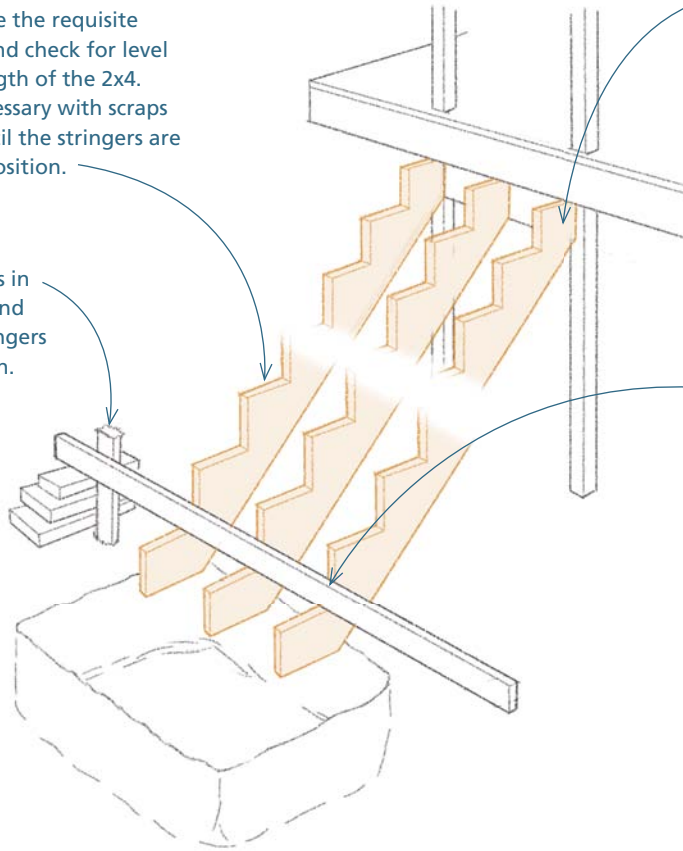

5 Attach the tops of the three stringers to the deck. They should fit tight to the underside of the rim joist of the deck. The two outside stringers can be fastened to both the rim joist and to the ends of the header joist. The center stringer should be fastened to the header joist at the layout mark.

6 At the bottom, screw the 2x4 across the bottoms of the second riser, making sure the stringers line up with the layout marks on the 2x4. Use scraps to prop up the ends of the 2x4. Use the 3-4-5 square to adjust the stringers square to the deck.

STEP 4 Form the landing

Form the landing so that the concrete slopes at the same 2° ($\frac{1}{4}$ in. in 12 in.) as the treads of the stringer. The landing can be any size, but this one is $11\frac{1}{2}$ in. wide, the same size as the stair treads. Make the outside of the form 13 in. from the vertical cut on the stringer. After the riser and the nosing of the tread above are added, the tread depth of the landing will be reduced to $10\frac{1}{2}$ in.—the same as all the treads above.

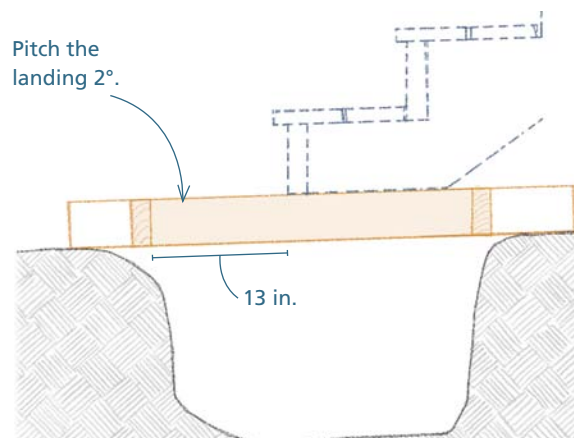

STEP 5 Install the posts

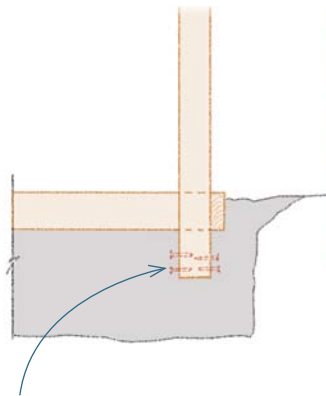

1 The posts should extend at least 8 in. into the concrete.

2 Cut a notch in the posts, and fit them over the stringer so that the outside of the post is even with the outside of the stringer. This places them in line with the posts at the top of the stringer. (See "Cutting Notches in Newels" on p. 491.)

3 In the area that will be embedded in the concrete, drive several large screws on each side of the post, leaving about 1½ in. of the screws sticking out of the surface. These will help anchor the posts in the concrete.

Make sure you have enough of the post above the stringer. The post has to be tall enough to accept the rail at a code-approved height. For ways to determine the required height, see "Measure the baluster lengths" on p. 475.

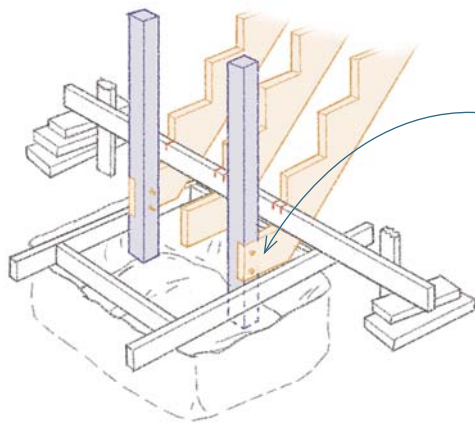

4 After fitting the post over the stringer, clamp it plumb in the plane of the stringer. Drill and bolt the post to the stringer. Brace the post side-to-side.

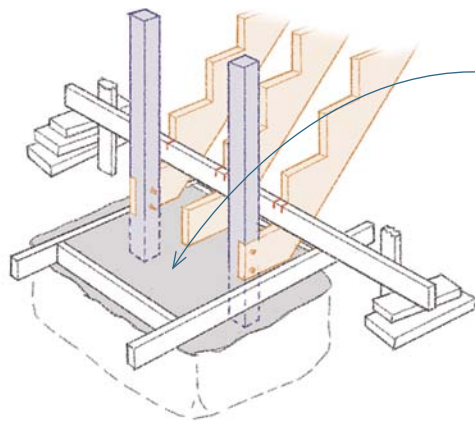

5 Mix up concrete for the footing. Pour it up to the top of the form, then use a brush to give it a textured, nonslip finish.

TOP TIP

Add a Step and Keep the Risers and Treads Even

.....
When the stringer will be installed one riser height down from the top of the deck, include an extra step, representing the final riser up to the deck (or top floor), in the layout. This step will not be part of the stringer, but it's helpful to draw it in detail. Also, when you calculate the overall run, always use an equal number of risers and treads. If these aren't the same, the overall run will be wrong.
.....

STEP 6 Install the risers and the treads

Let the concrete cure for 72 hours before installing the risers and treads.

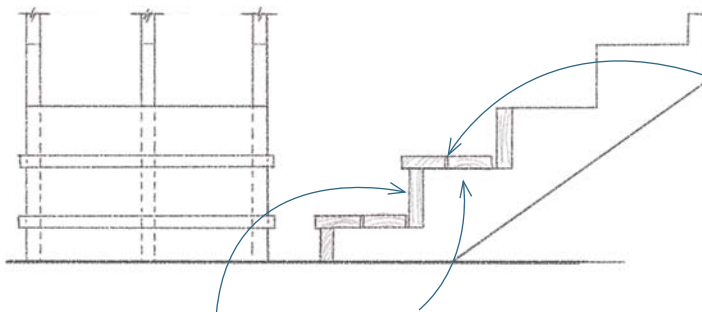

1 Install the risers first. Square-cut the 2x8s to the width of the stairs, and screw them to the vertical cuts on the risers.

2 Cut the treads 2 in. longer than the risers. Install the first tread board $\frac{1}{4}$ in. out from the riser.

3 Install the second with a $\frac{1}{4}$ -in. space between it and the first tread board. Leave a 1-in. overlap on each side. Use $2\frac{1}{2}$ -in. deck screws for the risers and 2-in. deck screws for the treads. Pre-drill to avoid splitting the wood.

Exterior Balustrades

The balustrade on exterior stairs, porches, and decks is essential for safety as well as appearance. Although exterior balustrades can be made from masonry or metal, wood balustrades are more common for residential construction. In this section, we'll examine the construction of a wood balustrade built along the perimeter of a deck and the sides of a set of stairs. This balustrade will have a space beneath the lower rail, which is convenient for sweeping snow, leaves, and other debris off the deck.

TOP TIP

A Graspable Handrail inside a Treated Guardrail

For both practical and aesthetic reasons, the rails on the balustrades of decks are often made with 2x4 or 2x6 lumber. This is fine for guardrails but is not always acceptable for the handrail along the stairs. If your inspector does not accept 2x handrails, you can build guardrails out of treated lumber and install graspable handrails inside the guardrails along the stairs.

● LAYING OUT A BALUSTRADE ALONG LEVEL SECTIONS

The process of laying out a horizontal balustrade that complies with the building code can be divided into four steps.

STEP 1 Install the posts

2 If you build a deck with a cantilevered frame, the posts that support the deck are set in from the outside edge and can't be used for the balustrade. In these cases, use hot-dipped galvanized bolts to anchor the posts to the frame. In some cases, the building inspector might also require galvanized steel anchors, such as Simpson Strong-Tie®'s DTT22.

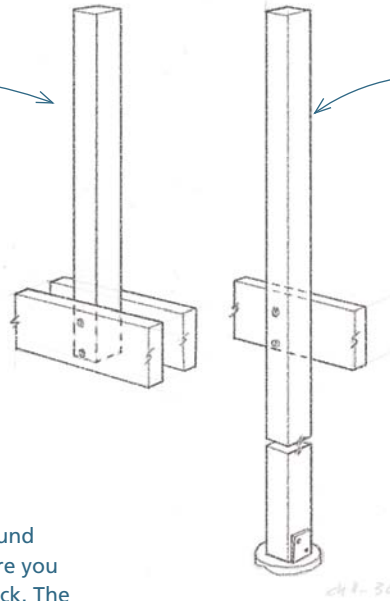

1 Posts that support a deck or porch also can support the balustrade. At the stairway, the same post can support a section of the deck, a stringer, a horizontal section of the balustrade, and a sloping section of the balustrade. On covered porches, the posts that support the roof can also support the balustrade.

Whether the posts extend from the ground up or begin at the deck frame, make sure you extend them high enough above the deck. The simplest way to avoid a mistake is to leave them several inches long at this stage and cut them down to precise dimensions later. To get an idea of how high to leave the posts, see step 4.

STEP 2 Mark the rails

At each section, place a rail on the deck so that it runs past the posts at both ends.

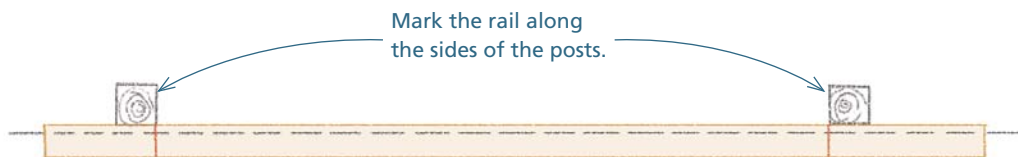

STEP 3 Measure the baluster lengths

The top of the balustrade in this example will be 38 in. above the deck. The space under the bottom rail will be 3½ in.

3 The distance between the top of the lower rail and the bottom of the upper rail is the length of the balusters (31½ in. in this example).

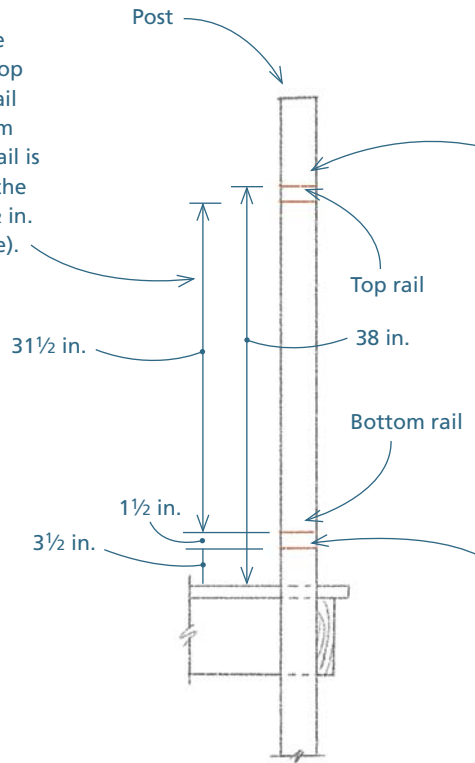

2 At the top, mark the post at 38 in. Measure down the thickness of the upper rail (1½ in. in this example). Use a square to draw level lines at these four points.

1 At the bottom, mark the post 3½ in. up from the deck. Measure up the thickness of the lower rail (1½ in. in this example) and mark the post.

STEP 4 Lay out the baluster locations on the lower rails

All the spaces between balusters in each section of railing will be the same size, including the distance from each post to the nearest baluster. Any slight difference in spacing from section to section shouldn't be noticeable. Spaces should be as large as possible while still meeting code (4 in.).

1 On the lower rail, mark the thickness of a baluster (1½ in. in this example) to the outside of one of the marks on the rail. The distance from this mark to the far mark on the rail is the overall length of the layout (the distance between the posts plus the thickness of one baluster).

In this example, the overall length of the layout is 70⅝ in. Each increment in the layout should be equal to one baluster and one space. Since one baluster (1½ in.) plus one space (4 in.) equals 5½ in., the maximum size of an increment is 5½ in. Divide the overall length by 5.5 to find the number of increments: $70.625 \div 5.5 = 12.84$. Rounding up to the nearest whole number indicates that the space should be divided into 13 increments.

2 Divide 70.625 by 13 to find the size of the increment: $70.625 \div 13 = 5.4326923$. Use one of the techniques described in "Three Ways to Divide a Space into Equal Increments" on p. 460 to lay out the baluster locations.

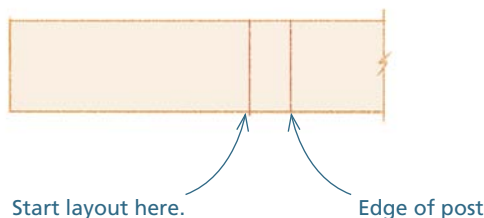
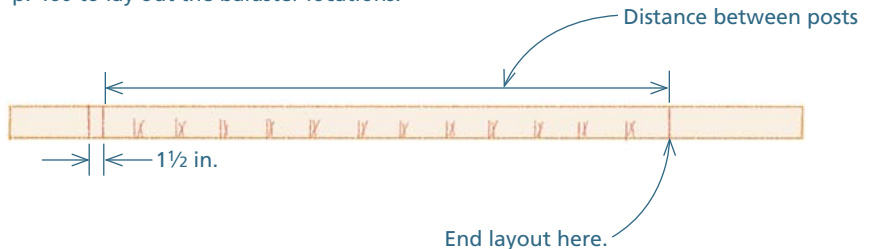

3 Start the layout at the mark that's one baluster width beyond the post-to-post marks and set the layout ahead.

CUT, ASSEMBLE, AND INSTALL THE HORIZONTAL BALUSTRADE SECTIONS

In this example, the top rail on the deck goes over a center post and abuts the corner posts. The lower rail is divided into two sections, one on each side of the center post. The process of cutting, assembling, and installing the balustrade can be divided into seven steps.

STEP 1 Check the posts

Use a level to check that posts are reasonably plumb in the plane of the balustrade. If they're slightly out of plumb, they usually flex enough to allow you to push or pull them into place.

1 If posts need persuading, wedge a brace that extends from the base of the neighboring post to the top of the out-of-plumb post. Push down on the brace until the post is plumb.

2 To pull a post into plumb, attach a hinged brace and push down at the hinge. Attach braces to hold the posts plumb while you mark them at the correct height.

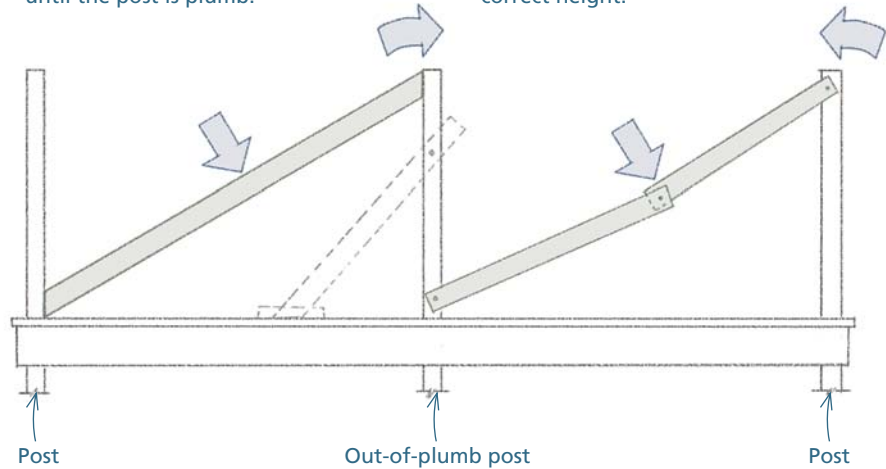

STEP 2 Mark and cut the posts

4 Pull a line from corner post to corner post at this height, and mark the center post at the height of the line. This is the height at which the center post should be cut. (Laying out the post this way, rather than simply measuring 36½ in. up from the deck, ensures that dips or rises in the deck won't be transferred to the top of the rail.)

2 Measure and mark the distance that you want the post to extend above the rail (2 in. in this example). This is the height at which the corner posts should be cut.

3 Measure and mark 1½ in. down from the 38-in. marks on the corner posts to indicate the height of the bottom of the upper rail.

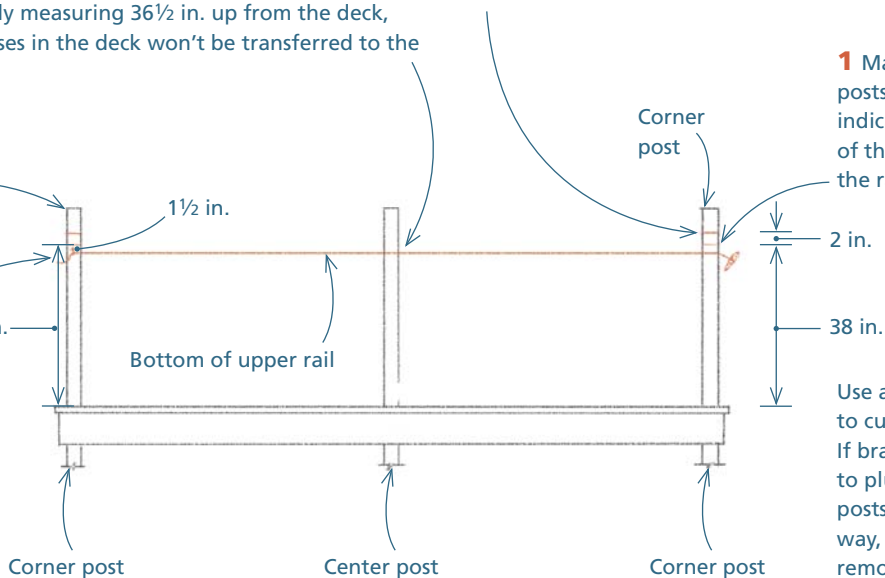

1 Mark the corner posts at 38 in. to indicate the height of the top of the rail.

Use a circular saw to cut the posts. If braces used to plumb the posts are in the way, temporarily remove them.

SAFETY FIRST

Cutting Posts the Safe Way

At the end of a cut on a standing post, the section above the cut suddenly comes down on the spinning sawblade. Usually, the sawblade screeches and sends the waste flying. Worse, the dropped piece sometimes causes the saw to kick back.



1 To avoid this dangerous situation, set the depth of your saw so that it leaves about a 1-in.-square piece of wood in the center of the post.

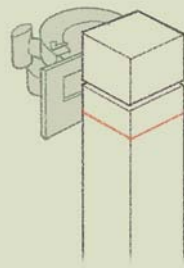

2 Cut to the layout line with a circular saw.

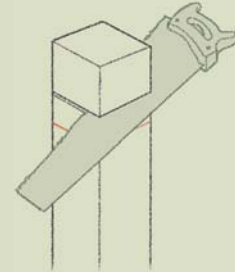

3 Finish the cut with a handsaw.

STEP 3 Cut and fit the rails

Re-plumb the posts, if necessary.

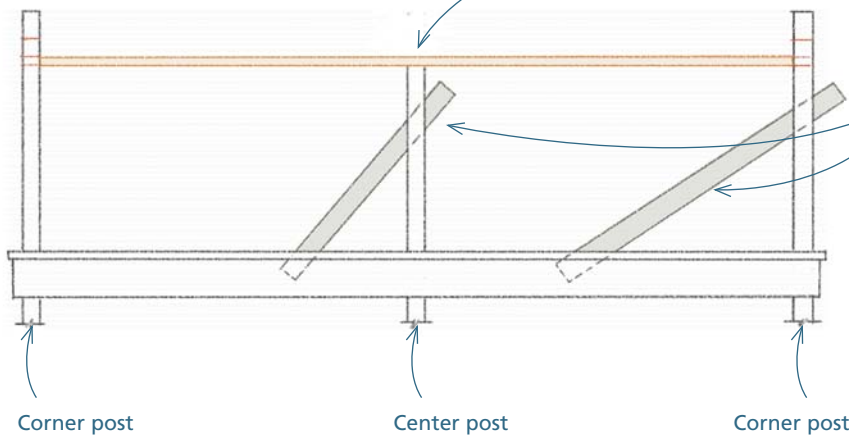

2 Hold the top rail in place and mark it to length. After cutting it to fit between the two corner posts, set it in place and mark the location of the center post.

1 Once you get a post plumb, attach a brace on the outside face to hold it plumb. Make sure the brace is out of the way so you'll be able to install the balustrade sections. The bottom rail has already been marked to length. Double-check the marks and then cut it to length.

STEP 4 Transfer the baluster locations to the top rail

Set the rails side-by-side and use a square to transfer the baluster locations from the bottom rail to the top rail.

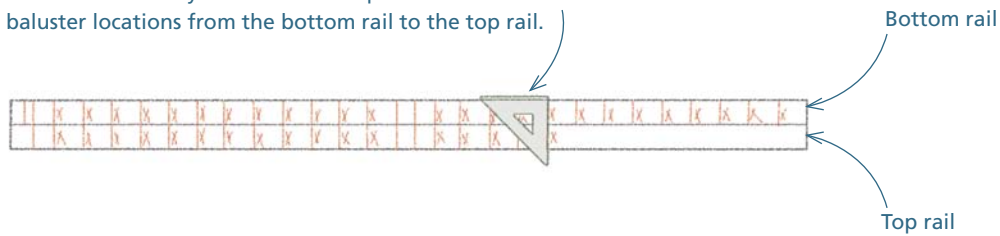

STEP 5 Cut the balusters

The length of the balusters has already been established at 31½ in. (See “Measure the baluster lengths” on p. 469.) Measure and cut one baluster at this length.

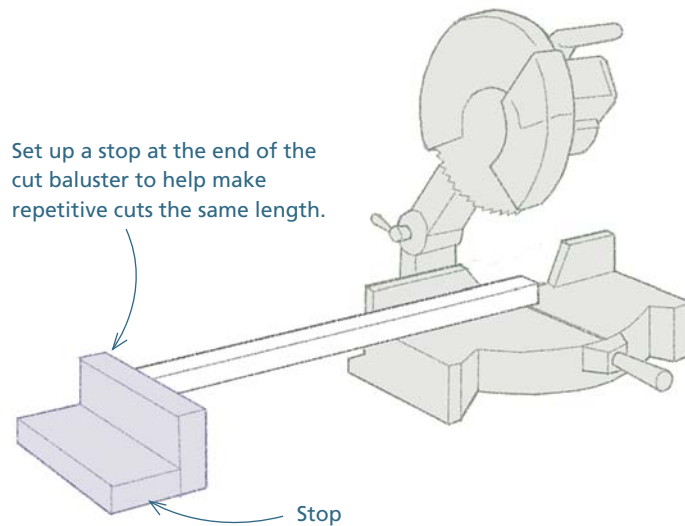

STEP 6 Assemble the section of the balustrade

The balustrade described in this section has no exposed fasteners on the top of the upper rail. If you want to simplify the job and you don't mind seeing the fasteners, you can screw or nail through the top of the upper rail into the balusters. In this design, the balusters are attached to a ½-in. fillet that is then inserted in a dado plowed in the underside of the top rail.

1 Use a router to cut a dado in the underside of the rail. Center the dado, and make it ½ in. deep by 1½ in. wide.

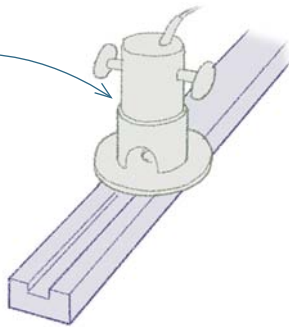

2 Rip a ½-in. by 1½-in. fillet that fits in the dado.

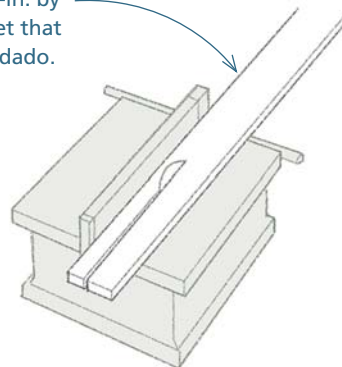

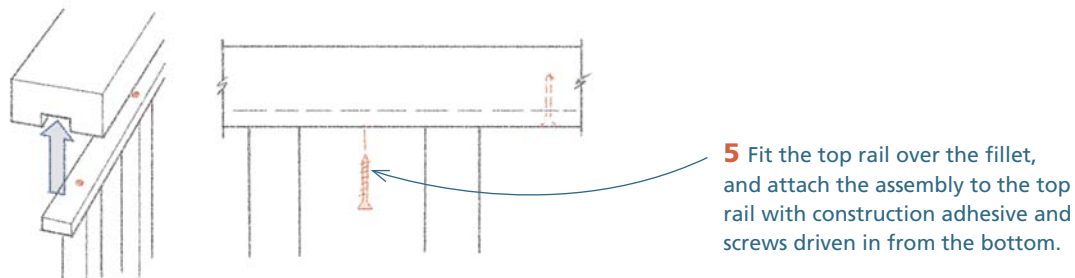
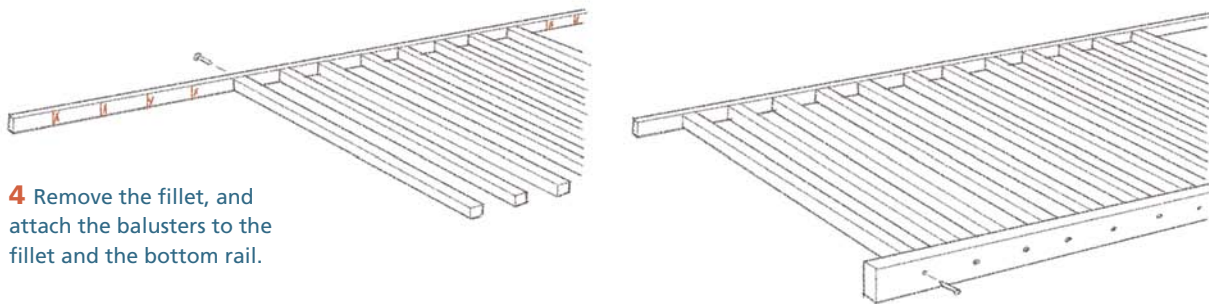
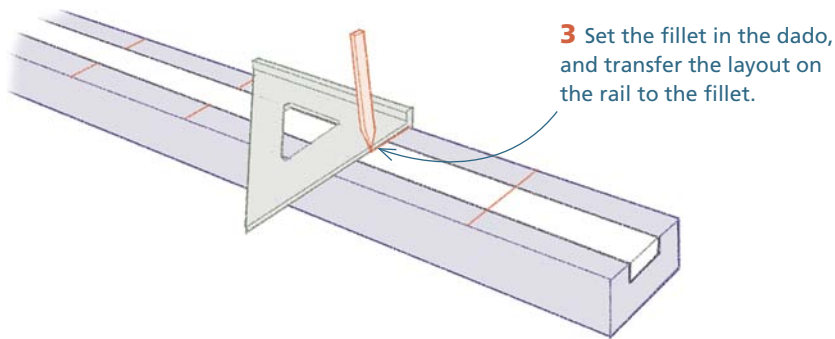

STEP 7 Install the section of the balustrade

1 You can use 2x4 blocks set on edge to hold the section at the desired height as you install it.

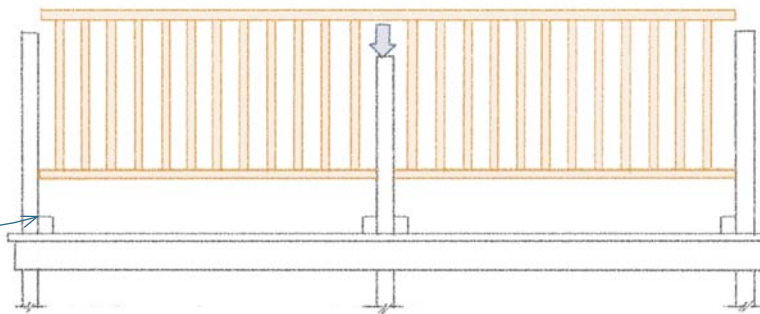

2 To attach the balustrade to the posts, predrill and drive 16d galvanized finish nails through the sides of the rails. Set the heads below the surface, and plan on filling the recess before you stain or paint the rail.

● LAYING OUT A BALUSTRADE ALONG SLOPED SECTIONS

The process for laying out a code-complying balustrade along a set of stairs can be divided into five steps.

STEP 1 Install the posts and mark the rails

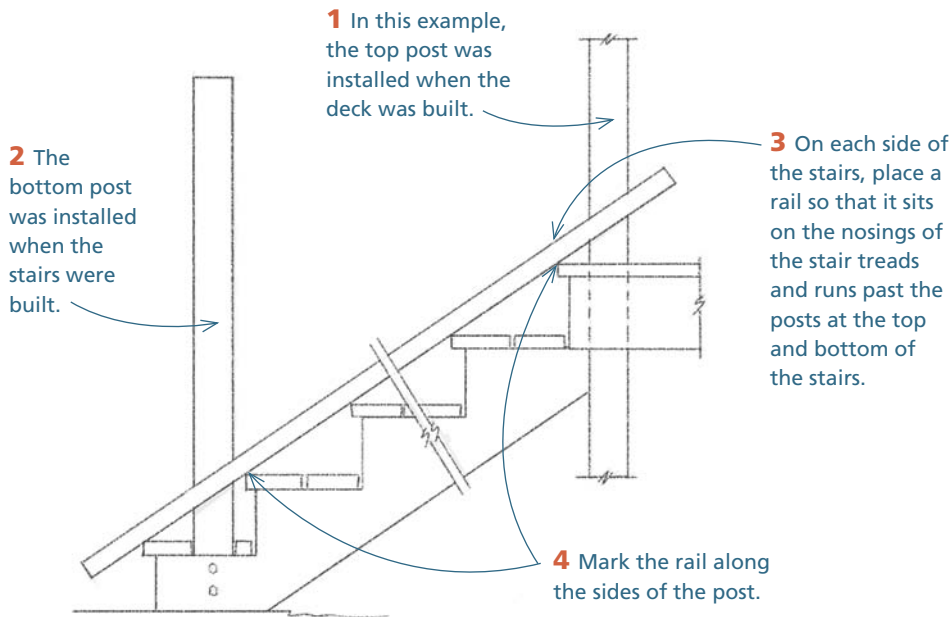

STEP 2 Check the triangular space below the rail

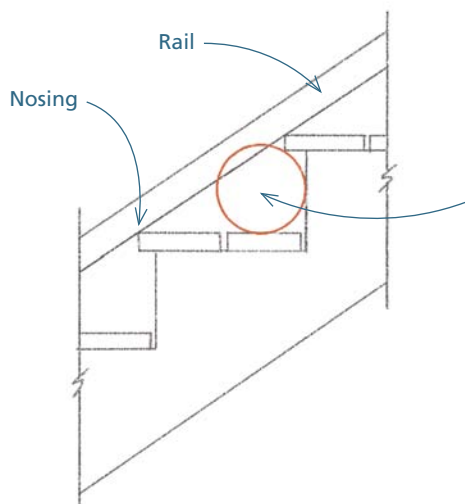

With the rail resting on the nosings, check the triangular section formed by the riser, the tread, and the rail. To meet code, this space must not permit a 6-in. sphere to pass through. To check, set a divider to 3 in. and draw a 6-in. circle on a scrap of plywood. Cut out the circle with a jigsaw. Hold the disk in the corner formed by the riser and tread, and mark the rail along the circumference of the disk. The distance from the bottom edge of the rail to the top of the arc is the maximum distance you can install the rail above the nosings.

TOP TIP

A Ready-Made 6-In. Disk

.....
A full-circle 6-in. protractor works great for checking the triangular sections under stair railings. You can buy one for a few dollars and store it in a toolbox.
.....

STEP 3 Mark the nosing line on the posts

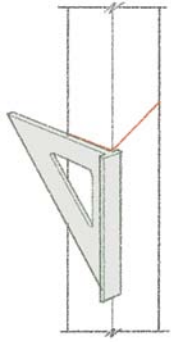

Before removing the rail from the stairs, scribe the posts along the underside of the rail. These lines will serve as references for laying out the length of the balusters, cutting the posts, and installing the section of the balustrade.

STEP 4 Measure the baluster lengths

1 In this example, the top of the guardrail will be 35 in. above the nosing line.

3 Make a bevel cut on a scrap of the rail at an angle that equals the slope, 34.6°. This is the same angle as the one you just marked on the post and the one that's on the stair jig.

8 Measure the distance between the lines representing the top of the lower rail and the bottom of the upper rail. This is the length of the balusters.

5 Hold the bevel-cut end of the scrap on the line, and scribe along the top of the scrap to mark the top of the lower rail.

2 The underside of the bottom rail will be 1/2 in. above the nosing line.

6 Measure 35 in. up from the nosing line on the post to mark the top of the upper rail.

7 Place the bevel-cut scrap on the mark, and scribe along the bottom of the piece. This second mark locates the underside of the top rail.

4 From the nosing lines on the posts, measure up 1/2 in. to mark the bottom of the lower rail. Measure at a right angle to the nosing line. Use the stair jig to extend the line to the corner. Use a square to carry a level line across the inside face of the post.

Nosing line

STEP 5 Lay out the baluster locations on the bottom rails

As with the level sections, the plan for this section of the balustrade is to end up with evenly spaced balusters that are as large as possible without exceeding the 4-in. space allowed by code. To do so, you have to determine how much the key dimensions increase as they go from a level plane to a sloping plane.

Begin by drawing the riser/tread combination on a board as if you were laying out the riser and treads on a stringer. You can do this with the stair jig (or a framing square).

4 Take two measurements along the edge of the board. From the original riser line, measure to the first parallel line. This measurement determines the length of the cross section of a baluster when it's cut at a 34.6° angle. That length is $1\frac{13}{16}$ in.

5 Next, measure from the original riser line to the second parallel line. This measurement determines the length along the sloping surface you have to traverse to move 5.5 in. along a level line. That measurement is $6\frac{1}{16}$ in. or 6.6875 in.

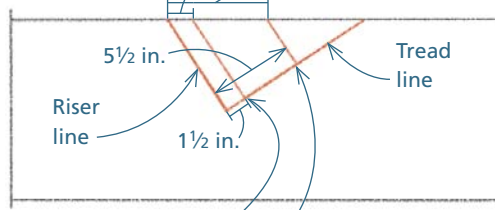

3 Use a stair jig (or a square) to draw lines that run parallel to the riser line from these two marks up to the edge of the board.

1 Starting at the corner where the tread line meets the riser line, measure and mark $1\frac{1}{2}$ in. along the tread line.

2 Next, measure and mark $5\frac{1}{2}$ in. from the same corner.

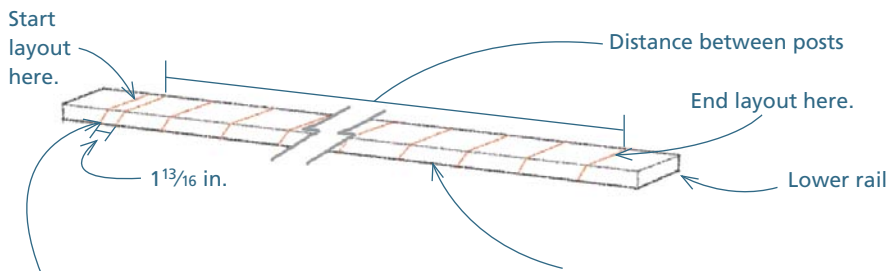

6 To find the overall length of the layout, start by marking on the side of the lower rail a point $1\frac{13}{16}$ in. beyond one of the two marks indicating the distance between the posts. The distance between this mark and the mark at the far end of the rail is the overall length of the layout. In this example, the overall layout is $102\frac{5}{8}$ in. or 102.625.

7 Divide the overall layout by the maximum size of the increment to determine the number of increments: $102.624 \div 6.6875 = 15.34$. Rounding up to the nearest whole number indicates that the number of increments is 16. Divide the overall layout by 16 to determine the size of the increments: $102.625 \div 16 = 6.4140625$.

Use one of the techniques described in "Three Ways to Divide a Space into Equal Increments" on p. 460 to lay out the baluster locations. Start at the mark one baluster width beyond the post-to-post marks and set the layout ahead. When you lay out the increments on the lower rail, mark them on the top of the rail and use a square to carry the marks over to the corners. At the corners, use the stair jig or a bevel square set at a 34.6° angle to draw lines down from the layout on the top surface.

● CUT, ASSEMBLE, AND INSTALL THE SLOPED BALUSTRADE SECTION

In this example, the top rail along the stairs abuts the top post and runs over the bottom post. The process of cutting, assembling, and installing the balustrade can be divided into seven steps.

STEP 1 Check the posts

Use a level to check the posts for plumb. Use the techniques described in the previous section to adjust the posts, if necessary.

STEP 2 Mark and cut the posts

The post at the bottom must be cut to allow the top rail to run over it (the post at the top will not be cut and has already been marked at the point where the top rail will be attached). The height of the rail was established in the process of measuring baluster lengths. The post will be cut along the line that represents the bottom of the upper rail.

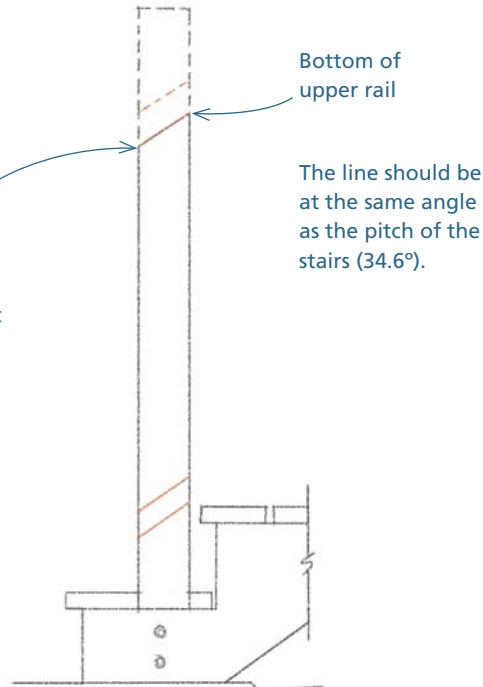

STEP 3 Cut and fit the rails

The bottom rail has already been marked to length. Double-check the marks, then cut it to length. Both the top and bottom have to be cut at a 34.6° bevel.

2 Once you're satisfied with the fit, hold the piece at the mark at the top and let the bottom run over the post at the bottom. Mark the position of the post at the bottom of the rail.

3 Measure and mark the amount that you want the rail to overhang the post (5 in. in this example). Cut the bottom of the rail at a 34.6° bevel with the long point at the mark.

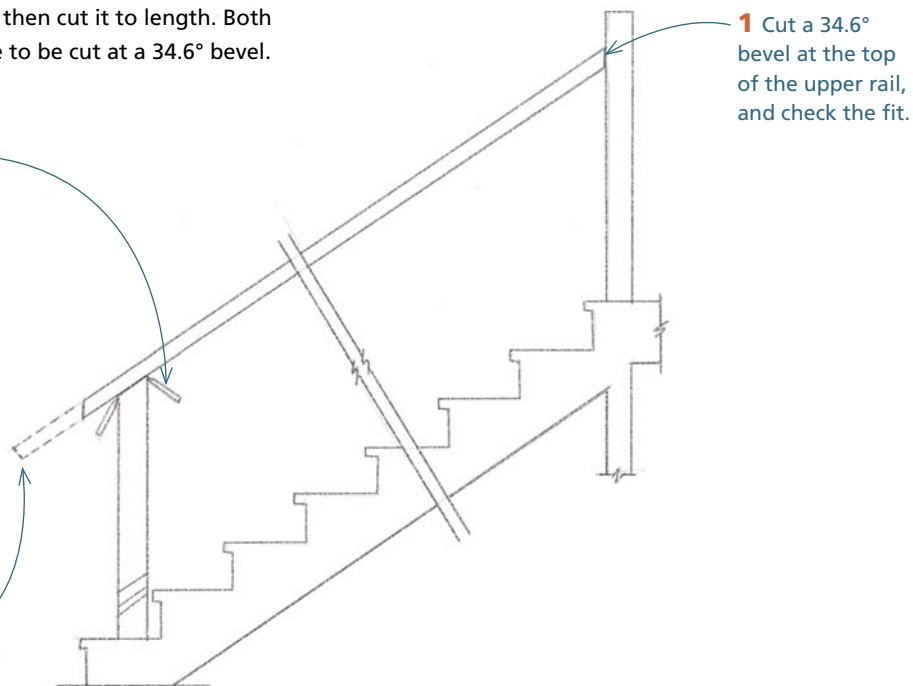

STEP 4 Transfer the baluster locations

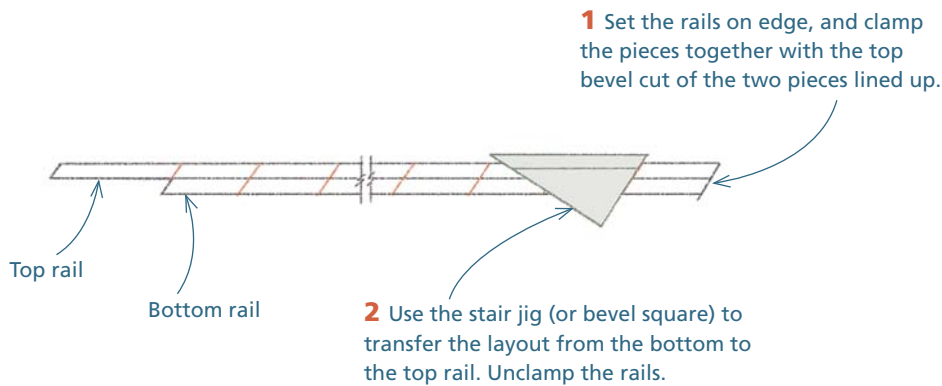

STEP 5 Cut the balusters

The length of the balusters can be transferred directly from the layout already drawn on the posts (see step 4 on p. 475). Measure and cut one baluster with 34.6° miters at both ends. As with square-cut balusters, you can save time and get consistent results by setting up a stop at the saw.

STEP 6 Assemble the section of the balustrade

Use the techniques described in the previous section on building a horizontal balustrade to assemble this sloping section.

STEP 7 Install the section of the balustrade

Lower the section down over the post at the bottom. The section should be wedged in the correct position. Use 16d finish nails, as described in the section on installing the horizontal sections, to fasten the balustrade section to the posts.

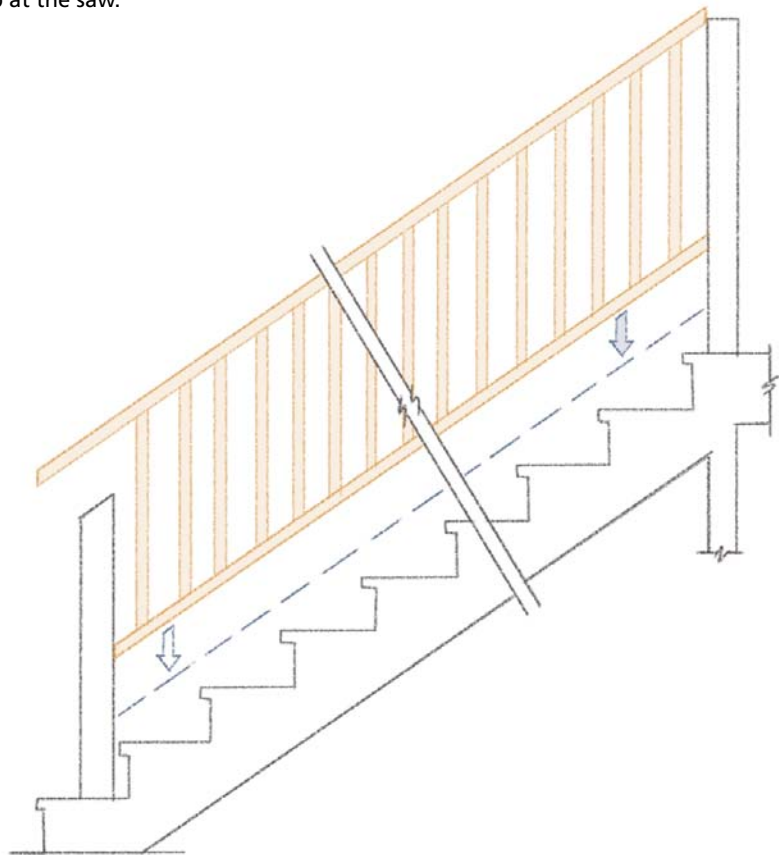

Building Interior Stairs

When you move inside the house to build stairs, you no longer have to worry about frost heave, the pitching of stair treads to shed rainwater, and other measures taken to protect the stairs from the weather. The floors are reasonably level, and there's no need to measure and fit the stairs to the grade. On the other hand, there's no grade to adjust inside the house, which means that interior stairs must fit precisely between two fixed levels. The length of a staircase may be limited by doors, hallways, and walls. And, unlike exterior stairs, interior stairs usually pass through a floor. This means that you often have to lay out and build a stairwell.

Another challenge in building interior stairways is the use of landings. On the inside of houses, where stairways are generally 14 or 15 steps long, landings are often used to divide and turn the stairs. Doing this can improve the use of space and traffic flow. These landings must be precisely built and treated like one of the steps in the stairway.

Perhaps the most nettlesome problem of interior stair building is the fact that the stairs are often built long before the floor coverings are installed. So the builder has to factor in the thicknesses of both floors as well as the thickness of the treads when laying out the stringers. When there's a landing, of course, the stairbuilder also has to account for the floor covering there.

Some details in the framing of interior stairs are different from those of exterior wood stairs, but the overall process is essentially the same. Both types of stairs must meet the same code requirements, and all of the layout techniques used outside can be used inside.

Laying Out the Stairwell

In most houses, the stairwell is a simple rectangular opening framed into the floor system. The actual framing is a straightforward process that's discussed in chapter 2. Before you build the stairwell, however, you must determine its length and width. These dimensions are not always specified, and calculating them on site is more difficult than it might seem. It's complicated by the fact that the stairwell is often framed when the floor system is built, which might be weeks or months before you build the stairs.

Lay out the width The width of the rough opening of the stairwell is the easier of the two dimensions to determine. Before you start, you have to know two things: the desired width of the finished stairway and the materials that will be used to finish the wall (or walls) along the sides of the stairs. Add the combined thickness of the finished materials to the planned width of the finished stairs to determine the width of the rough opening.

Allow extra room in the length The length of the stairwell depends on several factors and is much more difficult to determine than the width. One approach is to allow extra length when you frame the floor initially. Then, when you get to the stairs at a later date, it's fairly simple to shorten the opening to its finished length by adding material at one end.

In this example, the opening is far longer than normally required for a house with 8-ft. ceilings. When you turn your attention to the stairs, you'll be starting with an oversized opening 13 ft. long.

The length of the framed stairwell is dependent on several factors, including the depth of the upper floor system, the manner in which the stairs will be attached at the top, the materials planned for finishing the inner edge of the stairwell, and the riser/tread combination. Once you have this information, you can determine the minimum length of the stairwell.

• CALCULATE THE RISER/TREAD COMBINATION

STEP 1 Establish the heights of the finished floors

Here, the floor covering on the lower floor will be 2 in. thick. Flooring on the upper floor will be $\frac{3}{4}$ in. thick. Make a block equal to the thickness of each of these floor coverings. Set these on the subfloor of each level to mock up the final heights of the floors.

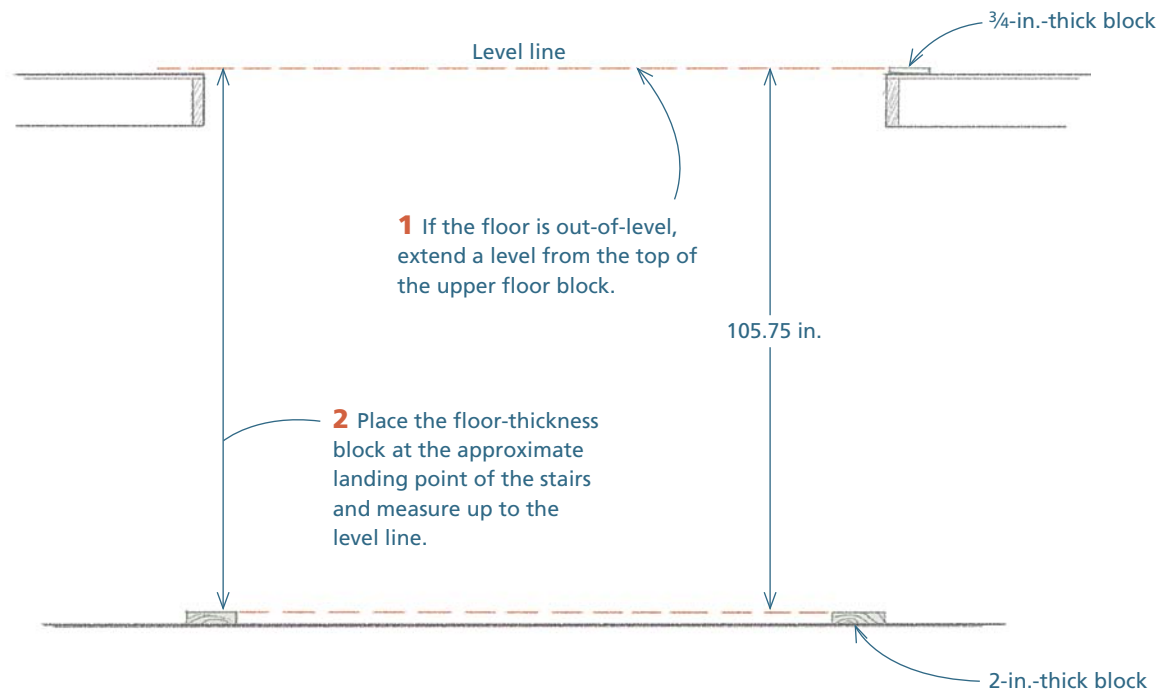

STEP 2 Measure the total rise

Begin by making sure the landing point at the bottom of the stairs is level with the floor directly below the landing point at the top of the stairs. If you find that the lower floor is out of level, extend a level line over from the top of the floor thickness block on the upper floor and then measure straight down from that point. Measure from the top of the lower floor thickness block to the top of the upper floor thickness block to determine the total rise. In this example, the total rise is 105.75 in.

STEP 3 Establish the total length

A door opening, which has not yet been trimmed out, is about 12 ft. away from the point on the stairwell where the stairs will begin.

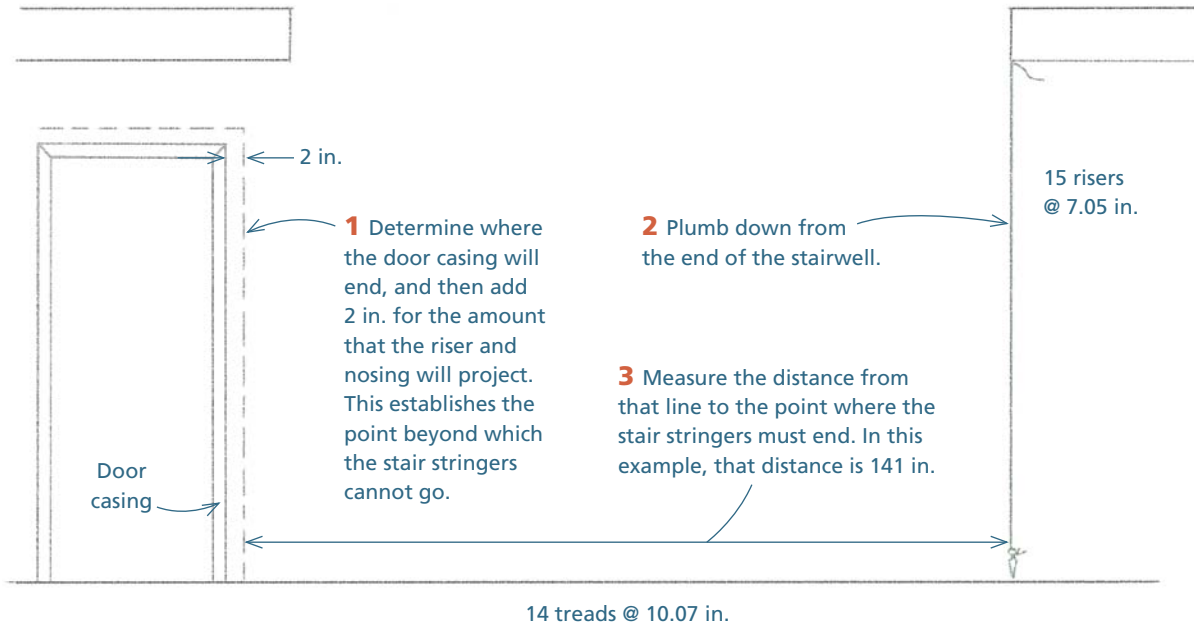

STEP 4 Determine the riser/tread combination

Divide the total rise by 7 to determine the number of risers needed: $105.75 \div 7 = 15.107$. Rounding this result indicates that there should be 15 risers. Divide the total rise by 15 to find the size of a single riser: $105.75 \div 15 = 7.05$.

Because the stringers will be attached one-riser height down from the top floor, there will only be 14 treads. Divide the total length by 14 to determine the size of the tread depths: $141 \div 14 = 10.07$. The riser/tread combination for this example is 7.05/10.07.

● CALCULATE THE LENGTH OF THE STAIRWELL

Once you have the riser/tread combination in hand, you can calculate the length of the stairwell.

1 Add the depth of the floor system to the required headroom. In this example, the finished floor system will be $11\frac{1}{4}$ in. thick. Add this to the required headroom: $11.25 + 80 = 91.25$. The total descent needed to go from the top floor to the required headroom is 91.25 in.

2 Determine the number of steps. Divide 91.25 by 7.05 and round up to the nearest whole number: $91.25 \div 7.05 = 12.94$ (13, rounded). This indicates that 13 steps are needed to get below the required 80-in. clearance.

4 Determine the length of the rough stairwell. Add the thicknesses of the finish materials and the final projection of the nosings to find the size of the framed stairwell. In this example, these thicknesses add up to $2\frac{1}{4}$ in. Therefore, the rough stairwell should be at least 133.16 in. long ($130.91 + 2.25$). Build the stairwell to this length.

3 Determine the minimum length of the finished stairwell. Multiply the tread depth by the number of steps down: $10.07 \times 13 = 130.91$. This is the minimum length that the finished stairwell should be.

5 Decide how to attach stringers. If you have enough space and want to attach the stairs flush with the upper floor, add an extra riser and a partial tread (about 7 in. in width). Make the stairwell longer by the width of the tread.

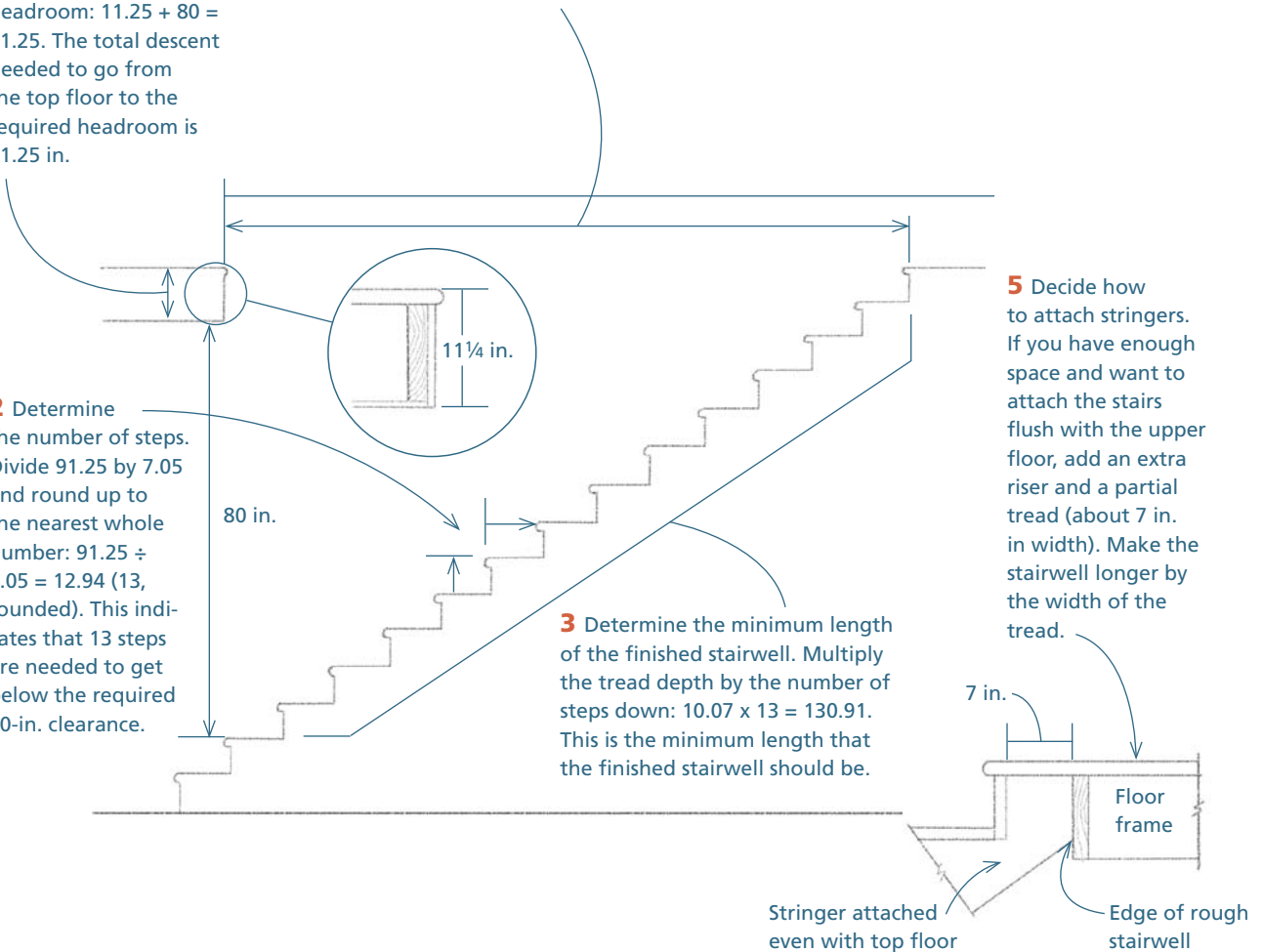

● LAYING OUT THE STRINGERS

Using the riser/tread combination found in the previous section, lay out the stringers by following these steps.

Step 1 Divide the overall layout into equal increments

Find the combined length of 15 treads: $10.07 + 141 = 151.07$. Calculate the hypotenuse of a triangle with an altitude that equals 15 risers (105.75) and a base that equals 15 treads (151.07):

$$H = \sqrt{A^2 + B^2}$$

$$H = \sqrt{105.75^2 + 151.07^2}$$

$$H = 184.405 \text{ (} 184\frac{3}{8} \text{ in.)}$$

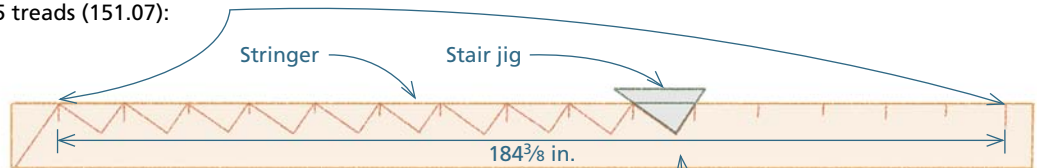

Make two marks $184\frac{3}{8}$ in. apart on the top of the stringer material. Use one of the techniques described in "Three Ways to Divide a Space into Equal Increments" on p. 460 to divide the 184.405-in. space into 15 equal increments.

Step 2 Lay out the risers and treads on the stringer.

Make a stair jig with a rise of $7\frac{1}{16}$ in. and a run of $10\frac{1}{16}$ in., and lay out the risers and treads on the stringer, as described in "Laying out wood stringers" on p. 454.

STEP 3 Lay out the top and bottom steps

Top of stringer

1 To lay out the level at which to install the top of the stringers, start by setting the floor thickness block on the edge of the stairwell.

2 Measure and mark one riser height ($7\frac{1}{16}$ in.) down from the top of the block. This mark represents the top of the finish tread.

4 To lay out the cut at the top of the stringer, extend the final riser line down to the bottom of the stringer.

3 Measure down the thickness of the tread (1 in. in this example) from the mark to indicate the level at which the stringers should be installed.

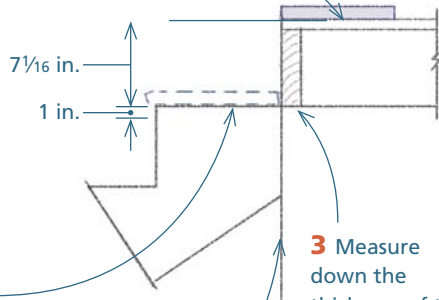

Bottom of stringer

5 To lay out the bottom, draw the finish tread on the first tread of the stringer.

6 Measure and mark one riser height ($7\frac{1}{16}$ in.) down from the top of the drawn-in tread. Use the stair jig to draw a line at the mark, indicating the top of the finished floor.

Top of finished floor

Cut this line.

7 Place the floor thickness block on the finish floor line, and scribe along the bottom edge to draw in the thickness of the floor covering. Cut along this second line.

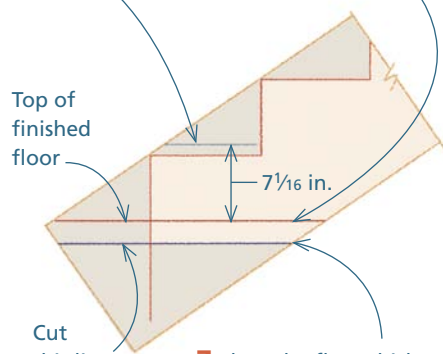

● LAYING OUT LANDINGS

Landings are simple platforms that are easy to frame. As with a stairwell, the main challenge is in the layout. In the finished stairway, the landing should be the same width as the stairs.

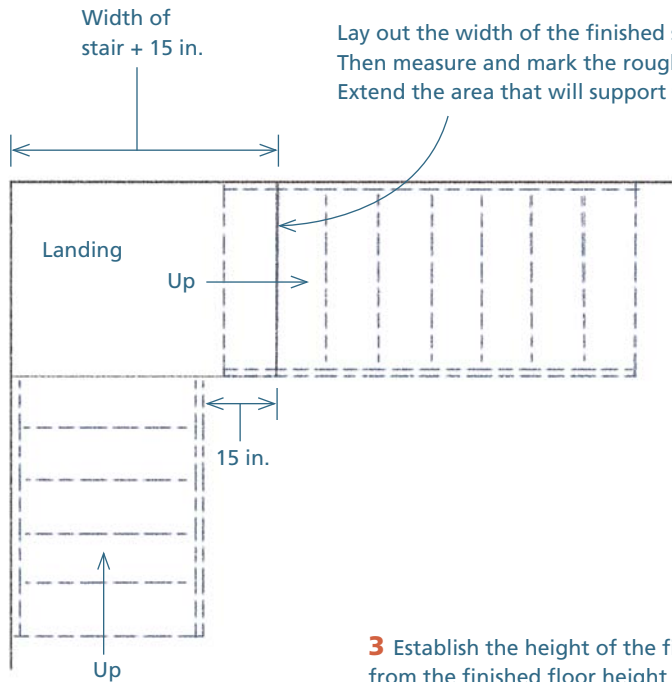

Lay out the width of the finished stairs and landing on the floor. Then measure and mark the rough landing inside that layout. Extend the area that will support the upper flight about 15 in.

The height of the finished landing has to fit precisely into the riser pattern of the stairs. The risers up and down from the landing, in other words, have to be exactly the same height as all the other risers in the finished stairs. The layout can be divided into four steps.

3 Establish the height of the finished landing. Measure down in full riser increments from the finished floor height at the top. In this example, the finished landing is nine riser increments down from the top ($9 \times 7.05 = 63.45$). Mark this height on the wall. To double-check this height, multiply the remaining risers by the unit riser height: $6 \times 7.05 = 42.3$. Add this to 63.45 to see if they equal the total rise: $42.3 + 63.45 = 105.75$.

1 Measure the total rise. The total rise in this example is 105.75 in.

2 Decide on a riser/tread combination. In this example, the riser/tread combination is 7.05/10.07 and there will be 15 risers.

4 Mark the height of the rough landing. Measure and mark an amount equal to the thickness of the floor covering down from the top of finished landing mark. In this example, the floor covering will be $\frac{3}{4}$ in. thick. The top of the rough landing, including the plywood sheathing, should end up at this mark.

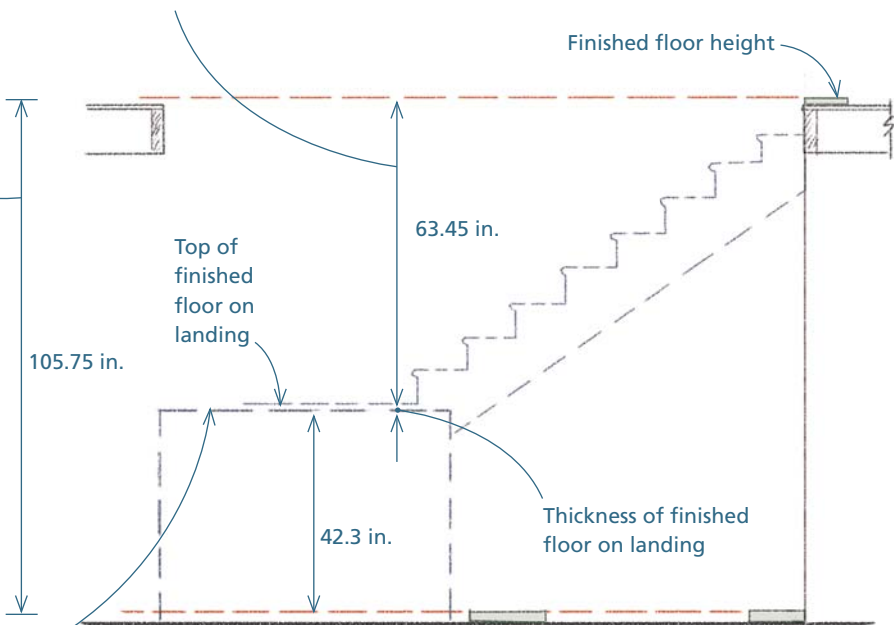

WAYS OF WORKING

Materials for the Stringers

Solid-sawn lumber has been used for stringers for centuries. If the stairs will be partially or fully supported by walls (either under or running beside the stairs), 2x12 stringers work fine. If the design calls for an open space below the stringer, the stringer material and the details of the design should be specified by an architect or structural engineer.

Engineered lumber is also used for stringer material. In every respect except price, it is superior to solid-sawn lumber. It's stronger and less likely to warp, cup, or split. And it's far more dimensionally stable than solid-sawn wood. This stability means that stairs built with engineered wood stringers are less likely to develop squeaks. For most jobs, 11⁷/₈-in. x 1¹/₄-in. laminated strand lumber (LSL) works well for the stringers. To keep the treads from deflecting, the distance between the stringers should not exceed 24 in. Typically, three stringers are required. Don't overcut the stringers; use a jigsaw to finish the cuts in the corners.

Cutting and Installing Interior Stringers

Interior stairs are often supported by walls on both sides. Where no walls are planned, you can either beef up the stringers or install a support at midspan.

● FASTENING THE STRINGERS WHEN THE STAIRS RUN ALONG A WALL

For staircases that run up along a wall that will be finished with drywall, you can save time by sandwiching a 2x4 spacer between the wall frame and the stringer. Afterwards, you'll be able to slide both the drywall and a finish skirtboard into the space without having to fit these materials around the stairs.

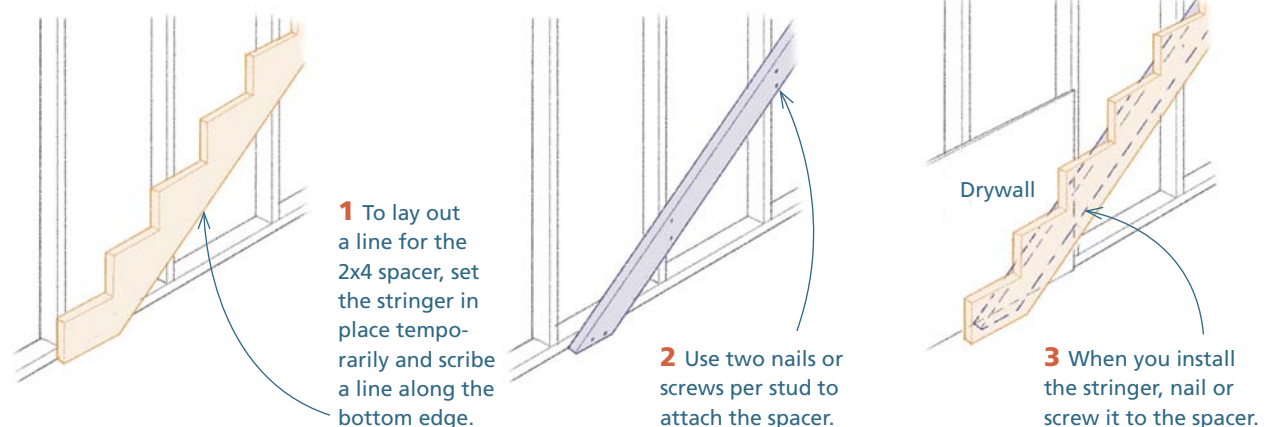

● FASTENING FREE-SPANNING STRINGERS

Stairs that don't run along a wall and will not have a wall built under them, such as the stairs that lead down to the center of a basement, depend on strong connections at both the top and bottom of the stringers. In general, the stringers want to move down at the top and thrust out at the bottom.

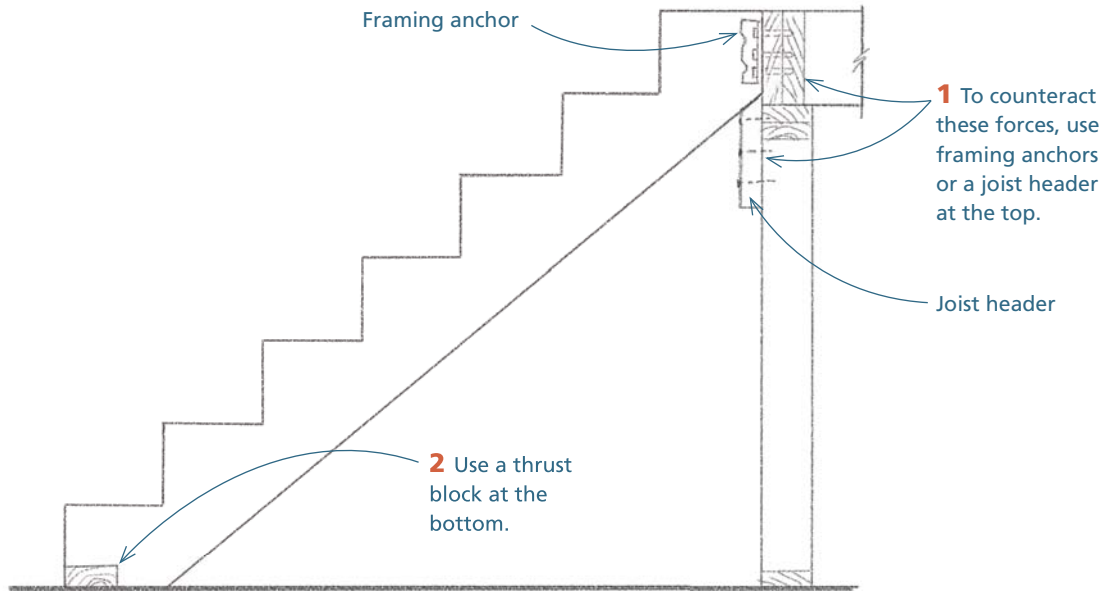

Installing Newels, Skirtboards, Risers, and Treads

The sequence for installing the finish materials varies according to the system being used and the preferences of the installer. A common sequence of installation is:

- Newels
- Skirtboards
- Risers
- Treads

This sequence will be followed in the example shown here.

• INSTALLING THE NEWELS

To install newels in the right place, you have to think several steps into the future, anticipating the buildup of the materials that will be installed later. Among these materials are drywall, skirtboards, risers and treads, and balusters. The easiest way to do this is to divide the layout into two parts: location and height.

• LAYING OUT THE LOCATIONS (PLAN VIEW)

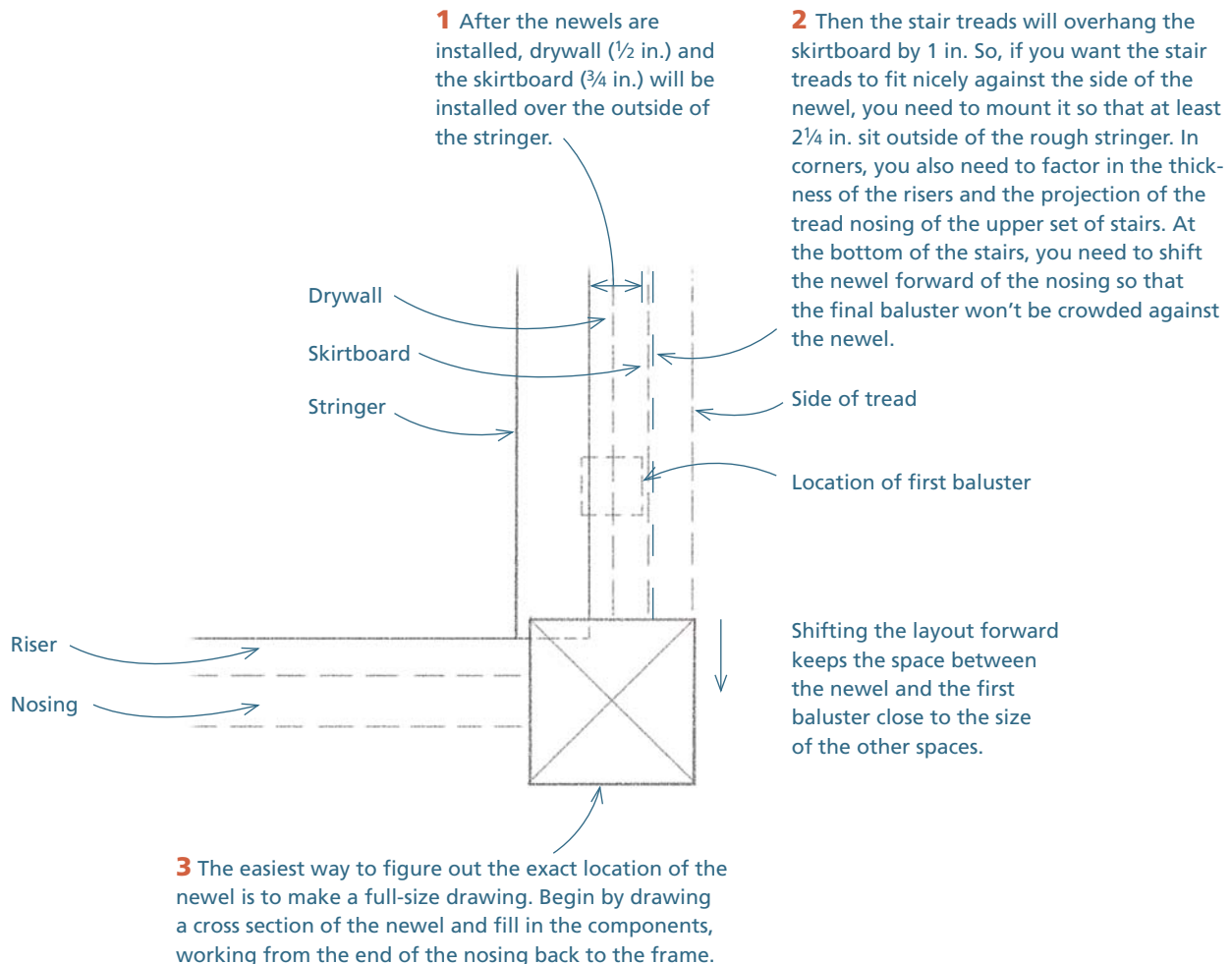

• LAYING OUT THE HEIGHT

1 After laying out the location of the newel, attach a board the same width as the newel on the layout and brace it plumb. In this example, the newel is 3½ in. wide, so a 2x4 works well.

2 Scribe along the top of the level cut of the stringer to mark its position on the 2x4. This mark will serve as a reference for laying out the notches on the newel.

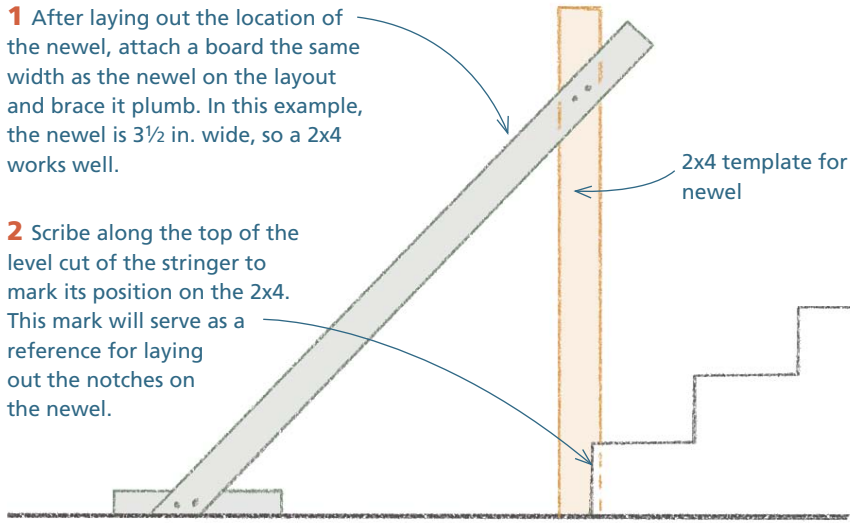

4 Hold a straightedge, such as a 4-ft. level, so that it runs over the nosings of the temporary treads.

3 Temporarily attach two treads in the exact position that the finished treads will be installed.

5 Mark the nosing line on the 2x4.

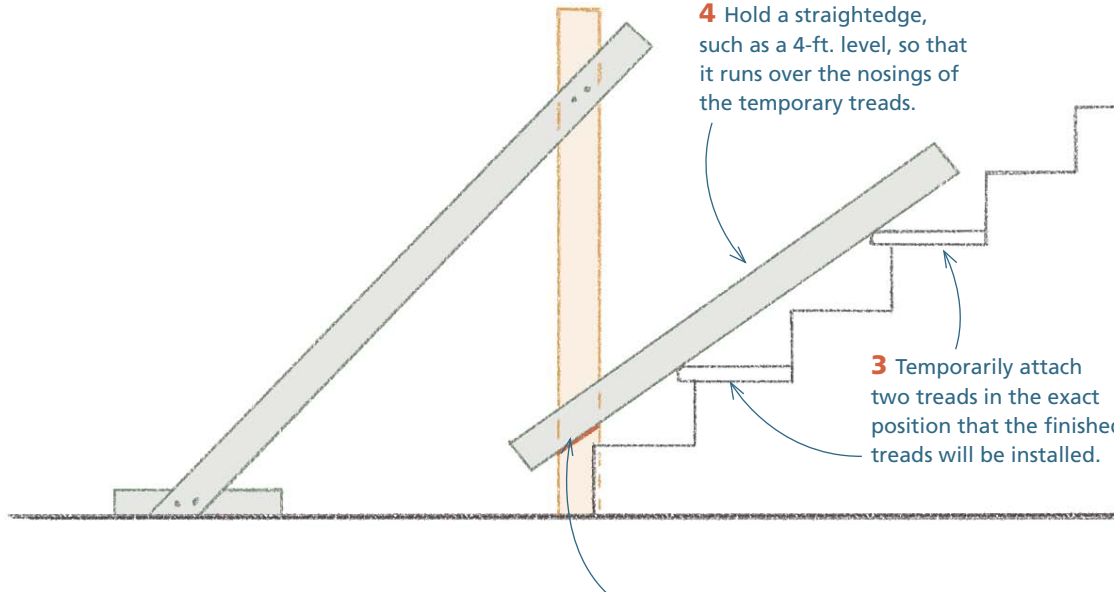

• CUTTING AND NOTCHING THE NEWELS

To locate newels precisely on the layout, they usually need to be notched to fit over the stair stringer, the landing, or the balcony at the upper floor. Newels located in corners have to fit over two things at the same time, thus requiring compound notches. Because newels are usually finished at the top and often have a specific area to which the rails can be attached, start the layout at the top.

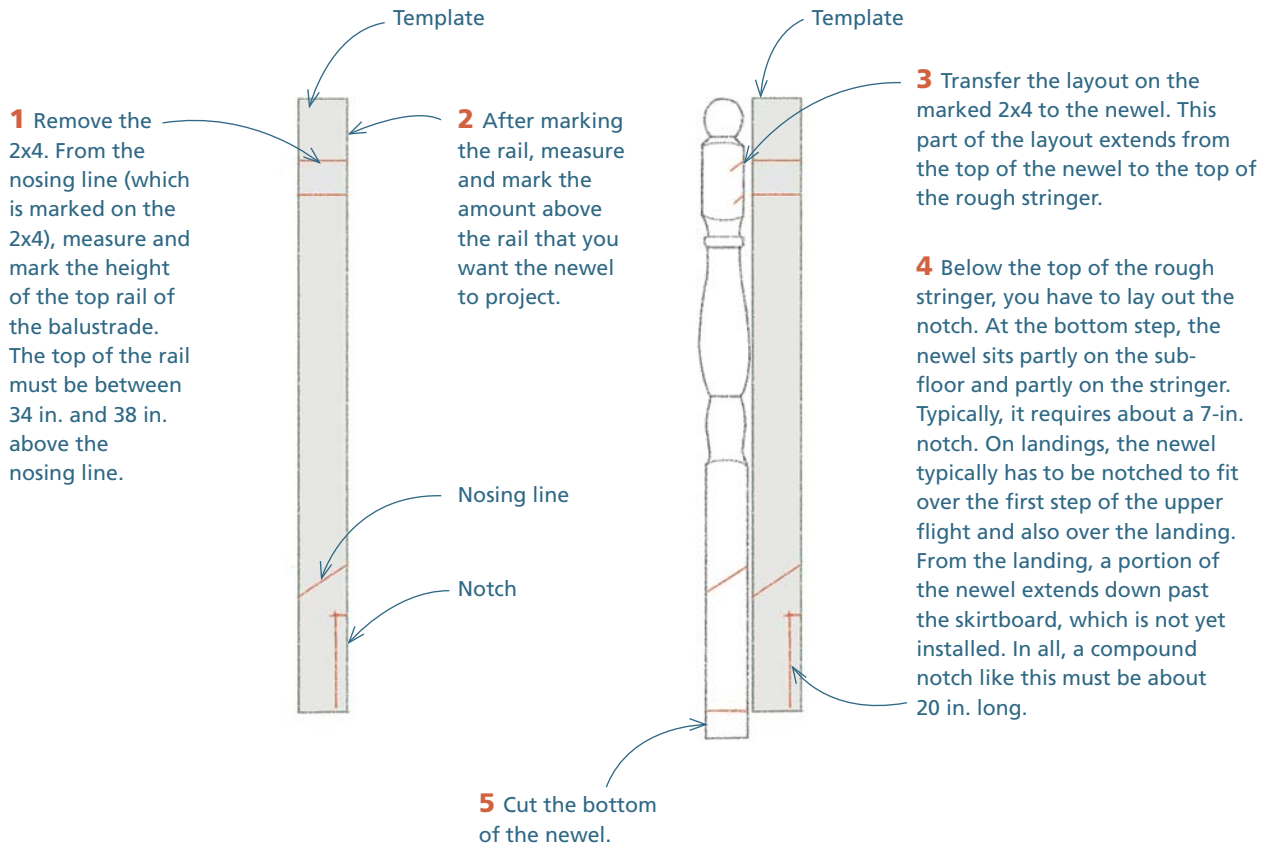

To lay out the height (or heights) of the notch, hold the newel in place and mark the locations of the things that the newel must overlap. To lay out the depths of the notch, carefully measure the amount that the newel has to move to reach its location. This is a piecemeal process and you should approach it methodically. Techniques for cutting notches are discussed in the sidebar “Cutting Notches in Newels” on p. 491.

● ATTACHING THE NEWELS

The way newels are attached varies with the design of the balustrade.

1 The starting newel at the base of the stairs can be bolted to the floor with special hardware, such as the Sure-Tite™ fastener (available from L. J. Smith Stair Systems at www.ljsmith.com). Follow the instructions that come with the hardware.

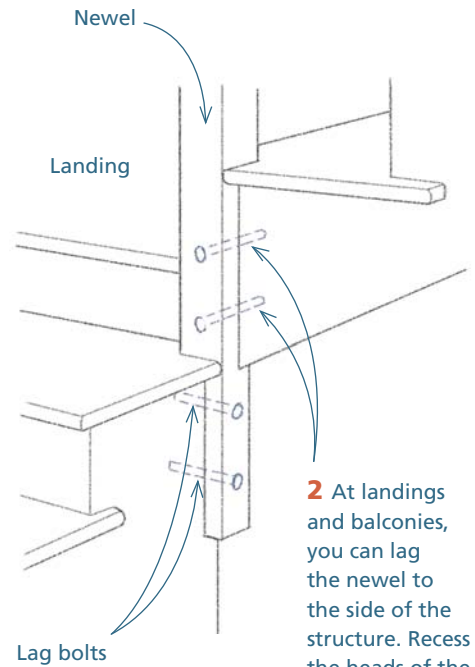
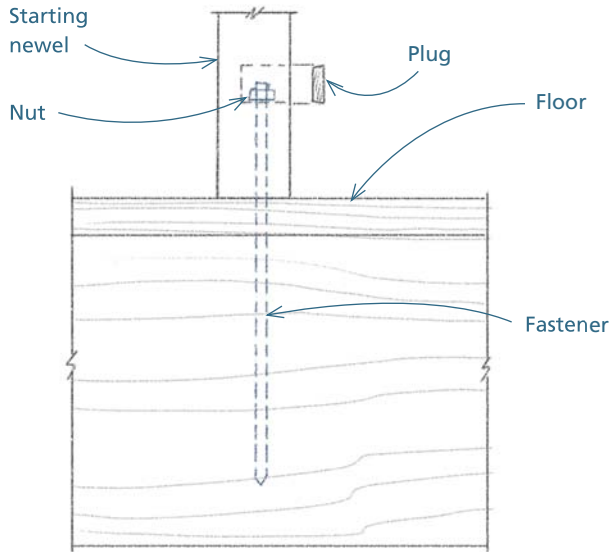

2 At landings and balconies, you can lag the newel to the side of the structure. Recess the heads of the screws and cover them later with plugs.

Installing the Skirtboards

In this example, the drywall was hung and finished after the stair stringers were installed. Because a 2x4 spacer was used on the stringer against the wall, the drywall could slip into the slot between the stringer and the wall, leaving a 1-in. gap for the skirtboard along the wall.

● INSTALLING THE SKIRTBOARD ALONG THE WALL

The skirt should gracefully join the baseboard along the top and bottom floors and along the landing, if the stairway has one.

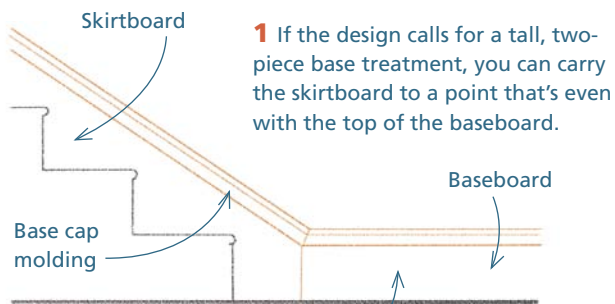

1 If the design calls for a tall, two-piece base treatment, you can carry the skirtboard to a point that's even with the top of the baseboard.

2 After installing the baseboard, continue the base cap molding over the skirtboard.

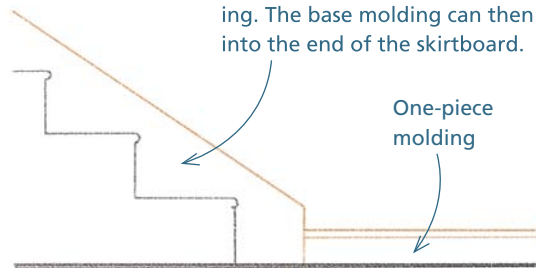

3 If the design calls for a small, one-piece base molding, you might cut the skirtboard square to the floor and a few inches taller than the base molding. The base molding can then butt into the end of the skirtboard.

ESSENTIAL SKILLS

Cutting Notches in Newels

.....

Notches are cut with a combination of power and hand tools. To cut a simple, rectangular notch at the bottom of a treated post or an interior newel, start by setting the circular saw to the depth of the notch.

1. Crosscut the newel along the layout line, and from there crosscut the piece every $\frac{1}{4}$ in. or so. These cuts don't have to be square to the edge; you can make them by eye. The main concern is the depth of the cut, so make sure you hold the table of the saw flush with the surface all the way through the cut.

2. Break away the thin wafers left between the kerfs with a hammer.

3. Use a sharp chisel to clean up the bottom of the notch.

4. A sharp plane also is an effective tool here.

On notches that extend to the end of the post (or newel), you can stop kerfing the piece after a few inches and make the rest of the notch by making two rip cuts with the circular saw.

On notches that don't go all the way across the newel, you can't use the kerfing method. Make two rip cuts and then use a chisel to finish the inside corner of the notch.

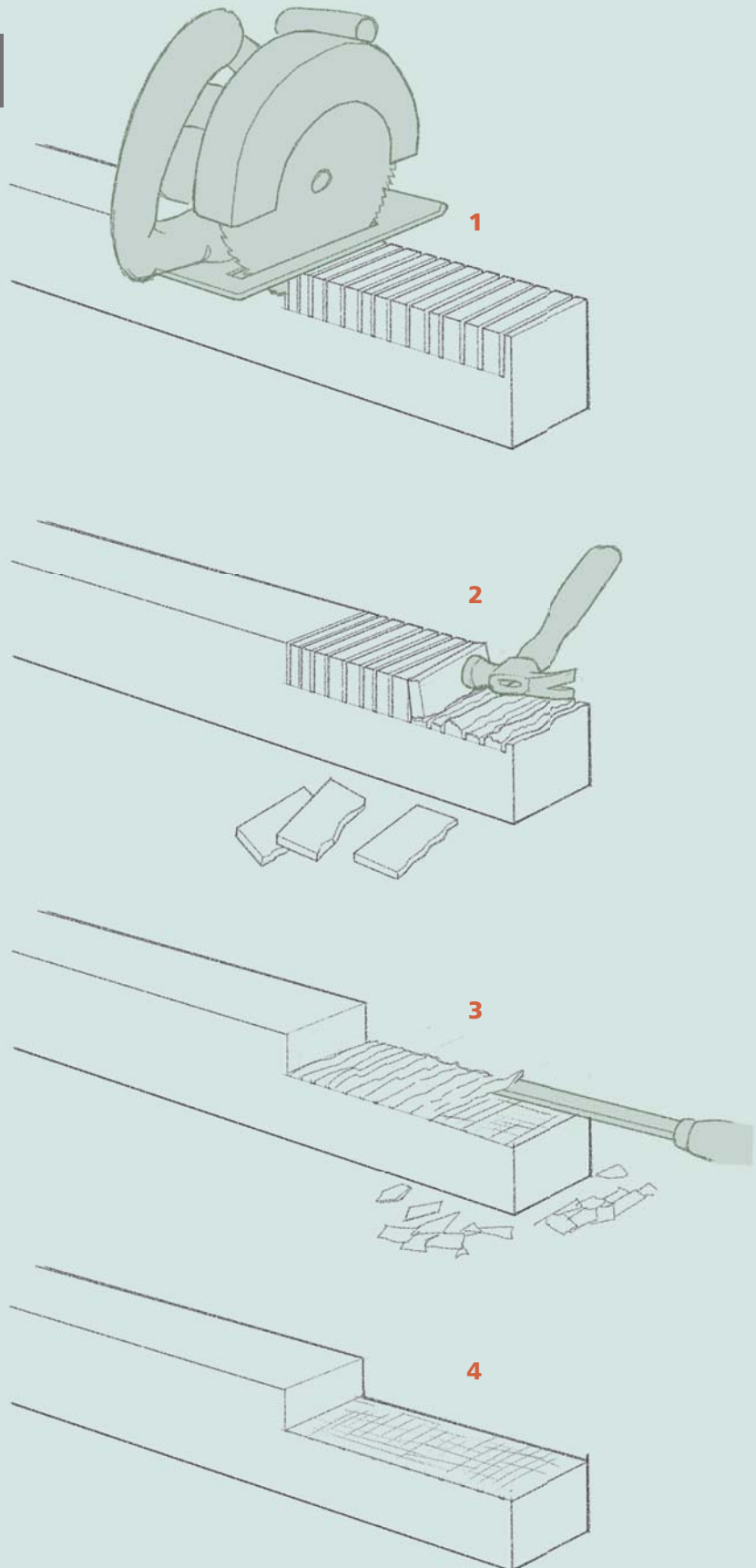

● INSTALLING THE SKIRTBOARD ON THE OPEN SIDE

The skirtboard on the open side of the stairs must fit between the newels.

1 Place a straightedge along the nosing of the stairs, and set a combination square to a length that's just short of the combined width of the skirtboard and the straightedge.

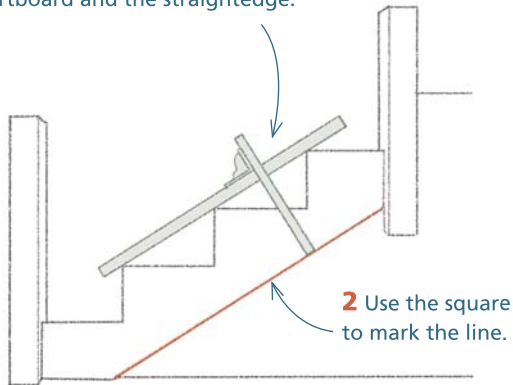

3 At the top of the stringer, use a bevel square to measure the angle.

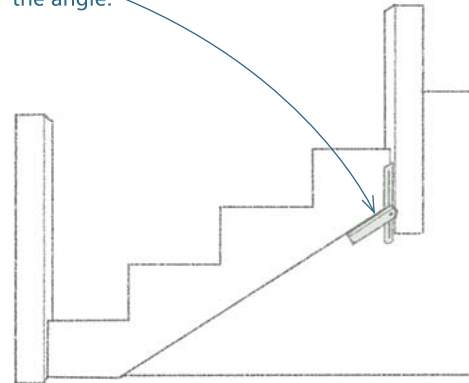

4 Transfer that angle to the skirtboard material.

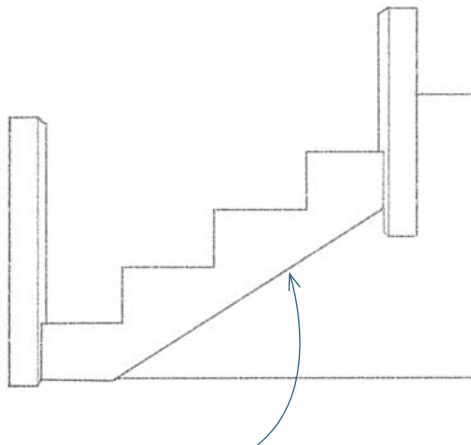

5 Measure the distance along the line representing the bottom of the stringer.

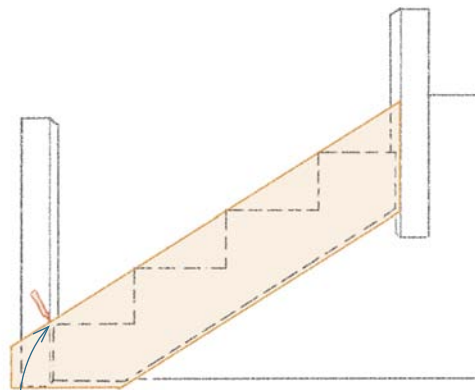

7 Hold the skirtboard in place, and scribe along the lower newel to mark the vertical cut. Cut the board along this line.



6 At the bottom of the line marked on the wall, use a bevel square to measure the angle between the line and the floor and transfer it to the skirtboard. Cut the skirt at these two angle lines.

8 Temporarily attach the skirtboard to the side of the stairs, and use a straightedge spanning all three stringers to transfer the location of the risers and treads to the inside of the skirtboard. For the risers, use a scrap of the riser stock as a spacer to lay out the location of the outside face of the risers.

9 Use a square to transfer the layout from the inside of the skirtboard to the outside face. Set your saw to a 45° bevel, and cut along the lines representing the risers. Set the saw to 0° to cut the lines representing the treads.

10 Return the skirtboard to the stairs and reinstall it.

Installing the Risers and Treads

Because the skirtboards are rarely perfectly square to the stringer and because the miter cuts on the open skirtboard are usually a bit off, you have to fit each riser and tread to the skirtboards and the stringers. Carpenters have many ways of approaching this fussy job, and the following example is just one of many possible ways to do it.

● FITTING THE RISERS

The risers, which have to join the open skirtboard at a long 45° miter, are especially difficult to fit. You don't have the luxury of leaving one end long, fitting one joint, and then cutting and fitting the other. You have to fit both joints and the length at the same time.

One way to achieve high-quality results is to use a template. If you expect to build more than one set of stairs, you might consider investing in a manufactured tool designed for this task (such as the Wheaton Tools PL200 Stair Wizard). If the stairs are a once-in-a-decade job, you can make a simple template. Here's one version of a site-built template:

1 Cut a strip of $\frac{3}{4}$ -in. plywood the same height as the riser and about $1\frac{1}{2}$ in. shorter than the space between the skirtboards. Temporarily screw it in place with about a $\frac{3}{4}$ -in. space at each end.

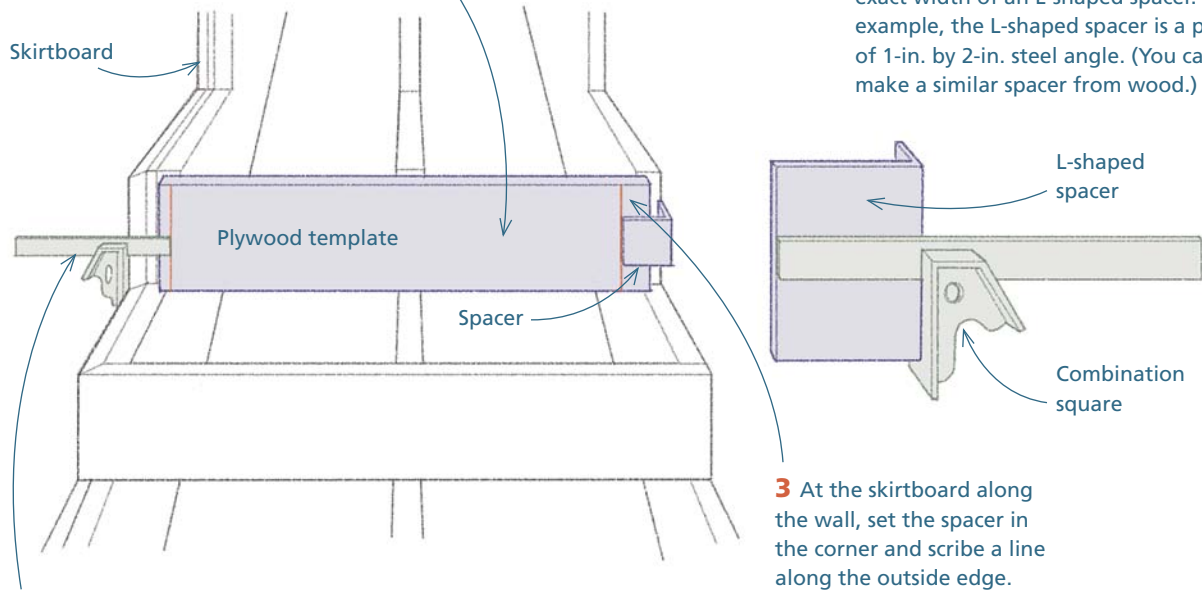

2 Set a combination square to the exact width of an L-shaped spacer. In this example, the L-shaped spacer is a piece of 1-in. by 2-in. steel angle. (You can make a similar spacer from wood.)

3 At the skirtboard along the wall, set the spacer in the corner and scribe a line along the outside edge.

4 At the other end, use the combination square to mark the offset.

Remove the template and place it over the riser material.

5 On each end, place the L-shaped spacer on the line.

6 Mark a parallel line the correct distance from the offset line.

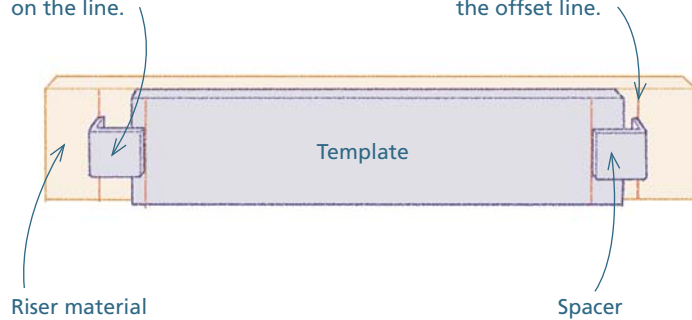

The only part of the joints that will show in the finished stairs is at the outside.

7 To make sure the outside of the miter joint is closed, set your saw to 46° and cut about 1/16 in. outside the line.

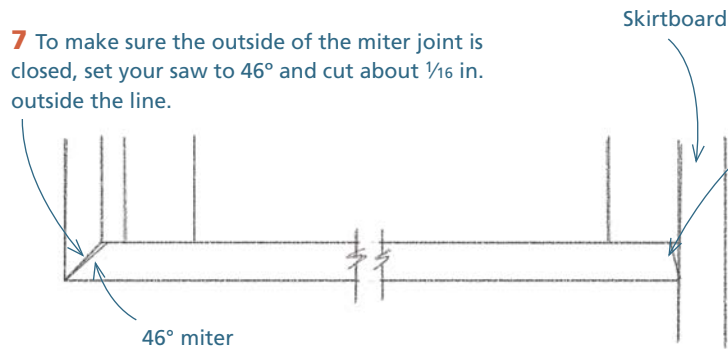

8 On the other side, where the joint is a simple butt joint, set the saw to 1° to help close the visible outside edge of the joint. You may have to do some final touchup with sharp edge tools or a sanding block before installing the riser. When you're satisfied with the fit, use two finish nails or trim screws per stringer to attach the riser.

● FITTING THE TREADS

The treads are easier to fit than the risers because they overlap the stringer on the open end. In this example, the treads come with factory-installed mitered returns.

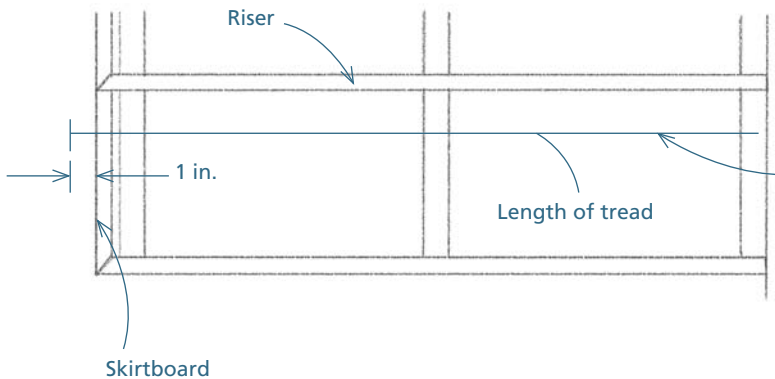

1 Measure the distance from the outside of the open skirtboard to the face of the skirtboard that's attached to the wall, and add an inch (to allow for the overlap at the open stringer) to the measurement. Mark this length on the tread.

2 Starting at the outside of the mitered return of the tread, measure and mark the length on the finish tread. Add 1 in. and cut the tread at that line.

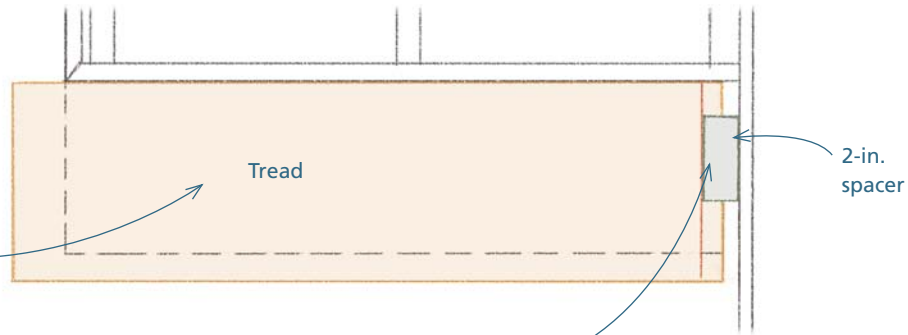

3 Set the tread on the stringers, and place a 2-in. spacer on top of the tread (a piece of wood works fine). Hold the spacer against the skirtboard, and slide the tread until the mark lines up with the edge of the spacer. Make sure you keep the tread against the riser and the spacer against the skirtboard. Draw a line along the edge of the spacer. Cut to the line. Check the fit and fine-tune the cut, if necessary.

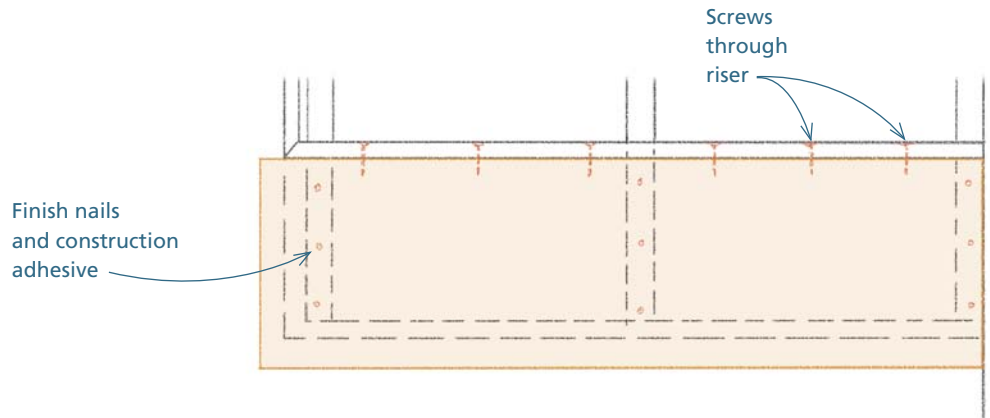

4 When you're satisfied with the fit, install the tread. Use construction adhesive and three finish nails or finish screws per stringer. From under the stairs, drive several screws through the riser and into the back edge of the tread.

Installing the Balustrade

There are many styles of balustrades and many ways they can be assembled and installed. The manufacturers of these different systems offer specialized hardware and provide detailed instructions on how to assemble their products. To install the railings, follow the instructions and use the hardware provided by the manufacturer of the stair parts. In this section, we'll focus on the layout and installation of the balusters.

Laying Out a Code-Complying Balustrade

Unlike exterior stairs, where a bottom rail is often used, the balusters on most interior stairways go all the way down to the treads. In this section, we'll discuss the layout of a balustrade along an open-stringer stairway in which the tread depth is $10\frac{1}{16}$ in. and the balusters are narrow "pool cue" balusters. To comply with the code, we must use three balusters per tread.

● SUPERIMPOSING AN EQUALLY DIVIDED LAYOUT ON THE STAIRS

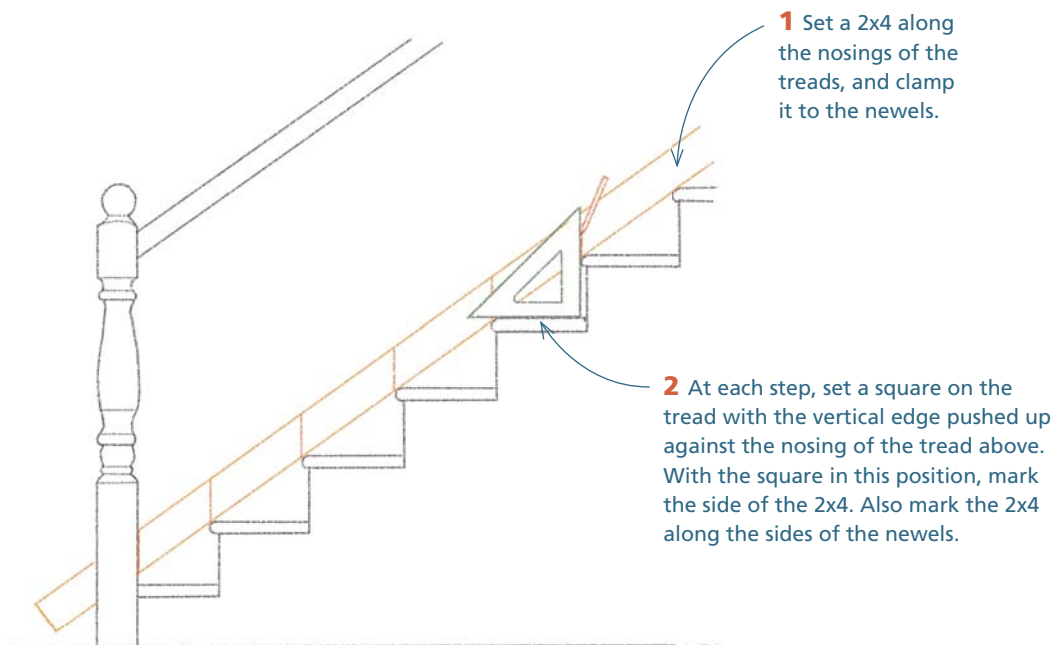

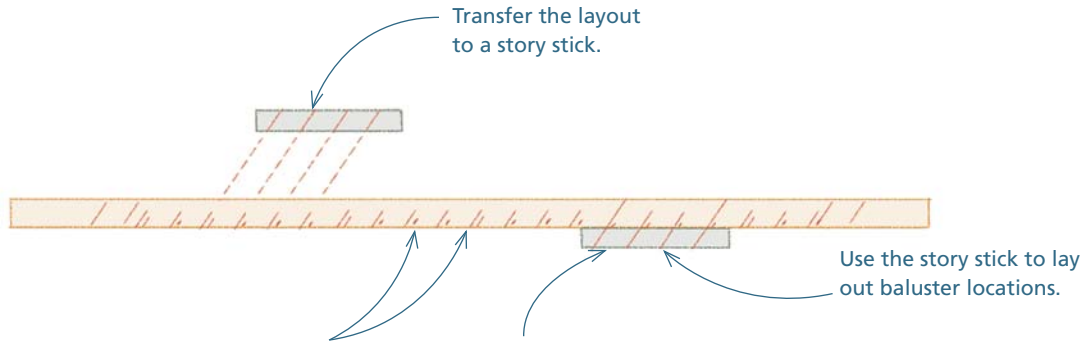

5 Use the rafter jig (or a bevel square) to transfer the lines on the top of the 2x4 to the side. These lines should run at the same angle as the lines first marked on the side of the 2x4. At each line on the side of the 2x4, draw in the thickness ($\frac{3}{4}$ in.) of the balusters.

4 Use the story stick to extend the pattern into the two spaces adjacent to the newels.

3 Remove the 2x4. All the spaces between the marks should be equal except the ones adjacent to the newels. Carry the marks over to the top of the 2x4, and use a square to mark lines that are perpendicular to the edge. Divide the spaces between the lines that are the same size into three equal increments. Since these are identical in size (or very close to being identical), you can divide one space into three equal increments, transfer that layout to a story stick, and then use the story stick to lay out the rest of the spaces.

• AT THE STAIRS, MARK THE LOCATION OF A BALUSTER ON ONE OF THE TREADS

Ordinarily, the front of the baluster lines up with the face of the riser below it.

1 Set a square on the tread just below, with the vertical edge against the nosing.

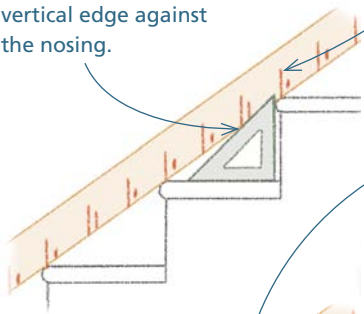

2 Measure and mark 1 in. (the projection of the nosing) in from the blade of the square. Doing this marks the face of the riser. This mark lays out the position of the front of the base of the baluster, which is $1\frac{1}{4}$ in thick.

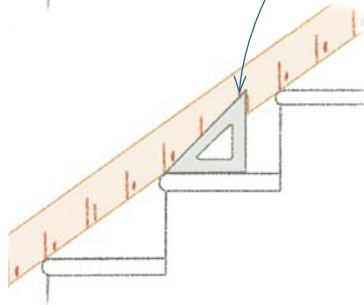

3 Hold a square on this second mark. Set the 2x4 on the nosings, and slide it along the stairs until the layout line representing the front of a baluster lines up with the blade of the square. Check the layout of the balusters adjacent to the newels. The spaces between the last balusters at both ends and the newels are usually different from the other spaces. You have to accept this inconsistency because the baluster layout is linked to tread size. However, at this point you can move the entire layout a small amount, if necessary. In this example, the baluster layout is acceptable in relation to the newels. (Here's where foresight at the time of laying out the newel location at the bottom of the stairs pays off.)

4 Clamp the 2x4 story stick in place, and use a square to transfer the layout from the 2x4 to the stair treads. Transfer both lines for each baluster.

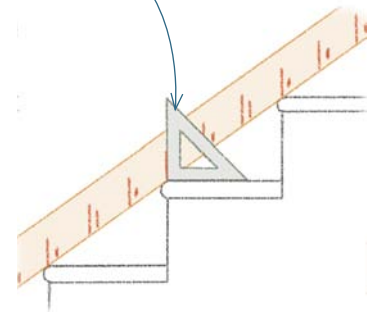

● INSTALLING THE BALUSTERS

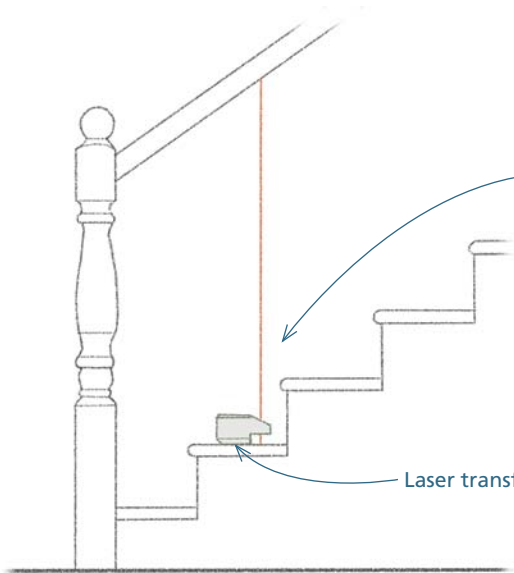

1 Mark the center of each baluster on the stair treads. In this case, the centerline is $1\frac{3}{4}$ in. in from the ends of the treads and midway between the two marks you made for the baluster layout.

2 Transfer the center marks up to the underside of the top rail. The best tool for this job is a self-leveling laser with a plumb (vertical) dot or line. If you don't have a laser, you can use a level to make a mark on the side of the rail and then carry the layout to the underside of the rail.

Laser transfers layout to underside of rail.

● DRILL HOLES IN THE TREADS AND THE UNDERSIDE OF THE RAIL TO RECEIVE THE BALUSTERS

2 The hole at the top must be fairly deep and slightly larger than the balusters. For the $\frac{3}{4}$ -in. balusters in this example, use a $\frac{13}{16}$ -in. bit and drill the holes $1\frac{3}{4}$ in. deep. When you install the baluster, you'll have to slide it far enough up into the rail to allow the dowel at the bottom to clear the tread. Once it's over the hole at the bottom, you can slide it down into the hole. As with the bottom, tape the drill bit to show when you reach the desired depth.

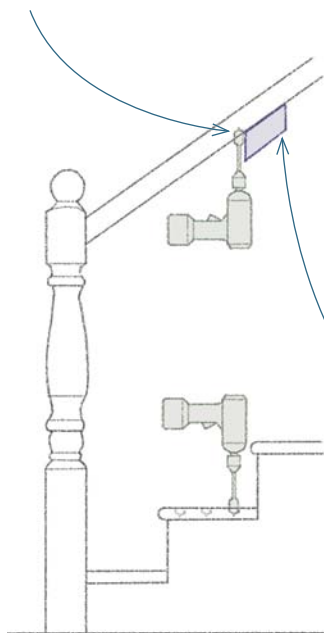

1 The hole at the bottom should be just a bit deeper than the dowel at the bottom of the baluster. Tape the bit to show when to stop drilling.

3 To get the holes in the underside of the top rail plumb, cut a guide block at an angle that equals the slope of the stairs (35° in this example).

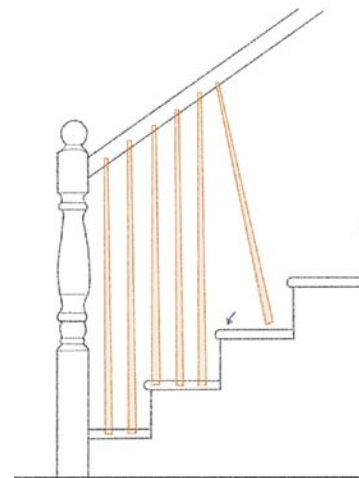

4 After drilling the holes, measure, cut, and install the balusters. Each of the three balusters for each step has to be a different length, so you can't set up a stop and rapidly cut all the balusters at once. Measure the distance between the tread and the underside of the rail and add $\frac{3}{4}$ in. After cutting the balusters, dry-fit them. If everything fits, put a dab of glue on the dowel at the bottom, and slide it up into the rail and down into the hole at the bottom. Drill a pilot hole and drive a single 3d finish nail at an angle at the top and bottom of each baluster.

● LAYING OUT AND INSTALLING THE BALUSTERS ON THE BALCONY

The layout of the balusters on the balcony should match the layout of the balusters along the stairs. On the stairs in this example, there were three balusters for every 10.07 in. of tread depth. The increment between the balusters, therefore, was 3.356 ($10.07 \div 3 = 3.356$). The increments along the balcony should be as close as possible to this increment.

STEP 1 Find the overall length of the layout

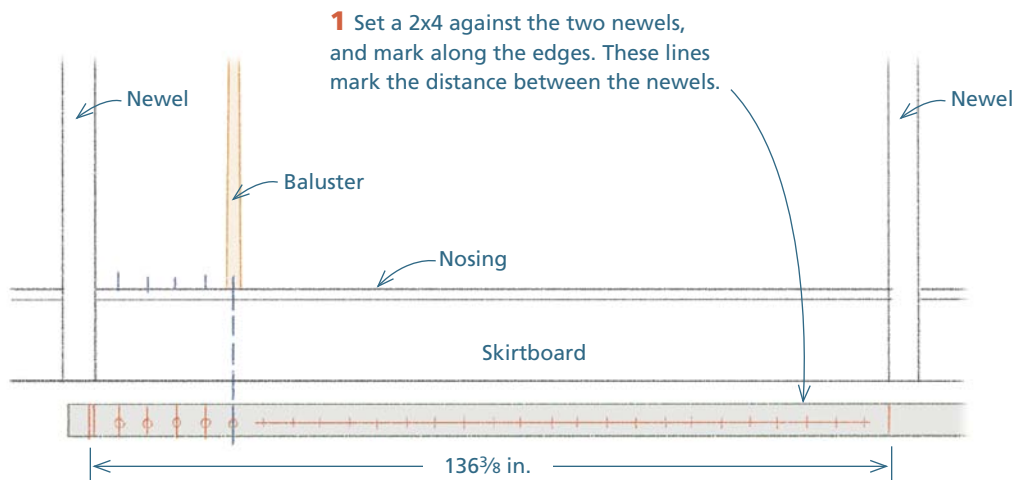

2 Mark a distance equal to half the circumference of the base of a baluster beyond each line. Since the balusters are $\frac{1}{4}$ in. thick at the base, you should measure $\frac{5}{8}$ in. out from each line. The distance between these marks, $136\frac{3}{8}$ in. in this example, is the overall length of the layout.

STEP 2 Find the number and size of the increments

Divide the overall length by the increment size along the stairs: $136.375 \div 3.356 = 40.63$. Round this number to find the number of increments (41). Divide the overall length by the number of increments to determine the size of the increments: $136.375 \div 41 = 3.3262195$.

STEP 3 Layout the centers of the balusters

Using one of the techniques described in "Three Ways to Divide a Space into Equal Increments" on p. 460, lay out 41 equal increments along the 136.375-in. length. The marks represent the centers of the balusters. Install the balusters using the techniques described on p. 498.

Conversions

FRACTIONS TO DECIMALS

.....

Divide numerator (upper number) by denominator (lower number).

Example: $\frac{3}{8}$ in. = 0.375 in. ($3 \div 8 = 0.375$)

DECIMAL PORTION OF AN INCH TO FRACTIONS OF AN INCH

.....

Multiply decimal by 16 and round to the nearest whole number to find the number of sixteenths; convert to eighths or quarters, if necessary.

Example: $0.352 = \frac{3}{8}$ in. ($0.352 \times 16 = 5.63$; 5.63 rounds to 6; $6/16 = \frac{3}{8}$)

INCHES TO CENTIMETERS

.....

Multiply inches by 2.54.

Example: 120 in. = 304.8 cm ($120 \times 2.54 = 304.8$)

CENTIMETERS TO INCHES

.....

Divide centimeters by 2.54.

Example: 84cm = 33.07 in. ($84 \div 2.54 = 33.07$)

Base-1 Proportions of Standard Roof Pitches

X-IN-12 ROOF PITCH	BASE	ALTITUDE	HYPOTENUSE
1-in-12	1	0.083	1.003
2-in-12	1	0.166	1.014
3-in-12	1	0.25	1.031
4-in-12	1	0.333	1.054
5-in-12	1	0.417	1.083
6-in-12	1	0.5	1.118
7-in-12	1	0.583	1.158
8-in-12	1	0.666	1.202
9-in-12	1	0.75	1.25
10-in-12	1	0.833	1.302
11-in-12	1	0.917	1.357
12-in-12	1	1.0	1.414
13-in-12	1	1.083	1.474
14-in-12	1	1.166	1.537
15-in-12	1	1.25	1.601
16-in-12	1	1.333	1.667
17-in-12	1	1.417	1.734
18-in-12	1	1.5	1.803
19-in-12	1	1.583	1.873
20-in-12	1	1.666	1.944
21-in-12	1	1.75	2.016
22-in-12	1	1.833	2.088
23-in-12	1	1.917	2.162
24-in-12	1	2.0	2.236

Backing Angles for Regular Hips and Valleys

PITCH OF HIP OR VALLEY	BACKING ANGLE
1-in-16.97	3.4°
2-in-16.97	6.7°
3-in-16.97	9.9°
4-in-16.97	12.9°
5-in-16.97	15.8°
6-in-16.97	18.4°
7-in-16.97	20.9°
8-in-16.97	23.1°
9-in-16.97	25.1°
10-in-16.97	26.9°
11-in-16.97	28.5°
12-in-16.97	30°
13-in-16.97	31.3°
14-in-16.97	32.5°
15-in-16.97	33.5°
16-in-16.97	34.5°
17-in-16.97	35.3°
18-in-16.97	36°
19-in-16.97	36.7°
20-in-16.97	37.3°
21-in-16.97	37.9°
22-in-16.97	38.4°
23-in-16.97	38.8°
24-in-16.97	39.2°

Base-1 Proportions of Regular Hip and Valley Pitches

X-IN-16.97 PITCH	BASE	ALTITUDE	HYPOTENUSE
1-in-16.97	1	0.059	1.002
2-in-16.97	1	0.118	1.007
3-in-16.97	1	0.177	1.016
4-in-16.97	1	0.236	1.027
5-in-16.97	1	0.295	1.043
6-in-16.97	1	0.354	1.061
7-in-16.97	1	0.412	1.082
8-in-16.97	1	0.471	1.106
9-in-16.97	1	0.530	1.132
10-in-16.97	1	0.590	1.161
11-in-16.97	1	0.648	1.192
12-in-16.97	1	0.707	1.225
13-in-16.97	1	0.766	1.260
14-in-16.97	1	0.825	1.296
15-in-16.97	1	0.884	1.335
16-in-16.97	1	0.943	1.374
17-in-16.97	1	1.002	1.415
18-in-16.97	1	1.061	1.458
19-in-16.97	1	1.120	1.501
20-in-16.97	1	1.179	1.546
21-in-16.97	1	1.237	1.591
22-in-16.97	1	1.296	1.637
23-in-16.97	1	1.335	1.684
24-in-16.97	1	1.414	1.732

Converting X-in-12 Roof Pitch to Degrees of an Angle

X-IN-12 PITCH	DEGREES
1-in-12	4.76°
2-in-12	9.46°
3-in-12	14.04°
4-in-12	18.43°
5-in-12	22.62°
6-in-12	26.57°
7-in-12	30.26°
8-in-12	33.69°
9-in-12	36.87°
10-in-12	39.81°
11-in-12	42.51°
12-in-12	45°
13-in-12	47.29°
14-in-12	49.40°
15-in-12	51.34°
16-in-12	53.13°
17-in-12	54.78°
18-in-12	56.31°
19-in-12	57.72°
20-in-12	59.04°
21-in-12	60.26°
22-in-12	61.39°
23-in-12	62.45°
24-in-24	63.43°

Converting X-in-16.97 Roof Pitch to Degrees

X-IN-16.97 PITCH	DEGREES
1-in-16.97	3.37°
2-in-16.97	6.72°
3-in-16.97	10.3°
4-in-16.97	13.26°
5-in-16.97	16.42°
6-in-16.97	19.47°
7-in-16.97	22.42°
8-in-16.97	25.24°
9-in-16.97	27.94°
10-in-16.97	30.51°
11-in-16.97	32.95°
12-in-16.97	35.27°
13-in-16.97	37.45°
14-in-16.97	39.52°
15-in-16.97	41.47°
16-in-16.97	43.31°
17-in-16.97	45.05°
18-in-16.97	46.69°
19-in-16.97	48.23°
20-in-16.97	49.69°
21-in-16.97	51.01°
22-in-16.97	52.35°
23-in-16.97	53.58°
24-in-16.97	54.74°

Miter and Bevel Settings for Crown Molding

52/38° CROWN MOLDING			45/45° CROWN MOLDING	
Angle between Walls	Miter Setting	Bevel Setting	Miter Setting	Bevel Setting
67	42.93	41.08	46.89	36.13
68	42.39	40.79	46.35	35.89
69	41.85	40.50	45.81	35.64
70	41.32	40.20	45.28	35.40
71	40.79	39.90	44.75	35.15
72	40.28	39.61	44.22	34.89
73	39.76	39.30	43.70	34.64
74	39.25	39.00	43.18	34.38
75	38.74	38.69	42.66	34.12
76	38.24	38.39	42.15	33.86
77	37.74	38.08	41.64	33.60
78	37.24	37.76	41.13	33.33
79	36.75	37.45	40.62	33.07
80	36.27	37.13	40.12	32.80
81	35.79	36.81	39.62	32.53
82	35.31	36.49	39.13	32.25
83	34.83	36.17	38.63	31.98
84	34.36	35.85	38.14	31.70
85	33.90	35.52	37.66	31.42
86	33.43	35.19	37.17	31.14
87	32.97	34.86	36.69	30.86
88	32.52	34.53	36.21	30.57
89	32.07	34.20	35.74	30.29

52/38° CROWN MOLDING			45/45° CROWN MOLDING	
Angle between Walls	Miter Setting	Bevel Setting	Miter Setting	Bevel Setting
90	31.62	33.86	35.26	30.00
91	31.17	33.53	34.79	29.71
92	30.73	33.19	34.33	29.42
93	30.30	32.85	33.86	29.13
94	29.86	32.51	33.40	28.83
95	29.43	32.17	32.94	28.54
96	29.00	31.82	32.48	28.24
97	28.58	31.48	32.02	27.94
98	28.16	31.13	31.58	27.64
99	27.74	30.78	31.13	27.34
100	27.32	30.43	30.68	27.03
101	26.91	30.08	30.24	26.73
102	26.50	29.73	29.80	26.42
103	26.09	29.38	29.36	26.12
104	25.69	29.02	28.92	25.81
105	25.29	28.67	28.48	25.50
106	24.89	28.31	28.05	25.19
107	24.49	27.95	27.62	24.87
108	24.10	27.59	27.19	24.56
109	23.71	27.23	26.77	24.24
110	23.32	26.87	26.34	23.93
111	22.93	26.51	25.92	23.61
112	22.55	26.15	25.50	23.29

52/38° CROWN MOLDING			45/45° CROWN MOLDING	
Angle between Walls	Miter Setting	Bevel Setting	Miter Setting	Bevel Setting
113	22.17	25.78	25.08	22.97
114	21.79	25.42	24.66	22.65
115	21.42	25.05	24.25	22.33
116	21.04	24.68	23.84	22.01
117	20.67	24.31	23.43	21.68
118	20.30	23.94	23.02	21.36
119	19.93	23.57	22.61	21.03
120	19.57	23.20	22.21	20.70
121	19.20	22.83	21.80	20.38
122	18.84	22.46	21.40	20.05
123	18.48	22.09	21.00	19.72
124	18.13	21.71	20.61	19.39
125	17.77	21.34	20.21	19.06
126	17.42	20.96	19.81	18.72
127	17.06	20.59	19.42	18.39
128	16.71	20.21	19.03	18.06
129	16.37	19.83	18.64	17.72
130	16.02	19.45	18.25	17.39
131	15.67	19.07	17.86	17.05
132	15.33	18.69	17.48	16.71
133	14.99	18.31	17.09	16.38
134	14.65	17.93	16.71	16.04
135	14.30	17.55	16.32	15.70

52/38° CROWN MOLDING			45/45° CROWN MOLDING	
Angle between Walls	Miter Setting	Bevel Setting	Miter Setting	Bevel Setting
136	13.97	17.17	15.94	15.36
137	13.63	16.79	15.56	15.02
138	13.30	16.40	15.19	14.68
139	12.96	16.02	14.81	14.34
140	12.63	15.64	14.43	14.00
141	12.30	15.25	14.06	13.65
142	11.97	14.87	13.68	13.31
143	11.64	14.48	13.31	12.97
144	11.31	14.09	12.94	12.62
145	10.99	13.71	12.57	12.28
146	10.66	13.32	12.20	11.93
147	10.34	12.93	11.83	11.59
148	10.01	12.54	11.46	11.24
149	9.69	12.16	11.09	10.89
150	9.37	11.77	10.73	10.55
151	9.05	11.38	10.36	10.20
152	8.73	10.99	10.00	9.85
153	8.41	10.60	9.63	9.50
154	8.09	10.21	9.27	9.15
155	7.77	9.82	8.91	8.80
156	7.46	9.43	8.55	8.45
157	7.14	9.04	8.19	8.10
158	6.82	8.65	7.83	7.75

52/38° CROWN MOLDING			45/45° CROWN MOLDING	
Angle between Walls	Miter Setting	Bevel Setting	Miter Setting	Bevel Setting
159	6.51	8.26	7.47	7.40
160	6.20	7.86	7.11	7.05
161	5.88	7.47	6.75	6.70
162	5.57	7.08	6.39	6.35
163	5.26	6.69	6.03	6.00
164	4.95	6.30	5.68	5.65
165	4.63	5.90	5.32	5.30
166	4.32	5.51	4.96	4.94
167	4.01	5.12	4.61	5.59
168	3.70	4.72	4.25	4.24
169	3.39	4.33	3.90	3.89
170	3.08	3.94	3.54	3.53
171	2.77	3.54	3.19	3.18
172	2.47	3.15	2.83	2.83
173	2.15	2.75	2.48	2.47
174	1.85	2.36	2.12	2.12
175	1.54	1.97	1.77	1.77
176	1.23	1.58	1.41	1.41
177	0.92	1.18	1.06	1.06
178	0.62	0.79	0.71	0.71
179	0.31	0.39	0.35	0.35

Index

A

- Air
 - basic facts, 290
 - sealing, 306
 - vapor (see Vapor)
- Asphalt-shingle roofs
 - components of, 189
 - cutting and fitting shingles, 204–5
 - flashing (see Flashing)
 - gauged roofing hammer, use of, 201
 - installing, 197, 199–201
 - layout, 190
 - horizontal courses, 190–91
 - increment for snapping chalklines, 190
 - maintaining the offset when crossing obstructions, 195
 - the offset, 192–93, 196
 - undersize tabs along the rakes, avoiding, 194
 - low slope advisory for, 186
 - minimum pitch for, 187, 189
 - obstacles, shingling around, 218–20
 - ridge and hip caps, installing, 226–29
 - ridge vents, installing, 229–30
 - three patterns for shingling, 202–3
 - underlayment and drip edge, 197–99
 - valleys, options for shingling, 215–17
- Attic trusses, 145

B

- Backing, 52, 88, 91, 119
- Backing bevels, 104

- Balustrades
 - exterior, 467
 - level sections, cutting, assembling, and installing, 470–73
 - level sections, laying out, 468–69
 - posts, safe cutting of, 471
 - sloped sections, cutting, assembling, and installing, 477–78
 - sloped sections, laying out, 474–76
 - interior, 496
 - balusters, installing, 498
 - balusters on the balcony, laying out and installing, 499
 - laying out a code-complying, 496–97
- Baseboard molding. *See* Trim, baseboard
- Basement bearing walls, 60
- Basements
 - allowing concrete to dry, 294, 296
 - controlling water, 49, 282–83
 - excavating, 8
 - laying out, 12–13, 16–18, 20–23
 - rigid foam sheets on walls, 294, 296
 - vapor barriers and capillary breaks, 295–96
- Bathrooms, blocking needed for, 88–89
- Batter boards
 - foundation layout, use in, 18, 20, 21, 27, 28, 29, 30, 31
 - non-right triangles and curves, use in laying out, 33
 - stringlines, use with, 25

- using additional when adding rectangles to the foundation, 32

- Blocking, 52, 67, 88–91, 237
- Bridging, 67
- Building codes
 - fire protection, 52
 - frost line, bottom of footings below, 8
 - roof sheathing, performance standards for, 179
 - stairs, dimensions of, 447
- Building inspectors
 - engineered lumber used for floor systems, 68
 - soil, advice on, 7
- Butt joint, 404
- Butt-marking gauge, 367

C

- Cabinets
 - appliances, leaving room for, 436
 - check clearances and allowance for the finished floor, 435
 - cutting and fitting filler strips, 441
 - installing base, 441
 - installing wall, 436, 438–40
 - layout, 436, 437
 - remove drawers and doors, 436
 - screws for hanging, 438
 - supporting upper, 439
- Cantilever trusses, 146
- Ceilings
 - blocking needed for, 91
 - controlling vapor, 303–4
 - drywall (see Drywall)
 - installing under a hip roof, 119

- joists for, 93–94, 118
 - large openings in, 93
 - laying out on top plates, 92–93
 - solid-sawn tongue-and-groove plank paneling, 334–35
 - Ceramic tile
 - cutting, 350
 - cutting backer board, 345
 - grouting and cleaning, 352–53
 - installing backer board on floors, 346
 - installing backer board on walls, 345
 - laying out, 347–48
 - membranes used with, 346
 - setting, 349–51
 - tile floor, components of, 344
 - underlayment under, 349
 - Chalklines, 190
 - Chimneys
 - masonry, building a cricket and flashing, 222–24
 - stone, flashing, 224–25
 - Circular saws, guide for using, 364
 - Climate
 - controlling vapor in ceilings based on, 303–4
 - controlling vapor in walls based on, 299–302
 - zones, 297
 - Collar ties, 99
 - Composite panels, 179
 - Compound angles, cutting, 104
 - Compound miter joints, 404, 422–23
 - Concrete
 - admixtures, 47
 - curing, 43–44
 - estimating volume, 45, 46
 - floors, letting moisture exit from, 294
 - forms, 44–45, 452
 - forms, aligning and bracing, 46
 - ingredients, 41
 - poured for exterior stairs, 453
 - poured for foundation walls, 44–47
 - slump, 42, 453
 - stairs, 449–53
 - strengths and weaknesses, 41
 - subcontractor, hiring a, 47
 - water and, 42–43
 - Concrete block
 - building corners, 37
 - foundation walls, 34–40
 - fudging the layout, 36
 - laying to a line, 38
 - mortar, 38, 39
 - rebar, cleanouts, and grout, 40
 - troweling technique, 39
 - unit spacing, 36
 - Condensation, preventing with insulation, 306–7
 - Conversions between units of measure, 500
 - Coped joints, 405, 419
 - Corners
 - houses without trimmed corners, 260
 - installing trim, 257–59
 - Cornices
 - framing a return, 173
 - returns, building structurally sound, 171
 - return with a hip roof, 176
 - return with a shed roof, 174–75
 - Corrugated wall ties, 275
 - Crawlspaces
 - controlling vapor, 294–95
 - controlling water, 49, 283
 - excavating, 8
 - laying out, 26–31
 - Cricket, building and flashing a, 222–24
 - Crown molding. *See* Trim, crown molding
- ## D
- Damp-proofing and waterproofing, 285–87
 - Deck ledgers, flashing, 251
 - Door-boring jig, 373
 - Doors, 354
 - arched, flashing tops of, 244–46
 - bifold, 390
 - framing the opening and installing the jamb, 390–93
 - installing casing and hardware, 393–94
 - installing doors, 394–95
 - boring locksets, 372–73
 - casings and cabinets, blocking needed for, 90
 - fitting new doors to existing openings, 361–63, 365–68, 370–71, 374
 - flashing sides and top of, 243
 - flashing wide doorsills, 244
 - foam sealing around, 305
 - hanging French double doors, 375–82
 - hanging prehung, 355–61

- hollow core, concerns
 - regarding, 362
 - installing, 241–42
 - installing casing, 397–99, 402–3
 - layout of rough openings for, 74, 75 (*see also* Headers)
 - mortising hinges, latch plates, and strikes, 369
 - openings, installing
 - underlayment around, 234–35
 - plumbing door shims, 359
 - pocket, 383
 - finishing the wall and installing trim, 387–89
 - framing the opening, 383–85
 - hanging the door, 386
 - important things to know about, 384
 - screws, using, 386
 - preformed jambs, 394
 - prehung, styles of, 355
 - rough openings, adjusting, 357
 - securing on edge, 366
 - Dormer, doghouse, 136–41, 218–19
 - Drainage boards, 286–88
 - Drip edge, 189, 197, 199
 - Drop-top gable-end trusses, 145, 166
 - Drywall
 - basics of, 311–12
 - carrying, 315
 - cutting
 - around electrical boxes and small fixtures, 320–22
 - lipstick, marking electrical boxes and
 - small fixtures with, 320
 - special-purpose tools for, 318
 - tools and techniques for, 316–17, 319
 - using a drywall router, 322
 - fastening systems, 323
 - finishing
 - extra coats to reduce sanding, 334
 - first coat, 328–29
 - inside corners, 330
 - materials, 325
 - second coat, 330–31
 - third coat, 332–33
 - working with mud, 332–34
 - hanging, 314
 - arched openings, 324
 - ceilings and walls, 324, 326–27
 - corner beads, installing, 324
 - expansion gap for flooring, allowing for, 339
 - tolerances, 314
 - ordering, estimates for, 314
 - types of matched to the job, 313
- E**
- Eaves
 - begin planning for, 155
 - cross blocks or soffit joists, installing, 163
 - cutting tails in place, procedure for, 158–60
 - ledger, installing the, 163
 - precut rafter and truss tails, adjustments to, 157
 - subfascia, advantages of using, 162
 - subfascia, procedure for installing, 160–61, 163
 - trim, installing, 252–54
 - Elastomeric membrane, 187
 - Elevations. *See* Leveling instruments
 - End grain, sealing, 252
 - Engineered lumber (EL), 55, 68–70, 485
 - Exterior trim
 - clad-wood and vinyl windows, 259, 261–62
 - corners, 257–59
 - corners, houses without trimmed, 260
 - eaves, 252–54
 - installing, 252
 - rakes, 254–57
- F**
- Fascia, 254
 - Fire, protection from, 52
 - Fire blocking, 88
 - Flashing, 189
 - apron, 209
 - back-piece, 212–13
 - deck ledgers, 251
 - drip-cap, 243, 247, 248, 249, 262
 - installing, 206–8
 - lapped siding, weaving into, 266
 - lead anchors, making, 222
 - masonry chimneys, 222–24
 - masonry siding systems, 274
 - masonry walls, 220–22
 - materials for, 206

- as primary and secondary barriers shedding water, 242
 - seams between shingles and, 208
 - sills, materials for, 240
 - step, 210–11
 - stone chimneys, 224–25
 - valleys, treatments of, 213–15
 - windows and doors, 239–50, 262
 - Z-, 273
- Floors, 54
- carpeting, 338
 - ceramic tile (*see* Ceramic tile)
 - engineered lumber, use of, 68–70
 - floating floor systems, 341
 - floor nailer, use of, 341
 - installing girders or basement bearing walls, 59–60
 - installing joists, 61–65
 - installing sheathing, 65–66
 - mudsills, 54, 56–59
 - sealing perimeter from air infiltration, 299
 - sheet vinyl, 342–43
 - timing of installation, 336
 - wood, installation of, 336–37, 339–41
- Footings, 8–10
- digging, 28–30
 - forms for, 21
 - frost lines and depth of, 23
 - pouring, 22, 30–31
 - rebar set in, 40
- Foundations, 6
- backfilling, 289
 - controlling vapor and capillary action, 293–94
 - damp-proofing and waterproofing, 285–87
 - drainage boards, 286–88
 - excavating, 8–10, 11, 289
 - footings, 8–10
 - grading around, 12, 279–80
 - layouts, 11
 - basement, 12–13, 16–18, 20–23
 - beyond rectangular floor plans, 32–33
 - crawl spaces, 26–31
 - curves, 33
 - mudsill, making adjustments in, 58
 - managing water, 279, 284–89
 - soil, assessing and preparing, 7, 9
- Foundation walls
- concrete block, 34–40
 - permanent wood foundations (PWFs), 48–49
 - poured concrete, 41–47
 - systems used for, 34
- Framing a house, general considerations for anticipating subsequent work, 52
- balloon vs. platform frame, 53–54
 - durability, 51
 - fire protection, 52
 - framing circular shapes, 97
 - functions of the frame, 50
 - loads, 51
 - materials used in platform frames, 55
- French double doors, 375–82
- Frieze, 254, 257
- Frost heave, 8, 448
- G**
- Gable-end trusses, 145
 - Geometry of building a house
 - backing angles for regular hips and valleys, 502
 - base-1 proportions of regular hip and valley pitches, 503
 - base-1 proportions of standard roof pitches, 501
 - converting X-in-12 roof pitch to degrees of an angle, 504
 - converting X-in-16.97 roof pitch to degrees of an angle, 505
 - dropped gable-end wall, lay out of, 168
 - gable roof, math and layout in building a, 105–7
 - hip rafters, 122
 - jack rafters, 128, 135
 - pitch, 101, 104
 - right triangles, working with, 19
- Girders, 59–60, 69
- Girder trusses, 146
- Glulams, 55
- Guardrails. *See* Stairs, rails
- Guide for saw or router, 364
- H**
- Handrails. *See* Stairs, rails
- Headers
- for arched openings, 97
 - fabricating bearing, 77
 - fabricating nonbearing, 78
 - height of, 80, 86
 - measuring the lengths of, 78
 - trimmer studs for, 79
- Hip caps, 227–29
- Hips, roofing. *See* Roofs, hip
- Hip trusses, 147
- Housewraps, drainable, 236

I

Insulation

- air sealing and, 306
- controlling vapor, 297, 305–7
- IC-rated recessed lights, 304

J

Jambs, preformed, 394

Joints for trim carpentry, 404–5

Joists

ceiling

- installing, 94, 118, 119
- laying out on top plates, 92
- needs of plumbers and electricians, anticipating, 93
- pitch of the rafters, cutting ends to conform to, 94

floor

- details of installation, 67
- high spots in the foundation and, 57, 64, 67
- installing, 65
- installing rim joists, 64
- layout on the mudsill, 62–63
- sort and crown material, 61
- wood I-joists, 55, 70

roof, 99

Jumping jack compactor, 10

L

Laser levels, 14, 151

Layouts

- balustrades, 468–69, 496–97
- base-1 triangles, using, 107

- cabinets, 437
- center of a space, finding the, 73
- ceramic tile, 347–48
- conversions between units of measure, 500
- crown molding, 423–25
- cumulative gain or loss in measurement, avoiding, 62
- dividing a space into equal increments, 460–61
- floors (*see* Floors)
- foundations (*see* Foundations, layouts)
- gable roof, geometry of building a, 105–7 (*see also* Roofs, gable)
- leveling instruments, use of, 14–15 (*see also* Leveling instruments)
- math and, difference between, 105
- octagons, 97
- problems in, splitting the difference when facing, 72
- rafters (*see* Rafters; Roofs)
- right triangles, working with, 19
- rough openings for doors and windows, 75
- slant-rule trick, 265, 460
- stringlines, setting up, 24–25 (*see also* Stringlines)
- walls (*see* Walls)

Leveling instruments

- aligning trusses with, 151
- checking for level, 56
- foundation layout and, 17, 18, 26, 27, 29, 31, 32, 33
- use of, 14–15

Lighting, IC-rated recessed lights in insulated ceilings, 304

Loads, 51, 100

Lock mortiser, 373

Lumber

- engineered, advantages of, 68, 485
- engineered for floor systems, girders, joists, and trusses, 69–70
- nominal sizing of, 254
- solid-sawn and engineered, 55, 69
- solid-sawn for sheathing, 178

M

Masonry

- foundation walls, used for, 34–40
- siding, 273–75
- strengths and weaknesses of, 35

Master and split trusses, 147

Metal rafter/truss ties, 156

Miter cuts, 102

Miter joint, 404

Miter returns, safely cutting, 408

Miter saws, 400–401

Modular coordination, 52

Moisture. *See* Vapor; Water

Mortar, 38, 39

Mudsills, 54, 56–59, 62–63

O

Offset stakes, 13, 16, 17, 18, 20

Optical levels, 14. *See also* Leveling instruments

Oriented strand board (OSB), 55, 177, 179

P

- Paneling, plank and plywood, 334–35
- Penetrometer, 9
- Perimeter drains, 288
- Pipe flanges
 - cutting shingles around, 205
 - installing flashing around, 206–7
- Pitch
 - controlling the flow of water with, 187
 - converting X-in-12 roof pitch to degrees of an angle, 504
 - converting X-in-16.97 roof pitch to degrees of an angle, 505
 - degrees of an angle and, conversion between, 101, 104
 - designation of, 101
 - low slope advisory for use of shingles, 186
 - low-sloped and steep-sloped roofing systems, 185–89
 - measuring roof, 188
 - minimum for asphalt-shingled roofs, 187, 189
- Pitch triangles, 96
- Plywood, 55, 178

R

- Rafter jigs, 108, 120, 126, 130, 157, 255
- Rafters
 - attachment to bearing walls, 156
 - barge, 164–65, 170, 172, 175
 - common, 99, 115–16, 117, 118, 121, 131, 134, 139

- cornice, 175
 - cuts required for framing, 102, 104
 - gable roof, lay out and cutting, 111–12
 - hip, 99, 115, 116, 118, 122–26
 - hip roof, lay out and cutting, 115–29
 - installing, 114, 121
 - jack, 99, 104, 117, 118, 128–29, 135, 141
 - tails, 99, 113, 133, 157–58
 - trusses vs., 103
 - valley, 99, 132–34
 - verge, 166, 168–69, 172
- Rainscreens, 237–38
- Rakes
 - begin planning, 155
 - cantilevered overhang, building
 - cantilevered rake, framing, 169–70
 - dropped gable-end wall, laying out and building, 167
 - notched verge rafters, installing, 168–69
 - returns, framing, 172–73
 - venting the first bay, 170
- cutting shingles for, 205
- flashing the underside of, 211
- installing trim, 254–57
- ladder-type, building, 164–65, 172
- returns, building structurally sound, 171
- returns, framing, 172–73

Returns

- building structurally sound, 171
- cornice
 - framing, 173
 - with a hip roof, 176

- with a shed roof, 174–75
 - rake, framing a, 172–73
- Ridge caps, 189, 226–29
- Ridges, 99, 109–10, 118, 120, 131–32
- Ridge vents, 229–30
- Roofing, 184
 - asphalt-shingle (*see* Asphalt-shingle roofs)
 - final inspection, 230
 - protecting fasteners and seams on steep-sloped roofs, 188–89
 - ruler to use on a roof deck, 191
 - single-ply systems, installing, 186
 - two basic systems of, 185
 - low-sloped roofs, 185–86
 - steep-sloped roofs, 185, 187–89
 - valleys (*see* Valleys)
- Roofing felt, 199. *See also* Underlayment
- Roofs
 - asphalt-shingle (*see* Asphalt-shingle roofs)
 - built-up, 185
 - challenges of building, 98, 127
 - doghouse dormer, 136–41
 - eaves (*see* Eaves)
 - flat-seamed metal, 185
 - gable, 105
 - lay out, cut and assemble, 109–13
 - math and the layout of, 105–7, 501
 - with trusses, 154–55
 - getting hips and valleys in plane with the roof, 127
 - hip, 115
 - backing angles for regular hips and valleys, 502

- base-1 proportions of
 - regular hip and valley pitches, 503
 - ceiling joists and backing under, 119
 - common rafter lay out and installation, 121
 - cut and install the ridge, 120
 - hip rafter assembly and installation, 126
 - hip rafter lay out and cutting, 122–25
 - jack rafter lay out and installation, 128–29
 - key measurements taken off top plates, 118
 - lay out rafter locations, 115–17
 - loads carried by, 100
 - parts of stick-built, 99
 - pitch of, 101, 104 (*See also* Pitch)
 - rafters vs. trusses, 103
 - rain, collecting and draining, 281
 - rakes (*see* Rakes)
 - sheathing, 176
 - installing, 177, 180–81
 - materials for, 178–79
 - single-ply, 186
 - spray polyurethane foam, 186
 - structural approaches to, 100–101
 - trusses (*see* Trusses)
 - valley plates, 140
 - with valleys, 130
 - install valley rafters, 134
 - lay out, cut, and install jack rafters, 135
 - lay out and and cut valley rafters, 133
 - lay out and install ridges and common rafters, 131–32
 - lay out common rafters for area above the header, 134
 - prep material for valleys, 132
- Routers
- guide for using, 364
 - mortising hinges, latch plates, and strikes, 369
- Rule of Proportion, 447
- S**
- Safety
- cap nails, picking up, 195
 - concrete delivery trucks, 41
 - cutting miter returns, 408
 - cutting posts, 471
 - fire blocking, 88, 237
 - frame, as a function of, 51–52
 - raising walls on a windy day, 84
 - securing planks set across joists, 111
 - trenches and basement excavations, 31
 - unbanding packages of trusses, dangers of, 149
- Scarfed joint, 405
- Scissor trusses, 145
- Sheathing
- bad spots in tongue or groove, cutting out, 66
 - installing floor, 65–66
 - installing roof, 177, 180–81
 - lay out from the top, 181
 - performance standards for roof, 179
 - for roofs, 176, 178–79
- Sheetrock. *See* Drywall
- Siding
- adjusting the size of courses, reasons for, 264
 - installing board-and-batten, 267
 - interlocking systems, 269
 - lapped systems with
 - horizontal courses, 263–66, 276
 - lapped systems with vertical courses, 266–67, 277
 - most vulnerable spot, protection at, 276–77
 - movement from the weather, allowing for, 270–71
 - nailing lapped, 267, 271
 - plywood panel, 269, 272–73, 277
 - profiles of, 263
 - stucco and masonry, 273–75
 - vinyl trim, 268
 - weaving flashing into courses of, 266
- Slabs
- excavation for, 8
 - managing water under, 282–83, 293
- Slant-rule trick, 265, 460
- Slotted truss anchors, 156
- Soffit, 253, 255
- Soil
- assessing and preparing, 7
 - testing, 9
- Splice joint, 405
- Staircases, blocking needed for, 90
- Stair jig, 458
- Stairs, 442
 - balustrades (*see* Balustrades)
 - exterior, 448
 - interior, 479
 - landings, laying out, 484
 - newels, cutting notches in, 491
 - newels, installing, 487–89

- risers and treads,
 - installing, 493–95
- riser/tread combination,
 - calculating, 480–81
- skirtboards, installing, 490, 492
- stairwell, calculating
 - length of, 482
- stairwell, laying out, 479–80
- stringers, fastening, 485–86
- stringers, laying out, 483
- key dimensions of, 445–46
- masonry, 448
- parts of, 443
- poured concrete, 449–53
- rails
 - graspable handrail inside a guardrail, 467
 - key dimensions of, 446
- riser/tread combinations,
 - choosing, 447, 450
- stringers, materials for, 485
- terminology of building, 444
- wood exterior
 - design considerations, 454
 - footing, digging, 463–64
 - grade, measuring difference in, 456
 - landing and posts,
 - positioning and pouring concrete for, 465–66
 - rise, calculating adjusted total, 457
 - rise, estimating total, 455
 - risers, choosing size for, 457
 - risers and treads, installing, 467
 - stringers, attaching to the deck, 455
 - stringers, cutting, 463
 - stringers, dividing into equal parts, 459
 - stringers, installing, 464–65

- stringers, laying out, 454
- stringers, marking risers and treads on, 462
- top and bottom stairs, laying out, 462
- Story poles/sticks
 - balustrades, layout of, 497
 - cement block corners, use in building, 37
 - rafters, layout of, 112, 121, 134
 - siding, use in installing, 265
- Stringlines
 - aligning trusses with, 151
 - checking layout of
 - foundation walls, 23
 - footings, layout of, 29, 30
 - laying block walls, 37, 38
 - laying out angles that are not 90°, 33
 - laying out foundations, 27, 28
 - layout of foundation walls, 31
 - poured concrete walls, layout of, 46
 - setting up, 24–25
- Structural composite lumber (SCL), 55, 69–70
- Studs
 - cripple, 80
 - king, trimmer, and cripple for rough openings, 74
 - trimmer, 79
- Subfascia, 160–61, 162, 163, 164, 169, 175

T

- Toenails, 156
- Treated wood, 51
- Trim, 396–97

- baseboard
 - carpeted floors, caution regarding, 414
 - cutting and fitting, 414–18
 - expansion gap for
 - flooring, allowing for, 339
 - installing, 410
 - planning and preparing for, 411
 - raising off the subfloor, 413
- chair rail molding, 420
- coped joints, fine-tuning, 419
- crown molding, 421
 - attaching, 431
 - cutting and fitting inside corners, 426–28
 - cutting compound miters, 422–23
 - fitting outside corners on the flat, 430–31
 - fitting outside corners with the nesting method, 429
 - laying out, 423–25
 - measuring and cutting inside corner to outside corner, 428
 - miter and bevel settings for, 506–10
 - oblique angles, running around, 434
 - order of installation, 421–22
- door casing, 397–99, 402–3
- exterior (*see* Exterior trim)
- inside-to-inside
 - measurements, tip for making, 415, 428
- miter returns, safely cutting, 408
- nailing schedule, 405
- oblique (not right) angles, methods for, 432–33

studs, locating, 416
window, 406–9

Trim carpentry

joints for, 404–5
miter vs. bevel cuts, 405
six rules of, 412–13

Trusses, 55, 142–43

aligning during installation, 151
alterations of, need to avoid, 144
attachment to bearing walls, 156
braces: ground, temporary, and permanent, 152–53, 155
drop-top gable-end trusses, 145, 166
as a framework of triangles, 143
gable roof built with, 154–55, 157
moving and hoisting, 150
options for, 145–47
ordering, 148
organizational oversight of design and manufacture, 144
parallel-chord floor trusses, 70
rafters vs., 103
storing and handling, 148–49
unbanding packages of, dangers from, 149

Truss Plate Institute, 144

U

Underlayment

under ceramic tile, 349
under roofing shingles, 189, 197–98, 199
under siding, 234–35 (see also Weather-resistive barriers (WRBs))

V

Valley plates, 140

Valleys

cutting shingles for, 205
flashing in, 213–15
framing (see Roofs, with valleys)
options for shingling, 215–16
shingling when roofs have different pitches, 217

Valley trusses, 146

Vapor

air transport of, 290–91
controlling in foundations and basements, 293–97
controlling in wood-framed assemblies, 297–308
in ceiling assemblies, 303–4
in framed floor systems, 298–99
in framed walls, 299–302
controlling transmission of, 233, 290
diffusion through building materials, 291–92
permeability of building materials, 298
permeable and impermeable materials, 292
using insulation to control, 297, 305–7

Ventilation

with asphalt-shingle roofs, 189
ridge vents, 229–30

Vents

cutting shingles around, 205
installing flashing around, 206–7

Vix bits, 370

W

Wallboard. See Drywall

Walls

blocking and backing, 88–91
ceramic tile (see Ceramic tile)
cutting shingles to fit against, 205
dropped gable-end, 166, 167
drywall (see Drywall)
exterior
assembling, 81–82
bearing headers, 77
cripple studs and windowsills, 80
fabricated corners, 76
fabricating components of, 76–80
laying out details on plates, 73–74
laying out locations of, 71–72
nonbearing headers, 78
raising and bracing, 84–85
sheathing, 83
T-intersections, 76
trimmer studs and bearing headers for doors, 79
flashing masonry, 220–22
framing circular shapes, 97
gable-ends
framing, 95–96
pitch triangle, using a, 96
installing flashing at the roof/wall juncture, 208
interior
layout, details to remember during, 86
lifting and installing, 87
paneling, plank and plywood, 334–35
second top plate, installing the, 87
vapor control in, 299–302, 307

- Water
 - in the air (*see* Vapor)
 - controlling, foundations and, 48–49
 - damp-proofing and waterproofing
 - foundations, 285–87
 - durability of frame
 - construction and, 51
 - inside siding, 236
 - managing groundwater, 279, 282–89
 - managing outside the foundation, 284–89
 - managing surface, 279–81
 - managing under a slab or basement, 282–83
 - most vulnerable spot, protection at, 276–77
 - movement in the ground, 282
 - perimeter drains, 288
 - primary and secondary barriers for shedding, 242
 - rain from the roof, collecting and draining, 281
 - shedding rainwater, 232–33
 - sump crock, setting a, 284–85
 - See also* Vapor
- Weather-resistive barriers (WRBs), 234–37
 - flashing sides and tops of doors and windows, 243, 245–50, 261–62
 - stucco and masonry siding systems and, 273–74
- Weatherstripping, trimming windows, 261
- Windows
 - arched, flashing tops of, 244–46
 - clad-wood and vinyl, installing trim around, 259, 261–62
 - flashing bottom of the opening, 239
 - flashing sides and top of, 243
 - foam sealing around, 305
 - installing, 241–42
 - installing trim, 406–9
 - layout of rough openings for, 74, 75 (*see also* Headers)
 - octagonal, flashing tops of, 248–49
 - openings, installing underlayment around, 234–35
 - round, flashing tops of, 250
 - sills, materials for flashing, 240
 - slope-topped, flashing tops of, 247
- Windowsills, 80
- Wood I-joists, 55, 70
- Wood Truss Council of America, 144

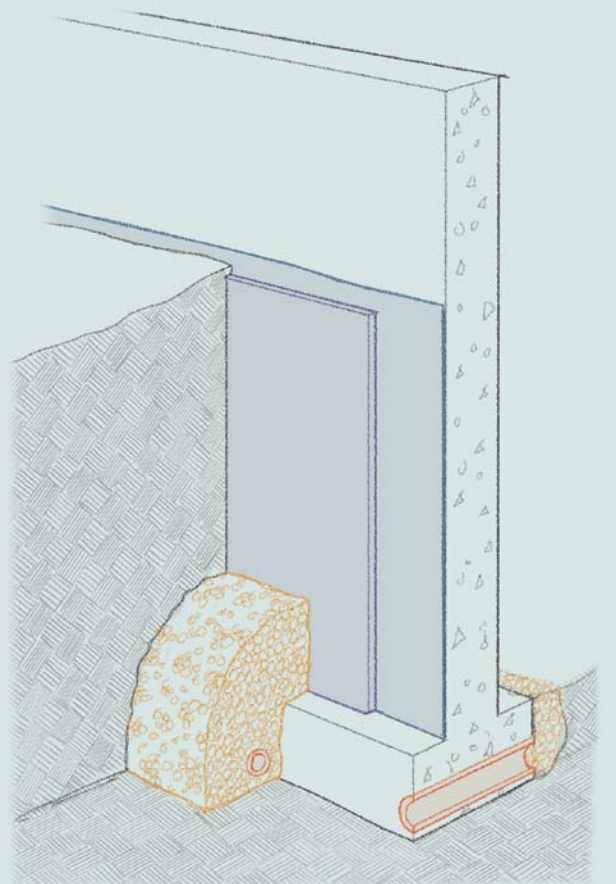
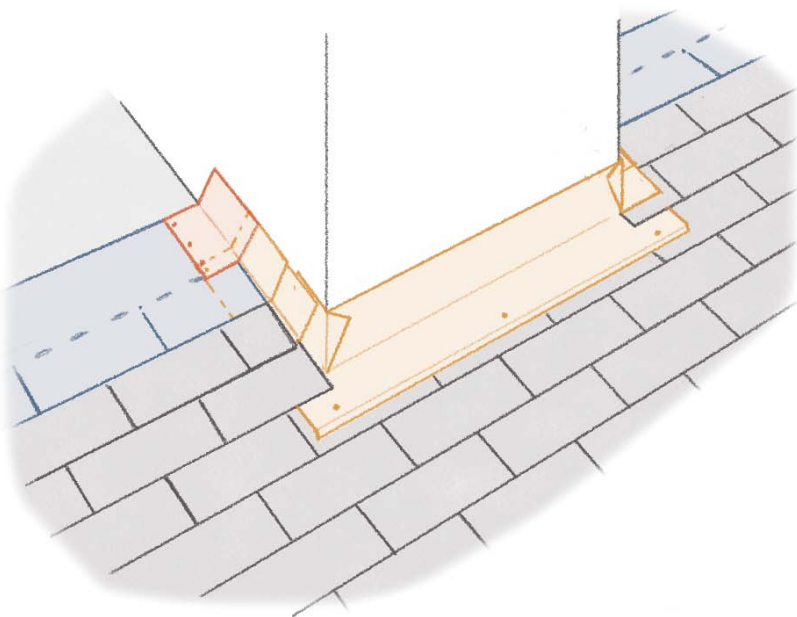
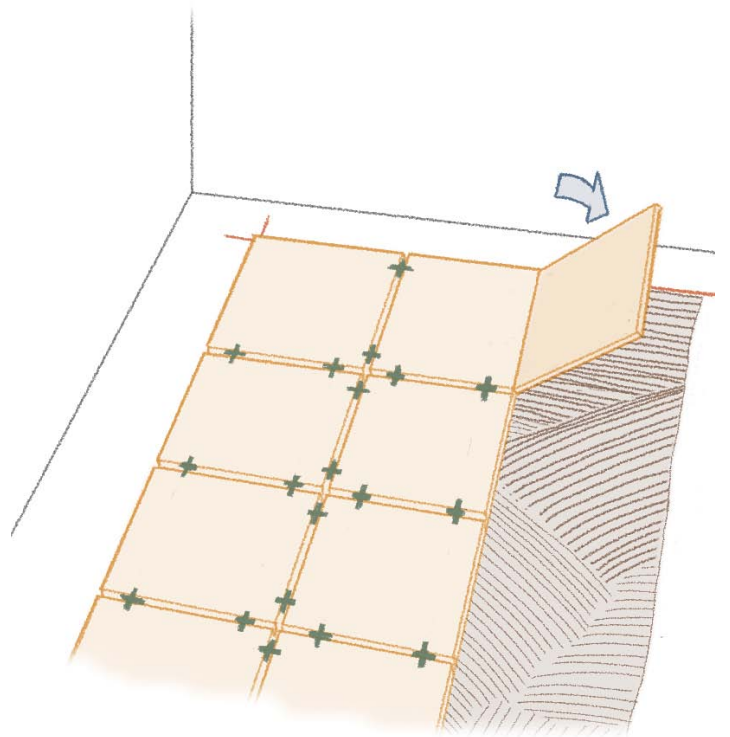
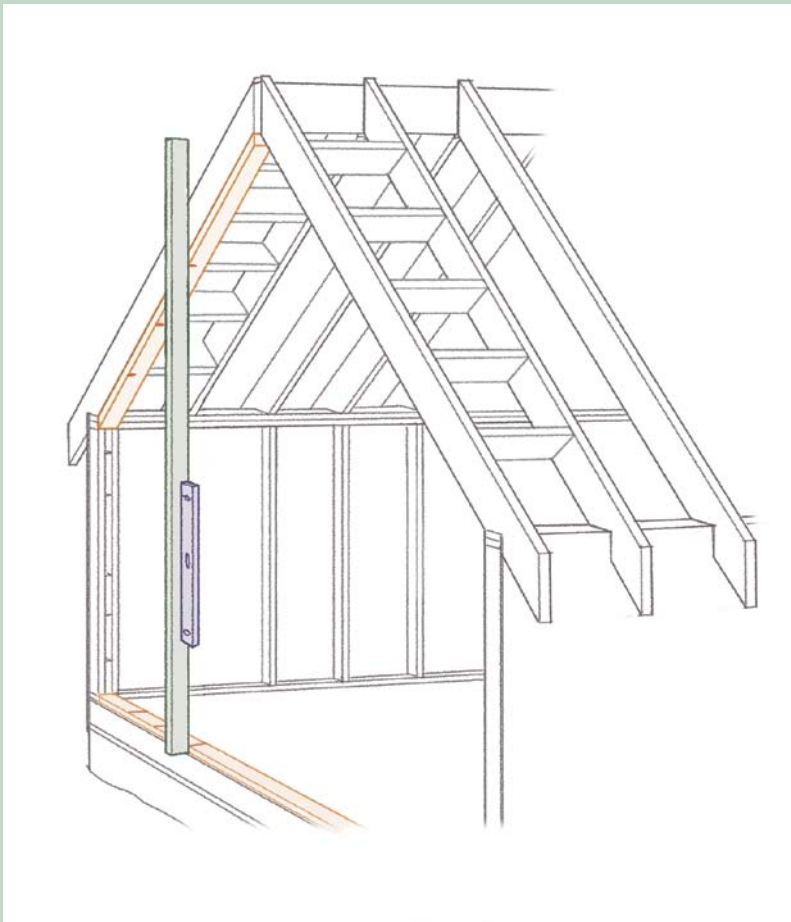

If you like this book, you'll love *Fine Homebuilding*.



Read *Fine Homebuilding Magazine*:

Get eight issues, including our two annual design issues, *Houses* and *Kitchens & Baths*, plus FREE tablet editions. Packed with expert advice and skill-building techniques, every issue provides the latest information on quality building and remodeling.

Subscribe today at:

FineHomebuilding.com/4Sub



Discover our *Fine Homebuilding Online Store*:

It's your destination for premium resources from America's best builders: how-to and design books, DVDs, videos, special interest publications, and more.

Visit today at:

FineHomebuilding.com/4More



Get our FREE *Fine Homebuilding eNewsletter*:

Keep up with the current best practices, the newest tools, and the latest materials, plus free tips and advice from *Fine Homebuilding* editors.

Sign up, it's free:

FineHomebuilding.com/4Newsletter



Become a *FineHomebuilding.com* member

Join to enjoy unlimited access to premium content and exclusive benefits, including: 1,400+ articles; 350 tip, tool, and technique videos; our how-to video project series; over 1,600 field-tested tips; monthly giveaways; tablet editions; contests; special offers, and more.

Discover more information online:

FineHomebuilding.com/4Join

The most comprehensive step-by-step guide to residential carpentry

If the idea of building your own home with your own hands sounds positively exhilarating, *The Complete Visual Guide to Building a House* will show you how. This essential reference takes a unique visual approach to instruction, with over 1,000 drawings of every step in the building process—from laying a foundation through installing the finishing touch on a newel post. Combining the expertise of builder John Carroll and the engaging drawings of illustrator Chuck Lockhart, this guide is just that: *complete*.

John Carroll has been building and repairing houses since the late 1960s. He writes regularly for *Fine Homebuilding* magazine and is the author of two best-selling books, *Working Alone* and *Measuring, Marking & Layout*.

Chuck Lockhart has worked with The Taunton Press for well over 20 years, first as art director for *Fine Homebuilding* magazine, where he helped define the look of the magazine, and most recently as an illustrator of Taunton Press books.

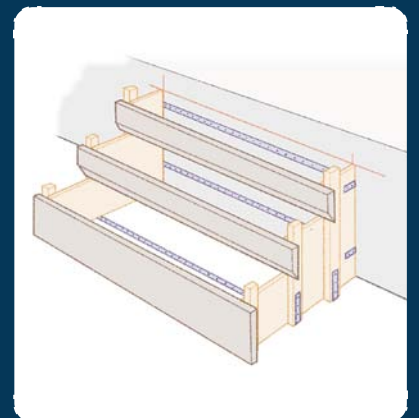
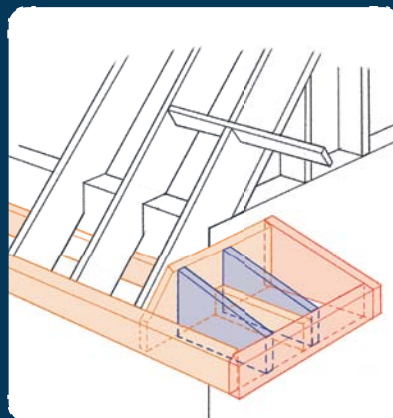
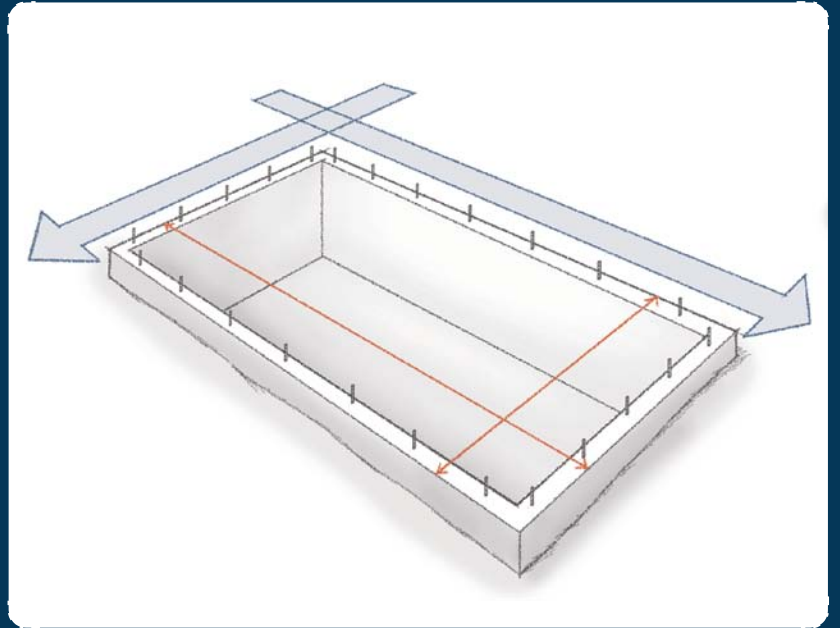

Fine Homebuilding



The Taunton Press
Inspiration for hands-on living®