

Avionics Training Systems, Installation and Troubleshooting

Second Edition

Len Buckwalter

Avionics Communications Inc.
Leesburg, VA, USA

Copyright ©2005, 2007, 2009, 2010 by Len Buckwalter
ISBN 978-1-88-554421-6

All rights reserved. No portion of this book may be reproduced in any form or in any medium without
the written consent of the publisher.

Library of Congress Cataloging-in-Publication Data

Buckwalter, Len.

Avionics training : systems, installation, and troubleshooting / Len Buckwalter.

p. cm.

Includes index.

ISBN 978-1-88-554421-6

1. Avionics--Textbooks. 2. Airplanes--Electronic equipment--Installation--Textbooks. 3.
Airplanes--Electronic equipment--Maintenance and repair--Textbooks. I. Title.

TL693.B752 2005

629.135--dc22

2005045200

Avionics Communications Inc.
P.O. Box 2628
Leesburg, VA 20177 USA

Tel: 703/777-9535

Fax: 703/777-9568

E-mail: len@avionics.com

Visit: **www.avionics.com**

Preface

Avionics is changing rapidly, thanks to the computer revolution, satellites, digital electronics and flat panel displays, to name a few. These changes are also affecting the direction of avionics training.

Technicians a half-century ago were “radio mechanics,” removing broken black boxes from airplanes, taking them to the shop and testing the circuit. They did “all-purpose” maintenance, equally at home on the flight line or work bench. But as avionics grew more complicated, the job was split in two. One person became the “installer” ---troubleshooting on the ramp, or mounting and wiring equipment in airplanes. The other person, trained in repairing circuits inside the box, became the “bench technician,” skilled in troubleshooting down to the smallest component. For decades radio shops separated technical skills this way to service private aircraft in General Aviation.

In the airlines, the division of labor went further. Flightline maintenance was handled by radio mechanics scattered at major airports along their routes, supported by A&P mechanics. After a defective radio was pulled, it was sent back to the airline maintenance depot for repair by bench technicians. Among large airlines, it was usual to have different benches for specialists in each type of instrument or radio; autopilot, automatic direction finder, communications, etc.

By the 1990's, avionics took off in a new direction. Manufacturers began building radios with disappearing parts! Instead of resistors, capacitors and tubes, they populated them with integrated circuits encased in tough epoxy coatings that were difficult to remove. Other components no longer had wires, but were “surface mounted” directly to the board.

Other areas grew smaller. Radios had different sections to tune, amplify or produce some other function but much of that construction is now replaced by invisible software, which instructs the chips to become

just about anything. It's the same idea as a personal computer and its applications software; it's a word processor, spread sheet or video game---at the press of a few buttons.

For the avionics shop, these developments reduce the need for bench technicians to repair down to the component level. Maintaining the new avionics requires expensive automatic test stations beyond the reach of most shops. Today's digital avionics are sent back to the factory or a major depot for repair. Some faults in this equipment, in fact, will not appear unless tests are repeated over many hours, often in a test chamber that runs hot and cold. These tasks must be done automatically, and not by a technician with a pair of test probes.

On the other hand, demand for installation technicians working on the ramp or flightline not only remains strong but will grow. Upgrades for old aircraft continue at a remarkable rate because new-generation equipment makes flying more economical, efficient and safe. Some avionics return their investment in as little as one or two years, then function another ten to twenty.

Airline and corporate aircraft must upgrade to fly in the coming air traffic system---to get more direct routes, altitudes with less headwind, fewer delays and better communication services, all of which repay the cost of avionics and keep passengers happy.

Beyond the flight deck. A whole new category called “cabin avionics” is spreading among airlines. Once called “in-flight entertainment,” it adds Internet connectivity to every seat, e-mail, global telephone, video games and new forms of entertainment. An airliner typically has two or three radios per function in its instrument panel---but hundreds of passenger seats with equipment in the cabin that now fits under the heading “avionics”.

Yet another growth area is the world-wide air traf-

fic management system under construction. No longer will airplanes move point-to-point over land or on crowded tracks to cross the ocean. They will fly directly to their destinations in a concept called "Free Flight," a new mode which depends on satellite navigation and data communications.

The new technician. These developments call for the skills of a technician who understands avionics at the systems level---all the major functions and how they relate to each other. Finding trouble fast is critical in airline operations, where every minute of delay at the gate causes missed connections, lost revenue and angry passengers. In General Aviation, corporate aircraft provide vital transportation for industry. Even the private pilot needs competent servicing for the fleet of light aircraft fitted with the latest "glass" cockpits (electronic instruments). In the pages that follow, some 30 different systems describe a wide range of communications and navigation systems aboard aircraft of all sizes and types.

NFF. A systems understanding reduces one of the costliest errors in avionics maintenance. It's NFF, for "No Fault Found." The technician pulls a suspicious box and sends it back to the shop for repair. There, the diagnosis finds nothing wrong, and the radio is returned to service. Or it may be sent back to the factory or depot. After further testing, the radio is returned labelled "NFF." When the radio is re-installed on the airplane, the problem returns. Not only does it waste hours but often costs the airline over \$8000 in diagnostics, labor and shipping. In the general aviation shop, the no-fault found not only incurs extra expense and wasted time, but an unhappy customer who loses confidence in the shop.

Simplified Diagrams. In describing these systems in this book, there are no schematics showing, resistors, capacitors or other small, internal components.

Instead, simplified block diagrams illustrate the function and flow of signals with arrows. Where the shape of a signal is important, it is illustrated with graphic images.

Most of what is written on avionics is filled with abbreviations and acronyms---TAWS, EGPWS, MFD, TACAN, TCAS---and more. They make an unfair demand on the reader because even the most experienced avionics person must stop at each one and translate it to plain English. For this reason, abbreviations and acronyms are almost always spelled out in diagrams and in the text where they appear.

Gender. Throughout this book, a technician or pilot is referred to as "he." The avionics industry is populated by both genders and this should not be considered insensitivity. It avoids the awkward use of "his/her."

Maintenance Information. This book is not meant to be a "cook book"---with step-by-step instructions for maintenance. It is intended, rather, as a guide to understanding manufacturer's manuals. Also, it does not replace the FAA document on maintenance; Advisory Circular 43.13 1A-2B. This book is intended as a background to understanding manufacturer's manuals that cover specific equipment.

Appreciation. I want to thank the manufacturers who provided me with graphic material and documents. They are credited below their photo, drawing or text. If the reader wants further information, they are easily reached by inserting their name in a search engine along with the word "avionics."

Len Buckwalter
Leesburg, Virginia

Contents

Preface

Section 1 Systems

Chapter 1. The Meaning of “Avionics”	1
First Instrument Panel	1
“Blind Flying”	2
All-Glass Cockpit	4
Chapter 2. A Brief History	6
Sperry Gyroscope	7
Turn and Bank	8
Morse, Bell and Hertz	9
First Aircraft Radio	10
Lighted Airways	11
Jimmy Doolittle; Beginning of Instrument Flight	12
Chapter 3. VHF Com (Very High Frequency Communications) ...	16
Acceptable VHF Com Radios	17
VDR (data radio)	17
Navcom Connections	18
VHF System	19
Com Control Panel	20
Com LRU	20
Splitting VHF Channels	21
Chapter 4. HF Com (High Frequency Communications)	23
HF Control-Display	23
HF System	24
SSB (Single Sideband)	24
Line Replaceable Units	25
HF Datalink	25
Control Panel (Airline)	26
HF Transceiver	26
Antenna Coupler	27
HF Antenna Mounting	27
Chapter 5. Satcom (Satellite Communications)	29
Inmarsat	29
Aero System	31
Space Segment	32
Cell Phones	33
Ground Earth Station (GES)	34
Aircraft Earth Station (AES)	35
Satcom Antennas for Aircraft	36
Steered Antennas	37
High Speed Data	38
Aero Services	39
Chapter 6. ACARS (Aircraft Communication Addressing and	41
Reporting System)	
In the Cockpit	41
ACARS System	42

Messages and Format	43
ACARS Bands and Frequencies	45
Chapter 7. Selcal (Selective Calling)	46
Controller, Decoder	46
How Selcal Code is Generated	47
Ground Network	47
Selcal Airborne System	48
Chapter 8. ELT (Emergency Locator Transmitter)	50
Search and Rescue	51
ELT Components	52
406 MHz	52
406 ELT System	53
Fleet Operation	54
Cospas-Sarsat	55
Chapter 9. VOR (VHF Omnidirectional Range)	57
Coverage	58
VOR Phase	59
VOR Signal Structure	60
Subcarrier	61
VOR Receiver	62
Navigation	63
Horizontal Situation Indicator (HSI)	64
Radio Magnetic Indicator (RMI)	64
Nav Control-Display	65
Chapter 10. ILS (Instrument Landing System)	67
ILS System	68
ILS Components and Categories	68
Approach Lighting	69
Flight Inspection and Monitoring	70
ILS Signals	71
Glideslope	72
Glideslope Receiver	73
Marker Beacon Receiver	74
Marker Beacon Ground Station	74
Chapter 11. MLS (Microwave Landing System)	76
Azimuth Beam	77
Elevation Beam	78
Time Reference	79
Multimode Receiver	79
Chapter 12. ADF (Automatic Direction Finder)	81
Radio Magnetic Indicator	82
Sense	82
ADF System	83
NDB (Non-Directional Radio Beacon)	83
Control-Display (Airline)	84
Line-Replaceable Unit (Airline)	84
Limitations	85
Digital ADF	85
EFIS Display	86
Chapter 13. DME (Distance Measuring Equipment)	88
Obtaining Distance	89
DME "Jitter" for Identification	89
EFIS Display of DME	90
Airborne and Ground Stations	91

Channels X and Y	92
Chapter 14. Transponder	94
Control-Display	94
Transponder Interrogator	95
Panel-Mount	96
ATCRBS and Mode S	96
Transponder System	97
Airline Control-Display	98
Line-Replaceable Unit	98
Mode S Interrogations and Replies	98
Chapter 15. Radar Altimeter	104
Antennas	105
Operation	106
Chapter 16. GPS/Satnav (Satellite Navigation)	108
GPS Constellation	109
Frequencies	110
Satnav Services	111
Panel-Mount Receiver	111
Time Difference Measurement	111
Finding Position	112
The Satellite Signal	113
GPS Segments	114
WAAS: Wide Area Augmentation System	114
Second Frequency for Civil Aviation	112
LAAS: Local Area Augmentation System	116
RAIM: Receiver Autonomous Integrity Monitoring	117
Galileo Constellation	118
Chapter 17. EFIS (Electronic Flight Instrument System)	120
Electromechanical to EFIS	122
Three-Screen EFIS	123
EFIS Architecture	124
Multifunction Display (MFD)	125
EFIS on the B-747	126
Airbus A-320 Flight Deck	127
Chapter 18. Cockpit Voice and Flight Data Recorders	129
CVR Basics	129
Underwater Locating Device (ULD)	131
CVR Interconnect	132
Flight Data Recorder: Solid State	134
Flight Data Recorder: Stored Information	135
Chapter 19. Weather Detection	136
Radar Color-Coding	137
Multifunction Display	137
Types of Detection	138
Radar Transmitter-Receiver	139
Weather Radar Control Panel	140
Lightning Detection	140
Radar Antenna	141
Datalink	141
Radomes	142
Radome Boot	142
Windshear	143
Lightning Detection	145
Windshear Computer	144

Satellite Datalink	145
--------------------------	-----

Chapter 20. TCAS

(Traffic Alert and Collision Avoidance System)	147
Basic Operation	148
Traffic and Resolution Advisories (TA, RA)	150
TCAS System	150
TCAS I and II	150
Coordinating Climb and Descend	150
TCAS Components	150
Whisper-Shout	151
Directional Interrogation	151
Non-TCAS Airplanes	152
TCAS III	152
Voice Warnings	152

Section 2 Installation

Chapter 21. Planning the Installation

Chapter 21. Planning the Installation	154
Replacing "Steam Gauges"	155
Required Instruments and Radios	156
Flight Instrument Layout	157
Basic T	157
Large Aircraft EFIS	158
Flat Panel Integrated	159
Avionics Planning Worksheet	160
Manuals and Diagrams	161
Installation Drawing	162
Connectors and Pin Numbers	162
Pin Assignments	163
Schematic Symbols	164
Viewing Angle	165
Survey Airplane	165
Navcom Connections, Typical	166

Chapter 22. Electrical Systems

Chapter 22. Electrical Systems	168
AC and DC Power	168
DC System	169
Airline Electrical System	171
Switches	172
Lighted Pushbutton	174
Circuit Breakers/Fuses	173

Chapter 23. Mounting Avionics

Chapter 23. Mounting Avionics	178
New or Old Installation?	179
Hostile Areas	179
Selecting Metal	179
Cutting Holes	180
Structures	181
Avionics Bay	182
Airlines (ARINC) MCU Case Sizes	183
ATR Case Sizes	184
Electrostatic Discharge	185
Cooling	186
Cooling for Airline Avionics	187
Locking Radios in Racks	188

Panel-Mounted Radios	188
Remote-Mounted Radios (Corporate)	190
Airline Mounting	191
Locking Systems (Airline)	192
Indexing Pins	193
Integrated Modular Avionics	194
Instrument Mounting	195
Round Instruments: 2- and 3-inch	196
Airline Instrument Mounting	197
Chapter 24. Connectors	199
Typical Connectors	200
RF Connectors	200
How to Identify Connector Contacts	201
Contact Selection	201
Identify Mil-Spec Part Numbers	202
Coaxial Connectors, Typical	203
ARINC Connectors	203
Crimping Contacts	205
Releasing Connector Pins	207
Heat Gun for Shrink Tubing	207
Safety Wiring Connectors	208
Attaching Coaxial Connectors	204
Chapter 25. Wiring the Airplane	210
Swamp	210
High Risk Areas	211
Selecting Wire	213
High-Grade Aircraft Wire	213
Wire Sizes	214
Wire and Cable Types	215
Wire Stripping	216
Nicked or Broken Wires	217
Precut Cables	217
Splicing Wires	217
Location of Splices	218
Ring Terminals	219
Terminal Strip (Block)	219
Marking Wires	220
Harnessing the Wire Bundle	222
Tie Wraps	223
Problems: Chafing and Abrasion	224
Clamping	224
Grounding to Airframe	227
Bending Coaxial Cable	228
Service Loops	229
Chapter 26. Aviation Bands and Frequencies	230
Radio Frequency Bands	231
Higher Bands (Microwave, Millimeter)	232
Low Frequencies	232
Skipping through Ionosphere	233
High Frequencies	233
Very High Frequencies	234
L-Band	234
From Hertz (Hz) to Gigahertz (GHz)	234
Line of Sight Communications	235
Control and Display of Bands and Frequencies	236
Chapter 27. Antenna Installation	239
Antennas for Airline, Corporate and Military Aircraft	240

How to Read an Antenna Spec Sheet	241
Antennas for Light Aircraft	242
Airline Antenna Locations	243
Antenna Types	244
Location	245
Bonding the Antenna to the Airframe	248
Antenna Mounting	249
Antenna Couplers	251
Base Station and Mobile Antennas	252
GPS Antennas	251
Chapter 28. Panel Labels and Abbreviations	254
Silk Screen, Engraving, Tape	254
Panel Abbreviations	255

Section 3

Chapter 29. Test and Troubleshooting	261
ADF	262
Antennas	263
Antenna VSWR	263
Autopilots	264
Com Transceivers	264
DME	265
ELT-Emergency Locator Transmitter	266
Glideslope Receiver	266
Lightning Strikes	266
Software Loading	267
Transponder	267
VOR	268
Wiring and Connectors	270
Fault Detection Device (Wiring)	271
Precipitation (P) Static	273
Avionics Checklist	274
About the Author	275
Index	

Chapter 1

The Meaning of “Avionics”

The word “avionics” first appeared in the 1940’s during World War II. Derived from “aviation electronics,” it referred to fire control systems aboard U.S. Navy aircraft. During that time, the civilian world called it “aircraft radio” or “aviation electronics.” Technicians who repaired them were known as “radio mechanics.”

Avionics remained a military term for 30 more years. Civil aviation could not afford the systems aboard military aircraft. Not only was equipment built to military specifications, but each fighter and bomber had its own avionics suite that fit no other model.

But the world was rapidly changing as new components emerged from research labs; the transistor, integrated circuit, flat-panel display, solid-state memory

and the “computer on a chip.” Small in size and light weight, they consume little power, have few moving parts and, some believe, will operate a hundred years without wearing out. Millions of semiconductors within the size of a postage stamp created the microprocessor, which quickly became known as the “computer on a chip.” It triggered the greatest technical achievement of the 20th Century; digital electronics. For the first time, an aircraft radio could not only receive, amplify, oscillate, filter and perform other simple functions; now it could perform logic, store large amounts of data, send thousands of pieces of information down one pair of wires, warn of problems, correct its own errors---and that’s just the beginning.

First Instrument Panel



The three instruments shown here are ancestors of what will become “avionics” in 50 years. They were installed in the Wright Flyer that made the first successful powered flight in 1903. Although mechanically operated, these gauges will evolve into electronic instruments that comprise avionics on every type of 21st-Century aircraft.

Thus the Wright brothers not only deserve credit for inventing the first practical airplane, but the concept of an instrument panel in view of the pilot to provide valuable flight information.

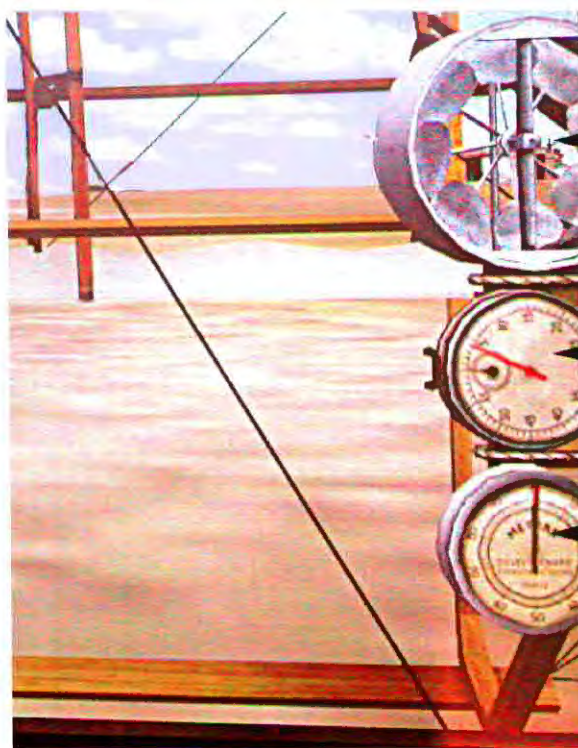

WIND SPEED
(ANEMOMETER)

STOPWATCH

PROP COUNTER
(RPM)

Early Gauges



ALTIMETER

TEMPERATURE

MAGNETIC
COMPASS

TACH (RPM)

OIL
PRESSURE



The Curtiss JN ("Jenny") was the first airplane to fly the US mail in 1918. But a look at the instrument panel shows why pilots were killed while trying to live up to the Post Office motto; "Neither snow nor rain nor gloom of night...stays these couriers from their appointed rounds." No pilot can fly an airplane in very low visibility without "attitude" instruments to replace the sight of the horizon. Even flying at night was considered by an emergency by U.S. Army regulations.

First "Blind Flying" Instruments



After the Wright brothers, Charles Lindbergh made the most famous flight in aviation history. In 1927 he flew solo from New York to Paris in a little over 33 hours. Although celebrated as a hero throughout the world, Lindbergh had more than skill and courage. His panel had a turn-and-bank, a gyroscopic instrument that indicated how rapidly the airplane turned left or right. Without such guidance, he could not have penetrated bad weather and low visibility (still the major cause of fatalities among low-time pilots). Lindbergh's airplane, the Spirit of St. Louis, had another important instrument; an earth inductor compass, shown in the panel. It was powered by an anemometer atop the fuselage (photo at right). This was an improvement over the simple magnetic compass, which is difficult to read in turbulence. Today, the earth-inductor compass is known as a "flux gate" and is standard on all but the smallest aircraft.

TURN-AND-BANK
INDICATOR

EARTH INDUCTOR
COMPASS

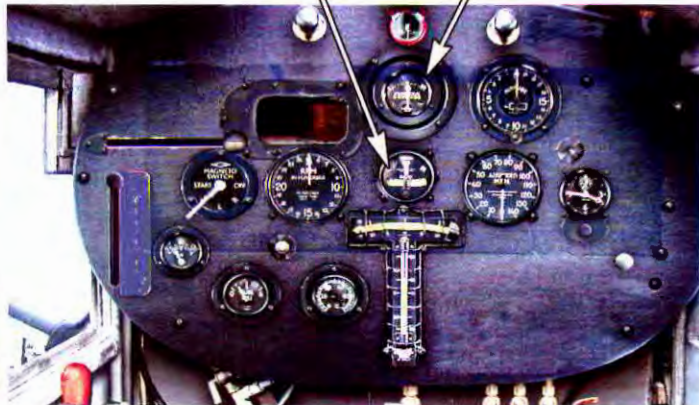

1927 cockpit. Spirit of St. Louis



Wind-driven anemometer powered Lindbergh's earth-inductor compass

Higher Tech, Lower Cost

The new devices were snapped up, not only by the military but the telecommunications and consumer electronics industries. Semiconductors created hundreds of new products, from the personal computer and DVD, to data networks, cell phones and high-definition TV. "Chips" became building blocks of the Internet. Mass production reduced prices so far that a hobbyist could build digital projects with parts from the shelf of a local radio store.

These devices were embraced by aviation, which continuously seeks to reduce size, weight and power consumption. Old vacuum tubes were replaced by tiny integrated circuits that deliver many more functions. By the 1980's the term "aviation electronics," over a half-century old, no longer described a cutting-edge industry. Manufacturers, repair shops, parts distributors, airlines and general aviation sensed the need for a better term to replace "aviation electronics." And what better word than---"avionics?" During that period, "avionics" also appeared for the first time in volumes of FAA regulations on aircraft electronics.

The first generation of the new avionics was so successful, it began to outclass the military. Airlines, business jets and private aircraft were outfitted with flat-panel displays, anti-collision systems, flight management and GPS---long before they reached military cockpits. Recognizing the trend, the U.S. Department of Defense launched a cost-saving program known as "COTS," for Commercial Off the Shelf equipment. Today, many military aircraft are outfitted with civilian avionics of high capability.

Getting out the Mechanicals

An early example of how the new technology was applied is the King KX-170, a combined navigation and communications radio (or "navcom"). Despite rugged construction it contained large mechanical switches with dozens of contacts that inevitably failed.

When semiconductors became available, the manufacturer not only eliminated mechanical switching, but added functions to reduce pilot workload. A new model, the KX-155, could store frequencies and give the equivalent of two radios-in-one. An electronic display eliminated rotating mechanical drums and painted numbers, shrinking the size of the radio and freeing up valuable panel space.

Digital electronics also introduced systems that were impossible to build with old technology. The Stormscope appeared as the first practical thunderstorm detector for small aircraft. Other companies looked at the poor accuracy of fuel gauges, creating a digital fuel flow instrument that measures fuel consumption precisely, and also tells time and fuel to a destination.

Airline View of Avionics

- | | |
|---------------------|--------------------------|
| •Line Maintenance | •Air Conditioning |
| •Test Systems | •In-Flight Entertainment |
| •Communications | •Engine Systems |
| •Indicating Systems | •Fire Detection |
| •Navigation | •Landing Gear |
| •Autoflight | |
| •Flight Controls | |
| •Electrical Power | |
| •Lighting | |

These major topics are discussed each year at the Avionics Maintenance Conference, run by ARINC, the airline avionics organization. The left column shows traditional avionics. But as electronics creep into other systems, shown in the right column, they often become the responsibility of avionics maintenance.

In the airlines, the digital revolution just about eliminated the problem of "mid-air." After two airliners collided over the Grand Canyon in 1956 the FAA investigated several anti-collision systems. Every design failed because of high cost, weight, size or an inability to detect small aircraft. One system required an on-board atomic clock, which cost more than most airplanes.

But as the price of computing power dropped, "TCAS" (Traffic Alert and Collision Avoidance System) became practical. It warns when two aircraft head toward each other with a closing speed over 1,000 miles per hour---and detects most small aircraft not equipped with TCAS.

Gauges: From Round to Rectangular

By the 1970's cockpits of aircraft began to lose their "steam gauge" appearance, where instrument panels resemble an 1830 railway locomotive. Instead of round dials and pointers, the new look became the "glass cockpit," where separate gauges are replaced by images on a CRT or flat panel LCD. The system is called "EFIS," for Electronic Flight Instrument System and it rapidly spread through every size aircraft.

Today, a blank screen may become any instrument---altimeter, airspeed, tachometer---or all simultaneously. It's done by modifying software, or simply changing the plug on the back during installation. This

Toward the All-Glass Cockpit

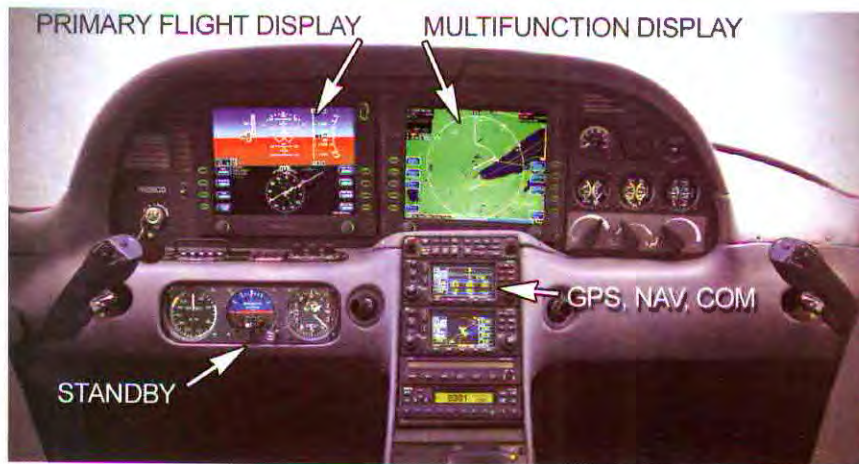

The trend toward the “all-glass” cockpit is seen in this instrument panel for a Cirrus aircraft. Round gauges are replaced by large LCD screens which produce images of any instrument. What remains of the old-style panel is at the lower left, where standby instruments act as backup. In the center stack, GPS navigation and communications are integrated into one radio, with a backup below it. There are no large control yokes. They are replaced by sidestick controllers which give

the pilot an uncluttered view of the instrument panel. The large Primary Flight Display shows all flight instruments, weather, moving map and traffic. The Multifunction Display can also show these functions. Having two such displays enables the pilot to put flight instruments on one screen and navigation and terrain on the other. This advanced cockpit is neither a military nor airline system, but in a kit-built airplane. The large panel displays are Avidyne’s Flight Max.

tells the screen what it will be. This also reduces the number of spares needed on the shelf, a great cost benefit to airlines flying far-flung routes.

More than CNS

As the term “avionics” established itself in the civil world, it divided into three categories often called “CNS”---Communications, Navigation and Surveillance (the last referring to radar surveillance). CNS includes most avionics systems installed on the airplane. An autopilot, for example, falls under “Navigation,” a transponder is a component of “Surveillance.”

The list of avionics, however, grows longer. A look at the agenda of the Avionics Maintenance Conference (an airline organization) reveals more than CNS. One-third of the new items were never considered avionics or even aircraft electronics (see table “Airline View of Avionics). What happened is that engineers began using semiconductors to replace sections of mechanical and hydraulic systems. The nose wheel steering of a LearJet, for example, is by microprocessor. Engine control is no longer through levers and steel cable. It is done by FADEC, for Full Authority Digital Engine Control, which provides better fuel economy, precise engine settings and protection against

excess temperature and pressure. Each year the aviation industry moves closer to what it calls the “all-electric airplane,” a concept that will slash heavy oil-filled hydraulic lines, steel control cables and hundreds of miles of copper wire. In their place will be thin wires carrying multiple messages (the “databus”) to electric actuators. These airplanes will fly farther on less fuel and in greater safety. Airliners are already equipped with the first of the “fly-by-wire” systems.

The growth of avionics is also reflected in the price tags of aircraft. In the transport aircraft of 1945-1950, about five percent of the cost was electrical, radio and lighting systems. Some 20 years later, that portion quadrupled to about 20 percent. More recently, airlines added the most costly and extensive electronics aboard aircraft. It is IFE, or In-Flight Entertainment, also called “cabin electronics.” If an airplane has 300 seats, that means 300 IFE installations, each wired for audio, video, satellite phone, Internet and other services. In the military sector, the cost of a fighter aircraft rose to more than 40 percent for avionics.

These percentages can only increase. Airplanes divide into three main sections; airframe, propulsion and avionics. Airframes have grown larger but they still fly with the three-axis control system patented by

the Wright brothers. In propulsion, the jet engine is a marvel of reliability and power, but it still works on a basic principle---action and reaction---defined by Isaac Newton 300 years ago.

Avionics, on the other hand, re-invents itself nearly every ten years, providing the industry with fresh solutions to rising fuel prices, fewer airports and crowded skies. To find answers for the 21st Century, two hundred countries of the world under the banner of ICAO

(International Civil Aviation Organization) deliberated for 20 years. They agreed that technology is here and aviation is ready for its biggest change in moving more airplanes safely within limited airspace, and provide passenger services to make the flight enjoyable and productive. Nearly all the systems--- described throughout this book---are created from building blocks provided by avionics.

Review Questions

Chapter 1 The Meaning of Avionics

1.1 In the first solo across the Atlantic in 1927, how did Charles Lindbergh keep control of the airplane while flying in clouds and darkness?

1.2 Name three instruments used by the Wright Brothers in their first flight that marked the beginning of what would become “avionics”.

1.3 What generated power for Lindbergh’s earth-inductor compass?

1.4 Why do airlines consider the following systems part of “avionics”: air conditioning, fire detection, landing gear?

1.5 What technology was widely adopted in avionics to reduce size and weight, as well as provide greatly increased function.

1.6 What system, made possible by digital electronics, greatly reduces the problem of mid-air collisions?

1.7 What replaces early “steam gauges” in aircraft instrument panels?

1.8 How can the function of an electronic instrument be easily changed?

1.9 What does “CNI,” which describes basic functions of avionics, stand for?

1.10 What does the term “FADEC” mean?

1.11 Name the world body that deliberates future aviation technology?

1.12 “Avionics” is a contraction of _____ and _____.

Chapter 2

A Brief History

The invention of the airplane is tied to the beginning of radio. Both arrived at about the same time; the Wright brothers made the first powered flight in 1903, two years after Marconi sent the first radio messages 2100 miles over the Atlantic from England to Canada. Until then, people flew in hot air balloons or glided downhill in oversize kites. Radio was a laboratory curiosity and one of its early experimenters (Hertz) didn't think much would come of it.

Aviation and radio quickly grew together with the coming of World War I (1914), when airplanes proved to be deadly fighting machines. When the war ended, barnstorming pilots spread over the countryside, amazing people with stunts and joy rides in open bi-planes. But when the young industry attempted to get serious by transporting people and mail--- the results were di-

sastrous. Many air mail pilots lost their lives in crashes where nothing went wrong with the airplane. Somehow, when fog or cloud obscured a pilot's view outside, even the most skilled pilot couldn't keep the airplane straight and level. For this reason, military pilots were warned that flying at night is an emergency. This inability to remain upright in less than visual conditions also held back early airliners. A passenger flying from New York to Los Angeles hardly gained time over riding the railroad. When darkness fell, he got off the airplane, boarded an overnight train---then reboarded the airplane in the morning.

First Radio Waves Over the Atlantic



G. Marconi, after experimenting at his home in Italy, was first to communicate long distances by radio. In a 1901 demonstration, he sent signals over two thousand miles. The first message was three dots---the letter "S" in Morse code. Early aircraft radio adopted the Marconi system, which consisted of a spark transmitter and magnetic detector for receiving. Although not known in 1901, the ra-

dio signals had travelled great distances by "skipping" from an electrical layer known as the ionosphere. Skipping is still used today by long-range aircraft with high frequency (HF) communications.



The first practical use of aviation and electronics began at nearly the same time. The Wright Brothers' first powered flight was 1903. The first radio message was sent from England to Canada in 1901.

What went wrong? The aviation community discovered that, no matter how experienced the pilot, he cannot control an airplane when unable to see outside. Whether it's fog, cloud, blowing snow, dust or other obscuration, *any* pilot is about five minutes from losing control.

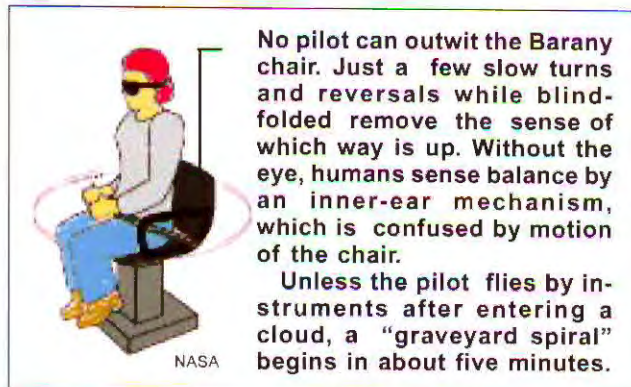

This is clearly demonstrated by FAA in its notorious "Barany chair," which is demonstrated at air shows and safety meetings. A pilot sits in the chair blindfolded. The instructor turns the chair (which is on a rotating base) at moderate speed. After several revolutions, the chair is stopped and the pilot asked, "Point to the direction that you're turning." As the pilot points, the audience breaks into laughter; he or she is pointing in the *opposite* direction. It is comical to watch, but is also the greatest killer of pilots. The accident report reads; "Continued VFR (visual) flight into IMC (Instrument Meteorological Conditions)."

The reason is that the eye is the primary organ for indicating "which way is up." When vision outside is blocked, however, the inner ear, which controls sense of balance, takes over. The problem is, the balance mechanism is easily fooled. When the Barany chair turns, the inner ear responds first to acceleration. When the chair is stopped the pilot senses deceleration. But the rotating motion of the chair confuses the inner ear and the pilot gives the wrong answer when asked which way he's turning.

Now transfer this scenario to an airplane entering a cloud. The untrained pilot looks out the windows and sees solid gray. Let's assume a gust of turbulence moves one wing down---then, a second or two later the wing slowly returns to level by itself. This causes the same phenomenon as in the Barany chair, causing the pilot to correct in the wrong direction. The airplane enters a tightening spiral from which there is rarely a recovery.

To worsen matters, there is another false clue. In straight and level flight, a pilot feels gravity pushing him into the seat. But in a turn, centrifugal force starts acting on his body---and it feels exactly like gravity. The pilot believes he is still sitting vertically and has

no feeling the airplane is turning and descending. That's what confronted the budding aviation industry. Unless a pilot had artificial guidance inside the cockpit, airplanes would remain in the realm of barnstorming and air racing.

The breakthrough happened when Elmer Sperry invented the "turn and bank" indicator. Using a gyroscope as a stable platform, a needle on the instrument showed when the airplane entered a turn. If the pilot

Sperry Gyroscope (1914)

The greatest single device for aviation safety was the gyroscopic instrument, a spinning wheel that remains stable, even as the aircraft maneuvers. This provides the pilot with a reference within the cockpit when he cannot see outside. A gyro is shown here with Elmer Sperry, the inventive genius who applied it to the turn-and-bank indicator, the first life-saving device for instrument flight. Sperry went on to develop the artificial horizon, autopilot and other systems based on gyroscopes.



"Look...no hands!"



Sperry also used the gyroscope to design the first autopilot. A remarkable demonstration in 1914 is shown above. Sperry's son, Lawrence, is in the pilot's seat, holding his arms away from the flight controls. Standing on the wing to the left is a mechanic, whose weight should cause the wing to drop. The airplane, however, is stabilized by Sperry's gyro control system and remains level. The inventor wins France's Airplane Safety Competition (50,000 francs) and the distinguished 1914 Collier Trophy in the U.S.

It Started With Turn-and-Bank

This simple turn-and-bank indicator was a breakthrough that turned the flying machine into a practical airplane. Developed by Elmer Sperry and his gyroscope, the instrument began the quest for all-weather operations. A pilot could now fly with confidence inside clouds, approach airports during low visibility and fly safely on dark, moonless nights.

The instrument indicates if the airplane is turning. The turn needle remains centered so long as the wings are level. But if a gust lowers a wing, the airplane starts a turn, causing the needle to move to one side of center. Shown here is a turn to the right, as the needle moves under the right tick mark, usually called a "dog house." The pilot now knows he should apply left aileron to bring the wings back to level, which stops the turn.

The instrument does *not* show bank angle, or position, of the wings. It indicates only "rate of turn"---or how fast the airplane is turning. This is sufficient information to keep the wings level. If the pilot wants to turn, he lowers a wing with the aileron and puts the needle on the "dog house." The airplane now turns at the rate of 3 degrees per second.

The ball at the bottom is not a gyro instrument, but moves freely. It helps the pilot coordinate the turn with the rudder (or the airplane would slip or skid in the air). Keeping the ball centered with the rudder during a turn assures good control of the airplane when there is no view outside.

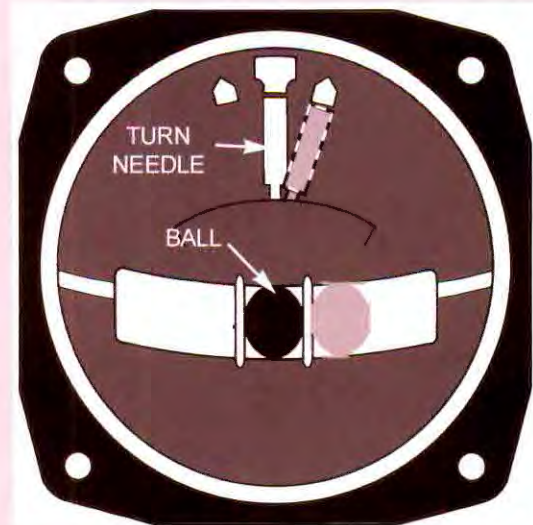

The effectiveness of the turn and bank instrument was shown during Charles Lindbergh's solo flight across the Atlantic to Paris in 1927. During the ocean crossing he spent several hours on the instrument to fly through bad weather.

The turn and bank is sometimes called the "turn-and-slip indicator," and is still required in many aircraft as a backup. A later version is called a "turn coordinator." Today, an improved gyro instrument, the artificial horizon, is the primary reference for instrument flying.

kept the needle centered, the airplane remained in level flight. Sperry's device removed a major obstacle to dependable flight operations.

Instruments were greatly improved by 1929 through the work of Jimmy Doolittle (who later became an Air Corps General in World War II). He came up with the idea of an artificial horizon that displayed the wings of an airplane against a horizon line. As the airplane maneuvers, the pilot sees miniature wings bank left or right, and rise and fall with the angle of the nose. By showing wing and nose position---roll and pitch--- on one instrument, the display is easy to fly because it recreates what the pilot sees through the windshield on a clear day. The artificial horizon was designed around Sperry's gyros.

Now that an airplane could be controlled in almost any visibility condition, aviation was ready for the next advance; the guidance required to fly to cross-country to a destination airport and make a safe landing. The first attempt placed a lighted beacon (like a

lighthouse) every 10 miles along the route. It was an immediate success; airplanes could fly at night, speeding mail and passengers in less time. The day of navigating by compass, chart and timepiece seemed to be over.

But it soon became painfully obvious that light cannot penetrate fog, clouds and heavy snow. The answer was to abandon guidance by light and create airways formed by radio waves, which easily move through any form of precipitation.

The 1930's saw great advances in radionavigation and the growth of commercial aviation. Let's look at milestones that merged aviation and electronics into one of the fastest, safest forms of transportation.

Morse and the Code



Code keys were found aboard long-range aircraft of the 1930's. Radio operators were called "brass pounders."

Samuel FB Morse was first to transmit information by electrical signals. In an 1836 demonstration between Baltimore and Washington, DC, letters are encoded into dot and dashes. The first message: "What hath God wrought?"

Early aircraft used Morse code because voice was not possible until the invention of the vacuum tube.

Morse code survives today as the identifier for thousands of radionavigation stations. To avoid navigation error, pilots must listen to a station's identifier before using the signal (although many stations are also identified by voice).

First Voice Transmission



Alexander Graham Bell, inventor of the telephone, was first to transmit voice through wires (1876). The technique is later applied to wireless voice transmission and adopted by aviation for air-ground communications.

Bell announced his next project would be a "flying machine." He worked closely with Glenn Curtiss, who improved airplane design after the Wright brothers accomplished the first successful flights.

Hertz Demonstrates Radio Waves



Heinrich Hertz

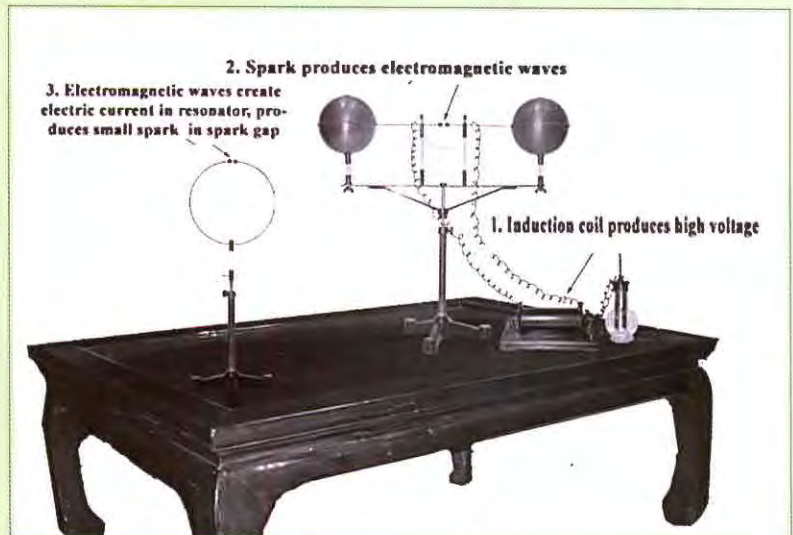

In a Berlin laboratory in 1887, Prof. Heinrich Hertz sends radio waves across a room. A transmitter (on the right) discharges sparks across a gap, creating radio waves. A receiver (left) responds by producing sparks (the received signal) across metal balls. The Professor is honored 160 years later when his name becomes the term to describe radio frequency as "hertz." Meaning the number of cycles per second, it's now written as kilohertz (kHz), megahertz (MHz), gigahertz (GHz), etc.

After the experiment, Prof. Hertz's students asked, "So what is next?" Hertz replied with the understatement of the century; "Nothing, I guess."

First Aircraft Radio

Carried aboard a Curtiss bi-plane in 1910, this rig made the first radio transmission from air to ground while flying over Brooklyn, NY. It weighed 40 lbs and mounted on a 2-ft-long board strapped to the airplane's landing skid. The pilot, James McCurdy, a Canadian aviation pioneer, transmitted with a Morse code key mounted on the control wheel.

The transmitter was a spark type. An induction coil created high voltage from a 6-volt battery (seen at far right). When the operator closes the code key, voltage jumps across a spark gap (much like a spark plug in an automobile). This sends current into the large coil at left. The coil is part of a tuning circuit which causes energy in the spark to circulate back and forth at a rapid rate. This is coupled to an antenna wire trailing outside the aircraft, which converts the oscillations into radio waves. In later experiments the aircraft carried a receiver to hear transmissions from the ground.

Spark transmitters were inefficient and emitted signals on many frequencies at the same time. Not until the invention of the vacuum tube, which could generate clean, powerful signals, did 2-way radio become practical in aircraft. The vacuum tube also made possible transmission of the human voice.

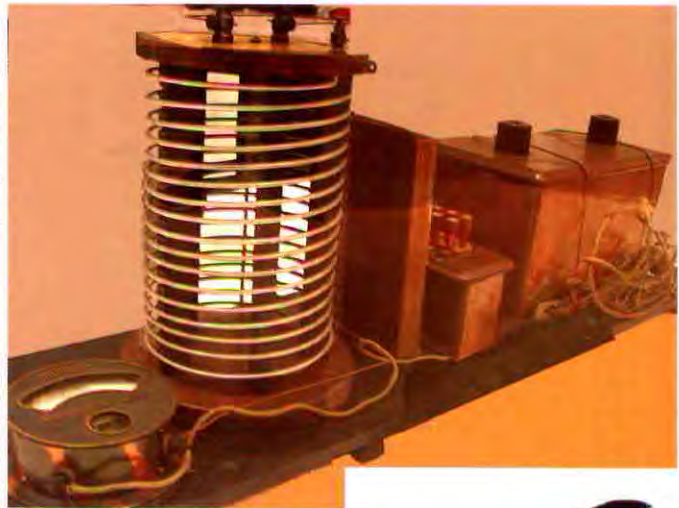

1910 Curtiss Biplane

Air-Ground Messages in England



Marconi Museum



Thorne-Baker in England holds a 1910 aircraft radio which used a Marconi electromagnetic detector for receiving. He communicated with a Farman biplane flying one-quarter mile away.

The radio aboard the airplane was a 14-lb transmitter fastened to the passenger seat. Pilot Robert Loraine transmitted with a Morse code key tied to his left hand. The antenna consisted of wires fastened along the length and width of the airplane.

Flying Machine Rescued by Radio

Lifting off from New Jersey in 1911, the airship *America* headed toward Europe. Encountering bad weather and engine problems 100 miles out, the crew abandoned the airship and took to a lifeboat. The wireless operator was able to communicate with the nearby Royal Mail Steamship *Trent*, which rescued the crew. The Marconi radio had a guaranteed range of 30 miles.

Note the cable dropping from the airship. It trailed in the seawater to provide a good electrical ground for the antenna.



Marconi Museum



Lighted Airways

Before 1926, air mail pilots could fly only during the day. That changed when lighted beacons were installed every 10 miles. A rotating light appeared to the pilot as a flash every ten seconds. Just below the beacon were course lights that pointed up and down the airway. Course lights also flashed a number code, the same number that appears on the roof of the building. "5" indicates it is the fifth beacon in a 100-mile airway. Although lighted beacons shortened the time for mail delivery, their effectiveness was poor in bad weather. Navigation by radio waves would provide the solution.

1927. Aviation receives own radio frequencies.

The International Radio Convention meets in Washington, DC to assign aircraft and airway control stations frequencies for their exclusive use.

1928. US Dept. of Commerce expands stations.

This year begins the rapid expansion of ground radio stations for transmitting weather and safety information to pilots. Old "spark gap" transmitters capable only of code are replaced by equipment that carries voice. Until this time, aircraft could only receive, but an increasing number install transmitters for two-way communication with the ground. By 1933 there were 68 ground stations. The next year, over 300 aircraft flying airways had two-way radio; over 400 could still only receive.

1928. First practical radionavigation.

U.S. Department of Commerce adopts the "four-course radio range," where pilots listen in headsets for audio tones that get them "on the beam." After beginning between Omaha, Nebraska and New York, the stations spread through the country. The last four-course range was taken out service in Alaska in the 1970's.

1928 was also the beginning of teletype machines to carry

weather information throughout the US.

1929: First aircraft operational frequencies.

Until now, radio was only to send weather and safety information to pilots. This year, the Federal Radio Commission assigned frequencies to airline companies to allow them to speak directly with their aircraft in flight

This led to the creation of "ARINC" (Aeronautical Radio Inc), an organization of airlines which operates communications services today.

Another development during 1929: pilots flying airways were required to report their position, thus marking the beginning of Air Traffic Control.

1930: Airport traffic controlled by radio.

First installed at Cleveland, the system spreads to 20 more cities in the next five years (replacing the flagman on the roof).

1931: Weather maps begin.

Experiments transmit weather maps over the same teletype machines used in the Federal Airway System (which had been capable of operating only on paper tapes). By the next year, maps of the U.S. were transmitted six times per day to 78 cities. Briefers on the ground could now give pilots weather information.

Jimmy Doolittle and Beginning of "Blind" Flight

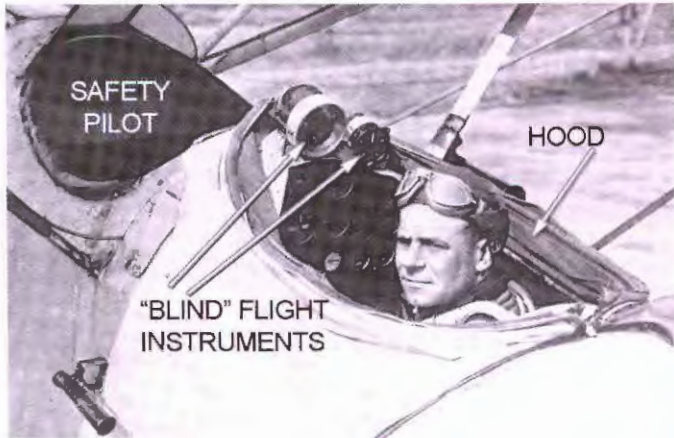

Jimmy Doolittle, an army lieutenant, was the first to take off, fly a course and land without seeing outside the cockpit. He controlled the aircraft solely by reference to instruments. Attitude information (pitch and roll) were indicated on an artificial horizon. A directional gyro, more stable than a magnetic compass, indicated direction, while a "sensitive" altimeter, which could be corrected for barometric pressure, replaced the conventional instrument.

Doolittle followed a radio course aligned with the runway created by a radio range station on the ground. Marker beacons indicated the airplane's distance from the runway.

The flight was the single most important demonstration of what would become "avionics." Because guiding aircraft to landing had been done only by light signals, which don't penetrate clouds, Doolittle's flight made commercial aviation a reality.

1931: Glideslope Appears

By tilting a radio beam vertically, experimenters at College Park, MD created an electronic path that matched the glide angle of an airplane. Airplanes now had guidance for descending to a runway in low visibility. It later became the glideslope part of the ILS (Instrument Landing System).

1932: Instrument Rating Required

Air Commerce Department rules that air transport pilots must show an ability to use airway navigation aids and fly certain maneuvers guided entirely by instruments.

1933: Cross Country Instrument Flight

Bureau of Standards demonstrates a radio system for blind flight. Arriving at Newark, NJ, from College Park, MD, the airplane flew the first cross-country all-instrument flight.

1935: Radar

The Defense Research Council of Great Britain receives a report on a new system known as "radar" (for radio detection and ranging). It goes on to become a chain of stations along the

British Isles for detecting hostile aircraft during World War II. To avoid shooting down friendly aircraft, a device known as IFF, Identification, Friend or Foe, is installed on British airplanes. Today IFF is known as the "transponder." Later in the war, the Massachusetts Institute of Technology scales down the size of radar for installation aboard aircraft, the first major instrument of electronic warfare.

1935 Air Traffic is Controlled

Airlines operate the first airway traffic control center at Newark, NJ, to provide safe separation for aircraft flying in instrument conditions. Chicago and Cleveland soon follow. It is the beginning of the en route Air Traffic Control system to separate traffic after it leaves the airport area.

1940: Radio for Oceanic Flight

Six powerful high-frequency radio stations are installed on Long Island, NY, to provide the first two-way radio communications for aircraft flying the Atlantic. The frequencies are in the HF band which, unlike lower aviation bands, "skip" great distances.

These stations also play an important role in ferrying military aircraft to England at the outbreak of World War II.

1944: ICAO is Born

Fifty-two countries meet in Chicago to launch ICAO, the International Civil Aviation Organization. The first global aviation authority, ICAO will publish standards to assure technical uniformity throughout the world. By 2004, ICAO had 188 member countries, which it calls "States."

1945: GCA Honored

The distinguished Collier Trophy is awarded to Dr. Luis W. Alvarez for his concept of Ground Controlled Approach. GCA uses a ground-based radar that emits two beams; one to indicate aircraft distance from the runway, the other to measure its height above ground. The radar operator watches the display and "talks" the pilot down to landing. Although successfully used by the military, GCA was never adopted for civil use. Airline pilots and government authorities preferred the Instrument Landing System (ILS), which became the standard for well into the 21st Century.

1946: Radar-equipped Control Tower

At Indianapolis, a demonstration of the first control tower equipped with radar for civil flying. Adapted from naval equipment, it could reduce ground clutter by ignoring targets not in motion.

Today, this type of radar is known as a Tracon, for Terminal Radar Control, and manages traffic in and out of airports at a range of 30-40 miles.

1947: VOR Commissioned

After experimenting on the New York-Chicago airway, the



During the 1920's, traffic in and out of airports was controlled by a flag man standing atop a hangar.

Civil Aviation Authority opens the first VOR (Very High Frequency Omnidirectional radio range) station. VOR grows rapidly to about 1,000 stations throughout the U.S. and replaces the obsolete four-course radio range.

1947: Navy Pursues TACAN

An effort to make VOR a common system for both military and civil navigation fails. The U.S. Navy selects TACAN (Tactical Air Navigation), a development which the Navy needed during the Korean War in 1950.

Since most military flying is done in civil airspace, military aircraft must also be equipped with VOR receivers. On the other hand, civil aircraft use a part of TACAN to operate their DME (Distance Measuring Equipment).

1948: Bell Labs Demonstrates the Transistor

In searching for a device to replace electromechanical switches in telephone systems, Bell scientists invent the transistor. It was tiny, had no moving parts, didn't wear out and generated little heat.

The transistor will become important in avionics for the same reasons.

1953: Transmissometer Installed

The first electronic device for measuring visibility on the ground is completed at Washington National Airport. Located



Before surveillance radar, air traffic controllers plotted aircraft from pilot position reports sent by radio. Today, traffic is viewed on radar screens. Note the four-course radio range station on the chart. It provided radionavigation during the 1930's, but was later replaced by VOR and ILS.

alongside the runway, a transmitter sends a light beam to a receiver several hundred feet away. The receiver measures the loss of light due to fog or other obscuration and converts it to RVR, or Runway Visual Range. This value, in feet, is more accurate than a human looking at a distant point and estimating visibility.

1956: Airliners Collide

A TWA Constellation and United DC-7 collide over the Grand Canyon (Arizona) killing 128 people. Both airplanes were flying VFR (visually) on a sunny day in wide open airspace.

The response by authorities is to require all aircraft flying over 18,000 feet to fly IFR (instrument flight rules), keeping them under positive control, in radar surveillance and safely separated.

The accident starts development of an on-board anti-collision system. The search continues for 40 years---until the introduction of TCAS (Traffic Alert and Collision Warning System).

1957: Narrow Band Receivers

The Civil Aeronautics Administration (CAA) begins installation of new radios designed to double the number of aviation channels. Until that time, radio channels were 200 kHz apart. The new radios "split" channels for a spacing of 100 kHz.

1956: Flight Recorders

The CAA rules that air carrier and commercial aircraft over 12,500 lb must have a flight data recorder by 1958. The FDRs record airspeed, time, altitude, vertical acceleration and heading.

1957: Boeing 707 first flight

After building 857 airplanes, 707 production ends in 1991.

1958: FAA and NASA are Born

During April and May, military aircraft collided with civil airliners in two separate accidents. The collisions raised a storm of protest to eliminate the Civil Aeronautics Agency, which controlled only the civil sector. Legislators call for a unified agency to control both military and civil aircraft when flying in civil airspace.

Later that year, Congress passes the bill that creates the FAA (Federal Aviation Administration). A major responsibility is to control airspace in the US and develop a common system of air traffic control for civil and military aircraft.

In October of the same year, Congress creates NASA (National Aeronautics and Space Administration). Although NASA is identified with space exploration, it also justifies the "aeronautics" part of its name. NASA will contribute to airline avionics in the form of databuses, displays, synthetic vision and human factors. It will solve problems in small aircraft that limit their usefulness in bad weather. There are NASA programs on safer cockpits, airframe icing and low-cost anti-collision devices.

1959: DME Approved

The International Civil Aviation Organization chooses DME (distance measuring equipment) as the world standard to complement VOR navigation.

1959: Transponders Begin (ATCRBS)

Known as "secondary radar," the transponder not only provides more powerful returns than conventional radar, but encodes aircraft identification as well. It is based on World War II "IFF" (Identification, Friend or Foe).

The system is "ATCRBS," for Air Traffic Control Radar Beacon System, and triggers replies from an aircraft transponder. The first ground interrogator is installed in New York and expands to 19 more air route traffic control centers. A pilot can dial up to 64 codes (for ID), which is expanded to 4096 codes in later equipment.

1960: Airborne Weather Radar

FAA requires US airliners to carry airborne weather radar. It is phased in over several years and, in 1966, expanded to cover large cargo aircraft.

1960: More Com Channels

The first increase in VHF communications channels in the aircraft band since 1946. It adds 5 megahertz to the band, with 100 more channels for air traffic control. The new channels, in MHz: 126.825 to 128.825, 132.025 to 135.0

1964: Cockpit Voice Recorders

FAA requires CVRs in large turbine and 4-engine aircraft. In the event of an accident, the recorder provides cockpit conversation during the 30 minutes preceding the crash.

1964: Inertial Navigation Systems (INS)

Pan Am installs INS on most of its jet aircraft to provide accurate navigation over oceans and remote areas where ground stations are not available.

1964: Category II Landings

FAA announces requirement for Cat II (ILS) instrument landings, another step toward all-weather operations. Decision height is lowered to 100 feet and runway visibility range (RVR) of 1200 feet. United Airlines is first to qualify, with its DC-8s

(in 1965).

1964: Helicopter Certified for IFR

Sikorsky S-61 becomes first civil helicopter to be certified for IFR (Instrument Flight Rules).

1964: Single Sideband Radio (SSB)

FAA begins operating first single sideband (SSB) ground station in Alaska for air traffic control over the North Pole. SSB, which operates in the high frequency (HF) band, will eventually replace older, less-efficient HF radio for oceanic and remote communications.

1964: First Automatic Touchdown

A British European Trident at London makes the first automatic touchdown of a scheduled commercial airliner carrying passengers.

1965: DME

FAA requires large foreign transports flying in U.S. to carry Distance Measuring Equipment (DME)

1966: Satellite Communications

FAA reports "voice messages of excellent clarity" during first test of a satellite for long-range communications. The vehicle is NASA's Applications Technology I. "Satcom" will eventually replace High Frequency equipment.

1967: Satcom Datalink

FAA and NASA demonstrate a datalink system using a satellite for transmitting navigation data from aircraft to ground stations. A Pan AM cargo jet sends data to the ATS-1 satellite, which relays it to a ground station in California. It is also the first test of an aircraft antenna designed to transmit satellite messages.

1968: Altitude Alerting

FAA requires an altitude alerting system on turbojet aircraft because of their rapid climb and descent rates. Pilot presets an altitude and receives aural and visual warning in time to level off. Also alerted is straying from an assigned altitude.

1970: Microwave Landing System (MLS)

Secretary of Transportation forms group to study development of MLS, the eventual replacement for ILS

1970: Satcom for Air Traffic Control

FAA establishes communications via satellite between San Francisco and Hawaii. The first full-time satcom for air traffic control uses Intelsat. Because of superior communications, FAA

closes down High Frequency station in California.

1970: Advanced Flight Data Recorder (FDR)

FAA requires advanced FDR's for large transport aircraft. The new type records over three times more information.

1972: Category IIIa Landing

TWA receives first authorization to operate Cat IIIa (ILS) weather minimums. It allows Lockheed L-1011 to operate down to visibility of 1000 feet (Runway Visual Range), then as low as 700 ft RVR.

1973: Mode C Transponders

FAA requires aircraft flying in Terminal Control Areas (which surround major airports) to carry transponders capable of Mode C (altitude reporting).

1973: Public Address System

FAA issues a rule requiring aircraft carrying more than 19 passengers to have public address and interphone systems to keep crew and passengers informed during an emergency.

1974: Radio Range Shut Down

The last four-course radio range, located in Alaska, is decommissioned by FAA. Replaced by VOR and ILS, it was the first radionavigation system for "blind" (instrument) flight in bad weather. The four-course radio range was important for the growth of aviation during the 1930's.

1974: Ground Prox Installation

A rule requiring Ground Proximity Warning Systems on airliners is published by FAA. GPWS warns when the aircraft is below 2500 feet and in danger of closing too rapidly with the ground.

1980: Avionics and Two-Person Crews

Boeing plans on two-person crew for its new B-757-767 airliners. Digital systems in these aircraft reduce the need for third person (flight engineer). It's made possible by new EFIS (Electronic Flight Instrument System), which centralizes instruments and displays, as well as automatic monitoring of engine parameters.

1981: FAA Selects TCAS

FAA adopts the Traffic Alert and Collision Avoidance System (TCAS). Compatible with existing and future transponders, there are two versions: TCAS I, which delivers only a traffic alert, and is practical for small aircraft; and TCAS II, which adds vertical escape maneuvers and is required for airliners.

Radar surveillance room of an Air Traffic Control facility. Pilots call in position reports by radio; the airplane appears on the "PPI," or Plan Position Indicator, seen at lower left. "Flight Strips" are print-outs which inform the controller of flights arriving in his sector. These paper strips are replaced in future ATC with electronic displays.



FAA

TCAS III, which adds horizontal maneuvers, proved difficult to develop and was dropped.

Future anti-collision systems will be based on satellite surveillance.

1981: Search and Rescue Satellite

U.S. launches weather satellite carrying Search and Rescue Satellite-Aided Tracking (SARSAT). It is capable of receiving signals from an aircraft ELT (Emergency Locator Transmitter). A similar satellite called COSPAS is launched in 1982 by the USSR (now Russia).

1983: GPS Nav Across the Atlantic

A Rockwell International Sabliner is first to cross the Atlantic guided only by GPS.

1984: Loran Approved

FAA approves Loran as an area navigation system for IFR (Instrument Flight Rules) flight.

1988: Wind Shear

Turbine-powered airliners with 30 or more passenger seats must carry equipment that warns of low-altitude wind shear. Guidance for recovery from wind shear is also required.

1991: Loran Gap Closed

Complete coverage of the US by Loran signals results from new station constructed to fill the "mid-continent gap."

1991: Mode S Interrogators

The first two Mode S systems are delivered to FAA. It's the beginning of the new radar beacon ground interrogator system that will eventually number 137 in U.S. airspace. Aboard aircraft, Mode S transponders will replace the ATCRBS system.

1993: GPS Approach Approved

Continental Express flies approved non-precision approach using GPS into two Colorado airports.

1994: MLS Halted

FAA will no longer develop the Microwave Landing System (MLS). Future effort at all-weather landing systems will be done with GPS.

Following this announcement, FAA cancels plans to pur-

chase 235 new ILS's (Instrument Landing Systems). Rapid development of GPS is the reason.

1994: Free Flight

In one of the most sweeping changes in air navigation, FAA begins study of "Free Flight." Aircraft will fly with greater freedom, enabling pilots to choose the most favorable routing. Air traffic controllers would intervene only to assure safety or avoid crowding in the airspace. Because of this, the term "air traffic controller" will become "air traffic manager."

A two-year trial of Free Flight begins in 1999 in Alaska and Hawaii.

1995: FANS Trial

FAA and Australia's Qantas Airlines complete first trials of new satellite-based communication, navigation and surveillance system recommended by the International Civil Aviation Organization (ICAO). Called "FANS" (Future Air Navigation System), it improves communications with aircraft flying in oceanic and remote areas. This is the beginning of a global changeover to the next-generation of air traffic control.

1996: Flight Recorders Expand

FAA proposes increase in the amount of information collected on Flight Data Recorders (FDR). The number of parameters would increase--from as few as 29 to as many as 88, depending on when the airplane was manufactured. Airlines would retrofit over about four years from the effective date of the rule.

1996: Enhanced Ground Prox

American Airlines is the first carrier to receive FAA approval for the Enhanced Ground Proximity Warning System (EGPWS). Installations are on all American's B-757's.

Review Questions

Chapter 2 A Brief History

2.1 Radio frequencies are measured in Hertz (Hz), after Heinrich Hertz. What was his contribution to communications?

2.2 What was the first system for marking cross-country airways? How was it limited?

2.3 What was the first instrument to enable pilots to maintain control of an airplane without seeing outside the cockpit?

2.4 What component led to the artificial horizon and autopilot? Name the developer of these early systems.

2.5 What type of transmitter sent the first radio message from an airplane to the ground?

2.6 What was the first radionavigation system for guiding airplanes?

2.7 Who was the pioneer who flew the first instrument flight, sometimes known as "blind flying," in 1929?

2.8 What system in Air Traffic Control replaced position reports by voice?

2.9 In 1980, manufacturers began designing airliners without a third crew member. What avionics development made it possible?

Chapter 3

VHF Com

Very High Frequency Communications

Communications move information in and out of an airplane for air traffic control, airline company operations and passenger services. The earliest “com” radios sent and received Morse code, then advanced to voice as technology became available. Today, voice messages are also headed for extinction, as digital information travels more efficiently on “datalink,” a technology spreading through aviation.

VHF-Com. Radios for communication may be labelled “Com, Comm, VHF-Com” or simply “VHF.” They receive and transmit in the VHF com band from 118.00 to 136.975 MHz. When a radio is a *navcom*

both communications and navigation are combined in a single case or housing. Because the com half transmits and receives, it is a “transceiver.”

The VHF band is under great pressure because of the growing number of aircraft. Frequencies are assigned by international agreement and difficult to obtain because many non-aviation services compete for limited space in the radio spectrum. These include public-safety (police, fire, emergency medical and other government activity). VHF is also in demand by “landmobile” services such as taxi, and delivery vehicles. As a result, avionics engineers have developed new techniques for expanding communications inside the existing VHF aviation band.

Splitting. One method for squeezing in more channels is “splitting.” As the accompanying chart shows, the VHF band has been split four times, resulting in an increase from 90 channels to over 2,280. This became possible with advances in digital signal processing, especially to make the com receiver respond very selectively to the new, narrow channels.

A large number of old-technology avionics could not operate with such tight spacing and, in 1997, radios with 360 channels or fewer were banned (see chart).

VHF Data Radio. In the coming years, there will be a dramatic drop in the number of voice transmissions on the VHF aircraft band. It is due to the rise of



Three VHF com radios are often carried aboard airlines; the antenna locations are shown above. VHF com 1 and 2 are for communicating with air traffic control. VHF com 3 operates in the ACARS system for what is commonly called “company communications.”

Acceptable VHF Com Radios

NO. OF CHANNELS	SPACING	ACCEPTABLE?	NOTES
90	100 kHz	No	January 1, 1997 banned radios with 360 or fewer channels
180	50 kHz	No	The increase from 180 to 360 channels resulted when the band was expanded from 126.90 to 135.9 MHz
360	50 kHz	No	Doubling of channels resulted from "channel splitting" (moving frequencies closer together).
760	25 kHz	Yes	Again channels were split, but new technology produced selective receivers which could separate close-spaced channels. Also, another megahertz was added to the band, providing 40 more channels.
2280	8.33 kHz	Yes	Further channel splitting tripled the channels to accommodate increasing air traffic. This spacing, 8.33 kHz, was first used in Europe, where frequency congestion became critical.

"datalink," where messages are sent and received in digital coding. The human voice delivers information at a slow rate---about 300 words per minute. Compare this to an e-mail message building on a computer screen. Three hundred words appear in about one-tenth of a *second!* Not only will datalink take one channel and split it more than four ways, it operates faster, and eliminates misunderstood words.

VDR. Airliners and other large aircraft are equipping with a new generation known as VDR, for VHF Data Radio. Because many years are required to transition to a new system, the VDR must operate on both existing and future systems.

Voice. This is the traditional air/ground communications where the pilot talks over a microphone. It is known as AM, or amplitude modulation.

ACARS. An automatic system that reports via VHF radio to an airline company when its aircraft take off and arrive, and carries messages about company operations (described in the next chapter).

VDL. Yet another mode is VDL, for VHF datalink. Many airliners have equipped with VDL because their wide-ranging flights must be prepared to communicate with systems everywhere.

VDR Radio

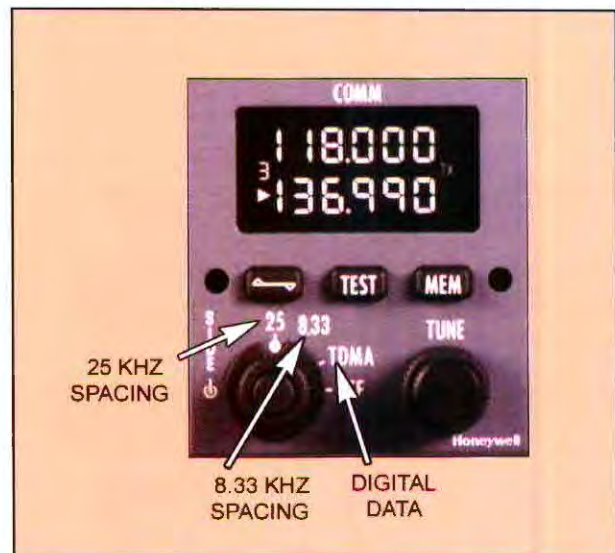

Control-display head for the VDR (VHF data radio). The knob at the lower left enables the pilot to select either channel spacing; 25 kHz or the newer 8.33 kHz. The next position is "TDMA" which can send digital voice and data.

Basic VHF-Navcom Connections: General Aviation

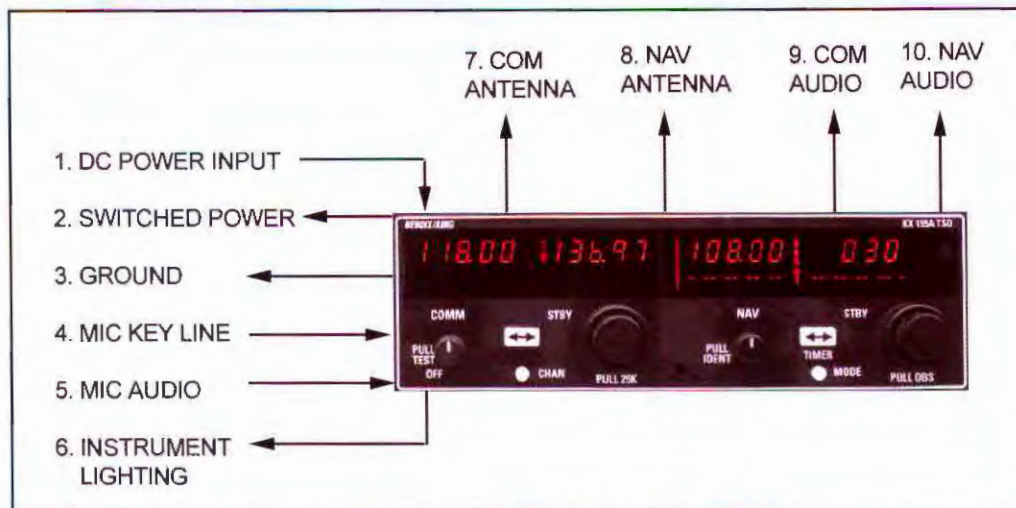

1. DC Power Input

Depending on the airplane's electrical system, this is primary power to the radio; 14- or 28-volt DC. It from a circuit breaker or fuse designated for a navcom. In some diagrams, DC power input is also called the "A" lead.

2. Switched Power

When the radio is turned on, this connection sends power from the radio to certain accessories, such as an external indicator that displays navigation information. An example is the VOR instrument that displays left-right, up-down steering commands.

3. Ground

The negative side of the electrical system, it can be any part of the airplane's metal structure that goes back to the negative side of the battery.

In composite (non-metal) airplanes, the ground is a "bus bar," or heavy copper wire or braid that extends the negative battery lead through the airplane.

4. Mic Key Line

Turns on the transmitter when a microphone button is pressed. The button may be on the mike, or mounted on the control yoke. Releasing the button switches the radio back to receive.

5. Mic Audio

This is the voice signal from the pilot microphone brought into the radio through a microphone jack or audio panel. Mic audio is applied to the transmitter,

and drives the pilot intercom or passenger address system.

6. Instrument Lighting

At night, the pilot may dim lights on the panel with one control. When this connection is wired to the dimmer, radio lighting is controlled along with all other illumination.

7. Com Antenna

Coaxial cable that runs to the VHF com antenna.

8. Nav Antenna

Coaxial cable to the VOR nav antenna.

9. Com Audio

Audio received from an incoming signal. In simple installations, this line connects to the pilot's headphone jack. Audio at this point is "low level," meaning it can only drive a headphone, and not a cabin speaker. Although some radios have built-in amplifiers, many aircraft add an audio panel. It not only provides amplification for the cabin speaker, but boosts and mixes low level audio from other sources.

10. Nav Audio

This enables the pilot to listen to and identify navigational signals, which broadcast an ID in Morse code and voice.

VHF-Com System

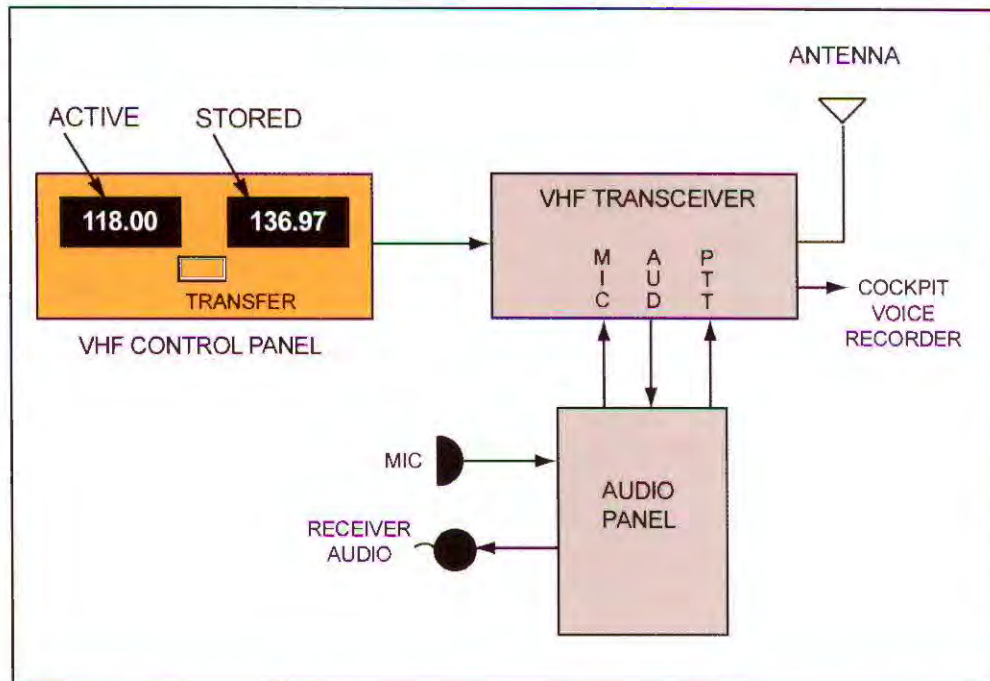

A com radio typically found in airliners and large aircraft. The pilot operates the VHF Control Panel, while the main unit of the VHF transceiver is in a remote electronics bay.

Two frequencies may be selected at one time; the *active* channel sends and receives, the *stored* channel remains inactive. When the transfer button is pressed, the two channels exchange places.

The Audio Panel connects pilot microphone and headset or loudspeaker. "PTT" is the push-to-talk button that switches the

radio between transmit and receive. The button is on the microphone or the control yoke.

The transceiver also provides an audio output to the Cockpit Voice Recorder to retain radio messages in the event of a safety investigation.

There are usually three VHF com radios aboard an airliner. One radio, however, is operated in the ACARS system, as described below.

Third Com Radio

This is the same as the other two com radios, except for modifications to operate on ACARS (Aircraft Communication and Reporting System) described in a later chapter. There is no pilot control panel because the frequency is pre-set to an assigned ACARS channel. ACARS automatically receives and transmits messages about company operations.

A pilot may also use voice on this radio through the mic and receiver audio connection.

VHF com radios in large aircraft typically operate from a 28 VDC power source. The transmitter is often rated at 25 watts of radio frequency output power.

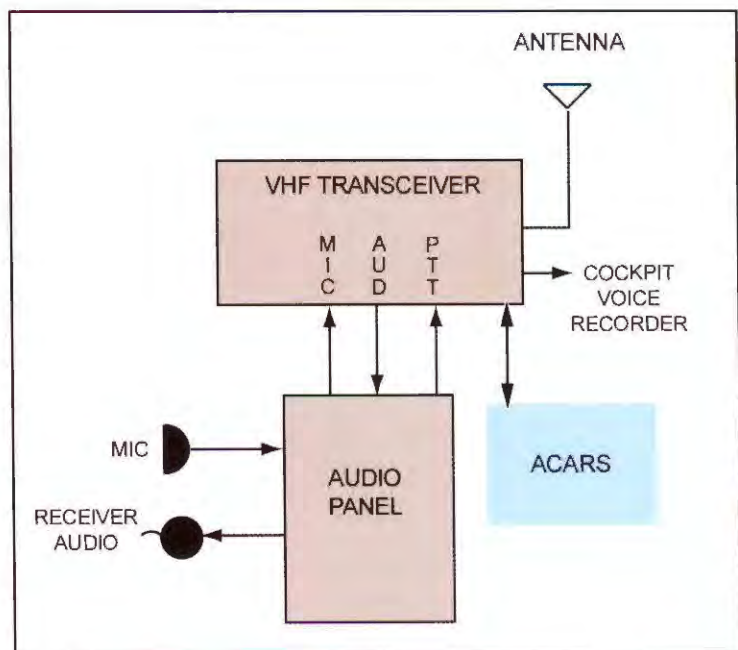

VHF-Com Control Panel

Typical airline control head for one VHF transmitter-receiver (transceiver). The pilot is communicating on the left display; the frequency transfer switch is pointing left. He has stored the next frequency on the right side. A flip of the transfer switch activates the next frequency. This panel-mounted unit controls a remote transceiver in the electronics bay.

The "Com Test" button at the bottom disables the automatic squelch. This allows atmospheric noise to be heard, which is an approximate test of whether the radio is operating.

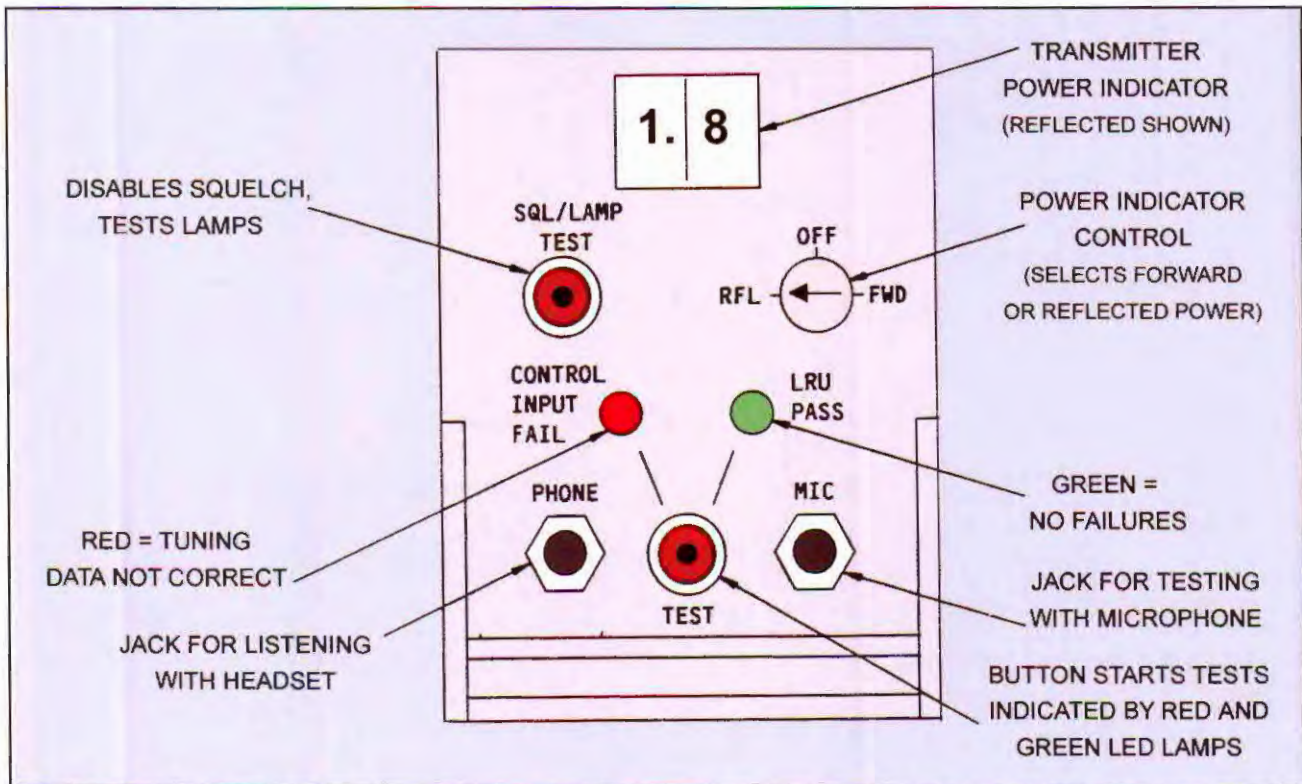
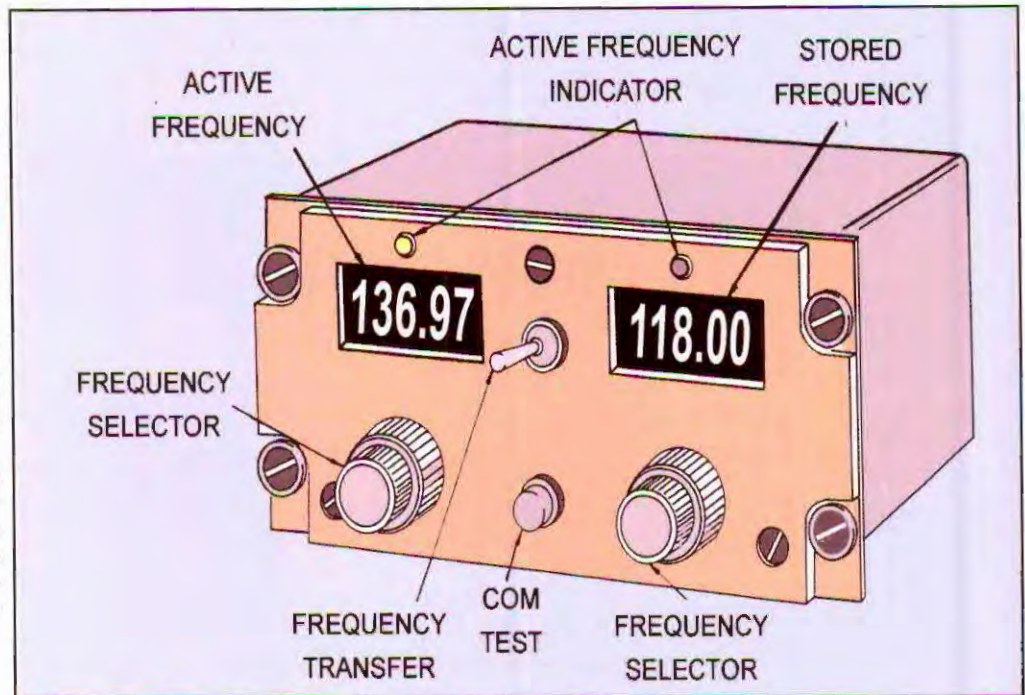

Located in the electronics bay, the VHF transceiver is remotely tuned by the control head in the instrument panel. This LRU (line replaceable unit) has several test features built in. The indicator at the top shows transmitter power in the forward direction (toward the antenna) or power reflected back to the transmitter. If

reflected power is high, there's a problem in the antenna or cable. This is covered in the chapter on test and troubleshooting. The jacks at the bottom enable the technician to talk and listen while testing in the electronics bay.

“Splitting” VHF Channels

Almost every decade for the last 50 years, VHF com channels have been “split,” dividing the space occupied by one frequency. Another way of viewing it is that channels are moved closer together within the same band.

The first aircraft radios had “200 kHz” spacing. (Note that “200 kHz” can be written as “.2 MHz” by moving the decimal three places to the left.) Thus, the dials of early com radios appeared as:

120.....120.2.....120.4.....120.6.....120.8.....etc.

This spacing divided the VHF com band into 70 channels. As aviation grew, the band was increased in size and 20 more channels were added (still with the 200 khz spacing).

But aviation was growing and demanding more frequencies. Fortunately, the avionics industry was also advancing with techniques that made receivers more “selective,” enabling them to separate two channels that are closely spaced. The progress of splitting went like this:

Spacing	No.of Channels
200 kHz	90
100 kHz	180
50 kHz	360
25 kHz	760
8.333 kHz	2280

For channel-splitting to work, transmitting frequencies are held to tight tolerances to avoid drifting and causing interference to other channels. Because early radios could not comply, they were outlawed on the aviation bands. Most radios now operate on 25 kHz and 8.333 kHz spacing.

The last split, to 8.333 khz, marks the beginning of a new-type com radio that handles both voice and digital data. It is VDL (Very High Frequency Data Link). Using digital signals, each 8.333 frequency can operate simultaneously with up to four channels of information; four voice and two digital messages.

Radio Management System



Chelton Avionics

CONTROL-DISPLAY UNIT RECEIVER/ TRANSMITTER NAV (VOR) RECEIVER ADF RECEIVER DME TRANSPONDER

A Radio Management System eliminates numerous knobs, buttons and separate control heads for operating com and nav radios. It’s less of a workload to operate and saves space on the instrument panel. The pilot sees only the control-display unit (at the left) and selects or stores frequencies, transponder

codes, etc. All the other units are mounted in remote racks and are controlled through a databus (ARINC 429).

This system, the Chelton RMS 555, is used by corporate, regional airline and military aircraft.

Review Questions

Chapter 3 VHF Com

- 3.1 What frequencies define the Very High Frequency (VHF) band?
- 3.2 What is the frequency coverage of the VHF com band?
- 3.3 What is “splitting” channels?
- 3.4 What development greatly reduces the number of voice reports on VHF com?
- 3.5 What is the narrowest spacing for channels in the VHF com band?
- 3.6 What is the purpose of a mic key line?
- 3.7 A typical com radio has two frequency displays; one for the _____ frequency, the other for the _____ frequency.
- 3.8 What is the purpose of a squelch?
- 3.9 What function does the “com test” control provide?
- 3.10 Where is the LRU (line replaceable unit) for a com transceiver of a large aircraft located?
- 3.11 What is the benefit of a radio management system?
- 3.12 What is the third VHF com radio of an airliner often used for?

Chapter 4

HF Com

High Frequency Communications

When an airplane leaves the coastline for a transoceanic flight, it moves into a polar region or ventures over a remote area, it loses VHF communications. VHF signals are line of sight and cannot curve over the horizon. For long-range flight, the airplane switches to HF---high frequency---communications.

In a band from 2-30 MHz, HF radio travels 2000-6000 miles by “skipping” through the ionosphere, an electrical mirror that reflects radio waves back to earth.

HF has never been a pilot’s favorite radio. Early models didn’t have the reliability of VHF because the ionosphere is always changing---between day and night and season to season. It is struck by magnetic storms from the sun which repeat over an 11-year sunspot cycle, interrupting communications for hours, even days.

The cure is the eventual elimination of HF radio by satellite communications. Nevertheless, thousands of aircraft will continue to fly with HF for decades before the transition is complete. Fortunately, HF has enjoyed several improvements.

Early HF radios were difficult to operate. Most antennas for aircraft measure from inches to several feet long. The length tunes the antenna to one-quarter wavelength, which is standard for aircraft. A VHF an-

HF Control-Display



Control-Display for an HF radio for General Aviation. With output power of 150 watts (Single Sideband, or SSB) it tunes 280,000 channels. An antenna coupler (remotely located with the receiver and transmitter) automatically tunes the antenna when the microphone button is pressed. Some models, like this one, have a “Clarifier” control (lower left) to fine tune the incoming voice.

The radio also solves the problem of hunting for a workable frequency under changing ionospheric conditions. With circuit called “automatic link establishment” it searches for the best available channel. This model is the Bendix/King HF-950. Weighing about 20 lbs, it is also used by helicopters, which often fly in remote areas beyond VHF communicating range.

tenna at 120 MHz, for example, has a quarter-wavelength of only two feet, easy enough to mount as a small whip or blade on the airframe. But as operating frequency goes lower, wavelength grows longer. A quarter-wave HF antenna on 2 MHz would have to run

HF System

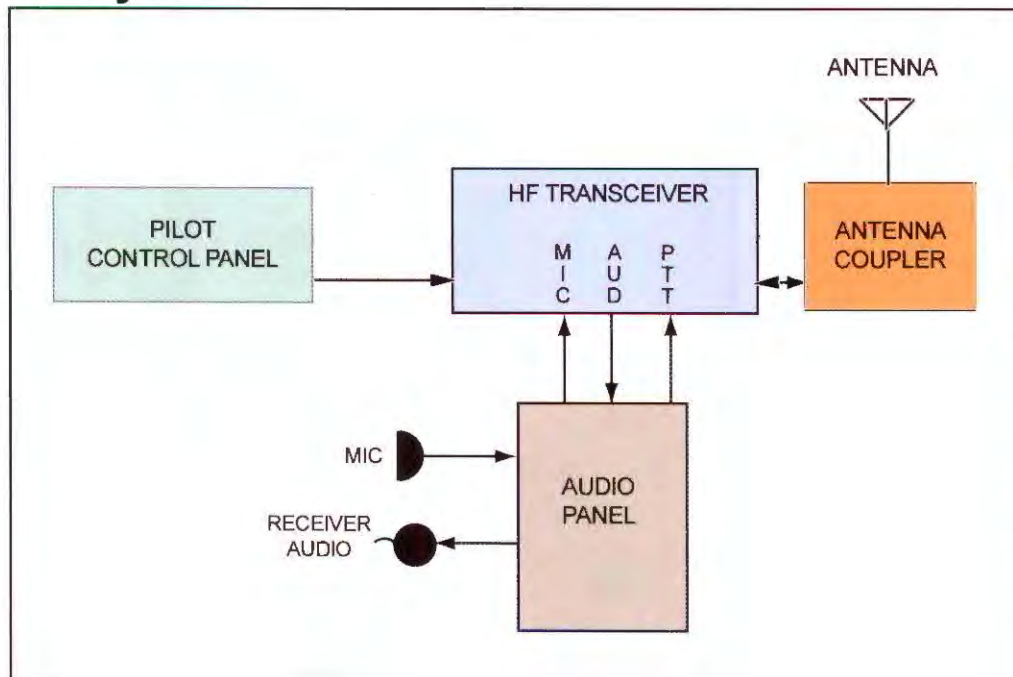

When the pilot keys the transmitter on a new channel, a 1000 Hz (audio) tone is modulated onto the radio wave and sent to the antenna coupler. This enables the coupler to match the antenna to any HF frequency. A tone is used because, unlike voice, it produces a steady radio-frequency output for the coupler to measure. Antenna tuning usually takes less than four seconds.

over 100 feet long!

Radio pioneers solved this with a “trailing wire” antenna—reeling it out to float behind the airplane. If radio conditions changed, they hunted for a new frequency and changed antenna length. They also had to manually adjust an antenna tuner.

A breakthrough happened when Arthur Collins (founder of a company that produces air transport avionics) came up with an improvement called “Autotune.” It is a tuning unit that matches a short, fixed antenna on the airplane to the wavelength of any HF frequency. It’s done automatically when the pilot selects a channel.

The concept of automatic antenna tuning is based on “reflected power.” If an antenna and antenna tuner are adjusted for, say, an operating frequency of 12 MHz and the pilot changes to 5 MHz, there will be a large electrical mismatch between the antenna and feedline from the transmitter. This causes radio frequency power to reflect back from the antenna and be lost. The Autotune system measures the reflected power and operates tuning elements in the antenna coupler to reduce the reflection to the lowest possible value. (The concept of reflected power reappears in the chapter on test and troubleshooting, where it’s called VSWR, for voltage standing wave ratio.)

In today’s HF radios, changing frequencies and retuning the antenna can occur in less than a second

from the time the pilot turns the channel selector.

Automatic HF antenna tuning, which greatly reduced pilot workload, was followed by a development that improved HF radio’s ability to avoid fading signals and poor radio conditions caused by variations in the ionosphere.

SSB HF radio originally transmitted in the AM (amplitude modulation) mode, the same as AM broadcast radio today. An AM transmitter generates three components; a radio-frequency (RF) carrier, an upper sideband and lower sideband. The audio (or voice) is found only in the sidebands. This was discovered in the 1920’s, along with the observation that the RF carrier served only to create the sidebands inside the transmitter. The carrier doesn’t “carry” the sidebands. Sidebands travel just as well with or without a carrier. Because the sidebands lie just above and below the carrier frequency, they are termed USB and LSB (for upper and lower).

In regular amplitude modulation, more than two-thirds of the transmitter power is lost in the carrier. What’s more, the upper and lower sidebands carry the identical information. So all that’s required for transmitting the voice is a “single sideband.”

It took several decades for the electronics industry to develop stable transmitters and receivers and sharp filtering to make “SSB” practical. As a result, today’s

HF-SSB transceiver places nearly all transmitter power into a single sideband, producing a powerful signal that punches through worsening ionospheric conditions.

HF Datalink. Despite the improvement of SSB, pilots were not yet completely satisfied; HF still didn't provide the solid reliability of VHF communications. In seeking further improvement, the avionics industry considered digital communications to handle routine messages. The first experiments failed as researchers discovered that digital signals barely survived the turbulent ride through the ionosphere. Too many digital bits were lost in transmission.

At about this time, the first communications satellites were rising in orbit, offering solid long range com-

munications to the aeronautical industry. This threatened to kill further development in HF, but the airline industry wasn't ready for "satcom." Satellite installations at the time proved too expensive for many carriers, which motivated researchers to design a workable HF datalink.

Today, HF datalink is a reality. The new radios perform "soundings"---listening for short bursts of data from ground stations around the world. A link is established to the best one for communications. If conditions deteriorate, the radio automatically searches for, and switches to, a better channel. If there are errors in transmission, the ground station senses them and automatically calls for repeats until the data is correct.

Remote Line Replaceable Units (HF)



Three remote-mount boxes for an HF radio installed on business aircraft. They are controlled by the pilot on the flight deck.

The radio tunes 280,000 channels and stores 99 user-programmable frequencies (for quick retrieval). For sending distress calls, the international maritime distress frequency on 2.182 MHz is pre-programmed. The model shown here, the Primus HF-1050, is upgradeable for HF datalink.

Honeywell

HF Control Panel: Airline

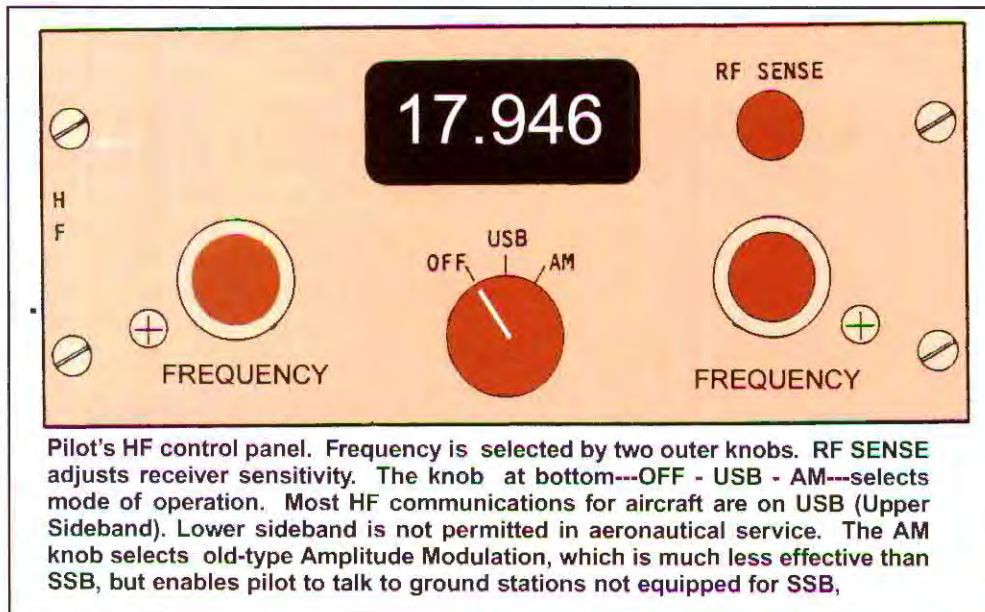

HF Transceiver

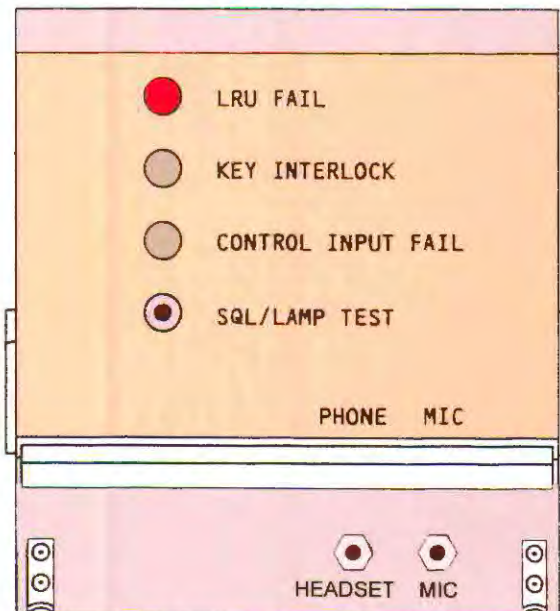

Mounted in an electronics bay, the HF transceiver is operated from the pilot's HF control panel. It has several provisions for testing. Three lights show system status (the red lamp is indicating "LRU FAIL," meaning this transceiver, a line-replaceable unit). The button "SQL/LAMP" is pressed for two tests; all lamps should light, and the squelch is disabled. During a disabled squelch, the technician should hear atmospheric noise, which is an approximate test that the receiver is working. He can also plug a microphone into the "MIC" jack and talk on the radio during troubleshooting.

The transmitter in airline service is usually rated at 400 watts of radio frequency power during single-sideband (SSB) transmission; 125 watts in the AM mode.

Advantages of HF Datalink

- Lower Pilot Workload
- Shorter Message Transmission Time (less than 3 seconds vs more than 1 minute)
- Channel Access Time (less than 60 seconds vs up to 10 minutes)
- Less Operational Training for Flight Crew
- Data Relieves Congestion on Voice Frequencies
- Automatic Selection of Frequency and Data Rates
- Voice Is Prone To Human Error and Interpretation
- Data Detects Errors and Automatically Retransmits
- Data Extracts Signals in Noisier Environments (3dB/10dB)
- Increased HF Traffic Capability
- Assured Communication Link Automatic Air/Ground HF linkage With Less Acquisition and Message Cost (Compared to Satcom)
- Improved Voice/Data Quality
- Data Link Messages Are Not Written or Sensitive to Verbal Language

(Based on a Honeywell report)

HF Antenna Coupler

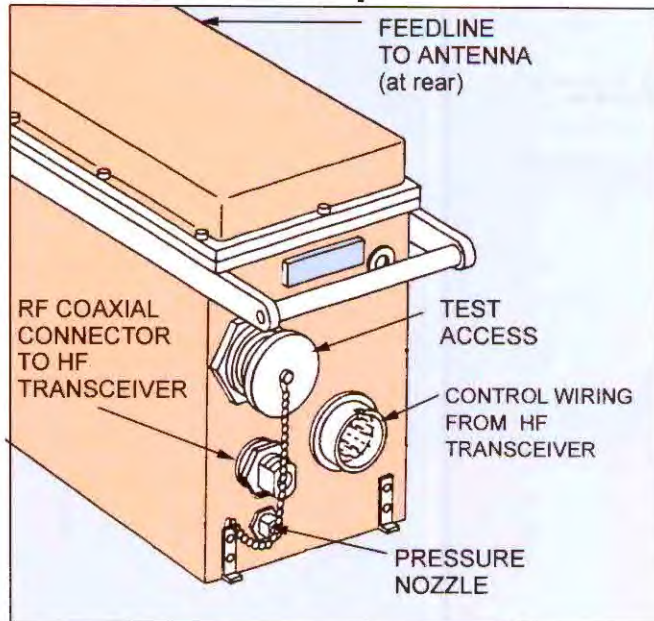

Mounted below antenna in rudder fin, HF antenna coupler tunes antenna to the frequency in less than 4 seconds after pilot selects a channel.

Pressure Nozzle at the bottom pressurizes the coupler enclosure. Otherwise, low air pressure at altitude would cause high voltage in tuning coils to arc over and short.

HF Antenna Mounting

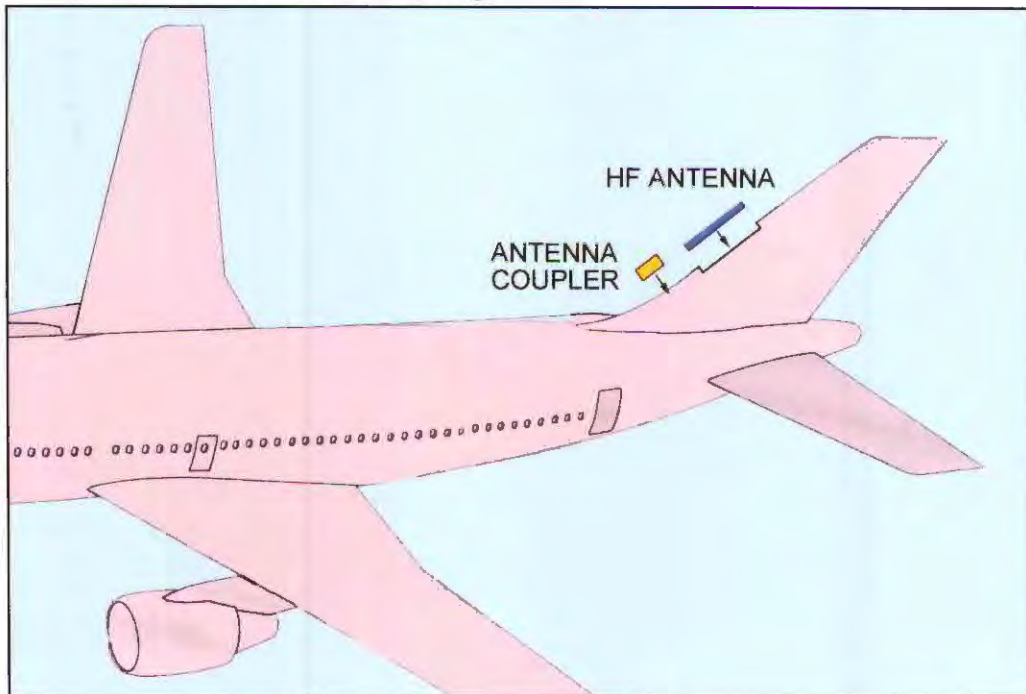

The HF antenna on a typical airliner is located in the vertical tail fin. The radiating antenna is inside a U-shaped fiberglass leading edge. The antenna coupler is just below, inside the rudder fin. The coupler matches any HF frequency (2 - 30 MHz) and sends it through a feedline to the antenna.

Review Questions

Chapter 4 HF Com

- 4.1 Why are High Frequency communications not as reliable as those of VHF?
- 4.2 What is the advantage of "Autotune."
- 4.3 Why is SSB (single sideband) more efficient than conventional AM radio?
- 4.4 What made HF datalink successful?
- 4.5 What are three major components of an HF line-replaceable unit (LRU)?
- 4.6 Name two advantages of HF datalink?
- 4.7 What is the purpose of an HF antenna coupler?
- 4.8 Where is the HF antenna mounted on many airliners?

Chapter 5

Satcom

Satellite Communications

Satcom provides communications between aircraft and ground through most of the world. Free from atmospheric interference and limited bandwidth, it is the replacement for High Frequency (HF) as the band for long-range communications. Satcom signals penetrate the ionosphere without bending or reflecting and are unaffected by electrical noise or weather. As satcom avionics build through aircraft fleets, they will eventually replace VHF com, as well. The signals of satcom are digital, not only for data communications, but voice, as well. This means voice messages can be encrypted for security.

Satcom is also the foundation for the next generation of air traffic control. After a half-century of aircraft confined to narrow routes and tracks, a changeover is beginning to a new architecture known as FANS, for Future Air Navigation Systems. More airplanes will fly safely within the same airspace under a concept known as "Free Flight." Satcom makes it possible, as well as providing information, entertainment and other services for passengers in the cabin.

Inmarsat

The London-based organization providing satellites and ground support is Inmarsat (International Maritime Satellite). Consisting of more than 60 member



(Inmarsat)
A Ground Earth Station communicates with orbiting Inmarsat satellites, which relay messages to and from aircraft. The Ground Earth Station receives and sends those messages through telephone companies and other telecommunications services throughout the world.

Generations of Inmarsat Spacecraft

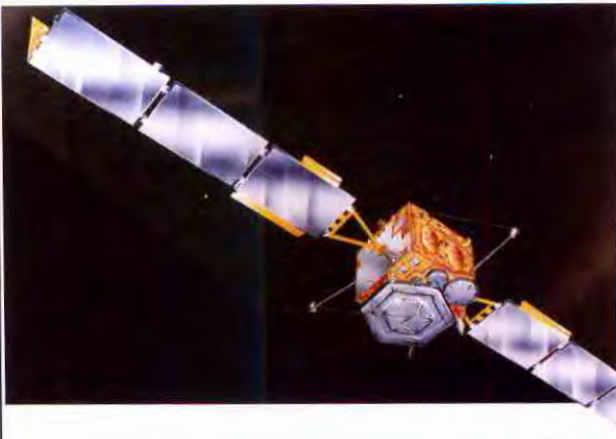

Inmarsat-2 (called I-2) was launched in 1991 after the first generation raised the demand in aviation for more satellite services. I-2 provides four times more capacity than I-1. The constellation consists of four active satellites, with four spares in orbit to assure continuous service.

All satellites are monitored by control centers on the ground. As gravity causes a satellite to drift from orbit, the vehicle's attitude and orbit are adjusted by a control station. When the satellite moves into the dark side of the earth at night, its solar cells are eclipsed. Batteries provide power in the dark. Controllers monitor the battery backup to be sure satellite power is sufficient.

Inmarsat-3 has ten times the capacity of I-2. Each of the four spacecraft has one global beam which covers a wide area of the earth. Each also has 7 spot beams which concentrate power over a narrower area (usually where demand is high, along heavily traveled routes). Backup for I-3 is the previous generation of I-2 spacecraft.

The next constellation is I-4, designed to be 100 times more powerful and have ten times the communications capacity.



countries, it provides the space segment known as "Inmarsat Aero". Using four satellites, it provides two-way voice and data (fax, Internet, e-mail, ATC) over most of the world. Because the satellites hover over the equator, their beams cannot extend into the North and South Pole regions. Future systems will add polar orbits to fill in these limited areas. The four Inmarsat satellites:

- Pacific Ocean Region (POR)
- Indian Ocean Region (IOR)
- Atlantic Ocean Region West (AOR-W)
- Atlantic Ocean Region East (AOR-E)

Each satellite is backed up with a spare orbiting in same vicinity. The other two major components of the satcom system are:

Ground Earth Station (GES). These radio stations around the world operate large dishes for communicating with satellites. They receive messages sent to a satellite by an aircraft, then pass them to a telecommunications company for relaying them to any telephone or data terminal in the world.

If the message is intended for an aircraft in flight,

the ground earth station receives it through telecommunications networks and beams it up to a satellite for relay to the airplane.

Aircraft Earth Station. This is the avionics system aboard the aircraft for communicating with satellites. It must conform to Inmarsat standards and the specification for ARINC 741.

Satcom antennas. A component of the airborne system is the antenna, which must always aim directly at the satellite (to receive all of its services). Although Inmarsat satellites appear never to move (they are in geostationary orbit), the airplane often cruises over 500 mph, rapidly changing position. This is solved by a beam steering unit on the airplane that operates a motor-driven antenna or an electronic system known as a "phased array." Consider the satcom antenna categories:

Low Gain. Various communications via satellite require a different amount of power. A message consisting only letters and numbers moving at a slow rate (300-1200 bits per second) uses relatively little power and can operate on a "low gain" antenna on the airplane. The antenna is simple, little more than a blade, and picks up signals from any direction.

Inmarsat-Aero System

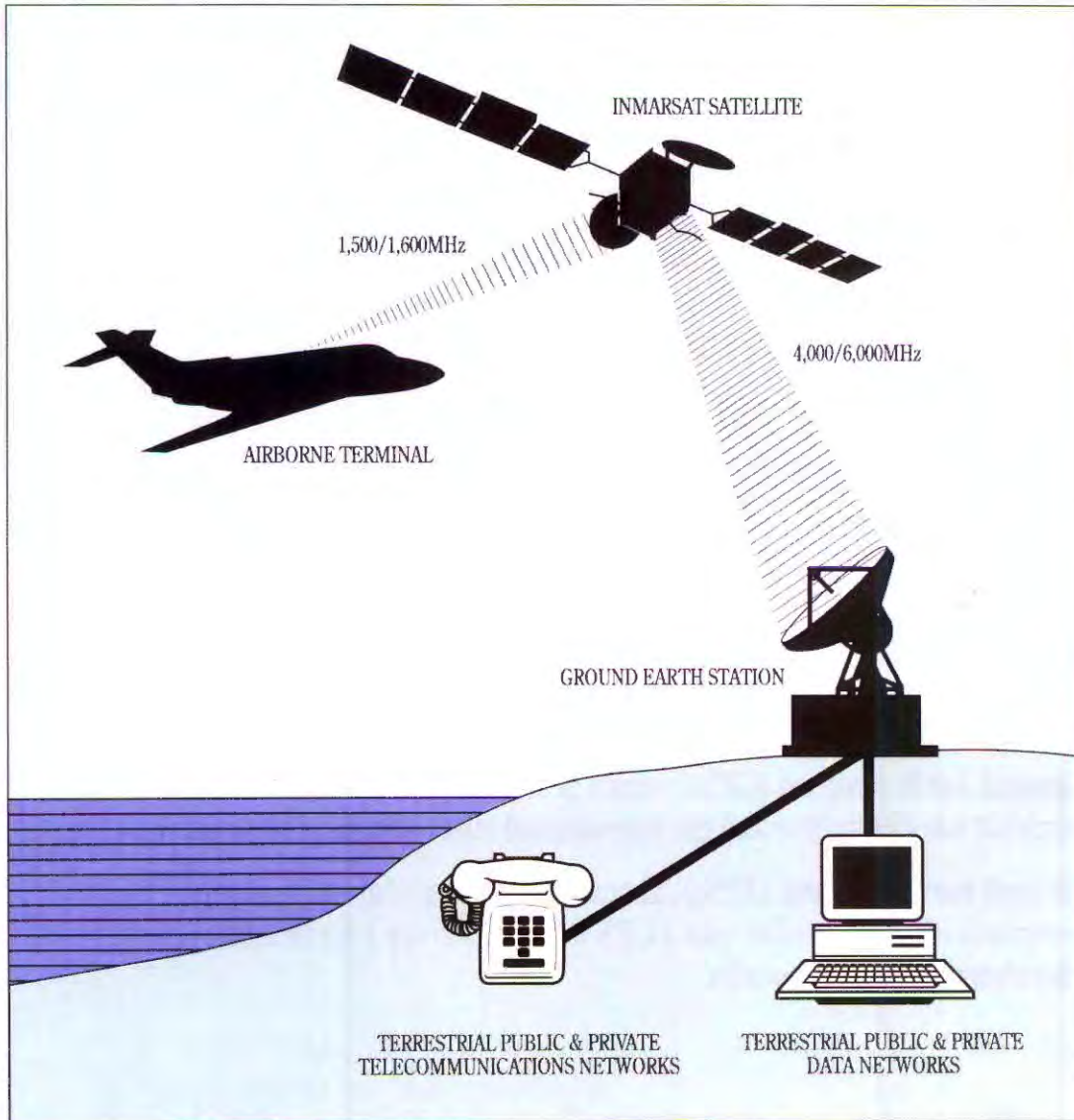

The system for satcom consists of three basic elements; satellites (space segment), airborne avionics (aircraft earth station) and the connection into telecommunications networks (telephone companies, for example.) This last element is known as the ground earth station.

Four Inmarsat satellites cover nearly all the

world (coverage falls off at the poles). Four additional satellites are in orbit as spares, ready to take over during a malfunction.

An airplane communicates with satellites, not ground stations. There are ten ground stations throughout the world for relaying aircraft communications into telecommunications networks.

High Gain. This antenna supports the full range of satcom services, which require more power than is possible with a simple blade. The “high gain” antenna is more complex and expensive. The improvement in power (“gain”) is achieved in two ways. First, the antenna is made highly directional with additional elements to focus signals into a beam. The narrow beam, however, must always aim directly at the satellite.

Steering the beam is accomplished in two types of high gain antenna, shown on the following pages. One is the electromechanical; the antenna is rotated in azimuth and elevation by electric motors (much the same

as done in an astronomical telescope).

An airplane in cruise is always moving with relation to the satellite. To keep the high gain antenna pointing toward the satellite, the airborne satcom steers the beam using information from the airplane’s navigation system. As shown in the illustration, the electromechanical high gain antenna fits in the tail cap of the airplane.

Conformal. The second type of high gain antenna is the “conformal,” which fits the curve of the fuselage and protrudes less than a half-inch. The radio signal is shaped into a narrow beam and aimed electronically. Inside the conformal radome are many small micros-

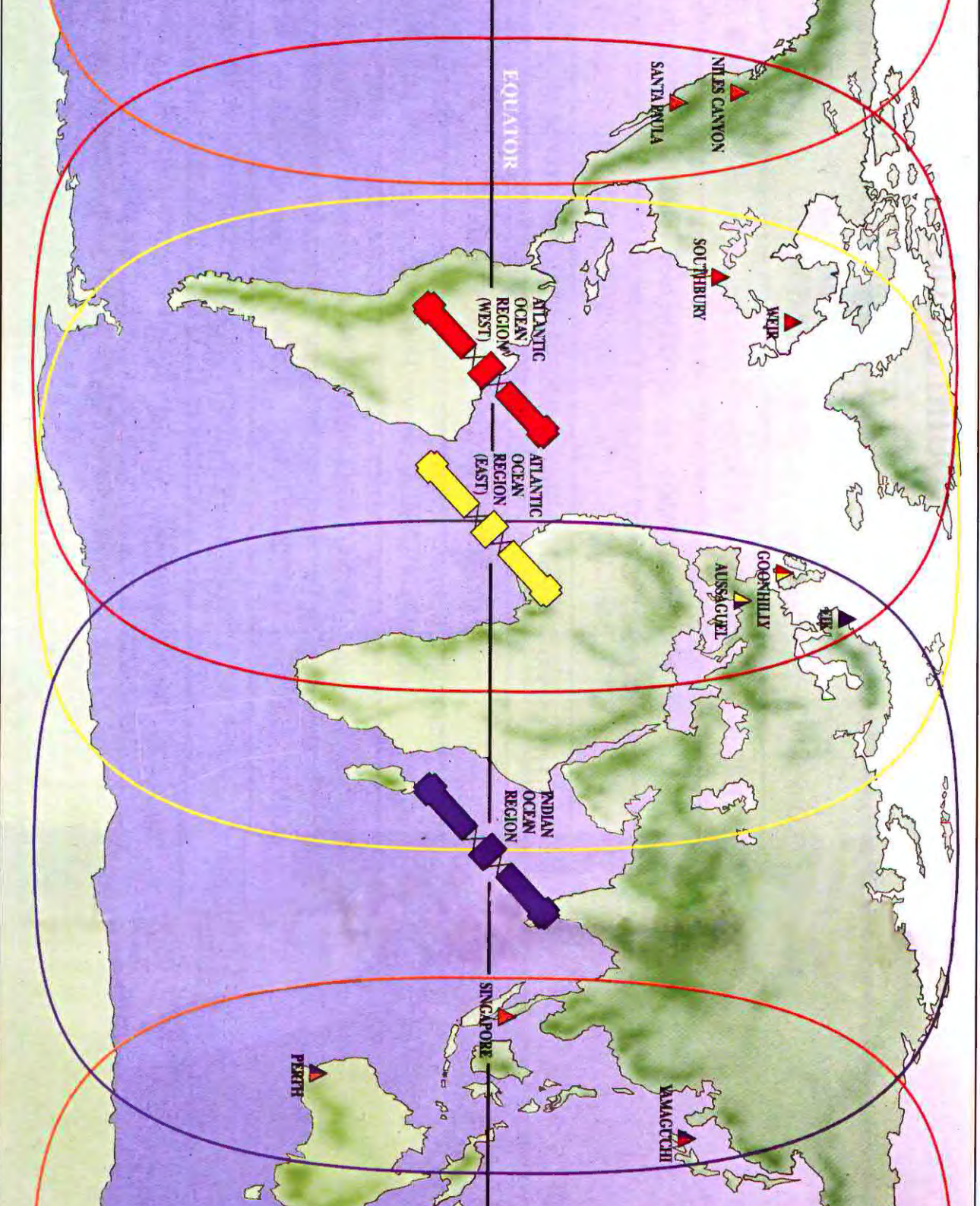

Space Segment

Four Inmarsat satellites provide global coverage. All are directly overhead the equator (at 22,300 miles, or 36,000 kilometers) and in geostationary orbit. Because they com-

plete one orbit in 24 hours (also one rotation of the earth), the satellites appear to remain fixed in position. Each satellite is backed by a spare orbiting nearby.

trip antennas. The beam steering unit adjusts the signal in each microstrip antenna so its energy adds or subtracts according to a pattern that forms a beam. The energy is focussed and steered in a technology known as "phased array."

Either conformal or electromechanical, high gain antennas support all satcom services. Data rates begin at 10.9 kilobits per second, which handles fax, voice and high speed data, but this rate is increasing.

Swift64. A recent service is Swift64, which communicates at 64 kilobits. With a high gain antenna on the airplane, this rate accommodates such wideband services as Internet, e-mail and video conferencing.

Intermediate Gain. A more recent development affects the gain of signals from the space vehicles. The first two satellite generations broadcast "global" beams to cover as much of the earth as possible---and the latest generation still does. Recent satellites, however, add "spot beams," which concentrate power over a smaller area (but total earth coverage is still about 75%). Because of this added power, a third type of aircraft antenna emerged; the "intermediate gain" type, which falls between the low and high gain models. It is less costly and simpler, yet provides a wide range of satcom services.

Cell Phones in the Cabin



Inmarsat

Cell phones were banned in aircraft because they contact too many ground stations simultaneously while at altitude. But intense passenger interest is producing new systems that will almost certainly be adopted. They work with the passenger's own cell phone and billing is done on his regular cell phone account.

The technology places a base station aboard the aircraft that commands cell phones to operate at low power and avoid raising regular ground stations. The base station relays the calls through satellites, then into the regular landline telephone system.

Ground Earth Station (GES)

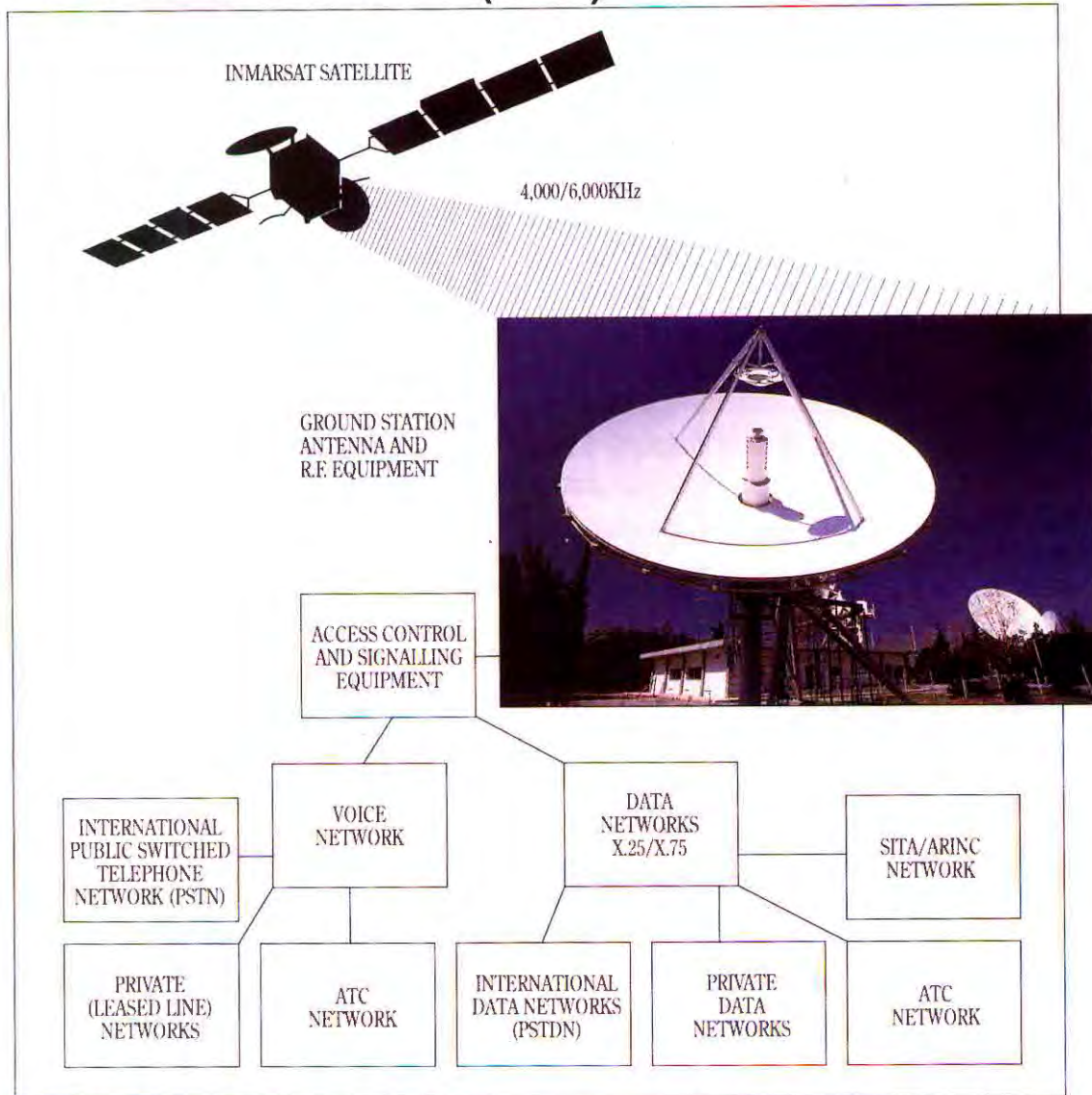

Inmarsat

Ten ground stations like this one are located around the world for communicating with aircraft via satellite. The ground station connects to international telecommunications networks to route calls and messages to any telephone, fax machine or data terminal in the world.

The station's dish antenna is typically 10 meters in diameter and operates in the sat-

com band between 4 and 6 GHz.

Voice sent via satellite uses "codec," for digital voice coding and decoding. Digitizing the voice reduces error in transmission and speech is high in quality.

The various blocks seen at the bottom of the illustration reveal a wide range of satellite services for aircraft, including air traffic control, passenger telephone, airline operations and data.

Aircraft Earth Station (AES)

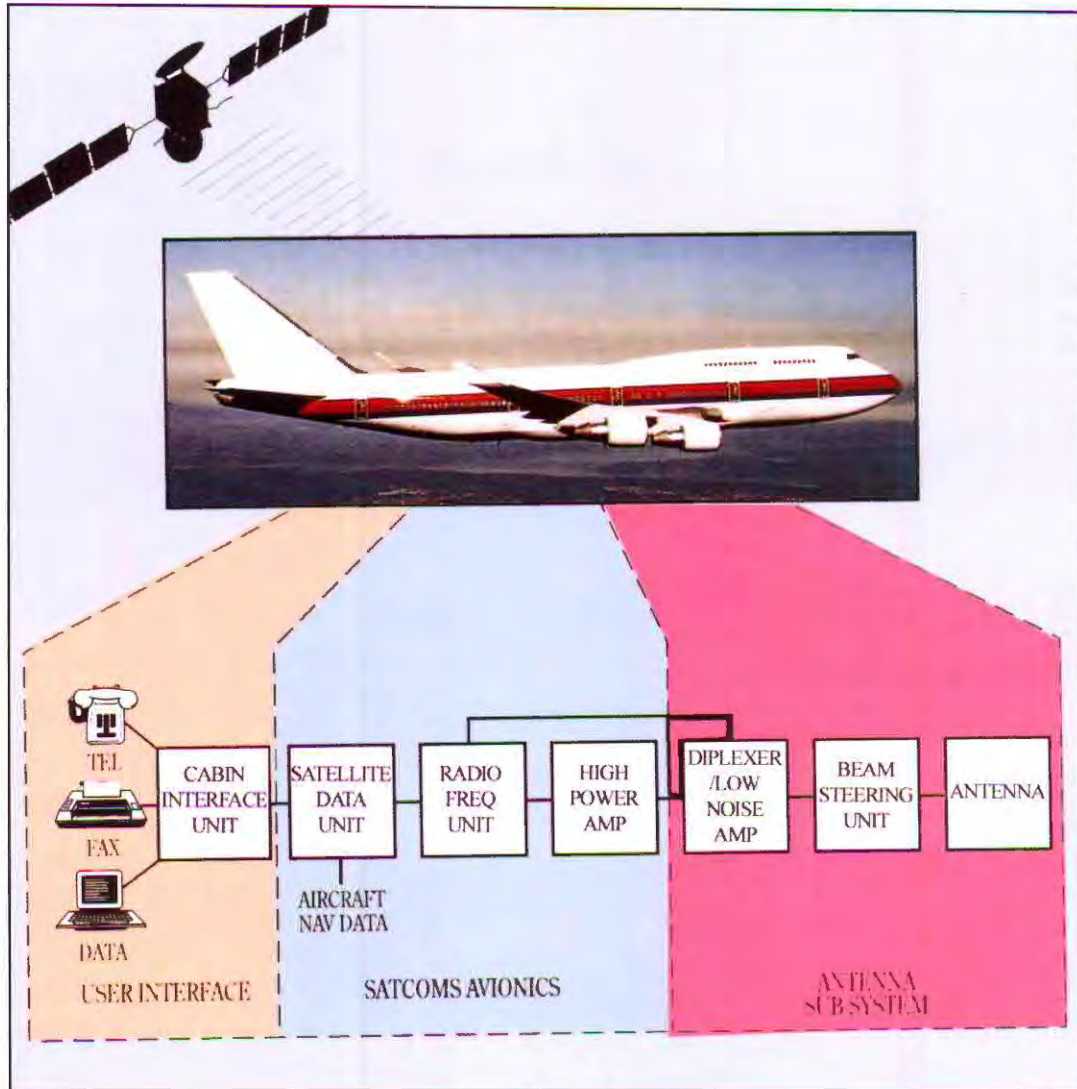

Inmarsat

Avionics aboard the aircraft for communicating via satellite are known as the Aircraft Earth Station. It sends and receives radio frequency signals to and from the satellite in the L-band (1.5-1.6 GHz). It provides interfaces to various systems aboard the aircraft for voice, data, fax, video, etc.

This equipment conforms to ARINC 741, as well as standards from Inmarsat, the satellite service provider.

The basic components of an Aircraft Earth Station:

Satellite Data Unit (SDU)

As the heart of the airborne equipment, the SDU interfaces with the airplane navigation system. Airplane location is required to steer antennas, select satellites and report position to air traffic services.

The satellite data unit also processes all message data, protocols and digital coding and decoding.

Radio Frequency Unit (RFU)

For data ready for transmission, the RFU converts sig-

nals from an intermediate frequency up into the L-band. They are sent to the High Power Amplifier (HPA) for transmission to the satellite.

During receive, the signal from the antenna first passes through a Low Noise Amplifier, then is applied to the Radio Frequency Unit. Signals are converted down to a lower, or intermediate, frequency and sent to the Satellite Data Unit.

The Low Noise Amplifier boosts the radio frequency signal received from the antenna.

Beam Steering Unit (BSU)

For high gain antennas, the beam steering unit keeps the elements pointed at the satellite as the airplane position changes. Position information is received from the Satellite Data Unit.

The antenna may be steered in two ways. For electro-mechanical types, the antenna array is positioned by a motor. For electronic antennas, different combinations of fixed elements are selected to focus the beam.

Low and High Gain Satcom Antennas for Aircraft

Low-gain model has conformal antenna mounted on fuselage. Because of its simplicity it operates only on services with slow data rates (600 bits per second) such as air traffic control and airline operational messages. Such data may be a stream of characters (letters and numbers) displayed on a screen. Low in cost, the low gain system operates in the "Aero L" service.

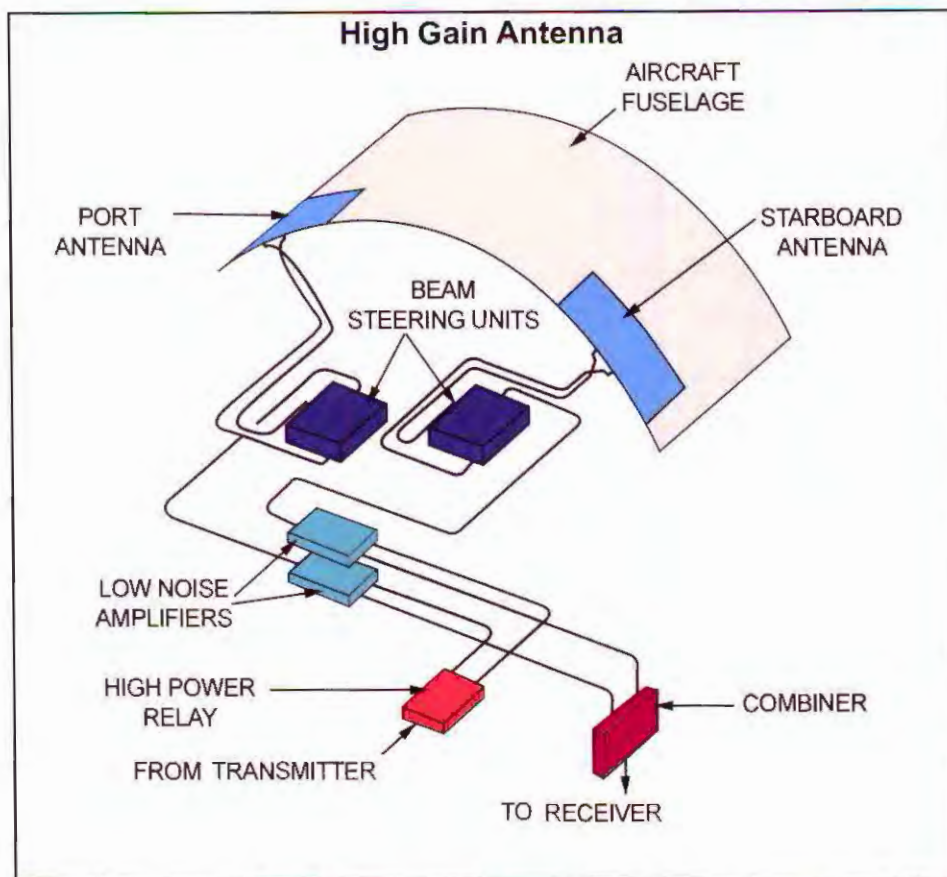
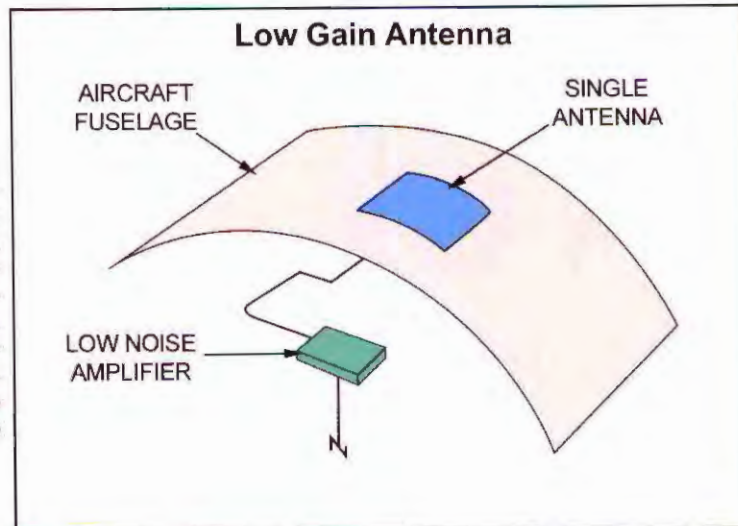

AlliedSignal

The high gain satcom antenna supports services with higher rates, such as "Swift 64," which handles multichannel voice, data, fax and Internet connectivity. The transmission rate is 64K bits per second.

High gain is achieved by an array of antenna elements formed into a beam that focuses on the satellite.

Although the satellite is stationary, the airplane is moving. The antenna, therefore, needs the "beam steering unit," which keeps the beam aimed at the satellite. Steering information is obtained from the airplane's navigation system.

Electronically Steered Conformal Antenna



High gain satcom antenna, the "Airlink" by Ball, measures 32-in x 16-in, with a depth of only .29-in. It is a conformal antenna, sufficiently flexible to curve to the aircraft body. It is attached by fasteners around the edges of the antenna. Frequency range is 1530-1559 MHz and 1626.5-1660.5 MHz, for communicating with Inmarsat satellites.

Antenna circuits inside the housing use microstrip technology, with no active electronic components. The outer assembly is fiberglass laminate.

Conformal antenna location for a B-747. Antenna is positioned so mounting holes along edges and two holes for the RF cables do not interfere with structure of the airplane.

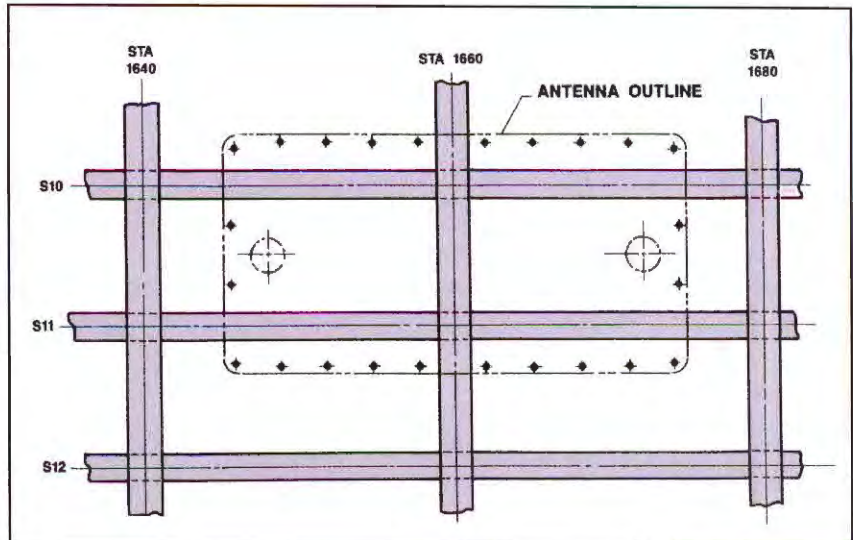

Electromechanically Steered Antenna

Two steerable satcom antennas mounted in a rudder cap. They operate electromechanically, under control of a beam steering unit. The antennas are aimed toward the satellite, regardless of aircraft position on earth, and provide high gain performance.



Honeywell/Thales

In-flight High Speed Data System

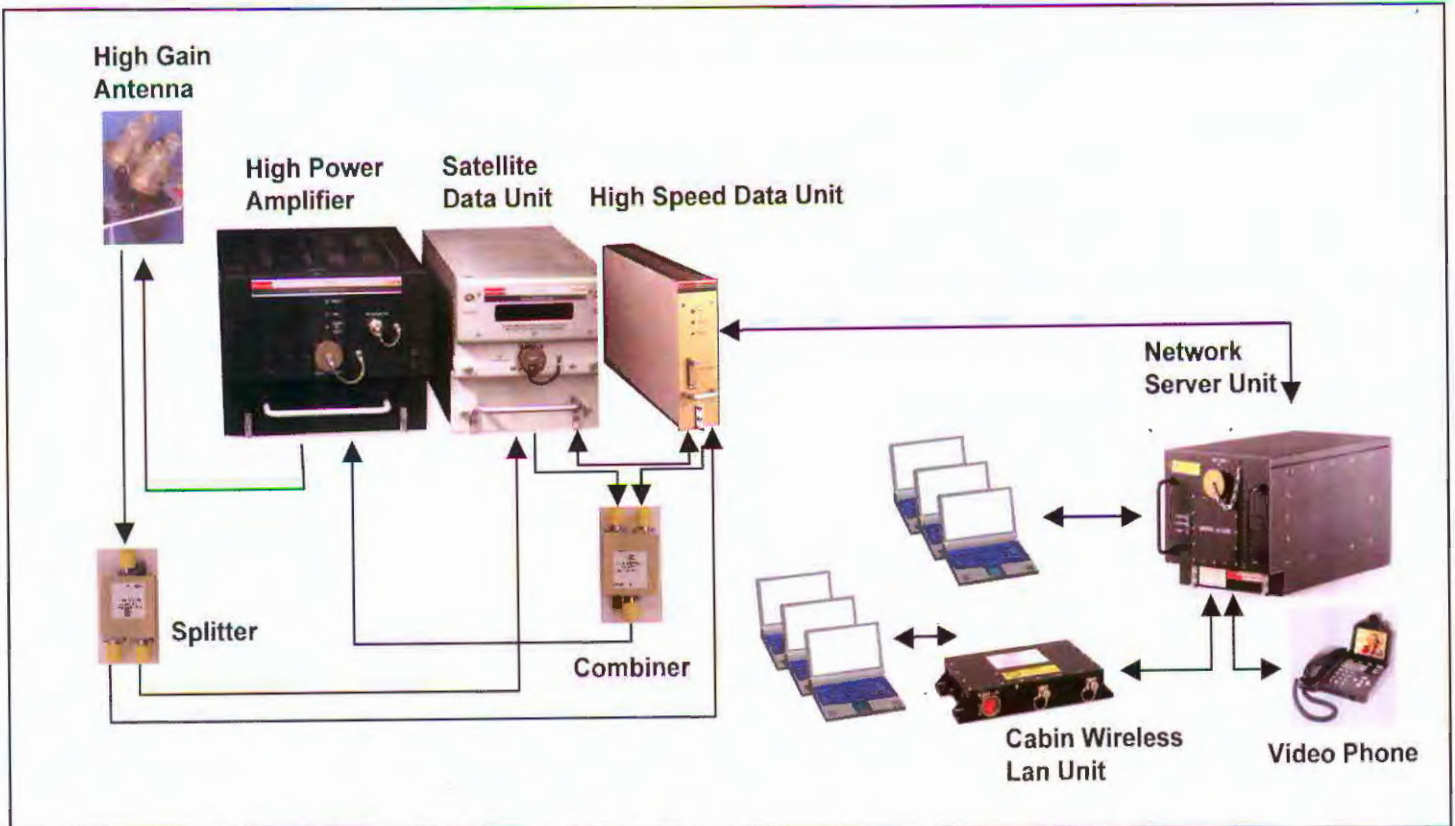

This system, developed for business jets by Honeywell and Thales, accesses private or corporate computer networks anywhere in the world from the passenger cabin. Using the Inmarsat Swift64 service, the passenger uses his own laptop to access the cabin network pictured above. The interface between cabin network and satcom avionics (at the left) is a High Speed Data Unit (top center). The Network Server Unit (top right) is a server

and provides file storage and other resources such as an ISDN/Ethernet router and hub switch. It complies with ARINC 763.

In addition to data services, the system provides voice, fax and live video teleconferencing.

Intermediate Gain Satcom Antenna



CMC Electronics

The "intermediate gain" antenna is a more recent satcom type. Operating in the Aero I service, it can operate with voice, fax and data. It is simpler and lower in cost than a high gain model because of stronger "spot beam" transmission from Inmarsat-3 satellites.



Honeywell

Voice is digitized and encrypted to keep communications secure. Quality exceeds that of passenger telephone systems based on network of ground stations.

Inmarsat Aero Services

Swift64

Based on Inmarsat's Global Area Network (GAN), Swift64 offers Mobile ISDN and IP-based Mobile Packet Data Service (MPDS) connectivity at a basic rate of 64 kbit/s to support high-quality voice, fax and data communications for air transport, corporate and VIP and government users.

Aero H

The original Inmarsat voice and data service, Aero H supports multichannel voice, fax and data communications at up to 9.6 kbit/s anywhere in the satellites' global (hemispherical) beams for air transport, corporate and VIP and government users.

Aero H+

An evolution of Aero H. When an Aero H+ equipped aircraft is operating within a high-power spotbeam from an Inmarsat I-3 satellite it can receive Aero H levels of service at lower cost. Outside the spotbeams the terminal works with the global beam as if it were a standard Aero H system.

Aero I

Exploiting the spotbeam power of the Inmarsat I-3 satellites, Aero I brings multi-channel voice, fax and data at up to 4.8 kbit/s to corporate aircraft, military transports and regional airliners through smaller, cheaper terminals.

Aero L

Low-speed (600 bit/s) real-time data, mainly for airline ATC, operational and administrative communications.

mini-M Aero

Single-channel voice, fax and 2.4kbit/s data for small corporate aircraft and general aviation.

Aero C

The aeronautical version of the Inmarsat C low-rate data system, Aero C allows non-safety-related text or data messages to be sent and received by general aviation and military aircraft operating almost anywhere in the world. Aero C operates on a store-and-forward basis; messages are transmitted packet-by-packet, reassembled and delivered in non-real-time.

Compact, lightweight Aero C equipment, with an antenna similar in size to a VHF blade, can be installed in corporate and general aviation aircraft and helicopters.

Aero C supports:

- Globally available two-way 600 bits/s data communications, messaging, polling and position-reporting for non-safety-related purposes
- Interfaces with international X.25 networks
- Integrated Global Positioning System (GPS) capability through a common antenna.

Aero C aircraft equipment comprises an antenna, a duplexer and a transceiver. The transceiver is connected to a flight deck data terminal or a laptop and, optionally, to a printer.

Capable of handling messages up to 32,000 characters long, Aero C is typically used for weather and flight plan updates, maintenance and fuel requests, in-flight position reporting, and business communications.

Aero C is based on store-and-forward technology. Messages entered into the aircraft terminal are subdivided into data packets and transmitted to the ground earth station, where they are reassembled into the complete message and sent to the ultimate addressee via the national and international telecommunications networks. The process is reversed for messages to the aircraft.

The packets are error-protected: if errors are detected, retransmission of the affected packages is requested. The complete messages are transmitted to destination only after all error-free packets have been recompiled.

Four Inmarsat satellites are in geostationary orbits, 22,500 miles above the earth. Spread around the globe, they all follow the line of the equator. Because one orbit equals one rotation of the earth, they appear fixed in position. Each satellite has one backup spare in orbit.

Early satellites produced "global" coverage, spreading their power over the greatest area. The present generation, Inmarsat-3, also broadcasts "spot beams," which concentrate power over a narrower area. In the illustration, the spot beam of each satellite is shown in blue.

Spot beams illuminate the busiest air traffic regions and simplify equipment on the aircraft.

Ground Station Location

United Kingdom	Norway
Singapore	Australia
France	Canada
USA (3)	Japan

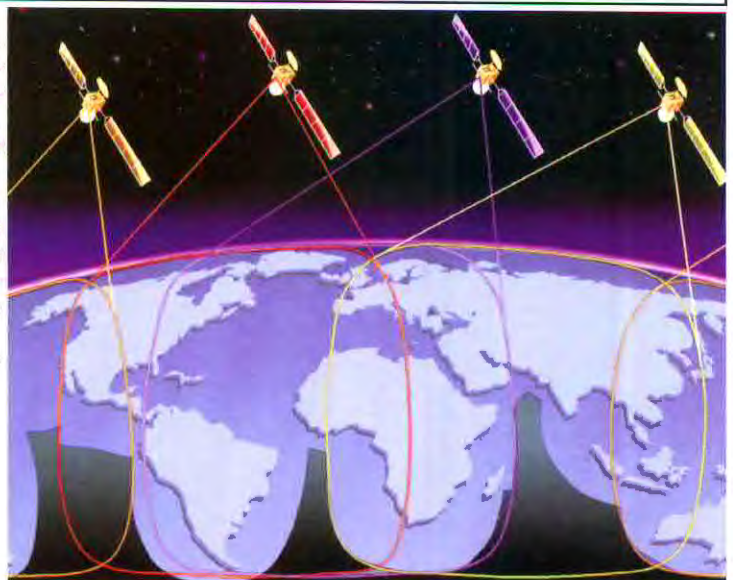

Honeywell-Thales

Review Questions

Chapter 5 Satcom

- 5.1 What are three advantages of satellite communications?
- 5.2 What is the name of the next generation air traffic control system based on satellites?
- 5.3 How many Inmarsat satellites provide global coverage, and where are they located?
- 5.4 Name two types of stations used in satellite communications.
- 5.5 Name one advantage and one disadvantage of a low gain satcom antenna.
- 5.6 What is an advantage and disadvantage of a high gain satcom antenna?
- 5.7 What is a “conformal” antenna?
- 5.8 What is the term “Space Segment”?
- 5.9 After satellite messages are received at a Ground Earth Station, how do they get to their final destination?
- 5.10 On what band does the aircraft send and receive satellite communications?
- 5.11 What is the purpose of a Beam Steering Unit?
- 5.12 What is the typical location on the airplane for an electromechanically steered antenna?
- 5.13 Why do communications satellites appear to remain fixed in one position?

Chapter 6

ACARS

Aircraft Communication Addressing and Reporting System

Most aircraft communications fall into two categories; ATC and AOC. The first, "Air Traffic Control," is about safely separating aircraft by providing route and altitude clearances, radar tracking, weather advisories and other subjects dealing with airplanes in the same airspace. ATC ground stations are nearly all government-owned and operated.

Airlines are also a business. Each company needs

tactical information about when its flights take off, when they arrive, whether maintenance will be needed, fuel remaining, diversions, crew hours and dozens of other items. Communications in this category are AOC, "Airline Operational Control." Pilots call it "company communications."

As airplanes grew more numerous, airspace became more congested and cruise speeds approached

ACARS in the Cockpit

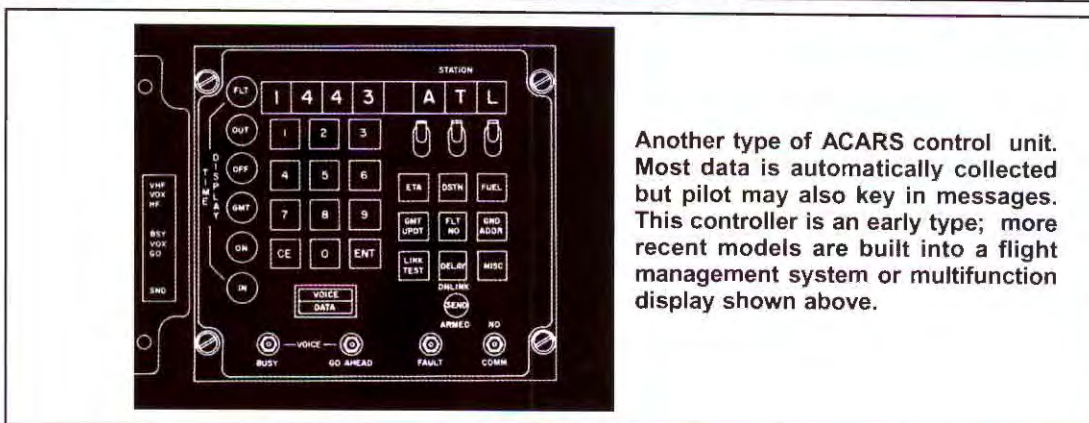
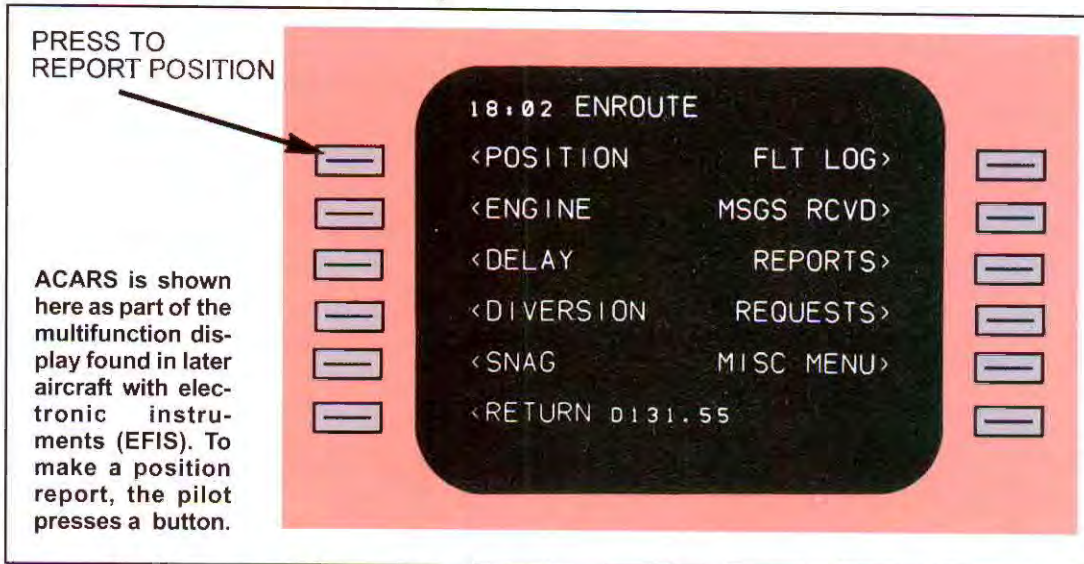

Mach 1, it was clear that a pilot communicating with both ATC and his company raised the workload to intolerable levels. In 1978, a system called ACARS was introduced to automate most company messages. Ground and satellite networks that support ACARS are operated by organizations such as ARINC in North America and SITA in Europe.

Meaning "Aircraft Communication Addressing and Reporting System," ACARS is used by airlines of all sizes, corporate aircraft and government agencies. Be-

cause it operates on digital messages, it is one of the earliest forms of "datalink" in commercial aviation. Not only does it eliminate voice for routine messages, but sends data automatically from sensors aboard the aircraft without assistance from the pilot.

OOOI. ACARS' first job was automatically communicating to the airline company the time each flight pushes back from the gate, takes off, lands and when it arrives at the destination gate. Put those functions together---Out, Off, On, In---and they form the abbrev-

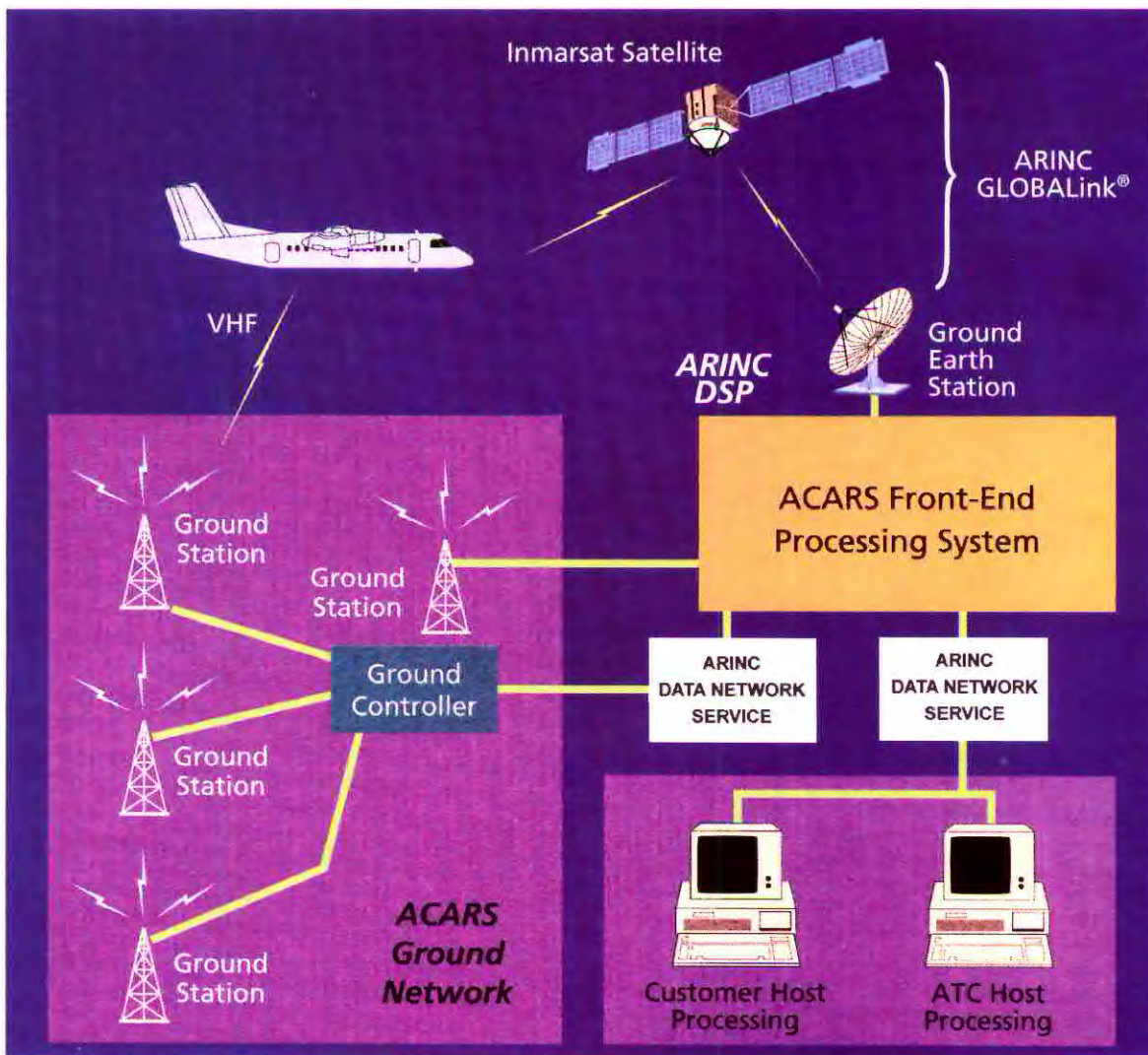





ACARS began with a network of ground stations (lower left) that communicate by VHF radio to aircraft mainly in North America. Full coverage is at altitudes above 20,000 feet, with additional stations at about 300 airports for on-the-ground communications.

More recently, ARINC extended ACARS worldwide by a satellite-based system known as "GLOBALink" (upper right). This service requires satcom equipment aboard the aircraft.

ARINC

ACARS Messages

"OUT" 	"OFF" 		"ON" 	"IN" 
Preflight and Taxi	Takeoff and Departure	En Route	Approach and Landing	Post-Landing and Taxi
From Aircraft Crew Information Fuel Verification Delay Reports OOOI Out	From Aircraft OOOI Off Destination ETA Fuel Remaining Special Requests	From Aircraft Position Reports ETA Updates Voice Request Engine Parameters Maintenance Reports Provisioning	From Aircraft ETA Changes OOOI On	From Aircraft OOOI In Gate Coordination Final Maintenance Status Fuel Verification
To Aircraft PDC Aero C ATIS Weight and Balance Runway Analysis Flight Plan Dispatch Release Remote Maintenance Release		To Aircraft ATIS ATC Oceanic Clearance Weather Ground Voice Request (SELCAL) Gate Assignment	To Aircraft Hazard Reports Weather Advisories	

Many different messages are transmitted by ACARS datalink. The service is used by airline and corporate aircraft in much of the world. Although most traffic is for airline company operations, ACARS also handles air traffic clearances when government radio services are not available, such as oceanic regions.

ACARS Message Format

PREAMBLE	TEXT	BLOCK CHECK
<p>The preamble contains the address of the aircraft (flight or tail number). If address is intended for another airplane, the message is rejected.</p> <p>The preamble also synchronizes the characters transmitted.</p> <p>There is an "acknowledgment" character to indicate the message is being received.</p> <p>A label identifies the message and how it will be routed. There are labels departure, fuel, ETA, diversion and about two dozen others.</p>	<p>Up to 220 characters can be transmitted in this block. They contain report information (departure time, arrival, etc.) which need only a few characters. However, more characters are included for "free talk," sending and receiving longer messages.</p>	<p>This sequence detects errors. If the system is operating properly, it generates characters for "ACK" (acknowledge) or "NAK" (negative acknowledge)</p>

Three building blocks of an ACARS message. Characters that make up the message are comprised of digital bits (ones and zeroes). They are, however, not transmitted digitally, but in analog form as two audio tones; 1200 and 2400 Hz. Transmission is through the aircraft VHF transceiver; downlinked or uplinked from an ACARS ground station.

At the receiving end, tones are decoded back into a digital signal.

This system will remain in operation until it is eventually replaced by all-digital ACARS signals and transmission through satellites.

ACARS Message on Aircraft Take-Off

N1234	QB	1	2804	RAL 5322
ADDRESS (Tail number of airplane)	MESSAGE LABEL "QB" means "Off Time"	DOWNLINK BLOCK IDENTIFIER	MESSAGE SEQUENCE (Minutes and seconds past the hour)	AIRLINE & FLIGHT NO.

aviation OOOI (pronounced "Ooee"). About eight million such messages are sent every month via ACARS.

A pilot does not have to receive the large volume of ACARS messages transmitted to other aircraft. If a message is not intended for the airplane it is not selected. Each ACARS system aboard the aircraft accepts only its unique address.

A message that requires several minutes to send by human voice moves through ACARS in milliseconds. A position report, for example, is done with the push of a button; the data is picked up from the airplane's navigation sensor. Other messages may be keyed in by the pilot.

Not only does ACARS reduce congestion in crowded com bands, but avoids the garble and error when two airplanes transmit on the same frequency at the same time. ACARS avoids collisions with other transmissions and checks each message for accuracy.

Another benefit is that pilots can flight-plan in a dispatch office but don't have to wait for clearances to come back from air traffic control. The information is sent to the cockpit via ACARS.

ACARS is expanding to other services. It reports engine performance to the ground while in flight, so problems are recognized early, often before they've caused major damage. By using the data to show normal performance, airlines obtain extended warranties from engine manufacturers. Weather information uplinked to the cockpit via ACARS can be evaluated while pilots are not in a high workload phase of flight. Over 60 applications, shown in the chart, are supported in the ACARS system.

SITA

There are two major organizations providing air-ground company communications for the air transport industry. One is ARINC, which mainly serves aircraft flying over North America. Similar services for Europe are provided by SITA (Société Internationale de Télécommunications Aéronautiques). On the VHF bands, the SITA service is called AIRCOM, which operates through ground stations. Increasingly, ARINC and SITA provide a full range of services via satellite, rather than a network of ground stations on VHF and HF bands.

Text of an Actual ACARS Message

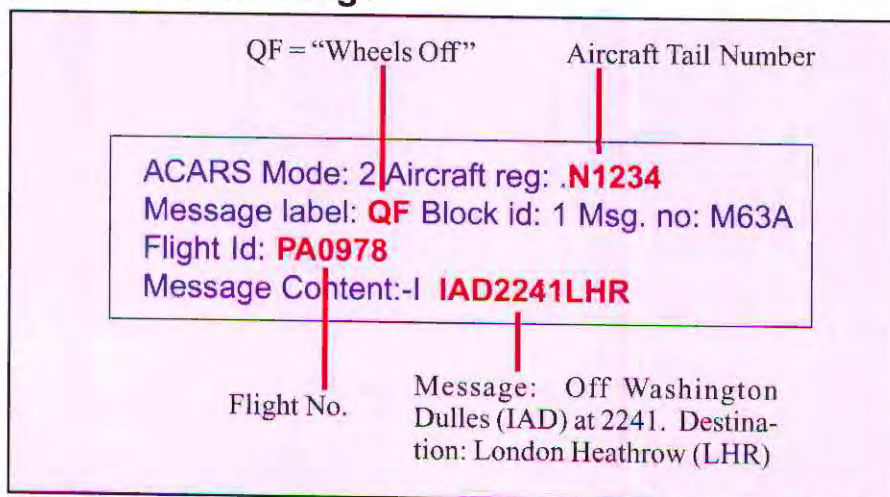

ACARS Bands and Frequencies

VHF (Very High Frequency)

REGION	VHF CHANNELS
USA, Canada	129.125, 130.025, 130.450 MHz
USA, Canada, Australia	131.550 MHz (Primary)
USA	131.125 MHz
Japan	131.450 MHz (Primary)
Air Canada	131.475 MHz
Europe	131.525, 136.900 MHz
Europe	131.725 (Primary)

These channels, at the upper end of the VHF band, carry ACARS messages to and from ground stations. Channels shown in red are original ACARS frequencies, which have expanded with increasing air traffic.

New forms of transmission are multiplying the number of messages that can be carried on a single channel. Known as VDL---VHF datalink---it enables one channel to carry up to 30 times more data than the conventional ACARS.

HF (High Frequency)

GROUND STATION	HF CHANNELS
Shannon, Ireland	8843, 11384
Hot Yai, Thailand	5655, 13309
Islip, New York	2887, 5500, 8846, 17946
Kahalelani, Hawaii	2878, 4654, 6538, 21928
Johannesburg, S.Africa	8834, 13321, 21949

A sampling of frequencies and stations in the High Frequency band used during long-range flights over oceans and remote areas. Each ground station has channels throughout the band in order to select one according to changing radio propagation conditions.

Review Questions

Chapter 6 ACARS

- 6.1 What is the meaning of the abbreviation "ACARS"?
- 6.2 What type of communications occur on ACARS?
- 6.3 Who operates ground and satellite services for ACARS?
- 6.4 What is the meaning of the ACARS message, "OOOI"?
- 6.5 How is an ACARS message received only by the aircraft it's intended for?
- 6.6 What two bands carry ACARS services?
- 6.7 What satellite-based system carries ACARS services worldwide?

Chapter 7

Selcal

Selective Calling

During oceanic flights, aircraft monitor a HF (high frequency) radio for clearances from a ground controller. Because HF reception is often noisy, and many messages are intended for other airplanes, a pilot prefers to turn down the audio. He will not miss calls intended for him, however, because of Selcal---selective calling. The ground controller sends a special code that sounds a chime or illuminates a light to warn the pilot of an incoming message and to turn the volume up. Because it's selective, Selcal "awakens" only the HF receiver with the appropriate code.



This Selcal controller, located on the instrument panel, monitors two radios simultaneously (VHF or HF). An incoming tone code lights a green lamp and sounds an aural warning (chime). The pilot turns up the audio volume on the radio. Pressing the RESET button arms the system to receive the next call.

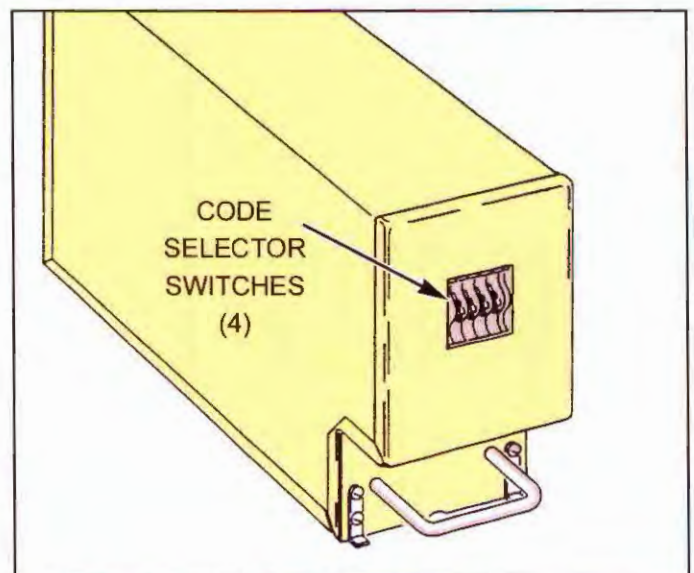

Selcal decoder is an LRU (line replaceable unit) located remotely in the airplane's electronic bay. The four-letter code assigned to that airplane is programmed manually by four thumb wheels (code selector switches).

The four-letter code (EG-KL, for example) is drawn from the letters A through S (I, N and O are excluded).

Some aircraft have two decoders, one to receive Selcal tones for up to four radios (2 VHF and 2 HF). The same assigned letters, however, are entered into the decoders.

How Selcal Code is Generated

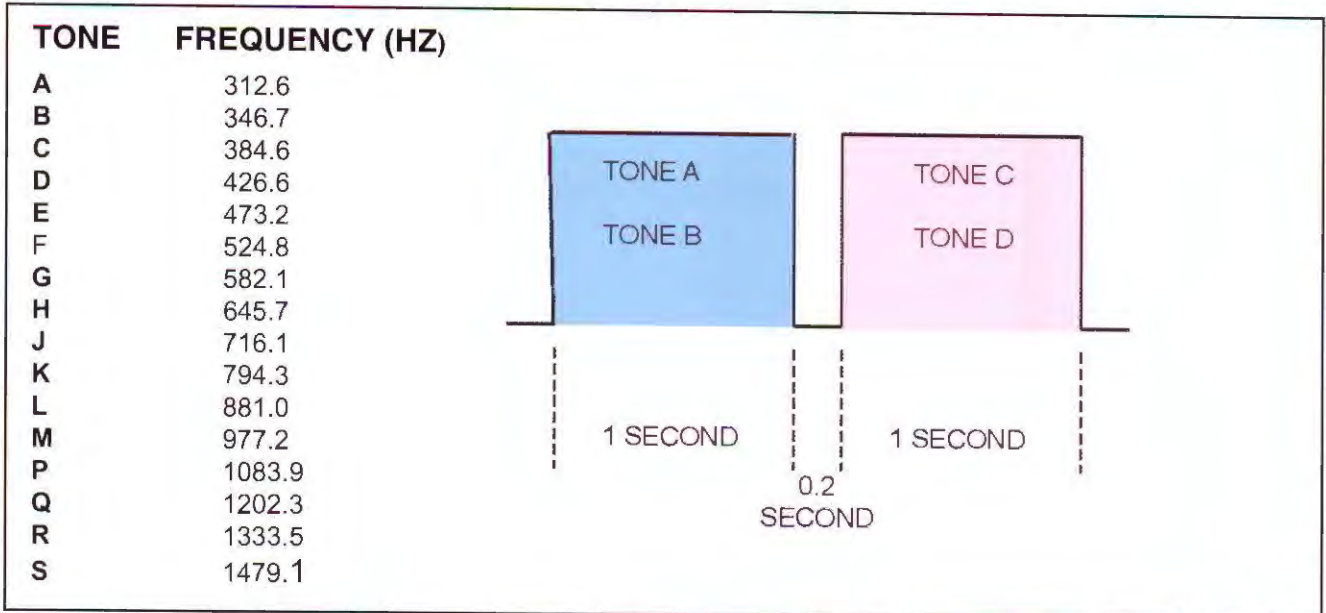

A Selcal code consists of four tones taken from the 16 audio frequencies shown at the left. In this example, the code is AB-CD. As seen in the diagram, they are sent in two pairs. A and B are mixed together (312.6 and 346.7 Hz) and transmitted for one second. After a .2-second

interval the second pair is sent; C and D, or 384.6 and 426.6 Hz. (The technique is similar to touch-tone dialing for telephones.) Because the tone signals are audio in the voice range, they can be detected by a conventional VHF or HF communications transceiver.

Selcal Ground Network

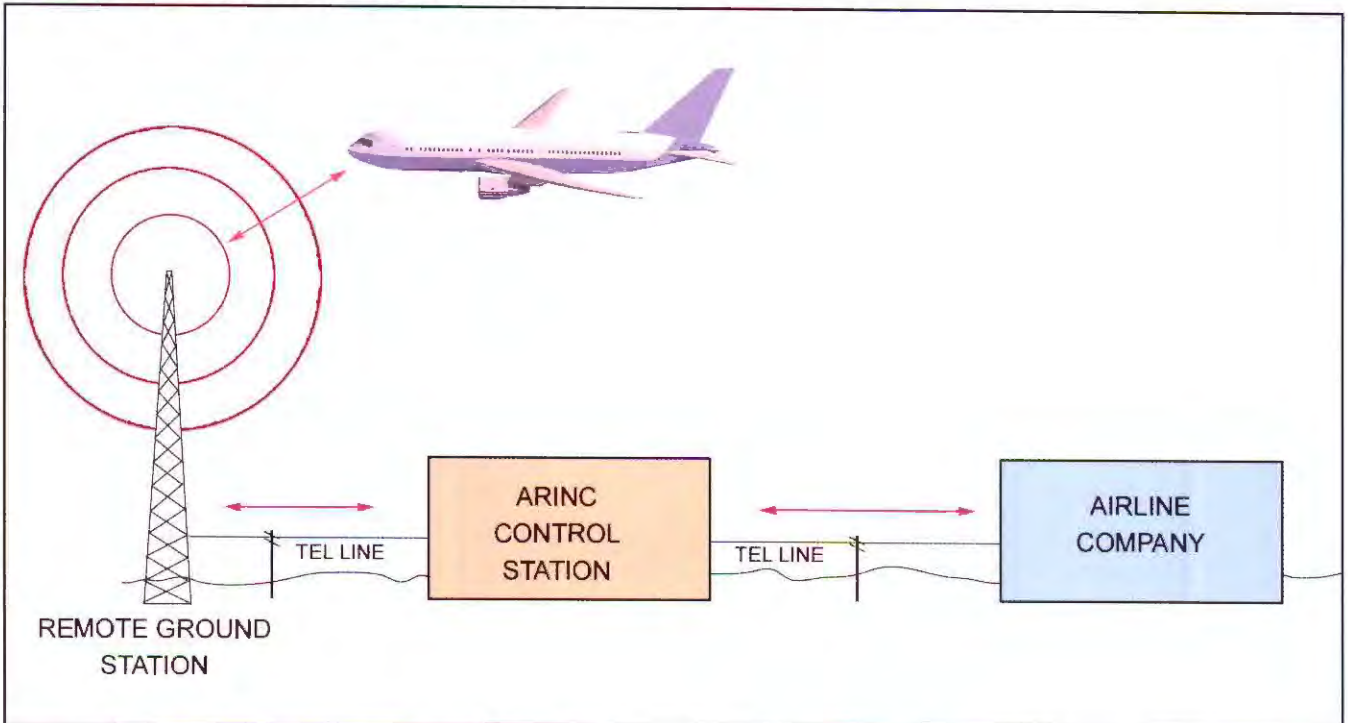

When Selcal must operate on VHF, where maximum range is about 200 miles, it is done through a network of remote ground stations. The airplane, always within range of some ground station, transmits and receives Selcal messages through an ARINC control station (in the U.S.). ARINC relays the message to the airline com-

pany. The link between stations is usually through telephone lines.

Selcal over oceanic routes is done on HF, where range from airplane to ground may be several thousand miles. The future of Selcal will be satcom; the airplane will communicate with satellites for relay to the ground.

VHF. Selcal also operates with VHF radios, used by aircraft flying within a country or continent. Not only does Selcal reduce pilot workload, but extends the communication distance of VHF. If an airline company in Denver, for example, wants to talk to one of its airplanes in flight over Chicago, this is far beyond the range of VHF. Instead, the message is sent through a telephone line to a network of ground stations. A VHF ground station near the aircraft transmits to the airplane, and the pilot is signalled. He replies on VHF to the ground station and the message reaches the airline company through the network.

Coding. Selcal is based audio tones, as shown in the illustration. Each airplane has a code of four letters set into the Selcal decoding unit aboard the airplane.

The code is entered into the flight plan so controllers can address it.

Although there are nearly 10,000 possible four-letter codes, they are in short supply. The demand is so high that more than one aircraft may be assigned the *same* Selcal code. To avoid answering a call intended for another airplane, identical codes are assigned in widely separated parts of the world. There is also an attempt to assign the same code to airplanes with different HF channel assignments.

It is important to warn pilots that it's possible to receive a Selcal alert not intended for them. This can be corrected by the pilot by clearly identifying his flight to the ground station.

Selcal Airborne System

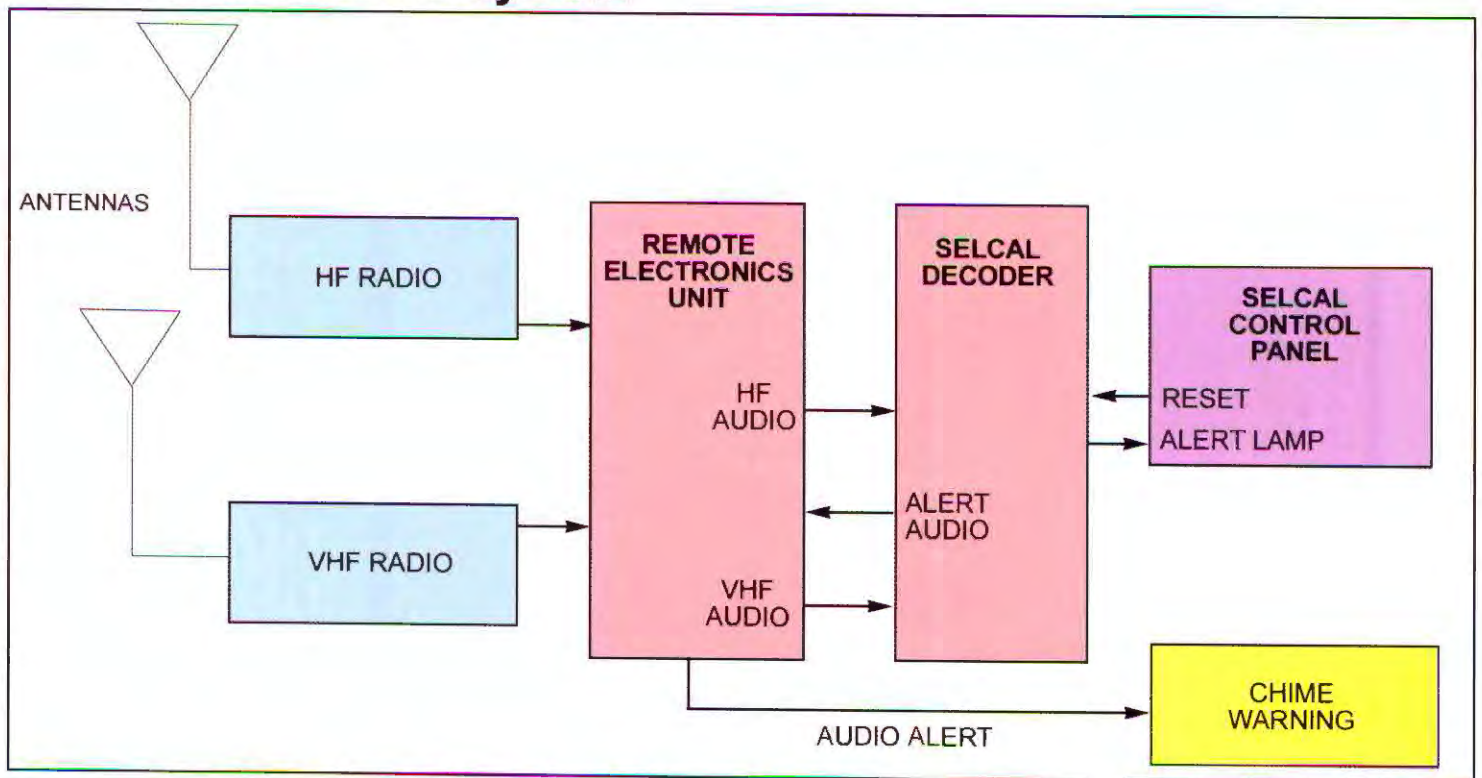

Block diagram of Selcal system. Signals are received from ground stations through the aircraft HF and VHF transceiver. They are processed by the Remote Electronics Unit and sent to the Selcal decoder for delivery to the pilot (on a screen or printer).

An incoming signal with the correct code illuminates a green panel light in the Selcal Control Panel and sounds a chime (aural alert).

A single system is shown here, but many aircraft have dual Selcal installations.

Review Questions

Chapter 7 Selcal

- | | |
|---|---|
| 7.1 What does the contraction “Selcal” mean? | 7.6 What precaution is necessary if a pilot receives a Selcal intended for a different airplane? |
| 7.2 Give two reasons why Selcal is used. | 7.7 How is the problem reduced where two aircraft have the same Selcal code? |
| 7.3 How many tones are in a Selcal code? | 7.8 How is the pilot warned of an incoming Selcal message? |
| 7.4 How many Selcal tone pairs are transmitted simultaneously? | |
| 7.5 Can two aircraft have the same Selcal code? | |

Chapter 8

ELT

Emergency Locator Transmitter

Two U.S. Congressmen were missing in an Alaskan snowstorm in 1972 and never heard from again. Search and rescue forces flew over 3000 hours looking for the downed airplane but found nothing. Even if the congressmen survived the crash and called for help there was no assurance that anyone was listening or within radio range.

Congress responded with a law requiring aircraft to carry a “beacon” to automatically sense a crash and send out emergency signals on 121.5 MHz, the distress frequency. The theory was that other airplanes flying

in the vicinity would monitor 121.5 (found on all VHF com radios) and report a beacon signal to a ground station. The new law required General Aviation airplanes (Part 91) to be equipped with an ELT. For the airlines (Part 121) ELT’s were required for extended flight over water and uninhabited areas.

Flaws in the system soon appeared. First, there was no guarantee a distress call would be heard by a passing airplane or ground facility. What is more, the number of false alarms rose so high that only a few percent resulted from actual crashes. Despite an enor-

A beacon, like this Artex C-406-N, sends three separate ELT signals to the antenna through one coaxial cable; a warbling tone on 121.5 and 243 MHz, and an encoded digital message on 406 MHz. Output power on 406 is 5 watts, with a lithium battery rated for 5 years.

Note the precaution about mounting the ELT with respect to the direction of flight, which assures proper operation of the crash sensor (a G-switch).

An ELT for a helicopter has a different G-switch, which responds in six different directions.



ARTEX

mous waste of search and rescue resources, there was agreement that the system should not be abandoned, but improved.

Changes came in the form of tighter standards and better design. The ELT industry also gained experience and learned that failure to activate during a crash was often due to poor ELT installation, corroded internal parts, defective G-switches, faulty antennas and cables and dead batteries.

In 1995 all ELT's under the original certification (TSO C91) would be replaced by the next-generation ELT (TSO 91a). The regulations also tightened maintenance requirements; once a year, an ELT must be inspected for proper installation, battery corrosion, operation of controls and crash sensor, and sufficient signal radiated from the antenna.

Cospas-Sarsat

While the new rules improved ELT hardware, there was still the question; "Who's listening for distress signals?" The answer arrived with earth-circling satellites. By listening from orbit, satellites increase the chance of intercepting an ELT distress signal.

The satellite system, known as Cospas-Sarsat, consists of satellites provided by the United States and Russia. "Cospas" is a Russian term meaning "Space System for Search of Vessels in Distress." These satellites are primarily for the Russian navigation system, but with added instruments for search and rescue. They operate on 121.5 MHz, the civil aviation distress frequency, and 243 MHz, the military equivalent.

U.S. satellites are "Sarsat," for "Search and Rescue Satellite Aided Tracking." The primary role is weather survey, with search and rescue instruments added on. As shown in the illustration, the satellites are supported by a network of ground stations, mission control and rescue coordination centers.

Location. In the era before satellites, rescuers found downed aircraft by radio-direction finding. Using an attachment to a VHF radio and a directional antenna, searchers "home in" on the ELT signal.

Satellites use a different technology, the "Doppler shift." As a satellite rises over the horizon toward the crash site, its forward speed "squeezes" the ELT radio waves. Instead of receiving 121.5 MHz, the satellite hears a slightly higher frequency. When the satellite moves away from the crash site, 121.5 appears to stretch out--producing a lower frequency. These changes (Doppler shift) reveal the position of the crash after several satellite passes from different directions. Although Cospas-Sarsat solved the monitoring problem, it actually *increased* the number of false alarms by its global coverage.

Search and Rescue Satellites

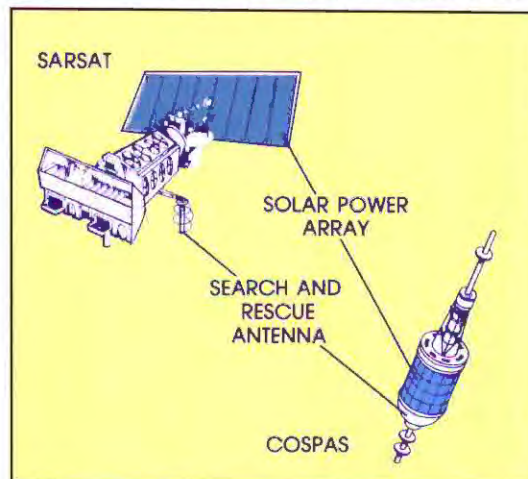

The U.S. satellite, SARSAT, is operated by NOAA (National Oceanic and Atmospheric Administration). It is in polar orbit at an altitude of 528 miles, circling the earth once every 102 minutes.

The Russian satellite, COSPAS, circles the earth every 105 minutes at an altitude of 621 miles.

The US satellites' primary mission is observing weather and the environment, and is also equipped for receiving search and rescue signals.

COSPAS is part of the Russian spacecraft navigation system, with the search and rescue function added.

Payloads on both satellites (for search and rescue) are provided by France and Canada.

Ground Stations

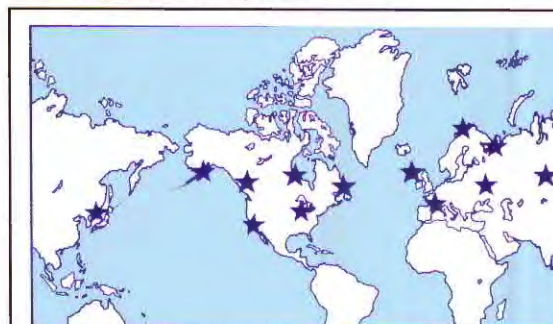

There are ground stations over the world for the search and rescue system. Known as "Local User Terminals," they receive emergency transmissions picked up by satellites from downed aircraft. Almost half the world is covered for ELT's operating on 121.5 MHz; the entire globe is covered on the 406 MHz frequency.

406 MHz ELT

By the year 2000, more than 180 countries voted to end the 121.5/243 MHz generation of emergency beacons. The cut-off date would be 2009. The replace-

ELT Components

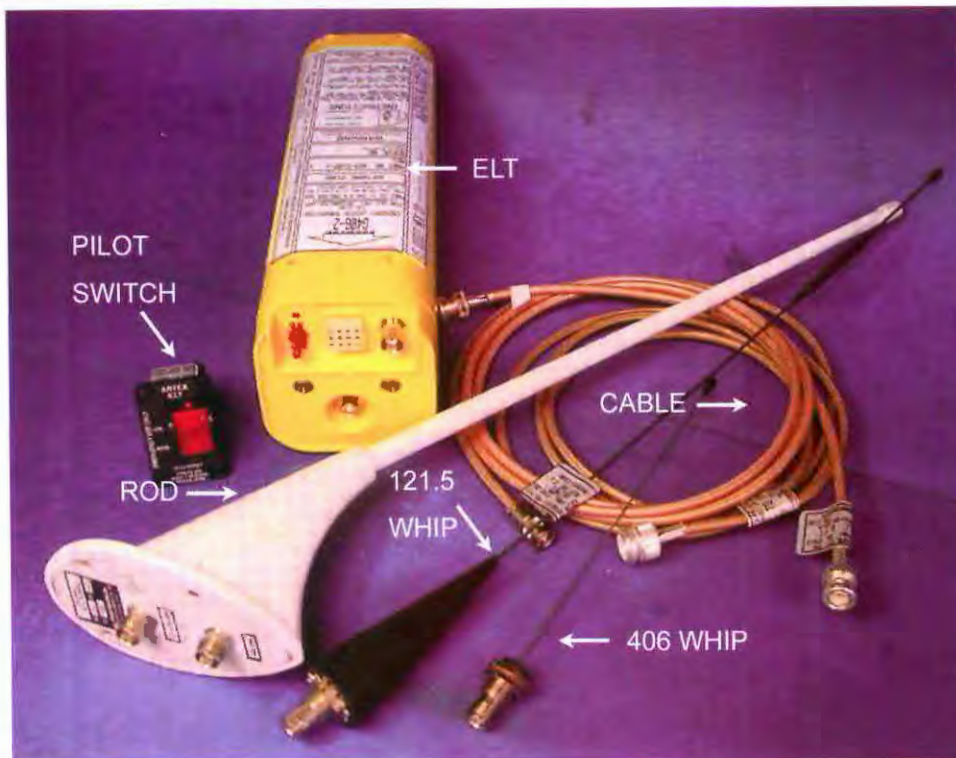

Major components of an ELT. The system broadcasts on three emergency frequencies; 121.5 MHz, the original distress channel; 243 MHz, the military distress frequency and the newer 406 MHz. When a crash activates a G-switch inside the ELT a varying audio tone is broadcast (up to 50 hours) on 121.5 and 243.

The antennas are chosen according to speed of the aircraft; the rod is for greater than 350 kt, the whip for slower aircraft.

Although the ELT activates automatically, it can also be turned on manually by the pilot switch. If the ELT is activated accidentally on the ground, it sounds a buzzer to alert the ground crew.

For the ultimate in accuracy, the ELT can broadcast latitude and longitude (on 406) if this data is provided from the airplane's navigation system.

(Shown is the Artex G406-2.)

ment is 406 MHz, with numerous improvements to reduce false alarms and raise location accuracy. (406 is operating now and can handle 121.5 and 243 MHz).

The 406 system is a mixture of Leosar and Geosar satellites. Leosar ("low earth orbit search and rescue") completely covers the globe and can "store and forward" messages. The satellite does not have to see both crash site and ground station at the same time, but stores the distress message, then replays it when a ground station comes into view.

Leosars, however, do not provide continuous coverage; an airplane in distress must wait for the satellite to come into view. This gap filled by additional satellites known as Geosars ("geosynchronous orbit search and rescue"). Parked 22,500 miles above the equator in geosynchronous orbit, they appear stationary and provide full earth coverage, except over

North and South poles.

Because Geosars are stationary, they cannot find beacons by the Doppler shift. They must receive a distress message that contains the airplane's position. This information is provided by a GPS receiver that is part of the ELT or from an external GPS receiver on the airplane.

The 406 system is far more capable than the first-generation ELT, which guided rescuers only within about 15 miles of the crash site. They had to narrow the search with a homing receiver. The 406 brings rescuers within 1 to 3 miles of the target using improved Doppler shift detection. The most precise guidance is when the 406 MHz ELT is coupled with a GPS, where accuracy becomes 300 feet or less.

The transmitting power of a 406 ELT is 5 watts,

versus one-tenth watt for 121.5.

When an airplane crashes, the occupants' chance of survival rapidly drops with the passage of time. Nevertheless, search and rescue forces do not respond to the first alert from a 121.5 ELT. Because so few signals are from actual crashes, rescuers face unnecessary hazards. They don't start the search until the alarm is verified. With the 406 system, however, they will respond to the first alert, which saves an average of six hours in reaching a crash site.

Registration. Much of the benefit from 406 is from an ELT registration system. No longer will an ELT broadcast anonymously, but transmits its identification as a digital message on the radio signal. Each

user of a 406 ELT must register (at no charge) with Sarsat authorities, giving telephone numbers and other contact information. Each 406 ELT is issued a serial number that is broadcast with the signal.

Now when a distress call is received by search and rescue, they make a telephone search. The pilot may be at home or work (unaware the ELT had a false activation). Searchers speak with an airport manager who checks the ramp for the airplane, or make additional phone calls to verify whether the airplane actually made the trip and is in distress. The registration program should reduce false alarms by 70 percent.

406 MHz ELT System

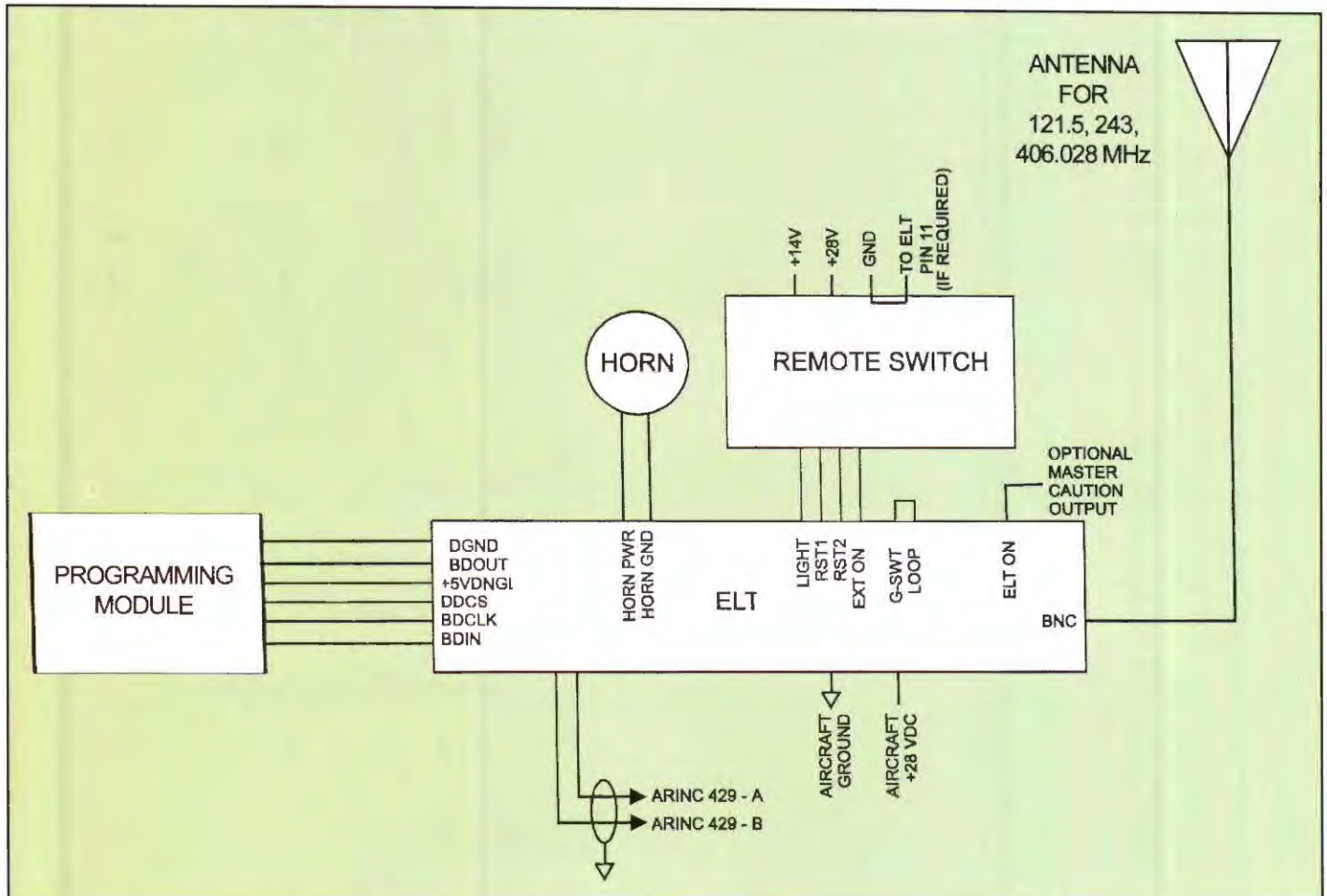

The Programming Module (lower left) sets up the 406 ELT for its unique code; a 24-bit address or aircraft tail number. This is required of all 406 ELT's. At top center, the Horn sounds to warn the pilot of a false activation. The Remote switch controls the ELT from the cockpit. At the bottom center, the ARINC 429 connections bring a

signal from the airplane navigation system into the ELT. This transmits an accurate location of the downed aircraft.

At upper right, the single antenna radiates three ELT frequencies through one cable; 121.5, 243 and 406 MHz.

Artex

ELT for Fleet Operation

DONGLE AND TOP COVER

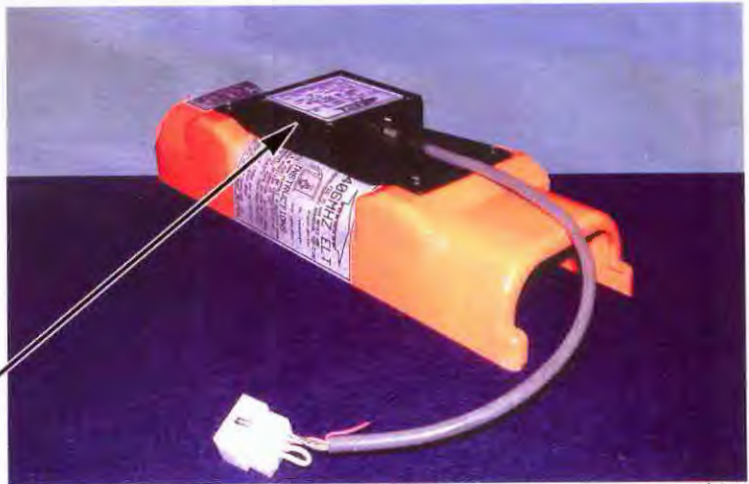

Artex

The 406 ELT is normally installed aboard one airplane and programmed with a unique address. Fleet operators, on the other hand, want to move an ELT among their various aircraft. This is possible with a model like the Artex model shown here. Attached to the top cover is a "dongle," a hardware key that automatically programs the ELT for that aircraft. The dongle and top cover always remain with the aircraft and the ELT is removed when needed elsewhere. Whenever an ELT is returned the airplane, the dongle reprograms it with the correct identification (a 24-bit code).

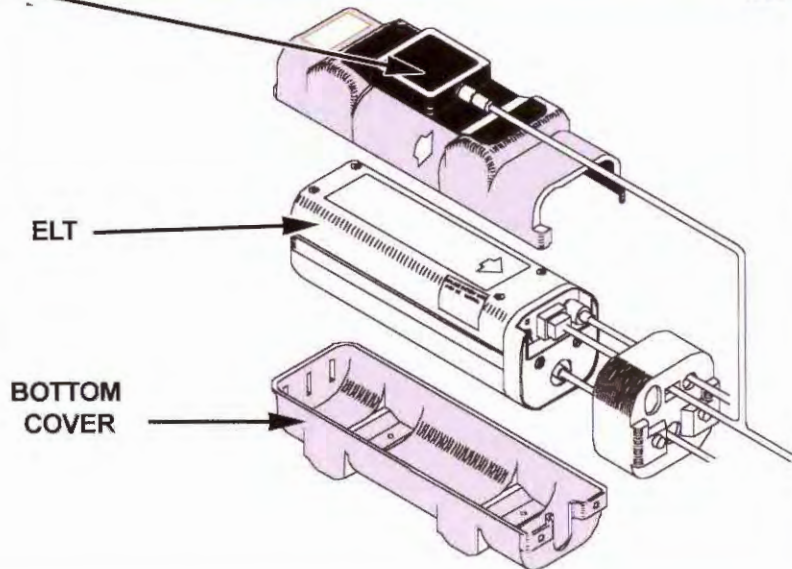

Artex

"TRANSMITTER ACTIVE" ANNUNCIATOR LIGHT

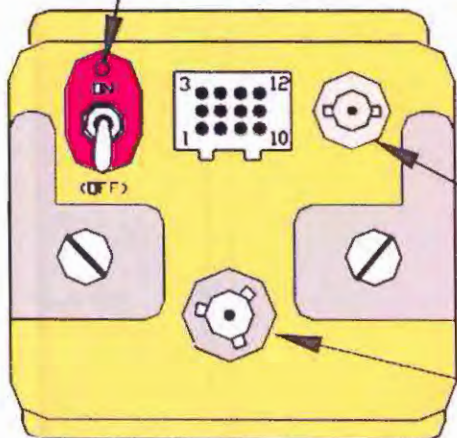

ELT controls and connections

121.5 MHz OUTPUT BNC CONNECTOR

406.025 MHz OUTPUT TPS CONNECTOR

Cospas-Sarsat System

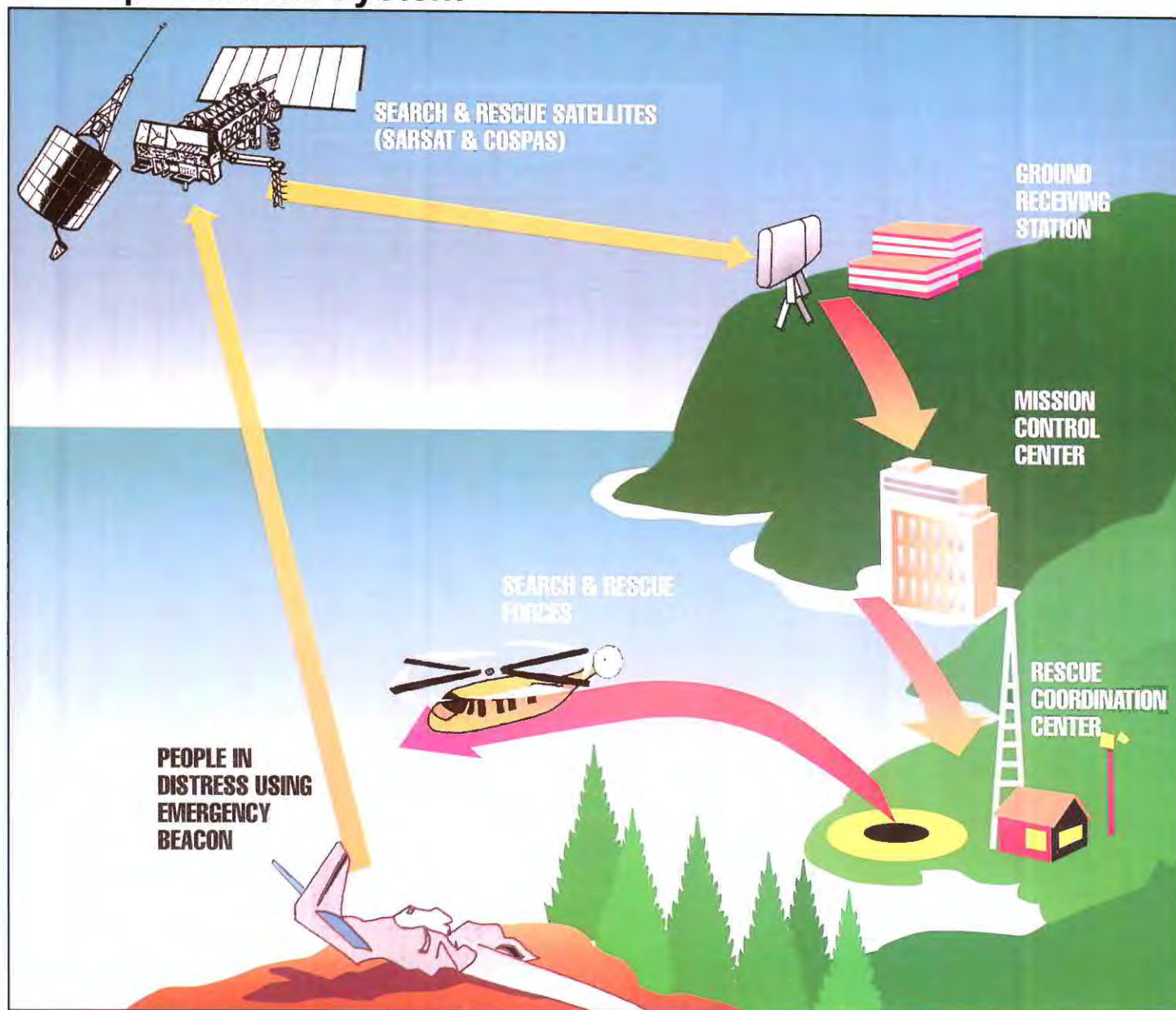

There are two types of satellites in the COSPAS-SARSAT system (see upper left). One is LEO, for low earth orbit. The other is GEO, for geostationary earth orbit. Because LEO's circle over North and South poles, they provide coverage in these regions. LEO's also are better able to pick up signals when the distress aircraft is surrounded by trees and other obstructions. This is be-

cause the LEO moves rapidly across the sky and views the distress aircraft from many different angles.

GEO's, on the other hand, are stationary over the equator to cover large areas of the earth. The advantage is that a GEO picks up a distress call almost immediately. Thus, the two types---LEO and GEO work well together.



406 ELT Registration

Unlike first-generation ELT's, it is important to register a new 406 MHz ELT. This data is used by authorities to identify aircraft type, ownership, telephone number, home base and other information. It enables searchers to discover most false alarms before taking off on a dangerous and costly rescue mission.

Review Questions

Chapter 8 ELT (Emergency Locator Transmitter)

8.1 What three radio frequencies are sent out by an ELT during a distress call?

8.2 Why must an ELT be mounted in line with the direction of flight?

8.3 Name the satellites that pick up and relay ELT signals?

8.4 Name one method satellites use to locate a downed aircraft transmitting an ELT signal.

8.5 Where do satellites relay the location of downed aircraft?

8.6 What is the most accurate method for identifying the location of an ELT signal, as used in the 406 MHz system?

8.7 What is the main benefit of registering ELT's, giving aircraft ID, and ownership?

8.8 How accurately can searchers locate a 406 MHz ELT coupled to a GPS source?

Chapter 9

VOR VHF Omnidirectional Range

Navigating by radio signals is one of the most successful and reliable aviation systems ever developed. Every day many of the 2,000 flights in the U.S. alone fly through clouds, darkness, rain and fog---reaching their destination in greater safety than driving an automobile. When an accident happens, investigators almost never find that a faulty navigational aid misled a pilot into a hazardous situation.

Not long ago, radionavigation began its greatest change in 75 years. "Nav aids," as they're called, consist of thousands of ground stations emitting guidance signals for at least eight avionics navigation systems. In a transition now in progress, ground stations will be replaced by signals from space, broadcast by orbiting satellites. The changeover will occur over the next 20-30 years, with both ground-based and satellite navigation existing side by side. The world made a decision through the International Civil Aviation Organization that future air navigation will be "GNSS"---for Global Navigation Satellite System. To keep air travel safe during the changeover, early ground stations must remain operational over the long transitional period. Those years will also enable aircraft operators to get full value out of their large investment in today's avionics systems.

VOR and DME Radiate from Same Station

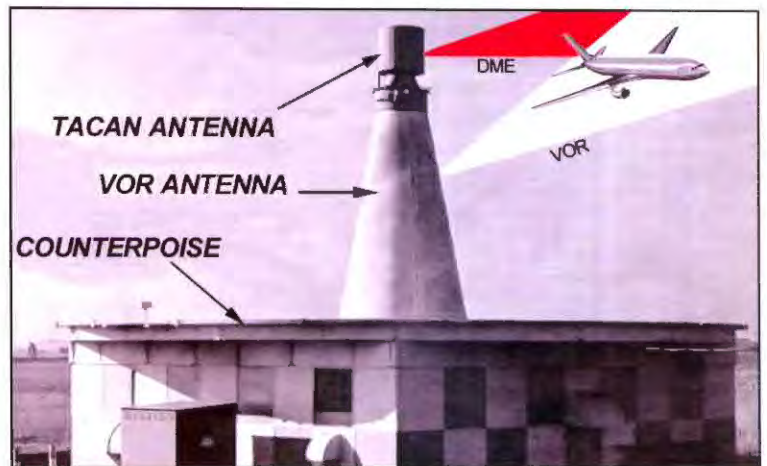

Vortac (VOR + Tacan) ground station. The VOR antenna atop the shelter transmits the VOR signal. The Tacan antenna is a military navigation system which transmits the DME signal (distance measuring equipment). Tacan means "Tactical Air Navigation." Only military aircraft use the azimuth (directional information) from the Tacan station.

The "counterpoise" at the base is a grid of metal that acts as an electrical ground to improve efficiency of the signals.

VOR Coverage

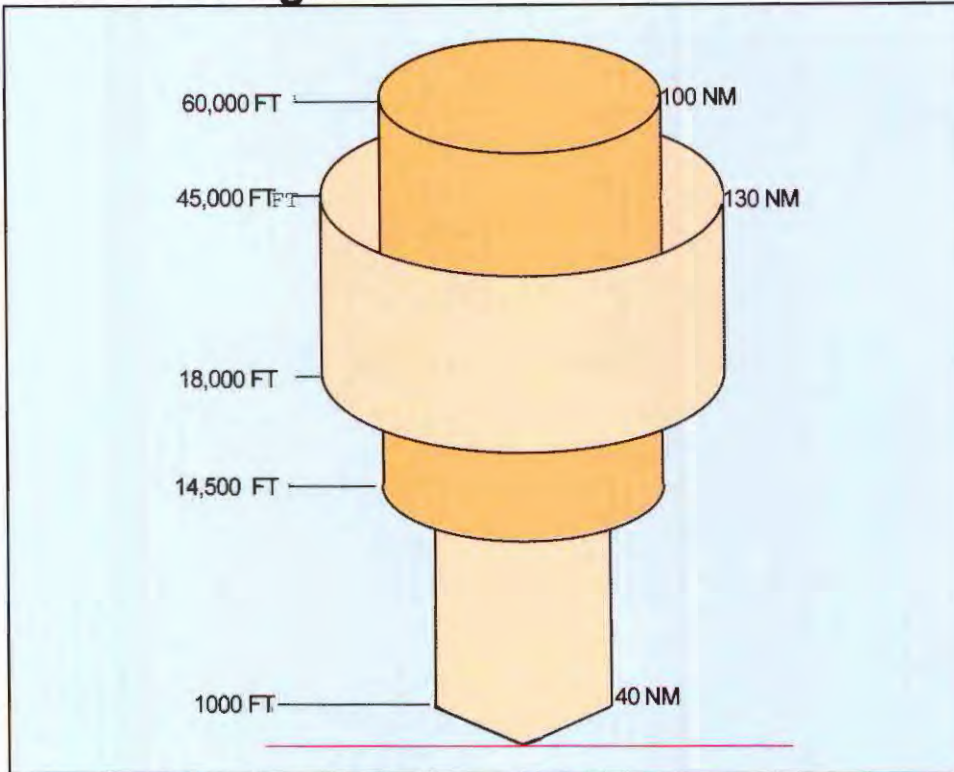

The service volume for a High Altitude (H) Vortac. Greatest range, where good signal reception is assured, is 130 naut miles between 18,000 and 45,000 ft. These are flight levels flown by turbine-powered aircraft during the en route phase. The three types of VOR are shown in the chart below.

VOR

VOR is the short-range radionavigation system for much of the world. When introduced in 1946, it eliminated interference problems of earlier systems. Radionavigation from 1920 to 1940 operated on low frequencies, where energy from lightning strokes are received over 100 miles away. Low frequencies are also susceptible to other natural and man-made sources.

Not until World War II could designers produce an airborne radio that operated at VHF (very high frequency) where there is little electrical interference. VOR frequencies start just above the FM broadcast band and run from 108 to 117.950 MHz.

VHF is immune to other problems of lower frequencies. The waves travel in straight lines like light, which is important for creating accurate courses. A well-designed VOR receiver can be accurate to within one compass degree.

VOR / DME / TACAN Service Volumes

T (Terminal VOR)

From 1,000 feet above ground level (AGL) up to and including 12,000 feet AGL, at distances out to 25 NM.

L (Low Altitude VOR)

From 1,000 feet AGL up to and including 18,000 feet AGL at distances out to 40 NM.

H (High Altitude VOR)

From 1,000 feet AGL up to and including 14,500 feet AGL at distances out to 40 NM. From 14,500 AGL up to and including 60,000 feet at distances out to 100 NM. From 18,000 feet AGL up to and including 45,000 feet AGL at distances to 130 NM.

VOR Signal Has Two Navigation Components: A “Reference” and “Variable” Phase

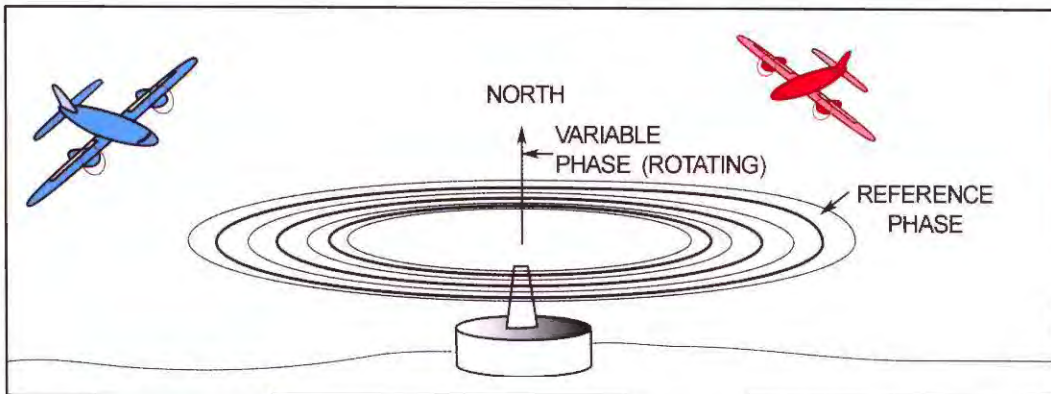

Each aircraft must receive two VOR signal components. One is the “reference phase,” which is broadcast in all directions. This is picked up by all aircraft lying out in any direction from the station. The reference signal is broadcast 30 times per second.

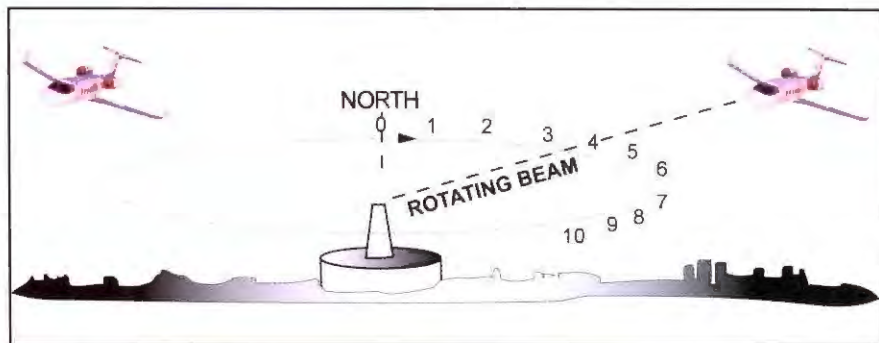

The VOR station also transmits a rotating beam that turns full circle. Because the beam is narrow it is intercepted only when the aircraft is aligned with the beam, as shown at the right. This “variable phase” signal is compared with the “reference phase” in the receiver.

As shown on the next page, the airborne receiver compares fixed and variable phases to determine the number of compass degrees, or bearing, from the station.

Short Range and Doglegs

VOR signals cover up to about 130 miles from the station. To travel from Los Angeles to New York, therefore, a pilot flies to and from about a dozen VOR stations. In continental U.S. there are about 1000 VOR stations on the ground. Because stations may not lie in a straight line along the route, the trip might have a “dogleg.”

RNAV. The delay of flying a dogleg was of not much concern when jet fuel was 17 cents a gallon, but as world prices rose in the 1970’s a new type of VOR navigation emerged. Called “RNAV,” for “area navigation,” it could receive a VOR off the straight line course and electronically move it on a desired course.

VOR Principles

A VOR station sends out two separate signals. One rotates like the narrow beam of a lighthouse. Imagine sitting on a beach at night, watching the beam go around; you see a bright flash only when the light points directly at you. At that moment, begin counting to see how much time it takes for the beam to flash again. Let’s say the beam takes 10 seconds for one rotation, or 360 degrees, and assume you’re sitting north of the lighthouse. Now you can convert the number of seconds into where the beam is aimed at any time. By counting five seconds from the flash, for example, you know the beam moved half-way around---180 degrees---and is aimed south.

VOR Signal Structure

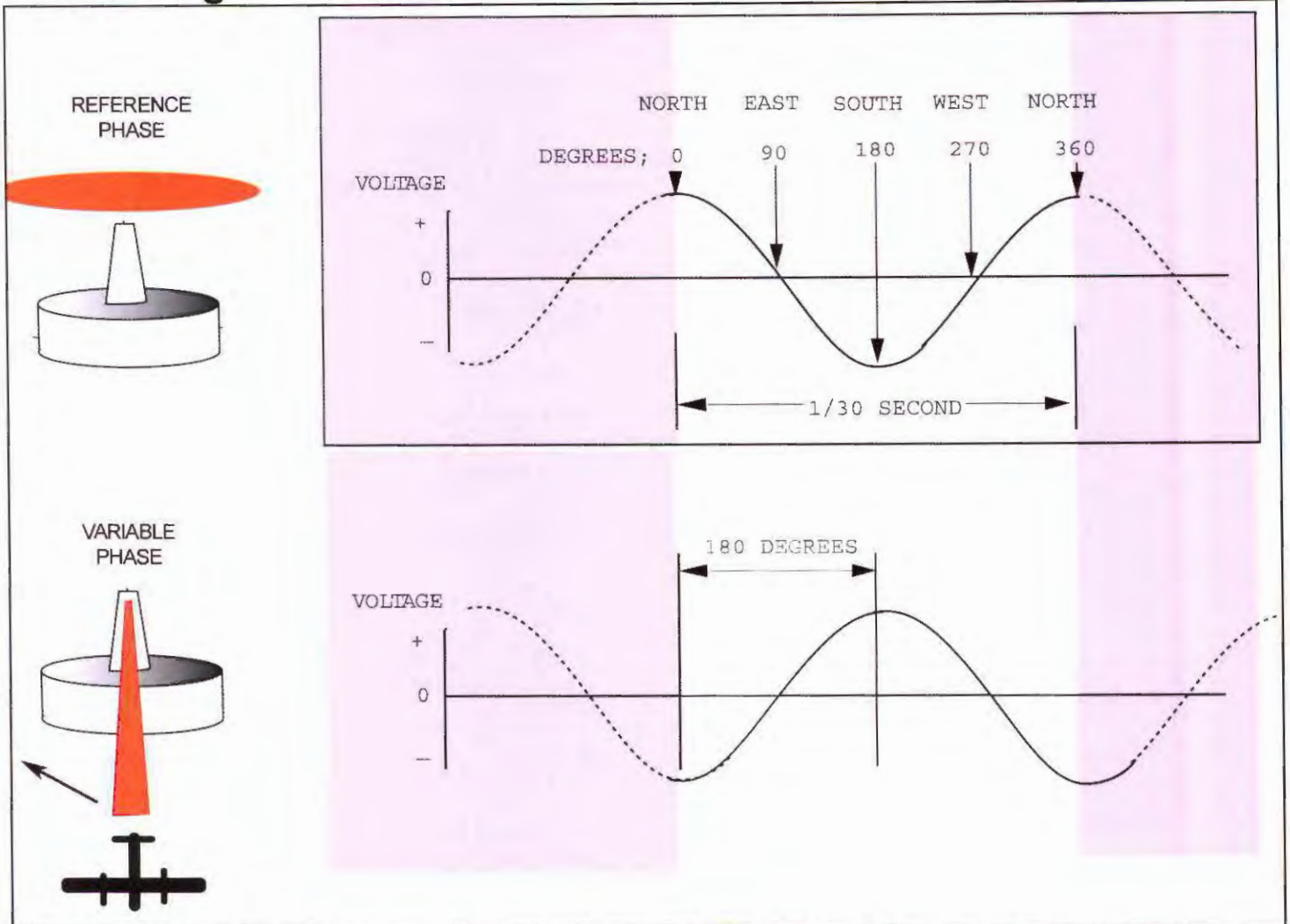

By comparing reference and variable phases, the VOR receiver determines a difference in degrees. This also becomes the magnetic bearing from the station.

In this example, the reference phase is at 0 (or 360) degrees. The airplane, south of the station, receives a variable phase signal of 180 degrees. The difference (360 - 180) is 180 degrees, or south.

The reference signal always goes through its 0 degree phase at the instant the variable signal rotates through magnetic north. This provides the correct reference for comparing the two signals.

A VOR also transmits two additional signals for station identification. One is an audio tone keyed in Morse code, enabling the pilot to identify the station. The tone is 1020 Hz.

The fourth signal is voice. Many VORs also broadcast voice to announce the ID, and enable the pilot to listen to the voice of a flight service station (for weather and flight plans.) The pilot, however, never transmits his voice on a VOR frequency because this would interfere with navigational signals. He transmits on another channel, and receives on the VOR frequency.

VOR Broadcasts Two Navigational Signals

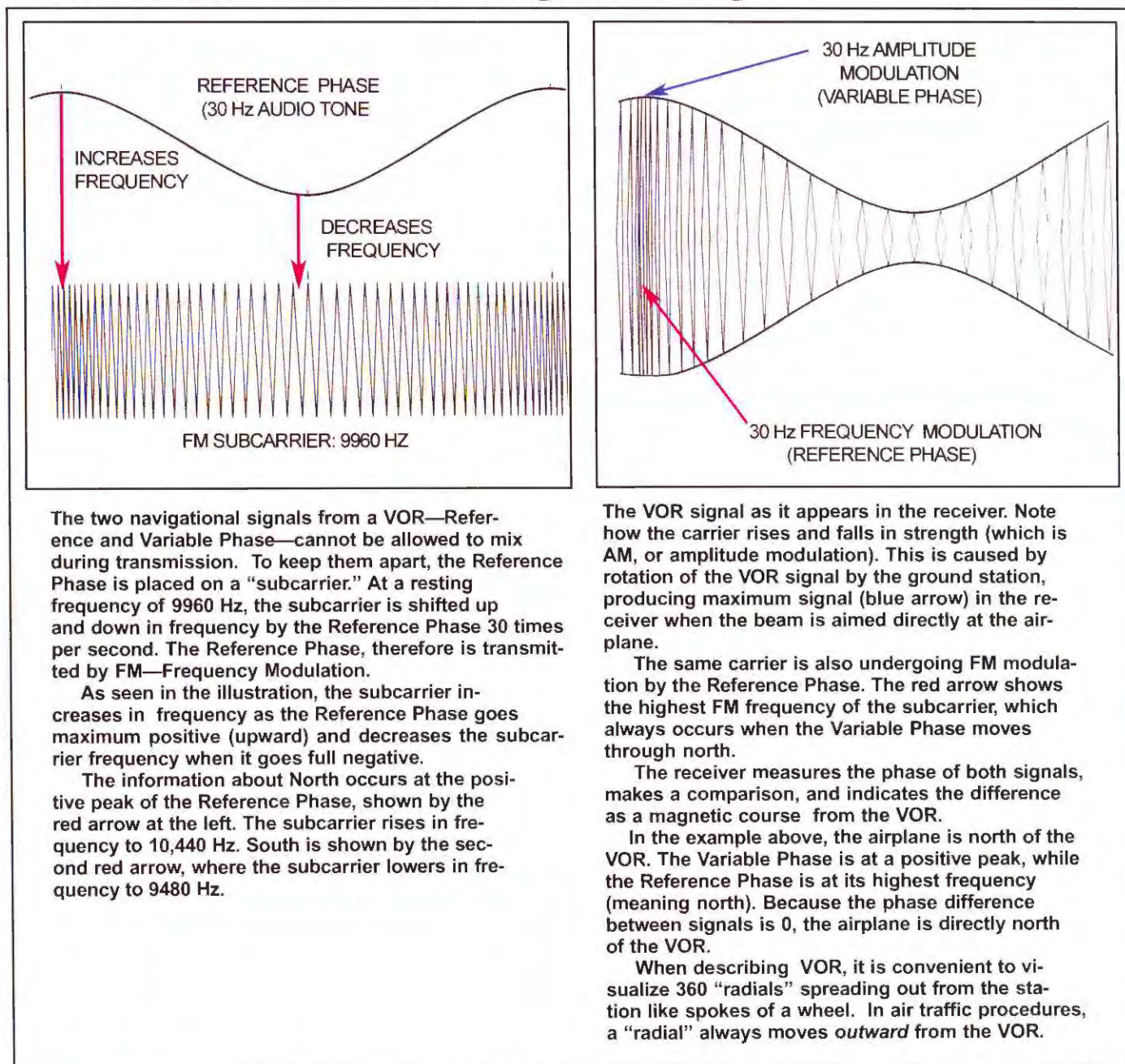

The two navigational signals from a VOR—Reference and Variable Phase—cannot be allowed to mix during transmission. To keep them apart, the Reference Phase is placed on a “subcarrier.” At a resting frequency of 9960 Hz, the subcarrier is shifted up and down in frequency by the Reference Phase 30 times per second. The Reference Phase, therefore is transmitted by FM—Frequency Modulation.

As seen in the illustration, the subcarrier increases in frequency as the Reference Phase goes maximum positive (upward) and decreases the subcarrier frequency when it goes full negative.

The information about North occurs at the positive peak of the Reference Phase, shown by the red arrow at the left. The subcarrier rises in frequency to 10,440 Hz. South is shown by the second red arrow, where the subcarrier lowers in frequency to 9480 Hz.

The VOR signal as it appears in the receiver. Note how the carrier rises and falls in strength (which is AM, or amplitude modulation). This is caused by rotation of the VOR signal by the ground station, producing maximum signal (blue arrow) in the receiver when the beam is aimed directly at the airplane.

The same carrier is also undergoing FM modulation by the Reference Phase. The red arrow shows the highest FM frequency of the subcarrier, which always occurs when the Variable Phase moves through north.

The receiver measures the phase of both signals, makes a comparison, and indicates the difference as a magnetic course from the VOR.

In the example above, the airplane is north of the VOR. The Variable Phase is at a positive peak, while the Reference Phase is at its highest frequency (meaning north). Because the phase difference between signals is 0, the airplane is directly north of the VOR.

When describing VOR, it is convenient to visualize 360 “radials” spreading out from the station like spokes of a wheel. In air traffic procedures, a “radial” always moves *outward* from the VOR.

The VOR receiver needs one more piece of information; when to start counting. This is the purpose of the second VOR signal (“reference phase”). When the first beam (“variable phase”) moves around and points to magnetic north, the second beam flashes in *every* di-

rection at once. All aircraft within receiving range of the VOR, no matter where they’re located, will “see” that North-identifying beam. Now when they receive the rotating beam some time later, they can calculate a magnetic direction to the station.

VOR Receiver

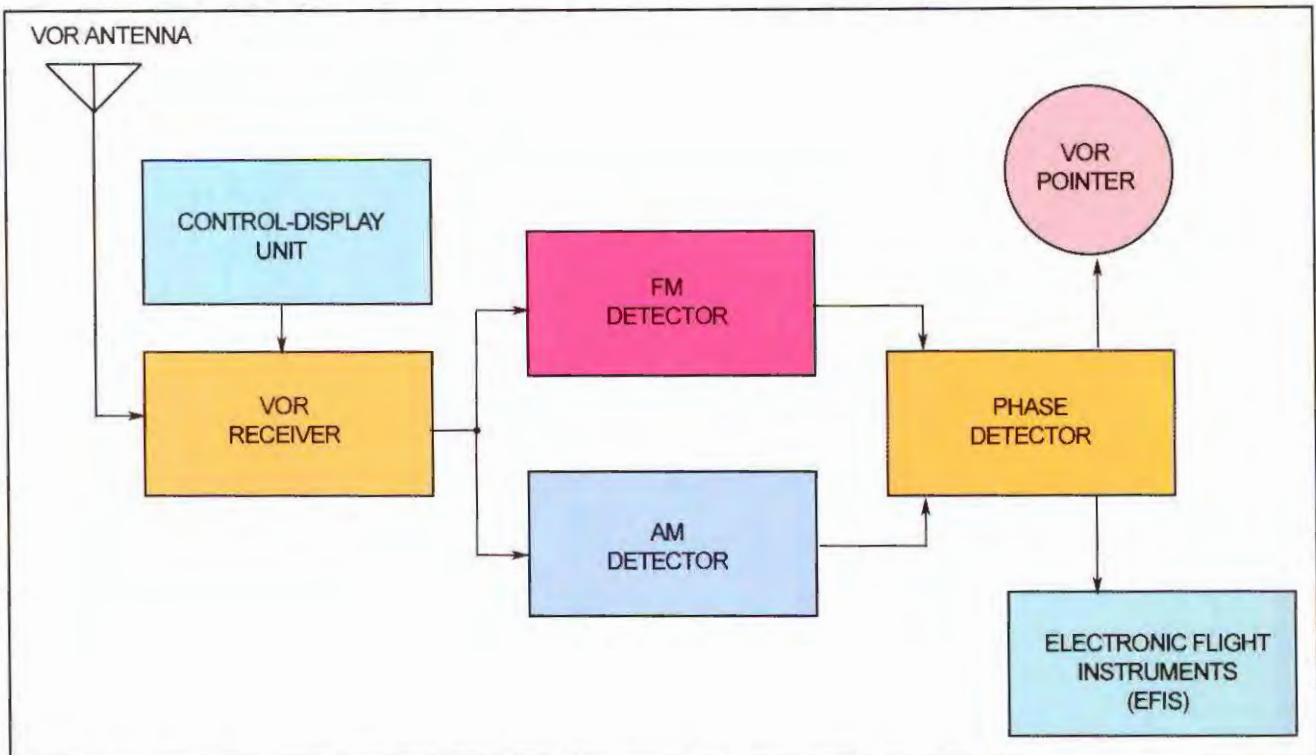

An airborne VOR receiver. Signals (from 108 - 117.95 MHz) enter the VOR antenna and are applied to the receiver. The receiver is tuned to a desired channel by the control-display unit. The FM and AM detectors process the two major signals transmitted by the VOR station; one on FM, the other on AM. The AM signals carry the "variable phase," the narrow beam which sweeps in a circle. The FM signal carries the "reference phase,"

which is broadcast in all directions. Each time the variable phase passes through north, the reference phase is at 0 degrees. The phase detector compares their phase and the difference is the number of degrees, or bearing from the VOR station. This information is displayed to the pilot on a VOR pointer or deviation bar on other instruments.

VOR Navigation

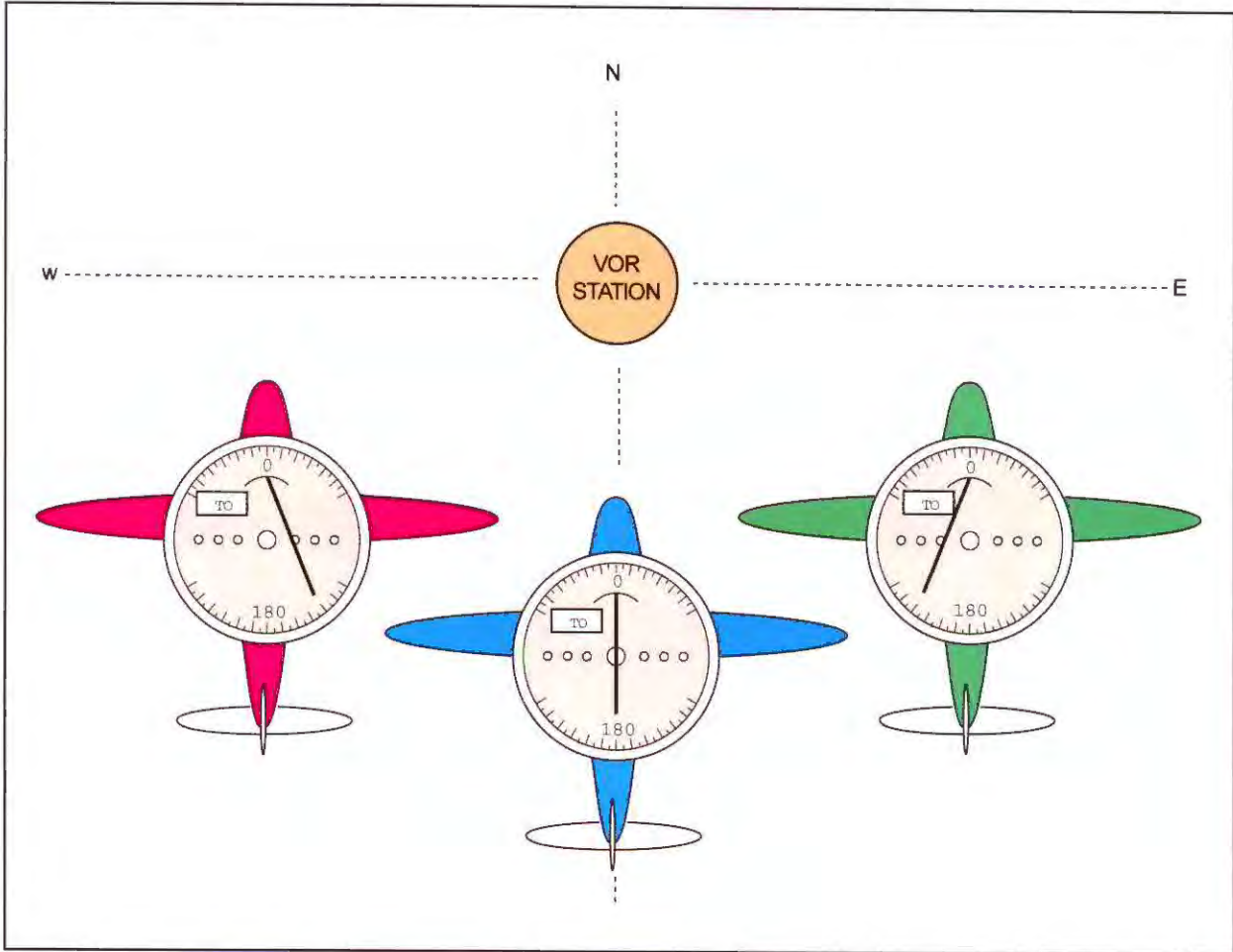

In VOR navigation, the pilot selects a desired course, in this example North (0 or 360 degrees). The airplane is south of the VOR station so the To-From flag (at upper left of display) indicates "To".

The airplane in the center is on course, so the needle is centered. The needles in the other airplanes show the direction to fly when the airplane is left or right of course.

These indications are not related to the heading of the airplane, as in Automatic Direction Finding (ADF).

There was early confusion over how to view the needle. Some pilots saw it as the airplane and steered toward the center circle---which is incorrect. The industry determined that, regardless of the instrument, the pilot should always "fly toward the needle" to get back on course.

When each of the airplanes crosses the East-West line, their To-From flags flip to "From."

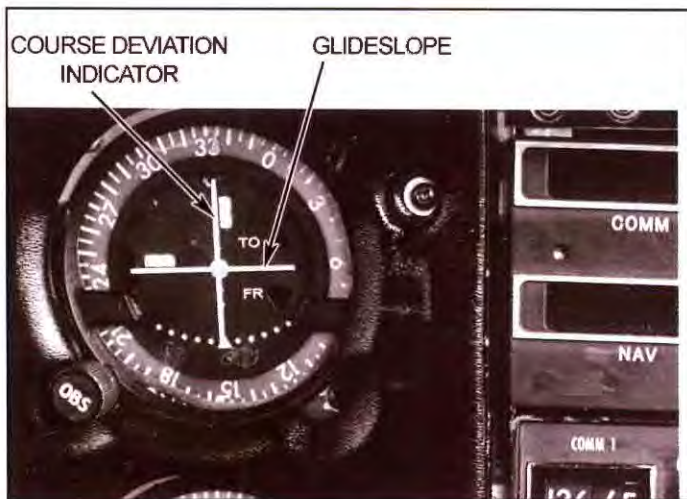

VOR indicator in a light aircraft. The course deviation indicator (CDI) gives left-right steering commands. Note "To" and "FR," which indicate whether the aircraft is flying to or from the station. For this to be correct, the course selected (shown here as 334 degrees) must generally agree with the course shown on a magnetic compass.

The VOR course is selected by the OBS knob at lower left (Omni Bearing Selector). The two white rectangles are flags which indicate if there is loss of reception.

The horizontal indicator, separate from the VOR system, is a glideslope needle used for ILS (Instrument Landing System).

VOR on Horizontal Situation Indicator (HSI)



AlliedSignal

VOR information is displayed to the pilot on an HSI (Horizontal Situation Indicator) found on large and high-performance aircraft. It gives a pictorial view of the airplane in relation to the VOR ground station. Note that VOR information is shown in green, for example; the pilot selected the No. 1 VOR receiver, shown at the left. He also adjusted the green course pointer to 20 degrees on the compass card, which is the desired course to the VOR station.

The airplane, however, is not yet on course to the station. This is shown by the green deviation bar split off from the course pointer. By turning the airplane to the right, the bar should move to the center and show the airplane on course to the station.

Radio Magnetic Indicator (RMI)

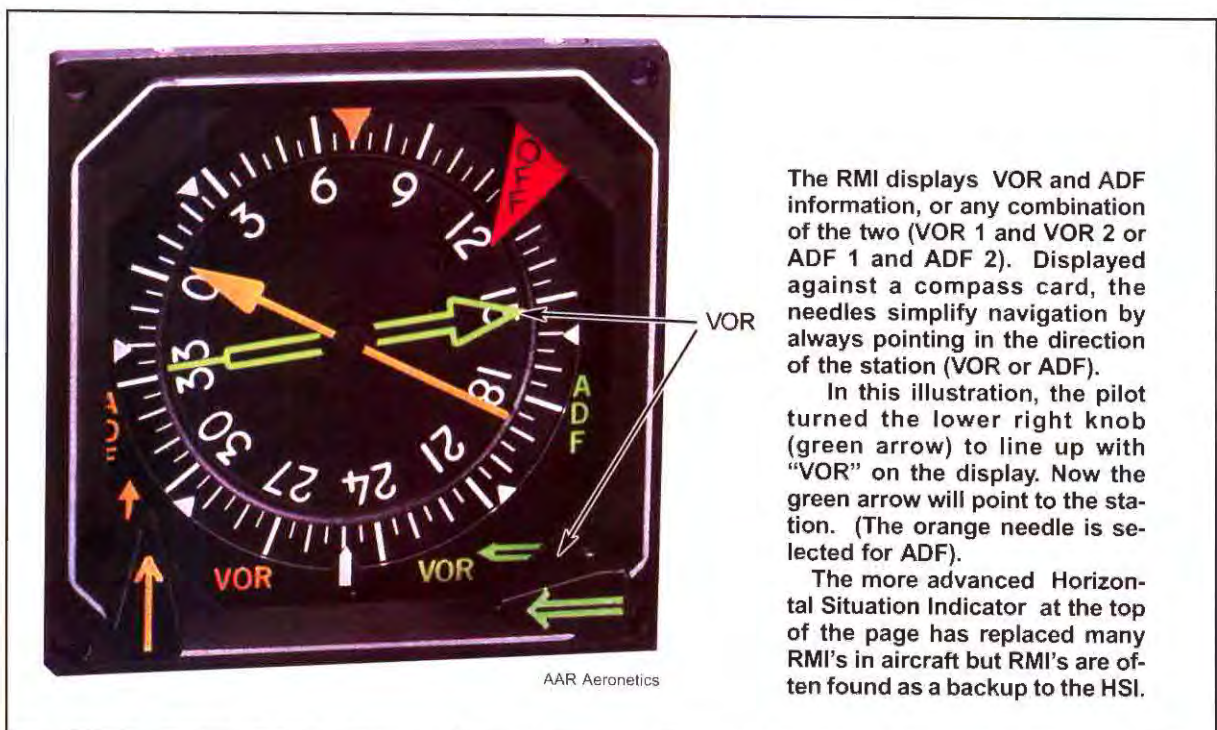

The RMI displays VOR and ADF information, or any combination of the two (VOR 1 and VOR 2 or ADF 1 and ADF 2). Displayed against a compass card, the needles simplify navigation by always pointing in the direction of the station (VOR or ADF).

In this illustration, the pilot turned the lower right knob (green arrow) to line up with "VOR" on the display. Now the green arrow will point to the station. (The orange needle is selected for ADF).

The more advanced Horizontal Situation Indicator at the top of the page has replaced many RMI's in aircraft but RMI's are often found as a backup to the HSI.

AAR Aeronetics

Nav Control-Display

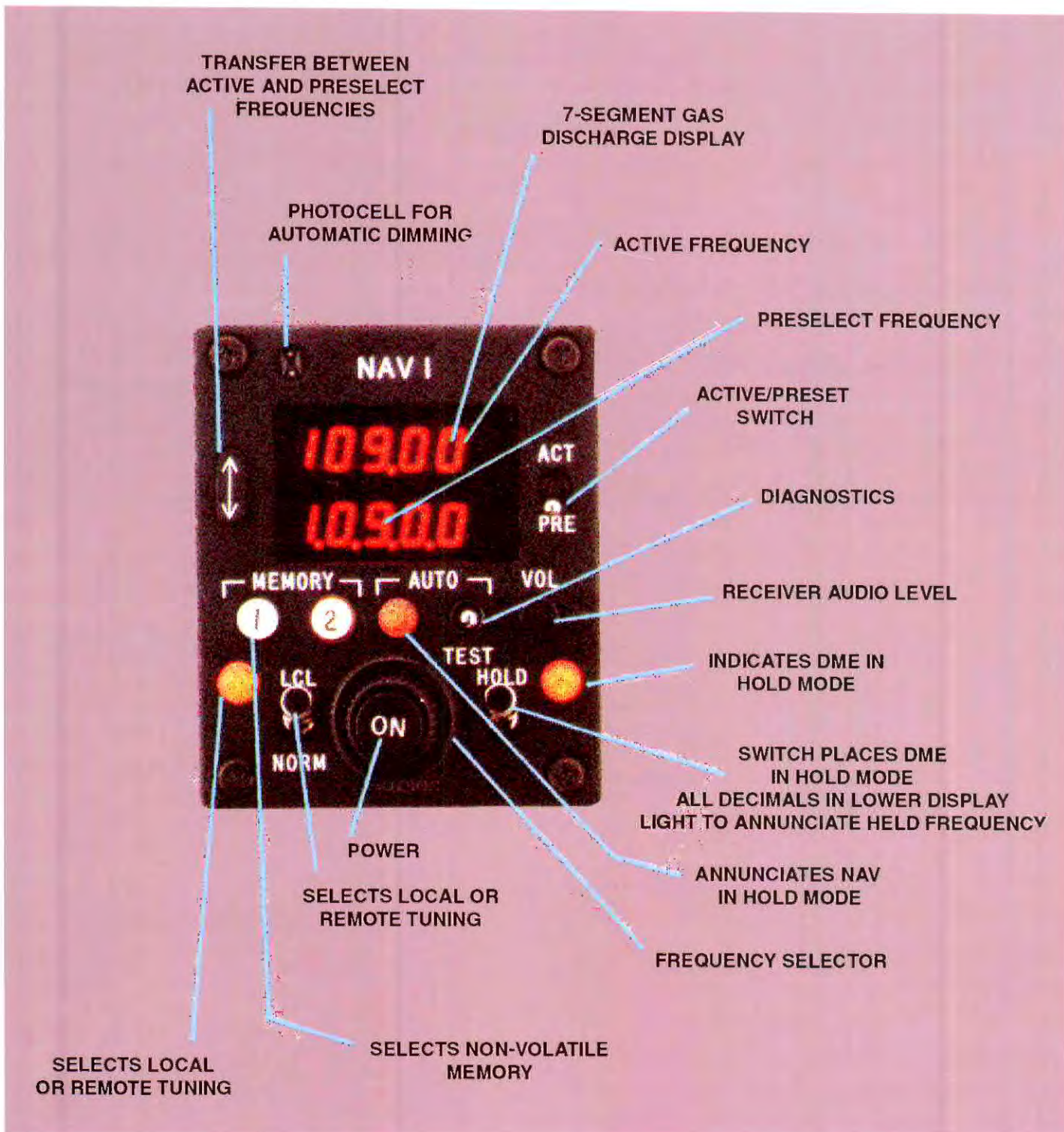

A control-display for a VOR receiver ("Nav 1"). Note at the lower left, the "LCL-NORM" switch, for local and remote tuning. The Remote position allows the radio to be tuned automatically by a Flight Management System.

Gables

Review Questions

Chapter 9 VOR

- 9.1 What is the name of a combined VOR and Tacan navigational station?
- 9.2 What problem of early radionavigation did VOR overcome?
- 9.3 VOR waves travel _____
- 9.4 Name the two major components of a VOR signal
- 9.5 The reference phase broadcasts in what direction?
- 9.6 The variable phase rotates _____ times per second.
- 9.7 What happens when the variable phase moves through magnetic north (0 degrees)?
- 9.8 How does the VOR receiver know its bearing from the VOR station?
- 9.9 Besides fixed and variable phase signals, what other information is broadcast by a VOR station?
- 9.10 Why is it necessary to place the reference phase signal on an FM subcarrier?
- 9.11 What is the purpose of the course deviation indicator (CDI) on a VOR receiver?

Chapter 10

ILS Instrument Landing System

The ILS is responsible for the ability of airliners and other aircraft to reach their destination more than 95 percent of time in bad weather. The system improves safety to such a degree that most airlines will not operate into airports without an ILS. In the business world, many corporations will not base their airplanes at airports without an ILS.

The ILS isn't only for bad weather. While descending into an airport at night at a brightly lighted city, pilots see a "black hole" where the runway surface should be. But a descent along an ILS glideslope clears all obstacles and brings the airplane safely within feet

of the touchdown zone. That guidance is also needed on bright summer days when an airport is hidden in haze.

Another benefit of ILS is that it provides a "straight in" approach. As airplanes become heavier and faster, there is more danger in maneuvering close to the ground at low airspeed. A 70-ton airliner cannot nimbly bank and turn through the right angles of an airport traffic pattern. But flying the ILS, the airplane "stabilizes" on the approach 30 or 40 miles from the airport and flies straight "down the slot."



An array of antennas launches the localizer signal near the end of an ILS runway. The beams are pointed toward an airport runway at the right and reach out to about 50 miles.

Airport Systems Int'l

ILS System

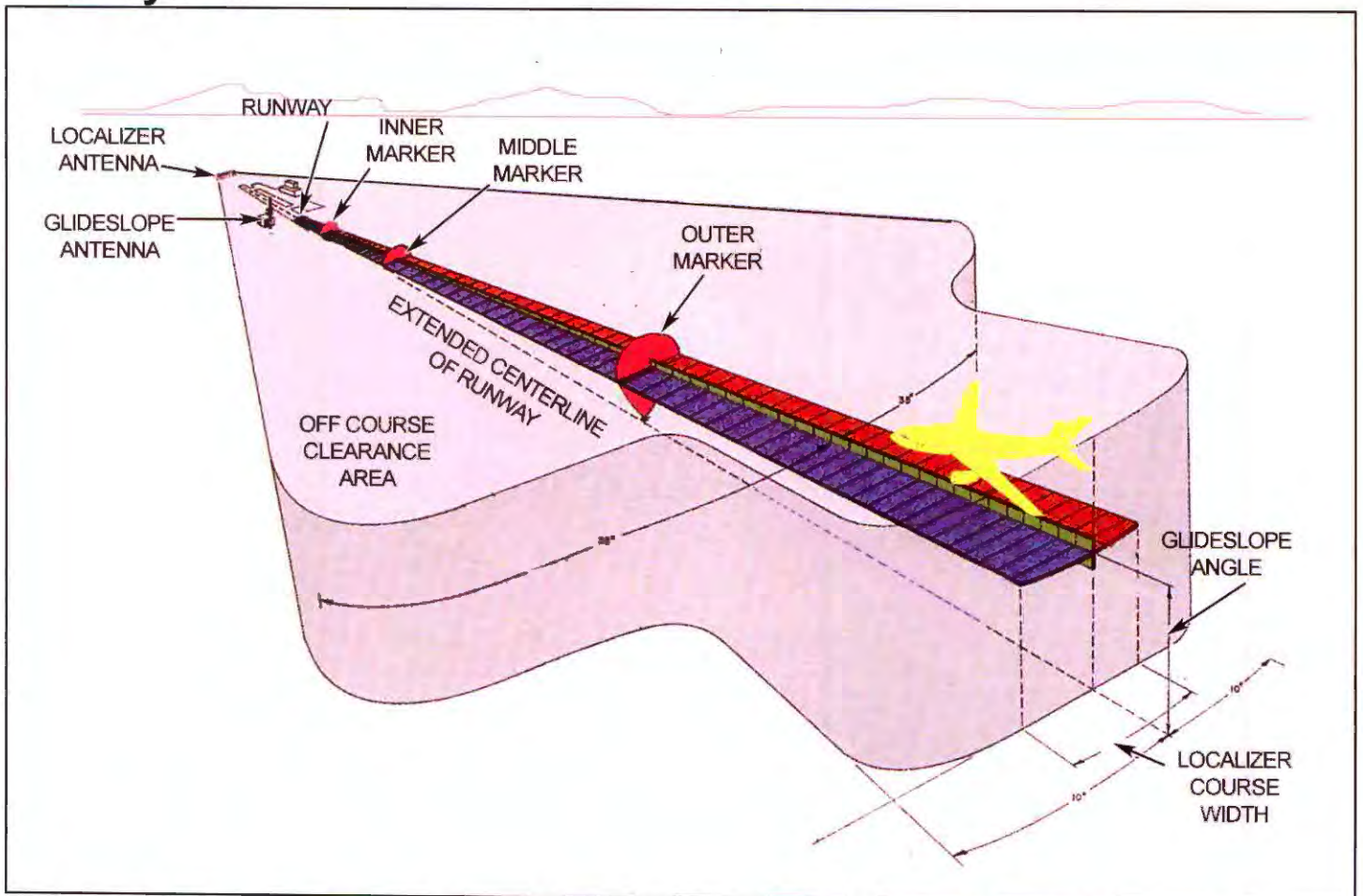

A three-dimensional path leads an airplane to the runway threshold at upper left. After intercepting the localizer (right), the airplane receives left-right guidance. At the

outer marker the airplane begins a descent on the glideslope. At the middle marker the pilot decides whether there is sufficient visibility to land, or perform a missed approach.

ILS Components

The ILS consists of more than a half-dozen systems, both aboard the airplane and on the ground. Each ILS fits in a category, depending how low the airplane may fly---known as "minimums"--- before seeing the runway and deciding to land. Even a few dozen feet have great impact on airline operations. If the ceiling, for example, is 150 feet and ILS minimums require a descent no lower than 200 feet, the airplane may have to fly to an alternate airport, deal with hundreds of unhappy passengers, miss connecting flights and disrupt schedules over the country. Similar problems face the overnight express industry (Fed Ex, Airborne, etc.). But with sufficient investment in avionics, training, maintenance and ground facilities, airplanes are unable to land at their destination only four or five days a year! (In the US, this usually happens when a low pressure area with clouds, fog and rain cover the East Coast.

ILS Categories

Because avionics in the airplane and ground stations must be equal to the ILS to be flown, consider the major divisions. The categories are based on ceiling and visibility at the airport when the airplane arrives. For ILS operations they are known as "Decision Height" (DH) and RVR (Runway Visual Range).

Decision Height. When the airplane descends to decision height (shown on an instrument approach chart) the pilot must decide whether to continue and land, declare a missed approach or go to an alternate airport. To continue the approach, he must be in a position to land (without excessive maneuvering) and see the approach lights or other visual component on the surface.

RVR (Runway Visual Range). Visibility is usually estimated by a weather observer and stated in miles. But the person may be more than mile from where the aircraft touches down, and visibility changes drastically

over short distances. To give the pilot an accurate report, visibility is measured electronically where the airplane touches down. It's done by a transmissometer, which sends a light beam between a transmitter and receiver. By measuring the loss of light (caused by haze or fog), it provides an RVR in feet. This informs the pilot whether the runway is below landing minimums for visibility. Here are the ILS categories:

Category I. By far the most common, there are approximately 400 Cat. I ILS airports in the U.S. The minimums are 200-foot decision height and RVR of 2400 feet. Typical equipment aboard the airplane to do this approach is a localizer receiver, glideslope receiver, marker beacon receiver and automatic direction finder (ADF) for receiving compass locators.

How the runway is lighted affects minimums. Lower visibility is allowed---an RVR of 1800 feet---if the runway has touchdown zone and centerline lights.

Distance Measuring Equipment (DME) is required for ILS procedures at some airports.

Category II. This ILS is installed at most international and large metropolitan airports. It brings decision height down to 100 feet and RVR to 1200 feet. In addition to avionics required for Cat. I, the airplane requires a second localizer and glideslope receiver and radar altimeter.

The last ILS category is divided into IIIa, b and c.

Category IIIa. Decision height drops to 100 feet and RVR to 700 feet. Additional avionics include an autopilot.

Category IIIb. Decision height drops to 50 feet and an RVR of 150 feet. A highly capable autopilot is required for this landing, one that can automatically flare (raise the nose of the airplane before touchdown) and decrab (straighten the airplane on the centerline).

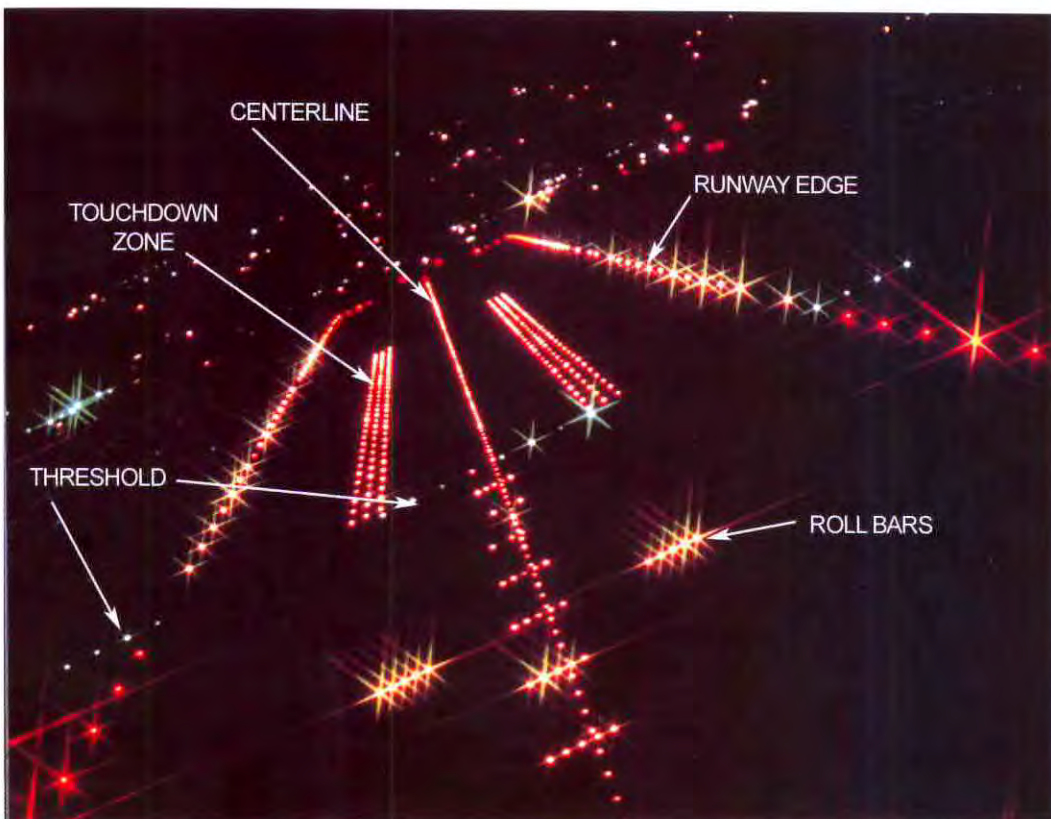

Airport Systems Int'l

Besides avionics, an ILS requires an approach lighting system. The pilot must be able to see the runway environment and make a visual touchdown and roll-out. Visual references are supplied by approach lights and runway edge lights, a requirement for a Category I landing.

For the runway to support Category II ILS

(with lower minimums), two systems are added; touchdown zone lights and the lighted centerline. Note the "roll bars," which serve as an artificial horizon during the last few seconds before landing.

Category IIIc, the fully "blind" landing, is where the pilot sees no lighting on the runway.

Flight Inspection and Monitoring



Airport Systems Int

A flight inspection aircraft is over the runway checking accuracy of localizer beams formed by the antennas below. The beams are also monitored by nearby receivers,

which sound an alarm if accuracy is lost. In advanced ILS systems, a defective localizer transmitter is switched off the air and a spare turned on.

The system is known as "autoland."

Although a Cat. IIIb landing is done in dense fog, there is just enough remaining visibility (150 feet) to roll out on the runway, then taxi to the terminal.

Category IIIc. This is the fully "blind" landing. Conditions are now "zero-zero" (for ceiling and visibility, meaning no decision height and no RVR). Even the weather report looks unusual; it reads "WOXOF," symbols that mean; "ceiling indefinite, sky obscured, visibility zero in fog." On this day, it is said, "Even the ducks are walking."

But let's assume the autopilot lands the airplane safely. Now the pilot has another problem; he cannot see to taxi to the terminal.

As this is written, there are no Cat. IIIc airports in the U.S. The fully "blind" landing, however, is not far in the future. Enhanced and synthetic vision guide a pilot without him seeing beyond the windscreen.

ILS Components

An ILS includes airborne and ground systems:

Localizer. From an antenna array on the ground, a localizer transmitter projects radio beams aligned with the centerline of the runway. The beams extend at least 18 miles out and to an altitude of 4500 feet. (Signals can be received much farther away, but are not guaranteed for navigation.) In the cockpit, the pilot is guided

to the runway centerline with an indicator that shows "fly right" or "fly left," until the needle is centered.

Forty channels in the VHF band are set aside for localizers. Because they lie from 108.1 - 111.95 MHz, they fall within the tuning range of the VOR receiver. ILS, however, is only on *odd-tenths* of the frequency, for example; 108.1, 108.3, etc. Localizer signals, therefore, are processed through much of the VOR receiver, then split off to their own detectors. When the pilot selects a localizer frequency, the receiver automatically configures for localizer processing.

The localizer transmits an audio ID for the pilot to verify the correct station. There is a Morse code identifier (which always begins with the letter "I").

Glideslope. The glideslope provides vertical guidance by sending beams at a typical angle of 3 degrees (to match the glidepath of the approaching aircraft).

There are no pilot controls for the glideslope receiver or audio ID. When a localizer is selected, the correct glideslope frequency is automatically channeled. There are 40 glideslope frequencies, each paired with a localizer. Operating in the UHF band, glideslope frequencies extend from 329.15 MHz to 335 MHz. The pilot knows the glideslope is operating by movements of the horizontal needle on the display or a no-signal warning from an indicator flag.

Marker beacon. Lying along an extended centerline of the runway, marker beacons give the pilot visual and

ILS: Two Audio Tones on a Carrier

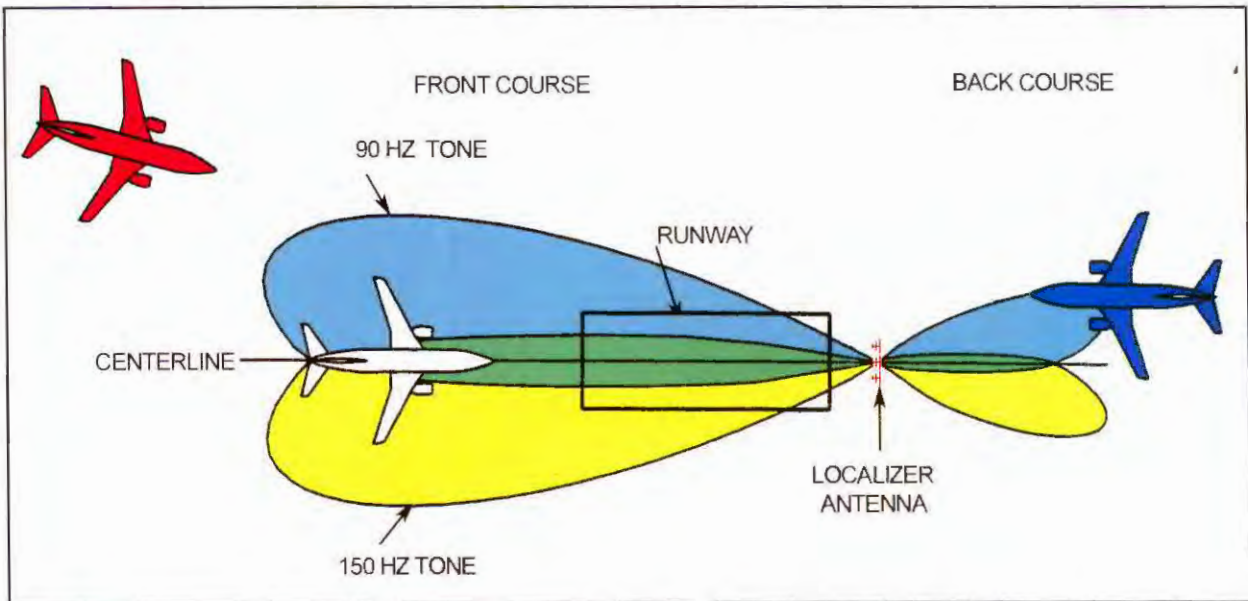

The localizer antenna focuses the radio carrier into two narrow lobes, shown here as blue and yellow. The yellow lobe is modulated with a 150 Hz tone; the blue lobe by a 90 Hz tone. If the airplane flies along the center of the overlapping (green) area, the pilot sees a centered ILS pointer.

An ILS receiver does not measure the difference in strength of the two radio lobes. Rather, the receiver compares the difference in strength between the two audio tones. This is known as "DDM," for difference in depth of modulation.

Many localizer antennas also launch signals off their back end (to the right in this illustration) and form a "back course." This can be used for limited guidance, but in simple localizer receivers, the needle indications

are reversed; the pilots flies away from the needle to get back on course (known as "reverse sensing"). Because this is confusing to the pilot, most localizer receivers have a back course switch ("BC") to keep the same sensing as on the front course.

Back courses are present at all localizers, but should never be flown unless there is a published procedure. Also, there is no glideslope with a back course approach.

Many localizer displays use the blue and yellow colors shown in the above illustration. The trend, however, is not to use these colors on an instrument because they don't provide useful information. The needle provides all the guidance.

Localizer Indications

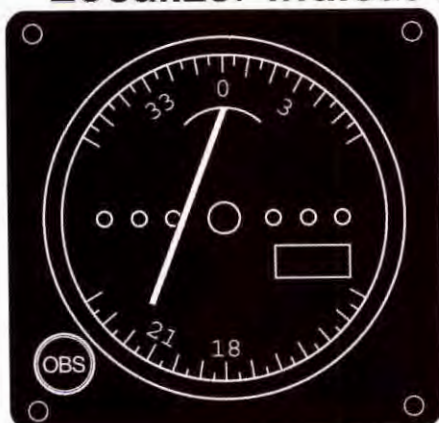

The localizer needle indicates "fly left" to intercept the centerline of the localizer course. When tuned to a localizer frequency, the OBS (omnibearing selector) is disabled. Most pilots, however, set it to the localizer course as a reminder. This example is Runway 36 (the same as 0 or 360 degrees).

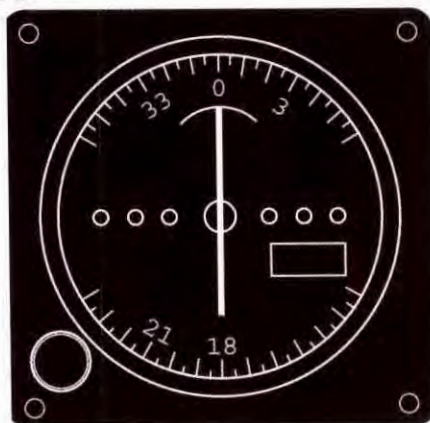

With the needle centered, the airplane is on an extended centerline of the runway. The same indicator is used for VOR navigation, but when a localizer frequency is selected, the needle become four times more sensitive. This achieves the higher accuracy required for an ILS approach.



The needle indicates "fly right" to get on the localizer course.

The overall width of a localizer course is usually 5 degrees. Thus, a needle deflecting full right or full left indicates the airplane is 2.5 degrees off the centerline.

Glideslope Guidance

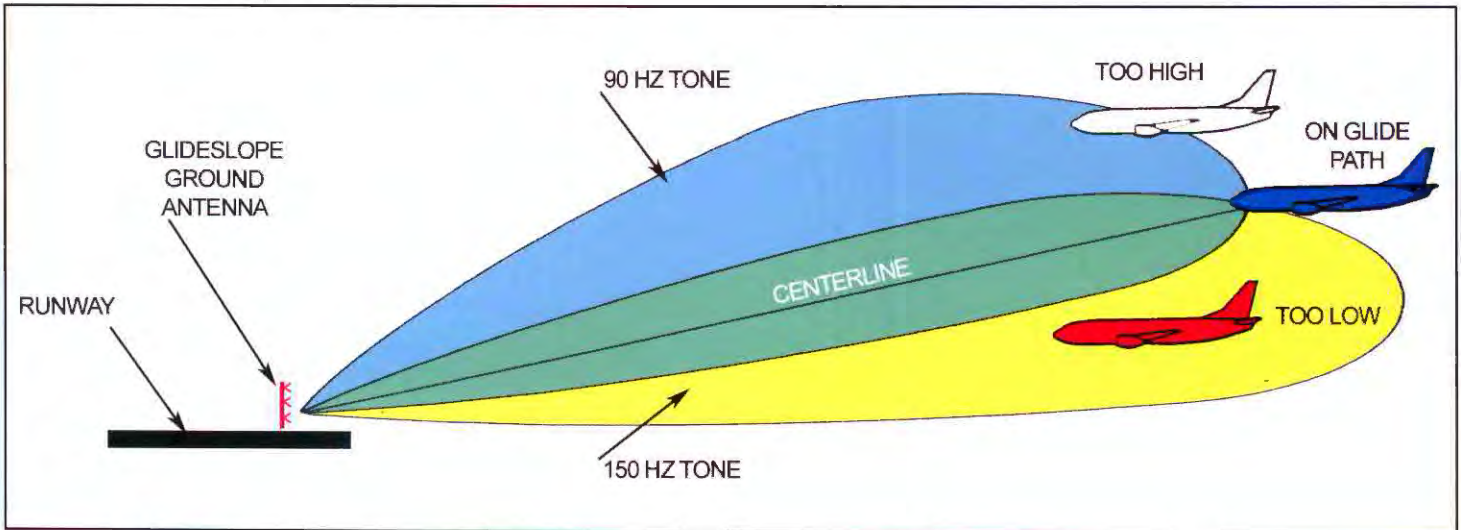

The glideslope is formed by a radio carrier aimed upward into the glidepath. The lobe seen in blue is modulated by a 90 Hz tone; the yellow lobe modulated by a 150 Hz tone. When the glideslope receiver

in the airplane receives equal signal (green area) it is on the glideslope. Most glideslopes are designed for glide angle of 3 degrees.

Glideslope Indications



Horizontal glideslope needle is below center of instrument, commanding pilot to "fly down" to intercept the glideslope.



Centered glideslope needle shows the airplane is descending on the correct vertical approach path to the runway.



The high position of the horizontal glideslope indicator is telling the pilot to "fly up" to intercept the glidepath. This is a dangerous situation because the airplane is too close to the ground.

audible cues on his distance to the airport over the last 4 to 7 miles. They are located to mark important phases of the approach, such as glideslope intercept, decision height and when to begin a missed approach.

Compass Locator. Some ILS approaches have a compass locator at the outer marker. This is a low power

station picked up by an ADF (automatic direction finder receiver) to guide the airplane, arriving from any direction, to the outer marker. Its operation is described in the chapter on ADF.

Glideslope Station

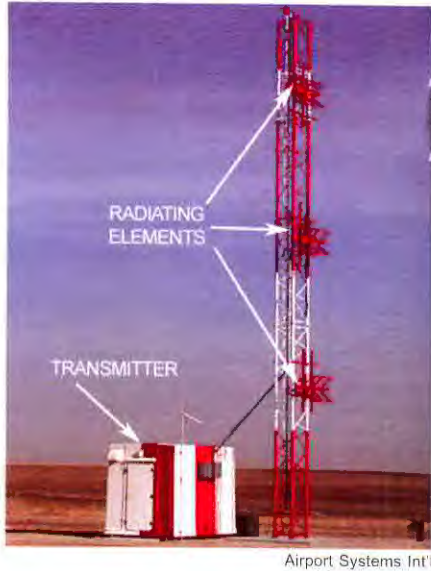

A glideslope antenna array, found alongside runways with an ILS, radiates signals that angle upward. When the airplane is about 5 miles away and 1000 feet above ground, the pilot intercepts the glideslope beam and flies it down toward the runway. Glideslope frequencies, which lie between 328 and 336 MHz are not selected by the pilot; they are automatically tuned when he selects the localizer frequency for that ILS approach. The glideslope receiver is "channeled" by the localizer receiver.

Glideslope Receiver

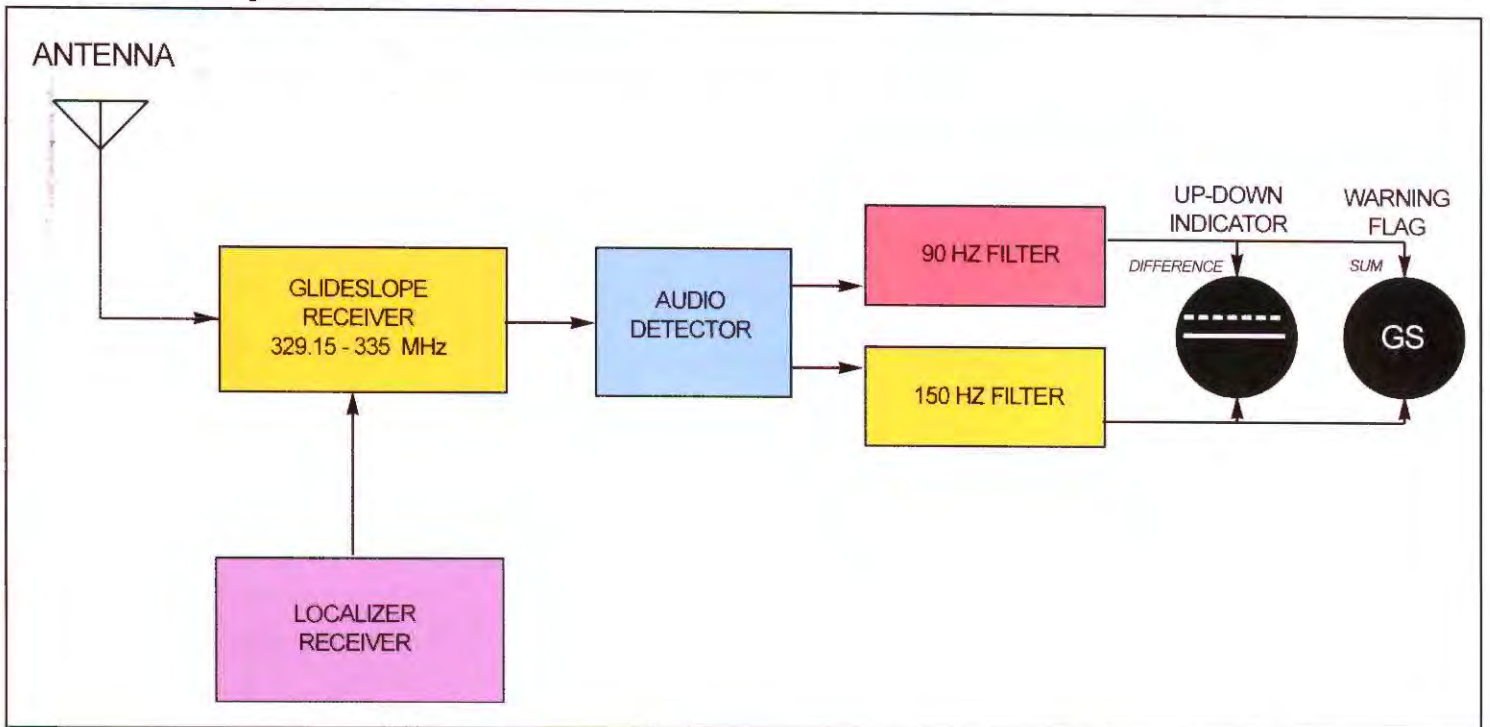

Up-down information is sent as two audio tones---90 and 150 Hz---which are recovered from the radio carrier by the audio detector. Two filters separate the signals.

The difference between the signals is presented to the up-down indicator. If the airplane is on the glideslope, equal amounts of 90 and 150 Hz are applied to the indicator, but out of phase (opposite polarity). The two tones cancel each other and the needle remains centered. This is correct for an airplane on the glideslope. If the airplane rises higher, however, the 90 Hz signal grows stron-

ger and moves the needle above the center position---telling the pilot to "fly down."

An important part of the system is the warning flag. If a malfunction causes loss of signal, the needle returns to the center position. This could be dangerous because the pilot might believe he is precisely on the glideslope. This is avoided by the warning flag. It receives the *sum* of the two signals; if they are not sufficiently strong for navigation, the flag appears. The warning usually shows the letters "GS" or a barber pole symbol (red stripes).

Marker Beacon Receiver

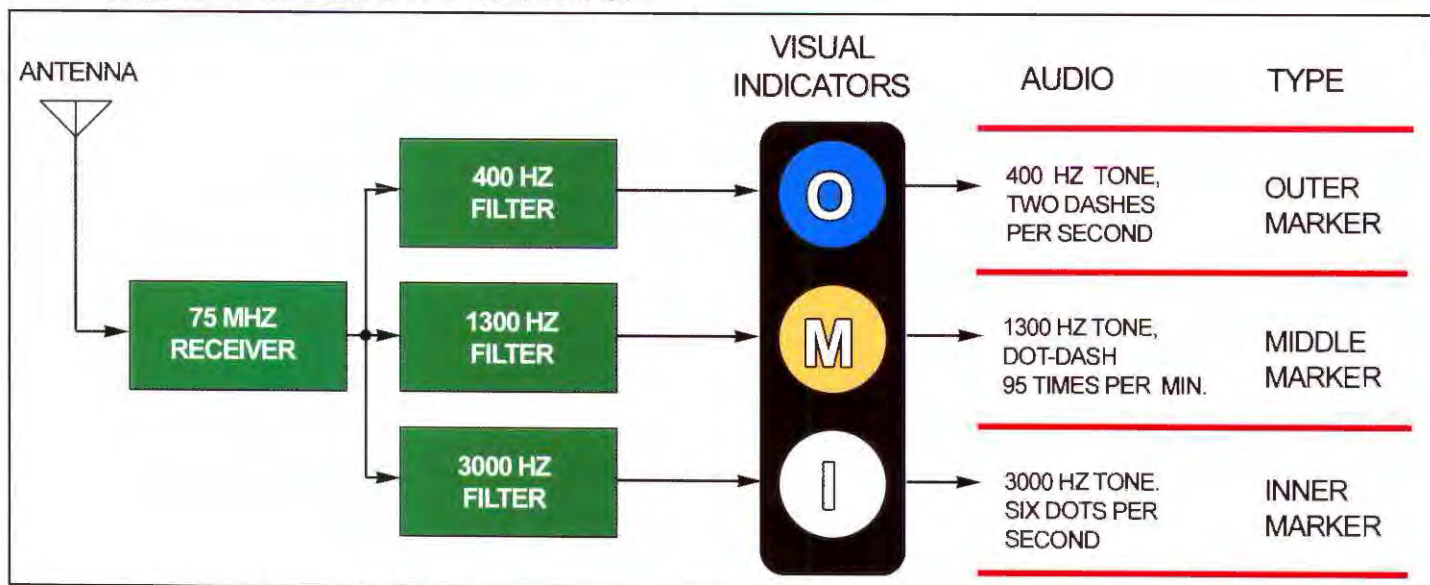

The marker beacon receiver is fixed-tuned to 75 MHz, the carrier frequency for all marker ground stations. The pilot identifies the marker by viewing the 3-light indicator (blue, amber and white) and listening for an identifying tone.

The audio rises in pitch and sounds faster as the airplane passes each marker and is closer to the runway. Most ILS's have only two markers; Outer (blue light)

and middle (amber light). The Inner marker is for Category II systems, which are at few airports.

On older aircraft, the white inner marker indicator may show the letter "A" instead of "I." "A" is for "airways," once used for cross-country navigation, but no longer needed because of numerous VOR stations. Its position is now occupied by the inner marker.

Marker Beacon Ground Stations

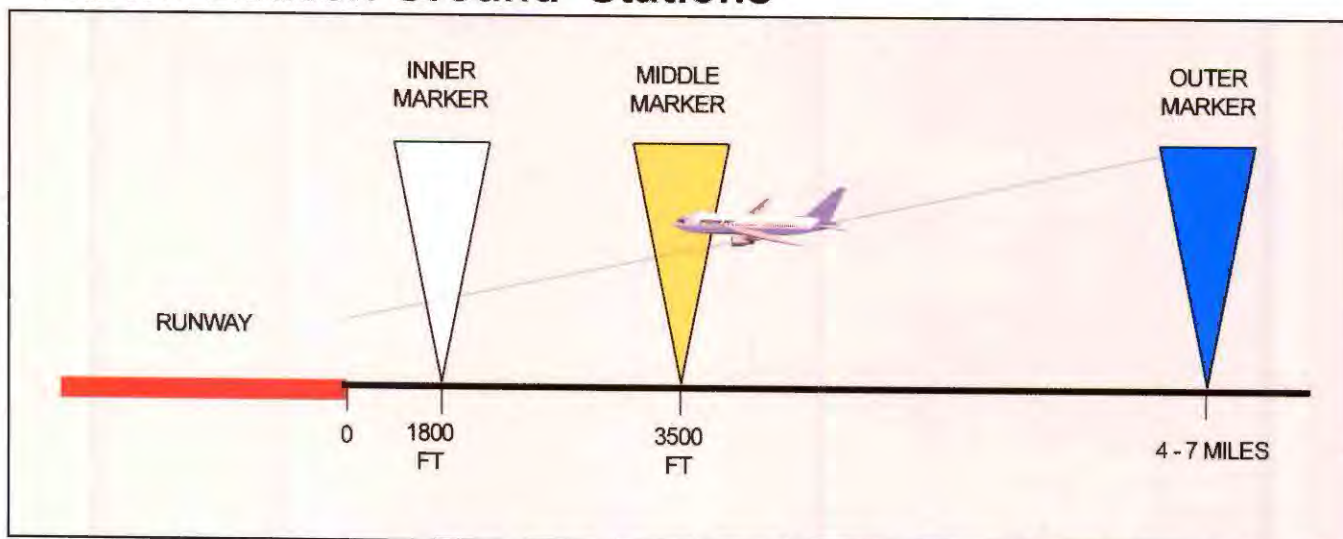

The three ground stations--- inner, middle and outer markers---broadcast on 75 MHz, but with different tone codes. Distances of the stations from the runway vary according to the airport location, but typical distances are shown in the diagram.

Markers broadcast very low power (about two watts) to keep their radiation close in and to limit their radiation to a small area. During an ILS approach, the airplane intercepts the glideslope signal at the outer marker. When

arriving at the middle marker, this is usually the decision height for a Category I landing.

Another function of the outer marker is to prevent the pilot from flying down a false glideslope. All glideslopes produce false signals above and below the correct one. The pilot knows he is on the correct one by checking on the approach chart for correct altitude when marker tone and light are received.

Review Questions

Chapter 10 ILS

10.1 Name three markers along an ILS.

10.2 How is RVR (Runway Visual Range) measured on an ILS runway?

10.3 Name the categories of ILS.

10.4 What component of an ILS provides an extended centerline to the runway?

10.5 Name the ILS component that provides vertical guidance to a runway.

10.6 How many channels are allocated to localizers?

10.7 The localizer frequency is selected on the _____ receiver.

10.8 The frequencies of the two audio tones that provide left-right guidance on a localizer are _____ and _____.

10.9 When a localizer frequency is selected on the VOR receiver, the indicator needle becomes _____ times more sensitive than for VOR navigation.

10.10. The frequencies of the two audio tones that provide up-down guidance on a glideslope are _____ and _____.

10.11 The compass locator of an ILS is received on the _____.

10.12 How are glideslope receiver frequencies selected?

10.13 What is the frequency for all marker receivers?

Chapter 11

MLS

Microwave Landing System

For over a half-century, ILS proved the most dependable system for landing airplanes in bad weather. But by 1960 there were signs that ILS could not keep up with a growing aviation industry.

Few channels. ILS has only 40 frequencies in the VHF band, with almost no chance for expansion. There are simply not enough frequencies to satisfy growth at large metropolitan and international airports.

Limited Capacity. An ILS serves one runway with a single course. When weather is bad, en route traffic headed for the ILS is strung out hundreds of miles, forcing each airplane to wait its turn for the approach.

Interference. The rise of powerful FM broadcast stations during the 1980's further threatened ILS. The FM band ends at 108 MHz, just under the beginning of the ILS band. One early complaint came from an Air Force pilot flying an ILS and monitoring the audio ID; "I hear music" he reported to the controller. An FM radio program was breaking into his ILS receiver. As more FM stations went on the air, it forced major design changes in ILS receivers to harden them against interference.

Terrain Problems. Installing an ILS at an airport is not simple. For ground antennas to function, they need a wide area clear of obstructions. ILS signals reflect and cause "multipath" error. (It's been said the cost of moving earth for ILS construction can cost more than the ILS equipment itself.) Some airports in moun-

Space Shuttle: Early MLS User



NASA

One of the first users of MLS was the Space Shuttle orbiter. Accuracy is important because approach and landing are "deadstick"---there is no engine power for the 300,000-pound "glider" to try a second time.

If necessary, the MLS system can perform an "auto-land," bringing the orbiter to touchdown and roll out on the runway. The crew may also fly manually with reference to instruments, guided by MLS signals. The approach begins at 18,000 feet and 10 miles from touchdown.

The orbiter carries three independent MLS receivers whose output is continuously compared and averaged. Distance to the runway is provided by precision-DME near the touchdown point.

MLS allows the orbiter to land in either direction on the runway.

MLS Azimuth Beam Sweeps Wide Area

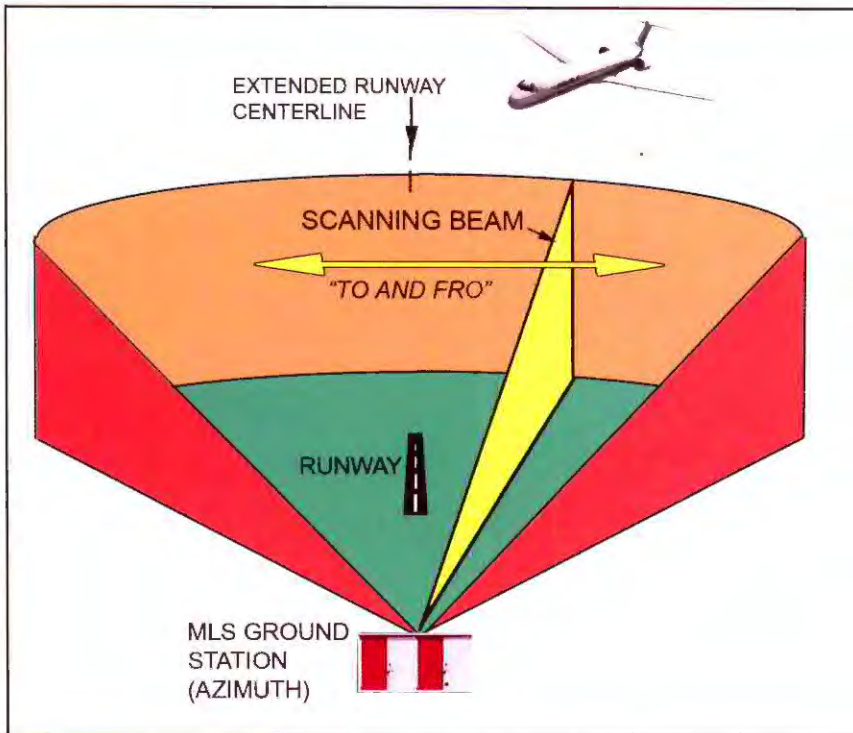

A narrow scanning beam from the MLS station sweeps back and forth beyond either side of the runway. An arriving aircraft picks up the sweeps ---"To" and a "Fro"--- and determines the time difference between them. From this information, the centerline of the runway is computed.

The approach to the runway does not have to be straight in. If the MLS receiver has flight management capability, a curved path may be computed and flown according to MLS guidance.

tainous regions can never have an ILS, which limits emergency medical aircraft, flights into ski resorts and other services. ILS cannot create the steep descent angles needed by a helicopter landing inside a city.

Military Operations. During the 1950's military services sought a new instrument approach system to fill their special needs. For tactical reasons, they relocate to new areas, clear the ground for a runway and quickly begin air operations. Air traffic must operate in and out of these remote fields under all weather and lighting conditions. It called for a new landing system that would fit in few portable cases, be flown in, set up, ready to land airplanes in about 15 minutes---and do it in all weather.

ILS fell far short of the goal. Its half-century-old technology required acres of open land and much signal tweaking to get the courses correct. ILS was also unsuitable for landing airplanes on aircraft carriers. Responding to military requirements, the avionics industry came up with MLS, the Microwave Landing System.

Shorter Waves. The first benefit of MLS arises from its wavelength. ILS frequencies have full wavelengths of about 8 feet. Much higher in the microwave region, signals are only 2.5 inches long (full wavelength). Not only are microwave antennas smaller, they are easier to form into a narrow beam and steered electronically.

As shown in the illustrations, the operating prin-

Transmitting MLS Azimuth Signal

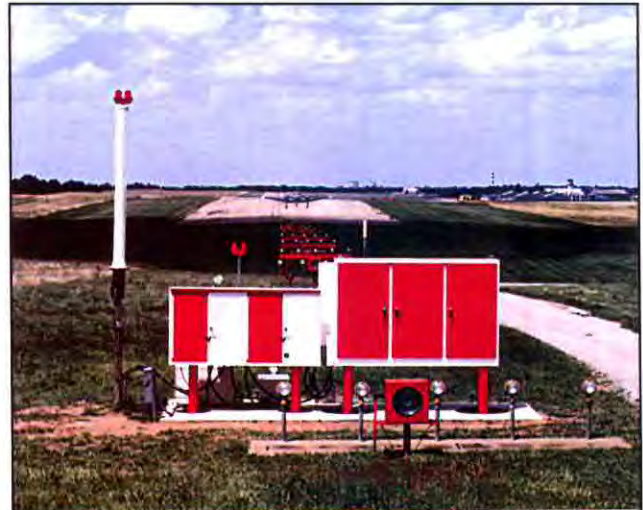

One of two major components of MLS is a ground station that transmits the "azimuth" signal. This is similar to the localizer of an ILS, but MLS sweeps a wide area beyond left and right sides of the runway. This provides many inbound courses to the runway.

The station is about 400 feet beyond the far (or stop) end of the runway, as seen by an arriving aircraft. The airplane on the runway is flight inspecting to check accuracy of the MLS signal.

The white tower at the left is a field monitor. From its position between the station and runway, the monitor continuously samples the MLS signal and warns of a malfunction.

MLS Elevation Beam Scans Vertically

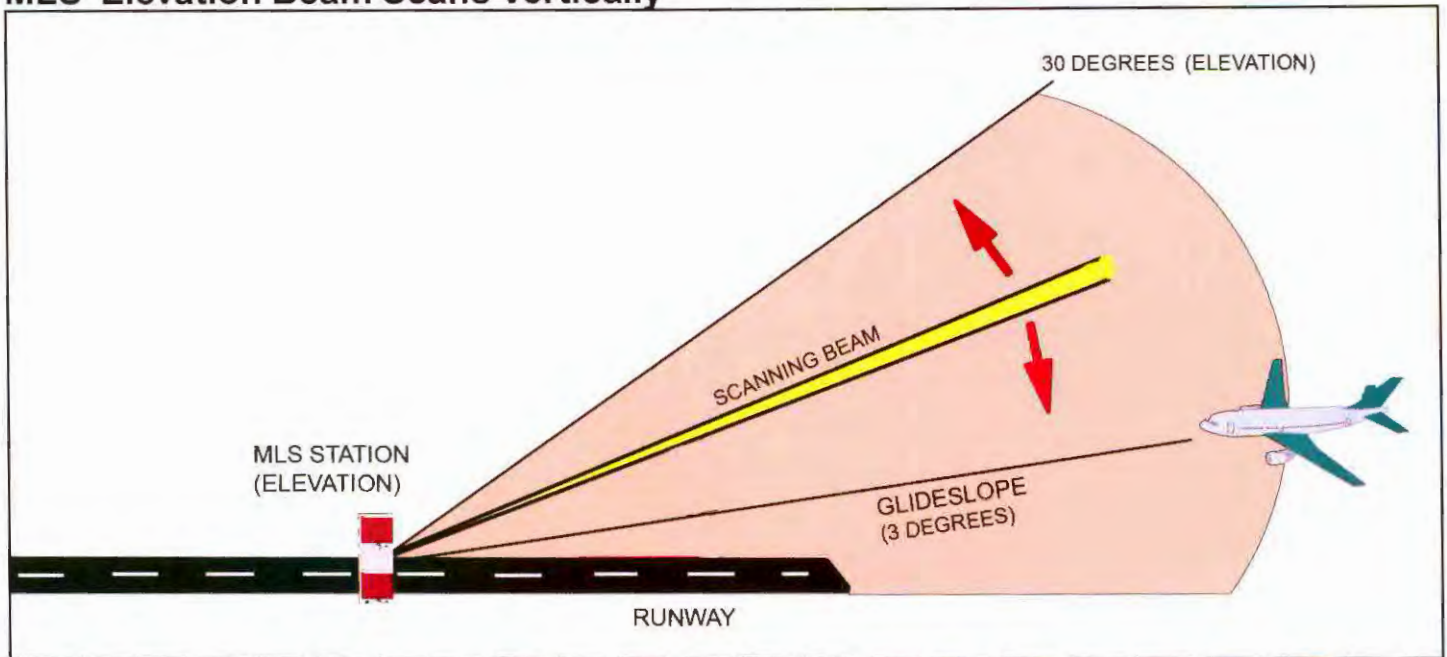

Scanning up and down, the MLS elevation beam is similar to an ILS glideslope. MLS, however, sweeps a greater area, creating many selectable glidepath angles. The arriving aircraft seen here chose a 3-degree glideslope, a typical approach angle for fixed-wing aircraft. A helicop-

ter, on the other hand, may choose a steeper glidepath in order to land on a rooftop in a city.

The MLS elevation station is located alongside the runway, near where aircraft touch down (about 400 feet from the approach end).

ter, on the other hand, may choose a steeper glidepath in order to land on a rooftop in a city. The principle is simple. The MLS station beams a signal that swings back and forth. An airplane receives the beam as the signal travels in the "To" direction, then again when the beam returns in the "Fro" direction. By measuring the time in between, the receiver calculates where the airplane is located with respect to the centerline of the runway. This is the "azimuth" function of MLS and is equivalent to the localizer of an ILS.

The same technique obtains the glideslope. Here, the MLS beams a signal up and down the approach path, and the receiver calculates a vertical glideslope.

Curved Approaches. Unlike ILS, the MLS signal provides three-dimensional navigation and new types of approaches. Those dimensions are elevation (glideslope), azimuth (localizer) and range, or distance, from the runway with precision DME. These dimensions are available over a wide volume, enabling the aircraft to arrive from many directions. It also provides all the data required for an onboard computer to create a curved or segmented (stepped) approach, which increases traffic capacity at an airport.

More Channels. In the microwave region, 200 channels were set aside by international agreement for MLS--which is five times as many as the 40 assigned to ILS. Relief from growing frequency congestion seemed at hand. Microwaves, too, are removed from interference of megawatt FM broadcast stations.



The MLS elevation antenna is near the touchdown zone of the runway. Also located here is P-DME, precision distance measuring equipment that accompanies an MLS installation. P-DME provides range to touch down and is ten times more accurate than conventional DME.

Another advantage of MLS is a pilot-selectable glideslope. A pilot may choose the glidepath to match his airplane performance.

The pilot is protected against selecting a glidepath that could lead to a collision with a mountain. Part of the transmitted signal contains a digital message which prevents the receiver from following a dangerous path.

MLS Time Reference

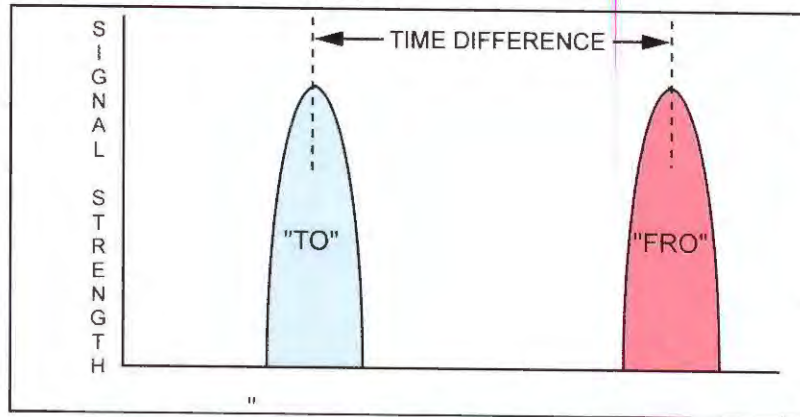

MLS signals arriving at the airplane produce two peaks as the beam sweeps back and forth over the receiver antenna. The centerline of the runway is determined by computing the elapsed time between the pulses. This method is used for both azimuth (AZ, or runway direction) and EL (elevation or glidepath).

The receiver knows whether it's receiving AZ or EL because each pulse is preceded by a short identification known as a "preamble."

The azimuth signal sweeps at the rate of 13.5 scans per second. The elevation signal scans 40.5 times per second.

Why the difference? A loaded Boeing-747 weighs 400 tons. If it lands six feet left or right of the runway centerline, it's probably not serious. But if the airplane flares 10 feet too high, the airplane may stop flying and drops to the runway for a hard landing. To avoid that, MLS updates the elevation (glidepath) signal three times faster than the azimuth for greater accuracy.

Preparing the Site. Microwave signals are less affected by terrain and nearby buildings. MLS ground stations do not need a large localizer array or tower for glideslope antennas. In one demonstration, a manufacturer loaded an MLS system aboard an airplane and flew it to an airport several thousand miles away. On arrival, the station was erected and instrument landing demonstrations followed almost immediately.

World Standard. That demonstration happened when the aviation world was deciding which of several MLS systems to approve as the international standard. The winner was TRSB, for "time referenced scanning beam," using the To and Fro method described earlier.

MLS was hailed as the replacement for ILS. Optimism ran high and, in 1978, the International Civil Aviation Organization adopted MLS as the new world standard. ILS would be phased out after a transition period.

Enthusiasm for MLS was so great that states like Michigan and Alaska did not wait for the government to install MLS at local airports and bought their own. A town in Colorado purchased an MLS as the only practical system to fly in skiers during bad weather. MLS would be the answer to precision approaches almost anywhere. At the same time, a new system appeared that changed the future of avionics.

Satnav. While the world awaited final approval of MLS, the US Department of Defense was examining a navigation system that had nothing to do with airplanes. The Department was seeking a method to

rendez-vous troops in the field---that is, troops finding each other in unfamiliar territory. The researchers envisioned a device to pick up satellite signals and provide guidance to down to 30 meters or better.

An important requirement was the receiver. It had to be lightweight, inexpensive and accurate. In a system called Navstar (Navigation with Timing and Ranging), they achieved those goals only today it's called GPS, the Global Positioning System.

MLS Survives. As GPS proved its value, aviation authorities dropped plans to replace ILS with MLS. Airline operators flying into congested airports, however, couldn't wait for a changeover to GPS, which could take ten years. As a result, MLS has enjoyed a limited revival, with installations in Europe, where high-volume traffic operates into international airports. There are MLS systems in the United Kingdom, Holland, Germany and France. Other countries in or near Europe are also planning to purchase MLS. On the military side, MLS continues to prove its worth as a tactical landing aid.

Multimode Receiver. Because airlines outside Europe must be equipped to land at any international airport, a new type of avionics appeared. It's the MMR, for "Multimode Receiver." It's a single radio that operates on ILS, MLS and GLS (for GPS Landing System). Once the radio is tuned to one of these services, the pilot sees the same guidance on the instrument panel.

Review Questions

Chapter 11 MLS

11.1 What were reasons for approving the Microwave Landing System?

11.2 MLS creates inbound courses to runways by a scanning beam which moves _____. This is called the _____ signal.

11.3 Glidepaths are created by a scanning beam which moves _____. This is called the _____ signal.

11.4 How does an MLS scanning beam determine

the centerline of a runway?

11.5 Why are there so few MLS installations at airports?

11.6 What type of receiver can use ILS, MLS and GPS signals?

Chapter 12

ADF

Automatic Direction Finder

The Automatic Direction Finder is one of the few air navigation systems that still operates in the low end of the radio frequency spectrum. The ground station, known as an NDB (non-directional radiobeacon) transmits from 190 to 1750 kHz, which spans the Low and Medium Frequency Bands. Despite many shortcomings, ADF is still an important component in instrument operations and will not soon be taken off the air.

ADF was a great step forward when Bill Lear (known for the LearJet) manufactured the first automatic direction finders during World War II. Before that time, a pilot or navigator turned an antenna loop by hand to find a bearing between the airplane and ground station. It's the same effect you hear on a portable AM radio; if the radio is rotated, there is a point where the station fades. You also notice that during one full rotation, there are *two* directions where the signal fades--which are opposite each other. The reason is, an antenna loop can only indicate a *line of position*; it cannot tell on which side of the station the airplane is located. This is known as an "ambiguity" and must be eliminated in order to fly toward the station.

Early navigators solved ambiguity by drawing lines of position from two different stations and fixing their position where the lines intersect. These systems, known

ADF on Fixed Compass Card



The simplest display is a fixed compass card and ADF pointer. To fly to the station, the pilot turns right and brings the pointer straight up. The fixed compass card is of limited value, only telling the pilot the relative (not actual) bearing to the station.

Radio Magnetic Indicator



A major improvement is the RMI, for Radio Magnetic Indicator. The compass card is coupled to a heading reference (such as a horizontal gyro), so the top of the card is always the actual heading of the airplane.

The RMI has two pointers, enabling the pilot to select any combination of VOR and ADF stations. In this illustration, selected are: yellow pointer for ADF, green pointer for VOR.

as MDF (manual direction finder) or RDF (radio direction finder) were crude and time-consuming for obtaining position fixes.

Lear's design made direction-finding automatic by recognizing that a radio wave consists of *two* components; an electric and magnetic wave. Radio waves, in fact, are known as "electromagnetic" energy. Before Lear, direction finders worked only on the magnetic portion of the wave, which is picked up by a loop-shaped antenna. If the loop is held with its wide, or open, side toward the station, the waves hit left and right sides equally. This generates little signal in the antenna because *equal* voltages occur on both the sides of the loop. There is no voltage difference, which is required to drive signal current down to the receiver. When the loop faces this way, its low-signal condition is known as a "null."

Next, turn the loop so one edge faces the station. Now the signal first strikes the forward part of the loop, then hits the back part. This causes a voltage difference in the loop and current flows to the receiver. This condition (high signal strength) is called the "peak."

The reason for the voltage difference is that a radio wave is rapidly changing, or alternating. In the distance between front and back parts of the loop, the wave moves through a different phase of its cycle, resulting in unequal voltages in the loop.

Sense

The ability of a direction-finding receiver to know which side of the station it's on uses the electric portion of the wave. To pick it up, a second antenna, called the "sense" antenna is added to the receiver. Unlike a loop, it picks the electric portion of the signal from all

Analog ADF

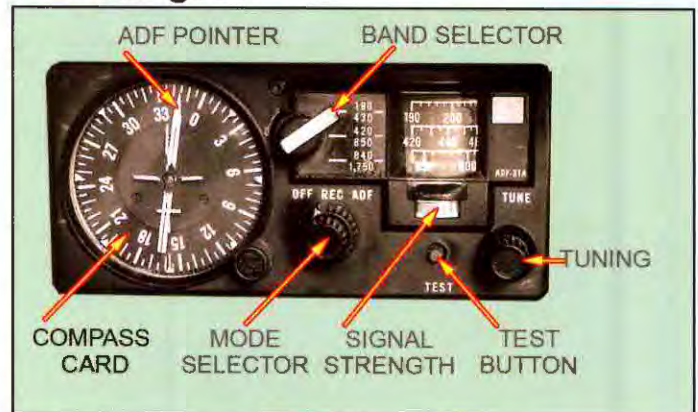

Early analog ADF receivers are still aboard many aircraft. The major items on the panel

ADF Pointer: When a station is tuned, the indicator points directly to the station, regardless of aircraft heading or flight path.

Compass Card: In this simple radio, the compass card does not move unless turned by the pilot.

Band Selector: Most aviation beacons are in the first band (190 - 430 kHz), and some fall in the second band (420 - 850 kHz). Most of the second band is for standard AM broadcast, which also occupies most of the third band (840 - 1750 kHz).

The ADF receiver navigates on both aviation stations (Non-Directional Radio Beacons) and AM broadcast stations.

Mode Selector. When the pointer is on REC (receive), the radio uses only the ADF sense antenna, and the radio acts as a conventional AM receiver. When placed on ADF, the receiver uses both sense and ADF loop antennas and operates as an automatic direction finder.

Signal Strength. As the pilot selects a station with the Tune knob, the meter helps find the strongest signal.

Test Button. To determine if the ADF pointer is not jammed or inoperative, the button is pressed. The test causes the pointer to swing at least 90 degrees and return when the button is released.

ADF System

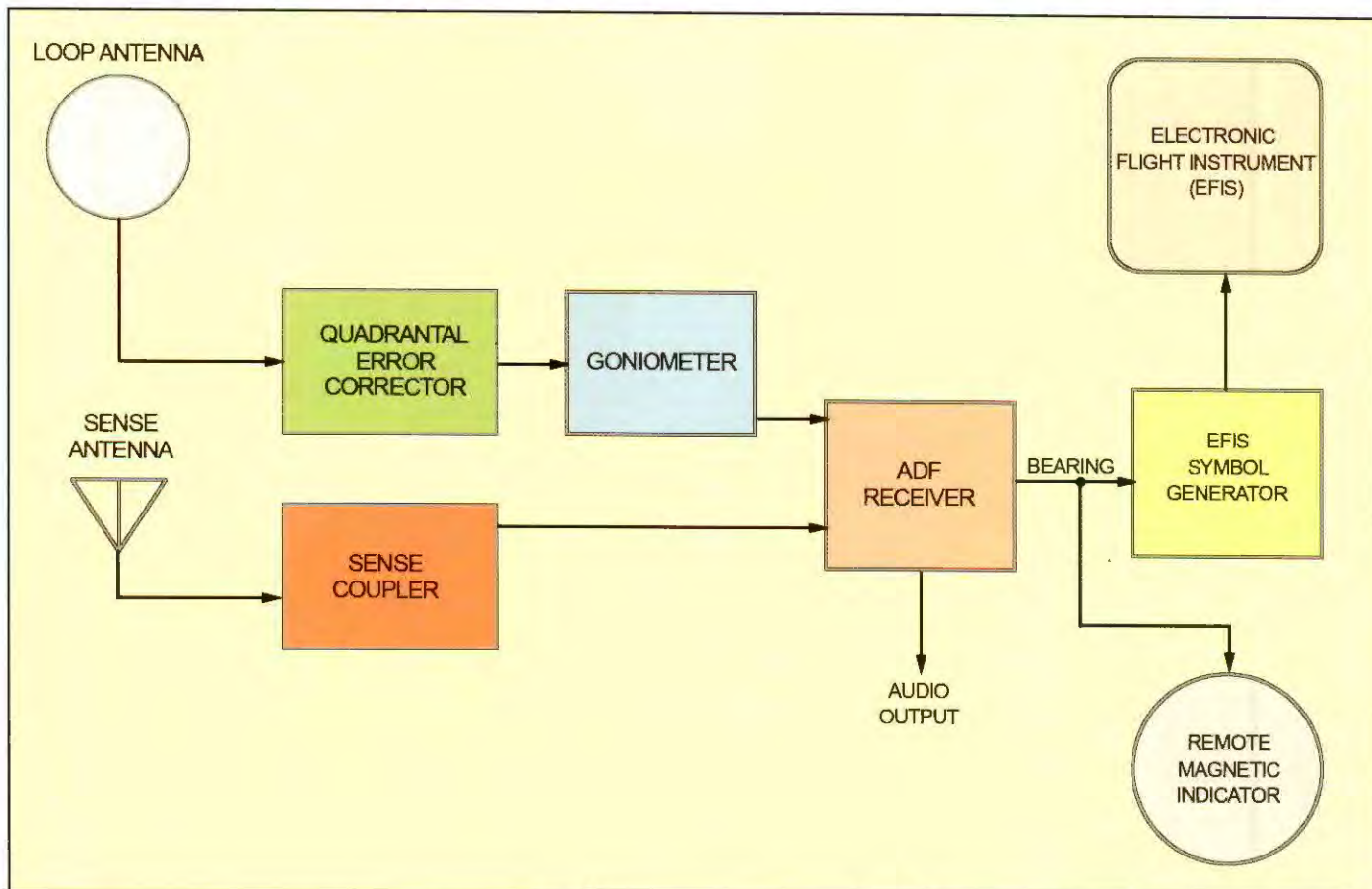

The Loop Antenna is highly directional, but metal areas on the airplane distort its pattern. This is corrected by adjusting the Quadrantal Error Corrector.

The Goniometer captures the incoming signal and produces angle information which is fed to the ADF Receiver.

Also feeding the receiver is a Sense antenna. It is not directional, but mixes with the Loop Signal to remove the "ambiguity." Otherwise, the loop would indicate only a line of position that could run to or from the station.

directions. By combining loop and sense signals in the receiver, the correct direction of the loop signal is selected and the indicator points toward the station.

The receiver uses the null portion of the loop signal, not the peak, because it produces a sharper, more accurate directional indication.

Lear's first ADF's automatically turned the loop to home in on a station, but required motors and mechanical components. Today, the antenna is made of "crossed loops," two coils on ferrite cores placed at right angles to each other. They feed their signals to a *goniometer*, a device which compares them and produces bearing information. The loops now remain stationary and have no moving parts. Instead of a large circle of wire inside a dome, today's small loop antennas barely protrude from the surface of the airplane.

The sense antenna began as a long wire strung above the fuselage, a system that would hardly work at

The sense system eliminates the incorrect direction.

Bearing-to-station information developed by the receiver is fed to an EFIS symbol generator. This creates the symbol of an ADF pointer on the electronic display.

Bearing information may also be applied to a Remote Magnetic Indicator (RMI), an older, electromechanical instrument.

Audio from the beacon station (voice, Morse Identifier) is sent to the aircraft's audio panel.

the speed of jet aircraft. The sense antenna on an airliner is often part of a plastic fairing near the wing root. The fairing is covered with a thin coat of metal to form the sense antenna.

NDB Station

There are several classes of ground station for non-directional radiobeacons (NDB), mainly depending on broadcast power. The lowest wattage NDB is part of the Instrument Landing System (ILS) where it is known as a "compass locator." It guides the pilot to the outer marker or final approach fix at about 30 miles from the airport. For cross-country flight, NDB stations generate 100-400 watts and reach out 50-100 miles. When an NDB is located near a coast, power may rise over 1000 watts to provide long-range guidance over water for several hundred miles. One NDB on Bimini Island near Florida, for example, covers most of the Caribbean.

ADF Control-Display: *Airline*

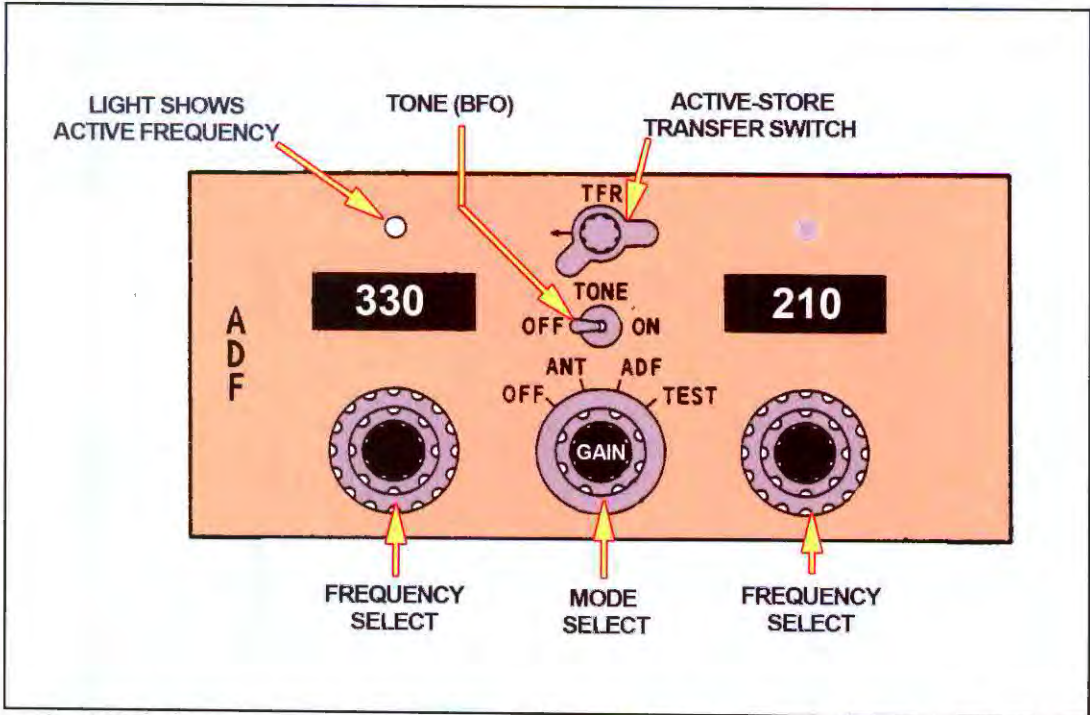

The ADF display has two sides; for active and stored frequencies. The indicator light (above left) illuminates to show which side is active. A transfer switch provides an instant changeover.

The "Tone" switch near the center is the same as the "BFO" (beat frequency oscillator) on other ADF displays and serves the same purpose; to make the ID audible on stations that don't transmit audio tones.

ADF Receiver: *Airline LRU*

The remotely located ADF receiver has a test function that checks for correct movement of an ADF indicator.

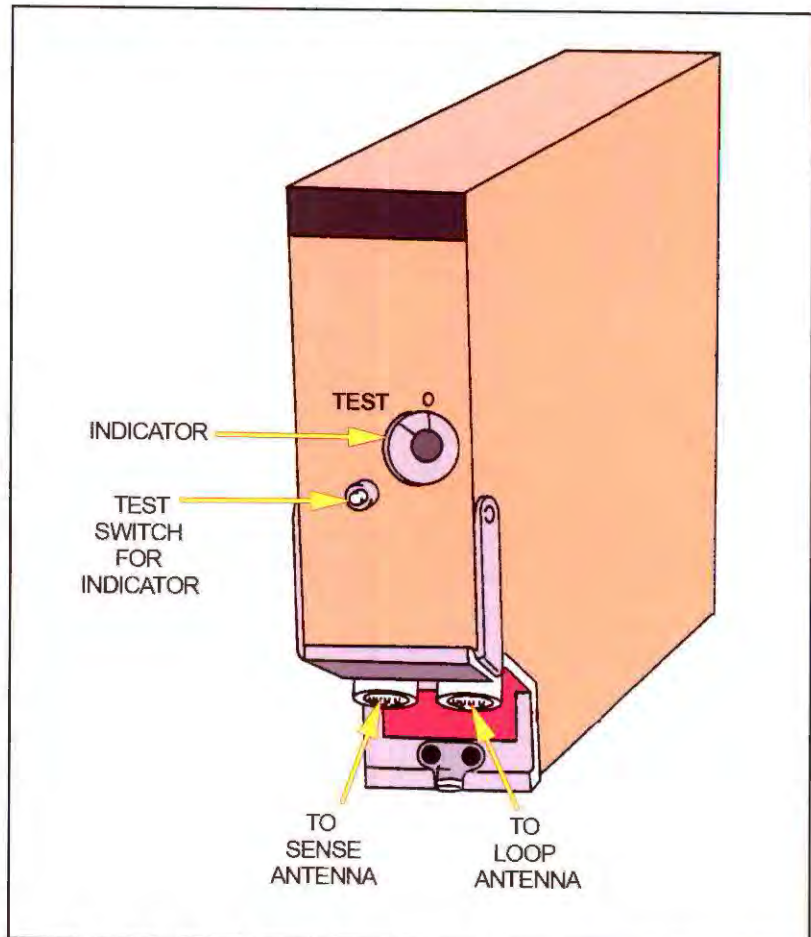

NDB stations transmit their identification in Morse code (two or three letters) by modulating the radio carrier with an audio tone. Some high-power NDBs carry continuous aviation weather reports by voice. There may be NDBs in remote areas with no audible tone for identification. Instead, they key the carrier on and off to form Morse code. ADF receivers have a circuit (BFO, for beat frequency oscillator) to generate audio for these stations.

Broadcast Stations

Because an ADF receiver can tune the standard AM broadcast band (530 - 1700 kHz) it can also home in on those stations. The signals may not serve as airways in instrument operations and not be depended on for navigation. AM stations are difficult to identify because they announce their call letters at wide intervals. Also, many AM stations shut down at sunset.

ADF Limitations

Electrical Interference. Operating on low and medium frequencies subjects the ADF receiver to natural and man-made interference. It is also susceptible to noise from rotating machinery aboard the aircraft, such as alternators, generators and magnetos. Several techniques are needed to suppress it, such as shielded cables, filters, bypass capacitors and grounding, as described in the chapter on troubleshooting.

Natural sources of interference include lightning, which can occur hundreds of miles away. If the aircraft moves through precipitation, there is a build-up and discharge of energy that produces buzzing in the receiver.

Some pilots say an ADF needle points in the direction of lightning, and this is useful for avoiding thunderstorms. The Stormscope, in fact, is an instrument that operates on that principle. Using a conventional

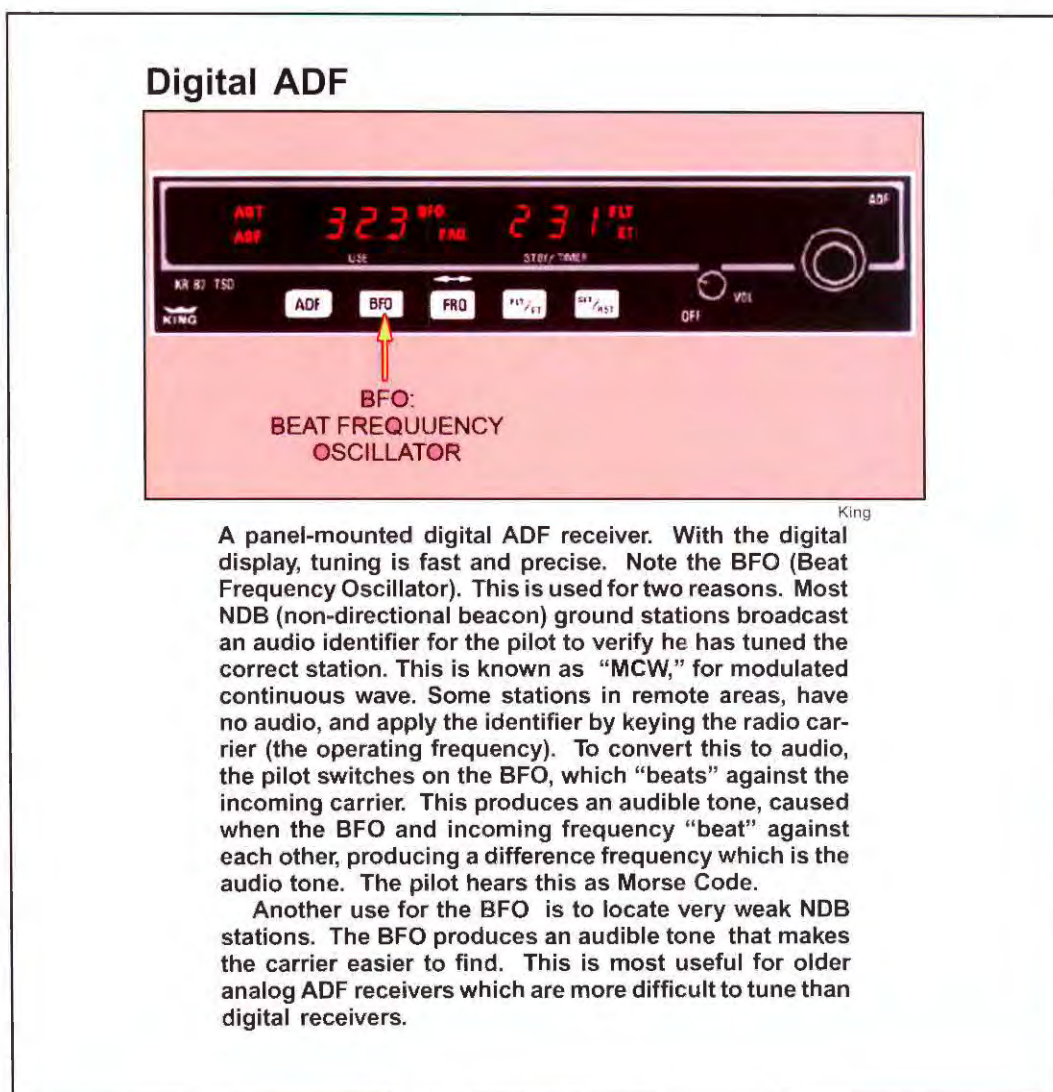

ADF, however, is dangerous because the needle and its drive cannot swing rapidly and change direction, making it a poor indication of storms.

Night Effect. Lower bands “skip” great distances at night through the ionosphere and bring in distant stations. This causes the ADF needle to wander, and accuracy is poor if signals are weak.

Skipping is mostly a problem at night. Radio waves are bent at a shallow angle during the day, when the ionosphere reaches down to a low altitude. The reflected wave in daytime never returns to earth and is lost to space. With the setting sun, the ionosphere thins out (and appears to rise), causing radio waves to reflect back to earth---and cause interference. Thus the term “night effect.”

Coastal Effect. Much of the signal from an NDB station travels by ground wave, hugging the surface of the earth. When the signal crosses between water and land, however, it is slightly bent, which decreases ADF accuracy. “Coastal effect” is most pronounced when the airplane is tracking at a small angle with respect to the coast (as opposed to moving directly from water to shore).

Attitude Error. The bearing to an NDB station is measured with respect to the nose of the airplane. To keep the bearing accurate, the ADF antenna is installed along a fore and aft line of the airplane. This provides good accuracy when the airplane flies straight and level. But during a turn, when wings are banked, the loop antenna is no longer aligned with the direction flight and accuracy suffers. This is not problem so long as the pilot is aware, and doesn’t calculate his bearing to the station while in a turn.

Quadrantal Error. A loop antenna in free space works equally well on signals arriving from any direc-

tion. But on the airplane, loops are affected by engines, wings, fuselage and other masses of metal that lie unequally around the loop. They distort the receiving pattern by “quadrantal error.” To reduce that effect, ADF receivers have a quadrantal error corrector, a device which usually mounts atop the loop antenna. The loop signal first passes through the quadrantal error corrector before proceeding down the transmission line to the receiver.

Loop Swing. A maintenance procedure to reduce quadrantal error is the “loop swing.” The ADF is tuned to a station and bearings recorded as the airplane is rotated through a number of compass degrees, using a magnetic compass as a reference. A chart is made showing each magnetic heading, the bearing shown on the ADF and the error between them. Depending on the type and size of aircraft, this is done on the ground or while in flight. When the data is completed, the inaccuracies are compensated by the quadrantal error corrector, following the manufacturer’s instructions.

ADF Display: EFIS

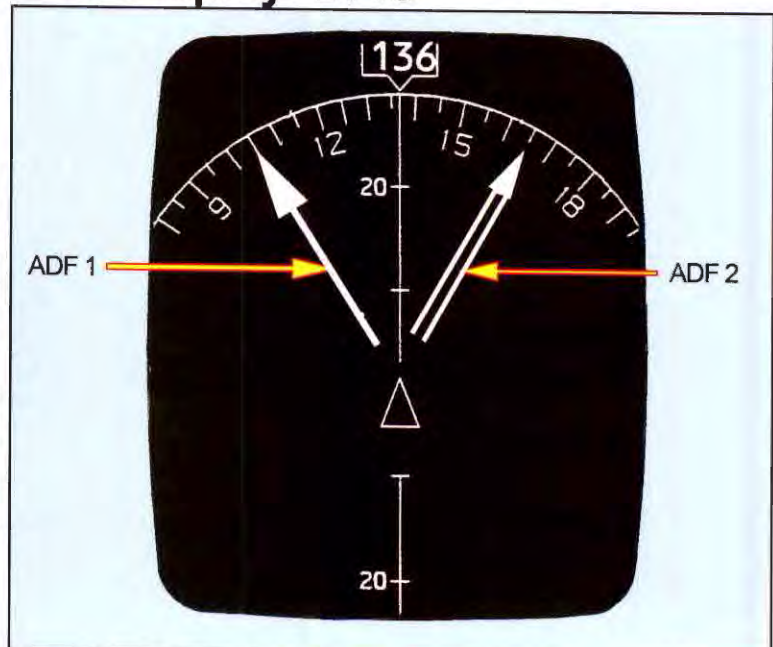

ADF is presented on various instruments. Shown here is the navigation display of an airline-type electronic flight instrument (EFIS) system. The pilot selected two pointers, one for each of the ADF receivers. (VOR information may also be selected for these pointers.)

The two “20” marks along the vertical line show the scale of the display; they indicate 20 miles above and below the airplane symbol (a triangle at the center).

In some aircraft, the ADF is shown on an electromechanical RMI (Radio Magnetic Indicator). The RMI has a 360-degree compass card and two pointers.

Review Questions

Chapter 12 ADF

12.1 On what bands does ADF operate?

12.2 An ADF with a fixed compass card can only indicate _____ bearing to an NDB (non-directional beacon) station.

12.3 When the edge of an ADF loop points toward the station, strongest signal is received. This is known as a _____.

12.4 When the flat side of the loop faces the station, the received signal is weakest. This is known as a _____.

12.5 Which is used by the ADF receiver for determining direction, the peak or null? Why?

12.6 What is the purpose of a sense antenna?

12.7 What is "quadrantal error."

12.8 How can the sense antenna be selected by the pilot?

12.9 How is direction-finding selected?

12.10 What is the function of the switch marked "BFO" or "Tone"?

12.11 What methods reduce interference to ADF reception?

12.12 What type of interference may occur from distant stations?

12.13 What device in an ADF receiver reduces the effect of metal masses on the airplane?

Chapter 13

DME

Distance Measuring Equipment

Nav aids such as VOR, NDB and localizer guide an aircraft along a *course*. But they do not help a pilot fix his position because they don't show *distance* to a station. That information is provided by DME, Distance Measuring Equipment. DME lowers pilot workload, and air regulations require DME for aircraft flying at or above 24,000 feet (Flight Level 240).

The principle of DME is that an airplane sends out an interrogating pulse to a ground station and the station replies. The DME aboard the airplane measures elapsed time to compute distance to the station. Time is multiplied by speed of the signal, which is close to the speed of light. A DME signal takes just over 6 microseconds to travel one nautical mile.

DME is usually part of a military system known as TACAN (tactical air navigation). TACAN provides course guidance (like a VOR) and DME distance for military aircraft. By agreement between military and civil authorities, TACAN stations are located on the same site (and in the same structure) as a VOR station. This benefits civil aircraft; they follow courses from the VOR station, while using the TACAN's DME for distance.

When a VOR houses a TACAN, the facility is known as a Vortac. Another combination---VOR-DME---provides only course and distance functions and not the complete TACAN facility. A DME may also be teamed with a localizer for an instrument approach.

DME Channeling

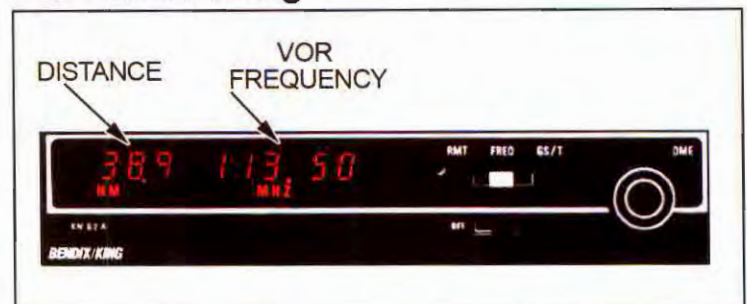

The pilot never sees the DME frequency. When the VOR (113.50 MHz in this example) located with the DME is selected, the DME receiver is channeled to its correct frequency. Note the distance indication shown to within one-tenth mile.

Ground Speed and TTS. Information developed by an airborne DME isn't only distance-to-station. By calculating how rapidly distance is changing, it also displays aircraft ground speed (GS). By knowing ground speed and distance, the DME also reads out TTS, or time to station.

DME ground speed and time-to-station are accurate only when flying directly to or from the station. The airplane, however, may fly in any direction and see the correct distance-to-station. In one instrument approach, the "DME arc," the pilot flies a circle and maintains a fixed DME distance from the station. This

Obtaining DME Distance

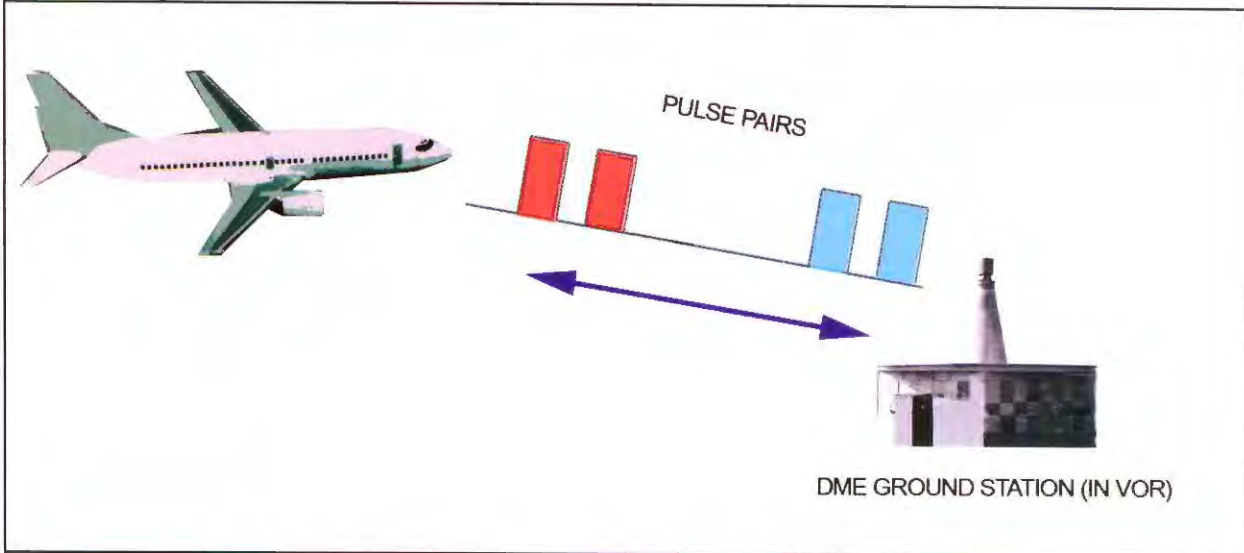

The airplane DME sends pairs of interrogating pulses to the DME ground station. After a delay, the ground station replies by retransmitting the pulses back to the airplane. The round trip time is divided in half and computed as

one-way distance to the station.

Most DME ground facilities are housed in VOR stations, and are part of the military TACAN system.

guides the airplane to a safe position from which to begin the inbound course to the airport.

Slant Range. DME is very accurate, but has an error known as “slant range.” Because signals follow a slanting path from the airplane to the ground, altitude is included in the distance measurement. It is not a factor when the airplane is many miles from the station; at 35 miles at an altitude of 4000 feet, the error is only several dozen feet. When overflying the station, the DME reads the altitude of the airplane.

There are ILS approaches which require DME to provide distance fixes to the airport. In this application, the pilot need not be concerned about slant range

error. He uses DME distances shown on the approach chart, which has been verified by flight inspection aircraft.

Scanning and Agile DME. In recent years, it’s become possible to process more than one DME station at a time. Known as “scanning” DME, the airborne system looks for up to five DME stations within a 300-mile range. When it locks on to three good signals, it continuously fixes the position of the airplane by triangulation. Each station is automatically identified by a 3-letter Morse code ID. The pilot does not have to listen to the code; the dots and dashes are electronically detected and identified.

Random Spacing (“Jitter”) Identifies Each DME Signal

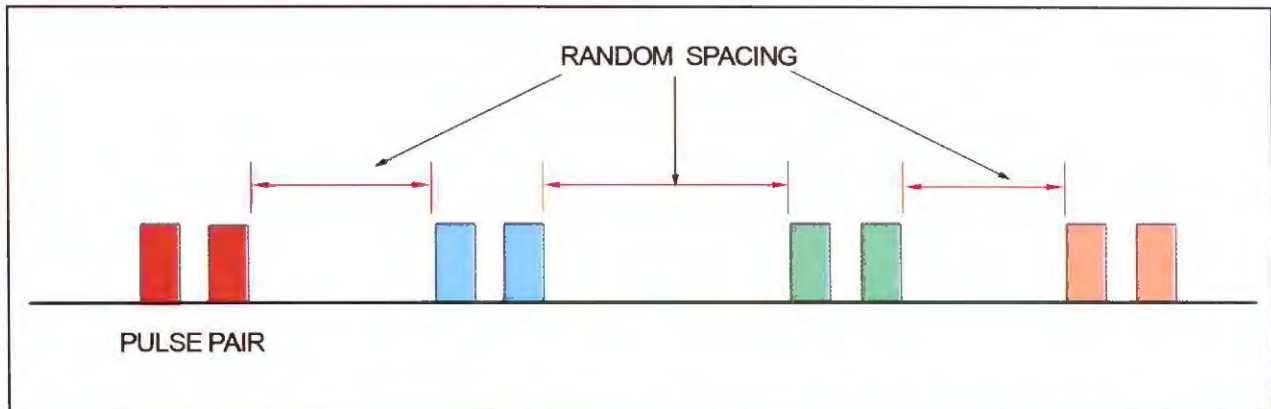

The DME interrogator aboard the aircraft sends out pulse pairs with random spacing (“jitter”). The ground station replies with the identical spacing. This enables

the airborne DME to select its replies from those of other aircraft using the same DME station.

DME Readout on EFIS Display



DME distance appears on the EFIS screen, near the compass rose (horizontal situation indicator). "NAV 1" shows it's reading data from the No. 1 VOR receiver.

Scanning DME is an important navaid in airline operations, especially in Europe where there is a shortage of navigational aids, too few frequencies and congested air traffic. European authorities made a special effort to distribute DME ground stations over a pattern that favors scanning DME. So long as the aircraft processes three DME's simultaneously, it can navigate with high accuracy and require no other navaids.

DME Channeling. A pilot does not directly tune a DME frequency; this is controlled by the VOR receiver. When the pilot chooses a VOR or localizer frequency, the radio automatically channels the correct DME frequency. (This is similar to the pairing of localizer and glideslope frequencies.)

Some DME control-displays do not tune VOR/LOC stations---only DME. However, the pilot still selects a VOR/LOC channel to obtain the DME station paired with the VOR frequency.

DME Jitter and Overload. The DME system has several enhancements to make it work in high traffic environments. In the area of a major airport, dozens of aircraft may be interrogating a single DME ground sta-

tion. Because all aircraft receive all replies, each needs to sort out and identify its own reply. As described in the illustration, each aircraft varies the spacing of its interrogations in a random pattern known as "jitter." When replies arrive, each airplane looks for its unique jitter pattern and locks on to it.

Another problem is overloading the system. This happens when more than about 100 airplanes interrogate one ground station. To protect itself, the station reduces its receiver sensitivity and will not reply to airplanes at the outer edge of its range.

To prevent electrical interference from sending false pulses to a DME, all signals are sent in pulse *pairs*, measured precisely in microseconds. It would be very unusual for lightning strokes or other disturbances to emulate the pulse pair of a DME signal.

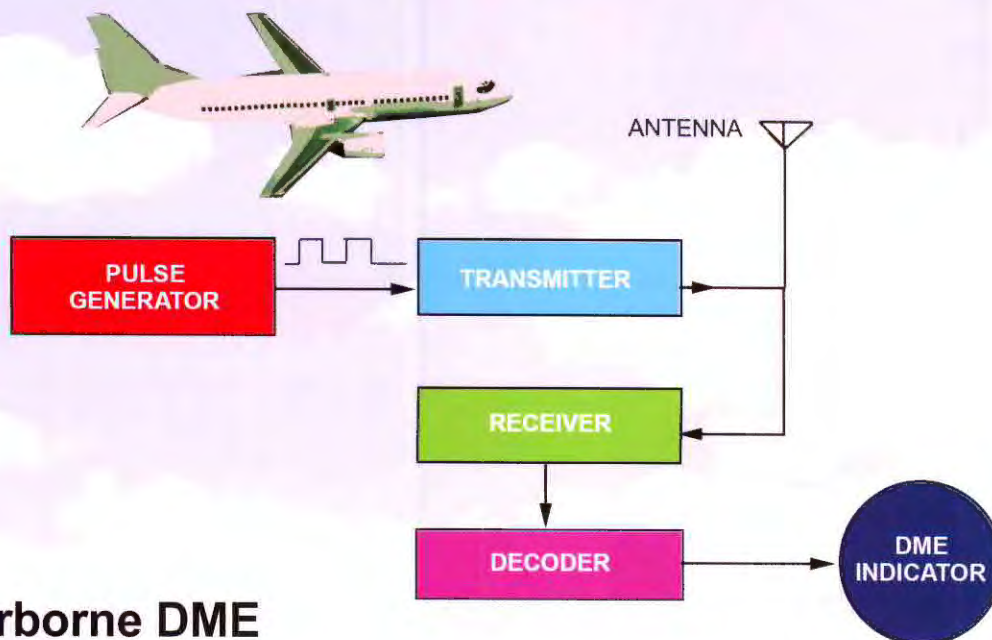

Airborne DME

Pulse Generator

After pulses are produced in the pulse generator, spacing between pulse pairs is varied in random fashion. This imprints the signal with its own identity, in a process known as “jitter.” Each aircraft will have its own jitter pattern.

Transmitter

Pulses modulate the transmitter, then are emitted by the antenna as radio signals. They are DME interrogations on a channel between 978-1213 MHz.

Receiver

After interrogations are received from the ground station, they return to the antenna as replies. Note that both transmitter and receiver are connected to the same antenna. Outgoing and incoming pulses don’t conflict because they are sent and received on different frequencies (63 MHz apart).

Decoder

Replies from the ground station for every airplane in the area are received at the antenna. The decoder in the airplane recognizes its own signal after searching for, and locking on to, its unique jitter pattern.

DME Indicator

After measuring the transit time for a reply from the ground station, the DME computes distance and time to station. Ground speed is determined by the rate of change of the distance signal.

DME Ground Station

The ground station receives, decodes and replies to interrogations from the airplane.

50 Microsecond Time Delay. When the airplane is close to the DME station, outgoing pulses may not allow enough time for replies to arrive from the ground station. To avoid interference, the ground station delays transmitting the reply by 50 microseconds.

Squitter If the ground station receives no interrogations from any aircraft, it “squitters”---that is, freely broadcasts pulses. This “awakens” any aircraft within range; and their DME’s go from “automatic standby” to an interrogating mode.

Audio ID. Every 30 seconds, the ground station sends a Morse code identifier on 1020 Hz. The pilot can identify the DME, or tones are decoded electronically by scanning DME’s.

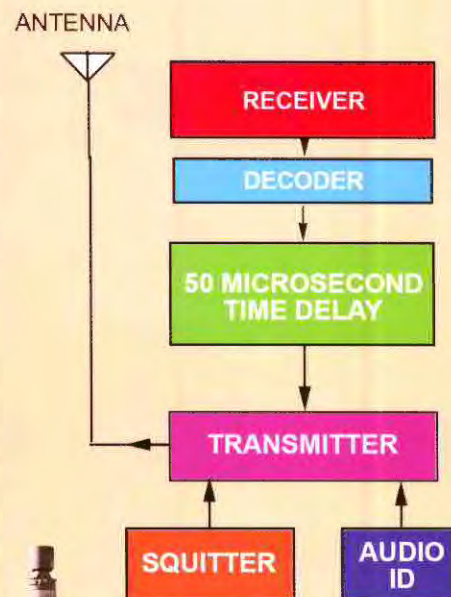

DME Channels: X and Y

VOR Freq	Airborne DME Freq	Type	Pulse Spacing	Ground Reply Freq	Ground Reply Pulse Spacing
117.20 MHz	1143 MHz	X channel	12 microsecond	1206 MHz	12 microseconds
117.25 MHz	1143 MHz	Y channel	36 microseconds	1080 MHz	30 microseconds

When DME began, there were only 100 VOR frequencies spaced .1 MHz apart; for example, 117.20, 117.30, etc. The original DME stations paired with these VOR's are named "X" channels. As shown above, the VOR on 117.20 is paired with a DME frequency of 1143 MHz.

As air traffic increased, the number of VOR's was doubled by "splitting" the channels; 117.20, 117.25, 117.30, etc. This doubled the VOR channels from 100 to 200. The added frequencies created the new DME "Y" channels. There are two differences between X and Y channels:

Pulse Spacing

Note in the table above, 117.20 (an X channel) sends out interrogations on 1143 MHz, with a pulse pair spacing of 12 microseconds.

The interrogations for the Y channel, paired with 117.25, has a pulse spacing of 36 microseconds, three times longer.

Next, notice the different pulse spacing for the reply from the ground station; for the X channel it is 12 microseconds, and 36 microsecond for the Y channels.

Reply Frequencies

The DME system requires two separate radio frequency

carriers so interrogations and replies do not interfere with each other. For this to work, their frequencies must be widely separated (so the transmitter does not overload the receiver). This is done by separating the radio carriers by 63 MHz.

Consider the X channel example above:

Reply frequency (ground station):	1206 MHz
Interrogation (from airplane)	1143
Difference	63 MHz

Next, the Y channel:

Interrogation	1143 MHz
Reply	1080
Difference	63 MHz

Regardless of whether the airplane is on an X or Y channel, the interrogation always goes out on 1143 MHz. However, for an X channel, the reply comes back 63 MHz *higher* than the interrogation. For the Y channel, the reply is 63 MHz *below* the interrogation.

By these techniques of changing the space between pulse pairs and a different position for the reply frequency, the system doubles the amount of DME stations and allows tight spacing of the channels.

One DME for Two VOR Receivers

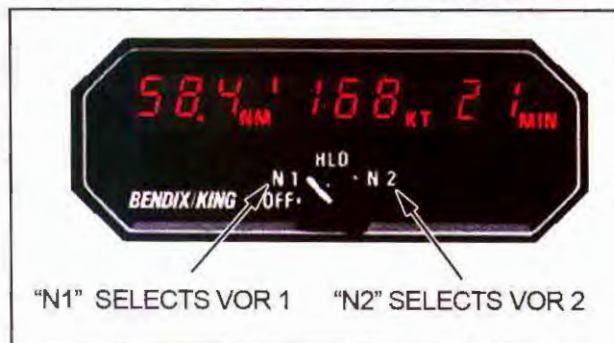

A single DME display can connect to two VOR receivers. The pilot selects either "N (nav)1" or "N2." Note that "1" appears near the top, above "NM," to indicate VOR 1 is the source of the DME.

Review Questions

Chapter 13 DME

13.1 An airborne DME sends out a pulse known as an _____.

13.2 DME is a component of a military system known as _____.

13.3 A DME station is located as part of a _____ ground station. Together they are known as a _____.

13.4 In addition to distance-to-station, an airborne DME computes _____ and _____.

13.5 A distance error in DME is called _____.

13.7 All aircraft interrogating the same DME ground station are on the same frequency. How does an aircraft identify its replies from all others?

13.8 How is a DME station tuned in?

13.9. What happens when more than about 100 aircraft interrogate the same DME ground station?

13.10 Why does the DME ground station delay its reply by 50 microseconds?

13.11 Does the DME station transmit an ID?

Chapter 14

Transponder

A transponder (“transmitter-responder”) receives a signal from a ground station (an “interrogation”) and automatically transmits a reply. Transponders were developed for the military at a time when radar could locate airplanes but couldn’t tell the friendlies from the enemy. The reply of a transponder provides that information; the airplane’s ID, altitude and other data.

When first introduced, transponders were called “IFF,” for Identification, Friend Or Foe. The term is still used, but mostly by the military. In civil aviation, it is in a system called SSR, for “Secondary Surveillance Radar.” It is *secondary* because primary radar simply sends a signal from the ground that reflects from the metal surface of the airplane and receives an echo called a “skin return.”

In the airline world the transponder is labeled “ATC,” referring to Air Traffic Control.

Squawk. When a pilot is instructed by ATC to set his transponder to a code (say, 1234), the controller says:

“Squawk 1234.”

The pilot selects the code on the control panel that causes his airplane’s ID to appear on the radarscope. Sometimes a controller may need to verify the ID, in which case he asks the pilot to “Ident.” The pilot responds by pressing an ID button on the transponder, which causes his target on the ground radar to “bloom,” creating a circle of light that clearly indicates the location of the airplane.

The word “squawk” goes back to World War II when the British, to keep their new transponder secret,

Control-Display Unit

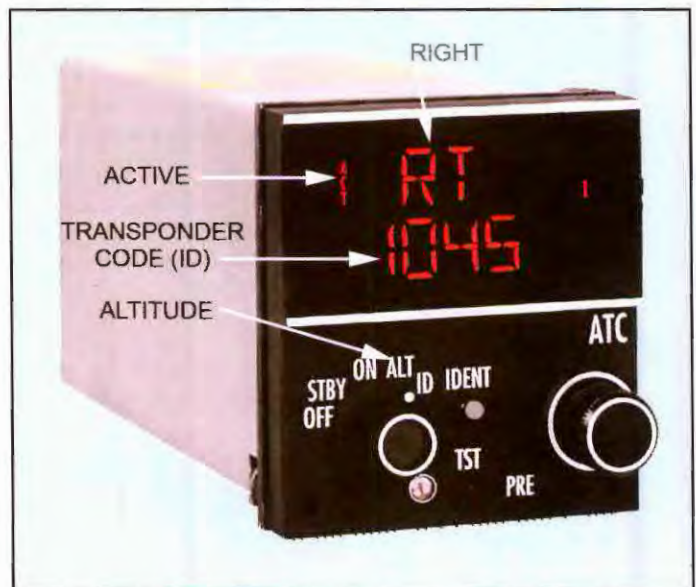

Transponder control head. The transponder is “squawking” an identification code of “1045,” which is the Mode A function. Also transmitted is altitude, the Mode C function. The ident button is pressed only when requested by the controller. The standby (STBY) position keeps the transponder hot, but prevents replies. This reduces clutter on the radar screen while the airplane taxis on the ground at an airport. As the airplane lifts off, the pilot turns the knob to Mode C (which activates ID and altitude replies).

Note “ATC” at the upper right. This term is used for the transponder in large and airline aircraft.

Transponder Interrogator

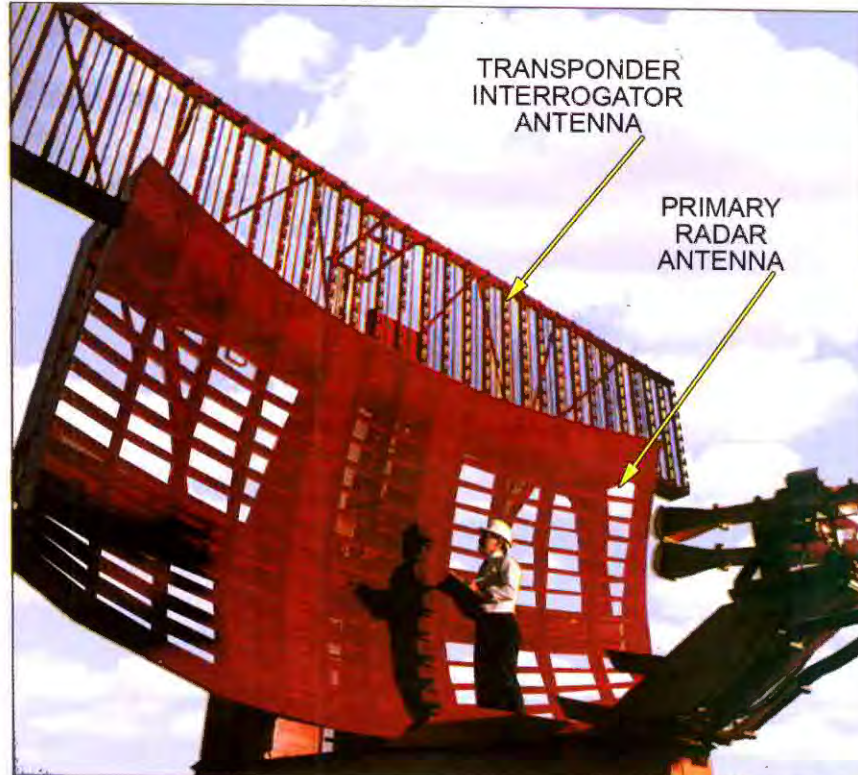

(Westinghouse)

The aircraft transponder sends to, and receives from, the top section of a surveillance radar known as a “beacon interrogator.”

The larger antenna below it is the older primary radar, which sends out a pulse and picks up the signal reflected from the skin of the aircraft. Because skin returns are weak, difficult to see and carry no information other than the range and bearing of the aircraft, they are used only as a back-up.

The beacon interrogator on top, on the other hand, picks up a signal that's strengthened thousands of times by the aircraft transponder. Besides a bright display, the image on the radar screen carries data such as aircraft ID, transponder code and ground speed.

The surveillance radar shown above is an ASR---airport surveillance radar---that covers up to about 60 miles from the airport. To the pilot, this is “approach control” or “Tracon” (terminal radar approach control).

During cross-country flight, airplanes receive longer range coverage from “en route” radars of larger size and power.

called it “Parrot.” It survives to this day in the military; when a (British) controller wants a pilot to turn off his transponder, he says, “Strangle your parrot!”

The word “parrot” also explains why controllers today ask the pilot to “Squawk” a transponder code.

Grand Canyon. Transponders came into widespread use after a mid-air collision between two airliners over the Grand Canyon in 1956. A DC-7 and a Constellation requested permission from ATC to fly off course so passengers could enjoy the view. Flying outside controlled airspace (on a sunny day) the air-

planes collided with the loss of 128 lives. The disaster began an overhaul of the ATC system (and created the FAA). With an ability to put strong targets and flight data on the radar screen, transponders became a key component in the air traffic system.

Two Systems: ATCRBS and Mode S

ATCRBS. The transponder improved air traffic control for a half-century, operating under the name, ATCRBS, for Air Traffic Control Radiobeacon System.” But it began showing its age as the aircraft popu-

Panel-Mount Transponder (Mode S)

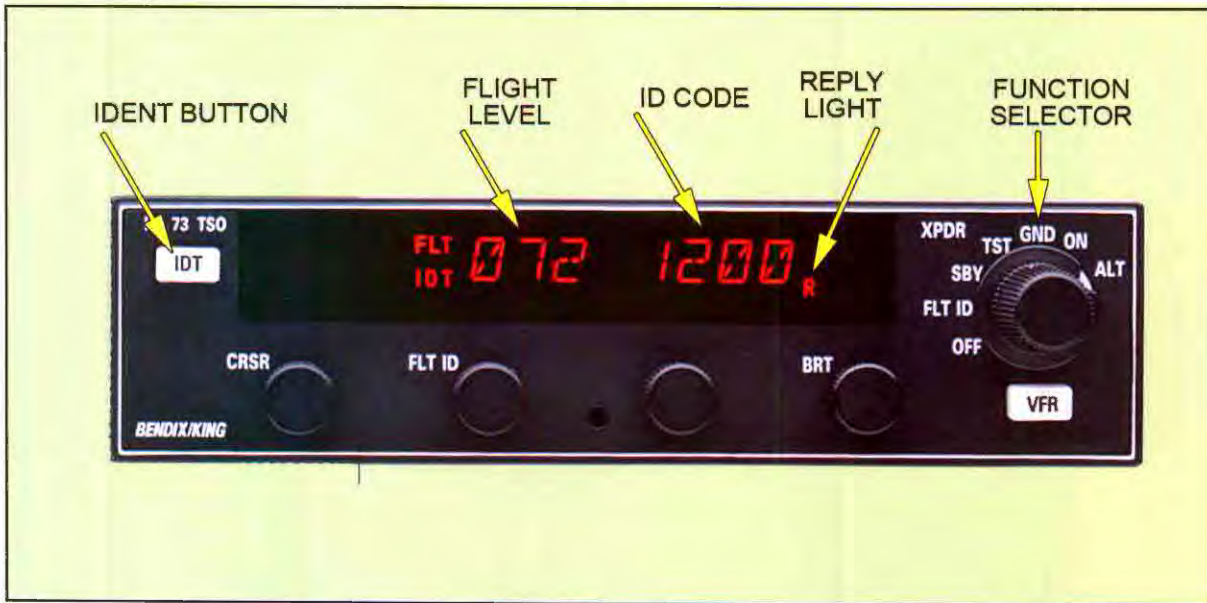

A Mode S transponder for General Aviation, the Bendix/King KT-73. Its controls and displays include:

IDENT BUTTON. The pilot presses the button when air traffic control requests “Ident.” The reply light (R) illuminates for several seconds while the reply transmits.

The same Reply Light also blinks when the transponder answers interrogations from the ground.

FLIGHT LEVEL. The altitude of the airplane, as reported by the transponder in hundreds of feet. Thus, “072” on the display is 7200 feet (add two zeroes).

ID CODE. The squawk code assigned by ATC under the older transponder system (ATCRBS). It is dialed in by four knobs along the bottom of the panel.

FUNCTION SELECTOR. This turns the transponder on, displays the flight ID code and tests all lighted segments of the display. The Ground position disables most transponder functions because they are not needed on the ground. A large number of airplanes on the airport surface would clutter radar displays. The pilot switches, shortly after take-off to Alt (altitude) to resume normal transponder operation. The Alt position reports ID and altitude.

The “VFR” button at the bottom right automatically sets the transponder to 1200. This code is selected when the airplane is not on an instrument flight plan and is flying under visual flight rules (VFR).

lation grew and more airplanes operated out of fewer airports.

There are several limitations on ATCRBS. First, it wastes space in the radio spectrum. When the radar antenna on the ground sweeps around, it interrogates all airplanes within range—and all airplanes reply. The controller cannot obtain a reply only from the airplane it needs to contact.

Also, when radar sends a beam, it sweeps across the airplane, making 20 or more interrogations in one pass. Only one interrogation and reply are required; extra replies limit the capacity of the system.

Another shortcoming is “synchronous garble,” which is two replies happening at the same time. Let’s say two airplanes are on the same line north of the radar site; one at 20 miles, the other at 30 miles. Because they are both struck by the same radar interrogation, they reply nearly at the same time. The two replies move along the same line back to the radar antenna and

interfere with each other. To the controller, the targets appear confused or “garbled.”

Another limit for the ATCRBS transponder is in the collision avoidance system (TCAS). As described in the chapter on TCAS, two aircraft approaching each other must fly an escape maneuver that keeps them apart; for example, to avoid a collision, one flies up, the other flies down. That maneuver must be coordinated by the transponder, but ATCRBS cannot provide this function.

Mode S. The answer to these problems came as a completely new transponder known as Mode S (S for Select). It means “selective addressing,” which enables a controller to request a specific airplane to reply, not the whole fleet. This greatly reduces the number of unnecessary signals filling the air.

A requirement of Mode S is that it does not rapidly obsolete the ATCRBS transponder. The two must be able to exist side by side during a long transition

Transponder

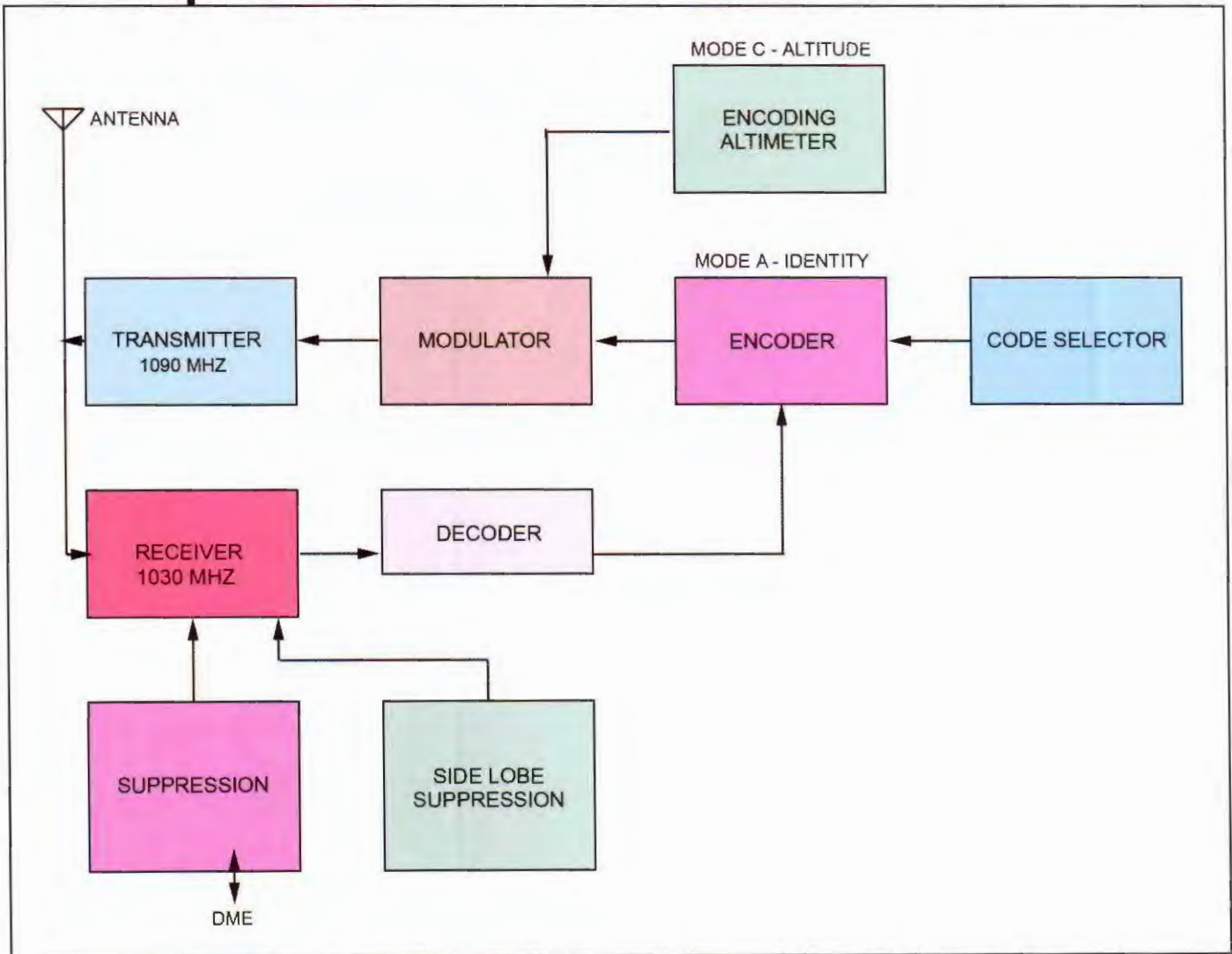

The transponder is a transmitter-receiver with these major building blocks:

RECEIVER

Interrogations from the ground station are picked up by the antenna on a frequency of 1030 MHz. The pulses are applied to the decoder.

DECODER

Measuring incoming pulses, the decoder identifies the type of interrogation. If they are recognized they are passed on to the encoder.

ENCODER

The encoder creates the pulse train which contains the reply.

ENCODING ALTIMETER

After converting barometric pressure (based on 29.92 inches of mercury) to electrical signals, the encoding altimeter sends altitude information to the encoder for the Mode C reply.

CODE SELECTOR

The pilot dials in the 4-digit transponder code, which is sent to the encoder.

MODULATOR

Pulses that form the reply are amplified in the modulator and applied to the TRANSMITTER for transmission on 1090 MHz.

SIDE LOBE SUPPRESSION

The radar signal from the ground contains a main lobe and several side lobes. If the transponder replies to a side lobe, the radar operator will see the airplane at the wrong position. The side lobe suppression circuit prevents the transponder from replying if it senses reception of a side lobe.

SUPPRESSION

There is a chance that other transmitters aboard the airplane might interfere with the transponder. This usually caused by the DME, which operates close in frequency. To avoid interaction, the transponder receiver is suppressed when the DME transmits. The DME receiver is also suppressed when the transponder is transmitting.

Transponder Control-Display (Airline)



A Mode S transponder installed in the B-777 and numerous other large aircraft. Because it works so closely with TCAS (anti-collision system), several TCAS controls appear with the transponder knobs. For example, in the circle marked "1," is the mileage range for TCAS surveillance. In "2" are types of collision warnings selected for display.

ACSS

Line Replaceable Unit (LRU)

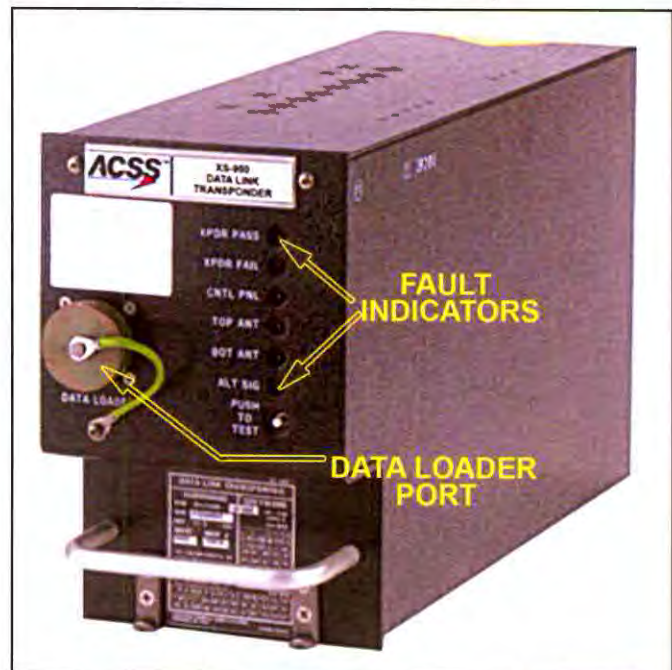

The LRU controlled by the transponder panel unit. Troubleshooting is helped by fault indicator lights that monitor the transponder, antennas and control panel.

When software upgrades occur, they are loaded through the data loader port.

ACSS

period. The Mode S system, therefore, is "backwardly compatible" in that ATCRBS and Mode S transponders work within all air traffic control systems. Surveillance radars for both types are now in service.

The FAA had issued an end date for the manufacture of ATCRBS transponders, expecting Mode S to gradually take over as old transponders wore out. Announcing the end of ATCRBS, however, raised protests from the General Aviation community. The Mode S transponder was more expensive and didn't offer any advantages to owners of light aircraft. The only buyers of Mode S were airlines because it was a requirement for the anti-collision system (described in the chapter on TCAS).

But a new development changed opposition to Mode S. Sales of the new transponder surged in General Aviation after the year 2000 because valuable new pilot services were added to Mode S. The FAA introduced the Traffic Information Service (TIS) which uplinks, through the Mode S transponder, images of air traffic throughout the U.S. It provides an option for light aircraft to have an anti-collision system at relatively low cost.

Aircraft Address. For ATC to single out one airplane each Mode S aircraft has its own "Aircraft Address." It's 24 bits long and obtained through the aviation authority of each country. The address is programmed into the transponder during installation, along with the aircraft's maximum speed.

A caution about addresses was issued by Eurocontrol, the air traffic agency for Europe. It reported instances of errors by technicians in entering the address during installation, or when changing the country of registration. Eurocontrol says that such errors can disable an Airborne Collision Avoidance System (ACAS), which is the same as TCAS in the U.S.

Mode A Interrogation

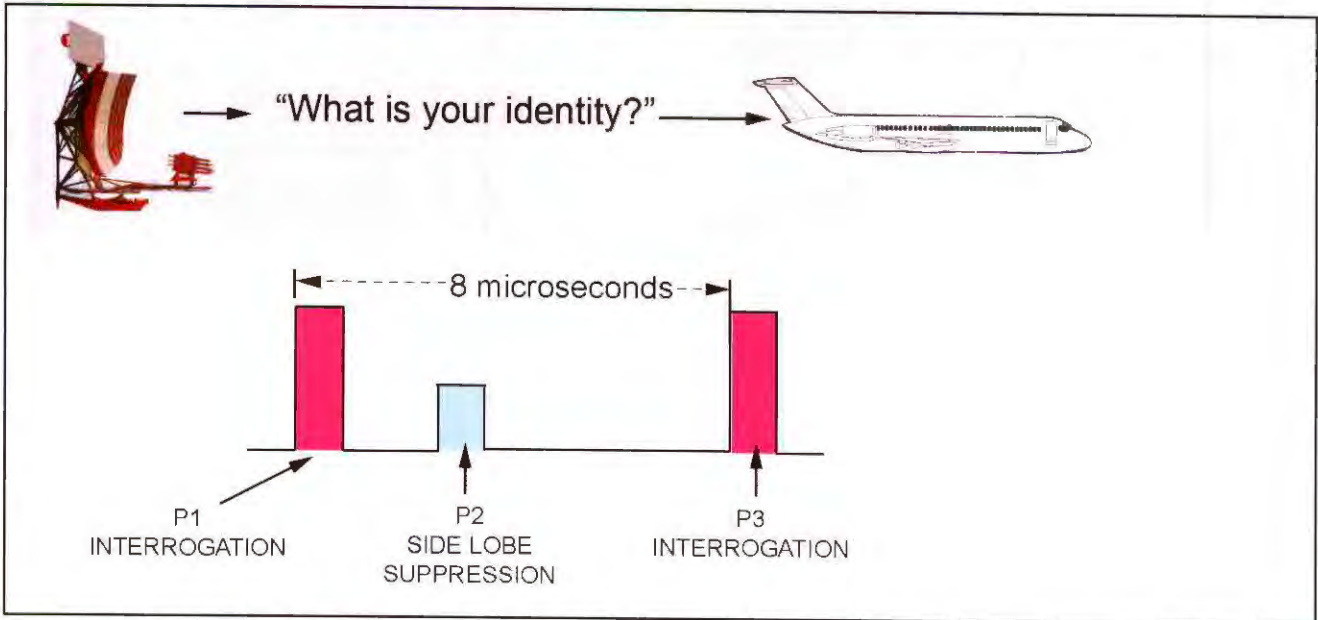

Surveillance radar on the ground sends out an interrogating pulse to learn the aircraft ID (the code selected by the pilot on the transponder). The upgoing radar signal consists of three pulses, as shown above; P1, P2 and P3. Consider P1 and P3, which tell the airplane this is a Mode A interrogation. It's done by the 8 microsecond time period between the two pulses. On measuring this interval, the transponder recognizes it as a Mode A interrogation and sends a reply containing the aircraft ID. P2 overcomes a problem with the radar (and any other directional antenna known as "sidelobes." These are un-

avoidable loops of radio energy that lie on either side of the main beam of the radar antenna. The problem is that an aircraft transponder may reply to a sidelobe, which places the airplane in the wrong location on the radar screen. Pulse P2 eliminates the problem. If P2 remains *below* P1 in strength, it means the transponder is receiving the main beam of the radar. This triggers a reply. However, if P2 is *higher* than P1, it means a sidelobe is being received; now the transponder will not reply. When the airplane is correctly illuminated by the main beam, P1 remains higher than P2 and the transponder replies.

Mode C Interrogation

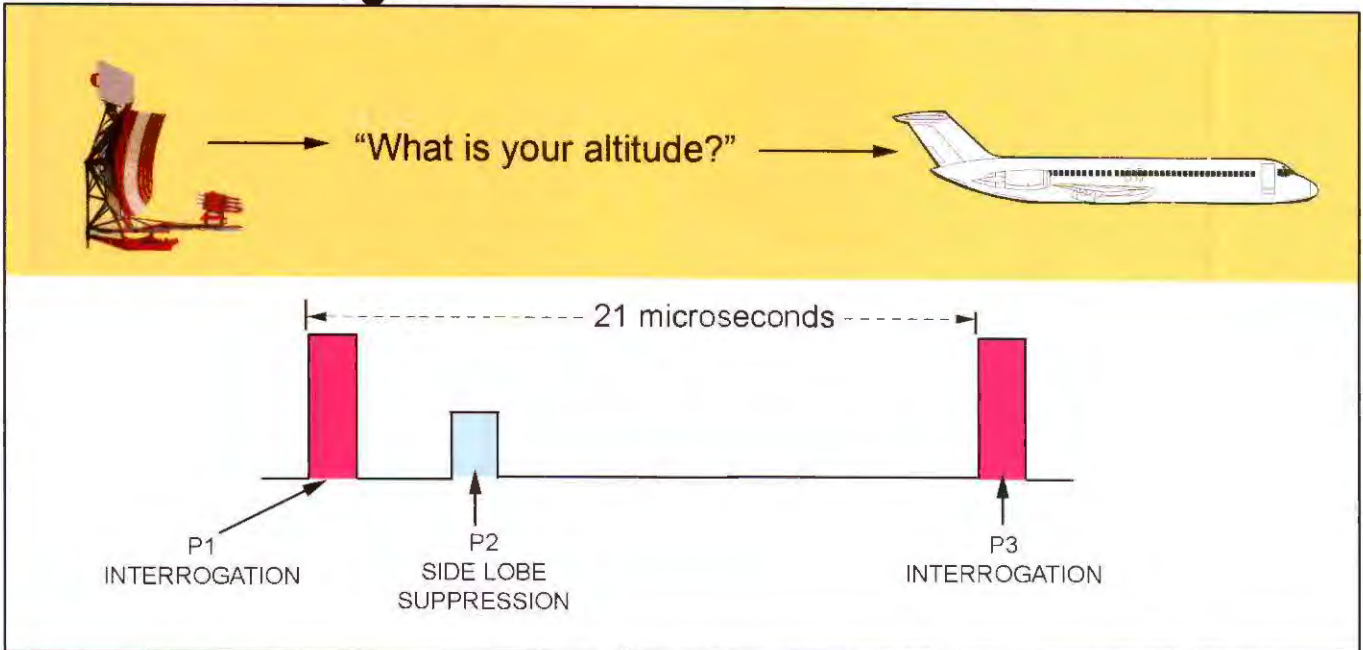

Next, the surveillance radar sends out a set of pulses to learn the aircraft's altitude (Mode C). The aircraft transponder recognizes it by the spacing between P1 and P3, which is now 21 microseconds long (more than 2 1/2 times longer than for a Mode A interrogation). The purpose of

P2 is the same as already described for Mode C. As the ATC radar antenna makes one full rotation, it transmits a Mode A interrogation, followed by a Mode C interrogation on the next rotation.

Altitude Reporting; Mode C

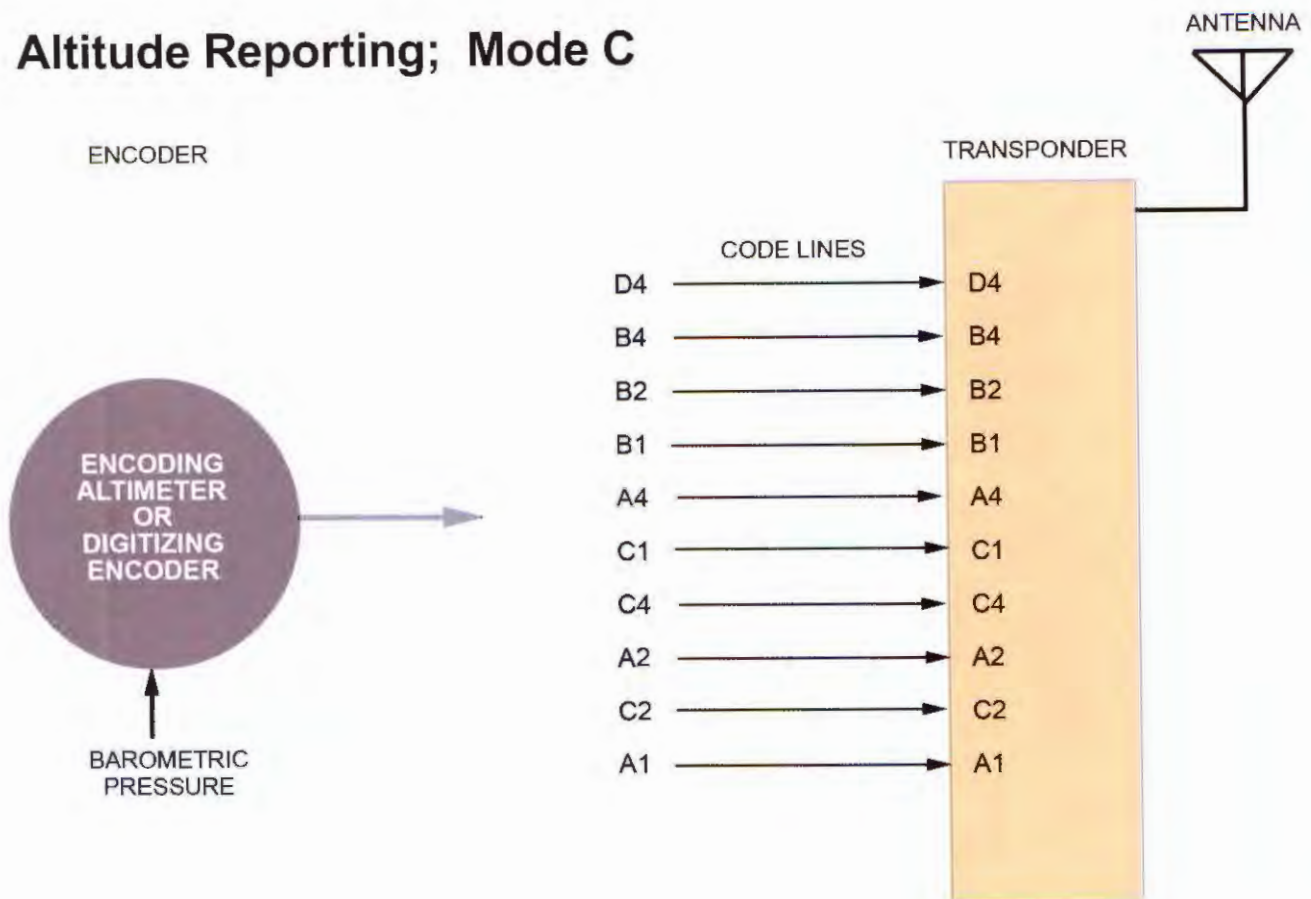

The transponder reports an airplane's altitude when replying to a Mode C ground interrogation. It begins by measuring air pressure surrounding the airplane, often done with an aneroid sensor, a capsule which is mechanically squeezed by pressure. This movement is converted to an electrical signal representing altitude and is connected to the transponder.

There are two possible locations for an aneroid sensor. When built into the altimeter, the instrument is called an "encoding altimeter." When mounted separately, it is known as a "blind encoder" (because it has no dial and is hidden from view).

Altimeters have a knob for setting local air pressure because weather is always changing---as high and low pressure systems move across the country. During a flight the pilot resets the altimeter to maintain an accurate reading above sea level.

An important feature of transponder operation is that the aneroid sensor is *never* adjusted by the pilot. It is permanently fixed to 29.92 inches of mercury, standard sea level pressure, and is known as "pressure altitude." In the metric system it is 1013 millibars. A pilot may make many adjustments to correct his altimeter reading in different pressure areas, but this does not change the pressure sensor. The sensor is preset at the factory for 29.92

and recalibrated every two years when the transponder is recertified by a technician.

There are several reasons for reporting altitude based on a standard pressure. One is that pilot error could transmit the wrong altitude to air traffic control. It could also send incorrect information to TCAS (anti-collision) systems aboard nearby aircraft, which also interrogate the transponder for altitude.

If all transponders report altitude based on a pressure of 29.92, the altitude sent to ground radar will contain the error caused by changes in the air mass. This is corrected by the air traffic facility when it receives the Mode C reply; it corrects to 29.92 against local air pressure at sea level.

As seen in the illustration above, the encoder sends information via code lines to the transponder. The letters represent pulse positions on the transponder reply signal, which form binary words that encode altitude every 100 feet. Known as the "Gray" or "Gilham" code, it can transmit altitudes from -1000 feet to 126,700 feet.

During most of aviation's history, altitude has been based on instruments driven by air pressure. In the future, this function will be increasingly provided by GPS or other satnav system. GPS can already fix the vertical position of an airplane to within a few centimeters, with no reference to air pressure.

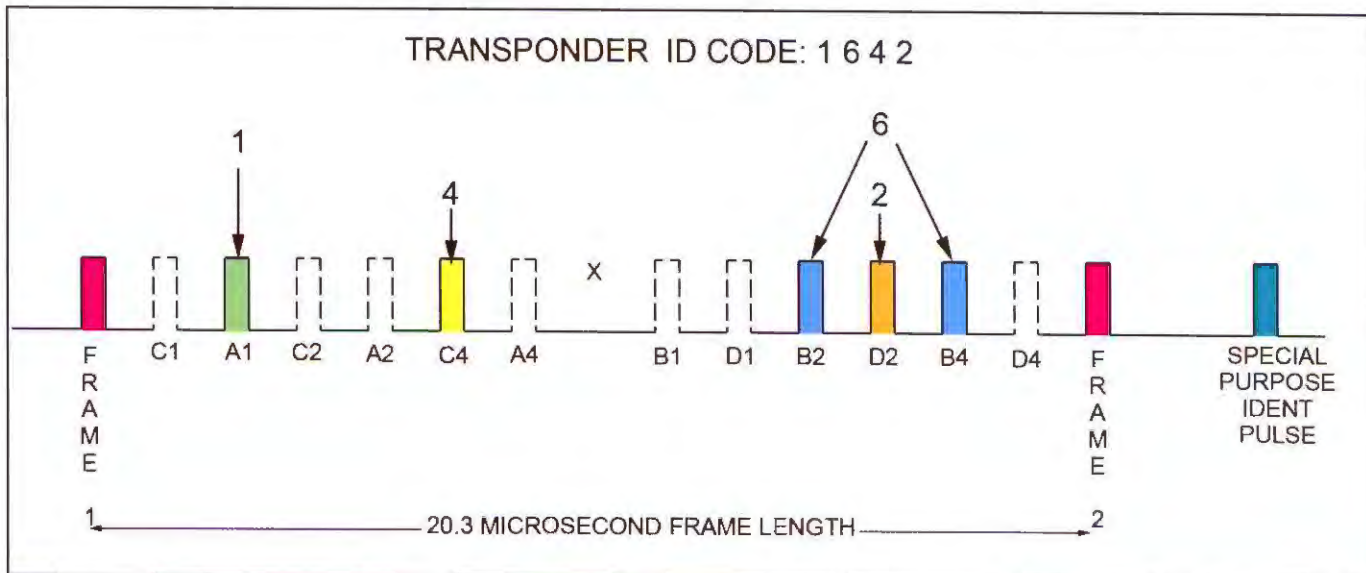

The transponder sends its ID by selecting various pulse positions (time slots) spread over a "frame." Shown above are positions selected for an ID of "1642". Although the coding uses digital signals (on-off pulses), it was developed over 50 years ago and has only 4096 codes. This will eventually be replaced by the Mode S transponder, with far more sophisticated coding and greater capacity.

At the far right is the Special Purpose Identification Pulse. In normal air traffic operations, the controller easily identifies each aircraft by examining its "data block," an area on the radar screen next to the target showing

aircraft ID, altitude and ground speed. Occasionally, however, the controller wants to verify that he is looking at the correct target and asks the pilot to "Ident." When the pilot presses the Ident button, it sends the Special Purpose Identification Pulse. The target on the radar "blooms" in a circle of light, positively identifying the aircraft from all other targets. At the same time, the pilot sees the reply light on his transponder remain on for about 15 seconds.

The Ident button should never be pressed unless requested by the controller.



Transponder ID selected by the pilot is 1200, the code for VFR (visual flight rules) in the U.S. It is 7000 in Europe. When flying under IFR (instrument flight rules) the code is assigned by air traffic control. The transponder shown is the Garmin GTX-327.

When selecting a transponder code, avoid dialing through the following, which are reserved for special use:

- 7500 Hijack
- 7600 Loss of communications
- 7700 Emergency
- 7777 Military interceptor operations (never use)
- 0000 Military (usually cannot be entered on civil transponders)

Mode S: Interrogations and Replies

1. Mode S - ATCRBS All Call

In a mix of traffic carrying ATCRBS and Mode S transponders, the radar sends out an "all call" interrogation. All transponders reply with ID and altitude. Each Mode S transponder replies with its own 24-bit address. As each aircraft enters the radar coverage area, it responds to the "all call" interrogation.

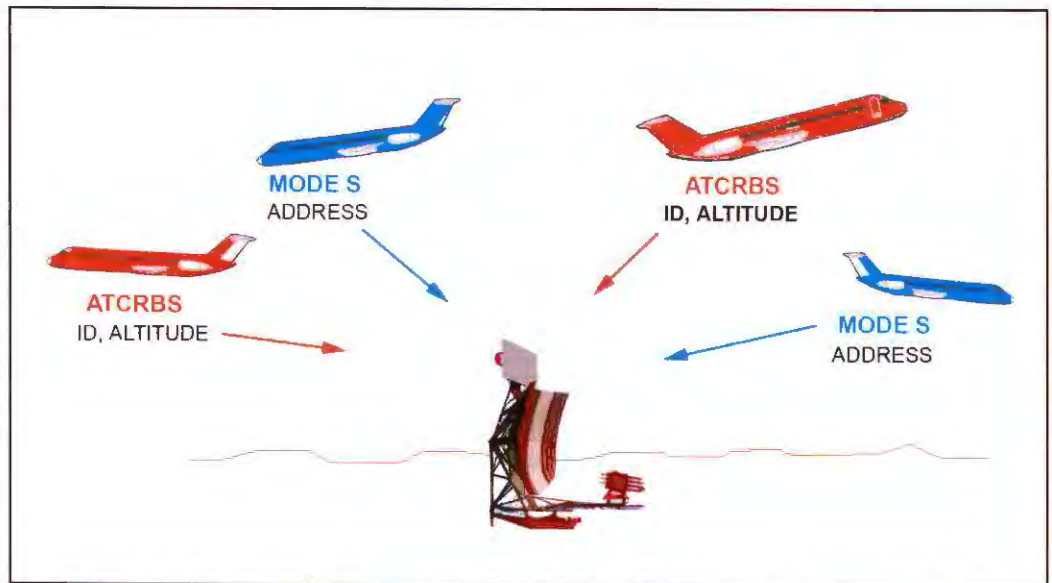

2. Mode S Discrete All Call

All Mode S transponders reply with their 24-bit address. ATCRBS aircraft do not reply.

When the radar gets a Mode S address, it locks out the transponder from replying to further all call interrogations. Until the airplane leaves the area, it replies only when radar interrogates it selectively. The airplane, however, is still tracked on the radar scope but with many fewer interrogations.

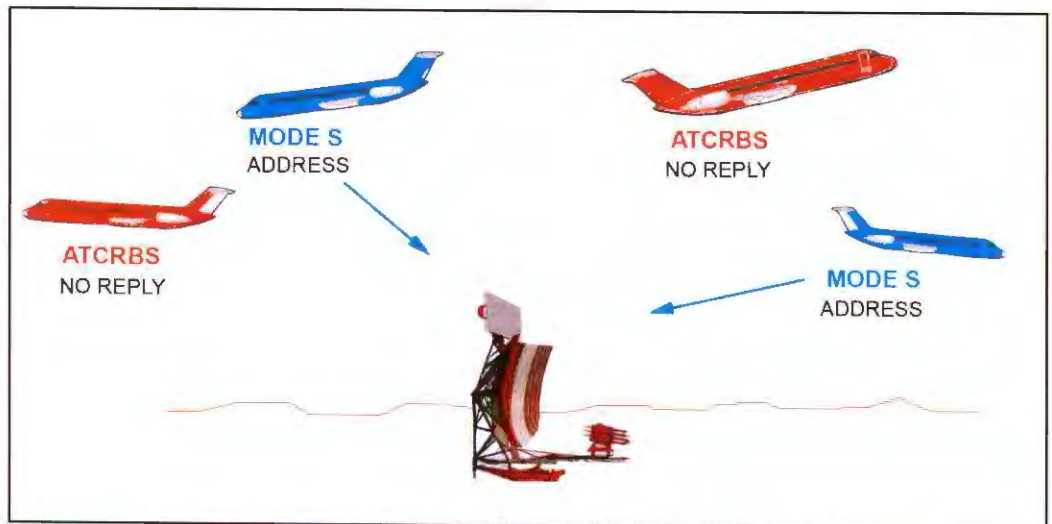

3. Mode S Selective Address

If a controller needs to communicate with only one aircraft, it transmits the Mode S address. Only that airplane replies.

This greatly increases capacity of the air traffic system. It also eliminates "synchronous garble"--- where two airplanes reply to the same interrogation. This can happen when airplanes are on the same line to the radar antenna or are closely spaced.

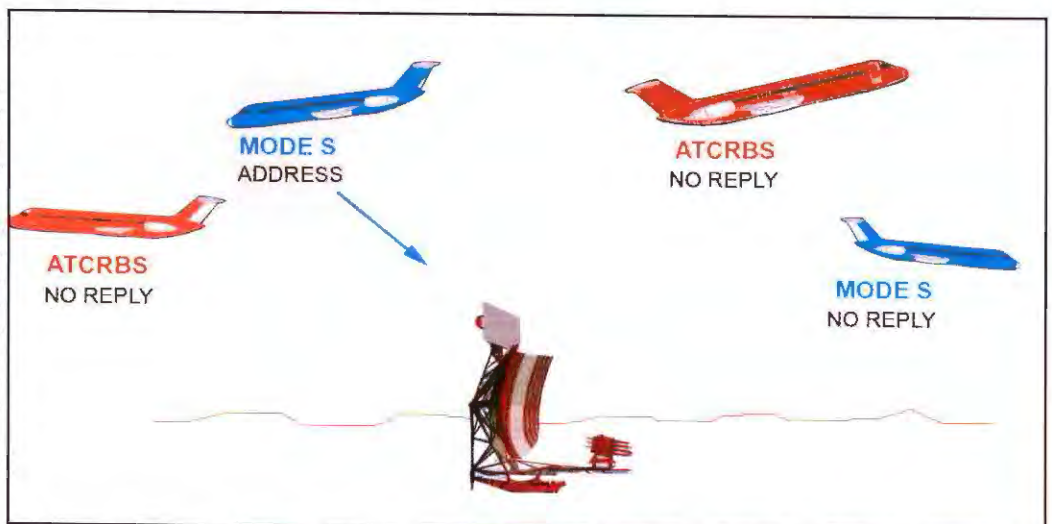

Review Questions

Chapter 14 Transponder

- 14.1 A transponder receives an _____ from a ground station and transmits a _____.
- 14.2 The transponder operates in a system known as “SSR”. What do the letters mean?
- 14.3 How is an airline transponder labelled?
- 14.4 How many digits are in a transponder ID code?
- 14.5. What are two advantages of transponder signals over primary radar, or “skin” return”?
14. 6 The first secondary surveillance system is known as _____. The improved system is called _____.
- 14.7 What is the main benefit of Mode S?
- 14.8 What transponder information is carried by Mode A? Mode C?
- 14.9 When a radar interrogator wants every aircraft in range to reply (ATCRBS and Mode S), it transmits _____.

Chapter 15

Radar Altimeter

The radar altimeter is required for aircraft operating during the very low ceilings and visibilities of Category II and III instrument approaches. The conventional barometric altimeter can only read altitude above sea level and needs frequent readjustment as weather brings changes in pressure. Under the best of conditions, a conventional altimeter is usually accurate to 60 or 70 feet. That's not adequate when landing an airplane in near-zero visibility, where errors of more than about six feet may cause a hard landing or worse. Radar altimeters, on the other hand, give altitude with errors as small as two feet. Although the fully "blind" landing is not regularly flown, most widebody transports are equipped for "autoland"---which can fly the airplane through descent, decrab (nose straight), flare, touchdown and rollout. The radar altimeter is essential for such operations so close to the ground.

A radar altimeter makes it possible by measuring *absolute* altitude. Instead of deriving altitude from air pressure, it transmits a radio wave, listens for the echo from the ground, then computes altitude. The result is a reading in feet "AGL", above ground level. The computation is done by knowing the speed of the radio wave (speed of light) and amount of time that

Radar Altimeter Display



Panel-mounted radar altimeter indicator. The transmitter-receiver is located remotely. The LED display is indicating ALT AGL (altitude above ground level) of 50 feet. The pilot preselected decision height (DH) to 200 feet, a typical ceiling minimum for a Category I instrument landing. When the airplane descends below DH, the pilot hears an audible warning (1 kHz tone).

"GEAR" also illuminates and sounds the tone when the airplane descends below 100 feet and the landing gear is not down and locked.

Alerts can also give warnings every 100 feet, starting at 800 feet, to help the pilot find the ground.

When the TEST button is depressed, the display should read a 40-foot altitude and sound an audible alert.

Radar Altimeter Antennas



Two independent radar altimeters are installed for some instrument operations requiring separate antenna installations.

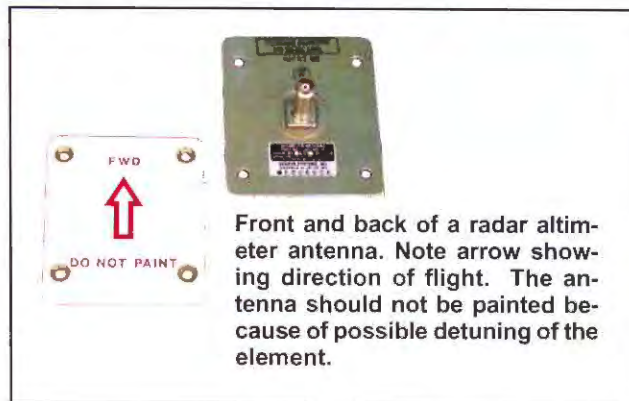

Front and back of a radar altimeter antenna. Note arrow showing direction of flight. The antenna should not be painted because of possible detuning of the element.

elapses for the wave to travel from airplane to ground and back. This is similar to radar, which sends out a pulse and measures the returning echo, but most radar altimeters do not use pulses. They operate on the principle of FMCW; for “frequency modulation continuous wave”.

The radar altimeter is sometimes called by its older name, “radio altimeter.” On the instrument panel it is often abbreviated as “RAD ALT.”

The main components are a transmitter and receiver operating on a center frequency of 4300 MHz. The transmitter sends out low power of about 350 milliwatts. The receiver and transmitter each has its own antenna.

As shown in the illustration, the cycle begins with a transmitted wave. Although it is basically on 4300 MHz, it continuously shifts in frequency (thus the name, frequency modulation). Let’s say when the wave hits the ground, it is slightly *higher* than the resting frequency of 4300 MHz. When the echo reflects back to the airplane the round trip takes a certain amount of time. When the echo reaches the airplane, the passage of time has allowed the transmitter to shift to an even higher frequency.

Now the receiver has the information it needs; two frequencies that mark the beginning and end of the signal’s round trip. Because the receiver knows how long it takes for the transmitter to shift frequency, it uses this value (time) in a calculation: travel speed of the signal multiplied by time equals distance. The rate of travel is constant; radio waves move like light (6.18 microseconds per mile). Because the signal travels down and up, the answer is divided in half before it is displayed to the pilot as altitude.

Radar altimeters are used only at low altitude, usually from -20 feet to 2500 feet. They are intended mostly for “altitude awareness” when the airplane is low to the ground in low visibility, and as part of the automatic flight control system. When the airplane cruises at altitude well above obstacles, or during a landing in good visibility, the regular barometric altimeter is sufficiently accurate.

The key functions of the radar altimeter are:

Decision Height (DH). During an instrument approach, a pilot makes a decision to: continue to land, abort the approach, go around and try again, or fly to better weather at an alternate airport. The radar altim-

Radar Altimeter: Operation

1. The radar altimeter produces a radio frequency carrier with a resting frequency of 4300 MHz. As it transmits, the frequency shifts 50 times per second off the resting frequency. The carrier increases to about 4350 MHz and down to 4250 MHz. This is shown at points A (Low Freq) and B (High Freq). From this process, the system derives its name; FMCW, for Frequency Modulation Continuous Wave.

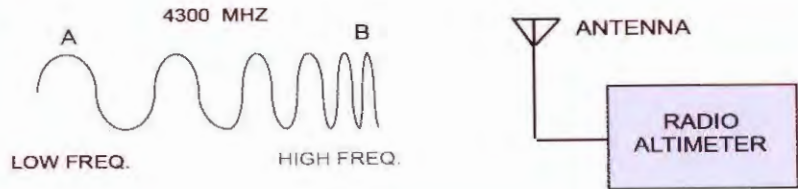

2. The airplane is shown over a point on the ground. At this instant, the radar altimeter is transmitting the carrier at its lowest frequency (A). The signal travels to the ground and is reflected back to the airplane at the same frequency (A).

The returning signal reaches the airplane after an interval of time, the number of microseconds it takes for the round trip.

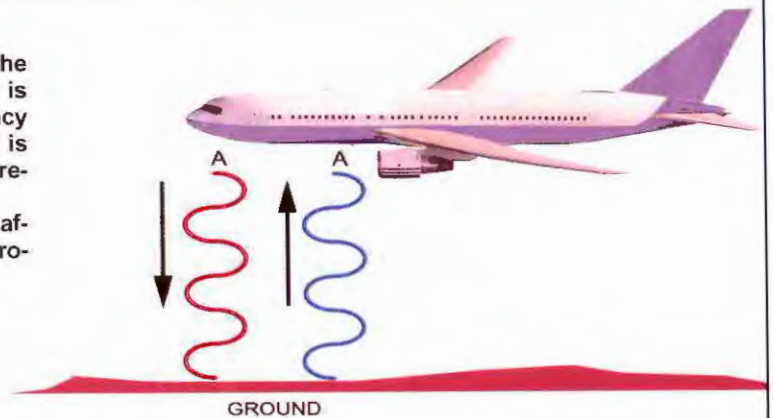

3. Because time has passed, the radar altimeter is now transmitting on a higher frequency (B). The system has two frequencies to process; A, the reflection from the ground, and B, the higher frequency. Three quantities are now known: the amount the carrier frequency is changing, elapsed time for the signal to make the round

trip and the speed of the signal (speed of light). They are computed as altitude above ground in feet.

The shift in the carrier during frequency modulation is 50 times per second (50 Hz), enabling the radar altimeter to rapidly update. This is critical when an aircraft is descending through the last few hundred feet above ground.

eter is required for performing a Category II or III instrument approach, where decision height is 50 feet or lower.

Altitude Trips. In this function, the radar altimeter sounds a warning as the airplane descends through preselected altitudes. It gives the pilot a clear indication of when Decision Height will occur.

Gear Warning. If the radar altimeter senses the aircraft is close to touchdown, and wheels are not down and locked, it sounds a warning.

Other Applications. Radar altimeters work with other avionics systems aboard the airplane. A ground proximity warning system needs several inputs, including the radar altimeter, for determining whether to warn the pilot of a ground collision. It also operates the “rising runway,” a symbol that appears at the bottom of the attitude director display for a Category II or IIIA instrument landing. It helps the pilot keep the airplane aligned with the runway during touchdown and roll-out. Other outputs of the radar altimeter go to the autothrottle, flight control system and flight data recorder.



Terra

A round analog display indicating 160 feet above ground level.

Although not a requirement for helicopter flight, radar altimeters are useful to pilots making a vertical descent in darkness. The pilot sets Decision Height at around 100 feet and, upon reaching that altitude, switches on a floodlight to see the landing spot below.

Review Questions

Chapter 15 Radar Altimeter

- 15.1 What is the main application of the radar altimeter?
- 15.2 The radar altimeter measures _____ altitude.
- 15.3 The altitude indicated by a radar altimeter is AGL. What do the letters mean?
- 15.4 What are three major components of a radar altimeter?
- 15.5 What is the resting carrier frequency of a radar altimeter?
- 15.6 What categories of approach require a radar altimeter?
- 15.7 The carrier of a radar altimeter is frequency modulated, meaning it moves _____ and _____ in frequency.
- 15.8 One factor in measuring radio altitude is the difference in frequency between the _____ and _____ wave.
- 15.9 When are radar altimeters useful in helicopter operations?

Ch 16

GPS/Satnav



Rockwell

Satnav---satellite navigation---will replace nearly every other form of radionavigation. It meets or exceeds the accuracy, reliability and global coverage of land-based systems. Satnav is also supported by world aviation agencies to eliminate the high cost of servicing thousands of VOR, ILS, NDB and other ground stations.

The benefits of satnav will multiply as GPS, a U.S. system, is joined in coming years by Europe's Galileo. To avoid obsoleting the huge avionics investment in old aircraft, however, today's land-based stations will continue to operate well into the 21st Century.

Satnav. In the 1980's, the captain of a trans-atlantic flight between Sweden and New York walked back to the passenger cabin. He was approached by a man who said, "Captain, I believe we are 10 miles off course."

A typical GPS satellite weighs nearly 1800 pounds and is powered by a combination of solar panels (in sunlight) and rechargeable batteries (in the dark). Because precise time is essential, each satellite carries four atomic clocks that keep time accurate to one second in 80,000 years. The overall width of the satellite, including solar panels, is about 19 feet.

The satellite continuously broadcasts the GPS signal through 12 rod-like (helical) antennas, shown in the illustration as pointing "To Earth."

The captain looked at him and replied, "You're probably right." He had noticed the man holding a portable GPS. The airliner was navigating by the most advanced system known; the ring laser gyro. (Three of them, in fact, for redundancy.) The laser gyro is guaranteed not to exceed an error of 1 mile per hour--meaning that after a 4-hour flight across an ocean, the airplane would be no more than 4 miles off either side of its assigned track. That passenger's pocket

GPS Constellation: "Space Segment"

Number of satellites in orbit.....24
(21 active and 3 spares)
Height above earth.....11,000 n miles
Orbital planes.....6
Time to complete one orbit.....12 hours
(circles the earth twice a day)

There are six paths, or "planes," with up to five satellites each. To an observer on earth, they appear to rise at the horizon, cross the equator, then descend below the opposite horizon. Over most of the earth, at least five or more satellites are available for navigation at any time.

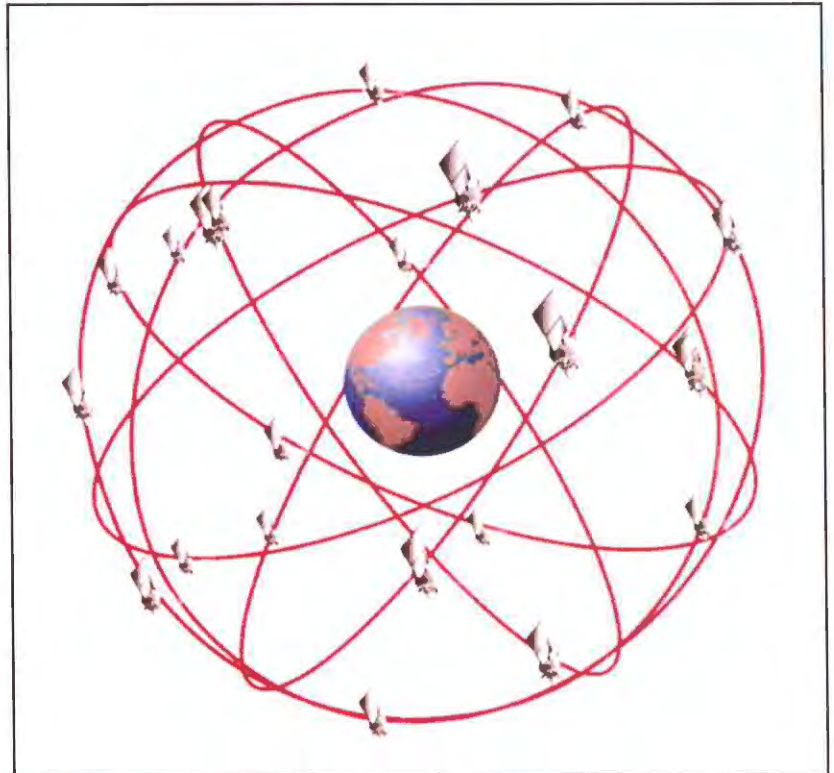

GPS not only knew the aircraft position within less than 100 meters, but held that accuracy throughout the trip (updating once per second).

Radionavigation for nearly 100 years sent out signals to be detected by an airborne receiver. But by the 1960's the microcomputer introduced digital signal processing. Instead of transmitting simple tones or timing pulses, a satellite could encode large amounts of data and broadcast it over the earth's surface. This data could then control the accuracy and performance of even the most inexpensive GPS receiver.

This places the costliest components---like precision timing generators---aboard the satellites, not in the receiver. Each GPS satellite carries at least two atomic clocks, which measure time by the motion of atomic particles of the elements rubidium or cesium. When the Galileo satellites appear, they will add yet another technology; the "maser," a cousin to the laser. In the maser, radio waves are driven to a high state of energy, then allowed to fall to a lower level. During the fallback, they produce oscillations which are extremely accurate timing references.

The GPS clock aboard the airplane, one the other hand, is a simple quartz type, like the one in wrist-

Launch Vehicle



GPS satellite is launched by Delta II rocket at Cape Kennedy. Although satellites are usually rated for a life of 7.5 years, many have operated 11 years.

watches. Its accuracy is controlled by precision data streaming down from the satellite.

Clocks are the key to fixing the position of the airplane. They measure the time for a signal to leave the satellite and arrive at the airborne receiver. By multiplying travel time by speed of the signal (which is the speed of light), the answer is the number of miles to the satellite. By solving that for several satellites, the receiver fixes the position of the airplane.

As shown in the illustrations, a satellite transmits its position and health, plus the position and health of *every* other satellite in the GPS constellation. Data is received continuously and stored in the receiver database. This enables the receiver to select a satellite and perform a "correlation". The receiver tries to locate and match the signal pattern transmitted by the satellite with patterns stored in its database. Once a match is discovered, the receiver can measure the travel time of the signal. The receiver knows when the signal left the satellite because the satellite transmitted a "navigation" message which tells when the signal was broadcast and the satellite's location in orbit. The receiver then compares the time with its own internal ("local")

clock time. The difference between them is the amount of time the signal travelled. The receiver doesn't require an expensive atomic clock because its time is kept accurate by reference to the satellite clock.

The ability to correlate signals between satellite and receiver provides another benefit. Satellites carry a limited payload and generate radio carriers of very low power. So low, in fact, that when the signal arrives at the receiver it is below the "noise" (natural and man-made). In most radio communications, it is nearly impossible to pick out a signal when it is below the noise level. The GPS receiver, however, has stored in its database an exact pattern of the signal and can narrow its response to that coding. By acting so selectively, the receiver rejects much of the noise.

Early GPS receivers acquired only one satellite at a time, which is too slow for aviation. Today's GPS receivers are often "12-channel parallel," meaning they can process up to 12 satellites simultaneously. If a GPS receiver is taken thousands of miles from its home base with the power turned off, it "finds itself" a minute or two after being turned on. With a 12-channel parallel system, the receiver performs a rapid "sky search".

GPS Frequencies

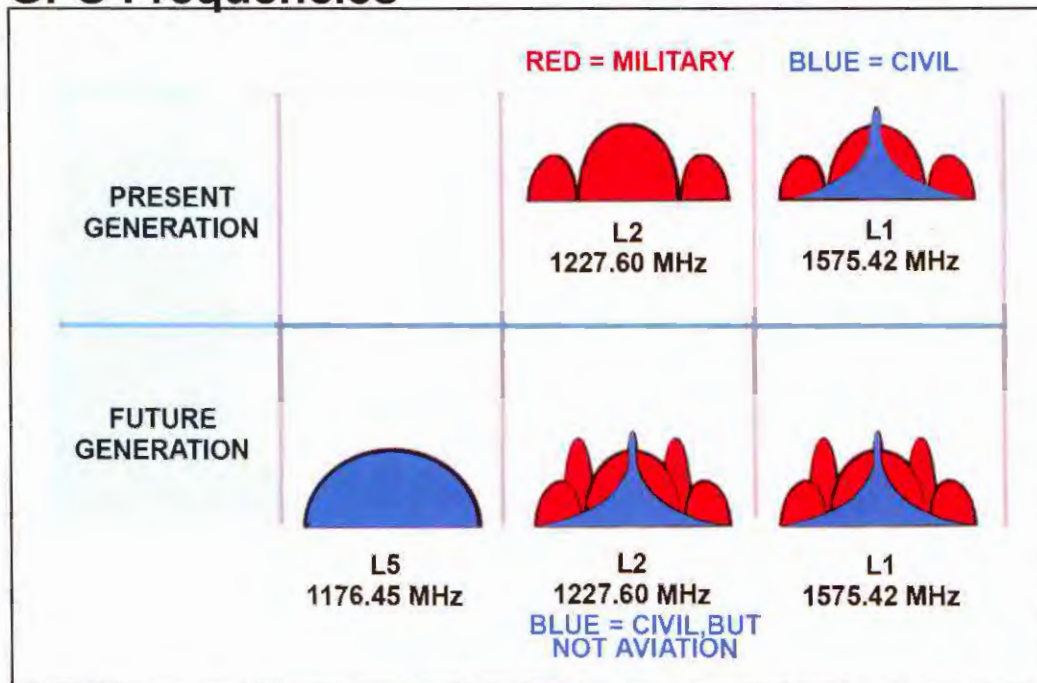

In early GPS generations, civil aviation used L1 and shared it with the military. L2 was exclusively for the military who used it with L1 to achieve high accuracy. In the coming generation, civil users get a second frequency (L5) for increased accuracy. Error will drop to 3 to 10 meters. A major advantage of two frequencies is the ability of the receiver to measure and correct propagation error caused by differences in signal speed through the unstable ionosphere.

Satnav Terms and Service

Some major terms and acronyms to describe satnav systems:

GNSS: Global Navigation Satellite System. The international term to describe navigation based on satellites. When GNSS describes a precision instrument approach, it is called **GLS** (the LS meaning Landing System).

SA: Selective Availability. Because GPS began as a system for the U.S. Dept. of Defense, the highest accuracy was reserved for the military. The signal available to civil users was degraded by "SA," which limited receivers to about 100-meter accuracy.

In the year 2000, Selective Availability was turned off and accuracy improved by about five times.

SPS: Standard Positioning Service. This service is intended for civil users and is located on L1, one of two existing GPS channels. More channels will be added in the future.

Panel-Mount GPS Receiver



A GPS receiver used in IFR (instrument flight rules), like this Bendix-King KLN-94, must update its navigation database regularly. This can be done in two ways. A database card is inserted into the slot, or the dataloader jack connected to a PC. Updates may be obtained over the Internet.

Airplane Measures Time to Compute Distance to Satellite

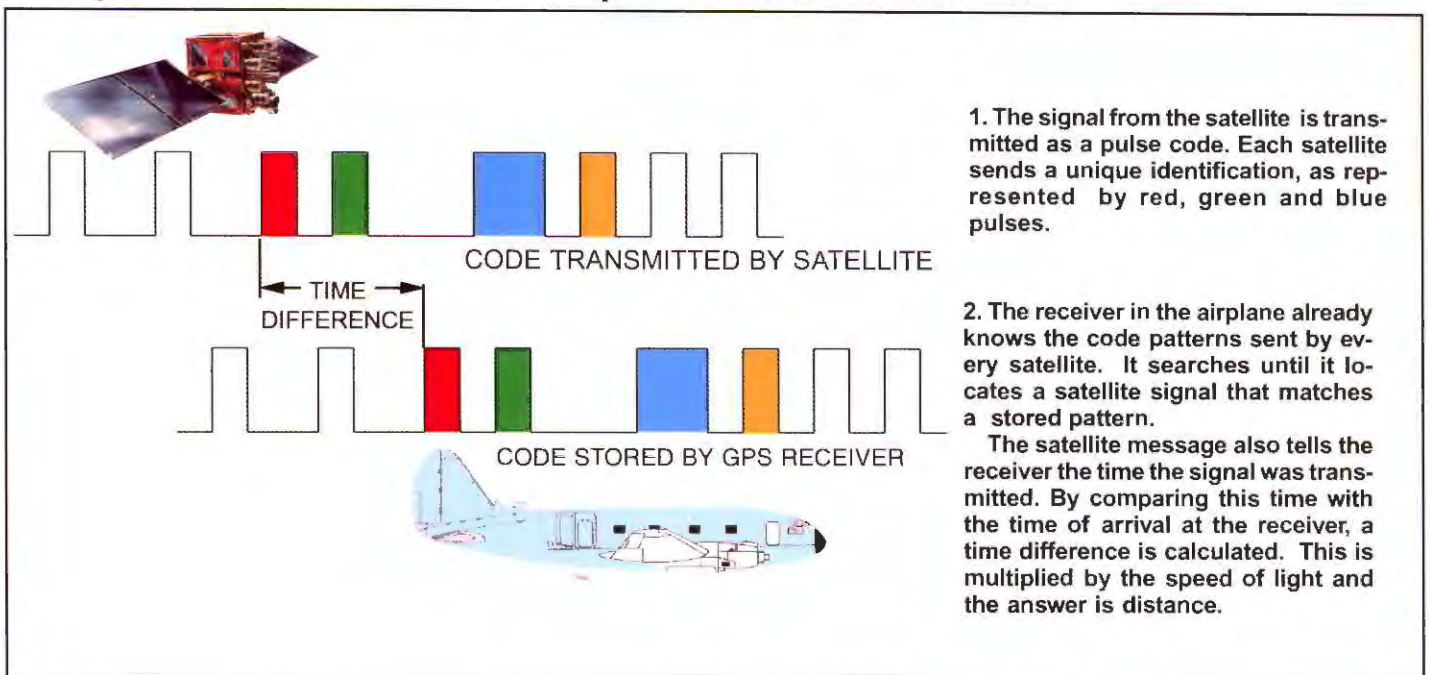

Finding Position

When only one signal is received, the airplane may be located anywhere on the surface of a sphere (or “bubble”), with the satellite (SV1) at its center. After receiving a second satellite (SV2) the spheres intersect and narrow the position. With SV3, the position is further refined. It takes a fourth satellite to obtain latitude, longitude and altitude, which is a 3-dimensional fix.

Receiving a fourth satellite is required for correcting the clock in the GPS receiver. That enables a low-cost clock to keep sufficiently accurate time for the distance-solving problem.

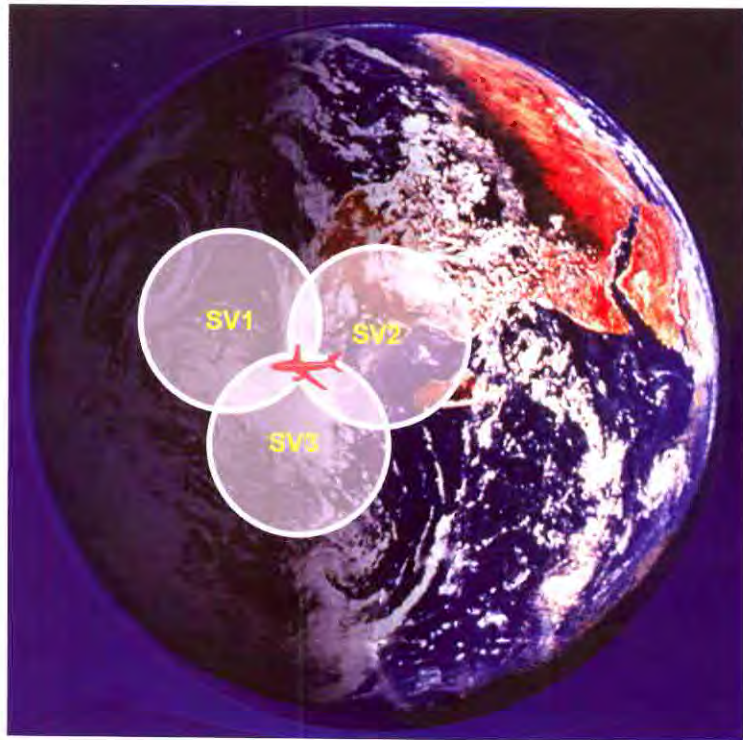

C/A Code: Coarse/Acquisition Code. This is the code transmitted on the civil channel, L1. It is “coarse” because it has the least accuracy.

PPS: Precise Positioning Service. Provides the greatest accuracy for military users and operates on the two existing GPS channels, L1 (shared with civil) and L2 (military only). It uses the “P Code,” which is encrypted and available only to qualified users.

Propagation Corrections. The advantage of two channels, L1 and L2, is reducing propagation error. As satellite signals move toward earth, they pass through the ionosphere, which lies from about 60 miles to 200 miles above earth. Although radio signals move at close to the speed of light, higher frequencies move faster through the ionosphere, which introduces error. By measuring different GPS frequencies, L1 and L2, the receiver computes the “propagation” error and removes it.

The military removes the error because it is able to receive both L1 and L2. However, future satellites will add a civil code to L2, enabling any civil receiver to solve the error. Later, civil aviation will receive a third civil frequency, L5.

PRN Code

Each satellite transmits a unique identity known as a “pseudorandom” code. The term “pseudo” usually means “false” but in GPS it means “uncorrected”. It is called “random” because the GPS signal resembles random noise.

The atomic clocks aboard satellites are extremely precise, however, they do drift in time. The error is measured by ground stations, but this is not used to correct satellite time. Atomic clocks are not easily reset while in orbit. It is more practical to develop a time correction factor based on the error and send it to the GPS receiver. The receiver stores the correction factors for all satellites in orbit and applies them while developing a position fix. For maximum timing accuracy, at least four satellites should be received.

Position-fixing. Determining aircraft position is similar to “triangulation.” The receiver draws lines of position from several satellites, and locates the airplane where they intersect. One way to visualize this is to imagine each satellite surrounded by a large bubble. When the airplane measures distance from a satellite, the receiver places the airplane somewhere on the *surface* of the bubble. For example, if the range is 15,000 miles, the airplane may be anywhere on the bubble and still be at 15,000 miles.

Next, assume the receiver measures 18,000 miles to another satellite, placing the airplane on the surface of the bubble surrounding that satellite. As more satellites are measured, intersections among the bubbles grow smaller until the receiver has a position accurate to several feet. It is not unusual to receive eight or more satellites at once.

The Satellite Signal

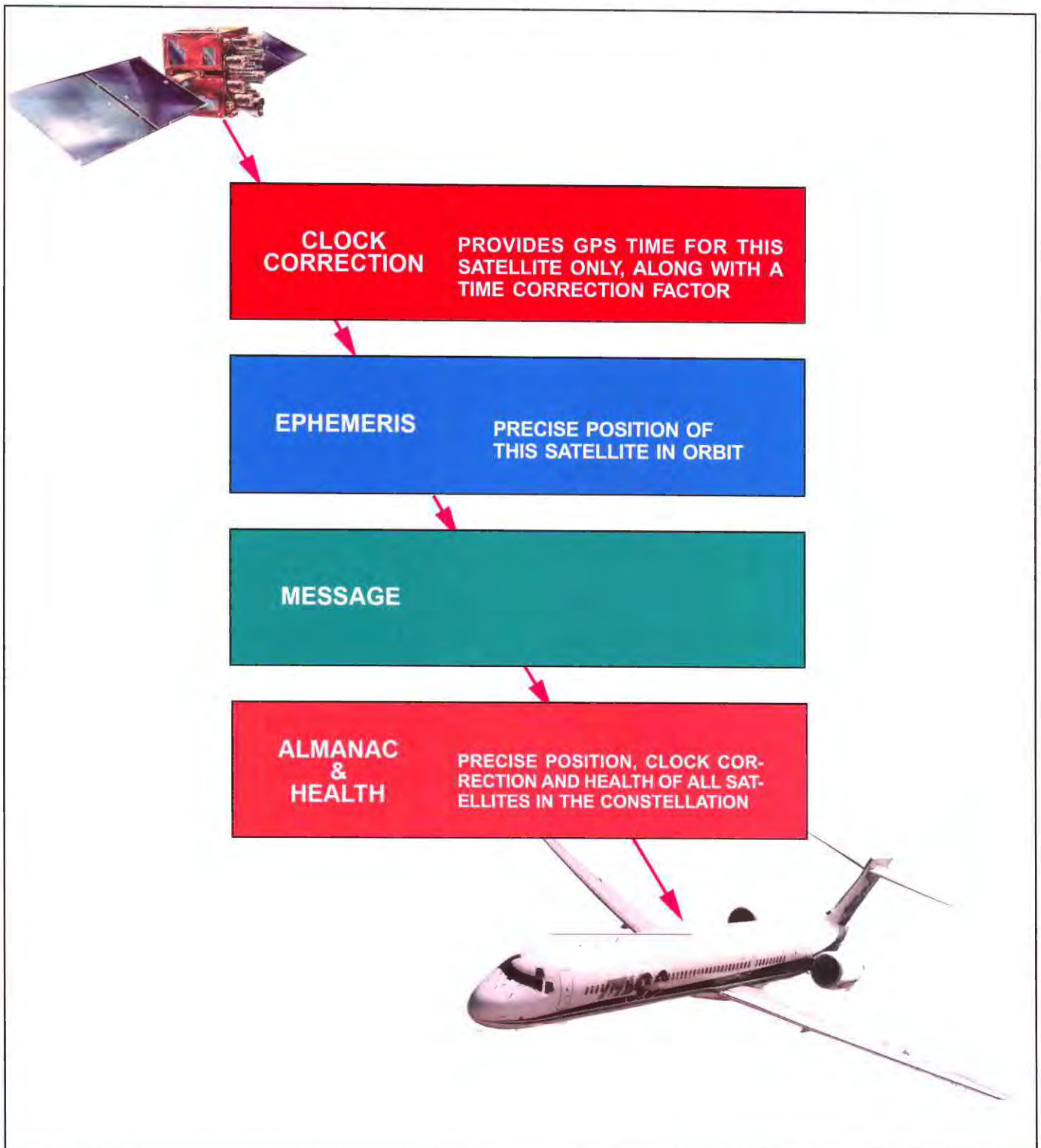

The signal broadcast by a GPS satellite contains “frames” of information. They not only describe the position and health of the satellite, but data for every other satellite in the system.

The first frame is devoted to clock time, used by the aircraft receiver for measuring travel time of the signal (and thus distance).

GPS Segments

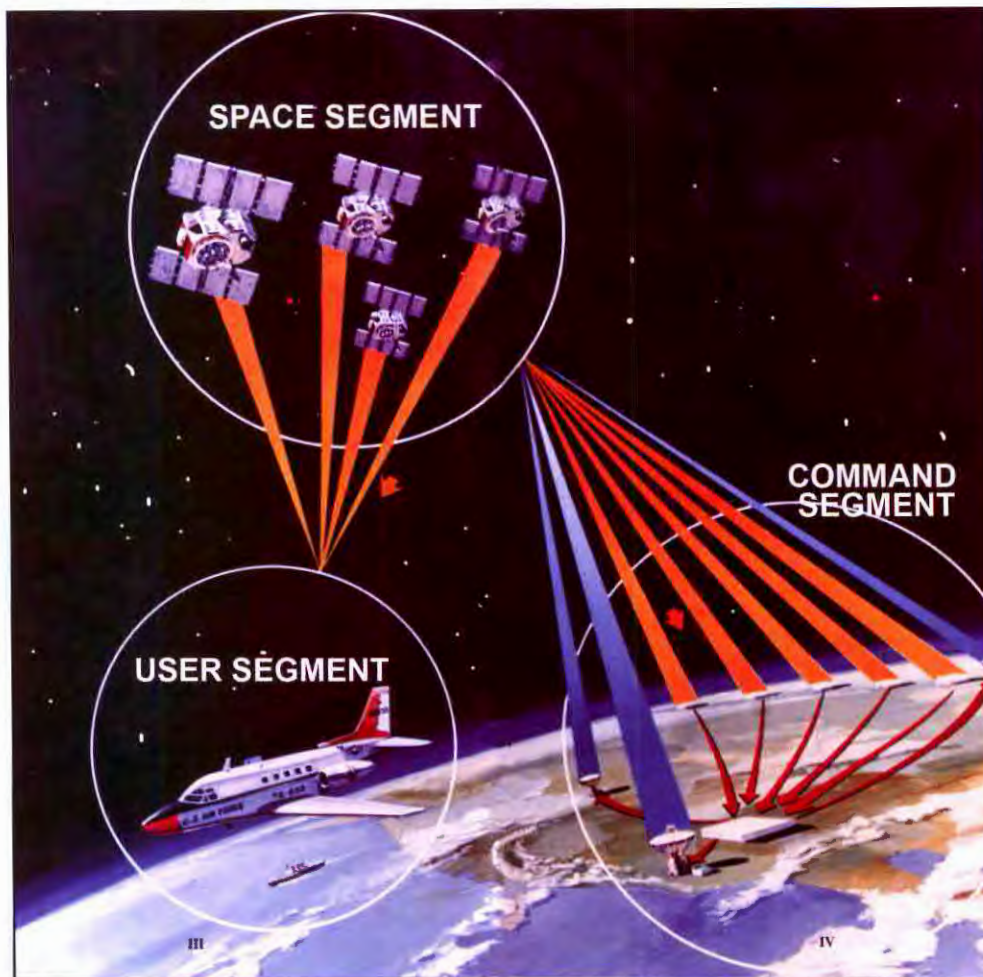

Sundstrand

The three major components of the GPS system:

Space Segment: The satellites, also known as "SV" (satellite vehicle), circle the earth every 12 hours at an altitude of 11,000 miles. At any point on earth, up to ten satellites are in view.

Control Segment: A master control station in Colorado Springs connects to five

or more ground stations around the world. They track satellites for performance and health. Orbit information and clock corrections are uplinked to the satellites several times a day. This data is broadcast on the navigational signal to users.

User Segment: Consists of airplanes, ships, other vehicles and portable GPS.

For an airplane flying over the earth, three satellites provide a 2-dimensional fix; which is latitude and longitude. Receiving four satellites provides a 3-dimensional fix; longitude, latitude and altitude.

WAAS: Wide Area Augmentation System

As GPS spread through aviation, it proved highly successful for cross-country travel between cities. But its full value would never be realized unless it replaced the instrument landing system (ILS), the key to on-schedule operations in almost any weather. GPS would have to equal the performance of a Category I ILS (200-ft ceiling and 1/2-mile visibility). Although GPS accuracy increased when Selective Availability (SA) was

turned off in 2000, it was inadequate for Category I.

The solution in the U.S. is WAAS, or Wide Area Augmentation System. A network of 25 ground reference stations are placed around the country. The location of each station is surveyed with great accuracy. A GPS receiver at the station picks up the satellite signal and compares it with the known geographic position. The difference is the error (mostly due to propagation effects in the ionosphere). The ground stations relay that error to a geostationary satellite, which rebroadcasts it as a GPS signal. Airplanes in the general area of the ground station, therefore, can use the error to correct their GPS position. It is estimated that WAAS

Wide Area Augmentation System (WAAS)

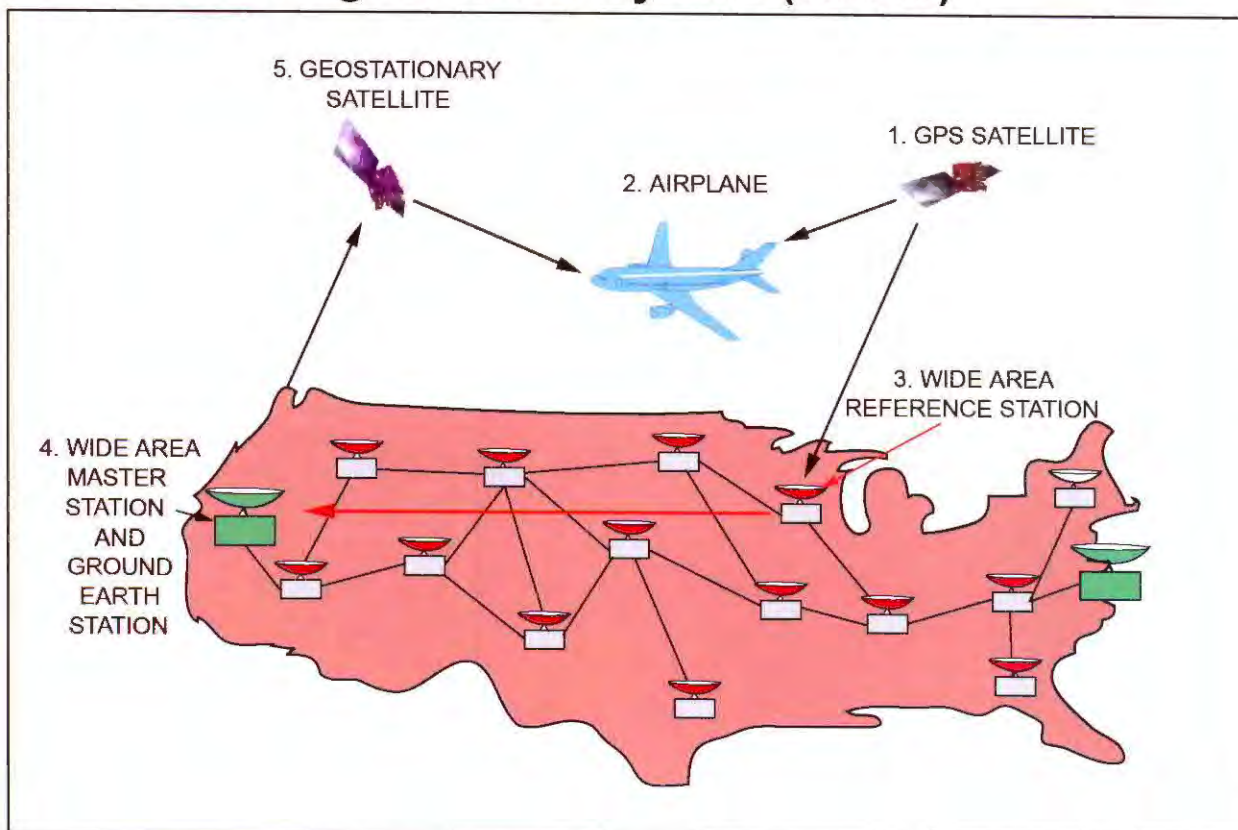

WAAS is a form of differential GPS designed to bring the equivalent of an Instrument Landing System (Category I ILS) to almost any airport. The sequence of events:

1. GPS satellite transmits a navigation signal.

2. The aircraft receives the signal, which has accumulated errors, mainly because of delays through the ionosphere.

3. Wide Area Reference Station. About 25 such ground stations cover continental U.S., spaced several hundred miles apart. They pick up the same signal as the airplane. A ground station, however, knows the error because its location was precisely surveyed. The surveyed location is compared with the position given by the GPS receiver at the ground station---and the error is determined.

4, Ground Earth Station-Wide Area Master Station. The

error is sent cross-country through a network to one of two Wide Area Master Stations (on east and west coasts). A correction is developed.

5. Geostationary Satellite. The correction is sent to a geostationary satellite which appears fixed overhead. The satellite then broadcasts corrections (from every location in the country) to the airplane. This removes the "differential" error and raises accuracy sufficiently for precision landings (vertical and horizontal guidance).

The geostationary satellite transmits the error in a GPS-like format, which can be received as if it were another GPS satellite. Thus, WAAS for an airplane needs no separate receiver.

Several countries have WAAS systems, but call them different names. All systems, however, are compatible and can be used by any satnav receiver.

could add precision instrument approaches to over 5000 airports in the U.S.

Only one WAAS ground station is needed to cover many airports within its coverage area. Continental U.S. can be serviced by only 25 stations. They provide accuracy down to about 1 meter, which satisfies the most critical requirement of Category I, vertical guidance for the glideslope.

Another benefit involves the aircraft receiver. Because the WAAS correction arrives as a GPS signal, a separate receiver is not required. Also, no ground station is required at each airport and an airplane can use

WAAS to approach any runway at the airport (once the approach has been designed and certified by a government agency).

GPS approaches use terminology that is different from that of ILS components, such as localizer and glideslope:

LNAV/VNAV. This refers to "lateral and vertical navigation". "Lateral" is equivalent to the localizer; "vertical" is the glideslope component. LNAV/VNAV provides GPS guidance down to a 350-ft ceiling and 1.5 mile visibility, which is not as good as a Cat I ILS, but offers thousands of airports their first precision (or any) instrument approach.

LPV: Localizer Performance Approach with Vertical Guidance. This improvement reduces the weather minimums to 250-ft ceiling and 1.5-mile visibility. It's still not as good as an ILS Category 1 approach but close to it.

SBAS: Space Based Augmentation System. The WAAS system is used in the U.S., but is also part of an international system known as "SBAS," for space-based augmentation system. It is so-called because it uses geostationary satellites for relaying correction signals. Other countries use different names:

EGNOS: European Geostationary Navigation Overlay Service.

MSAS: Multifunction Transport Satellite System (Japan).

LAAS: Local Area Augmentation System

The first "blind" landing was demonstrated by Jimmy Doolittle in 1927. It is surprising that well into the 21st Century, the complete blind landing was still not achieved. It is true that widebody airliners are often equipped for "autoland," which provides a hands-off

landing and roll-out. But civil air regulations in most countries do not permit it in actual instrument conditions, where the pilot sees nothing beyond the windshield.

This is the "zero-zero" landing---no ceiling and no visibility (or Runway Visual Range). It is known as "Category IIIc." Even Category II requires special equipment aboard the airplane and tighter specifications for the ILS transmitter on the ground. As a result there are few Category III operations anywhere in the world. Another obstacle is that autoland systems can put the airplane on the runway, but there is no guidance for taxiing to the terminal when dense fog blocks any view outside. (This should be solved with emerging "synthetic" and "enhanced" vision systems, which see the runway with infrared light, or construct an image from a mapping database.)

LAAS. A system known as LAAS, for Local Area Augmentation System, raises the accuracy of the GPS landing system above Category I. It is similar to the

Block IIR: Second Frequency for Civil Aviation



GPS continuously improves with each generation. Shown here is a Block IIR satellite (built by Lockheed Martin). The major enhancement is a second GPS signal for civil aircraft to improve accuracy. Earlier satellites provided only one civil signal, which picks up errors when it changes speed through the ionosphere. With two signals, their speeds are compared and used to reduce the error.

The new satellites also provide the military with an "M code," which operates at higher power to improve resistance to jamming.

Set up for a GLS Approach



Every GLS approach has a unique 5-digit channel number, in this example, "30915." Above it is "GLSA" to identify it as a GLS approach. The display is a page in a Flight Management System typical of a large transport. Once the GLS channel is selected, the pilot (or flight control system) is guided through courses and altitudes to make the approach to the airport. This example is the approach to Runway 32L (left) at Grant County International Airport in Washington State.

wide area system (WAAS) described above, except that the ground monitoring station for correcting error is located on the airport. Because GPS error is sensed within hundreds of feet (not miles) from runways, the correction provides high accuracy in the airborne receiver. As shown in the illustration, corrections are not relayed via an orbiting satellite, but through a VHF station whose signal is picked up by the airplane. Now the accuracy of navigation is down to 1 meter, and satisfies the demands of vertical descent. It can also provide a moving map of runway and taxiways for the pilot to find his way to the terminal in the densest fog.

The international term for the LAAS system is GBAS, for “ground-based augmentation system”. It refers to the VHF ground stations that transmit the correction signal.

Multimode Receivers. The aviation world is in a long-term changeover from ILS to GLS, and both systems will exist side by side for many years. For this reason, many new long-range aircraft are equipped with MMR---multimode receivers--- that operate on all systems, including Microwave Landing System (MLS), VOR, ILS and GLS. No matter what system is in operation at an airport, the pilot sees the same steering commands on his instruments and displays.

RAIM: Receiver Autonomous Integrity Monitoring

During the transition to satnav, GPS will not be certified for instrument approaches unless there is a back-up system on the airplane in the event of failure. The backup may be another form of navigation, such as ILS (instrument landing system). The pilot must not only monitor the GPS, but the other source, as well. This is hardly practical and places a heavy workload on the pilot.

To avoid this problem, the RAIM system was developed, which enables the GPS receiver to check itself. Meaning “Receiver Autonomous Integrity Monitoring,” RAIM checks whether there are enough satellites for the approach, whether they are healthy and if their geometry is adequate. The last factor, geometry, is the layout of satellites during reception; their signals must arrive from widely different angles for the GPS receiver to develop an accurate position.

It usually takes four satellites to determine longitude, latitude, altitude and a correction for the receiver clock. RAIM is accomplished by receiving at least five satellites, which should be possible anywhere in the world. The receiver searches for the best satellite combination and, when satellites drop below the horizon, new ones are acquired as they rise into view. Five satellites assure that integrity is sufficient to fly the instrument approach. The GPS receiver will “look

LAAS for High Accuracy

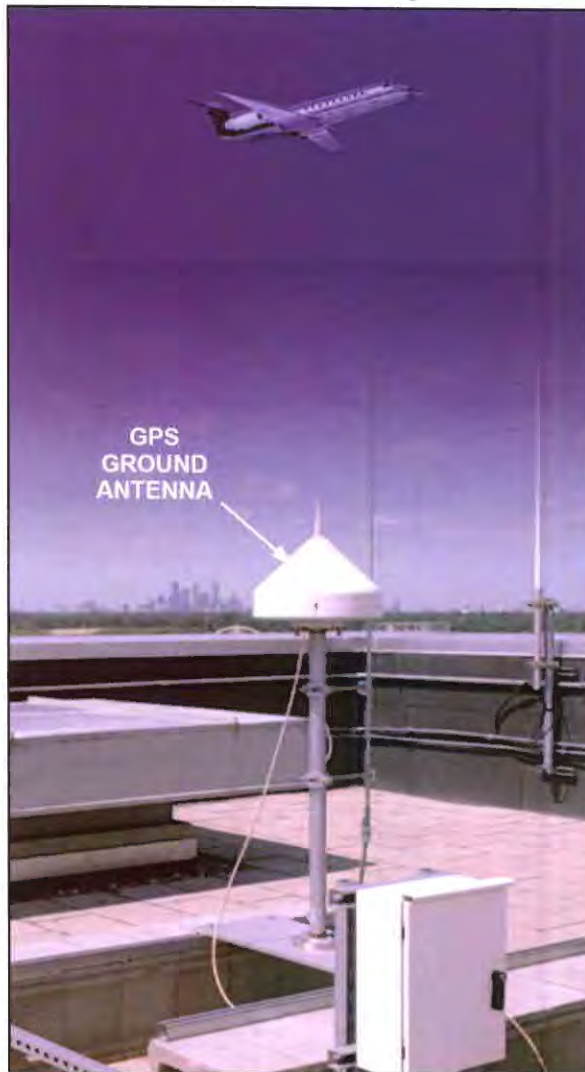

Honeywell
A Local Area Augmentation System (LAAS) installed at an airport. The GPS ground station receives the same satellites as the airplane. The station location, however, was surveyed and its precise position known. If it detects differences between its known geographic location and GPS position, a correction is transmitted to the airplane.

The technique is called “Differential GPS” (DGPS) because it detects error as a “difference” signal. Internationally, it’s called “GBAS,” for ground-based augmentation system.

ahead” and determine if RAIM will be acceptable before the airplane commences the instrument approach. If it’s inadequate a warning appears; “No GPS RAIM.”

Galileo Constellation

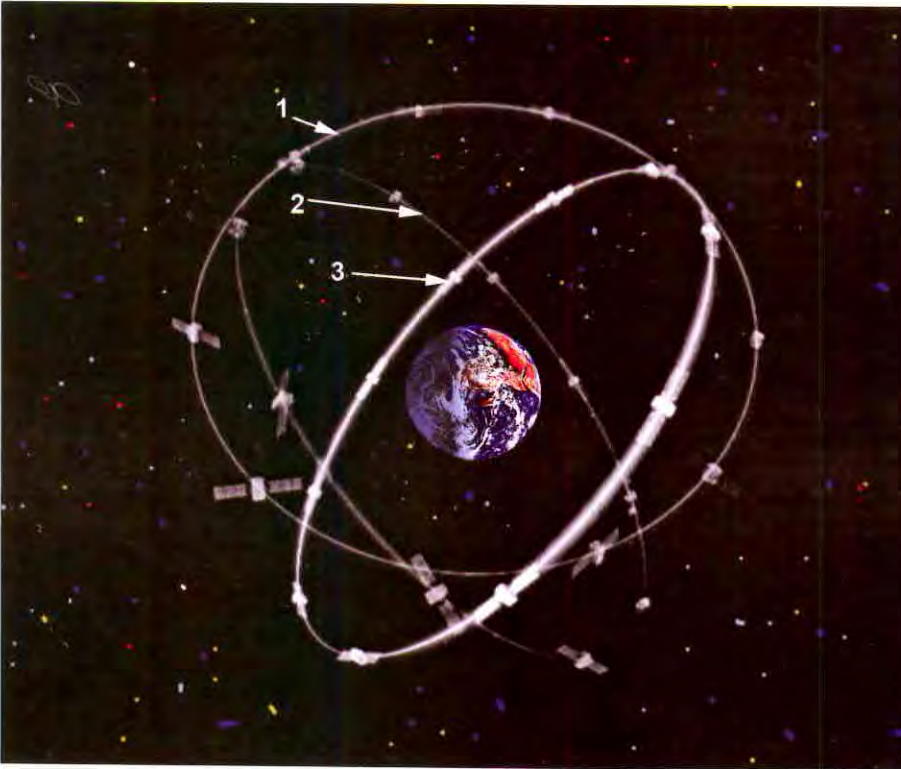

The European system, Galileo, inserts 30 satellites into orbit, with three standing by as spares. Unlike GPS, which has six orbits, Galileo has three (shown in the illustration).

The constellation, at an altitude of 14,600 miles (23,616 km), is slightly higher than GPS (12,500 miles).

Two ground stations in Europe gather data from 20 sensor stations around the world and uplink data to synchronize clocks and maintain orbits.

The source of Galileo's timing accuracy are two clocks carried aboard each satellite. One is a rubidium atomic clock (as in GPS), the other is a newer type, "passive hydrogen maser."

Galileo is interoperable with GPS; a receiver aboard the airplane processes both signals.

Galileo Satellite

Solar panels, which generate 1500 watts of primary power, rotate with the satellite around an earth-pointing axis. The panels are kept facing the sun, while navigation antennas point toward earth. Each satellite weighs 1400 pounds (650 kg).

A goal of Galileo is to achieve navigational accuracy to within 5 meters without augmentation systems on the ground (see WAAS and LAAS).

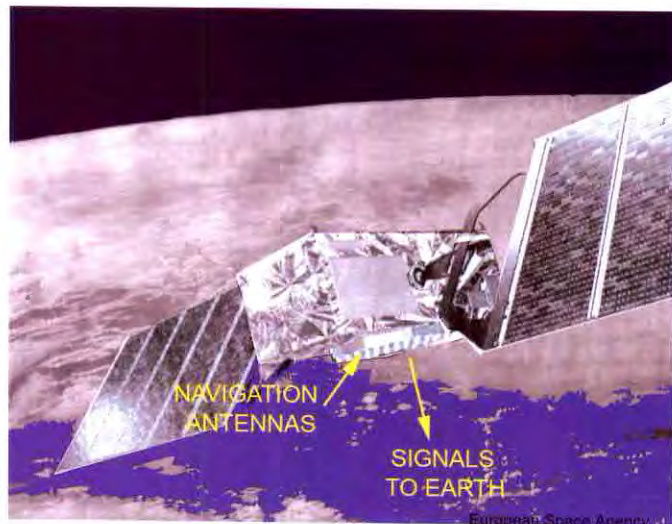

Review Questions

Chapter 16 GPS/Satnav

- 16.1 How many satellites are there in a GPS constellation?
- 16.2 How many GPS satellites are active? How many are spares?
- 16.3 What is the European equivalent of GPS?
- 16.4 Why don't GPS receivers in airplanes require expensive atomic clocks (like those in satellites) to measure time with high accuracy?
- 16.5 How does a GPS receiver identify a satellite?
- 16.6 What is the term for a satellite's identity?
- 16.7 How does a GPS receiver measure the time for the signal to travel from satellite to receiver?
- 16.8 How is distance determined between the GPS receiver and the satellite?
- 16.9 GPS frequencies, or channels, are designated by the letter _____
- 16.10 How many satellites are required for a three-dimensional fix (latitude, longitude and altitude)?
- 16.11 How many satellite frequencies are required to perform propagation corrections?
- 16.12 What part of the satellite signal carries the satellite's precise position in orbit?
- 16.13 Name the three segments of the GPS system.
- 16.14 The Wide Area Augmentation System (WAAS) uses ground stations and satellites to _____
- 16.15 What is the advantage of LAAS (Local Area Augmentation System) over WAAS?
- 16.16 What is the purpose of RAIM (Receiver Autonomous Integrity Monitoring)?

Chapter 17

EFIS

Electronic Flight Instrument System

Along with digital electronics and GPS navigation, the Electronic Flight Instrument System changed the face of the flight deck. The term EFIS originally described an airline system (that first rolled out with the Boeing 767 in 1981) but today it identifies electronic instruments for aircraft of all sizes.

EFIS is often called the “glass cockpit” because TV screens replace mechanical and electromechanical instruments. Dozens of old “steam gauges” are now replaced by an EFIS display that is rapidly changing from about a half-dozen separate screens to “wall-to-wall” glass.



Replacing Old Instruments



Electronic instruments are also designed as direct replacements for old electromechanical equivalents. In these two examples, the instruments are LCD that provide both analog and digital read-outs. Reli-



Aerospace Display Systems

ability of these solid-state devices is much greater than that of mechanical types.

The instrument on the left is a torque indicator used in military helicopters. The one on the right is a vertical torque indicator for commercial helicopters

Electronic instruments bring many benefits. They eliminate hundreds of gears, bearings, pointers, rotating drums and other fragile mechanical components. Any instrument is easily duplicated on the screen by programming its image.

Instead of spreading information over different instruments on the panel, EFIS overlays them into a single, easy-to-understand image, for example; a map display can also show thunderstorms, high terrain and nearby aircraft.

An EFIS display may be decluttered to show only information required for that phase of the flight. If there's an "exceedance," meaning a system is developing a fault, it automatically appears to warn the pilot.

Because there is almost no limit to what can be shown as an image on a screen, EFIS brought in new generations of symbols that are pilot-friendly. The first systems simply created pictures of instruments they replaced, but it became apparent there were better images. For example, pilots fly an ILS (instrument landing system) by keeping two needles centered; one for

EFIS Pictorial Display

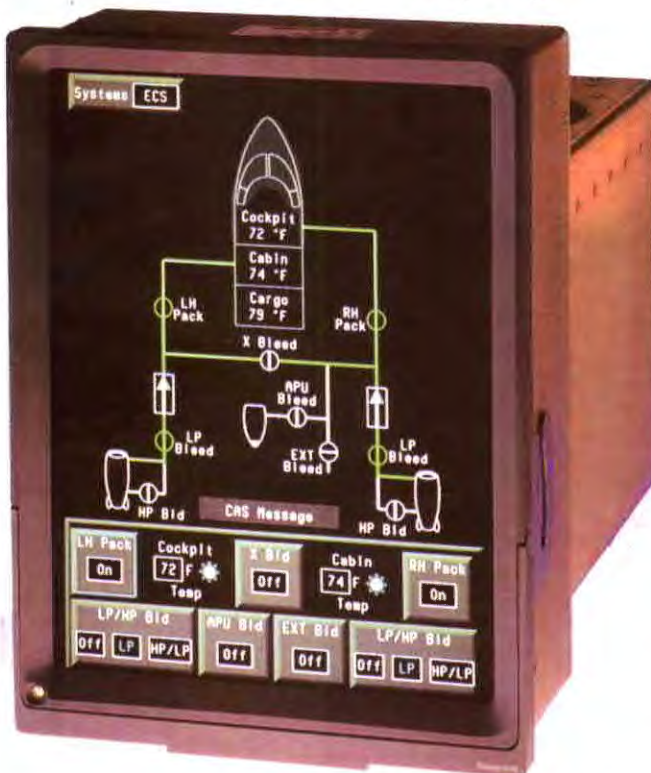

Honeywell: Primus Epic

An example of how EFIS presents an easy-to-read pictorial view. This environmental control system was once a collection of knobs and gauges on an overhead panel. Now it's in the instrument panel. At a glance, the pilot sees how bleed air flows from the engines (lower left and right) and is distributed for controlling temperature in the cockpit and passenger cabin, including position of valves.

Also shown is bleed air from the APU (auxiliary power unit) and from an external source (just below center of screen).

This presentation is more useful for troubleshooting the system in flight than consulting a paper manual.

the localizer to remain on the runway centerline, the other a glideslope for vertical guidance. In a series of experiments by NASA, the “highway in the sky” was developed. The pilot aims the airplane at a rectangle (or hoop) on the screen and flies through it. Additional hoops appear in the distance; if the pilot keeps flying through them (like threading a needle), the airplane remains on the localizer, glideslope or other 3-dimensional path.

The original technology for EFIS was the heavy glass cathode ray tube. Flat panel LCD’s of the 1970’s were not ready for aviation; they were monochrome,

had narrow viewing angles and low resolution. Driven by the large market in portable PC’s, the technology advanced rapidly and all new EFIS systems are flat panel.

There is much retrofitting of old aircraft to replace their electromechanical instruments with EFIS. It’s happened in most major transport aircraft in “derivative” models, usually shown by a “dash number;” for example; the Boeing 737-100 first rolled out in 1967 with conventional instruments. It is now up to 737-900, with recent generations equipped with EFIS.

Transition from Electromechanical to EFIS

This EFIS screen is a “Primary Flight Display” and combines many early instruments into a single screen. The top half was once the artificial horizon. One of the first improvements was the addition of “command” bars--the V-shape near the middle of the screen. Driven by the flight control system (autopilot), the bars helped guide the pilot fly manually or enabled him to observe commands of the autopilot. At this stage, the instrument was called an “ADI,” for attitude director indicator.

When EFIS appeared, all the same functions were pictured on a video screen. This called for a new name, EADI, for electronic attitude director indicator. At the same time, several other instruments were added to the image; air speed indicator, altimeter, vertical speed indicator and others.

The lower half of the screen was once the horizontal situation indicator (HSI). When the electromechanical instrument is shown on an EFIS screen it is known as an EHSI, the “E” is for electronic.

When the two major flight instruments---ADI and HSI---are placed one above the other and connected to the autopilot, they are known as a “flight director.”

The trend in EFIS, however, is to combine those instruments onto one screen, as shown here, and call it a “Primary Flight Display.”

The system in the illustration is the Honeywell Primus EPIC, a flat panel measuring 8-in by 10-in.

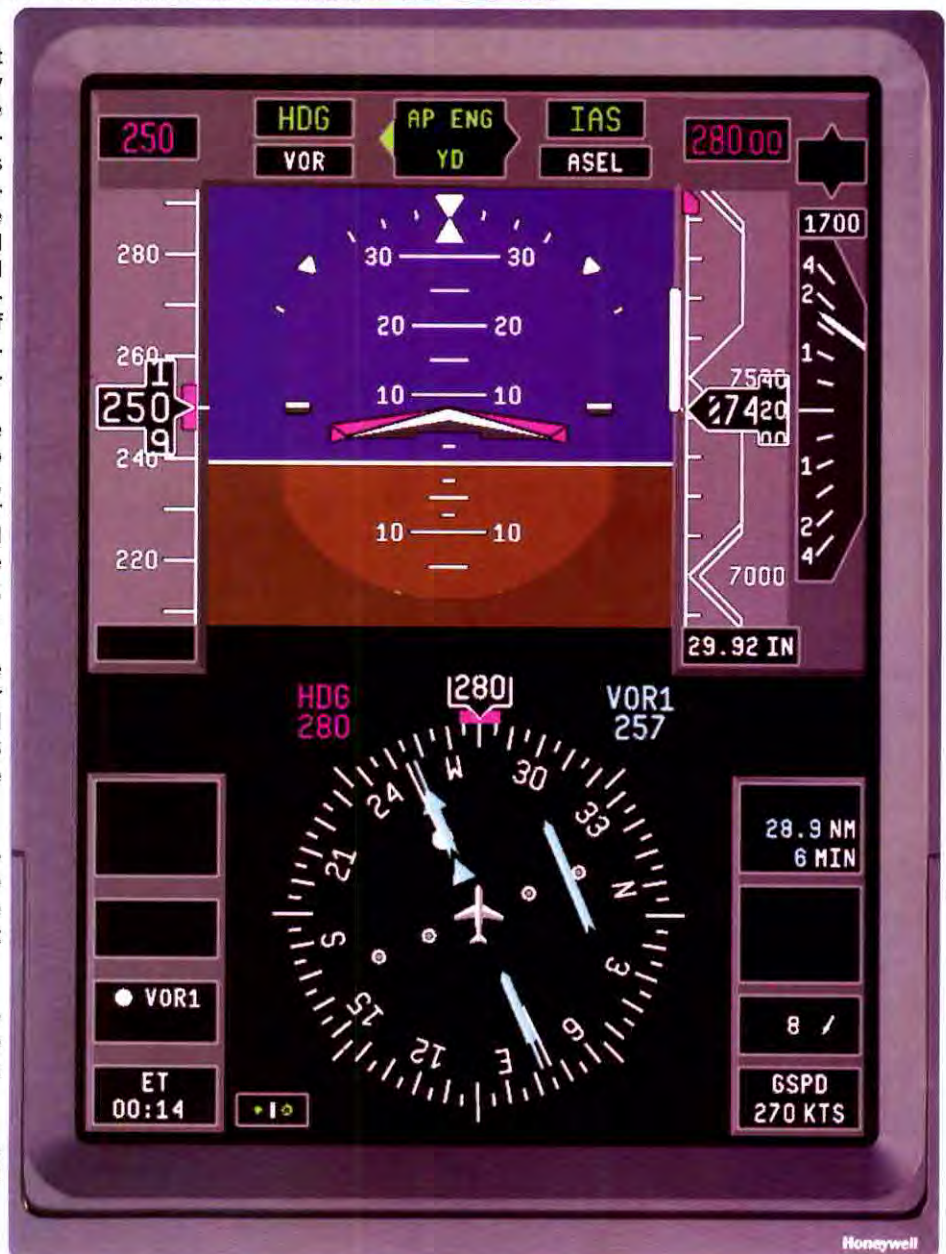

Three-Screen EFIS

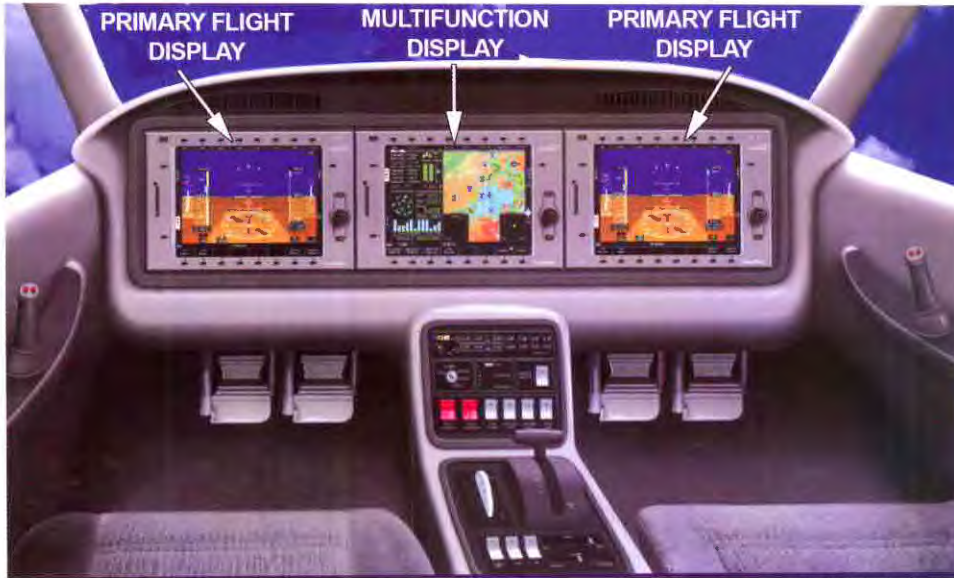

L3 Communications

The future of instrument panels is shown in this “Smartdeck” by L3 Communications. It is “wall-to-wall” glass, with three 10.5-inch panels that display information once required by three separate instruments.

Panels like these are usually interchangeable, with their function determined by how their software is programmed. This permits “reversionary modes,” meaning that any display on one panel can be switched over to another.

The panels are arranged as Primary Flight Displays for captain (left) and first officer (right). In the center is the multifunction display. Because the multifunction display typically displays engine instruments and warnings it is also called EICAS, for engine instrument and crew advisory system.

The Primary Flight Display is mainly for controlling the attitude of the airplane and for navigating.

Primary Flight Display

Attitude	Engine Power
Heading	Selected Heading
Altitude	Selected Course
Airspeed	Autopilot/Flight Director
Vertical Speed	Navigation
Lateral/Vertical Path	Timer

Multifunction Display

Radio Management	Charts
Aircraft Systems	Runway Diagrams
Engine Instruments	Wind Direction/Speed
Checklists	Ground Track
Moving Map	Caution/Warning
Flight Plan	Geographic Overlays
Terrain	Lightning/Weather
Datalink (Traffic/Weather)	Traffic Information

EFIS Architecture

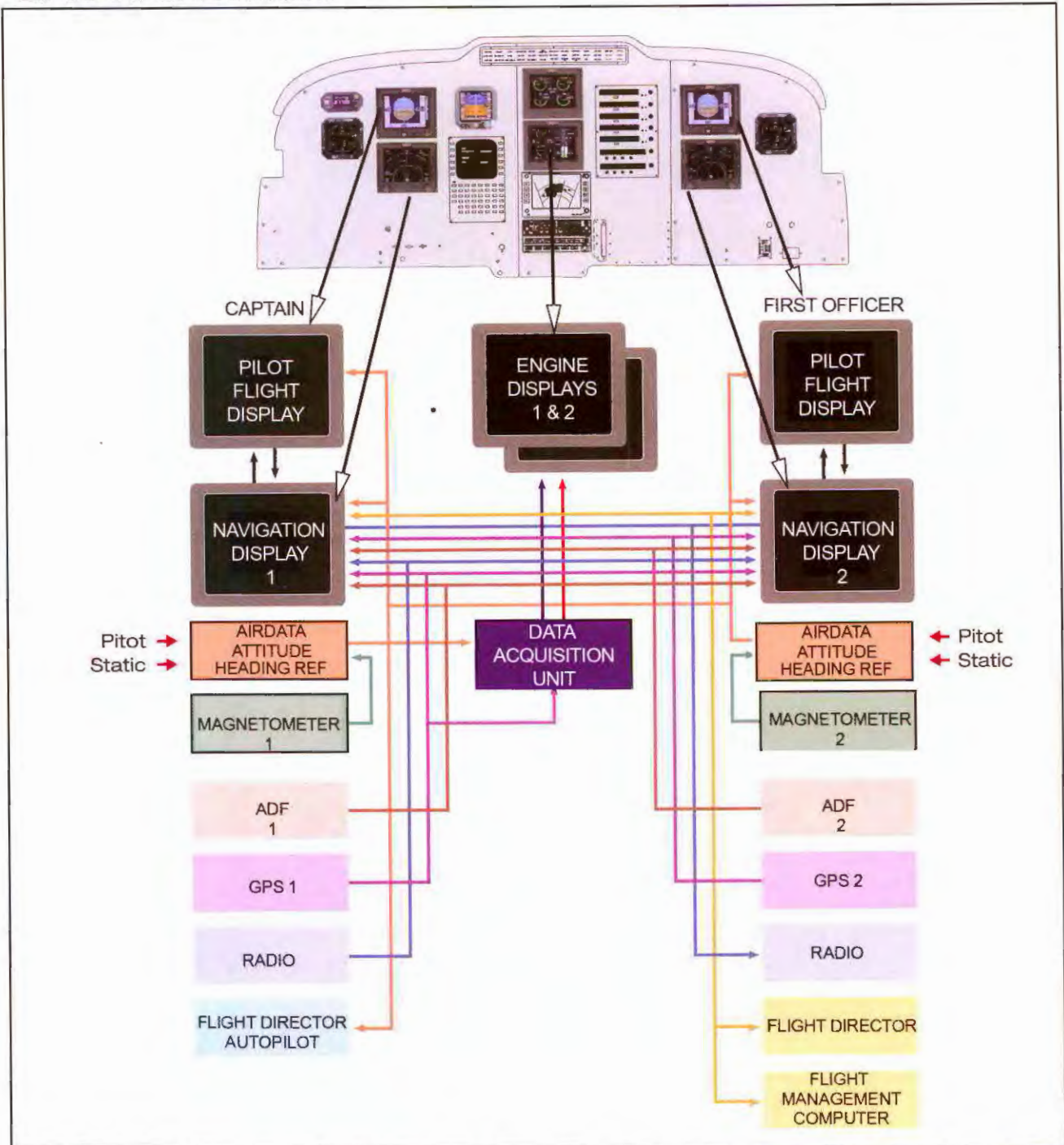

An EFIS system requires inputs from various sources, as shown in this system known as "MAGIC," for Meggitt Avionics new Generation Integrated Cockpit."

Because the electronics are digital, any analog signals from outside must go through the Data Acquisition Unit (DAU). Signals from engine sensors and fuel probes, for example, are converted to digital format. The DAU can also store data for engine trend monitoring, which can detect faults before they cause a failure.

The Air Data Attitude Heading Reference System (ADAHRS) replaces conventional sensors for measuring

temperature, pressure, altitude, airspeed and others. It also eliminates "spinning iron" gyro's for aircraft attitude and heading. It's done with solid-state devices containing almost no moving parts.

Note how the instrument panel is divided into to nearly identical halves; for captain and first officer (co-pilot). This provides the safety of redundant systems, which are powered from different sources. In a typical EFIS a display on one side of the panel can be switched and viewed on the other side.

Multifunction Display: MFD

One MFD, like this Apollo MX-20 displays a wide variety of navigation, weather and traffic information.



The 360-degree compass rose is a horizontal situation indicator. The red, yellow and green areas are terrain warnings.



This screen shows weather radar images and works with several makes of radar sets.



Weather shown here is not from aircraft radar, but signals from NEXRAD, a nation-wide system of government ground radars. The pilot may select weather images from any area of the country.



Horizontal Situation Indicator with waypoints along the route. Also shown is nearby traffic; targets appear as small blue arrowheads.



Navigational charts for enroute and approach phases of flight. When the airplane lands, the chart changes to a taxi diagram.

EFIS on the B-747-400

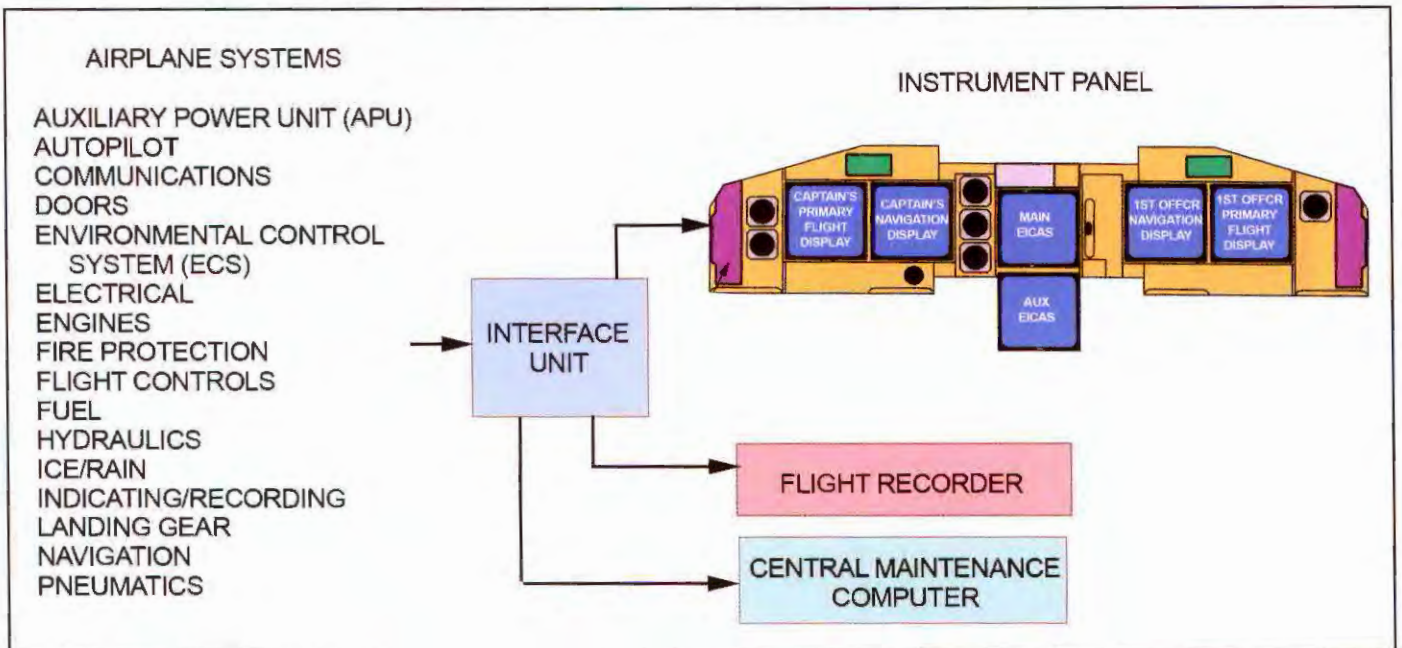
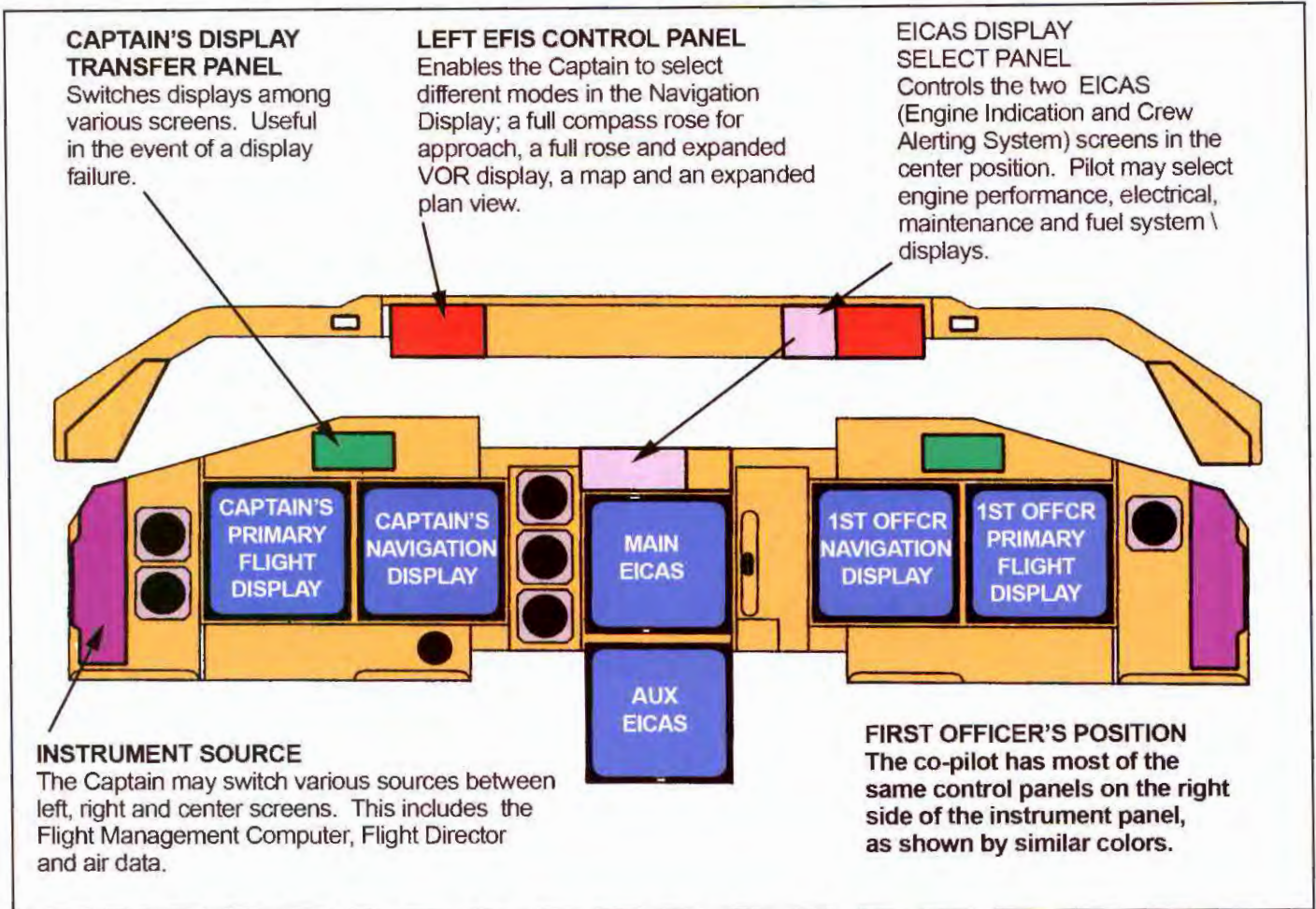

Information from airplane systems is applied to an interface unit. The data is digitized and symbols generated for displaying images on the EFIS and

EICAS screens. The interface also sends some of that data to the flight data recorder and the central maintenance computer for storage.

Airbus A-320 Flight Deck



The A-320 began flying in 1988 as a twin medium-range transport. Because EFIS panels are interchangeable, fewer spares are required for maintenance.



A feature of the A-320 is the absence of control yokes for captain and first officer. Yokes are replaced by two sidestick controllers, as found in fighter aircraft. This gives a wide, unobstructed view of the instrument panel.

It is also "fly-by-wire," where the sidesticks drive computers that, in turn, control actuators for rudder, ailerons, elevator and spoilers. Safety is assured by operating each sidestick through five computers, each with different software, microprocessors and manufacturers.

The advantages of fly-by-wire: large mechanical linkages and cables are eliminated, less weight, built-in test and flight envelope protection (which prevents excessive control inputs). It also provides "gust load alleviation," which senses turbulence, then operates aileron and spoiler to relieve strain on the wingtips. This enables a lighter, longer wing for better fuel economy.

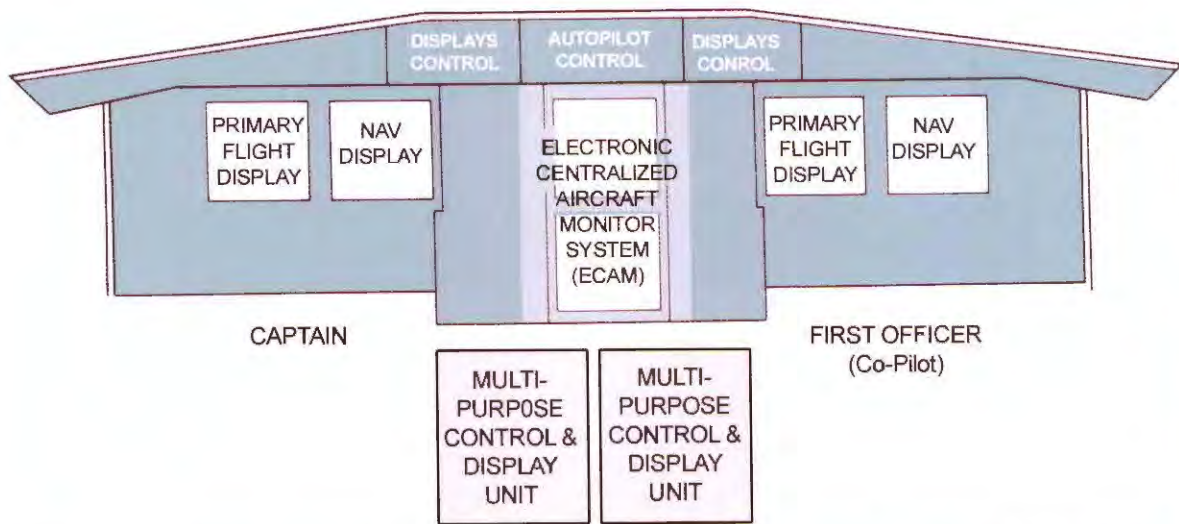

The instrument panel of the A-320 has six main CRT displays, all physically interchangeable. This eliminates 75% of conventional instruments.

The two screens in the center (ECAM) monitor engines, flap and other settings, and system malfunctions.

The two multipurpose displays at the bottom have built-in test equipment (BITE) that show malfunctions, diagnostic data and failed components. It reduces the prob-

lem of returning a unit to the shop and finding nothing wrong (a major cost item for the airlines).

The engine thrust levers are controlled by FADEC (Full Authority Digital Engine Control). It adjusts fuel and power setting for best efficiency. Weighing less than the conventional (hydro-mechanical) system, FADEC also provides engine protection (from exceedances) and health monitoring.

Review Questions

Chapter 17 EFIS

17.1 What are two benefits EFIS?

17.2 The EFIS screen directly in front of the pilot, which shows attitude instruments, is called a _____.

17.3 The EFIS screen usually in the center of the instrument panel is the _____.

17.4 The center screen of a typical airline displays EICAS, which means _____.

17.5 An EFIS system can display BITE, which stands for _____.

17.6 The control yokes on recent Airbus aircraft are replaced by sidestick controllers. Why?

17.7 First-generation EFIS was based on cathode ray tubes. What replaced them?

17.8 Why are fewer spares required to maintain an EFIS system?

17.9 What can a pilot do if images fail to appear on his EFIS screen?

17.10 Why is it easier to troubleshoot a problem in flight with an EFIS-equipped airplane?