

1 - NOV. 1934

PATENT SPECIFICATION

417,564



Application Date: Dec. 28, 1932. No. 11,628/34.

(Divided out of No. 417,501.)

Complete Left: Dec. 15, 1933.

Complete Accepted: Sept. 29, 1934.

PROVISIONAL SPECIFICATION.

Improvements in Devices for Generating Electromagnetic Fields Oscillating with Quasi-optical Frequencies.

I, JAMES YATE JOHNSON, a British Subject, of 47, Lincoln's Inn Fields, in the County of London, Gentleman, do hereby declare the nature of this invention (which has been communicated to me from abroad by Ternion Aktiengesellschaft, of Glarus, Switzerland, a Joint Stock Company organized under the Laws of Switzerland) to be as substances and substances assuming dipole characteristics for the purpose of altering their energy contents and their physical and chemical qualities as well as for releasing chemical reactions between such substances by means of dielectric molecular resonance, resonance polarization or the like, in such manner that the effects can be exploited technically.

ERRATA.

SPECIFICATION No. 417,564.

Page 2, line 34, for "and" read "an"
Page 10, line 59, for "epsilon_1" read "epsilon_2"
Page 10, line 69, for "epsilon CC, 1/r_2" read "epsilon CC 1/r^2,"

PATENT OFFICE,
December 5th, 1934.

If the apparatus, termed herein a "plate-oscillator" is being supplied with an alternating current of frequencies of frequency, similarly to an aerial with longer waves. This similarity only holds good when considering the oscillator as

Memo To Librarians

SPECIFICATION No. 417,564.

The provisional drawing was inadvertently omitted from the above-numbered printed Specification. The drawing has now been printed and should be attached between the letterpress and the complete drawings.

THE PATENT OFFICE,
11th May, 1936.

[Price 1/-]

1- NOV. 1934

PATENT SPECIFICATION

417.564



Application Date: Dec. 28, 1932. No. 11,628/34.

(Divided out of No. 417,501.)

Complete Left: Dec. 15, 1933.

Complete Accepted: Sept. 29, 1934.

PROVISIONAL SPECIFICATION.

Improvements in Devices for Generating Electromagnetic Fields Oscillating with Quasi-optical Frequencies.

I, JAMES YATE JOHNSON, a British Subject, of 47, Lincoln's Inn Fields, in the County of London, Gentleman, do hereby declare the nature of this invention (which has been communicated to me from abroad by Ternion Aktiengesellschaft, of Glarus, Switzerland, a Joint Stock Company organized under the Laws of Switzerland) to be as follows:—

The invention relates to devices and apparatus for the generation of concentrated electro-magnetic fields for quasi-optical and electro-optical purposes as well as for increasing the influence of electro-magnetic fields on substances.

The way to direct electro-magnetic fields by reflectors or by means of Hertzian parabolic mirrors is already known; however, these known devices do not allow for the concentration of substantial amounts of energy and therefore it is not possible for these amounts of energy to effect appreciable influences on substances which are under treatment.

It is the purpose of the invention to avoid this disadvantage by the construction of a device which makes it possible to effect a particularly strong concentration of the electro-magnetic field. For this purpose a thin layer of the substances to be influenced is brought between two electrodes having the form of plates.

If the apparatus, termed herein a "plate-oscillator" is being supplied with an alternating current of frequencies of the ultra-short wave or quasi-optical wave range there arises within the plate gap a concentrated electro-magnetic field, when the frequencies of the alternating current are selected such as to excite the plate oscillator to natural oscillations.

These concentrated electro-magnetic fields are employed for making visible conditions of quasi-optical oscillations, for controlling any given light intensities and for the optical reproduction of music. Beyond this the devices according to the invention are particularly suitable to effect an influence upon dipole-

substances and substances assuming dipole characteristics for the purpose of altering their energy contents and their physical and chemical qualities as well as for releasing chemical reactions between such substances by means of dielectric molecular resonance, resonance polarization or the like, in such manner that the effects can be exploited technically.

The plate-oscillator resembles in its external form, but not in its electrical behaviour, a condenser. In a modification which is especially suitable in practice it consists of two oppositely arranged plates. By reason of the distributed self-induction and distributed capacity which every electric conductor has, the plate-oscillator also has an electric resonance. By reason of the smallness of the distributed self-induction and distributed capacity, this resonance lies at very high frequencies. For example with circular plates having a diameter of 10 centimetres and spaced 1 centimetre apart the natural frequency lies at a wavelength of about 30 centimetres. By employing larger plates the wavelength increases and vice versa. Similarly the wave-length increases when the plates are spaced at shorter distances apart. When in circuit the plate-oscillator behaves, when it is worked in the neighbourhood of or exactly in its natural frequency, similarly to an aerial with longer waves. This similarity only holds good when considering the oscillator as a circuit element, i.e. it has the said natural frequency by reason of distributed capacity and self-induction, and therefore it has radiation resistance and also loss resistance. While the aerial—or in the range of short waves, the Hertz dipole—radiates towards the exterior, in the plate oscillator the whole of the electromagnetic oscillation energy is concentrated in the space between the plates. This is fundamentally different from the aerial and is an unknown kind of energy concentration. The whole oscillation energy, which when employing dipole

aerials is distributed in space, is concentrated in a volume which only amounts to a few cubic centimetres depending on the dimensions of the plate-oscillator.

5 In the case of resonance there is formed on the plate oscillator a quite definite voltage distribution, or a corresponding field distribution in the space between the plates. By employing large powers

10 of oscillation, this field distribution (hereinafter referred to as the "configuration" of the field) may be reproduced optically with the aid of the orientation of the molecules caused in

15 dipolar substances. For that purpose it is necessary that the plates be made transparent while maintaining good conductivity. By cathodic atomisation of a metal, as for example gold, plates may

20 be prepared which have a light absorption of from about 10 to 15 per cent. per plate. By introducing a thin layer of dipolar substance (i.e. a layer which alters the electrical properties of the plate-oscillator as little as possible or not at all)

25 between the plates of the plate-oscillator which is transparent, and by observing this layer in polarised light the configuration may be rendered clearly visible.

30 In order that it may be more clearly understood, the optical arrangement is diagrammatically represented in Figure 1 of the accompanying drawing in which 1

35 is a source of light, 2 and arrangement of lenses, 3 Nicols' prisms, 4 the plates of the plate-oscillator coupled to the transmitter, 5 a layer of dipolar substance and 6 a screen. On the screen the zones where double refraction occurs in the

40 dipolar substance corresponding to the configuration of the field are rendered light or dark depending on the position of the Nicols. The whole configuration is projected onto the screen. If the plates

45 be excited in their fundamental oscillation by tuning the frequency of the loosely coupled transmitter correspondingly, there appears on the screen a configuration as shewn in Figure 2a. The

50 greatest field strength prevails in the centre and the field strength diminishes continually towards the edge. This configuration, as hereinafter described in greater detail, is especially suitable for

55 the construction of a practically inertialess light relay. It is only necessary to screen off the edge parts by a circular mask and to modulate the source of oscillations in order to obtain a regulation

60 of the beam of light with the optical arrangement shewn in Figure 1.

Similarly to an aerial, the plate-oscillator may be excited not only in its fundamental oscillation, but also in its higher

65 harmonics. There is, however, a dif-

ference. It is customary to excite aerials in higher harmonics which are integral multiples of the fundamental oscillation. With the plate-oscillator, however, its characteristic higher harmonics are usually not integral multiples of the fundamental oscillation. The exact position of the upper frequencies depends on the electrical and mechanical configuration of the plate oscillator.

The plate-oscillator need not consist of two oppositely arranged circular plates as shewn in Figure 3a. On the contrary, for example when it is desired to obtain a field strength as homogeneous as possible in a large volume, it may consist of a convex plate or plates (Figures 3b and 3c), or, when it is desired to obtain especially great field strength in the middle of the space between the plates, it may consist of concave plates (Figure 3d). The coupling of the plate-oscillator need not be in the centre or centre of gravity. The supply of voltage may also be effected eccentrically. (Figure 3e). The coupling may also be effected at two or more points on the plates (for example as shewn in Figure 3f). Furthermore, the edges of the plates may have a shape other than circular, as for example the shapes shewn in Figures 4a and b. In short, the plate-oscillator may be widely varied by altering the distance between the plates, the shape of the plates and the points of coupling. In all these modifications there is a certain distributed capacity and a certain distributed self-induction the product of which determines in known manner the fundamental natural frequency. As already stated, the spectrum of the higher natural frequencies of a plate oscillator depends in a large degree on its size, shape and manner of coupling. The plate-oscillator behaves analogously to an acoustic membrane during mechanical oscillatory excitation. For the simplest case of the circular plate-oscillator coupled exactly in the centre, Figure 2 shews some especially important higher natural frequencies with their configurations. In the experiments forming the basis of these diagrams, the distance between the plates amounted to 1/10th of the diameter of the plates and the thickness of the layer of dipolar substance amounted to 1/100th of the diameter of the plates. With a diameter of the plates of 10 centimetres, the fundamental frequency, in order to give a concrete example, corresponds to a wave length of 30 centimetres. The configuration having one circle (Figure 2b) is obtained by excitation with a transmission wave of 13 centimetres, the configuration having two circles (Figure 2c) 130

by excitation with a wavelength of 8.33 centimetres and the configuration having three circles (Figure 2d) with a wavelength of 6.2 centimetres.

- 5 If the plates are provided with a transparent especially thin conducting layer so that the electric conduction is already considerably diminished (this is the case when light absorptions of only from 1 to 5
- 10 per cent per plate occur) the loss resistance of the plate system is strongly increased. The resonance curve of the plate-oscillator is wide. Such a wide resonance curve which is also given when the
- 15 oscillator is formed from oppositely arranged wire gauze, is in certain cases advantageous for a series of purposes for which the plate-oscillator may be employed.
- 20 If the plate-oscillator has but slight internal losses, i.e. if the layer of dipolar substance interposed is sufficiently thin, and if the conductivity of the plates is good, i.e. if it has sharply pronounced
- 25 resonance properties, a very loose coupling between oscillator and transmitter is necessary in order to avoid back actions to the transmitter. With a wide resonance curve of the oscillator, the
- 30 coupling may be more rigid. The loose coupling of the oscillator is effected in analogy to high frequency technique. Some examples of the practical carrying out of this coupling are given in Figures 4
- 35 and 5. The modifications 5a to 5d in which S is the energising source all amount to effecting the coupling of the oscillatory energy through a small partial capacity which with plates of 10 centimetres in
- 40 size, for example, may have values of from 1/10 to 2 centimetres capacity. Partial capacities of this order are obtained according to the modification
- 45 shewn in Figure 5a by providing for each plate a ball with a wire ring arranged around the same at a distance of a few millimetres, in Figure 5b by providing
- 50 these in so far as the partial capacity is formed directly between the plates of the oscillator and a counter electrode. This modification has the advantage that
- 55 the points of coupling to the plates may be readily varied. For the range of frequency coming into question here, capacity coupling is especially simple and suitable. It is not essential to employ
- 60 capacitative coupling. A further modification of the coupling is shewn in Figure 5e in which the transmitter is coupled inductively and galvanically with the plate-oscillator through a short piece of wire. In this case the coupling takes place not
- 65 at the voltage maximum but near the

node point. An earth is shewn diagrammatically in Figure 5e; this is not intended to represent an earth in the usual sense, (which can no longer be used without objection in this range of

70 frequency), but merely the connection of the corresponding circuit point with a metallic mass having a sufficiently great capacity towards earth. The plate-oscillator may also be coupled in the

75 radiation field, if desired even in a concentrated radiation field.

In order to carry out the tuning to one of the natural frequencies of the dipolar substance, the natural frequency of the plate-oscillator must be capable of being

80 tuned. In tuning it is preferable to distinguish between a coarse and a fine tuning. The coarse tuning is effected by altering the dimensions, especially the diameter, of the oscillator plates. In order to be able to tune to the dipolar substance, the natural frequency of which has a definite value at a given temperature and concentration, a corresponding

85 size of the plate oscillator must thus always be used. For example if the natural resonance of the dipolar substance lies at a wavelength of 30 centimetres, a diameter of 10 centimetres is necessary

90 in the case of circular plates, always assuming, that the fundamental oscillation of the oscillator is to be used, which yields a specially concentrated field. When the coarse tuning has been effected

95 by dimensioning, a fine tuning is still necessary to produce the resonance. In practice the fine tuning is most simply effected by altering the distance between the plates. The smaller this distance,

100 the greater the natural frequency. The plate oscillator is suitable for the production of concentrated electromagnetic alternating fields having a wavelength of about 5 millimetres to 10 metres.

105

Important technical effects result when the resonant electromagnetic excitations brought into action are modulated by high or low frequency. As examples the effects of modulation in the case of the

110 excitation of a plate-oscillator the cover of which is transparent and conducting are briefly described in the following. If the plate system be prepared so transparent by cathodic atomisation while

115 maintaining a good conductivity that only about 20 per cent. of light is absorbed or reflected, then by means of polarised light the configuration of the stationary wave field is portrayed by the orientation effect produced in the dipolar substance

120 which causes a double refraction. If the plate-oscillator be modulated by impressing a lower frequency tone oscillation, the wave train formed is imprinted

125

130

in all its detail on the dielectric and rendered visible in two dimensions by the described arrangement. The described apparatus may be used especially for
5 controlling strong beams of light.

Dated this 18th day of April, 1934.

J. Y. & G. W. JOHNSON,
47, Lincoln's Inn Fields, London, W.C.2,
Agents.

COMPLETE SPECIFICATION.

Improvements in Devices for Generating Electromagnetic Fields Oscillating with Quasi-optical Frequencies.

I, JAMES YATE JOHNSON, a British Subject, of 47, Lincoln's Inn Fields, in the County of London, Gentleman, do hereby declare the nature of this invention
10 (which has been communicated to me from abroad by Ternion Aktiengesellschaft, of Glarus, Switzerland, a Joint Stock Company organized under the Laws of Switzerland) and in what manner the same is to
15 be performed, to be particularly described and ascertained in and by the following statement:—

This invention relates to devices for generating electromagnetic fields oscillating with quasi-optical frequencies. By
20 a quasi-optical frequency is meant one corresponding (in the conventional sense) to a wave-length lying between a few tenths of a millimetre and three metres.

As explained in the co-pending application No. 32,555/32 (Serial No. 417,501) dipolar substances can be changed permanently (in the sense therein defined) by subjecting the substances to electromagnetic fields of sufficient intensity
30 oscillating with quasi-optical frequencies. The object of this invention is to provide means of obtaining the concentrated high frequency fields necessary for this and
35 other purposes.

According to a general physical principle, oscillations of great amplitude can be generated by using the phenomenon of resonance, that is to say, by exciting
40 a system by a force varying with a frequency equal to the frequency of one of its modes of free or natural oscillation, commonly called a natural frequency. This principle has been applied to electro-
45 magnetic oscillations both of quasi-optical and of lower frequency, usually for the purpose of timing and not in order to generate fields of great intensity. Some of the systems excited for this purpose
50 have been combinations of discrete condensers and self-inductances: others have been systems with distributed capacity and inductance, such as a pair of parallel wires (usually called Lecher wires) or a
55 pair of concentric cylinders. Further these systems having distributed capacity and inductance have been excited into

their higher modes of natural oscillation as well as into their fundamental mode.

It is well known that such systems
60 having distributed capacity and inductance have many modes of natural oscillation, analogous to the various modes of an acoustical vibrator. These modes depend on the constitution of the system
65 and on the conditions at its boundaries. Corresponding to any boundary condition there is one mode whose frequency is least; this is called the fundamental mode, while the other modes of higher
70 frequency are called higher modes. (In the acoustic analogy the higher modes are often called harmonics). Systems of parallel wires and concentric cylinders are often excited into the higher modes,
75 as well as the fundamental mode, of their natural oscillations.

When any system is excited into an electromagnetic oscillation, an electromagnetic field of the same frequency is
80 set up in its neighbourhood. But the fields of quasi-optical frequency obtained by exciting parallel wires or concentric cylinders are not generally sufficiently intense over a sufficient volume for the
85 purpose above-mentioned. It has now been found that suitable fields can be obtained by exciting into its higher modes of natural oscillation a system of opposed plates. Such a system of opposed
90 plates adapted to be excited into electromagnetic oscillations will be called a plate resonator. The simplest plate resonator shown in Figure 1 of the accompanying drawings, is a pair of
95 circular parallel conducting plates. But this is not the only form of plate resonator.

According to the invention a device for generating a concentrated electromagnetic field with quasi-optical frequency comprises a plate resonator and means independent of the resonator for
100 exciting it into one or more of its natural electromagnetic oscillations. The exciting means are to be deemed independent of
105 the resonator if and only if the circuit of which the resonator forms part would be capable of oscillation even if the resonator were removed from the circuit. Thus

exciting means consisting of a spark passing between the plates of the resonator are not to be deemed independent of the resonator; but exciting means consisting of a spark passing across the terminals of a circuit coupled to the resonator and capable of oscillation in its absence are to be deemed independent of the resonator.

10 The invention will now be described in detail under the following headings with reference to the accompanying drawings.

I. The natural oscillations of a plate-resonator. Figures 2, 3, 4, 5, 6, 7, 9, 10, 11, 12, 13, 14, 15, 16, 17, 18, 19, 20 are explanatory of the calculations. Figures 1 and 8a show simple forms of plate resonators; and Figure 8 b, c, d, e shows various forms of plate resonator, most of which are not easily amenable to calculation.

20 II. Constructions of plate resonators. Figures 8f, 21, 22, 23, 24 show some methods of construction.

III. Influence of the dielectric constant. Figures 33 and 34 are explanatory of the discussion.

IV. Influence of damping. Figures 35, 36, 37, 39 are explanatory of the discussion.

30 V. Excitation of the oscillations. Figures 25, 26, 27, 28, 29, 30, 31, 32 show various arrangements suitable for this purpose.

VI. Tuning the plate resonator. Figure 38 explains one of the objects of tuning; Figure 40 a method of achieving it.

VII. Use of the plate resonator. Figures 41-46 show arrangements of the dielectric suitable for modifying the distribution of the field. Figures 47, 48, 49, 50, 51 show apparatus suitable for applying the plate resonator to its primary purpose.

I. THE NATURAL OSCILLATIONS OF A PLATE RESONATOR.

45 In certain simple cases the oscillations of a plate resonator can be calculated. The course of the calculation and the meaning of some of the terms employed will be elucidated, if it is observed that there is a close, but not complete analogy, between the electrical oscillations of a plate resonator and the acoustical oscillations of a stretched membrane: electric intensity perpendicular to the surface

50 in the former corresponds to displacement from the position of rest in the latter.

The following notation will be used:—

- 60 d =distance between parallel plates forming the resonator.
- R =radius of circular plates.
- a, b =sides of rectangular plates.
- C =capacity of resonator.

E =electric intensity between the plates.
 F =current flowing along surface of the plate. 65

ϵ, μ =dielectric constant and permeability of medium between plates.

c =velocity of light.

$v=c/\sqrt{\epsilon\mu}$ (μ is always assumed to be unity). 70

t =time.

T =period of a mode of oscillation.

$\omega=2\pi/T$.

$\lambda=cT$ (the equivalent wavelength corresponding to T and ω). 75

ω_0 =value of ω for fundamental mode of oscillation.

ω_{pq} =value of ω for a higher mode characterised by integers p, q . $\omega_{rel.}=\omega_{pq}/\omega_0$ 80

It will be assumed that the plates are of infinite conductivity, so that E is always perpendicular to their surface, and that d is so small that dE/dn , where n is the normal to the surface, is everywhere zero. Then the problem is two-dimensional and d does not enter into the equations so long as ϵ and μ are constant between the plates. 85

(a) CIRCULAR PLATE. 90

The first case is that of circular parallel plates of radius R . Take cylindrical coordinates r, ϕ, z with origin at the centre of one plate, z being perpendicular to the surface. Then if Maxwell's equations are set up and solved, the familiar equation is obtained. 95

$$E=A_{pq}J_p\left[\omega_{pq}\frac{r}{v}\right].\cos(p\phi).\cos(\omega_{pq}t). \quad (1)$$

where J_p is the Bessel function of the first kind of the p th order. The integral suffix q corresponds to the q th root of this function. A_{pq} depends on the intensity of the excitation. 100

To proceed further the boundary conditions must be introduced. There are two main conditions corresponding respectively in the acoustic analogy to a clamped edge and a free edge. The case of the clamped edge above will be discussed thoroughly: it is defined by the boundary condition 110

$$E=0, \text{ when } r=R. \quad (2)$$

that is to say, the electric intensity is zero at the edge. Physically this represents loading the edge with a larger capacity, as will be explained later. 115

If x_{pq} is the q th root of $J_p=0$, the values of ω_{pq} are given by

$$\omega_{pq}=x_{pq}\frac{R}{v} \quad (\therefore)$$

The values of x_{pq} for various values of p, q are well known and have often been tabulated. Some of them are given in the second column of Figure 7, the values of p, q being indicated in the first column. The values are arranged in ascending order of magnitude. The 125

third column gives ω_{rel} , i.e. the ratio of the frequency of the higher modes (which are those for which either p or q is finite) to that of the fundamental mode $p=q=0$.

5 The variation of $J_p(x)$ with its argument x is shown in Figure 2 for some of the lower values of p .

As in the acoustical analogy, the various modes of oscillation are characterised by various configurations of the nodal surfaces, that is to say, the surfaces along which $E=0$. These are of course (1) cylinders $r=\text{constant}$, where r has a value for which

15
$$J_p\left(\omega_{rel} \frac{r}{v}\right) = 0 \dots\dots\dots (4)$$

and (2) planes $\phi=\text{const}$, where ϕ has a value for which

20
$$\cos(p\phi) = 0 \dots\dots\dots (5)$$

These surfaces intersect planes parallel to the plates of the resonator in nodal lines; these nodal lines, rather than the nodal surfaces, will be discussed in the sequel.

25 Figure 3 a, b, c shows E as a function of r across any diameter of the plate, for $p=0$ and $q=0, 1, 2$ respectively. In the fundamental mode $p=q=0$, the only nodal line is the edge $r=R$. In the higher modes one or more nodal lines appear on the surface; they are shown in Figure 4 a, b, c, which correspond to Figure 3 a, b, c. In these Figures (and in Figures 11, 12 13 below), E , represented by the dotted line, is the current; it is a maximum where E is a minimum and vice versa. These circular nodal lines appear in virtue of (4).

When p is finite, radial nodal lines appear in virtue of (5). These are shown in the right hand column of Figure 7, for the values of p and q thus tabulated.

Figures 5 and 6 show the distributions of charge on the surface of the plate; a nodal line always separates two areas over which the charge is of opposite sign. Figure 5 corresponds to $p=2, q=3$, Figure 6 to $p=2, q=0$. This last figure is drawn so as to show that the radial nodal lines do not really extend completely across the plate; the point $r=0$ is avoided and in its neighbourhood the lines are hyperbolic.

Figure 9 is a nomogram giving the relation between the corresponding wavelength λ for various modes of a plate-resonator of radius R . To obtain λ a straight line is drawn through the appropriate value of R on the right hand scale and the appropriate values of p, q , on the centre scale; the intersection of the line with the left hand scale gives λ . Thus for the fundamental mode ($p=q=0$) of a resonator with $R=10$ cm., $\lambda=26.2$ cm., and $\omega=1.14 \times 10^9$ Hertz. For the same resonator in the higher mode $p=2, q=0$, $\lambda=12.2$ cm.

The other main boundary condition corresponds in the acoustical analogy to a free edge. It is defined by

70
$$dE/dr = 0 \text{ when } r=R \dots\dots\dots (6)$$

and means physically that the edge is far from all conductors. This condition will not be discussed further for the circular plate.

(b) Rectangular plate.

The other case amenable to calculation is a pair of parallel rectangular plates having sides of length a, b . Cartesian coordinates are taken with the origin at a corner and Z perpendicular to the plate. With the same assumptions the same meaning of E the equation corresponding to (1) is

80
$$E = A_{p_1} \sin(\omega t + \beta) \left[U \sin \frac{\pi p_1 x}{a} \sin \frac{\pi q_1 y}{b} \pm V \sin \frac{\pi p_2 x}{a} \sin \frac{\pi q_2 y}{b} \right] \dots\dots\dots (7)$$

where p_1, q_1, p_2, q_2 are any finite integers, satisfying the condition

85
$$b^2 p_1^2 + a^2 q_1^2 = b^2 p_2^2 + a^2 q_2^2 \dots\dots\dots (8)$$

$$\omega_{p_1} = \pi v \sqrt{\frac{p_1^2}{a^2} + \frac{q_1^2}{b^2}} \dots\dots\dots (9)$$

$$= \pi v \sqrt{\frac{p_2^2}{a^2} + \frac{q_2^2}{b^2}}$$

90 The configurations of the nodal lines depend on the value of v/u . When $v/u=0$ some of them are given by Figures 11-16, which need no further explanation in view of what has been said about Figures 3-6. The values of p, q are

given above each Figure. The fundamental mode is now that for which $p=q=1$; it is shown in Figure 11; the other figures show higher modes.

The effect of other values of v/u is shown in Figure 17. All configurations in Figure 17 have $p=1, q=2$; in 17a, $v/u=0$, in 17d $v/u=1$, in 17e $v/u=\infty$, in 17b and 17c v/u is fractional.

The periods and corresponding wavelengths of the various modes of oscillation can be obtained from (9). Figure 10 is a nomogram corresponding to Figure 9 for symmetrical modes in which $v/u=0$. The right hand scale gives a ; an intermediate line corresponds to each value of $k=a/b$; along these intermediate lines the values of p, q are marked. There is

a central working line drawn thicker. The point on the line for the appropriate values of a is projected horizontal on to this central line; a straight line through the value of a on the right hand scale and this projected point then cuts the left hand scale at the corresponding λ . Thus from the two lines drawn it will be seen that, for $a=20$ cm., $b=10$ cm.,

the fundamental mode, $p=q=1$ gives $\lambda = 18$ cm.; whilst the mode $p=1, q=3$ gives $\lambda=6.6$ cm.

Equation (7), like equation (1), refers to a clamped edge, i.e. $E=0$ on the boundary. For a free edge, when the variation of E perpendicular to an edge is zero everywhere on the boundary, the appropriate equation is

$$E = A_p \sin(\omega t + \beta) \left[U \cos \frac{\pi p x}{a} \cos \frac{\pi q y}{b} \pm V \cos \frac{\pi p x}{a} \cos \frac{\pi q y}{b} \right] \quad (10)$$

where (8) and (9) still hold. Figures 18, 19, 20 corresponding to Figures 11, 12, 13, show the configuration of the nodal lines when $v/u=0$ for $p=q=1, p=2, q=1, p=3, q=1$. The fundamental mode is again $p=q=1$; it is important to notice that in this case, when the edge is free, there are nodal lines on the centre, and not merely at the edge, even in the fundamental mode. The fundamental mode is therefore not always characterised by the absence of nodal lines on the surface.

Perfectly conducting parallel circular and rectangular plates are the only forms of plate-resonators whose natural frequencies are easily calculated. But other forms are permissible according to the invention. A few other permissible geometrical forms are illustrated in Figures 8 b, c, d, e.

II. CONSTRUCTION OF PLATE-RESONATORS.

The plates of the resonator may be of solid metal. The assumption of perfect conductivity can never be accurately true; but it will be nearly true if copper, silver or aluminium is used. If a lower conductivity is required (for a reason to be discussed presently) iron or nickel may be used, or even an electrolyte, as shown at Figure 8f.

For some purposes it is desirable that the plates should be transparent. Thin films of gold, silver, platinum deposited on glass may be used. The thinner the film, the less the absorption of light, but the greater the electric resistance.

Wire gauze can also be used for the plates. One form of plate resonator using wire gauze is shown in Figure 21; the gauze 7 is clamped between metal rings 5, 6 by screws 8. In order to obtain good contact between the wires at their intersections, the wires at these places may be united, for example by electroplating. The substitution of gauze for a continuous plate alters somewhat the natural frequencies. This is doubtless for the reason illustrated in Figure 22. Current can flow freely only along the directions marked I, II; if it has to flow in an intermediate direction, it can only

follow a zig-zag line, such as is shown at III. The path of the current is therefore longer than it would be if the plate were continuous. Hence, as might be expected, the effective radius R in (3) is greater than the actual radius. The increase in R is not susceptible of exact calculation, but it is usually less than that calculated on the assumption that the current follows the path III and agrees more nearly with that calculated from a path such as IV.

A gauze plate resonator may consist of two gauze plates (as shown at a in Figure 23) or a gauze plate and a continuous plate (as shown at b) or one gauze plate in air and another in another medium (as shown at c).

Since oscillations with a "free" edge may be greatly disturbed by stray fields, it is generally preferable to use the oscillations with a "clamped" edge. The method of "clamping", or introducing capacity at the edge, is shown in Figure 24. Here the plates 1, 2 of the resonator with their coupling conductors 3, 4 (to be discussed below) are enclosed in a conducting cylinder 9, which may be of metal or silvered glass. The distance between the edge and the cylinder may be about $R/10$. In order to fix the position of the nodal diameters, a metal block 10 may be fixed to the cylinder at one point between the plates; it should not extend so far inwards as to cut a line joining the edges. A nodal diameter will then terminate in the neighbourhood of the block, or at least will be deflected at its end towards that neighbourhood. By the use of several blocks of this kind the configuration of the nodal lines may be influenced; circles may be distorted into ellipses and so on. The block may be fastened to the edge of the plate rather than to the cylinder. If rods of regularly increasing length are fixed round the edge of the plate along radii, configurations with spiral nodal lines can be produced.

III. INFLUENCE OF THE DIELECTRIC CONSTANT.

If the medium between parallel plates

is homogeneous, ϵ enters only by determining v in equation (3) and d is without influence on ω so long as the assumptions stated above are true. But if the medium between parallel plates is made up of $N+1$ layers each of thickness d_n dielectric constant ϵ_n ($n=0$ to N), the resultant dielectric constant $\epsilon_{res.}$ determining v , is given by

$$\epsilon_{res.} = \frac{d}{\sum_n d_n / \epsilon_n} \quad (11);$$

consequently d partly determines ω , T and λ .

Suppose then we have an arrangement, such as is shown in Figure 34 consisting of two circular metallic plates of radius R , 112, 113, between which lies a trough having side plates 114, 115 abutting on a ring 116 and filled with liquid 111. The thickness of the plane layer of liquid is d_1 and its dielectric constant ϵ_1 , the total thickness of the side plates is d_2 and the dielectric constant of their material (e.g. glass) $\epsilon_2 > 1$ the distance between the plates is d , so that the third layer, air, of dielectric constant 1, has a thickness $d - d_1 - d_2$. $\epsilon_{res.}$ for the combination can be calculated from (11) and can be altered by changing d as well as by changing ϵ_1 by altering the composition and/or temperature of the liquid.

Variation of $\epsilon_{res.}$ and therefore of λ , by means of d is useful for tuning the resonator to a given frequency. For this purpose the nomogram shown in Figure 33 may be employed. The right hand scale gives R . The intermediate lines, each corresponding to a mode of oscillation $J_n(x)$, bears scales of $\epsilon_{res.}$. The left hand scale gives λ . To determine the value of d corresponding to a given λ , we join this λ to the appropriate R by a straight line: from the point where this cuts the thick central line (not corresponding to any $J_n(x)$), we draw a horizontal line: this cuts the appropriate line for $J_n(x)$ at the right value of $\epsilon_{res.}$. Thus, the line marked lm^1 , shows that to excite oscillations for which $\lambda = 10$ cm., in circular plates of radius 8.0 cm., the mode being that of $J_0(x_{02})$, $\epsilon_{res.}$ must be about 3. If d_1 , ϵ_1 , d_2 , ϵ_2 are fixed, we can draw a curve from (11) relating $\epsilon_{res.}$ and d , and thus determine the appropriate value of d . (The lines marked lm and st in Figure 33 correspond to other values of R and λ).

IV. INFLUENCE OF DAMPING.

In the calculations of Section I the system was assumed to be non-dissipative. Actually there are three main sources of dissipation:—(1) ohmic conductivity of the dielectric separating the plates, (2) viscosity opposing the

orientation of dipoles in the dielectric (this is discussed in the co-pending application 32,555/32, Serial No. 417,501), (3) resistivity of the material of the plates.

In virtue of the dissipation, the oscillations of the plate resonator will be damped and will be characterised by a damping coefficient K defined (as usual) by the statement that, during a single period the amplitude of the oscillations decreases in the ratio 1 : $e^{-2\pi K}$.

We may write

$$K = a(K_1 + K_2) + K_3 \quad (12)$$

where K_1 , K_2 , K_3 depend on the ohmic conductivity of the dielectric, its viscosity and the resistivity of the plates. The quantity a is introduced, because the physical nature of K_1 , K_2 is different from that of K_3 . It would be possible to calculate K_1 , K_2 , K_3 , a , in terms of these properties and of R and d . But such a calculation would not be helpful. However the general effect of these sources of dissipation can be appreciated by means of Figures 35, 36. If we suppose the dissipation represented by K to be concentrated in the dielectric of Figure 34, the medium between the plates is equivalent to the network of Figure 35, the condenser C_3 representing the non-dissipative part of the medium and C_1 , shunted by an ohmic resistance R_1 , representing the dissipation part. This again, by a known transformation, is equivalent to the network of Figure 36, being a simple condenser $C_{res.}$ shunted by a resistance $R_{res.}$. $C_{res.}$ and $R_{res.}$ are functions of K_1 , K_2 , K_3 , a .

The presence of the equivalent network of figure 36 connecting the plates of the resonator has two effects familiar from the general theory of oscillations. First it broadens the single resonance frequency into a resonance band, so that the resonator can be excited, not only by a frequency equal to its natural frequency, but also by a frequency differing somewhat therefrom. This effect is shown in Figure 37, where the ordinate measures the amplitude of the oscillations excited in the resonator by frequencies corresponding to the abscissæ. Two curves are shown, one for a greater and one for a lesser value of the equivalent damping coefficient K . The broad resonance band produced by damping can, of course, be used to avoid the need for exact tuning.

The second effect is a shift of the natural frequency. This may be represented by an effective dielectric constant ϵ_K determining v , and thus ω and λ , as well as of K_1 , K_2 , K_3 , a , ϵ_1 . When the damping is large, ϵ_K depends little on ϵ_1 . For this case Figure 39 gives

the value of d corresponding to ϵ_k , when d_1 , the layer of dielectric in which all the dissipation is supposed to be concentrated, has the value marked against the curves.

It is to be observed that if a plate oscillator is excited by applying to it suitably a voltage $E^1 = E_0 \cos \omega_{pq} t$, A_{pq} in equations (1) and (7) which measures the amplitude of the resulting oscillations will be given by

$$A_{pq} = E_0 \frac{1}{2k} \quad (13)$$

This result is, of course, a commonplace in the general theory of oscillations.

V. EXCITATION OF THE OSCILLATIONS.

The plate resonator can be excited by any high frequency generator, for instance a valve generator, which can be tuned accurately to the natural frequencies of the resonator. Since the damping of the resonator is usually small, the coupling between generator and resonator must be loose. Appropriate coupling means are shown in Figure 25. Here parallel conductors 45, 46 are fed from the valve oscillator 54. They carry small spheres 47, 48. Opposite to these spheres are similar small spheres 49, 50 at the ends of short conductors fixed to the back of the resonator plates 51, 52. The capacity between the spheres 47, 48 on the one hand and spheres 49, 50 on the other provides the coupling. The condenser 53 bridging the ends of the parallel conductors is placed so that 47, 48 lie at a voltage loop or anti-node as shown by the dotted lines. Of course if less than the maximum excitation is required, they may lie elsewhere than at a loop.

The spheres 49, 50 need not be fixed to the centres of the plates as shown in Figure 25, they may be eccentric as shown in Figure 26. The parallel conductors 65, 66, terminate in a conducting bridge 73. The conductors again carry spheres 63, 64 opposite the spheres 61, 62 on the plates 59, 60.

If closer coupling is required than is provided by the adjacent spheres, because the plate resonator is highly damped, one of the methods shown in Figures 27, 28, 29 may be adopted. In Figure 27, the coupling means 55, 56 is a sphere on the plate surrounded by a ring fed by the generator; in Figure 28 the coupling means 57, 58 are opposed plates, instead of opposed spheres; in Figure 29 plates 89, 90 lie close against the resonator plates 87, 88 and are metalically connected to the generator by leads 85, 86. In this last method the point of coupling may be easily moved over the surface of the plates.

Figures 30, 31, 32 show a method of

exciting the oscillations with a "clamped" edge. In Figure 30 the circular plates 94, 95 are enclosed in the cylinder 92; a side tube 91 acting as one of the leads (corresponding to 45, 46 in Figure 25) is connected to 92 and carries a small sphere opposite the edge of 95; a lead 93 concentric with 91 carries a small sphere opposite the edge of 94. In Figure 31 the coupling is inductive; a loop 96 with leads 97, 98 extends between the plates. Figure 32 shows an arrangement suitable with larger plate resonators. The leads are a tube 99 forking into two branches 100, 101 and a concentric wire; they are tuned by the reflector bridges 102, 103. The plates are coupled to the wire by means of the leads 104, 105 ending in small spheres. A trombone-like portion 108 enables the length of the leads to be adjusted and thus the loop of the field along the leads to be brought opposite to 104, 105 for various frequencies. Alternatively, if the frequency is constant, 104, 105 can be made to coincide with points between a loop and a node and the strength of the excitation thus varied.

VI. TUNING THE PLATE-RESONATOR.

As was stated above one of the chief uses of a plate resonator is the alteration of the properties of dipolar substances by exposure to an electromagnetic field of quasi-optical frequency. In such substances the dielectric constant varies with λ in some such manner as that shown in Figure 38. There is a rapid change of ϵ between the wave-lengths λ_1 and λ_2 ; in this region lies a characteristic period or frequency of the substance, which must coincide with the period or frequency of the field, if the desired effects are to be obtained. It is important therefore to tune the resonator to this period or frequency.

For this purpose use may be made of the alteration of the optical double refraction of a dipolar substance when exposed to a field of quasi-optical frequency. Apparatus suitable for this purpose is shown in Figure 40. The plates 120, 121 of the resonator are coupled by the conductors 122, 123 to the parallel conductors 124, 125 fed by the valve generator 126 and tuned by the bridge 127; or it can be excited by other means described above. The distance between the plates can be adjusted accurately by means not shown. Between the plates lies a trough 128 containing a dipolar substance, whose temperature can be varied by means of the heating coils 129 enclosed with the plates and the trough in the casing 130 which serves as a screen. The plates must be partially transparent, thus they may be thin films on glass or wire gauze,

as described above.

The optical parts include the source 137, the condensing lenses 131*a*, 131*b*, 132*a*, 132*b* adjusted so that the beam 5 converges through the polariser 133, passes as a parallel beam through the plates and trough, diverges through the analyser 134 and finally reaches the observing screen 138. 135, 136 are 10 quarter-wave mica plates to produce circularly polarised light; they may or may not be present. In place of the incandescent source 137 shown, it may be 15 such as a mercury vapour lamp; for the change of double refraction is usually greatest in the ultra-violet. Glass must then be replaced by quartz in the optical path; a fluorescent screen of matt 20 uranium glass may be used at 138.

If, in the absence of the quarter-wave plates, the polariser and analyser are set to extinction and the field of quasi-optical frequency then applied to the plates 120, 25 121, a pattern will appear on the screen 138 determined by the configuration of the nodal lines. For the double-refraction depends on the strength of the field; it will be less along the nodal lines than 30 elsewhere. From the pattern seen it is therefore possible to deduce the mode of oscillation and thus the frequency. If the plates 135, 136 are used with the incandescent source 137, the pattern will 35 appear in colour.

If the frequency of the generator is modulated, combination frequencies appear which produce varying extremely complicated nodal configurations on the 40 screen, which can be observed visually or by photoelectric cells and thus audibly.

VII. USE OF THE PLATE-RESONATOR.

In order that a plate resonator may 45 be used for the purpose mentioned at the beginning of the last section, the substance whose energy content is to be changed must be introduced between the plates. If it is a liquid, it will be con- 50 tained in a trough. There are certain advantages, which will now be pointed out, in making the trough lens-shaped, as shown in Figures 41—46. In all these 55 Figures, the substance to be acted upon is supposed to be contained in the central parallel sided portion (144 in Figure 41; marked ϵ , in Figures 43, 45). The lens-shaped portions (142, 143 in Figure 41, marked ϵ_1 in Figures 43, 45) are of glass 60 or are filled with a liquid of high dielectric constant. 140, 141 (and similar parts in the other Figures), are the plates of the resonator.

In the first place, the lens-shaped trough, 65 if equivalent to a condensing lens, can be

used to replace lenses 132*a*, *b* in Figure 40. But, more important, it can be used to influence the distribution of the field.

It follows from (1) that if $\epsilon \propto \frac{1}{r^2}$ so that $v \propto r$, E is independent of r and the field is uniform along any radius. If ϵ is identified with ϵ_{res} in (11), this result can be obtained by giving a suitable shape to the boundary between the medium of higher dielectric constant ϵ_2 and that of lower dielectric constant ϵ_0 ; such a boundary is shown in Figure 42, where 145, 146 are the resonator plates whose distance is d ; d_2 is the thickness of the medium ϵ_2 at any r . Since the boundary cuts the plates at m , n , this boundary is not practicable; but an approximation to it, such as is shown in Figure 43, will make the field nearly independent of r . Alternatively if the lens is bi-concave, as shown in Figure 44, the field is concentrated at the centre of the plates. Other lens systems, having effects similar respectively to those of Figures 43, 44, are shown in Figures 45, 46. Here the lenses do not form the sides of the trough, but are attached to the plates.

Figures 47, 48 show two elevations at right angles of an apparatus suitable for subjecting a dipolar liquid to the field of a plate-resonator.

The double-walled cylindrical casing 201, 202 is closed at either end by the insulating plates 203, 204. It contains 100 the plates 205, 206 supported on insulating rods sliding in sleeves 207, 208 borne on the plates 203, 204; their distance can be varied by means of micrometer screws 209, 210. Energy is supplied to 105 the plates by the branched conductors 211, 212, whose ends are coupled to the plates as shown at 213, 214. A trough 215 is supported between the plates by the adjustable insulating supports 216 sliding 110 in the sleeves 217. Electrical heating elements 218 are arranged within the casing to control its temperature.

When the substance has to be cooled quickly, in order to "freeze" it (as described in application No. 32,555/32, (Serial No. 417,501)) a low boiling point liquid is introduced in the form of spray by the pipes 220, 221, 222 terminating in nozzles; air is injected through the 120 pipes 223, 224, 225 to promote evaporation. The air and vapour is carried away by the tube 227. 226 is a door with an observation window. Steady high tension (for the purpose explained in application No. 32,555/32, (Serial No. 125 417,501)) is supplied through chokes 228, 229. The arrangement shown at 230 enables the apparatus to be swung into

the vertical position.

When the dipolar substance is solid (for example a food stuff to be preserved) the arrangements shown in Figures 49—51 are suitable. Here the plates of the resonator are rectangular.

In Figure 49 the plates 231, 232, 233, separated by insulating distance pieces 234, form shelves on which the material may be placed. Means for excitation are shown in Figures 50, 51 which are so similar to Figure 25 that no further description is needed. In Figure 51 the leads are concentric and similar to those shown in Figure 50.

Having now particularly described and ascertained the nature of our said invention and in what manner the same is to be performed, we declare that what we claim is :—

1. A device for generating a concentrated electromagnetic field of quasi-optical frequency comprising a plate resonator and means independent of the said resonator for exciting it into one or more of its natural electromagnetic oscillations.

2. A device according to Claim 1 in which the edges of the said resonator are so far from other conductors that the modes of its natural oscillations are substantially those characteristic of a free edge, as hereinbefore defined.

3. A device according to Claim 1 in which the edges of the said resonator are so closely surrounded by a conductor that the modes of its natural oscillations are substantially those characteristic of a clamped edge, as hereinbefore defined.

4. A device according to Claim 3 in which the surrounding conductor approaches the edge more closely at some points than at others, whereby nodal lines are caused to terminate at the points of nearest approach, or to be distorted towards those points.

5. A device according to Claim 1, 2, 3 or 4 in which the plate resonator consists of one or more pairs of parallel plates, circular or rectangular.

6. A device according to Claims 1, 2, 3 or 4 in which one or more plates of the resonator consists or consist of a metal film on a badly conducting support.

7. A device according to Claims 1, 2, 3, or 4 in which one or more plates of the resonator consists or consist, in part at least, of wire gauze.

8. A device according to Claim 7 in which the wires constituting the gauze are joined conductively at their intersections.

9. A device according to Claims 1, 2, 3, or 4 in which one or more of the plates of the resonator consists or consist of a

layer of electrolyte.

10. A device according to any preceding claim in which there are between the plates of the resonator a plurality of substances all of which have not the same dielectric constant.

11. A device according to Claim 10 comprising means for varying the distance between the said plates whereby the resultant dielectric constant, as hereinbefore defined, can be varied.

12. A device according to any of Claims 1—11 in which the said means for exciting the said resonator comprise a valve generator tuned to the frequency or frequencies of one or more of the natural oscillations of the resonator.

13. A device according to Claim 12 in which the said valve generator is capacitatively coupled to the resonator by means of one or more conductors each of which is connected to a plate of the resonator and approaches, but does not touch, one of a pair of conductors connected to the output terminals of the valve generator.

14. A device according to Claims 3 and 13 in which the said pair of conductors are a tube and a conductor concentric with the said tube.

15. A device according to Claim 14 in which the said tube and concentric conductor have a trombone-like part, whereby their effective length can be varied.

16. A device according to Claim 12 in which the said valve generator is inductively coupled to the resonator by a loop, passing between the plates of the resonator, with its ends connected to the terminals of the valve generator.

17. A combination of a device according to any preceding claim with optical apparatus comprising a source of radiation, a polariser and an analyser for said radiation, whereby the change of double refraction of a medium between the plates of the resonator with the intensity of the field between them indicates the position of the nodal lines.

18. A combination according to Claim 17 in which radiation emitted from the said source is in the ultra-violet region of the spectrum.

19. A combination of a device according to any of Claims 1—16 with means for introducing between the plates of the resonator a dipolar substance whose energy content can be changed by exposure to an electromagnetic field varying with quasi-optical frequency.

20. A combination according to Claim 19 comprising one or more lens-shaped bodies of dielectric constant greater than that of air arranged between or fastened to the plates as and for the purpose

hereinbefore described.

21. A combination according to Claim 20 in which the said lens-shaped body or bodies forms the side or sides of a trough
5 containing the dipolar substance.

22. A combination of a device or a combination according to any preceding claim with means for applying a constant potential between the plates of the plate
10 resonator.

23. Apparatus for subjecting a dipolar substance to an electromagnetic field of quasi-optical frequency substantially as described with reference to any of Figures 47—51.

15

Dated the 18th day of April, 1934.

For the Applicant,
J. Y. & G. W. JOHNSON,
Chartered Patent Agents.

[This Drawing is a reproduction of the Original on a reduced scale.]

Fig. 1

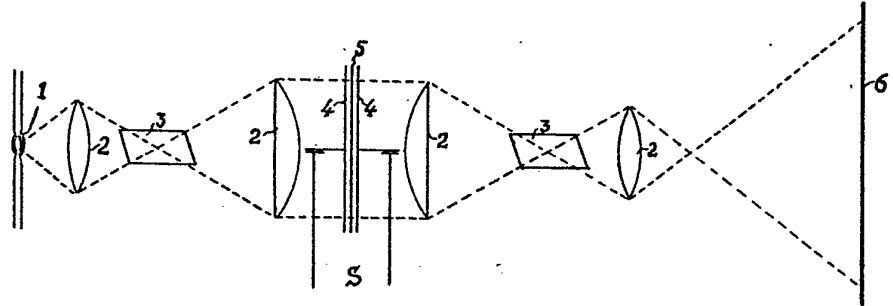

Fig. 2 a

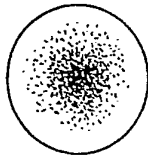

Fig. 2 b

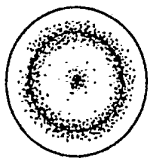

Fig. 2 c



Fig. 2 d



Fig. 3 a

Fig. 3 b

Fig. 3 c

Fig. 3 d

Fig. 3 e

Fig. 3 f

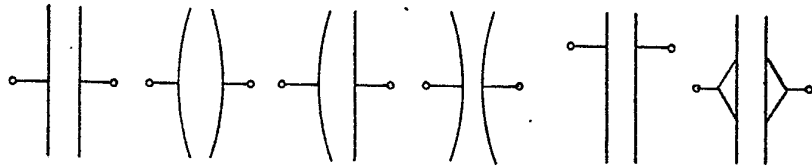

Fig. 4 a

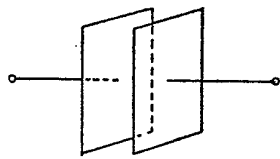

Fig. 4 b

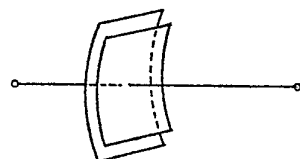

Fig. 5 a

Fig. 5 b

Fig. 5 c

Fig. 5 d

Fig. 5 e

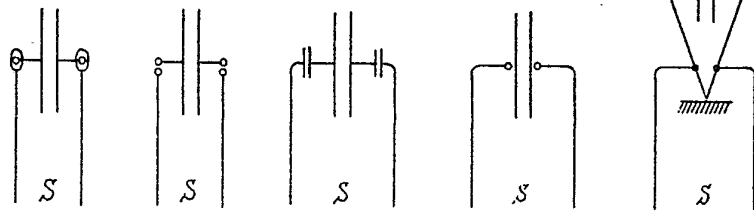

[This Drawing is a reproduction of the Original on a reduced scale.]

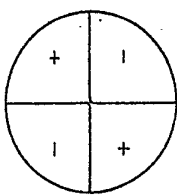
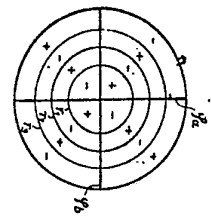
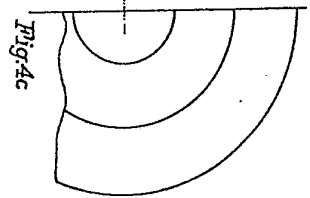
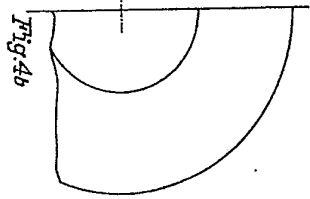
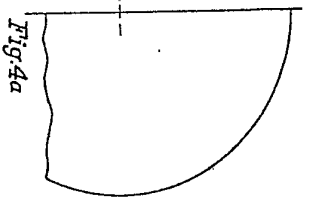
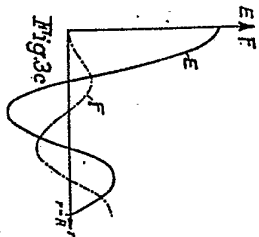
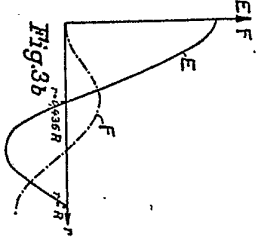
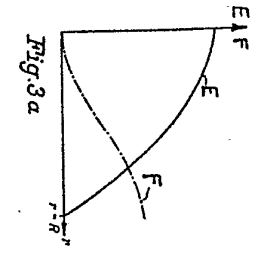
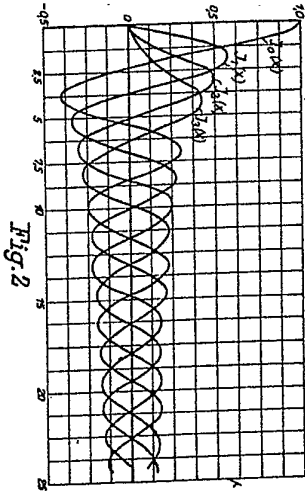
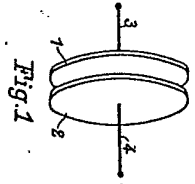

$J_p(K_{pq})$	Xpq	$\omega_{p,q}$	
$J_0(K_{00})$	2,405	1	
$J_1(K_{10})$	3,892	1,59	
$J_2(K_{20})$	5,135	2,74	
$J_0(K_{01})$	5,520	2,30	
$J_3(K_{30})$	6,379	2,65	
$J_1(K_{11})$	7,016	2,92	
$J_4(K_{40})$	7,586	3,16	
$J_2(K_{21})$	8,417	3,5	

Fig. 6

Fig. 7

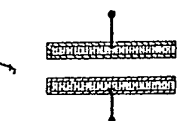
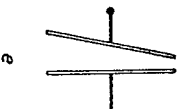
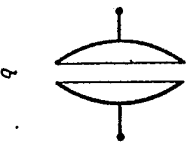
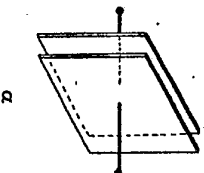

Fig. 8

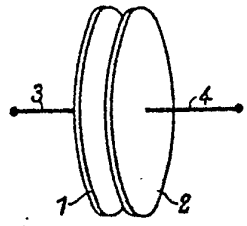

Fig. 1

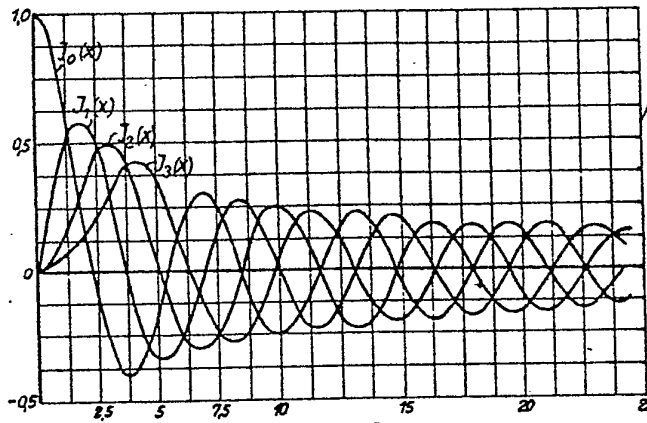

Fig. 2

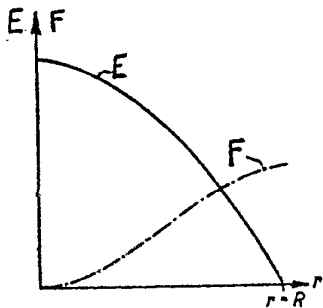

Fig. 3a

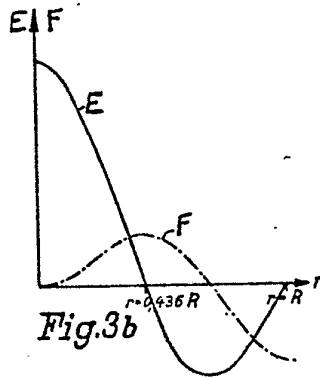

Fig. 3b

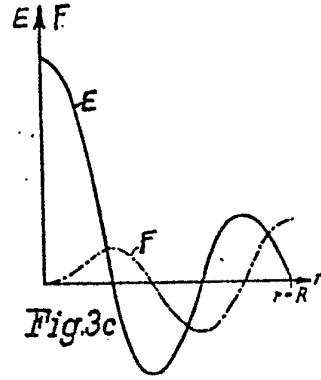

Fig. 3c

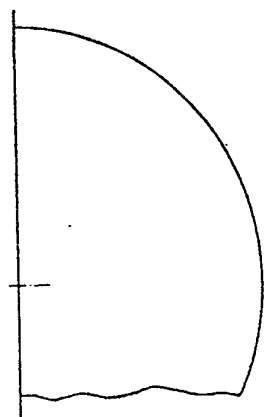

Fig. 4a

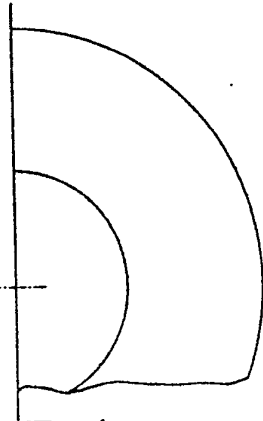

Fig. 4b

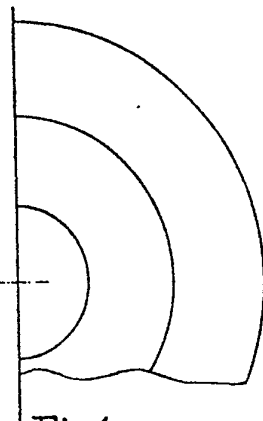

Fig. 4c

[This Drawing is a reproduction of the Original on a reduced scale.]

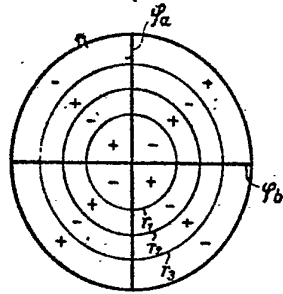

Fig. 5

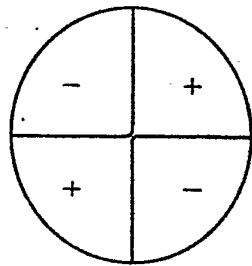
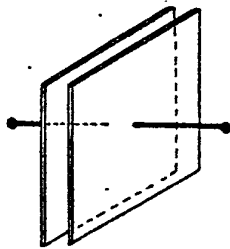

Fig. 6

$J_p(X_{pq})$	X_{pq}	$\omega_{rel.}$	
$J_0(X_{00})$	2,405	1	
$J_1(X_{10})$	3,832	1,59	
$J_2(X_{20})$	5,135	2,74	
$J_0(X_{01})$	5,520	2,30	
$J_3(X_{30})$	6,379	2,65	
$J_1(X_{11})$	7,016	2,92	
$J_4(X_{40})$	7,586	3,16	
$J_2(X_{21})$	8,417	3,5	

Fig. 7



a

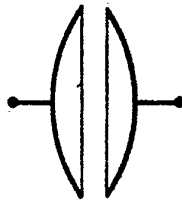

b

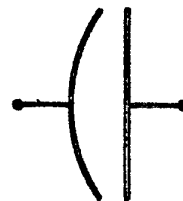

c

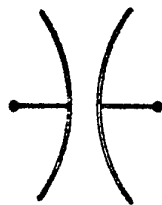

d

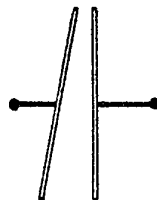

e

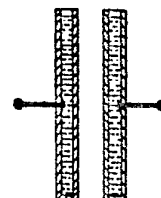

f

Fig. 8

[This Drawing is a full-size reproduction of the Original.]

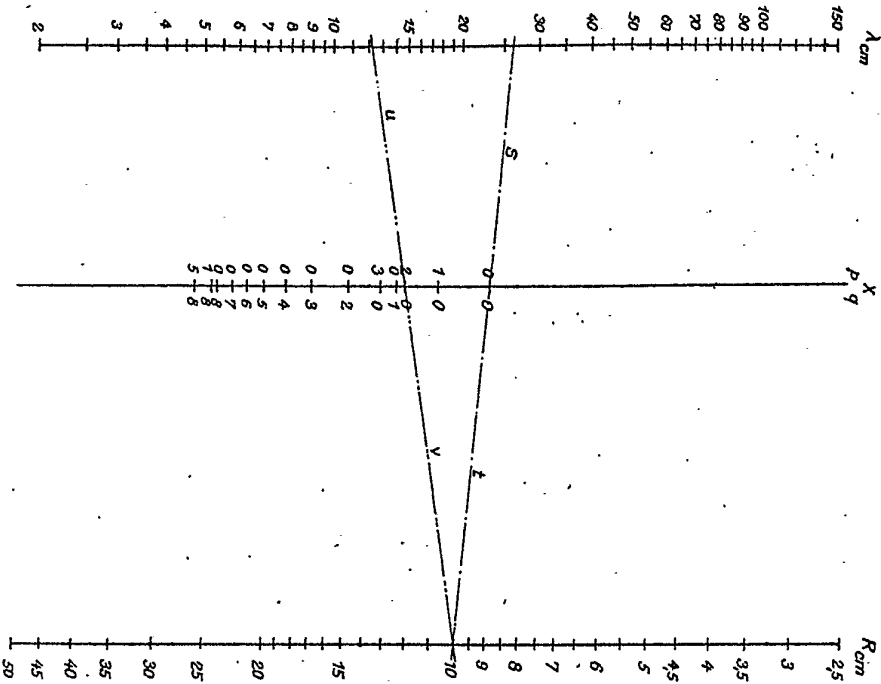

Fig. 9

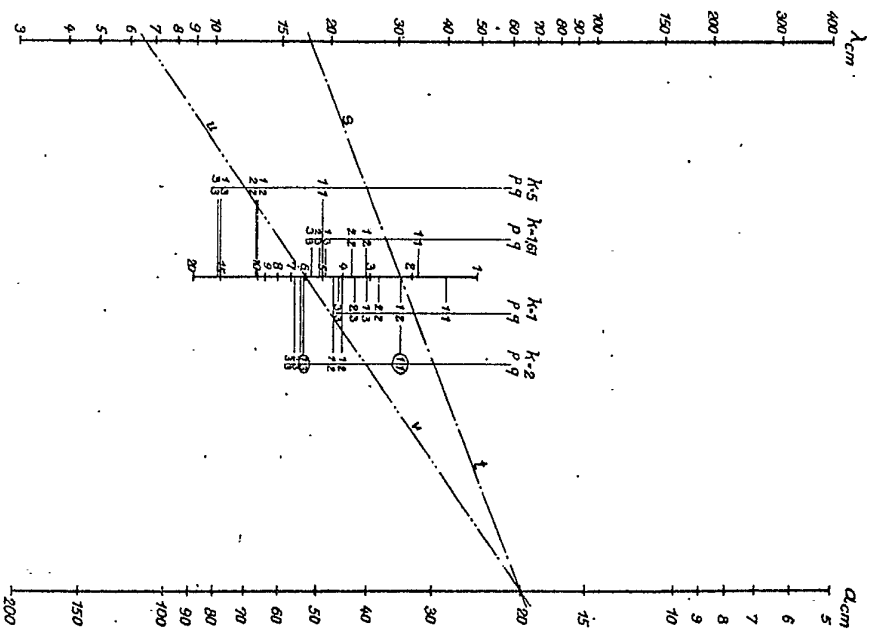

Fig. 10

[This Drawing is a full-size reproduction of the Original.]

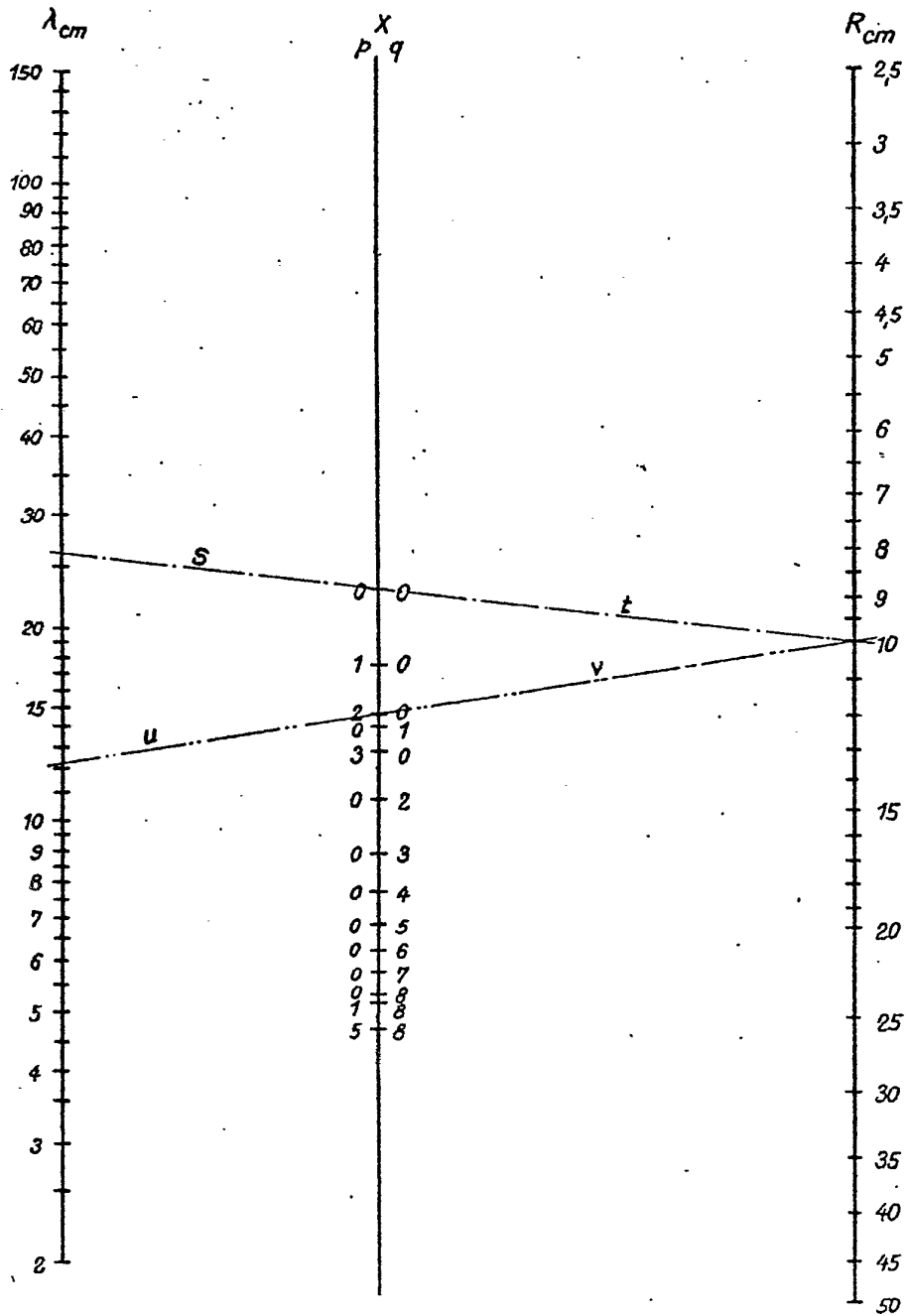

Fig.9

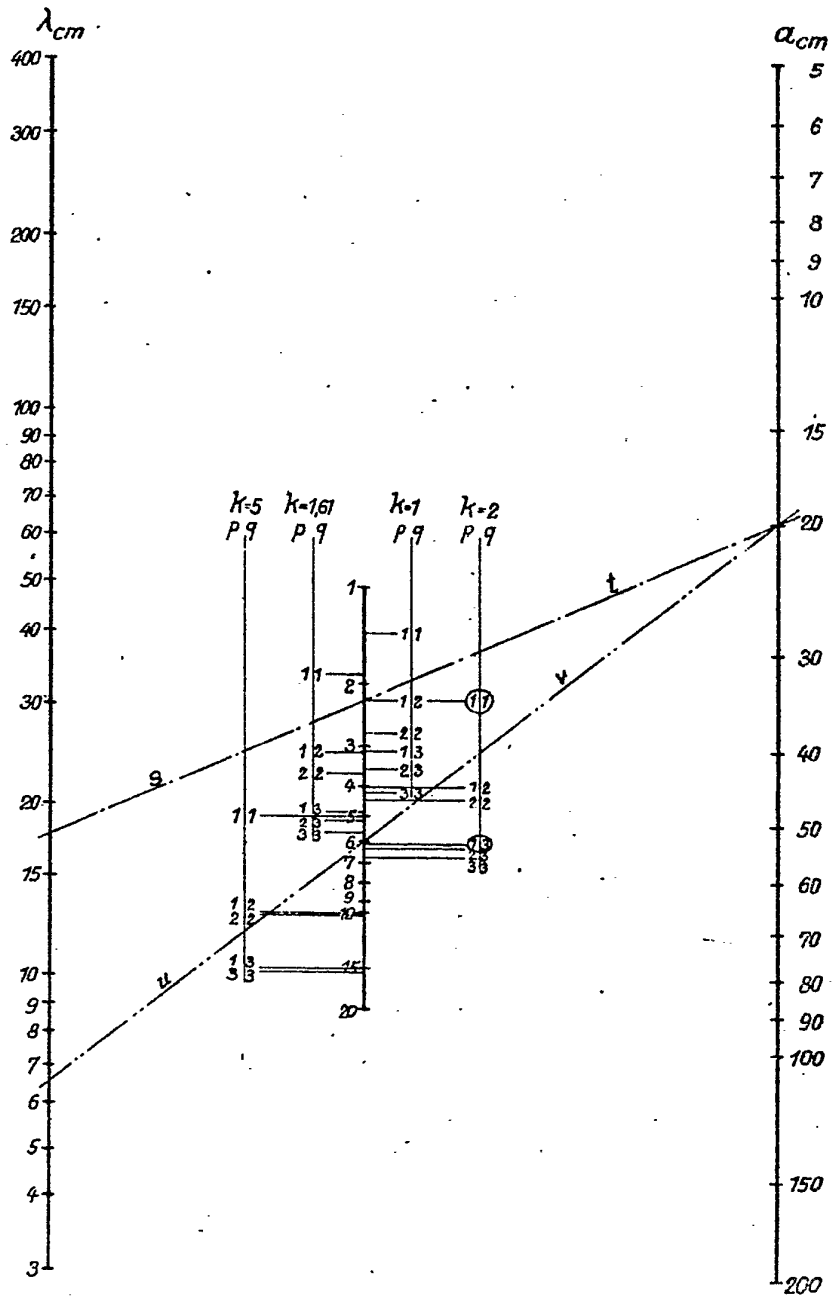
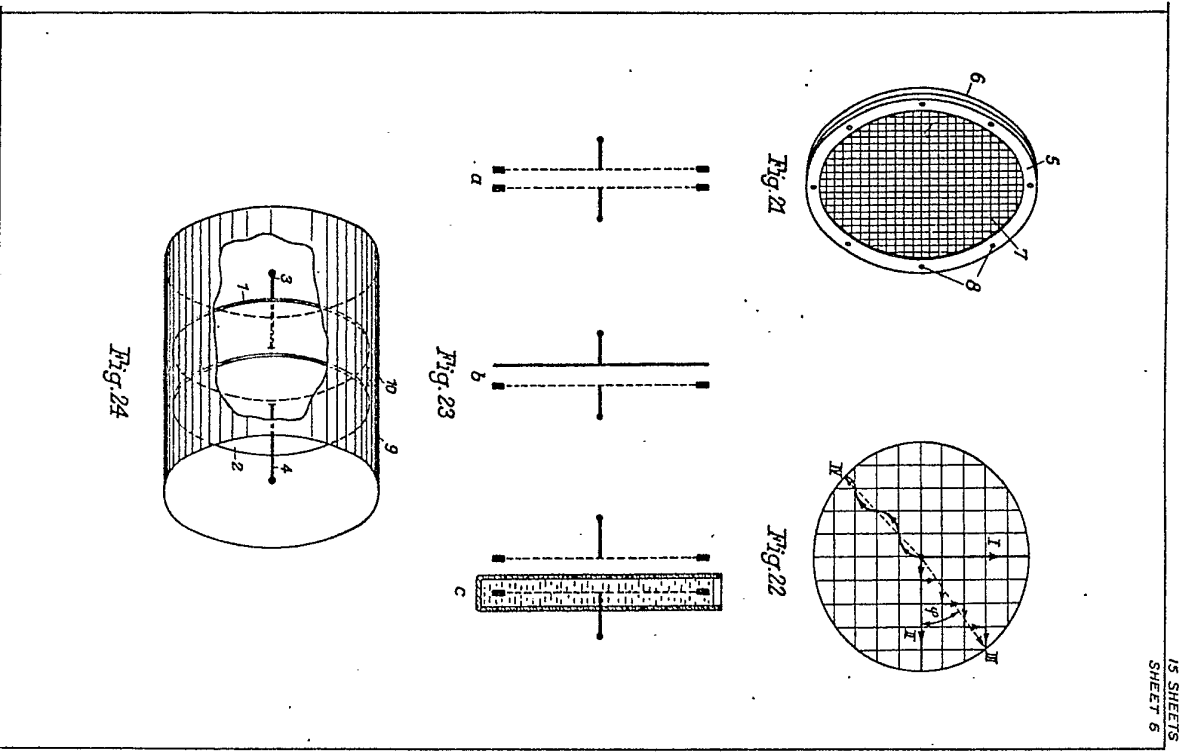
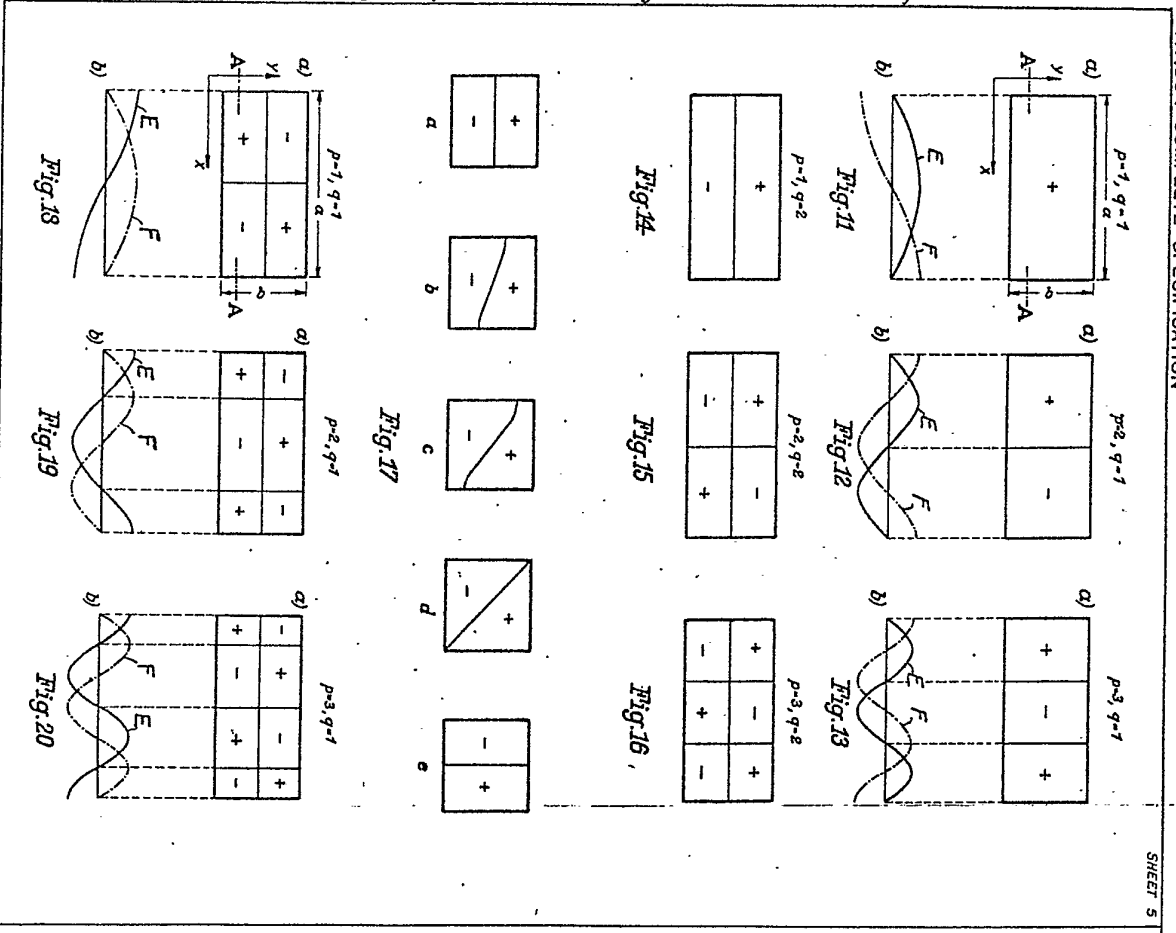

Fig. 10

[This Drawing is a reproduction of the Original on a reduced scale.]



[This Drawing is a reproduction of the Original on a reduced scale.]

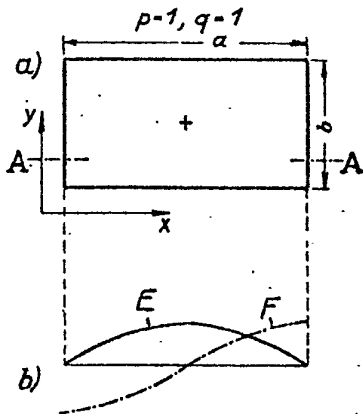

Fig.11

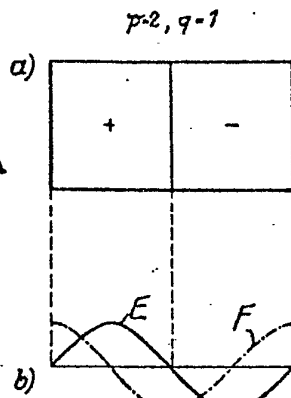

Fig.12

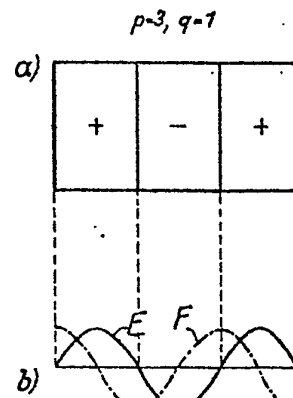

Fig.13

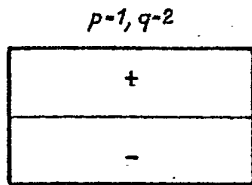

Fig.14

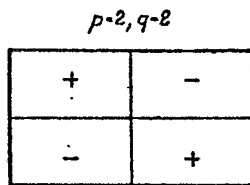

Fig.15

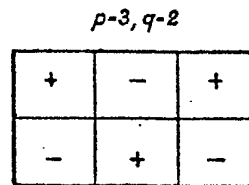

Fig.16

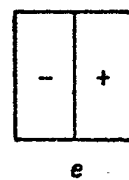
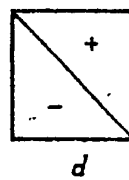
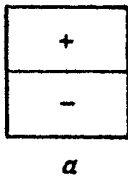

Fig.17

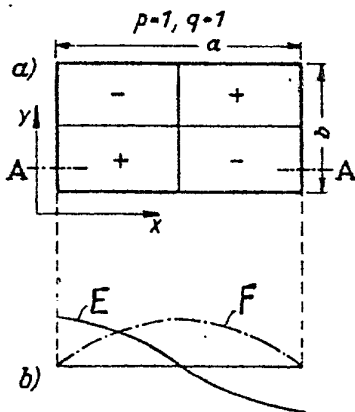

Fig.18

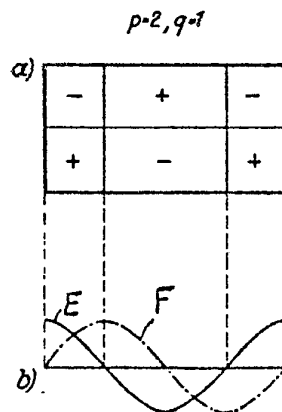

Fig.19

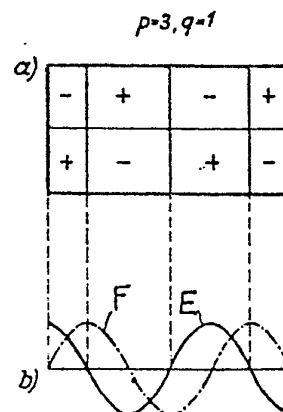

Fig.20

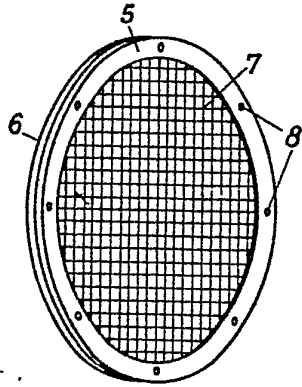

Fig. 21

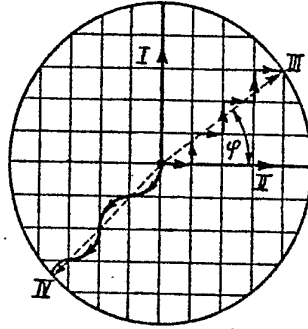

Fig. 22

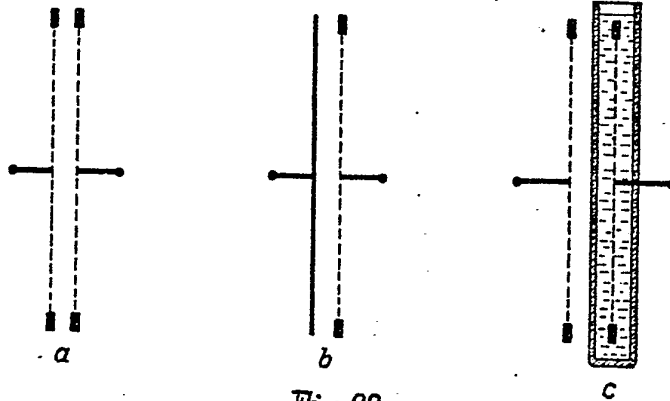

Fig. 23

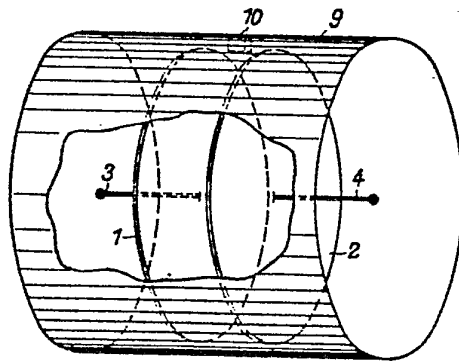

Fig. 24

[This Drawing is a reproduction of the Original on a reduced scale.]

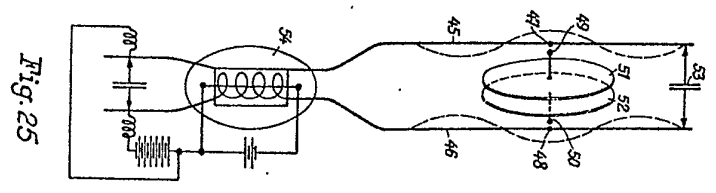

Fig. 25

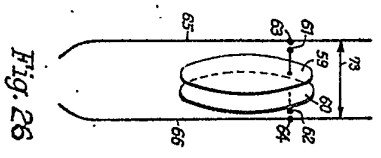

Fig. 26

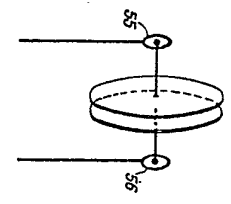

Fig. 27

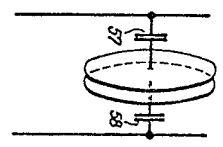

Fig. 28

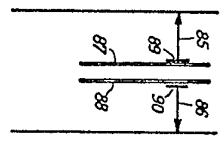

Fig. 29

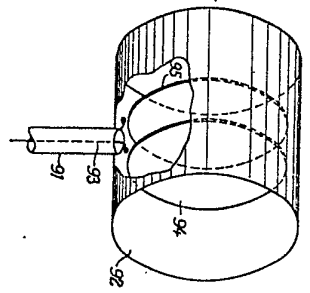

Fig. 30

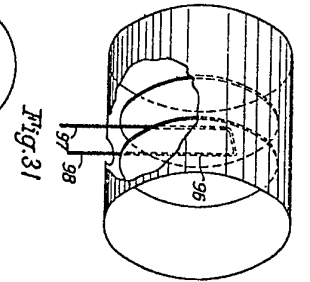

Fig. 31

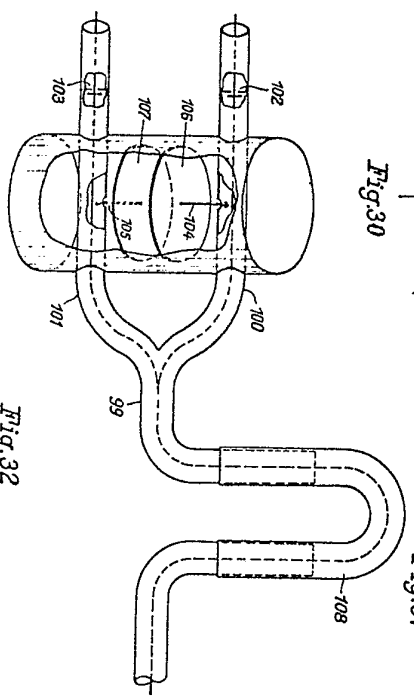

Fig. 32

[This Drawing is a reproduction of the Original on a reduced scale.]

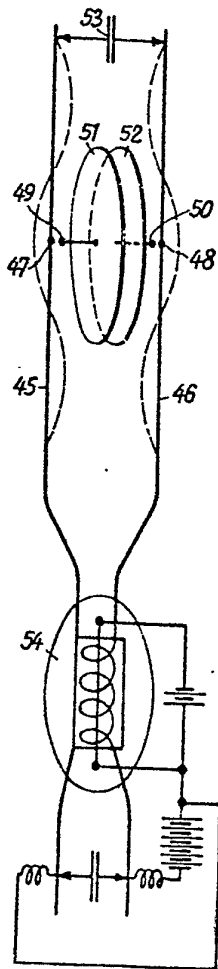

Fig. 25

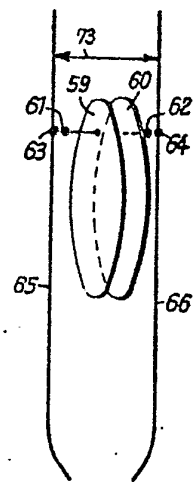

Fig. 26

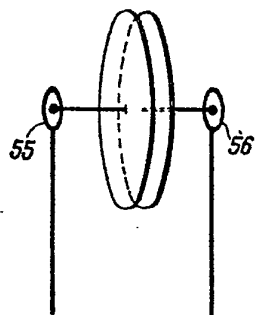

Fig. 27

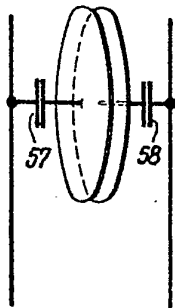

Fig. 28

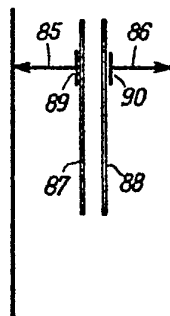

Fig. 29

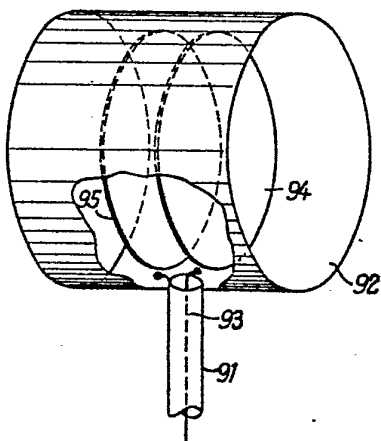

Fig. 30

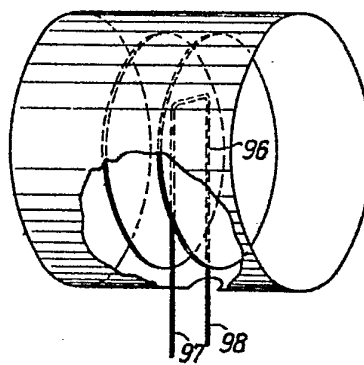

Fig. 31

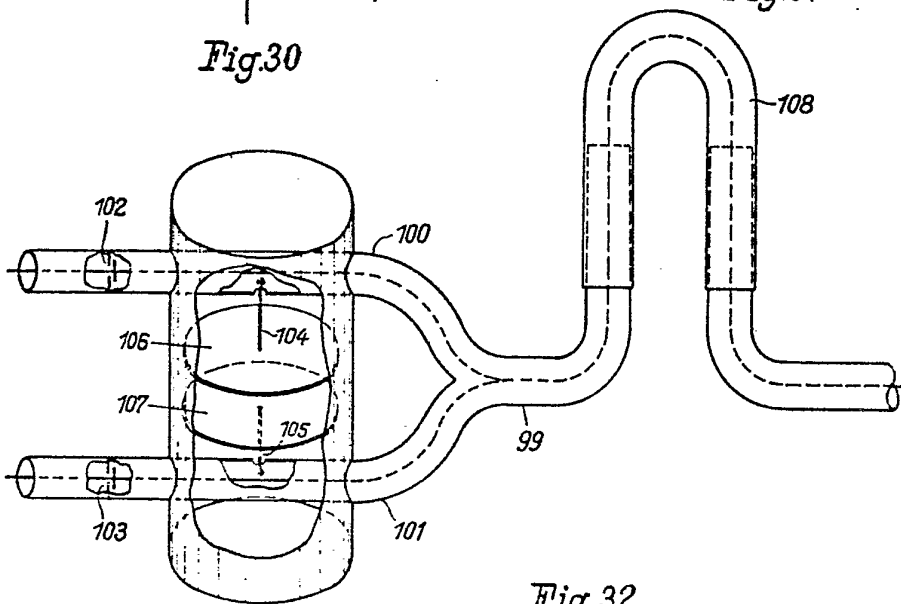

Fig. 32

[This Drawing is a reproduction of the Original on a reduced scale.]

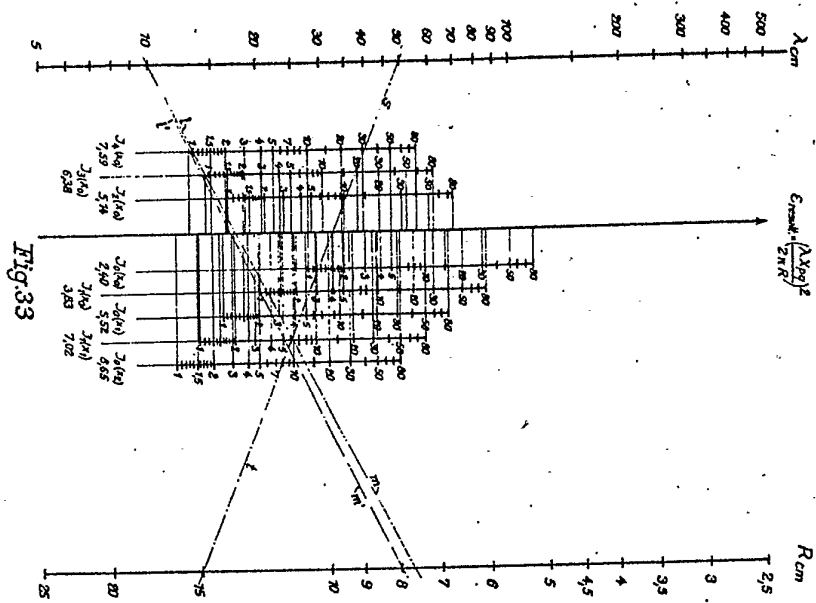

Fig. 33

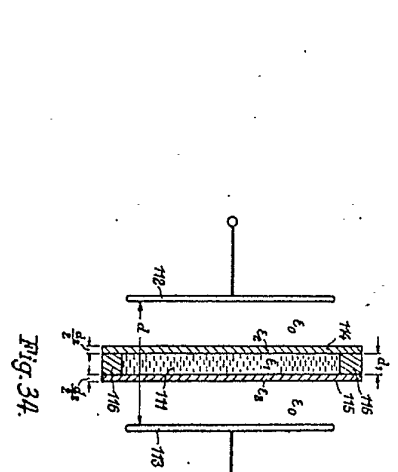

Fig. 34.

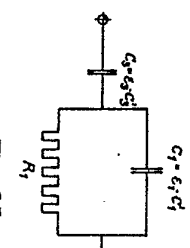

Fig. 35.

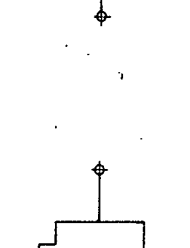

Fig. 36.

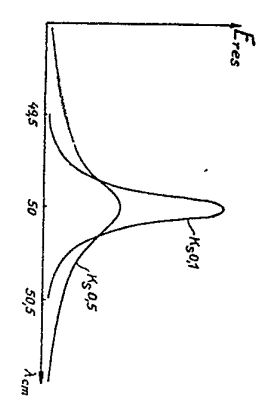

Fig. 37.

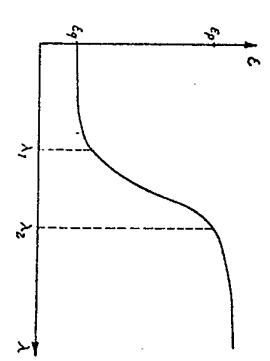
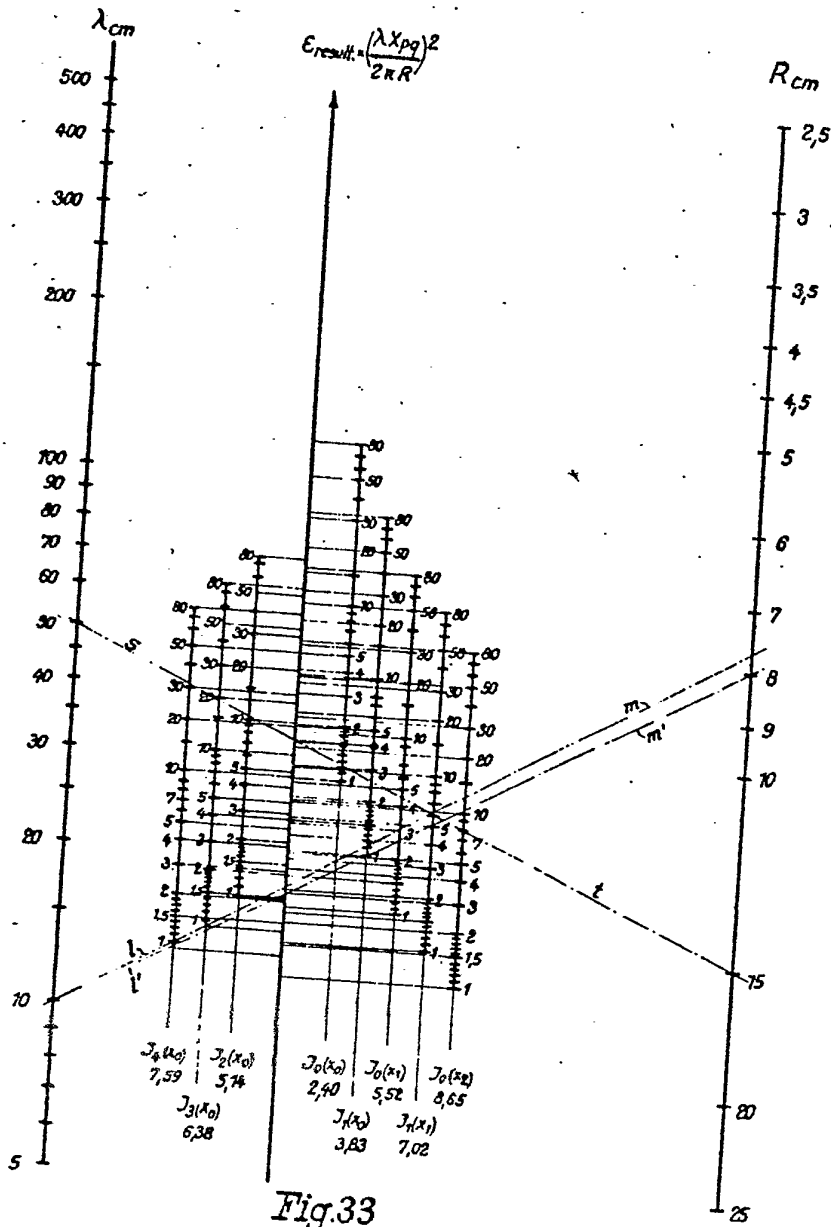

Fig. 38.

[This Drawing is a reproduction of the Original on a reduced scale.]



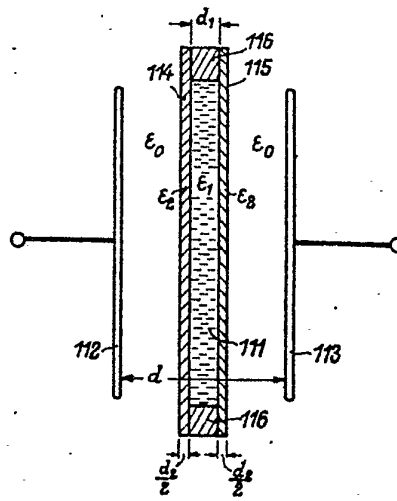

Fig. 34.

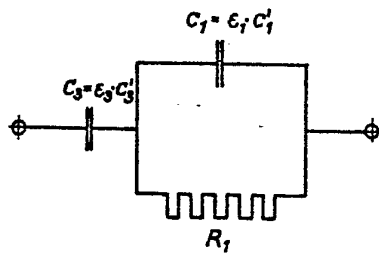

Fig. 35.

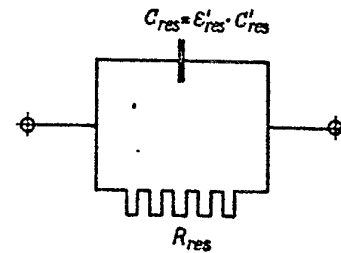

Fig. 36.

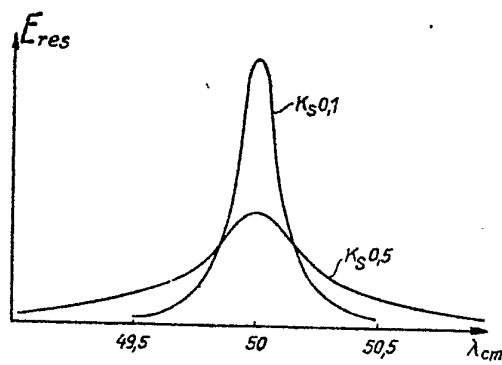

Fig. 37.

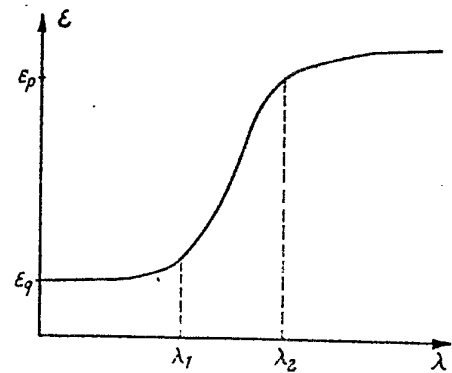

Fig. 38.

[This Drawing is a full-size reproduction of the Original.]

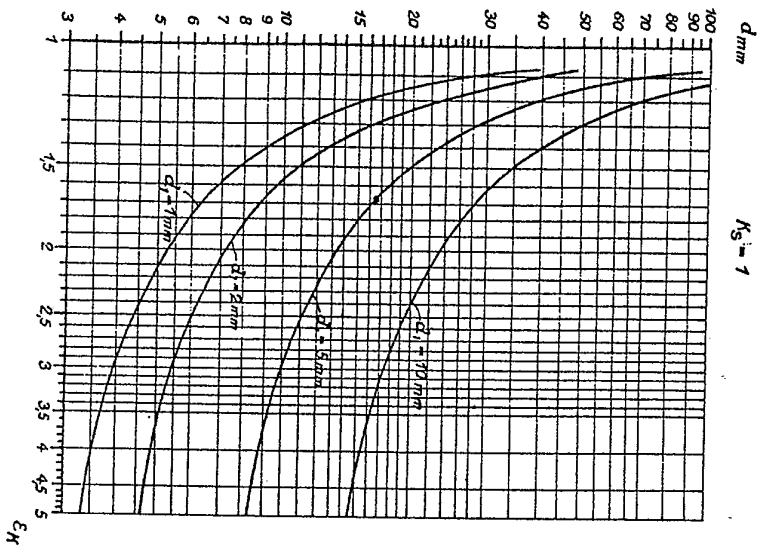

Fig. 39.

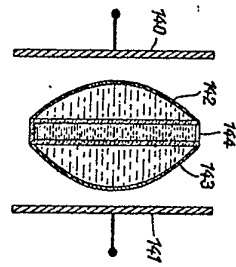

Fig. 41.

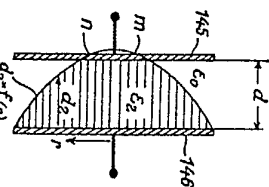

Fig. 42.

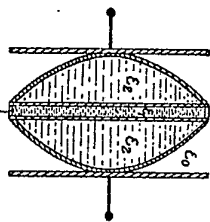

Fig. 43.

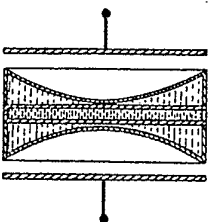

Fig. 44.

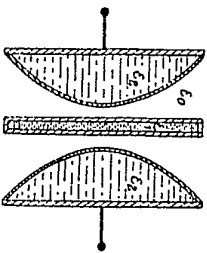

Fig. 45.

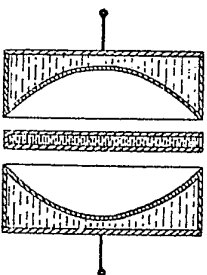

Fig. 46.

[This Drawing is a full-size reproduction of the Original.]

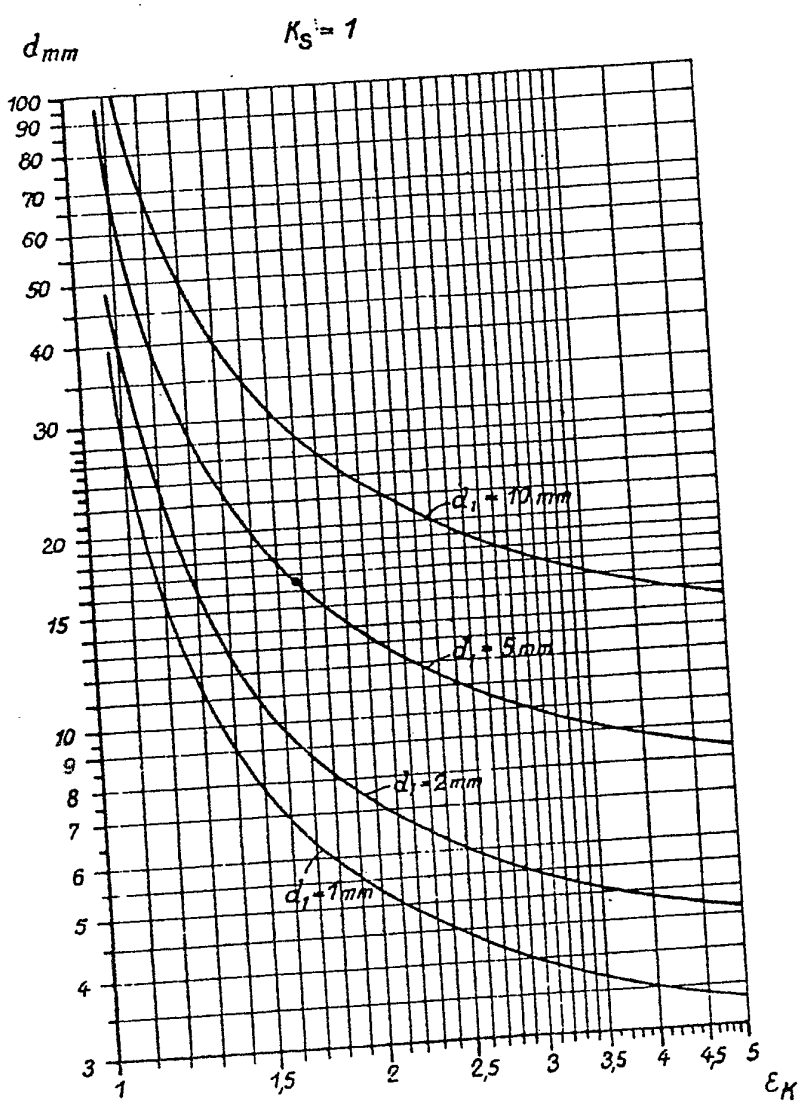

Fig. 39.

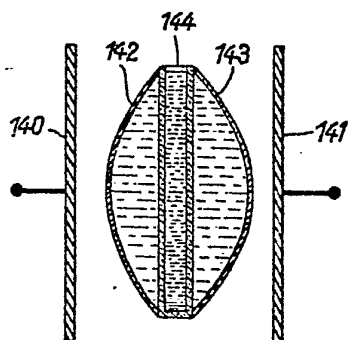

Fig. 41.

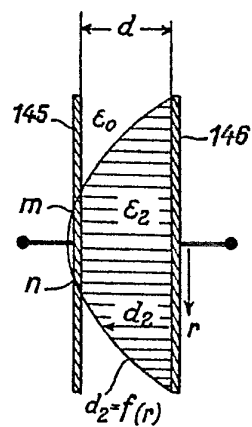

Fig. 42.

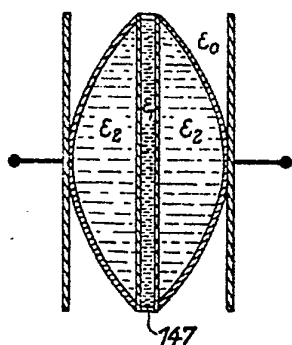

Fig. 43.

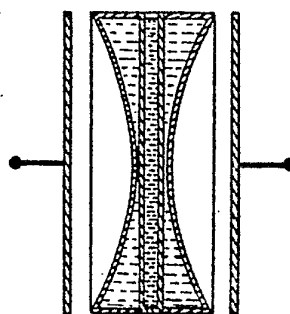

Fig. 44.

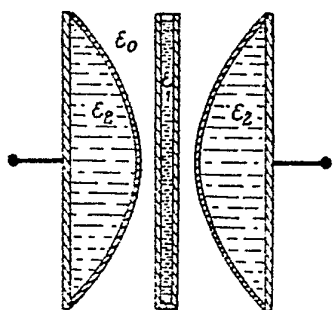

Fig. 45.

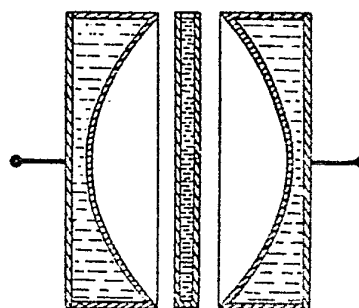

Fig. 46.

[This Drawing is a full-size reproduction of the Original.]

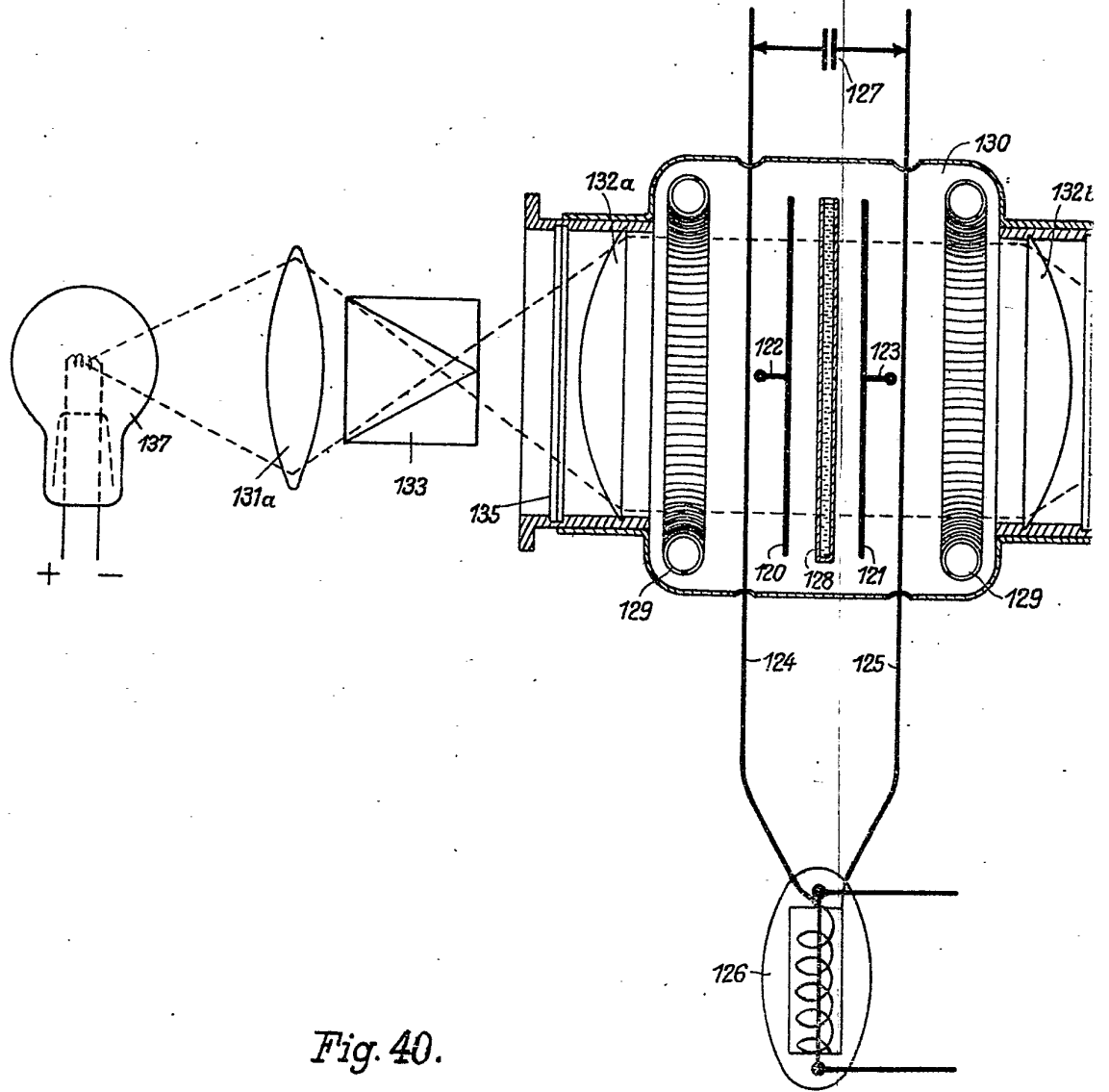

Fig. 40.

[This Drawing is a reproduction of the Original on a reduced scale.]

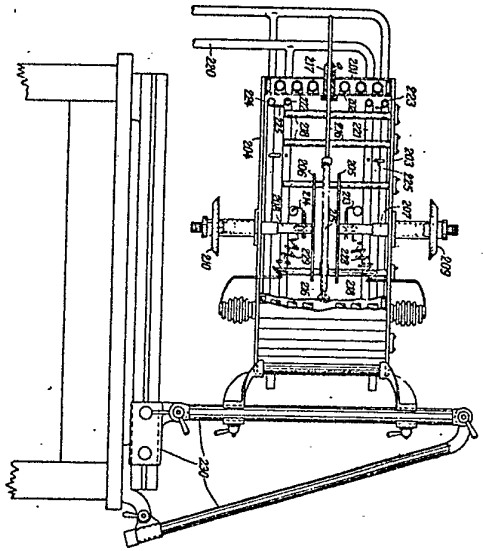

Fig. 47.

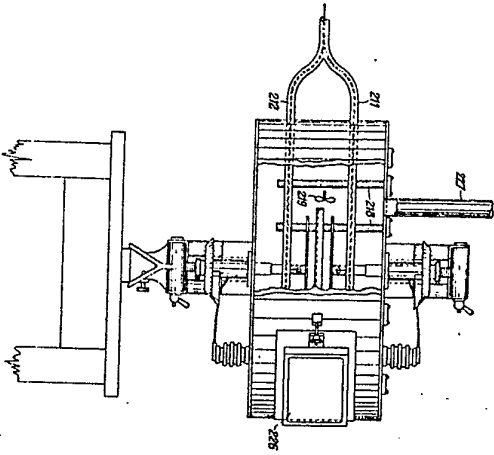

Fig. 48.

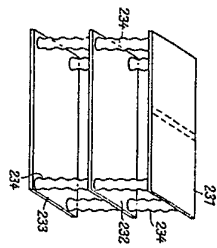

Fig. 49.

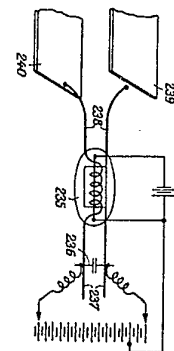

Fig. 50.

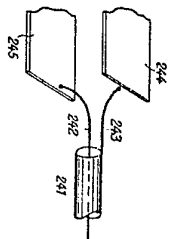

Fig. 51.

[This Drawing is a reproduction of the Original on a reduced scale.]

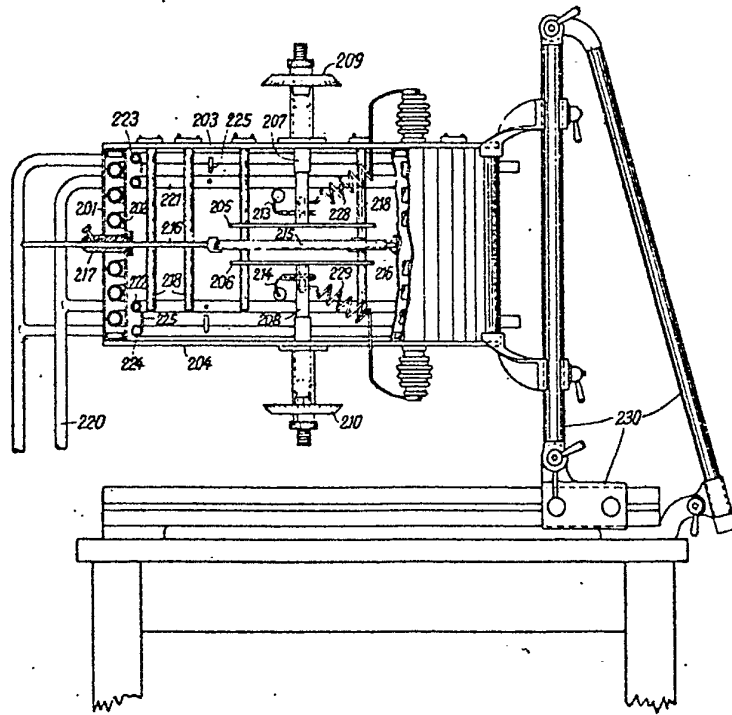

Fig. 47.

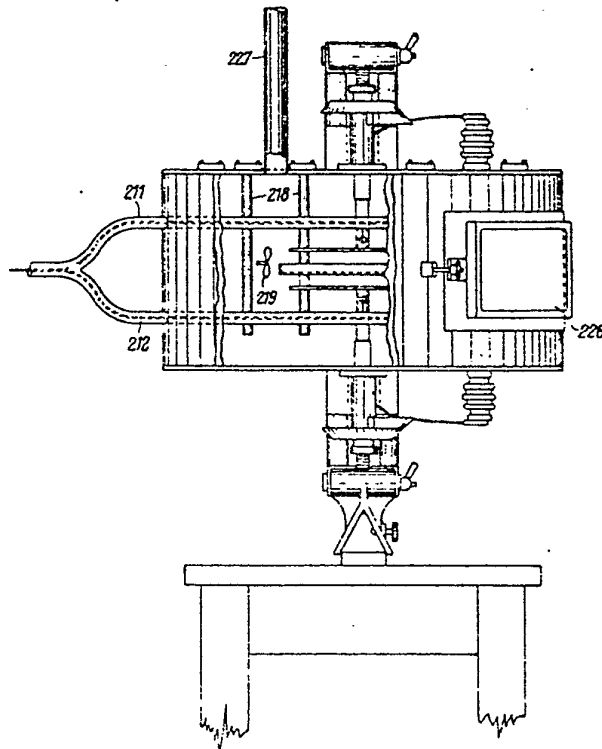

Fig. 48.

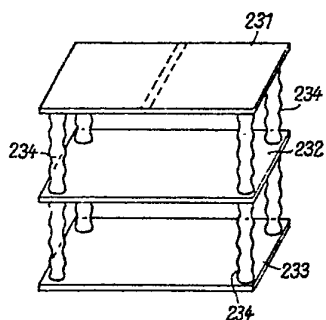

Fig. 49.

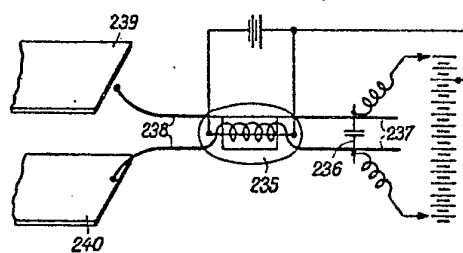

Fig. 50.

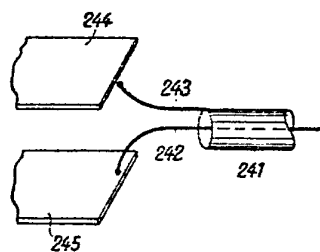

Fig. 51.