

1968

# Effects of various electrical fields on seed germination

Fredrick Warner Wheaton  
*Iowa State University*

Follow this and additional works at: <http://lib.dr.iastate.edu/rtd>



Part of the [Agriculture Commons](#), and the [Bioresource and Agricultural Engineering Commons](#)

---

## Recommended Citation

Wheaton, Fredrick Warner, "Effects of various electrical fields on seed germination " (1968). *Retrospective Theses and Dissertations*. 3521.  
<http://lib.dr.iastate.edu/rtd/3521>

This Dissertation is brought to you for free and open access by Iowa State University Digital Repository. It has been accepted for inclusion in Retrospective Theses and Dissertations by an authorized administrator of Iowa State University Digital Repository. For more information, please contact [digirep@iastate.edu](mailto:digirep@iastate.edu).

This dissertation has been  
microfilmed exactly as received

69-4288

WHEATON, Fredrick Warner, 1942-  
EFFECTS OF VARIOUS ELECTRICAL FIELDS ON  
SEED GERMINATION.

Iowa State University, Ph.D., 1968  
Engineering, agricultural

University Microfilms, Inc., Ann Arbor, Michigan

EFFECTS OF VARIOUS ELECTRICAL  
FIELDS ON SEED GERMINATION

by

Fredrick Warner Wheaton

A Dissertation Submitted to the  
Graduate Faculty in Partial Fulfillment of  
The Requirements for the Degree of  
DOCTOR OF PHILOSOPHY

Major Subject: Agricultural Engineering

Approved:

Signature was redacted for privacy. 7

In Charge of Major Work

Signature was redacted for privacy.

Head of Major Department

Signature was redacted for privacy.

Dean of Graduate College

Iowa State University  
Ames, Iowa

1968

## TABLE OF CONTENTS

	Page
INTRODUCTION	1
OBJECTIVES	3
REVIEW OF LITERATURE	4
Natural Earth-Atmosphere Electricity	4
Plant Response to Electrically Modified Environments	6
Plant Response to Electric Current	20
Seed Response to Electrical Energy	24
Correlation and Explanatory Studies of Bioelectric Potentials	37
Summary	52
APPARATUS	54
PROCEDURE	63
METHODS OF DATA ANALYSIS	67
DISCUSSION OF RESULTS	90
CONCLUSIONS	103
SUMMARY	105
SUGGESTIONS FOR FURTHER STUDY	107
BIBLIOGRAPHY	109
ACKNOWLEDGMENTS	118
APPENDIX A	119
Experimental and Calculated Data	119
APPENDIX B	183
Computer Programs	183

## LIST OF FIGURES

	Page	
Figure 1	A comparison of dry weight response for A.C. and D.C. electric fields for a monocotyledon and a dicotyledon	19
Figure 2	A comparison of dry weight response for monocotyledons and dicotyledons in a continuously applied electrostatic field	19
Figure 3	Tolerance of wheat, as indicated by germination, to radio frequency electrical treatment at the indicated moisture levels (wet basis), when exposure ranged from 4 to 37 seconds	31
Figure 4	Treating chamber with metering system for dry soybean seeds	55
Figure 5	Treating chamber showing the power train to the dry soybean seed metering system	55
Figure 6	Treating chamber showing the entire drive mechanism for the dry soybean seed metering attachment	58
Figure 7	Schematic wiring diagram for treating chamber	58
Figure 8	Belt type metering system	59
Figure 9	Detail of seed hopper and metering mechanism	59
Figure 10	Detail of seed release mechanism	61
Figure 11	Operation of the belt type metering machine, treating chamber and associated electrical equipment when treating soaked soybean seeds in an alternating electric field	61
Figure 12	Steam generator	62
Figure 13	Moisture absorption curves at 85 degrees Fahrenheit for corn and soybean seeds immersed in tap water	65
Figure 14	Germination rate of unsoaked soybeans after treatment in a static electric field	68
Figure 15	Germination rate of unsoaked soybeans after treatment in a 60 hertz electric field	69

## LIST OF FIGURES (continued)

	Page
Figure 16 Germination rate of unsoaked corn after treatment in a static electric field	70
Figure 17 Germination rate of unsoaked corn after treatment in a 60 hertz electric field	71
Figure 18 Germination rate of soaked soybeans after treatment in a static electric field	72
Figure 19 Germination rate of soaked soybeans after treatment in a 60 hertz electric field	73
Figure 20 Germination rate of soaked corn after treatment in a static electric field	74
Figure 21 Germination rate of soaked corn after treatment in a 60 hertz electric field	75
Figure 22 Transformed plot of the germination rate of unsoaked soybeans after treatment in a static electric field	77
Figure 23 Transformed plot of the germination rate of unsoaked soybeans after treatment in a 60 hertz electric field	78
Figure 24 Transformed plot of the germination rate of unsoaked corn after treatment in a static electric field	79
Figure 25 Transformed plot of the germination rate of unsoaked corn after treatment in a 60 hertz electric field	80
Figure 26 Transformed plot of the germination rate of soaked soybeans after treatment in a static electric field	81
Figure 27 Transformed plot of the germination rate of soaked soybeans after treatment in a 60 hertz electric field	82
Figure 28 Transformed plot of the germination rate of soaked corn after treatment in a static electric field	83
Figure 29 Transformed plot of the germination rate of soaked corn after treatment in a 60 hertz electric field	84

## LIST OF TABLES

		Page
Table 1	Effect of current flow through soil on plant growth	22
Table 2	Germination characteristics	36
Table 3	Summary of the types of treatments used	63
Table 4	Regression analysis for data from experiments with air dry soybeans	92
Table 5	Regression analysis for data from experiments with air dry corn	93
Table 6	Regression analysis for data from experiments with soaked soybeans	94
Table 7	Regression analysis for data from experiments with soaked corn	95
Table 8	Analysis of variance for data from experiments with air dry soybeans	98
Table 9	Analysis of variance for data from experiments with air dry corn	98
Table 10	Analysis of variance for data from experiments with soaked soybeans	99
Table 11	Analysis of variance for data from experiments with soaked corn	99
Table 12	Summary of the F test values	100
Table 13	Summary of the t test values for the regression coefficients of exposure time and voltage	101

## INTRODUCTION

The use of electrical energy to influence the response of biological systems was first attempted, according to Solly (96), in 1746 by Dr. Maimbray of Edinburgh. He electrified two myrtle plants for the entire month of October and observed that they put forth small branches a few inches in length and even began to blossom. Several myrtle plants close by but not electrified showed none of these responses.

Since Dr. Maimbray, many investigators have studied the use of electrical energy to influence plant growth. Many of these investigators (3, 58, 98, 100) have shown yield increases from plants which were subjected to an electrical treatment. Others (60, 62, 88) have found electrical energy caused a decrease in growth rate, while a third group of investigators (27, 34, 96, 104) have found that electrical energy does not affect plant growth. Unfortunately, the research done by these men was conducted using different treatment procedures and different environmental conditions which makes comparisons and the drawing of general conclusions difficult if not impossible. At present, insufficient data are available to determine if one group is correct while the others are not or if they are all correct under certain circumstances.

In light of the lack of agreement regarding the treatment of plants with electrical energy, this investigation was designed to determine if placing corn or soybean seeds in an electric field for a period of time would influence their germination rate. If it does, the time period between planting and emergence could be reduced. Early emergence usually means a more healthy and vigorous crop which produces higher yields.



This is especially true in areas where the growing season is limited in length. Early emergence would also provide the crop with a competitive advantage over weeds by allowing the crop to get established ahead of the weeds.

This study should give a better understanding of the response of seeds to electric fields. If corn or soybeans respond to this treatment either positively or negatively, it would not be unreasonable to also suspect that weed seeds might respond to such a treatment. Since the differences between weed seeds and corn and soybean seeds are as pronounced as their similarities, it would be probable that the optimum levels for the treatment variables would be different for weed seeds and for corn and soybean seeds. If so, this could provide a new method of weed control.

Thus, the application of electrical energy to biological organisms holds promise of increasing our food production. This could be brought about by using electrical energy to stimulate growth of desirable organisms or by using it to retard growth or reproduction of undesirable organisms. If either of these approaches produces a positive result, mankind will benefit.

## OBJECTIVES

This investigation was designed to determine if electric fields have an effect on the germination rate of corn and soybean seeds. The specific objectives are:

1. To determine if exposure of corn and soybean seeds to an electric field will affect the germination rate.
2. To determine if duration of exposure in an electric field has any effect on the germination rate of corn and soybeans.
3. To determine if electric field intensity has any effect on the germination rate of corn and soybeans.
4. To determine if treating presoaked corn and soybean seeds in an electric field will influence their germination rate.

## REVIEW OF LITERATURE

Many factors have shown an influence on plant growth. Temperature, humidity, moisture level, and solar radiation are only a few of the more familiar ones. One factor which is not usually considered is the natural electrical environment in which all organisms must live.

## Natural Earth-Atmosphere Electricity

Many investigators have shown that plant life is surrounded by a continuous flux of electrical currents. Briggs et al. (5) stated that on a clear day in an open field there was a potential gradient in the atmosphere of approximately 100 volts per meter. Variations in the magnitude of this potential are almost continuous, but during good weather the earth normally remains negative with respect to the atmosphere. During a thunderstorm the potential may reach 10,000 volts per meter and may have the opposite polarity. McDonald (56) estimated that the ionosphere was 400,000 volts positive with respect to the earth.

Briggs et al. (5) believed the air to earth current was approximately  $2 \times 10^{-12}$  amperes per square meter ( $5 \times 10^{-8}$  amperes per acre). The exact value depends on the potential gradient, number of ions per unit volume of air, and the mobility of the ions. This current was due to lightning, ion movement, motion of charged rain droplets, dust particles, and other particles in the air.

Simpson (93), working in India, developed an instrument for measuring the charge on raindrops. His observations took place between April and September of one year during which 76.3 centimeters of rain

fell. He summarized his data as follows: (1) 71 percent of the time that charged rain fell it was positively charged, (2) 75 percent of the electricity brought down by rain was positive, (3) light rain was more highly charged than heavy rain, (4) most light steady rains carried a negative charge while heavy rains nearly always carried a positive charge, (5) during the majority of rainstorms the atmosphere was negative with respect to the earth, (6) no relationship was found between the direction of the potential gradient and the charge on the raindrops.

Briggs et al.(5) estimated that the earth-air current was great enough to reduce the charge on the earth to one-half its original value in 10 minutes. McDonald (56) summarized a theory proposed by C. T. R. Wilson to explain why the earth does not lose its charge. He theorized that the direction of current flow during fair weather was from the atmosphere to earth. During storms the direction of flow reversed. Wilson calculated that there are approximately 3,600 thunderstorms going on in the world at any one moment. From this and estimates of current flow during fair and foul weather, he was able to show that a balance of current flow exists between the earth and the atmosphere. This enables the earth to maintain its charge.

Scott (89) showed that plants contain ions and possess electrical potentials. Lund et al. (49) mapped the electrical potentials which existed in an onion root. These facts demonstrated that plants contain substances which are affected by electrical activity occurring nearby. Thus, normal atmospheric potentials may exert considerable influence on plant growth. For example, Lemstrom (43) called attention to the rapid and

succulent growth of plants in the far northern latitude. He attributed at least part of this to the high electrical state of the northern atmosphere. To support his point he conducted studies on sections of fir trees from different latitudes. He found periods of yearly growth which corresponded fully with periods of high sun spot and aurora activity. Comparisons of growth variations in large trees from polar regions of 67 degrees north latitude with trees from a more southerly latitude of about 60 degrees, showed these periodic variations to be greater in the more northerly latitudes.

#### Plant Response to Electrically Modified Environments

Solly (96) credited Professor Gardini as being the first to attempt to use modified atmospheric electricity to control plant growth. About 1770 Professor Gardini stretched a number of iron wires above the garden of a monastery at Turin. After a short time the garden, which previously had been very productive, began to fail. The plants became unproductive and withered away. The monks attributed the failure to Gardini's wires and took the wires down. Within a short time the garden returned to its former productiveness. Gardini explained that the wires deprived the plants of their natural supply of electricity which was necessary for their growth.

Abbe Bertholon, according to Solly (96), attempted in 1783 to increase the supply of atmospheric electricity to plants. He attached a pointed conductor to the top of a high pole and connected this to a wire suspended over some growing plants. He attributed the increased growth

and improved appearance of the plants below the wire to the increased electrical energy available.

Solly (96) attached a star made of 30-in-long copper rods to a 33-foot-high pole. One of these poles was located at each end of a small field. These stars were connected to a network of wires laid 4 inches below the soil surface and 12 inches apart. Barley was planted over the wires and observed until maturity. No differences were observed between the treated and control plots.

In other experiments Solly (96) suspended 12-foot-long wires vertically and at 4-foot intervals above 50-foot-long rows of potatoes. The rows were 3 feet apart. During growth and at harvest no differences could be found between the treated and untreated potatoes. On another plot in the same experiment a wire was buried 6 inches deep on each side of the potato rows. A third wire was connected to these wires and suspended horizontally above the row. One-foot lengths of wire were vertically suspended from this wire at 12-inch intervals. These potatoes showed no effect from the treatment.

In Utah (100) wires were buried 3 feet apart and 10 inches deep in plots 2 rods square. After connecting the wires to a copper brush mounted atop a pole 20 feet high, seeds of various crops were planted in rows running at right angles to the direction of the buried wires and extending across an untreated plot also 2 rods square. One year's data showing the grain yields from the treated plots compared with those of the untreated plots were as follows: oats, 67 percent increase; beans, 41 percent increase; buckwheat, 21 percent increase; potatoes, 10 percent

increase; mangels, 32 to 115 percent increase; turnips, 59 percent decrease to 36 percent increase.

Dorchester (27) buried No. 22 copper radio cable 12 inches beneath plots of corn, soybeans, garden beets, string beans, swiss chard, and turnips. The buried wires were connected in various experiments to eight different types of brushes mounted on poles 20 feet high. These brushes consisted of from 18 to 27 small diameter rods put together in different arrangements, lengths, and number to form the eight types of brushes. The rods varied in length from 6 to 18 inches while the brushes varied in diameter from 8 to 14 inches. Experiments were conducted over a three-year period and in this case under a variety of weather conditions. Observations were made on the rate of emergence of the crop plants above the ground, vigor and rapidity of growth, and time of maturity for each crop. The average current flowing in the wire between one brush and ground was about  $3.0 \times 10^{-9}$  amperes although wide variations occurred both in magnitude and direction of flow. The type of brush used had no effect on this current. The results showed the largest yield increases were obtained with chard and beets, the increase being approximately 7 percent and 9 percent respectively. However, the variations within treatments were quite large and forced Dorchester to conclude that larger differences must be observed before a significant conclusion could be stated.

Stone (98) placed a copper plate in each end of a greenhouse flat (dimensions of 53 x 32 x 7 inches). He connected one plate to ground and the other to a copper brush positioned 47 feet above the ground surface.

This connection produced a slight continuous current. In tests with 738 radish plants he achieved average increases for the treated plants of 12.67 percent in root weight, 45.28 percent in weight of the tops, and 28.47 percent in the weight of the entire plant. With 47 lettuce plants the same treatment resulted in a weight increase of 39.22 percent over the control plants.

Zhurbitskii and Shidlovskaya (107), while studying the effect of insulating plants from the atmospheric electrical field, found that onions showed a 30 to 50 percent decrease in nitrogen, calcium, and phosphorous absorption and a slight increase in potassium content. Decreases occurred in both absolute and relative amounts of all nutrients when barley plants were shielded from the atmospheric potential. Under similar treatment corn plants showed a high relative mineral content. Their findings indicated that insulation from the natural electric field affected the process of organic synthesis more than the absorption activity of plants.

Cherry (19), quoting Grandeau, stated that protecting plants from atmospheric electricity caused plant growth to be retarded.

Monahan (58) found that trees modified the electrical field under them. He measured the atmospheric potential under a Norway pine and an elm tree, and compared these data with the potential observed in an open area nearby. He found the Norway pine reduced the atmospheric potential beneath itself all year. An elm tree modified the potential significantly only when the leaves were out.

Monahan (58) tested the effect of electrically charged air on plant



growth. He placed radish plants in a glass box and charged the air in the box once per day to approximately 150 volts. The box was kept closed for four hours after charging the air and then opened for the remaining 20 hours of the day. The charge remained for less than 15 minutes after charging. His results showed the treated plants had an average weight increase of 51.62 percent over the controls. The radish tops had an average weight increase of 49.35 percent and the roots an average weight increase of 57.56 percent over the controls.

Several investigators have attempted to use highly charged overhead wires to stimulate plant growth. By supporting these wires on insulators attached to posts, the electrical discharge was forced to travel through the air to get to earth. Since the plants were growing in a higher than normal potential gradient, the responses of plants caused by electric fields should be more evident.

Cherry (19) described Professor Lemstrom's experiments to utilize charged wires above the crop. Lemstrom stretched charged horizontal wires 16 inches above the crop and 4 feet apart. He treated strawberries, corn, potatoes, and beets. His results showed yield increases of from 50 to 128 percent for strawberries, 35 to 40 percent for corn, 20 percent for potatoes, and 26 percent for beets. Lemstrom concluded that an overall average increase in yield of 45 percent over normal crops on land of ordinary fertility could be expected.

One problem with Professor Lemstrom's system was the necessity of moving the wires upward as the crop grew. This was time-consuming and the wires made movement through the field with any animals or equipment

impossible. Sir Oliver Dodge, according to Cherry (19), eliminated these problems by suspending the charged wires on insulators attached to high poles. He suspended wires several yards apart in a grid pattern over plots of wheat. He claimed a 40 percent increased yield from Canadian Red Fife wheat and a 30 percent increase from an English variety of wheat with this system. He mentioned that bakers claimed wheat from treated plots had better quality than normal wheat.

Newman (75) in cooperation with R. Bomford and Sir Oliver Lodge conducted a series of experiments between 1906 and 1922. They erected a wire network 15 feet above the ground consisting of thin galvanized steel or bronze wires. These wires were set 10 feet apart and were supported on telegraph wires. The telegraph wires were suspended on insulators attached to posts set 71 yards apart and in parallel rows 102 yards apart. The wire network was charged with 50,000 to 75,000 volts by connecting it through Lodge valves to the positive pole of an induction coil. The negative pole was grounded. During seven years of tests on wheat (1905-1911) in Evesham, England, Newman (75) reported average yield increases of 21 percent in grain weight for all years except 1911 when no increase was shown. The 1911 failure was attributed to drought since both control and treated plots yielded only 16 bushels per acre. Potatoes grown on installations in Dumfries, Scotland, showed yield increases of 20 to 25 percent during two seasons when only one electrified and one control plot were grown. The third year, when the treated and control plots were arranged in a chessboard pattern, there was no difference in yield. However, later work indicated that the control

plots under this arrangement were unintentionally electrified, which would explain the results. He indicated strawberries grown outside showed no advantage or a slight disadvantage for this system. This was opposed to results obtained in experiments on strawberries grown in a greenhouse. Newman (75) mentioned that all the strawberries grown outdoors had a higher yield than nearby fields, and the berries from the electrified plots had a sweeter flavor. Since the chessboard pattern of planting was used here also, the entire field may have been electrified. Tests were also conducted on sugar beets in several European locations. Increased sugar content of the beets accompanied a 20 percent or greater increased beet yield.

Priestley (81) experimented with an overhead discharge apparatus similar to Newman's (75). He used number 24 wire set at 30-foot intervals and suspended 16 feet above the ground to make his overhead grid. He charged the grid to from 60,000 to 100,000 volts and measured the drift of the charge (ions) as a function of the wind. He found that control plots several hundred yards downwind from an electrified plot were subjected to the same electrical environment as the treated plot. He found that the normal atmospheric current is approximately  $1 \times 10^{-16}$  amperes per square centimeter. In an electrified plot treated as described above, he measured a current flow downward of  $1 \times 10^{-12}$  to  $1 \times 10^{-11}$  amperes per square centimeter.

Hendrick (34) used a rectified alternating voltage for charging an overhead wire discharge grid to a potential of from 60,000 to 100,000 volts. Fine cotton-covered wire alternating with fine bare wire was used

to construct the network with 15-foot-square grids. This entire network was suspended 11 to 15 feet above the ground on number 8 galvanized wires set 70 to 88 yards apart. After five years of tests in Kincardineshire, Scotland, he concluded that this treatment caused no yield increase with oats, barley, hay, potatoes, turnips, or swedes.

Blackman and Legg (3) conducted tests utilizing the overhead discharge principle on maize, barley, and wheat. These tests, carried out both in the greenhouse and the open, were done over a period of four years. Wheat, barley, and maize showed an increase in dry matter production when subjected to minute electric discharge currents (as low as  $1 \times 10^{-11}$  amperes per plant). Maize plants a little over a month old showed a dry matter increase of  $27 \pm 5.8$  percent. With barley the largest increase observed was  $18 \pm 2.4$  percent. They found that direct and alternating currents were equally effective in stimulating plant growth. This stimulating effect was produced by charging the wire network either positive or negative. Current flows of  $1 \times 10^{-11}$  amperes per plant were as effective as higher densities, but currents greater than  $1 \times 10^{-8}$  amperes per plant were injurious to the plants. They concluded that there is minimum, optimum, and maximum current level for stimulating plant growth. These levels change with the type of discharge used, period of application, kind of plant, stage of growth of the plant, and external conditions.

Blackman (2) stretched thin insulated wires 7 feet above the ground and spaced 5, 10, or 15 feet apart. These were charged with from 40,000 to 80,000 volts and had a discharge current of from  $5 \times 10^{-4}$  to  $1 \times 10^{-3}$

amperes per acre. He usually applied this discharge for six hours per day in two periods, three hours in the early morning and three hours in the late afternoon. Of the nine experiments with spring sown oats, he reported seven positive responses and two decreases in yield. The increases ranged from 2 to 57 percent above the controls while the decreases were 6 and 9 percent below the controls. The three experiments described with barley all showed increases in yield ranging from 10 to 36 percent over the control plots. Two years data on winter sown wheat showed one increase of 38 percent and one decrease of 4 percent for the treated plots over the control plots. The four experiments on clover hay conducted over two years showed three yield increases of 2, 34, and 50 percent and one decrease in yield of 6 percent. From these data Blackman (2) concluded that the overhead discharge treatment had a stimulating effect on plant production.

Blackman et al. (4) suspended a pointed rod approximately two centimeters above a barley coleoptile growing in a nutrient solution. This apparatus was placed in a dark room and the pointed rod charged to about 10,000 volts (crest value) through a lodge valve connected to a 50-cycle-per-second supply. The polarity varied with the experiment. Under these conditions the current passing through the coleoptile was about  $5 \times 10^{-11}$  amperes. The growth rate of the coleoptile for one hour immediately preceding application of current was taken as the standard rate. When the pointed rod was charged positive, the growth rate was  $4.65 \pm 1.19$  percent greater than the standard rate during the first hour. —If current was applied longer, the growth rate continued to increase

until in the third hour it was  $7.53 \pm 1.95$  percent above the standard rate. After cessation of current an "after effect" was apparent and consisted of a more rapid growth rate than when the current was on. For instance, growth rates during the fifth hour (two hours after the current stopped) were  $15.68 \pm 2.62$  percent above the standard rate. This "after effect" was greater with a one-hour discharge period than with a two- or three-hour discharge period. Blackman et al. (4) found that with the rod charged negatively the growth rate during discharge was only slightly greater than the control. The "after effect" was present but was somewhat reduced in magnitude.

In contrast to most of the English investigators, many of the scientists in other countries found no benefit due to overhead discharges.

Briggs et al. (5) working in Rosslyn, Virginia, constructed an overhead wire grid network similar to those used in England. He charged the network about 50,000 volts positive with respect to the ground which gave a potential gradient of approximately 10,000 volts per meter. This system produced no noticeable yield increase from tomatoes, cowpeas, cowpea vines, potatoes, turnips, beets, carrots, cabbage, buckwheat, or beans. After eight years of tests using both alternating and direct current, he concluded that electrifying soybeans, rye, winter wheat, or corn produced no yield increases or decreases.

Collins et al. (24) used an overhead network to treat seedling grain plants at Washington, D.C. The network was charged by direct current sufficient to give a discharge of  $1 \times 10^{-9}$  amperes per plant. One hundred seedlings were planted in each of 48 flats of corn and 24 flats

of barley. One-half of the flats were used as controls while the rest were subjected to an electrical discharge. Treatment was applied in three ways, (1) only during the day, (2) only during the night, (3) continuously. The only significant increase observed was with night treatment of corn. The second year these tests were run Collins concluded rapid water loss from the flats caused greater variation than the treatment. The third year growth was determined from total green weight of the plants, and results showed no difference between treated and controls.

Pickett and Schrank (79) studied the effect of an electric and a magnetic field on Avena coleoptiles when they were mounted on a klinostat. They mounted one metal plate above the coleoptile and one around its base. These plates were separated by 1.75 centimeters and charged with a direct current power supply. Plate voltages ranging from 500 to 2500 volts, applied longitudinally to the coleoptile, caused a significant increase in elongation and was independent of apical plate polarity.

Monahan (59) in summing up his studies on the effect of atmospheric electricity on plant growth made several points. These points were as follows: (1) atmospheric electricity does have a significant influence on plant growth; (2) there is a maximum potential above which plant damage will occur, there is a minimum potential below which no plant response will occur, and there is an optimum potential level which will give the highest positive response from the plant; (3) these levels will vary with the species and variety of plant; (4) within a variety and species these levels depend largely on size, structural differences, and

degree of development of the plant.

Murr (60-69) studied the growth of various plants when they were grown in an electrostatic or 60-cycle-per-second electrokinetic field. He found that grain sorghum (61, 68), orchard grass (63, 64, 65, 67), yellow bush bean (66), yellow wax beans (68), and corn (68) showed leaf tip damage when a "critical" potential was reached. Figure 1, taken from Reference 60, shows the effect of electrostatic and 60-cycle-per-second electrokinetic fields on the growth of sweet corn (monocotyledon) and bush beans (dicotyledon). It is interesting to observe that the character of electrotopism (response of plants to an electric field) was reversed for the electrostatic and electrokinetic fields for both plant types. Figure 2, also taken from Reference 60, shows the growth response in an electrostatic field as a function of field strength.

On the basis of his work, Murr (60) drew several conclusions. First, electrotopism occurred as an increase or decrease in harvested plant or leaf weight as a function of physiological differences. Secondly, electrotopism depended on whether the field used was electrostatic or electrokinetic. Thirdly, regardless of other responses, leaf damage occurred at some critical level and this damage was more severe for grass type blade leaves than for flat horizontally positioned leaves.

Murr (68,p.116) concluded that ". . .continuous exposure of plants to electric fields of nominal magnitudes much greater than the terrestrial field is not beneficial." However, he conceded that exposure of plants to lower intensity continuous electric fields or to short-time pulses of high field strengths might be beneficial since this might stimulate enzyme



Figure 1. A comparison of dry weight response for A.C. and D.C. electric fields for a monocotyledon and a dicotyledon

Figure 2. A comparison of dry weight response for monocotyledons and dicotyledons in a continuously applied electrostatic field

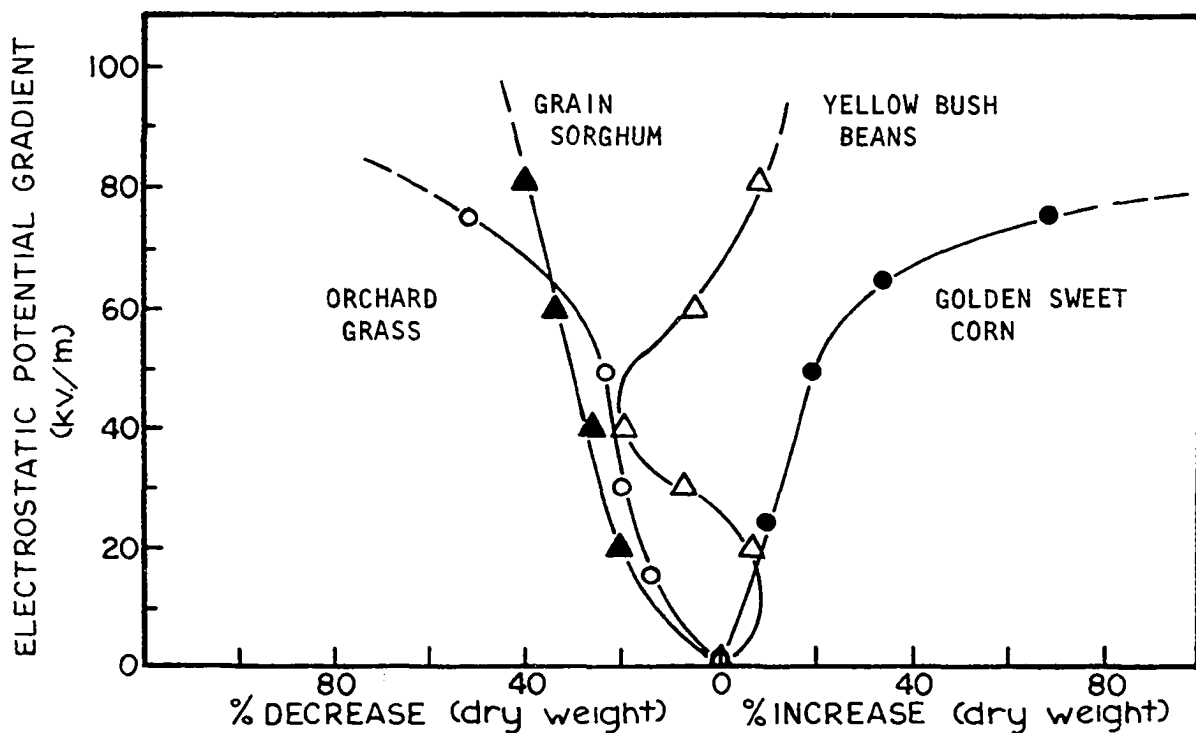
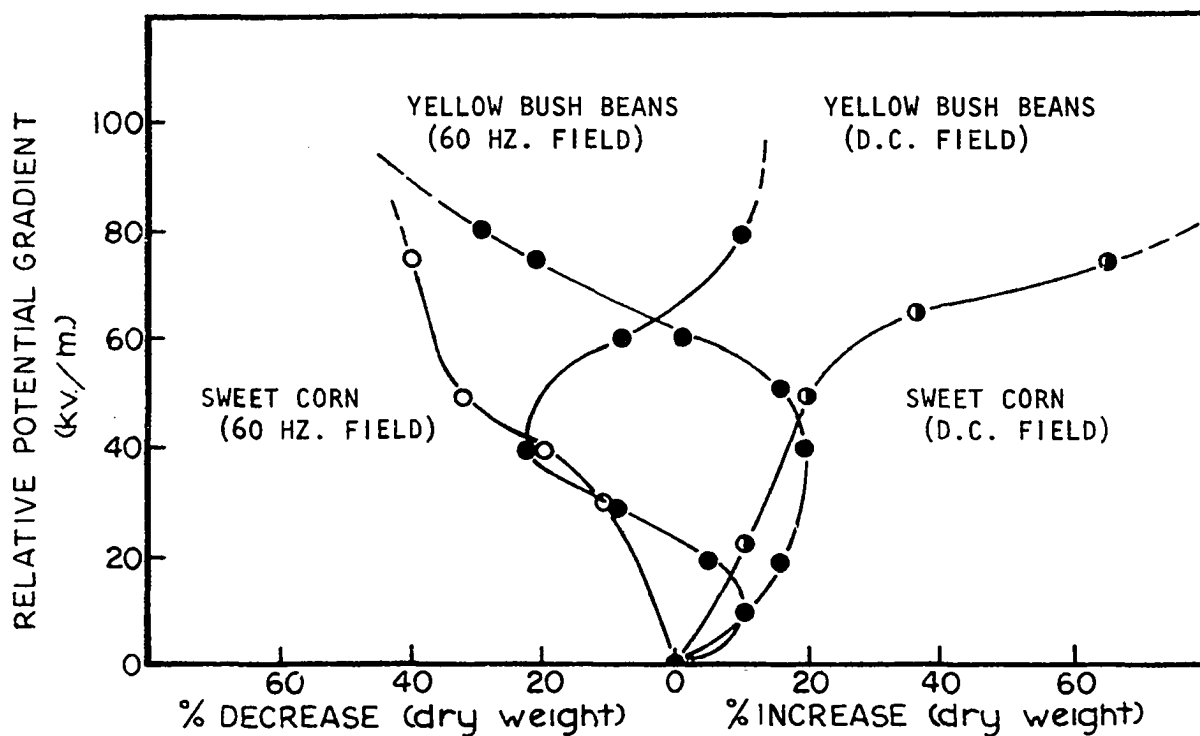

activity without damage to the plants.

#### Plant Response to Electric Current

Ross (87), attempting to test claims made by Marquis of Anglesea, appears to have been one of the first to attempt to influence the growth rate of a biological system by passing current through it. He mixed some black manganese oxide and table salt (sodium chloride) with clean sand. Cucumbers were planted in this mixture and dilute sulphuric acid (1 ounce sulphuric acid in 1 gallon of water) was sprinkled over it. Electricity was applied to the mixture. The cucumbers in the treated group emerged quicker than those in untreated lots.

In other experiments Ross (87) buried a copper plate 5 feet long and 14 inches wide across the end of three rows of potatoes. At the opposite end of these 100-foot-long rows an equal sized plate of zinc was similarly located. A copper wire was laid along the ground surface and connected to both plates creating a weak battery. The treated plots were said to have potatoes 2-1/2 inches in diameter on July second while the potatoes in the control plot were still the size of marrowfat peas.

Solly (96) in 1845 planted 140 small plots of grains, legumes, and various vegetables and flowers. One-half of these plots were reserved as controls and treated normally. In the 70 treated plots copper and zinc plates 4 inches by 5 inches were placed 6 inches apart. A copper wire connected one copper plate with one zinc plate, creating a weak battery. Seeds were sown in the soil between the plates and allowed to germinate, grow, flower, and form seed. The number of seeds which

emerged was noted. In six plots the number of seeds emerging was the same in the treated and control plots. In 32 tests more seeds emerged in the treated plots, but the remaining 32 plots showed more seeds emerged in the control plots. Observations during the remaining portion of the life cycle showed no difference between plants in the control and treated plots. Solly (96) concluded from these experiments that this type of electrical treatment had no effect on plant growth.

Stone (97) grew radishes and lettuce in greenhouse boxes 53 by 23 by 7 inches. One electrode plate was placed in each end of the box with seed sown between. For the various tests different combinations of electrode and current levels were used. Table 1 shows a summary of his results. These data led Stone (97) to conclude that alternating current was superior to direct current when applied to radishes in this manner. With direct current he found more top growth while with alternating current he increased root growth more.

In other work Stone (97) grew plants in water and passed current through the water. He found that with strong currents roots bent toward the anode, but weak currents caused bending toward the cathode. From all of his experiments he concluded that electricity affects the protoplasm in some unknown manner thereby causing the observed effects on growth.

Cholodny and Sankewitsch (20) passed weak current through oat (Avena sativa) coleoptiles of the variety Siegeshafer Svalof. If a current (positive charge flow) of from  $1 \times 10^{-6}$  to  $1 \times 10^{-7}$  amperes was passed from the base to the apex of oat or rye coleoptiles, growth was noticeably accelerated during the first 20 to 40 minutes. This period was most

Table 1. Effect of current flow through soil on plant growth<sup>a</sup>

Current (milliamps)	Electrodes	Number of plants	% gain in weight over controls		
			Roots	Tops	Whole plant
<u>Radish</u>					
Weak D.C.	Both copper	1,334	9.7	39.66	23.67
Stronger D.C.	Both copper	534	14.32	76.51	34.26
Interrupted induced	Both copper	334	18.87	8.76	12.40
D.C.	Copper and zinc connected	1,146	44.49	76.33	58.56
<u>Lettuce</u>					
0.184 D.C.	Both copper	94	--	--	22.78
0.367 D.C.	Both copper	46	--	--	40.76
0.214 D.C.	Copper and zinc connected	48	--	--	36.48

<sup>a</sup>Taken from Stone (97).

often followed by a definite retardation of growth. Doubling the current level during the experiment caused the cycle to be repeated. At temperatures of 14 to 16 degrees centigrade similar current flows were found to increase growth rate. Reversing the direction of current flow at the same intensities was found to retard coleoptile growth.

Molitorisz (57) connected 58 volts across a branch of two young citrus trees causing a current of approximately 1.6 milliamperes to flow through the branches. The direct current potential was applied for 28 days with the negative pole connected to the branch tip. The treated branches exhibited accelerated growth and greater leaf density than untreated branches. However, some leaf abnormality was present. The ripe fruit was dropped from the treated branches, but unripe fruit remained on the branch.

In other experiments Molitorisz (57) vertically positioned 1-foot-long pieces of citrus branch on sponges saturated with distilled water containing a neutral dye. Electrodes were connected to both ends with the negative electrode at the top. Twelve different branches were used with only the diameter as a major variable. Six of these branches were subjected to 58 volts supplied by a half wave rectifier while the remaining six served as controls. After 18 hours the dye had risen 1/4 inch in the control branches. In the treated samples dye had moved the full length of the branch and had clearly defined the channels of flow.

### Seed Response to Electrical Energy

Considerable research has been done to explore the possibility of using electrical energy to influence germination, water absorption, oil content, and other characteristics of seeds. Various methods of treatment and various portions of the electromagnetic spectrum have been used to treat the seeds.

Brown et al. (6) placed an electrode in each end of a sealed tube containing some seeds. The gas pressure was reduced inside the tube and the 60-cycle-per-second voltage across the electrodes was increased until a discharge occurred and the desired current level was reached. They called this treatment a gas plasma discharge. Corn treated in this manner showed an increased germination rate when germinated in free water in a petri dish. Field trials with treated corn showed no advantage in yield from the treated seed. However, Brown et al. (6) found that treated seeds would absorb water faster.

Webb et al. (103) treated Empire cotton seed with a 60-cycle-per-second gas plasma discharge at 20, 40, 80, and 120 milliamperes. Gas pressure was 3 millimeters of mercury. They found exposed fuzzy and machine-delinted seeds showed a significant increase in germination rate although the total germination was not changed. Field tests with exposed seed showed no beneficial effects in yield or fiber quality due to the treatment.

Webb et al. (102) also exposed Empire cotton seed to a gas plasma discharge at currents of 20, 40, 80, and 120 milliamperes and frequencies of 500, 5,000, 10,000, 15,000, and 20,000 cycles per second. These

treatments caused exposed seed to germinate from 1 to 67 percent faster than control samples, but left total germination unchanged unless over treatment occurred. Over treatment reduced the total germination. All treatments caused significantly longer and heavier radicles to be developed after four days in a germinating chamber. Radicles from treated seed were about twice as long and heavy as those from untreated seed.

Brown et al. (6) found that over-exposure of seeds to a gas plasma discharge caused injury or death. The fatal dosage depended on the kind of seed and on individuals within a species. He found that treatment of a mixture of red clover and purple-top turnip and a mixture of smooth mustard and purple-top turnip could, if done under the correct conditions, kill the turnip seed and leave the mustard or the red clover uninjured.

Roseman et al. (85) found that gas plasma treatment would increase the water absorbing ability of rice. With time and pressure at 5 minutes and 2 millimeters of mercury respectively, maximum changes in the hydration characteristics occurred at 1/5 milliamperes for Zenith variety and at 150 milliamperes for Bluebonnet 50 rice. Exposure times over 45 minutes for Bluebonnet 50 and over 70 minutes for Zenith were inefficient in increasing the amount of water absorption when treatment was done at 50 milliamperes and 2 millimeters of mercury.

Hogan and Roseman (35) found that the water absorption capacity of rice could be increased equally by gas plasma treatment or by heating the rice to the same temperature as occurs in the gas plasma treatment. From this they concluded that the effect on water absorption of rice was due to heating and not necessarily the gas plasma treatment. However, in



1963 Roseman et al. (86) published results from studies on the lipids within the rice grain. They found that the rate of fatty acid development in the lipids of stored brown rice and stored bran separated from rice kernels was much slower in gas plasma treated samples than in controls. The average molecular weight of the oil extracted from treated rice bran was higher than that from controls and was less saturated. From these observations they concluded gas plasma treatment caused changes in rice seed other than those caused by heat.

Stone and Barrett (99) irradiated cotton yarn with a gas plasma discharge. They found that water uptake rate of the yarn increased, waxes in the yarn fibers were degraded, and damage was done to the primary cell walls. However, yarn strength increased from 31 to 76 percent.

Another method of treating seeds with electrical energy is to plant the seeds in soil and then pass current through the soil-seed mixture. Leicester (40) used this method to treat various kinds of seeds. He buried a 1-foot-square zinc electrode at one end of a 3 by 2-1/2 foot box of soil and a similar copper electrode at the opposite end. These were connected together by a wire, and various kinds of seeds were planted in the soil between. He found that seeds in the boxes containing the electrodes germinated and emerged "very much quicker" than those in the untreated boxes. In other experiments Leicester (41) used the same apparatus except he placed a Daniell cell across the plates. With this experiment he found that the growth rate of the young plant was greater in the treated plots than in the control plots until the food reserves stored in the seed were used up.

Lutkova (52) passed a direct current with a density of  $2 \times 10^{-10}$  to  $8 \times 10^{-6}$  amperes per square centimeter through soil for the entire growth period of the plants. He found that low current densities stimulated plant development. The starch content of potatoes increased 1 to 2 percent while yield increased 15 to 30 percent. Tomato yields increased 20 to 35 percent with fruit sugar content increasing by 0.3 to 1.0 percent. Sugar beets showed similar responses while cotton exhibited a larger number of reproductive organs. Electrification of soil, Lutkova believed, caused increased photosynthesis and decreased sharply the oxidation processes during crop maturation.

Lutkova and Oleshko (53) applied electric current to cherry seeds during stratification. Current intensities of 57 milliamperes per square centimeter shortened the time required for germination from about 100 to about 70 days. He related this to enzyme activity.

Kinney (38) studied the effects of electric current flow through moist seeds on germination and on radicle and hypocotyl growth rates. Thoroughly moistened seeds were placed in a glass tube about 2 inches in diameter for large seeds or about 3/4 inch in diameter for small seeds. Both ends of the tubes were closed with a copper disc and a voltage source, consisting of four Leclanche' cells connected through a 50-cycle-per-second Wagner interrupter and a Du Bois-Reymond induction coil, was connected across them. Seeds of white mustard (Brassica alba), red clover (Trifolium pratense), rape (Brassica napus), and barley (Hordeum vulgare) were soaked for 24 hours in water. Two hundred seeds of each variety were divided into eight lots of 25 seeds each. Seven of these

lots were treated with electricity for 2 or 5 minutes while the eighth lot was reserved as a control. Voltages ranged from 10-12 volts down to a fraction of a volt. After treatment the seeds were germinated at  $19 \pm 1$  degree centigrade. The results from these tests were summarized as the average number of seeds germinated in 24, 48, and 72 hours for the control and treated lots. In 24 hours the treated lots had 9.93 seeds germinated while the untreated lots had only 7.50, giving an increase due to treatment of 32.40 percent. In 48 hours 18.00 treated seeds and 14.87 untreated seeds had germinated. This is an increase of 21.05 percent due to the treatments. After 72 hours 19.14 treated and 18.00 untreated seeds had germinated; an increase of 6.33 percent in favor of the treatment. From this Kinney concluded that electrical treatment increased the germination rate. He also found that there exists a maximum, optimum, and minimum current level to influence germination and radicle growth rate. Hypocotyl growth followed a similar pattern.

Kinney (38) in other experiments found that small plants subjected to current flow through the soil for 30 seconds once every hour retained the stimulating effect of electricity. If only an initial treatment was given, the effect lasted only two or three days.

Shutt (90, 91), Russell (88), and Leighty and Taylor (42) all described the Wolfryn method of treating seeds with electrical energy. This process consisted essentially of placing seeds in a wooden tank filled with a weak salt (usually sodium chloride) solution. Iron plates were placed in each end of the tank and direct current electricity was passed through the salt water and seeds. Details of the process appear

to depend on who described it. For example, Shutt (91) specified 50 gallons of solution (1 pound of salt per gallon of water) was required to treat 10 bushels. A pretreatment of the solution with 6 kilowatts of electricity for 5 minutes was specified before placing the seeds in the tank. Electricity was then applied at a rate of 4 watts per gallon, and continued 4-1/2 hours for barley and oats, and 2-1/2 hours for wheat. Leighty and Taylor (42) on the other hand suggested using 8 watts of electricity per gallon of water with no pretreatment of the solution. However, they specified the grain should be soaked in the salt solution for 2 hours before turning the current on and 3-1/2 hours after turning the current on.

Various investigators (42, 90, 91) have indicated that the Wolfryn Process had little effect on crop yields, even though Shutt (91) stated the patentees of the process claimed increased yields ranging from 25 to over 100 percent. Leighty and Taylor (42) concluded from two years of statistically analyzed plot tests that the process produced no beneficial effects. Russell (88) reported yields from oats, wheat, and barley that had been subjected to the Wolfryn Process. He found yields ranging from increases of 92 percent to decreases of 54 percent. This led him to believe the process might have some validity but was too uncertain for use by farmers. Shutt (90) concluded after many plot tests that the Wolfryn Process did not increase crop production.

Wheelock (104) placed metal plates in the bottom of 1-gallon clay jars filled with water. Another plate was suspended in the water near the top of each jar. These plates were connected to a 110-volt direct

current power source. Corn or Durum wheat were placed in the water between the plates and subjected to 0.5, 1.5, 2, or 3 amperes for periods varying from 30 minutes to 5 hours. After treatment all the seed lots were dried, and following an 18-day period, were planted in pots in a greenhouse. With 28 lots of wheat and 32 lots of corn, no consistent differences in germination were found. In other tests corn and Durum wheat were planted 14 hours after treatment, but results from these tests showed no differences.

The study of seed germination as influenced by radio frequency (r.f.) electric fields has received considerable attention in the last few years. Nelson and Walker (73) placed seeds on a horizontal plate and suspended a second plate above the seeds. A radio frequency generator was connected across the plates. Results of experiments with wheat treated at 39 megacycles per second and exposure times of 4 to 37 seconds are shown in Figure 3. The dependence of this treatment on moisture content was clearly shown.

In other experiments Nelson and Walker (73) treated Nebraska 806 certified seed corn for five seconds at 40 megacycles per second. After two days in a moist chamber, the radicle lengths were significantly longer on the treated seed. Treatment of N6X420 single cross seed corn for 5 to 10 seconds in an electrical field of 2.5 kilovolts per inch and oscillating at 38 megacycles per second resulted in a significant increase in field emergence in limited field plots. Emergence increased from about 90 percent in controls to 95 percent in treated seeds. Similar treatment the following year on Nebraska 501 seed corn showed no differences. Prob-

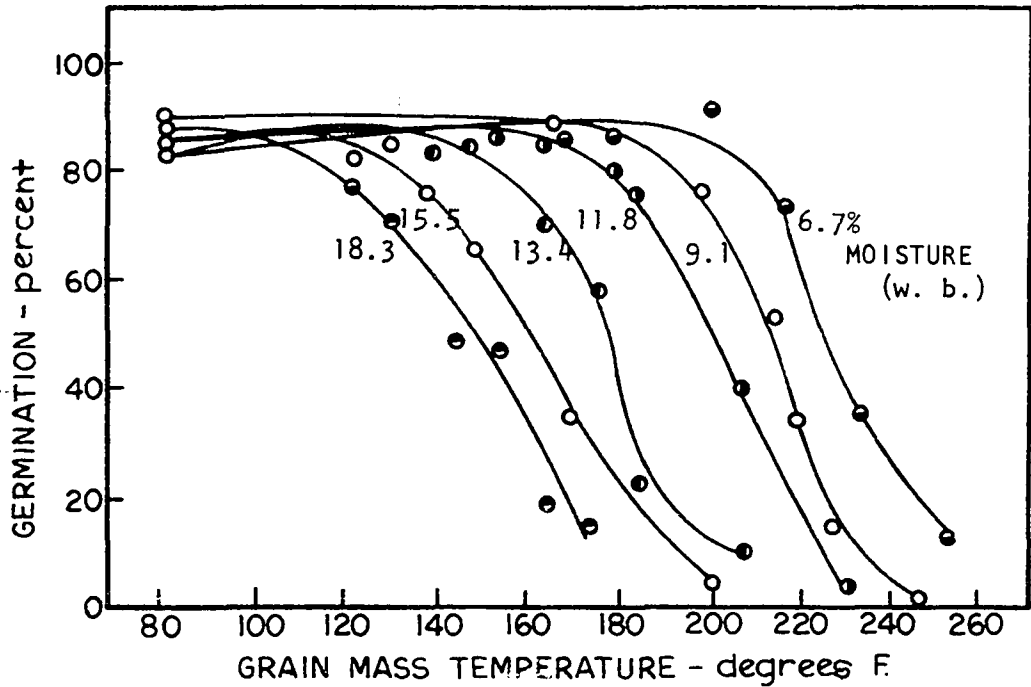

Figure 3. Tolerance of wheat, as indicated by germination, to radio frequency electrical treatment at the indicated moisture levels (wet basis), when exposure ranged from 4 to 37 seconds

ably because field emergence was high for both treated and control plots.

While working with Pennigft crown vetch, Nelson and Walker (73) found that treatment at a frequency of 43 megacycles per second and a field intensity of 3 kilovolts per inch for 24 seconds produced seed temperatures of 158 degrees Fahrenheit. This increased the germination significantly at the 1 percent level. Their attempt to kill smut on seeds failed since the seeds were killed at about the same temperature as the smut.

Jonas (37) treated seeds of carrots, onions, lettuce, and tomatoes with "high powered radio waves" of 43 to 44 megacycles per second. He found that the increase in germination rate depended on the voltage gradient, power and energy input, and the seed temperature. Nelson and Wolf (74) found that germination response of alfalfa seeds was similar when treated at 5, 10, or 39 megacycles per second.

Nelson and Walker (73) produced a reduction of the hard seed percentage in alfalfa and red clover by subjecting the seeds to a radio frequency electric field until the seed temperature reached 153 to 183 degrees Fahrenheit. Field intensity varied from 2 to 4 kilovolts per inch.

Nelson and Wolf (74) found that treatment of alfalfa seed with radio frequency electric fields reduced the hard seed percentage, increased total germination, and increased the water absorption of the seeds. For seeds of normal moisture content, treatment which produced seed temperatures between 160 and 170 degrees Fahrenheit gave the best results. For seeds with higher moisture contents lower temperatures were best, but lower moisture content seeds responded best to higher temperatures. They also found that after four years of storage the radio frequency treated alfalfa seed still exhibited a similar reduction of hard seed.

Nelson et al. (72) found that infrared, radio frequency, and gas plasma treatments were about equally effective in increasing germination of Ranger, Narragansett, and Du Puits alfalfa. These three treatments increased about equally the water absorption, conductivity, and oxygen uptake of samples in which hard seed was reduced. Jonas (37) found that

infrared irradiations produce smaller increases in germination than radio frequency treatment. He worked with carrots, onions, lettuce, and tomato seed.

Ark and Parry (1) in their review of literature on the use of high frequency electric fields in agriculture indicated high frequency fields have been used for insect control, stimulating plant growth, prolonging storage life of fruits and vegetables as well as other uses. They related McKinley's experiences with Golden Bantam corn. He found that 5 minutes to 1 hour exposures caused death of the corn seeds, 1 minute exposures caused slightly retarded germination, and 30 to 40 second exposure caused accelerated growth of seedlings during the early germination period.

Lower frequency electric fields have been used by many investigators in attempting to influence plant growth. Riccioni (83), after nine years of field experiments, developed a commercial process to treat grain with electrical energy. The operation used 1,000 hertz power and had a capacity of 10,000 pounds of grain per day. The grain was elevated to the top of the treating plant and was treated as it dropped to the ground through the treating chambers. The treating chamber consisted of three vertically arranged parallel plate capacitors separated by flow control mechanisms which controlled the grain flow through the capacitors. Grain velocity never exceeded 5 meters per second in the treating area. Spacing of the capacitors and voltage used were not specified, but he mentioned that his rectifying elements had a maximum of 2.5 amperes at 20 kilowatts. If operated at maximum conditions, they would rectify 8,000 volts. World War II interrupted Riccioni's work, and to this author's knowledge it was never revived.



Results from seed planted after treatment at Riccioni's commercial plant were not reported. However, in his laboratory experiments a similar apparatus, only on a smaller scale, was used to treat some seeds. Results reported from these experiments showed yield increases ranging from 2.2 to about 37 percent. Some yield decreases were also reported, but he felt they were caused by other specific factors such as land variations and weather conditions.

Roane and Earp (84) placed spinach seeds between two 6x6-inch plates 1 inch apart and subjected them for 30, 60, or 90 seconds to an electric field oscillating at 60, 500, or 900 cycles per second. After 31 days in a germinating chamber at 45 degrees Fahrenheit, no difference could be detected in germination between any treatment and the control.

Smirnova and Tiutunnikova (95) developed a commercial processing plant to treat seeds with electric energy. The plant's design capacity was 1.5 to 2 tons per hour. Treatment consisted of dropping seeds through a parallel plate air capacitor charged to a high voltage. Exposure time was varied by changing the length of the capacitor plates. They reported results from treating biannual lupin, annual lupin, corn, barley, buckwheat, oats, and peas. The treatment consisted of subjecting the seeds to voltage gradients of 1 or 2 kilovolts per centimeter with exposure times of 10, 20, 30, 60, or 120 seconds. Their results showed the following increases in grain yield: oats and barley, 10 to 15 percent; buckwheat, 8 to 10 percent; peas, 13 percent; lupin, 2.5 percent. Green mass increases of 15 to 20 percent over control plots were reported for corn. From tests designed to determine the storage life of the treatment effect, they concluded that storage for at least one month was practical.

The frequency of the electric field used was not explicitly stated but appeared to be 50 cycles per second.

Sidway (92) treated lettuce seeds between two aluminum foil electrodes set 0.5 centimeters apart. The seeds rested on the bottom plate. Power was supplied to the plates from two 90-volt batteries connected in series giving a potential of 180 volts across the plates. In tests with over 150 replications he found that with the bottom plate negative the treated seeds had 4.9 percent lower germination than control samples. If the bottom plate was positive, the treated seeds had 1 percent higher germination than the controls.

Murr (66) planted yellow bush beans in soil which was between capacitor plates charged with 60-cycle-per-second current. The soil rested on the cathode while the anode was suspended 12 inches above the soil. The following results were observed: with a field strength of 20 kilovolts per meter 89 percent germinated, 40 kilovolts per meter produced 96 percent germination, 60 kilovolts per meter produced 78 percent germination, and 80 kilovolts per meter produced 96 percent germination. The control had 90 percent germination.

Murr (68) in other tests subjected seeds of grain sorghum, wax beans, and corn, which were planted in soil, to vertical electrostatic and 60-cycle-per-second electrokinetic fields. Field strengths varied from 20 to 80 kilovolts per meter. His results which are given in Table 2 showed no significant trends.

Table 2. Germination characteristics<sup>a</sup>

Plant type	Field characteristic	Potential gradient	Percent germination	
			Active	Control
Grain sorghum	Electrostatic	40	65	68
		60	37	41
		80	76	76
Grain sorghum	Electrokinetic (60 c.p.s.)	25	70	70
		50	65	69
		75	78	77
Wax bean	Electrostatic	20	54	86
		40	35	37
		60	92	97
Wax bean	Electrokinetic (60 c.p.s.)	40	96	93
		50	88	94
		60	72	90
		80	96	90
Corn	Electrostatic	25	89	89
		50	100	95
		75	61	61
Corn	Electrokinetic (60 c.p.s.)	25	96	96
		50	80	90
		75	96	94

<sup>a</sup>Taken from Murr (68).

Correlation and Explanatory Studies  
of Bioelectric Potentials

Burr (8-18) appears to have been one of the first investigators to attempt to develop a relationship between the seemingly unconnected observations previously discussed. The essence of his efforts were condensed and stated as follows by Burr (16, p.330):

The pattern or organization of any biological system is established by a complex electro-dynamic field, which is in part determined by its atomic physico-chemical components and which in part determines the behavior and orientation of these components. This field is electrical in the physical sense and by its properties it relates the entities of the biological system in a characteristic pattern and is itself in part a result of the existence of these entities. It determines and is determined by the components. More than establishing pattern, it must maintain pattern in the midst of a physico-chemical flux. Therefore, it must regulate and control living things, it must be the mechanism the outcome of whose activity is "wholeness," organization and continuity.

He went on to state that the fate of any cell was determined by its genetic constitution, a certain cellular environment, and a certain position in an electrodynamic field. The various steps in ontogeny were, Burr (11) claimed, not causally related links in a chain of events, but were common expressions of a single regulating principle. Northrop and Burr (76) clarified the theory when they stated that bioelectric fields were not only the result of chemical processes but the fields helped regulate the chemical processes. The electric fields Northrop and Burr (76) claimed coordinate the chemical reactions to maintain a living organism.

Burr supported his theory on the basis of much experimental work which he and other investigators had done. Much of the support he cited

evolved from correlation studies between growth and organization and the observed bioelectric potentials.

Nelson and Burr (71) studied the bioelectric potential existing between the point and crown end of corn kernels. They found the potential measured in the first few seconds of contact with the kernel was directly correlated with seed viability. The higher this potential, the greater the probability of seed germination. The potential observed 30 to 120 seconds after electrode contact was labeled the "Equilibrium Potential." This potential was lower than the initial or "Prime Potential," and was found to be directly correlated to plant growth after emergence--the higher the potential, the greater the growth. Field tests showed significance at the one percent level for both the "Prime Potential" and "Equilibrium Potential" when these potentials were used to sort the seed corn before planting.

Dexter (26) found that by impressing a 6-volt direct current potential across corn seeds and measuring the conductance he could with a high probability determine the dead seeds. He found that the higher the conductance, the greater the probability of the seed being dead.

Burr (10) while measuring the potential along the long axis of a corn kernel found the potential difference was correlated with hybrid vigor. Different inbred strains of sweet corn differing only in one gene showed a significant difference in potential. Burr (14) stated that the higher the potential measured, the more vigor the resulting plants showed. Similar studies by Burr (12) on cotton seed showed that the higher the seed potential, the more rapid the germination of the seed.

Burr and Sinnott (18) studied the potential differences measured

along the axial and equatorial diameters of developing fruits of three races, designated as elongate, round, and flat, of Cucurbita pepo. The size of the potential differences had little relationship to the absolute size of the dimensions along which they were measured, but the ratio of the potential differences was closely correlated with the ratio of the dimensions. As the fruits grew larger, the potential gradients tended to decrease in all races, but the ratio of the gradients in the two dimensions tended to increase in the elongate race, decrease in the flat race, and remain unchanged in the round race.

Burr (14) measured the potential in the trunk of maple, elm, and oak trees. He found standing potentials which varied in cycles. These variations were not related to temperature, barometric pressure, or humidity. He detected at least three sets of cycles, a 6-month cycle, a 3-month cycle, and a 28-day cycle. The causes of these cycles were unknown.

Marsh (54) found that the smallest externally applied current which would produce a visible change in growth of an onion root was less than the current produced by the root. Thus, the current produced by the root was sufficiently large to affect growth of the root.

Lund (44) studied Obelia and found that the outer ectoderm was positive with respect to the endoderm. By setting up a potential across the stem of Obelia which opposed the ectoderm potential, he was able to inhibit growth. He concluded that growth inhibition was due to neutralization of the normal ecto-endoderm voltage. A voltage impressed perpendicular to the stem axis caused the stem to grow toward the anode. Potentials of 0.05 to 0.1 times those needed for growth inhibition produced growth

orientation. Lund (44) concluded from his studies that the electric potentials possessed by cells could have been the force controlling direction and differentiation in growth since the potential required (about 0.5 millivolts) to orient growth is well below the potential generated by cells.

Larson (39) concluded from his studies of the bioelectric potentials surrounding roots of Zea mays that the continuous bioelectric potentials might play an important role in the oriented growth of the plant.

Wilcox et al. (105) found that tomatoes inoculated with Phytopomonas tumefaciens showed a decrease in their bioelectric potential as compared to uninoculated plants. The potential was measured across the stem of the plant. The decrease in potential was first observed about 16 days after inoculation and 5 days before the tumors were visible.

Burr also studied the bioelectric potentials in animals. While studying chicks, Burr and Hovland (15) found that a potential exists between the head and tail of chick embryos during the first 72 hours of incubation. This potential made it possible to determine the location of the head of the chick without breaking the egg. Burr's (14) work on salamander and frog eggs showed similar bioelectric potentials. The head of the organism was always located at the point of highest potential.

Burr (14) found that mice exhibited an increasing potential during the first 1/3 of their life, a relative constant potential during the middle 1/3 of their life, and a decreasing potential during the final 1/3 of their life. Burr's (8) studies on cancer in mice and in humans showed that cancer caused marked changes in the bioelectric potentials of the infected organism.

Burr and Northrop (17) found that several factors influenced the magnitude of the bioelectric potential found in an organism. Among these are growth and development, local injuries, activity of generative tract associated with ovulation, heart and brain waves, and the development of cancer. Parkinson (77) found that the concentration of the solution in which plant cells were immersed would influence the observed potential.

In his studies on the bioelectric potentials in corn roots, Burr (9) showed that cell division was accompanied by a steady but slowly rising potential. Differentiation was, however, accompanied by a fluctuating potential with no apparent pattern. Injury in plants, Burr (13) showed, was accompanied by the generation of a high potential surge which travels throughout the plant in a manner similar to a nerve impulse in an animal.

Burr's theory mentioned above postulated that the bioelectric potentials of an organism were the regulating mechanisms which control the organization of the organism. However, his theory and investigations never attempted to isolate the source of the bioelectric potentials. Several investigators have attempted to explain their source as asymmetric distribution of growth regulating compounds. However, most of the experimental work appears to refute this theory.

Clark (22) discovered that with sections of Avena coleoptiles polar heteroauxin transport was specifically abolished with 1 part of sodium glycocholate in 100,000 parts water without any change occurring in electrical polarity, respiration, semi-permeability, growth by cell elongation, or protoplasmic streaming. Lateral and longitudinal transport of heteroauxin in plants was found to be caused by two completely different mechanisms. Clark (22) concluded from this study that electrical



polarity, expressed in terms of inherent potential differences, had no causal relation to auxin transport in plants.

Clark (23) applied a potential across a section of Avena coleoptile and observed the longitudinal heteroauxin transport. Even though the applied potential reversed or increased the inherent electrical polarity of the section, he found that it had no effect on heteroauxin transport. Inverted polarity induced by gravity also showed no effect on longitudinal auxin transport. He concluded that either electrical polarity had no cause and effect relation to auxin transport or this relation was not amenable to treatment by the methods he used.

Naqir et al. (70) studied auxin transport in corn coleoptiles under both anaerobic and aerobic conditions. Anaerobic conditions were more favorable to gravity-induced asymmetric transport of indoleacetic acid in horizontal coleoptile segments than were aerobic conditions. Since geoelectric potentials were not produced under anaerobic conditions, it was concluded that geoelectric potentials were not always present when asymmetric auxin distribution existed. Anaerobic atmospheres reduced auxin absorption to approximately 1/2 its normal value, but had only slight effect on auxin transport.

Parkinson and Banbury (78) concluded that bioelectric potentials are not the cause of longitudinal auxin transport since the plant apex can be slightly positive or strongly negative with respect to the growth medium.

Wilkins and Woodcock (106) set up a lateral gradient of indolyl-3-acetic acid across a vertical section of a Zea mays coleoptile. They found that the side of the coleoptile with the highest concentration developed a surface potential of at least 10 millivolts positive with

respect to the opposite side. From this study they concluded that different concentrations of indolyl-3-acetic acid in different parts of a plant stem caused a potential to develop between the two points.

Dedolph et al. (25) studied the geoelectric and geotropic effects in Zea mays. Their work indicated that auxin was required for both of these effects. The geoelectric effect was not present under anoxia (nitrogen atmosphere), but the geotropic effect was. The geotropic effect was virtually eliminated by removal of the coleoptile tip, but the geoelectric effect was not disrupted. Thus, the geotropic effect appeared to be linked to something in the coleoptile tip while the geoelectric effect appeared to be related to a metabolic process.

Lund (47) in 1928 proposed his oxidation-reduction theory which links bioelectric currents with animal and plant respiration processes. The basic concept behind his theory was explained by Lund (47, 49) as an oxidation-reduction process operating at a single locus in a cell. A simple oxidation-reduction potential dependent on two types of reactants at any single locus in a cell was expressed as:

$$E = E_o - \frac{RT}{nF} \ln \frac{[\text{ox.}]}{[\text{red.}]} \quad (1)$$

where:

E = bioelectric potential

$E_o$  = constant

R = gas constant

T = absolute temperature

n = the change in valence of the ion involved in the equilibrium

F = the Faraday

[red.] = concentration of reductant

[ox.] = concentration of oxidant

The known facts of cell metabolism justified Lund in assuming that cell oxidation consisted of an ordered series of consecutive linked chemical reactions. He assumed the minimum number of reactions in the aerobic process could be represented as:

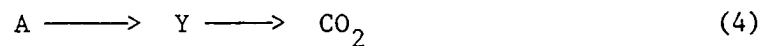
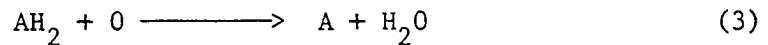
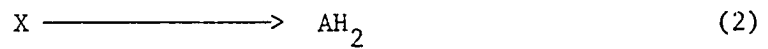

where:

X = base substance from which  $AH_2$  and A is made

$AH_2$  = reductant

A = oxidant

Y = intermediate compound(s)

O = oxygen

Reaction 2 represented the intracellular process resulting in the formation of reductant  $AH_2$  whose concentration at any time and at any particular locus in the cell depended on the local rate of formation of  $AH_2$  from X and on the rate of oxidation of  $AH_2$  by oxygen.

Lund (48) showed that the velocity of cellular oxidation in frog skin is proportional to the oxygen concentration. This required that oxygen be introduced into Equation 1. Lund (47) did this in the following manner:

$$E = E_o - \frac{RT}{nF} \ln \frac{(A)}{(AH_2)(O)} \quad (5)$$

This equation described the dependence of the bioelectric potentials on oxygen concentration.

Lund (45) found that living tissues have a bioelectric potential associated with them but dead cells do not. In living Obelia stems he observed variations along the length of the stem in the magnitude of the potential differences measured across the stem.

Clark (21) observed cut sections of Avena and Zea mays coleoptiles and Pisum and Vicia stems. All of these exhibited apical negativity and a bioelectric potential which is directly proportional to the length of the sections. Lund et al. (49) also observed that the potential generated by cells was often additive in tissues.

Marsh (54) passed electric current through a living onion root. If the applied potential opposed the inherent potential of the root, the root voltage increased. If the external voltage was in series with the root voltage, the inherent potential decreased. The smallest applied current which caused a visible change in the root was less than the current generated by the root. Removal of the external potential caused the inherent potential to undergo recovery to its former state. The equation of the characteristic recovery curve was developed from consideration of the velocity of the chemical reactions in Lund's oxidation-reduction model.

Lund (48) explained the relation of these continuous bioelectric potentials on the basis of his oxidation-reduction theory. He considered

each end of the cell as a locus of an oxidation-reduction reaction.

Thus, each end of the cell could be mathematically described by Equation

5. Subtracting the basal cell potential from the apical cell potential gave the following equation:

$$E_{\text{apical}} - E_{\text{basal}} = \frac{RT}{nF} \left( \ln \left( \frac{(A)}{(AH_2)(O)} \right)_{\text{basal}} - \ln \left( \frac{(A)}{(AH_2)(O)} \right)_{\text{apical}} \right) \quad (6)$$

This equation gave the potential across a cell. Since the cellular potentials had been shown to sum, the cellular potential given by Equation 6 was summed over the tissue to give the continuous bioelectric potentials which were observed.

From the work of several investigators, considerable evidence has accumulated which indicated that bioelectric potentials have their source in the respiration processes.

Lund (46) showed that treatment of frog skin with cyanide reduced the bioelectric potentials and the velocity of cellular oxidation to 40 percent of its normal value. However, sufficiently high oxygen concentrations neutralized the depression of electric polarity in frog skins produced by concentrations of  $2 \times 10^{-5}$  molar potassium cyanide. Lund (46) found that the rate of metabolism, as measured by oxygen consumption and carbon dioxide evolution, was higher in the apical region than in the basal region. Electric polarity across the ecto-endoderm layer and the velocity of cellular oxidation were depressed more in the apical regions than in the more basal regions by the same concentration of potassium cyanide. The percent depression of electric polarity by cyanide depended on the cyanide concentration in frog skin.

Lund (48) showed that the velocity of cellular oxidation was proportional to oxygen concentration. After the oxygen concentration became zero, the electric polarity of a frog skin was maintained for a considerable period by anaerobic respiration. After this period the potential drops to zero and was taken by Lund (48) to be the death of the cells.

Fensom (31) studied the potential in the trunk of trees. He found that applications of 2,4-D (2,4-dichlorophenoxyacetic acid) at 100 parts per million caused the potential, measured between two points separated vertically by 150 centimeters along the trunk of the tree, to increase. Applications at concentrations of 10,000 parts per million caused the potentials to drop and eventually to reverse polarity. Etherton (28) showed that addition of 2,4-dinitrophenol (DNP) to the external solution reduced the potential difference across coleoptiles of Avena.

Siniukhin (94) while studying tomatoes found that the bioelectric potentials in the cells of a callus exhibited a high potential during the initial stages of formation. Initiation of the formation of accessory growing points also was characterized by high potentials. In conclusion he stated that an externally applied potential could accelerate the regeneration process in the cells of a tomato stem if due regard was given to the optimum dosage and the natural electropolarity of the stem.

Hyman and Bellamy (36) concluded from their studies that the differences in continuous bioelectric potentials which existed along the main axis of animals were due to differences in the metabolic rate in the different regions. Regions of highest metabolic activity were electropositive to the areas of lower metabolic activity. Fensom (30) concluded that the

bioelectric potentials were a result of metabolic processes within the plant.

Priestley (82) cited work done by Pollacci in which he reported electricity increased the chemical activity of plants. Larson (39) reported a bioelectric potential-temperature relationship in Zea mays roots. Between 18 and 38 degrees centigrade the bioelectric potential was directly related to temperature. Below 18 degrees centigrade and above 38 degrees centigrade the potentials were very much reduced as was the growth rate. This suggested an enzymatic system was involved in the production of bioelectric potentials. Plowman (80) also noted this temperature effect on the potentials.

Lutkova (52) passed current through soil with cherry seeds imbedded in it. He showed that the activity of the oxidation-reduction enzymes catalase and polyphenoloxidase was increased by the passage of current through the seed. Catalase activity was closely connected with the growth processes while polyphenoloxidase was concerned with the oxidation-reduction conversions of ascorbic acid. Activity of the respiration enzyme peroxidase was also increased in the treated seeds.

Blackman (2) and Blackman and Legg (3) did some calculations on the energy supplied by electricity compared to the energy-trapped by the increased growth of the plant after electrical treatment. Both authors concluded that electricity was a stimulating force since the energy supplied by electricity was only about 0.2 percent of that absorbed by the plant from sunlight. The increased yield averaged about 20 percent in Blackman's work (2). Blackman (2) also mentioned that it must be a

metabolic effect since the electrically treated plants appear to be a darker green in color.

Lund and Kenyon (50) showed that in roots of Allium cepa, Eichhornia crassipes, and Narcissus the regions of highest positive potential had the highest capacity to reduce methylene blue. Regions of lower electro-positivity showed correspondingly smaller capacities for reduction of methylene blue. The rate of respiration also was correlated with the magnitude of the positive potential.

Lund et al. (51) concluded from their studies that the electrical energy generated in the onion root tip and in frog skin appeared to be derived from the oxidation-reduction mechanism of the respiratory process. This consisted of an oriented electron transfer mechanism unique in magnitude at each spot along the root or on the skin. Their studies also showed that exposure of the frog skin or onion root tip to carbon monoxide reduced the respiration rate at any point in proportion to the normal respiration rate at that point. This plus the knowledge that carbon monoxide tends to inhibit the action of cytochrome oxidase led them to conclude that their oriented electron transfer system was the cytochrome system. Orientation of this system explained the principle of summation of potentials which various investigators mentioned above have observed.

Murr (60-69) grew plants in high voltage electrostatic and 60-cycle-per-second electrokinetic fields. He observed leaf tip damage and other unusual phenomena as a result of the electric fields. On the basis of his experiments, Murr (62) stated what he believed was the mechanism of action causing the plant-cell damage in the electric field. Murr (62, 63)



observed increased concentrations of iron, zinc, and aluminum in the damaged leaf tip of orchard grass grown in an electric field. In golden sweet corn and yellow bush bean leaves grown in an electrostatic or a 60-cycle-per-second electrokinetic field, Murr (60) found increased concentrations of aluminum.

The significance of these increased concentrations was definitely related by Murr (62) to an increase in the metabolic enzyme concentrations within the plant cells. His conclusion was that the damage mechanism responsible for plant destruction in an electric field is a biochemical enzyme activity which initiates abnormalities in cell respiration and related metabolic processes.

In a later paper Murr (60) expanded his theory further. Plants growing in an electric field were subject to two types of disruptive actions. First, there was the stimulation of the cells to produce larger amounts of respiratory enzymes. Small increases in the concentrations of these often were beneficial to the growth rate of the plant. However, many of these enzymes were toxic to the plant at higher concentrations. Thus, high levels of stimulation could have been somewhat harmful to the plant. This could explain many of the apparent contradictions in the results reported by various investigators. Secondly, there was a polarization of the epidermal and subepidermal chemical components. The electric field exerted an attractive force for these polarized components. If this attraction was stronger than the mechanical strength of the epidermal cells, rupture of the cells occurred with accompanying ionization-evaporation of the epidermal tissue components and polarized protein

molecules. Rapid dehydration ensued. Loss of enzymes caused enzyme production to be accelerated which overloaded the respiratory system and ended in collapse of the respiratory mechanism. This collapse plus internal dehydration and cell plasmolysis lead to death of the damaged cells.

The increases in the amount of minor elements Murr (62, 63) found in damaged tissues supported his theory since many respiratory enzymes were bound to proteins through a metal atom. Other respiratory enzymes such as cytochrome c, oxidase, catalase, and peroxidase contain a porphyrin which has a metal atom in the center of it.

Blackman and Legg (3) and Murr (62) both observed that plants grown in an electric field were darker green in color than were control plants. Murr (62) explained this in light of his work as a breakdown by oxidation of a typical porphyrin. Ozone produced by the electric field could attack the porphyrin and open its ring in the alpha position. This produced a deep-green pigmented porphyrin which gave the plants their dark-green color.

Comparison of Lund's and Murr's work summarized above indicates that both of them arrived at the same general conclusion. The effect of electricity on plant growth appeared to them to be through disruption or stimulation of the oxidation-reduction or enzymatic reactions taking place in respiration. Lund et al. (51) suspected the cytochrome chain was the primary source of bioelectric potentials while Murr (60) indicated only that metal-containing enzyme systems were involved, particularly a system containing aluminum. The cytochrome chain which figured largely in Lund's

et al. (51) hypothesis does contain several metal-containing enzymes.

Three other possible sources of electric potentials have been discussed by various investigators. Waller (101) showed that an electric current is generated in a leaf when part of the leaf is illuminated and part kept shaded. Glass (33) working with isolated Elodea leaves found that illuminating one part of the leaf caused the potential of the illuminated section to increase sharply with respect to the shaded section.

Scott (89) investigated the causes of bioelectric potentials in plants and concluded that ion movement within the plant set up minute electric fields about cells. Under favorable circumstances these minute potentials summed over a tissue to give an electric field of observable magnitude.

Scott (89) suggested a second possible source of bioelectric potentials in plants. Developing tissues often synthesized organic acids from neutral sugars. In the process positive hydrogen ions were given off and the charge replaced by cations such as potassium, sodium, or calcium. Thus, if hydrogen ions left the plant from a point different from the point of absorption of potassium, sodium, and calcium, a potential would exist between these two points, and current would flow in any conducting medium connecting them.

#### Summary

It appeared that the response of plants to treatment with electrical energy was quite varied. Response was affected by several factors, among

which were the type of plant, species of plant, stage of development of the plant, method used to apply the energy, duration of energy application, intensity of energy application, and other factors. The mechanism of action appeared to be best explained by the theories of Lund et al. (51) and Murr (62). These indicated electrical energy acts on the chemical reactions taking place in the respiration of the organism.

In view of the number of variables involved, the complexity of the variables, and the apparent contradictions between the results of different investigators, it is obvious that further research in this area must be done before practical means can be developed to use electrical energy for controlling plant growth. The first step should be the definition of the relationship between plant response and each of the variables. The research described below attempts to define this relationship for the intensity and duration of application of electrical energy when the energy is applied to corn and soybean seeds through an electrical field.

## APPARATUS

The treating machine used in this investigation is shown in Figures 4 and 5. Figure 4 shows the variable speed drive motor, the seed metering device and the treating chamber. The model 9M168 A.C./D.C. Dayton gear motor is driven through a model KG 201 Knight motor speed control. The motor has 1/15-horsepower at 5000 revolutions per minute. The treating conveyor belt is driven by the motor through a model 4K871 Dayton gear head which gives a 100 to 1 speed reduction. The belt rides directly on the 1/2-inch diameter shaft extending out of the gear reducer. The opposite end of the seed treating belt is carried by a 3/4-inch diameter idler pulley.

Figure 5 shows the drive arrangement for the seed metering device. The treating belt idler shaft extends to the right to a third bearing. This extension drives a 9/16-inch diameter pulley which in turn drives, by means of a heavy rubber band, the main drive pulley of the metering system (Figure 6). This pulley is 1-1/2-inches in diameter and powers the seed metering plate by means of a six to one speed reducer and a set of bevel gears. Thus, for every rotation of the seed plate the treating belt drive shaft must turn 23.7 revolutions.

The seed metering mechanism, shown in Figures 4 and 5, is patterned after a conventional planter metering system. A plexiglass plate 1/2-inch thick and containing a slot 5/8-inch wide was mounted on top of the seed plate drive mechanism and in such a position that the slot was located approximately 1/16-inch directly above the seed treating belt. The plexiglass seed metering plate was 5 inches in diameter and 3/16-inch

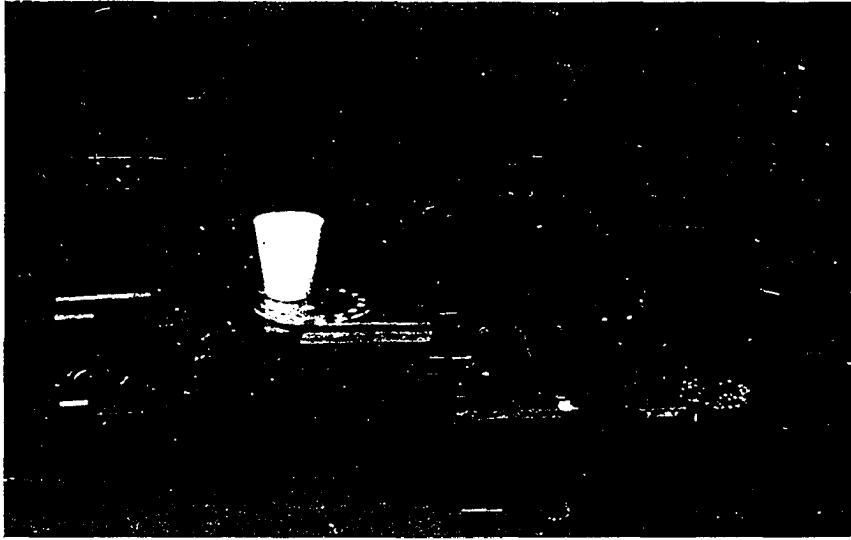

Figure 4. Treating chamber with metering system for dry soybean seeds

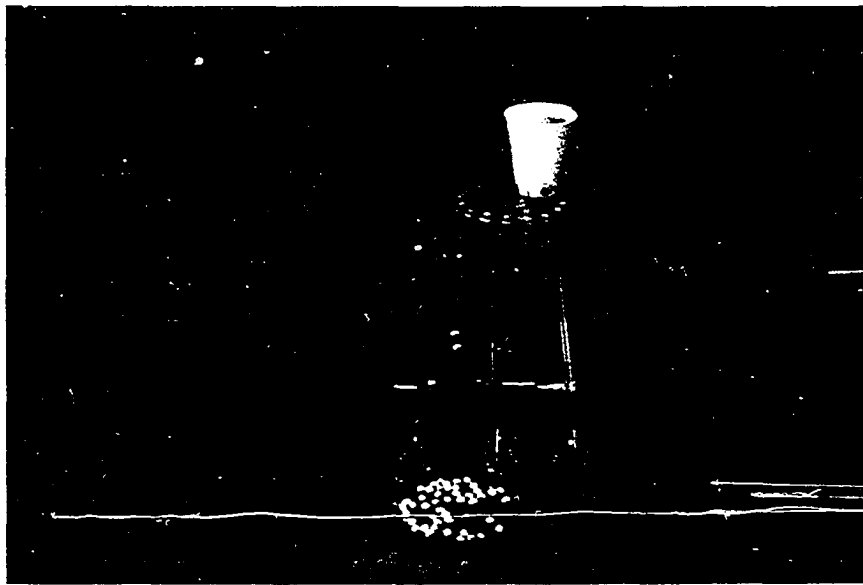

Figure 5. Treating chamber showing the power train to the dry soybean seed metering system

thick. Sixteen 3/8-inch diameter holes were drilled through the seed plate at equal intervals along a 4-inch diameter circle. These holes acted as seed cells. The metering plate was mounted to the vertical shaft extending out of the seed plate drive mechanism and through the slotted plexiglass plate. Adjustments were made until the clearance between the slotted plexiglass plate and seed plate was less than 1/64-inch. To eliminate hand feeding, a styrofoam drinking cup with the bottom removed was mounted over the seed plate to serve as a seed hopper.

The treating chamber is shown in Figure 4, and consists of two stainless steel plates 2-inches by 5-inches mounted vertically on two 3/16-inch thick plexiglass plates. These plates were separated by 1-1/2-inches of air except where the seed treatment belt passed between them. This belt was made of 1/4- by 1-inch weather stripping and carried the seeds through the electric field set up between the stainless steel plates. The belt did not materially change the electric field from that of a parallel plate air capacitor.

The treating chamber plates were charged by either direct current or 60-cycle per second alternating current. Direct current was supplied from the high voltage power supply of a Hycon type CA-2521 cathode ray oscilloscope. A variable transformer, Powerstat type 116B, was placed in the 115 volt alternating current supply line for the oscilloscope, and provided a variable direct current output voltage from the oscilloscope. Alternating current was supplied by placing a variable transformer, Powerstat type 116B, in series with a General Electric luminous tube transformer capable of 6000 volts at 30 milliamperes. Plate voltage was

continuously monitored by a model 630 Tripplet volt-ohm meter. Figure 7 shows the wiring diagram for the electrical equipment.

Soaked soybean seeds were so soft that the metering system shown in Figures 4 and 5 damaged the seeds. A belt type metering system was developed which caused less damage to the seeds. The system developed is shown in Figure 8. A variable speed A.C./D.C. motor drives a belt with seed cells cut in it through a seed hopper and up an inclined plane. The motor is a model 4K862 Dayton right-angle drive gear motor. This 1/15-horsepower, 5000 revolutions per minute motor drives a 238 to 1 gear reducer. A 1-1/4-inch diameter pulley on the gear reducer output shaft drives the metering belt. Variable output speed is achieved by powering the motor through a variable speed motor control, a Speedial Mark II. The metering belt is a piece of 1/4 by 1-inch weather-stripping which has holes, 9/16-inch diameter when metering wet soybeans and 1/2-inch diameter when metering wet or dry corn, punched entirely through it. A piece of 1-inch wide canvas tape was placed on the bottom side of the weather stripping to give it strength and to close one end of the holes and form seed cells.

One side of the metering machine seed hopper can be positioned at any angle between 15 and 60 degrees relative to the horizontal by means of thumb screws. The seed belt runs inside of the hopper and parallel to this movable side of the hopper. Figure 9 shows a more detailed view of the seed belt picking up beans from the hopper. The angle of inclination is adjusted so that only one seed stays in a seed cell while all other seeds roll off the belt and back into the hopper.



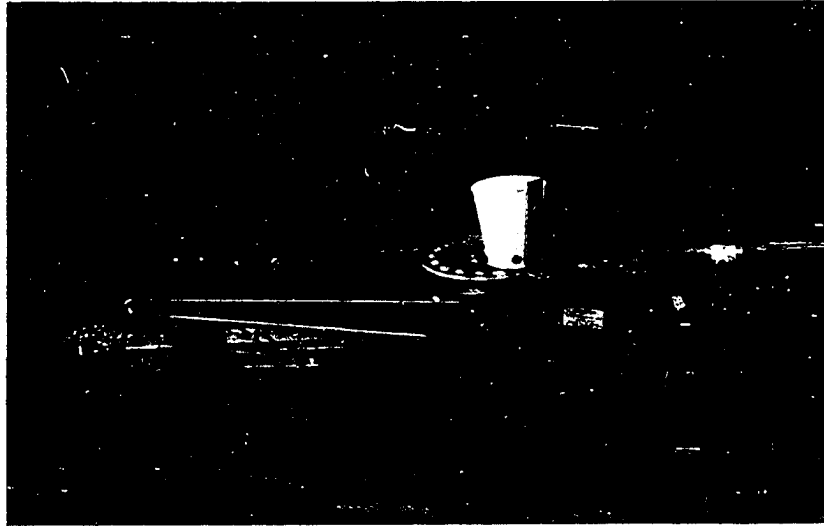

Figure 6. Treating chamber showing the entire drive mechanism for the dry soybean seed metering attachment

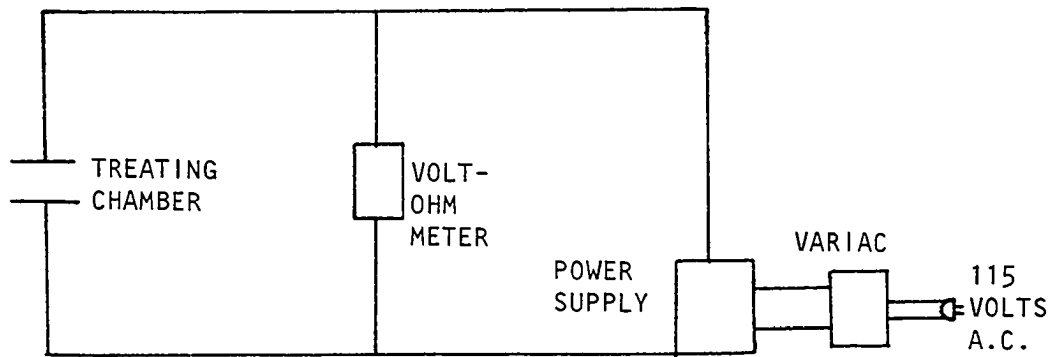

Figure 7. Schematic wiring diagram for treating chamber

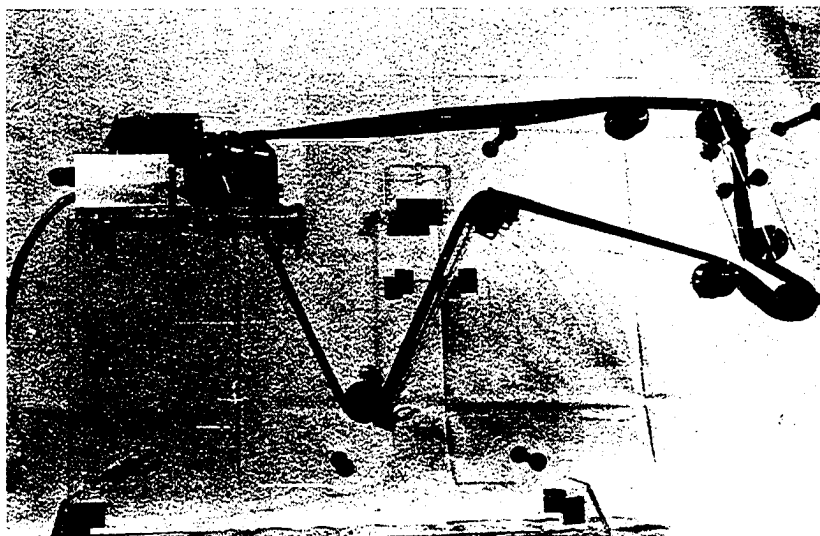

Figure 8. Belt type metering system

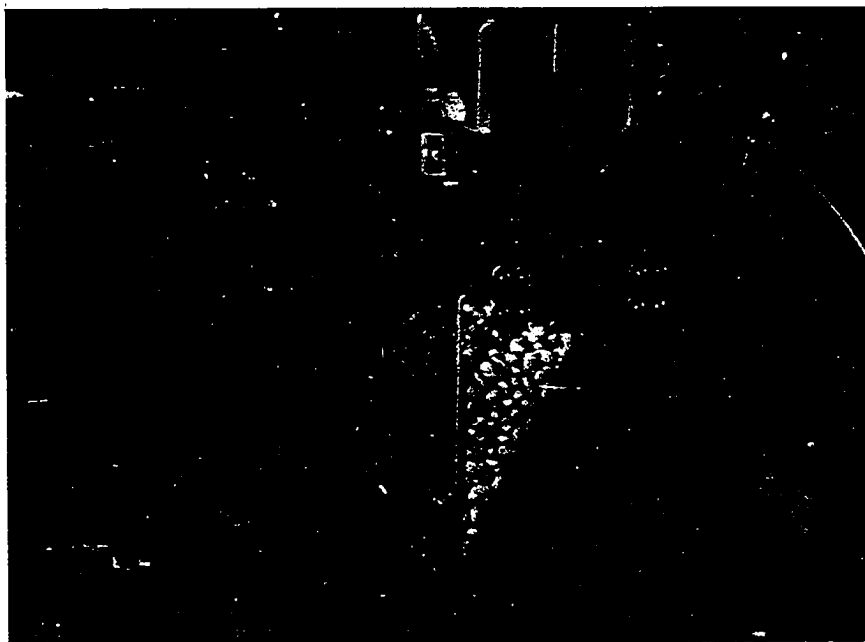

Figure 9. Detail of seed hopper and metering mechanism

Figure 10 shows a detailed view of the belt metering machine emptying into the treating machine. The seed belt undergoes a 180 degree rotation between the two pulleys located directly above the funnel in Figure 10. This allows the seed to drop out of the seed cells and into the funnel which directs the seeds onto the seed treating conveyor belt. Figure 11 shows the belt metering machine and the seed treating machine in operation.

One-fourth-inch-thick plexiglass was used to construct all the plastic parts of the belt metering machine except the motor mounting plate which was 1/2-inch-thick plexiglass. The sides of the machine were held 4-inches apart by metal spacers. All of the pulleys were mounted in 1/4-inch diameter ball bearings except for the drive pulley which was supported by brass bearings in the gear head housing.

The chamber used for germinating the seeds was a walk-in cooler with inside dimensions of 111 by 65 by 82-inches. Humidity was maintained within the chamber at  $95 \pm 3$  percent by the steam generating system shown in Figure 12. One tank 4-inches high by 6-inches wide by 14-1/2-inches long was constructed of galvanized sheet metal. A 3/8-inch diameter pipe was soldered in the center of one side of this tank and 4-1/2-inches from the bottom. The other end of the 2-inch-long pipe was soldered into another tank also constructed of galvanized sheet metal and having dimensions of 4 by 4 by 14-1/2-inches. A 230-volt 1200-watt water heater element was mounted in this second tank and connected to a 115 volt alternating current source. Thus, the element produced 300 watts and kept the water in this tank boiling continuously. In order to control the water level in this tank, a toilet valve was placed in the larger tank.

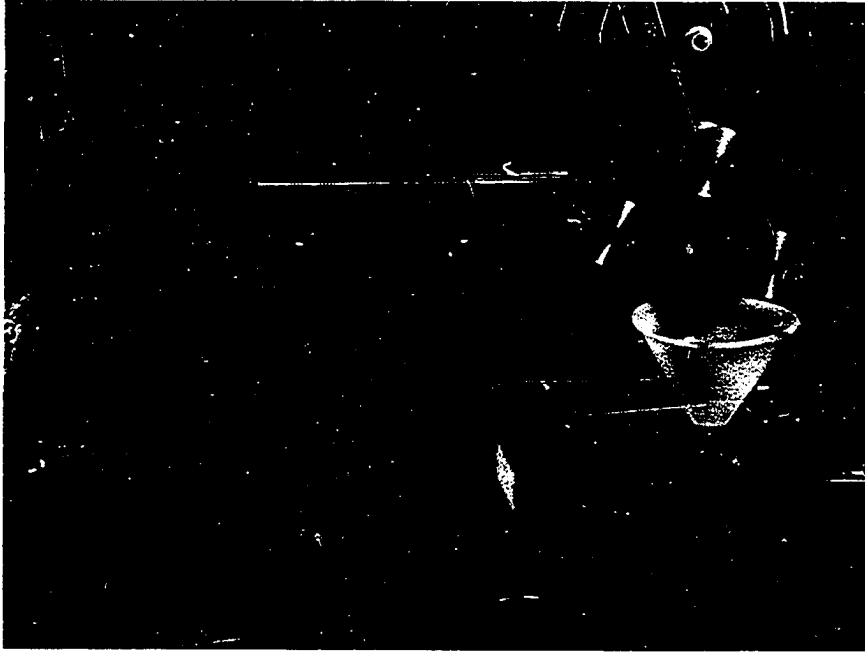

Figure 10. Detail of seed release mechanism



Figure 11. Operation of the belt type metering machine, treating chamber and associated electrical equipment when treating soaked soybean seeds in an alternating electric field

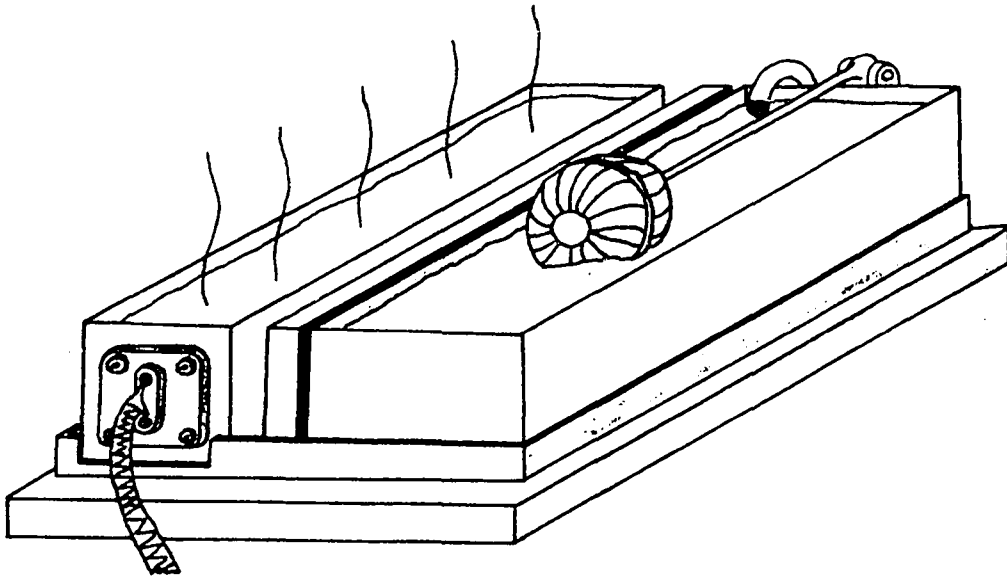

Figure 12. Steam generator

The water temperature in this larger tank was only a few degrees higher than the ambient air temperature and allowed a plastic float to be used on the toilet valve.

Steam and heat coming off the steam generator continuously heated the chamber air. In order to maintain the temperature at  $85 \pm 2$  degrees Fahrenheit, the refrigerating unit of the walk-in cooler was controlled by a thermostat. Air mixing and circulation was provided by a 14-inch fan running continuously. The fan, mounted behind the cooling coils, improved temperature control by increasing air flow across the cooling coils.

## PROCEDURE

This research was conducted in eight sections as shown in Table 3. Two different types of seed (Hawkeye soybeans and Pioneer 3306 seed corn) were used. Each of these had two different pretreatments applied to them, air dried or soaked for six hours in tap water at  $85 \pm 2$  degrees Fahrenheit. Each of these pretreated batches was further subdivided into two lots. One lot was treated in static (direct current) electric fields while the other lot was treated in 60-cycle-per-second electric fields. Thus, there were eight basic types of treatments as shown in Table 3. All control samples received the appropriate pretreatment.

Table 3. Summary of the types of treatments used

Seed type	Pretreatment	Type of field
Corn (Pioneer 3306, medium round)	Air dry	A.C.
Corn (Pioneer 3306, medium round)	Air dry	D.C.
Corn (Pioneer 3306, medium round)	Soaked 6 hours	A.C.
Corn (Pioneer 3306, medium round) <sup>a</sup>	Soaked 6 hours	D.C.
Soybeans (Hawkeye)	Air dry	A.C.
Soybeans (Hawkeye)	Air dry	D.C.
Soybeans (Hawkeye)	Soaked 6 hours)	A.C.
Soybeans (Hawkeye)	Soaked 6 hours)	D.C.

<sup>a</sup>In this set, there are two tests in which Pioneer 3306 medium flat seed corn was used.

Burch and Delouche (7) found that soybeans required a seed moisture content of 50 percent (wet basis) for germination. Eyster (29) found that oversoaking caused a decrease in seed viability. This he attributed to loss by the seeds of proteins, digestive enzymes, and growth promoting substances. Figure 13 shows that the moisture content of soybeans after soaking for six hours in tap water at  $85 \pm 2$  degrees Fahrenheit was 55 percent. Based upon these facts, a six hour soaking time was selected for soybeans.

Figure 13 shows that the moisture content of corn after soaking for six hours in tap water at  $85 \pm 2$  degrees Fahrenheit was about 29 percent. However, longer periods of soaking caused discoloration of the kernels which was probably due to lack of oxygen. This discoloration could change the germination ability of the seed. Corn does not need as high a moisture content to germinate as do soybeans. These facts were used as the basis for selecting the six hour soaking time for corn.

The smallest sized seed lots shown in Table 3 were broken down into lots of 125 seeds. Each of these lots was treated with a different electric field intensity or exposure time. When a static electric field was used, the voltage across the 1-1/2-inches separating the plates of the treating chamber was 500, 1000, 2000, 3000 or 3500 volts. In preliminary tests static plate voltages of 125, 210, 300, and 430 volts were used. Where possible these data were incorporated in the analysis and are shown in Appendix A. When 60-cycle current was used, this voltage was 500, 1000, 1500, 2000, 2500, 3000, 3500, 4000, 4500, 5000 or 5500 volts. The exposure times used for both types of fields were 1, 5, 10,

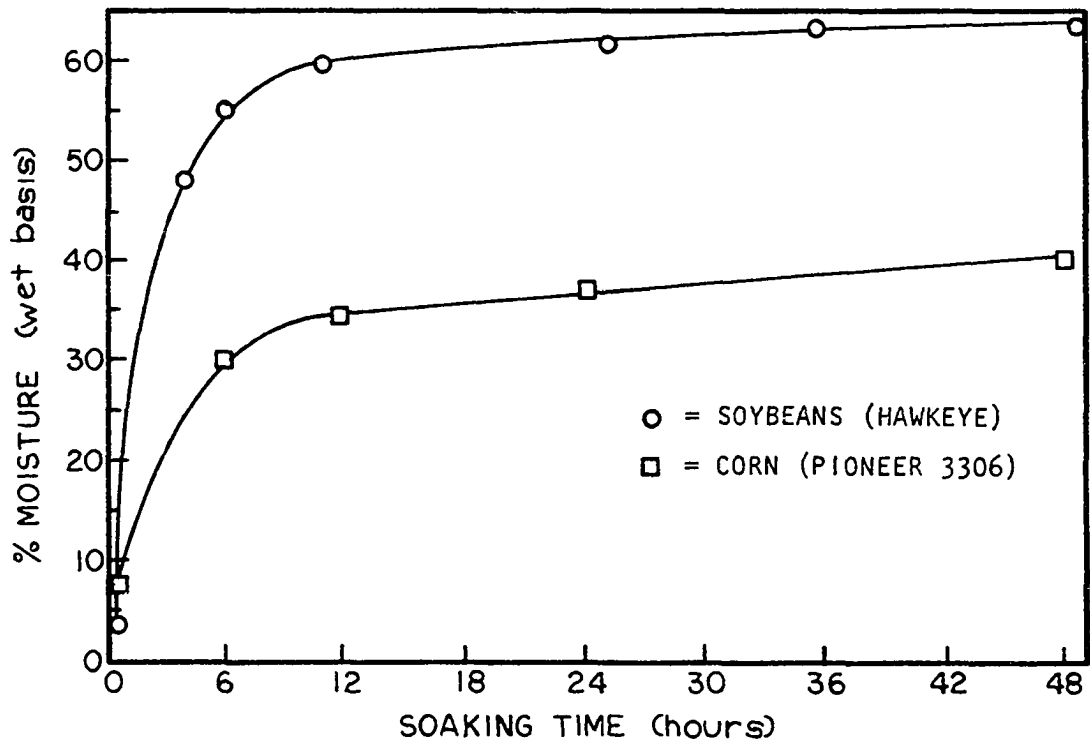

Figure 13. Moisture absorption curves at 85 degrees Fahrenheit for corn and soybean seeds immersed in tap water

15 and 20 seconds.

The seed was taken from the storage container (a 10-gallon metal garbage can) and placed directly in the hopper of the appropriate metering device. Air dry soybeans were metered by the plate type metering machine shown in Figure 4. Air dry corn and corn and soybeans soaked for six hours in tap water were metered by the belt type metering machine shown in Figure 8. Both metering machines metered the seeds directly onto the conveyor belt of the treating machine which carried the seeds through the electric field at the desired speed.

As the seeds came off the treating machine conveyor, visibly damaged and abnormal seeds were discarded. The remaining seeds were separated



into lots of 25 each and placed in 4-inch-diameter plastic petri dishes. Within two hours after treatment, the seeds were removed from the petri dishes and placed in the germinating chamber. Here they were placed on saturated filter paper (E and D type 615 or E and D type 613) which rested on top of 1/4-inch outdoor plywood. The chamber temperature was maintained at  $85 \pm 2$  degrees Fahrenheit while the humidity was held at  $95 \pm 3$  percent. The chamber was kept dark except when data were being taken. A 40-watt incandescent bulb provided illumination for observing the germinated seeds. Several preliminary tests were run to determine if this incandescent light influenced the results. No effects due to the light were found.

There were five lots of 25 seeds for each treatment arranged in a line within the chamber. The number of seeds which had germinated in each of these lots was recorded at frequent enough intervals to allow a graph to be plotted of time versus number of seeds germinated. Data were taken on an average of every four hours, but the exact time varied, depending on the rate of germination. Germination was considered to have occurred when the radicle pierced the seed coat.

## METHODS OF DATA ANALYSIS

Each time an observation was made on the germinating seeds six values were recorded for each treatment. The first value was the length of time the seeds had been in the germinating chamber. The other five values were the number of seeds which had germinated in each of the five lots of 25 seeds since the last observation. The number of seeds which germinated in an interval of time in the five lots was added together for the statistical analysis. This value, the observation value, gave the number of seeds which germinated in the five lots in a time interval. The values shown in Appendix A as "the number of seeds germinated" are cumulative values, and were calculated by adding up all the observation values for the intervals from zero time to the observation time which is shown in the far left column in Appendix A.

Figures 14 through 21 show some sample plots of this cumulative data vs. time. In this form it was difficult to compare the effects of the various treatments. To facilitate these comparisons the axis of the graphs shown in Figures 14 through 21 were transformed such that the data would approximate a straight line when plotted on the transformed graph. The shape of the curves in Figures 14 through 21 suggested that the data might have a normal distribution. To test the normal hypothesis, a PROBIT transformation was applied to the ordinate of these graphs. This transformation assumed that the data were normally distributed and solved the standardized normal equation, Equation 7, for  $X_i$  when  $P(X)$  and  $y$  were fed in as known values.

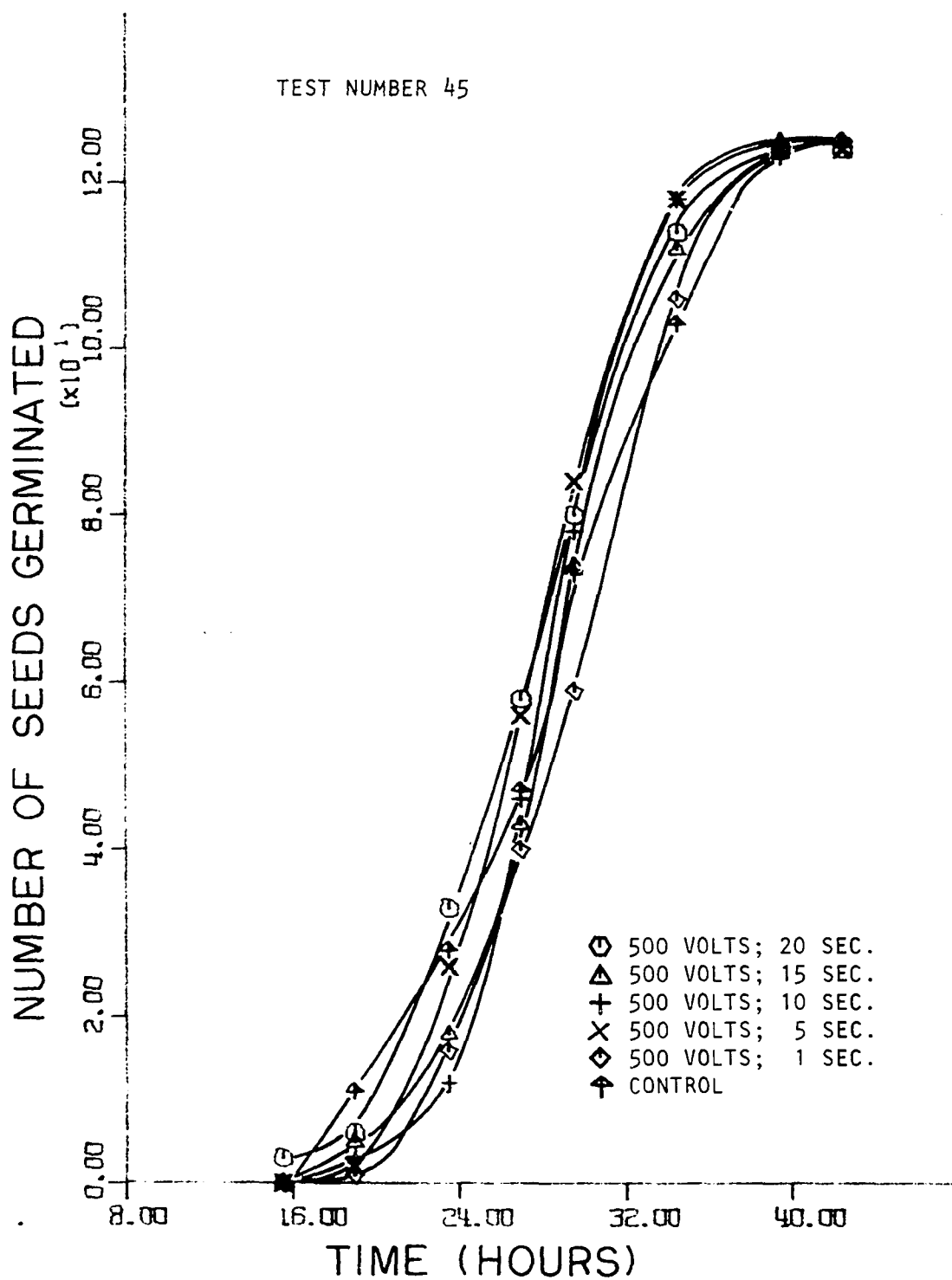

Figure 14. Germination rate of unsoaked soybeans after treatment in a static electric field

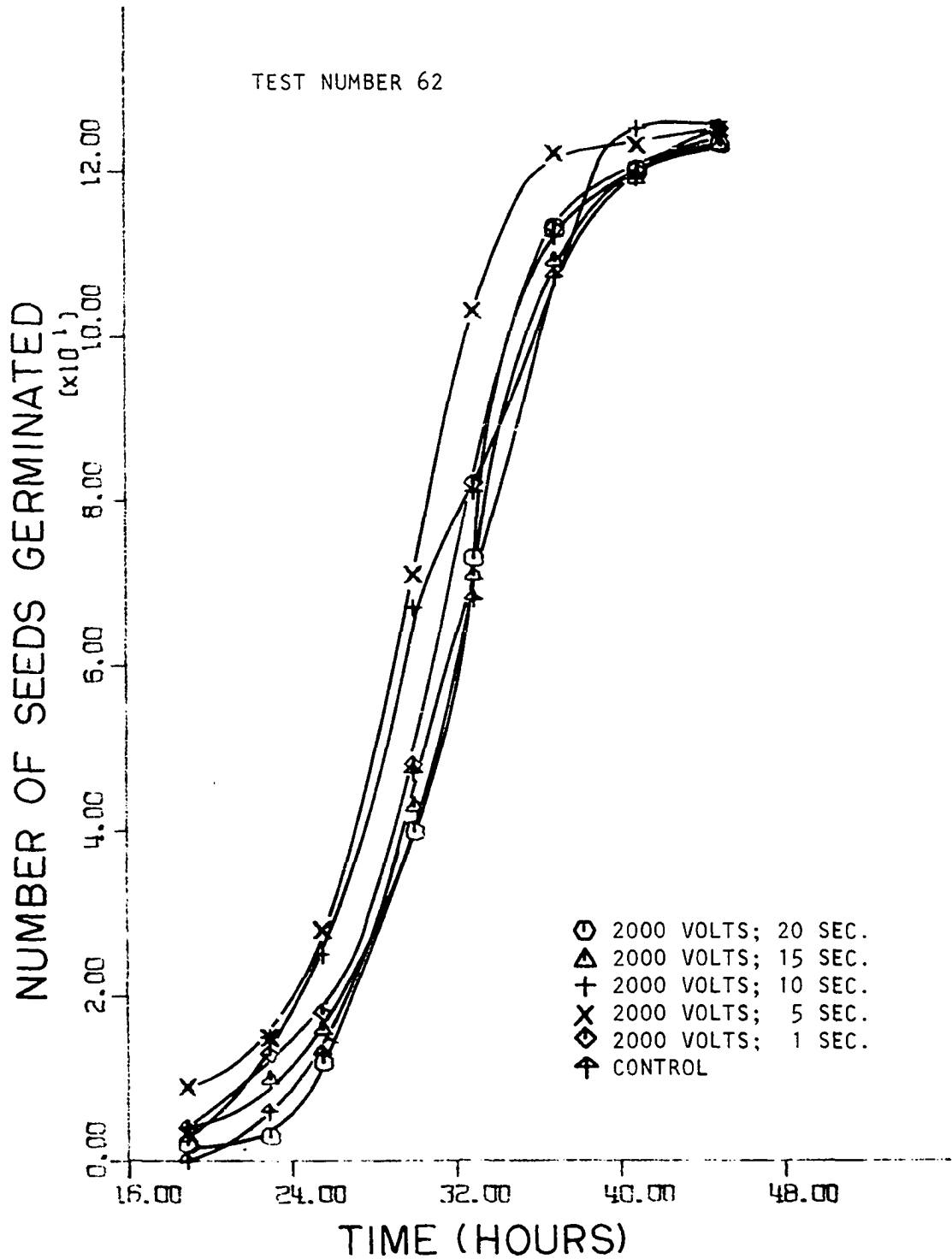

Figure 15. Germination rate of unsoaked soybeans after treatment in a 60 hertz electric field

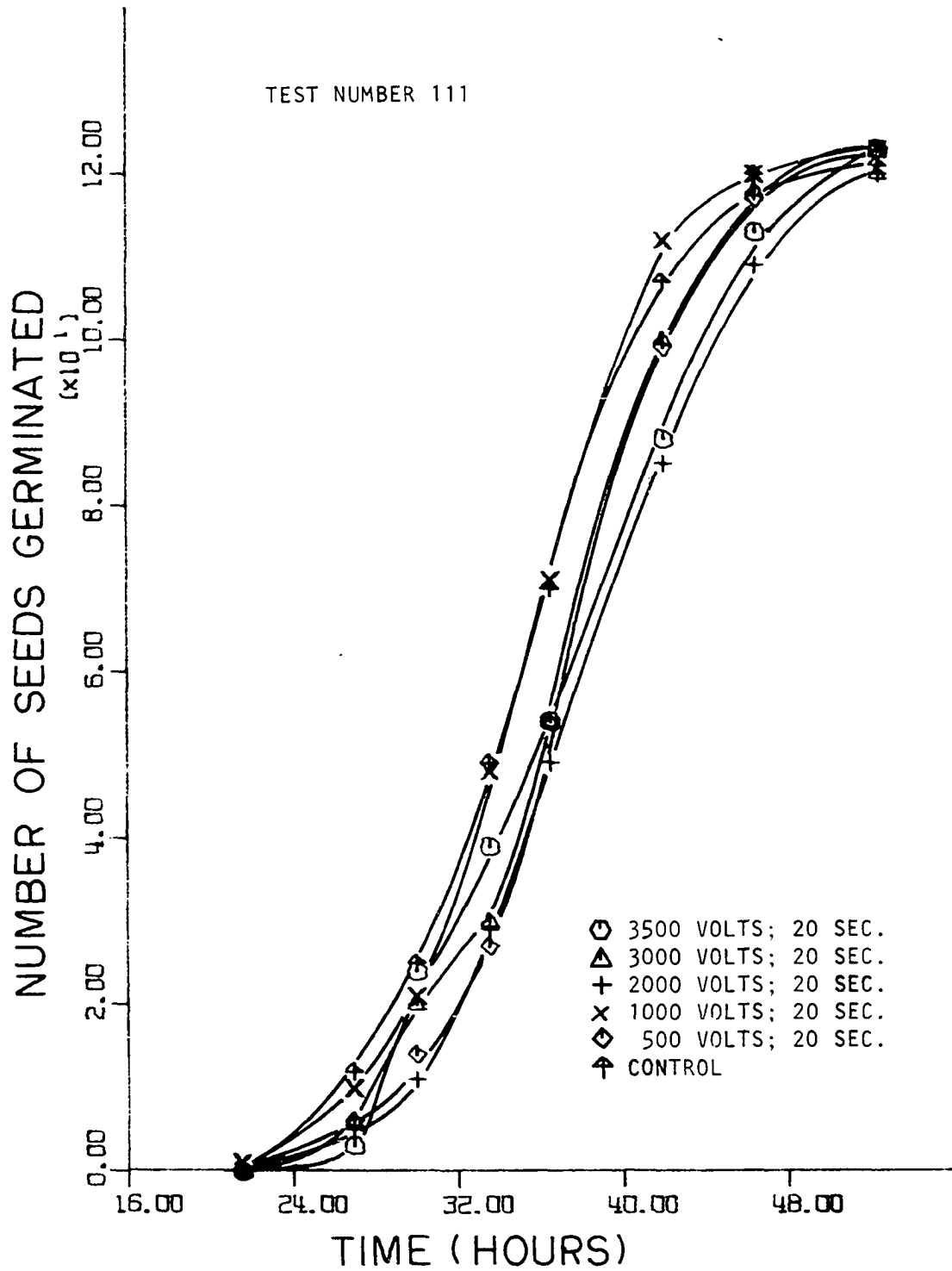

Figure 16. Germination rate of unsoaked corn after treatment in a static electric field

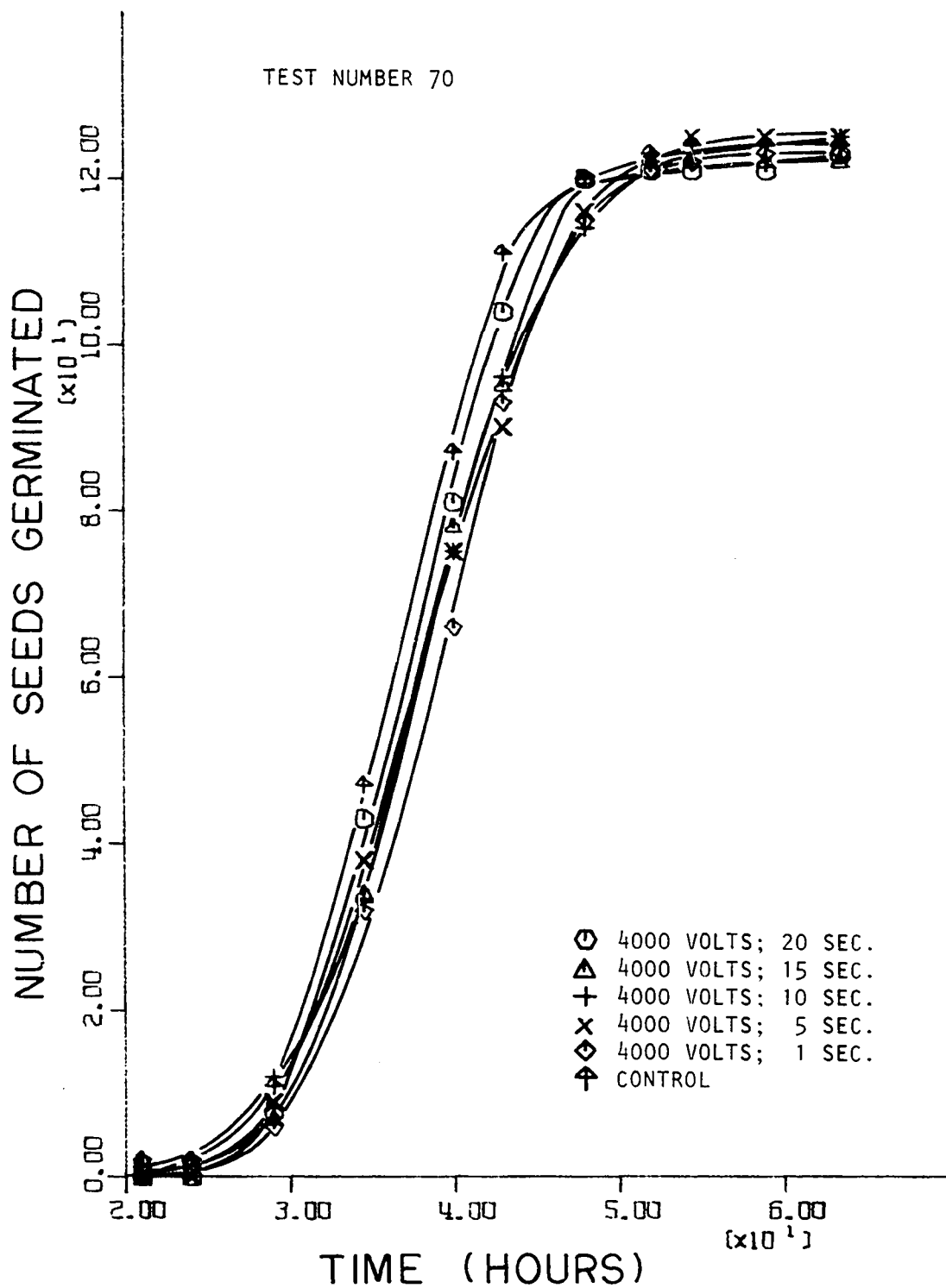

Figure 17. Germination rate of unsoaked corn after treatment in a 60 hertz electric field

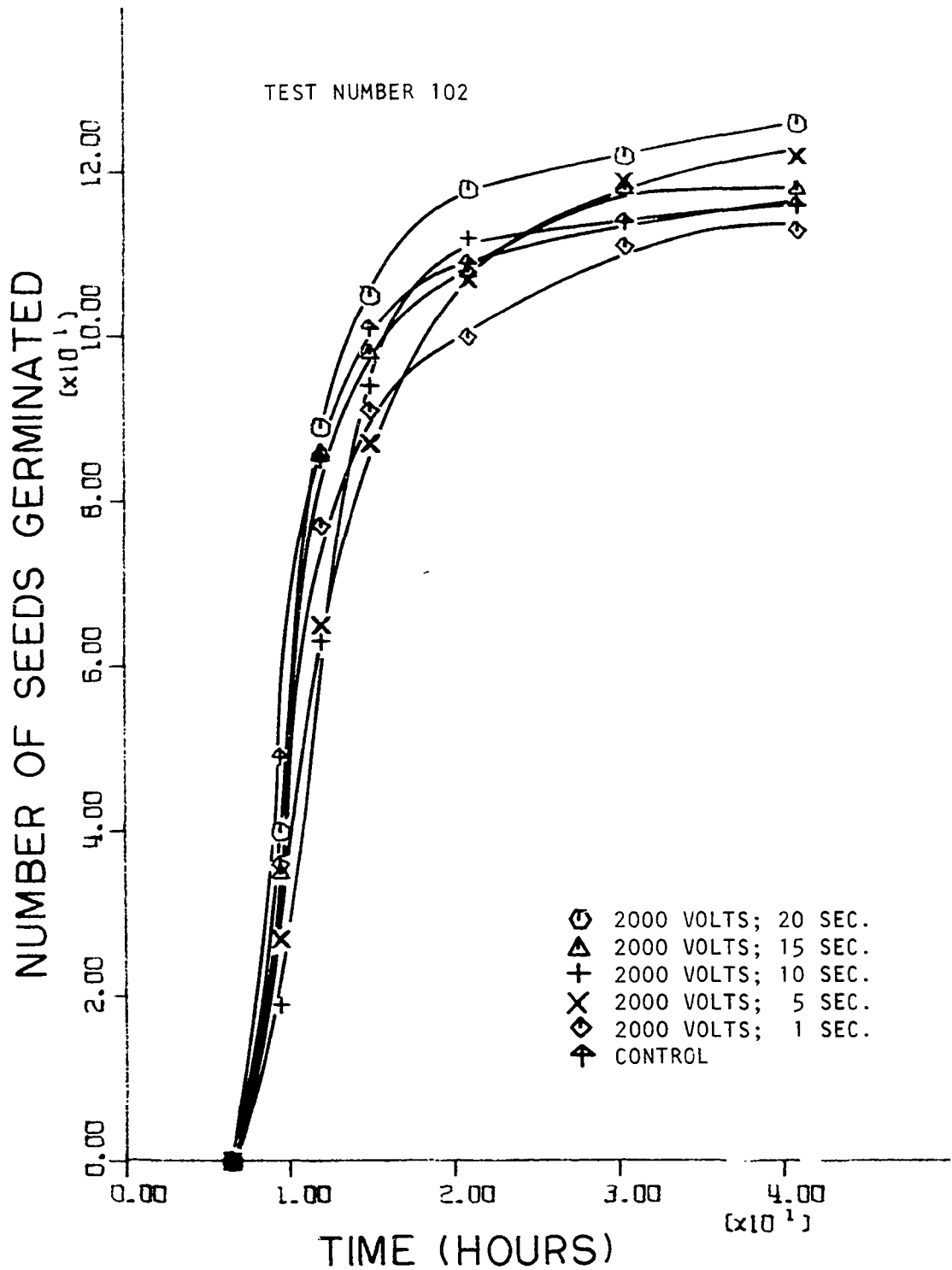

Figure 18. Germination rate of soaked soybeans after treatment in a static electric field

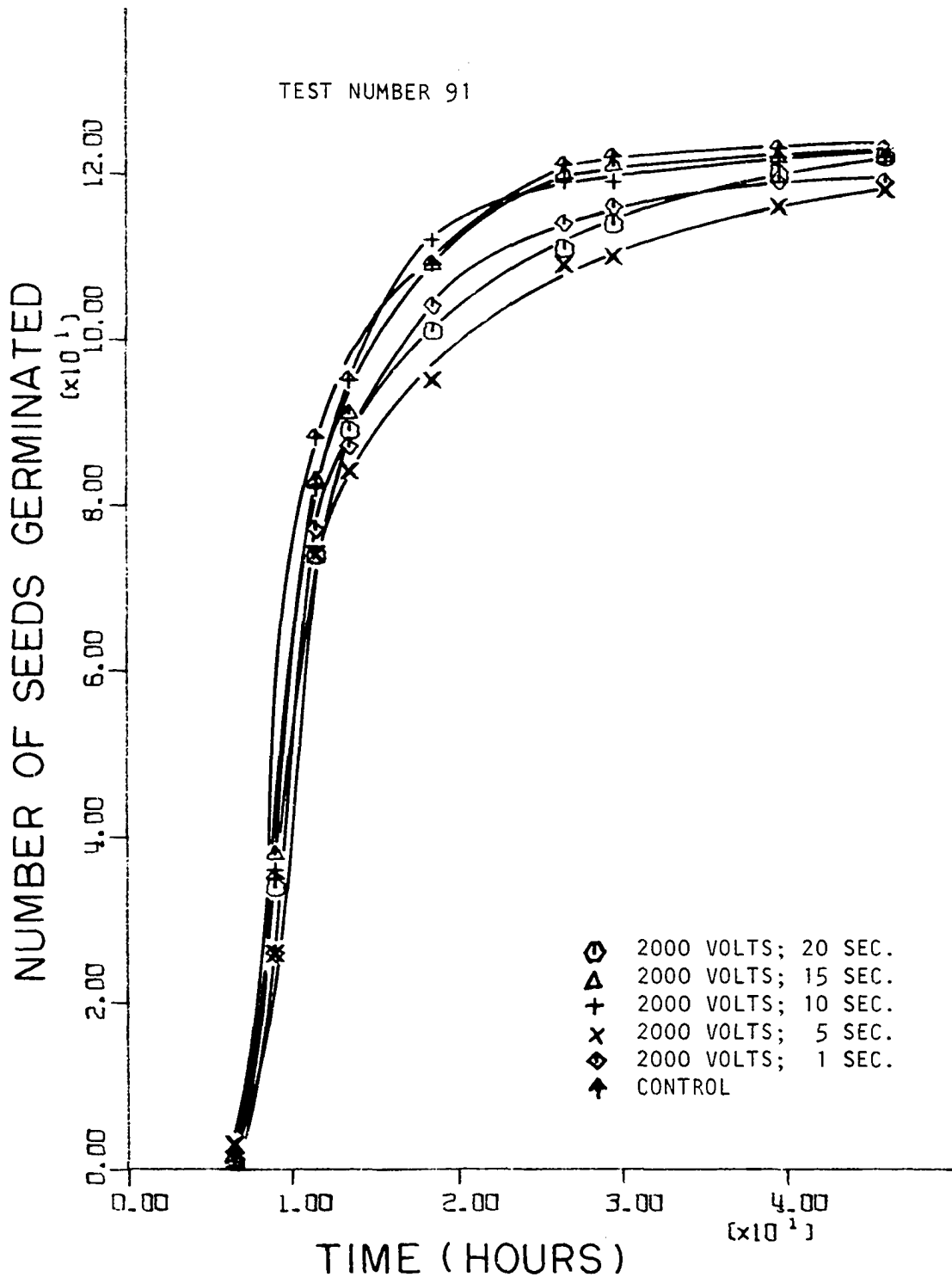

Figure 19. Germination rate of soaked soybeans after treatment in a 60 hertz electric field



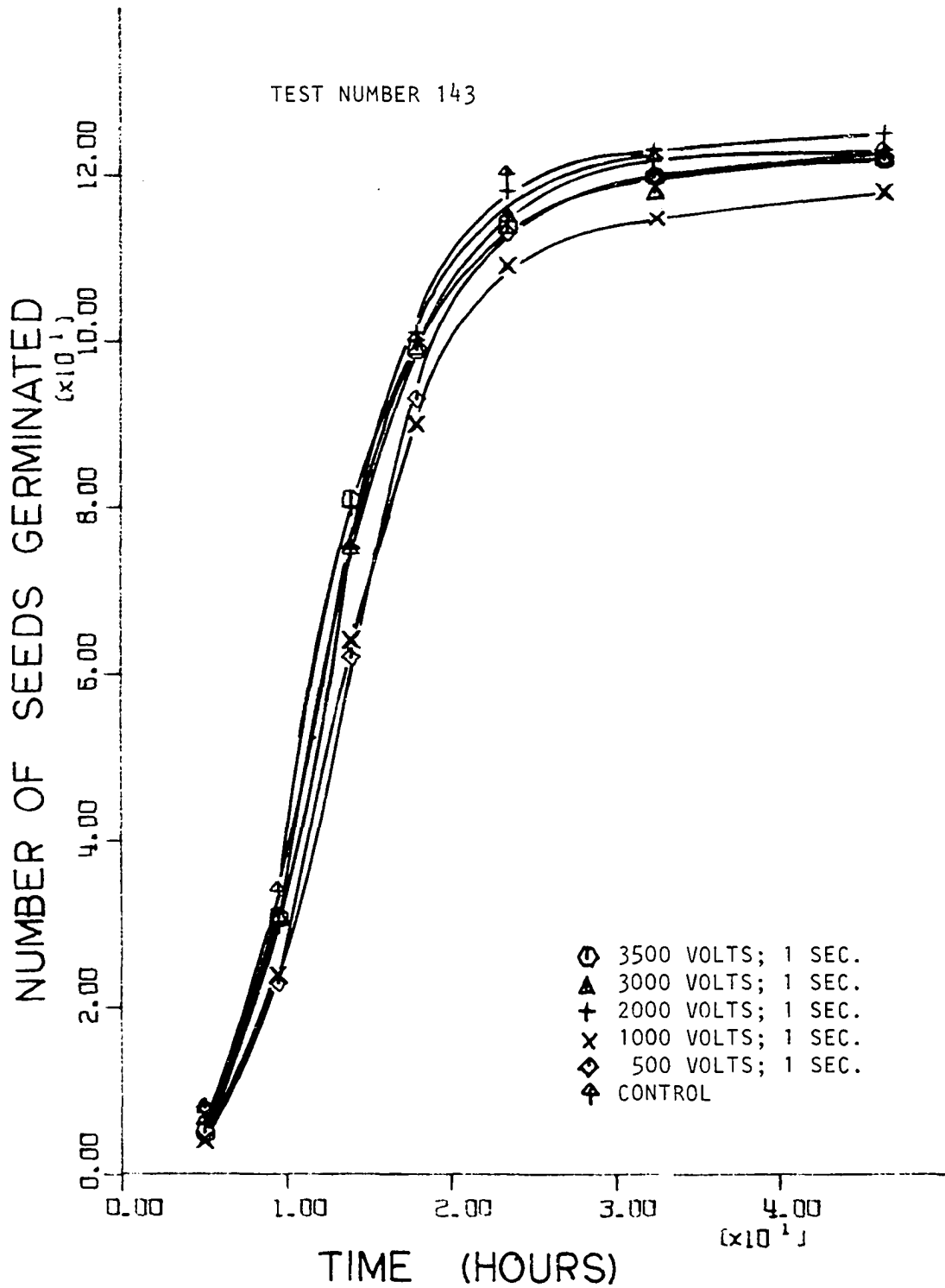

Figure 20. Germination rate of soaked corn after treatment in a static electric field

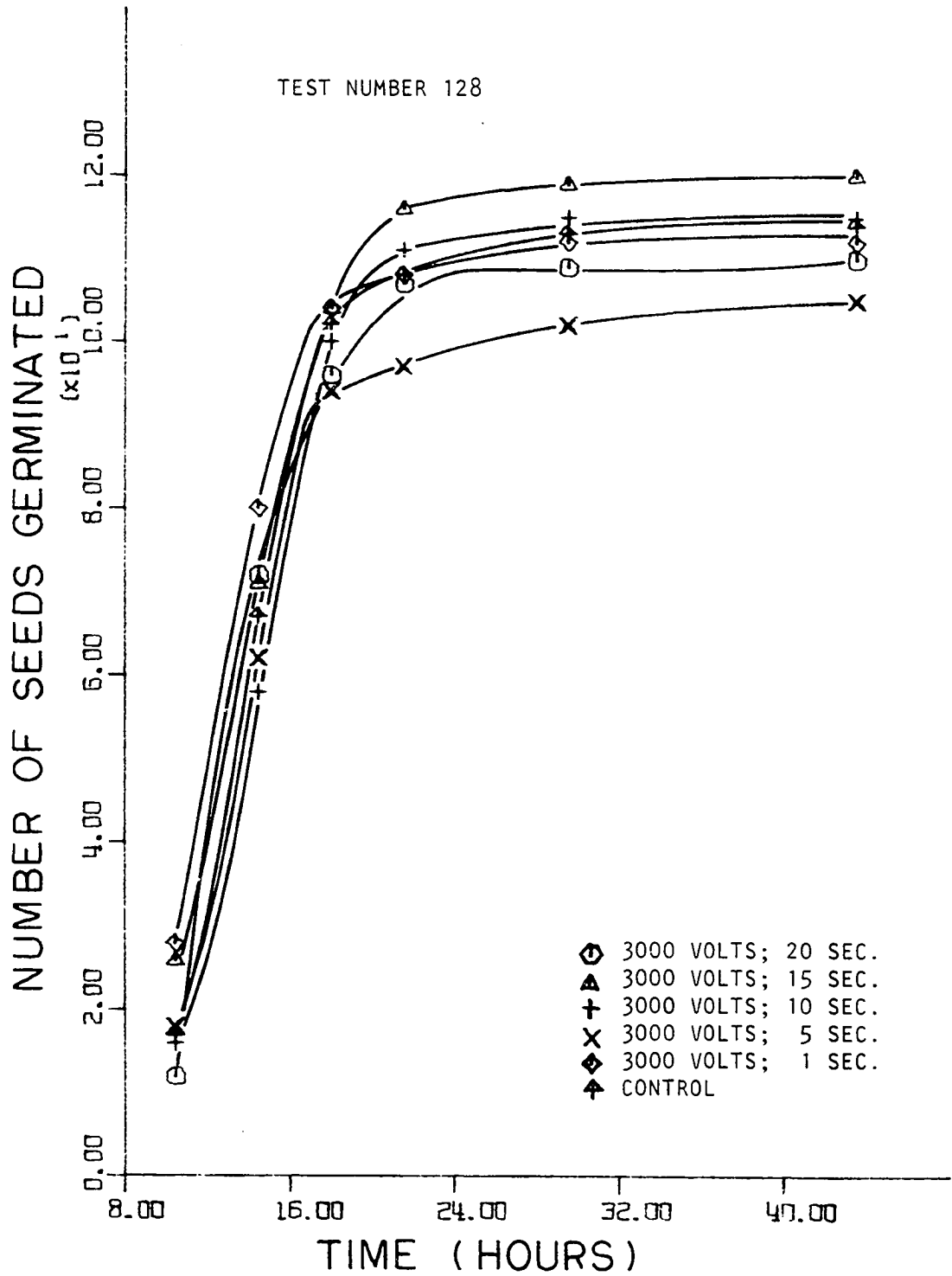

Figure 21. Germination rate of soaked corn after treatment in a 60 hertz electric field

$$P(X_i) = \int_{-\infty}^{X_i} \frac{1}{\sqrt{2\pi}} \exp(-1/2 y^2) dy \quad (7)$$

where:

$P(X_i)$  = probability that  $x$  is less than or equal to  $X_i$

$X_i$  = normal deviate

$y$  = variable of integration (time in this case)

When working with dry corn and soybean seeds, a plot of  $X_i$  versus time was found to produce a linear relationship, and indicated that these data were normally distributed. Data from tests with corn and soybeans which had been soaked six hours in tap water before treatment produced a nonlinear relationship on a  $X_i$  versus time plot. This indicated that these data were not normally distributed. However, with soaked corn it was found that a plot of  $X_i$  versus the natural logarithm of time would produce a nearly linear relationship. With soaked soybeans a nearly linear relationship resulted if  $X_i$  was plotted against the natural logarithm of the natural logarithm of time, i.e.,  $X_i$  versus  $\log(\log t)$ .

Since there were a large number of points which had to be plotted to produce these graphs, a computer program to transform the data and plot the graphs was written for the IBM 360-65 computer. This program in the form used to plot the PROBIT vs.  $\log(\log t)$  for soaked soybeans is shown in Appendix B. Removal of a few statements from this program allowed figures of  $X_i$  versus  $\log t$  and  $X_i$  versus  $t$  to be plotted.

Figures 22-29 show examples of these plots. Figures 22 and 23 are for dry soybeans, Figures 24 and 25 for dry corn, Figures 26 and 27 for soaked soybeans, and Figures 28 and 29 for soaked corn. Since these

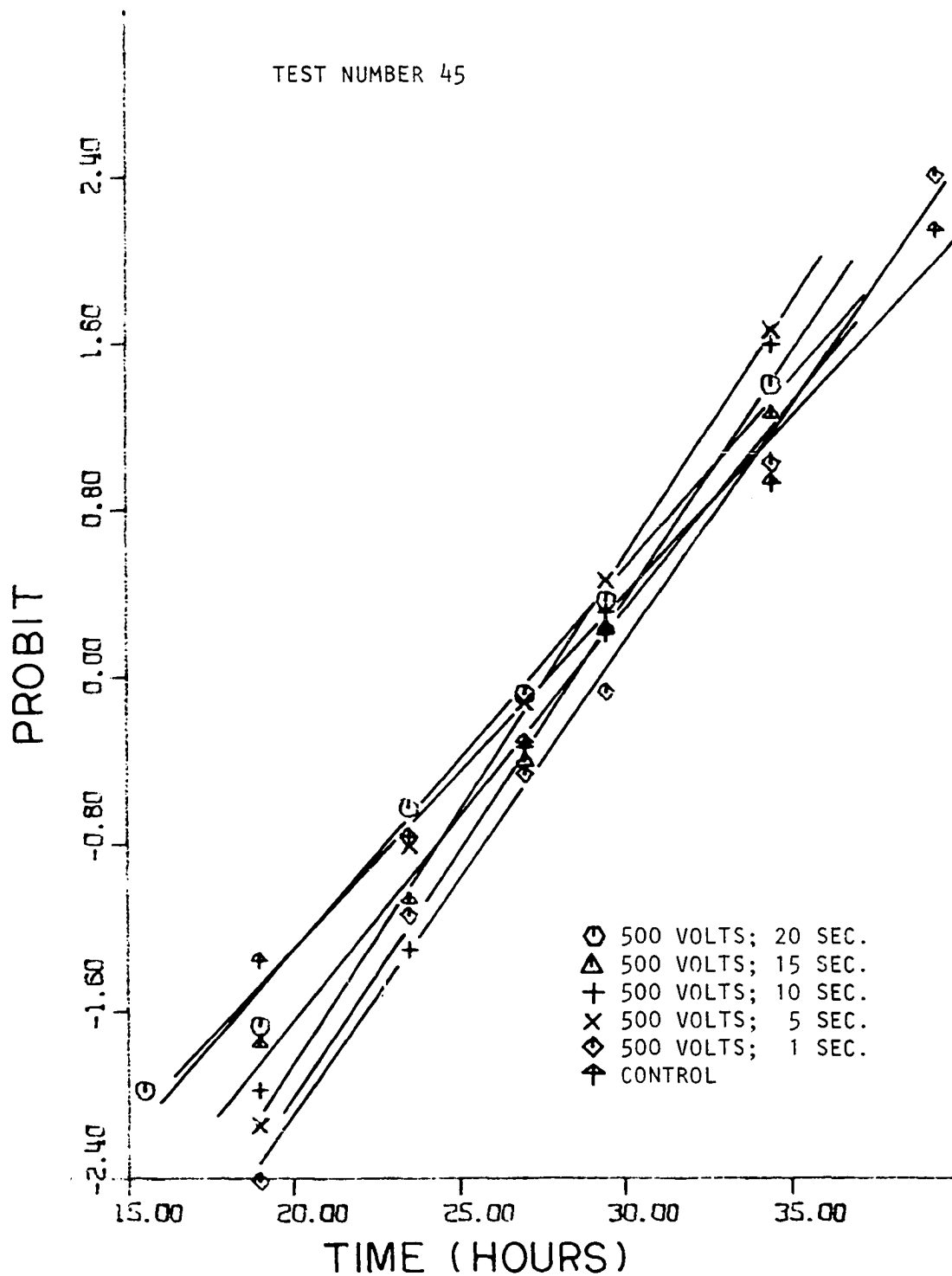

Figure 22. Transformed plot of the germination rate of unsoaked soybeans after treatment in a static electric field

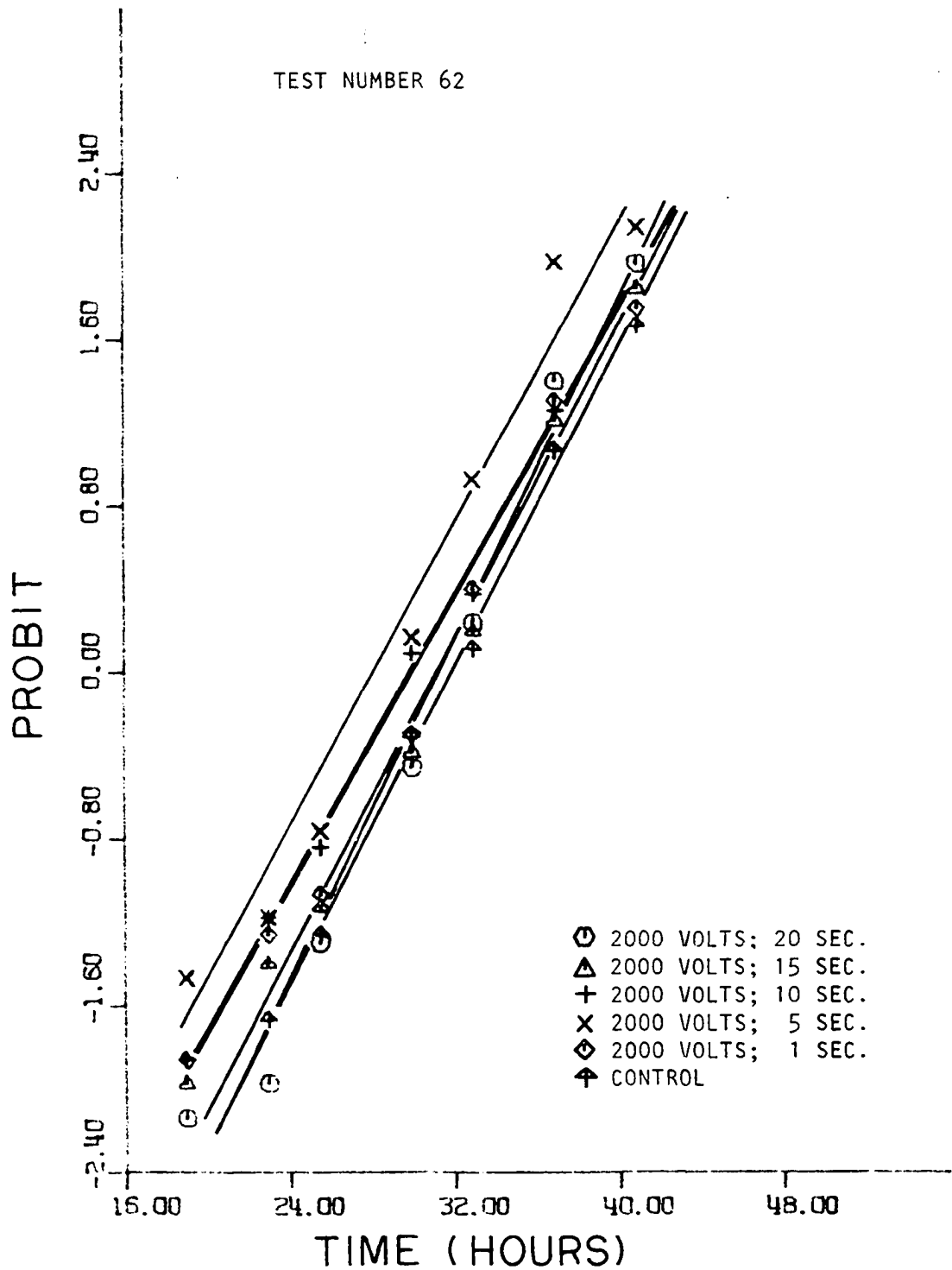

Figure 23. Transformed plot of the germination rate of unsoaked soybeans after treatment in a 60 hertz electric field

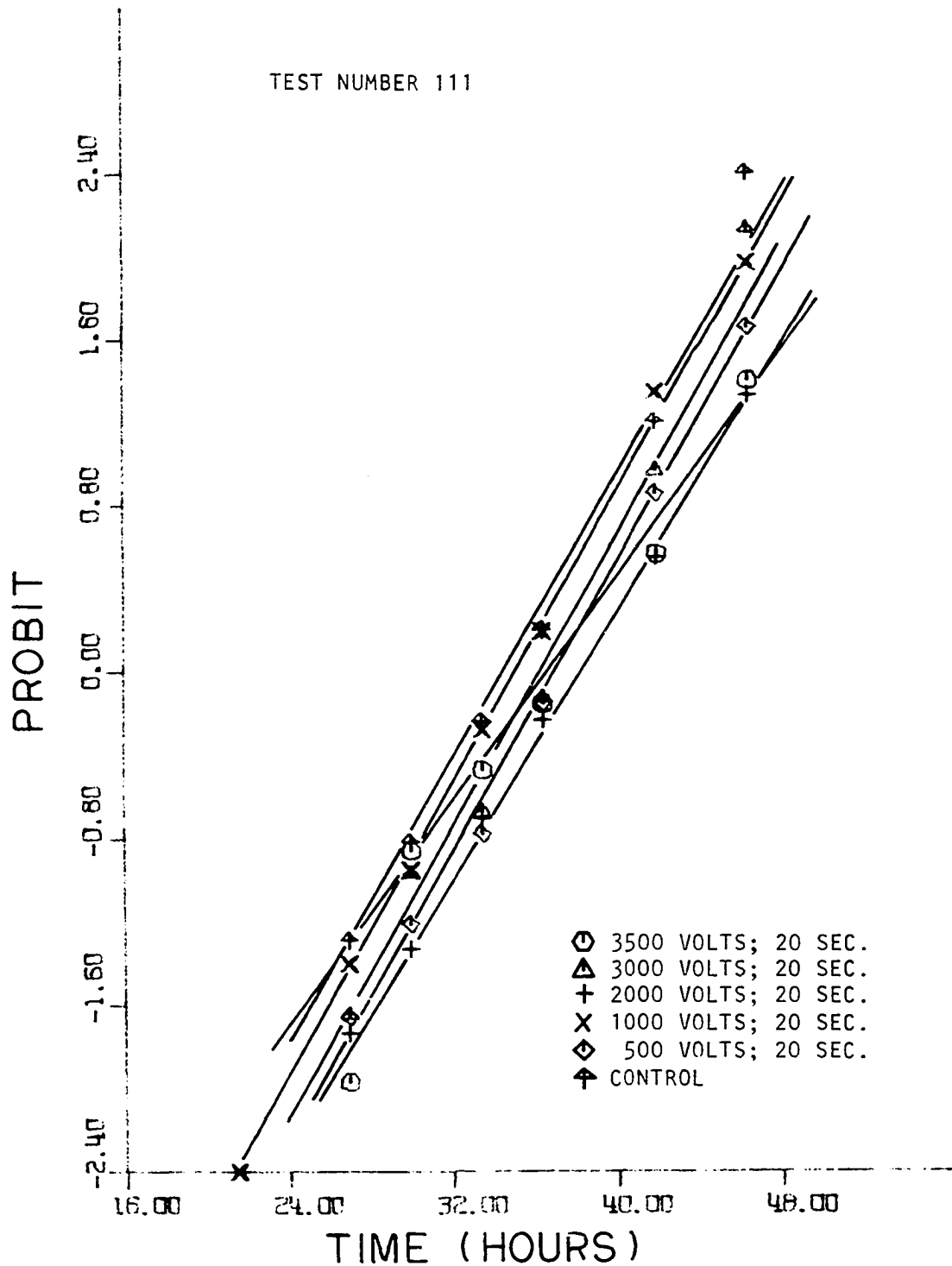

Figure 24. Transformed plot of the germination rate of unsoaked corn after treatment in a static electric field

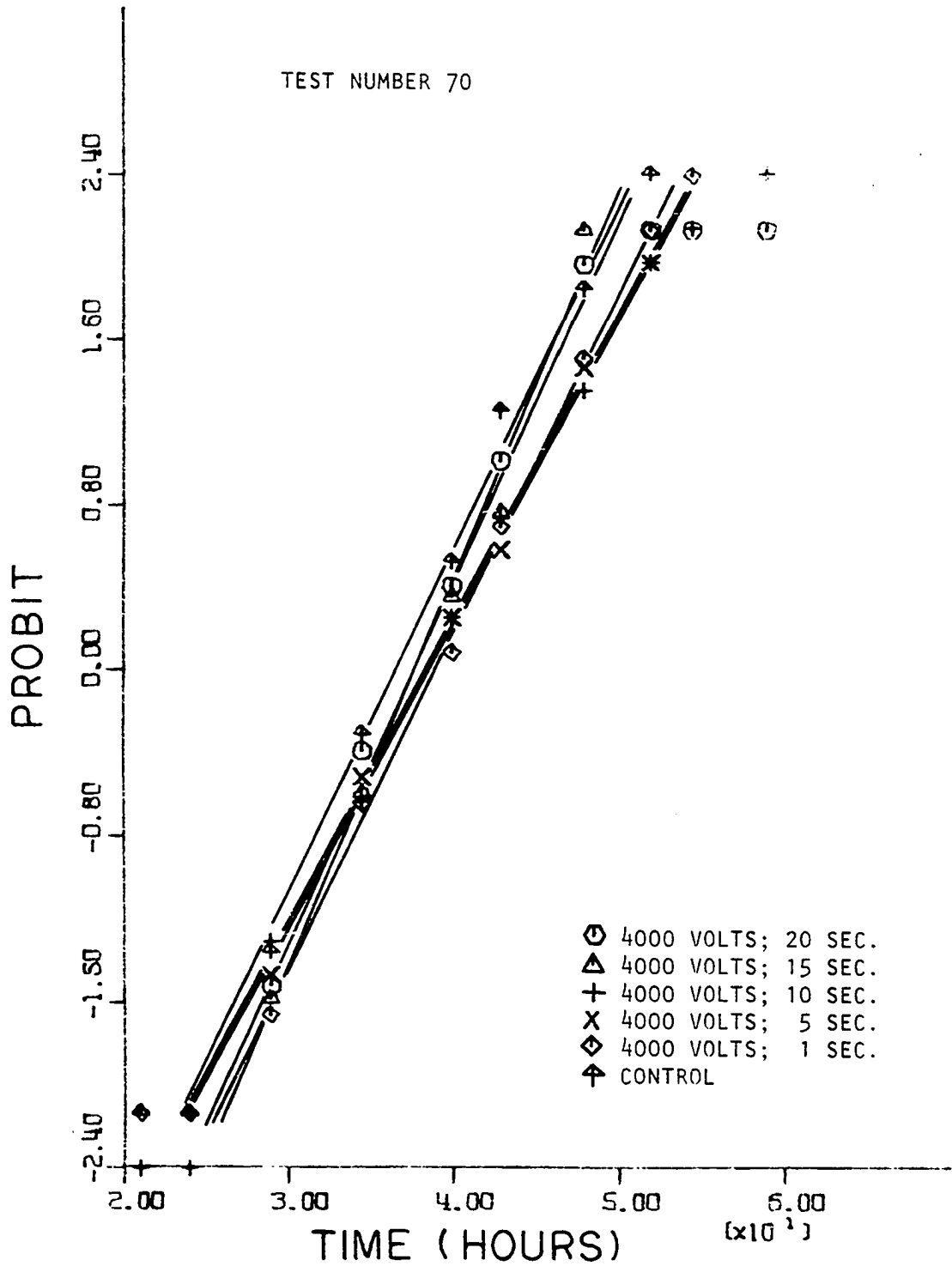

Figure 25. Transformed plot of the germination rate of unsoaked corn after treatment in a 60 hertz electric field

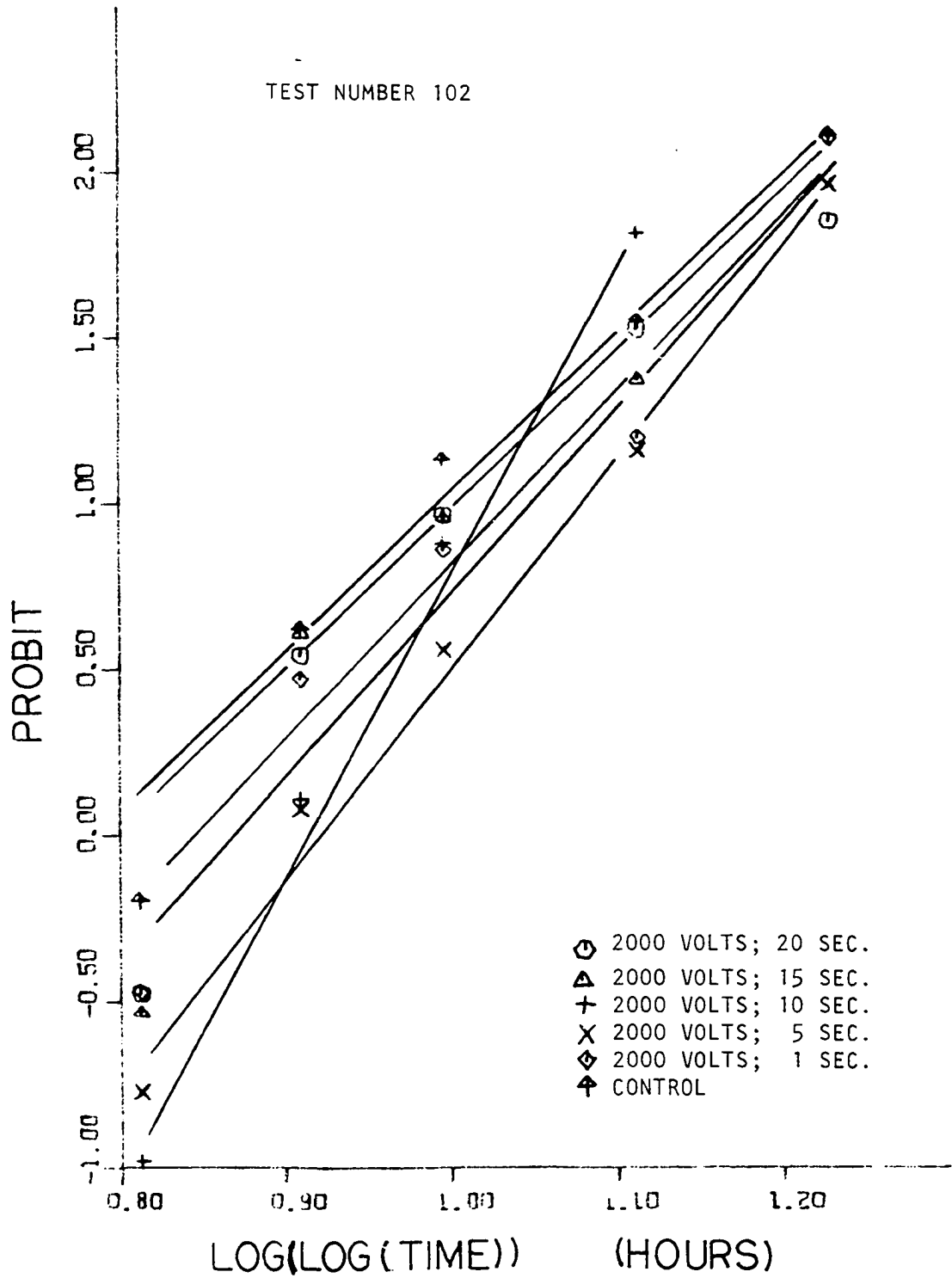

Figure 26. Transformed plot of the germination rate of soaked soybeans after treatment in a static electric field



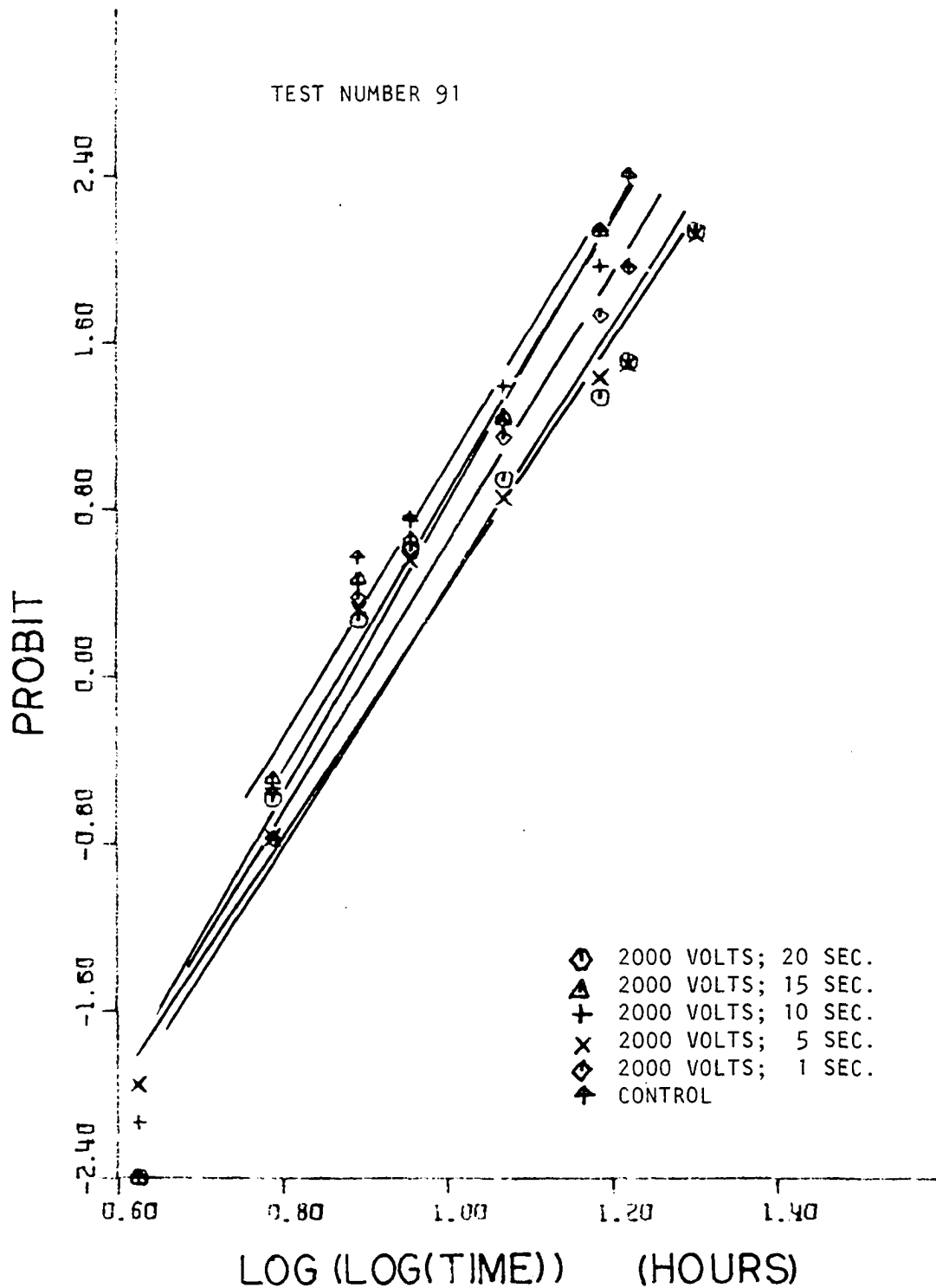

Figure 27. Transformed plot of the germination rate of soaked soybeans after treatment in a 60 hertz electric field

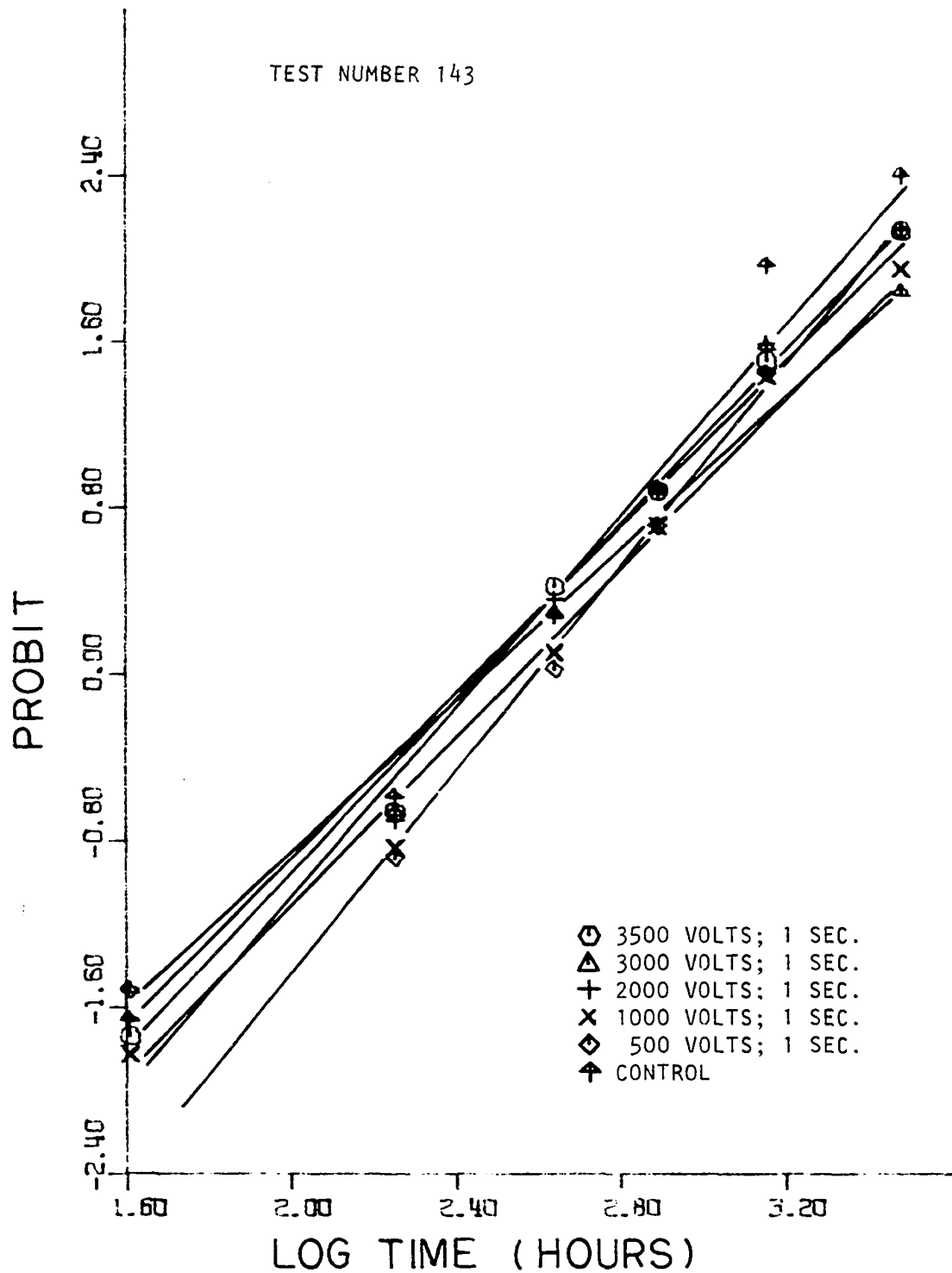

Figure 28. Transformed plot of the germination rate of soaked corn after treatment in a static electric field

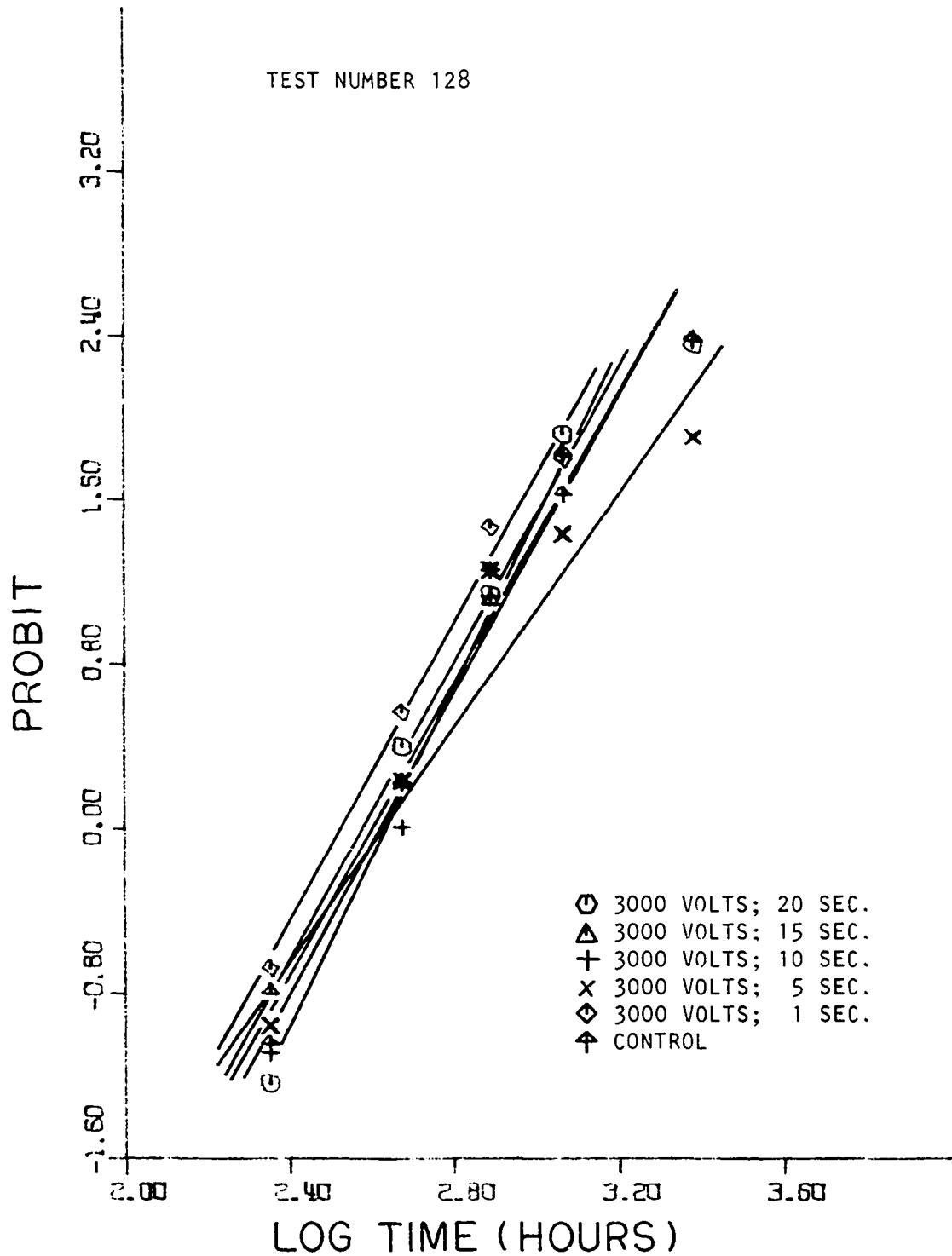

Figure 29. Transformed plot of the germination rate of soaked corn after treatment in a 60 hertz electric field

transformations produce a nearly straight line relationship between the transformed time and the PROBIT of the number of seeds germinated, it was concluded that the transformed data were very nearly normally distributed.

After the data had been transformed, comparisons were made between the various treatments. To make these comparisons it was necessary to calculate the mean time for 50 percent of the seeds to germinate and standard deviation of this time for each experiment. However, since each observation of the number of seeds germinated was dependent on all the previous observations made on the same experiment, two estimators had to be developed which would estimate the mean time for 50 percent of the seeds in an experiment to germinate and the standard deviation of this mean time.

Freund (32) stated that a good estimator should be unbiased, consistent, efficient, and sufficient. In brief, the expected value of an unbiased estimator equals the parameter it is supposed to estimate. A consistent estimator is unbiased and its variance approaches zero as the number of observations approaches infinity. The most efficient estimator has the smallest variance of any estimator while a sufficient estimator uses all the available information in the sample in making the estimate. Freund (32) also stated that an estimator developed by the method of maximum likelihood will be a sufficient estimator whenever a sufficient estimator exists and for a large number of observations it will be the most efficient estimator.

Chamberlain<sup>1</sup> gave the likelihood function for the nonindependent normally distributed data developed in these experiments as:

$$L(\bar{t}, \sigma) = \frac{N}{m_1! m_2! \cdots m_k!} [F(t_1) - F(t_0)]^{m_1} \\ [F(t_2) - F(t_1)]^{m_2} \cdots [F(t_k) - F(t_{k-1})]^{m_k} \quad (8)$$

where:

$$F(t_i) = \int_{-\infty}^{t_i} \frac{1}{\sqrt{2\pi} \sigma} \exp \left[ -\frac{1}{2} \left( \frac{t_i - \bar{t}}{\sigma} \right)^2 \right] dt \quad (9)$$

$\bar{t}$  = mean time for 50 percent of the seeds to germinate

$\sigma$  = standard deviation for this time

$m_i$  = number of seeds germinating in the time interval between  $t_{i-1}$  and  $t_i$

$N$  = number of seeds which germinated in the test

Normally the logarithm of Equation 8 is differentiated with respect to  $\bar{t}$  and  $\sigma$  and each of these resulting equations set equal to zero. This provides two equations in two unknowns which can be solved for the estimates of  $\bar{t}$  and  $\sigma$ . However, differentiation of the logarithm of Equation 8 with respect to  $\bar{t}$  and  $\sigma$  leaves an integral similar to Equation 9 in the denominator which contains  $\bar{t}$  and  $\sigma$ . Thus, an explicit solution is not possible.

---

<sup>1</sup>Richard Chamberlain, Graduate Assistant, Department of Statistics, Iowa State University, Ames, Iowa. Statistical formula describing the likelihood function for nonindependent normally distributed observations. Private communication. 1968.

The purpose of the method of maximum likelihood is to maximize Equation 8 or the logarithm of Equation 8. Usually the logarithm of the likelihood function is maximized since it usually is simpler. The logarithm of Equation 8 is given by:

$$\begin{aligned} \log [L(\bar{t}, \sigma)] = & \log C + m_1 \log [F(t_1) - F(t_0)] + \\ & m_2 \log [F(t_2) - F(t_1)] + \dots + \dots + \\ & m_k \log [F(t_k) - F(t_{k-1})] \end{aligned} \quad (10)$$

$$\text{where: } C = \frac{N}{m_1! m_2! \dots m_k!}$$

Thus, if Equation 10 could be evaluated for many values of  $\bar{t}$  and  $\sigma$ , the value of  $\bar{t}$  and  $\sigma$  which maximize  $\log [L(\bar{t}, \sigma)]$  could be found. This was the procedure used to find the values of  $\bar{t}$  and  $\sigma$  for each experiment.

Because the number of calculations involved in maximizing Equation 10 was large, a program was developed for the IBM 360-65 computer to determine this value for each experiment. This program is shown in Appendix B. In this program an initial estimate of  $\bar{t}$  and  $\sigma$  are calculated from the data by the following formulas:

$$\bar{t} = \frac{\sum_{i=1}^k t_i m_i}{\sum_{i=1}^k m_i} \quad (11)$$

$$\sigma = \sqrt{\frac{\sum_{i=1}^k (t_i - \bar{t})^2 m_i}{\sum_{i=1}^k m_i}} \quad (12)$$

where:

$k$  = number of time intervals

$m_i$  = number of seeds which germinated between time  $t_{i-1}$  and  $t_i$

$t_i$  = time of  $i$ th observation after the seeds were placed in the germinating chamber

These values were used to solve Equation 10. Equation 10 was then evaluated at eight other points around the first one by adding or subtracting a small amount to either or both  $\bar{t}$  and  $\sigma$ . For example, the first evaluation of Equation 10 was done with  $\bar{t} = \bar{t}$  and  $\sigma = \sigma$ . The next evaluations were done when  $\bar{t}$  and  $\sigma$  had the following values:  $\bar{t} + 0.1$ ,  $\sigma - 0.1$ ;  $\bar{t} + 0.1$ ,  $\sigma$ ;  $\bar{t} + 0.1$ ,  $\sigma + 0.1$ ;  $\bar{t}$ ,  $\sigma - 0.1$ ;  $\bar{t}$ ,  $\sigma + 0.1$ ;  $\bar{t} - 0.1$ ,  $\sigma - 0.1$ ;  $\bar{t} - 0.1$ ,  $\sigma$ ;  $\bar{t} - 0.1$ ,  $\sigma + 0.1$ . These nine values for  $\log [L(\bar{t}, \sigma)]$  were then censored and the largest one was chosen as the starting point for the next iteration. The iterations were continued in a similar manner until the center point was the largest value. The values of  $\bar{t}$  and  $\sigma$  used to calculate this value of Equation 10 were then the mean and standard deviation of the data from that experiment.

It was found by plotting the raw data and the fitted line computed from the calculated values of  $\bar{t}$  and  $\sigma$  that an increment of 0.1 was sufficiently accurate for the data from dry soybeans and corn. However, when logarithms were used as in the case of soybeans and corn which had been soaked in water six hours before treatment, an increment of 0.01 had to be used.

The surface which is described by Equation 10, on which points were evaluated during calculation of  $\bar{t}$  and  $\sigma$ , is a well behaved surface, i.e.,

it has only one maximum. If there were more than one maximum the type of iterative procedure used to evaluate  $\bar{t}$  and  $\sigma$  would not be very useful since there would be no way of determining which maximum the procedure had found. Thus, the means,  $\bar{t}$ , and standard deviation,  $\sigma$ , shown in Appendix A are the correct ones for the data. The  $\sigma$  values shown for the soaked corn were calculated using the logarithm of time, while the values of the means are real time values. The  $\sigma$  values shown for soaked soybeans were calculated using the log [log (time)], but these means are real time values.

The final step, comparing the  $\bar{t}$  and  $\sigma$  values, was done by regression and analysis of variance techniques. Use was made of the t test and the F test for determining significance of the various calculated values.



## DISCUSSION OF RESULTS

To determine the effects of the various treatments, the data were divided into four groups and two regressions were run on each group. The grouping was done as follows: soybeans treated when air dry, corn treated when air dry, soybeans treated after soaking for six hours in tap water, and corn treated after soaking for six hours in tap water. One regression on each group used  $\sigma$  as the dependent variable while the second regression used  $\bar{t}$  as the dependent variable. These regressions together with a close study of the data indicated that the variation which existed from one test to the next, due to their being in the germination chamber at different times, was much larger than the effect due to the treatments.

To remove some of this variation one dummy variable was placed in the linear model for each of the experiments (i.e., each six tests) except one. This allowed each test to have a different intercept but required that all the regression lines for the data in one group have the same slope. Thus, the dummy variables accounted for the variation between experiments. This greatly reduced the size of the error term and allowed detection of much smaller differences due to the treatments.

When the same four groups of data as described above were analyzed with the dummy variables in the model, the  $X'X$  matrix closely approached singularity and so could not be inverted. This singularity was due to the fact that a linear combination of some of the dummy variables was proportional to the values appearing in the column representing the type of field used (i.e., static or 60 hertz field). This problem was eliminated by carrying out regressions with the models shown in Equations

13 through 16 and then recombining the sum of squares to get the values desired.

$$y = B_1X_1 + B_2X_2 + B_3X_3 + e \quad (13)$$

$$y = B_1X_1 + B_2X_2 + B_3X_3 + B_4X_4 + e \quad (14)$$

$$y = B_1X_1 + B_5X_5 + B_6X_6 + \text{-----} + B_{n-1}X_{n-1} + e \quad (15)$$

$$y = B_1X_1 + B_2X_2 + B_3X_3 + B_5X_5 + B_6X_6 + \text{-----} + B_{n-1}X_{n-1} + e \quad (16)$$

where:

$B_1, B_2, B_{n-1}$  = regression coefficients

$y$  = dependent variable and was representing either the mean time for 50 percent of the seeds to germinate or the standard deviation of this time

$X_1$  = mean

$X_2$  = exposure time in the electric field

$X_3$  = voltage across the 1-1/2 inches separating the treating plates

$X_4$  = type of field used (static or 60 hertz)

$X_5, X_6, \text{-----}, X_{n-1}$  = dummy variables

$n$  = the number of experiments (usually six tests per experiment) in the data group

$e$  = error term

The recombination of the sum of squares is best explained by following through an example. Table 4 gives the analysis of variance for the

Table 4. Regression analysis for data from experiments with air dry soybeans

Model no.	Variation due to	D.F.	Sum of squares	
			Standard deviation	Mean
1 (Equation 13)	Total	303	300.91	7956.45
	Regression	2	10.01	41.20
	Residual	301	290.90	7915.25
2 (Equation 14)	Total	303	300.91	7956.45
	Regression	3	62.05	1771.76
	Residual	300	238.86	6184.69
3 (Equation 15)	Total	303	300.91	7956.45
	Regression	50	236.03	7682.07
	Residual	253	64.88	274.38
4 (Equation 16)	Total	303	300.91	7956.45
	Regression	52	236.78	7682.25
	Residual	251	64.12	274.20

Table 5. Regression analysis for data from experiments with air dry corn

Model no.	Variation due to	D.F.	Sum of squares	
			Standard deviation	Mean
1 (Equation 13)	Total	131	46.97	609.91
	Regression	2	0.70	25.53
	Residual	129	46.26	584.38
2 (Equation 14)	Total	131	46.97	609.91
	Regression	3	5.77	131.85
	Residual	128	41.19	478.06
3 (Equation 15)	Total	131	46.97	609.91
	Regression	21	25.23	527.78
	Residual	110	21.74	82.13
4 (Equation 16)	Total	131	46.97	609.91
	Regression	23	26.35	538.47
	Residual	108	20.62	71.44

Table 6. Regression analysis for data from experiments with soaked soybeans

Model no.	Variation due to	D.F.	Sum of squares	
			Standard deviation	Mean
1 (Equation 13)	Total	160	0.0672	128.59
	Regression	2	0.0002	9.83
	Residual	158	0.0670	118.76
2 (Equation 14)	Total	160	0.0672	128.59
	Regression	3	0.0003	18.13
	Residual	157	0.0669	110.45
3 (Equation 15)	Total	160	0.0672	128.59
	Regression	26	0.0409	74.60
	Residual	134	0.0263	53.99
4 (Equation 16)	Total	160	0.0672	128.59
	Regression	28	0.0416	78.10
	Residual	132	0.0256	50.49

Table 7. Regression analysis for data from experiments with soaked corn

Model no.	Variation due to	D.F.	Sum of squares	
			Standard deviation	Mean
1 (Equation 13)	Total	137	0.97	406.39
	Regression	2	0.08	44.02
	Residual	135	0.89	362.37
2 (Equation 14)	Total	137	0.97	406.39
	Regression	3	0.56	151.48
	Residual	134	0.41	254.91
3 (Equation 15)	Total	137	0.97	406.39
	Regression	22	0.87	377.92
	Residual	115	0.10	28.47
4 (Equation 16)	Total	137	0.97	406.39
	Regression	24	0.88	308.29
	Residual	113	0.10	26.10

four models shown in Equations 13 through 16.

The regression shown in model number one contains the sum of squares explained by the exposure time and voltage treatments. In model number two the regression sum of squares contains the sum of squares due to exposure time, voltage and type of field used. In model number three the regression contains the sum of squares due to type of field and the dummy variables while the regression for model number four contains the sum of squares due to exposure time, voltage, type of field and the dummy variables. The reason the regression for model number four contains the sum of squares for the type of field is that for any given experiment the type of field was the same for all six tests. Thus, the sums of squares for the type of field and for the dummy variables were not separable in this model. Since this was true, the residual for model number four contains only the sum of squares due to error and was, therefore, the residual used to test the significance of the regression due to exposure time and voltage in Table 8. The residual for the other three models contains the sum of squares due to the error plus that due to something else.

The sum of squares shown in Table 8 under standard deviation and due to exposure time and voltage was derived by subtracting the residual sum of squares of model number three in Table 4 from the residual sum of squares in model number four. This gives the sum of squares which can only be explained by the exposure time and voltage treatments. Similarly, the regression sum of squares due to the type of field shown in Table 8 was derived by subtracting the regression sum of squares in

model number one, Table 4, from the regression sum of squares in model number two. This is the sum of squares which can only be explained by the type of field used. The regression due to the dummy variable shown in Table 8 was derived by subtracting the sum of squares due to the regression in model number two, Table 4, from the sum of squares due to regression in model number four. This sum of squares can only be explained by the dummy variables (i.e., variation between experiments). The error term shown in Table 8 is taken directly from the residual of model number four shown in Table 4. In a similar fashion Tables 4 through 7 were used to derive Tables 8 through 11.

The F test values from Tables 8 through 11 have been summarized in Table 12. This shows that the sum of squares removed by the exposure time and voltage treatments was not significant at the 1 percent level for any of the data when  $\sigma$  was the dependent variable. When  $\bar{t}$  was the dependent variable, a significant portion of the sum of squares was explained at the 1 percent level by these two treatments only with dry corn and soaked corn.

The F test for the type of field used showed significance at the 1 percent level for dry soybeans and soaked corn when either  $\bar{t}$  or  $\sigma$  was used as the dependent variable. Thus, in the case of dry soybeans and soaked corn the mean time for 50 percent of the seeds to germinate was greater when an alternating (60 hertz) electric field was used than when they were treated in a static electric field. The dispersion of the data was also significantly larger for only the dry soybean and soaked corn groups when a 60 hertz alternating electric field was used as opposed



Table 8. Analysis of variance for data from experiments with air dry soybeans

Regression due to	D.F.	Standard deviation			Mean		
		Sum of squares	Mean squares	F	Sum of squares	Mean squares	F
Voltage and exposure time	2	0.75	0.38	1.48	0.18	0.09	0.08
Type of field	1	52.04	52.04	14.59	1730.57	1730.57	14.35
Dummy variables	49	174.74	3.57	-	5910.49	120.62	-
Error	251	64.12	0.26	-	274.20	1.09	-

Table 9. Analysis of variance for data from experiments with air dry corn

Regression due to	D.F.	Standard deviation			Mean		
		Sum of squares	Mean squares	F	Sum of squares	Mean squares	F
Voltage and exposure time	2	1.12	0.56	2.94	10.69	5.34	8.07
Type of field	1	5.07	5.07	4.93	106.32	106.32	5.23
Dummy variables	20	20.57	1.03	-	406.61	20.33	-
Error	108	20.62	0.19	-	71.44	0.66	-

Table 10. Analysis of variance for data from experiments with soaked soybeans

Regression due to	D.F.	Standard deviation			Mean		
		Sum of squares	Mean squares	F	Sum of squares	Mean squares	F
Voltage and exposure time	2	0.00069	0.00035	1.69	3.50	1.75	4.57
Type of field	1	0.00009	0.00009	0.05	8.31	8.31	3.46
Dummy variables	25	0.04130	0.00165	-	59.97	2.40	-
Error	132	0.02564	0.00019	-	50.49	0.38	-

Table 11. Analysis of variance for data from experiments with soaked corn

Regression due to	D.F.	Standard deviation			Mean		
		Sum of squares	Mean squares	F	Sum of squares	Mean squares	F
Voltage and exposure time	2	0.003	0.001	1.25	2.36	1.18	5.12
Type of field	1	0.48	0.475	31.58	107.46	107.46	9.87
Dummy variables	21	0.316	0.015	-	228.75	10.89	-
Error	113	0.10	0.0008	-	26.10	0.23	-

Table 12. Summary of the F test values

Seed group	F test values due to voltage and exposure time		F test values due to type of field	
	Standard deviation	Mean	Standard deviation	Mean
Dry soybeans	1.48	0.08	14.59 <sup>a</sup>	14.35 <sup>a</sup>
Dry corn	2.94	8.07 <sup>a</sup>	4.93	5.23
Soaked soybeans	1.79	4.57	0.05	3.46
Soaked corn	1.25	5.12 <sup>a</sup>	31.58 <sup>a</sup>	9.87 <sup>a</sup>

<sup>a</sup>These values are significant at the 1 percent level.

to a static electric field.

Table 13 shows the t test for the regression coefficients from model number four for exposure time and field intensity when either the standard deviation or the mean time for 50 percent of the seeds to germinate was used as the dependent variable. This table shows that the coefficient for exposure time was never significant at the 1 percent level for any group of data when either the standard deviation or the mean was used as the dependent variable. However, for dry corn the coefficient for exposure time was significant at the 5 percent level when the standard deviation was used as the dependent variable. These facts make it impossible to conclude that the exposure times which were used in this research (i.e., 1, 5, 10, 15, and 20 seconds) had any effect of economical importance on the rate of germination of these varieties of corn and soybeans when they were germinated under the experimental conditions.

Table 13. Summary of the t test values for the regression coefficients of exposure time and voltage

Seed group	Exposure time		Voltage	
	Standard deviation	Mean	Standard deviation	Mean
Dry soybeans	-1.45	-0.39	-0.21	0.07
Dry corn	-2.35	0.006	0.49	3.62 <sup>a</sup>
Soaked soybeans	-1.70	-1.58	0.04	3.02 <sup>a</sup>
Soaked corn	-0.19	1.37	-1.59	2.07

<sup>a</sup>These values are significant at the 1 percent level.

The t tests for the coefficients of voltage shown in Table 13 indicate that the field intensities used in this research (0, 500, 1000, 1500, 2000, 2500, 3000, 3500 volts with a static field and 0, 500, 1000, 1500, 2000, 2500, 3000, 3500, 4000, 4500, 5000, and 5500 volts with a 60 hertz field) had no effect on the standard deviation of the mean time for 50 percent of the seeds to germinate for any of the four groups of seeds even at the 5 percent level. Under the experimental conditions the same was true of the field intensities for dry soybeans and soaked corn when the mean time for 50 percent of the seeds to germinate,  $\bar{t}$ , was used as the dependent variable. However, for dry corn and soaked soybeans field intensity had a significant effect at the 1 percent level on the time for 50 percent of the seeds to germinate. Thus, for these two groups of seeds an increase in the field strength (or plate voltage) increased the length of time for 50 percent of the seeds to germinate.

This would tend to indicate some damage was occurring to these seeds. What was occurring on a biochemical level is not presently known, but these results even though done on seeds and not with more mature plants would tend to support Murr's (68) results.

## CONCLUSIONS

In this study it was found that electric fields affect corn and soybeans differently. Air dry seeds react differently, when subjected to an electric field, than do seeds of the same kind after being soaked for 6 hours in tap water held at  $85 \pm 2$  degrees Fahrenheit.

Other results showed that the exposure times used in this research did not cause a significant effect on the mean time for 50 percent of the seeds in an experiment to germinate or on the standard deviation of this time for any of the seeds studied. The electric field intensities used did not significantly affect the germination rate of air dry soybeans or soaked corn. The type of electric field used (static or 60 hertz) had no significant effect on the germination rate of air dry corn or soaked soybeans.

This research also supported the well-known fact that soaking seeds in water reduces the time required for germination. In addition, soybeans were shown to germinate faster than corn seeds under the conditions used in these experiments.

With due regard for the limitations under which this research was carried out and for the limitations placed upon the ranges and specific values of the variables studied, the following conclusions were drawn:

1. Treatment in an electric field did affect the germination rate of corn and soybeans.
2. Increasing the electric field intensity caused the mean time for 50 percent of the seeds to germinate to increase when working

with air dry corn or soaked soybeans.

3. For dry soybeans or soaked corn a 60 hertz electric field increased the mean time for 50 percent of the seeds to germinate significantly more than did a static field of similar intensity. The standard deviation of this mean time increased significantly at the 1 percent level only for dry soybeans or soaked corn.

## SUMMARY

This investigation was undertaken to determine if exposing soybean and corn seeds to an electric field would produce a change in the rate of germination of these seeds and if this change would be affected by electric field intensity, time of exposure and type of electric field used (i.e., a 60 hertz or a static field). The results indicate that the germination rate was changed by the applied treatments for both corn and soybeans regardless of whether they received a presoaking treatment or not. The type of electric field used appears to have a significant effect at the 1 percent level on the mean time required for 50 percent of the seeds to germinate when dry soybeans or soaked corn was used.

Field intensity caused the mean time for 50 percent of the seeds to germinate to increase as the field intensity increased for dry corn and soaked soybeans. At the 5 percent level of significance soaked corn showed similar results. No effect of field intensity was detected when working with dry soybeans.

Exposure time either had no effect or the effect was too small to detect for both seed types in either the air dry or soaked condition.

The information gleaned from this research showed that different seeds respond differently to different electrical environments. Their response also depends on their condition when treated. However, the significant effects indicate that the possibility of using electric fields to decrease the rate of germination of seeds is not unreasonable. These two



facts, the differential response of different seeds and the retardation of the germination rate, would indicate that electric fields may develop as a new method of weed control.

## SUGGESTIONS FOR FURTHER STUDY

As a direct extension of this research the following areas should be investigated:

1. Extend the range of field intensities and exposure times to higher and lower values than were used in this research.
2. Explore the effects of electrical fields on other types of seeds, particularly weed seeds.
3. Attempt to control the conditions under which seed germination occurs more closely. This would involve determining the accuracy with which the various environmental factors must be controlled to achieve the desired uniformity of germination.
4. Determine the biological changes which electric fields cause in seeds and plants.
5. Attempt to determine the interaction of electric and magnetic fields on seed germination and plant growth.
6. Determine if electric fields have more influence if applied continuously during germination.
7. Study the reaction of various seeds to the flow of electric current through them.
8. Investigate the reaction of plants to the flow of electric current through the soil.
9. Develop new, more accurate and less damaging metering systems for seeds.
10. Study the parameters, principles and field operation of the belt type metering system used in this research.

11. Develop a method of comparing the continuous line of best fit for different sets of data, particularly for nonlinear relationships.

## BIBLIOGRAPHY

1. Ark, P. A. and Willet Parry. Application of high-frequency electrostatic fields in agriculture. *Quarterly Review of Biology* 15, No. 1: 172-191. 1940.
2. Blackman, V. H. Field experiments in electro-culture. *Journal of Agricultural Science* 14, Part 2: 240-267. 1924.
3. Blackman, V. H. and A. T. Legg. Pot-culture experiments with an electric discharge. *Journal of Agricultural Science* 14, Part 2: 268-286. 1924.
4. Blackman, V. H., A. T. Legg, and F. G. Gregory. The effect of a direct electric current of very low intensity on the rate of growth of the coleoptile of barley. *Royal Society of London Proceedings, Series B*, 95: 214-228. 1923.
5. Briggs, Lyman J., A. B. Campbell, R. H. Heald, and L. H. Flint. Electroculture. *U.S. Department of Agriculture Bulletin* 1379. 1926.
6. Brown, O. A., R. B. Stone, Jr., and Henry Andrews. Methods and equipment for low energy irradiation of seeds. *Agricultural Engineering* 38: 666-669. 1957.
7. Burch, Thomas A. and James C. Delouche. Absorption of water by seeds. *Association of Official Seed Analysts Proceedings* 49: 142-150. 1959.
8. Burr, H. S. Biologic organization and the cancer problem. *Yale Journal of Biology and Medicine* 12: 277-282. 1939.
9. Burr, H. S. Electrical correlates of growth in corn roots. *Yale Journal of Biology and Medicine* 14: 581-588. 1942.
10. Burr, H. S. Electrical correlates of pure and hybrid strains of sweet corn. *National Academy of Sciences Proceedings* 29: 163-166. 1943.
11. Burr, H. S. An electro-dynamic theory of development suggested by studies of proliferation rates in the brain of Amblystoma. *Journal of Comparative Neurology* 56: 347-371. 1932.
12. Burr, Harold S. An electrometric study of cotton seeds. *Journal of Experimental Zoology* 113: 201-210. 1950.

13. Burr, H. S. An electrometric study of mimosa. *Yale Journal of Biology and Medicine* 15: 823-829. 1943.
14. Burr, H. S. Field theory in biology. *Scientific Monthly* 64, No. 3: 217-225. 1947.
15. Burr, H. S. and C. I. Hovland. Bio-electric potential gradients in the chick. *Yale Journal of Biology and Medicine* 9: 247-258. 1937.
16. Burr, H. S. and F. S. C. Northrop. The electro-dynamic theory of life. *Quarterly Review of Biology* 10: 322-333. 1935.
17. Burr, H. S. and F. S. C. Northrop. Evidence for the existence of an electro-dynamic field in living organisms. *National Academy of Sciences Proceedings* 25: 284-288. 1939.
18. Burr, Harold S. and Edmund W. Sinnott. Electrical correlates of form in cucurbit fruits. *American Journal of Botany* 31: 249-253. 1944.
19. Cherry, W. H. P. Electricity and agriculture. *Agricultural Gazette of New South Wales* 19, Part 2: 869-891. 1908.
20. Cholodny, N. G. and E. Sankewitsch. Influence of weak electric currents upon the growth of the coleoptile. *Plant Physiology* 12: 385-408. 1937.
21. Clark, W. G. Electrical polarity and auxin transport. *Plant Physiology* 13: 529-552. 1938.
22. Clark, W. G. Electrical polarity and auxin transport. *Plant Physiology* 12: 409-440. 1937.
23. Clark, W. G. Polar transport of auxin and electrical polarity in coleoptile of Avena. *Plant Physiology* 12: 737-754. 1937.
24. Collins, G. N., L. H. Flint, and J. W. McLane. Electric stimulation of plant growth. *Journal of Agricultural Research* 38: 585-600. 1929.
25. Dedolph, R. R., J. J. Green, and S. A. Gordon. Geoelectric effect and geotropic curvature. *Science* 148: 1100-1101. 1965.
26. Dexter, S. T. Separation of living and dead corn (Zea mays) kernels without germination. *Agronomy Journal* 57: 95-96. 1965.

27. Dorchester, Charles S. A study of the effect of electric current on certain crop plants. Unpublished Ph.D. thesis. Ames, Iowa, Library, Iowa State University of Science and Technology. 1935.
28. Etherton, Bud. Transmembrane potential measurements of cells of higher plants as related to salt uptake. *Science* 131: 409-410. 1960.
29. Eyster, H. C. Cause of decreased germination of bean seeds soaked in water. *American Journal of Botany* 27: 652-659. 1940.
30. Fensom, D. S. The bio-electric potentials of plants and their functional significance. II. The patterns of bio-electric potential and exudation rate in excised sunflower roots and stems. *Canadian Journal of Botany* 36: 367-383. 1958.
31. Fensom, D. S. Effects of synthetic growth regulators on the electrical potentials of red pine trees. *Journal of Forestry* 53: 915-916. 1955.
32. Freund, John E. *Mathematical statistics*. Englewood Cliffs, New Jersey, Prentice-Hall, Incorporated. 1962.
33. Glass, H. B. Effect of light on the bioelectric potentials of isolated Eloдея leaves. *Plant Physiology* 8: 263-274. 1933.
34. Hendrick, J. Experiments on the treatment of growing crops with overhead electric discharges. *Scottish Journal of Agriculture* 1: 160-171. 1918.
35. Hogan, J. T. and A. S. Roseman. Gas plasma irradiation of rice. II. Effect of heat on hydration and cooking characteristics. *Cereal Chemistry* 38: 432-438. 1961.
36. Hyman, L. H. and A. W. Bellamy. Studies on the correlation between metabolic gradients, electrical gradients, and galvanotaxis. I. *Biology Bulletin* 43: 313-347. 1922.
37. Jonas, Herbert. Some effects of radio frequency irradiations on small oilbearing seeds. *Physiologia Plantarum* 5: 41-51. 1952.
38. Kinney, Asa S. Electro-germination. Hatch Experiment Station (Mass.) Bulletin 43. 1897.
39. Larson, Gary Eugene. The bioelectric potentials surrounding the root of Zea mays. Unpublished Ph.D. thesis. Library, Rutgers State University, New Brunswick, N.J. 1964. Original not available; abstracted in *Dissertation Abstracts* 25: 6180-6181. 1965.

40. Leicester, James. The action of electric currents upon the growth of seeds and plants. The Chemical News 65: 63. 1892.
41. Leicester, James. Action of electric currents upon the growth of seeds. The Chemical News 66: 199. 1892.
42. Leighty, C. E. and J. W. Taylor. Electrochemical treatment of seed wheat. U.S. Department of Agriculture Circular 305. 1924.
43. Lemstrom, S. Electricity in agriculture and horticulture. D. Van Nostrand Co., New York, New York. 1904.
44. Lund, E. J. Experimental control of organic polarity by the electric current. V. The nature of the control of organic polarity by the electric current. Journal Experimental Zoology 41: 155-190. 1925.
45. Lund, E. J. Experimental control of organic polarity by the electric current. II. The normal electrical polarity of Obelia, a proof of its existence. Journal Experimental Zoology 36; 477-494. 1922.
46. Lund, E. J. Relation between continuous bio-electric currents and cell respiration. V. The quantitative relation between  $E_p$  and cell oxidation as shown by the effects of cyanide and oxygen. Journal Experimental Zoology 51: 327-337. 1928.
47. Lund, E. J. Relation between continuous bio-electric currents and cell respiration. II. Journal Experimental Zoology 51: 265-290. 1928.
48. Lund, E. J. Relation between continuous bio-electric currents and cell respiration. III. Effects of concentration of oxygen on cell polarity in the frog skin. Journal Experimental Zoology 51: 291-307. 1928.
49. Lund, E. J. and Collaborators. Bioelectric fields and growth. The University of Texas Press, Austin, Texas. 1947.
50. Lund, E. J. and W. A. Kenyon. Relation between continuous bio-electric currents and cell respiration. I. Electric correlation potentials in growing root tips. Journal Experimental Zoology 48: 333-357. 1927.
51. Lund, E. J., J. N. Pratley, and Hilda F. Rosene. The cytochrome electrode system and the bioelectric field of the cell. I. The E.M.F. in the root of Allium cepa. II. The E.M.F. in the frog skin. Texas University Institute of Marine Science Publications 10: 221-248. 1965.

52. Lutkova, I. N. Onekotorykh izmeneniyakh v razvittii rastenii pod vliyaniem elektrichestva na pochvu (Some changes in plant development under the influence of electricity applied to the soil). Tr. Tsentr Lab Im I.V. Michurinu 7: 266-284. 1961; Referat. Zhur., Biol. No. 1G25. 1963. Original not available; abstracted in Biological Abstracts 46: 8257. 1965.
53. Lutkova, I. N. and P. M. Oleshko. Effect of an electric current during stratification of cherry seeds. Soviet Plant Physiology 12: 201-204. 1965.
54. Marsh, Gordon. The effect of applied electric currents on inherent cellular E.M.F. and its possible significance in cell correlation. Protoplasma 11: 447-474. 1930.
55. Marsh, Gordon. Relation between continuous bio-electric currents and cell respiration. IV. The origin of electric polarity in the onion root. Journal of Experimental Zoology 51: 309-325. 1928.
56. McDonald, James E. The earth's electricity. Scientific American 188, No. 4: 32-37. 1953.
57. Molitorisz, Joseph. Engineering applications of electro-physiological properties of plants. Agricultural Science Review 4, No. 3: 8-11. 1966.
58. Monahan, N. F. The influence of the atmospherical electrical potential on plants. Hatch Experiment Station (Mass.) Annual Report 16: 31-36. 1904.
59. Monahan, N. F. The influence of electrical potentials on the growth of plants. Hatch Experiment Station (Mass.) Annual Report 17: 14-31. 1905.
60. Murr, L. E. The biophysics of plant electrotopism. New York Academy of Science Transactions 27: 759-771. 1965.
61. Murr, L. E. Biophysics of plant growth in an electrostatic field. Nature 206: 467-470. 1965.
62. Murr, L. E. Mechanism of plant-cell damage in an electrostatic field. Nature 201: 1305-1306. 1964.
63. Murr, L. E. A microscopic study of lethal electrotopism in plants. Pennsylvania Academy of Science Proceedings 38: 7-15. 1964.



64. Murr, L. E. Optical microscopy investigation of plant cell destruction in an electrostatic field. Pennsylvania Academy of Science Proceedings 37: 109-121. 1963.
65. Murr, L. E. Plant growth response following exposure to short duration electrostatic field. Pennsylvania Academy of Science Proceedings 38: 44-46. 1964.
66. Murr, L. E. Plant growth response in an electrokinetic field. Nature 207: 1177-1178. 1965.
67. Murr, L. E. Plant growth response in a simulated electric field environment. Nature 200: 490-491. 1963.
68. Murr, L. E. Plant physiology in simulated geoelectric and geomagnetic fields. Advancing Frontiers of Plant Science 15: 97-120. 1966.
69. Murr, L. E. The variation of dielectric properties of soil as a function of available moisture. Pennsylvania Academy of Science Proceedings 36: 185-193. 1962.
70. Naqir, S. M., R. R. Dedolph, and S. A. Gordon. Auxin transport and geoelectric potential in corn coleoptile sections. Plant Physiology 40: 966-968. 1965.
71. Nelson, Oliver E. and H. S. Burr. Growth correlates of electromotive forces in Maize seeds. National Academy of Sciences Proceedings 32, No. 4: 73-84. 1946.
72. Nelson, S. O., L. E. Stetson, R. B. Stone, J. C. Webb, C. A. Pettibone, D. W. Works, W. R. Kehr, and G. E. VanRiper. Comparison of infrared, radiofrequency, and gas-plasma treatments of alfalfa seed for hard-seed reduction. American Society of Agricultural Engineers Transactions 7: 276-280. 1964.
73. Nelson, S. O. and Elda R. Walker. Effects of radio-frequency electrical seed treatment. Agricultural Engineering 42: 688-691. 1961.
74. Nelson, S. O. and W. W. Wolf. Reducing hard seed in alfalfa by radio-frequency electrical seed treatment. American Society of Agricultural Engineers Transactions 7: 116-119, 122. 1964.
75. Newman, John E. Electricity and plant growth. In F. F. Fowle, editor. Standard handbook for electrical engineers. 5th edition. Pp. 1810-1811. McGraw-Hill Book Company, Incorporated, New York, New York. 1922.

76. Northrop, F. S. C. and H. S. Burr. Experimental findings concerning the electro-dynamic theory of life and an analysis of their physical meaning. *Growth* 1: 78-88. 1937.
77. Parkinson, K. J. Bio-electric potentials of intact green plants. II. Analysis of the changes in the measured bio-electric potentials of Avena sativa L. coleoptiles brought about by the application of the measuring contacts. *Journal of Experimental Botany* 17: 309-319. 1966.
78. Parkinson, K. J. and G. H. Banbury. Bio-electric potentials of intact green plants. I. Measurement of the bio-electric potentials of Avena sativa L., Var. "Barnwell." *Journal of Experimental Botany* 17: 297-308. 1966.
79. Pickett, James M. and A. R. Schrank. Responses of Avena coleoptiles to magnetic and electrical fields. *Texas Journal Science* 17: 245-258. 1965.
80. Plowman, A. B. Electromotive force in plants. *American Journal of Science, Series 4*, 15: 94-104. 1902.
81. Priestley, J. H. Experiments in the application of electricity to crop production. *Journal of the Board of Agriculture (Great Britain)* 20: 582-594. 1913.
82. Priestley, J. H. Overhead electrical discharges and plant growth. *Journal of the Board of Agriculture (London)* 17: 16-28. 1910.
83. Riccioni, Bindo. Il trattamento elettrico del seme di grano, "sistema Riccioni" dal laboratorio all'agricoltura pratica (The electrical treatment of grain seeds "System Riccioni" of the Laboratory for Practical Agriculture) [Separate booklet of 127 pages]. Original not available; translation secured from Stuart Nelson, Investigations Leader, Division of Farm Electrification, Agricultural Research Service, United States Department of Agriculture, Beltsville, Maryland. ca. 1960.
84. Roane, Thomas M. and U. F. Earp. Influence of ultraviolet, ultrasonic and electromagnetic energy on spinach seed. (Abstract) *Virginia Journal Science* 14, No. 4: 174. 1963.
85. Roseman, A. S., J. T. Hogan, R. B. Stone, and J. C. Webb. Gas plasma irradiation of rice. I. Hydration characteristics. *Cereal Chemistry* 38: 423-432. 1961.
86. Roseman, A. S., J. T. Hogan, R. B. Stone, and J. C. Webb. Gas plasma irradiation of rice. III. Influence on brown rice and rice bran. *Cereal Chemistry* 40: 568-575. 1963.

87. Ross, William. Galvanic experiments on vegetation. U.S. Patent Office Annual Report 1844: 370-373. 1844.
88. Russell, E. J. Report on the proposed electrolytic treatment of seeds (Wolfryn process before sowing). Journal of the Board of Agriculture (Great Britain) 26: 971-981. 1920.
89. Scott, B. I. H. Electric fields in plants. Annual Review of Plant Physiology 18: 409-418. 1967.
90. Shutt, Frank T. Electrolytic treatment of seed grain. Agricultural Gazette of Canada 7: 310-311. 1920.
91. Shutt, Frank T. The Wolfryn electro-chemical process for the treatment of seed grain. Agricultural Gazette of Canada 5: 762-764. 1918.
92. Sidway, G. H. Influence of electrostatic fields on seed germination. Nature 211: 303. 1966.
93. Simpson, George C. The electricity of rain and its origin in thunderstorms. Philosophical Transactions of the Royal Society of London, Series A, 209: 379-413. 1909.
94. Siniukhin, A. M. Nature of the variation of the bioelectric potentials in the regeneration process of plants. Biophysics 2: 52-69. 1957.
95. Smirnova, I. S., V. A. Tiutunnikova, and A. G. Bykovetz. Presowing treatment of seeds by the alternating current of high tension (translated title). Mekhanizatsiia i Elektrifikatsiia Sotsialisti Cheskogo Sel'skogo Khoziaistva (Mechanization and Electrification of Socialist Agriculture) 21, No. 1: 33-36. 1963. Original not available; translation secured from Stuart Nelson, Investigations Leader, Division of Farm Electrification, Agricultural Research Service, United States Department of Agriculture, Beltsville, Maryland. ca. 1960.
96. Solly, E. The influence of electricity on vegetation. Journal of the Horticultural Society (London) 1: 81-109. 1845.
97. Stone, G. E. The influence of current electricity on plant growth. Hatch Experiment Station (Mass.) Annual Report 16: 13-30. 1904.
98. Stone, George E. Influence of electricity on micro-organisms. Botanical Gazette 48: 359-379. 1909.

99. Stone, R. B., Jr. and J. R. Barrett, Jr. Effect of gas plasma radiations on cotton yarn. American Society of Agricultural Engineers Transactions 5: 46-48, 53. 1962.
100. Utah Agricultural Experiment Station. Electricity and plant growth. Utah Agricultural Experiment Station Annual Report 1893: 71-74. 1893.
101. Waller, J. C. Plant electricity. I. Photo-electric currents associated with the activity of chlorophyll in plants. Annals of Botany 39: 515-538. 1925.
102. Webb, J. C., R. B. Stone, and J. J. McDow. Response of cottonseed to audiofrequency gas plasma. American Society of Agricultural Engineers Transactions 9: 272-274, 279. 1966.
103. Webb, J. C., R. B. Stone, Jr., and J. B. Pate. Results of laboratory and field tests of gas plasma irradiated cottonseed. American Society of Agricultural Engineers Transactions 7: 412-413, 417. 1964.
104. Wheelock, John H. The effect of electricity on plant growth and production. Unpublished M.S. thesis. Library, Iowa State University of Science and Technology, Ames, Iowa. 1920.
105. Wilcox, J. B., J. R. Knight, and A. A. Bless. Bioelectric potentials of tumor-infected plants. Plant Physiology 28: 545-549. 1953.
106. Wilkins, Malcolm B. and A. E. R. Woodcock. Origin of the geoelectric effect in plants. Nature 208: 990-992. 1965.
107. Zhurbitskii, Z. I. and I. L. Shidlovskaya. Vliyanie elektricheskogo polya atmosfery na nakoplenie elementov mineral'nykh pituniya rasteniyami kukuruzy, luka, redisa i yachmenya (Effect of the electrical field of the atmosphere on the storage of mineral nutrients needed by corn, onion, radish and barley plants). Nauka. Moscow. 286-295. 1964. From Ref. Z. H. Biology No. 5G15. 1965. Original not available; abstracted in Biological Abstracts 47: 39208. 1966.

## ACKNOWLEDGMENTS

The author would like to express his sincere appreciation to:

Dr. C. W. Bockhop for serving as major professor and for his assistance in preparing this dissertation.

Mr. W. G. Lovely of the United States Department of Agriculture for his helpful suggestions, guidance, and support in carrying out this work.

Mr. Richard Chamberlain, Dr. D. Jowett, and Mr. William Kennedy for their advice and assistance on statistical problems and computer programming.

Dr. W. F. Buchele, Dr. L. F. Charity, Dr. G. W. Smith, and Dr. D. W. Staniforth for serving as graduate committee members and for their advice and suggestions in preparing this dissertation.

The United States Department of Agriculture and the Agricultural Engineering Department for providing the financial and physical facilities necessary for completion of this work.

Mr. Jim Andrew for assistance with electronics work. Mr. Robert Fish, Mr. Rex Whitcanack, and Mr. Orvil Rutzen for help with construction of equipment.

Mrs. Violet Johnson and Mrs. Kay Mikkelsen for typing and editing assistance.

The author would like to give a special note of appreciation to his wife, Marjorie, for her constant support and understanding without which this project could never have been completed.

CORRECTION SHEET

July 31, 1968

Due to a misplaced decimal point in the computer output for appendix A, the Standard Deviation values shown from pages 120 to 182, inclusive, are ten (10) times too large. For example, the standard deviation for experiment 251 should be 6.00 rather than 60.0.

Major Professor

C. W. Bockhop  
C. W. Bockhop

Head of Department

C. W. Bockhop  
C. W. Bockhop

Dean of the Graduate College

J. B. Page  
J. B. Page

APPENDIX A

Experimental and Calculated Data

EXPERIMENT NO.	251.	252.	253.	254.	255.	256.
PLATE VOLTAGE	430.	400.	300.	210.	125.	0.0
EXPOSURE TIME (SEC.)	5.	5.	5.	5.	5.	0.0
SOYBEANS - NO PRETREATMENT					D.C.	FIELD

TIME (HOURS)	NUMBER OF SEEDS GERMINATED					
19.0	10.	6.	2.	5.	2.	6.
21.0	13.	10.	4.	9.	9.	11.
23.0	31.	19.	13.	22.	20.	23.
27.0	68.	47.	45.	53.	54.	44.
31.0	90.	93.	93.	103.	95.	85.
35.0	109.	118.	115.	113.	111.	114.
39.5	123.	124.	125.	121.	123.	125.
44.0	125.	124.	125.	123.	124.	125.

MEAN TIME FOR 50 PERCENT OF SEEDS TO GERMINATE	27.2	27.8	28.4	27.4	28.0	28.3
STANDARD DEVIATION	60.0	46.0	43.0	48.0	48.0	51.0

EXPERIMENT NO.	261.	262.	263.	264.	265.	266.
PLATE VOLTAGE	430.	400.	300.	210.	125.	0.0
EXPOSURE TIME (SEC.)	5.	5.	5.	5.	5.	0.0
SOYBEANS - NO PRETREATMENT					D.C.	FIELD

TIME (HOURS)	NUMBER OF SEEDS GERMINATED					
15.0	3.	1.	4.	0.0	0.0	0.0
19.0	9.	7.	16.	1.	3.	0.0
23.0	27.	24.	30.	14.	15.	6.
27.0	47.	45.	57.	41.	25.	22.
31.0	85.	75.	96.	85.	72.	56.
36.0	115.	117.	123.	122.	119.	97.
40.0	123.	123.	125.	125.	123.	120.

MEAN TIME FOR 50 PERCENT OF SEEDS TO GERMINATE	27.8	28.4	26.6	28.7	29.6	31.3
STANDARD DEVIATION	58.0	55.0	57.0	42.0	45.0	46.0



EXPERIMENT NO.	271.	272.	273.	274.	275.	276.
PLATE VOLTAGE	430.	400.	300.	210.	125.	0.0
EXPOSURE TIME (SEC.)	10.	10.	10.	10.	10.	0.0
SOYBEANS - NO PRETREATMENT					D.C.	FIELD

TIME (HOURS)	NUMBER OF SEEDS GERMINATED					
17.0	3.	0.0	0.0	0.0	0.0	0.0
21.0	16.	7.	4.	11.	12.	11.
25.0	47.	24.	24.	24.	40.	39.
31.0	100.	91.	96.	84.	90.	100.
41.0	125.	125.	125.	125.	123.	125.

MEAN TIME FOR 50 PERCENT OF SEEDS TO GERMINATE	26.6	28.4	28.2	28.8	27.6	27.2
STANDARD DEVIATION	50.0	42.0	38.0	48.0	49.0	44.0

EXPERIMENT NO.	281.	282.	283.	284.	285.	286.
PLATE VOLTAGE	430.	400.	300.	210.	125.	0.0
EXPOSURE TIME (SEC.)	15.	15.	15.	15.	15.	15.
SOYBEANS - NO PRETREATMENT					D.C.	FIELD

TIME (HOURS)	NUMBER OF SEEDS GERMINATED					
16.0	4.	14.	4.	2.	0.0	0.0
20.0	14.	20.	12.	11.	12.	3.
25.0	48.	52.	38.	35.	44.	19.
29.0	89.	90.	89.	93.	85.	62.
40.0	125.	124.	124.	125.	125.	125.

MEAN TIME FOR 50 PERCENT OF SEEDS TO GERMINATE	26.2	25.4	26.6	26.6	26.7	29.0
STANDARD DEVIATION	51.0	63.0	48.0	42.0	47.0	41.0

EXPERIMENT NO.	291.	292.	293.	294.	295.	296.
PLATE VOLTAGE	430.	400.	300.	210.	125.	0.0
EXPOSURE TIME (SEC.)	1.	1.	1.	1.	1.	1.
SOYBEANS - NO PRETREATMENT					D.C.	FIELD

TIME (HOURS)	NUMBER OF SEEDS GERMINATED					
17.0	8.	4.	1.	1.	2.	3.
21.0	31.	25.	14.	15.	24.	17.
25.0	63.	54.	47.	37.	48.	47.
29.0	96.	91.	89.	79.	78.	83.
37.5	125.	125.	125.	124.	121.	124.

MEAN TIME FOR 50 PERCENT OF SEEDS TO GERMINATE	24.8	25.7	26.4	27.2	26.4	26.5
STANDARD DEVIATION	53.0	49.0	42.0	45.0	51.0	48.0

EXPERIMENT NO.	301.	302.	303.	304.	305.	306.
PLATE VOLTAGE	3500.	1700.	700.	0.0	1500.	1000.
EXPOSURE TIME (SEC.)	5.	5.	5.	0.0	5.	5.
SOYBEANS - NO PRETREATMENT					D.C.	FIELD

TIME (HOURS)	NUMBER OF SEEDS GERMINATED					
20.0	12.	3.	6.	9.	2.	10.
24.0	32.	29.	29.	41.	19.	26.
26.0	43.	47.	44.	50.	31.	46.
28.0	57.	61.	59.	74.	44.	62.
30.0	83.	83.	78.	99.	71.	86.
32.0	99.	100.	100.	114.	85.	99.
35.0	120.	117.	118.	122.	113.	115.
44.0	124.	125.	123.	125.	124.	125.

MEAN TIME FOR 50 PERCENT OF SEEDS TO GERMINATE	27.5	28.0	27.8	26.5	29.3	27.8
STANDARD DEVIATION	51.0	46.0	47.0	44.0	46.0	52.0

EXPERIMENT NO.	311.	312.	313.	314.	315.	316.
PLATE VOLTAGE	3500.	3000.	2500.	2000.	1500.	0.0
EXPOSURE TIME (SEC.)	5.	5.	5.	5.	5.	0.0
SOYBEANS - NO PRETREATMENT					D.C.	FIELD

TIME (HOURS)	NUMBER OF SEEDS GERMINATED					
14.0	4.	7.	3.	2.	0.0	1.
18.5	17.	21.	20.	17.	17.	12.
20.0	24.	28.	29.	29.	24.	21.
22.0	36.	41.	50.	48.	35.	34.
24.0	68.	67.	75.	68.	60.	52.
26.0	91.	92.	101.	88.	79.	73.
29.0	116.	119.	120.	114.	112.	100.
38.0	124.	125.	124.	124.	125.	122.

MEAN TIME FOR 50 PERCENT OF SEEDS TO GERMINATE	23.4	23.0	22.6	23.3	24.1	24.7
STANDARD DEVIATION	42.0	46.0	39.0	43.0	42.0	46.0

EXPERIMENT NO.	321.	322.	323.	324.	325.	326.
PLATE VOLTAGE	3500.	3000.	2500.	2000.	1500.	0.0
EXPOSURE TIME (SEC.)	5.	5.	5.	5.	5.	0.0
SOYBEANS - NO PRETREATMENT					D.C.	FIELD

TIME (HOURS)	NUMBER OF SEEDS GERMINATED					
15.5	2.	0.0	0.0	1.	0.0	0.0
18.0	5.	5.	1.	3.	5.	6.
20.0	11.	7.	6.	10.	8.	10.
22.5	30.	28.	10.	17.	18.	20.
24.5	50.	51.	16.	36.	37.	29.
26.0	62.	60.	27.	59.	53.	42.
31.0	108.	103.	77.	108.	104.	108.
35.0	124.	120.	121.	122.	123.	126.

MEAN TIME FOR 50 PERCENT OF SEEDS TO GERMINATE	25.8	25.9	28.7	26.2	26.6	26.8
STANDARD DEVIATION	44.0	42.0	40.0	39.0	41.0	41.0

EXPERIMENT NO.	331.	332.	333.	334.	335.	336.
PLATE VOLTAGE	3500.	3500.	3500.	0.0	0.0	0.0
EXPOSURE TIME (SEC.)	20.	5.	1.	0.0	0.0	0.0
SOYBEANS - NO PRETREATMENT					D.C.	FIELD

TIME (HOURS)	NUMBER OF SEEDS GERMINATED					
14.5	9.	4.	3.	7.	0.0	0.0
17.0	20.	13.	14.	13.	0.0	0.0
19.0	34.	27.	25.	23.	0.0	0.0
21.5	49.	40.	37.	50.	0.0	0.0
23.5	69.	65.	54.	75.	0.0	0.0
25.0	87.	89.	85.	93.	0.0	0.0
30.0	125.	120.	123.	123.	0.0	0.0
34.0	125.	125.	125.	124.	0.0	0.0

MEAN TIME FOR 50 PERCENT OF SEEDS TO GERMINATE	22.7	23.4	23.6	22.8	0.0	0.0
STANDARD DEVIATION	47.0	43.0	41.0	41.0	0.0	0.0

EXPERIMENT NO.	341.	342.	343.	344.	345.	346.
PLATE VOLTAGE	0.0	0.0	0.0	0.0	0.0	0.0
EXPOSURE TIME (SEC.)	0.0	0.0	0.0	0.0	0.0	0.0
SOYBEANS - NO PRETREATMENT					D.C.	FIELD

TIME (HOURS)	NUMBER OF SEEDS GERMINATED					
13.0	1.	1.	0.0	2.	1.	2.
20.5	8.	11.	6.	4.	7.	13.
23.0	29.	25.	19.	15.	23.	28.
26.0	56.	46.	48.	32.	48.	52.
29.0	78.	72.	67.	66.	73.	71.
31.5	103.	92.	94.	94.	93.	90.
34.0	118.	114.	112.	118.	115.	114.
43.0	125.	125.	123.	125.	124.	125.

MEAN TIME FOR 50 PERCENT OF SEEDS TO GERMINATE	27.0	27.8	28.0	28.4	27.7	27.6
STANDARD DEVIATION	45.0	50.0	46.0	42.0	46.0	52.0

EXPERIMENT NO.	351.	352.	353.	354.	355.	356.
PLATE VOLTAGE	0.0	0.0	0.0	0.0	0.0	0.0
EXPOSURE TIME (SEC.)	0.0	0.0	0.0	0.0	0.0	0.0
SOYBEANS - NO PRETREATMENT					D.C.	FIELD

TIME (HOURS)	NUMBER OF SEEDS GERMINATED					
17.0	2.	5.	5.	5.	4.	9.
19.5	13.	13.	14.	16.	13.	16.
22.0	24.	22.	26.	27.	20.	24.
25.0	45.	44.	43.	47.	34.	45.
28.0	72.	85.	75.	79.	62.	70.
30.5	88.	108.	103.	104.	90.	90.
33.0	115.	122.	122.	120.	116.	112.
42.0	123.	125.	125.	123.	125.	124.

MEAN TIME FOR 50 PERCENT OF SEEDS TO GERMINATE	26.6	25.9	26.1	25.8	27.3	26.6
STANDARD DEVIATION	50.0	44.0	47.0	47.0	50.0	57.0

EXPERIMENT NO.	361.	362.	363.	364.	365.	366.
PLATE VOLTAGE	3500.	3000.	2500.	2000.	1500.	0.0
EXPOSURE TIME (SEC.)	5.	5.	5.	5.	5.	0.0
SOYBEANS - NO PRETREATMENT					D.C.	FIELD

TIME (HOURS)	NUMBER OF SEEDS GERMINATED					
18.5	6.	6.	2.	3.	3.	5.
20.5	6.	6.	2.	3.	3.	9.
23.5	15.	12.	9.	16.	14.	21.
27.0	32.	31.	36.	36.	36.	43.
30.0	61.	68.	65.	65.	66.	70.
33.0	95.	97.	90.	98.	94.	99.
42.5	125.	124.	124.	125.	125.	125.

MEAN TIME FOR 50 PERCENT OF SEEDS TO GERMINATE	29.7	29.4	29.9	29.4	29.6	28.8
STANDARD DEVIATION	52.0	50.0	47.0	48.0	49.0	53.0

EXPERIMENT NO.	371.	372.	373.	374.	375.	376.
PLATE VOLTAGE	3500.	3500.	3500.	3500.	3500.	0.0
EXPOSURE TIME (SEC.)	20.	15.	10.	5.	1.	0.0
SOYBEANS - NO PRETREATMENT					D.C.	FIELD

TIME (HOURS)	NUMBER OF SEEDS GERMINATED					
17.0	16.	14.	11.	7.	3.	9.
19.0	22.	20.	16.	11.	5.	11.
22.0	35.	29.	26.	22.	19.	17.
25.5	53.	57.	48.	38.	37.	37.
28.5	86.	92.	76.	72.	78.	64.
31.5	112.	118.	107.	108.	105.	96.
41.0	124.	125.	124.	125.	125.	125.

MEAN TIME FOR 50 PERCENT OF SEEDS TO GERMINATE	25.1	24.9	26.2	26.9	27.2	27.7
STANDARD DEVIATION	60.0	52.0	57.0	51.0	46.0	58.0

EXPERIMENT NO.	381.	382.	383.	384.	385.	386.
PLATE VOLTAGE	3000.	3000.	3000.	3000.	3000.	0.0
EXPOSURE TIME (SEC.)	20.	15.	10.	5.	1.	0.0
SOYBEANS - NO PRETREATMENT					D.C.	FIELD

TIME (HOURS)	NUMBER OF SEEDS GERMINATED					
17.5	0.0	3.	1.	2.	1.	7.
20.0	9.	12.	12.	5.	8.	15.
23.5	24.	24.	24.	14.	22.	28.
26.0	44.	49.	46.	33.	46.	44.
29.0	73.	76.	75.	90.	66.	67.
31.0	102.	100.	93.	89.	97.	90.
34.0	118.	117.	119.	105.	116.	107.
41.5	125.	124.	124.	124.	124.	125.

MEAN TIME FOR 50 PERCENT OF SEEDS TO GERMINATE	27.4	27.1	27.4	28.3	27.7	27.8
STANDARD DEVIATION	44.0	47.0	46.0	47.0	45.0	59.0

EXPERIMENT NO.	391.	392.	393.	394.	395.	396.
PLATE VOLTAGE	2500.	2500.	2500.	2500.	2500.	0.0
EXPOSURE TIME (SEC.)	20.	15.	10.	5.	1.	0.0
SOYBEANS - NO PRETREATMENT					D.C.	FIELD

TIME (HOURS)	NUMBER OF SEEDS GERMINATED					
15.5	5.	2.	5.	5.	8.	3.
18.0	15.	14.	14.	14.	16.	9.
21.5	28.	29.	35.	29.	36.	29.
24.0	47.	44.	62.	48.	48.	50.
27.0	77.	72.	89.	87.	87.	76.
29.0	102.	98.	106.	109.	108.	102.
32.0	118.	121.	123.	124.	124.	113.
39.5	123.	125.	124.	125.	125.	125.

MEAN TIME FOR 50 PERCENT OF SEEDS TO GERMINATE	24.8	25.2	24.0	24.4	24.1	25.3
STANDARD DEVIATION	49.0	47.0	45.0	44.0	48.0	49.0

EXPERIMENT NO.	401.	402.	403.	404.	405.	406.
PLATE VOLTAGE	2000.	2000.	2000.	2000.	2000.	0.0
EXPOSURE TIME (SEC.)	20.	15.	10.	5.	1.	0.0
SOYBEANS - NO PRETREATMENT					D.C.	FIELD

TIME (HOURS)	NUMBER OF SEEDS GERMINATED					
17.0	3.	1.	0.0	0.0	1.	3.
19.5	5.	4.	4.	7.	2.	12.
22.0	11.	10.	14.	13.	11.	23.
26.0	34.	36.	30.	32.	37.	45.
29.0	80.	70.	52.	57.	71.	70.
31.5	110.	100.	82.	87.	96.	89.
33.5	117.	114.	104.	102.	115.	111.
41.0	125.	125.	125.	123.	125.	124.

MEAN TIME FOR 50 PERCENT OF SEEDS TO GERMINATE	27.6	28.1	29.3	28.9	28.1	27.5
STANDARD DEVIATION	41.0	42.0	48.0	50.0	42.0	55.0

EXPERIMENT NO.	411.	412.	413.	414.	415.	416.
PLATE VOLTAGE	1500.	1500.	1500.	1500.	1500.	0.0
EXPOSURE TIME (SEC.)	20.	15.	10.	5.	1.	0.0
SOYBEANS - NO PRETREATMENT					D.C.	FIELD

TIME (HOURS)	NUMBER OF SEEDS GERMINATED					
15.5	1.	0.0	4.	3.	1.	1.
18.0	10.	10.	10.	9.	6.	9.
20.5	18.	22.	18.	21.	12.	17.
24.5	46.	42.	44.	49.	46.	46.
27.5	79.	82.	85.	86.	84.	87.
30.0	108.	112.	109.	111.	103.	115.
32.0	119.	119.	119.	118.	115.	123.
39.5	125.	125.	125.	124.	124.	125.

MEAN TIME FOR 50 PERCENT OF SEEDS TO GERMINATE	25.6	25.4	25.3	25.0	25.7	25.2
STANDARD DEVIATION	44.0	44.0	46.0	45.0	42.0	40.0

EXPERIMENT NO.	421.	422.	423.	424.	425.	426.
PLATE VOLTAGE	1000.	1000.	1000.	1000.	1000.	0.0
EXPOSURE TIME (SEC.)	20.	15.	10.	5.	1.	0.0
SOYBEANS - NO PRETREATMENT					D.C.	FIELD

TIME (HOURS)	NUMBER OF SEEDS GERMINATED					
17.0	0.0	0.0	0.0	0.0	0.0	0.0
22.0	0.0	0.0	0.0	1.	0.0	0.0
26.0	0.0	0.0	0.0	2.	1.	0.0
30.0	0.0	5.	5.	7.	7.	6.
35.0	4.	11.	20.	21.	18.	21.
40.5	25.	38.	37.	49.	48.	39.
44.5	51.	62.	67.	75.	74.	68.
48.0	79.	90.	94.	98.	103.	98.
52.0	108.	118.	120.	124.	122.	121.
55.0	123.	125.	124.	125.	125.	124.

MEAN TIME FOR 50 PERCENT OF SEEDS TO GERMINATE	45.5	43.7	42.9	41.8	42.0	42.6
STANDARD DEVIATION	53.0	62.0	64.0	67.0	63.0	64.0



EXPERIMENT NO.	431.	432.	433.	434.	435.	436.
PLATE VOLTAGE	500.	500.	500.	500.	500.	0.0
EXPOSURE TIME (SEC.)	20.	15.	10.	5.	1.	0.0
SOYBEANS - NO PRETREATMENT					D.C.	FIELD

TIME (HOURS)	NUMBER OF SEEDS GERMINATED					
15.0	0.0	0.0	0.0	0.0	0.0	0.0
20.0	6.	10.	2.	2.	1.	2.
24.0	13.	15.	3.	5.	8.	4.
28.0	19.	22.	17.	11.	16.	11.
33.0	47.	44.	39.	32.	44.	38.
38.5	90.	81.	77.	68.	79.	78.
42.5	113.	109.	103.	99.	109.	102.
46.5	123.	120.	122.	121.	125.	120.

MEAN TIME FOR 50 PERCENT OF SEEDS TO GERMINATE	34.0	34.0	35.7	36.5	35.3	35.8
STANDARD DEVIATION	66.0	73.0	62.0	61.0	63.0	59.0

EXPERIMENT NO.	441.	442.	443.	444.	445.	446.
PLATE VOLTAGE	1000.	1000.	1000.	1000.	1000.	0.0
EXPOSURE TIME (SEC.)	20.	15.	10.	5.	1.	0.0
SOYBEANS - NO PRETREATMENT					D.C.	FIELD

TIME (HOURS)	NUMBER OF SEEDS GERMINATED					
17.0	1.	2.	3.	1.	2.	0.0
23.5	3.	3.	6.	5.	13.	4.
25.0	12.	10.	20.	16.	31.	21.
28.5	26.	23.	32.	34.	56.	37.
31.0	46.	37.	52.	61.	81.	61.
36.0	84.	74.	86.	101.	110.	93.
41.0	111.	109.	121.	125.	123.	122.
45.0	123.	122.	123.	125.	125.	123.

MEAN TIME FOR 50 PERCENT OF SEEDS TO GERMINATE	32.9	33.8	31.7	31.1	28.9	31.1
STANDARD DEVIATION	59.0	60.0	62.0	51.0	59.0	56.0

EXPERIMENT NO.	451.	452.	453.	454.	455.	456.
PLATE VOLTAGE	500.	500.	500.	500.	500.	0.0
EXPOSURE TIME (SEC.)	20.	15.	10.	5.	1.	0.0
SOYBEANS - NO PRETREATMENT					D.C.	FIELD

TIME (HOURS)	NUMBER OF SEEDS GERMINATED					
15.5	3.	0.0	0.0	0.0	0.0	0.0
19.0	6.	5.	3.	2.	1.	11.
23.5	33.	18.	12.	26.	16.	28.
27.0	58.	43.	46.	56.	40.	47.
29.5	80.	74.	78.	84.	59.	73.
34.5	114.	112.	118.	118.	106.	103.
39.5	124.	125.	125.	124.	124.	123.
42.5	124.	125.	125.	124.	125.	125.

MEAN TIME FOR 50 PERCENT OF SEEDS TO GERMINATE	27.2	28.4	28.3	27.4	29.4	28.3
STANDARD DEVIATION	53.0	47.0	40.0	43.0	48.0	59.0

EXPERIMENT NO.	1171.	1172.	1173.	1174.	1175.	1176.
PLATE VOLTAGE	3500.	3000.	2000.	1000.	500.	0.0
EXPOSURE TIME (SEC.)	20.	20.	20.	20.	20.	0.0
SOYBEANS - NO PRETREATMENT					D.C.	FIELD

TIME (HOURS)	NUMBER OF SEEDS GERMINATED					
26.5	1.	0.0	2.	3.	1.	4.
30.0	9.	10.	7.	15.	8.	15.
33.0	32.	55.	49.	36.	40.	44.
36.5	74.	81.	79.	79.	87.	86.
40.0	99.	100.	105.	102.	106.	99.
44.5	114.	118.	119.	117.	118.	114.
49.5	115.	121.	120.	120.	121.	118.
60.5	120.	122.	124.	121.	122.	123.
67.5	122.	122.	124.	122.	122.	123.

MEAN TIME FOR 50 PERCENT OF SEEDS TO GERMINATE	36.5	35.0	35.4	35.5	35.1	35.4
STANDARD DEVIATION	61.0	47.0	50.0	53.0	42.0	58.0

EXPERIMENT NO.	1181.	1182.	1183.	1184.	1185.	1186.
PLATE VOLTAGE	3500.	3000.	2000.	1000.	500.	0.0
EXPOSURE TIME (SEC.)	10.	10.	10.	10.	10.	0.0
SOYBEANS - NO PRETREATMENT					D.C.	FIELD

TIME (HOURS)	NUMBER OF SEEDS GERMINATED					
23.0	0.0	0.0	0.0	0.0	0.0	0.0
26.0	4.	6.	8.	7.	3.	10.
29.5	17.	13.	24.	21.	13.	25.
32.5	33.	37.	51.	51.	40.	57.
36.0	64.	77.	90.	76.	74.	83.
39.5	86.	96.	108.	92.	95.	101.
44.0	113.	112.	116.	107.	117.	110.
49.0	117.	116.	122.	116.	122.	114.
60.0	122.	121.	123.	119.	125.	120.
67.0	124.	122.	124.	121.	125.	123.

MEAN TIME FOR 50 PERCENT OF SEEDS TO GERMINATE	36.6	35.6	34.1	35.3	35.6	34.8
STANDARD DEVIATION	68.0	63.0	58.0	71.0	54.0	77.0

EXPERIMENT NO.	1191.	1192.	1193.	1194.	1195.	1196.
PLATE VOLTAGE	3500.	3500.	3500.	3500.	3500.	0.0
EXPOSURE TIME (SEC.)	1.	1.	1.	1.	1.	0.0
SOYBEANS - NO PRETREATMENT					D.C.	FIELD

TIME (HOURS)	NUMBER OF SEEDS GERMINATED					
22.5	0.0	0.0	0.0	0.0	0.0	0.0
26.0	2.	4.	9.	9.	4.	14.
29.0	10.	14.	25.	24.	20.	32.
32.5	34.	52.	44.	56.	56.	61.
36.0	72.	83.	89.	98.	96.	102.
39.0	92.	103.	109.	111.	110.	115.
44.0	109.	118.	119.	119.	117.	118.
48.5	113.	121.	122.	124.	119.	118.
59.5	118.	124.	124.	125.	123.	120.

MEAN TIME FOR 50 PERCENT OF SEEDS TO GERMINATE	35.6	34.4	33.7	33.2	33.5	32.1
STANDARD DEVIATION	55.0	52.0	52.0	51.0	51.0	47.0

EXPERIMENT NO.	461.	462.	463.	464.	465.	466.
PLATE VOLTAGE	5000.	5000.	5000.	5000.	5000.	0.0
EXPOSURE TIME (SEC.)	20.	15.	10.	5.	1.	0.0
SOYBEANS - NO PRETREATMENT					A.C.	FIELD

TIME (HOURS)	NUMBER OF SEEDS GERMINATED					
21.0	2.	0.0	1.	0.0	3.	2.
26.0	3.	4.	5.	7.	11.	8.
30.0	9.	15.	12.	16.	24.	13.
32.5	17.	21.	13.	21.	28.	18.
36.0	23.	26.	20.	31.	38.	24.
38.0	25.	33.	29.	39.	53.	28.
44.5	50.	54.	74.	73.	77.	51.
49.0	71.	72.	101.	94.	95.	67.
52.5	94.	96.	115.	113.	113.	95.
56.0	117.	119.	125.	124.	124.	119.

MEAN TIME FOR 50 PERCENT OF SEEDS TO GERMINATE	44.4	43.6	42.3	41.6	40.1	44.1
STANDARD DEVIATION	87.0	92.0	76.0	85.0	96.0	95.0

EXPERIMENT NO.	471.	472.	473.	474.	475.	476.
PLATE VOLTAGE	4000.	4000.	4000.	4000.	4000.	0.0
EXPOSURE TIME (SEC.)	20.	15.	10.	5.	1.	0.0
SOYBEANS - NO PRETREATMENT					A.C.	FIELD

TIME (HOURS)	NUMBER OF SEEDS GERMINATED					
18.5	5.	3.	4.	1.	1.	2.
23.5	15.	14.	12.	11.	4.	5.
27.5	30.	29.	21.	17.	14.	12.
30.0	46.	40.	32.	29.	29.	20.
33.5	68.	62.	47.	42.	54.	37.
35.5	89.	79.	62.	60.	77.	52.
42.0	119.	117.	100.	102.	96.	80.
46.5	123.	124.	120.	118.	108.	105.
50.0	124.	125.	124.	121.	118.	116.
53.5	125.	125.	124.	124.	125.	124.

MEAN TIME FOR 50 PERCENT OF SEEDS TO GERMINATE	31.9	32.8	34.8	35.4	35.7	37.9
STANDARD DEVIATION	69.0	70.0	77.0	73.0	77.0	81.0

EXPERIMENT NO.	481.	482.	483.	484.	485.	486.
PLATE VOLTAGE	3500.	3500.	3500.	3500.	3500.	0.0
EXPOSURE TIME (SEC.)	20.	15.	10.	5.	1.	0.0
SOYBEANS - NO PRETREATMENT					A.C.	FIELD

TIME (HOURS)	NUMBER OF SEEDS GERMINATED					
24.0	7.	7.	3.	6.	10.	7.
28.5	18.	10.	14.	24.	30.	19.
31.5	28.	30.	24.	40.	46.	31.
33.5	36.	38.	37.	48.	55.	48.
38.5	74.	69.	68.	84.	86.	90.
43.5	111.	111.	96.	111.	104.	107.
50.0	125.	124.	122.	122.	125.	124.

MEAN TIME FOR 50 PERCENT OF SEEDS TO GERMINATE	36.2	36.5	37.2	34.8	34.5	35.2
STANDARD DEVIATION	66.0	63.0	66.0	66.0	78.0	66.0

EXPERIMENT NO.	491.	492.	493.	494.	495.	496.
PLATE VOLTAGE	3000.	3000.	3000.	3000.	3000.	0.0
EXPOSURE TIME (SEC.)	20.	15.	10.	5.	1.	0.0
SOYBEANS - NO PRETREATMENT					A.C.	FIELD

TIME (HOURS)	NUMBER OF SEEDS GERMINATED					
23.0	12.	10.	8.	16.	7.	17.
27.5	40.	30.	32.	42.	30.	36.
30.5	57.	53.	49.	62.	48.	61.
32.5	71.	72.	62.	78.	68.	72.
37.5	107.	105.	98.	112.	109.	109.
42.5	122.	124.	121.	124.	124.	123.
45.0	124.	124.	123.	125.	124.	123.

MEAN TIME FOR 50 PERCENT OF SEEDS TO GERMINATE	30.8	31.3	32.0	30.1	31.5	30.4
STANDARD DEVIATION	60.0	55.0	59.0	59.0	51.0	60.0

EXPERIMENT NO.	501.	502.	503.	504.	505.	506.
PLATE VOLTAGE	2500.	2500.	2500.	2500.	2500.	0.0
EXPOSURE TIME (SEC.)	20.	15.	10.	5.	1.	0.0
SOYBEANS - NO PRETREATMENT					A.C.	FIELD

TIME (HOURS)	NUMBER OF SEEDS GERMINATED					
21.0	4.	2.	4.	2.	5.	2.
25.0	18.	13.	11.	14.	21.	17.
28.0	45.	27.	32.	31.	31.	39.
32.0	69.	50.	59.	61.	61.	68.
34.5	96.	82.	90.	86.	78.	88.
37.0	109.	102.	105.	100.	92.	103.
41.0	122.	122.	121.	121.	119.	121.
45.0	125.	125.	124.	123.	125.	125.

MEAN TIME FOR 50 PERCENT OF SEEDS TO GERMINATE	30.6	32.4	31.7	31.7	32.0	31.3
STANDARD DEVIATION	54.0	51.0	51.0	52.0	62.0	55.0

EXPERIMENT NO.	511.	512.	513.	514.	515.	516.
PLATE VOLTAGE	2000.	2000.	2000.	2000.	2000.	0.0
EXPOSURE TIME (SEC.)	20.	15.	10.	5.	1.	0.0
SOYBEANS - NO PRETREATMENT					A.C.	FIELD

TIME (HOURS)	NUMBER OF SEEDS GERMINATED					
21.0	0.0	0.0	1.	0.0	0.0	0.0
24.0	1.	2.	1.	5.	7.	3.
28.0	12.	10.	11.	13.	16.	10.
30.5	31.	25.	21.	19.	28.	24.
33.0	46.	40.	34.	39.	55.	38.
37.0	84.	96.	82.	86.	93.	81.
41.0	114.	121.	111.	118.	112.	114.
46.0	124.	125.	122.	124.	122.	125.

MEAN TIME FOR 50 PERCENT OF SEEDS TO GERMINATE	34.4	34.1	34.9	34.5	33.6	35.0
STANDARD DEVIATION	48.0	41.0	46.0	46.0	51.0	48.0

EXPERIMENT NO.	521.	522.	523.	524.	525.	526.
PLATE VOLTAGE	1500.	1500.	1500.	1500.	1500.	0.0
EXPOSURE TIME (SEC.)	20.	15.	10.	5.	1.	0.0
SOYBEANS - NO PRETREATMENT					A.C.	FIELD

TIME (HOURS)	NUMBER OF SEEDS GERMINATED					
22.0	14.	13.	11.	11.	7.	10.
24.5	26.	24.	20.	16.	14.	20.
28.0	41.	42.	34.	38.	32.	36.
31.0	62.	59.	54.	61.	53.	65.
35.5	103.	95.	98.	99.	79.	93.
38.0	113.	113.	115.	114.	102.	107.
42.5	123.	124.	124.	124.	125.	119.
46.5	124.	125.	125.	125.	125.	124.

MEAN TIME FOR 50 PERCENT OF SEEDS TO GERMINATE	30.1	30.5	31.0	30.8	32.1	31.0
STANDARD DEVIATION	61.0	63.0	58.0	57.0	60.0	64.0

EXPERIMENT NO.	531.	532.	533.	534.	535.	536.
PLATE VOLTAGE	1000.	1000.	1000.	1000.	1000.	0.0
EXPOSURE TIME (SEC.)	20.	15.	10.	5.	1.	0.0
SOYBEANS - NO PRETREATMENT					A.C.	FIELD

TIME (HOURS)	NUMBER OF SEEDS GERMINATED					
19.0	1.	0.0	1.	1.	2.	0.0
25.0	2.	12.	9.	10.	7.	7.
28.0	10.	19.	10.	16.	13.	13.
32.5	34.	34.	35.	36.	31.	26.
35.0	49.	54.	54.	53.	44.	41.
39.5	90.	90.	97.	97.	88.	84.
42.5	111.	114.	116.	121.	115.	111.
46.0	116.	123.	123.	125.	120.	121.
49.0	125.	125.	125.	125.	124.	125.

MEAN TIME FOR 50 PERCENT OF SEEDS TO GERMINATE	36.1	35.2	35.3	34.9	35.9	36.4
STANDARD DEVIATION	58.0	61.0	56.0	56.0	59.0	57.0

EXPERIMENT NO.	541.	542.	543.	544.	545.	546.
PLATE VOLTAGE	500.	500.	500.	500.	500.	0.0
EXPOSURE TIME (SEC.)	20.	15.	10.	5.	1.	0.0
SOYBEANS - NO PRETREATMENT					A.C.	FIELD

TIME (HOURS)	NUMBER OF SEEDS GERMINATED					
16.0	0.0	0.0	0.0	0.0	0.0	0.0
22.0	0.0	0.0	1.	0.0	5.	5.
24.5	3.	3.	5.	5.	9.	9.
29.0	19.	14.	13.	22.	31.	27.
32.5	39.	34.	43.	57.	59.	54.
36.5	74.	72.	88.	95.	95.	83.
40.5	108.	104.	109.	116.	111.	110.
45.0	122.	124.	122.	124.	124.	123.

MEAN TIME FOR 50 PERCENT OF SEEDS TO GERMINATE	34.7	35.3	34.1	33.1	32.7	33.3
STANDARD DEVIATION	49.0	48.0	47.0	46.0	56.0	57.0

EXPERIMENT NO.	551.	552.	553.	554.	555.	556.
PLATE VOLTAGE	5500.	5500.	5500.	5500.	5500.	0.0
EXPOSURE TIME (SEC.)	20.	15.	10.	5.	1.	0.0
SOYBEANS - NO PRETREATMENT					A.C.	FIELD

TIME (HOURS)	NUMBER OF SEEDS GERMINATED					
15.0	0.0	0.0	0.0	0.0	0.0	0.0
21.0	6.	7.	9.	5.	10.	4.
23.5	20.	21.	14.	13.	14.	16.
28.0	45.	36.	32.	38.	33.	37.
31.5	88.	71.	55.	64.	55.	64.
35.5	110.	98.	91.	100.	95.	99.
39.5	123.	122.	117.	121.	118.	120.
44.0	124.	125.	124.	125.	124.	125.

MEAN TIME FOR 50 PERCENT OF SEEDS TO GERMINATE	29.1	30.4	31.5	30.8	31.2	30.8
STANDARD DEVIATION	49.0	56.0	59.0	53.0	58.0	54.0



EXPERIMENT NO.	561.	562.	563.	564.	565.	566.
PLATE VOLTAGE	5000.	5000.	5000.	5000.	5000.	0.0
EXPOSURE TIME (SEC.)	20.	15.	10.	5.	1.	0.0
SOYBEANS - NO PRETREATMENT					A.C.	FIELD

TIME (HOURS)	NUMBER OF SEEDS GERMINATED					
17.0	0.0	0.0	0.0	1.	0.0	1.
25.0	5.	3.	10.	17.	18.	11.
27.5	13.	16.	22.	28.	31.	21.
31.0	31.	27.	40.	54.	50.	54.
35.5	62.	53.	75.	99.	79.	81.
40.0	97.	97.	110.	112.	112.	104.
43.5	119.	116.	121.	123.	121.	116.
46.0	123.	124.	124.	125.	124.	125.

MEAN TIME FOR 50 PERCENT OF SEEDS TO GERMINATE	34.9	35.5	33.4	31.6	32.4	33.0
STANDARD DEVIATION	54.0	55.0	56.0	58.0	61.0	64.0

EXPERIMENT NO.	571.	572.	573.	574.	575.	576.
PLATE VOLTAGE	4500.	4500.	4500.	4500.	4500.	0.0
EXPOSURE TIME (SEC.)	20.	15.	10.	5.	1.	0.0
SOYBEANS - NO PRETREATMENT					A.C.	FIELD

TIME (HOURS)	NUMBER OF SEEDS GERMINATED					
16.0	1.	0.0	0.0	0.0	0.0	0.0
24.0	15.	16.	12.	17.	14.	18.
26.5	31.	26.	23.	29.	25.	34.
30.0	51.	49.	46.	52.	47.	63.
34.5	91.	91.	90.	97.	82.	96.
39.0	117.	116.	121.	121.	112.	122.
42.5	124.	124.	124.	124.	123.	125.
45.0	124.	124.	125.	125.	125.	125.

MEAN TIME FOR 50 PERCENT OF SEEDS TO GERMINATE	30.7	31.0	31.3	30.5	31.7	29.9
STANDARD DEVIATION	56.0	53.0	49.0	52.0	58.0	53.0

EXPERIMENT NO.	581.	582.	583.	584.	585.	586.
PLATE VOLTAGE	4000.	4000.	4000.	4000.	4000.	0.0
EXPOSURE TIME (SEC.)	20.	15.	10.	5.	1.	0.0
SOYBEANS - NO PRETREATMENT					A.C.	FIELD

TIME (HOURS)	NUMBER OF SEEDS GERMINATED					
18.5	1.	0.0	0.0	2.	0.0	0.0
23.5	5.	2.	2.	8.	6.	6.
27.5	21.	15.	12.	19.	17.	12.
29.5	33.	26.	24.	35.	34.	18.
33.0	61.	48.	46.	67.	63.	42.
35.5	85.	67.	65.	86.	88.	63.
39.0	108.	97.	99.	115.	105.	105.
43.0	124.	114.	121.	125.	115.	120.
46.0	125.	122.	125.	125.	123.	125.

MEAN TIME FOR 50 PERCENT OF SEEDS TO GERMINATE	32.8	34.4	34.6	32.3	33.0	34.6
STANDARD DEVIATION	52.0	54.0	51.0	52.0	56.0	52.0

EXPERIMENT NO.	591.	592.	593.	594.	595.	596.
PLATE VOLTAGE	3500.	3500.	3500.	3500.	3500.	0.0
EXPOSURE TIME (SEC.)	20.	15.	10.	5.	1.	0.0
SOYBEANS - NO PRETREATMENT					A.C.	FIELD

TIME (HOURS)	NUMBER OF SEEDS GERMINATED					
18.0	5.	6.	3.	1.	2.	1.
23.0	9.	13.	19.	10.	6.	11.
27.0	26.	36.	34.	39.	26.	29.
29.0	41.	48.	60.	52.	40.	39.
32.5	77.	75.	90.	86.	70.	72.
35.0	98.	94.	105.	101.	89.	98.
38.5	121.	121.	124.	123.	111.	115.
42.5	124.	125.	124.	124.	122.	122.
45.5	125.	125.	124.	125.	124.	123.

MEAN TIME FOR 50 PERCENT OF SEEDS TO GERMINATE	30.7	30.2	29.1	29.9	31.5	30.9
STANDARD DEVIATION	53.0	59.0	51.0	50.0	55.0	53.0

EXPERIMENT NO.	601.	602.	603.	604.	605.	606.
PLATE VOLTAGE	3000.	3000.	3000.	3000.	3000.	0.0
EXPOSURE TIME (SEC.)	20.	15.	10.	5.	1.	0.0
SOYBEANS - NO PRETREATMENT					A.C.	FIELD

TIME (HOURS)	NUMBER OF SEEDS GERMINATED					
19.5	2.	3.	1.	1.	2.	2.
22.0	6.	3.	8.	3.	4.	5.
25.5	16.	10.	15.	15.	11.	14.
29.5	27.	20.	28.	28.	31.	24.
34.0	55.	48.	57.	62.	53.	54.
36.0	66.	63.	76.	81.	64.	69.
40.0	99.	96.	110.	112.	100.	103.
44.0	108.	112.	122.	124.	115.	113.
48.5	123.	125.	125.	125.	124.	122.

MEAN TIME FOR 50 PERCENT OF SEEDS TO GERMINATE	34.6	35.4	33.6	33.4	34.5	34.4
STANDARD DEVIATION	71.0	65.0	60.0	56.0	65.0	64.0

EXPERIMENT NO.	611.	612.	613.	614.	615.	616.
PLATE VOLTAGE	2500.	2500.	2500.	2500.	2500.	0.0
EXPOSURE TIME (SEC.)	20.	15.	10.	5.	1.	0.0
SOYBEANS - NO PRETREATMENT					A.C.	FIELD

TIME (HOURS)	NUMBER OF SEEDS GERMINATED					
15.5	3.	2.	4.	0.0	0.0	0.0
18.0	12.	5.	9.	2.	1.	0.0
21.5	24.	15.	15.	12.	2.	2.
25.5	41.	31.	30.	27.	15.	8.
30.0	77.	60.	59.	48.	45.	32.
32.0	95.	77.	86.	64.	56.	56.
36.0	121.	110.	114.	112.	105.	87.
40.0	124.	124.	124.	120.	118.	119.
44.5	124.	124.	124.	121.	125.	122.

MEAN TIME FOR 50 PERCENT OF SEEDS TO GERMINATE	27.2	29.3	28.9	30.1	31.7	32.6
STANDARD DEVIATION	58.0	59.0	59.0	53.0	50.0	45.0

EXPERIMENT NO.	621.	622.	623.	624.	625.	626.
PLATE VOLTAGE	2000.	2000.	2000.	2000.	2000.	0.0
EXPOSURE TIME (SEC.)	20.	15.	10.	5.	1.	0.0
SOYBEANS - NO PRETREATMENT					A.C.	FIELD

TIME (HOURS)	NUMBER OF SEEDS GERMINATED					
19.0	2.	3.	4.	9.	4.	0.0
23.0	3.	10.	15.	15.	13.	6.
25.5	12.	16.	25.	28.	18.	13.
30.0	40.	43.	67.	71.	48.	47.
33.0	73.	71.	81.	103.	82.	68.
37.0	113.	109.	112.	122.	113.	107.
41.0	120.	119.	125.	123.	120.	119.
45.0	123.	123.	125.	125.	125.	125.

MEAN TIME FOR 50 PERCENT OF SEEDS TO GERMINATE	31.6	31.4	29.9	28.7	30.8	32.0
STANDARD DEVIATION	45.0	54.0	56.0	52.0	55.0	51.0

EXPERIMENT NO.	631.	632.	633.	634.	635.	636.
PLATE VOLTAGE	1500.	1500.	1500.	1500.	1500.	0.0
EXPOSURE TIME (SEC.)	20.	15.	10.	5.	1.	0.0
SOYBEANS - NO PRETREATMENT					A.C.	FIELD

TIME (HOURS)	NUMBER OF SEEDS GERMINATED					
17.5	0.0	0.0	0.0	0.0	0.0	0.0
20.0	1.	0.0	0.0	0.0	0.0	0.0
24.5	6.	6.	4.	6.	5.	4.
27.5	16.	12.	9.	12.	10.	9.
31.5	50.	27.	23.	44.	37.	45.
35.5	86.	57.	56.	73.	77.	79.
39.5	113.	97.	91.	104.	103.	104.
42.5	118.	119.	119.	118.	124.	122.
46.0	122.	123.	124.	125.	125.	124.

MEAN TIME FOR 50 PERCENT OF SEEDS TO GERMINATE	32.8	35.1	35.7	34.0	34.1	33.8
STANDARD DEVIATION	49.0	52.0	49.0	54.0	48.0	48.0

EXPERIMENT NO.	641.	642.	643.	644.	645.	646.
PLATE VOLTAGE	1000.	1000.	1000.	1000.	1000.	0.0
EXPOSURE TIME (SEC.)	20.	15.	10.	5.	1.	0.0
SOYBEANS - NO PRETREATMENT					A.C.	FIELD

TIME (HOURS)	NUMBER OF SEEDS GERMINATED					
18.0	1.	0.0	1.	1.	0.0	1.
22.0	8.	4.	12.	9.	0.0	3.
26.0	13.	15.	38.	31.	25.	18.
29.0	30.	38.	60.	55.	55.	42.
32.0	49.	57.	77.	77.	72.	57.
37.0	96.	99.	116.	118.	114.	97.
40.5	121.	119.	123.	125.	125.	114.
47.0	124.	125.	126.	125.	128.	125.

MEAN TIME FOR 50 PERCENT OF SEEDS TO GERMINATE	32.5	32.3	29.5	29.7	30.7	32.3
STANDARD DEVIATION	54.0	53.0	56.0	50.0	48.0	59.0

EXPERIMENT NO.	651.	652.	653.	654.	655.	656.
PLATE VOLTAGE	500.	500.	500.	500.	500.	0.0
EXPOSURE TIME (SEC.)	20.	15.	10.	5.	1.	0.0
SOYBEANS - NO PRETREATMENT					A.C.	FIELD

TIME (HOURS)	NUMBER OF SEEDS GERMINATED					
16.0	0.0	0.0	0.0	2.	0.0	0.0
20.0	2.	0.0	0.0	2.	0.0	0.0
24.0	7.	2.	0.0	3.	0.0	3.
27.0	15.	4.	1.	6.	1.	7.
30.0	27.	14.	2.	13.	14.	18.
35.0	53.	40.	41.	43.	38.	46.
38.5	89.	69.	75.	79.	71.	69.
45.0	122.	120.	122.	123.	120.	117.
48.0	124.	124.	124.	123.	125.	122.

MEAN TIME FOR 50 PERCENT OF SEEDS TO GERMINATE	34.8	37.0	37.2	36.1	37.2	36.5
STANDARD DEVIATION	60.0	52.0	39.0	54.0	48.0	56.0

EXPERIMENT NO.	661.	662.	663.	664.	665.	666.
PLATE VOLTAGE	0.0	0.0	0.0	0.0	0.0	0.0
EXPOSURE TIME (SEC.)	0.0	0.0	0.0	0.0	0.0	0.0
SOYBEANS - NO PRETREATMENT					A.C.	FIELD

TIME (HOURS)	NUMBER OF SEEDS GERMINATED					
19.0	0.0	0.0	2.	1.	1.	0.0
21.5	0.0	0.0	2.	1.	3.	1.
25.0	0.0	2.	3.	2.	6.	3.
27.5	4.	4.	7.	6.	11.	6.
31.0	8.	15.	19.	18.	26.	15.
34.5	29.	37.	32.	31.	50.	35.
38.5	55.	64.	58.	59.	77.	62.
40.5	83.	85.	92.	84.	95.	86.
45.0	106.	108.	115.	107.	107.	102.
48.5	118.	114.	123.	119.	110.	109.
54.5	122.	122.	124.	123.	120.	122.

MEAN TIME FOR 50 PERCENT OF SEEDS TO GERMINATE	38.6	37.9	37.4	38.0	36.2	38.3
STANDARD DEVIATION	54.0	61.0	58.0	61.0	71.0	67.0

EXPERIMENT NO.	671.	672.	673.	674.	675.	676.
PLATE VOLTAGE	0.0	0.0	0.0	0.0	0.0	0.0
EXPOSURE TIME (SEC.)	0.0	0.0	0.0	0.0	0.0	0.0
SOYBEANS - NO PRETREATMENT					A.C.	FIELD

TIME (HOURS)	NUMBER OF SEEDS GERMINATED					
18.5	1.	0.0	0.0	0.0	0.0	1.
21.0	1.	0.0	0.0	0.0	0.0	2.
24.5	1.	0.0	1.	3.	3.	8.
27.0	3.	3.	1.	10.	7.	13.
30.5	7.	6.	5.	15.	15.	19.
34.0	27.	28.	17.	35.	33.	35.
38.0	52.	56.	39.	57.	57.	63.
40.0	78.	80.	67.	83.	85.	88.
44.5	101.	105.	96.	108.	114.	109.
48.0	113.	122.	112.	123.	118.	118.
54.0	123.	125.	125.	124.	124.	125.

MEAN TIME FOR 50 PERCENT OF SEEDS TO GERMINATE	38.8	38.5	40.3	37.5	37.5	37.1
STANDARD DEVIATION	61.0	53.0	57.0	60.0	59.0	70.0

EXPERIMENT NO.	681.	682.	683.	684.	685.	686.
PLATE VOLTAGE	0.0	0.0	0.0	0.0	0.0	0.0
EXPOSURE TIME (SEC.)	0.0	0.0	0.0	0.0	0.0	0.0
SOYBEANS - NO PRETREATMENT					A.C.	FIELD

TIME (HOURS)	NUMBER OF SEEDS GERMINATED					
22.0	2.	0.0	0.0	1.	0.0	1.
26.0	4.	0.0	0.0	1.	0.0	1.
30.5	7.	0.0	2.	4.	9.	2.
35.5	19.	11.	11.	13.	31.	24.
40.0	41.	35.	42.	46.	60.	53.
44.0	81.	69.	82.	70.	92.	92.
47.5	99.	100.	112.	99.	102.	106.
52.0	114.	120.	125.	112.	117.	119.
54.5	120.	122.	128.	116.	120.	122.
63.5	122.	124.	129.	123.	125.	124.

MEAN TIME FOR 50 PERCENT OF SEEDS TO GERMINATE	41.7	43.0	42.3	42.6	40.6	40.9
STANDARD DEVIATION	69.0	52.0	51.0	67.0	70.0	60.0

EXPERIMENT NO.	691.	692.	693.	694.	695.	696.
PLATE VOLTAGE	0.0	0.0	0.0	0.0	0.0	0.0
EXPOSURE TIME (SEC.)	0.0	0.0	0.0	0.0	0.0	0.0
SOYBEANS - NO PRETREATMENT					A.C.	FIELD

TIME (HOURS)	NUMBER OF SEEDS GERMINATED					
21.5	0.0	0.0	0.0	0.0	0.0	0.0
25.5	0.0	0.0	1.	0.0	0.0	0.0
30.0	3.	1.	4.	2.	1.	3.
35.0	14.	15.	6.	9.	10.	14.
39.5	35.	27.	28.	33.	23.	33.
43.5	56.	46.	49.	51.	42.	60.
47.0	83.	74.	67.	75.	73.	93.
51.5	114.	107.	100.	104.	109.	116.
54.0	123.	115.	114.	117.	119.	122.
63.0	124.	123.	123.	123.	123.	125.

MEAN TIME FOR 50 PERCENT OF SEEDS TO GERMINATE	43.4	44.6	45.2	44.4	45.0	43.1
STANDARD DEVIATION	62.0	67.0	69.0	66.0	60.0	60.0

EXPERIMENT NO.	1201.	1202.	1203.	1204.	1205.	1206.
PLATE VOLTAGE	5500.	4000.	3000.	2000.	500.	0.0
EXPOSURE TIME (SEC.)	20.	20.	20.	20.	20.	0.0
SOYBEANS - NO PRETREATMENT					A.C.	FIELD

TIME (HOURS)	NUMBER OF SEEDS GERMINATED					
16.5	0.0	0.0	1.	1.	0.0	0.0
21.5	27.	15.	21.	42.	27.	32.
24.5	48.	42.	54.	57.	58.	62.
28.0	74.	77.	89.	89.	89.	91.
30.5	99.	96.	96.	99.	101.	107.
36.0	109.	104.	112.	116.	112.	108.
40.5	115.	116.	116.	120.	118.	116.
49.0	121.	123.	122.	122.	123.	122.
52.5	123.	123.	123.	123.	123.	123.

MEAN TIME FOR 50 PERCENT OF SEEDS TO GERMINATE	27.1	27.7	26.6	25.4	26.0	26.0
STANDARD DEVIATION	69.0	63.0	65.0	63.0	60.0	68.0

EXPERIMENT NO.	1211.	1212.	1213.	1214.	1215.	1216.
PLATE VOLTAGE	5500.	4000.	3000.	2000.	500.	0.0
EXPOSURE TIME (SEC.)	10.	10.	10.	10.	10.	0.0
SOYBEANS - NO PRETREATMENT					A.C.	FIELD

TIME (HOURS)	NUMBER OF SEEDS GERMINATED					
16.0	0.0	1.	3.	4.	0.0	0.0
21.0	13.	30.	30.	48.	16.	25.
24.0	29.	56.	50.	71.	42.	57.
27.5	64.	88.	80.	93.	84.	83.
30.0	75.	93.	92.	99.	99.	92.
35.5	102.	108.	107.	108.	117.	105.
40.0	110.	115.	117.	112.	121.	111.
48.5	116.	119.	120.	119.	122.	118.
52.0	121.	120.	123.	120.	122.	123.

MEAN TIME FOR 50 PERCENT OF SEEDS TO GERMINATE	29.0	25.6	26.5	24.3	26.0	27.0
STANDARD DEVIATION	74.0	67.0	75.0	74.0	47.0	81.0



EXPERIMENT NO.	1221.	1222.	1223.	1224.	1225.	1226.
PLATE VOLTAGE	5500.	4000.	3000.	2000.	500.	0.0
EXPOSURE TIME (SEC.)	1.	1.	1.	1.	1.	0.0
SUYBEANS - NO PRETREATMENT					A.C.	FIELD

TIME (HOURS)	NUMBER OF SEEDS GERMINATED					
15.5	0.0	1.	0.0	1.	0.0	0.0
20.5	4.	7.	12.	26.	12.	29.
23.5	24.	30.	38.	48.	38.	57.
27.5	59.	79.	80.	78.	71.	84.
29.5	84.	96.	99.	96.	87.	99.
35.0	102.	108.	115.	111.	109.	112.
39.5	111.	115.	119.	115.	117.	114.
48.0	119.	120.	123.	118.	123.	116.
51.5	119.	122.	123.	118.	124.	118.

MEAN TIME FOR 50 PERCENT OF SEEDS TO GERMINATE	28.2	27.1	26.2	25.3	27.3	24.9
STANDARD DEVIATION	57.0	61.0	51.0	57.0	63.0	62.0

EXPERIMENT NO.	1091.	1092.	1093.	1094.	1095.	1096.
PLATE VOLTAGE	3500.	3000.	2000.	1000.	500.	0.0
EXPOSURE TIME (SEC.)	10.	10.	10.	10.	10.	0.0
CORN - NO PRETREATMENT					D.C.	FIELD

TIME (HOURS)	NUMBER OF SEEDS GERMINATED					
17.0	0.0	0.0	0.0	0.0	0.0	0.0
21.0	1.	2.	1.	1.	1.	1.
24.5	1.	3.	1.	4.	6.	7.
27.5	1.	4.	3.	11.	15.	13.
30.0	11.	11.	11.	21.	30.	32.
35.0	38.	44.	36.	57.	59.	62.
40.0	65.	76.	78.	98.	95.	98.
46.0	107.	102.	112.	124.	117.	116.
51.0	120.	115.	121.	125.	120.	120.
64.0	124.	123.	123.	126.	121.	123.

MEAN TIME FOR 50 PERCENT OF SEEDS TO GERMINATE	39.0	38.5	38.1	35.5	34.9	34.9
STANDARD DEVIATION	65.0	74.0	59.0	57.0	63.0	67.0

EXPERIMENT NO.	1101.	1102.	1103.	1104.	1105.	1106.
PLATE VOLTAGE	3500.	3000.	2000.	1000.	500.	0.0
EXPOSURE TIME (SEC.)	1.	1.	1.	1.	1.	0.0
CORN - NO PRETREATMENT					D.C.	FIELD

TIME (HOURS)	NUMBER OF SEEDS GERMINATED					
16.5	0.0	0.0	0.0	0.0	0.0	0.0
20.5	0.0	1.	2.	0.0	1.	1.
24.0	3.	4.	5.	7.	7.	7.
27.0	18.	10.	11.	17.	25.	13.
29.5	28.	34.	26.	33.	36.	31.
34.5	67.	63.	69.	66.	88.	71.
39.5	111.	102.	99.	103.	112.	112.
45.0	120.	119.	118.	121.	121.	122.
50.5	121.	121.	121.	122.	121.	124.

MEAN TIME FOR 50 PERCENT OF SEEDS TO GERMINATE	33.2	33.8	33.9	33.4	31.8	33.2
STANDARD DEVIATION	50.0	55.0	57.0	56.0	50.0	53.0

EXPERIMENT NO.	1111.	1112.	1113.	1114.	1115.	1116.
PLATE VOLTAGE	3500.	3000.	2000.	1000.	500.	0.0
EXPOSURE TIME (SEC.)	20.	20.	20.	20.	20.	0.0
CORN - NO PRETREATMENT					D.C.	FIELD

TIME (HOURS)	NUMBER OF SEEDS GERMINATED					
21.5	0.0	0.0	0.0	1.	0.0	0.0
27.0	3.	6.	5.	10.	6.	12.
30.0	24.	20.	11.	21.	14.	25.
33.5	39.	30.	29.	48.	27.	49.
36.5	54.	54.	49.	71.	54.	70.
42.0	88.	100.	85.	112.	99.	107.
46.5	113.	118.	109.	120.	117.	120.
52.5	123.	120.	120.	123.	123.	121.

MEAN TIME FOR 50 PERCENT OF SEEDS TO GERMINATE	37.3	36.6	38.1	35.1	37.3	35.0
STANDARD DEVIATION	65.0	55.0	62.0	56.0	56.0	57.0

EXPERIMENT NO.	1121.	1122.	1123.	1124.	1125.	1126.
PLATE VOLTAGE	3500.	3500.	3500.	3500.	3500.	0.0
EXPOSURE TIME (SEC.)	20.	15.	10.	5.	1.	0.0
CORN - NO PRETREATMENT					D.C.	FIELD

TIME (HOURS)	NUMBER OF SEEDS GERMINATED					
21.0	2.	0.0	0.0	1.	0.0	0.0
26.5	10.	12.	12.	15.	14.	18.
29.5	32.	29.	34.	28.	39.	28.
33.0	52.	59.	62.	56.	65.	65.
36.0	90.	79.	93.	84.	84.	84.
41.5	121.	113.	120.	114.	116.	118.
46.0	124.	121.	123.	120.	122.	124.
52.0	124.	122.	125.	120.	124.	125.

MEAN TIME FOR 50 PERCENT OF SEEDS TO GERMINATE	33.1	33.6	33.0	33.1	33.0	33.1
STANDARD DEVIATION	48.0	54.0	50.0	52.0	56.0	54.0

EXPERIMENT NO.	1131.	1132.	1133.	1134.	1135.	1136.
PLATE VOLTAGE	3000.	3000.	3000.	3000.	3000.	0.0
EXPOSURE TIME (SEC.)	20.	15.	10.	5.	1.	0.0
CORN - NO PRETREATMENT					D.C.	FIELD

TIME (HOURS)	NUMBER OF SEEDS GERMINATED					
18.0	0.0	1.	0.0	1.	0.0	0.0
23.0	1.	3.	3.	4.	2.	2.
27.5	17.	15.	15.	17.	12.	21.
33.0	58.	51.	40.	43.	38.	52.
37.5	98.	80.	75.	92.	81.	89.
42.0	120.	112.	108.	110.	104.	112.
46.0	123.	120.	119.	121.	119.	122.
52.0	123.	121.	122.	124.	121.	122.
63.0	124.	122.	122.	125.	121.	122.

MEAN TIME FOR 50 PERCENT OF SEEDS TO GERMINATE	33.4	34.5	35.3	34.6	35.3	33.8
STANDARD DEVIATION	51.0	61.0	60.0	62.0	56.0	57.0

EXPERIMENT NO.	1141.	1142.	1143.	1144.	1145.	1146.
PLATE VOLTAGE	2000.	2000.	2000.	2000.	2000.	0.0
EXPOSURE TIME (SEC.)	20.	15.	10.	5.	1.	0.0
CORN - NO PRETREATMENT					D.C.	FIELD

TIME (HOURS)	NUMBER OF SEEDS GERMINATED					
18.5	1.	0.0	1.	0.0	1.	0.0
23.5	1.	0.0	1.	1.	4.	0.0
28.0	8.	4.	6.	4.	16.	6.
33.5	27.	20.	26.	35.	29.	29.
38.0	63.	53.	55.	69.	58.	72.
42.5	103.	91.	94.	96.	96.	103.
46.5	119.	118.	119.	113.	111.	118.
52.5	121.	120.	122.	120.	116.	122.
63.5	122.	122.	125.	123.	119.	123.

MEAN TIME FOR 50 PERCENT OF SEEDS TO GERMINATE	37.3	38.7	38.4	37.6	37.3	37.1
STANDARD DEVIATION	56.0	54.0	62.0	63.0	72.0	54.0

EXPERIMENT NO.	1151.	1152.	1153.	1154.	1155.	1156.
PLATE VOLTAGE	1000.	1000.	1000.	1000.	1000.	0.0
EXPOSURE TIME (SEC.)	20.	15.	10.	5.	1.	0.0
CORN - NO PRETREATMENT					D.C.	FIELD

TIME (HOURS)	NUMBER OF SEEDS GERMINATED					
17.5	0.0	0.0	0.0	0.0	0.0	0.0
24.0	0.0	0.0	0.0	0.0	0.0	0.0
27.0	1.	0.0	0.0	0.0	0.0	2.
29.5	1.	2.	1.	6.	1.	5.
34.5	18.	9.	20.	26.	20.	26.
39.5	51.	42.	46.	61.	44.	66.
44.5	92.	92.	82.	97.	92.	101.
47.5	101.	109.	97.	112.	109.	115.
54.5	121.	121.	122.	120.	123.	120.
66.5	122.	125.	123.	123.	124.	121.

MEAN TIME FOR 50 PERCENT OF						
SEEDS TO GERMINATE	41.0	41.8	41.7	39.7	41.0	39.0
STANDARD DEVIATION	59.0	55.0	62.0	62.0	56.0	55.0

EXPERIMENT NO.	1161.	1162.	1163.	1164.	1165.	1166.
PLATE VOLTAGE	500.	500.	500.	500.	500.	0.0
EXPOSURE TIME (SEC.)	20.	15.	10.	5.	1.	0.0
CORN - NO PRETREATMENT					D.C.	FIELD

TIME (HOURS)	NUMBER OF SEEDS GERMINATED					
17.0	0.0	0.0	0.0	0.0	0.0	0.0
23.5	0.0	1.	0.0	0.0	0.0	0.0
26.5	3.	6.	6.	2.	6.	2.
29.0	11.	13.	11.	11.	19.	10.
34.0	41.	37.	34.	33.	32.	39.
39.5	87.	76.	78.	77.	88.	92.
44.0	111.	112.	105.	107.	118.	112.
47.0	116.	120.	115.	120.	122.	120.
54.0	122.	123.	119.	122.	123.	123.

MEAN TIME FOR 50 PERCENT OF						
SEEDS TO GERMINATE	36.5	36.9	37.1	37.4	36.2	36.5
STANDARD DEVIATION	56.0	58.0	58.0	55.0	53.0	52.0

EXPERIMENT NO.	701.	702.	703.	704.	705.	706.
PLATE VOLTAGE	4000.	4000.	4000.	4000.	4000.	0.0
EXPOSURE TIME (SEC.)	20.	15.	10.	5.	1.	0.0
CORN - NO PRETREATMENT					A.C.	FIELD

TIME (HOURS)	NUMBER OF SEEDS GERMINATED					
21.0	0.0	2.	1.	0.0	2.	0.0
24.0	0.0	2.	1.	0.0	2.	2.
29.0	8.	7.	12.	9.	6.	11.
34.5	43.	34.	33.	38.	32.	47.
40.0	81.	78.	75.	75.	66.	87.
43.0	104.	95.	96.	90.	93.	111.
48.0	120.	120.	114.	116.	115.	120.
52.0	121.	122.	122.	122.	121.	123.
54.5	121.	122.	123.	125.	122.	124.
59.0	121.	122.	124.	125.	123.	124.
63.5	123.	122.	125.	125.	123.	124.

MEAN TIME FOR 50 PERCENT OF SEEDS TO GERMINATE	37.4	37.8	38.4	38.5	38.8	36.5
STANDARD DEVIATION	61.0	59.0	70.0	66.0	65.0	58.0

EXPERIMENT NO.	711.	712.	713.	714.	715.	716.
PLATE VOLTAGE	3000.	3000.	3000.	3000.	3000.	0.0
EXPOSURE TIME (SEC.)	20.	15.	10.	5.	1.	0.0
CORN - NO PRETREATMENT					A.C.	FIELD

TIME (HOURS)	NUMBER OF SEEDS GERMINATED					
16.5	1.	0.0	0.0	0.0	0.0	0.0
22.0	1.	0.0	0.0	0.0	0.0	3.
25.0	1.	2.	0.0	2.	1.	4.
30.0	7.	8.	8.	5.	6.	11.
34.0	28.	27.	29.	24.	20.	29.
36.5	44.	47.	53.	40.	38.	47.
41.0	76.	74.	79.	75.	73.	77.
45.5	111.	103.	111.	115.	105.	109.
50.5	119.	113.	121.	123.	119.	120.
53.5	120.	117.	122.	125.	120.	121.
58.0	122.	117.	123.	125.	122.	123.

MEAN TIME FOR 50 PERCENT OF SEEDS TO GERMINATE	38.7	38.5	38.3	39.0	39.5	38.4
STANDARD DEVIATION	60.0	60.0	57.0	54.0	58.0	66.0

EXPERIMENT NO.	721.	722.	723.	724.	725.	726.
PLATE VOLTAGE	1000.	1000.	1000.	1000.	1000.	0.0
EXPOSURE TIME (SEC.)	20.	15.	10.	5.	1.	0.0
CORN - NO PRETREATMENT					A.C.	FIELD

TIME (HOURS)	NUMBER OF SEEDS GERMINATED					
21.0	1.	1.	1.	0.0	0.0	2.
24.5	4.	1.	1.	1.	1.	4.
28.5	8.	8.	4.	7.	9.	10.
33.5	29.	26.	16.	20.	23.	33.
38.5	58.	54.	38.	45.	47.	66.
42.5	88.	91.	79.	83.	82.	90.
48.0	110.	116.	113.	111.	111.	111.
52.0	121.	123.	117.	121.	120.	122.
54.5	121.	124.	117.	123.	121.	122.
64.0	122.	124.	118.	124.	125.	123.

MEAN TIME FOR 50 PERCENT OF SEEDS TO GERMINATE	38.5	38.8	40.0	40.0	39.9	38.0
STANDARD DEVIATION	70.0	62.0	56.0	65.0	71.0	72.0

EXPERIMENT NO.	731.	732.	733.	734.	735.	736.
PLATE VOLTAGE	2000.	2000.	2000.	2000.	2000.	0.0
EXPOSURE TIME (SEC.)	20.	15.	10.	5.	1.	0.0
CORN - NO PRETREATMENT					A.C.	FIELD

TIME (HOURS)	NUMBER OF SEEDS GERMINATED					
20.0	0.0	1.	0.0	0.0	0.0	1.
23.5	0.0	1.	6.	2.	2.	2.
27.5	7.	10.	15.	7.	11.	13.
32.5	33.	33.	35.	33.	33.	37.
37.5	75.	71.	72.	71.	69.	72.
41.5	106.	106.	106.	98.	97.	109.
47.0	119.	121.	117.	117.	114.	123.
51.0	121.	122.	122.	122.	116.	124.
53.5	122.	122.	122.	125.	116.	127.

MEAN TIME FOR 50 PERCENT OF SEEDS TO GERMINATE	35.9	35.7	35.5	36.8	35.7	35.8
STANDARD DEVIATION	53.0	54.0	62.0	63.0	58.0	62.0

EXPERIMENT NO.	741.	742.	743.	744.	745.	746.
PLATE VOLTAGE	5000.	5000.	5000.	5000.	5000.	0.0
EXPOSURE TIME (SEC.)	20.	15.	10.	5.	1.	0.0
CORN - NO PRETREATMENT					A.C.	FIELD

TIME (HOURS)	NUMBER OF SEEDS GERMINATED					
22.0	0.0	2.	1.	0.0	1.	2.
25.0	1.	4.	2.	3.	2.	3.
29.0	9.	10.	6.	10.	10.	11.
34.0	27.	30.	19.	20.	27.	25.
39.0	58.	56.	47.	45.	60.	50.
43.5	93.	76.	80.	83.	88.	90.
46.0	109.	93.	100.	103.	103.	98.
50.0	115.	111.	113.	115.	118.	112.
53.0	120.	118.	121.	121.	123.	121.
55.5	120.	121.	122.	122.	124.	123.

MEAN TIME FOR 50 PERCENT OF SEEDS TO GERMINATE	38.7	39.7	40.5	40.1	39.2	39.8
STANDARD DEVIATION	61.0	77.0	65.0	65.0	67.0	72.0

EXPERIMENT NO.	751.	752.	753.	754.	755.	756.
PLATE VOLTAGE	500.	500.	500.	500.	500.	0.0
EXPOSURE TIME (SEC.)	20.	15.	10.	5.	1.	0.0
CORN - NO PRETREATMENT					A.C.	FIELD

TIME (HOURS)	NUMBER OF SEEDS GERMINATED					
21.0	0.0	0.0	1.	0.0	0.0	0.0
24.0	2.	3.	3.	1.	2.	2.
28.0	7.	6.	7.	6.	5.	10.
33.0	26.	28.	25.	31.	29.	36.
38.0	62.	66.	58.	62.	60.	62.
42.5	98.	100.	96.	102.	96.	102.
45.0	113.	110.	110.	109.	110.	111.
49.0	118.	121.	122.	123.	122.	118.
52.0	121.	125.	124.	124.	124.	119.

MEAN TIME FOR 50 PERCENT OF SEEDS TO GERMINATE	37.5	37.5	37.9	37.5	37.9	36.6
STANDARD DEVIATION	57.0	60.0	60.0	57.0	59.0	59.0



EXPERIMENT NO.	761.	762.	763.	764.	765.	766.
PLATE VOLTAGE	5500.	5500.	5500.	5500.	5500.	C.C
EXPOSURE TIME (SEC.)	20.	15.	10.	5.	1.	C.C
CORN - NO PRETREATMENT					A.C.	FIELD

TIME (HOURS)	NUMBER OF SEEDS GERMINATED					
21.0	0.0	0.0	0.0	0.0	0.0	0.0
25.0	1.	3.	4.	1.	7.	2.
29.5	9.	11.	11.	16.	15.	22.
33.0	24.	22.	28.	34.	34.	31.
37.0	46.	42.	50.	57.	63.	55.
41.0	68.	76.	77.	86.	85.	81.
45.5	105.	100.	101.	115.	109.	100.
50.0	115.	120.	117.	120.	120.	114.
53.0	121.	123.	121.	123.	122.	122.
57.5	122.	124.	122.	123.	123.	123.

MEAN TIME FOR 50 PERCENT OF SEEDS TO GERMINATE	39.1	39.2	38.5	37.2	37.1	38.0
STANDARD DEVIATION	64.0	66.0	68.0	61.0	68.0	75.0

EXPERIMENT NO.	771.	772.	773.	774.	775.	776.
PLATE VOLTAGE	4500.	4500.	4500.	4500.	4500.	C.C
EXPOSURE TIME (SEC.)	20.	15.	10.	5.	1.	C.C
CORN - NO PRETREATMENT					A.C.	FIELD

TIME (HOURS)	NUMBER OF SEEDS GERMINATED					
20.5	0.0	0.0	0.0	1.	0.0	0.0
24.5	2.	1.	2.	5.	2.	1.
29.0	13.	13.	13.	14.	11.	14.
32.5	39.	34.	31.	37.	34.	38.
36.5	64.	63.	60.	67.	60.	65.
40.5	96.	93.	101.	103.	82.	99.
45.0	112.	112.	117.	118.	111.	116.
49.5	118.	121.	124.	122.	118.	122.
52.5	120.	121.	124.	122.	120.	123.
57.0	120.	123.	124.	122.	120.	123.

MEAN TIME FOR 50 PERCENT OF SEEDS TO GERMINATE	35.9	36.5	36.2	35.3	36.7	35.9
STANDARD DEVIATION	58.0	60.0	54.0	55.0	61.0	56.0

EXPERIMENT NO.	781.	782.	783.	784.	785.	786.
PLATE VOLTAGE	3500.	3500.	3500.	3500.	3500.	0.0
EXPOSURE TIME (SEC.)	20.	15.	10.	5.	1.	0.0
CORN - NO PRETREATMENT					A.C.	FIELD

TIME (HOURS)	NUMBER OF SEEDS GERMINATED					
22.5	0.0	0.0	1.	0.0	0.0	2.
27.0	3.	2.	2.	2.	4.	7.
32.0	25.	16.	12.	12.	14.	23.
35.0	35.	27.	25.	24.	18.	39.
39.5	64.	58.	58.	47.	40.	74.
43.5	87.	89.	80.	70.	73.	101.
45.0	100.	107.	95.	81.	89.	105.
49.0	112.	116.	110.	110.	109.	114.
53.5	119.	120.	119.	121.	121.	122.
57.0	119.	121.	122.	123.	123.	123.

MEAN TIME FOR 50 PERCENT OF SEEDS TO GERMINATE	38.6	39.3	40.3	41.4	41.4	37.9
STANDARD DEVIATION	65.0	57.0	66.0	66.0	66.0	69.0

EXPERIMENT NO.	791.	792.	793.	794.	795.	796.
PLATE VOLTAGE	2500.	2500.	2500.	2500.	2500.	0.0
EXPOSURE TIME (SEC.)	20.	15.	10.	5.	1.	0.0
CORN - NO PRETREATMENT					A.C.	FIELD

TIME (HOURS)	NUMBER OF SEEDS GERMINATED					
21.5	0.0	1.	2.	0.0	0.0	0.0
26.0	4.	1.	6.	7.	10.	2.
31.0	22.	13.	27.	21.	15.	25.
34.0	43.	35.	51.	48.	37.	45.
38.5	72.	62.	79.	76.	68.	76.
42.5	103.	98.	99.	103.	99.	103.
44.0	115.	109.	110.	111.	113.	113.
48.0	128.	120.	121.	117.	119.	122.
52.5	128.	124.	123.	120.	123.	124.
56.0	128.	124.	124.	122.	123.	124.

MEAN TIME FOR 50 PERCENT OF SEEDS TO GERMINATE	36.9	37.9	36.1	36.4	37.0	36.5
STANDARD DEVIATION	57.0	55.0	66.0	63.0	61.0	57.0

EXPERIMENT NO.	801.	802.	803.	804.	805.	806.
PLATE VOLTAGE	1500.	1500.	1500.	1500.	1500.	0.0
EXPOSURE TIME (SEC.)	20.	15.	10.	5.	1.	0.0
CORN - NO PRETREATMENT					A.C.	FIELD

TIME (HOURS)	NUMBER OF SEEDS GERMINATED					
24.0	1.	0.0	1.	4.	1.	0.0
25.5	4.	3.	1.	4.	1.	5.
30.5	11.	12.	10.	7.	13.	16.
35.0	33.	28.	29.	24.	31.	39.
39.0	62.	55.	52.	45.	55.	71.
44.0	96.	95.	87.	92.	85.	106.
47.5	108.	119.	110.	110.	99.	115.
52.5	116.	123.	121.	120.	120.	123.
63.5	122.	123.	123.	122.	121.	123.

MEAN TIME FOR 50 PERCENT OF SEEDS TO GERMINATE	39.2	39.1	40.0	40.0	39.9	37.7
STANDARD DEVIATION	70.0	57.0	64.0	63.0	70.0	61.0

EXPERIMENT NO.	811.	812.	813.	814.	815.	816.
PLATE VOLTAGE	5500.	4000.	3000.	2000.	500.	0.0
EXPOSURE TIME (SEC.)	1.	1.	1.	1.	1.	0.0
CORN - NO PRETREATMENT					A.C.	FIELD

TIME (HOURS)	NUMBER OF SEEDS GERMINATED					
23.5	1.	1.	0.0	1.	1.	3.
25.0	3.	2.	1.	2.	2.	3.
30.0	20.	12.	18.	16.	14.	28.
34.5	43.	43.	35.	44.	53.	56.
38.5	87.	79.	73.	83.	88.	86.
43.5	117.	108.	111.	112.	118.	110.
47.0	123.	118.	121.	118.	124.	121.
52.0	123.	121.	123.	122.	125.	123.
63.0	123.	122.	124.	122.	125.	123.

MEAN TIME FOR 50 PERCENT OF SEEDS TO GERMINATE	35.7	36.7	37.0	36.2	35.7	35.3
STANDARD DEVIATION	50.0	55.0	55.0	54.0	49.0	61.0

EXPERIMENT NO.	821.	822.	823.	824.	825.	826.
PLATE VOLTAGE	5500.	4000.	3000.	2000.	500.	0.0
EXPOSURE TIME (SEC.)	20.	20.	20.	20.	20.	0.0
CORN - NO PRETREATMENT					A.C.	FIELD

TIME (HOURS)	NUMBER OF SEEDS GERMINATED					
17.0	0.0	0.0	0.0	0.0	0.0	0.0
21.0	1.	0.0	1.	0.0	0.0	1.
27.0	2.	3.	4.	4.	2.	6.
29.5	11.	9.	9.	6.	4.	9.
34.0	31.	27.	29.	15.	23.	32.
39.0	54.	55.	51.	47.	53.	67.
42.0	76.	82.	72.	68.	82.	87.
47.0	103.	108.	104.	113.	111.	108.
51.5	119.	122.	122.	120.	119.	117.
53.5	121.	123.	124.	122.	123.	120.
64.5	123.	125.	124.	123.	124.	123.

MEAN TIME FOR 50 PERCENT OF SEEDS TO GERMINATE	39.6	39.6	39.8	40.4	39.7	38.6
STANDARD DEVIATION	70.0	65.0	68.0	58.0	60.0	70.0

EXPERIMENT NO.	831.	832.	833.	834.	835.	836.
PLATE VOLTAGE	5500.	4000.	3000.	2000.	500.	0.0
EXPOSURE TIME (SEC.)	10.	10.	10.	10.	10.	0.0
CORN - NO PRETREATMENT					A.C.	FIELD

TIME (HOURS)	NUMBER OF SEEDS GERMINATED					
16.0	0.0	0.0	0.0	0.0	0.0	0.0
20.0	0.0	0.0	1.	0.0	0.0	0.0
26.0	2.	1.	5.	5.	2.	1.
28.5	9.	5.	13.	13.	3.	7.
33.0	31.	25.	30.	36.	25.	31.
38.0	66.	58.	60.	71.	61.	62.
41.0	89.	83.	81.	93.	91.	87.
46.0	116.	116.	116.	115.	112.	111.
50.5	123.	121.	120.	123.	121.	121.
52.5	124.	121.	122.	123.	121.	121.
63.5	124.	122.	123.	123.	123.	123.

MEAN TIME FOR 50 PERCENT OF SEEDS TO GERMINATE	37.3	38.0	37.6	36.5	38.0	37.3
STANDARD DEVIATION	58.0	55.0	66.0	61.0	57.0	61.0

EXPERIMENT NO.	1001.	1002.	1003.	1004.	1005.	1006.
PLATE VOLTAGE	3500.	3500.	3500.	3500.	3500.	0.0
EXPOSURE TIME (SEC.)	20.	15.	10.	5.	1.	0.0
SOYBEANS - PRESOAKED 6 HOURS IN TAP WATER					D.C.	FIELD

TIME (HOURS)	NUMBER OF SEEDS GERMINATED					
6.5	0.0	0.0	2.	1.	0.0	4.
9.0	36.	24.	35.	33.	54.	45.
11.5	75.	72.	70.	70.	89.	77.
15.0	103.	101.	98.	105.	108.	97.
19.0	111.	113.	107.	113.	113.	108.
24.0	115.	119.	115.	118.	119.	112.
43.0	119.	122.	121.	122.	124.	124.

MEAN TIME FOR 50 PERCENT OF SEEDS TO GERMINATE	10.7	11.4	11.0	10.9	10.1	11.0
STANDARD DEVIATION	1.3	1.2	1.5	1.3	1.4	1.7

EXPERIMENT NO.	1011.	1012.	1013.	1014.	1015.	1016.
PLATE VOLTAGE	3000.	3000.	3000.	3000.	3000.	0.0
EXPOSURE TIME (SEC.)	20.	15.	10.	5.	1.	0.0
SOYBEANS - PRESOAKED 6 HOURS IN TAP WATER					D.C.	FIELD

TIME (HOURS)	NUMBER OF SEEDS GERMINATED					
5.5	1.	0.0	0.0	0.0	1.	2.
8.0	30.	25.	23.	18.	33.	39.
10.5	77.	69.	73.	63.	73.	80.
14.0	102.	96.	100.	94.	92.	106.
18.0	111.	106.	109.	111.	106.	115.
23.0	115.	109.	115.	113.	115.	116.
42.0	123.	118.	118.	123.	121.	119.

MEAN TIME FOR 50 PERCENT OF SEEDS TO GERMINATE	9.9	10.3	10.1	11.1	10.3	9.2
STANDARD DEVIATION	1.6	1.6	1.3	1.4	1.6	1.4

EXPERIMENT NO.	1021.	1022.	1023.	1024.	1025.	1026.
PLATE VOLTAGE	2000.	2000.	2000.	2000.	2000.	0.0
EXPOSURE TIME (SEC.)	20.	15.	10.	5.	1.	0.0
SOYBEANS - PRESOAKED 6 HOURS IN TAP WATER					D.C.	FIELD

TIME (HOURS)	NUMBER OF SEEDS GERMINATED					
6.5	0.0	0.0	0.0	0.0	0.0	0.0
9.5	40.	35.	19.	27.	36.	49.
12.0	89.	86.	63.	65.	77.	85.
15.0	105.	98.	94.	87.	91.	101.
21.0	118.	108.	112.	107.	100.	109.
30.5	122.	118.	114.	119.	111.	114.
41.0	126.	118.	116.	122.	113.	116.

MEAN TIME FOR 50 PERCENT OF SEEDS TO GERMINATE	11.0	11.0	12.0	12.2	11.2	10.5
STANDARD DEVIATION	1.4	1.2	1.1	1.4	1.5	1.3

EXPERIMENT NO.	1031.	1032.	1033.	1034.	1035.	1036.
PLATE VOLTAGE	1000.	1000.	1000.	1000.	1000.	0.0
EXPOSURE TIME (SEC.)	20.	15.	10.	5.	1.	0.0
SOYBEANS - PRESOAKED 6 HOURS IN TAP WATER					D.C.	FIELD

TIME (HOURS)	NUMBER OF SEEDS GERMINATED					
5.0	0.0	0.0	0.0	0.0	0.0	0.0
8.5	27.	22.	29.	37.	23.	46.
11.0	77.	68.	76.	72.	74.	96.
14.0	97.	89.	90.	88.	94.	110.
20.0	116.	107.	108.	102.	107.	118.
29.5	122.	114.	117.	113.	114.	122.
40.0	124.	115.	118.	118.	116.	122.

MEAN TIME FOR 50 PERCENT OF SEEDS TO GERMINATE	10.7	10.9	10.7	10.6	10.7	9.2
STANDARD DEVIATION	1.4	1.3	1.4	1.8	1.3	1.2

EXPERIMENT NO.	1041.	1042.	1043.	1044.	1045.	1046.
PLATE VOLTAGE	3500.	3000.	2000.	1000.	500.	0.0
EXPOSURE TIME (SEC.)	20.	20.	20.	20.	20.	0.0
SOYBEANS - PRESOAKED 6 HOURS IN TAP WATER					D.C.	FIELD

TIME (HOURS)	NUMBER OF SEEDS GERMINATED					
6.0	0.0	0.0	0.0	0.0	0.0	0.0
10.0	47.	41.	64.	46.	43.	52.
12.5	76.	82.	89.	83.	70.	71.
14.5	93.	99.	98.	100.	92.	86.
19.0	104.	108.	109.	109.	100.	97.
24.0	113.	115.	114.	114.	111.	108.
40.0	117.	121.	120.	119.	118.	114.

MEAN TIME FOR 50 PERCENT OF SEEDS TO GERMINATE	11.2	11.3	10.2	11.0	11.6	11.1
STANDARD DEVIATION	1.4	1.3	1.5	1.3	1.4	1.6

EXPERIMENT NO.	1051.	1052.	1053.	1054.	1055.	1056.
PLATE VOLTAGE	500.	500.	500.	500.	500.	0.0
EXPOSURE TIME (SEC.)	20.	15.	10.	5.	1.	0.0
SOYBEANS - PRESOAKED 6 HOURS IN TAP WATER					D.C.	FIELD

TIME (HOURS)	NUMBER OF SEEDS GERMINATED					
5.0	0.0	0.0	0.0	0.0	0.0	0.0
9.0	50.	39.	36.	37.	26.	50.
11.5	81.	66.	68.	69.	57.	88.
13.5	96.	74.	80.	87.	71.	98.
18.0	103.	92.	99.	99.	95.	105.
23.0	110.	106.	111.	110.	112.	115.
39.0	118.	117.	121.	118.	120.	119.

MEAN TIME FOR 50 PERCENT OF SEEDS TO GERMINATE	9.9	11.3	11.2	10.8	12.1	9.9
STANDARD DEVIATION	1.7	1.9	1.7	1.7	1.6	1.5

EXPERIMENT NO.	1061.	1062.	1063.	1064.	1065.	1066.
PLATE VOLTAGE	3500.	3000.	2000.	1000.	500.	0.0
EXPOSURE TIME (SEC.)	10.	10.	10.	10.	10.	0.0
SOYBEANS - PRESOAKED 6 HOURS IN TAP WATER					D.C.	FIELD

TIME (HOURS)	NUMBER OF SEEDS GERMINATED					
7.0	0.0	0.0	4.	0.0	0.0	1.
8.0	2.	7.	9.	9.	3.	9.
9.5	31.	30.	47.	33.	34.	42.
12.5	76.	76.	96.	86.	82.	79.
15.0	97.	97.	111.	101.	104.	100.
18.0	107.	103.	114.	107.	106.	107.
25.0	119.	110.	118.	114.	114.	118.
44.5	120.	119.	122.	118.	120.	123.

MEAN TIME FOR 50 PERCENT OF SEEDS TO GERMINATE	11.6	11.9	10.6	11.2	11.5	11.4
STANDARD DEVIATION	1.0	1.4	1.2	1.2	1.2	1.3

EXPERIMENT NO.	1071.	1072.	1073.	1074.	1075.	1076.
PLATE VOLTAGE	3500.	3000.	2000.	1000.	500.	0.0
EXPOSURE TIME (SEC.)	1.	1.	1.	1.	1.	0.0
SOYBEANS - PRESOAKED 6 HOURS IN TAP WATER					D.C.	FIELD

TIME (HOURS)	NUMBER OF SEEDS GERMINATED					
6.5	0.0	0.0	0.0	0.0	1.	0.0
7.5	4.	6.	6.	8.	7.	5.
9.0	35.	44.	29.	39.	44.	47.
12.0	88.	77.	75.	79.	85.	90.
14.5	101.	97.	90.	96.	100.	96.
17.5	104.	101.	94.	99.	108.	100.
24.5	111.	114.	105.	112.	115.	112.
44.0	119.	122.	117.	118.	120.	116.

MEAN TIME FOR 50 PERCENT OF SEEDS TO GERMINATE	10.8	11.2	11.6	11.1	10.6	10.5
STANDARD DEVIATION	1.4	1.5	1.5	1.5	1.3	1.4



EXPERIMENT NO.	1471.	1472.	1473.	1474.	1475.	1476.
PLATE VOLTAGE	3500.	3000.	2000.	1000.	500.	0.0
EXPOSURE TIME (SEC.)	40.	40.	40.	40.	40.	0.0
SOYBEANS - PRESOAKED 6 HOURS IN TAP WATER					D.C.	FIELD

TIME (HOURS)	NUMBER OF SEEDS GERMINATED					
4.5	0.0	0.0	0.0	0.0	0.0	0.0
7.5	7.	12.	19.	11.	20.	32.
12.0	44.	59.	77.	73.	69.	91.
16.5	77.	81.	91.	90.	86.	107.
22.5	97.	101.	110.	106.	101.	119.
30.0	110.	111.	119.	116.	117.	121.
45.0	116.	119.	119.	121.	121.	123.

MEAN TIME FOR 50 PERCENT OF SEEDS TO GERMINATE	13.6	12.7	10.9	11.7	11.6	9.6
STANDARD DEVIATION	1.6	1.9	1.7	1.7	1.9	1.7

EXPERIMENT NO.	841.	842.	843.	844.	845.	846.
PLATE VOLTAGE	5500.	5500.	5500.	5500.	5500.	0.0
EXPOSURE TIME (SEC.)	20.	15.	10.	5.	1.	0.0
SOYBEANS - PRESOAKED 6 HOURS IN TAP WATER					A.C.	FIELD

TIME (HOURS)	NUMBER OF SEEDS GERMINATED					
7.0	7.	6.	7.	9.	12.	13.
11.5	57.	69.	73.	69.	72.	77.
13.5	83.	87.	95.	87.	88.	92.
16.0	98.	98.	103.	91.	96.	99.
18.5	103.	105.	108.	105.	100.	104.
22.5	107.	111.	112.	110.	107.	111.
24.5	109.	112.	115.	113.	107.	112.
35.0	110.	117.	118.	118.	114.	119.
42.0	113.	118.	121.	118.	116.	120.

MEAN TIME FOR 50 PERCENT OF SEEDS TO GERMINATE	11.3	11.1	10.9	11.0	10.6	10.4
STANDARD DEVIATION	1.5	1.5	1.5	1.6	1.8	1.7

EXPERIMENT NO.	851.	852.	853.	854.	855.	856.
PLATE VOLTAGE	5000.	5000.	5000.	5000.	5000.	0.0
EXPOSURE TIME (SEC.)	20.	15.	10.	5.	1.	0.0
SOYBEANS - PRESOAKED 6 HOURS IN TAP WATER					A.C.	FIELD

TIME (HOURS)	NUMBER OF SEEDS GERMINATED					
6.5	1.	3.	3.	1.	2.	4.
11.0	77.	63.	52.	49.	43.	50.
13.0	90.	80.	70.	69.	71.	66.
15.5	100.	89.	89.	75.	85.	77.
18.0	104.	100.	91.	89.	91.	87.
22.0	112.	108.	102.	100.	101.	98.
24.0	117.	114.	107.	107.	104.	103.
34.5	119.	118.	118.	117.	116.	115.
41.5	120.	119.	118.	118.	116.	117.

MEAN TIME FOR 50 PERCENT OF SEEDS TO GERMINATE	10.5	11.2	12.3	12.6	12.4	12.5
STANDARD DEVIATION	1.5	1.6	1.6	1.7	1.5	1.8

EXPERIMENT NO.	861.	862.	863.	864.	865.	866.
PLATE VOLTAGE	4500.	4500.	4500.	4500.	4500.	0.0
EXPOSURE TIME (SEC.)	20.	15.	10.	5.	1.	0.0
SOYBEANS - PRESOAKED 6 HOURS IN TAP WATER					A.C.	FIELD

TIME (HOURS)	NUMBER OF SEEDS GERMINATED					
6.0	0.0	0.0	0.0	0.0	0.0	0.0
9.0	37.	42.	38.	45.	40.	44.
11.0	77.	71.	72.	75.	74.	74.
15.5	103.	99.	105.	98.	102.	98.
19.0	109.	109.	115.	107.	113.	107.
22.0	111.	113.	121.	108.	115.	113.
24.0	114.	113.	122.	111.	117.	114.
35.0	118.	119.	124.	114.	121.	121.

MEAN TIME FOR 50 PERCENT OF SEEDS TO GERMINATE	10.4	10.6	10.6	10.2	10.6	10.7
STANDARD DEVIATION	1.3	1.5	1.3	1.4	1.4	1.5

EXPERIMENT NO.	871.	872.	873.	874.	875.	876.
PLATE VOLTAGE	4000.	4000.	4000.	4000.	4000.	0.0
EXPOSURE TIME (SEC.)	20.	15.	10.	5.	1.	0.0
SOYBEANS - PRESOAKED 6 HOURS IN TAP WATER					A.C.	FIELD

TIME (HOURS)	NUMBER OF SEEDS GERMINATED					
5.0	0.0	0.0	0.0	0.0	0.0	0.0
8.0	40.	34.	19.	19.	24.	10.
10.0	58.	48.	42.	44.	48.	38.
14.5	96.	78.	75.	84.	88.	83.
18.0	106.	86.	86.	90.	94.	91.
21.0	116.	95.	103.	104.	105.	105.
23.0	116.	95.	105.	104.	108.	108.
34.0	119.	112.	120.	119.	124.	122.
45.0	120.	114.	122.	120.	125.	122.

MEAN TIME FOR 50 PERCENT OF SEEDS TO GERMINATE	10.0	11.2	12.4	12.0	11.8	12.4
STANDARD DEVIATION	1.7	2.1	1.8	1.8	1.8	1.6

EXPERIMENT NO.	881.	882.	883.	884.	885.	886.
PLATE VOLTAGE	3500.	3500.	3500.	3500.	3500.	0.0
EXPOSURE TIME (SEC.)	20.	15.	10.	5.	1.	0.0
SOYBEANS - PRESOAKED 6 HOURS IN TAP WATER					A.C.	FIELD

TIME (HOURS)	NUMBER OF SEEDS GERMINATED					
6.5	0.0	0.0	0.0	0.0	1.	0.0
9.5	30.	22.	31.	33.	35.	44.
12.0	73.	65.	68.	66.	68.	81.
15.0	92.	89.	94.	89.	86.	102.
19.0	105.	102.	105.	104.	101.	108.
24.0	119.	114.	110.	110.	115.	115.
32.0	122.	123.	116.	118.	122.	123.
45.0	122.	124.	116.	118.	124.	123.

MEAN TIME FOR 50 PERCENT OF SEEDS TO GERMINATE	11.8	12.6	11.6	11.9	12.2	11.0
STANDARD DEVIATION	1.3	1.4	1.3	1.4	1.5	1.4

EXPERIMENT NO.	891.	892.	893.	894.	895.	896.
PLATE VOLTAGE	3000.	3000.	3000.	3000.	3000.	0.0
EXPOSURE TIME (SEC.)	20.	15.	10.	5.	1.	0.0
SOYBEANS - PRESOAKED 6 HOURS IN TAP WATER					A.C.	FIELD

TIME (HOURS)	NUMBER OF SEEDS GERMINATED					
5.5	0.0	0.0	0.0	0.0	0.0	1.
8.5	27.	20.	24.	23.	25.	31.
11.0	80.	70.	73.	77.	72.	84.
14.0	101.	95.	90.	94.	87.	99.
18.0	108.	103.	101.	115.	96.	104.
23.0	113.	111.	106.	116.	104.	110.
31.0	119.	120.	122.	125.	116.	116.
44.0	119.	120.	122.	125.	121.	118.

MEAN TIME FOR 50 PERCENT OF SEEDS TO GERMINATE	10.3	11.0	11.2	10.8	11.4	10.2
STANDARD DEVIATION	1.3	1.4	1.6	1.4	1.8	1.5

EXPERIMENT NO.	901.	902.	903.	904.	905.	906.
PLATE VOLTAGE	2500.	2500.	2500.	2500.	2500.	0.0
EXPOSURE TIME (SEC.)	20.	15.	10.	5.	1.	0.0
SOYBEANS - PRESOAKED 6 HOURS IN TAP WATER					A.C.	FIELD

TIME (HOURS)	NUMBER OF SEEDS GERMINATED					
6.5	0.0	0.0	0.0	0.0	0.0	0.0
7.5	2.	2.	1.	3.	0.0	0.0
10.0	35.	30.	17.	29.	30.	37.
12.5	71.	75.	60.	76.	71.	64.
14.5	90.	102.	86.	95.	93.	91.
19.5	106.	118.	108.	108.	106.	102.
27.5	118.	119.	120.	120.	118.	118.
30.5	118.	121.	121.	122.	118.	121.
40.5	121.	121.	123.	124.	118.	122.
47.0	121.	121.	123.	124.	119.	122.

MEAN TIME FOR 50 PERCENT OF SEEDS TO GERMINATE	12.1	11.8	12.9	12.1	12.1	12.4
STANDARD DEVIATION	1.3	0.9	1.2	1.3	1.2	1.3

EXPERIMENT NO.	911.	912.	913.	914.	915.	916.
PLATE VOLTAGE	2000.	2000.	2000.	2000.	2000.	0.0
EXPOSURE TIME (SEC.)	20.	15.	10.	5.	1.	0.0
SOYBEANS - PRESOAKED 6 HOURS IN TAP WATER					A.C.	FIELD

TIME (HOURS)	NUMBER OF SEEDS GERMINATED					
5.5	0.0	0.0	0.0	0.0	0.0	0.0
6.5	1.	1.	2.	3.	0.0	1.
9.0	34.	38.	36.	26.	26.	35.
11.5	74.	83.	82.	74.	77.	88.
13.5	89.	91.	95.	84.	87.	95.
18.5	101.	109.	112.	95.	104.	109.
26.5	111.	120.	119.	109.	114.	121.
29.5	114.	121.	119.	110.	116.	122.
39.5	120.	122.	122.	116.	119.	123.
46.0	122.	122.	122.	118.	119.	123.

MEAN TIME FOR 50 PERCENT OF SEEDS TO GERMINATE	11.6	10.7	10.6	11.8	11.4	10.6
STANDARD DEVIATION	1.7	1.4	1.3	1.6	1.4	1.3

EXPERIMENT NO.	921.	922.	923.	924.	925.	926.
PLATE VOLTAGE	1500.	1500.	1500.	1500.	1500.	0.0
EXPOSURE TIME (SEC.)	20.	15.	10.	5.	1.	0.0
SOYBEANS - PRESOAKED 6 HOURS IN TAP WATER					A.C.	FIELD

TIME (HOURS)	NUMBER OF SEEDS GERMINATED					
6.5	0.0	0.0	0.0	2.	0.0	0.0
9.0	32.	29.	38.	32.	36.	34.
11.5	73.	68.	67.	82.	74.	69.
14.5	93.	95.	89.	101.	91.	88.
17.0	105.	106.	101.	108.	96.	96.
21.5	108.	112.	107.	116.	104.	103.
27.0	113.	114.	114.	120.	115.	113.
40.5	114.	119.	116.	122.	122.	120.

MEAN TIME FOR 50 PERCENT OF SEEDS TO GERMINATE	10.8	11.3	11.1	10.8	11.6	11.7
STANDARD DEVIATION	1.3	1.4	1.4	1.3	1.7	1.6

EXPERIMENT NO.	931.	932.	933.	934.	935.	936.
PLATE VOLTAGE	1000.	1000.	1000.	1000.	1000.	0.0
EXPOSURE TIME (SEC.)	20.	15.	10.	5.	1.	0.0
SOYBEANS - PRESOAKED 6 HOURS IN TAP WATER					A.C.	FIELD

TIME (HOURS)	NUMBER OF SEEDS GERMINATED					
5.5	0.0	1.	0.0	0.0	0.0	0.0
8.5	25.	23.	33.	28.	27.	49.
12.5	72.	61.	68.	61.	62.	84.
13.5	93.	90.	83.	76.	76.	101.
16.0	102.	100.	89.	91.	92.	102.
20.5	106.	105.	98.	102.	102.	108.
26.0	115.	115.	112.	109.	111.	116.
39.5	118.	119.	118.	119.	118.	120.

MEAN TIME FOR 50 PERCENT OF SEEDS TO GERMINATE	10.6	11.0	10.9	11.3	11.4	9.5
STANDARD DEVIATION	1.4	1.5	1.8	1.8	1.7	1.7

EXPERIMENT NO.	941.	942.	943.	944.	945.	946.
PLATE VOLTAGE	1000.	1000.	1000.	1000.	1000.	0.0
EXPOSURE TIME (SEC.)	20.	15.	10.	5.	1.	0.0
SOYBEANS - PRESOAKED 6 HOURS IN TAP WATER					A.C.	FIELD

TIME (HOURS)	NUMBER OF SEEDS GERMINATED					
7.0	1.	0.0	1.	0.0	1.	2.
9.5	25.	23.	28.	25.	35.	31.
12.0	72.	77.	72.	69.	73.	64.
15.0	98.	106.	93.	97.	96.	87.
17.5	103.	108.	104.	106.	103.	99.
25.0	111.	115.	113.	116.	118.	115.
41.0	119.	120.	123.	120.	123.	122.

MEAN TIME FOR 50 PERCENT OF SEEDS TO GERMINATE	11.9	11.6	12.2	11.9	11.8	12.3
STANDARD DEVIATION	1.2	1.1	1.4	1.2	1.4	1.5

EXPERIMENT NO.	951.	952.	953.	954.	955.	956.
PLATE VOLTAGE	500.	500.	500.	500.	500.	0.0
EXPOSURE TIME (SEC.)	20.	15.	10.	5.	1.	0.0
SOYBEANS - PRESOAKED 6 HOURS IN TAP WATER					A.C.	FIELD

TIME (HOURS)	NUMBER OF SEEDS GERMINATED					
6.0	0.0	0.0	0.0	0.0	0.0	0.0
8.5	25.	19.	16.	27.	24.	25.
11.0	75.	72.	71.	61.	61.	77.
14.0	101.	98.	94.	88.	85.	101.
16.5	111.	104.	101.	98.	95.	110.
24.0	116.	113.	113.	108.	114.	114.
40.0	122.	121.	122.	117.	124.	117.

MEAN TIME FOR 50 PERCENT OF SEEDS TO GERMINATE	10.6	11.0	11.3	11.2	11.7	10.2
STANDARD DEVIATION	1.3	1.4	1.4	1.6	1.6	1.2

EXPERIMENT NO.	961.	962.	963.	964.	965.	966.
PLATE VOLTAGE	1500.	1500.	1500.	1500.	1500.	0.0
EXPOSURE TIME (SEC.)	20.	15.	10.	5.	1.	0.0
SOYBEANS - PRESOAKED 6 HOURS IN TAP WATER					A.C.	FIELD

TIME (HOURS)	NUMBER OF SEEDS GERMINATED					
6.5	0.0	1.	0.0	0.0	0.0	1.
9.0	26.	28.	28.	17.	18.	34.
11.5	77.	70.	73.	70.	66.	85.
14.5	98.	95.	92.	95.	88.	101.
18.0	107.	107.	100.	108.	98.	106.
24.0	115.	119.	110.	112.	103.	116.
29.0	117.	120.	115.	117.	112.	119.
40.0	119.	124.	120.	124.	112.	122.

MEAN TIME FOR 50 PERCENT OF SEEDS TO GERMINATE	11.1	11.5	11.6	12.0	11.6	10.9
STANDARD DEVIATION	1.3	1.4	1.5	1.4	1.3	1.4

EXPERIMENT NO.	971.	972.	973.	974.	975.	976.
PLATE VOLTAGE	5500.	4000.	3000.	2000.	500.	0.0
EXPOSURE TIME (SEC.)	10.	10.	10.	10.	10.	0.0
SOYBEANS - PRESOAKED 6 HOURS IN TAP WATER					A.C.	FIELD

TIME (HOURS)	NUMBER OF SEEDS GERMINATED					
5.5	1.	0.0	1.	0.0	0.0	0.0
8.0	35.	31.	37.	30.	23.	35.
10.5	62.	69.	69.	54.	58.	79.
13.5	85.	87.	87.	78.	87.	98.
17.0	95.	96.	94.	93.	96.	105.
23.0	109.	105.	110.	108.	109.	113.
28.0	118.	115.	120.	115.	116.	121.
39.0	122.	119.	123.	121.	121.	121.

MEAN TIME FOR 50 PERCENT OF SEEDS TO GERMINATE	10.8	10.6	10.6	11.3	11.1	9.9
STANDARD DEVIATION	1.8	1.8	1.9	1.8	1.7	1.5

EXPERIMENT NO.	981.	982.	983.	984.	985.	986.
PLATE VOLTAGE	5500.	4000.	3000.	2000.	500.	0.0
EXPOSURE TIME (SEC.)	20.	20.	20.	20.	20.	0.0
SOYBEANS - PRESOAKED 6 HOURS IN TAP WATER					A.C.	FIELD

TIME (HOURS)	NUMBER OF SEEDS GERMINATED					
7.0	0.0	2.	2.	2.	5.	0.0
9.5	23.	41.	29.	33.	37.	32.
12.5	74.	83.	74.	79.	71.	68.
14.5	91.	96.	94.	99.	88.	85.
16.0	98.	99.	101.	101.	99.	92.
21.0	110.	111.	111.	112.	110.	104.
24.0	114.	116.	114.	115.	119.	112.
29.0	119.	117.	119.	118.	120.	114.
40.5	120.	119.	121.	122.	123.	117.

MEAN TIME FOR 50 PERCENT OF SEEDS TO GERMINATE	12.0	11.2	11.7	11.6	11.6	11.9
STANDARD DEVIATION	1.2	1.3	1.3	1.4	1.5	1.4



EXPERIMENT NO.	991.	992.	993.	994.	995.	996.
PLATE VOLTAGE	5500.	4000.	3000.	2000.	500.	0.0
EXPOSURE TIME (SEC.)	1.	1.	1.	1.	1.	0.0
SOYBEANS - PRESOAKED 6 HOURS IN TAP WATER					A.C.	FIELD

TIME (HOURS)	NUMBER OF SEEDS GERMINATED					
6.0	0.0	0.0	0.0	1.	0.0	0.0
8.5	13.	19.	17.	17.	29.	39.
11.5	58.	52.	66.	61.	76.	91.
13.5	74.	73.	77.	76.	91.	101.
15.0	84.	84.	92.	82.	97.	106.
20.0	104.	99.	107.	98.	110.	115.
23.0	111.	101.	112.	103.	115.	116.
28.0	113.	109.	121.	109.	119.	122.
39.5	120.	117.	123.	117.	119.	122.

MEAN TIME FOR 50 PERCENT OF SEEDS TO GERMINATE	12.4	12.4	11.9	12.2	10.8	9.7
STANDARD DEVIATION	1.5	1.6	1.4	1.6	1.3	1.3

EXPERIMENT NO.	1081.	1082.	1083.	1084.	1085.	1086.
PLATE VOLTAGE	5500.	4000.	3000.	500.	0.0	0.0
EXPOSURE TIME (SEC.)	40.	40.	40.	40.	0.0	0.0
SOYBEANS - PRESOAKED 6 HOURS IN TAP WATER					A.C.	FIELD

TIME (HOURS)	NUMBER OF SEEDS GERMINATED					
6.0	0.0	0.0	0.0	0.0	0.0	0.0
8.0	8.	12.	12.	9.	5.	0.0
10.0	33.	50.	50.	42.	24.	0.0
11.0	55.	75.	64.	65.	36.	0.0
13.5	82.	108.	87.	88.	67.	0.0
18.0	98.	115.	102.	103.	84.	0.0
37.0	115.	121.	120.	117.	108.	0.0

MEAN TIME FOR 50 PERCENT OF SEEDS TO GERMINATE	11.7	10.4	11.4	11.2	12.8	0.0
STANDARD DEVIATION	1.3	1.0	1.4	1.2	1.3	0.0

EXPERIMENT NO.	1461.	1462.	1463.	1464.	1465.	1466.
PLATE VOLTAGE	5500.	4000.	3000.	2000.	500.	0.0
EXPOSURE TIME (SEC.)	40.	40.	40.	40.	40.	0.0
SOYBEANS - PRESOAKED 6 HOURS IN TAP WATER					A.C.	FIELD

TIME (HOURS)	NUMBER OF SEEDS GERMINATED					
6.0	0.0	0.0	0.0	0.0	0.0	0.0
9.0	12.	20.	10.	14.	21.	14.
13.0	64.	63.	57.	57.	65.	60.
18.0	86.	83.	76.	87.	86.	87.
24.0	107.	101.	107.	104.	101.	106.
31.0	115.	112.	115.	112.	110.	115.
46.5	120.	118.	119.	120.	117.	120.

MEAN TIME FOR 50 PERCENT OF SEEDS TO GERMINATE	13.7	13.5	14.2	14.0	12.9	13.7
STANDARD DEVIATION	1.5	1.7	1.5	1.6	1.7	1.5

EXPERIMENT NO.	1371.	1372.	1373.	1374.	1375.	1376.
PLATE VOLTAGE	3500.	3500.	3500.	3500.	3500.	0.0
EXPOSURE TIME (SEC.)	20.	15.	10.	5.	1.	0.0
CORN - PRESOAKED 6 HOURS	IN TAP WATER				D.C. FIELD	

TIME (HOURS)	NUMBER OF SEEDS GERMINATED					
5.5	0.0	0.0	0.0	0.0	0.0	0.0
8.5	5.	1.	2.	1.	0.0	4.
13.5	23.	21.	25.	29.	22.	31.
17.5	74.	65.	61.	71.	71.	80.
20.0	90.	85.	97.	96.	96.	105.
23.5	103.	108.	108.	112.	105.	114.
30.5	105.	109.	113.	115.	107.	118.
44.0	108.	109.	113.	115.	111.	119.

MEAN TIME FOR 50 PERCENT OF SEEDS TO GERMINATE	15.7	16.3	16.2	15.9	16.2	15.4
STANDARD DEVIATION	2.9	2.2	2.4	2.3	2.4	2.7

EXPERIMENT NO.	1381.	1382.	1383.	1384.	1385.	1386.
PLATE VOLTAGE	3000.	3000.	3000.	3000.	3000.	0.0
EXPOSURE TIME (SEC.)	20.	15.	10.	5.	1.	0.0
CORN - PRESOAKED 6 HOURS	IN TAP WATER				D.C. FIELD	

TIME (HOURS)	NUMBER OF SEEDS GERMINATED					
4.0	0.0	0.0	0.0	0.0	0.0	0.0
7.5	15.	17.	10.	10.	13.	5.
10.0	27.	26.	23.	31.	27.	13.
14.0	68.	72.	62.	73.	69.	70.
20.0	104.	103.	103.	101.	103.	106.
23.5	113.	117.	114.	111.	113.	114.
29.0	119.	121.	117.	115.	117.	117.
46.0	122.	122.	117.	117.	120.	122.

MEAN TIME FOR 50 PERCENT OF SEEDS TO GERMINATE	13.0	12.8	13.2	12.7	13.1	13.8
STANDARD DEVIATION	4.2	4.1	3.5	3.8	4.0	3.3

EXPERIMENT NO.	1391.	1392.	1393.	1394.	1395.	1396.
PLATE VOLTAGE	2000.	2000.	2000.	2000.	2000.	0.0
EXPOSURE TIME (SEC.)	20.	15.	10.	5.	1.	0.0
CORN - PRESOAKED 6 HOURS	IN TAP WATER				D.C. FIELD	

TIME (HOURS)	NUMBER OF SEEDS GERMINATED					
4.0	0.0	0.0	0.0	0.0	0.0	0.0
7.0	19.	7.	12.	19.	16.	15.
9.0	32.	22.	32.	32.	32.	23.
14.5	70.	72.	74.	71.	57.	66.
19.0	101.	105.	99.	101.	98.	94.
22.5	112.	112.	110.	110.	113.	102.
28.0	117.	117.	115.	114.	117.	108.
45.0	118.	119.	121.	118.	119.	113.

MEAN TIME FOR 50 PERCENT OF SEEDS TO GERMINATE	12.0	12.8	12.5	12.0	12.7	12.8
STANDARD DEVIATION	4.4	3.7	4.5	4.6	4.5	4.5

EXPERIMENT NO.	1401.	1402.	1403.	1404.	1405.	1406.
PLATE VOLTAGE	1000.	1000.	1000.	1000.	1000.	0.0
EXPOSURE TIME (SEC.)	20.	15.	10.	5.	1.	0.0
CORN - PRESOAKED 6 HOURS	IN TAP WATER				D.C. FIELD	

TIME (HOURS)	NUMBER OF SEEDS GERMINATED					
3.0	0.0	0.0	0.0	0.0	0.0	0.0
6.0	10.	10.	15.	10.	21.	12.
8.5	20.	29.	27.	25.	34.	26.
13.5	60.	75.	64.	67.	68.	70.
18.0	92.	109.	104.	96.	110.	101.
21.5	108.	117.	114.	110.	118.	112.
27.0	113.	119.	120.	112.	122.	119.
44.0	115.	122.	121.	116.	124.	123.

MEAN TIME FOR 50 PERCENT OF SEEDS TO GERMINATE	12.4	11.4	11.8	11.9	11.1	12.0
STANDARD DEVIATION	4.3	4.2	4.6	4.4	4.9	4.7

EXPERIMENT NO.	1411.	1412.	1413.	1414.	1415.	1416.
PLATE VOLTAGE	500.	500.	500.	500.	500.	0.0
EXPOSURE TIME (SEC.)	20.	15.	10.	5.	1.	0.0
CORN - PRESOAKED 6 HOURS IN TAP WATER					D.C.	FIELD

TIME (HOURS)	NUMBER OF SEEDS GERMINATED					
4.0	0.0	0.0	0.0	0.0	0.0	0.0
6.0	2.	7.	6.	1.	4.	5.
11.0	29.	35.	35.	23.	27.	22.
15.0	63.	62.	75.	74.	77.	75.
19.5	100.	100.	112.	106.	104.	99.
24.0	110.	118.	117.	118.	115.	110.
34.0	116.	122.	122.	123.	119.	119.
48.0	116.	122.	123.	123.	120.	120.

MEAN TIME FOR 50 PERCENT OF SEEDS TO GERMINATE	13.8	13.5	12.9	14.0	13.4	13.9
STANDARD DEVIATION	3.5	4.1	3.8	3.0	3.6	3.8

EXPERIMENT NO.	1421.	1422.	1423.	1424.	1425.	1426.
PLATE VOLTAGE	3500.	3000.	2000.	1000.	500.	0.0
EXPOSURE TIME (SEC.)	10.	10.	10.	10.	10.	0.0
CORN - PRESOAKED 6 HOURS IN TAP WATER					D.C.	FIELD

TIME (HOURS)	NUMBER OF SEEDS GERMINATED					
3.0	0.0	0.0	0.0	0.0	0.0	0.0
5.0	0.0	1.	5.	4.	6.	3.
10.0	25.	30.	33.	33.	34.	31.
14.5	73.	79.	82.	77.	83.	69.
18.5	99.	103.	104.	107.	106.	99.
23.0	113.	113.	117.	114.	115.	117.
33.0	119.	119.	122.	120.	118.	122.
47.0	121.	122.	122.	122.	122.	123.

MEAN TIME FOR 50 PERCENT OF SEEDS TO GERMINATE	13.4	12.8	12.1	12.5	12.0	13.0
STANDARD DEVIATION	3.6	4.0	4.0	4.3	4.5	4.1

EXPERIMENT NO.	1431.	1432.	1433.	1434.	1435.	1436.
PLATE VOLTAGE	3500.	3000.	2000.	1000.	500.	0.0
EXPOSURE TIME (SEC.)	1.	1.	1.	1.	1.	0.0
CORN - PRESOAKED 6 HOURS	IN TAP WATER				D.C. FIELD	

TIME (HOURS)	NUMBER OF SEEDS GERMINATED					
2.5	0.0	0.0	0.0	0.0	0.0	0.0
5.0	5.	8.	6.	4.	8.	6.
9.5	31.	31.	30.	24.	23.	34.
14.0	81.	75.	80.	64.	62.	75.
18.0	99.	99.	101.	90.	93.	100.
23.5	114.	115.	118.	109.	113.	120.
32.5	120.	118.	123.	115.	120.	122.
46.5	122.	122.	125.	118.	122.	123.

MEAN TIME FOR 50 PERCENT OF SEEDS TO GERMINATE	12.0	12.1	12.2	13.2	13.1	11.9
STANDARD DEVIATION	4.5	4.9	4.5	4.4	4.7	4.5

EXPERIMENT NO.	1441.	1442.	1443.	1444.	1445.	1446.
PLATE VOLTAGE	3500.	3000.	2000.	1000.	500.	0.0
EXPOSURE TIME (SEC.)	20.	20.	20.	20.	20.	0.0
CORN - PRESOAKED 6 HOURS	IN TAP WATER				D.C. FIELD	

TIME (HOURS)	NUMBER OF SEEDS GERMINATED					
5.0	0.0	2.	1.	3.	3.	2.
8.0	7.	22.	12.	13.	15.	10.
12.0	24.	51.	45.	41.	47.	40.
17.0	89.	98.	82.	87.	91.	101.
19.5	108.	111.	107.	101.	104.	110.
26.5	120.	121.	119.	116.	119.	121.
42.5	123.	123.	122.	119.	121.	122.

MEAN TIME FOR 50 PERCENT OF SEEDS TO GERMINATE	14.4	12.2	13.4	13.2	12.8	13.0
STANDARD DEVIATION	2.9	4.0	3.8	4.0	4.0	3.3

EXPERIMENT NO.	1231.	1232.	1233.	1234.	1235.	1236.
PLATE VOLTAGE	5500.	5500.	5500.	5500.	5500.	0.0
EXPOSURE TIME (SEC.)	20.	15.	10.	5.	1.	0.0
CORN - PRESOAKED 6 HOURS	IN TAP WATER				A.C. FIELD	

TIME (HOURS)	NUMBER OF SEEDS GERMINATED					
6.0	0.0	0.0	0.0	0.0	0.0	0.0
11.0	1.	11.	9.	9.	11.	9.
16.0	38.	47.	55.	59.	60.	57.
20.0	86.	97.	88.	101.	94.	87.
24.5	98.	115.	106.	112.	110.	104.
28.0	99.	117.	106.	113.	112.	109.
41.5	107.	122.	108.	114.	113.	112.
44.0	107.	122.	108.	114.	113.	112.

MEAN TIME FOR 50 PERCENT OF SEEDS TO GERMINATE	17.3	16.6	15.8	15.5	15.5	16.1
STANDARD DEVIATION	2.4	2.7	2.5	2.3	2.6	2.8

EXPERIMENT NO.	1241.	1242.	1243.	1244.	1245.	1246.
PLATE VOLTAGE	5000.	5000.	5000.	5000.	5000.	0.0
EXPOSURE TIME (SEC.)	20.	15.	10.	5.	1.	0.0
CORN - PRESOAKED 6 HOURS	IN TAP WATER				A.C. FIELD	

TIME (HOURS)	NUMBER OF SEEDS GERMINATED					
5.0	0.0	0.0	0.0	0.0	0.0	0.0
10.0	7.	9.	8.	9.	8.	7.
15.0	60.	62.	50.	62.	61.	55.
19.0	101.	107.	100.	100.	88.	86.
23.5	114.	118.	111.	109.	104.	97.
27.0	114.	118.	112.	110.	109.	102.
40.5	115.	121.	114.	110.	113.	106.
43.0	115.	121.	114.	110.	113.	106.

MEAN TIME FOR 50 PERCENT OF SEEDS TO GERMINATE	14.7	14.6	15.0	14.1	15.0	15.1
STANDARD DEVIATION	2.3	2.6	2.5	2.3	3.0	2.9

EXPERIMENT NO.	1251.	1252.	1253.	1254.	1255.	1256.
PLATE VOLTAGE	4500.	4500.	4500.	4500.	4500.	0.0
EXPOSURE TIME (SEC.)	20.	15.	10.	5.	1.	0.0
CORN - PRESOAKED 6 HOURS	IN TAP WATER				A.C. FIELD	

TIME (HOURS)	NUMBER OF SEEDS GERMINATED					
4.0	0.0	0.0	0.0	0.0	0.0	0.0
9.0	4.	5.	7.	6.	6.	17.
14.5	49.	54.	55.	57.	57.	71.
18.0	90.	90.	99.	97.	105.	107.
22.5	108.	113.	113.	112.	118.	117.
26.0	111.	114.	115.	112.	118.	118.
39.5	111.	115.	116.	112.	120.	120.
45.0	111.	115.	116.	113.	120.	120.

MEAN TIME FOR 50 PERCENT OF SEEDS TO GERMINATE	14.6	14.5	14.1	14.1	14.2	12.9
STANDARD DEVIATION	2.4	2.5	2.5	2.6	2.5	3.1

EXPERIMENT NO.	1261.	1262.	1263.	1264.	1265.	1266.
PLATE VOLTAGE	4000.	4000.	4000.	4000.	4000.	0.0
EXPOSURE TIME (SEC.)	20.	15.	10.	5.	1.	0.0
CORN - PRESOAKED 6 HOURS	IN TAP WATER				A.C. FIELD	

TIME (HOURS)	NUMBER OF SEEDS GERMINATED					
6.0	0.0	0.0	0.0	0.0	0.0	0.0
9.0	5.	1.	0.0	1.	0.0	0.0
12.0	13.	10.	24.	15.	22.	22.
16.0	60.	71.	64.	81.	69.	69.
20.0	90.	109.	103.	103.	98.	98.
23.5	104.	116.	109.	110.	107.	104.
31.5	111.	117.	113.	115.	113.	105.
45.5	113.	118.	113.	115.	114.	105.

MEAN TIME FOR 50 PERCENT OF SEEDS TO GERMINATE	15.9	15.4	15.1	14.9	15.2	14.5
STANDARD DEVIATION	2.9	2.0	2.4	2.2	2.6	2.1



EXPERIMENT NO.	1271.	1272.	1273.	1274.	1275.	1276.
PLATE VOLTAGE	3500.	3500.	3500.	3500.	3500.	0.0
EXPOSURE TIME (SEC.)	20.	15.	10.	5.	1.	0.0
CORN - PRESOAKED 6 HOURS	IN TAP WATER				A.C. FIELD	

TIME (HOURS)	NUMBER OF SEEDS GERMINATED					
5.0	0.0	0.0	0.0	0.0	0.0	0.0
11.0	19.	22.	18.	29.	21.	21.
15.5	61.	65.	65.	63.	61.	71.
19.0	95.	101.	97.	90.	95.	99.
22.5	108.	111.	108.	100.	108.	105.
30.5	112.	113.	110.	104.	115.	109.
44.5	115.	118.	111.	104.	115.	109.

MEAN TIME FOR 50 PERCENT OF SEEDS TO GERMINATE	14.8	14.5	14.3	13.6	14.6	13.9
STANDARD DEVIATION	3.0	3.3	2.6	3.1	2.9	2.6

EXPERIMENT NO.	1281.	1282.	1283.	1284.	1285.	1286.
PLATE VOLTAGE	3000.	3000.	3000.	3000.	3000.	0.0
EXPOSURE TIME (SEC.)	20.	15.	10.	5.	1.	0.0
CORN - PRESOAKED 6 HOURS	IN TAP WATER				A.C. FIELD	

TIME (HOURS)	NUMBER OF SEEDS GERMINATED					
4.0	0.0	0.0	0.0	0.0	0.0	0.0
10.5	12.	26.	16.	18.	28.	17.
14.5	72.	71.	58.	62.	80.	67.
18.0	96.	104.	100.	94.	104.	102.
21.5	107.	116.	111.	97.	108.	108.
29.5	109.	119.	115.	102.	112.	113.
43.5	110.	120.	115.	105.	112.	114.

MEAN TIME FOR 50 PERCENT OF SEEDS TO GERMINATE	13.6	13.3	14.0	13.6	12.5	13.7
STANDARD DEVIATION	2.4	2.9	2.4	3.1	2.7	2.6

EXPERIMENT NO.	1291.	1292.	1293.	1294.	1295.	1296.
PLATE VOLTAGE	2500.	2500.	2500.	2500.	2500.	0.0
EXPOSURE TIME (SEC.)	20.	15.	10.	5.	1.	0.0
CORN - PRESOAKED 6 HOURS	IN TAP WATER				A.C. FIELD	

TIME (HOURS)	NUMBER OF SEEDS GERMINATED					
8.0	0.0	0.0	0.0	0.0	0.0	0.0
10.0	1.	2.	2.	1.	1.	2.
14.5	11.	22.	19.	18.	11.	26.
19.5	80.	80.	75.	73.	71.	79.
23.0	104.	113.	104.	104.	102.	105.
27.5	113.	116.	116.	117.	112.	108.
47.0	116.	119.	118.	117.	115.	112.

MEAN TIME FOR 50 PERCENT OF SEEDS TO GERMINATE	18.0	17.4	17.9	17.9	18.5	17.0
STANDARD DEVIATION	1.9	2.2	2.3	2.1	2.0	2.3

EXPERIMENT NO.	1301.	1302.	1303.	1304.	1305.	1306.
PLATE VOLTAGE	2000.	2000.	2000.	2000.	2000.	0.0
EXPOSURE TIME (SEC.)	20.	15.	10.	5.	1.	0.0
CORN - PRESOAKED 6 HOURS	IN TAP WATER				A.C. FIELD	

TIME (HOURS)	NUMBER OF SEEDS GERMINATED					
7.0	0.0	0.0	0.0	0.0	0.0	0.0
9.0	2.	5.	0.0	5.	0.0	2.
13.5	15.	18.	16.	18.	17.	15.
19.0	83.	75.	69.	79.	88.	81.
22.0	102.	96.	101.	103.	108.	100.
26.5	112.	107.	106.	111.	116.	106.
46.0	114.	109.	110.	112.	117.	106.

MEAN TIME FOR 50 PERCENT OF SEEDS TO GERMINATE	16.8	16.6	17.2	16.4	16.6	16.3
STANDARD DEVIATION	2.2	2.6	2.2	2.5	2.0	2.1

EXPERIMENT NO.	1311.	1312.	1313.	1314.	1315.	1316.
PLATE VOLTAGE	1500.	1500.	1500.	1500.	1500.	0.0
EXPOSURE TIME (SEC.)	20.	15.	10.	5.	1.	0.0
CORN - PRESOAKED 6 HOURS	IN TAP WATER				A.C. FIELD	

TIME (HOURS)	NUMBER OF SEEDS GERMINATED					
6.0	0.0	0.0	0.0	0.0	0.0	0.0
8.0	2.	2.	1.	2.	3.	0.0
12.5	10.	21.	9.	15.	16.	29.
18.0	80.	78.	74.	84.	74.	91.
21.5	100.	100.	102.	102.	96.	111.
25.5	106.	107.	105.	109.	105.	115.
45.0	110.	109.	107.	113.	107.	117.

MEAN TIME FOR 50 PERCENT OF SEEDS TO GERMINATE	16.0	15.4	16.1	15.7	15.7	14.8
STANDARD DEVIATION	2.3	2.6	2.1	2.5	2.6	2.4

EXPERIMENT NO.	1321.	1322.	1323.	1324.	1325.	1326.
PLATE VOLTAGE	1000.	1000.	1000.	1000.	1000.	0.0
EXPOSURE TIME (SEC.)	20.	15.	10.	5.	1.	0.0
CORN - PRESOAKED 6 HOURS	IN TAP WATER				A.C. FIELD	

TIME (HOURS)	NUMBER OF SEEDS GERMINATED					
6.5	0.0	0.0	0.0	2.	1.	0.0
10.0	9.	7.	6.	10.	14.	9.
13.0	41.	42.	37.	41.	45.	50.
16.5	85.	76.	79.	80.	83.	84.
21.0	108.	108.	107.	108.	111.	112.
26.0	112.	115.	112.	111.	116.	117.
39.0	114.	116.	114.	113.	118.	118.

MEAN TIME FOR 50 PERCENT OF SEEDS TO GERMINATE	14.1	14.6	14.7	14.1	14.0	14.1
STANDARD DEVIATION	2.5	2.5	2.5	2.8	2.9	2.5

EXPERIMENT NO.	1331.	1332.	1333.	1334.	1335.	1336.
PLATE VOLTAGE	500.	500.	500.	500.	500.	0.0
EXPOSURE TIME (SEC.)	20.	15.	10.	5.	1.	0.0
CORN - PRESOAKED 6 HOURS	IN TAP WATER				A.C. FIELD	

TIME (HOURS)	NUMBER OF SEEDS GERMINATED					
7.0	0.0	0.0	1.	1.	2.	2.
10.5	7.	7.	15.	9.	13.	8.
14.0	38.	50.	53.	51.	46.	45.
17.0	85.	88.	86.	81.	91.	86.
22.0	112.	112.	108.	107.	111.	110.
26.5	117.	112.	110.	113.	113.	113.
39.5	118.	113.	111.	115.	113.	115.

MEAN TIME FOR 50 PERCENT OF SEEDS TO GERMINATE	15.2	14.5	13.9	14.7	14.1	14.7
STANDARD DEVIATION	2.2	2.1	2.6	2.6	2.4	2.5

EXPERIMENT NO.	1341.	1342.	1343.	1344.	1345.	1346.
PLATE VOLTAGE	5500.	4000.	3000.	2000.	500.	0.0
EXPOSURE TIME (SEC.)	20.	20.	20.	20.	20.	0.0
CORN - PRESOAKED 6 HOURS	IN TAP WATER				A.C. FIELD	

TIME (HOURS)	NUMBER OF SEEDS GERMINATED					
8.0	0.0	0.0	1.	2.	0.0	1.
12.0	5.	14.	20.	11.	27.	17.
15.0	41.	57.	46.	45.	57.	54.
18.0	85.	85.	82.	78.	93.	81.
23.0	114.	115.	112.	108.	121.	111.
27.5	118.	118.	119.	110.	121.	113.
40.5	120.	120.	120.	113.	121.	117.

MEAN TIME FOR 50 PERCENT OF SEEDS TO GERMINATE	16.4	15.5	15.8	15.8	14.8	15.6
STANDARD DEVIATION	2.0	2.4	2.6	2.5	2.3	2.7

EXPERIMENT NO.	1351.	1352.	1353.	1354.	1355.	1356.
PLATE VOLTAGE	5500.	4000.	3000.	2000.	500.	0.0
EXPOSURE TIME (SEC.)	10.	10.	10.	10.	10.	0.0
CORN - PRESOAKED 6 HOURS	IN TAP WATER				A.C. FIELD	

TIME (HOURS)	NUMBER OF SEEDS GERMINATED					
6.5	0.0	0.0	0.0	0.0	0.0	0.0
9.5	2.	7.	1.	2.	6.	0.0
14.0	13.	22.	29.	19.	28.	16.
18.0	73.	68.	67.	74.	75.	64.
21.0	105.	95.	104.	103.	97.	87.
24.5	114.	107.	111.	111.	105.	97.
31.5	117.	110.	114.	115.	110.	100.
45.0	117.	110.	115.	120.	113.	105.

MEAN TIME FOR 50 PERCENT OF SEEDS TO GERMINATE	17.0	16.3	16.5	17.1	16.3	17.4
STANDARD DEVIATION	1.9	2.5	2.3	2.5	2.9	2.5

EXPERIMENT NO.	1361.	1362.	1363.	1364.	1365.	1366.
PLATE VOLTAGE	5500.	4000.	3000.	2000.	500.	0.0
EXPOSURE TIME (SEC.)	1.	1.	1.	1.	1.	0.0
CORN - PRESOAKED 6 HOURS	IN TAP WATER				A.C. FIELD	

TIME (HOURS)	NUMBER OF SEEDS GERMINATED					
6.0	0.0	0.0	0.0	0.0	0.0	0.0
9.0	6.	1.	3.	3.	2.	2.
13.5	36.	23.	26.	30.	26.	35.
17.5	70.	70.	67.	84.	80.	77.
20.5	84.	88.	92.	102.	88.	90.
24.0	95.	101.	105.	110.	101.	103.
31.0	102.	104.	109.	111.	105.	108.
44.5	105.	107.	109.	111.	105.	108.

MEAN TIME FOR 50 PERCENT OF SEEDS TO GERMINATE	15.5	16.3	15.9	15.1	15.5	15.2
STANDARD DEVIATION	3.4	2.6	2.6	2.3	2.5	2.6

EXPERIMENT NO.	1451.	1452.	1453.	1454.	1455.	1456.
PLATE VOLTAGE	5500.	4000.	3000.	2000.	500.	0.0
EXPOSURE TIME (SEC.)	40.	40.	40.	40.	40.	40.

CORN - PRESOAKED 6 HOURS IN TAP WATER A.C. FI

TIME (HOURS)	NUMBER OF SEEDS GERMINATED					
4.0	1.	1.	2.	1.	5.	1.
7.0	12.	9.	15.	15.	20.	10.
11.5	40.	49.	51.	60.	69.	54.
16.0	98.	92.	96.	93.	99.	99.
18.5	111.	107.	112.	109.	110.	108.
25.5	121.	118.	122.	123.	116.	117.
41.5	123.	120.	125.	123.	120.	120.

MEAN TIME FOR 50 PERCENT OF SEEDS TO GERMINATE						
SEEDS TO GERMINATE	12.3	12.1	11.8	11.5	10.4	11.7
STANDARD DEVIATION	3.7	3.8	4.2	4.0	4.7	3.8

APPENDIX B

Computer Programs

```

        DIMENSION SEEDS(15,6),TIME(15),EXPNO(15),SEE(15),TMU(6),VAR(6),
        IY(100),T(100),Y1(15),ITT(15),IT(100),Y2(15)
C      THIS PROGRAM REQUIRES THE FUNCTION QNORML(X) AND THE SUBROUTINE
C      PLOTLF WITH THE MAIN PROGRAM-----THIS PROGRAM CALCULATES THE
C      INVERSE NORMAL (QNORML) INTEGRAL AND THE LINE DETERMINED FROM THE
C      MEAN AND THE STANDARD DEVIATION WHICH ARE READ IN FROM DATA CARDS
C      PLOTS ARE PLOTTED WITH THE INVERSE NORMAL ON THE VERTICLE AXIS AND
C      TIME, LOGE TIME, OR LOGE LOGE TIME ON THE HORIZONTAL AXIS ---
C      BCTH THE RAW DATA AND THE POINTS DETERMINING THE LINE CALCULATED
C      FROM THE MEAN AND STANDARD DEVIATION ARE PLOTTED ON THE SAME
C      FULL PAGE GRAPH
        DC 80 N=1,60
        READ (1,10) I1
10     FORMAT (3X,I2)
        IF(I1) 85,85,15
15     READ (1,20) (TMU(J),J=1,6)
        READ (1,20) (VAR(K),K=1,6)
20     FORMAT (7X,F6.3,5(6X,F6.3))
        DC 18 I7=1,6
        TMU(I7)=ALOG(TMU(I7))
        TMU(I7)=ALOG(TMU(I7))
18     CONTINUE
        DC 40 L=1,I1
        READ (1,30) EXPNO(L),TIME(L),(SEEDS(L,M1),M1=1,6)
        TIME(L)=ALOG(TIME(L))
        TIME(L)=ALOG(TIME(L))
30     FORMAT (F11.2,F5.2,6F6.2)
40     CONTINUE
        EXP=0
        DC 80 M=1,6
        L2=C
        DC 60 K=1,I1

```



```

L2=L2+1
T(L2)=TIME(K)
Y1(L2)=SEEDS(K,M)/SEEDS(I1,M)
Y(L2)=QNORML(Y1(K))
IT(L2)=13
60 CONTINUE
L2=I1
DO 62 K1=1,I1
L2=L2+1
IT(L2)=11
T(L2)=TIME(K1)
Y(L2) =(1/VAR(M))*(T(K1)-TMU(M))
62 CONTINUE
NO=I1+I1
XMIN=T(1)
XMAX=T(I1)
YMIN=-2.41
YMAX=2.41
EXP=EXPNO(1)+ 0.1*M
WRITE (3,65)
65 FORMAT (1H1)
CALL PLCTLF (NO,T,Y,IT,XMIN,XMAX,YMIN,YMAX)
WRITE (3,75) EXP
75 FORMAT (25X,@EXPERIMENT NUMBER@,F5.1,@ PROBIT VS LOGELOGE TIME
1FCR RAW DATA AND CALCULATED XMU AND VAR@)
80 CONTINUE
85 CONTINUE
STOP
END

```

```

FUNCTION QNORML(X)

```

C

```

C      A FUNCTION FROM AMS 55 CHAPTER 26 TO COMPUTE THE INVERSE NORMAL
C      INTEGRAL FOR THE PROBABILITY X
C
      IF ( X .LE. 0.0 .OR. X .GE. 1.0 ) GO TO 10
      IF ( X .EQ. 0.5 ) GO TO 1
      GO TO 2
10 CONTINUE
1  QNORML=0.0
   RETURN
2  P=X
   IF ( X .GT. 0.5 ) P=1.0-X
   T=SQRT(ALOG(1.0/(P**2)))
   QNORML=T-(2.515517+.802853*T+.010328*T**2)/(1.0+1.432788*T+.189269
1*T**2+.001308*T**3)
   IF ( X .LT. 0.5 ) QNORML = -1.0 * QNORML
   RETURN
END

```

```

      SUBROUTINE PLCTLF(N,X,Y,IT,XMIN,XMAX,YMIN,YMAX)
C * * * * *
C
C THIS VERSION OMITTS ANY POINTS OUTSIDE THE SPECIFIED MAX AND MIN,
C BUT TELLS YOU HOW MANY WERE OMITTED.
C
C BY C. MESSINA,S.PEAVY,AND B.JOINER      NATIONAL BUREAU OF STANDARDS
C LAST UPDATED 1/30/67
C
C ORIGINAL DATA IS PRESERVED (THIS ROUTINE SEARCHES
C INSTEAD OF SORTING)
C DOES NOT CALL NEW PAGE
C
C * * * * *

```

```

C
C   N=NUMBER OF POINTS TO BE PLOTTED
C   X=ARRAY OF X VALUES TO BE PLOTTED
C   Y=ARRAY OF Y VALUES TO BE PLOTTED
C   IT=PLOTTING SYMBOL TO BE USED
C   PLOTTING SYMBOLS ARE FROM 1 THROUGH 40 AND IN THAT ORDER ARE---
C   1,2,3,4,5,6,7,8,9,0,*,+,9,TRIANGLE,A,B,C,D,E,F,G,H,I,J,K,L,M,N,O,
C   P,Q,R,S,T,U,V,W,X,Y,Z
C   DIMENSION X(1),Y(1),IT(1),PRINT(101),XP(6)
C   DIMENSION ITOTAL(101),TABLE(40)
C   INTEGER PRINT,TABLE
C   DATA TABLE/ @1@,@2@,@3@,@4@,@5@,@6@,@7@,@8@,@9@,@0@,@*@,@+@,
1   @.@,@ @,@A@,@B@,@C@,@D@,@E@,@F@,@G@,@H@,@I@,@J@,@K@,@L@,@M@,
2   @N@,@O@,@P@,@Q@,@R@,@S@,@T@,@U@,@V@,@W@,@X@,@Y@,@Z@/

```

```

C
C   IC = NUMBER OF PRINT TAPE
C   IC=3

```

```

C
C   WRITE (10,100)
100 FORMAT(14X,101H+-----+-----+-----+-----+-----+
1-----+-----+-----+-----+-----+ )
C   YDELTA=(YMAX-YMIN)/50.
C   XDELTA=(XMAX-XMIN)/100.
C   YL=YMAX-YDELTA/2.
C   YT=YMAX+YDELTA/2.
C   YLOW=YMIN-YDELTA/2.
C   XL=XMIN-XDELTA/2.
C   XHIGH=XMAX+XDELTA/2.
C   IGOUT=0
C   DO 110 I=1,N
C   IF (Y(I)-YT)101,101,109
101 IF (Y(I)-YLOW)109,109,102
102 IF (X(I)-XL)109,103,103

```

```

103 IF (X(I)-XHIGH)110,109,109
109 ICUT=ICUT+1
110 CONTINUE
    DC 350 I=1,6
    L=1
    DC 350 J=1,10
    DC 200 K=1,101
    ITOTAL(K)=1
200 PRINT(K)=TABLE(14)
    IFLAG=0
    DC 260 K=1,N
    IF (Y(K)-YT)205,205,260
205 IF (Y(K)-YL)260,260,210
210 XL=XMIN-XDELTA/2.
    XT=XMIN+XDELTA/2.
    DC 255 KA=1,101
    IF (X(K)-XL)250,215,215
215 IF (X(K)-XT)220,250,250
220 IF (PRINT(KA)-TABLE(14))240,230,240
230 ITA=IT(K)
    PRINT(KA)=TABLE(ITA)
    GC TO 260
240 ITOTAL(KA)=ITOTAL(KA)+1
    IFLAG=1
    GC TO 260
250 XL=XT
255 XT=XT+XDELTA
260 CONTINUE
    YT=YL
    YL=YL-YDELTA
    IF (IFLAG)265,278,265
265 DC 275 LA=1,101
    IF (ITOTAL(LA)-1)268,275,268

```

```

268 KK=ITCTAL(LA)
      IF (KK-9)272,272,270
270 KK=9
272 PRINT(LA)=TABLE(KK)
275 CONTINUE
278 CCNTINUE
      GO TO (280,300),L
280 IF (I-5)285,285,400
285 L=2
      YP=YT+YDELTA/2.
      WRITE (IO,290)YP,(PRINT(IXZ),IXZ=1,101)
290 FORMAT(1X,E12.4,1H+,101A1,1H+)
      GO TO 350
300 WRITE (IO,310)(PRINT(IXZ),IXZ=1,101)
310 FORMAT (13X,1H-,101A1,1H-)
350 CONTINUE
400 WRITE (IO,290)YMIN,(PRINT(IXZ),IXZ=1,101)
      WRITE (IO,100)
      XP(1)=XMIN
      XP(6)=XMAX
      XR=20.*XDELTA
      DC 410 I=2,5
410 XP(I)=XP(I-1)+XR
      WRITE (IO,420)(XP(IXZ),IXZ=1,6)
420 FORMAT(6(7X,E13.5))
      IF (IOUT)600,600,500
500 WRITE (IO,550)IOUT
550 FORMAT (/20X,9H**NOTE. I4,60H POINTS FELL OUTSIDE THE SPECIFIED L
      1IMITS AND WERE OMITTED. )
600 CCNTINUE
      RETURN
      END

```

```

        DIMENSION M(15,6),T(15),XMUHAT(6),SIGHAT(6),
1  WORK(9,9),XM(15),YM(15),FMT(20),VALUES(9,9,6),ML(15),ITER(6)
        DIMENSION XMEANT(6),STDEVT(6)
        INTEGER TOTAL
C
C      READ FORMAT , TOLERANCE , MAX NO. OF ITERATIONS ,NO. OF SAMPLES
C
        READ(1,100) FMT
100  FORMAT(20A4)
        READ(1,200) TOLER,NIT,L
200  FORMAT(F10.0,2I5  )
C
C      READ DATA FOR AN EXPERIMENT
C
205  READ(1,210) N,TOTAL
210  FORMAT(2I5)
        IF( N.EQ. 0 ) STOP
        DC 215 I=1,N
        READ(1,FMT)EXPNG,T(I),(XM(J),J=1,L)
        T(I)=ALOG(T(I))
        T(I)=ALOG(T(I))
        DC 215 J=1,6
215  M(I,J)=XM(J)
C
C      OUTPUT DATA
C
        WRITE(3,300) EXPNG
300  FORMAT(@1 EXPERIMENT NUMBER@,F4.0)
        WRITE(3,320)(I,I=1,L)
320  FORMAT(///10X,@ TIME  SAMPLE =@,6I10,/)
        DC 340 I=1,N
        WRITE(3,330) I,T(I),(M(I,K),K=1,L)
330  FORMAT(1X,I9,F7.1,11X,6I10)

```

```

340 CONTINUE
C
C   COMPUTE MAXIMUMS
C
   DO 360 I=1,L
   NWORK=M(N,I)
   DC 360 J=1,N
   K= N - J + 2
   M(K,I)= NWORK - M(K-1,I)
360 NWORK = M(K-1,I)
   DC 363 I=1,L
   XMEANT(I)=0.0
   STDEVT(I)=0.0
   NTOT=0
   DC 361 J=1,N
   XMEANT(I)=XMEANT(I)+M(J,I)*T(J)
361 NTOT=NTOT+M(J,I)
   XMEANT(I)=XMEANT(I)/FLOAT(NTOT)
   DC 362 J=1,N
362 STDEVT(I)=STDEVT(I)+M(J,I)*(T(J)-XMEANT(I))**2
363 STDEVT(I) = SQRT( STDEVT(I) / FLOAT(NTOT-1) )
   DC 400 I=1,L
   J=N+1
   DO 370 K=1,J
370 ML(K) =M(K,I)
   XMUHAT(I)=XMEANT(I)
   SIGHAT(I)=STDEVT(I)
   CALL FINDMX( VALUES(1,1,I),SIGHAT(I),XMUHAT(I),TOLER,NIT,ML,T,N,
1 ITER(I) )
400 CCNTINUE
C
C   FINISHED -- PRINT RESULTS
C

```

```

DC 485 I=1,L
XMEANT(I)=EXP(XMEANT(I))
XMEANT(I)=EXP(XMEANT(I))
XMUHAT(I)=EXP(XMUHAT(I))
XMUHAT(I)=EXP(XMUHAT(I))
485 CCNTINUE
WRITE(3,490)
490 FORMAT( /// @ INITIAL GUESSES@)
WRITE(3,500)(XMEANT(I),I=1,L)
WRITE(3,501)(STDEVT(I),I=1,L)
WRITE(3,500)(XMUHAT(I),I=1,L)
500 FORMAT(///,@ MU-HAT @,20X,6F10.6)
WRITE(3,501)(SIGHAT(I),I=1,L)
501 FORMAT(@@ SIGMA-HAT@,18X,6F10.6)
WRITE(2,502) EXPNG,(XMUHAT(I),I=1,L)
WRITE(2,502) EXPNO,(SIGHAT(I),I=1,L)
502 FORMAT(F4.0,6F12.5)

C
C   OUTPUT SURFACES
C
WRITE(3,600) NIT , TOLER
600 FORMAT(///,10X,@** SURFACES AROUND MAX ** , NO. OF ITERATIONS = C
1 IMPLIES MAXIMUM NOT FOUND IN LESS THAN@,I4, @ TRIES@,/,30X,@TCLER
2ENCE USED WAS@,F10.6,///)
DC 700 I=1,L
WRITE(3,601) I,ITER(I)
601 FORMAT(@@SAMPLE =@,I2,@ ,NO. OF ITERATIONS WAS@,I5//)
XM(1) = XMUHAT(I) - 4.0* TOLER
YM(1) = SIGHAT(I) - 4.0* TOLER
DC 610 J=2,9
XM(J) =XM(J-1) + TOLER
610 YM(J) =YM(J-1) + TOLER
WRITE(3,620)(XM(J),J=1,9)

```



```

620 FORMAT(@0@,50X,@ MU @,/,@ SIGMA@,7X,5F12.5,@*@,F11.5,3F11.5,/)
      DC 650 K=1,9
      IF( K .EQ. 5) GO TO 640
      WRITE(3,630) YM(K),(VALUES(K,J,I),J=1,9)
630 FORMAT(1X,10F12.5)
      GC TO 650
640 WRITE(3,645) YM(K),(VALUES(K,J,I),J=1,9)
645 FORMAT(1X, F12.5,@*@,F11.5,8F12.5)
650 CONTINUE
700 CONTINUE
      GC TO 205
      END

```

```

      SUBROUTINE FINDMX(WORK ,STDEV,XMU,TOLER,NIT,M,T,N,MAXFND)
C
C   FINDS MAXIMUM
C
      DIMENSION WORK(9,9),VALUE(3,3),M(1),T(1),X1(3),X2(3),X3(15)
      NIT1=0
10  X1(2)=STDEV
      X2(2)=XMU
      X1(1)=STDEV-TCLER
      X1(3)=STDEV+TCLER
      X2(1)=XMU-TCLER
      X2(3)=XMU+TOLER
      DC 100 I=1,3
      DC 100 J=1,3
      DO 50 K=1,N
50  X3(K)=(T(K)-X2(J))/X1(I)
      CALL WHEATN( N ,X3,M,VALUE(I,J) )
100 CONTINUE
      IMAX=2

```

```

      JMAX=2
      DC 120 I=1,3
      DC 120 J=1,3
      IF( VALUE(I,J) .LT. VALUE(IMAX,JMAX)) GO TO 120
      IMAX =I
      JMAX =J
120  CONTINUE
      STDEV=X1(IMAX)
      XMU=X2(JMAX)
      NIT1 = NIT1 + 1
      IF( NIT1 .EQ. NIT ) GO TO 500
      IF( IMAX .NE. 2 .OR. JMAX .NE. 2 ) GO TO 10
      MAXFND = NIT1
130  S=STDEV - 5.0*TOLER
      DC 200 I=1,9
      S=S+TOLER
      X=XMU - 5.0*TOLER
      DC 200 J=1,9
      X=X+TOLER
      DC 190 K=1,N
190  X3(K) =( T(K)-X )/S
      CALL WHEATN( N,X3,M,WORK(I,J) )
200  CONTINUE
      GO TO 600
500  MAXFND = 0
      GO TO 130
600  RETURN
      END

```

```

SUBROUTINE WHEATN( N , T , M , G )
DIMENSION T(1),M(1),X(25)
DC 10 I=1,N

```

```

10 X(I) = QNOR( T(I) )
   XZ = 1.0
   G=0.0
   DC 30 I=1,N
   J = N - I + 2
   Y=XZ-X(J-1)
   IF ( Y .LT. 1.0E-10 ) Y= 1.0E-10
   X(J)=M(J)*ALOG(Y)
   XZ = X( J-1 )
30 G = G + X( J )
   IF ( X(1) .LT. 1.0E-10 ) X(1) = 1.0E-10
   G = G + M(1)*ALOG( X(1) )
   RETURN
   END

```

```

C     FUNCTION QNOR(X)
C     X EQUALS A STANDARDIZED NORMAL OBSERVATION VALUE
C     QNOR(X) CALCULATES THE PROBABILITY OF AN OBSERVATION BEING LESS
C     THAN OR EQUAL TO THE NORMAL VARIAT X
   DIMENSION D(16)
   DATA D(1),D(2),D(3),D(4),D(5),D(6) / .0498673, .02114101,
1    .00327763, .000038, .00004889, .00000538 /
   Y=X
   IF (X.LT.0.0) Y=-X
   P=1.0
   DC 10 I=1,6
10 P=P+D(I)*(Y **I)
   P=1.0-.5/(P**16)
   QNOR=P
   IF (Y.NE.X) QNOR=1.0-QNOR
   RETURN
   END

```