



EDITION

6

Dental Instruments

A POCKET GUIDE

LINDA R. BARTOLOMUCCI BOYD

ELSEVIER



EVOLVE STUDY RESOURCES
FREE WITH TEXTBOOK PURCHASE
EVOLVE.ELSEVIER.COM

Dental Instruments

A Pocket Guide

SIXTH EDITION

Linda R. Bartolomucci Boyd, CDA, RDA, BA

Emeritus Professor, Registered Dental Assisting Program, Diablo Valley College, Pleasant Hill, California

ELSEVIER

Table of Contents

Cover image

Title page

Copyright

Dedication

Preface

New to This Edition

Acknowledgements

Photo/Illustration Credits

1. Basic Dental Instruments

Instrument

Instrument

Instrument

Instrument

Tray Setup

2. Enamel-Cutting Instruments

Instrument

Instrument

Instrument

Instrument

Instrument

Instrument

Instrument

Instrument

Instrument

Instrument

Instrument

3. Local Anesthetic Syringe/Components and Nitrous Oxide Sedation

- Instrument
- Instrument
- Instrument
- Instrument
- Instrument
- Instrument
- Instrument
- Instrument
- Instrument
- Instrument
- Tray Setup

4. Evacuation Devices, Air/Water Syringe Tip, and Dental Unit

- Instrument
- Instrument
- Instrument
- Instrument
- Instrument
- Instrument
- Instrument
- Instrument
- Instrument
- Instrument

5. Dental Handpieces

- Instrument
- Instrument
- Instrument
- Instrument
- Instrument
- Instrument
- Instrument
- Instrument
- Instrument
- Instrument
- Instrument
- Instrument
- Instrument
- Instrument
- Instrument

Instrument
Instrument
Instrument
Instrument
Instrument
Instrument
Instrument
Instrument
Instrument
Instrument
Instrument
Instrument
Instrument
Instrument
Instrument
Instrument
Instrument
Instrument
Instrument
Instrument
Tray Setup

9. Composite Restorative Instruments

Instrument
Instrument
Instrument
Instrument
Instrument
Instrument
Instrument
Instrument
Instrument
Instrument
Tray Setup
Tray Setup

10. Fixed Prosthodontics Restorative Instruments

Instrument
Instrument
Instrument
Instrument
Instrument
Instrument
Instrument
Instrument
Instrument

Instrument
Instrument
Instrument
Instrument
Instrument
Instrument
Instrument
Instrument
Instrument
Instrument
Instrument
Instrument
Tray Setup
Tray Setup

13. Preventive and Sealant Instruments and Whitening Trays

Instrument
Instrument
Instrument
Instrument
Instrument
Instrument
Instrument
Instrument
Tray Setup
Tray Setup
Tray Setup

14. Orthodontic Instruments

Instrument
Instrument
Instrument
Instrument
Instrument
Instrument
Instrument
Instrument
Instrument
Instrument
Instrument
Instrument
Instrument
Instrument
Instrument

Instrument
Instrument
Instrument
Instrument
Instrument
Instrument
Instrument
Instrument
Instrument
Instrument
Instrument
Instrument
Instrument
Instrument
Instrument

19. Dental Materials Equipment

Instrument
Instrument
Instrument
Instrument
Instrument
Instrument
Instrument
Instrument
Instrument
Instrument
Instrument
Instrument
Instrument
Instrument
Instrument
Instrument
Instrument
Instrument
Instrument
Instrument
Instrument

20. Dental Imaging and Diagnostic Equipment

Instrument
Instrument
Instrument
Instrument
Instrument

Copyright

ELSEVIER

3251 Riverport Lane
St. Louis, Missouri 63043

DENTAL INSTRUMENTS: A POCKET GUIDE, SIXTH EDITION ISBN: 978-0-323474054

Copyright © 2018, Elsevier Inc. All rights reserved.

Previous editions copyrighted 2015, 2012, 2009, 2005, and 2003.

No part of this publication may be reproduced or transmitted in any form or by any means, electronic or mechanical, including photocopying, recording, or any information storage and retrieval system, without permission in writing from the publisher. Details on how to seek permission, further information about the Publisher's permissions policies and our arrangements with organizations such as the Copyright Clearance Center and the Copyright Licensing Agency, can be found at our website: www.elsevier.com/permissions.

This book and the individual contributions contained in it are protected under copyright by the Publisher (other than as may be noted herein).

Notices

Knowledge and best practice in this field are constantly changing. As new research and experience broaden our understanding, changes in research methods, professional practices, or medical treatment may become necessary.

Practitioners and researchers must always rely on their own experience and knowledge in evaluating and using any information, methods, compounds, or experiments described herein. In using such information or methods they should be mindful of their own safety and the safety of others, including parties for whom they have a professional responsibility.

With respect to any drug or pharmaceutical products identified, readers are advised to check the most current information provided (i) on procedures featured or (ii) by the manufacturer of each product to be administered, to verify the recommended dose or formula, the method and duration of administration, and contraindications. It is the responsibility of practitioners, relying on their own experience and knowledge of their patients, to make diagnoses, to determine dosages and the best treatment for each individual patient, and to take all appropriate safety precautions.

To the fullest extent of the law, neither the Publisher nor the authors, contributors, or editors, assume any liability for any injury and/or damage to persons or property as a matter of products liability, negligence or otherwise, or from any use or operation of any methods, products, instructions, or ideas contained in the material herein.

ISBN: 978-0-323474054

Senior Content Strategist: Kristin Wilhelm
Content Development Specialist: Katie Gutierrez
Senior Content Development Specialist: Courtney Sprehe

Publishing Services Manager: Unni Deepthi
Senior Project Manager: Umarani Natarajan
Design Direction: Brian Salisbury

Printed in China

Last digit is the print number: 9 8 7 6 5 4 3 2 1



Dedication

To Cathy Clarke . . . My appreciation for all of your expertise and dedication with your insight pertaining to innovative ideas for this edition as well as the past editions. Thank you!

To my college nieces and nephews, Raymond, Francesca, David, and Sophia, from whom I have learned the intricate way this current generation absorbs information and processes learning. Ti Amo!

Preface

It is with great pleasure that I present the sixth edition of *Dental Instruments: A Pocket Guide*.

Many new additions have been added to this text. First, the Sterilization Notes have more detailed information on how to process instruments. Second, many new photos were taken to enhance the working end as well as the entire instrument for clarity. Third, on the text page, many new photos are inserted to demonstrate the instrument “in use.” Also, new technology equipment has been added, as well as new models of technology that already existed in the previous editions.

This text is designed to help dental students and practicing professionals master the identification and use of common and specialty dental instruments and equipment. Whereas certain chapters focus on the instruments used in all dental practices, such as components of the basic tray setup, the anesthetic syringe and its parts, evacuation devices, and so on, other chapters are designed around various routine dental procedures, such as the instruments used in hygiene, amalgam, and composite procedures. The dental specialty chapters include instruments used in prosthodontics, orthodontics, endodontics, and periodontics. Three chapters focus on oral surgery—one addresses the general surgical instruments used in oral and periodontal surgery, and the other two focus on surgical extractions and implants. The third focuses on periodontal instruments. Significant advances in detection of oral cancer equipment have been added to this text as well. There are also chapters devoted to dental material equipment.

Additionally, in keeping with the concept of total patient care, the chapter called “Vital Signs and Beyond” focuses on the equipment used to monitor patients for routine dental treatment as well as treatment of sedated patients. At the end of most chapters, there are examples of tray setups, enhancing the reader’s ability to set up trays and use the instruments in the correct sequence, depending on the procedure.

In the 21st century, dentistry has certainly evolved with technology. It is more important than ever for students and clinicians to have an excellent understanding of the instruments and equipment they will encounter in practice. This sixth edition will help students and the clinicians stay current with the quickly changing technology of dentistry, as well as more detailed information on some instruments in the text pages. However, although basic dental instruments and equipment have remained relatively unchanged throughout the years, there have also been new advances that accommodate new technology in the dental field. These include, but are not limited to, the development of heat-resistant metals, synthetic material used for dental instruments, and new equipment. Examples can be seen in the special coatings available on some instruments, such as the titanium coating found on composite instruments that allow these instruments to be adapted to the different types of materials, as well as new designs of instruments.

I am confident that this text will help you to more easily learn the dental instruments, dental equipment, and tray setups that clinicians use in dental practices. It is imperative that all students begin their careers with a thorough knowledge of dental instruments and equipment and that they expand their knowledge throughout their careers. Certainly, this text will help you achieve these goals. I wish you all success in the field of dentistry. I know you will be a great asset to the dental profession!

Linda R. Bartolomucci Boyd

New to This Edition

- **Several new photos** in many chapters, including both a full-instrument view and close-up views to better see the working ends of the instruments to assist in easier identification
- **Additional “in use”** photos and illustrations of instruments and equipment to enhance the understanding of the function in specific procedures
- **Sequence of instruments** in the chapters have changed to give a better understanding of method of use for procedures.
- **Addition of new instruments and equipment**, including dental hygiene instruments and orthodontic equipment, as well as new technology on oral cancer detection.

Features of this Text

- **Flashcard format** makes it easy to quiz yourself on dental instruments and their uses.
- **More than 700 high-quality photographs and illustrations** enhance your ability to quickly and accurately identify dental instruments.
- Convenient **spiral-bound design** helps you easily access key information at a glance as well as use the pages as a **flash card technique** for studying.
- **Clear, consistent organization** helps you master basic instruments before introducing more complicated instruments.
- **Tray setups** (Note: The tray setups usually only have an example of instruments for the designated procedure; they do not include any axillary items needed for that particular procedure, such as cotton rolls or 2 × 2 gauze.)
Each written page has information on each individual instrument including:
 - Name of the instrument
 - Main function of the instrument
 - Characteristics of the instrument
 - Practice Note
 - Sterilization Note
- In addition to the Sterilization Note on each written page, it should be noted that instruments and items used during dental procedures are categorized as critical, semicritical, or noncritical. Below are excerpts from the *Guidelines for Infection Control in Dental Health-Care Settings—2003* that explain the categories.
 - “Patient-care items (dental instruments, devices, and equipment) are categorized as critical, semicritical, or noncritical, depending on the potential risk for infection associated with their intended use. . . . Critical items used to penetrate soft tissue or bone have the greatest risk of transmitting infection and should be sterilized by heat. Semicritical items touch mucous membranes or nonintact skin and have a lower risk of transmission; because the majority of semicritical items in dentistry are heat-tolerant, they also should be sterilized by using heat. If a semicritical item is heat-sensitive, it should, at a minimum, be processed with high-level disinfection. . . .
 - “Noncritical patient-care items pose the least risk of transmission of infection, contacting only intact skin, which can serve as an effective barrier to microorganisms. In the majority of cases, cleaning, or if visibly soiled, cleaning followed by disinfection with an EPA-registered hospital disinfectant is adequate. When the item is visibly contaminated with blood or OPIM, an EPA-registered hospital disinfectant with a tuberculocidal claim (i.e., intermediate-level disinfectant) should be used. . . . Cleaning or disinfection of certain noncritical patient-care items can be difficult or damage the surfaces; therefore, use of disposable barrier protection of these surfaces might be a preferred alternative.”
 - For detailed information regarding guidelines for infection control in a dental setting please refer to *Guidelines for Infection Control in Dental Health-Care Settings—2003* at <http://www.cdc.gov/mmwr/index.html>.

Evolve

For the Student

Chapter Quizzes • Drag-and-Drop Tray Setup Exercises • Tray Setup Quizzes

For the Instructor

Image Collection for Power Point Presentation and Testing • Test Bank

Acknowledgements

My deepest appreciation is to acknowledge all of my colleagues, dentist affiliations, professors, and my dearest family and friends for all of their insight, support, love, and prayers during the writing of this sixth edition. Of course, I value each and every student because their zest and enthusiasm for learning give me such encouragement to write a text that enhances their desire to learn.

Two people have played an incredible role in making this text such a great learning tool with the availability of the instruments and the creative skill in photography. First and foremost, I have the greatest respect for Jeff McMillian in his ability to photograph dental instruments. Jeff's artistic ability and incredible photography skills have enhanced this text with clearer and more precise photographs, especially the close-up working ends of dental instruments and the all-new photographs of the instruments "in use." Second, these photographs would not be possible without Andrew Hartzell, president of G. Hartzell & Son, Inc., who allowed me to borrow most of the instruments to photograph. Thank you, Andy!

I am absolutely grateful to Katie Gutierrez, content development specialist, and to Courtney Sprehe, senior content development specialist, for their development of the sixth edition of this text. Courtney's vision and mine have remained the same from the second edition to now the sixth. Kristin Wilhelm, I thank you for your expertise as editor in overseeing and publishing this sixth edition.

I continue to express my thanks to **Joyce M. Litch, RDH, DDS, MSD**, for her expertise as a consultant to the book, who assisted in developing the periodontal and hygiene chapters. I thank you for always being there for me! **Ann Marie Gorczykca, DMD, MPH, MS**, you are amazing in your enthusiasm in encouraging me to always follow my passion. Thank you, for your words of praise and encouragement in the ongoing process of publishing and your expertise in knowledge of orthodontics and beyond. The bur chapter would not be as comprehensive without the consultation from **Wayne Joseph, DDS**. His insight into this chapter has been appreciated from the first edition to the sixth.

I would like to express my deepest gratitude to **Cathy Clarke, RDA, CDA, BA**, to whom this book is dedicated, who spent numerous hours and days as a consultant to many aspects of this text. Thank you for always being available to answer my questions at any time.

A very special thank you to Paul Charles Hans, BS, MBA, an author himself, for his ability in keeping my focus in the process of the photography as well as the creative technical writing of this text. Your love, support, and encouragement mean more to me than I can express.

I could not have written this sixth edition without the love, support, and prayers from my family: my sons, Michael and Matthew, who always gave me a nudge of encouragement; my cousin Elaine Strizzi, for her gentle and loving ways of support; and my brother and sister-in-law, Ray and Meri, for the nourishment of my body and soul during this process. Also, the concept my parents taught me, "To honor the dream inside of me," constantly resonates in my mind. Last, but certainly not least, are the wonderful, refreshing moments with my grandchildren, Christian, Collin, Liberty Rae, Alexis, Jaxson, and Maxwell, who teach me the simplicity, enthusiasm, and zest for learning that encourages my writing. Ti Amo!

Linda R. Bartolomucci Boyd

For information about the author or to ask questions about the text, please contact lrboyd47@yahoo.com.

Photo/Illustration Credits

Photo/Illustration Credits (Manufacturers)

Photos on the following pages are courtesy of:

3M ESPE: p. 640 [www.3m.com]

3M Littmann Stethoscopes: p. 722 [www.littmann.com]

Acteon North America: p. 102 [www.acteonusa.com]

A-dec Inc.: pp. 72 (right), 74, 76, 78, 80, 108, 112 [www.a-dec.com]

Air Techniques, Inc.: pp. 394, 690, 710 [www.airtechniques.com]

Align Technology, Inc. (Invisalign clear aligners): pp. 466 (right), 467 (bottom) [www.aligntech.com]

Alfa Medical: p. 620 [www.alfa-medical.com]

Carestream Health, Inc.: 668, 712 [www.carestreamdental.com]

Coltène/Whaledent, Inc.: p. 312 [www.coltene.com]

Criticare Technologies Inc.: 730, 732 [www.criticareusa.com]

Dentsply Sirona: pp. 90, 92, 94, 98, 100, 106, 110, 116, 120, 122, 124, 126, 128, 130, 132, 134, 136, 138, 140, 142, 194, 268, 270, 466 (left), 467 (top), 686, 694, 696, 698, 700, 702, 704, 705, 706, 714 [www.dentsplysirona.com]

DynaFlex: pp. 404, 408 (right), 444, 445 [www.dynaflex.com]

Garrison Dental Solutions: p. 232 [www.garrisondental.com]

GE Healthcare: p. 728 [www.gehealthcare.com]

GettyImages.com: p. 586 [www.gettyimages.com]

Hu-Friedy Mfg. Co., LLC: pp. 48 (right), 174, 176, 178, 180, 300, 362, 363, 364, 366, 368, 370, 374, 592, 594, 596, 598, 600, 602, 604, 608, 658 [www.hu-friedy.com]

i-CAT: p. 716 [www.i-cat.com]

Innoden, LLC (BiOX portable x-ray unit): p. 708 [www.innoden.com]

Isolite Systems: pp. 66-67 [www.isolitesystems.com]

Ivoclar Vivadent: p. 202 (left) [www.ivoclarvivadent.com]

Kavo Kerr: pp. 72 (left), 86, 88, 392, 246, 247, 282, 304, 384, 385, 630, 634, 638, 647, 678, 682 [www.kavokerrgroup.com]

Kerr Corporation, on behalf of Pentron Clinical Technologies, LLC: pp. 644, 646 [www.pentron.com]

LED Dental Inc.: p. 718 [www.leddental.com]

Midmark Corp.: pp. 612, 614 [www.midmark.com]

Milestone Scientific, Inc. (2016. All Rights Reserved. Used by Permission.): pp. 50, 51 [www.milestonescientific.com]

Mirion Technologies, Dosimetry Service Division: p. 680 [www.mirion.com]

Obtura Spartan Endodontics: p. 316 [www.obtura.com]

Patterson Dental Co. Inc.: p. 408 (left) [www.pattersondental.com]

Paradise Dental Technologies (PDT), Inc.: p. 358 [www.pdtdental.com]
 Porter Instruments Division, Parker Hannifin Corp: pp. 54 (left), 56 [www.porterinstrument.com]
 Practicon Inc.: pp. 54 (right), 660 [www.practicon.com]
 Premier Dental: pp. 292, 294, 296 [www.premusa.com]
 SciCan Inc. (STATIM G4): p. 616 [www.scican.com]
 Tatum Surgical: p. 570 [www.tatumsurgical.com]
 Vita North America, Inc.: pp. 258, 259 [www.vitanorthamerica.com]
 Wayne Metal Products: p. 618 [www.waynemetalsproductsinc.com]
 Whip Mix Corporation: pp. 256, 257, 650, 652 [www.whipmix.com]
 Zest Dental Solutions: p. 104 [www.zestanchors.com]
 Zewa Inc.: p. 726 [www.zewa.com]
 ZOLL Medical Corporation: p. 734 [www.zoll.com]

Photo/Illustration Credits (Books)

Aschheim KW: *Esthetic dentistry: a clinical approach to techniques and materials*, ed 3, St. Louis, 2015, Mosby—illustration on page 391

Baum L, Phillips RW, Lund MR: *Textbook of operative dentistry*, ed 3, Philadelphia, 1995, Saunders—illustrations on pages 5, 16 (right), 23, 35, 121, 123, 125, 127, 169, 171

Bird DL, Robinson DS: *Torres and Ehrlich modern dental assisting*, ed 8, St. Louis, 2005, Saunders—illustrations on pages 205, 207

Bird DL, Robinson DS: *Torres and Ehrlich modern dental assisting*, ed 9, St. Louis, 2009, Saunders—illustration on page 674

Bird DL, Robinson DS: *Modern dental assisting*, ed 11, St. Louis, 2015, Elsevier—illustrations on pages 131, 133, 261

Bird DL, Robinson DS: *Modern dental assisting*, ed 12, St. Louis, 2018, Elsevier—illustrations on pages 3, 7, 63, 65, 97, 175, 190, 202, 209, 219, 243, 383, 585, 587, 597, 625, 627, 631, 642, 649, 651, 657, 666, 687, 695, 712

Convissar RA: *Principles and practice of laser dentistry*, ed 2, St. Louis, 2016, Mosby—illustration on page 393

Darby ML, Walsh M: *Dental hygiene: theory and practice*, ed 4, St. Louis, 2015, Saunders—illustrations on pages 55 (Courtesy Dr. Mark Dellinges), 163, 183, 193, 197, 199, 213, 263

Dean JA, Avery DR, McDonald RE: *McDonald and Avery dentistry for the child and adolescent*, ed 10, St. Louis, 2016, Elsevier—illustrations on pages 265, 483

Fairchild SL: *Pierson and Fairchild's principles and techniques of patient care*, ed 5, St. Louis, 2013, Saunders—illustration on page 735

Fehrenbach MJ, Herring SW: *Illustrated anatomy of the head and neck*, ed 5, St. Louis, 2017, Elsevier—illustration on page 39 (Photo courtesy Margaret Fehrenbach)

Freedman G: *Contemporary esthetic dentistry*, St. Louis, 2012, Mosby—illustration on page 388

Garg AK: *Implant dentistry*, ed 2, St. Louis, 2010, Mosby—illustration on page 549

Graber TM, Vanarsdall RL, Vig KWL: *Orthodontics: current principles and techniques*, ed 4, St. Louis, 2006, Mosby—illustration on page 418

Graber LW, Vanarsdall RL, Vig KWL, et al: *Orthodontics: current principles and techniques*, ed 6, St. Louis, 2017, Elsevier—illustration on page 459

Gutmann JL, Lovdahl PE: *Problem solving in endodontics: prevention, identification and management*, ed 5, St. Louis, 2011, Mosby—illustrations on pages 485, 497

Hargreaves KM, Berman LH: *Cohen's pathways of the pulp*, Expert Consult, ed 11, St. Louis,

2016, Elsevier—illustrations on pages [287](#), [313](#), [317](#), [321](#)

Hatrick CD, Eakle WS, Bird WF: *Dental materials: clinical applications for dental assistants and dental hygienists*, St. Louis, 2003, Saunders—illustration on page [354](#)

Hatrick CD, Eakle WS, Bird WF: *Dental materials: clinical applications for dental assistants and dental hygienists*, ed 3, St. Louis, 2016, Elsevier—illustrations on pages [153](#), [245](#), [249](#), [641](#), [643](#), [659](#)

Heymann HO, Swift EJ, Ritter AV: *Strudevant's art and science of operative dentistry*, ed 6, St. Louis, 2013, Mosby—illustration on page [31](#)

Hupp JR, Ellis E, Tucker MR: *Contemporary oral and maxillofacial surgery*, ed 6, St. Louis, 2014, Mosby—illustrations on pages [495](#), [535](#), [555](#), [606](#), [681](#)

Iannucci J, Howerton LJ: *Dental radiography: principles and techniques*, ed 5, St. Louis, 2017, Elsevier—illustrations on pages [688](#), [692](#) (adapted)

Malamed SF: *Handbook of local anesthesia*, ed 6, St. Louis, 2013, Mosby—illustration on page [45](#)

Malamed SF: *Sedation: a guide to patient management*, ed 5, St. Louis, 2010, Mosby—illustration on page [481](#)

Newman MG, Takei H, Klokkevold PR, Carranza FA: *Carranza's clinical periodontology*, ed 11, St. Louis, 2012, Saunders—illustrations on pages [343](#), [345](#), [372](#), [373](#), [511](#), [517](#)

Papadopoulos MA, Tarawneh F: The use of miniscrew implants for temporary skeletal anchorage in orthodontics: a comprehensive review. *Oral Surgery, Oral Medicine, Oral Pathology, Oral Radiology, and Endodontology*, 103(5): e6-e15, 2007—illustration on page [468](#) (left)

Perry DA, Beemsterboer PL: *Periodontology for the dental hygienist*, ed 4, St. Louis, 2014, Saunders—illustrations on pages [355](#), [513](#), [572](#)

Proctor DB, Young-Adams AP: *Kinn's the medical assistant: an applied learning approach*, ed 13, St. Louis, 2017, Elsevier—illustrations on pages [724](#), [729](#)

Proffit WR, Fields HW, Sarver DM: *Contemporary orthodontics*, ed 5, St. Louis, 2013, Mosby—illustrations on pages [405](#), [407](#), [419](#), [439](#), [441](#), [461](#)

Robinson DS, Bird DL: *Essentials of dental assisting*, ed 5, St. Louis, 2013, Saunders—illustration on page [118](#)

Rose LF, Mealey BL, Genco RJ, Cohen W: *Periodontics: medicine, surgery and implants*, St. Louis, 2004, Mosby—illustrations on pages [503](#), [519](#)

Rosenstiel SF, Land MF, Fujimoto J: *Contemporary fixed prosthodontics*, ed 4, St. Louis, 2006, Mosby—illustration on page [155](#)

Rosenstiel SF, Land MF, Fujimoto J: *Contemporary fixed prosthodontics*, ed 5, St. Louis, 2016, Elsevier—illustrations on pages [137](#), [143](#), [155](#), [273](#), [307](#), [315](#)

Singh PP, Cranin AN: *Atlas of oral implantology*, ed 3, St. Louis, 2010, Mosby—illustrations on pages [293](#), [489](#), [491](#), [545](#)

White SC, Pharoah MJ: *Oral radiology: principles and interpretation*, ed 7, St. Louis, 2014, Mosby—illustration on page [684](#) (adapted)

Basic Dental Instruments

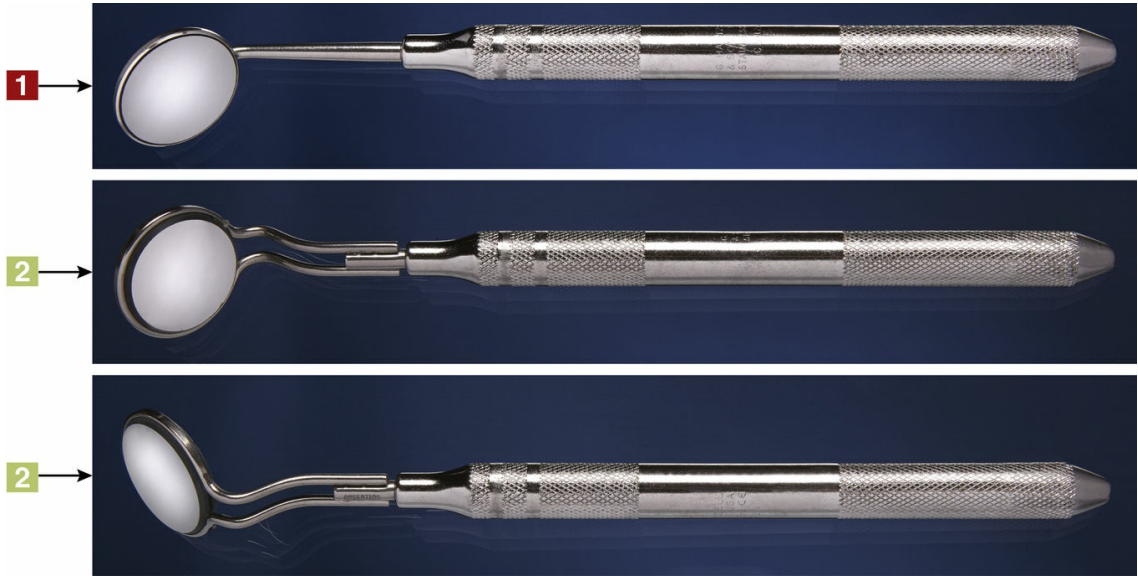

Instrument

Mouth Mirror

Functions

- To provide indirect vision
- To retract lips, cheeks, and tongue
- To reflect light into the mouth

Characteristics

- Front surface mirrors—Accurate, distortion-free image
- Double-sided mirrors—Used to retract tongue or cheek and view intraoral cavity simultaneously

Flat surface mirrors—Used in disposable mirrors

Concave mirrors—Magnify image

Range of sizes

Commonly used sizes: no. 4 and no. 5; refer to diameter of mirror

Single ended

Different mirror handles available (see p. 8)

Practice Notes

Mouth Mirror is used on most tray setups.

Sterilization Notes

Mouth Mirror must be precleaned, either, placed in a sterilizing pouch with an internal process indicator, sealed, then sterilized OR wrapped with an internal process indicator inside and secured on the outside with process indicator tape, then sterilized. Verify appropriate color change has been achieved in external process indicator immediately after removal from sterilizer then check internal process indicator before treatment. Refer to state regulations for any additional state requirements.



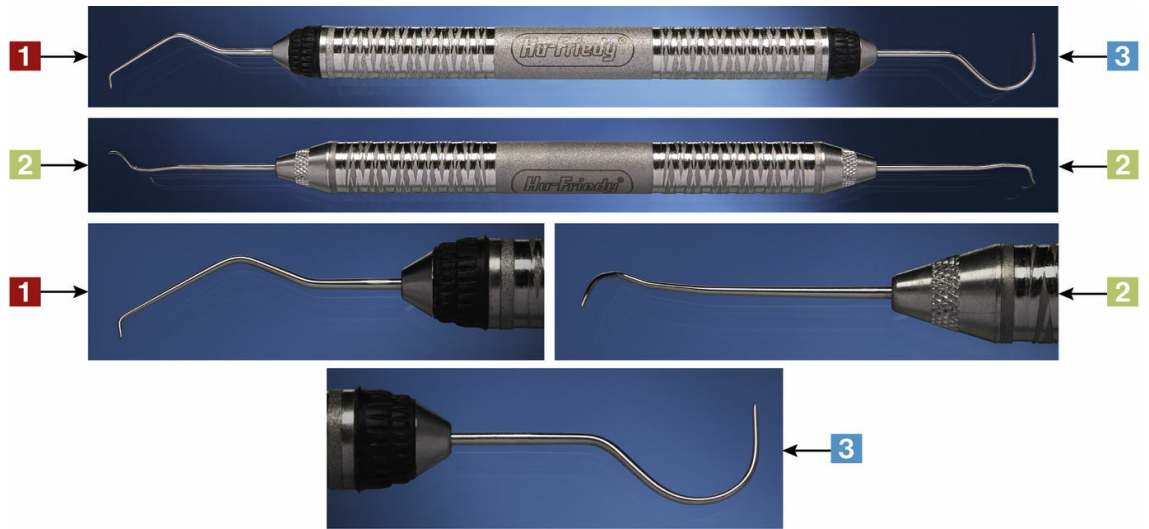

Instrument

Explorers

Function

To examine teeth for decay (caries), calculus, furcations, or other abnormalities

Characteristics

Pointed tips; sharp, thin, flexible

Single or double ended

- Double-ended models—May have the same style on working ends or different styles of working ends; may also have explorer on one end and periodontal probe on the other end (for periodontal probe, see [Chapter 16](#)).

Variety of sizes and types:

- Orban
- Pigtail
- Shepherd's hook

Practice Notes

Explorer is used on most tray setups.

Sterilization Notes

Explorer must be precleaned, either, placed in a sterilizing pouch with an internal process indicator, sealed, then sterilized OR wrapped with an internal process indicator inside and secured on the outside with process indicator tape, then sterilized. Verify appropriate color change has been achieved in external process indicator immediately after removal from sterilizer then check internal process indicator before treatment. Refer to state regulations for any additional state requirements.

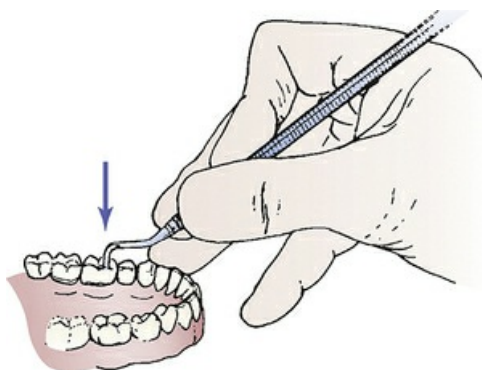

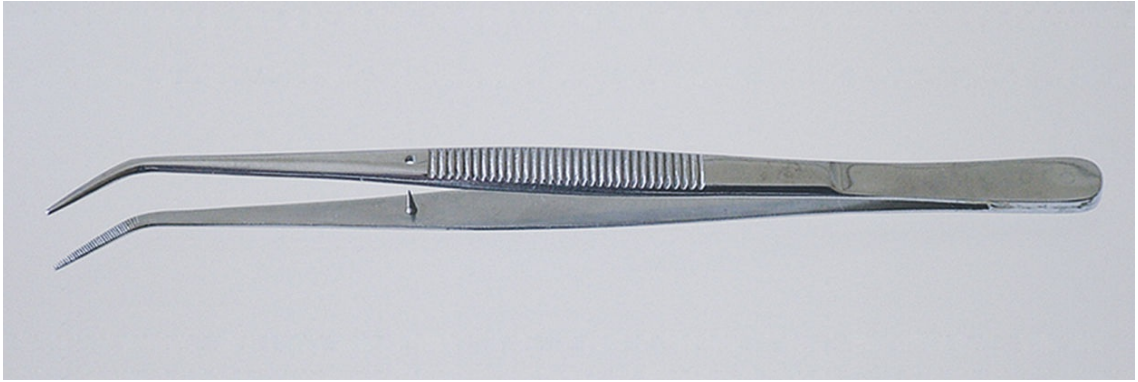

Instrument

Cotton Forceps (Pliers)

Function

To grasp or transfer items and/or material into and out of the oral cavity

Characteristics

Plain or serrated tips

Pointed or rounded tips

Thin or thick tips

Locking forceps (see [Chapter 11](#))

Range of sizes available

Practice Notes

Cotton Forceps is used on most tray setups.

Sterilization Notes

Cotton Forceps must be precleaned, either, placed in a sterilizing pouch with an internal process indicator, sealed, then sterilized OR wrapped with an internal process indicator inside and secured on the outside with process indicator tape, then sterilized. Verify appropriate color change has been achieved in external process indicator immediately after removal from sterilizer then check internal process indicator before treatment. Refer to state regulations for any additional state requirements.

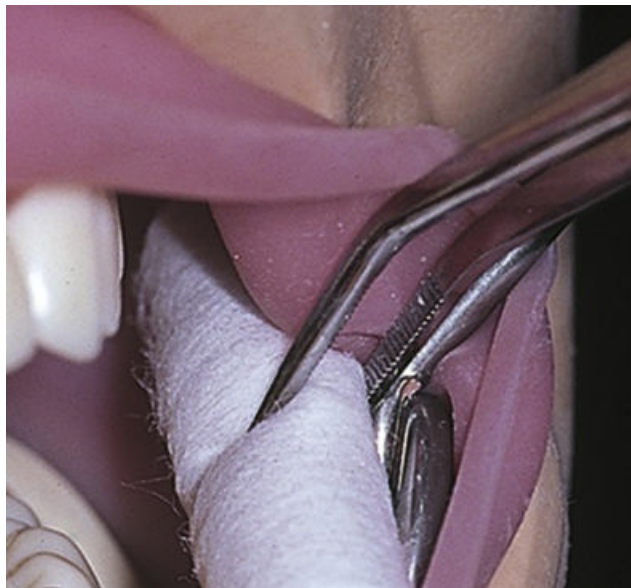

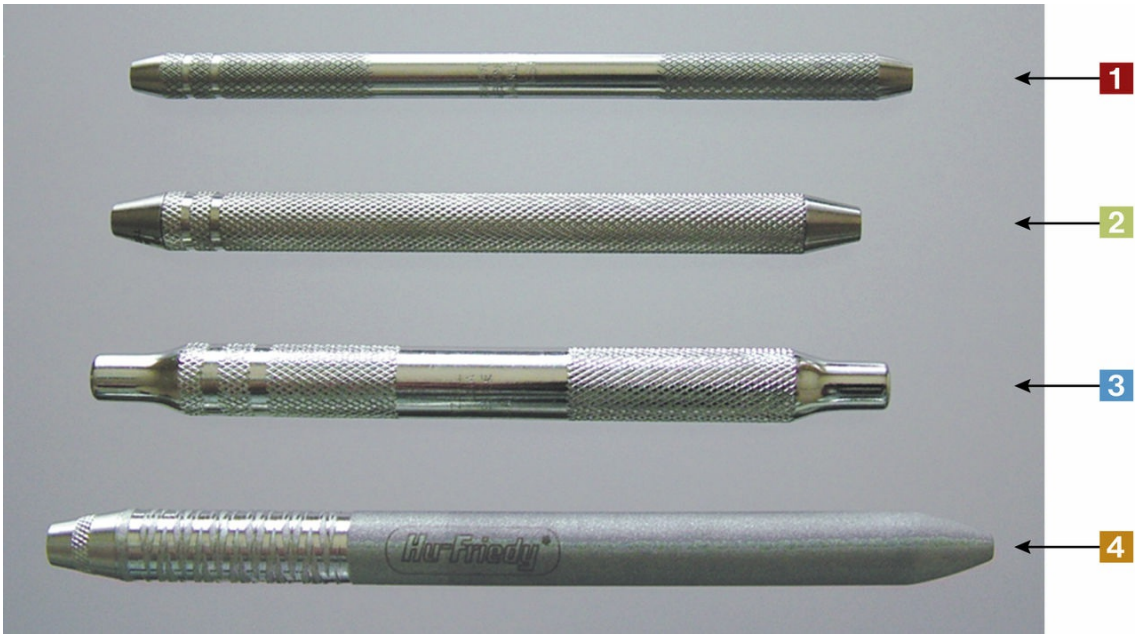

Instrument

Instrument Handles

Function

To hold (grasp) instrument

Characteristics

Single or double ended

Removable working ends (replaceable and interchangeable) attach to handle

Examples

Mouth mirror, scaler

Nonremovable working ends also available (commonly used)

Larger diameter models—Help lighten grasp and maximize control

Alternating diameter models—Lessen stress associated with carpal tunnel syndrome

Lighter weight models—Minimize fatigue

Variety of sizes, styles, and textures:

- Small, round ¼-inch stainless steel
- Standard, hollow 5/16-inch stainless steel
- Lightweight, 3/8-inch slip-resistant pattern
- Satin steel model—Lightweight, ergonomically designed

Sterilization Notes

Instrument Handles must be precleaned, either, placed in a sterilizing pouch with an internal process indicator, sealed, then sterilized OR wrapped with an internal process indicator inside and secured on the outside with process indicator tape, then sterilized. Verify appropriate color change has been achieved in external process indicator immediately after removal from sterilizer then check internal process indicator before treatment. Refer to state regulations for any additional state requirements.

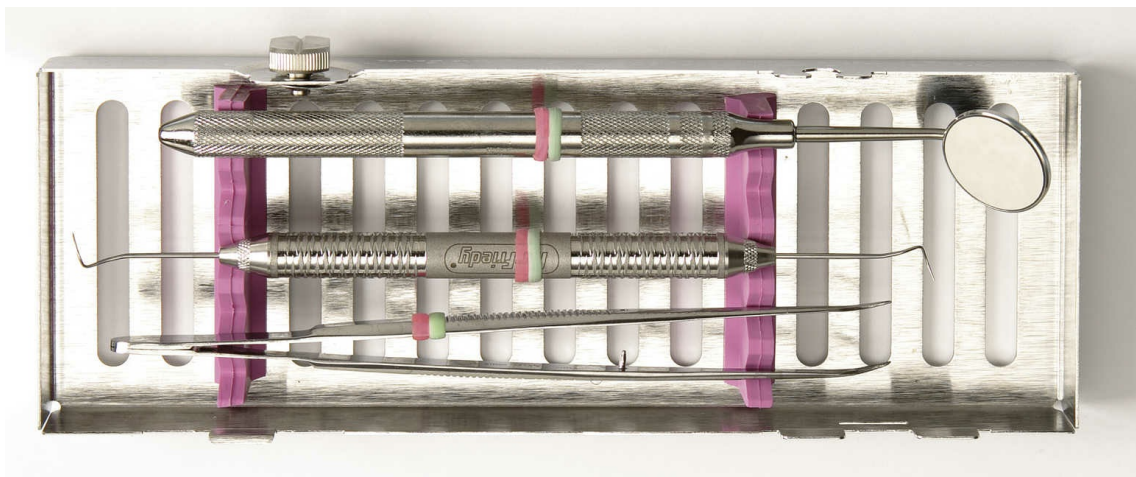

Tray Setup

Basic

From Top to Bottom

Mouth mirror, explorer (pigtail explorer pictured), cotton forceps (example of color-coded instruments in a cassette)

Practice Notes

Basic Setup is found on almost all dental tray setups.

Sterilization Notes

Basic Setup instruments with cassette must be precleaned, either, placed in a sterilizing pouch with an internal process indicator, sealed, then sterilized OR wrapped with an internal process indicator inside and secured on the outside with process indicator tape, then sterilized. Verify appropriate color change has been achieved in external process indicator immediately after removal from sterilizer then check internal process indicator before treatment. Refer to state regulations for any additional state requirements.

Enamel-Cutting Instruments

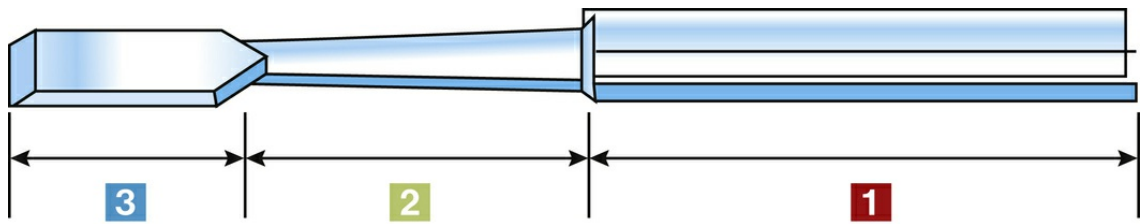

Instrument

Parts of an Instrument

■. Handle

Grasping end of instrument
Variety of sizes and styles
Handle styles (refer to pp. 8 & 9)

■. Shank

Connects handle to working end of instrument
May be straight or may have one or more angles to accommodate specific areas of the mouth

■. Working End

May have cutting edge, blade, bevel, point, nib, or beaks

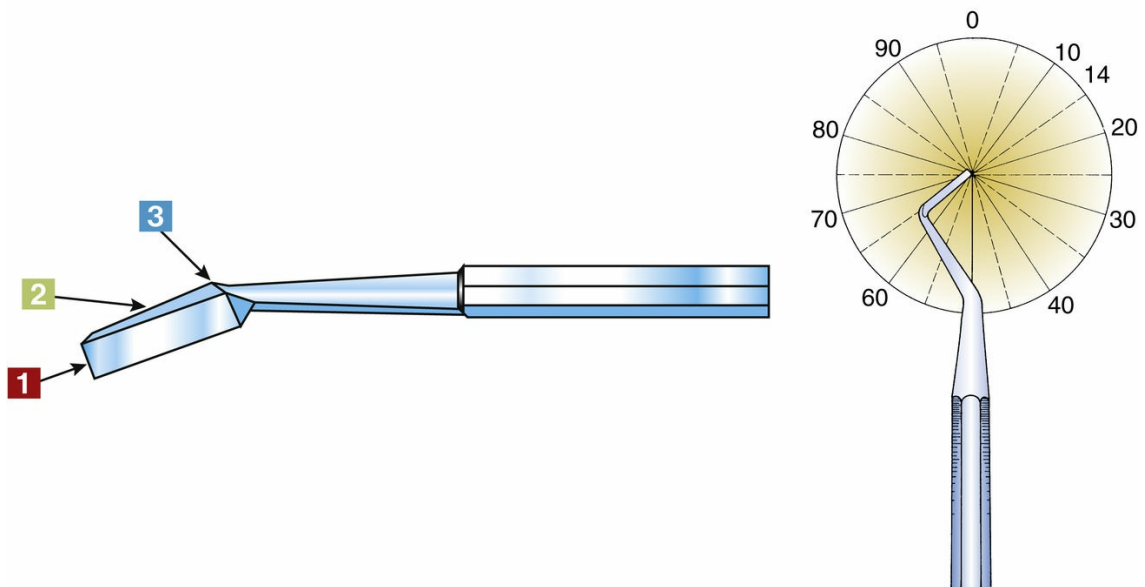

Instrument

Three-Numbered Instrument*

Function

Numbers on handle indicate width, length, and angle of blade.

- Indicates width of blade in tenths of millimeters

Example

20 indicates a width of 2 mm

- Indicates length of blade in millimeters

Example

8 indicates a length of 8 mm

- Indicates angle of blade from long axis of shaft

Example

12 indicates an angle of 12 degrees

The designation for the instrument described above is 20-8-12; the number of instrument size is indicated on the handle.

Examples of three-numbered instruments

Enamel, Hatchet, Enamel, Hoe, Wedelstaedt

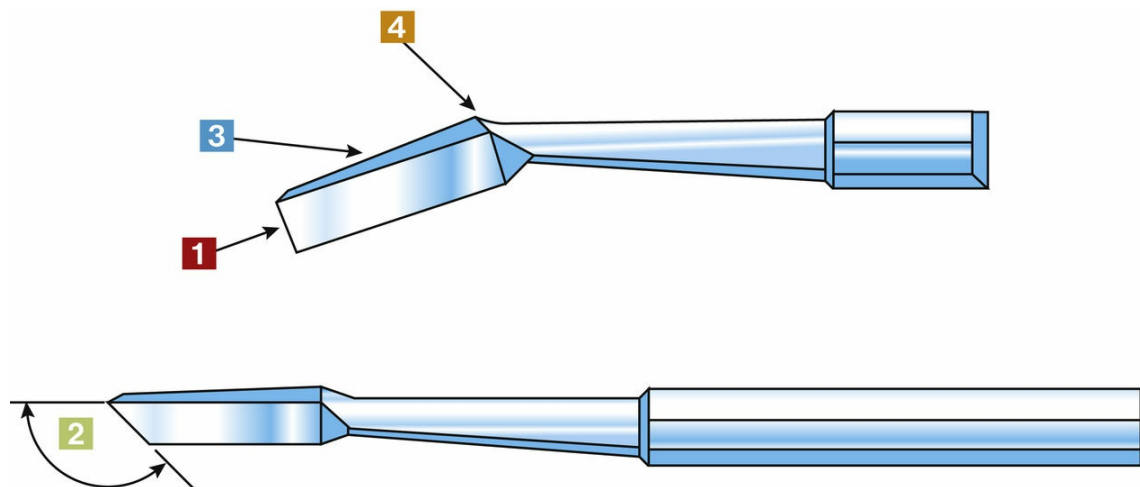

Instrument

Four-Numbered Instrument*

Function

Numbers on handle indicate width of blade, angle of cutting edge, length of blade, and angle of blade.

- Indicates width of blade in tenths of millimeters

Example

20 indicates a width of 2 mm

- Indicates angle of cutting edge of blade in relation to handle

Example

95 indicates a cutting edge angle of 95 degrees

- Indicates length of blade in millimeters

Example

8 indicates a length of 8 mm

- Indicates angle of blade from long axis of shaft

Example

12 indicates a blade angle of 12 degrees

The designation for the instrument described above is 20-95-8-12; The number of instrument size is indicated on the handle.

Examples of four-numbered instruments

Angle Former, Gingival Margin Trimmers—Mesial and Distal

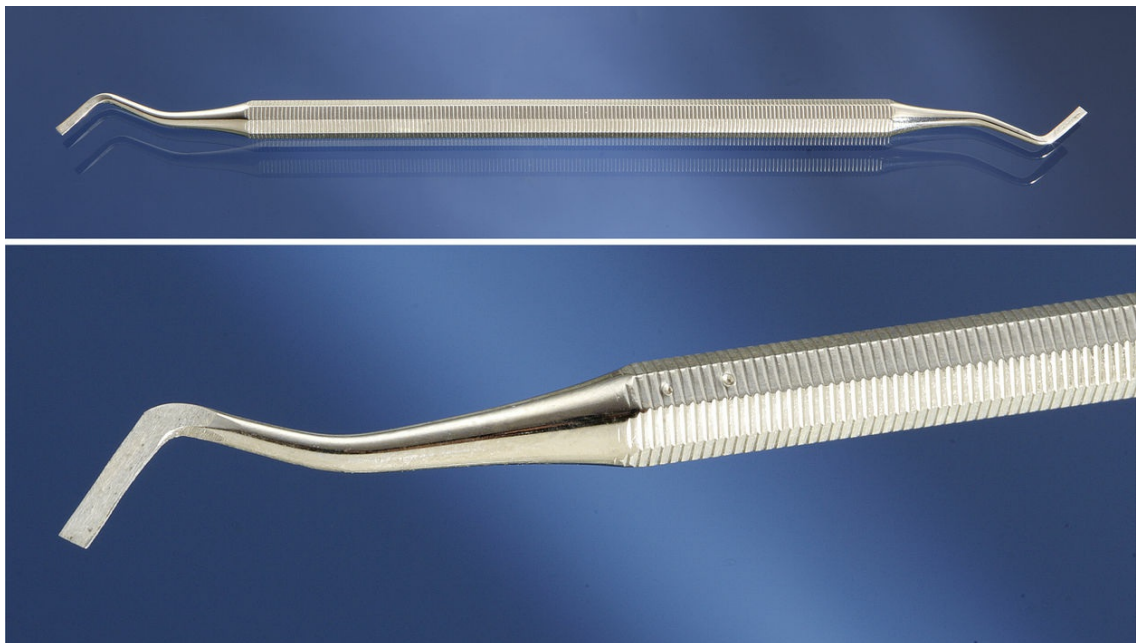

Instrument

Enamel Hatchet

Functions

To cut, clean, and smooth walls in cavity preparation
To remove enamel not supported by dentin

Characteristics

Used with push motion
Cutting edge on same plane as handle
Single or double ended
Is a three-numbered instrument

Examples of instrument numbers

20-9-14
15-8-14
15-8-12

Practice Notes

Enamel Hatchet is used on restorative tray setups.

Sterilization Notes

Enamel Hatchet must be precleaned, either, placed in a sterilizing pouch with an internal process indicator, sealed, then sterilized OR wrapped with an internal process indicator inside and secured on the outside with process indicator tape, then sterilized. Verify appropriate color change has been achieved in external process indicator immediately after removal from sterilizer then check internal process indicator before treatment. Refer to state regulations for any additional state requirements.

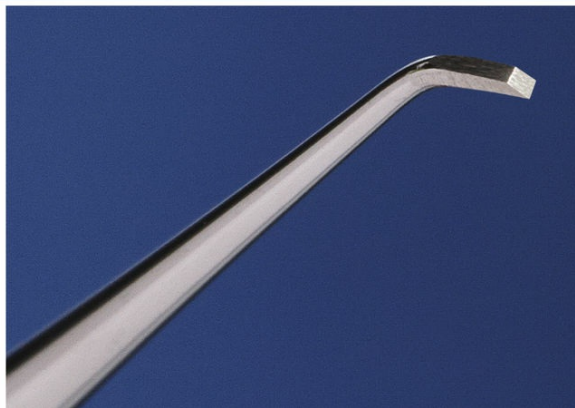
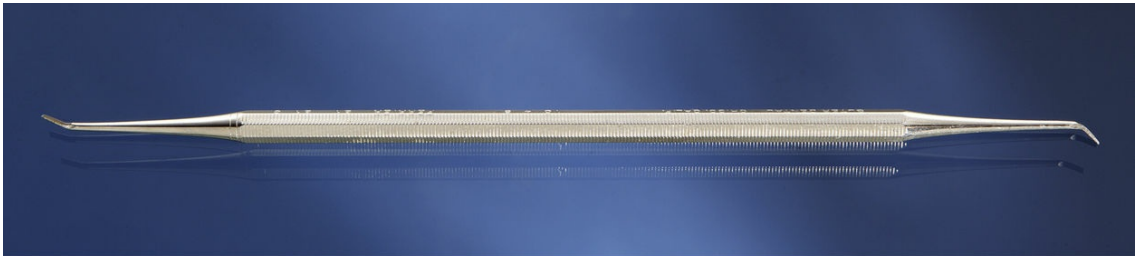
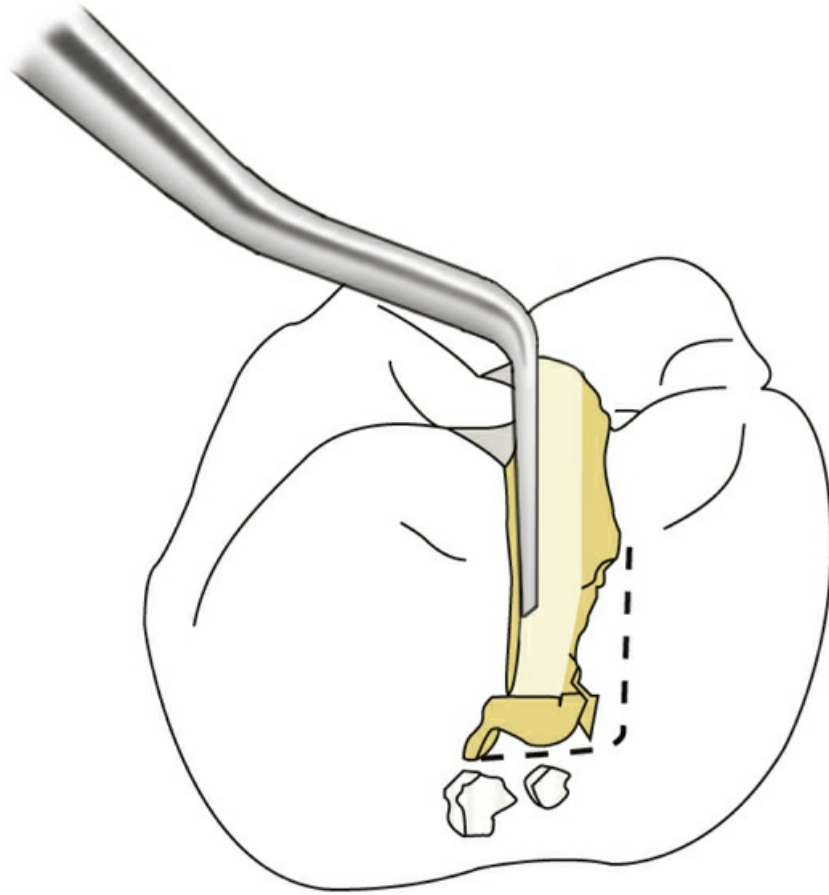

Instrument

Enamel Hoe

Function

To clean and smooth floor and walls in cavity preparation

Characteristics

Used with pulling motion

Cutting edge or blade nearly perpendicular to handle

Is a three-numbered instrument

Examples of instrument numbers

10-4-8

10-4-14

Practice Notes

Enamel Hoe is used on restorative tray setups.

Sterilization Notes

Enamel Hoe must be precleaned, either, placed in a sterilizing pouch with an internal process indicator, sealed, then sterilized OR wrapped with an internal process indicator inside and secured on the outside with process indicator tape, then sterilized. Verify appropriate color change has been achieved in external process indicator immediately after removal from sterilizer then check internal process indicator before treatment. Refer to state regulations for any additional state requirements.

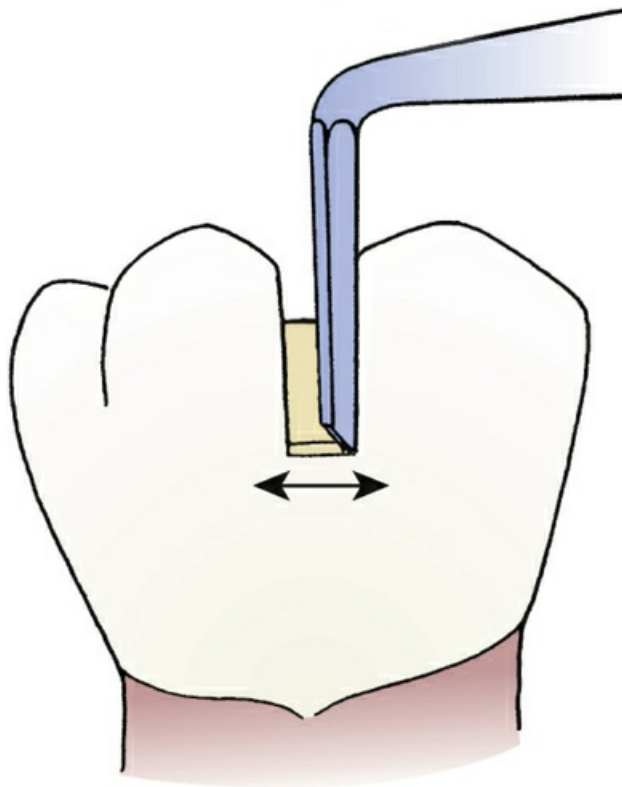

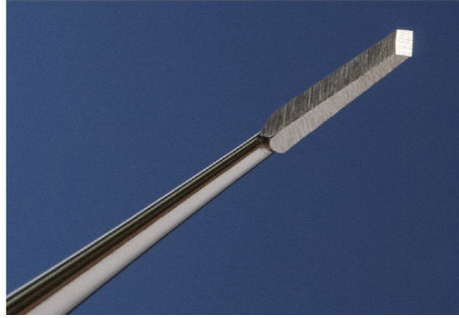

Instrument

Straight Chisel

Function

To plane and cleave enamel in cavity preparation

Characteristics

Used with push motion
Single-bevel cutting edge
Single or double ended

Examples of instrument numbers

15
20

Practice Notes

Straight Chisel is used on restorative tray setups.

Sterilization Notes

Straight Chisel must be precleaned, either, placed in a sterilizing pouch with an internal process indicator, sealed, then sterilized OR wrapped with an internal process indicator inside and secured on the outside with process indicator tape, then sterilized. Verify appropriate color change has been achieved in external process indicator immediately after removal from sterilizer then check internal process indicator before treatment. Refer to state regulations for any additional state requirements.

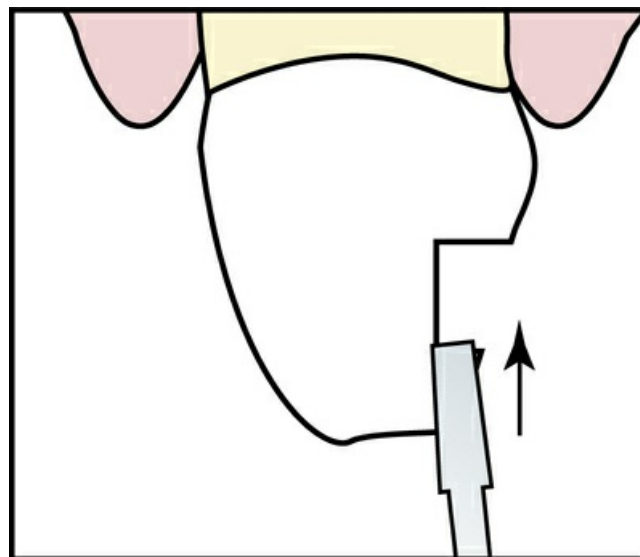

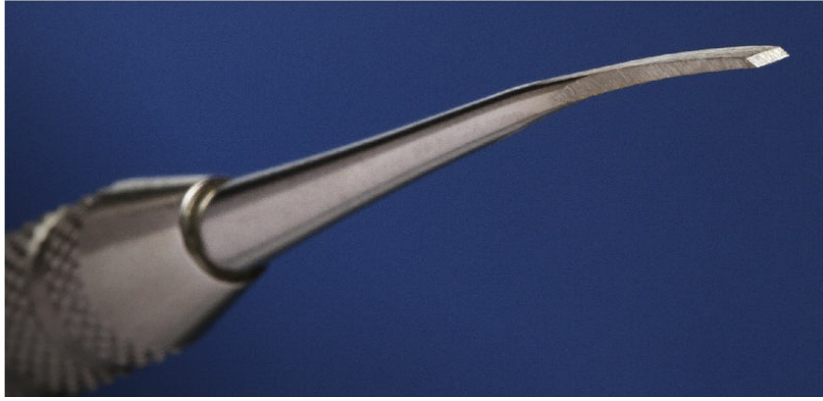

Instrument

Wedelstaedt Chisel

Function

To plane and cleave enamel in cavity preparation

Characteristics

Used with push motion
Curved blade on working end
Single-bevel cutting edge
Single or double ended
Is a three-numbered instrument

Examples of instrument numbers

15-15-3
11.5-15-3

Practice Notes

Wedelstaedt Chisel is used on restorative tray setups.

Sterilization Notes

Wedelstaedt Chisel must be precleaned, either, placed in a sterilizing pouch with an internal process indicator, sealed, then sterilized OR wrapped with an internal process indicator inside and secured on the outside with process indicator tape, then sterilized. Verify appropriate color change has been achieved in external process indicator immediately after removal from sterilizer then check internal process indicator before treatment. Refer to state regulations for any additional state requirements.

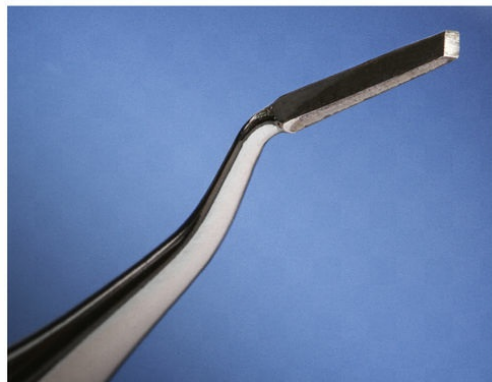
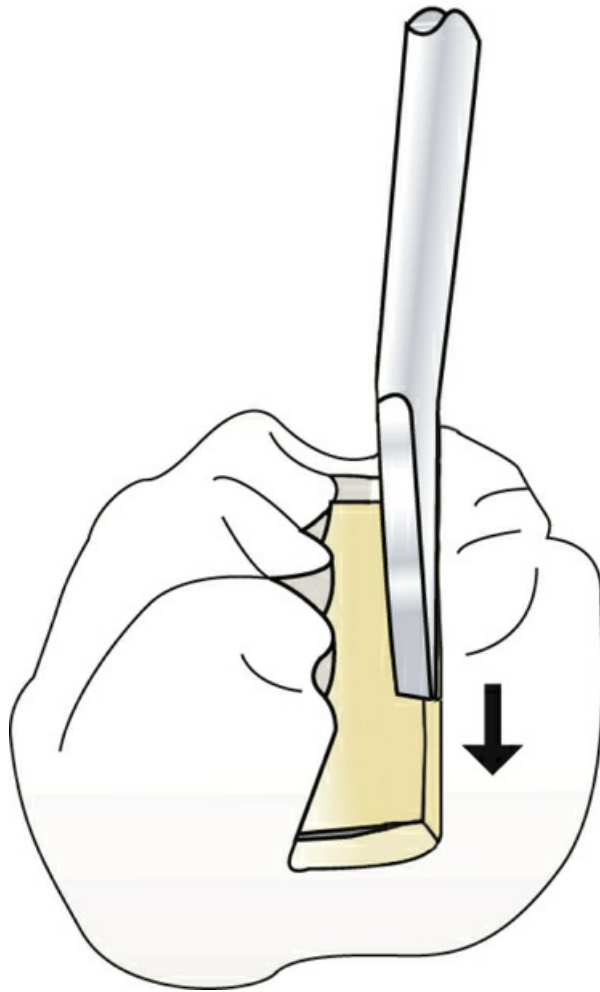

Instrument

Binangle Chisel

Function

To plane and cleave enamel in cavity preparation

Characteristics

Used with push motion
Two angles in the shank
Single or double ended
Is an example of three-numbered instrument

Examples of instrument numbers

20-9-8
15-8-8

Practice Notes

Binangle Chisel is used on restorative tray setups.

Sterilization Notes

Binangle Chisel must be precleaned, either, placed in a sterilizing pouch with an internal process indicator, sealed, then sterilized OR wrapped with an internal process indicator inside and secured on the outside with process indicator tape, then sterilized. Verify appropriate color change has been achieved in external process indicator immediately after removal from sterilizer then check internal process indicator before treatment. Refer to state regulations for any additional state requirements.

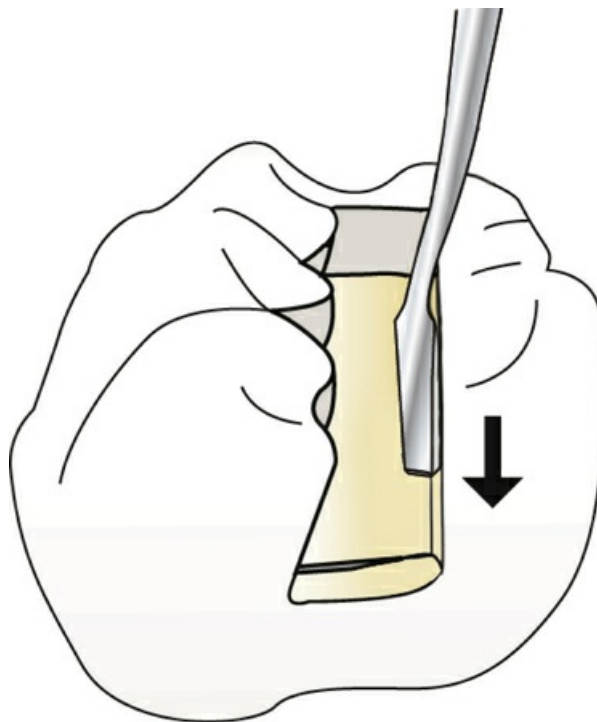



Instrument

Angle Former

Function

To accentuate line and point angles in internal outline and retention in cavity preparation

Characteristics

Cutting edge at an angle
Single or double ended
Is a four-numbered instrument

Examples of instrument numbers

12-80-5-8
9-80-4-8

Practice Notes

Angle Former is used on restorative tray setups.

Sterilization Notes

Angle Former must be precleaned, either, placed in a sterilizing pouch with an internal process indicator, sealed, then sterilized OR wrapped with an internal process indicator inside and secured on the outside with process indicator tape, then sterilized. Verify appropriate color change has been achieved in external process indicator immediately after removal from sterilizer then check internal process indicator before treatment. Refer to state regulations for any additional state requirements.



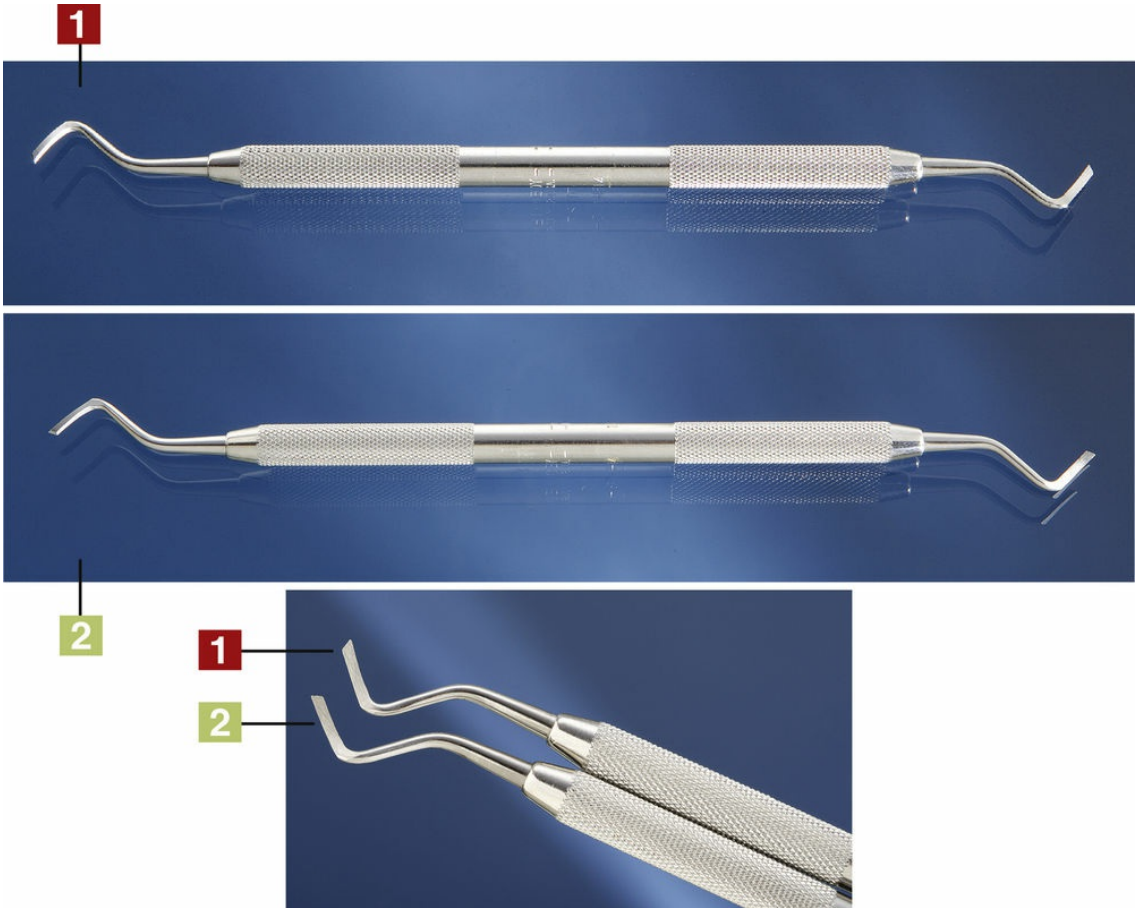

Instrument

Gingival Margin Trimmer—Mesial and Distal

Function

To bevel cervical walls of mesial and distal retention areas

Characteristics

- Mesial: To create bevels on the mesial cervical margin of the preparation
- Distal: To create bevels on the distal cervical margin of the preparation

Curved blade

Cutting edge at angle to blade

Double ended (one end curves to the right; the other to the left)

Is a four-numbered instrument

Examples of instrument numbers

Mesial: 13-80-8-14 or 15-80-8-12

Distal: 13-95-8-14 or 15-95-8-12

Practice Notes

Gingival Margin Trimmer is used on restorative tray setups.

Gingival Margin Trimmer is placed on tray setups in pairs: mesial and distal.

Refer to the amalgam tray setup in [Chapter 8](#).

Sterilization Notes

Gingival Margin Trimmer must be precleaned, either, placed in a sterilizing pouch with an internal process indicator, sealed, then sterilized OR wrapped with an internal process indicator inside and secured on the outside with process indicator tape, then sterilized. Verify appropriate color change has been achieved in external process indicator immediately after removal from sterilizer then check internal process indicator before treatment. Refer to state regulations for any additional state requirements.

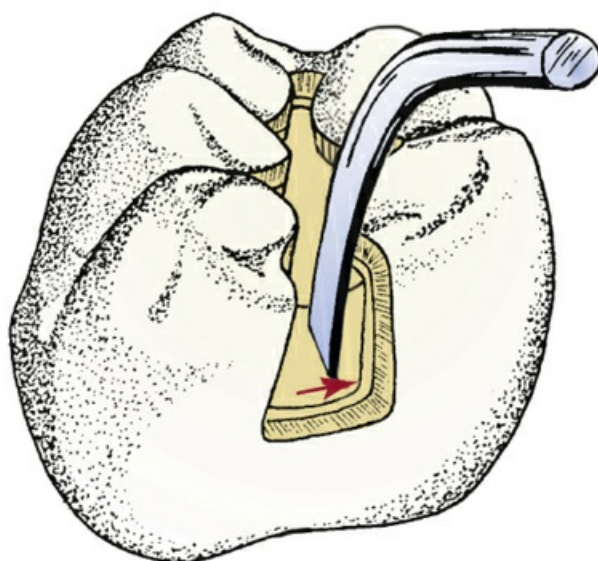

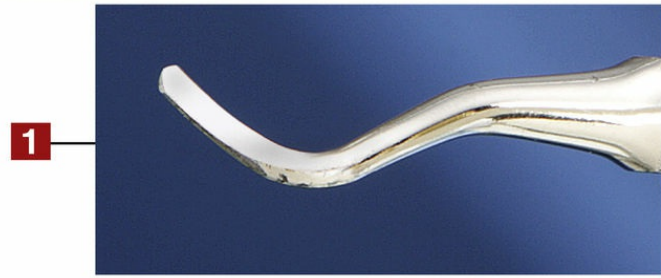

Instrument

Spoon Excavators

Function

To remove carious dentin
Secondary functions:
To remove temporary crowns
To remove temporary cement in temporary restoration
To remove permanent crown during try-in

Characteristics

Concave design, spoon-shaped with cutting edge
Range of sizes:
■ Large—Curved blade—also referred to as Black Spoon
■ Small—Round blade
Single or double ended

Practice Notes

Spoon Excavator is used on restorative tray setups.
Refer to the amalgam tray setup (see [Chapter 8](#)), composite tray setups (see [Chapter 9](#)), and crown and bridge restorative tray setups (see [Chapter 10](#)).

Sterilization Notes

Spoon Excavator must be precleaned, either, placed in a sterilizing pouch with an internal process indicator, sealed, then sterilized OR wrapped with an internal process indicator inside and secured on the outside with process indicator tape, then sterilized. Verify appropriate color change has been achieved in external process indicator immediately after removal from sterilizer then check internal process indicator before treatment. Refer to state regulations for any additional state requirements.

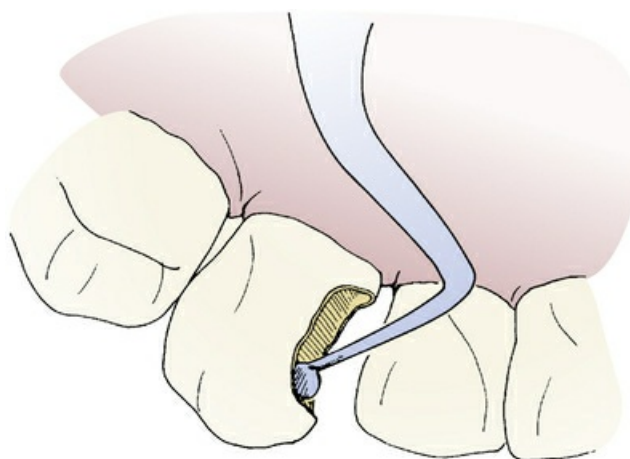

* The instrument number formula was designed by Dr. G.V. Black, Northwestern University.

* The instrument number formula was designed by Dr. G.V. Black, Northwestern University.

Local Anesthetic Syringe/Components and Nitrous Oxide Sedation

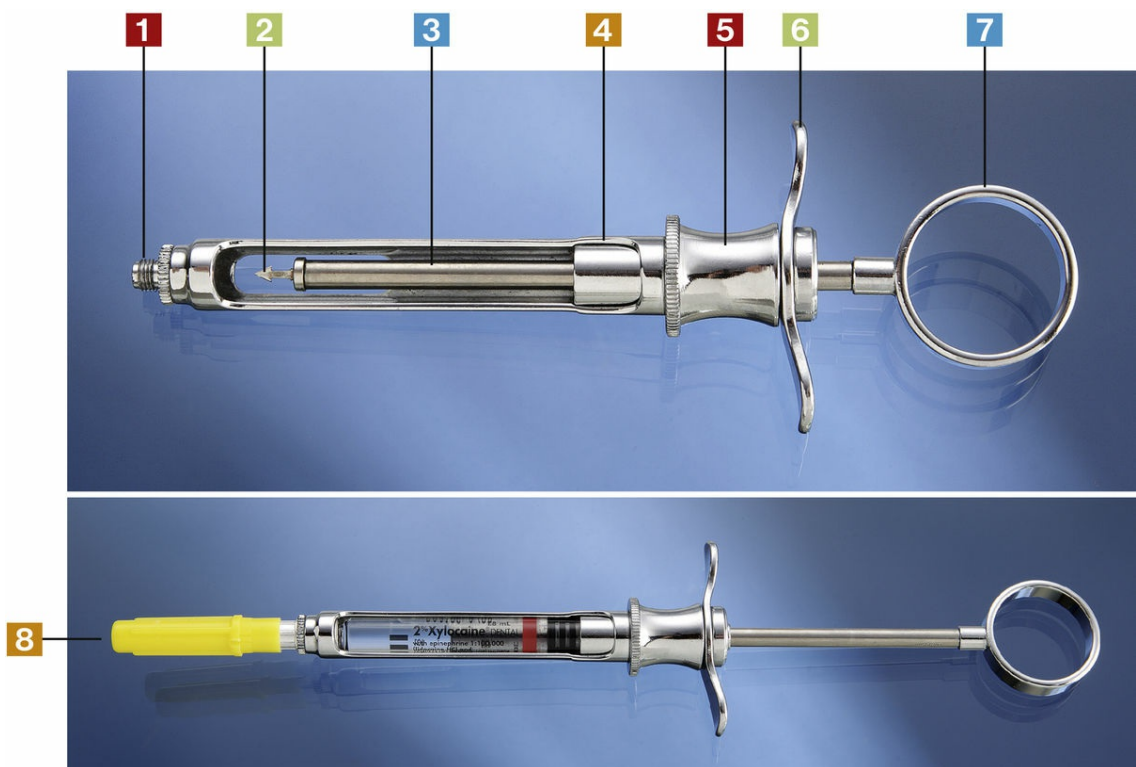
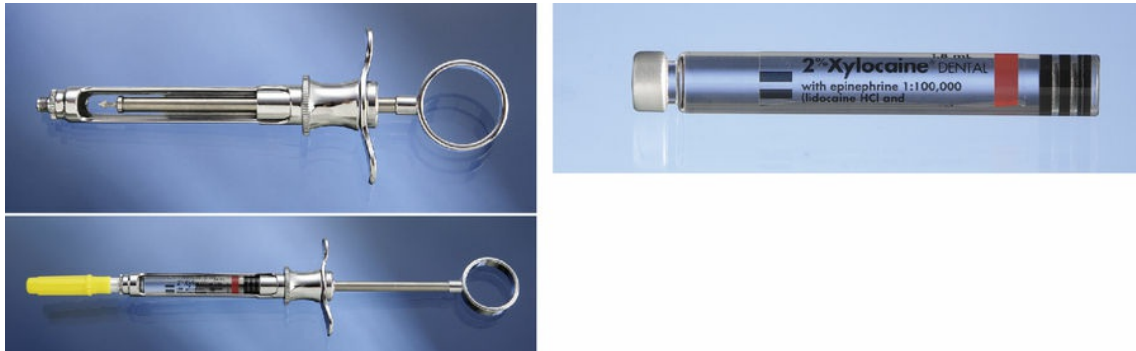

Instrument

Anesthetic Aspirating Syringe

Function

To administer a local anesthetic

Characteristics

Parts:

- Threaded tip
- Harpoon
- Piston rod
- Barrel of syringe
- Finger grip
- Finger bar
- Thumb ring
- Syringe assembled with needle and anesthetic cartridge

Practice Notes

Syringes with harpoons are considered aspirating syringes.

Disposable syringes equipped with needles and preloaded with anesthetic are available.

Anesthetic Aspirating Syringe is used on most tray setups.

Sterilization Notes

Anesthetic Aspirating Syringe must be precleaned, either, placed in a sterilizing pouch with an internal process indicator, sealed, then sterilized OR wrapped with an internal process indicator inside and secured on the outside with process indicator tape, then sterilized. Verify appropriate color change has been achieved in external process indicator immediately after removal from sterilizer then check internal process indicator before treatment. Refer to state regulations for any additional state requirements. Disposable preloaded syringes with needle must be disposed of in a sharps container. Anesthetic cartridge and needle must be disposed of in a sharps container. Refer to local and state recommendations for disposal of anesthetic cartridge.



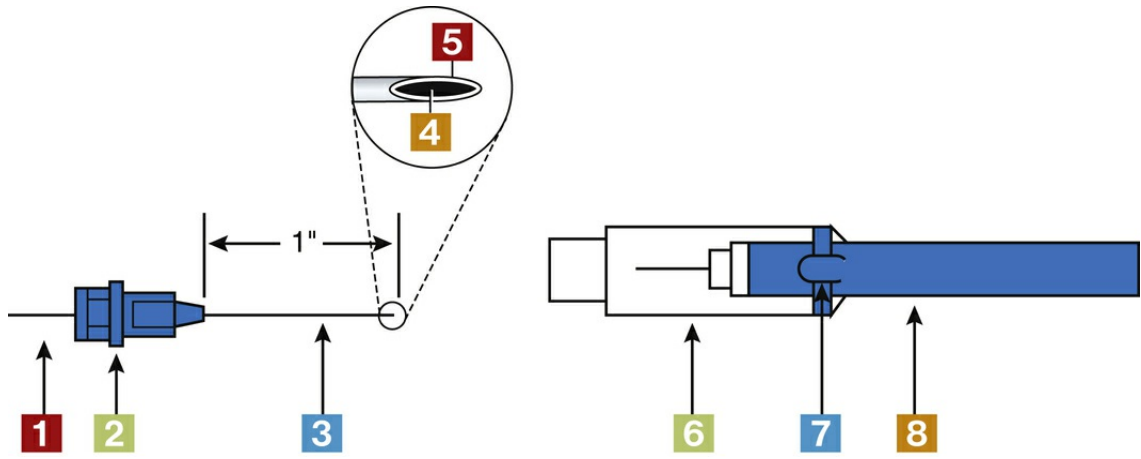

Instrument

Short Needle

Function

To administer anesthetic by infiltration injection on maxillary arch

Characteristics

Parts:

- Cartridge end of needle
- Needle hub
- Injection end of needle
- Lumen of the needle
- Bevel of the needle
- Protective cap
- Seal on cap
- Needle guard

1 inch long for infiltration injection

- End of needle inserts into the anesthetic cartridge
- Anesthetic solution is ejected through the lumen of the needle

Variety of gauges:

- Gauge number—Identifies diameter (thickness) of needle
- Larger gauge number—Indicates thinner needle (e.g., 30 gauge is thinner than 25 gauge)

Practice Notes

Local anesthetic syringe setup is used on most tray setups

Sterilization Notes

Short Needle must be disposed of in a sharps container. Single use only.

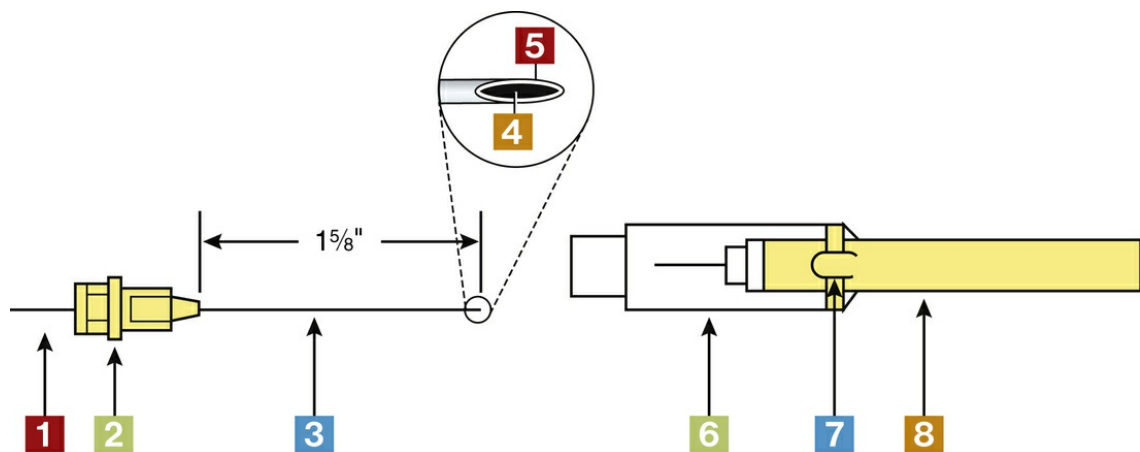

Instrument

Long Needle

Function

To administer anesthetic by block injection on mandibular arch

Characteristics

Parts:

- Cartridge end of needle
- Needle hub
- Injection end of needle
- Lumen of the needle
- Bevel of the needle
- Protective cap
- Seal on cap
- Needle guard

1 $\frac{5}{8}$ inches long for block injection

- End of needle inserts into the anesthetic cartridge
- Anesthetic solution is ejected through the lumen of the needle

Variety of gauges:

- Gauge number—Identifies diameter (thickness) of needle
- Larger gauge number—Indicates thinner needle (e.g., 30 gauge is thinner than 25 gauge)

Practice Notes

Local anesthetic syringe setup is used on most tray setups.

Sterilization Notes

Long Needle must be disposed of in a sharps container. Single use only.

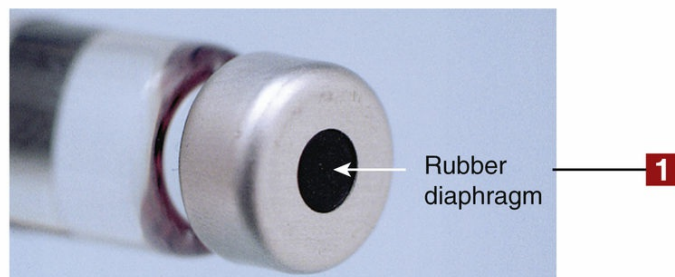
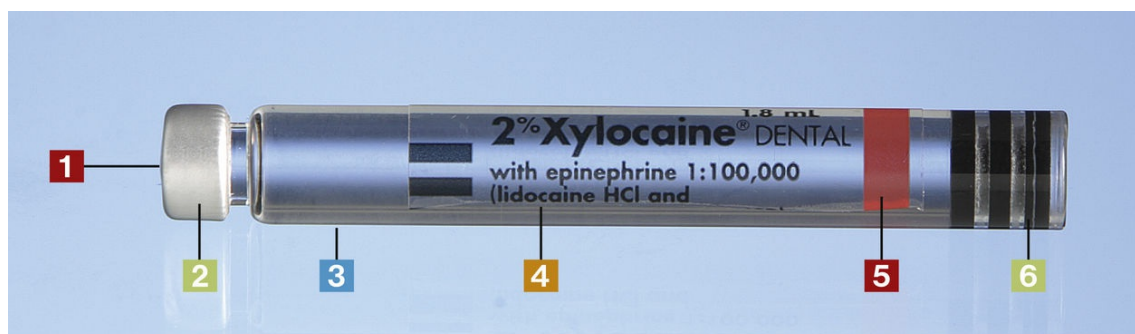

Instrument

Anesthetic Cartridge

Function

To hold liquid anesthetic for local injection in the oral cavity

Characteristics

Parts:

- Rubber diaphragm—Syringe needle is inserted into the diaphragm to penetrate into the cartridge.
- Aluminum cap holds the rubber diaphragm in place.
- Glass cartridge (also referred to as a carpule)
- Indicates type of anesthesia
- Color-coded band indicating type of anesthetic (required by the American Dental Association, June 2003)
- Silicon rubber plunger—Harpoon of syringe inserts into silicon rubber plunger.

Composition of solution in cartridge—Contains 1.7 to 1.8 mL of anesthetic solution

Plunger slightly indented from rim of glass

Practice Notes

Type of anesthetic used depends on patient's health history and dental procedure performed. Local anesthetic syringe setup is used on most tray setups.

Sterilization Notes

Anesthetic Cartridge must be disposed of in a sharps container. Refer to local and state recommendations for disposal of cartridge. Single use only.



Instrument

Anesthetic Cartridges/Blister Packs

Function

To hold liquid anesthetic for injection

Characteristics

Several types of anesthetic solutions available

Each cartridge is labeled.

Color code system on cartridge—Identifies type of anesthetic (required by the American Dental Association, June 2003). Color band on each cartridge indicates type of anesthetic solution.

Type of anesthetic used depends on patient's health history and dental procedure performed:

- Anesthetic is available without a vasoconstrictor.
- Ratio of epinephrine: the lower the second number, the higher the percentage of vasoconstrictor. Information printed on cartridge. Example of common anesthetic for routine dental procedures 1:100,000.
- Longer lasting anesthetic has a higher percentage of vasoconstrictor. Example: 1:50,000.

Practice Notes

Remove each cartridge from blister pack as needed for each procedure and place cartridge on tray setup.

Local anesthetic syringe setup is used on most tray setups.

Sterilization Notes

Anesthetic Cartridge must be disposed of in a sharps container. Refer to local and state recommendations for disposal of cartridge. Each anesthetic cartridge for single use only.



Instrument

Recapping Device

Function

To hold needle sheath for one-hand recapping after injection

Characteristics

- Jenker—Low center of gravity for stability in recapping
- Needle cap holder attached to cassette

Helps prevent needle stick accidents

Different styles of needle stick protectors available

Practice Notes

Needle Stick Protector is used on most tray setups.

Scoop Technique Procedure—Recap needle by scooping end of needle into needle guard (not shown).

Sterilization Notes

Needle Stick Protector—Jenker or needle cap holder must be precleaned, either, placed in a sterilizing pouch with an internal process indicator, sealed, then sterilized OR wrapped with an internal process indicator inside and secured on the outside with process indicator tape, then sterilized. Verify appropriate color change has been achieved in external process indicator immediately after removal from sterilizer then check internal process indicator before treatment. Refer to state regulations for any additional state requirements. Disposable preloaded syringes with needle must be disposed of in a sharps container. Anesthetic cartridge and needle must be disposed of in a sharps container. Refer to local and state recommendations for disposal of anesthetic cartridge.





Instrument

Computer-Controlled Local Anesthetic Delivery System (The Wand/STA Single Tooth Anesthesia System)

Functions

To administer a local anesthetic
To improve ergonomics and precision of dental anesthetic delivery

Characteristics

Lightweight wand handpiece held in a penlike grip.
Presterilized bonded handpiece (not a traditional dental syringe)
Foot-activated control delivers local anesthetic.
Computer controls available flow rates of local anesthetic, making them consistent.
Aspiration test can be activated at any time by releasing the pressure cycle on the foot rheostat.
Can be used for all dental injections and intraligamentary (PDL) injection

Practice Notes

The operator focuses on needle insertion and positioning while the motor in the device administers the drug at a preprogrammed rate of flow.
Increased tactile control and ergonomics decreases patient discomfort.

Sterilization Notes

Anesthetic cartridge must be disposed of in a biohazard container. Refer to local and state recommendations for disposal of cartridge. Single use only. Needle must be disposed of in a sharps container. Single use only. Tubing must be disposed of in garbage. One time use only. Refer to manufacturer's recommendation for disinfection of unit.



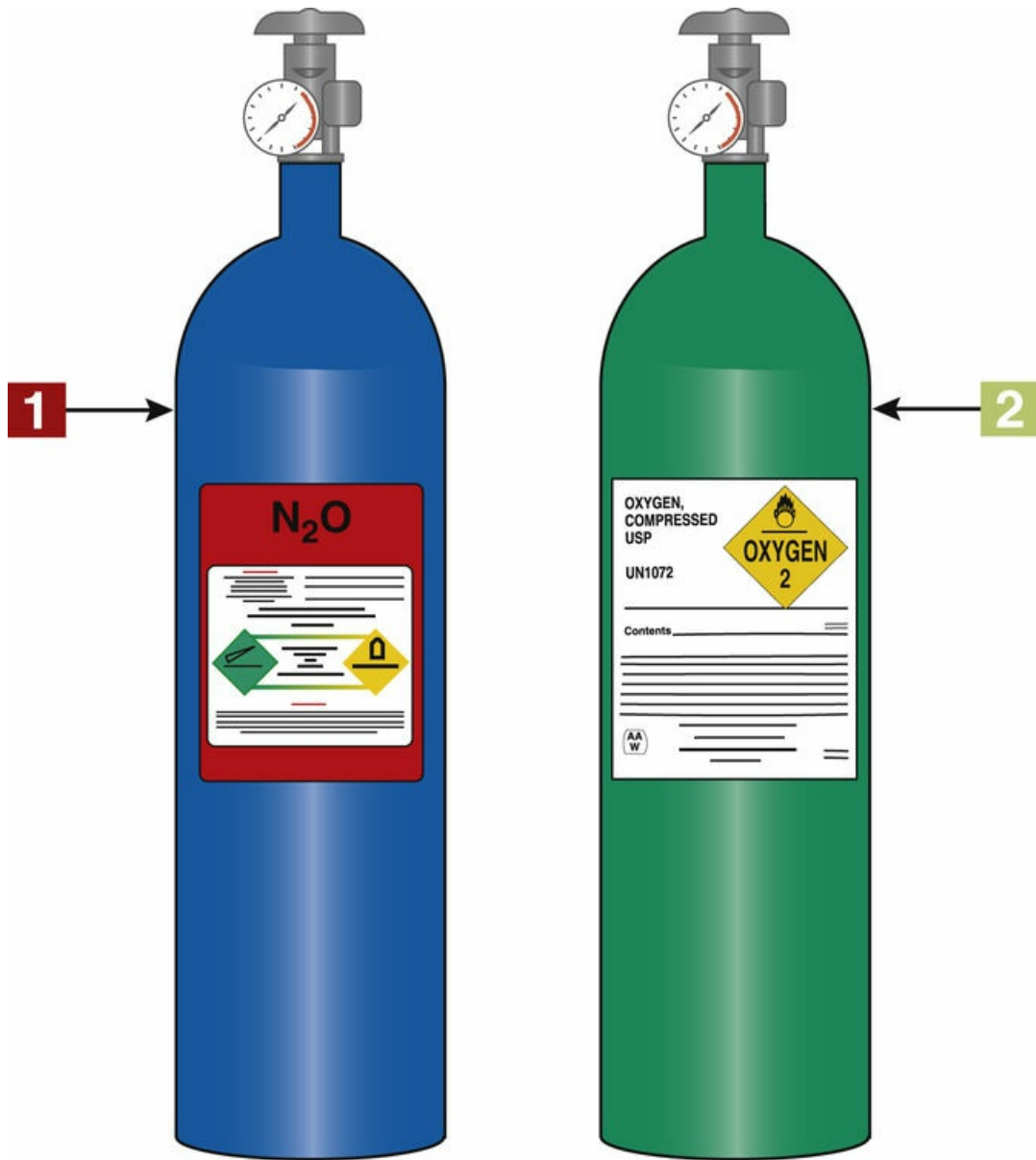

Instrument

Nitrous Oxide and Analgesic Tanks

Function

To use as an analgesic to relax patients for dental procedures
To be inhaled through a mask placed over the nose

Characteristic

- Blue tank is N₂O
- Green tank is O₂

Nitrous oxide is a chemical compound with the formula N₂O. It is an oxide of nitrogen. Room temperature, N₂O is a colorless, nonflammable gas, with a slightly sweet odor and taste
Nose piece has tubing attached to a scavenger system that evacuates excess N₂O that patient does not breath.

Practice Notes

Nitrous oxide is used for apprehensive patients for all types of dental procedures.

Oxygen must be given to patient before dismissing from the dental chair.

Fail-safe system:

All N₂O and O₂ systems used in dentistry have a fail-safe system.

Sufficient amount of O₂ gas must be present in the tank while system is functioning or the system will shut down.

Sterilization Notes

Nitrous Oxide Tanks—refer to manufacturer’s recommendation for disinfection.



Instrument

Nitrous Oxide Nasal Mask

Functions

To place mask over the patient's nose for the delivery of N₂O
To evacuate excess N₂O that is not breathed in by the patient

Characteristics

- Tubing for N₂O
 - Tubing for scavenger system to evacuate excess N₂O
 - Disposable masks available in different scents
- Different size masks available for children and adults.

Practice Notes

Gauze is placed under mask for patient comfort. N₂O is used for apprehensive patients for all types of dental procedures.
Oxygen must be given to the patient before dismissing the patient from the dental chair.

Sterilization Notes

N₂O Masks refer to manufacturer's recommendation for sterilization. Disposable masks single use only. Dispose of in the garbage.





Instrument

Nitrous Oxide and Oxygen Flowmeters

Function

To monitor the N₂O and O₂ that is administered to the patient

Characteristics

- % N₂O adjustment knob: Controls the % of N₂O
- Total flow adjustment knob: Controls the combined flow of O₂ and N₂O or O₂ flow only when the % of N₂O knob is set to zero
- Digital display readout of N₂O and O₂ using knobs for adjustment of gas flow.

Tubing from the tanks go to flowmeters and tubing from flowmeters go to the face mask that delivers the gases to the patient.

All masks have tubing attached to a scavenger system: An appropriate evacuation/HVE system that evacuates the excess gas that the patient does not inhale.

Practice Notes

N₂O is used for apprehensive patients for all types of dental procedures.

Oxygen must be given to the patient before dismissing from the dental chair.

Sterilization Notes

Flowmeters refer to manufacturer's recommendation for disinfection.



Tray Setup

Local Anesthetic Syringe

From Left to Right

Anesthetic aspirating syringe, long needle, short needle, anesthetic cartridges, needle stick protector (Jenker) (top right), individually packed topical anesthetic (bottom right)

Practice Notes

Local Anesthetic Syringe setup is found on most tray setups.

Sterilization Notes

Anesthetic Syringe and Needle Stick Protector must be precleaned, either, placed in a sterilizing pouch with an internal process indicator, sealed, then sterilized OR wrapped with an internal process indicator inside and secured on the outside with process indicator tape, then sterilized. Verify appropriate color change has been achieved in external process indicator immediately after removal from sterilizer then check internal process indicator before treatment. Refer to state regulations for any additional state requirements. Anesthetic cartridge and needle must be disposed of in a Sharps container. Refer to local and state recommendations for disposal of anesthetic cartridge. Dispose of topical in garbage. Single use only.

Evacuation Devices, Air/Water Syringe Tip, and Dental Unit

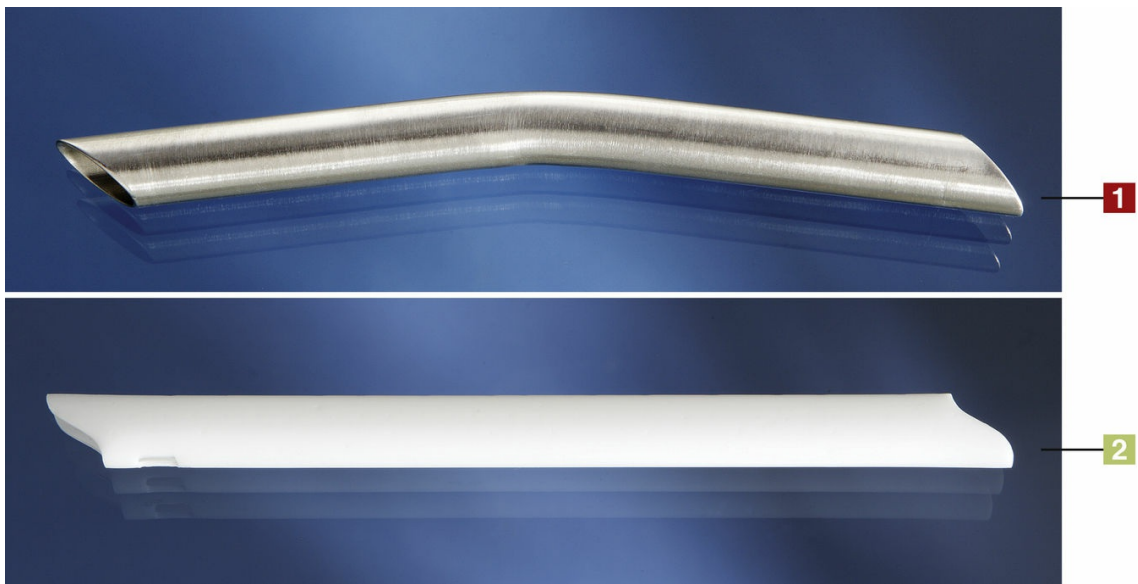

Instrument

High-Volume (Velocity) Evacuator (HVE) Tip

Function

To evacuate large volumes of fluid and debris from the oral cavity

Characteristics

- Stainless steel evacuator tip
 - Plastic evacuator tip— Disposable plastic
- Straight or slightly angled at one or both ends
Also available in plastic that may be sterilized

Practice Notes

Evacuator Tip attaches to high-velocity tubing on dental unit.
HVE Tip is used on most tray setups.

Sterilization Notes

HVE Tip must be precleaned, either, placed in a sterilizing pouch with an internal process indicator, sealed, then sterilized OR wrapped with an internal process indicator inside and secured on the outside with process indicator tape, then sterilized. Verify appropriate color change has been achieved in external process indicator immediately after removal from sterilizer then check internal process indicator before treatment. Refer to state regulations for any additional state requirements. Disposable plastic HVE tip should be disposed of in the garbage.



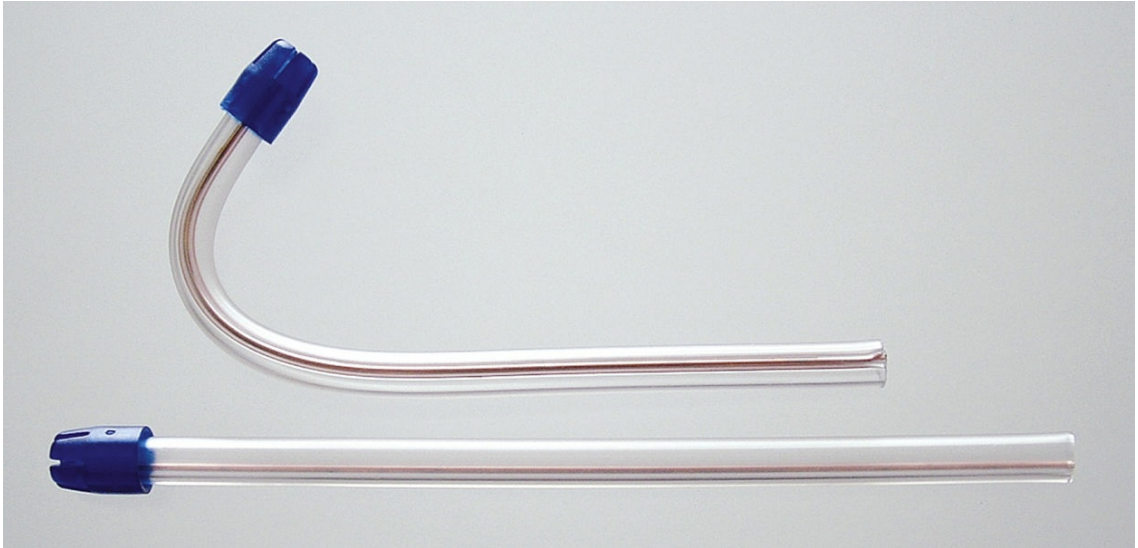

Instrument

Low-Volume (Velocity) Saliva Ejector Tip

Function

To evacuate smaller volumes of fluid from the oral cavity

Characteristics

Disposable plastic for single use only

Can be bent for placement under tongue and in other areas of mouth or can be used straight

Variety of styles

Practice Notes

Attaches to low-velocity tubing on dental unit

Saliva Ejector Tip is used on most tray setups.

Sterilization Notes

Disposable Saliva Ejector Tip should be disposed of in the garbage. Single use only. Refer to the Centers for Disease Control and Prevention (CDC) guidelines regarding possible backflow from low-volume saliva ejectors.



Instrument

Isolite®—Illuminated Dental Isolation System

Functions

- To retract tongue and evacuate fluid from patient's mouth
- To provide light to the working area of the mouth
- To gently hold patient's mouth open during use
- To serve as a barrier to the airway, protecting the patient from inadvertent aspiration of dental material

Characteristics

Isolite is attached to high-velocity evacuation port of the vacuum system. No special devices are required to operate system installed on the dental unit.

Practice Notes

- Isolates two quadrants at once on the same side
- Used for maxillary and mandibular procedures
- Light settings for light-sensitive curing material

Sterilization Notes

Please follow manufacturer's instructions for cleaning and sterilization. Applicable components should be placed in sterilization pouch/bag and sealed or wrapped and secured with processing indicating tape, then sterilized. An internal processing indicator should be included with each sterilization pouch and/or wrap. When an internal processing indicator is not visible, then an external processing indicator should be placed on the outside of the packaging. Indicators should be checked immediately upon removal from sterilizer to verify the appropriate color change has been achieved. Refer to state regulations for any additional state requirements. Disposable plastic should be disposed of in the garbage. Single use only. Refer to manufacturer's recommendation and the CDC guidelines.





Instrument

Low-Volume (Velocity) Mandibular Evacuator

Functions

- To evacuate smaller volumes of fluid from the oral cavity
- To use on mandibular arch
- To retract tongue during evacuation

Characteristics

- Blade for retraction of tongue is covered for patient comfort
 - Adjustable device to place under patient's chin to hold evacuator in place
- Disposable plastic for single use only (may be referred to as a Linqua-fix)
Also available in metal, referred to as a Svedopter, must be sterilized

Practice Notes

- Attaches to low-velocity tubing on dental unit
- Disposable Low-Volume Mandibular Evacuator is used on sealant tray setups and on procedures for mandibular arch when operator is working without an assistant.
- Disposable Low-Volume Mandibular Evacuator (pictured) should be disposed of in the garbage.

Sterilization Notes

Disposable Low-Volume Mandibular Evacuator should be disposed of in the garbage. Single use only. Svedopter (metal evacuator—not shown) must be precleaned, either, placed in a sterilizing pouch with an internal process indicator, sealed, then sterilized OR wrapped with an internal process indicator inside and secured on the outside with process indicator tape, then sterilized. Verify appropriate color change has been achieved in external process indicator immediately after removal from sterilizer then check internal process indicator before treatment. Refer to state regulations for any additional state requirements.



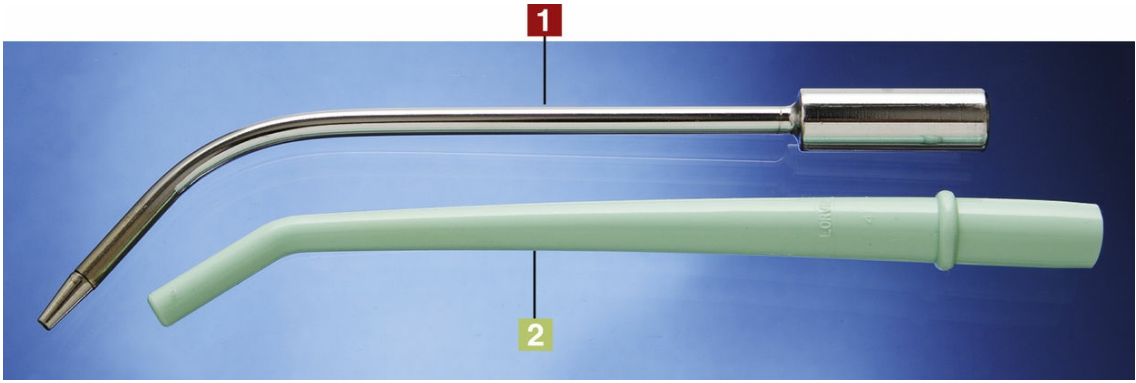

Instrument

High-Volume (Velocity) Surgical Evacuation Tip

Function

To evacuate fluid from oral cavity and surgical site

Characteristics

Stainless steel, autoclavable plastic, disposable plastic:

- Stainless steel evacuation tip
- Plastic disposable tip

Narrowed tip accommodates surgical site.

Practice Notes

Surgical evacuation tip attaches to high-velocity tubing on dental unit.

May require connecting tube for adaptation to surgical evacuation tip

Some stainless steel surgical tips narrow at insertion of tubing; additional tubing is necessary to connect to high-velocity tubing on dental unit.

Surgical Evacuation Tip is used on most surgical tray setups.

Sterilization Notes

Surgical (Metal) Evacuation Tips must be precleaned, either, placed in a sterilizing pouch with an internal process indicator, sealed, then sterilized OR wrapped with an internal process indicator inside and secured on the outside with process indicator tape, then sterilized. Verify appropriate color change has been achieved in external process indicator immediately after removal from sterilizer then check internal process indicator before treatment. Refer to state regulations for any additional state requirements. Disposable Surgical Evacuation Tip should be disposed of in the garbage. Single use only.



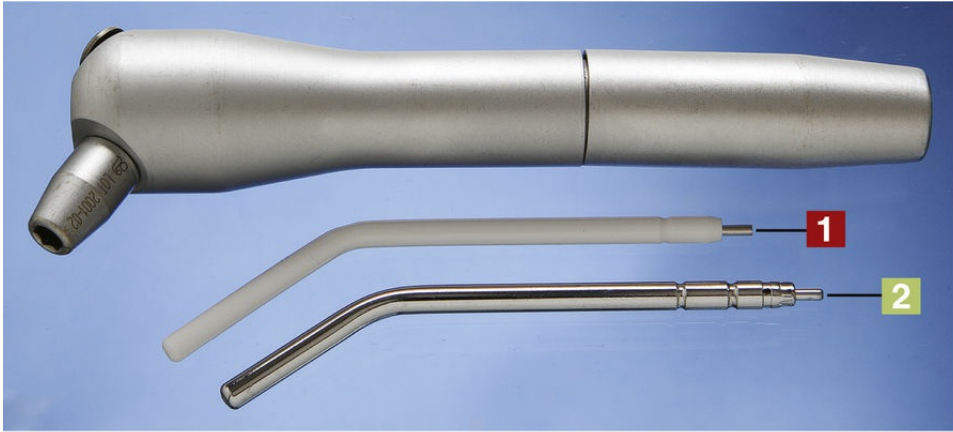

Instrument

Air/Water Syringe with Removable Tip

Function

To rinse and dry specific teeth or entire oral cavity

Characteristics

Air/water syringe is also referred to as a three-way syringe.

Characteristics of buttons on air/water syringe: left button expels water only; right button expels air only; pressing both buttons at the same time will result in a spray by combining air and water.

Types of tips:

- Disposable plastic syringe tip for single use
- Metal syringe tip
- Seal-Tight tip seals water passage from getting into the air passage of the tip

Practice Notes

Syringe Tip—Attaches to air/water syringe

Air/Water Syringe—Attaches to tubing on dental unit

Sterilization Notes

Metal Air/Water Syringe Tip must be precleaned, either, placed in a sterilizing pouch with an internal process indicator, sealed, then sterilized OR wrapped with an internal process indicator inside and secured on the outside with process indicator tape, then sterilized. Verify appropriate color change has been achieved in external process indicator immediately after removal from sterilizer then check internal process indicator before treatment. Refer to state regulations for any additional state requirements. Disposable air/water syringe tip should be disposed of in the garbage. Single use only. Air/water syringe that tip is attached to must be disinfected according to manufacturer's recommendation.





Instrument

Self-Contained Water Unit and Waterline Treatment Tablets

Functions

To assist in the quality of water entering the dental unit that supplies water to handpieces, air/water syringe, and cuspidor cupfill

To assist when there is a possibility of contamination to the water supply to the dental unit

Characteristics

Water system may be mounted in different areas of the dental unit.

Different size bottles are available.

Example

7 L or 2 L

- Self-contained water bottle attached to dental unit
- Tablets—Place tablets in each water bottle every time bottle is filled.

Reduces accumulation of contaminants

Reduces accumulation of order and foul-tasting bacteria

Practice Notes

Follow manufacturer's recommendations for periodic shock treatment of water lines using special tablets; safety precautions while using tablets and filling bottles.

Sterilization Notes

CDC recommends monitoring dental unit water regularly. Example weekly testing of water either in office or commercial monitoring system (Guidelines for Infection Control in Dental Health Care Setting, 2003).



Instrument

Dental Delivery System

Function

To deliver dental care to patients

Characteristics

- Ergonomically structured chair for patient, operator, and assistant
- Chair adjustment device for height and reclining patient
- Light with adjustable intensity - LED light with curing option for composite restorations
- Tubing for high and slow speed handpieces, air/water syringe, low- and high-velocity vacuum systems
- Rheostat for running handpieces with water toggle switch option
- Tray for placing instrument setups
- Computer screen available for patient information and digital images

Practice Notes

Many different designs of dental delivery systems available

Air/water syringes available on one or both sides of operator or assistant's side

Evacuation tubing on assistant's side of patient chair

Tubing for handpieces available on operator or assistant's side of patient chair

Sterilization Notes

Refer to manufacturing and CDC guidelines on purging dental lines (tubing), disinfecting chair, tubing, and dental unit.



Instrument

Dental Assistant Delivery System

Function

To deliver dental care to patients as a chairside assistant

Characteristics

- Saliva ejector attached to the low-volume evacuation system tubing
- Air/water syringe and tip attached to the tubing
- High-volume evacuator tip attached to the tubing
- Light curing device attached to the unit with protective shield
- Bracket table for instrument setups
- Chair adjustment device for height and reclining dental chair

Practice Notes

Many different designs of dental delivery systems are available. Dental assistant delivery system is used to deliver dental care to patients.

Sterilization Notes

Refer to manufacturing and CDC guidelines on purging dental lines (tubing), tubing, and disinfecting delivery system.



Instrument

Dental Stools

Function

To use providing treatment to a patient

Characteristics

- Operator chair—adjustable back support is movable forward and backward
- Operator and Assistant chair—adjustable seat height
- Adjustable torso support
- Assistant chair—adjustable foot ring under seat for feet support

Practice Notes

Operator chair—Feet recommended to be placed flat on floor for ergonomically correct position
Assistant chair—Feet recommended to be place on ring, bar underneath rib cage; while seated in the chair the assistant should be 4 to 6 inches above operator for ergonomically correct position.

Sterilization Notes

Chairs must be disinfected (including the height adjustment lever) after each patient; refer to manufacturer’s recommendation for disinfection of chairs.

Dental Handpieces



1

2

3

Instrument

High-Speed Handpiece

Functions

To use with bur to cut tooth structure, to cut bone, to remove decay, and to modify or remove restorations

Example

Cavity preparation for restoration or crown

To use with bur for adjusting crowns and bridges for final fit

Characteristics

Handpiece is run by air pressure at a maximum speed of 450,000 rotations per minute (rpm).

On high-speed handpiece, bur generates extreme amount of heat.

Instrument sprays water/air or air on bur for cooling purposes to prevent damage to pulp.

Different styles of securing bur are available:

- Power lever chuck
- Push-button chuck
- Conventional chuck—Need to secure bur and loosen bur in handpiece with wrench

Practice Notes

Handpiece attaches to tubing on dental unit.

Sterilization Notes

Most High-Speed Handpiece must be lubricated and precleaned according to the manufacturer's recommendation. Then, either, placed in a sterilizing pouch with an internal process indicator, sealed, then sterilized OR wrapped with an internal process indicator inside and secured on the outside with process indicator tape, then sterilized. Verify appropriate color change has been achieved in external process indicator immediately after removal from sterilizer then check internal process indicator before treatment. Refer to state regulations for any additional state requirements.





Instrument

Fiberoptic High-Speed Handpiece

Functions

- To illuminate tooth during preparation for restoration
- To provide light intraorally during use of handpiece
- To use with bur to cut tooth structure, to cut bone, to remove decay, and to modify or remove restorations

Example

- Cavity preparation for restoration or crown
- To use with bur for adjusting crowns and bridges for final fit

Characteristics

- Light(s) at head of handpiece
- Lights up working area while handpiece rotates
- Same characteristics as high-speed handpiece

Practice Notes

- Handpiece attaches to tubing on dental unit.
- Tubing has special adaptor for light availability.

Sterilization Notes

Most fiberoptic High-Speed Handpiece must be lubricated and precleaned according to the manufacturer's recommendation. Then, must be either, placed in a sterilizing pouch with an internal process indicator, sealed, then sterilized OR wrapped with an internal process indicator inside and secured on the outside with process indicator tape, then sterilized. Verify appropriate color change has been achieved in external process indicator immediately after removal from sterilizer then check internal process indicator before treatment. Refer to state regulations for any additional state requirements.



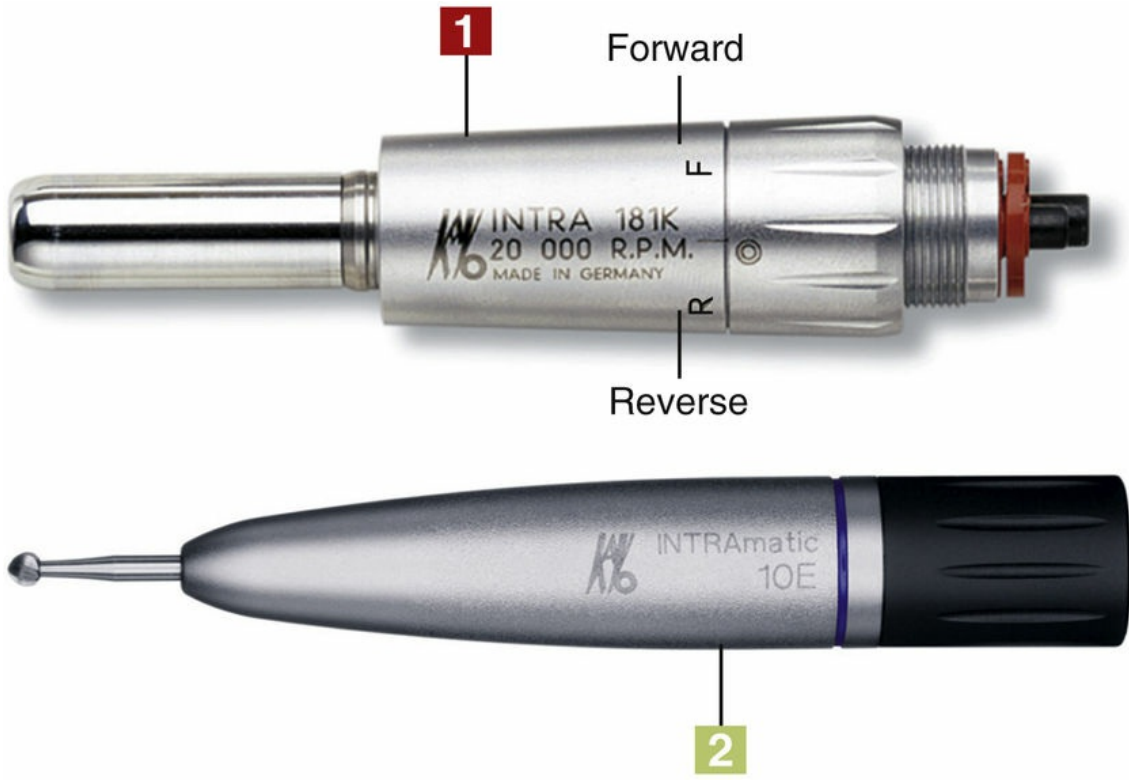

Instrument

Slow-Speed Motor with Straight Handpiece Attachment

Functions

To use with slow-speed attachments
To use straight attachment with long-shank straight bur

Characteristics

- Slow-speed motor
- Straight handpiece attachment (with bur attached)

Maximum speed of 30,000 rpm; used as adjunct to high-speed handpiece

Straight attachment—Used outside oral cavity, usually in a laboratory setting

Contra-angle or prophy angle attachments—Designed for intraoral use

Handpiece must be engaged in either forward or reverse.

Practice Notes

Slow-Speed Motor attaches to tubing on dental unit.

Sterilization Notes

Slow-Speed Motor with Straight Handpiece Attachment must be lubricated and precleaned according to the manufacturer's recommendation. Then, must be either, placed in a sterilizing pouch with an internal process indicator, sealed, then sterilized OR wrapped with an internal process indicator inside and secured on the outside with process indicator tape, then sterilized. Verify appropriate color change has been achieved in external process indicator immediately after removal from sterilizer then check internal process indicator before treatment. Refer to state regulations for any additional state requirements.



Instrument

Slow-Speed Motor with Contra-Angle Handpiece Attachment

Functions

To use with burs for intraoral and extraoral procedures to remove decay, polish amalgam restorations, refine cavity preparation, adjust provisional and permanent crowns and bridges, adjust occlusal restorations, adjust partials and dentures, and to provide prophylaxis treatment

Characteristics

- Contra-angle attachment
- Slow-speed motor
- Push-button device to secure bur—Using friction grip bur
- Latch-type attachment—Using latch-type bur
Top: latch open; Bottom: latch closed

Contra-angle attaches to straight handpiece or to Slow-Speed Motor.

Types of Contra-Angle Attachments:

- Latch type—Latch-type bur, prophylaxis polishing cup or brush. Bur is secured by swivel of latch-type device in back of handpiece.
- Friction grip—Friction grip bur. Bur is secured by pushing back of handpiece.

Practice Notes

Slow-Speed Motor attaches to tubing on dental unit.

Sterilization Notes

Slow-Speed Motor with Contra-Angle Handpiece Attachment must be lubricated and precleaned according to the manufacturer's recommendation. Then, must be either, placed in a sterilizing pouch with an internal process indicator, sealed, then sterilized OR wrapped with an internal process indicator inside and secured on the outside with process indicator tape, then sterilized. Verify appropriate color change has been achieved in external process indicator immediately after removal from sterilizer then check internal process indicator before treatment. Refer to state regulations for any additional state requirements.





Instrument

Prophy Slow-Speed Handpiece/Motor* with Disposable Prophy Angle Attachment

Function

To polish teeth with prophylaxis/prophy cup or brush attachment

Characteristics

- Disposable prophy angle attachment (with rubber polishing cup)
- Prophy Slow-Speed Handpiece/Motor

Prophy angle attaches to handpiece/motor.

Ergonomic shape for natural hand positioning

Lightweight design to reduce hand and wrist fatigue

Practice Notes

Prophy Slow-Speed Handpiece/Motor attaches to tubing on dental unit.

Sterilization Notes

Prophy Slow-Speed Handpiece/Motor must be lubricated and precleaned according to the manufacturer's recommendation. Then, must be either, placed in a sterilizing pouch with an internal process indicator, sealed, then sterilized OR wrapped with an internal process indicator inside and secured on the outside with process indicator tape, then sterilized. Verify appropriate color change has been achieved in external process indicator immediately after removal from sterilizer then check internal process indicator before treatment. Refer to state regulations for any additional state requirements.





Instrument

Rechargeable Prophy Slow-Speed Handpiece/Motor- RDH Freedom™

Function

To polish teeth for prophylaxis with prophy cup and/or brush

Characteristics

- Foot Pedal-Wireless-Cordless rechargeable

To operate Foot Pedal and control speed of handpiece

RDH Freedom™ Cordless Rechargeable Prophy Handpiece.

Parts:

- Sheath—Handpiece Attachment
- Motor
- Cradle to hold the handpiece

Types of Prophy Angle Attachments:

Disposable prophy cup—For polishing all surfaces of teeth

Disposable prophy brush—For polishing occlusal surfaces and deep grooves on lingual surfaces of anterior teeth

Practice Notes

Rechargeable handpiece is used mostly on prophylaxis and sealant tray setups.

Sterilization Notes

Motor should have a barrier otherwise follow manufacture's recommendation for lubricating, precleaning, and sterilization. Sheath must be either, placed in a sterilizing pouch with an internal process indicator, sealed, then sterilized OR wrapped with an internal process indicator inside and secured on the outside with process indicator tape, then sterilized. Verify appropriate color change has been achieved in external process indicator immediately after removal from sterilizer then check internal process indicator before treatment. Disposable prophy angle attachments -rubber polishing cup or brush- must be disposed of in garbage. Single use only. Cradle should have a barrier or otherwise disinfect according to manufacturer's recommendation.

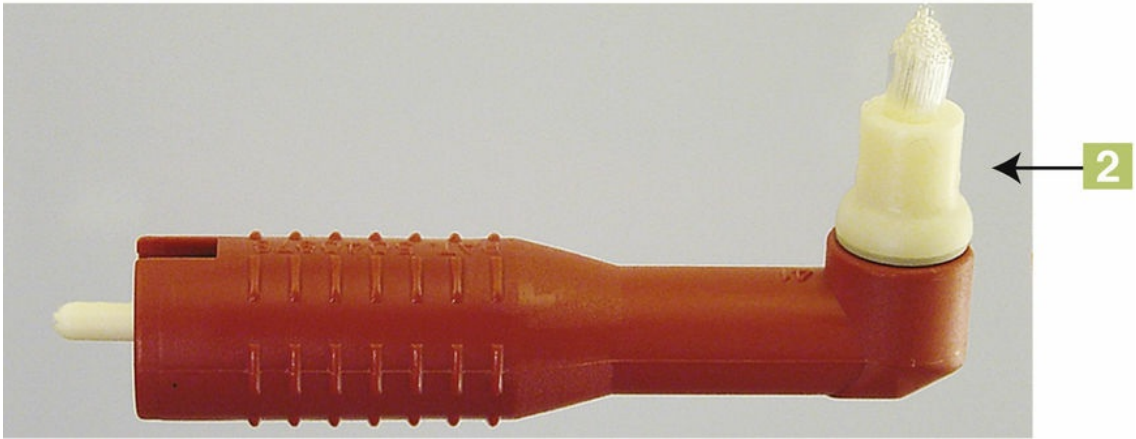
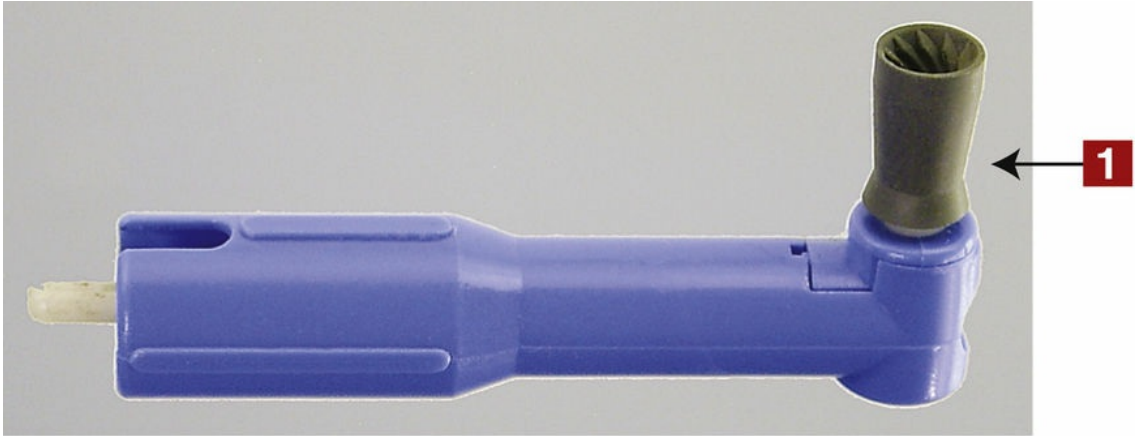

Instrument

Disposable Prophylaxis Angle Attachments for Slow-Speed Handpiece/Motor

Function

To polish teeth for prophylaxis

Characteristics

Attaches to straight or prophylaxis slow-speed handpiece/motor

Types:

- Disposable prophylaxis angle attachment with prophylaxis cup. Prophylaxis cup—Variety of flexibility and designs available for polishing all surfaces of teeth.
- Disposable prophylaxis angle attachment with tapered brush—For polishing occlusal surfaces and deep grooves on lingual surfaces of anterior teeth.

Practice Note

Disposable Prophylaxis Angle Attachments are used mostly on prophylaxis and sealant tray setups.

Sterilization Notes

Disposable Prophylaxis Angle Attachments (rubber polishing cup or brush) must be disposed of in garbage. Single use only.



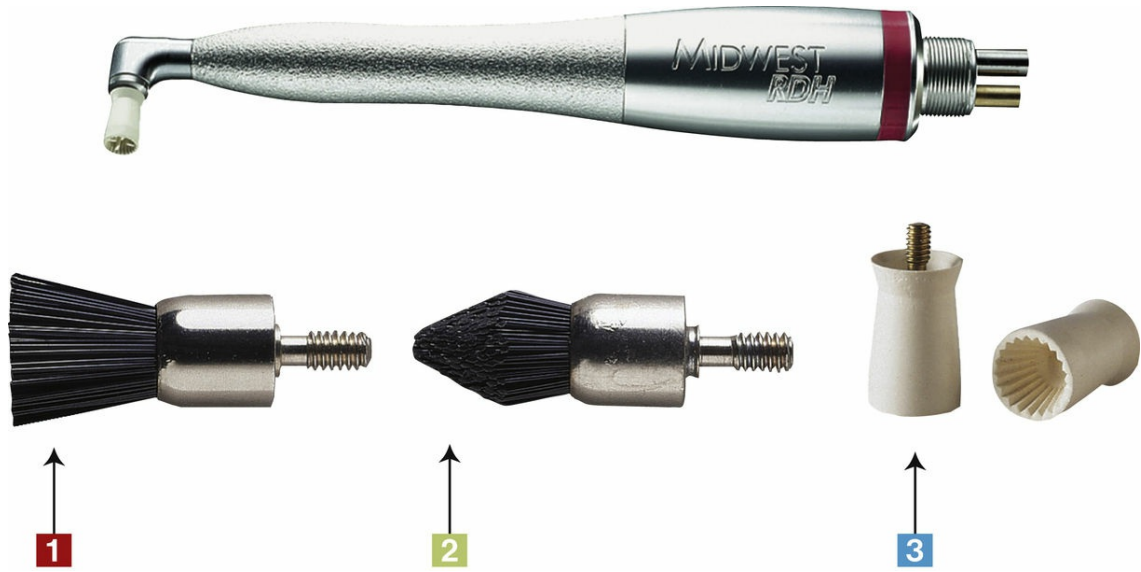

Instrument

Prophy Angle Slow-Speed Handpiece/Motor*

Function

To polish teeth for prophylaxis

Characteristics

Prophy angle slow-speed handpiece/motor is one piece.

Disposable screw-type prophy cup or brush attaches to prophy angle slow-speed handpiece/motor.

Lightweight design to reduce hand and wrist fatigue

Ergonomic shape for natural hand positioning

Attachments:

- Flat-end brush
- Tapered-end brush
- Prophy cup—Variety of flexibility and designs available

Practice Note

Prophy Angle Slow-Speed Handpiece/Motor attaches to tubing on dental unit.

Sterilization Notes

Prophy Angle Slow-Speed Handpiece/Motor must be lubricated and precleaned according to the manufacturer's recommendation. Then, must be either, placed in a sterilizing pouch with an internal process indicator, sealed, then sterilized OR wrapped with an internal process indicator inside and secured on the outside with process indicator tape, then sterilized. Verify appropriate color change has been achieved in external process indicator immediately after removal from sterilizer then check internal process indicator before treatment. Refer to state regulations for any additional state requirements. Disposable prophy polishing cup or brush must be disposed of in garbage. Single use only.



Instrument

Electric Handpiece Unit and Handpiece Attachments

Functions

To use with bur for intraoral cavity preparation

To use with endodontic nickel-titanium rotary instruments

To use with bur for trimming of provisional crowns

To use with bur for adjusting permanent restorations, crowns, and bridges

Characteristics

- Electric Handpiece Unit
- Electric Handpiece Attachments
- Electric Handpiece Motor

Speed of handpiece can be set to specific rpms.

Practice Notes

Handpiece attaches to tubing on electric handpiece unit.

Electric Handpiece is used with restorative, endodontic, and surgical tray setups.

Sterilization Notes

Electric Handpiece Motor must be lubricated and precleaned according to the manufacturer's recommendation. Then, Motor and Attachments must either, placed in a sterilizing pouch with an internal process indicator, sealed, then sterilized OR wrapped with an internal process indicator inside and secured on the outside with process indicator tape, then sterilized. Verify appropriate color change has been achieved in external process indicator immediately after removal from sterilizer then check internal process indicator before treatment. Refer to state regulations for any additional state requirements. Barriers should be used on the unit, or the manufacturer's recommendation should be followed for disinfecting the unit.



Instrument

Surgical Electrical Handpiece Unit and Handpiece Attachments

Functions

- To use with depth drills for implants
- To use with sterile water for cooling drilling system

Characteristics

Straight and contra-angled (pictured) handpiece attachments available

Maximum speed of 40,000 rpm

Lower speed (e.g., 10–50 rpm) used for implant

Fiberoptic light available for these handpieces

Practice Note

Surgical Electrical Handpiece Unit and Handpiece Attachments are used with surgical tray setups.

Sterilization Notes

Surgical Electrical Handpiece Motor must be lubricated and precleaned according to the manufacturer's recommendation. Then, Motor and Attachments must either, placed in a sterilizing pouch with an internal process indicator, sealed, then sterilized OR wrapped with an internal process indicator inside and secured on the outside with process indicator tape, then sterilized. Verify appropriate color change has been achieved in external process indicator immediately after removal from sterilizer then check internal process indicator before treatment. Barriers should be used on the unit, or the manufacturer's recommendation should be followed for disinfecting the unit. Sterile water single use only.



Instrument

Air Abrasion Unit and Handpiece Attachment

Functions

To use for class I through class VI cavity preparation
To use for preparation of occlusal surface for sealants

Characteristics

Handpiece attachment uses high pressure of alpha-alumina particles through small device that removes decay or prepares pit and fissures for sealants or restoration. Minimal use of anesthesia is required.

Practice Note

Air Abrasion Unit and Handpiece Attachment are used with class I through class VI restorative tray setups and with sealant tray setups.

Sterilization Notes

Air Abrasion Handpiece Attachments must be lubricated and precleaned according to the manufacturer's recommendation. Then, either, placed in a sterilizing pouch with an internal process indicator, sealed, then sterilized OR wrapped with an internal process indicator inside and secured on the outside with process indicator tape, then sterilized. Verify appropriate color change has been achieved in external process indicator immediately after removal from sterilizer then check internal process indicator before treatment. Refer to state regulations for any additional state requirements. Barriers should be used on the unit, or the manufacturer's recommendation should be followed for disinfecting the unit.



Instrument

Air Polisher

Function

To polish teeth by directing a high-pressure jet of pressurized air, water and mild polishing agent of sodium bicarbonate

Characteristics

- Combination of slurry of water and powder cleans or debrides the tooth surface utilizing the Air Polisher Tip
- Foot Pedal that controls the Air Polisher

Air Polisher has a self-contained water reservoir.

Air Polisher is connected to the dental unit water supply tubing.

Practice Note

Air Polisher used in place of polishing teeth with prophy paste, prophy cup, and brush.

Sterilization Notes

Air Polisher Unit Attachment tips must be precleaned, either, placed in a sterilizing pouch with an internal process indicator, sealed, then sterilized OR wrapped with an internal process indicator inside and secured on the outside with process indicator tape, then sterilized. Verify appropriate color change has been achieved in external process indicator immediately after removal from sterilizer then check internal process indicator before treatment. Refer to state regulations for any additional state requirements. Barriers should be used on the unit, and attachments or the manufacturer's recommendation should be followed for disinfecting the unit and attachments.



Instrument

Handpiece Maintenance System

Function

To flush internal air/water coolant lines on high- and slow-speed handpieces
To remove debris within handpiece and prevent buildup
To lubricate handpiece

Characteristics

- Cover encloses system
- Under cover connection for handpieces—Lift cover to access
- Start button
- Filter system

Universal adaptor for many styles of handpieces
Cleans and lubricates before bagging to sterilized
Keeps aerosols contained and filters exhaust and air from unit

Practice Note

To use, connect the instrument and close the cover and then push the start button for 2 seconds to begin automated delivery of service oil and cleaning liquid; cycle is complete in 35 seconds. Also refer to the instruction manual of the handpiece as different handpieces have to be lubricated different ways and at different times.

Sterilization Notes

Refer to the manufacturer's recommendations for cleaning and disinfecting.



Instrument

Laser Handpiece Unit and Laser Handpiece Attachment

Function

To cut, vaporize, or cauterize soft tissue

Examples

To remove lesions or tumors
To reduce excess tissue
To control bleeding

Characteristics

Works by means of a highly concentrated light source
SIROLaser (pictured) operates at a wavelength of 980 nanometers and has a power output varying from 0.5 to 7 watts.

Practice Notes

Laser Handpiece Unit and Laser Handpiece Attachment are used with specialty procedures.

Examples

Prosthodontics and Oral Surgery

Sterilization Notes

Laser Handpiece must be lubricated and precleaned according to the manufacturer's recommendation. Then, either, placed in a sterilizing pouch with an internal process indicator, sealed, then sterilized OR wrapped with an internal process indicator inside and secured on the outside with process indicator tape, then sterilized. Verify appropriate color change has been achieved in external process indicator immediately after removal from sterilizer then check internal process indicator before treatment. Refer to state regulations for any additional state requirements. Barriers should be used on the unit, or the manufacturer's recommendation should be followed for disinfecting the unit.



Instrument

Dental Unit

Functions

- To provide a delivery system for handpieces and air/water syringe
- To provide delivery system for air/water syringe
- To provide intraoral camera
- To provide a device for moving dental chair up, down, forward, and backward

Characteristics

Delivery systems provide at least two tubings—one for high-speed handpieces and one for low-speed handpiece. Above illustrates two tubing unit.
Special mechanism required for fiberoptic handpiece

Practice Notes

Different designs of dental delivery systems available in front, rear or side delivery

Air/water syringes available on one or both sides of operator or assistant's side

Barriers should be used on tubing, or the manufacturer's recommendation should be followed for disinfecting unit and tubing. All handpiece attachments and handpieces must be lubricated and precleaned according to the manufacturer's recommendation. Then, either, placed in a sterilizing pouch with an internal process indicator, sealed, then sterilized OR wrapped with an internal process indicator inside and secured on the outside with process indicator tape, then sterilized. Verify appropriate color change has been achieved in external process indicator immediately after removal from sterilizer then check internal process indicator before treatment. Refer to state regulations for any additional state requirements.

* Referred to as RDH (Registered Dental Hygiene) Prophy Angle.

* Referred to as an RDH (Registered Dental Hygienist) prophy handpiece.

Burs and Rotary Attachments for Handpieces

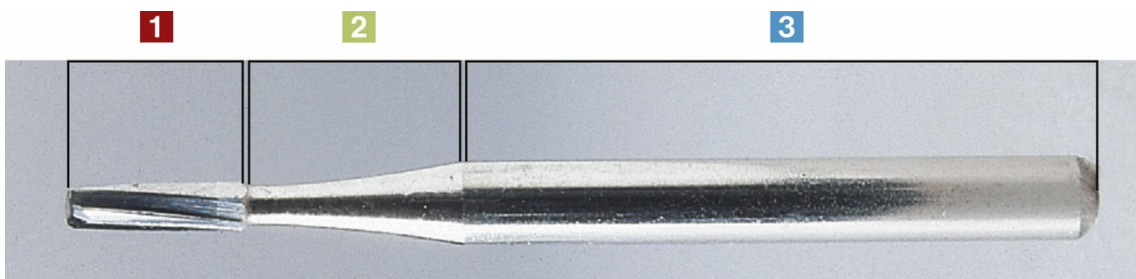
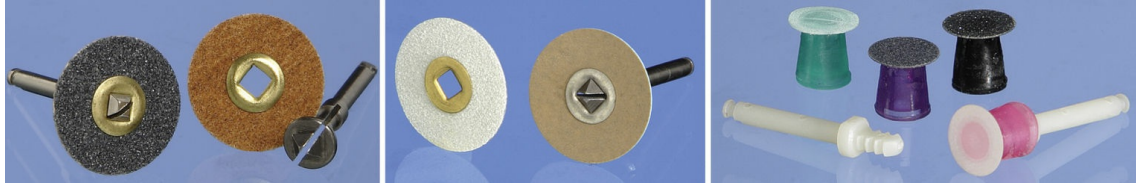

Instrument

Bur

Function

To be used in a high- or low-speed handpiece

Characteristics

Parts:

- Head: Part of bur that cuts, polishes, or finishes
 - Available in a variety of shapes and sizes
- Neck: Part of bur that tapers to connect shank to head
- Shank: Part of bur that is inserted into the handpiece
 - Length and style of shank vary depending on handpiece used.
 - Bur with straight, long shank fits into straight slow-speed handpiece.
 - Bur with latch-type shank fits into contra-angle slow-speed handpiece (friction grip bur shown).
 - Friction grip bur fits into high-speed handpiece; chuck, lever, or push button tightens bur into the handpiece.
 - Bur with long shank used for surgical procedures

Sterilization Notes

Burs must be precleaned, either, placed in a sterilizing pouch with an internal process indicator, sealed, then sterilized OR wrapped with an internal process indicator inside and secured on the outside with process indicator tape, then sterilized. Verify appropriate color change has been achieved in external process indicator immediately after removal from sterilizer then check internal process indicator before treatment. Refer to state regulations for any additional state requirements. Or, the used bur must be disposed of in a sharps container.

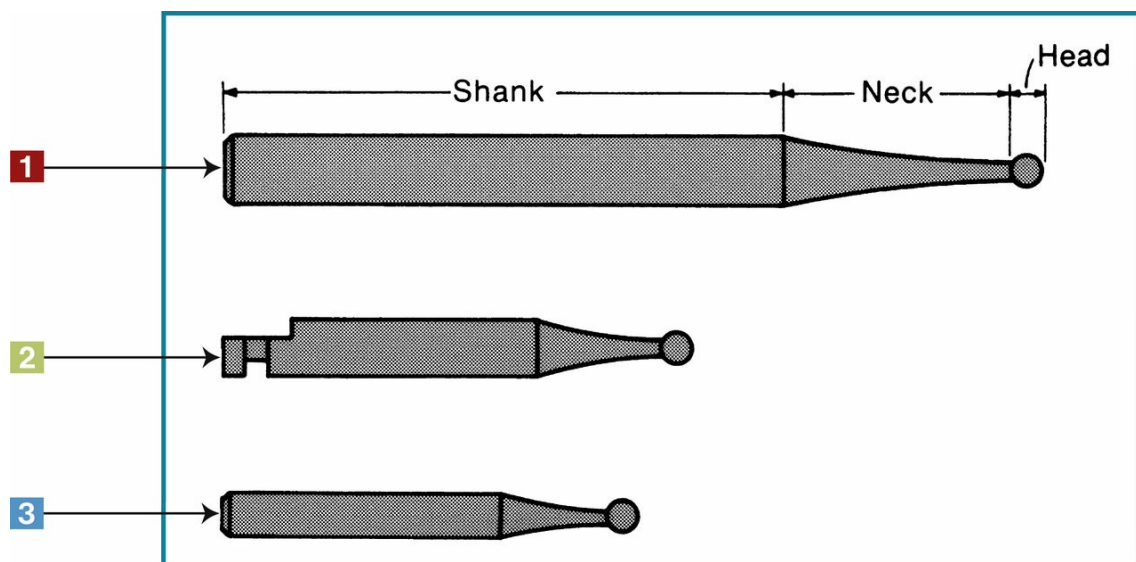

Instrument

Bur Shanks

Function

To fit shank part of bur into handpiece

Characteristics

Fit a variety of shanks into different styles of handpieces

Working or cutting end of the bur could be the same style or size, but shank could be different according to handpiece used

Examples

- No. 2 round bur in straight shank
- No. 2 round bur in latch shank
- No. 2 round bur in friction grip shank

Long shank used for surgical procedures

Sterilization Notes

Burs must be precleaned, either, placed in a sterilizing pouch with an internal process indicator, sealed, then sterilized OR wrapped with an internal process indicator inside and secured on the outside with process indicator tape, then sterilized. Verify appropriate color change has been achieved in external process indicator immediately after removal from sterilizer then check internal process indicator before treatment. Refer to state regulations for any additional state requirements. Or, the used bur must be disposed of in a sharps container.

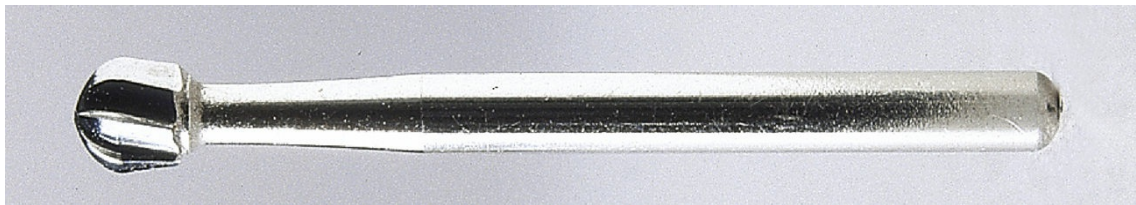

Instrument

Round Bur

Functions

- To remove caries from tooth structure
- To open tooth for endodontic treatment
- To create retention in cavity preparation
- To use for many procedures on a tooth

Characteristics

- Range of sizes
- Commonly used sizes: No. 1/4 to No. 10

Practice Notes

- Bur is inserted and secured in a handpiece.
- Type of handpiece determines type of shank used.

Sterilization Notes

A Round Bur must be precleaned, either, placed in a sterilizing pouch with an internal process indicator, sealed, then sterilized OR wrapped with an internal process indicator inside and secured on the outside with process indicator tape, then sterilized. Verify appropriate color change has been achieved in external process indicator immediately after removal from sterilizer then check internal process indicator before treatment. Refer to state regulations for any additional state requirements. Or, the used bur must be disposed of in a sharps container.

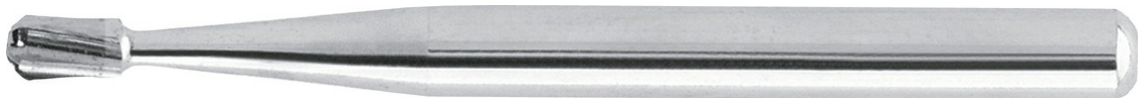
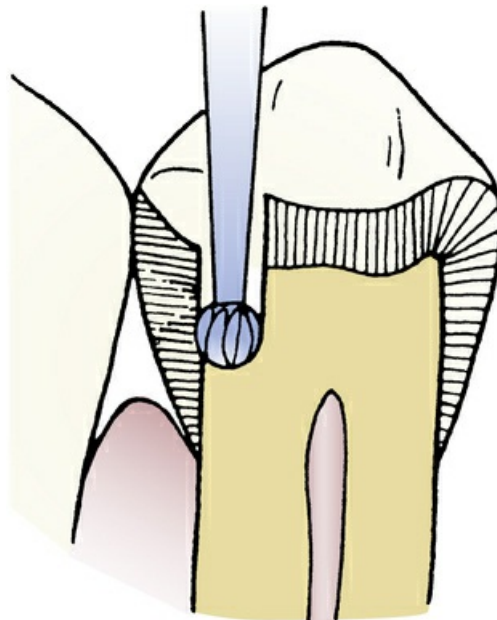

Instrument

Pear-Shaped Bur

Functions

To open tooth for a restoration
To remove caries

Characteristics

Frequently used in preparation of composite restorations
Range of sizes
Commonly used sizes: No. 330 to No. 333
Bur head available in long

Example

No. 333L

Practice Notes

Bur is inserted and secured in a handpiece.
Type of handpiece determines type of shank used.

Sterilization Notes

Pear-Shaped Bur must be precleaned, either, placed in a sterilizing pouch with an internal process indicator, sealed, then sterilized OR wrapped with an internal process indicator inside and secured on the outside with process indicator tape, then sterilized. Verify appropriate color change has been achieved in external process indicator immediately after removal from sterilizer then check internal process indicator before treatment. Refer to state regulations for any additional state requirements. Or, the used bur must be disposed of in a sharps container.

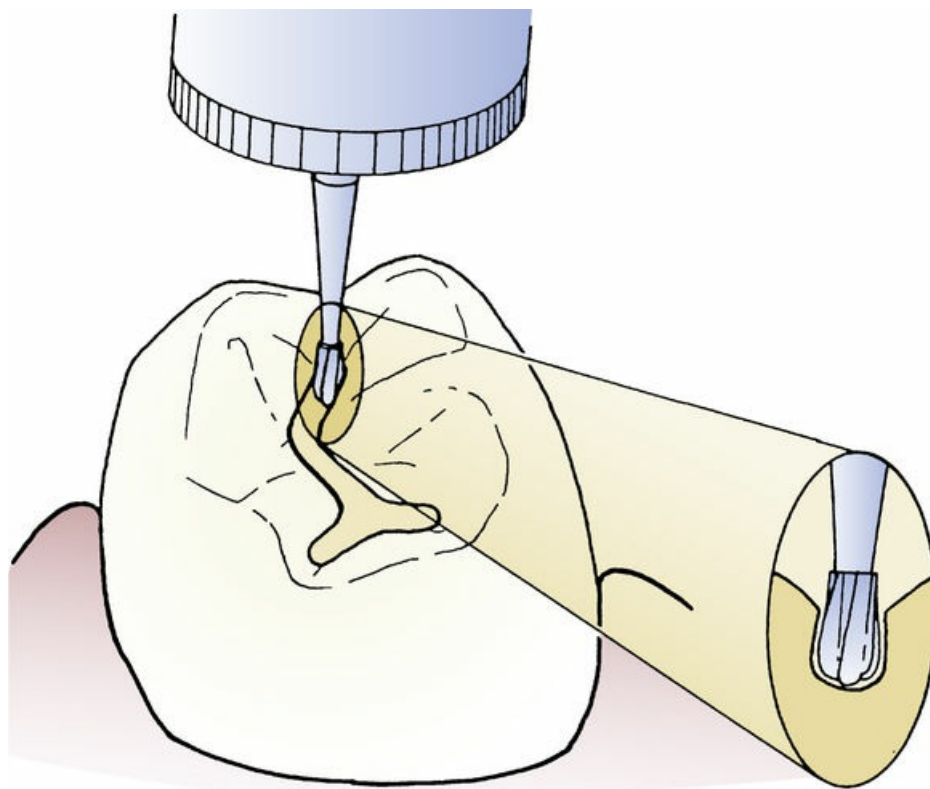

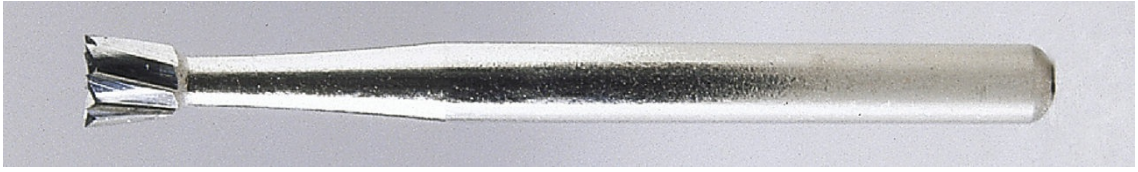

Instrument

Inverted Cone Bur

Functions

To remove caries
To establish retention in tooth for cavity preparation

Characteristics

Range of sizes
Commonly used sizes: No. 331/2, No. 34, No. 37, No. 39

Practice Notes

Bur is inserted and secured in a handpiece.
Type of handpiece determines type of shank used.

Sterilization Notes

Inverted Cone Bur must be precleaned, either, placed in a sterilizing pouch with an internal process indicator, sealed, then sterilized OR wrapped with an internal process indicator inside and secured on the outside with process indicator tape, then sterilized. Verify appropriate color change has been achieved in external process indicator immediately after removal from sterilizer then check internal process indicator before treatment. Refer to state regulations for any additional state requirements. Or, the used bur must be disposed of in a sharps container.



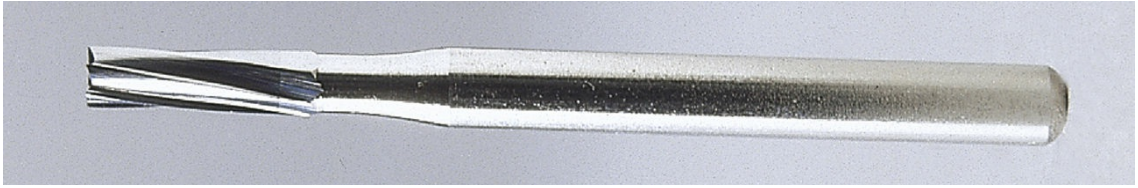

Instrument

Straight Fissure Bur—Plain Cut

Functions

- To cut cavity preparation
- To form inner walls of cavity preparation
- To create retention grooves in walls of cavity preparation

Characteristics

- Cutting part of bur—Has parallel sides
- Range of sizes—Commonly used: No. 56, No. 57, No. 58
- May have short or long (L) shank for adaptation to a variety of cavity preparations

Examples of short and long shank friction grip burs

No. 56S, No. 56L

Practice Notes

- Bur is inserted and secured in a handpiece.
- Type of handpiece determines type of shank used.

Sterilization Notes

Straight Fissure Bur—Plain Cut must be precleaned, either, placed in a sterilizing pouch with an internal process indicator, sealed, then sterilized OR wrapped with an internal process indicator inside and secured on the outside with process indicator tape, then sterilized. Verify appropriate color change has been achieved in external process indicator immediately after removal from sterilizer then check internal process indicator before treatment. Refer to state regulations for any additional state requirements. Or, the used bur must be disposed of in a sharps container.

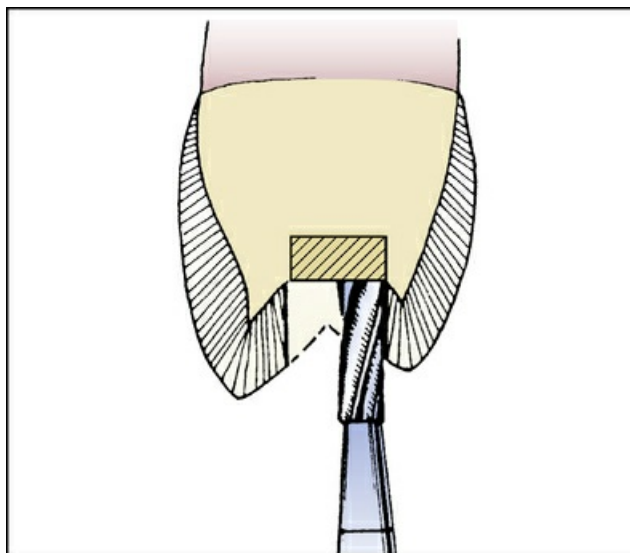

Instrument

Tapered Fissure Bur—Plain Cut

Functions

- To cut cavity preparation
- To form angles in walls of cavity preparation
- To place retention grooves in walls of cavity preparation

Characteristics

- Cutting part of bur—Has tapered sides
- Range of sizes—Commonly used: No. 168, No. 169, No. 170, No. 171
- May have short (S) or long (L) shank for adaptation to a variety of cavity preparations

Examples of short and long shank friction grip burs

No. 168S, No. 171L

Practice Notes

- Bur is inserted and secured in a handpiece.
- Type of handpiece determines type of shank used.

Sterilization Notes

Tapered Fissure Bur—Plain Cut must be precleaned, either, placed in a sterilizing pouch with an internal process indicator, sealed, then sterilized OR wrapped with an internal process indicator inside and secured on the outside with process indicator tape, then sterilized. Verify appropriate color change has been achieved in external process indicator immediately after removal from sterilizer then check internal process indicator before treatment. Refer to state regulations for any additional state requirements. Refer to state regulations for any additional state requirements. Or, used bur must be disposed of in a sharps container.

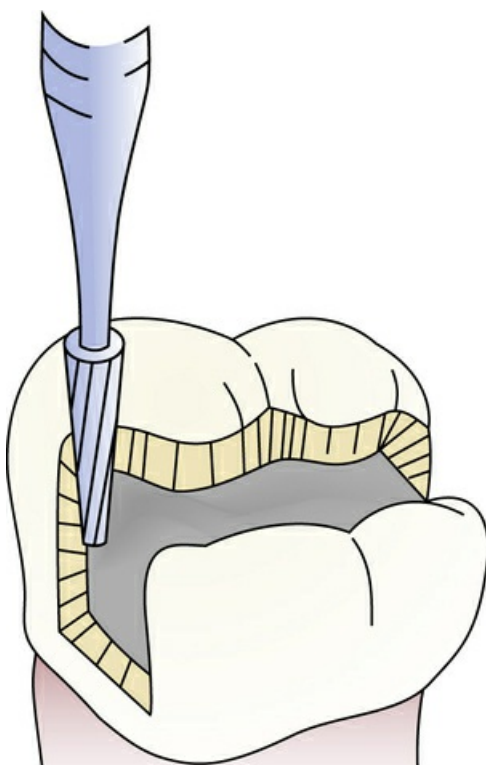



Instrument

Straight Fissure Bur—Crosscut

Functions

- To cut cavity preparation
- To form walls of cavity preparation
- To create retention grooves in walls of cavity preparation

Characteristics

- Cutting part of bur—Has parallel sides with horizontal cutting edges
- Range of sizes—Commonly used: No. 556, No. 557, No. 558
- May have long (L) shank for adaptation to a variety of cavity preparations

Example of long shank friction grip bur

No. 556L

Practice Notes

- Bur is inserted and secured in a handpiece.
- Type of handpiece determines type of shank used.

Sterilization Notes

Straight Fissure Bur—Crosscut must be precleaned, either, placed in a sterilizing pouch with an internal process indicator, sealed, then sterilized OR wrapped with an internal process indicator inside and secured on the outside with process indicator tape, then sterilized. Verify appropriate color change has been achieved in external process indicator immediately after removal from sterilizer then check internal process indicator before treatment. Refer to state regulations for any additional state requirements. Or, the used bur must be disposed of in a sharps container.

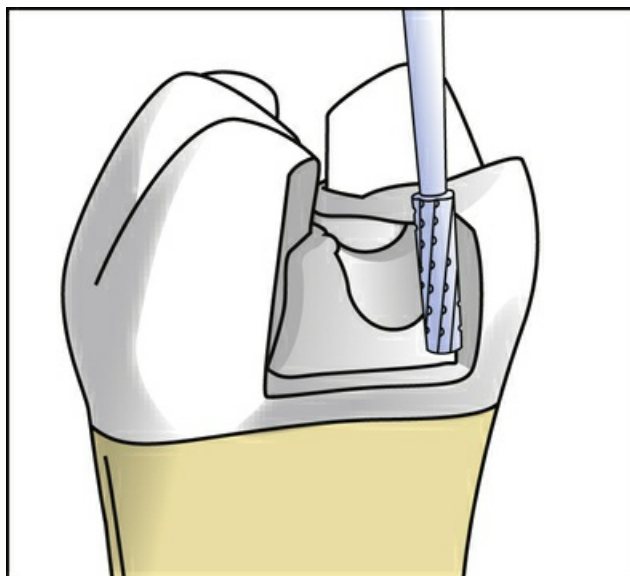

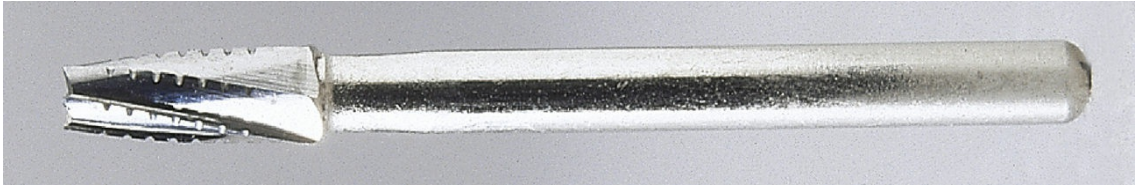

Instrument

Tapered Fissure Bur—Crosscut

Functions

- To cut cavity preparation
- To form angles in walls of cavity preparation
- To create retention grooves in walls of cavity preparation

Characteristics

- Cutting part of bur—Has tapered sides with horizontal cutting edges
- Range of sizes—Commonly used: No. 699, No. 700, No. 701, No. 702, No. 703
- May have long (L) shank for adaptation to a variety of cavity preparations

Example of long shank friction grip bur

No. 701L

Practice Notes

- Bur is inserted and secured in a handpiece.
- Type of handpiece determines type of shank used.

Sterilization Notes

Tapered Fissure Bur—Crosscut must be precleaned, either, placed in a sterilizing pouch with an internal process indicator, sealed, then sterilized OR wrapped with an internal process indicator inside and secured on the outside with process indicator tape, then sterilized. Verify appropriate color change has been achieved in external process indicator immediately after removal from sterilizer then check internal process indicator before treatment. Refer to state regulations for any additional state requirements. Or, the used bur must be disposed of in a sharps container.

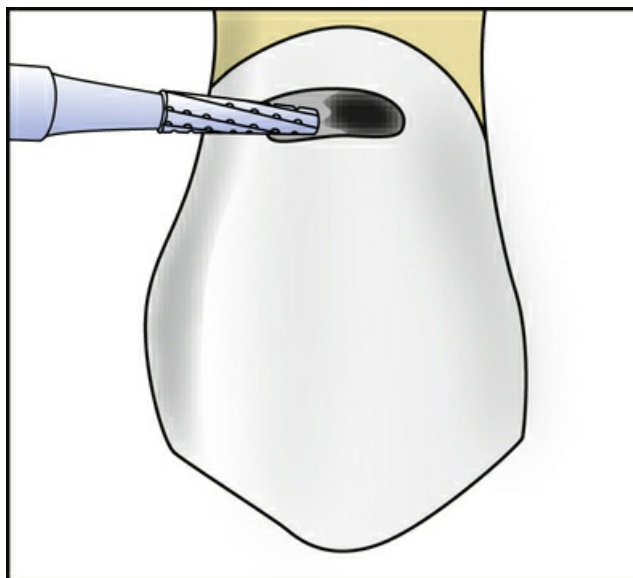

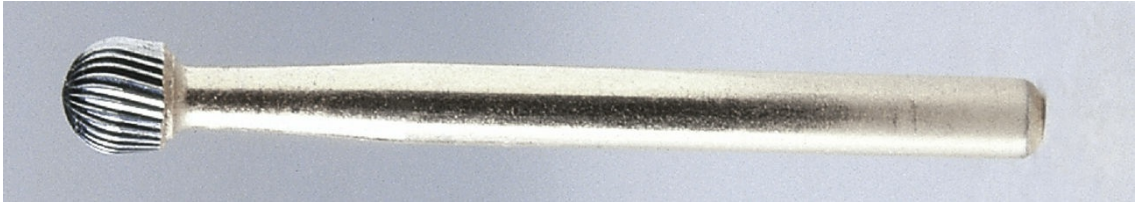

Instrument

Finishing Bur

Functions

To finish composite restoration
To finish restoration by restoring anatomy in tooth
To equilibrate or adjust occlusion

Characteristic

Variety of shapes and sizes
Finishing bur differs from the cutting burs as the working end or cutting end has an increased number of blades or flutes. An increased amount of blades will determine the greater amount of polishing capabilities.

Practice Notes

Bur is inserted and secured in a handpiece.
Type of handpiece determines type of shank used.

Sterilization Notes

Finishing Bur must be precleaned, either, placed in a sterilizing pouch with an internal process indicator, sealed, then sterilized OR wrapped with an internal process indicator inside and secured on the outside with process indicator tape, then sterilized. Verify appropriate color change has been achieved in external process indicator immediately after removal from sterilizer then check internal process indicator before treatment. Refer to state regulations for any additional state requirements. Or, the used bur must be disposed of in a sharps container.



Instrument

Diamond Bur—Flat-End Taper

Function

To reduce a tooth for crown preparation when a square shoulder is needed

Characteristics

Range of grits—Superfine to coarse; grit designated by color band on shank of diamond bur or by letter after name of diamond bur

Superfine diamond burs—Used for finishing restorations

Variety of shapes and sizes

Practice Notes

Bur is inserted and secured in a handpiece.

Type of handpiece determines type of shank used.

Sterilization Notes

Diamond Bur—Flat-End Taper must be precleaned, either, placed in a sterilizing pouch with an internal process indicator, sealed, then sterilized OR wrapped with an internal process indicator inside and secured on the outside with process indicator tape, then sterilized. Verify appropriate color change has been achieved in external process indicator immediately after removal from sterilizer then check internal process indicator before treatment. Refer to state regulations for any additional state requirements. Or, the used diamond bur must be disposed of in a sharps container.

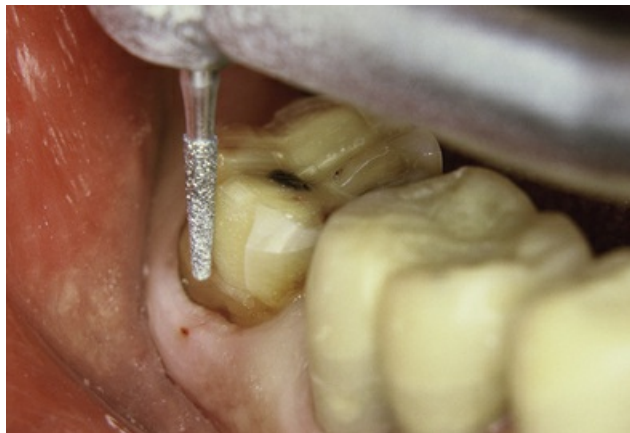

Instrument

Diamond Bur—Flat-End Cylinder

Function

To reduce a tooth for crown preparation when parallel walls and flat floors are needed

Characteristics

Range of grits—Superfine to coarse; grit designated by color band on shank of diamond bur or by letter after name of diamond bur

Superfine diamond burs—Used for finishing restorations

Variety of shapes and sizes

Practice Notes

Bur is inserted and secured in a handpiece.

Type of handpiece determines type of shank used.

Sterilization Notes

Diamond Bur—Flat-End Cylinder must be precleaned, either, placed in a sterilizing pouch with an internal process indicator, sealed, then sterilized OR wrapped with an internal process indicator inside and secured on the outside with process indicator tape, then sterilized. Verify appropriate color change has been achieved in external process indicator immediately after removal from sterilizer then check internal process indicator before treatment. Refer to state regulations for any additional state requirements. Or, the used bur must be disposed of in a sharps container.

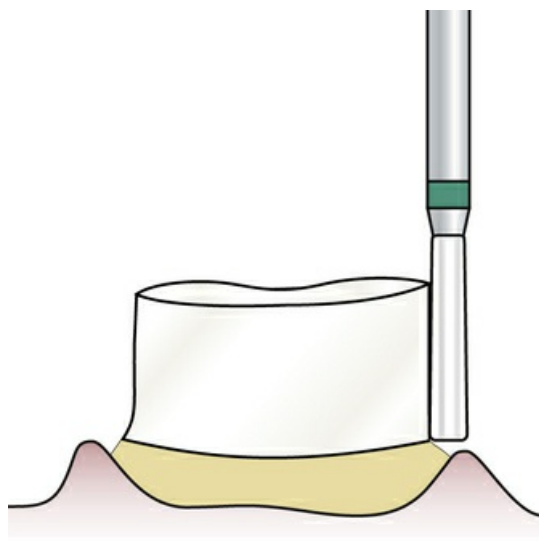

Instrument

Diamond Bur—Flame

Function

To reduce a tooth for crown preparation for subgingival margins

Characteristics

Range of grits—Superfine to coarse; grit designated by color band on shank of diamond bur or by letter after name of diamond bur

Superfine diamond burs—Used for finishing restorations

Variety of shapes and sizes

Practice Notes

Bur is inserted and secured in a handpiece.

Type of handpiece determines type of shank used.

Sterilization Notes

Diamond Bur—Flame must be precleaned, either, placed in a sterilizing pouch with an internal process indicator, sealed, then sterilized OR wrapped with an internal process indicator inside and secured on the outside with process indicator tape, then sterilized. Verify appropriate color change has been achieved in external process indicator immediately after removal from sterilizer then check internal process indicator before treatment. Refer to state regulations for any additional state requirements. Or, the used bur must be disposed of in a sharps container.

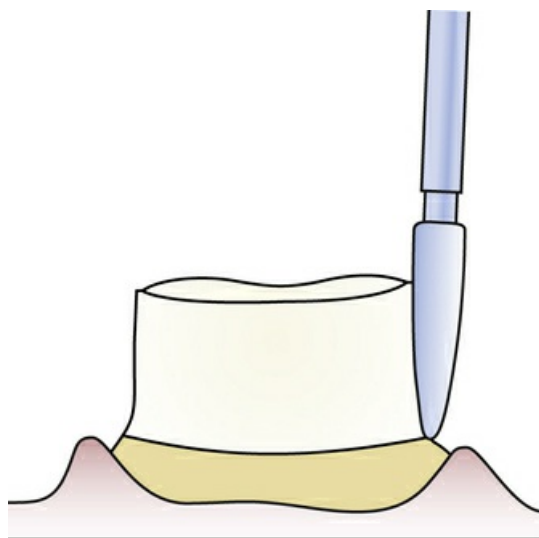

Instrument

Diamond Bur—Wheel

Function

To reduce a tooth for crown preparation on lingual aspect of anterior teeth and to reduce bulk of incisal edges

Characteristics

Range of grits—Superfine to coarse; grit designated by color band on shank of diamond bur or by letter after name of diamond bur

Superfine diamond burs—Used for finishing restorations

Variety of shapes and sizes

Practice Notes

Bur is inserted and secured in a handpiece.

Type of handpiece determines type of shank used.

Sterilization Notes

Diamond Bur—Wheel must be precleaned, either, placed in a sterilizing pouch with an internal process indicator, sealed, then sterilized OR wrapped with an internal process indicator inside and secured on the outside with process indicator tape, then sterilized. Verify appropriate color change has been achieved in external process indicator immediately after removal from sterilizer then check internal process indicator before treatment. Refer to state regulations for any additional state requirements. Or, the used bur must be disposed of in a sharps container.



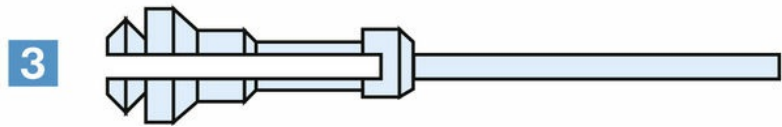
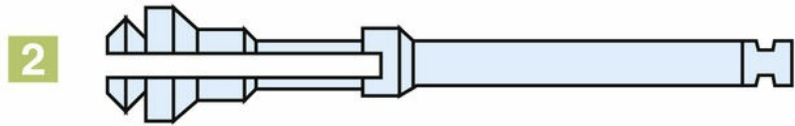
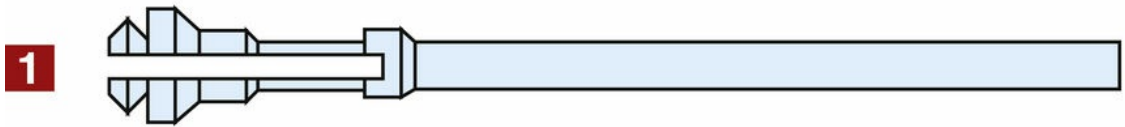
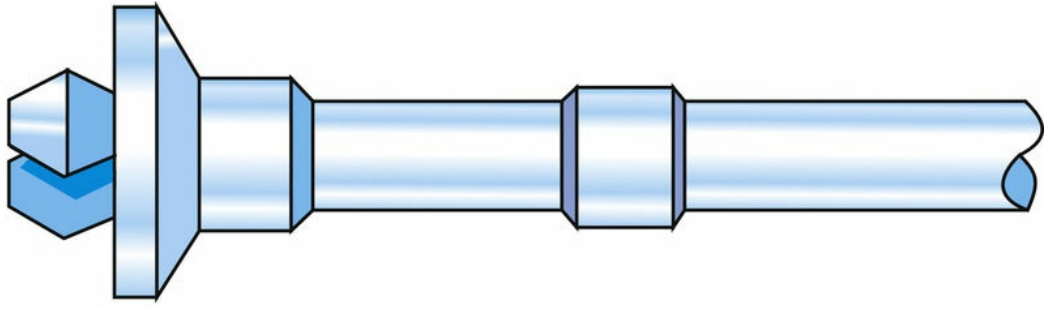

Instrument

Mandrel—Snap On

Function

To attach discs to mandrel for finishing and polishing inside or outside oral cavity (mandrel is inserted into handpiece)

Characteristics

Shank types:

- Long shank—For straight slow-speed handpiece
- Short latch-type shank—For contra-angle slow-speed handpiece
- Friction grip shank—For high-speed handpiece

Plastic disposable Snap on Mandrels available

Practice Notes

Mandrel is inserted and secured in a handpiece.
Type of handpiece determines type of shank used.

Sterilization Notes

Mandrel—Snap On must be precleaned, either, placed in a sterilizing pouch with an internal process indicator, sealed, then sterilized OR wrapped with an internal process indicator inside and secured on the outside with process indicator tape, then sterilized. Verify appropriate color change has been achieved in external process indicator immediately after removal from sterilizer then check internal process indicator before treatment. Refer to state regulations for any additional state requirements. Disposable snap-on mandrels should be disposed of in the garbage. Single use only.

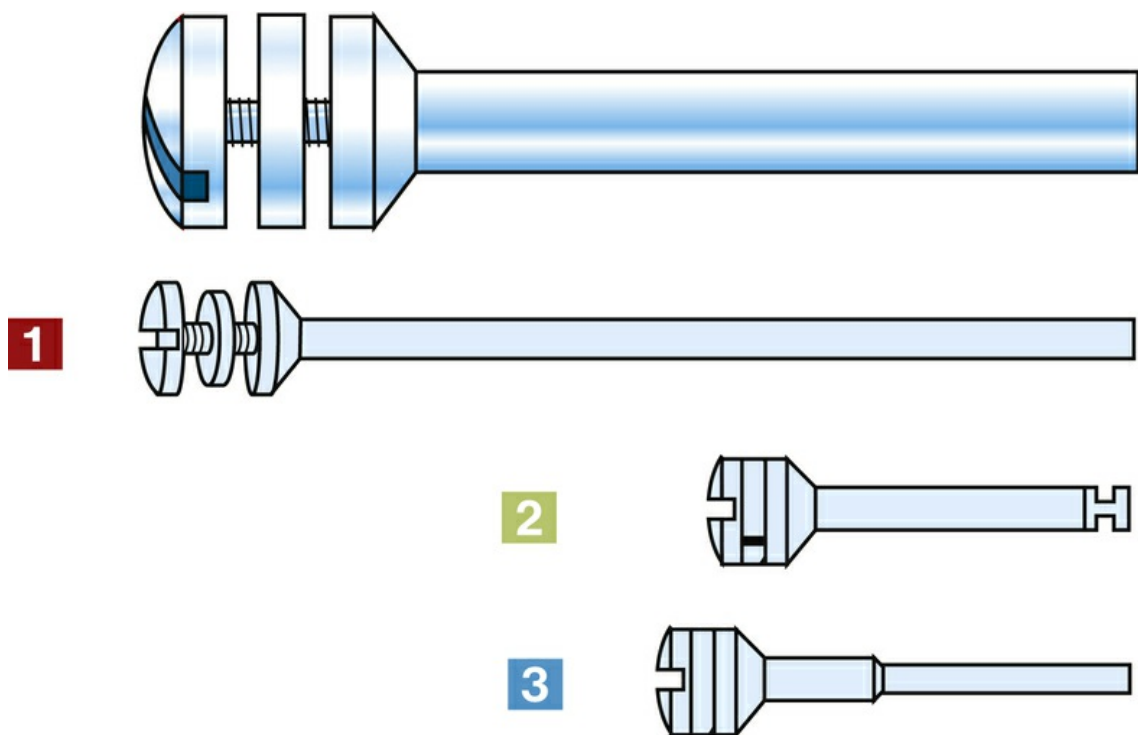

Instrument

Mandrel—Screw On

Function

To attach discs to mandrel for finishing and polishing inside or outside oral cavity (mandrel is inserted into handpiece)

Characteristics

Shank types:

- Long shank—For straight slow-speed handpiece
- Short latch-type shank—For contra-angle or right-angle slow-speed handpiece
- Friction grip shank—For high-speed handpiece

Practice Notes

Mandrel is inserted and secured in a handpiece.
Type of handpiece determines type of shank used.

Sterilization Notes

Mandrel—Screw On must be precleaned, either, placed in a sterilizing pouch with an internal process indicator, sealed, then sterilized OR wrapped with an internal process indicator inside and secured on the outside with process indicator tape, then sterilized. Verify appropriate color change has been achieved in external process indicator immediately after removal from sterilizer then check internal process indicator before treatment. Refer to state regulations for any additional state requirements.

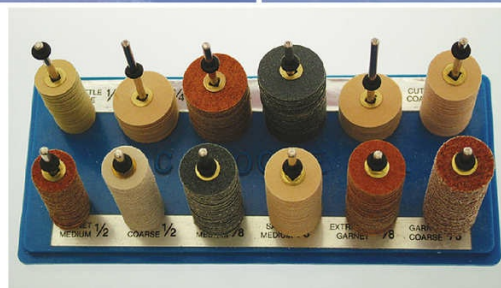

Instrument

Sandpaper Disc with Screw-Type and Snap-On Mandrel

Functions

To contour restorations
To polish restorative material (extra fine grit)

Characteristics

Range of grits (coarse to extra fine)
Darker color of disc denotes more abrasiveness

Two types:

- Screw on
- Snap on (metal center)

Sandpaper Disc organizer has a range of sizes and grits.

Practice Notes

Sandpaper Disc is attached to either a snap-on mandrel or a screw-on mandrel, depending on the type of Sandpaper Disc being used.

Sterilization Notes

Disposable Sandpaper Discs should be disposed of in the garbage. Mandrel must be precleaned, either, placed in a sterilizing pouch with an internal process indicator, sealed, then sterilized OR wrapped with an internal process indicator inside and secured on the outside with process indicator tape, then sterilized. Verify appropriate color change has been achieved in external process indicator immediately after removal from sterilizer then check internal process indicator before treatment. Refer to state regulations for any additional state requirements.



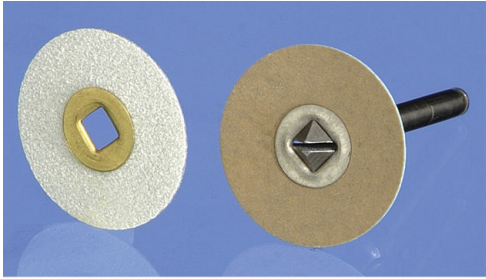

1



2

Instrument

Composite Disc

Functions

To contour restorations
To polish or smooth restorative material (extra fine grit)

Characteristics

Made from synthetic material to accommodate composite restorations
Range of grits (coarse to extra fine)
Darker color of disc denotes more abrasiveness
Variety of sizes
Two types available:

- Snap on composite disc
- Composite disc with disposable mandrel

Practice Notes

Composite Disc is attached to either a snap-on mandrel or a screw-on mandrel, depending on the type of Composite Disc being used.

Sterilization Notes

Disposable Composite Discs and disposable mandrel should be disposed of in the garbage. Single use only. Metal mandrel must be precleaned, either, placed in a sterilizing pouch with an internal process indicator, sealed, then sterilized OR wrapped with an internal process indicator inside and secured on the outside with process indicator tape, then sterilized. Verify appropriate color change has been achieved in external process indicator immediately after removal from sterilizer then check internal process indicator before treatment. Refer to state regulations for any additional state requirements.



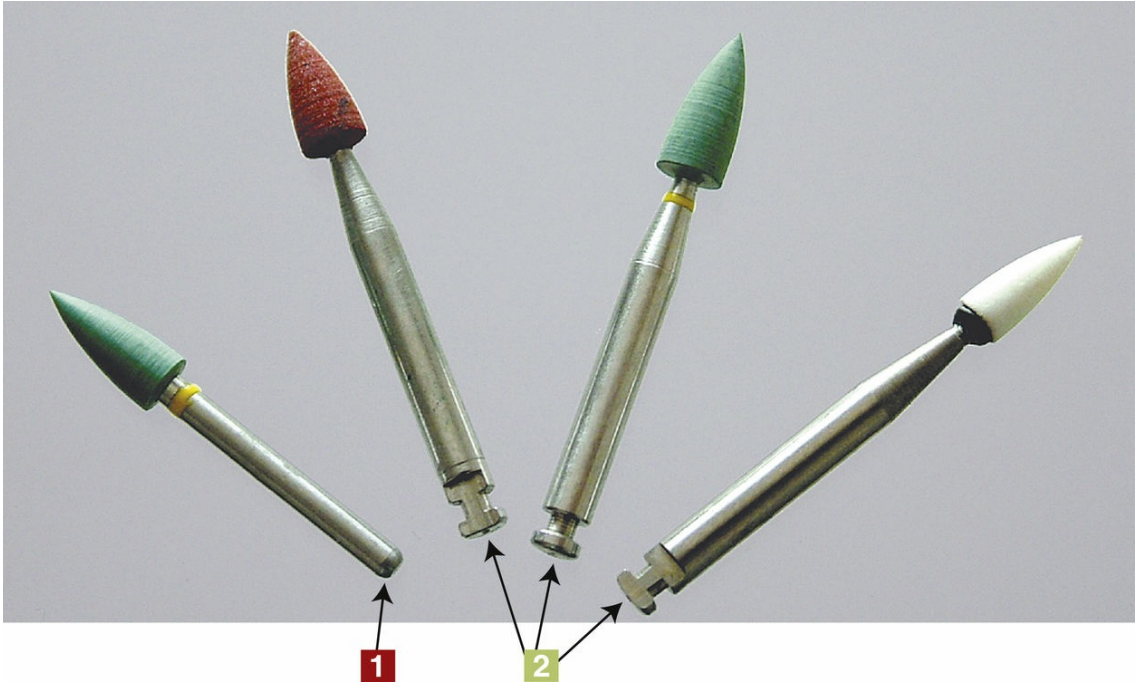

Instrument

Rubber Points

Function

To polish restorations, amalgam, composite, and gold

Characteristics

Types of polishing grits:

Brown points (brownies)—Abrasive

Green points (greenies)—Less abrasive than brownies

White points—Polishing point

Variety of shanks available for all types of rubber points:

- Friction grip
- Latch type

Practice Notes

Rubber Point is inserted and secured in a handpiece.

Type of handpiece determines type of shank used.

Sterilization Notes

Rubber Point must be precleaned, either, placed in a sterilizing pouch with an internal process indicator, sealed, then sterilized OR wrapped with an internal process indicator inside and secured on the outside with process indicator tape, then sterilized. Verify appropriate color change has been achieved in external process indicator immediately after removal from sterilizer then check internal process indicator before treatment. Refer to state regulations for any additional state requirements.



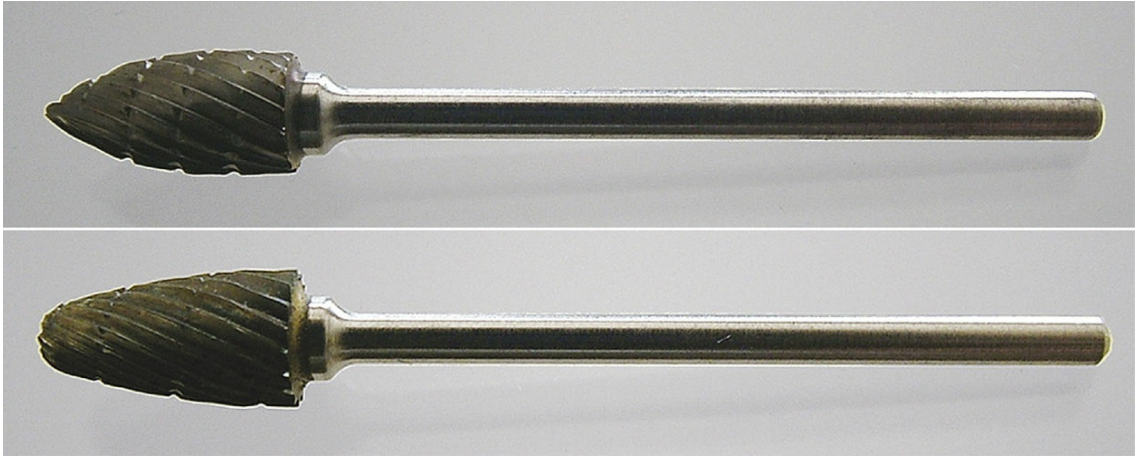

Instrument

Laboratory Bur—Acrylic Bur

Function

To cut models or trim acrylic in laboratory

Characteristics

Long shank—For attachment to straight handpiece
Variety of sizes and shapes

Practice Notes

Laboratory Bur is inserted and secured in a slow-speed handpiece with a straight attachment.

Sterilization Notes

Laboratory Bur—Acrylic Bur, when used on any patient's appliances must be precleaned, either, placed in a sterilizing pouch with an internal process indicator, sealed, then sterilized OR wrapped with an internal process indicator inside and secured on the outside with process indicator tape, then sterilized. Verify appropriate color change has been achieved in external process indicator immediately after removal from sterilizer then check internal process indicator before use. Refer to state regulations for any additional state requirements.





Instrument

Laboratory Bur—Diamond Disc

Function

To contour or cut models in the laboratory

Characteristic

Single- or double-sided cutting edge

Practice Note

Laboratory Bur—Diamond Disc is inserted and secured in a slow-speed handpiece with a straight attachment.

Sterilization Notes

Laboratory Bur—Diamond Disc, when used on any patient's appliances must be precleaned, either, placed in a sterilizing pouch with an internal process indicator, sealed, then sterilized OR wrapped with an internal process indicator inside and secured on the outside with process indicator tape, then sterilized. Verify appropriate color change has been achieved in external process indicator immediately after removal from sterilizer then check internal process indicator before use. Refer to state regulations for any additional state requirements.



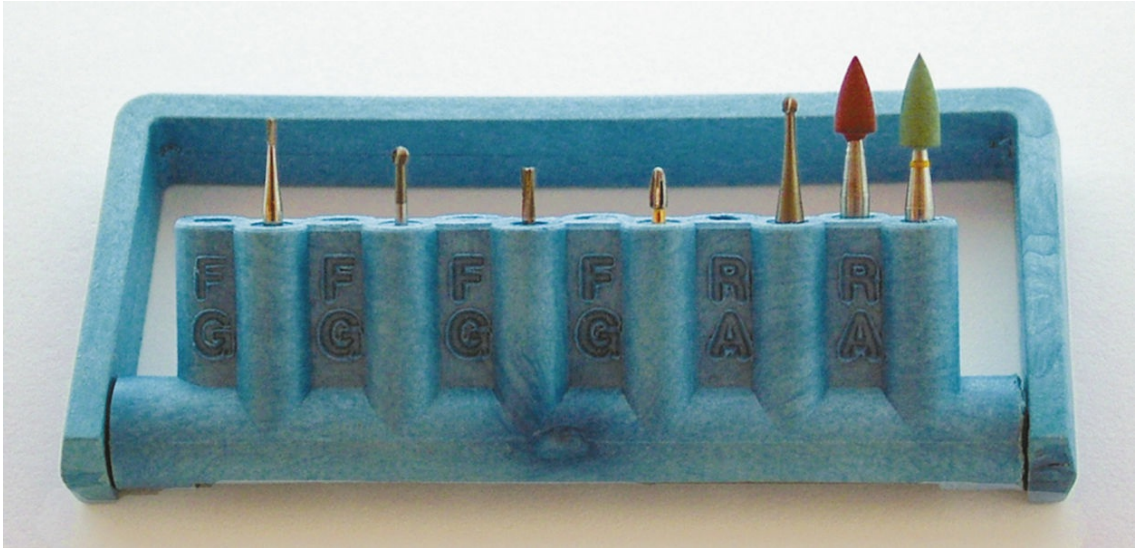

Instrument

Magnetic Bur Block with Burs

Function

To be used on dental tray setups

Characteristics

Magnetic to hold burs in place
Holds friction grip and latch-type burs
Variety of shapes and sizes available
Various colors available to coordinate with color of tray

Practice Note

Magnetic Bur Blocks with Burs are used on most restorative tray setups.

Sterilization Notes

Magnetic Bur Block with Burs must be precleaned, either, placed in a sterilizing pouch with an internal process indicator, sealed, then sterilized OR wrapped with an internal process indicator inside and secured on the outside with process indicator tape, then sterilized. Verify appropriate color change has been achieved in external process indicator immediately after removal from sterilizer then check internal process indicator before treatment. Refer to state regulations for any additional state requirements.

Dental Dam Instruments



Instrument

Dental Dam

Function

To isolate teeth for dental procedures

Characteristics

Sizes— 4×4 , 5×5 , 6×6 , or continuous roll

Gauge or thickness—Thin, medium, heavy

Colors—Gray, green, blue, pastels

Latex free—Purple

Practice Notes

Latex-free Dental Dam (purple) is used for patients who have latex allergy.

Sterilization Notes

Dental Dam should be disposed of in garbage. Single use only.





Instrument

Dental Dam Stamp

Function

To mark holes on dental dam

Characteristics

Has 32 dots that represent the adult dentition
Used as guide for punching holes in correct position

Practice Notes

The oral cavity is examined before holes are marked and punched to adjust positioning to the patient's specific dentition.

Sterilization Notes

Dental Dam Stamp should be disinfected according to the manufacturer's recommendation.

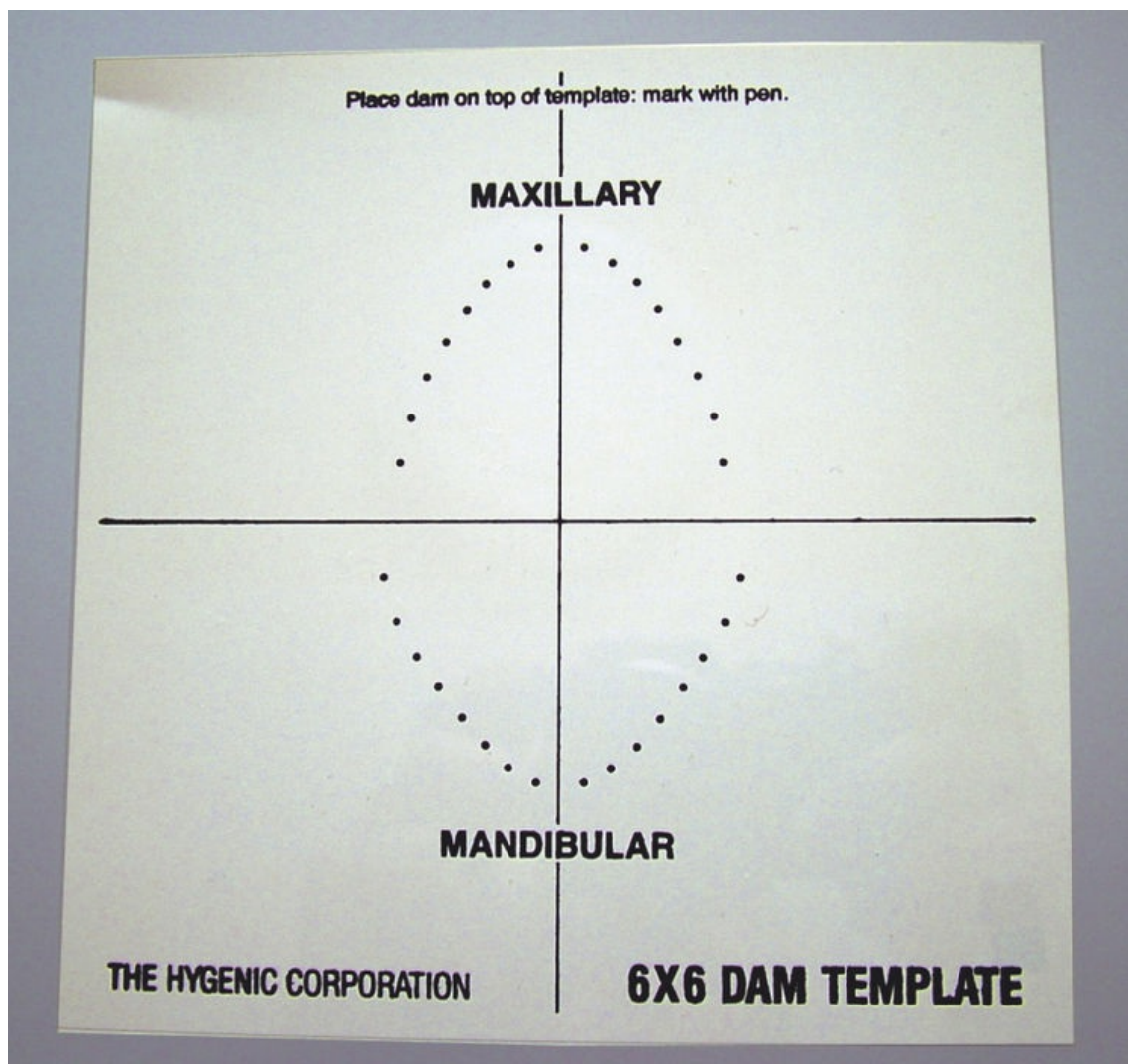

Instrument

Dental Dam Template

Function

To use as a guide for marking and punching holes in correct position on dental dam

Characteristics

Made of durable plastic

Has 32 dots that represent the adult dentition

Practice Notes

The oral cavity is examined before holes are marked and punched to adjust positioning to the patient's specific dentition.

The dental dam is placed on the template, and the points where holes should be punched are marked with a pen.

Sterilization Notes

Dental Dam Template should be disinfected according to the manufacturer's recommendation.



Instrument

Dental Dam Punch

Function

To punch holes in dental dam for each individual tooth

Characteristics

Designated hole size for each tooth for permanent dentition:

No. 5—Anchor tooth (largest)

No. 4—Molars

No. 3—Premolars

No. 2—Maxillary central and laterals, maxillary and mandibular cuspids

No. 1—Mandibular central and laterals (smallest)

Practice Notes

The oral cavity is examined before holes are punched to accommodate the patient's specific dentition.

A space of 3 to 3.5 mm is maintained between holes.

Sterilization Notes

Dental Dam Punch must be precleaned open and unlocked, placed in an open and unlocked position either in a sterilizing pouch with an internal process indicator, sealed, then sterilized OR wrapped with an internal process indicator inside and secured on the outside with process indicator tape, then sterilized. Verify appropriate color change has been achieved in external process indicator immediately after removal from sterilizer then check internal process indicator before treatment. Refer to state regulations for any additional state requirements.

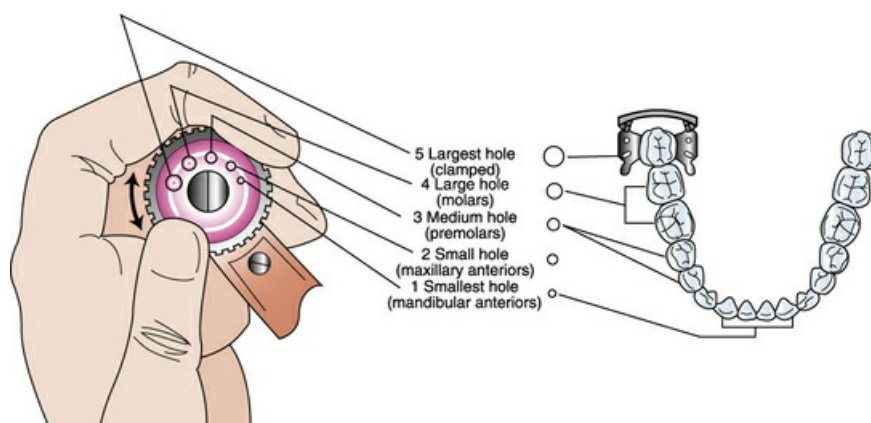

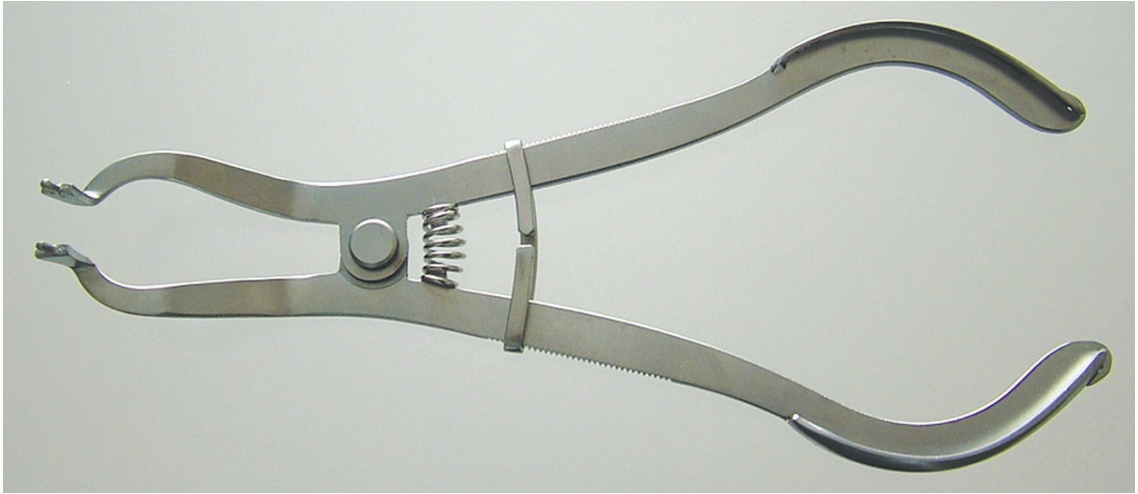

Instrument

Dental Dam Forceps

Function

To place dental dam clamp on tooth and to remove clamp after procedure

Characteristics

Beaks on forceps fit into dental dam clamp.

Forceps open with spring motion.

Bar between handle holds forceps in place while clamp is seated.

Practice Note

Squeeze handles on dental dam forceps to open working end.

Sterilization Notes

Dental Dam Forceps must be precleaned open and unlocked, placed in an open and unlocked position either in a sterilizing pouch with an internal process indicator, sealed, then sterilized OR wrapped with an internal process indicator inside and secured on the outside with process indicator tape, then sterilized. Verify appropriate color change has been achieved in external process indicator immediately after removal from sterilizer then check internal process indicator before treatment. Refer to state regulations for any additional state requirements. For safety, dental floss (ligature tie) must be attached to each dental clamp before each use to allow for retrieval of clamp if dislodged and patient inhales or swallows.

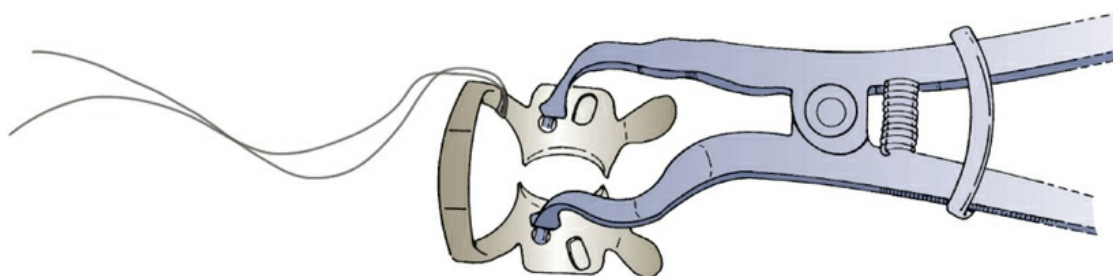

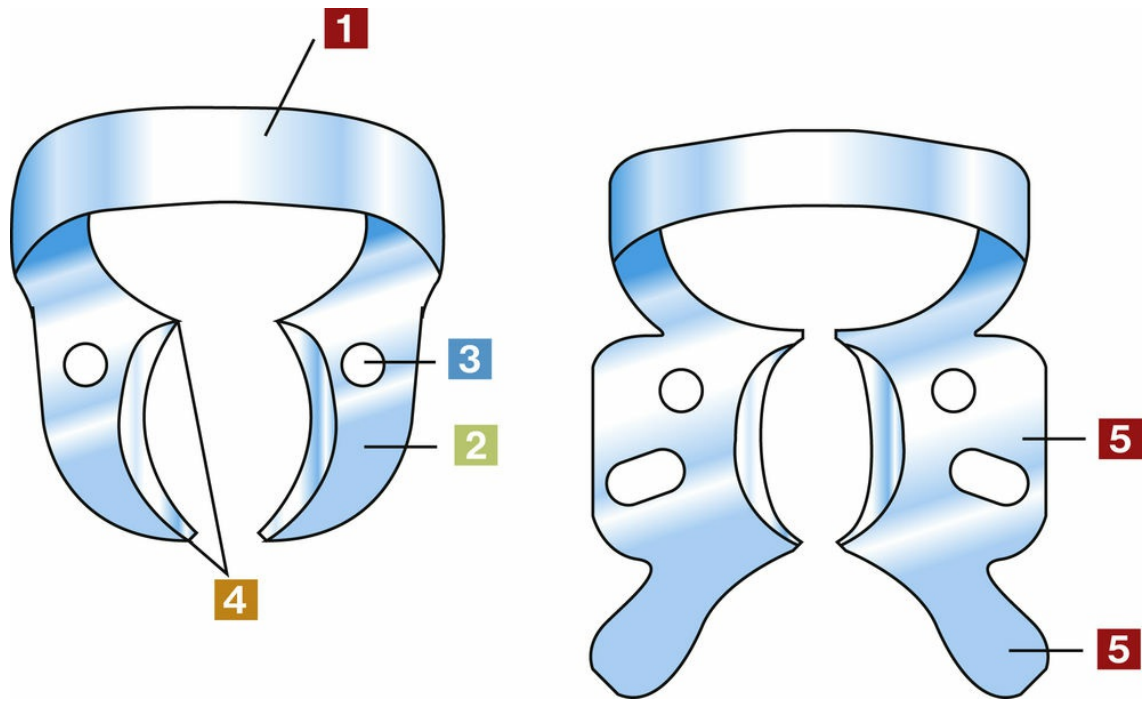

Instrument

Dental Dam Clamp

Function

To anchor and stabilize dental dam

Characteristics

Parts:

- Bow: Placed toward distal part of tooth
- Jaws: Have four prongs that secure clamp on tooth
- Holes: On jaws; designated for beaks on forceps to place clamp on tooth
- Prongs: Designed to secure clamp on cervical part of tooth, beyond the height of contour
- Winged clamps: Have extension of metal on jaws to hold dental dam away for better visibility
(Wingless clamps do not have extra extension of metal.)

For safety, dental floss (ligature tie) must be attached to each dental clamp before each use to allow for retrieval of clamp if dislodged and patient inhales or swallows.

Sterilization Notes

Dental Dam Clamp must be precleaned, either, placed in a sterilizing pouch with an internal process indicator, sealed, then sterilized OR wrapped with an internal process indicator inside and secured on the outside with process indicator tape, then sterilized. Verify appropriate color change has been achieved in external process indicator immediately after removal from sterilizer then check internal process indicator before treatment. Refer to state regulations for any additional state requirements.



Instrument

Anterior Clamp

Function

To anchor and stabilize dental dam

Characteristics

Used only on anterior teeth

Example

Wingless clamp

Range of sizes available

Practice Notes

Anterior clamp is used on a dental dam setup for restorative and endodontic procedures. For safety, dental floss (ligature tie) must be attached to each dental clamp before each use to allow for retrieval of clamp if dislodged and patient inhales or swallows.

Sterilization Notes

Anterior Clamp must be precleaned, either, placed in a sterilizing pouch with an internal process indicator, sealed, then sterilized OR wrapped with an internal process indicator inside and secured on the outside with process indicator tape, then sterilized. Verify appropriate color change has been achieved in external process indicator immediately after removal from sterilizer then check internal process indicator before treatment. Refer to state regulations for any additional state requirements.



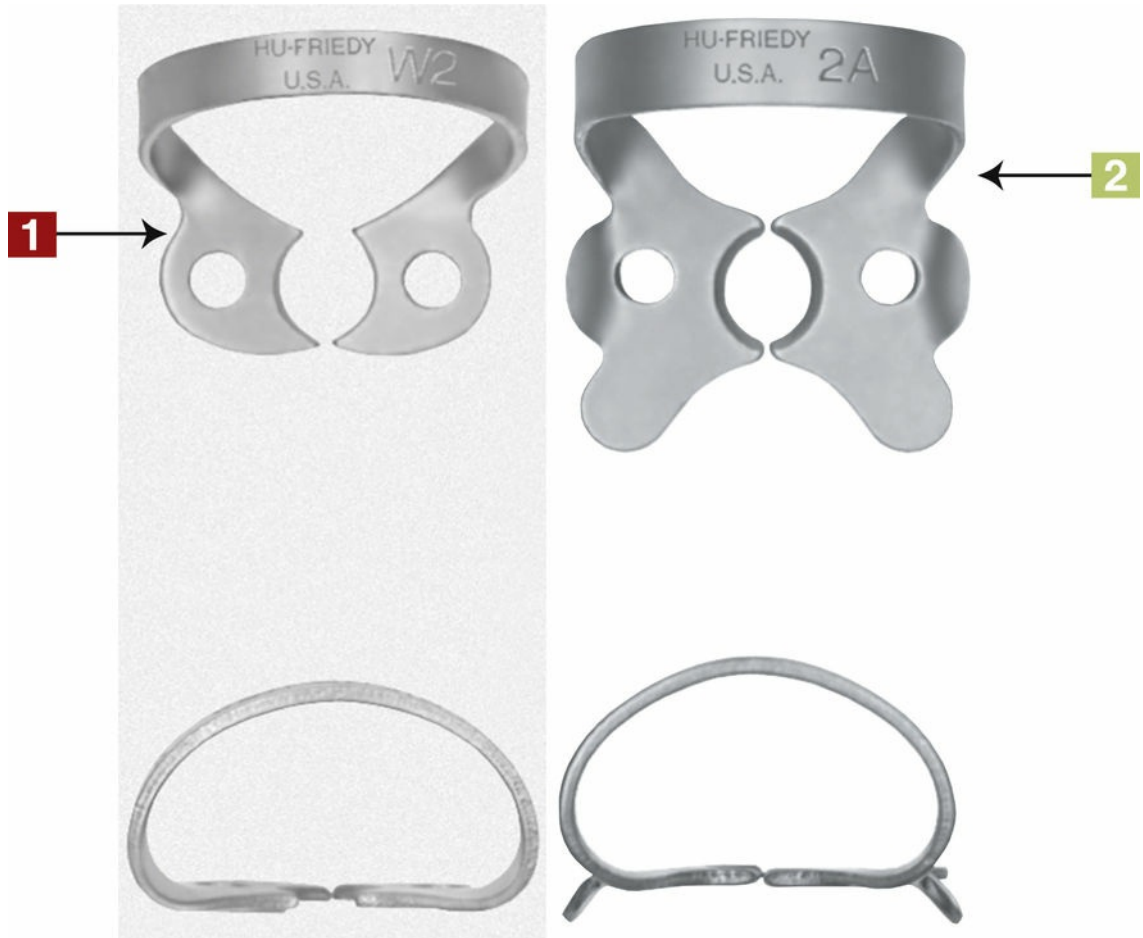

Instrument

Premolar Clamp

Function

To anchor and stabilize dental dam

Characteristics

Clamp used is determined by tooth size.

Range of sizes available

Variety of styles

Examples

- Wingless clamp
- Winged clamp

Practice Notes

Premolar Clamp is used on a dental dam setup for restorative and endodontic procedures.

For safety, dental floss (ligature tie) must be attached to each dental clamp before each use to allow for retrieval of clamp if dislodged and patient inhales or swallows.

Sterilization Notes

Premolar Clamp must be precleaned, either, placed in a sterilizing pouch with an internal process indicator, sealed, then sterilized OR wrapped with an internal process indicator inside and secured on the outside with process indicator tape, then sterilized. Verify appropriate color change has been achieved in external process indicator immediately after removal from sterilizer then check internal process indicator before treatment. Refer to state regulations for any additional state requirements.

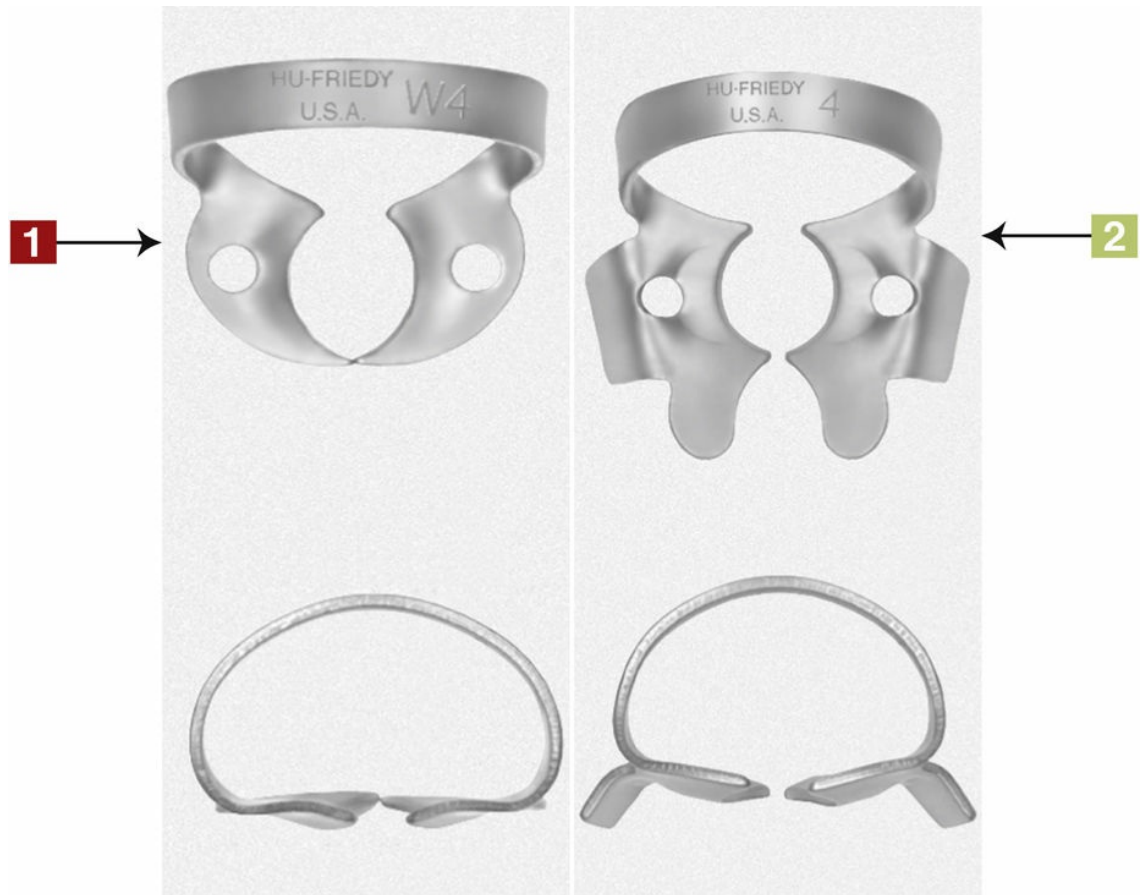

Instrument

Universal Clamp—Maxillary

Function

To anchor and stabilize dental dam

Characteristics

Used on right or left posterior molars

Range of sizes available

Variety of styles

Examples

- Wingless clamp
- Winged clamp

Practice Notes

Maxillary Clamp is used on a dental dam setup for restorative and endodontic procedures. For safety, dental floss (ligature tie) must be attached to each dental clamp before each use to allow for retrieval of clamp if dislodged and patient inhales or swallows.

Sterilization Notes

Universal Maxillary Clamp must be precleaned, either, placed in a sterilizing pouch with an internal process indicator, sealed, then sterilized OR wrapped with an internal process indicator inside and secured on the outside with process indicator tape, then sterilized. Verify appropriate color change has been achieved in external process indicator immediately after removal from sterilizer then check internal process indicator before treatment. Refer to state regulations for any additional state requirements.



Instrument

Universal Clamp—Mandibular

Function

To anchor and stabilize dental dam

Characteristics

Used on right or left posterior molars

Range of sizes available

Variety of styles

Examples

- Wingless clamp
- Winged clamp

Practice Notes

Mandibular Clamp is used on a dental dam setup for restorative and endodontic procedures. For safety, dental floss (ligature tie) must be attached to each dental clamp before each use to allow for retrieval of clamp if dislodged and patient inhales or swallows.

Sterilization Notes

Universal Mandibular Clamp must be precleaned, either, placed in a sterilizing pouch with an internal process indicator, sealed, then sterilized OR wrapped with an internal process indicator inside and secured on the outside with process indicator tape, then sterilized. Verify appropriate color change has been achieved in external process indicator immediately after removal from sterilizer then check internal process indicator before treatment. Refer to state regulations for any additional state requirements.

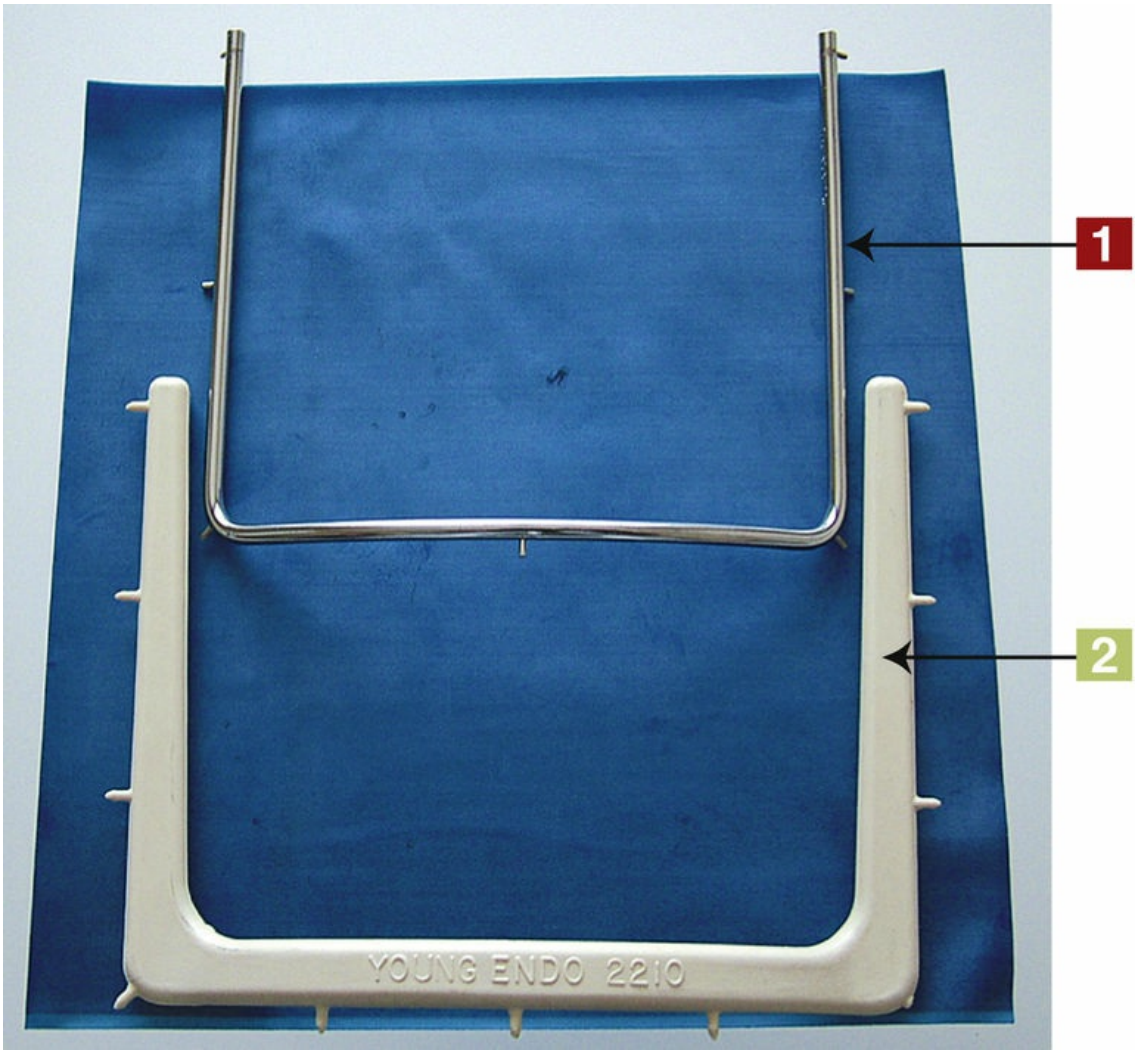

Instrument

Dental Dam Frame

Function

To hold dental dam away from teeth

Characteristics

- Metal frame
- Plastic frame

Plastic frame—May be left on during radiographic exposures

Various styles of frames available

Practice Notes

Dental Dam Frame is used on a dental dam setup for restorative and endodontic procedures.

Sterilization Notes

Dental Dam Frame must be precleaned, either, placed in a sterilizing pouch with an internal process indicator, sealed, then sterilized OR wrapped with an internal process indicator inside and secured on the outside with process indicator tape, then sterilized. Verify appropriate color change has been achieved in external process indicator immediately after removal from sterilizer then check internal process indicator before treatment. Refer to state regulations for any additional state requirements.



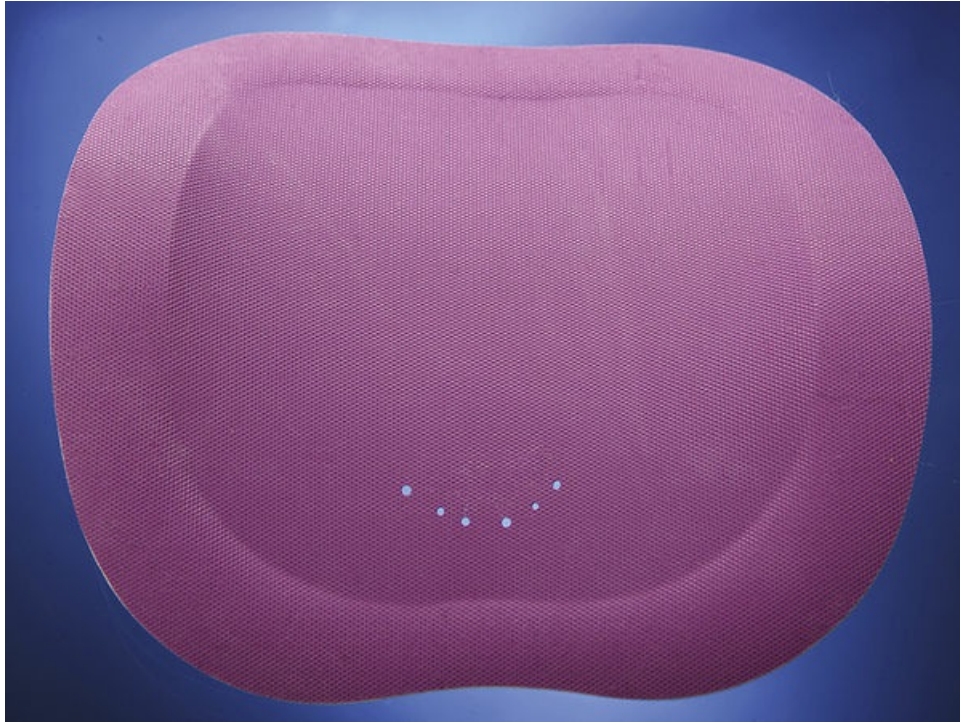

Instrument

Preframed Dental Dam

Function

To isolate teeth for dental procedures

Characteristics

Frame is attached to dental dam

Dental dams may come pre-punched – additional holes can be punched

Practice Note

Dental Dam is latex free.

Dam adjusts to the side for easy access for radiograph

Dam shown with secure ligatures to hold Dental Dam in place instead of Dental Dam clamp.

Sterilization Notes

Dental Dam should be disposed of in garbage. Single use only.

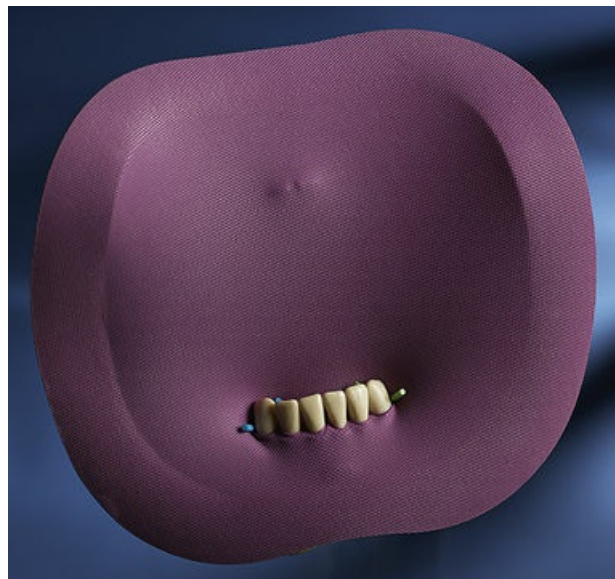



Tray Setup

Dental Dam

Left (Top to Bottom)

Dental dam (latex free), dental floss, plastic dental dam frame, crown and bridge scissors (see [Chapter 10](#))

Right (Top to Bottom)

Beavertail burnisher used to invert Dental Dam (see [Chapter 8](#)), dental dam forceps, dental dam clamp with stabilizing ligature tie (dental floss), Dental Dam punch

Sterilization Notes

Refer to each individual instrument for correct procedure for sterilization or disposal of instrument or material.

Amalgam Restorative Instruments

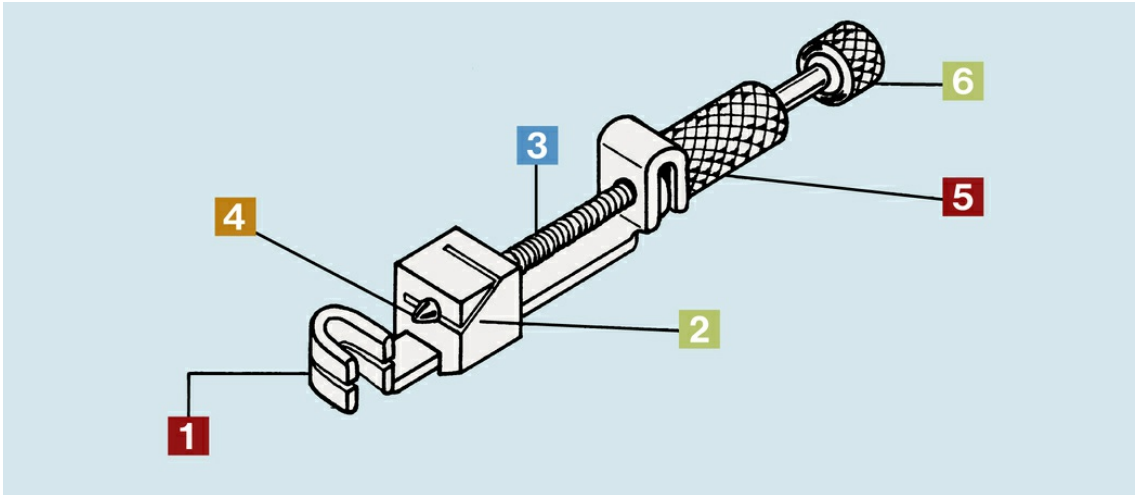

Instrument

Tofflemire/Matrix Band Retainer

Function

To hold and maintain stability of matrix band during condensation of restorative material for class II preparation

Characteristics

Parts:

- Guide slots: Straight slot; right and left slots for right or left quadrant
- Diagonal slot: Slides up and down on spindle; matrix band is placed in slot, and spindle secures band in place; open slots are placed toward gingiva.
- Spindle: Holds matrix band in retainer
- Spindle pin: Stabilizes band in holder
- Inner knob: Adjusts size of the loop of matrix band to fit around tooth and loosens band for removal
- Outer knob: Positioned at end of spindle that tightens or loosens matrix band in retainer

Practice Notes

Tofflemire Band Retainer is used on restorative tray setups.

The photo shown is for maxillary right quadrant and mandibular left quadrant.

Sterilization Notes

Tofflemire Band Retainer must be precleaned open and unlocked, spindle should be disengaged, then, placed in an open and unlocked position either in a sterilizing pouch with an internal process indicator, sealed, then sterilized OR wrapped with an internal process indicator inside and secured on the outside with process indicator tape, then sterilized. Verify appropriate color change has been achieved in external process indicator immediately after removal from sterilizer then check internal process indicator before treatment. Refer to state regulations for any additional state requirements.



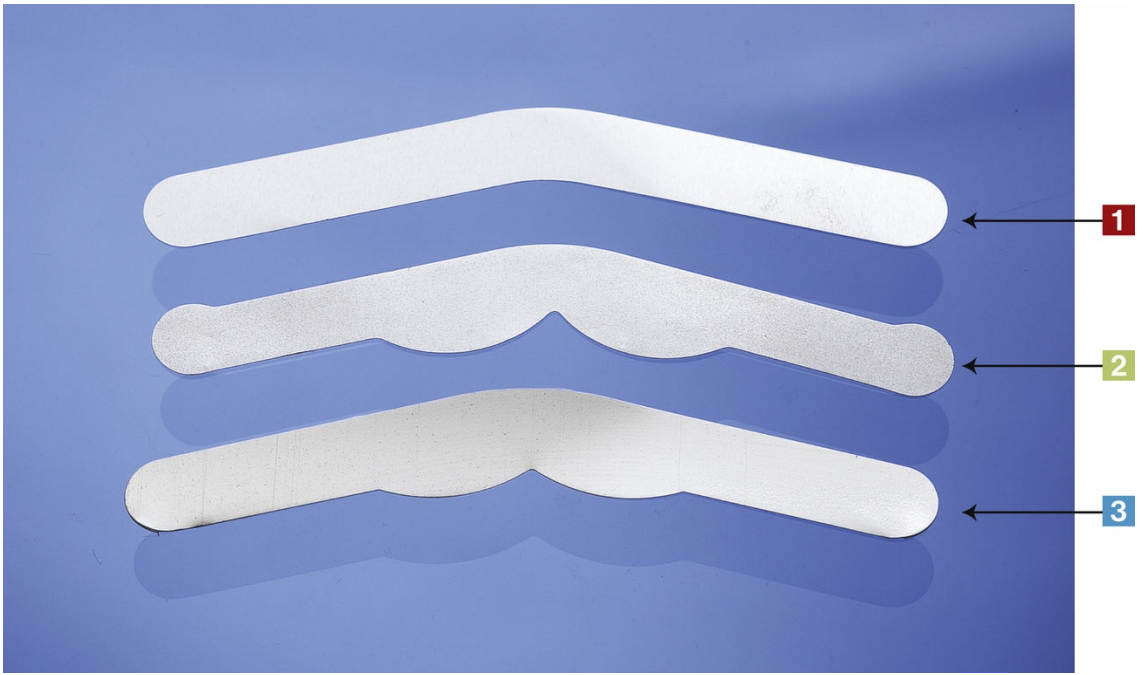

Instrument

Matrix Bands

Function

To replace missing proximal wall or walls of cavity preparation for condensation of restorative material for class II preparations

Characteristics

Variety of sizes, shapes, and thicknesses

Bands designed for specific types of restorations:

- Universal band—For restorations on all posterior teeth except for teeth with deep cervical restorations—Example: MO, DO, MOD
- Bands for teeth with deep cervical restorations—Example: Premolars that have a deep cervical restoration. Example: MO, DO, or MOD
- Bands for larger teeth with deep cervical restorations—Example: Larger teeth such as Molars that have a deep cervical restoration. Example: MO, DO, MOD

Variety of pediatric bands available for primary teeth

Practice Note

Matrix Bands are used on amalgam, composite, buildup, and temporary filling tray setups.

Sterilization Notes

Matrix Bands should be disposed of in a sharps container, and/or local and state regulations should be followed. Single use only.





Instrument

Matrix Band System

Function

To replace missing proximal wall or walls of cavity preparation for condensation of restorative material for class II preparations

Characteristics

Variety of matrix band systems (pictured: AutoMatrix)

Variety of sizes and shapes

Bands designed for specific teeth:

- Universal—Posterior teeth
- Molar—Larger molars
- Premolar
- Pediatric—Primary teeth

Practice Notes

Tightening wrench is used to place, tighten, and loosen bands.

Removing pliers are used to remove bands.

Matrix Bands are used on amalgam, composite, buildup, and temporary filling tray setups.

Sterilization Notes

Matrix Bands should be disposed of in sharps container, or local and state regulations should be followed. Single use only. Matrix Band Instruments should be placed in an open and unlocked position either in a sterilizing pouch with an internal process indicator, sealed, then sterilized OR wrapped with an internal process indicator inside and secured on the outside with process indicator tape, then sterilized. Verify appropriate color change has been achieved in external process indicator immediately after removal from sterilizer then check internal process indicator before treatment. Refer to state regulations for any additional state requirements.

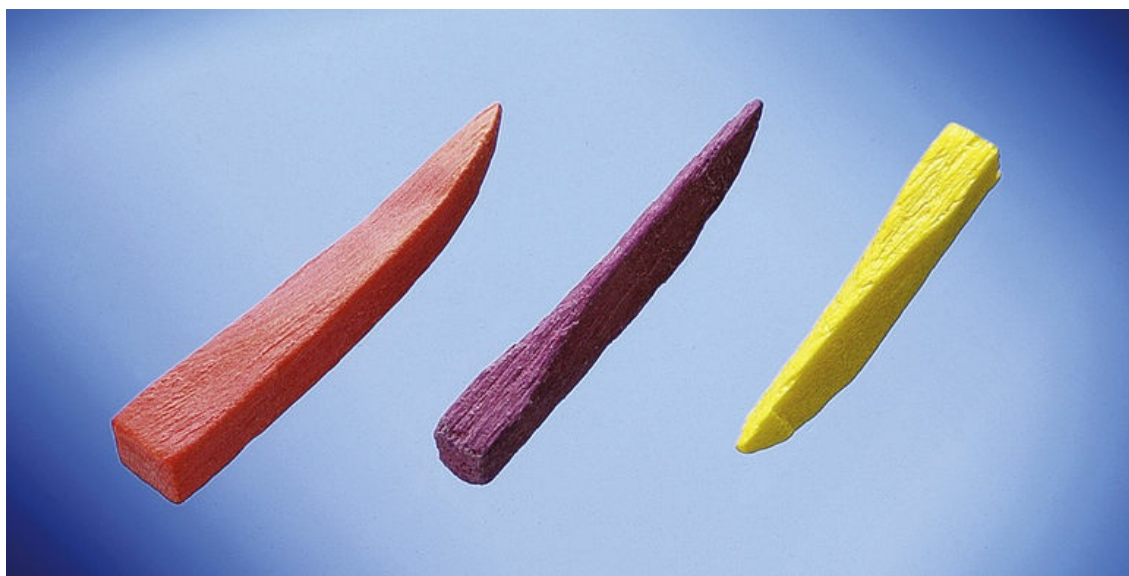

Instrument

Wooden Wedges

Function

To hold matrix band in place along gingival margin of class II, class III, or class IV preparation

Characteristics

Wood or plastic

Triangular, round, or anatomical shapes (shown in picture)

Variety of sizes and shapes available to accommodate embrasure area

Practice Notes

Wedges are placed in gingival embrasure area usually on the lingual.

Wedges are always set up with all types of matrix band systems for class II, class III, or class IV restorations.

Sterilization Notes

Wooden Wedges should be disposed of in the garbage. Single use only.

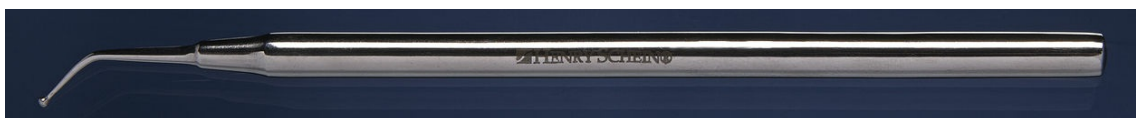

Instrument

Liner Applicator

Function

To place dental liner material (such as calcium hydroxide or glass ionomer) in cavity preparation

Characteristics

Short or long handle
Single or double ended

Practice Notes

Liner Applicator is used on amalgam, composite, crown and bridge, and temporary filling tray setups.

Also referred to as a Dycal instrument

Sterilization Notes

Liner Applicator must be precleaned, either, placed in a sterilizing pouch with an internal process indicator, sealed, then sterilized OR wrapped with an internal process indicator inside and secured on the outside with process indicator tape, then sterilized. Verify appropriate color change has been achieved in external process indicator immediately after removal from sterilizer then check internal process indicator before treatment. Refer to state regulations for any additional state requirements.

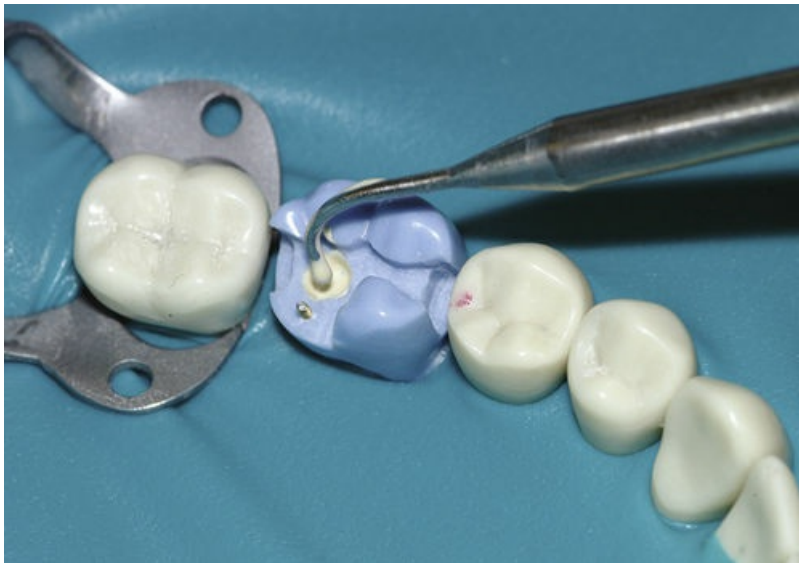

Instrument

Woodson

Functions

To carry and place temporary restorative material for cavity preparation—Paddle end
To condense restorative material—Plugger end
To carry (paddle end) and condense a base (Plugger end)

Characteristics

Double ended

Range of sizes available:

- Plugger end available in variety of sizes
- Paddle end available in different angles, sizes

Practice Notes

Woodson is used on amalgam, composite, crown and bridge, temporary filling, and provisional crown tray setups.

Sterilization Notes

Woodson must be precleaned, either, placed in a sterilizing pouch with an internal process indicator, sealed, then sterilized OR wrapped with an internal process indicator inside and secured on the outside with process indicator tape, then sterilized. Verify appropriate color change has been achieved in external process indicator immediately after removal from sterilizer then check internal process indicator before treatment. Refer to state regulations for any additional state requirements.



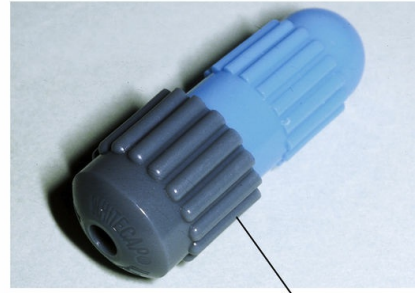

Instrument

Amalgamator and Amalgam Capsule

Functions

To mix alloy and mercury into amalgam in a capsule
To mix other types of restorative materials in a capsule
To mix preencapsulated permanent and temporary cements

Characteristics

- Amalgamator
- Preloaded amalgam capsules contain alloy, mercury, and pestle to aid mixing:
 - Various types of capsules are available; they are activated manually by twisting or pushing or using a capsule activator.

Thin membrane separates materials until mixing occurs.

Practice Notes

The process of mixing is called amalgamation or trituration.
The mixing time recommended by the manufacturer should be used.

Sterilization Notes

Capsules must be disposed of in the garbage, or state regulations must be followed. Single use only. Excess amalgam must be disposed of as amalgam waste material. Refer to local and state regulations for disposal. Amalgamator should be handled with overgloves or precleaned and disinfected according to the manufacturer's recommendation.



Instrument

Amalgam Well

Functions

To hold amalgam before it is placed in preparation
To hold amalgam while loading amalgam carrier

Characteristic

Metal (shown in picture), plastic, or glass

Practice Notes

Amalgam Well is used on the amalgam tray setup.

Sterilization Notes

Amalgam Well must be precleaned, either, placed in a sterilizing pouch with an internal process indicator, sealed, then sterilized OR wrapped with an internal process indicator inside and secured on the outside with process indicator tape, then sterilized. Verify appropriate color change has been achieved in external process indicator immediately after removal from sterilizer then check internal process indicator before treatment. Excess amalgam must be disposed of as amalgam waste material. Refer to local and state regulations for disposal.



Instrument

Amalgam Carrier

Function

To carry and dispense amalgam into cavity preparation

Characteristics

Single or double ended:

- Double ended—One small end and one large end
- Single ended—Plunger style

The inside of the hollow tubes is coated with metal or Teflon.

Practice Notes

Amalgam is packed in hollow tubes and then transferred to the cavity preparation. Amalgam sticks in the carrier if it is not released immediately after the tubes are filled. Amalgam Carrier is used exclusively on amalgam tray setups.

Sterilization Notes

Amalgam Carrier must be precleaned, either, placed in a sterilizing pouch with an internal process indicator, sealed, then sterilized OR wrapped with an internal process indicator inside and secured on the outside with process indicator tape, then sterilized. Verify appropriate color change has been achieved in external process indicator immediately after removal from sterilizer then check internal process indicator before treatment. Refer to state regulations for any additional state requirements. Excess amalgam must be disposed of as amalgam waste material. Refer to local and state regulations for disposal.

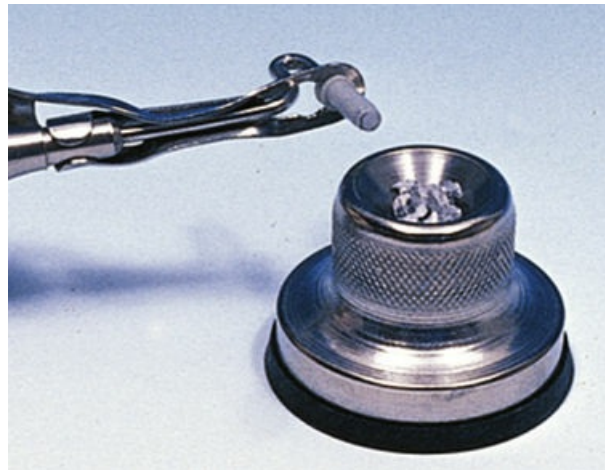



Instrument

Condenser (Plugger)—Smooth and Serrated

Functions

- To pack and condense amalgam into cavity preparation
- To pack and condense other restorative materials
- To pack and condense temporary filling material

Characteristics

- Smooth end small
- Smooth end large
- Serrated ends

Round, flat, or diamond shaped

Single or double ended

- Double ended—One small end and one large end

Back action condenser available with right-angle working ends—Accommodates difficult areas
Range of sizes available

Practice Notes

Smooth and Serrated Condensers are used on amalgam, composite, and temporary filling tray setups.

Sterilization Notes

Smooth and Serrated Condensers must be precleaned, either, placed in a sterilizing pouch with an internal process indicator, sealed, then sterilized OR wrapped with an internal process indicator inside and secured on the outside with process indicator tape, then sterilized. Verify appropriate color change has been achieved in external process indicator immediately after removal from sterilizer then check internal process indicator before treatment. Refer to state regulations for any additional state requirements. Excess amalgam must be disposed of as amalgam waste material. Refer to local and state regulations for disposal.





Instrument

Interproximal Condenser

Functions

To pack and condense amalgam into interproximal areas of cavity preparation
To pack and condense other restorative materials

Characteristics

Ends shaped to fit mesial or distal areas of cavity preparation
Smooth or serrated ends
Range of sizes available

Practice Note

Interproximal Condenser is used on amalgam, composite, and temporary filling tray setups.

Sterilization Notes

Interproximal Condenser must be precleaned, either, placed in a sterilizing pouch with an internal process indicator, sealed, then sterilized OR wrapped with an internal process indicator inside and secured on the outside with process indicator tape, then sterilized. Verify appropriate color change has been achieved in external process indicator immediately after removal from sterilizer then check internal process indicator before treatment. Refer to state regulations for any additional state requirements. Excess amalgam must be disposed of as amalgam waste material. Refer to local and state regulations for disposal.

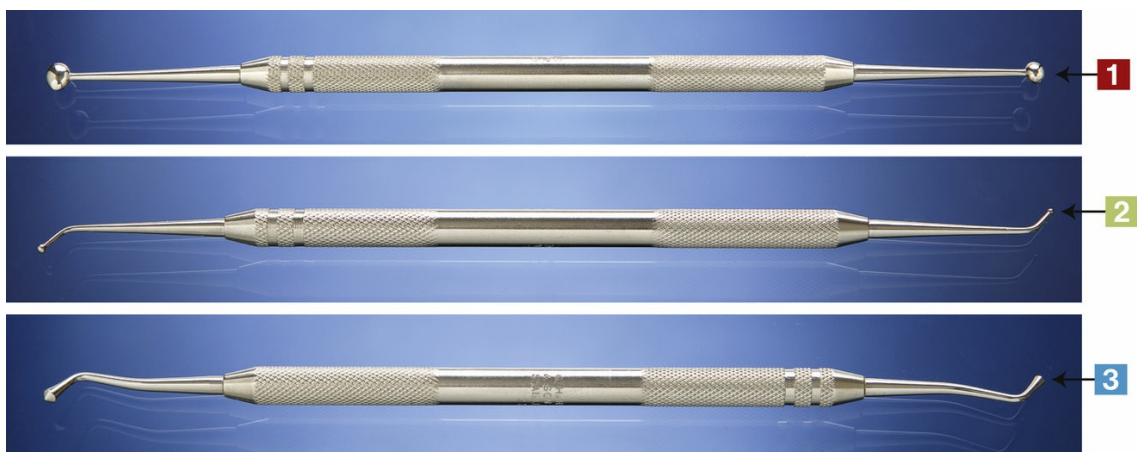

Instrument

Burnishers—Football, Ball, and Acorn

Functions

- To smooth amalgam after condensing
- To contour matrix band before placement
- To perform initial shaping of amalgam
- To burnish restorative material
- To burnish temporary filling material

Characteristics

- Football burnisher
- Ball burnisher
- Acorn burnisher

Single or double ended—some double ended burnishers may have two different types of burnishers

Practice Note

Football, Ball, and Acorn Burnishers are used on amalgam, composite, and temporary filling tray setups.

Sterilization Notes

Football, Ball, and Acorn Burnishers must be precleaned, either, placed in a sterilizing pouch with an internal process indicator, sealed, then sterilized OR wrapped with an internal process indicator inside and secured on the outside with process indicator tape, then sterilized. Verify appropriate color change has been achieved in external process indicator immediately after removal from sterilizer then check internal process indicator before treatment. Refer to state regulations for any additional state requirements. Excess amalgam must be disposed of as amalgam waste material. Refer to local and state regulations for disposal.

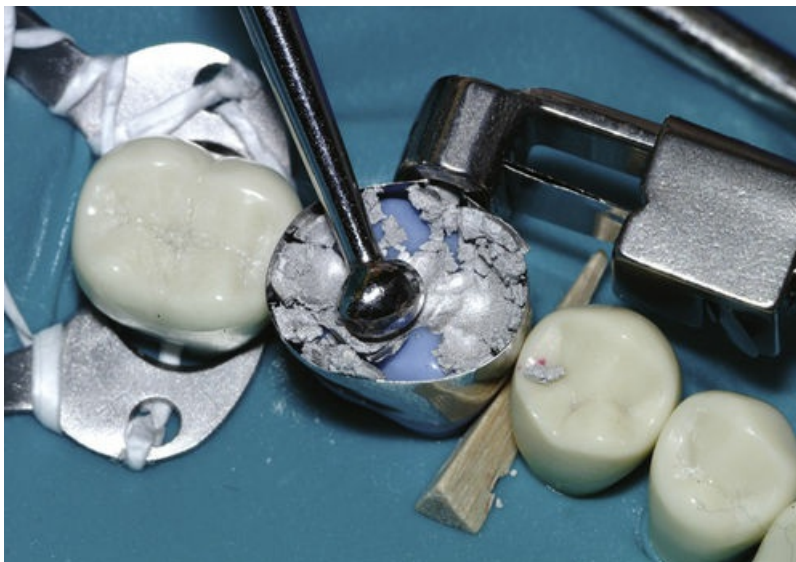



Instrument

T-Ball Burnisher

Functions

- To smooth amalgam after condensing
- To contour matrix band before placement
- To begin shaping of amalgam
- To burnish restorative materials
- To burnish temporary filling material

Characteristic

Single ended

Practice Notes

T-Ball Burnisher is used on amalgam, composite, and temporary filling tray setups.

Sterilization Notes

T-Ball Burnisher must be precleaned, either, placed in a sterilizing pouch with an internal process indicator, sealed, then sterilized OR wrapped with an internal process indicator inside and secured on the outside with process indicator tape, then sterilized. Verify appropriate color change has been achieved in external process indicator immediately after removal from sterilizer then check internal process indicator before treatment. Refer to state regulations for any additional state requirements. Excess amalgam must be disposed of as amalgam waste material. Refer to local and state regulations for disposal.



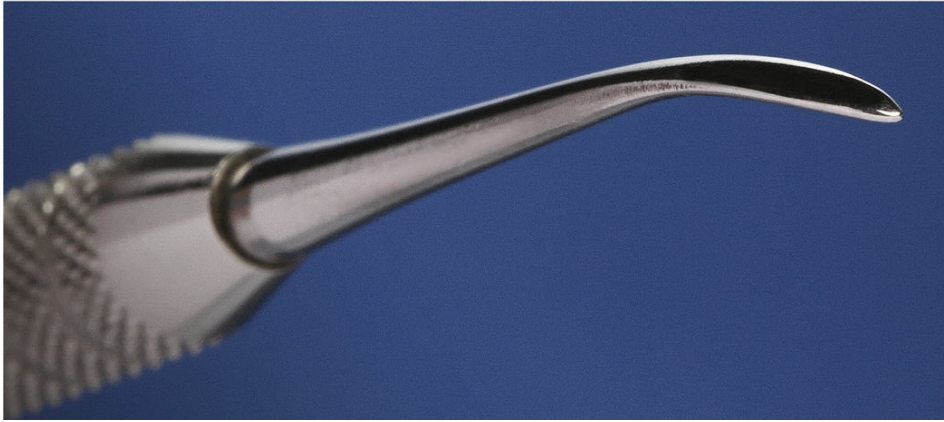

Instrument

Beavertail Burnisher

Functions

- To smooth amalgam after condensing
- To perform initial shaping and/or carving of amalgam
- To invert dental dam (refer to dental dam tray setup in [Chapter 7](#))
- To burnish restorative materials
- To burnish temporary filling material

Characteristic

Single or double ended

Practice Note

Beavertail Burnisher is used on amalgam, temporary filling, and dental dam tray setups.

Sterilization Notes

Beavertail Burnisher must be precleaned, either, placed in a sterilizing pouch with an internal process indicator, sealed, then sterilized OR wrapped with an internal process indicator inside and secured on the outside with process indicator tape, then sterilized. Verify appropriate color change has been achieved in external process indicator immediately after removal from sterilizer then check internal process indicator before treatment. Refer to state regulations for any additional state requirements. Excess amalgam must be disposed of as amalgam waste material. Refer to local and state regulations for disposal.



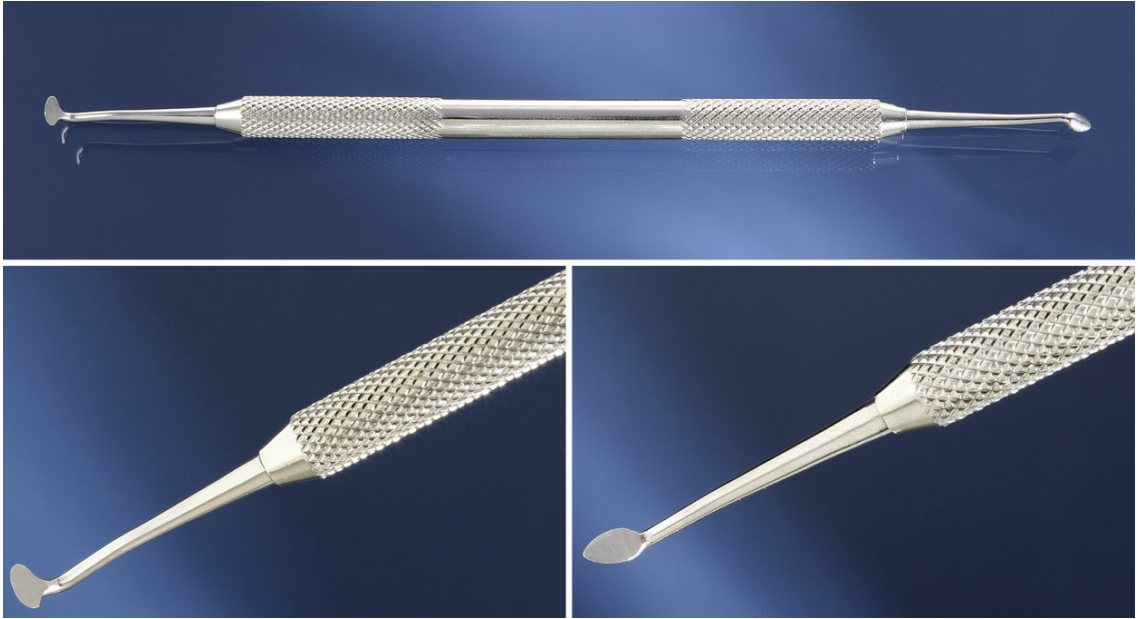

Instrument

Tanner Carver

Functions

To carve occlusal anatomy into amalgam restorations

To carve occlusal anatomy in other restorative and temporary filling materials

Characteristics

Double ended – Two ends shaped differently

Ends shaped differently from those of discoid-cleoid carver

Practice Notes

Tanner Carver is used on amalgam and temporary filling tray setups.

Sterilization Notes

Tanner Carver must be precleaned, either, placed in a sterilizing pouch with an internal process indicator, sealed, then sterilized OR wrapped with an internal process indicator inside and secured on the outside with process indicator tape, then sterilized. Verify appropriate color change has been achieved in external process indicator immediately after removal from sterilizer then check internal process indicator before treatment. Refer to state regulations for any additional state requirements. Excess amalgam must be disposed of as amalgam waste material. Refer to local and state regulations for disposal.

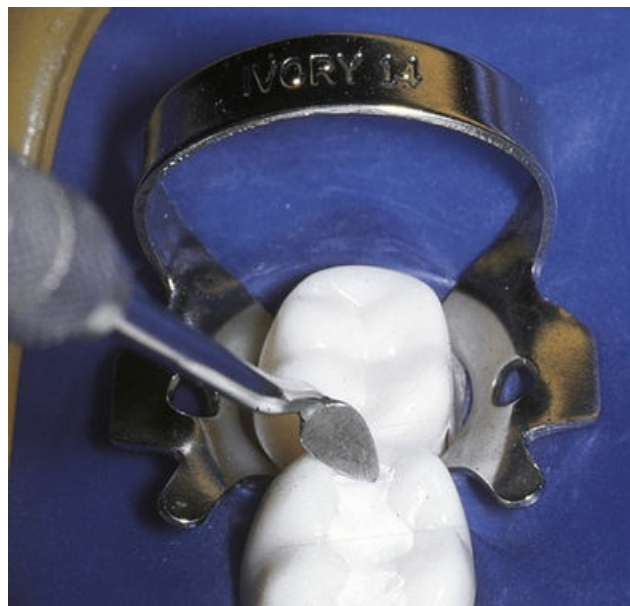

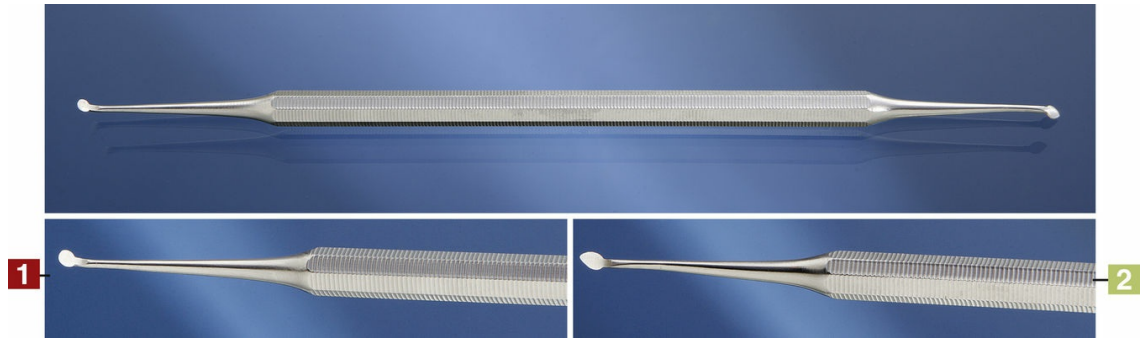

Instrument

Discoid-Cleoid Carver

Functions

To carve occlusal anatomy into amalgam restorations

To carve occlusal anatomy in other restorative and temporary filling materials

Characteristics

Double ended – Two ends shaped differently:

- Discoid end – Disc shaped
- Cleoid end – Pointed

Ends shaped differently from those of Tanner carver

Practice Notes

Discoid-Cleoid Carver is used on amalgam and temporary filling tray setups.

Sterilization Notes

Discoid-Cleoid Carver must be precleaned, either, placed in a sterilizing pouch with an internal process indicator, sealed, then sterilized OR wrapped with an internal process indicator inside and secured on the outside with process indicator tape, then sterilized. Verify appropriate color change has been achieved in external process indicator immediately after removal from sterilizer then check internal process indicator before treatment. Refer to state regulations for any additional state requirements. Excess amalgam must be disposed of as amalgam waste material. Refer to local and state regulations for disposal.

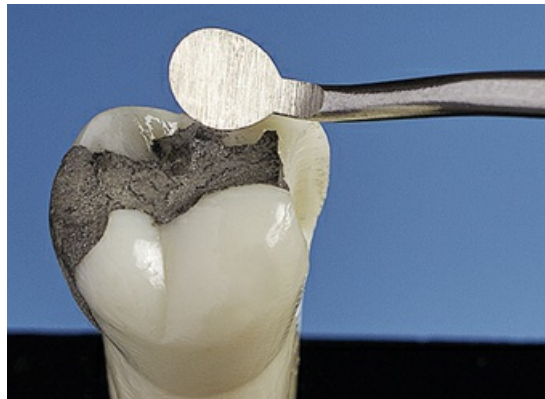

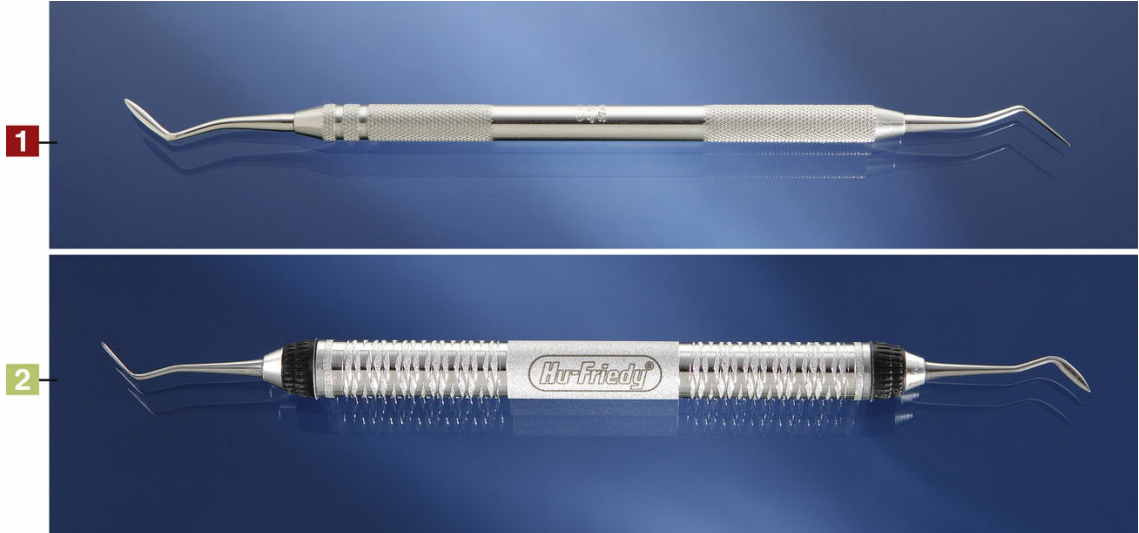

Instrument

Hollenback and Half-Hollenback Carvers

Functions

To contour and carve occlusal and interproximal anatomy in amalgam restorations

To contour and carve occlusal and interproximal anatomy in other restorative and temporary filling materials

Characteristics

- Hollenback
 - Half-Hollenback—Half the size of Hollenback carver
- Double ended—Working ends protrude at different angles.

Practice Note

Hollenback and Half-Hollenback Carvers are used on amalgam, composite, and temporary filling tray setups.

Sterilization Notes

Hollenback and Half-Hollenback Carvers must be precleaned, either, placed in a sterilizing pouch with an internal process indicator, sealed, then sterilized OR wrapped with an internal process indicator inside and secured on the outside with process indicator tape, then sterilized. Verify appropriate color change has been achieved in external process indicator immediately after removal from sterilizer then check internal process indicator before treatment. Refer to state regulations for any additional state requirements. Excess amalgam must be disposed of as amalgam waste material. Refer to local and state regulations for disposal.

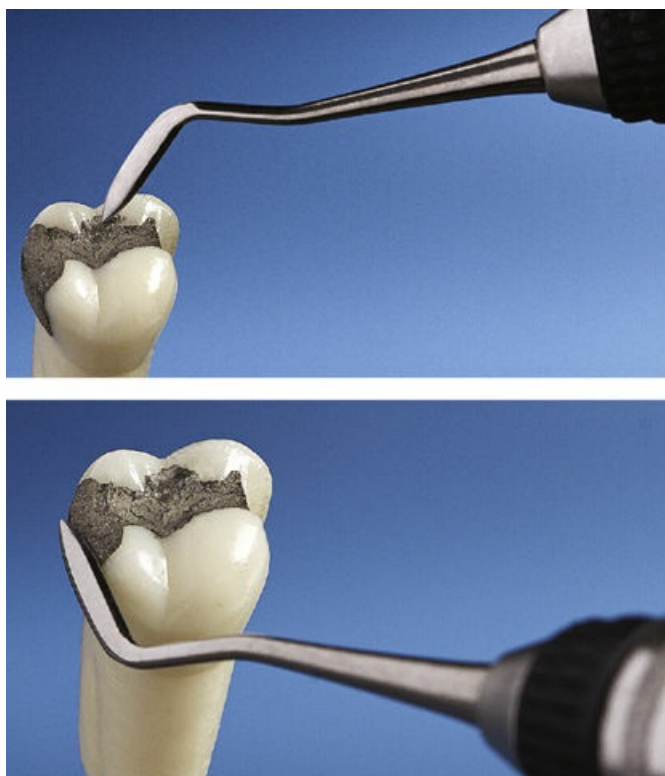

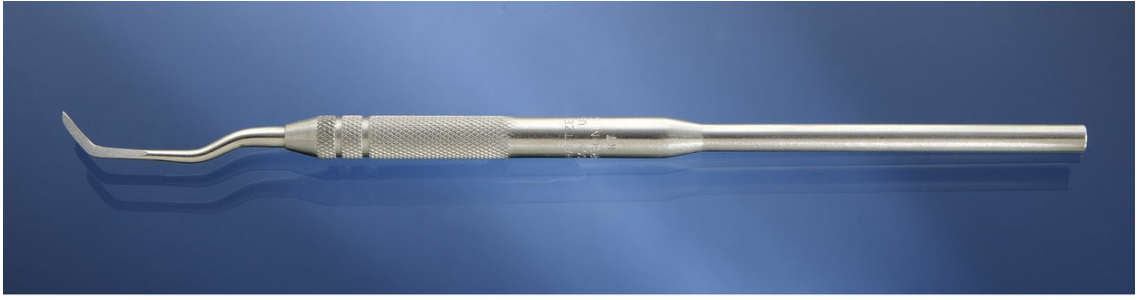

Instrument

Gold Carving Knife

Functions

- To trim interproximal amalgam restoration, recreating contour of proximal wall(s)
- To trim interproximal restorations with other restorative materials, recreating contour of proximal wall(s)
- To remove flash composite material from interproximal areas

Characteristics

- Single or double ended
- Variety of designs
- Interproximal carving knife-Different Styles available as shown above

Practice Notes

Gold Carving Knife is used on amalgam and composite restorative tray setups.

Sterilization Notes

Gold Carving Knife must be precleaned, either, placed in a sterilizing pouch with an internal process indicator, sealed, then sterilized OR wrapped with an internal process indicator inside and secured on the outside with process indicator tape, then sterilized. Verify appropriate color change has been achieved in external process indicator immediately after removal from sterilizer then check internal process indicator before treatment. Refer to state regulations for any additional state requirements. Excess amalgam must be disposed of as amalgam waste material. Refer to local and state regulations for disposal.



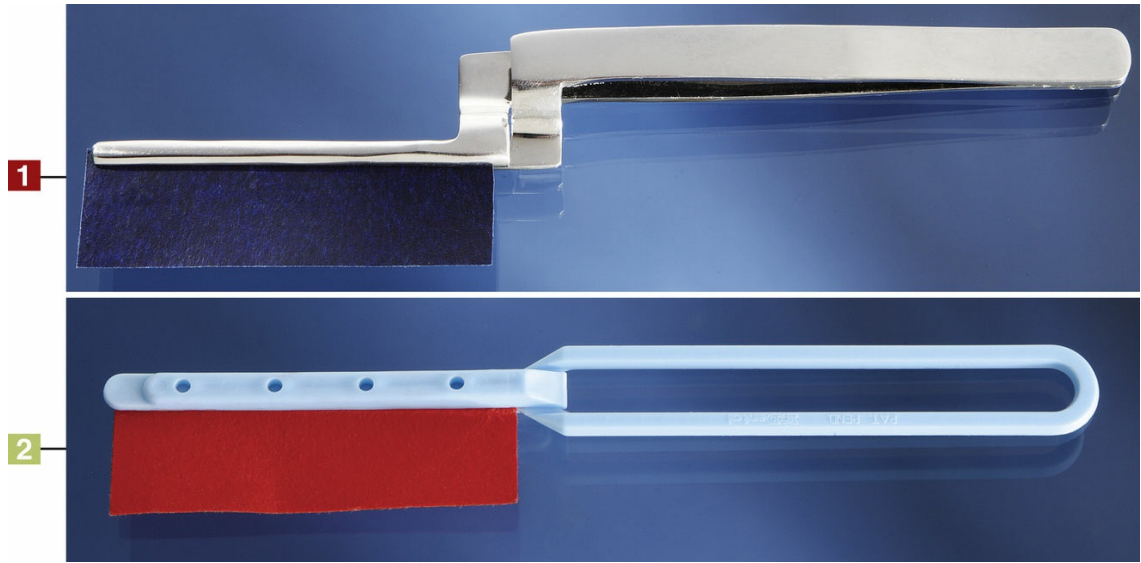

Instrument

Articulating Paper Holder

Functions

To hold articulating paper in place
To check centric and lateral occlusion

Characteristics

- Metal articulating paper holder
 - Disposable articulating paper holder
- Articulating paper—blue (top) or red (bottom)
Paper variety—from thin to thick

Practice Notes

Articulating Paper Holder and articulating paper are used on all restorative tray setups, including but not limited to amalgam, composite, fixed and removable prosthodontics, provisional crown, endodontics, orthodontic retainer delivery, and temporary filling tray setups.

Sterilization Notes

Articulating Paper Holder (metal type) must be precleaned, either, placed in a sterilizing pouch with an internal process indicator, sealed, then sterilized OR wrapped with an internal process indicator inside and secured on the outside with process indicator tape, then sterilized. Verify appropriate color change has been achieved in external process indicator immediately after removal from sterilizer then check internal process indicator before treatment. Refer to state regulations for any additional state requirements. Disposable Articulating Paper Holder and Articulating Paper should be disposed of in the garbage. Single use only. Excess amalgam must be disposed of as amalgam waste material. Refer to local and state regulations for disposal.





Tray Setup

Amalgam

Top Row (Left to Right)

Amalgam well, HVE tip, burs in bur block, amalgam carrier-plunger style (very top of tray)

Bottom Row (Left to Right)

Mouth mirror, explorer, cotton forceps (pliers), spoon excavator, enamel hatchet, mesial gingival margin trimmer, distal gingival margin trimmer, small condenser, large condenser, acorn burnisher, Tanner carver, half-Hollenback carver, gold carving knife, Tofflemire, wooden wedges, crown and bridge scissors, articulating paper holder and articulating paper, liner applicator, dental floss, anesthetic aspirating syringe, air/water syringe tip

Sterilization Notes

Refer to each individual picture for correct procedure for instrument sterilization or disposal of instrument or material. Refer to other chapters for additional instruments on this tray setup that are not included in this chapter.

Composite Restorative Instruments

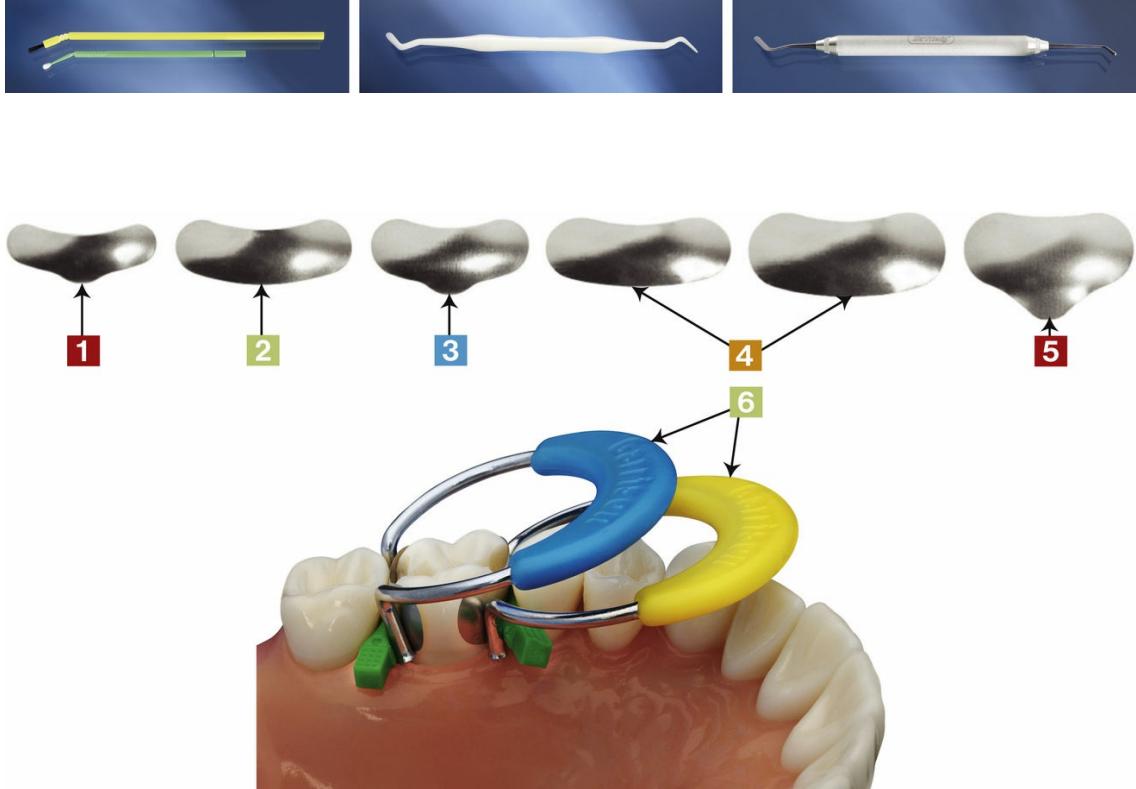

Instrument

Sectional Matrix System

Function

To replace missing proximal wall of cavity preparation for placement of composite material or other restorative materials for class II restorations

Characteristics

Variety of sizes and shapes to accommodate restoration:

- Pediatric band – Primary molar
- Small band – Premolar, small molar
- Extended small band – Premolar, molar, with deep cervical restoration
- Standard band – Molar restoration
- Large band – Deep cervical restoration
- Tension rings – Different sizes to accommodate restoration

Placed to secure band on proximal wall

Placed on tooth with dental dam forceps (Refer to page 170, Chapter 7)

Practice Notes

Sectional Bands are used on amalgam, composite, buildup, and temporary filling tray setups. Classes III and IV composite restorations use a clear Mylar matrix strip.

Sterilization Notes

Sectional Bands should be disposed of in sharps container, or state regulations should be followed. Single use only. Tension rings must be precleaned, either, placed in a sterilizing pouch with an internal process indicator, sealed, then sterilized OR wrapped with an internal process indicator inside and secured on the outside with process indicator tape, then sterilized. Verify appropriate color change has been achieved in external process indicator immediately after removal from sterilizer then check internal process indicator before treatment. Refer to state regulations for any additional state requirements.

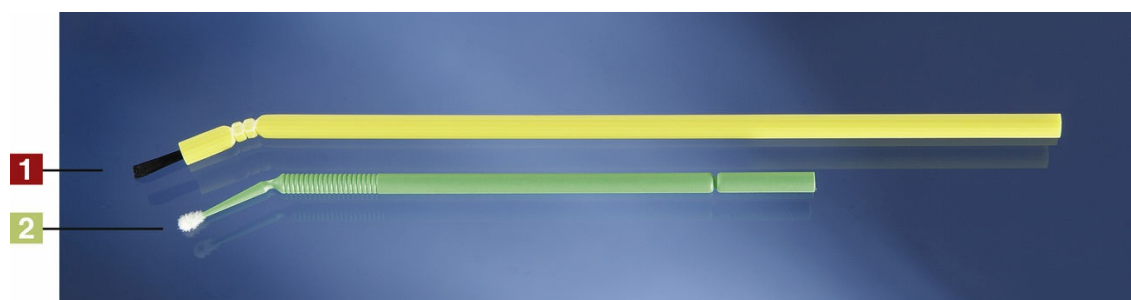

Instrument

Applicator

Functions

To apply conditioning, primer, and bonding material to cavity preparation
To use with bonding procedures, sealants, and orthodontic band brackets

Characteristics

Types:

- Disposable One-piece Applicator—Several colors available for application of different materials; working end bends; various styles, sizes
- Microbrush Applicator—Disposable, various styles, sizes

Practice Notes

Applicators are used on composite, sealant tray setups and any procedure involving etching, primers, and bonding materials.

Sterilization Notes

Disposable Applicator(s) should be disposed of in the garbage. Single use only.





Instrument

Well for Composite Material

Function

To hold material: etchant, primers, bonding, and composite

Characteristics

- Disposable (pictured) or autoclavable
- Well with protective light cover

Labels on each well—Designate different materials

Variety of styles and colors available

Practice Notes

Wells are also used on a sealant tray setup and any procedure involving etching, primers, and bonding.

Sterilization Notes

Disposable Wells should be disposed of in the garbage. Must be precleaned, either, placed in a sterilizing pouch with an internal process indicator, sealed, then sterilized OR wrapped with an internal process indicator inside and secured on the outside with process indicator tape, then sterilized. Verify appropriate color change has been achieved in external process indicator immediately after removal from sterilizer then check internal process indicator before treatment. Refer to state regulations for any additional state requirements. Refer to manufacturer's recommendations.

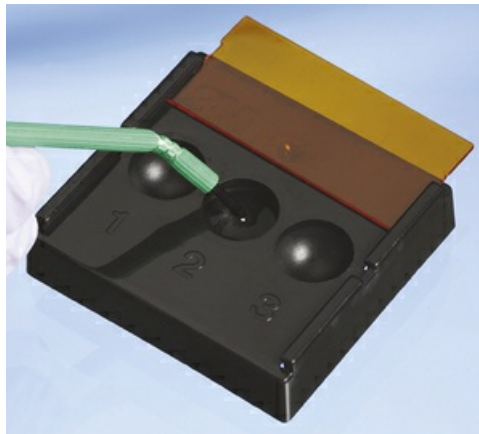



Instrument

Composite Placement Instrument

Functions

To carry composite material to the cavity preparation

To place, condense, and carve composite material in cavity preparation

Characteristics

- Plastic composite instrument—Plastic that can be sterilized
- Metal composite instruments—Titanium nitride coating

Double ended

Different angles on ends

Ends shaped differently, one to accommodate initial placement of material (paddle end) and the other end to condense, contour, and carve material

Variety of sizes, shapes, and angles available

Practice Notes

Composite Placement Instrument is used on composite tray setups.

Sterilization Notes

Composite Placement Instrument must be precleaned, either, placed in a sterilizing pouch with an internal process indicator, sealed, then sterilized OR wrapped with an internal process indicator inside and secured on the outside with process indicator tape, then sterilized. Verify appropriate color change has been achieved in external process indicator immediately after removal from sterilizer then check internal process indicator before treatment. Refer to state regulations for any additional state requirements.





Instrument

Composite Burnisher

Functions

To form occlusal anatomy in composite restorations

To achieve final contouring of anatomy, pits, fissures, and grooves

Characteristics

Double ended—Different angle on either end

- Composite Burnisher: Titanium nitride coating—Creates hard, smooth, nonstick surface that resists scratching, sticking, or discoloration of composite material

- Acorn Burnisher (for composite restorations):

Gold titanium nitride coating—Creates hard, smooth, nonstick surface that resists scratching, sticking, or discoloration of composite material

Practice Notes

Composite Burnisher is used on composite tray setups.

Sterilization Notes

Composite Burnisher must be precleaned, either, placed in a sterilizing pouch with an internal process indicator, sealed, then sterilized OR wrapped with an internal process indicator inside and secured on the outside with process indicator tape, then sterilized. Verify appropriate color change has been achieved in external process indicator immediately after removal from sterilizer then check internal process indicator before treatment. Refer to state regulations for any additional state requirements.





Instrument

Curing Light—Battery Operated

Function

To harden light-cured materials: bonding agents, composite, sealants, buildup material

Characteristics

Battery operated—Includes battery charger with extra battery

Practice Notes

Material must be cured in increments of 2 mm or less to ensure complete setting. Refer to manufacturer's recommendation for curing time.

Sterilization Notes

A testing device should be used to check the accuracy of the Curing Light. Protective sleeves are available for the curing lights. Pre-clean and disinfect the wand and light using disinfectant solution according to the manufacturer's recommendation.





Instrument

Protective Shield for Curing Light

Function

To protect eyes during curing stage of light-cured material

Characteristics

Orange color—Blocks harmful light to operator/assistant and patient's eyes
Protective shields also available on curing light (see [Curing Light](#), page 242)

- Paddle Shield style
- Protective eyeglasses available for operator, assistant, and patient

Practice Notes

Protective Shield must be used with all curing lights.

Sterilization Notes

Protective Shield, paddle, glasses must be precleaned and disinfected according to the manufacturer's recommendation.





Instrument

LED and Halogen Radiometers

Functions

To accurately test the visible light output for the LED and halogen curing lights
To determine the accuracy of the LED and halogen lights that cure dental materials

Characteristics

White—Halogen Radiometer
Blue—LED Radiometer

Practice Notes

Loss of output of the curing lights will affect the amount of time needed to efficiently cure dental material.
Lights should be tested periodically to ensure lightbulb and battery are working efficiently.

Sterilization Notes

Refer to manufacturer's recommendation for disinfecting Radiometers.

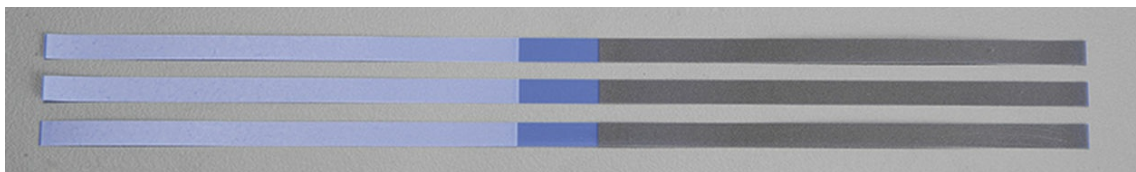

Instrument

Finishing Strip

Function

To finish and smooth interproximal surface of restoration

Characteristics

Abrasive textures available: synthetic or sandpaper material

Different grit consistencies available

Different grit consistency is on either end of strip—see color difference.

Practice Notes

Synthetic Finishing Strip—No abrasive material in center of strip; helps avoid removal of tooth structure while inserting the finishing strip interproximally.

Finishing Strip is used on composite and amalgam tray setups.

Sterilization Notes

Finishing Strip should be disposed of in the garbage. Single use only.





Tray Setup

Composite Procedure—Class III and Class IV Composite Restorative

Top Row (From Left to Right)

High-volume evacuator (HVE) tip, well for composite material, burs and mandrel or discs in bur block, shade guide

Bottom Row (From Left to Right)

Mouth mirror, explorer, cotton forceps (pliers), spoon excavator, composite placement instrument (titanium nitride coating), composite placement instrument (plastic), gold carving knife, liner applicator, three different colors of applicator brushes, wooden wedges, clear Mylar matrix strip and clamp to hold matrix, crown and bridge scissors, articulating paper holder and articulating paper, dental floss, anesthetic aspirating syringe, air/water syringe tip

Sterilization Notes

Refer to each picture for correct procedure for instrument sterilization or disposal of material. Refer to other chapters for additional instruments on this tray setup that are not included in this chapter.



Tray Setup

Composite Procedure—Class I, Class II, and Class V Composite Restorative

Top Row (Left to Right)

Articulating paper holder and articulating paper, well for composite material, shade guide

Bottom Row (Left to Right)

Mouth mirror, explorer, cotton forceps (pliers), spoon excavator, composite placement instrument (titanium nitride coating), composite placement instrument (plastic), composite burnisher (gold–titanium nitride coating), gold carving knife, liner applicator, three different colors of applicator brushes, high-volume evacuator (HVE) tip, anesthetic syringe, dental dam forceps used for tension rings, (under forceps: matrix band, wooden wedges, tension rings, burs, mandrel/discs in bur block), dental floss, air/water syringe tip

Bottom of Tray

Finishing strip

Sterilization Notes

Refer to each picture for correct procedure for instrument sterilization or disposal of material. Refer to other chapters for additional instruments on this tray setup that are not included in this chapter.

Fixed Prosthodontics Restorative Instruments



Instrument

Facebow

Functions

To establish the centric relationship of the maxillary teeth to the mandibular teeth
To establish the position of the teeth when the temporal mandibular joint is aligned correctly

Characteristics

Recording and establishing the centric occlusion assists in fabricating fixed prosthodontic restorations

- Apply compound tabs or dental impression material on bite fork

Recording and establishing the centric occlusion assists in fabricating fixed and removable prosthodontic appliances

Example

Crowns, bridges, partials and dentures.

Facebows are also used with orthodontic treatment assessment for mounting the impressions in correct occlusion

Practice Notes

Facebow transfer applications are used in all phases of restorative dentistry.

Sterilization Notes

Facebow outer appliances must be disinfected according to the manufacturer's recommendation. Bite Fork must be precleaned, either, placed in a sterilizing pouch with an internal process indicator, sealed, then sterilized OR wrapped with an internal process indicator inside and secured on the outside with process indicator tape, then sterilized. Verify appropriate color change has been achieved in external process indicator immediately after removal from sterilizer then check internal process indicator before treatment. Refer to state regulations for any additional state requirements.





Instrument

Shade Guides/Digital Color Imaging

Functions

To select a shade for permanent fixed restorations

Example

Crowns, veneers, bridges

To select a shade for removable appliances

Example

Partials, dentures

Characteristics

- Many different shade guides are available.
- Many different digital or computerized shade guides are available.

Practice Notes

Each tooth may have different shades: one for the gingival third, one for the body or middle third, and one for the incisal edge (usually needed for anteriors).

Sterilization Notes

Shade Guides must be disinfected according to the manufacturer's recommendation.



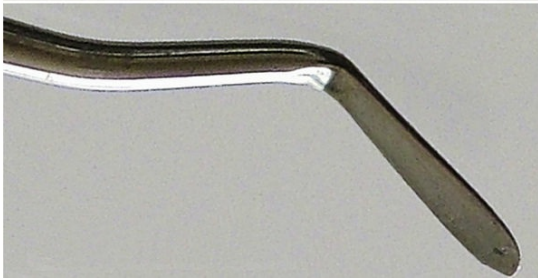

Instrument

Gingival Retraction Cord Instrument

Function

To place gingival retraction cord in sulcus area after tooth is prepared for a crown and before final impressions are taken

Characteristics

Smooth or serrated edges
Double ended—Different angle on each end
Variety of styles

Practice Notes

Gingival Retraction Cord instrument is mainly used on crown and bridge tray setup unless gingiva needs to be retracted for a restorative procedure.

Sterilization Notes

Gingival Retraction Cord Instrument must be precleaned, either, placed in a sterilizing pouch with an internal process indicator, sealed, then sterilized OR wrapped with an internal process indicator inside and secured on the outside with process indicator tape, then sterilized. Verify appropriate color change has been achieved in external process indicator immediately after removal from sterilizer then check internal process indicator before treatment. Refer to state regulations for any additional state requirements. Gingival retraction cord instrument should be disposed of in the garbage.

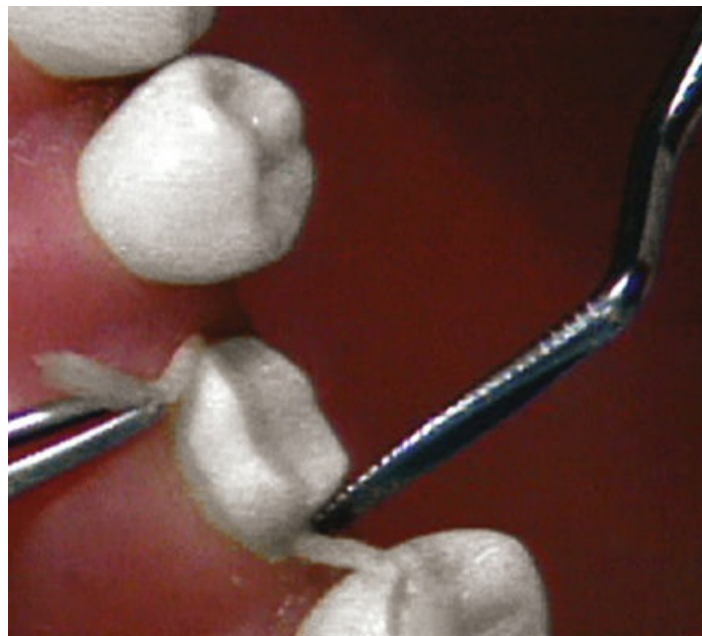



Instrument

Crown and Bridge Scissors

Functions

- To trim aluminum temporary crowns on gingival side
- To trim custom temporary crowns
- To cut gingival retraction cord
- To trim matrix bands
- To cut dental dam septum

Characteristics

- Short cutting edges—can be straight or curved, narrow or wide
- Variety of sizes

Practice Notes

Crown and Bridge Scissors are used on other restorative tray setups.

Sterilization Notes

Crown and Bridge Scissors must be precleaned open and unlocked, placed in an open and unlocked position either in a sterilizing pouch with an internal process indicator, sealed, then sterilized OR wrapped with an internal process indicator inside and secured on the outside with process indicator tape, then sterilized. Verify appropriate color change has been achieved in external process indicator immediately after removal from sterilizer then check internal process indicator before treatment. Refer to state regulations for any additional state requirements.

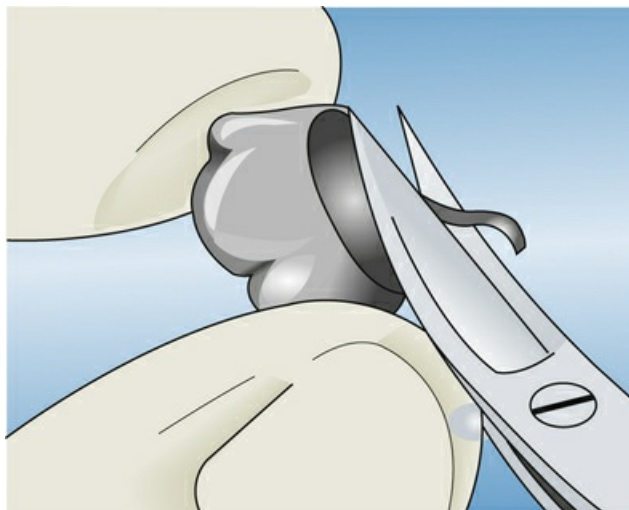



Instrument

Contouring Pliers

Function

To crimp and contour marginal edge of temporary crown or stainless steel crown

Characteristics

Commonly used type: Johnson
Range of sizes available

Practice Notes

Contouring Pliers are mainly used on crown and bridge tray setup.

Sterilization Notes

Contouring Pliers must be precleaned open and unlocked, placed in an open and unlocked position either in a sterilizing pouch with an internal process indicator, sealed, then sterilized OR wrapped with an internal process indicator inside and secured on the outside with process indicator tape, then sterilized. Verify appropriate color change has been achieved in external process indicator immediately after removal from sterilizer then check internal process indicator before treatment. Refer to state regulations for any additional state requirements.





Instrument

Provisional Crown–Removing Forceps

Function

To remove provisional crown from tooth

Characteristic

Range of sizes available

Practice Notes

Provisional Crown–Removing Forceps are mainly used on crown and bridge tray setup.

Sterilization Notes

Provisional Crown–Removing Forceps must be precleaned open and unlocked, placed in an open and unlocked position either in a sterilizing pouch with an internal process indicator, sealed, then sterilized OR wrapped with an internal process indicator inside and secured on the outside with process indicator tape, then sterilized. Verify appropriate color change has been achieved in external process indicator immediately after removal from sterilizer then check internal process indicator before treatment. Refer to state regulations for any additional state requirements.

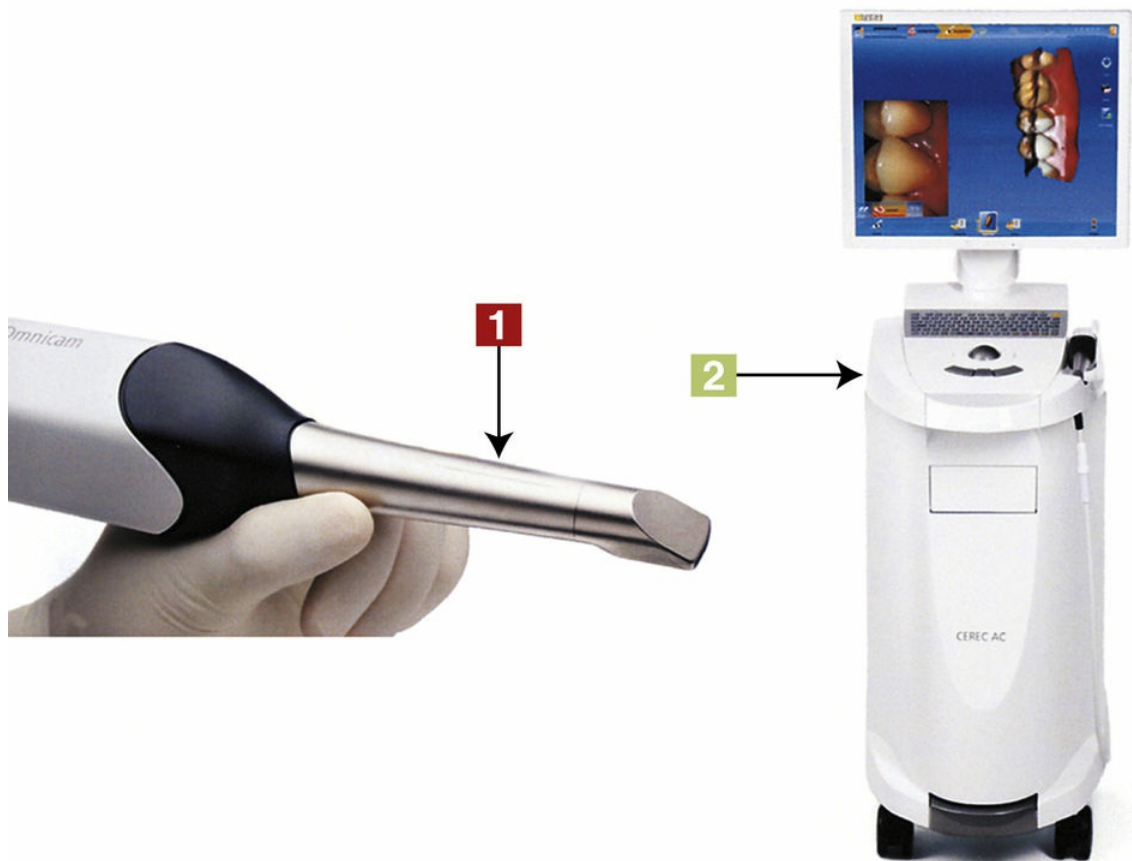

Instrument

CAD/CAM Machine

Functions

- To take a computer image of a tooth with an intraoral wand that connects to a computer
- To construct the anatomy, gingival margins, occlusal and mesial/distal contacts of the crown on the computer
- To send the information to the unit to construct the crown

Characteristics

- Camera
 - CAD/CAM in-office system with attached camera
- Crown is made of porcelain or other type materials.

Practice Notes

The CAD/CAM machine allows the patient to have one appointment for preparing and seating a crown.

Sterilization Notes

Barriers should be used for the intraoral wand. Barriers or overgloves should be used for manipulating the computer on the CAD/CAM-CEREC Machine. Otherwise, refer to the manufacturer's recommendation for disinfecting.

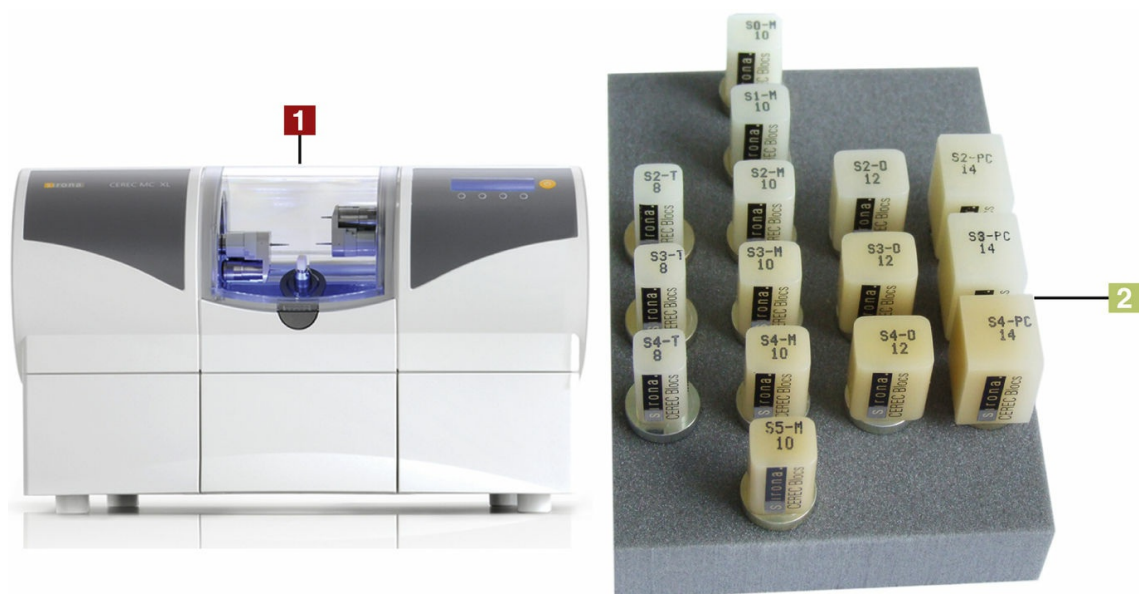

Instrument

CAD/CA Milling Machine

Functions

To mill the crown with the image taken from the camera that connects to the CAD/CAM

Characteristics

- Milling machine
 - Ceramic blocks that are placed in the milling machine to fabricate the crown
- As shown different shades are available.

Practice Notes

CAD/CAM machine allows the patient to have one appointment for preparing and seating a crown.

Sterilization Notes

Refer to manufacturer's recommendation for disinfecting.



Instrument

Wooden Bite Stick

Function

To seat permanent crown while patient bites in centric occlusion

Characteristics

Soft wood
Range of sizes available

Practice Notes

Wooden Bite Stick is primarily used on crown and bridge tray setup.
Other styles of biting devices to seat a crown are available including disposable devices

Sterilization Notes

Wooden Bite Stick must be precleaned, either, placed in a sterilizing pouch with an internal process indicator, sealed, then sterilized OR wrapped with an internal process indicator inside and secured on the outside with process indicator tape, then sterilized. Verify appropriate color change has been achieved in external process indicator immediately after removal from sterilizer then check internal process indicator before treatment. Refer to state regulations for any additional state requirements.
OR Wooden Bite Stick and other seating devices should be disposed of in the garbage.



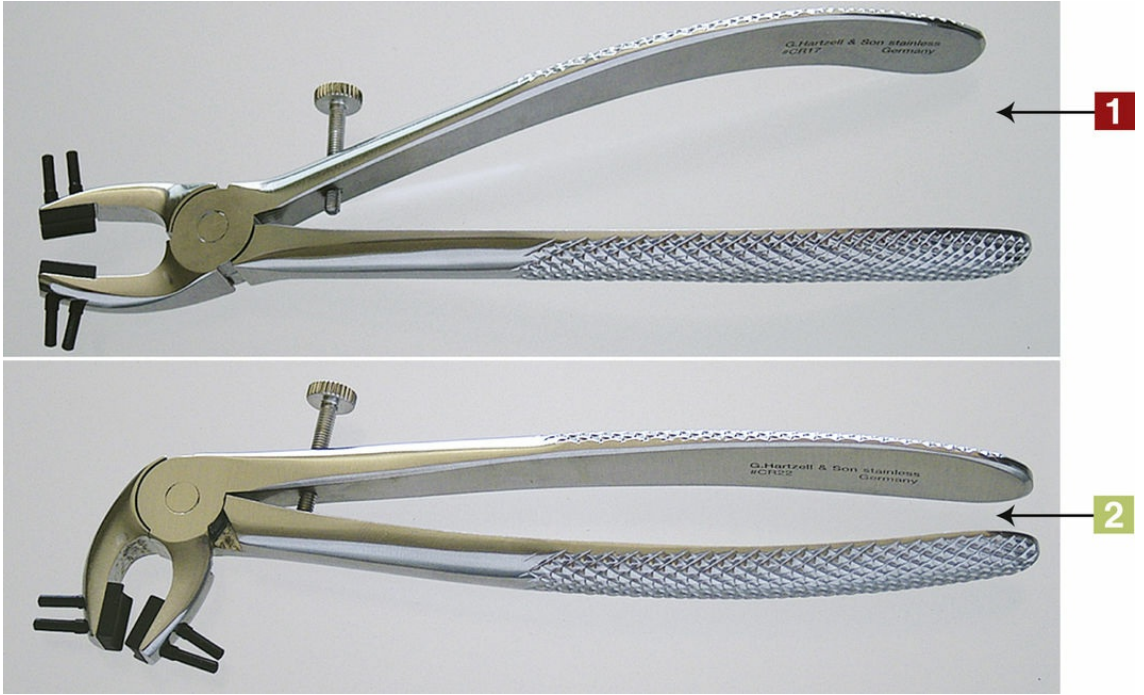

Instrument

Trial Crown Remover

Functions

To remove permanent crown from tooth during try-in phase
To remove provisional crown

Characteristics

Types:

- Maxillary trial crown remover
- Mandibular trial crown remover

Replaceable pads—Provide nonslipping, tight grip

Practice Notes

Trial Crown Remover is mainly used on crown and bridge tray setup.

Sterilization Notes

Trial Crown Remover must be precleaned open and unlocked, placed in an open and unlocked position either in a sterilizing pouch with an internal process indicator, sealed, then sterilized OR wrapped with an internal process indicator inside and secured on the outside with process indicator tape, then sterilized. Verify appropriate color change has been achieved in external process indicator immediately after removal from sterilizer then check internal process indicator before treatment. Refer to state regulations for any additional state requirements.



Tray Setup

Crown and Bridge Preparation

Top Row (Left to Right)

Gingival retraction cord, dental floss, burs in bur block

Bottom Row (Left to Right)

Mouth mirror, explorer, cotton forceps (pliers), spoon excavator, curette, gingival retraction cord instrument, Woodson, crown and bridge scissors, flexible cement mixing spatula, articulating paper holder and articulating paper, provisional crown-removing forceps, anesthetic aspirating syringe, air/water syringe tip, high-volume evacuation (HVE) tip

Sterilization Notes

Refer to each picture for correct procedure for instrument sterilization or disposal of material. Refer to other chapters for additional instruments on this tray setup that are not included in this chapter.



Tray Setup

Crown and Bridge Cementation

Top Row (Left to Right)

Burs in bur block

Bottom Row (Left to Right)

Mouth mirror, explorer, cotton forceps (pliers), spoon excavator, curette, Woodson, flexible cement mixing spatula, wooden bite stick, articulating paper holder and articulating paper, cotton rolls, provisional crown-removing forceps, dental floss (under provisional crown-removing forceps), trial crown remover (maxillary), air/water syringe tip, high-volume evacuation (HVE) tip

Sterilization Notes

Refer to each picture for correct procedure for instrument sterilization or disposal of material. Refer to other chapters for additional instruments on this tray setup that are not included in this chapter.

Endodontic Instruments



Instrument

Vitalometer/Pulp Tester

Function

To test vitality of pulp in teeth

Characteristics

Two types— Electronic and digital (digital readout)
Electric or battery operated

Practice Notes

The tester sends an impulse of electric current to the pulp, causing a reaction.
The current is increased by small increments until the patient indicates feeling a sensation.
Toothpaste is applied to the tip of the electrode to conduct electricity.
The tip is placed on the surface part (facial or lingual) of a natural tooth.
Each root and pulp on the tooth is tested.
Vitalometer is used exclusively with endodontic tray setups.

Sterilization Notes

Vitalometer tip must be precleaned, either, placed in a sterilizing pouch with an internal process indicator, sealed, then sterilized OR wrapped with an internal process indicator inside and secured on the outside with process indicator tape, then sterilized. Verify appropriate color change has been achieved in external process indicator immediately after removal from sterilizer then check internal process indicator before treatment. Refer to state regulations for any additional state requirements. Barriers should be used on the unit or the manufacturer's recommendation for disinfection of unit should be followed.





Instrument

Endodontic Long-Shank Spoon Excavator

Function

To reach deep into the canal to remove coronal pulp tissue, decay, and temporary cements

Characteristics

Long shank to reach deep into cavity preparation
Double ended
Range of sizes available

Practice Notes

Endodontic Long-Shank Spoon is used exclusively on endodontic tray setups.

Sterilization Notes

Endodontic Long-Shank Spoon Excavator must be precleaned, either, placed in a sterilizing pouch with an internal process indicator, sealed, then sterilized OR wrapped with an internal process indicator inside and secured on the outside with process indicator tape, then sterilized. Verify appropriate color change has been achieved in external process indicator immediately after removal from sterilizer then check internal process indicator before treatment. Refer to state regulations for any additional state requirements.



Instrument

Endodontic Explorer

Function

To locate opening of small canal orifices for endodontic procedure

Characteristics

Double ended

Working end—Longer than regular explorer to reach opening of canals

Practice Note

Endodontic Explorer is used exclusively on endodontic tray setups.

Sterilization Notes

Endodontic Explorer must be precleaned, either, placed in a sterilizing pouch with an internal process indicator, sealed, then sterilized OR wrapped with an internal process indicator inside and secured on the outside with process indicator tape, then sterilized. Verify appropriate color change has been achieved in external process indicator immediately after removal from sterilizer then check internal process indicator before treatment. Refer to state regulations for any additional state requirements.





Instrument

Endodontic Locking Forceps (Pliers)

Function

To grasp and lock material for transfer into and out of oral cavity

Characteristic

Similar to regular cotton forceps except for locking mechanism to secure material on the working end of the forceps (pliers)

Practice Note

Endodontic Locking Forceps are used on endodontic tray setup and could also be used on restorative tray setups.

Sterilization Notes

Endodontic Locking Forceps must be precleaned open and unlocked, placed in an open and unlocked position either in a sterilizing pouch with an internal process indicator, sealed, then sterilized OR wrapped with an internal process indicator inside and secured on the outside with process indicator tape, then sterilized. Verify appropriate color change has been achieved in external process indicator immediately after removal from sterilizer then check internal process indicator before treatment. Refer to state regulations for any additional state requirements.

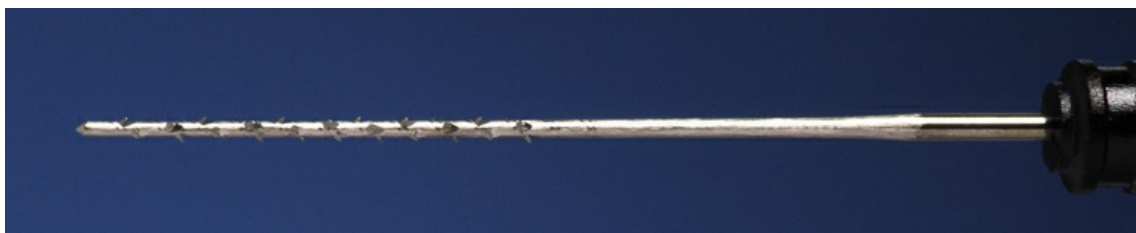

Instrument

Broach

Function

To remove pulp tissue from canal(s)

Characteristics

Working end—Barbed wire protrusions on shaft grab and remove vital or nonvital pulp fibers

Handles—Color coded according to size

Range of sizes—Diameter increases with size.

Practice Notes

Endodontic Broach is used exclusively on endodontic tray setups.

Sterilization Notes

Endodontic Broach must be disposed of in a sharps container. For single use only.

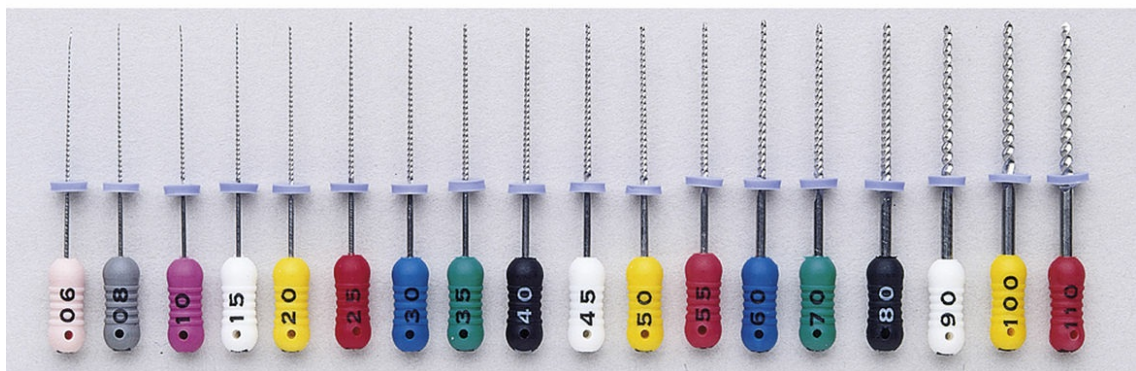

Instrument

Endodontic File—K Type

Functions

To clean inside walls of canal
To contour inner walls of canal

Characteristics

Twisted design—More twists per millimeter than reamer
Used with push-pull motion
Handles—Color coded according to size
Range of sizes—To accommodate width of canal; diameter increases with size.
Available in different lengths

Examples

21 mm, 25 mm, 31 mm

Practice Note

Endodontic File—K type is used exclusively on endodontic tray setups.

Sterilization Notes

Endodontic File—K Type must be precleaned, either, placed in a sterilizing pouch with an internal process indicator, sealed, then sterilized OR wrapped with an internal process indicator inside and secured on the outside with process indicator tape, then sterilized. Verify appropriate color change has been achieved in external process indicator immediately after removal from sterilizer then check internal process indicator before treatment. Refer to state regulations for any additional state requirements. OR used File must be disposed of in a sharps container. Rubber stopper on the file should be disposed of in the garbage.



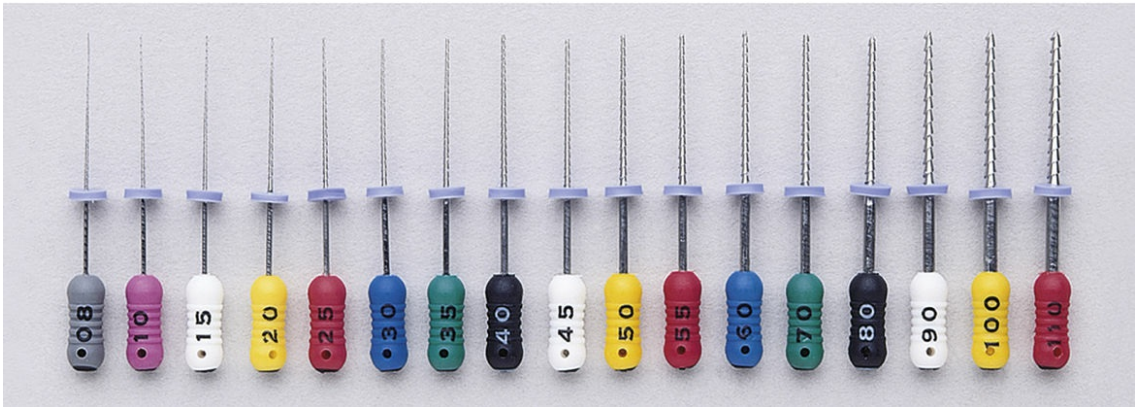

Instrument

Endodontic File—Hedstrom

Functions

To clean inside walls of canal
To enlarge and smooth inner walls of canal

Characteristics

Triangular cutting edge
Handles—Color coded according to size
Range of sizes—To accommodate width of canal; diameter increases with size.
Available in different lengths

Examples

21 mm, 25 mm, 31 mm

Practice Note

Endodontic File—Hedstrom is used exclusively on endodontic tray setups.

Sterilization Notes

Endodontic File—Hedstrom must be precleaned, either, placed in a sterilizing pouch with an internal process indicator, sealed, then sterilized OR wrapped with an internal process indicator inside and secured on the outside with process indicator tape, then sterilized. Verify appropriate color change has been achieved in external process indicator immediately after removal from sterilizer then check internal process indicator before treatment. Refer to state regulations for any additional state requirements. OR used File must be disposed of in a sharps container. Rubber stopper on the file should be disposed of in the garbage.



Instrument

Reamer

Functions

To cut and smooth dentinal walls of canal

To enlarge inner walls of canal

Characteristics

Twisted triangular cutting edge (similar to K-type file, but cutting edge is farther apart and has fewer twists per millimeter)

Used with twisting motion

Handles—Color coded according to size

Range of sizes—To accommodate width of canal; diameter increases with size.

Available in different lengths

Examples

21 mm, 25 mm, 31 mm

Practice Note

Reamer is used exclusively on endodontic tray setups.

Sterilization Notes

Reamer must be precleaned, either, placed in a sterilizing pouch with an internal process indicator, sealed, then sterilized OR wrapped with an internal process indicator inside and secured on the outside with process indicator tape, then sterilized. Verify appropriate color change has been achieved in external process indicator immediately after removal from sterilizer then check internal process indicator before treatment. Refer to state regulations for any additional state requirements. Or used Reamer must be disposed of in a sharps container. Rubber stopper on the file should be disposed of in the garbage.

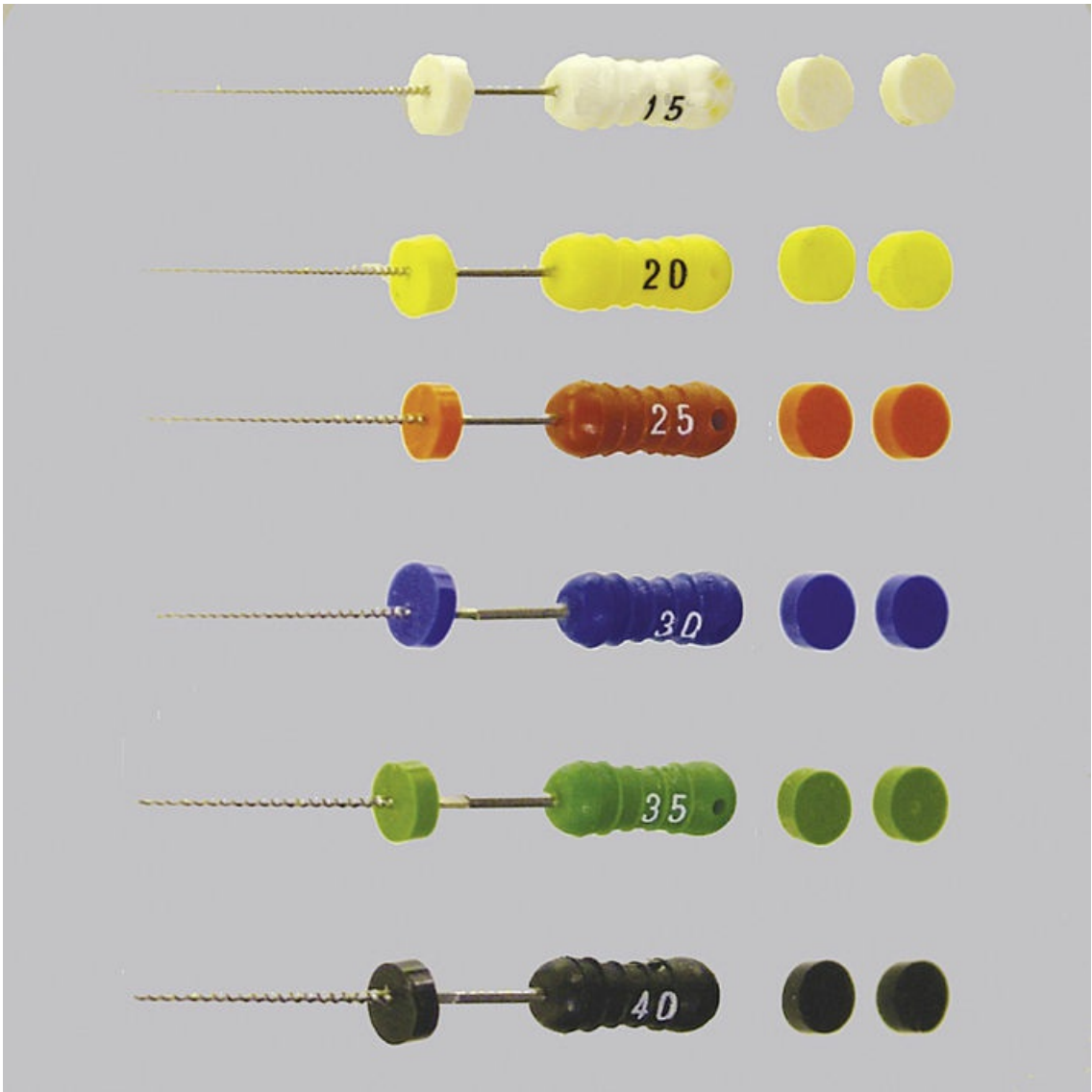

Instrument

Endodontic Stoppers

Function

To place onto an intracanal instrument such as a file or reamer to help determine length of canal

Characteristics

Files or reamers are measured from stopper to apex of root to determine length of canal.

(Radiographs also help determine length.)

Stoppers are made from rubber, silicone, or plastic.

Practice Notes

Endodontic Stoppers are color coded to correspond to a particular file or reamer, or a single color of stopper is used for all files or reamers.

Endodontic Stoppers are used exclusively on endodontic tray setups.

Sterilization Notes

Endodontic Stoppers should be disposed of in the garbage. Single use only.

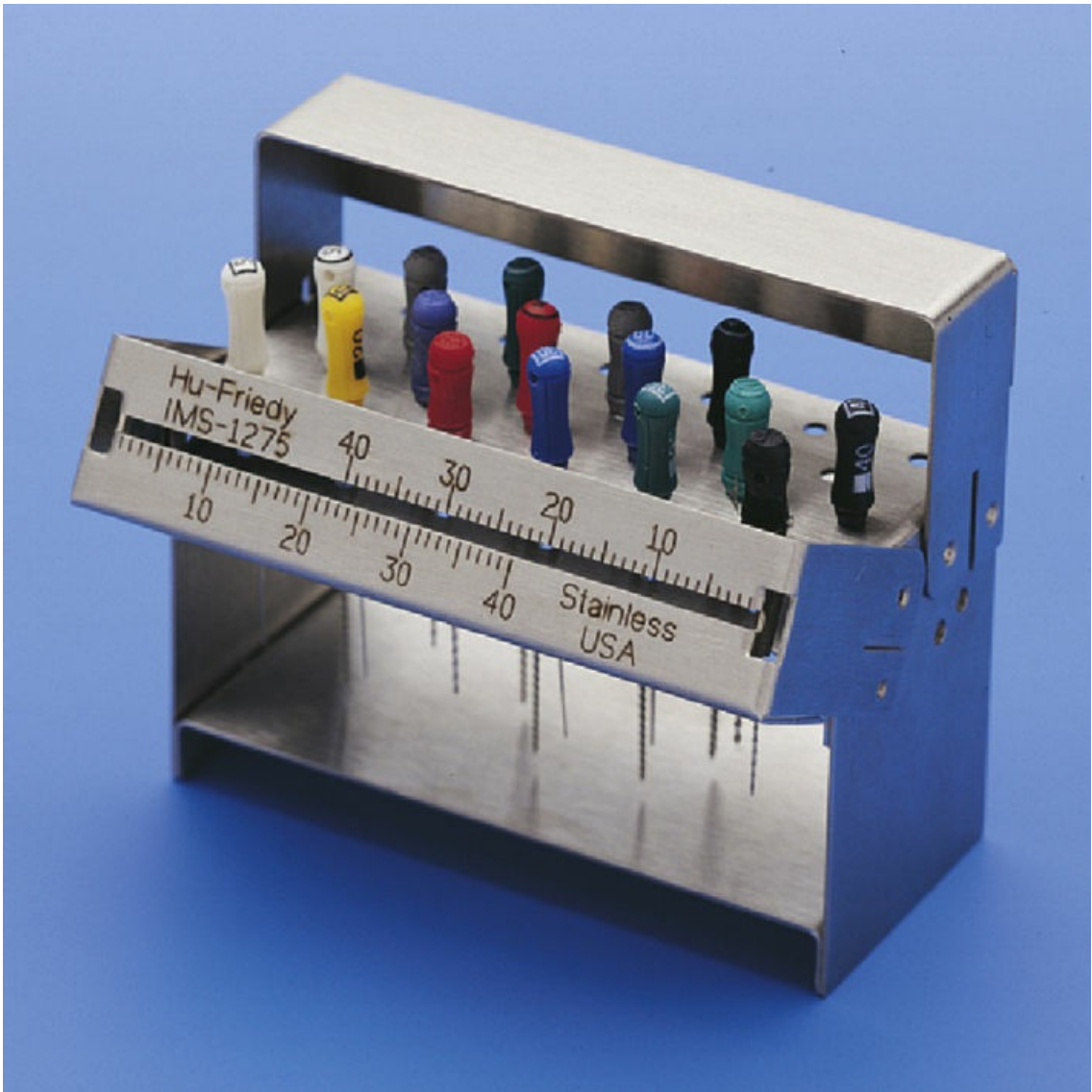

Instrument

Endodontic Stand

Functions

To hold endodontic files and reamers

To measure endodontic files and reamers with millimeter ruler etched in container; may be measured from right or left side of stand

Characteristic

Container closes with endodontic files and reamers for sterilization processes.

Practice Note

Endodontic Stand is used exclusively with endodontic tray setups.

Sterilization Notes

File or reamer in Endodontic Stand and endodontic stand must be precleaned, either, placed in a sterilizing pouch with an internal process indicator, sealed, then sterilized OR wrapped with an internal process indicator inside and secured on the outside with process indicator tape, then sterilized. Verify appropriate color change has been achieved in external process indicator immediately after removal from sterilizer then check internal process indicator before treatment. Refer to state regulations for any additional state requirements. Or used file or reamer must be disposed of in a sharps container. Rubber stopper on the file should be disposed of in the garbage. Single use only.



Instrument

Endodontic Millimeter Ruler

Function

To measure files, reamers, other instruments, and materials in millimeter increments

Characteristic

Variety of designs

Practice Notes

Endodontic Millimeter Ruler could be used in areas of dentistry other than on endodontic tray setups.

Sterilization Notes

Endodontic Millimeter Ruler must be precleaned, either, placed in a sterilizing pouch with an internal process indicator, sealed, then sterilized OR wrapped with an internal process indicator inside and secured on the outside with process indicator tape, then sterilized. Verify appropriate color change has been achieved in external process indicator immediately after removal from sterilizer then check internal process indicator before treatment. Refer to state regulations for any additional state requirements.





Instrument

Electronic Apex Locator

Function

To electronically measure length of canal to apex of tooth

Characteristics

Attaches to file or reamer and is placed in canal using dry or wet environment
Readout indicates length of canal—Tone or digital

Practice Note

Electronic Apex Locator is used exclusively with endodontic tray setups.

Sterilization Notes

Electronic Apex Locator device that enters patient's mouth must be precleaned, either, placed in a sterilizing pouch with an internal process indicator, sealed, then sterilized OR wrapped with an internal process indicator inside and secured on the outside with process indicator tape, then sterilized. Verify appropriate color change has been achieved in external process indicator immediately after removal from sterilizer then check internal process indicator before treatment. Refer to state regulations for any additional state requirements. Barriers should be used on the unit, or the manufacturer's recommendation for disinfection should be followed.

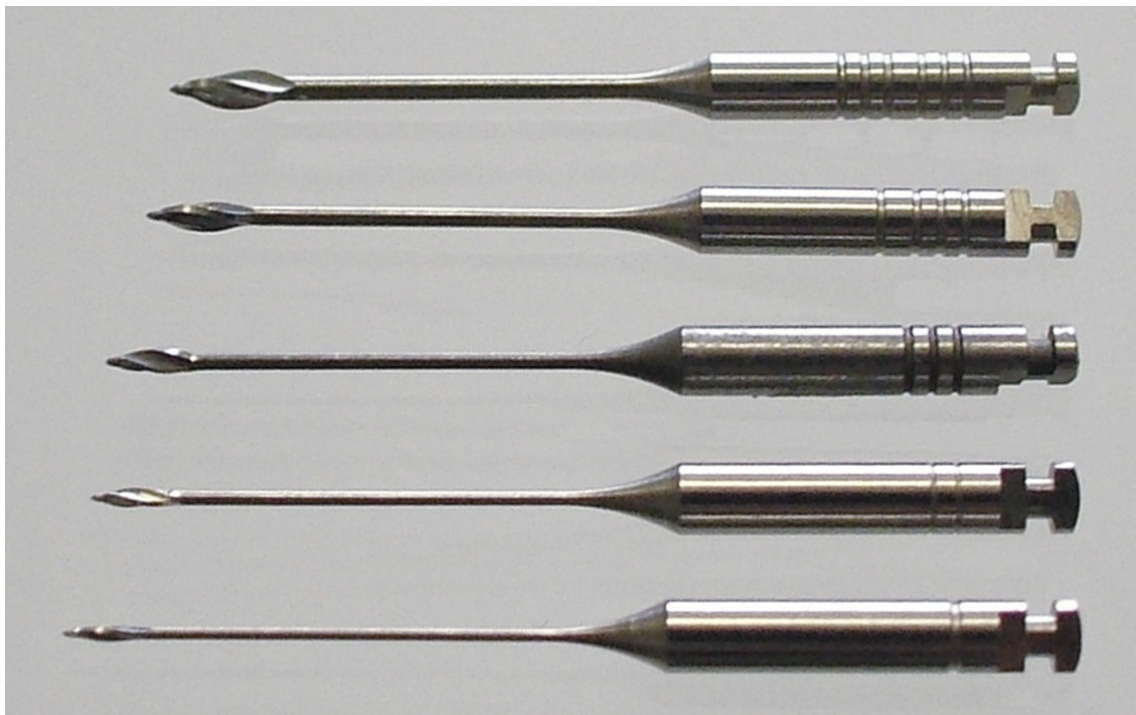

Instrument

Gates Glidden Bur or Drill

Functions

To enlarge walls of pulp chamber
To open canal orifice

Characteristics

Long-shank bur
Elliptical or flame-shaped cutting edge
Latch type—Used with slow-speed contra-angle handpiece (air driven or electric)
Range of sizes—Size identified by number of grooves on shank
Two lengths—Shorter for posterior teeth, longer for anterior teeth

Practice Note

Gates Glidden Burs are used exclusively on endodontic tray setups.

Sterilization Notes

Gates Glidden Bur or Drill must be precleaned, either, placed in a sterilizing pouch with an internal process indicator, sealed, then sterilized OR wrapped with an internal process indicator inside and secured on the outside with process indicator tape, then sterilized. Verify appropriate color change has been achieved in external process indicator immediately after removal from sterilizer then check internal process indicator before treatment. Refer to state regulations for any additional state requirements. Or used Gates Glidden Bur must be disposed of in a sharps container.



Instrument

Endodontic Irrigating Syringe

Function

To carry and dispense irrigating solution into canal for cleansing during débridement of canal

Characteristics

Disposable

Two sizes—3 mL (pictured) and 12 mL

Practice Note

Endodontic Irrigating Syringe could be used in areas of dentistry other than on endodontic tray setups.

Sterilization Notes

Endodontic Irrigating Syringe should be disposed of in a sharps container. For single use only.



Instrument

Sterile Absorbent Paper Points

Function

To dry pulp chambers of canal—New points inserted repeatedly until pulp chamber is completely dry

Characteristics

Size of point corresponds to width of canal
Range of sizes available

Practice Notes

The length of the paper point is measured to ensure that it corresponds to the length of the canal.
Paper points are used exclusively on endodontic tray setups.

Sterilization Notes

Sterile Absorbent Paper Points should be disposed of in the garbage. Single use only.





Instrument

Gutta-Percha

Function

To fill pulp chamber after completion of canal preparation (called obturation)

Characteristics

Solid at room temperature; becomes soft and pliable when heated
May be heated in a cartridge and then dispensed into canal
Range of sizes—To correspond to size of canal

Practice Notes

Endodontic sealer, a cement material, is used with gutta-percha for final sealing of the canal.
Gutta-Percha is used exclusively on an endodontic tray setup.

Sterilization Notes

Gutta-Percha should be disposed of in the garbage.

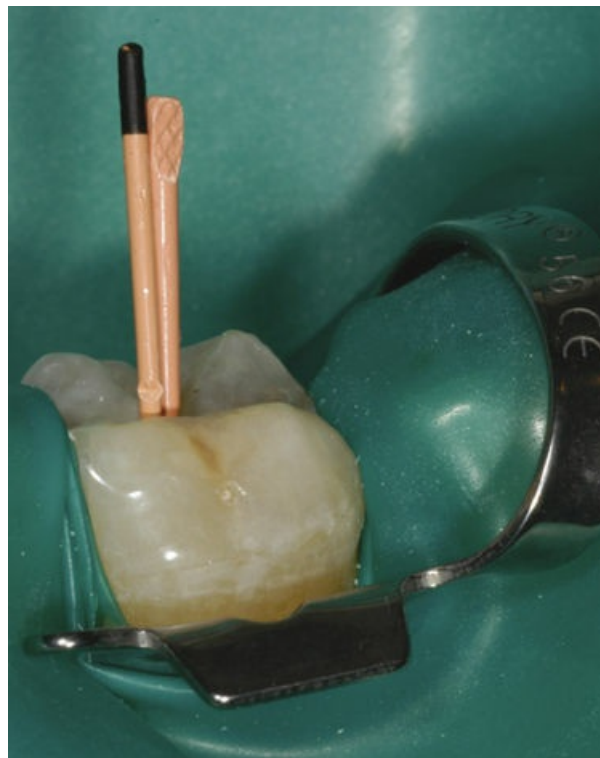

Instrument

Lentulo Spiral

Function

To place endodontic sealer or cement in canal for final seal before placement of gutta-percha

Characteristic

Latch-type shank—Used with slow-speed contra-angled handpiece (air driven or electric)

Practice Note

Lentulo Spiral is used exclusively on endodontic tray setups.

Sterilization Notes

Lentulo Spiral must be precleaned, either, placed in a sterilizing pouch with an internal process indicator, sealed, then sterilized OR wrapped with an internal process indicator inside and secured on the outside with process indicator tape, then sterilized. Verify appropriate color change has been achieved in external process indicator immediately after removal from sterilizer then check internal process indicator before treatment. Refer to state regulations for any additional state requirements. Or used lentulo spiral must be disposed of in a sharps container.





Instrument

Gutta-Percha Warming Unit

Functions

To heat gutta-percha outside the mouth before use

To inject heated gutta-percha in thermoplastic state into prepared canals

Characteristics

Gutta-percha pellets—Used to load unit

Delivery system—Needle attaches to gun delivering gutta-percha into canal

Practice Notes

Temperature of the gutta-percha in the unit can be adjusted to control the viscosity of the material.

Gutta-Percha warming unit is used exclusively with endodontic tray setups.

Sterilization Notes

Gutta-Percha Warming Unit needle attached to the gutta-percha warming unit gun must be precleaned, either, placed in a sterilizing pouch with an internal process indicator, sealed, then sterilized OR wrapped with an internal process indicator inside and secured on the outside with process indicator tape, then sterilized. Verify appropriate color change has been achieved in external process indicator immediately after removal from sterilizer then check internal process indicator before treatment. Refer to state regulations for any additional state requirements. Or needle must be disposed of in a sharps container. Gutta-percha warming unit must be disinfected according to the manufacturer's recommendation.

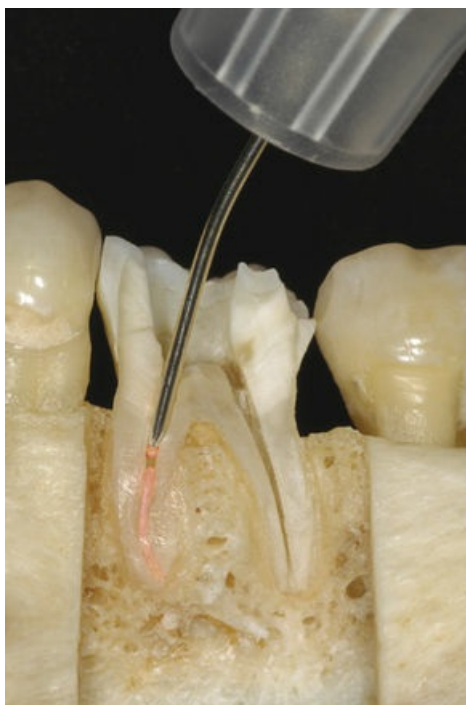



Instrument

Endodontic Spreader

Functions

To help condense gutta-percha laterally in canal
To use for final filling of canal

Characteristics

Pointed tip
Working end—Has rings in millimeter increments
Two handle styles—Conventional (pictured), finger spreader
Range of sizes—To correspond to size of canal

Practice Note

Endodontic Spreader is used exclusively on endodontic tray setups.

Sterilization Notes

Endodontic Spreader must be precleaned, either, placed in a sterilizing pouch with an internal process indicator, sealed, then sterilized OR wrapped with an internal process indicator inside and secured on the outside with process indicator tape, then sterilized. Verify appropriate color change has been achieved in external process indicator immediately after removal from sterilizer then check internal process indicator before treatment. Refer to state regulations for any additional state requirements.



Instrument

Endodontic Plugger

Functions

To help condense gutta-percha vertically in canal
To use for final filling of canal

Characteristics

Flat tip for condensing gutta-percha
Working end—Has rings in millimeter increments
Two handle styles—Conventional (pictured), finger spreader
Range of sizes—To correspond to size of canal

Practice Note

Endodontic Plugger is used exclusively on endodontic tray setups.

Sterilization Notes

Endodontic Plugger must be precleaned, either, placed in a sterilizing pouch with an internal process indicator, sealed, then sterilized OR wrapped with an internal process indicator inside and secured on the outside with process indicator tape, then sterilized. Verify appropriate color change has been achieved in external process indicator immediately after removal from sterilizer then check internal process indicator before treatment. Refer to state regulations for any additional state requirements.





Instrument

Glick Instrument

Functions

To condense gutta-percha into endodontically prepared teeth, using plugger end
To sever excess gutta-percha after plugger end is heated
To carry and place material into tooth, using paddle end

Characteristics

Double ended:

- Plugger end— May have rings in millimeter increments
- Paddle end

Practice Note

Glick Instrument is used exclusively on endodontic tray setups.

Sterilization Notes

Glick Instrument must be precleaned, either, placed in a sterilizing pouch with an internal process indicator, sealed, then sterilized OR wrapped with an internal process indicator inside and secured on the outside with process indicator tape, then sterilized. Verify appropriate color change has been achieved in external process indicator immediately after removal from sterilizer then check internal process indicator before treatment. Refer to state regulations for any additional state requirements.

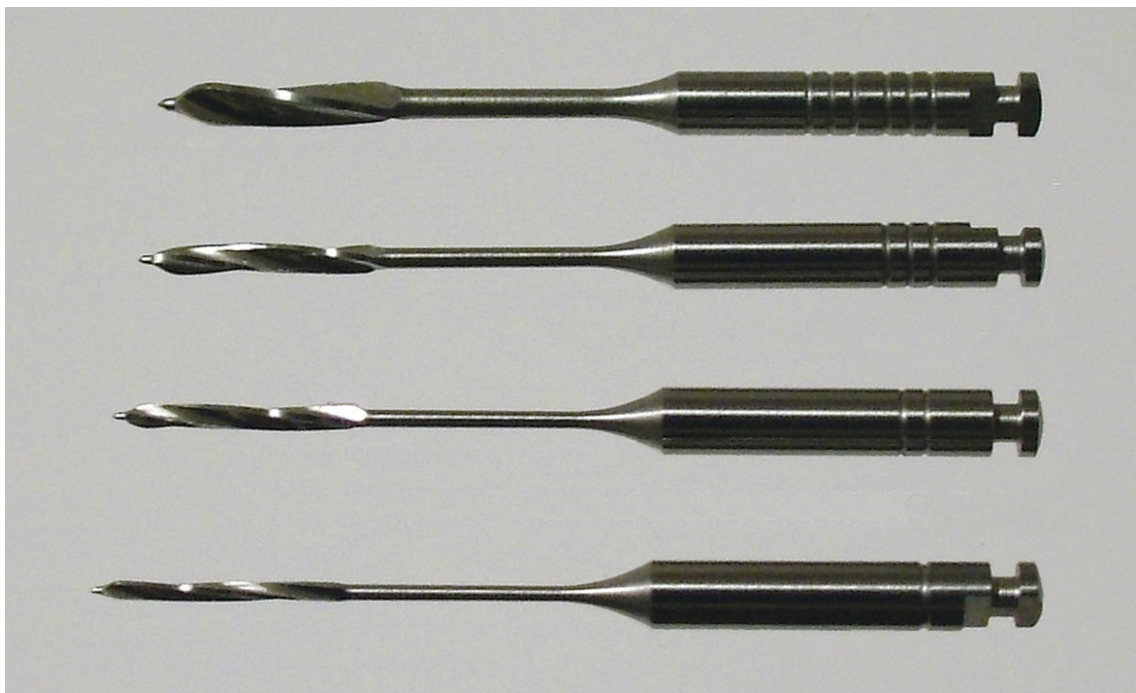

Instrument

Peso File

Functions

To prepare canal for endodontic post

To remove portion of gutta-percha sealed in canal to make room for endodontic post

Characteristics

Parallel cutting edges

Latch-type shank—Used with slow-speed contra-angle handpiece (air driven or electric)

Range of sizes—Size identified by number of grooves on shank

Practice Note

Peso File is used exclusively on endodontic tray setups.

Sterilization Notes

Peso File must be precleaned, either, placed in a sterilizing pouch with an internal process indicator, sealed, then sterilized OR wrapped with an internal process indicator inside and secured on the outside with process indicator tape, then sterilized. Verify appropriate color change has been achieved in external process indicator immediately after removal from sterilizer then check internal process indicator before treatment. Refer to state regulations for any additional state requirements. Or used peso file must be disposed of in a sharps container.

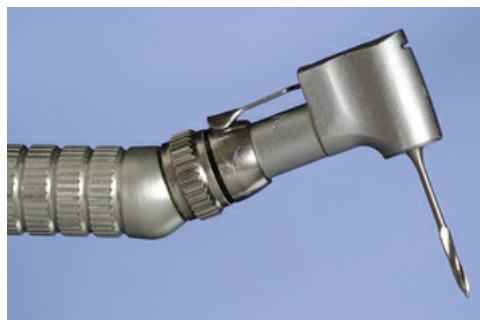

Instrument

Micro Retro Amalgam Carrier

Function

To carry amalgam to surgical site of apicoectomy

Characteristics

Very small—To accommodate retro fills for apicoectomy
Surgical apicoectomy procedure is performed, if needed, after an endodontic procedure is completed.

Practice Note

Micro Retro Amalgam Carrier is used with a surgical tray setup for an apicoectomy.

Sterilization Notes

Micro Retro Amalgam Carrier must be precleaned, either, placed in a sterilizing pouch with an internal process indicator, sealed, then sterilized OR wrapped with an internal process indicator inside and secured on the outside with process indicator tape, then sterilized. Verify appropriate color change has been achieved in external process indicator immediately after removal from sterilizer then check internal process indicator before treatment. Refer to state regulations for any additional state requirements.



Instrument

Micro Retro Mouth Mirror

Function

To view surgical site of apicoectomy retro fill

Characteristics

Very small—To accommodate retro fills for apicoectomy
Smaller sizes available

Practice Note

Micro Retro Mouth Mirror is used with a surgical tray setup for an apicoectomy.

Sterilization Notes

Micro Retro Mouth Mirror must be precleaned, either, placed in a sterilizing pouch with an internal process indicator, sealed, then sterilized OR wrapped with an internal process indicator inside and secured on the outside with process indicator tape, then sterilized. Verify appropriate color change has been achieved in external process indicator immediately after removal from sterilizer then check internal process indicator before treatment. Refer to state regulations for any additional state requirements.



Tray Setup

Opening a Tooth for Endodontic Therapy

Top Row (Left to Right)

Millimeter ruler with finger ring; coarse, medium, and fine absorbent sterile paper points; burs in bur block

Bottom Row (Left to Right)

Mouth mirror, endodontic explorer, endodontic locking forceps, endodontic long-shank spoon excavator, Glick instrument, Woodson, endodontic locking forceps (extra), irrigating disposable syringe, scissors, broaches, endodontic K-type file with color-coded rubber stops, anesthetic aspirating syringe, air/water syringe tip, high-volume evacuation (HVE) tip

Sterilization Notes

Refer to each picture for correct procedure for instrument sterilization or disposal of instrument or material. Refer to other chapters for additional instruments on this tray setup that are not included in this chapter.



Tray Setup

Sealing a Tooth for Endodontic Therapy

Top Row (Left to Right)

Millimeter ruler with finger ring; gutta-percha in vials—assorted sizes; coarse, medium, fine absorbent sterile paper points; burs in bur block

Bottom Row (Left to Right)

Mouth mirror, endodontic explorer, endodontic locking forceps, endodontic long-shank spoon excavator, endodontic spreader, endodontic plugger, Glick instrument, Woodson, endodontic locking cotton forceps (extra), irrigating disposable syringe, scissors, endodontic K-type file with color-coded rubber stops, anesthetic aspirating syringe, air/water syringe tip, high-volume evacuation (HVE) tip

Sterilization Notes

Refer to each picture for correct procedure for instrument sterilization or disposal of instrument or material. Refer to other chapters for additional instruments on this tray setup that are not included in this chapter.

Hygiene Instruments

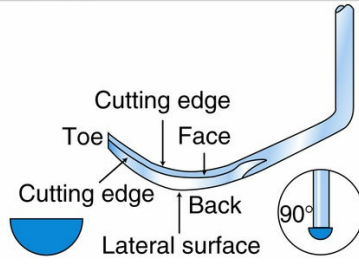
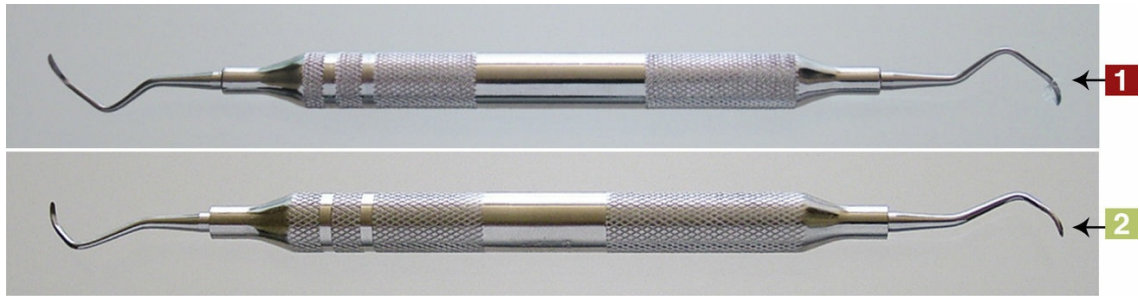

Instrument

Universal Curettes (Curets)

Functions

To remove deposits and stains from teeth

To remove soft tissue lining of periodontal pocket and root planing

Characteristics

Blade—Two cutting edges, rounded toe, rounded back; at 90-degree angle to lower shank

Flexible or rigid shank; length varies to accommodate clinical crown of tooth

Single or double ended

Range of sizes

Curette named by designer:

- Barnhart ½
- Ratcliff ⅜

Practice Note

Universal Curettes are used on hygiene, periodontal, and operative tray setups.

Sterilization Notes

Universal Curettes must be precleaned, either, placed in a sterilizing pouch with an internal process indicator, sealed, then sterilized OR wrapped with an internal process indicator inside and secured on the outside with process indicator tape, then sterilized. Verify appropriate color change has been achieved in external process indicator immediately after removal from sterilizer then check internal process indicator before treatment. Refer to state regulations for any additional state requirements.

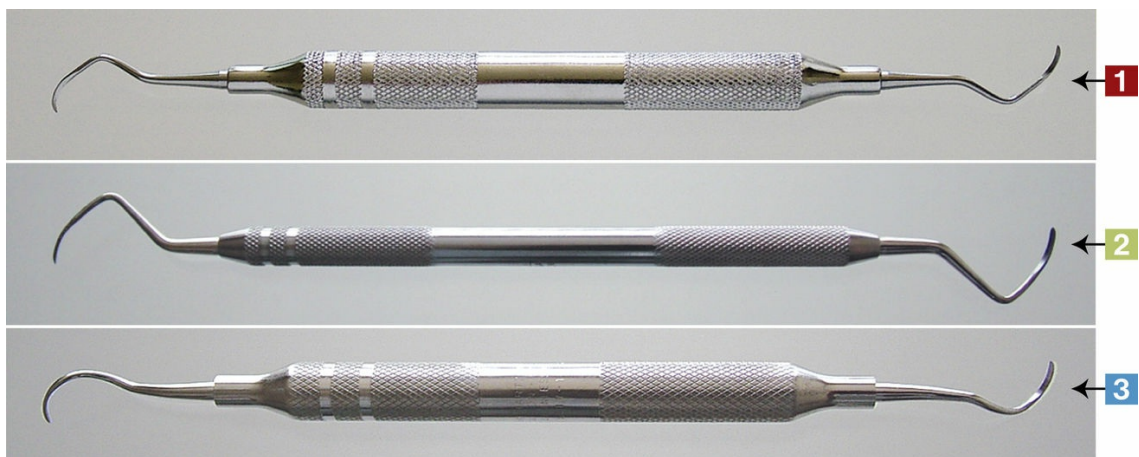

Instrument

Universal Curettes (Curet)

Functions

- To scale supragingival and subgingival surfaces
- To remove deposits and stains from teeth
- To remove soft tissue lining of periodontal pocket and root planing

Characteristics

- Blade—Two cutting edges, rounded toe, rounded back; at 90-degree angle to lower shank
- Flexible or rigid shank; length varies to accommodate clinical crown of tooth
- Single or double ended
- Range of sizes
- Curette named by designer:

- UC/Rule $\frac{5}{8}$
- Loma Linda $\frac{11}{12}$
- McCall $\frac{17}{18}$

Practice Note

Universal Curettes are used on hygiene, periodontal, and operative tray setups.

Sterilization Notes

Universal Curettes must be precleaned, either, placed in a sterilizing pouch with an internal process indicator, sealed, then sterilized OR wrapped with an internal process indicator inside and secured on the outside with process indicator tape, then sterilized. Verify appropriate color change has been achieved in external process indicator immediately after removal from sterilizer then check internal process indicator before treatment. Refer to state regulations for any additional state requirements.



Instrument

Langer Universal Curettes

Functions

- To scale supragingival and subgingival surfaces
- To remove deposits and stains from teeth
- To remove soft tissue lining of periodontal pocket and root planing

Characteristics

- Blade—Two cutting edges, with face at 90-degree angle to lower shank
- Design function with three bends in the shank, improving posterior access
- Langer universal curettes designed with the shank design of a Gracey combined with a universal blade
- Single or double ended
- Range of sizes

Practice Note

Langer Universal Curettes are used on hygiene and periodontal tray setups.

Sterilization Notes

Langer Universal Curettes must be precleaned, either, placed in a sterilizing pouch with an internal process indicator, sealed, then sterilized OR wrapped with an internal process indicator inside and secured on the outside with process indicator tape, then sterilized. Verify appropriate color change has been achieved in external process indicator immediately after removal from sterilizer then check internal process indicator before treatment. Refer to state regulations for any additional state requirements.

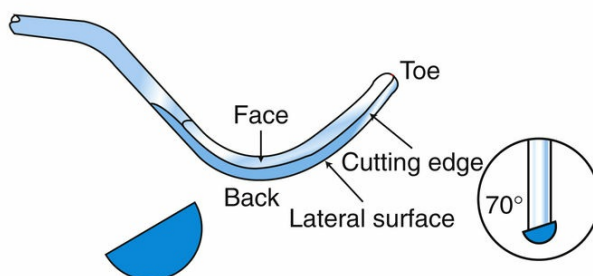
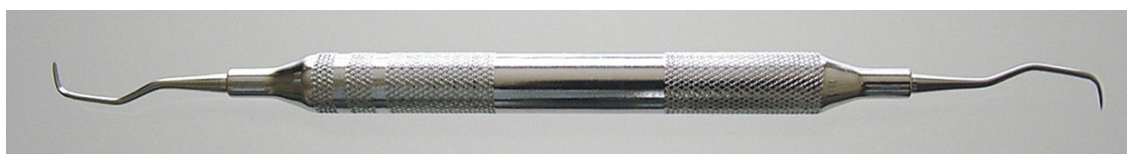

Instrument

Area-Specific Curettes—Anterior

Functions

To scale and remove deposits from subgingival surfaces of anterior teeth
To use for root planing, periodontal débridement, and soft tissue curettage

Characteristics

Two cutting edges (only lower cutting edge used)
Blade—Rounded back and toe; at 70-degree angle to lower shank; types: standard, rigid, extra rigid
Curvature of blade designed to adapt to specific teeth and surfaces
Range of sizes available: $\frac{1}{2}$, $\frac{3}{4}$, $\frac{5}{6}$
Curette named by designer: Gracey, Kramer-Nevins, Turgeon

Practice Note

Area-specific Curettes—Anterior are used on hygiene and periodontal tray setups.

Sterilization Notes

Area-Specific Curettes must be precleaned, either, placed in a sterilizing pouch with an internal process indicator, sealed, then sterilized OR wrapped with an internal process indicator inside and secured on the outside with process indicator tape, then sterilized. Verify appropriate color change has been achieved in external process indicator immediately after removal from sterilizer then check internal process indicator before treatment. Refer to state regulations for any additional state requirements.



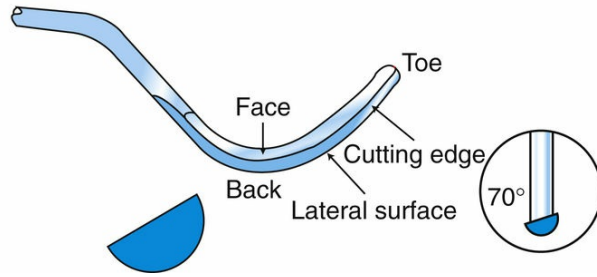

Instrument

Area-Specific Curettes—Posterior

Functions

To scale and remove deposits from subgingival surfaces of posterior teeth
To use for root planing, periodontal debridement, and soft tissue curettage

Characteristics

Two cutting edges (only lower cutting edge used)
Blade—Rounded back and toe; at 70-degree angle to lower shank; types: standard, rigid, extra rigid
Curvature of blade designed to adapt to specific teeth and surfaces
Range of size, shape, and bends in shank
Two bends in shank

Examples

$7/8$, $9/10$
Three bends in shank

Examples

$11/12$, $13/14$, $15/16$, $17/18$
Curette named by designer: Gracey, Kramer-Nevins, Turgeon

Practice Note

Area-specific Curettes—Posterior are used on hygiene and periodontal tray setups.

Sterilization Notes

Area-specific Curettes must be precleaned, either, placed in a sterilizing pouch with an internal process indicator, sealed, then sterilized OR wrapped with an internal process indicator inside and secured on the outside with process indicator tape, then sterilized. Verify appropriate color change has been achieved in external process indicator immediately after removal from sterilizer then check internal process indicator before treatment. Refer to state regulations for any additional state requirements.



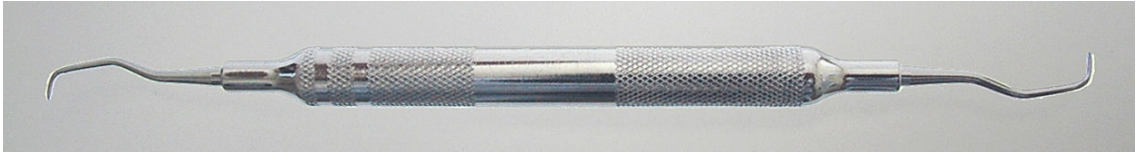

Instrument

Extended Area-Specific Curettes—Anterior

Function

To scale and remove deposits in deep periodontal pockets 5 mm or deeper

Characteristics

Two cutting edges (only lower cutting edge used)
Blade at 70-degree angle to lower shank; types: standard, rigid, extra rigid
Curvature of blade designed to adapt to anteriors
Terminal shank redesigned—3 mm longer than standard area-specific curette
Manufacturer's trademark name usually follows $\frac{1}{2}$, $\frac{3}{4}$, $\frac{5}{8}$ numbering system
Range of sizes—Commonly used types: $\frac{3}{4}$, $\frac{5}{8}$
Double-ended curettes packaged in sets
Curettes named by designer: Gracey $\frac{1}{2}$

Practice Note

Extended Area-Specific Curettes—Anterior are used on hygiene and periodontal tray setups.

Sterilization Notes

Extended Area-Specific Curettes must be precleaned, either, placed in a sterilizing pouch with an internal process indicator, sealed, then sterilized OR wrapped with an internal process indicator inside and secured on the outside with process indicator tape, then sterilized. Verify appropriate color change has been achieved in external process indicator immediately after removal from sterilizer then check internal process indicator before treatment. Refer to state regulations for any additional state requirements.

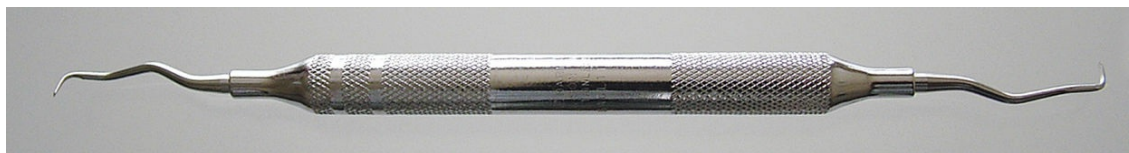

Instrument

Extended Area-Specific Curettes—Posterior

Function

To scale and remove deposits in deep periodontal pockets (5 mm or deeper)

Characteristics

Two cutting edges (only lower cutting edge used)

Blade at 70-degree angle to lower shank; types: standard, rigid, extra rigid

Curvature of blade designed to adapt to premolars, molars

Terminal shank redesigned—3 mm longer than standard area-specific curette

Range of sizes

Commonly used types: $11/12$, $13/14$, $15/16$, $17/18$

Double-ended curettes packaged in sets

Curettes named by designer: Gracey $11/12$ rigid, Gracey $11/12$

Practice Note

Extended Area-Specific Curettes—Posterior are used on hygiene and periodontal tray setups.

Sterilization Notes

Extended Area-Specific Curettes must be precleaned, either, placed in a sterilizing pouch with an internal process indicator, sealed, then sterilized OR wrapped with an internal process indicator inside and secured on the outside with process indicator tape, then sterilized. Verify appropriate color change has been achieved in external process indicator immediately after removal from sterilizer then check internal process indicator before treatment. Refer to state regulations for any additional state requirements.



Instrument

Mini Extended Area-Specific Curettes—Anterior

Function

To scale in deep periodontal pockets (5 mm)

Characteristics

Blade redesigned to be half the length of extended area-specific curette

Designed for narrow roots, pockets, or furcations

Two cutting edges (only lower cutting edge used)

Blade at 70-degree angle to lower shank; types: standard, rigid, extra rigid

Curvature of blade designed to adapt to anteriors

Range of sizes

Manufacturer's trademark name usually follows $\frac{1}{2}$, $\frac{3}{4}$, $\frac{5}{8}$ numbering system

Curettes named by designer: Gracey $\frac{1}{2}$

Practice Note

Mini Extended Area-Specific Curettes—Anterior are used on hygiene and periodontal tray setups.

Sterilization Notes

Mini Extended Area-Specific Curettes must be precleaned, either, placed in a sterilizing pouch with an internal process indicator, sealed, then sterilized OR wrapped with an internal process indicator inside and secured on the outside with process indicator tape, then sterilized. Verify appropriate color change has been achieved in external process indicator immediately after removal from sterilizer then check internal process indicator before treatment. Refer to state regulations for any additional state requirements.

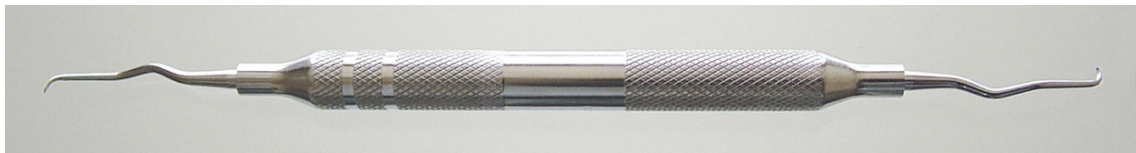

Instrument

Mini Extended Area-Specific Curettes—Posterior

Function

To scale in deep periodontal pockets (5 mm)

Characteristics

Blade redesigned to be half the length of extended area-specific curette
Designed for narrow roots, pockets, or furcations
Two cutting edges (only lower cutting edge used)
Blade at 70-degree angle to lower shank; types: standard, rigid, extra rigid
Curvature of blade designed to adapt to premolars, molars
Range of size, shape, and bends in shank available
Two bends in shank

Examples

$\frac{7}{8}$, $\frac{9}{10}$

Three bends in shank

Examples

$\frac{11}{12}$, $\frac{13}{14}$, $\frac{15}{16}$, $\frac{17}{18}$

Curettes named by designer: Gracey $\frac{11}{12}$ mini extender

Practice Note

Mini Extended Area-Specific Curettes—Posterior are used on hygiene and periodontal tray setups.

Sterilization Notes

Mini Extended Area-Specific Curettes must be precleaned, either, placed in a sterilizing pouch with an internal process indicator, sealed, then sterilized OR wrapped with an internal process indicator inside and secured on the outside with process indicator tape, then sterilized. Verify appropriate color change has been achieved in external process indicator immediately after removal from sterilizer then check internal process indicator before treatment. Refer to state regulations for any additional state requirements.



Instrument

Implant Scaler

Function

To remove deposits and stains from surface of implant

Characteristics

- Disposable tips (each tip should be sterilized before use). Instrument with disposable tip attached.
- Titanium-coated scaler

Different designs allow scaling without scratching of titanium implants

Some tips are made of Plasteel—a high-grade resin

Practice Note

Implant Scalers are used on hygiene and periodontal tray setups.

Sterilization Notes

Handle and titanium-coated Scaler must be precleaned, either, placed in a sterilizing pouch with an internal process indicator, sealed, then sterilized OR wrapped with an internal process indicator inside and secured on the outside with process indicator tape, then sterilized. Verify appropriate color change has been achieved in external process indicator immediately after removal from sterilizer then check internal process indicator before treatment. Refer to state regulations for any additional state requirements. Or disposable scaler tip should be disposed of in a sharps container.



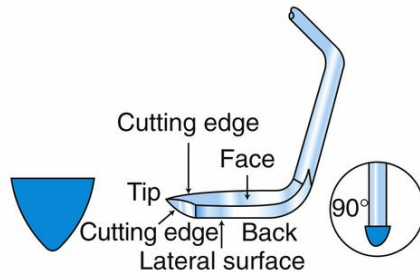
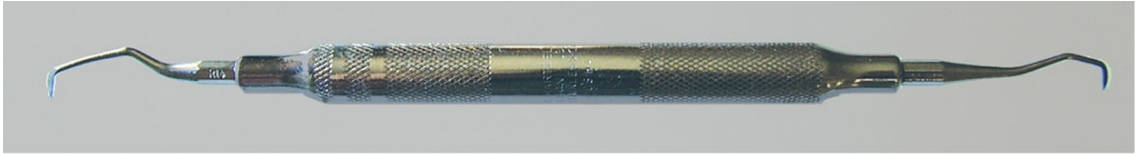

Instrument

Straight Sickle Scaler

Function

To remove large amounts of deposits from supragingival surfaces

Characteristics

Two cutting edges on straight blade that ends in sharp point

Long; two bends in shank

Variety of sizes and angles

Single or double ended—Two ends may be shaped differently

Practice Note

Straight Sickle Scaler is used on hygiene and periodontal tray setups.

Sterilization Notes

Straight Sickle Scaler must be precleaned, either, placed in a sterilizing pouch with an internal process indicator, sealed, then sterilized OR wrapped with an internal process indicator inside and secured on the outside with process indicator tape, then sterilized. Verify appropriate color change has been achieved in external process indicator immediately after removal from sterilizer then check internal process indicator before treatment. Refer to state regulations for any additional state requirements. Refer to state regulations for any additional state requirements.

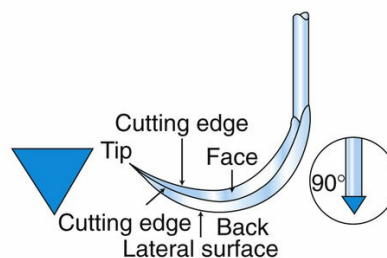

Instrument

Curved Sickle Scaler

Function

To remove large amounts of deposits from supragingival surfaces

Characteristics

Two cutting edges on curved blade that ends in sharp point

Long, straight shank with one gentle bend

Variety of sizes and angles

Single or double ended—Two ends may be shaped differently

- Montana Jack—Sharper, thinner blades with solid resin handle for comfortable grip.
- Traditional Curved Sickle Scaler

Practice Note

Curved Sickle Scaler is used on hygiene and periodontal tray setups.

Sterilization Notes

Curved Sickle Scaler must be precleaned, either, placed in a sterilizing pouch with an internal process indicator, sealed, then sterilized OR wrapped with an internal process indicator inside and secured on the outside with process indicator tape, then sterilized. Verify appropriate color change has been achieved in external process indicator immediately after removal from sterilizer then check internal process indicator before treatment. Refer to state regulations for any additional state requirements.



Instrument

Micro Mini-Five Area-Specific Curette

Function

To scale into periodontal pockets and root surfaces of 5 mm or more

Characteristics

Blade half the length of After Five or standard Gracey curettes

Shank slightly increased rigidity compared with traditional mini five Gracey curettes

Practice Notes

Designed for narrow pockets and furcations

Micro Mini-Five Area-Specific Curette—used on hygiene and periodontal tray setups

Sterilization Notes

Micro Mini-Five Area-Specific Curette must be precleaned, either, placed in a sterilizing pouch with an internal process indicator, sealed, then sterilized OR wrapped with an internal process indicator inside and secured on the outside with process indicator tape, then sterilized. Verify appropriate color change has been achieved in external process indicator immediately after removal from sterilizer then check internal process indicator before treatment. Refer to state regulations for any additional state requirements.



Instrument

Magnetostrictive Power Scaler

Function

To use with water-cooled ultrasonic inserts vibrating at high frequency

Characteristics

Ultra-high frequency sound waves convert mechanical energy into vibrations (frequency ranges from 18 to 50 kHz).

Some units (depending on manufacturer) have self-contained water reservoirs.

Some units (depending on manufacturer) have an additional air/water/sodium bicarbonate slurry polishing system to remove extrinsic stains and dental plaque.

A variety of sizes and designs are available.

Practice Note

Magnetostrictive Power Scaler/ Ultrasonic Scaling Unit is used during a routine prophylaxis appointment or for other appointments for root planing.

Sterilization Notes

Barriers should be used for Power Scaler unit. Refer to the manufacturer's recommendation for disinfecting the unit. Power scaler inserts must be precleaned, either, placed in a sterilizing pouch with an internal process indicator, sealed, then sterilized OR wrapped with an internal process indicator inside and secured on the outside with process indicator tape, then sterilized. Verify appropriate color change has been achieved in external process indicator immediately after removal from sterilizer then check internal process indicator before treatment. Refer to state regulations for any additional state requirements.



Instrument

Ultrasonic Scaler Instrument Tip—Supragingival

Functions

- To remove supragingival calculus from teeth
- To remove bacterial plaque from periodontal pockets
- To remove heavy debris and stains from teeth
- To remove excess cement from orthodontic bands after cementation and after band removal

Characteristics

- Supragingival Tip is inserted into the tubing on the ultrasonic scaling unit
- Available in different lengths (called stacks): 25 kHz or 30 kHz, depending on unit
- Water-cooled inserts (Water systems vary with internal or external water delivery.)
- Variety of shapes, sizes, and designs, depending on designated and varying grips

Example

Original prophylaxis

Tip style

Finely beveled internal water delivery tube

Practice Notes

Ultrasonic Scaler Tip—Supragingival is used on hygiene and periodontal tray setups. These tips are also known as ultrasonic inserts.

Sterilization Notes

Ultrasonic Scaler Tip—Supragingival must be precleaned, either, placed in a sterilizing pouch with an internal process indicator, sealed, then sterilized OR wrapped with an internal process indicator inside and secured on the outside with process indicator tape, then sterilized. Verify appropriate color change has been achieved in external process indicator immediately after removal from sterilizer then check internal process indicator before treatment. Refer to state regulations for any additional state requirements.



Instrument

Ultrasonic Scaler Instrument Tip—Subgingival

Functions

To remove subgingival calculus from teeth
To remove bacterial plaque from periodontal pockets

Characteristics

Subgingival Scaler Tip— is inserted into the tubing on the ultrasonic scaling unit.
Available in different lengths (called stacks): 25 kHz or 30 kHz, depending on unit
Water-cooled inserts (Water systems vary with internal or external water delivery.)
Variety of shapes, sizes, and designs, depending on designated area and varying grips

Example

After Five design

Tip style

Finely beveled internal water delivery tube (pictured)

Practice Notes

Ultrasonic Scaler Tip—Subgingival is used on hygiene and periodontal tray setups.
These tips are also known as ultrasonic inserts.

Sterilization Notes

Ultrasonic Scaler Tip—Subgingival must be precleaned, either, placed in a sterilizing pouch with an internal process indicator, sealed, then sterilized OR wrapped with an internal process indicator inside and secured on the outside with process indicator tape, then sterilized. Verify appropriate color change has been achieved in external process indicator immediately after removal from sterilizer then check internal process indicator before treatment. Refer to state regulations for any additional state requirements.



Instrument

Ultrasonic Scaler Instrument Tip—Furcation

Function

To remove bacterial plaque from furcation areas

Characteristics

Furcation Tip is inserted into the tubing on the ultrasonic scaling unit.

Available in different lengths (called stacks): 25 kHz or 30 kHz, depending on unit

Water-cooled inserts (Water systems vary with internal or external water delivery.)

Variety of shapes, sizes, and designs, depending on designated area and varying grips

Example

Furcation Plus design

Tip style

0.8-mm ball end adapts to furcation, external water delivery tube (pictured)

Practice Notes

Ultrasonic Scaler Tip—furcation is used on hygiene and periodontal tray setups.

These tips are also known as ultrasonic inserts.

Pictured: Original Prophy

Sterilization Notes

Ultrasonic Scaler Tip—Furcation must be precleaned, either, placed in a sterilizing pouch with an internal process indicator, sealed, then sterilized OR wrapped with an internal process indicator inside and secured on the outside with process indicator tape, then sterilized. Verify appropriate color change has been achieved in external process indicator immediately after removal from sterilizer then check internal process indicator before treatment. Refer to state regulations for any additional state requirements.



Instrument

Ultrasonic Scaler Instrument Tip—Universal

Function

To remove bacterial plaque and general deposits

Characteristics

Universal tip is inserted into the tubing on the ultrasonic scaling unit.

Available in different lengths (called stacks): 25 kHz or 30 kHz, depending on unit

Water-cooled inserts (Water systems vary with internal or external water delivery.)

Variety of shapes, sizes, and designs, depending on designated area and varying grips

Example

Streamline design

Tip style

Water delivered directly from base of tip, eliminating need for external water system; efficient at low settings (pictured)

Practice Notes

Ultrasonic Scaler Tip—universal is used on hygiene and periodontal tray setups.

These tips are also known as ultrasonic inserts.

Sterilization Notes

Ultrasonic Scaler Tip—Universal must be precleaned, either, placed in a sterilizing pouch with an internal process indicator, sealed, then sterilized OR wrapped with an internal process indicator inside and secured on the outside with process indicator tape, then sterilized. Verify appropriate color change has been achieved in external process indicator immediately after removal from sterilizer then check internal process indicator before treatment. Refer to state regulations for any additional state requirements.

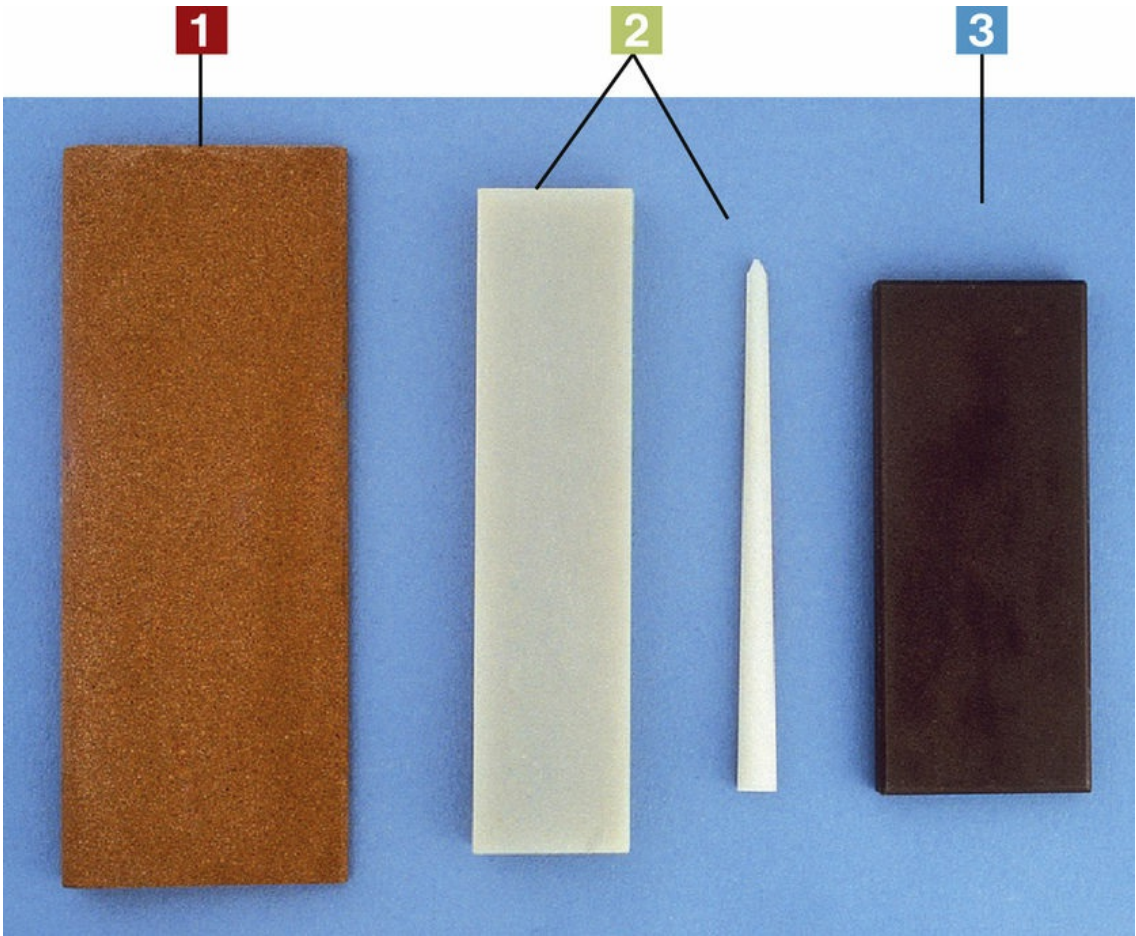

Instrument

Sharpening Stones

Function

To sharpen scalers and curettes

Characteristics

Types of stones:

- India stones—Remove the most metal when used and should be followed with an Arkansas or ceramic stone
- Arkansas stones—Provide a polished edge (flat and cone-shaped pictured)
- Ceramic stones—Provide a polished edge and do not require lubrication

Practice Note

Sharpening Stones are used on hygiene and periodontal tray setups.

Sterilization Notes

Sharpening Stones must be precleaned, either, placed in a sterilizing pouch with an internal process indicator, sealed, then sterilized OR wrapped with an internal process indicator inside and secured on the outside with process indicator tape, then sterilized. Verify appropriate color change has been achieved in external process indicator immediately after removal from sterilizer then check internal process indicator before treatment. Refer to state regulations for any additional state requirements.





Instrument

Battery-Operated Sharpening Device

Function

To sharpen scalers and curettes

Characteristics

Stone moves underneath a stainless-steel guideplate, which puts the blade at factory angles. Sharpener has a power device with instrument guide channels and a vertical backstop to help control blade angulation. (Pictured: Sidekick Sharpener)

Practice Note

Battery-Operated Sharpening Device should be used with sterile scalers and curettes, and then instruments resterilized after sharpening.

Sterilization Notes

Barrier wrap; disinfect or sterilize certain parts of equipment according to the manufacturer's recommendation. Sterilized instruments must be precleaned, either, placed in a sterilizing pouch with an internal process indicator, sealed, then sterilized OR wrapped with an internal process indicator inside and secured on the outside with process indicator tape, then sterilized. Verify appropriate color change has been achieved in external process indicator immediately after removal from sterilizer then check internal process indicator before treatment. Refer to state regulations for any additional state requirements.

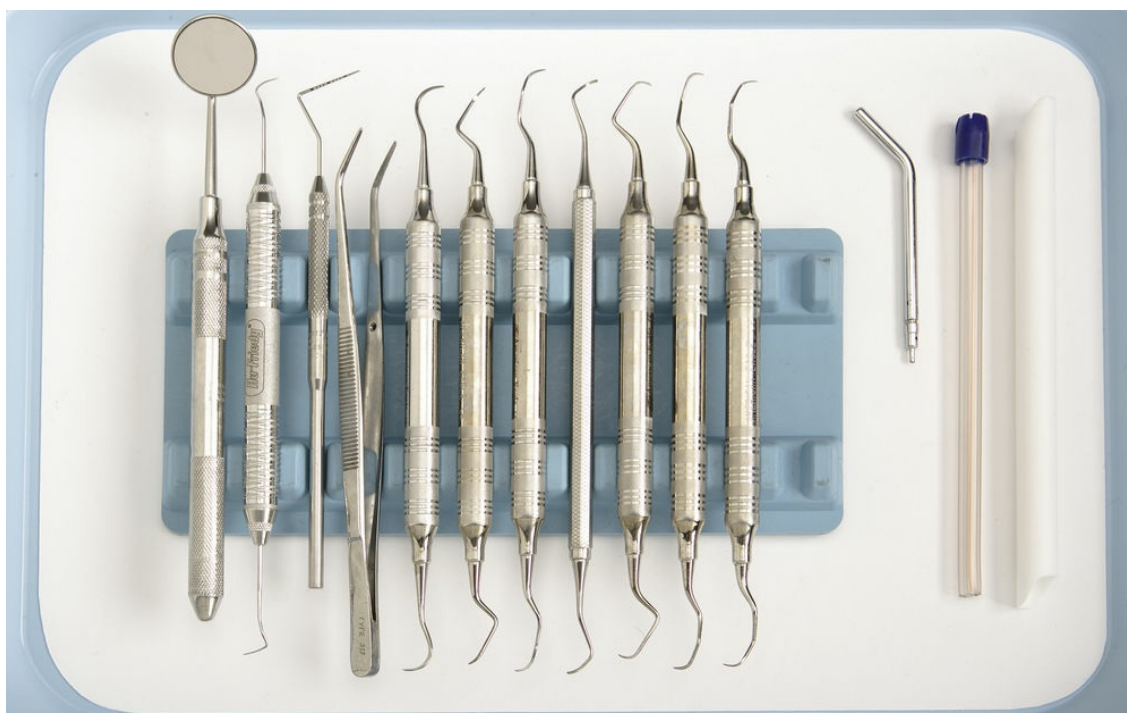

Tray Setup

Hygiene

From Left to Right

Mouth mirror, explorer, periodontal probe, cotton forceps, curved sickle scaler, 4L/4R universal posterior, universal Langer $\frac{1}{2}$, Ratcliff $\frac{3}{4}$, Gracey $\frac{7}{8}$, Gracey $\frac{11}{12}$, Gracey $\frac{13}{14}$, air/water syringe tip, low-volume saliva ejector, high-volume evacuation (HVE) tip

Sterilization Notes

Refer to each picture for correct procedure for instrument sterilization or disposal of instrument or material. Refer to other chapters for additional instruments on this tray setup that are not included in this chapter.



Tray Setup

Root Planing

From Left to Right

Mouth mirror, explorer, periodontal probe, cotton forceps, Gracey $\frac{1}{2}$, Gracey $\frac{3}{4}$, Gracey $\frac{7}{8}$, Gracey $\frac{11}{12}$, Gracey $\frac{13}{14}$, air/water syringe tip, low-volume saliva ejector, high-volume evacuation (HVE) tip

Sterilization Notes

Refer to each individual picture for correct procedure for instrument sterilization or disposal of instrument or material. Refer to other chapters for additional instruments on this tray setup that are not included in this chapter.

Preventive and Sealant Instruments and Whitening Trays



Instrument

Disposables

Functions

To use with all types of dental procedures

To use when area in the mouth needs to stay dry

Characteristics

- Cotton Roll Holder for mandibular arch; one cotton roll is placed on the buccal side of the teeth, and the other is placed on the lingual side of the teeth.
- Disposable Bite Block with ligature tie for safety as to retrieve if patient swallows bite block.
- Cotton Rolls
- Dry Aids for keeping mouth dry—small and large
- Dental floss
- 2 × 2 gauze

Dry Aid is placed on the buccal mucosa—inside the cheek—opposite the maxillary second molar near the Stensen's duct to absorb saliva originating from the parotid gland.

Practice Note

Disposables are used on all dental tray procedures, including sealant and other restorative tray setups.

Sterilization Notes

All Disposables should be disposed of in the garbage. Single use only.



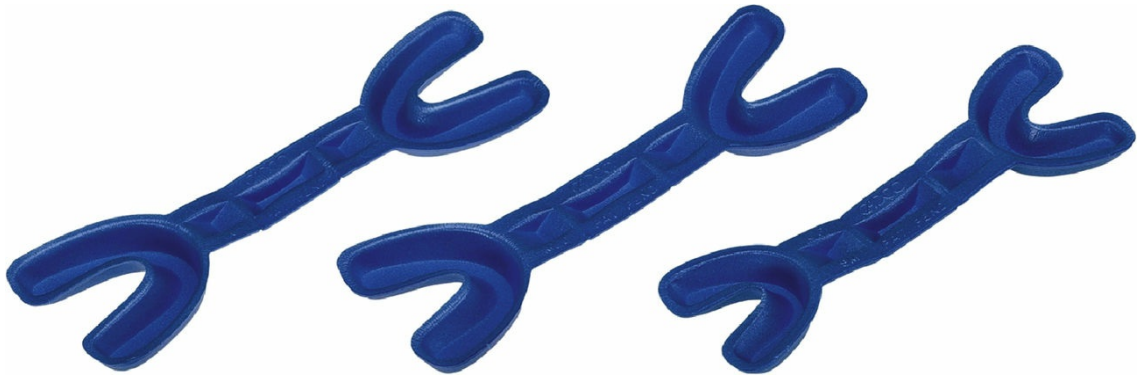

Instrument

Fluoride Trays—Disposable

Functions

To fill trays with fluoride; remineralizing enamel
To help prevent decay by mineralizing the teeth

Characteristic

Variety of disposable trays and fluoride available

Practice Note

Fluoride treatment is usually given to children at their 6-month checkup appointment.
Fluoride Trays are used on fluoride tray setups.

Sterilization Notes

Fluoride Trays should be disposed of in the garbage. Single use only.





Instrument

Vacuum Former

Functions

To make whitening trays, custom temporary crowns, night guards, orthodontic positioners, and mouth guards

To heat plastic square for bleaching trays

To vacuum form the plastic tray over the patient's model to make the bleaching tray and devices as mentioned above

Characteristics

- Heating element that softens the thermoplastic resin
- Handles to pull down plastic
- Vacuum to mold plastic to tray after it is pulled down

Practice Note

Block-out material is light cured on the facial side of the model before whitening trays are made with the vacuum former.

Sterilization Notes

The manufacturer's recommendation should be followed for disinfecting the Vacuum Former.



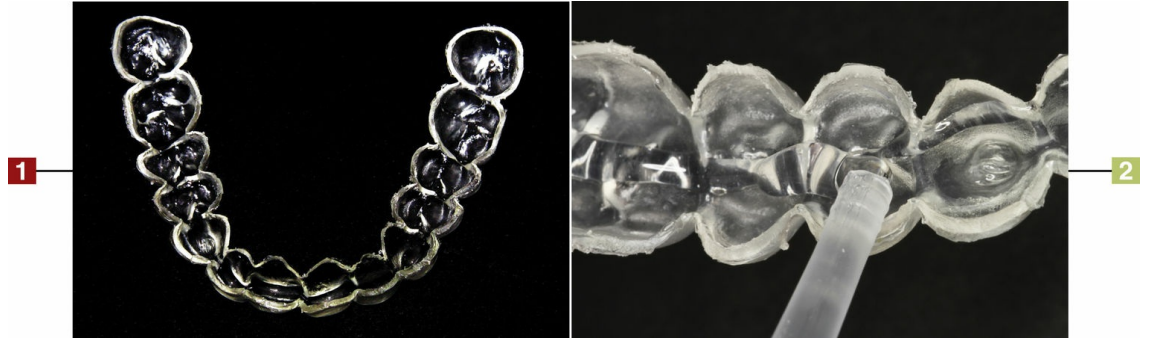

Instrument

Custom-Fitted Whitening Tray

Function

To lighten the color of dark or discolored teeth

Characteristics

- Custom-fitted trays are made in the dental office with the vacuum former.
- Trays hold a peroxide-based gel.

Different percentages of gel available

Usage regimens vary according to dentist recommendations

Practice Note

Bleaching Trays should stop short of the gingival margin of the soft tissues to avoid gingival irritation.

Sterilization Notes

Clean and disinfect according to dentist's recommendation.



Instrument

Scissors—Short Blade

Function

To precisely cut material especially for whitening trays.

Characteristic

Fine cutting blade

Practice Note

Short-Blade Scissors are used on whitening tray setup and on other operative tray setups.

Sterilization Notes

Scissors—Short Blade must be precleaned open and unlocked, placed in an open and unlocked position either in a sterilizing pouch with an internal process indicator, sealed, then sterilized OR wrapped with an internal process indicator inside and secured on the outside with process indicator tape, then sterilized. Verify appropriate color change has been achieved in external process indicator immediately after removal from sterilizer then check internal process indicator before treatment. Refer to state regulations for any additional state requirements.

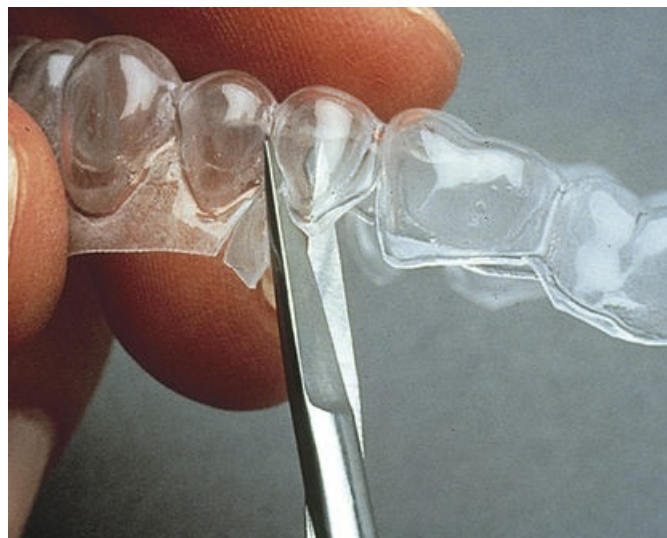



Instrument

DIAGNOdent

Functions

To aid in the detection of caries within the tooth structure
To detect caries in the structure of the tooth before placing sealants

Characteristics

DIAGNOdent accurately diagnoses occlusal caries.
Laser detects the caries in the tooth, and a digital display is seen on the screen.

Practice Note

DIAGNOdent is used with sealant and occasionally restorative tray setups.

Sterilization Notes

The manufacturer's recommendation should be followed for disinfecting DIAGNOdent unit.
Barriers should be placed on wand that is used intraorally. Refer to manufacturer's recommendation for precleaning and sterilization of the DIAGNOdent tips.



Instrument

Spectra Fluorescence Caries Detection Aid System

Functions

To aid in the detection of caries

To aid in the detection of caries during the restorative phase to verify that all caries have been removed.

Characteristics

Components

- Lightweight handpiece with high resolution, auto-exposure CCD sensor
- Spacer that maintains an appropriate distance between the lens tip and the tooth surface and blocks stray light during examinations
- Cable to connect handpiece to computer
 - Uses fluorescence to detect caries in fissures and smooth surfaces
 - Doppler radar-like images provide both color and numerical indicators; in active mode, carious regions appear red, and healthy enamel appears green
 - 120-degree button ring allows the user to freeze, unfreeze, and capture images with one finger.

Practice Note

The Spectra detects decay hidden between the margins of existing composite and amalgam restorations.

Sterilization Notes

The manufacturer's recommendation should be followed for disinfecting Spectra. Barriers should be placed on camera handpiece that is used intraorally. Spacers are reusable however must be precleaned and sterilized before use.



Tray Setup

Prophylaxis Polishing

Top (Left to Right)

Mouth mirror, explorer, cotton forceps, air/water syringe tip, polishing agent without fluoride, dental floss, low-volume saliva ejector, high-volume evacuator (HVE) tip

Bottom (Left to Right)

Prophy slow-speed handpiece with disposable prophy angle attachment with polishing cup, disposable prophy angle attachment with tapered brush

Sterilization Notes

Refer to each picture for correct procedure for instrument sterilization or disposal of instrument or material. Refer to other chapters for additional instruments on this tray setup that are not included in this chapter.



Tray Setup

Sealant

Very Top of Tray

Syringe with etchant

Top Row (Left to Right)

High-volume evacuator tip (HVE), mouth mirror, explorer, cotton forceps, microbrushes, disposable articulating paper holder and articulating paper, air/water syringe tip, dry aids, low-volume evacuator for mandibular, cotton rolls in disposable holder

Bottom Row (Left to Right)

Disposable bite block, dental floss, sealant syringe and syringe tip, prophyl slow-speed handpiece with disposable prophyl angle attachment with polishing cup, disposable prophyl angle attachment with tapered brush

Sterilization Notes

Refer to each picture for correct procedure for instrument sterilization or disposal of instrument or material. Refer to other chapters for additional instruments on this tray setup that are not included in this chapter.



Tray Setup

Whitening

Left to Right

Thermoplastic resin square, bleaching trays (maxillary and mandibular), short-blade scissors, block-out material for models, bleaching trays on maxillary and mandibular models

Sterilization Notes

Refer to each picture for correct procedure for instrument sterilization or disposal of instrument or material. Refer to other chapters for additional instruments on this tray setup that are not included in this chapter.

Orthodontic Instruments

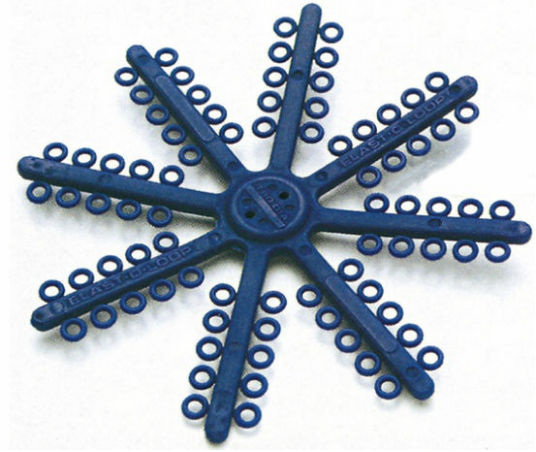

Instrument

Elastic Separators

Functions

To separate teeth before banding a tooth for orthodontic treatment
To place around contact area of tooth

Characteristic

Elastomeric separators— Various sizes for different contact areas

Practice Note

Separators are placed on orthodontic separating tray setup.

Sterilization Notes

Elastomeric Separators should be disposed of in the garbage. Single use only.



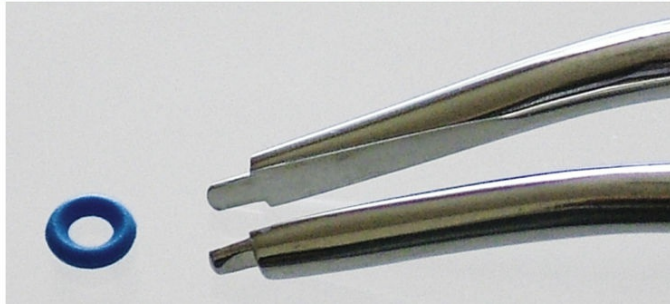
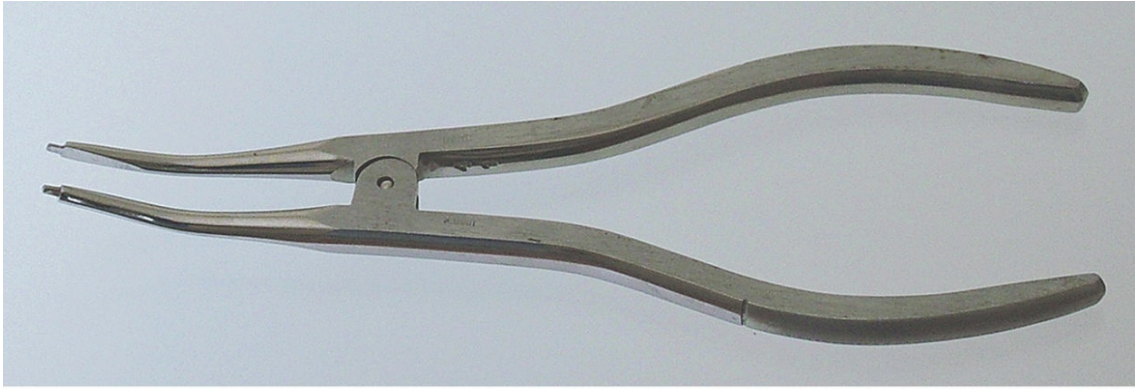

Instrument

Elastic Separating Pliers

Function

To grip and place separators around contact area of tooth

Characteristic

Single ended

Practice Note

Elastic Separating Pliers are only used on the orthodontic tray setup.

Sterilization Notes

Elastic Separating Pliers must be precleaned open and unlocked, placed in an open and unlocked position either in a sterilizing pouch with an internal process indicator, sealed, then sterilized OR wrapped with an internal process indicator inside and secured on the outside with process indicator tape, then sterilized. Verify appropriate color change has been achieved in external process indicator immediately after removal from sterilizer then check internal process indicator before treatment. Refer to state regulations for any additional state requirements.



Instrument

Steel Spring Separators/Brass Wire Separators

Functions

To separate teeth before banding a tooth for orthodontic treatment
To place around contact area of tooth

Characteristics

- Steel Spring Separators— Various sizes for different-sized contact areas
- Brass Wire Separators— Placed around contact and twisted clockwise and then cut 3 mm and tucked in order not to impinge on tissue or occlusion
Placed with orthodontic hemostat or bird beak pliers

Practice Note

Separators are placed on orthodontic separating tray setup.

Sterilization Notes

Steel Spring Separators and Brass Wire Separators should be disposed of in a sharps container.
Single use only.



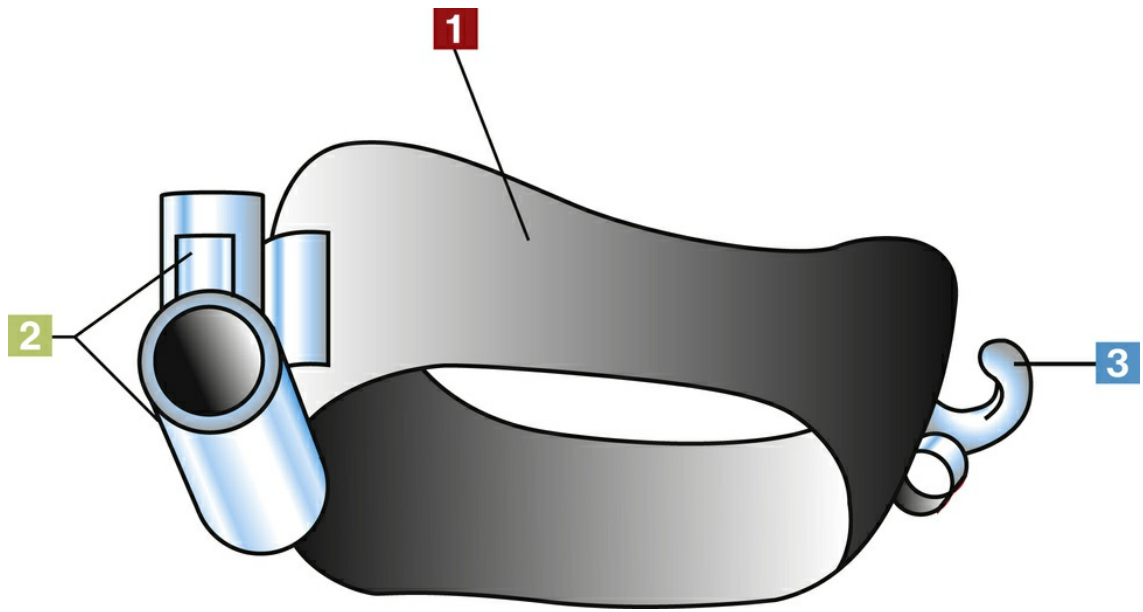

Instrument

Orthodontic Band with Tubing and Hook

Functions

To fit and cement or bond band around the middle third of the coronal part of the tooth
To hold orthodontic arch wire in place (arch wire moves the teeth, many different shapes and sizes)
To secure headgear in tubing on band

Characteristics

- Band
- Tubing:
 - Arch wire tube (top) – Holds arch wire in place
 - Headgear tube (bottom) – Holds headgear in place
- Hook – Place where elastics are attached. Example: Class II, Class III pull

Practice Note

Orthodontic Band is used on orthodontic banding tray setup.

Sterilization Notes

Orthodontic Band should be disposed of in a sharps container. Single use only.



Instrument

Band Pusher

Function

To push orthodontic bands into place during try-in and cementing phases

Characteristic

Single or double ended

Practice Note

Band Pusher is only used on the orthodontic tray setup.

Sterilization Notes

Band Pusher must be precleaned, either, placed in a sterilizing pouch with an internal process indicator, sealed, then sterilized OR wrapped with an internal process indicator inside and secured on the outside with process indicator tape, then sterilized. Verify appropriate color change has been achieved in external process indicator immediately after removal from sterilizer then check internal process indicator before treatment. Refer to state regulations for any additional state requirements.

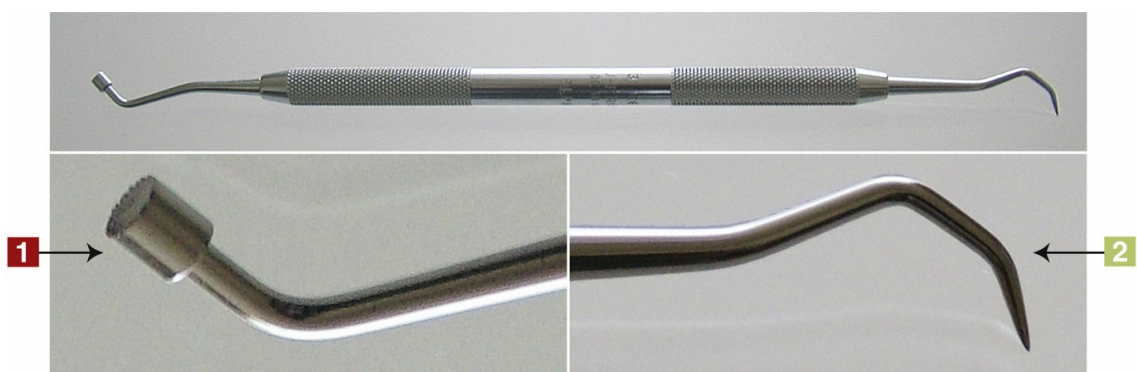

Instrument

Band Pusher or Plugger with Scaler

Functions

To seat or place orthodontic bands during try-in and cementing phases
To remove excess material after cementation or bonding of bands

Characteristics

Double ended:

- Band Pusher or Plugger
- Scaler

Practice Note

Band pusher with scaler is used on the orthodontic tray setup.

Sterilization Notes

Band Pusher or Plugger with Scaler must be precleaned, either, placed in a sterilizing pouch with an internal process indicator, sealed, then sterilized OR wrapped with an internal process indicator inside and secured on the outside with process indicator tape, then sterilized. Verify appropriate color change has been achieved in external process indicator immediately after removal from sterilizer then check internal process indicator before treatment. Refer to state regulations for any additional state requirements.

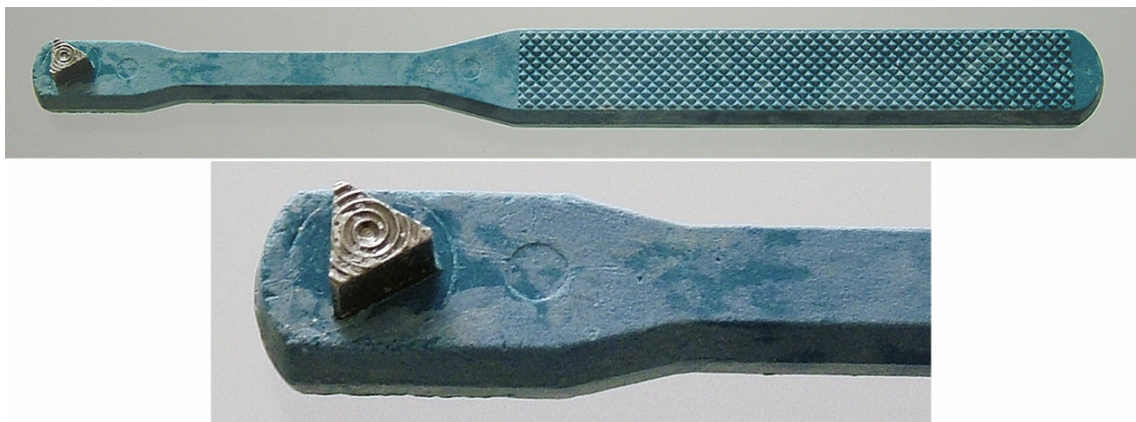

Instrument

Band Seater—Bite Stick

Function

To assist seating or placing of orthodontic bands for try-in or cementing phase

Characteristics

Single ended

Available in square tip or triangle tip (pictured)

Practice Notes

The patient bites down on the smooth end of the instrument to apply pressure to seat the band. Band Seater—Bite Stick is only used on the orthodontic tray setup.

Sterilization Notes

Band Seater—Bite Stick must be precleaned, either, placed in a sterilizing pouch with an internal process indicator, sealed, then sterilized OR wrapped with an internal process indicator inside and secured on the outside with process indicator tape, then sterilized. Verify appropriate color change has been achieved in external process indicator immediately after removal from sterilizer then check internal process indicator before treatment. Refer to state regulations for any additional state requirements.

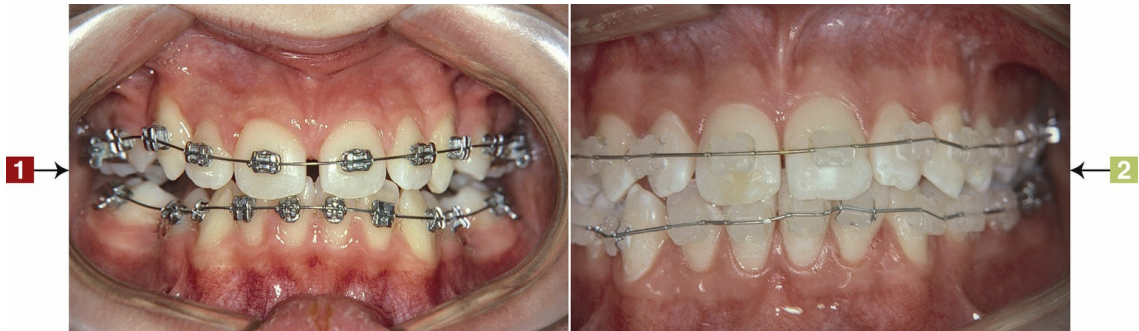

Instrument

Orthodontic Bracket

Function

To hold orthodontic arch wire in place (arch wire moves the teeth)

Characteristics

Bracket is bonded to tooth.

Hold arch wire in place

Many different types available:

- Metal brackets
- Ceramic brackets (for esthetic purposes)

Practice Note

Orthodontic Brackets are used on orthodontic bonding tray setup.

Sterilization Notes

Orthodontic Brackets should be disposed of in a sharps container. Single use only.





Instrument

Bracket Placement Card

Function

To place each bracket and/or band on card according to tooth placement in mouth

Characteristic

Tape on card holds brackets in place before they are bonded to teeth.

Practice Note

Bracket Placement Card is only used on the orthodontic tray setup.

Sterilization Notes

Bracket Placement Card should be disposed of in the garbage. Single use only.

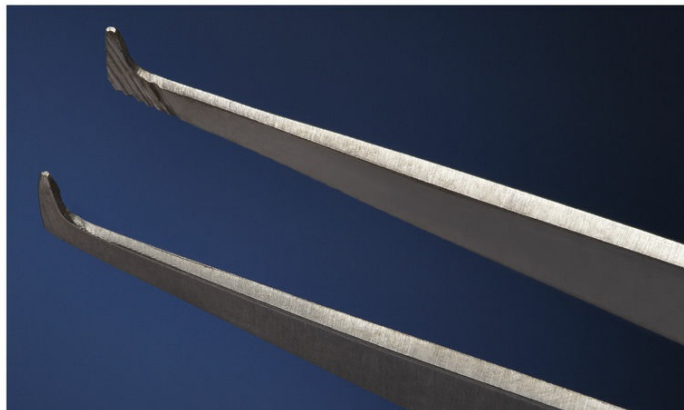

Instrument

Posterior Bracket Placement Pliers

Functions

To hold and carry bracket by placing tip of pliers into slot of bracket
To place bracket on tooth for bonding

Characteristic

Range of sizes

Practice Note

Posterior Bracket Placement Pliers are only used on the orthodontic tray setup.

Sterilization Notes

Posterior Bracket Placement Pliers must be precleaned open and unlocked, placed in an open and unlocked position either in a sterilizing pouch with an internal process indicator, sealed, then sterilized OR wrapped with an internal process indicator inside and secured on the outside with process indicator tape, then sterilized. Verify appropriate color change has been achieved in external process indicator immediately after removal from sterilizer then check internal process indicator before treatment. Refer to state regulations for any additional state requirements.



Instrument

Anterior Bracket Placement Pliers

Functions

To hold and carry bracket by placing tip of pliers into slot of bracket
To place bracket on tooth for bonding

Characteristic

Range of sizes

Practice Note

Anterior Bracket Placement Pliers are only used on the orthodontic tray setup.

Sterilization Notes

Anterior Bracket Placement Pliers must be precleaned open and unlocked, placed in an open and unlocked position either in a sterilizing pouch with an internal process indicator, sealed, then sterilized OR wrapped with an internal process indicator inside and secured on the outside with process indicator tape, then sterilized. Verify appropriate color change has been achieved in external process indicator immediately after removal from sterilizer then check internal process indicator before treatment. Refer to state regulations for any additional state requirements.

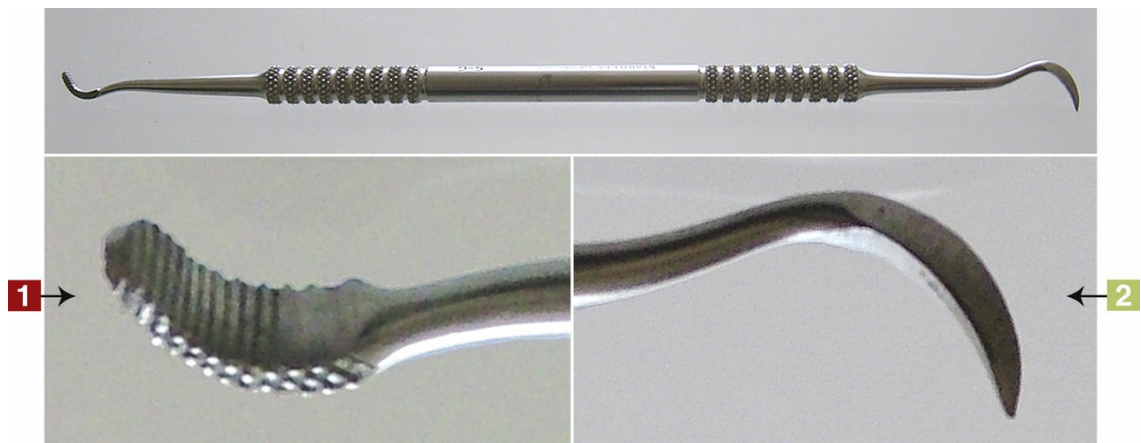

Instrument

Orthodontic (Shure) Scaler

Functions

- To place brackets for bonding (both ends)
- To remove separators (scaler end)
- To remove elastic ligature ties (scaler end)
- To remove excess cement or bonding material (scaler end)
- To check for loose bands and brackets (both ends)

Characteristics

Universal instrument used for several orthodontic functions

Single ended—Scaler or band pusher

Double ended:

- Band pusher
- Orthodontic scaler

Practice Note

Orthodontic Scaler is used on the orthodontic tray setup.

Sterilization Notes

Orthodontic Scaler must be precleaned, either, placed in a sterilizing pouch with an internal process indicator, sealed, then sterilized OR wrapped with an internal process indicator inside and secured on the outside with process indicator tape, then sterilized. Verify appropriate color change has been achieved in external process indicator immediately after removal from sterilizer then check internal process indicator before treatment. Refer to state regulations for any additional state requirements.



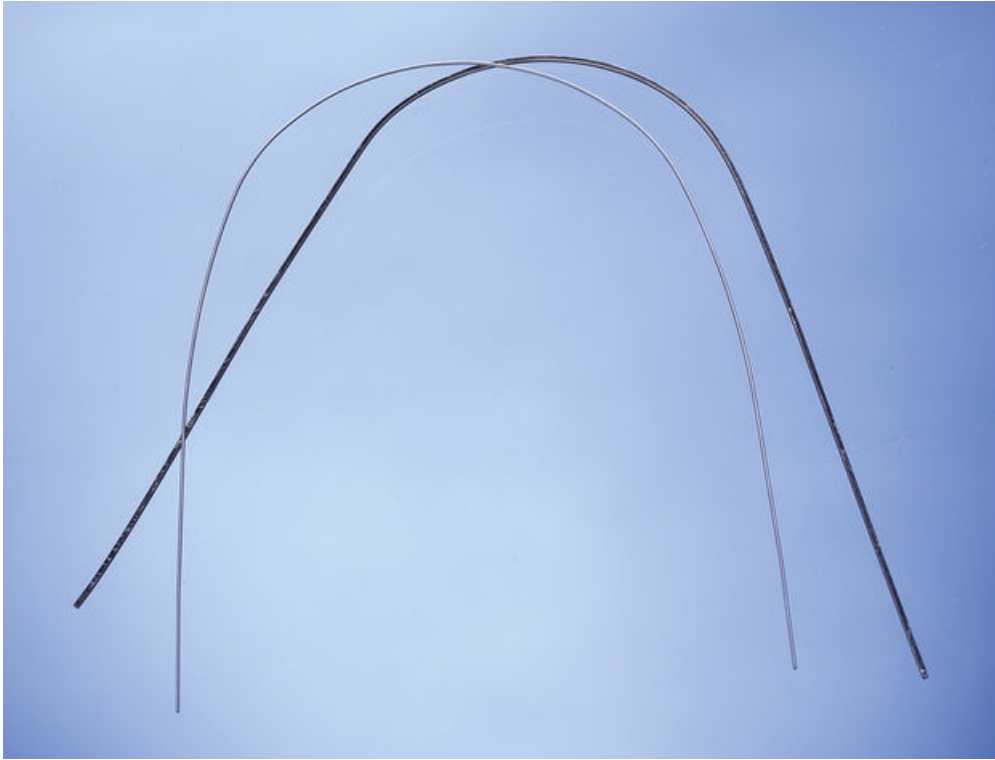

Instrument

Arch Wire

Function

To place into slots of each bracket and secure with a wire or elastomeric ligature tie on every bracket

To move teeth with the force of the arch wire

Characteristics

Different types of arch wire available according to stage of the orthodontic treatment

Nickel titanium—Flexible wire

Stainless steel wire—Stiff and stronger than other types of wire

Beta titanium—Combination of flexibility, strength, and memory

Optiflex—Made from composite material for light force (initial stages) and esthetic purposes

Different shapes and thickness in diameter available according to initial, intermediate, and advanced treatment:

Round wire—Initial and intermediate stages of treatment

Square, rectangular—Final stages of treatment

Practice Note

Arch Wire is used during all phases of orthodontic treatment when brackets and bands are placed on the teeth.

Sterilization Notes

Arch Wire must be disposed of in a sharps container.



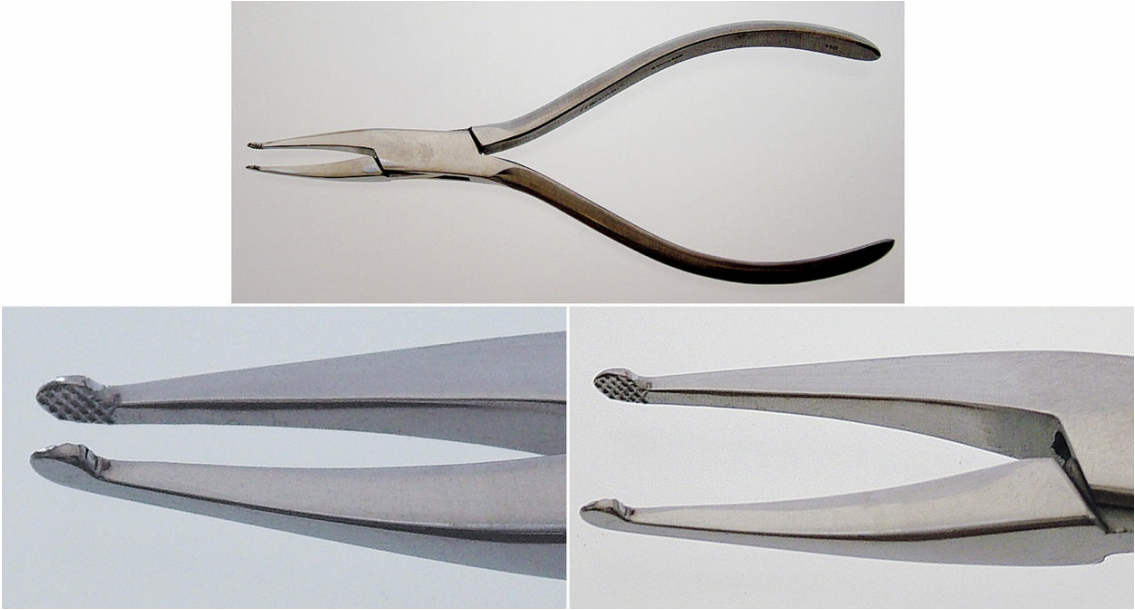

Instrument

How (or Howe) Pliers

Functions

To place and remove arch wires
To check for loose bands

Characteristics

All-purpose pliers for orthodontic procedures
Serrated tips for better grip on wire
Straight or curved beaks

Practice Note

How Pliers are only used on the orthodontic tray setup.

Sterilization Notes

How Pliers must be precleaned open and unlocked, placed in an open and unlocked position either in a sterilizing pouch with an internal process indicator, sealed, then sterilized OR wrapped with an internal process indicator inside and secured on the outside with process indicator tape, then sterilized. Verify appropriate color change has been achieved in external process indicator immediately after removal from sterilizer then check internal process indicator before treatment. Refer to state regulations for any additional state requirements.

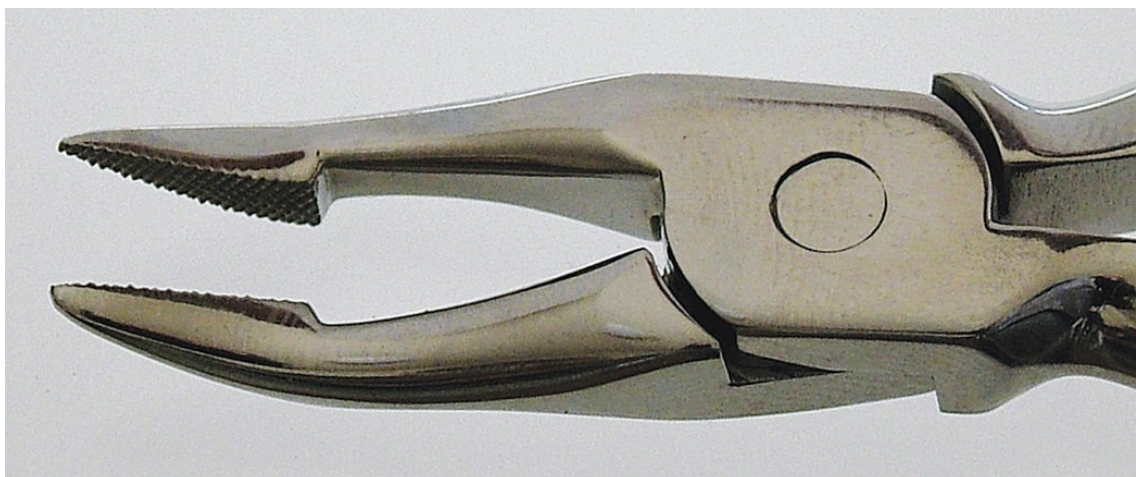

Instrument

Weingart Utility Pliers

Functions

- To place and remove arch wires
- To aid a variety of functions for orthodontic procedures
- To remove bonded brackets by squeezing bracket

Characteristic

Working ends—Tapered, slim tips to allow pliers to fit between brackets for ease of arch wire placement

Practice Note

Weingart Utility Pliers are only used on the orthodontic tray setup.

Sterilization Notes

Weingart Utility Pliers must be precleaned open and unlocked, placed in an open and unlocked position either in a sterilizing pouch with an internal process indicator, sealed, then sterilized OR wrapped with an internal process indicator inside and secured on the outside with process indicator tape, then sterilized. Verify appropriate color change has been achieved in external process indicator immediately after removal from sterilizer then check internal process indicator before treatment. Refer to state regulations for any additional state requirements.

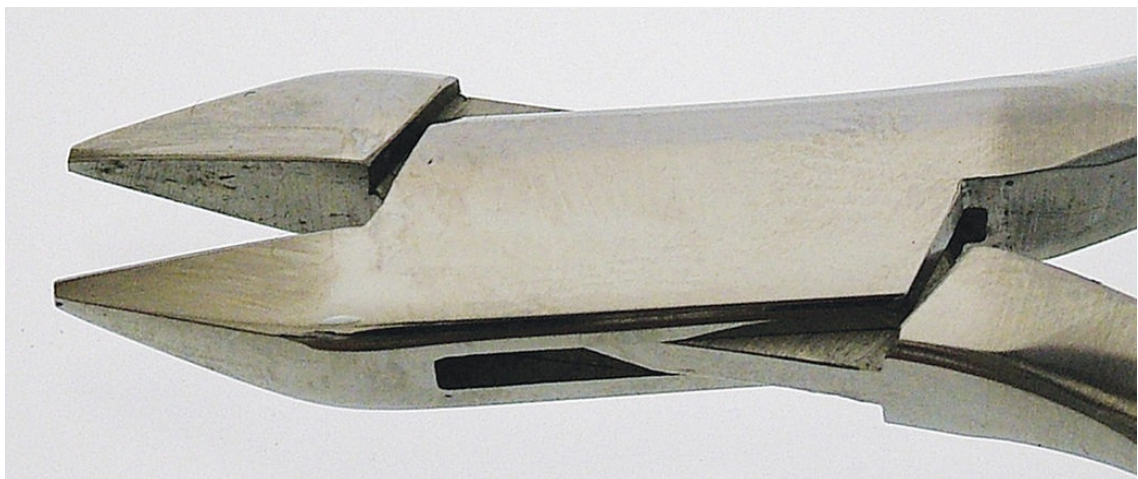

Instrument

Arch-Bending Pliers

Function

To bend arch wires

Characteristic

Variety of styles, depending on type of arch wire used—Round, square, or rectangular

Practice Note

Arch-Bending Pliers are only used on the orthodontic tray setup.

Sterilization Notes

Arch-Bending Pliers must be precleaned open and unlocked, placed in an open and unlocked position either in a sterilizing pouch with an internal process indicator, sealed, then sterilized OR wrapped with an internal process indicator inside and secured on the outside with process indicator tape, then sterilized. Verify appropriate color change has been achieved in external process indicator immediately after removal from sterilizer then check internal process indicator before treatment. Refer to state regulations for any additional state requirements.



Instrument

Tweed Loop-Forming Pliers (Jarabak Pliers)

Functions

To bend and form loops in arch wire
To bend wires for removable appliances

Characteristics

Grooves in beak—Help to bend and form loops in wire
Variety of styles

Practice Note

Tweed Loop-Forming Pliers are only used on the orthodontic tray setup.

Sterilization Notes

Tweed Loop-Forming Pliers must be precleaned open and unlocked, placed in an open and unlocked position either in a sterilizing pouch with an internal process indicator, sealed, then sterilized OR wrapped with an internal process indicator inside and secured on the outside with process indicator tape, then sterilized. Verify appropriate color change has been achieved in external process indicator immediately after removal from sterilizer then check internal process indicator before treatment. Refer to state regulations for any additional state requirements.





Instrument

Three-Prong Pliers

Function

To contour and bend light wire

Characteristic

Range of sizes available

Practice Note

Three-Prong Pliers are only used on the orthodontic tray setup.

Sterilization Notes

Three-Prong Pliers must be precleaned open and unlocked, placed in an open and unlocked position either in a sterilizing pouch with an internal process indicator, sealed, then sterilized OR wrapped with an internal process indicator inside and secured on the outside with process indicator tape, then sterilized. Verify appropriate color change has been achieved in external process indicator immediately after removal from sterilizer then check internal process indicator before treatment. Refer to state regulations for any additional state requirements.

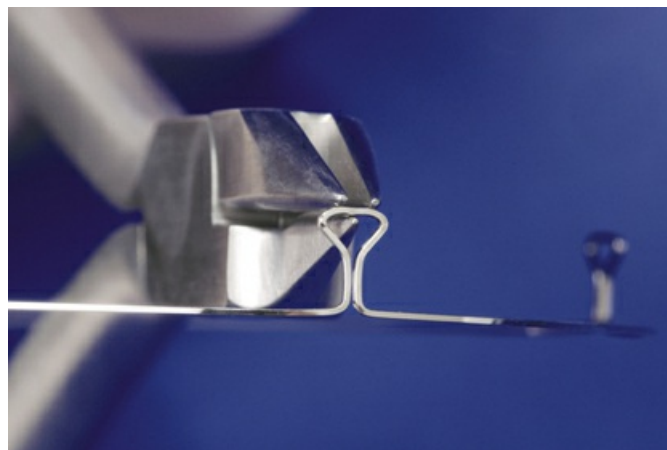

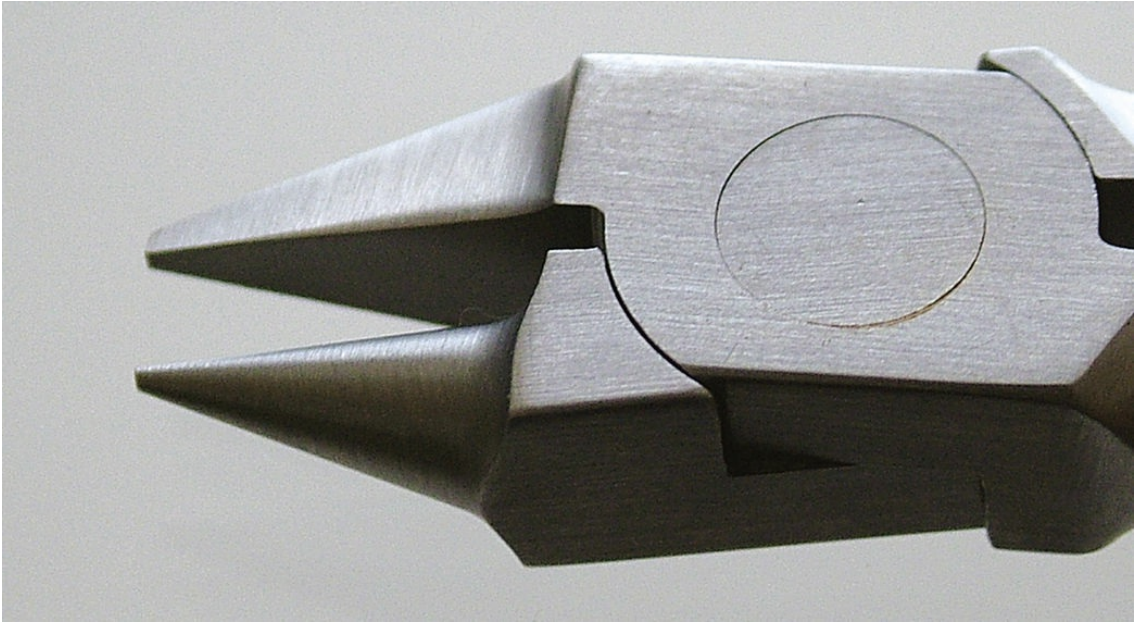

Instrument

Bird Beak Pliers

Functions

To bend and form orthodontic wire
To remove bonded bracket by squeezing bracket

Characteristics

Versatile wire-bending pliers
Beaks on working end meet very precisely

Practice Note

Bird Beak Pliers are only used on the orthodontic tray setup.

Sterilization Notes

Bird Beak Pliers must be precleaned open and unlocked, placed in an open and unlocked position either in a sterilizing pouch with an internal process indicator, sealed, then sterilized OR wrapped with an internal process indicator inside and secured on the outside with process indicator tape, then sterilized. Verify appropriate color change has been achieved in external process indicator immediately after removal from sterilizer then check internal process indicator before treatment. Refer to state regulations for any additional state requirements.



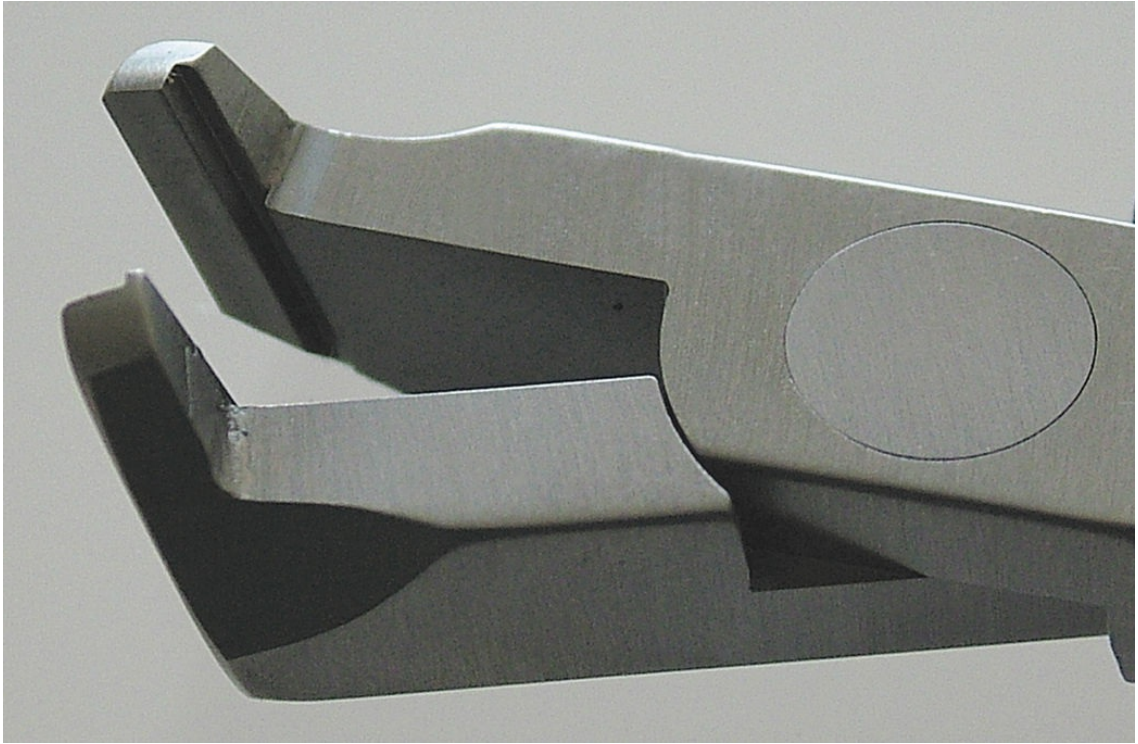

Instrument

Distal End-Cutting Pliers

Function

To cut distal end of arch wire after placement in brackets and buccal tubes

Characteristic

Catch and hold excess wire after wire has been cut

Practice Note

Distal End-Cutting Pliers are only used on the orthodontic tray setup.

Sterilization Notes

Distal End-Cutting Pliers must be precleaned open and unlocked, placed in an open and unlocked position either in a sterilizing pouch with an internal process indicator, sealed, then sterilized OR wrapped with an internal process indicator inside and secured on the outside with process indicator tape, then sterilized. Verify appropriate color change has been achieved in external process indicator immediately after removal from sterilizer then check internal process indicator before treatment. Refer to state regulations for any additional state requirements.

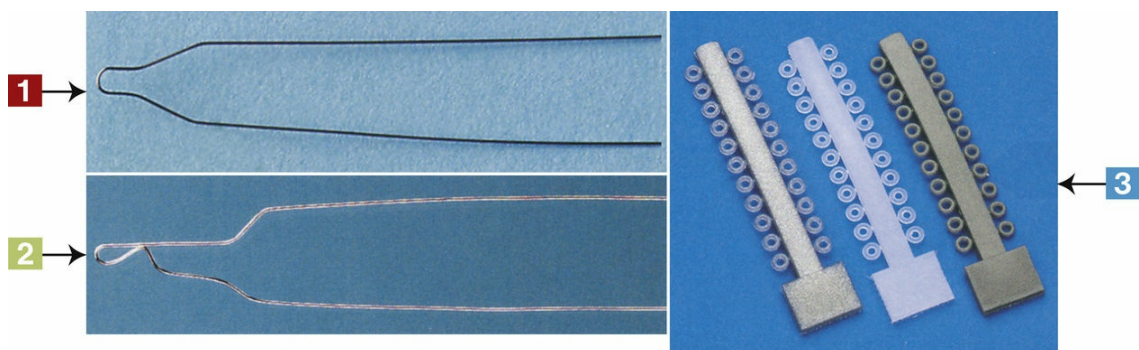

Instrument

Ligatures Ties

Function

To secure the arch wire to the band or bracket

Characteristics

- Wire Ligature Ties
Thin, flexible wire
Comes in precut length or spools
- Kobayashi Ties
Preformed hook
- Elastic Ligature Ties
Available in different colors
Comes on a stick (pictured), canes, and chains

Practice Note

Ligature Ties are used on the orthodontic archwire placement tray setup.

Sterilization Notes

Wire Ligature Ties must be disposed of in a sharps container. Elastic ligature ties should be disposed of in garbage.

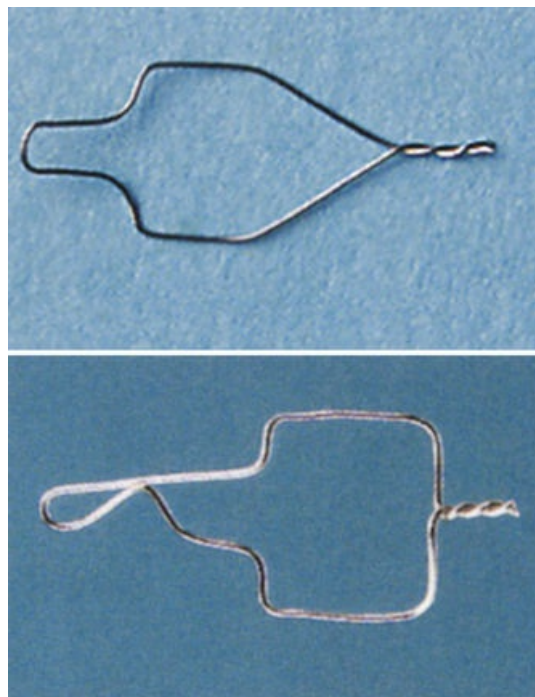

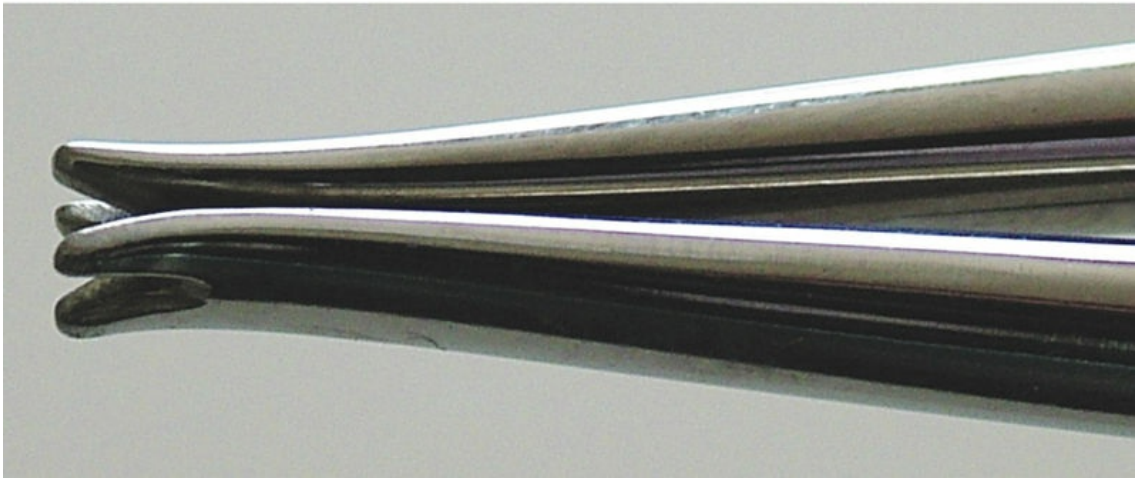

Instrument

Ligature-Tying (Coon) Pliers

Function

To tie in ligature to arch wire

Characteristics

Channel on pliers—Locks wire ends in place as tips spread
Variety of styles

Practice Note

Ligature-Tying Pliers are only used on the orthodontic tray setup.

Sterilization Notes

Ligature-Tying Pliers must be precleaned open and unlocked, placed in an open and unlocked position either in a sterilizing pouch with an internal process indicator, sealed, then sterilized OR wrapped with an internal process indicator inside and secured on the outside with process indicator tape, then sterilized. Verify appropriate color change has been achieved in external process indicator immediately after removal from sterilizer then check internal process indicator before treatment. Refer to state regulations for any additional state requirements.



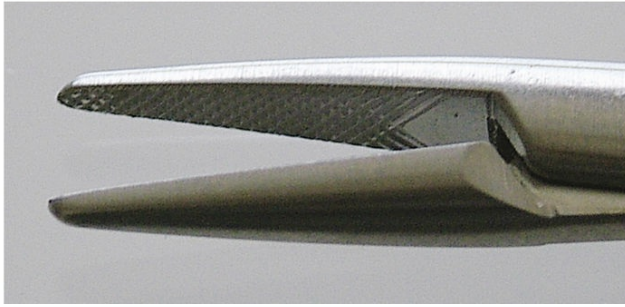
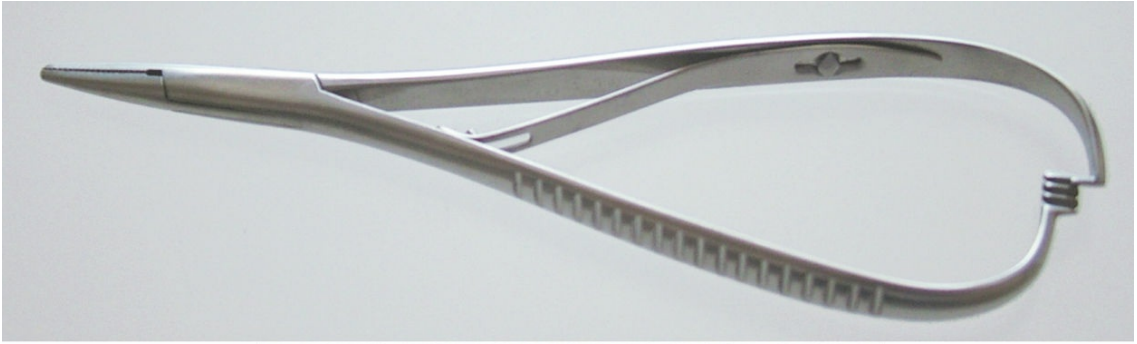

Instrument

Orthodontic Hemostat

Functions

To hold and place separators
To hold, place, and/or tie ligatures to arch wire

Characteristic

Multifunctional instrument for orthodontic procedures

Example

Mathieu pliers

Practice Note

Orthodontic Hemostat is used on the orthodontic tray setup.

Sterilization Notes

Orthodontic Hemostat must be precleaned open and unlocked, placed in an open and unlocked position either in a sterilizing pouch with an internal process indicator, sealed, then sterilized OR wrapped with an internal process indicator inside and secured on the outside with process indicator tape, then sterilized. Verify appropriate color change has been achieved in external process indicator immediately after removal from sterilizer then check internal process indicator before treatment. Refer to state regulations for any additional state requirements.



Instrument

Ligature/Wire Cutters

Functions

To cut ligature after it has been tied to arch wire
To cut ligature tie to allow removal of arch wire

Characteristic

Range of sizes available

Practice Note

Ligature/Wire Cutters are used on the orthodontic tray setup.

Sterilization Notes

Ligature/Wire Cutters must be precleaned open and unlocked, placed in an open and unlocked position either in a sterilizing pouch with an internal process indicator, sealed, then sterilized OR wrapped with an internal process indicator inside and secured on the outside with process indicator tape, then sterilized. Verify appropriate color change has been achieved in external process indicator immediately after removal from sterilizer then check internal process indicator before treatment. Refer to state regulations for any additional state requirements.

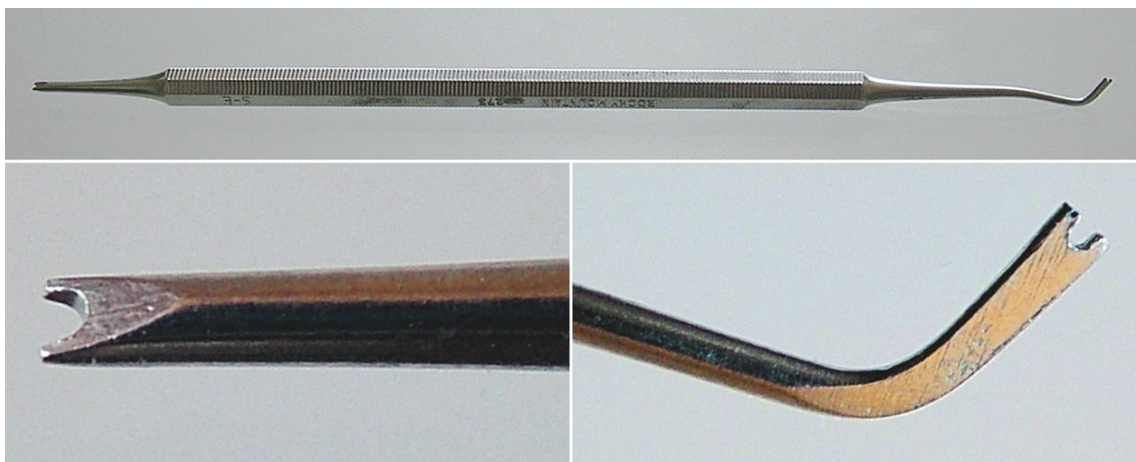
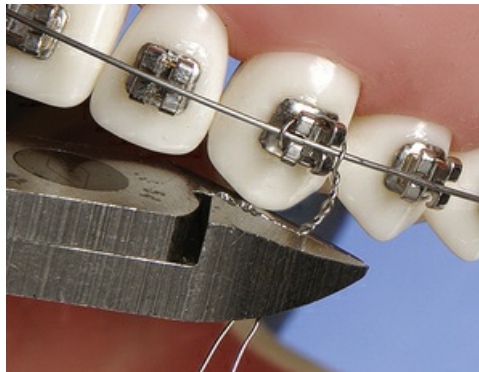

Instrument

Ligature Director

Function

To place ligature wire around brackets after it has been tied to arch wire

Characteristics

Single or double ended

Ends of instrument—Have notches to assist placement of ligature tie around brackets

Practice Note

Ligature Director is used on the orthodontic archwire placement tray setup.

Sterilization Notes

Ligature Director must be precleaned, either, placed in a sterilizing pouch with an internal process indicator, sealed, then sterilized OR wrapped with an internal process indicator inside and secured on the outside with process indicator tape, then sterilized. Verify appropriate color change has been achieved in external process indicator immediately after removal from sterilizer then check internal process indicator before treatment. Refer to state regulations for any additional state requirements.



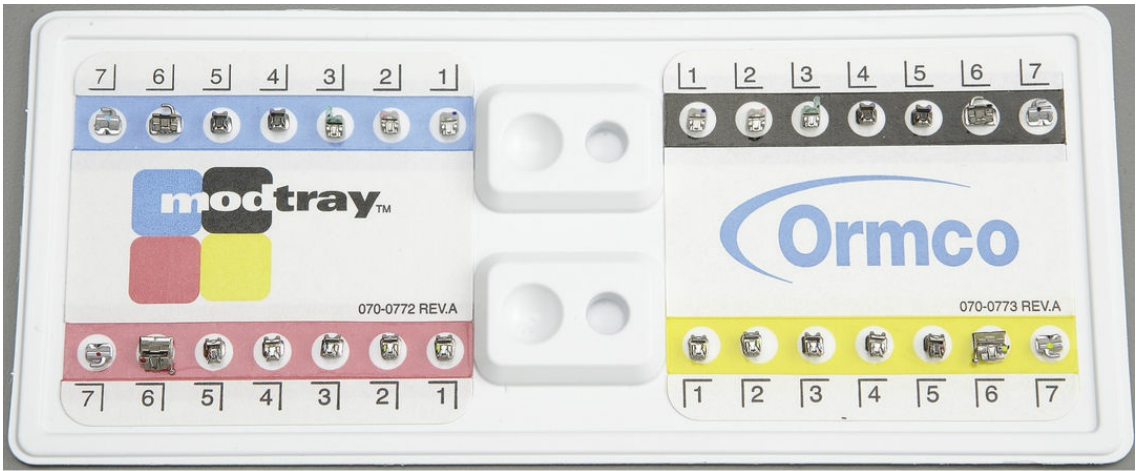

Instrument

Bracket Placement Card for Damon Self-Ligating Brackets with Self-Ligating Instrument

Functions

To place each bracket on card according to tooth placement in mouth
Self-Ligating Instrument— To close bracket around arch wire; ligature tie not needed

Characteristic

Tape on card holds brackets in place before they are bonded to teeth.

Practice Note

Bracket Placement Card and self-ligating instrument are used only on orthodontic bonding bracket tray setup.

Sterilization Notes

Bracket Placement Card should be disposed of in the garbage. Single use only. Self-ligating instrument must be precleaned, either, placed in a sterilizing pouch with an internal process indicator, sealed, then sterilized OR wrapped with an internal process indicator inside and secured on the outside with process indicator tape, then sterilized. Verify appropriate color change has been achieved in external process indicator immediately after removal from sterilizer then check internal process indicator before treatment. Refer to state regulations for any additional state requirements.



GAC APPLIANCES

Standard Edge
 Roth
 Single Wing
 Other _____

.018" slot
 .022" slot
 Post 3-4-5
 Post 3 only

UR UL

5 4 3 2 1 1 2 3 4 5

LR LL

355 KNICKERBOCKER AVENUE
BOHEMIA, NY 11716
1-631-419-1700

international, inc.



Instrument

Self-Ligating Brackets with Self-Ligating Instrument

Functions

To place each bracket on card according to tooth placement in mouth

Instrument—To open and close bracket around arch wire; ligature tie not needed

Characteristic

Tape on card holds brackets in place before they are bonded to teeth.

Practice Note

Bracket Placement Card and self-ligating instrument are used only on orthodontic bonding bracket tray setup.

Sterilization Notes

Bracket Placement Card should be disposed of in the garbage. Single use only. Self-ligating instrument must be precleaned, either, placed in a sterilizing pouch with an internal process indicator, sealed, then sterilized OR wrapped with an internal process indicator inside and secured on the outside with process indicator tape, then sterilized. Verify appropriate color change has been achieved in external process indicator immediately after removal from sterilizer then check internal process indicator before treatment. Refer to state regulations for any additional state requirements.





Instrument

Lip Retractors

Functions

To retract lips, allowing for intraoral access for bonding brackets
To retract lips for intraoral orthodontic photographs

Characteristics

- Reusable Lip Retractors
- Disposable Lip Retractors

Practice Note

Lip Retractors are used with orthodontic procedures and other tray setups that include taking intraoral photographs.

Sterilization Notes

Reusable Lip Retractors must be precleaned, either, placed in a sterilizing pouch with an internal process indicator, sealed, then sterilized OR wrapped with an internal process indicator inside and secured on the outside with process indicator tape, then sterilized. Verify appropriate color change has been achieved in external process indicator immediately after removal from sterilizer then check internal process indicator before treatment. Refer to state regulations for any additional state requirements. Disposable Lip Retractors should be disposed of in garbage.



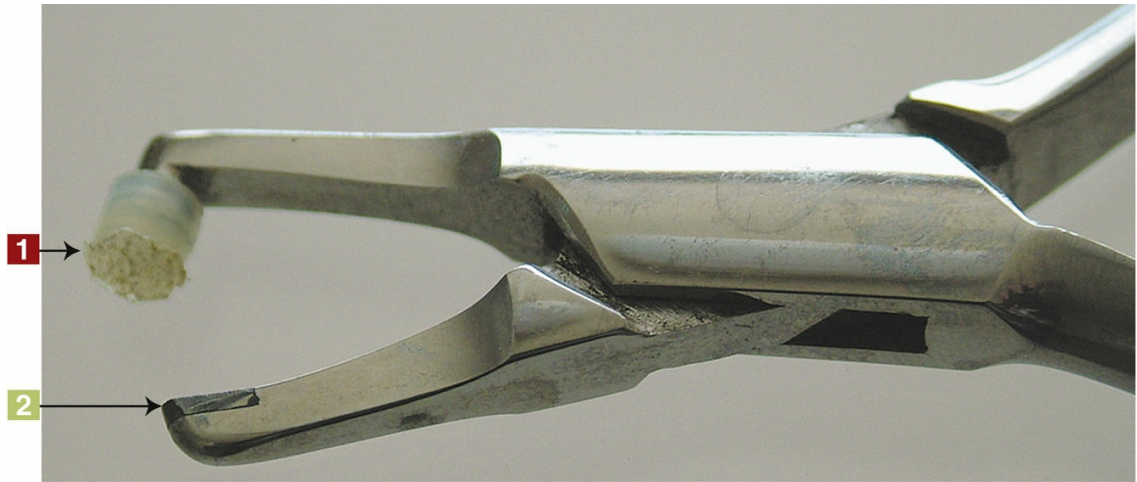

Instrument

Posterior Band Remover

Function

To remove orthodontic bands from teeth

Characteristics

Two beak types:

- One beak has round cover to place on occlusal surface of tooth to prevent damage during removal of band. Cover can be replaced.
- Opposite beak is curved and is placed on gingival side of bracket to apply pressure and remove band from tooth.

Practice Note

Posterior Band Remover is used on the orthodontic tray setup.

Sterilization Notes

Posterior Band Remover must be precleaned open and unlocked, placed in an open and unlocked position either in a sterilizing pouch with an internal process indicator, sealed, then sterilized OR wrapped with an internal process indicator inside and secured on the outside with process indicator tape, then sterilized. Verify appropriate color change has been achieved in external process indicator immediately after removal from sterilizer then check internal process indicator before treatment. Refer to state regulations for any additional state requirements.

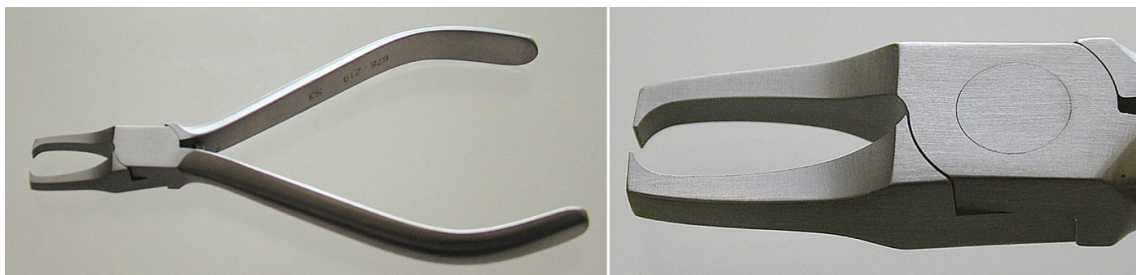

Instrument

Bracket Remover

Function

To remove anterior or posterior brackets from teeth

Characteristic

Grasp bracket to remove it from tooth.

Practice Note

Bracket Remover is used on the orthodontic tray setup.

Sterilization Notes

Bracket Remover must be precleaned open and unlocked, placed in an open and unlocked position either in a sterilizing pouch with an internal process indicator, sealed, then sterilized OR wrapped with an internal process indicator inside and secured on the outside with process indicator tape, then sterilized. Verify appropriate color change has been achieved in external process indicator immediately after removal from sterilizer then check internal process indicator before treatment. Refer to state regulations for any additional state requirements.

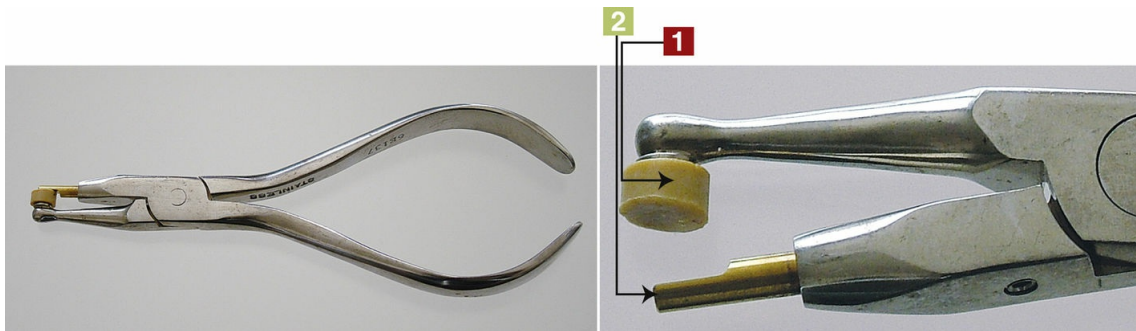

Instrument

Adhesive-Removing Pliers

Function

To remove excess adhesive after debonding of brackets

Characteristics

- Plastic pad on round end (pad can be changed)
- Carbide-inserted tip on short beak—Used to remove the bulk of composite material after debonding

Practice Note

Adhesive-Removing Pliers are used on the orthodontic tray setup.

Sterilization Notes

Adhesive-Removing Pliers must be precleaned open and unlocked, placed in an open and unlocked position either in a sterilizing pouch with an internal process indicator, sealed, then sterilized OR wrapped with an internal process indicator inside and secured on the outside with process indicator tape, then sterilized. Verify appropriate color change has been achieved in external process indicator immediately after removal from sterilizer then check internal process indicator before treatment. Refer to state regulations for any additional state requirements.



Instrument

Invisalign and CEREC Omnicam

Function

To take images with an intraoral Wand/Camera of the maxillary and mandibular arches. Images are sent to the computer.

To send images to a lab to manufacture
Invisalign appliances

Characteristics

- Wand/Camera that captures images connected to the computer
- Cerec Omnicam captures the images of teeth in the maxillary and mandibular arches for Invisalign orthodontic appliances that move teeth for Orthodontic procedures.
- Invisalign appliance
- Traditional orthodontics
 - Images are sent to the lab to manufacture a series of Invisalign appliances for Orthodontic movement of the teeth.

Practice Note

The CEREC Omnicam is used mainly for Orthodontic Invisalign appliances

Sterilization Notes

Barriers should be used for the intraoral Wand/Camera. Barriers or overgloves should be used for manipulating the computer on the Cerec Omnicam. Otherwise, refer to the manufacturer's recommendation for disinfecting.

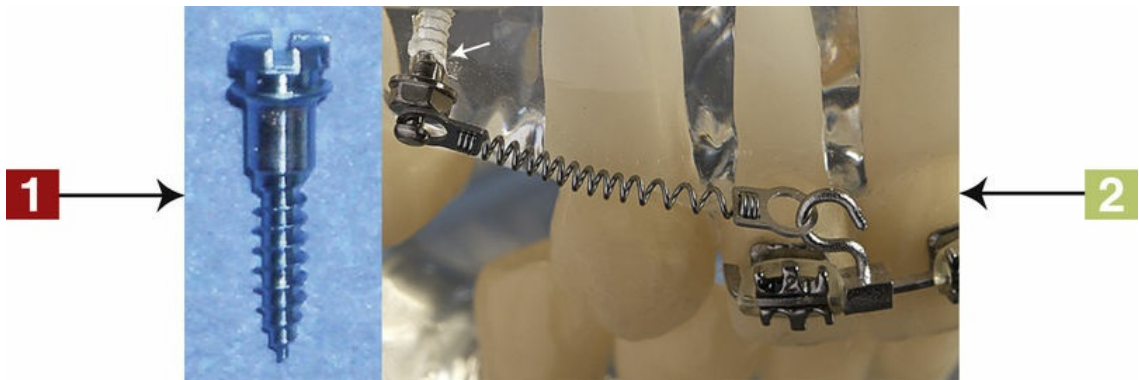

Instrument

Temporary Anchorage Device (TAD)

Function

To aid in the movement of teeth with skeletal anchorage assisting in orthodontic treatment

Some examples of TAD:

- Closure of space between teeth
- Tooth uprighting
- Open bite correction
- To provide an anchor point to move teeth

Characteristics

- TAD
- TAD (arrow) inserted for movement of teeth TADs are small titanium anchors also referred to as mini implants or mini screws. Before placement, chlorhexidine solution (an antibacterial solution) is placed on the area before anesthesia.
TAD surgery procedure is referred by the orthodontist to a periodontist or a maxillofacial surgeon.

Practice Note

TADs are used with periodontal and maxillofacial surgery setups, oral surgery or periodontal surgery setup, and orthodontic tray setups.

Sterilization Notes

TADs must be disposed of in Sharps container. Single use only. Refer to state regulations for any additional state requirements.



Tray Setup

Orthodontic Tooth Separating

Top

Elastic separators, spring coil separators

Bottom (Left to Right)

Mouth mirror, explorer, cotton forceps (pliers), orthodontic (Shure) scaler, elastic separating pliers, floss, orthodontic hemostat (Mathieu pliers), air/water syringe tip, low-volume saliva ejector tip, high-volume evacuation (HVE) tip

Sterilization Notes

Refer to each individual picture for correct procedure for instrument sterilization or disposal of instrument or material. Refer to other chapters for additional instruments on this tray setup that are not included in this chapter.



Tray Setup

Orthodontic Cementing and Bonding Brackets

Top Row (Left to Right)

Bracket placement card with brackets, orthodontic bands, polishing agent without fluoride or glycerin, disposable prophyl angle with polishing cup, air/water syringe tip

Bottom Row (Left to Right)

Mouth mirror, explorer, cotton forceps, orthodontic scaler (Shure scaler), band seater-bite stick, posterior band remover, anterior bracket placement pliers, posterior bracket placement pliers, flexible cement spatula, low-volume saliva ejector, high-volume evacuation (HVE) tip, microbrushes, disposable cheek retractors

Sterilization Notes

Refer to each individual picture for correct procedure for instrument sterilization or disposal of instrument or material. Refer to other chapters for additional instruments on this tray setup that are not included in this chapter.



Tray Setup

Orthodontic Tying-In Arch Wire

Top (Left to Right)

Prefformed archwire, elastic ligature ties

Bottom (Left to Right)

Mouth mirror, explorer, cotton forceps, orthodontic (Shure) scaler, ligature director, wire ligature ties, orthodontic hemostat (Mathieu pliers), (under orthodontic hemostat, short wire ligature ties), ligature-tying (Coon) pliers, bird beak pliers, arch-bending pliers, distal-end cutting pliers, How (Howe) pliers, ligature/wire cutters

Sterilization Notes

Refer to each picture for correct procedure for instrument sterilization or disposal of instrument or material. Refer to other chapters for additional instruments on this tray setup that are not included in this chapter.



Tray Setup

Orthodontic Removing Bands and Brackets

Left to Right

Mouth mirror, explorer, cotton forceps, orthodontic (Shure) scaler, posterior band remover, bird beak pliers, universal curette, low-volume saliva ejector, high-volume evacuation (HVE) tip, air/water syringe tip

Sterilization Notes

Refer to each picture for correct procedure for instrument sterilization or disposal of instrument or material. Refer to other chapters for additional instruments on this tray setup that are not included in this chapter.

Universal Surgical Instruments



Instrument

Mouth Prop

Function

To hold patient's mouth open during dental procedures

Characteristics

Placed in posterior part of mouth while patient bites down
Often used for sedated patients
Disposable mouth props available
Range of sizes—Pediatric to large adult

Practice Notes

Mouth Prop could be used with any dental procedure, including but not exclusive to operative or surgical.

Ligate with floss for safety of patient choking.

Sterilization Notes

Mouth Prop must be precleaned, either, placed in a sterilizing pouch with an internal process indicator, sealed, then sterilized OR wrapped with an internal process indicator inside and secured on the outside with process indicator tape, then sterilized. Verify appropriate color change has been achieved in external process indicator immediately after removal from sterilizer then check internal process indicator before treatment. Refer to state regulations for any additional state requirements. Disposable Mouth Props should be disposed of in garbage. Single use only.

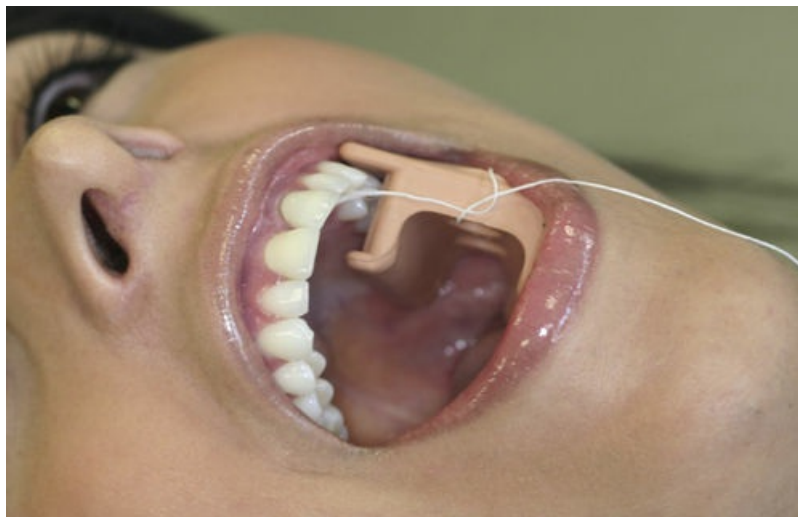



Instrument

Mouth Gag

Function

To hold patient's mouth open during dental procedures

Characteristics

Often used for sedated patients

Locking device

Range of sizes available

Practice Note

Mouth Gag is mostly used for oral surgery and periodontal surgical procedures when patient is sedated.

Sterilization Notes

Mouth Gag must be precleaned open and unlocked, placed in an open and unlocked position either in a sterilizing pouch with an internal process indicator, sealed, then sterilized OR wrapped with an internal process indicator inside and secured on the outside with process indicator tape, then sterilized. Verify appropriate color change has been achieved in external process indicator immediately after removal from sterilizer then check internal process indicator before treatment. Refer to state regulations for any additional state requirements.



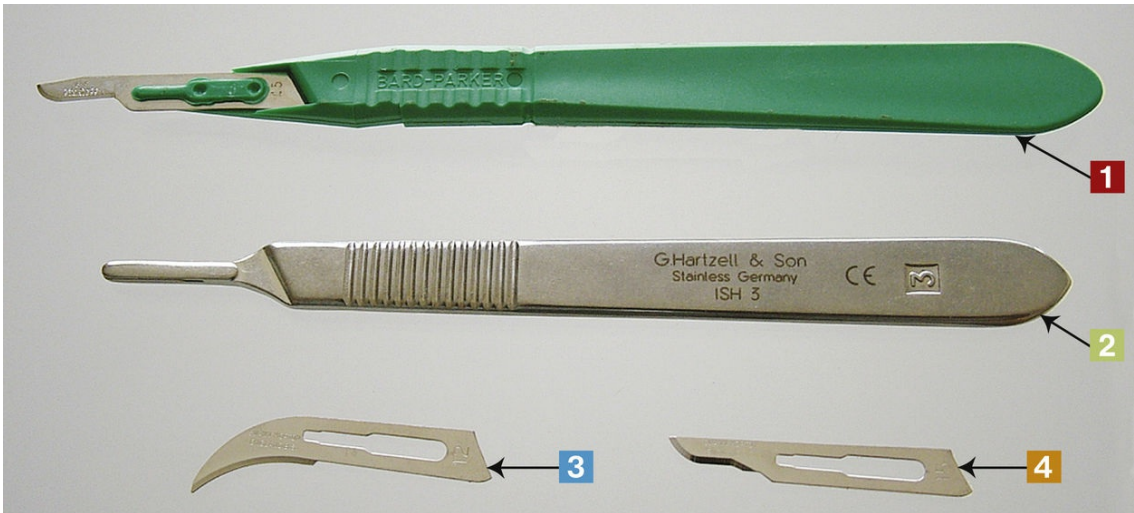

Instrument

Scalpel Handle with Blades

Functions

Handle:

To hold blade in place

Blades:

To cut tissue with blade

To trim interproximal restorations

Characteristics

- Disposable Handle/Blade in one unit
- Scalpel Handle
 - Blades—Disposable, variety of shapes and sizes:
 - #12 Blade
 - #15 Blade

Practice Note

Scalpel with Blades mostly used on oral surgery and periodontal surgical tray setups and occasionally used with composite tray setups for removing flash material and interproximal carving.

Sterilization Notes

Scalpel Handle must be precleaned, either, placed in a sterilizing pouch with an internal process indicator, sealed, then sterilized OR wrapped with an internal process indicator inside and secured on the outside with process indicator tape, then sterilized. Verify appropriate color change has been achieved in external process indicator immediately after removal from sterilizer then check internal process indicator before treatment. Refer to state regulations for any additional state requirements. Scalpel blade must be disposed of in a sharps container. Disposable handle and blade in one unit must be disposed of in a sharps container.





Instrument

Scalpel Blade Remover

Function

To safely remove blade from scalpel handle

Characteristics

Removes all sizes of blades
Autoclavable

Practice Notes

Steps for removing blade:

- Insert blade with blade side up; align to notch.
- Press down on blade remover.
- Pull handle away from blade.

Scalpel Blade Remover is mostly used on oral surgery and periodontal surgical tray setups.

Sterilization Notes

Scalpel Blade Remover must be precleaned, either, placed in a sterilizing pouch with an internal process indicator, sealed, then sterilized OR wrapped with an internal process indicator inside and secured on the outside with process indicator tape, then sterilized. Verify appropriate color change has been achieved in external process indicator immediately after removal from sterilizer then check internal process indicator before treatment. Refer to state regulations for any additional state requirements. Scalpel blade must be disposed of in a sharps container.

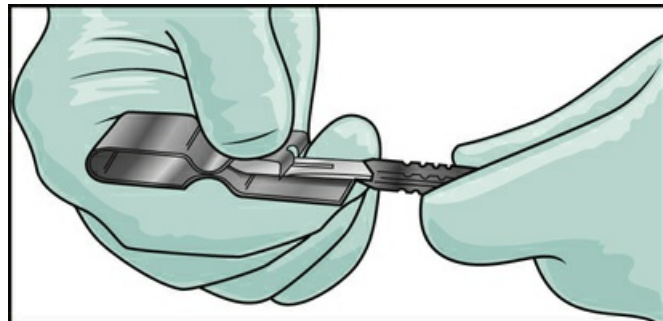



Instrument

Tissue Scissors

Function

To cut tissue

Characteristics

Straight or curved

Variety of shapes and sizes

Variety of uses

Practice Note

Tissue Scissors are mostly used on oral surgery and periodontal surgical tray setups.

Sterilization Notes

Tissue Scissors must be precleaned open and unlocked, placed in an open and unlocked position either in a sterilizing pouch with an internal process indicator, sealed, then sterilized OR wrapped with an internal process indicator inside and secured on the outside with process indicator tape, then sterilized. Verify appropriate color change has been achieved in external process indicator immediately after removal from sterilizer then check internal process indicator before treatment. Refer to state regulations for any additional state requirements.

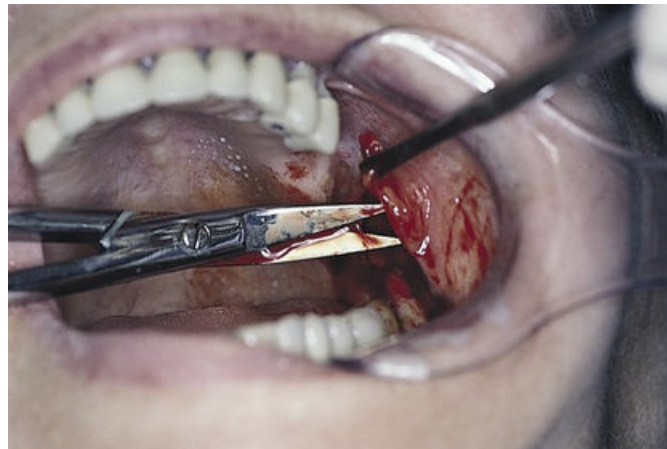

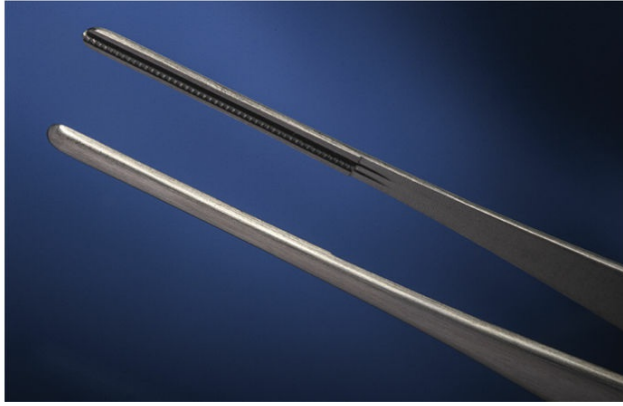
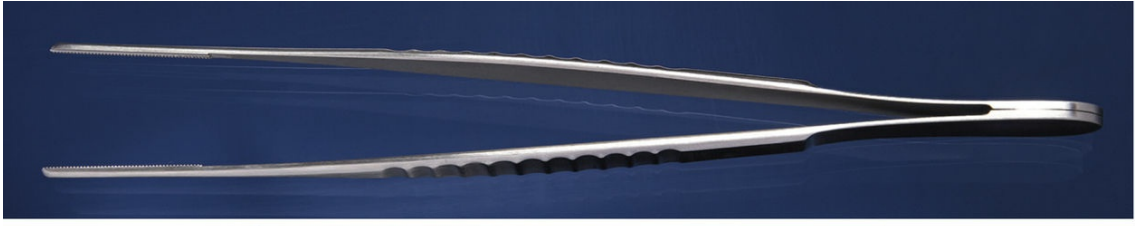

Instrument

Tissue Forceps

Function

To hold tissue during surgical procedures

Characteristics

Serrated or rat-tooth tips
Range of sizes available

Practice Note

Tissue Forceps are mostly used on oral surgery and periodontal surgical tray setups.

Sterilization Notes

Tissue Forceps must be precleaned, either, placed in a sterilizing pouch with an internal process indicator, sealed, then sterilized OR wrapped with an internal process indicator inside and secured on the outside with process indicator tape, then sterilized. Verify appropriate color change has been achieved in external process indicator immediately after removal from sterilizer then check internal process indicator before treatment. Refer to state regulations for any additional state requirements.





Instrument

Hemostat

Function

To grasp tissue or bone fragments
To hold and grasp material in and out of the oral cavity

Characteristics

Straight or curved
Working end—Serrated and/or locking
Variety of functions in other dental procedures
Range of sizes available

Practice Notes

Hemostat is mostly used on oral surgery and periodontal surgical tray setups.
Hemostat is also used on restorative and many other tray setups.

Sterilization Notes

Hemostat must be precleaned open and unlocked, placed in an open and unlocked position either in a sterilizing pouch with an internal process indicator, sealed, then sterilized OR wrapped with an internal process indicator inside and secured on the outside with process indicator tape, then sterilized. Verify appropriate color change has been achieved in external process indicator immediately after removal from sterilizer then check internal process indicator before treatment. Refer to state regulations for any additional state requirements.



Instrument

Periosteal Elevator

Functions

To separate tissue from tooth or bone
To hold tissue away from surgical site

Characteristics

Working end—Pointed or round
Range of sizes available

Practice Note

Periosteal Elevator is used on oral surgery and periodontal surgical tray setups.

Sterilization Notes

Periosteal Elevator must be precleaned, either, placed in a sterilizing pouch with an internal process indicator, sealed, then sterilized OR wrapped with an internal process indicator inside and secured on the outside with process indicator tape, then sterilized. Verify appropriate color change has been achieved in external process indicator immediately after removal from sterilizer then check internal process indicator before treatment. Refer to state regulations for any additional state requirements.

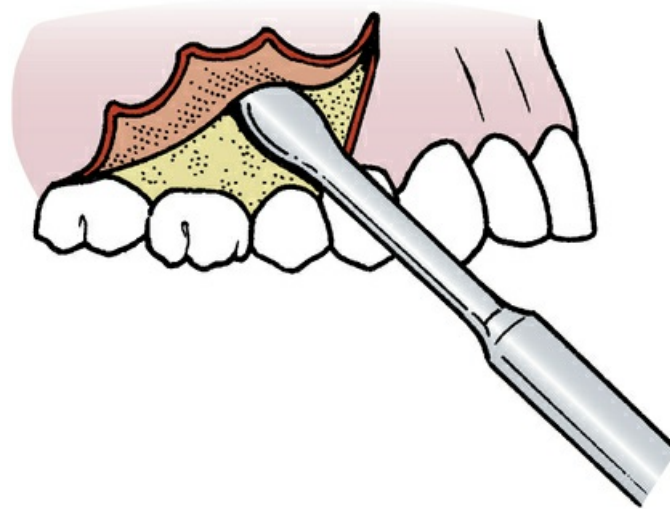

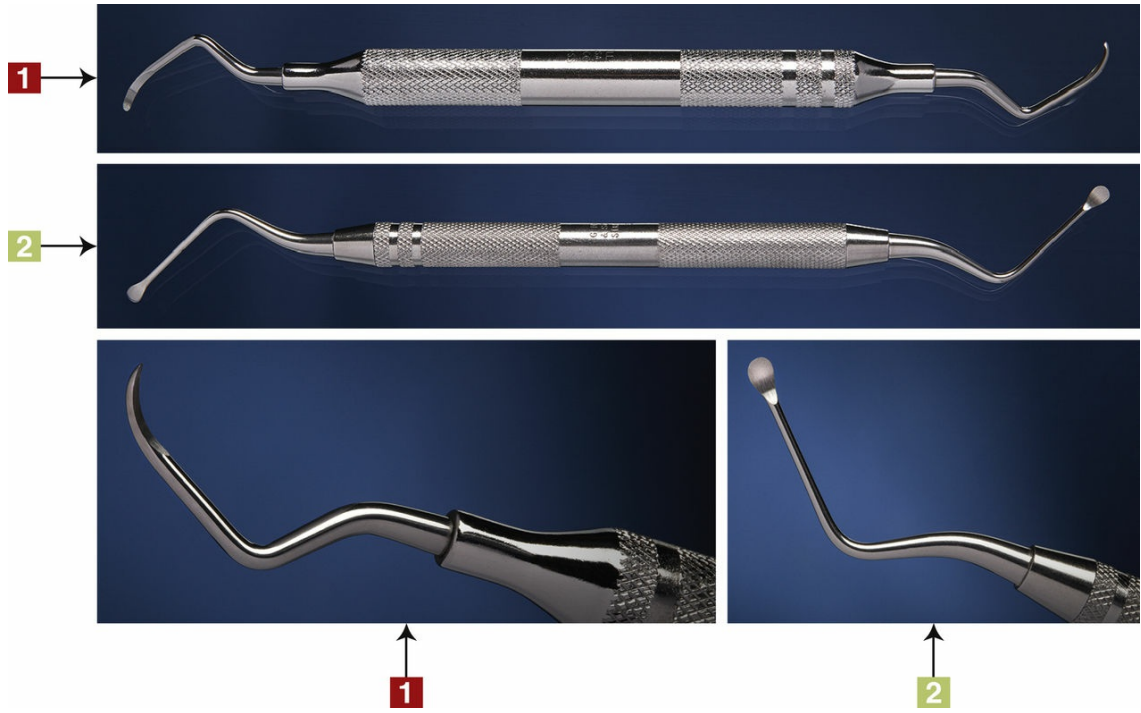

Instrument

Surgical Curette

Functions

To remove debris or granulation tissue from surgical site
To remove cyst from extraction site or surgical site
To perform gross tissue débridement

Characteristics

Single or double ended
Variety of sizes and shapes
Examples of commonly used types:

- Prichard
- Miller

Practice Note

Surgical Curette is mostly used on oral surgery and periodontal surgical tray setups.

Sterilization Notes

Surgical Curette must be precleaned, either, placed in a sterilizing pouch with an internal process indicator, sealed, then sterilized OR wrapped with an internal process indicator inside and secured on the outside with process indicator tape, then sterilized. Verify appropriate color change has been achieved in external process indicator immediately after removal from sterilizer then check internal process indicator before treatment. Refer to state regulations for any additional state requirements.



Instrument

Tongue and Cheek Retractor

Function

To hold and retract tongue or cheek during surgery

Characteristic

Variety of styles and sizes

Example of commonly used type: Minnesota (pictured)

Practice Note

Tongue and Cheek Retractor is mostly used on oral surgery and periodontal surgical tray setups.

Sterilization Notes

Tongue and Cheek Retractor must be precleaned, either, placed in a sterilizing pouch with an internal process indicator, sealed, then sterilized OR wrapped with an internal process indicator inside and secured on the outside with process indicator tape, then sterilized. Verify appropriate color change has been achieved in external process indicator immediately after removal from sterilizer then check internal process indicator before treatment. Refer to state regulations for any additional state requirements.



Instrument

Surgical Needle Holder

Function

To grasp and manipulate suture needle during use

Characteristics

Working end—Different lengths, curved or straight

Notched ends available (to accommodate needle)

Range of sizes—Micro for microsurgery to large

Variety of styles:

- Universal
- Castroviejo

Practice Note

Needle Holder is mostly used on oral surgery and periodontal surgical tray setups.

Sterilization Notes

Needle Holder must be precleaned open and unlocked, placed in an open and unlocked position either in a sterilizing pouch with an internal process indicator, sealed, then sterilized OR wrapped with an internal process indicator inside and secured on the outside with process indicator tape, then sterilized. Verify appropriate color change has been achieved in external process indicator immediately after removal from sterilizer then check internal process indicator before treatment. Refer to state regulations for any additional state requirements.



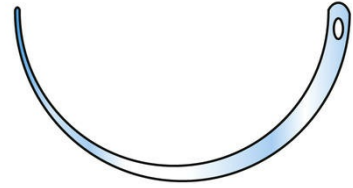
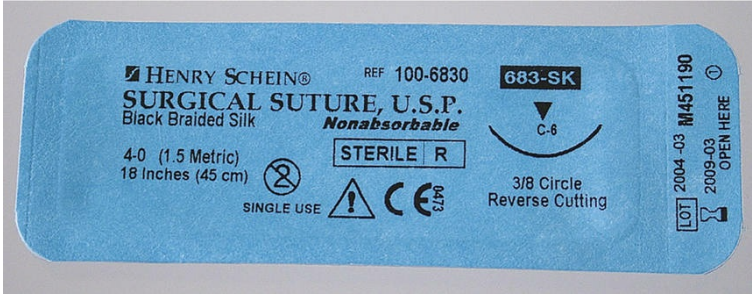
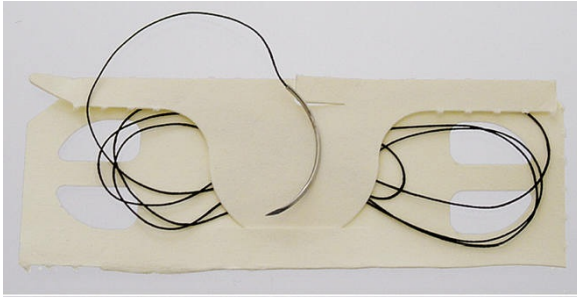

Instrument

Suture Needle and Sutures

Function

To suture surgical site

Characteristics

Resorbable sutures— Gut plain, chromic gut, polyglycolic acid (PGA)

Nonresorbable sutures— Silk, nylon, polyester, polypropylene

Available in sterile package

Variety of suture needle sizes available with different sutures

Practice Note

Suture Needle and Sutures are mostly used on oral surgery and periodontal surgical tray setups.

Sterilization Notes

Suture Needle and Sutures must be disposed of in a sharps container.

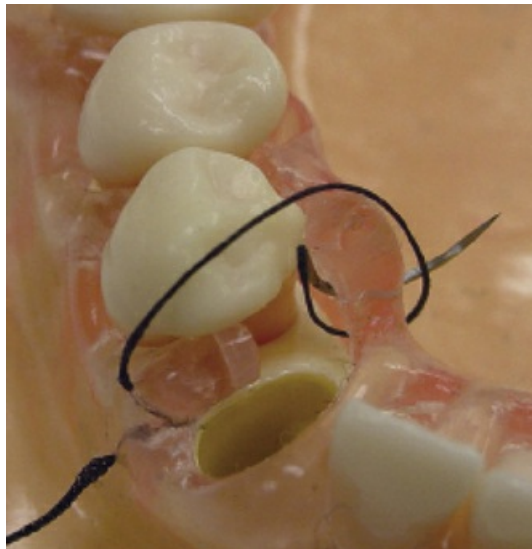



Instrument

Suture Scissors

Function

To cut sutures

Characteristics

Cutting edges—Straight or angled

May have notch on end of cutting edge (shown in picture)

Range of sizes

Practice Note

Suture Scissors are mostly used on oral surgery and periodontal surgical tray setups.

Sterilization Notes

Suture Scissors must be precleaned open and unlocked, placed in an open and unlocked position either in a sterilizing pouch with an internal process indicator, sealed, then sterilized OR wrapped with an internal process indicator inside and secured on the outside with process indicator tape, then sterilized. Verify appropriate color change has been achieved in external process indicator immediately after removal from sterilizer then check internal process indicator before treatment. Refer to state regulations for any additional state requirements.

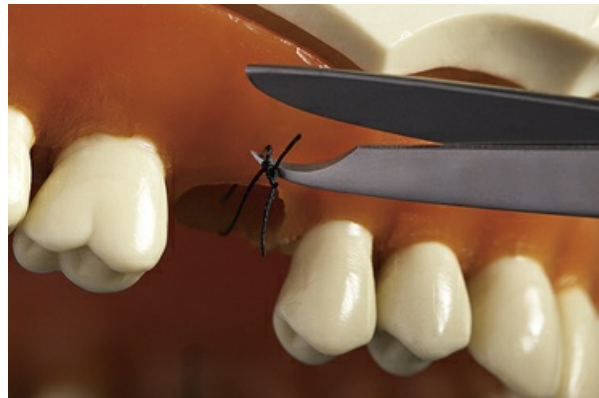

Tray Setup

Universal Surgical

Top Row (Left to Right)

Mouth mirror, explorer, cotton forceps (pliers), scalpel with #12 blade, periosteal elevator, surgical curette (Prichard), tissue forceps, hemostat, tissue scissors, mouth prop, needle holder, suture scissors, tongue and cheek retractor, disposable high-volume surgical evacuation tip, high-volume surgical evacuation tip

Bottom Row

Silk suture with needle in sterile package

Sterilization Notes

Refer to each picture for correct procedure for instrument sterilization or disposal of instrument or material. Refer to other chapters for additional instruments on this tray setup that are not included in this chapter.

Periodontal Instruments and Periodontal Surgical Instruments

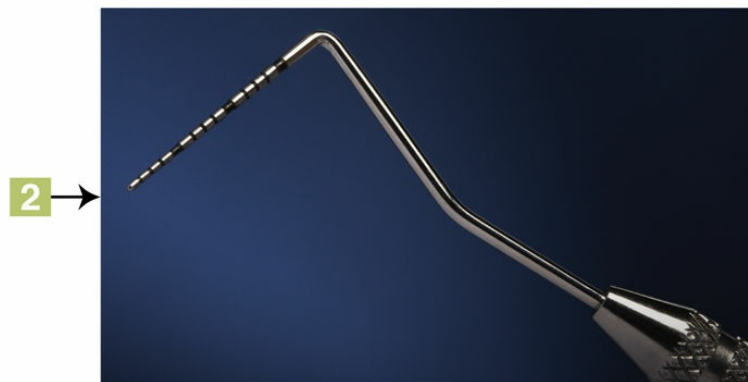

Instrument

Periodontal Probes

Function

To measure periodontal pocket depth in millimeter increments

Characteristics

Flat or rounded ends

Millimeter-increment markings vary for each style:

- Color coded—Black markings for millimeter measurements
- Other styles—Indentations in metal for millimeter measurement—each indentation represents a millimeter.
- Color-ended probe with black visible markings—Replaceable tip, different tip designs, plastic tip safe for implant probing

Double-ended style available with probe on one end and explorer on the other

Computerized probes available

Practice Note

Periodontal Probe is used on basic setup, dental hygiene, and periodontal tray setups.

Sterilization Notes

Periodontal Probes must be precleaned, either, placed in a sterilizing pouch with an internal process indicator, sealed, then sterilized OR wrapped with an internal process indicator inside and secured on the outside with process indicator tape, then sterilized. Verify appropriate color change has been achieved in external process indicator immediately after removal from sterilizer then check internal process indicator before treatment. Refer to state regulations for any additional state requirements.



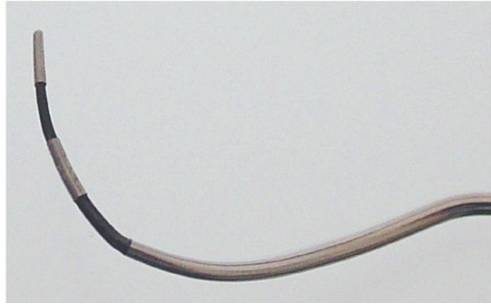

Instrument

Furcation Probe

Function

To measure horizontal and vertical pocket depth of multirrooted teeth in furcation areas

Characteristics

Flat or rounded ends

Single or double ended

Millimeter-increment markings vary for each style:

- Color coded—Black markings for millimeter measurements
- Other styles—Indentations in metal for millimeter measurements

Example

Nabors probe (color coded)

Practice Note

Furcation Probe is used on basic, dental hygiene, and periodontal tray setups.

Sterilization Notes

Furcation Probes must be precleaned, placed in sterilization pouch or bag and sealed or wrapped and secured with processing indicating tape, and then sterilized. An internal processing indicator should be included with each sterilization pouch or wrap. When an internal processing indicator is not visible, then an external processing indicator should be placed on the outside of the packaging. Indicators should be checked immediately upon removal from sterilizer to verify the appropriate color change has been achieved. Refer to state regulations for any additional state requirements.



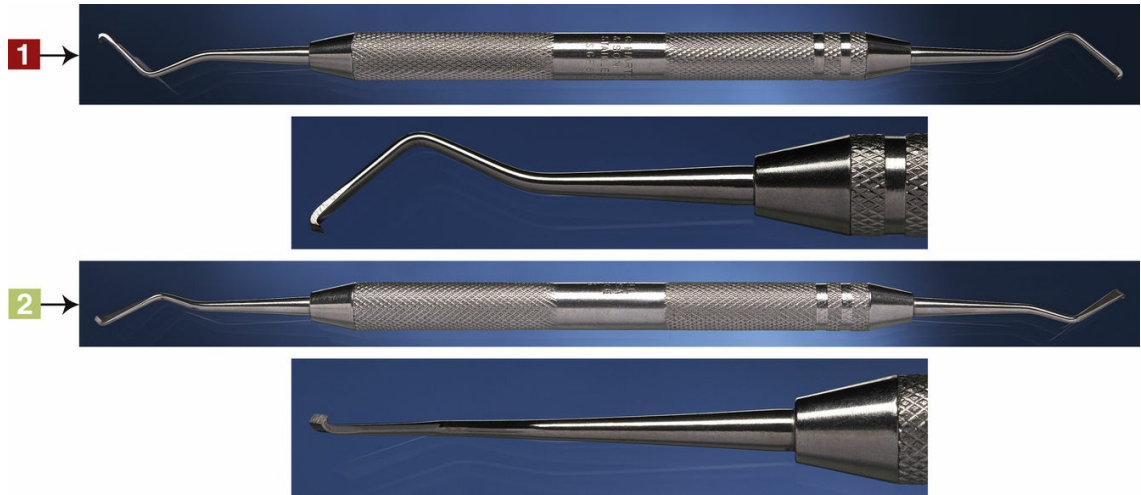

Instrument

Hoe Scaler—Mesial/Distal and Buccal/Lingual

Function

To remove subgingival and supragingival calculus

Characteristics

- Mesial/Distal Hoe
 - Buccal/Lingual Hoe scaler
- Used with pulling motion
Straight cutting edge
Single or double ended
Designed to function in anterior or posterior locations
- Anterior—Shorter, straighter shanks
 - Posterior—Longer, angled shanks

Practice Note

Mesial/Distal and Buccal/Lingual Hoe scalers, according to procedure performed, could be used on dental hygiene and periodontal tray setups.

Sterilization Notes

Mesial/Distal and Buccal/Lingual Hoes scalers must be precleaned, either, placed in a sterilizing pouch with an internal process indicator, sealed, then sterilized OR wrapped with an internal process indicator inside and secured on the outside with process indicator tape, then sterilized. Verify appropriate color change has been achieved in external process indicator immediately after removal from sterilizer then check internal process indicator before treatment. Refer to state regulations for any additional state requirements.

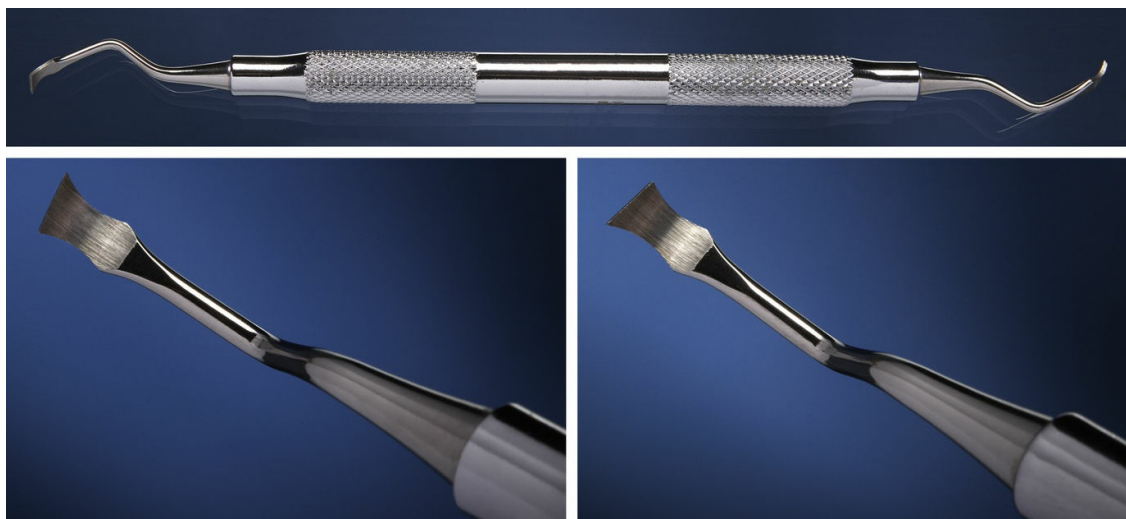

Instrument

Back-Action Hoe

Function

To remove bone adjacent to teeth without causing trauma

Characteristics

Double ended
Variety of sizes and shapes

Practice Note

Back-Action Hoe, according to procedure performed, could be used on dental hygiene and periodontal tray setups.

Sterilization Notes

Back-Action Hoe must be precleaned, either, placed in a sterilizing pouch with an internal process indicator, sealed, then sterilized OR wrapped with an internal process indicator inside and secured on the outside with process indicator tape, then sterilized. Verify appropriate color change has been achieved in external process indicator immediately after removal from sterilizer then check internal process indicator before treatment. Refer to state regulations for any additional state requirements.

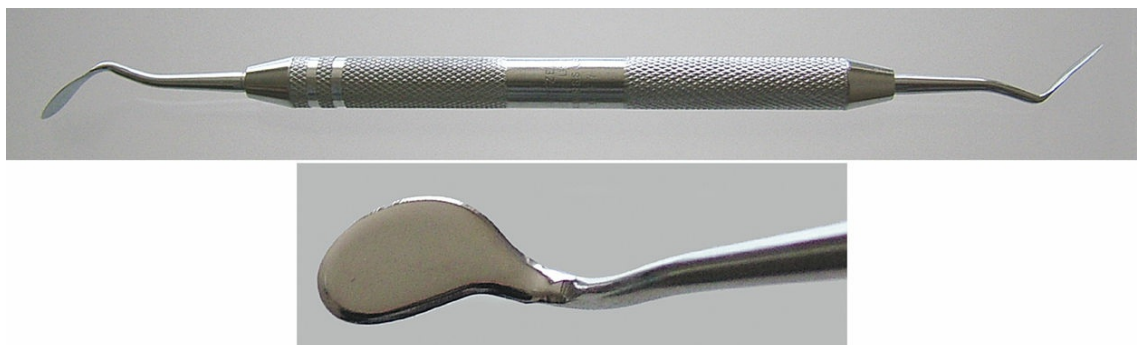
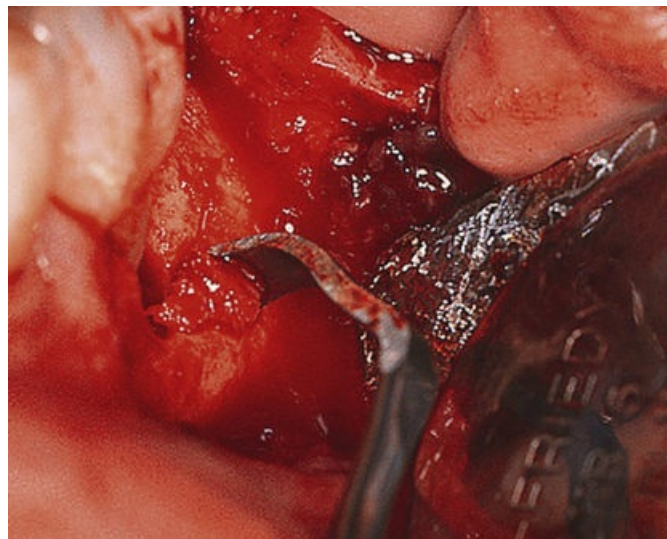

Instrument

Periodontal Knife—Kidney Shaped

Functions

To use for bevel incision for gingivectomy
To use for gingivoplasty

Characteristics

Variety of sizes and shapes
Named by designer: Kirkland, Goldman-Fox, Buck, Solt

Practice Note

Periodontal Knife—kidney shaped is used on periodontal surgical tray setups.

Sterilization Notes

Periodontal Knife—Kidney Shaped must be precleaned, either, placed in a sterilizing pouch with an internal process indicator, sealed, then sterilized OR wrapped with an internal process indicator inside and secured on the outside with process indicator tape, then sterilized. Verify appropriate color change has been achieved in external process indicator immediately after removal from sterilizer then check internal process indicator before treatment. Refer to state regulations for any additional state requirements.





Instrument

Interdental Knife—Spear Point

Functions

To use for interdental cutting of gingiva
To remove tissue

Characteristics

Blade angulated for easier use
Named by designer: Orban, Goldman-Fox, Buck, Sanders
Single or double ended
Range of sizes

Example

Buck 5/6

Practice Note

Interdental Knife—spear point is used on periodontal surgical tray setups.

Sterilization Notes

Interdental Knife—Spear Point must be precleaned, either, placed in a sterilizing pouch with an internal process indicator, sealed, then sterilized OR wrapped with an internal process indicator inside and secured on the outside with process indicator tape, then sterilized. Verify appropriate color change has been achieved in external process indicator immediately after removal from sterilizer then check internal process indicator before treatment. Refer to state regulations for any additional state requirements.

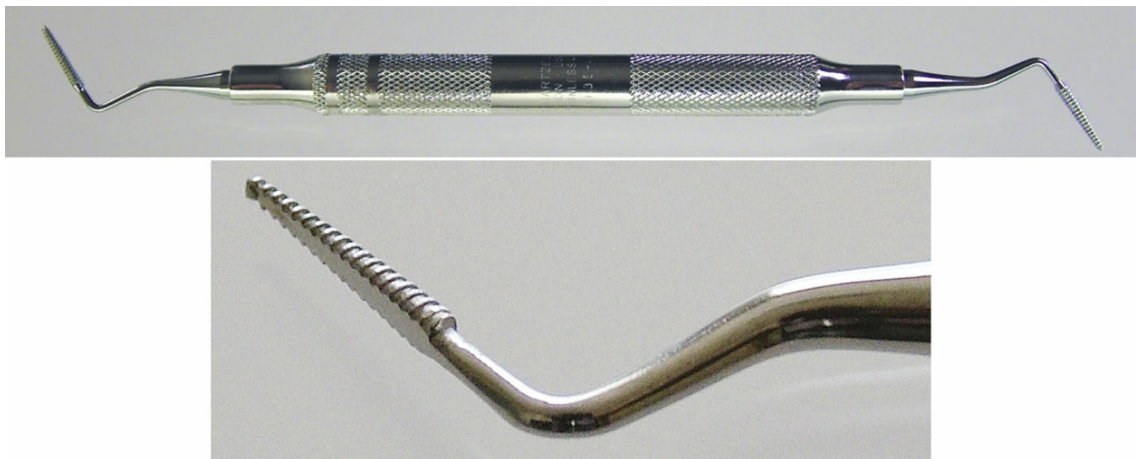

Instrument

Interdental File

Function

To crush and remove heavy deposits from subgingival and supragingival interproximal areas

Characteristics

Used with push or pull motion

Various angles—Curved, straight, mesial/distal, and buccal/lingual

Examples

Sugarman, Schluger, Buck

Range of sizes available

Practice Note

Interdental File is used on periodontal surgical tray setups.

Sterilization Notes

Interdental File must be precleaned, either, placed in a sterilizing pouch with an internal process indicator, sealed, then sterilized OR wrapped with an internal process indicator inside and secured on the outside with process indicator tape, then sterilized. Verify appropriate color change has been achieved in external process indicator immediately after removal from sterilizer then check internal process indicator before treatment. Refer to state regulations for any additional state requirements.



Tray Setup

Periodontal Surgical

Top Row—Left to Right

Mouth mirror, explorer, cotton forceps (pliers), periodontal probe, furcation probe, mesial/distal hoe, buccal/lingual hoe, back-action hoe, kidney-shaped periodontal knife, interproximal knife, bone file, tissue forceps, surgical curette, periosteal elevator

Bottom Row—Left to Right

Tissue scissors, scalpel with #12 blade, hemostat, silk sutures with needle, needle holder, suture scissors, cheek and tongue retractor (Minnesota), mouth prop, disposable high-volume surgical evacuation tip

Sterilization Notes

Refer to each picture for correct procedure for instrument sterilization or disposal of instrument or material. Refer to [Chapter 15](#) for complete instruments used in periodontal surgery. Also refer to other chapters for additional instruments on tray setup that are not included in this chapter.

Oral Surgery Extraction Instruments



Instrument

Straight Elevator

Functions

To loosen tooth from periodontal ligaments before extraction
To separate and lift tooth from socket

Characteristics

Single ended
Range of sizes available

Practice Note

Straight Elevator is used on surgical extraction tray setups.

Sterilization Notes

Straight Elevator must be precleaned, either, placed in a sterilizing pouch with an internal process indicator, sealed, then sterilized OR wrapped with an internal process indicator inside and secured on the outside with process indicator tape, then sterilized. Verify appropriate color change has been achieved in external process indicator immediately after removal from sterilizer then check internal process indicator before treatment. Refer to state regulations for any additional state requirements.



Instrument

Luxating Elevator

Functions

To cut periodontal ligaments before extraction
To rock tooth back and forth before extraction

Characteristics

Single ended
Sharp blade on working end
Blade is serrated
Range of sizes available

Practice Note

Luxating Elevator is used on surgical extraction tray setups.

Sterilization Notes

Luxating Elevator must be precleaned, either, placed in a sterilizing pouch with an internal process indicator, sealed, then sterilized OR wrapped with an internal process indicator inside and secured on the outside with process indicator tape, then sterilized. Verify appropriate color change has been achieved in external process indicator immediately after removal from sterilizer then check internal process indicator before treatment. Refer to state regulations for any additional state requirements.

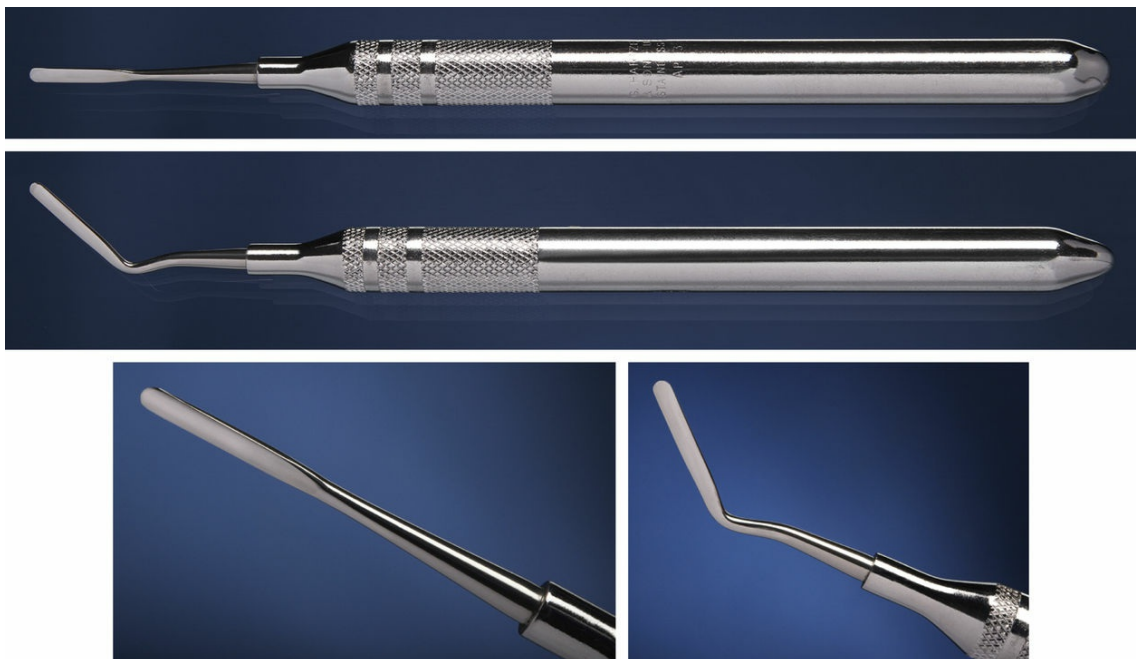

Instrument

Periotomes

Functions

To cut periodontal ligaments for atraumatic tooth extraction
To use when dental implant placement is indicated

Characteristics

Thin, sharp blades—Cause minimal damage to periodontal ligaments and surrounding alveolar bone
Straight or angled blades
Single or double ended
Range of sizes available
Some manufacturers make replaceable tip.

Practice Note

Periotomes are used on surgical extraction tray setups.

Sterilization Notes

Periotomes must be precleaned, either, placed in a sterilizing pouch with an internal process indicator, sealed, then sterilized OR wrapped with an internal process indicator inside and secured on the outside with process indicator tape, then sterilized. Verify appropriate color change has been achieved in external process indicator immediately after removal from sterilizer then check internal process indicator before treatment. Refer to state regulations for any additional state requirements.



Instrument

Root Elevators

Functions

To loosen root
To separate and lift root from socket
To use on posterior teeth

Characteristics

Single ended
Right and left pairs
Range of sizes available

Example

Cryer (commonly used type)

Practice Note

Root Elevators are used in surgical extraction tray setups.

Sterilization Notes

Root Elevators must be precleaned, either, placed in a sterilizing pouch with an internal process indicator, sealed, then sterilized OR wrapped with an internal process indicator inside and secured on the outside with process indicator tape, then sterilized. Verify appropriate color change has been achieved in external process indicator immediately after removal from sterilizer then check internal process indicator before treatment. Refer to state regulations for any additional state requirements.

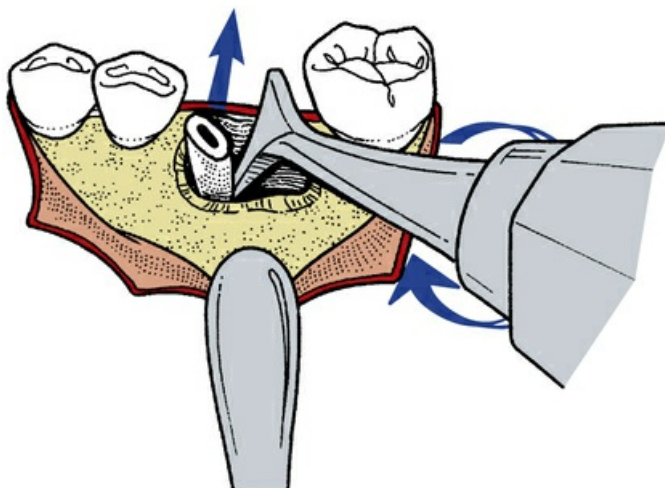



Instrument

T-Bar Elevators

Functions

To loosen tooth from periodontal ligaments before extraction
To separate tooth from alveolus
To use on posterior teeth

Characteristics

Single ended
Rounded or pointed
Right or left pairs
T-bar Elevators are available with different style handles
Range of sizes available

Practice Note

T-bar Elevators are used on surgical extraction tray setups.

Sterilization Notes

T-bar Elevators must be precleaned, either, placed in a sterilizing pouch with an internal process indicator, sealed, then sterilized OR wrapped with an internal process indicator inside and secured on the outside with process indicator tape, then sterilized. Verify appropriate color change has been achieved in external process indicator immediately after removal from sterilizer then check internal process indicator before treatment. Refer to state regulations for any additional state requirements.



Instrument

Root-Tip Elevators

Function

To lift and remove fragments of root

Characteristics

Single ended

Rounded or pointed

Working ends are serrated

Straight or right and left pairs

Practice Note

Root-tip Elevators are used on surgical extraction tray setups.

Sterilization Notes

Root-Tip Elevators must be precleaned, either, placed in a sterilizing pouch with an internal process indicator, sealed, then sterilized OR wrapped with an internal process indicator inside and secured on the outside with process indicator tape, then sterilized. Verify appropriate color change has been achieved in external process indicator immediately after removal from sterilizer then check internal process indicator before treatment. Refer to state regulations for any additional state requirements.

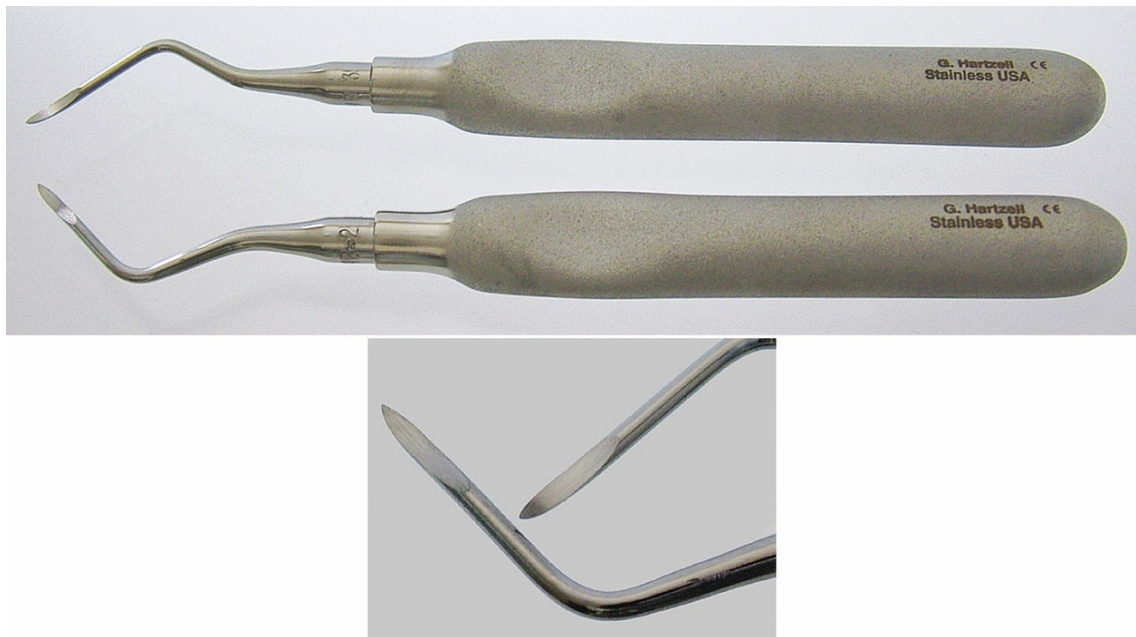

Instrument

Root-Tip Picks

Function

To lift and remove small root tips in difficult areas

Characteristics

Pointed at working end
Straight or right and left pairs

Practice Note

Root-tip Picks are used on surgical extraction tray setups.

Sterilization Notes

Root-Tip Picks must be precleaned, either, placed in a sterilizing pouch with an internal process indicator, sealed, then sterilized OR wrapped with an internal process indicator inside and secured on the outside with process indicator tape, then sterilized. Verify appropriate color change has been achieved in external process indicator immediately after removal from sterilizer then check internal process indicator before treatment. Refer to state regulations for any additional state requirements.



Instrument

Rongeurs

Functions

To trim and remove excess alveolar bone after extraction of teeth
To contour alveolar bone after single or multiple extractions

Characteristics

Variety of sizes and angles
Beaks have cutting edges

Practice Note

Rongeurs used on surgical extraction tray setups.

Sterilization Notes

Rongeurs must be precleaned open and unlocked, placed in an open and unlocked position either in a sterilizing pouch with an internal process indicator, sealed, then sterilized OR wrapped with an internal process indicator inside and secured on the outside with process indicator tape, then sterilized. Verify appropriate color change has been achieved in external process indicator immediately after removal from sterilizer then check internal process indicator before treatment. Refer to state regulations for any additional state requirements.



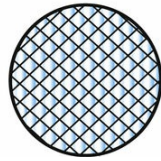
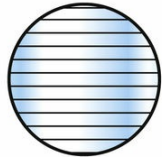
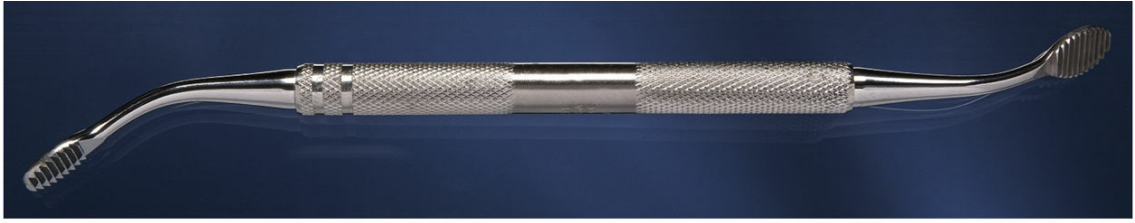

Instrument

Bone File

Function

To remove or smooth rough edges of alveolar bone

Characteristics

Used with push-pull motion
Straight-cut or crosscut cutting end
Variety of sizes, angles, and shapes

Practice Note

Bone File is used on surgical extraction tray setups.

Sterilization Notes

Bone File must be precleaned, either, placed in a sterilizing pouch with an internal process indicator, sealed, then sterilized OR wrapped with an internal process indicator inside and secured on the outside with process indicator tape, then sterilized. Verify appropriate color change has been achieved in external process indicator immediately after removal from sterilizer then check internal process indicator before treatment. Refer to state regulations for any additional state requirements.

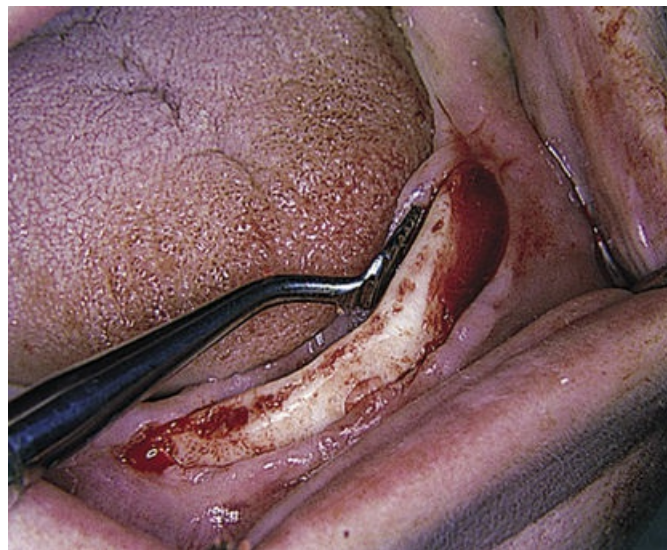



Instrument

Surgical Chisel

Functions

To split or section a tooth for easier removal by tapping on chisel with mallet
To reshape or contour alveolar bone

Characteristics

Single-bevel chisel—For contouring or removing alveolar bone
Bi-bevel chisel—For splitting teeth
Styles—Surgical chisel, bone splitter
Range of sizes available

Practice Note

Surgical Chisel is used on surgical extraction and other types of surgical procedure tray setups.

Sterilization Notes

Surgical Chisel must be precleaned, either, placed in a sterilizing pouch with an internal process indicator, sealed, then sterilized OR wrapped with an internal process indicator inside and secured on the outside with process indicator tape, then sterilized. Verify appropriate color change has been achieved in external process indicator immediately after removal from sterilizer then check internal process indicator before treatment. Refer to state regulations for any additional state requirements.



Instrument

Surgical Mallet

Functions

To use with bone chisel to section tooth for easier removal by tapping on chisel with surgical mallet
To use with bone chisel to reshape or contour alveolar bone

Characteristic

Range of sizes available

Practice Note

Surgical Mallet is used on surgical extraction and other types of surgical procedure tray setups.

Sterilization Notes

Surgical Mallet must be precleaned, either, placed in a sterilizing pouch with an internal process indicator, sealed, then sterilized OR wrapped with an internal process indicator inside and secured on the outside with process indicator tape, then sterilized. Verify appropriate color change has been achieved in external process indicator immediately after removal from sterilizer then check internal process indicator before treatment. Refer to state regulations for any additional state requirements.





Instrument

Universal Maxillary Forceps No. 10S

Function

To extract maxillary molars

Characteristic

Straight handle

Practice Note

Universal Maxillary Forceps No. 10S are used on surgical extraction tray setups.

Sterilization Notes

Universal Maxillary Forceps No. 10S must be precleaned open and unlocked, placed in an open and unlocked position either in a sterilizing pouch with an internal process indicator, sealed, then sterilized OR wrapped with an internal process indicator inside and secured on the outside with process indicator tape, then sterilized. Verify appropriate color change has been achieved in external process indicator immediately after removal from sterilizer then check internal process indicator before treatment. Refer to state regulations for any additional state requirements.





Instrument

Universal Mandibular Forceps No. 16

Function

To extract mandibular first and second molars

Characteristics

Straight handles or one curved handle
Referred to as cowhorn forceps

Practice Note

Universal Mandibular Forceps No. 16 (cowhorn) are used on surgical extraction tray setups.

Sterilization Notes

Universal Mandibular Forceps No. 16 must be precleaned open and unlocked, placed in an open and unlocked position either in a sterilizing pouch with an internal process indicator, sealed, then sterilized OR wrapped with an internal process indicator inside and secured on the outside with process indicator tape, then sterilized. Verify appropriate color change has been achieved in external process indicator immediately after removal from sterilizer then check internal process indicator before treatment. Refer to state regulations for any additional state requirements.





Instrument

Mandibular Forceps No. 17

Function

To extract bifurcated mandibular first or second molars

Characteristic

Straight handles

Practice Note

Mandibular Forceps No. 17 are used on surgical extraction tray setups.

Sterilization Notes

Mandibular Forceps No. 17 must be precleaned open and unlocked, placed in an open and unlocked position either in a sterilizing pouch with an internal process indicator, sealed, then sterilized OR wrapped with an internal process indicator inside and secured on the outside with process indicator tape, then sterilized. Verify appropriate color change has been achieved in external process indicator immediately after removal from sterilizer then check internal process indicator before treatment. Refer to state regulations for any additional state requirements.

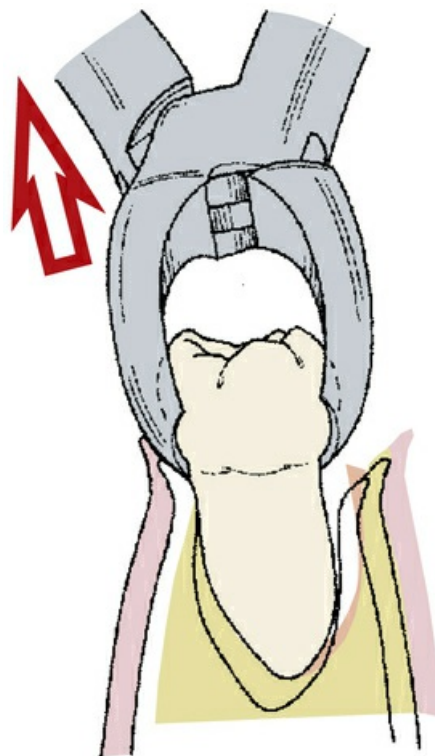



Instrument

Maxillary Right Forceps No. 88R

Function

To extract trifurcated maxillary right first or second molars

Characteristic

Right split beak—For engaging lingual root

Practice Note

Maxillary Right Forceps No. 88R are used on surgical extraction tray setups.

Sterilization Notes

Maxillary Right Forceps No. 88R must be precleaned open and unlocked, placed in an open and unlocked position either in a sterilizing pouch with an internal process indicator, sealed, then sterilized OR wrapped with an internal process indicator inside and secured on the outside with process indicator tape, then sterilized. Verify appropriate color change has been achieved in external process indicator immediately after removal from sterilizer then check internal process indicator before treatment. Refer to state regulations for any additional state requirements.





Instrument

Maxillary Left Forceps No. 88L

Function

To extract trifurcated maxillary left first or second molars

Characteristic

Left split beak—For engaging lingual root

Practice Note

Maxillary Left Forceps No. 88L are used on surgical extraction tray setups.

Sterilization Notes

Maxillary Left Forceps No. 88L must be precleaned open and unlocked, placed in an open and unlocked position either in a sterilizing pouch with an internal process indicator, sealed, then sterilized OR wrapped with an internal process indicator inside and secured on the outside with process indicator tape, then sterilized. Verify appropriate color change has been achieved in external process indicator immediately after removal from sterilizer then check internal process indicator before treatment. Refer to state regulations for any additional state requirements.





Instrument

Maxillary Universal Forceps—Cryer 150

Function

To extract maxillary centrals, laterals, cuspids, premolars, and roots

Characteristics

Straight handles or one curved handle

Practice Note

Maxillary Universal Forceps—Cryer 150 are used on surgical extraction tray setups.

Sterilization Notes

Maxillary Universal Forceps—Cryer 150 must be precleaned open and unlocked, placed in an open and unlocked position either in a sterilizing pouch with an internal process indicator, sealed, then sterilized OR wrapped with an internal process indicator inside and secured on the outside with process indicator tape, then sterilized. Verify appropriate color change has been achieved in external process indicator immediately after removal from sterilizer then check internal process indicator before treatment. Refer to state regulations for any additional state requirements.





Instrument

Mandibular Universal Forceps—Cryer 151

Function

To extract mandibular centrals, laterals, cuspids, premolars, and roots

Characteristics

Straight handles or one curved handle

Practice Note

Mandibular Universal Forceps—Cryer 151 are used on surgical extraction tray setups.

Sterilization Notes

Mandibular Universal Forceps—Cryer 151 must be precleaned open and unlocked, placed in an open and unlocked position either in a sterilizing pouch with an internal process indicator, sealed, then sterilized OR wrapped with an internal process indicator inside and secured on the outside with process indicator tape, then sterilized. Verify appropriate color change has been achieved in external process indicator immediately after removal from sterilizer then check internal process indicator before treatment. Refer to state regulations for any additional state requirements.





Instrument

Mandibular Anterior Forceps

Function

To extract mandibular anterior teeth

Characteristic

Serrated beaks

Practice Note

Mandibular Anterior Forceps are used on surgical extraction tray setups.

Sterilization Notes

Mandibular Anterior Forceps must be precleaned open and unlocked, placed in an open and unlocked position either in a sterilizing pouch with an internal process indicator, sealed, then sterilized OR wrapped with an internal process indicator inside and secured on the outside with process indicator tape, then sterilized. Verify appropriate color change has been achieved in external process indicator immediately after removal from sterilizer then check internal process indicator before treatment. Refer to state regulations for any additional state requirements.





Instrument

Maxillary Root Forceps

Function

To extract maxillary roots

Characteristics

Narrow, serrated beaks
Straight handles

Practice Note

Maxillary Root Forceps are used on surgical extraction tray setups.

Sterilization Notes

Maxillary Root Forceps must be precleaned open and unlocked, placed in an open and unlocked position either in a sterilizing pouch with an internal process indicator, sealed, then sterilized OR wrapped with an internal process indicator inside and secured on the outside with process indicator tape, then sterilized. Verify appropriate color change has been achieved in external process indicator immediately after removal from sterilizer then check internal process indicator before treatment. Refer to state regulations for any additional state requirements.



Instrument

Mandibular Root Forceps

Function

To extract mandibular roots

Characteristics

Narrow, serrated beaks
Straight handles

Practice Note

Mandibular Root Forceps are used on surgical extraction tray setups.

Sterilization Notes

Mandibular Root Forceps must be precleaned open and unlocked, placed in an open and unlocked position either in a sterilizing pouch with an internal process indicator, sealed, then sterilized OR wrapped with an internal process indicator inside and secured on the outside with process indicator tape, then sterilized. Verify appropriate color change has been achieved in external process indicator immediately after removal from sterilizer then check internal process indicator before treatment. Refer to state regulations for any additional state requirements.

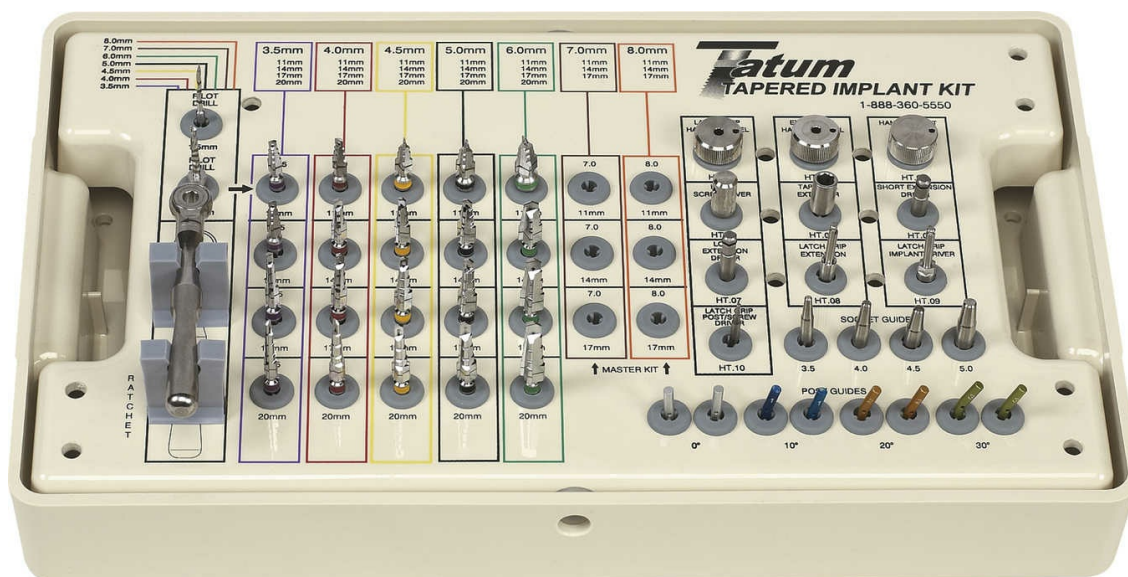

Instrument

Implant System

Function

To use for implant surgery

Characteristics

Components—Depth drills, thread formers, hand wrench, ratchet, ratchet adapter, hex driver
Many types of implant systems available

Practice Notes

Implant System is used on a surgical tray setup.
Sterile technique must be kept during procedure.

Sterilization Notes

Implant System must be precleaned, either, placed in a sterilizing pouch with an internal process indicator, sealed, then sterilized OR wrapped with an internal process indicator inside and secured on the outside with process indicator tape, then sterilized. Verify appropriate color change has been achieved in external process indicator immediately after removal from sterilizer then check internal process indicator before treatment. Refer to state regulations for any additional state requirements.

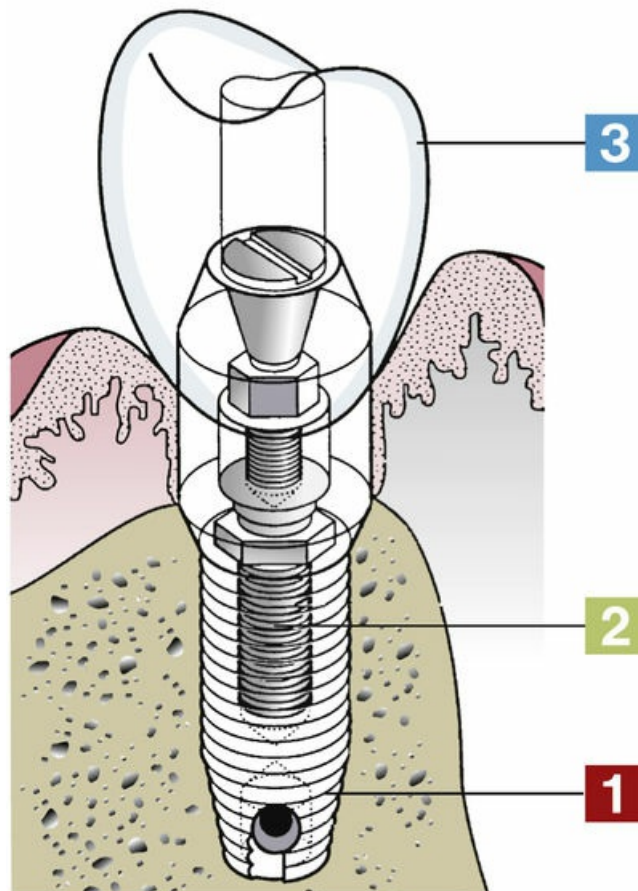

Instrument

Implant

Function

To use for implant surgery

Characteristics

Endosteal implant—An implant surgically embedded into the bone

Osseointegration—The attachment of healthy bone to a dental implant, also referred to as stably integrated

Two other types of implants—Subperiosteal and transosteal

Components:

- Implant fixture (titanium) embedded into bone; many styles of implants available
- Center screw
- Crown

Practice Notes

Implant is used on a surgical tray setup.

Sterile technique must be kept during procedure.

Sterilization Notes

Implant must be precleaned, either, placed in a sterilizing pouch with an internal process indicator, sealed, then sterilized OR wrapped with an internal process indicator inside and secured on the outside with process indicator tape, then sterilized. Verify appropriate color change has been achieved in external process indicator immediately after removal from sterilizer then check internal process indicator before treatment. Refer to state regulations for any additional state requirements. Use a biological indicator for every sterilizer load that contains an implantable device. Whenever possible, verify results before using the implantable device, according to the Centers for Disease Control and Prevention Guidelines for Infection Control in Dental Health-Care Settings—2003, Recommendations, Category IB. Strongly recommended for implementation and supported by experimental, clinical, or epidemiologic studies and a strong theoretical rationale.



Tray Setup

Extraction of Maxillary Right First Molar

Top Row (Left to Right)

Mouth mirror, explorer, cotton forceps, periosteal elevator, straight elevator, surgical curette, tissue forceps, hemostat, tissue scissors, mouth prop, needle holder, suture scissors, tongue and cheek retractor (Minnesota), disposable high-volume surgical evacuation tip, and maxillary right forceps no. 88R

Bottom Row

Silk suture with needle in sterile package

Sterilization Notes

Refer to each picture for correct procedure for instrument sterilization or disposal of instrument or material. Refer to [Chapter 15](#) to see additional instruments used in oral surgery extractions. Also refer to other chapters for additional instruments on this tray setup that are not included in this chapter.

For mandibular first or second molar extraction, the tray setup is identical to the tray setup for the extraction of a maxillary right first molar, except that a mandibular right forceps No. 17 is used in place of a maxillary right forceps No. 88R.



Tray Setup

Extraction of Impacted Mandibular Molar

Top Row (Left to Right)

Mouth mirror, explorer, cotton forceps (pliers), scalpel #12 with blade, periosteal elevator, straight elevator, right and left root-tip elevators, surgical curette, tissue forceps, rongeurs, bone file, surgical chisel, surgical mallet

Bottom Row (Left to Right)

Tissue scissors, hemostat, silk suture with needle in sterile package, needle holder, suture scissors, tongue and cheek retractor (Minnesota), surgical long-shank burs in bur holder, mouth prop, disposable high-volume surgical evacuation tip, universal mandibular forceps No. 16

Sterilization Notes

Refer to each picture for correct procedure for instrument sterilization or disposal of instrument or material. Refer to [Chapter 15](#) to see additional instruments used in oral surgery extractions. Also refer to other chapters for additional instruments on this tray setup that are not included in this chapter.



Tray Setup

Suture Removal

Left to Right

Mouth mirror, pigtail explorer, cotton forceps (pliers), suture scissors, saliva ejector, high-volume evacuator (HVE) tip, air/water syringe tip

Sterilization Notes

Refer to each picture for correct procedure for instrument sterilization or disposal of instrument or material. Refer to other chapters for instruments on this tray setup.

Sterilization and Protective Equipment



Instrument

Protective Gown

Function

To protect clothing, surgical scrubs, and skin during patient care and sterilization process to prevent contamination from blood and body substances

Characteristics

Disposable (pictured) or cloth (Cloth gowns must be made of polyester and cotton in accordance with state and federal regulations.)

Cuffed long sleeves

Closure at neckline

Moisture resistant (against contamination by liquids)

Many styles available

Practice Notes

All protective clothing should be removed before leaving the workplace.

Follow regulations within the state for standard precautions.

Sterilization Notes

Dispose of Protective Gown in garbage at the end of the day. If lab coat becomes visibly soiled during the work day, change to a new lab coat. Cloth lab coats must be laundered each day.

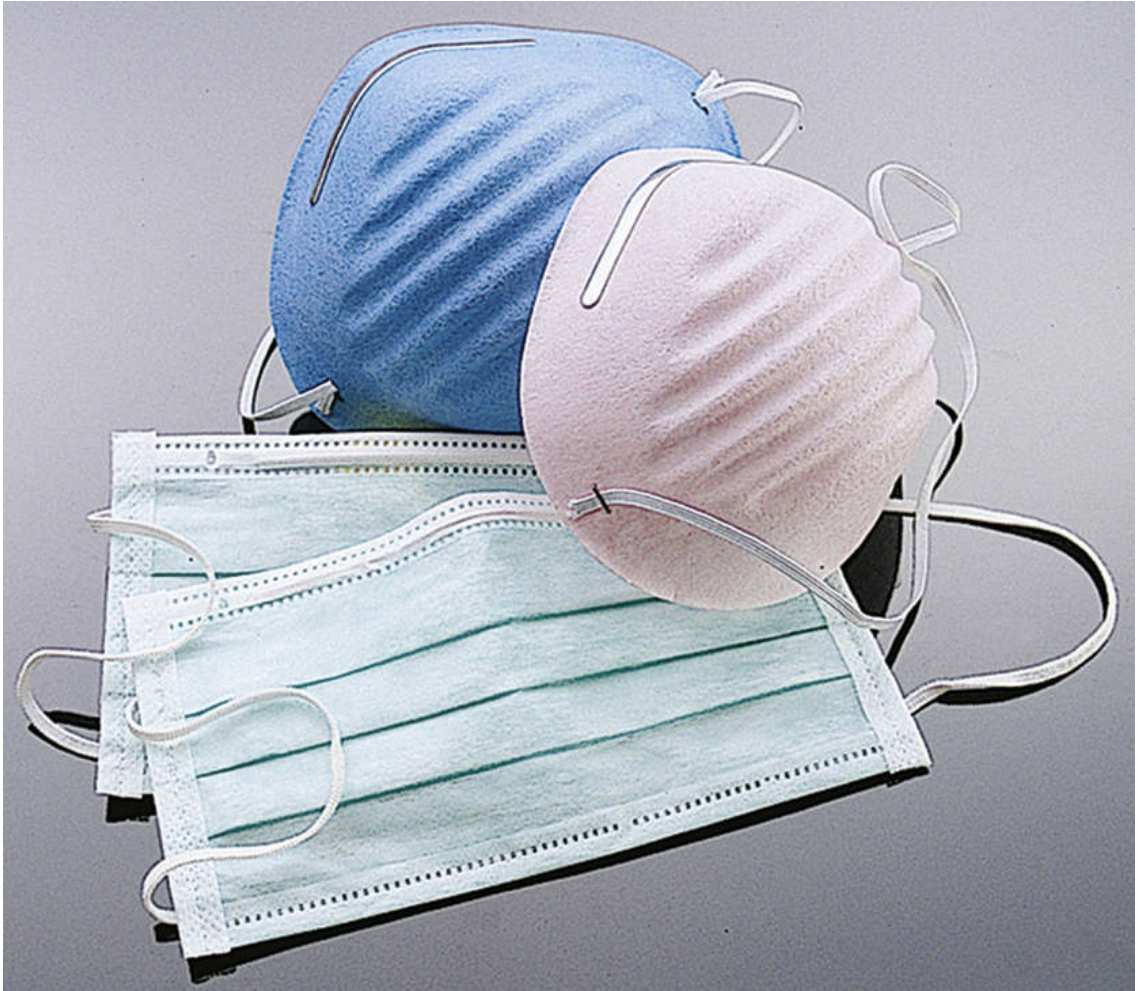

Instrument

Protective Mask

Functions

To protect against chemicals, airborne pathogens, bacteria, and viruses during processing of instruments for sterilization

To protect against airborne pathogens, bacteria, and viruses and against scrap filling material during all phases of patient treatment

Characteristics

Dome shaped or flat

Different levels of filtration

Practice Notes

Protective Mask must cover nose and mouth.

Protective Mask must be worn during dental procedures with a patient and during any exposure to dental material that is airborne.

Sterilization Notes

Protective Mask should be disposed of in the garbage. A new mask must be used with each patient.



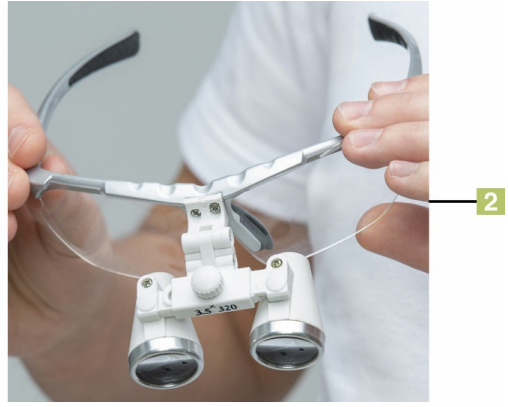

Instrument

Protective Glasses/Loupes

Functions

To protect against chemicals, airborne pathogens, bacteria, and viruses during processing of instruments for sterilization

To protect against airborne pathogens, bacteria, and viruses during patient care and against scrap-filling material during restorative and rinsing phases of patient treatment

To enhance (Loupes) depth-of-focus and field-of-view during treatment

Characteristics

Extend to sides, top, and bottom of eyes for complete protection

- Protective Glasses— Variety of styles available; some styles are larger to fit over prescription glasses.
- Loupes— Have different levels of magnification; may have a light source attached to the glasses for regular patient treatment, as well as, availability to change the light source for sensitive material (such as composite restorations).

Practice Notes

Facial shields available for eye protection (mask must be worn)

Protective glasses must be worn during dental procedures with a patient, sterilization, and during any exposure to dental material that is airborne.

Loupes allow a practitioner to maintain a more physiologic posture promoting ergonomically correct chair position during treatment.

Sterilization Notes

Protective glasses/loupes are disinfected between patients according to the manufacturer's recommendation. Refer to state regulations for any additional state requirements.





Instrument

Examination Gloves

Functions

- To wear during patient care
- To wear as a protective barrier
- To wear during treatment room disinfection

Characteristics

Latex (pictured), nitrile, or vinyl — Nonsterile and sterile gloves are available. Nonsterile gloves worn for most dental procedures; sterile gloves may be worn for surgical procedures. Examination Gloves should be worn over cuff of protective gown. Various sizes available

Practice Notes

Examination Gloves are single use only. Wash or sanitize hands before putting on gloves and after removing gloves. Must change if leaving patient care, or use overgloves (refer to pages 590 and 591). Replace worn or torn gloves immediately (along with washing hands or using hand sanitizer [follow state guidelines]). If procedure is long, change gloves every hour. Gloves must go over cuff of lab coat.

Sterilization Notes

Examination Gloves must be disposed of in the garbage.



Instrument

Overgloves

Functions

To wear over examination gloves when leaving the patient

To wear as a protective barrier over examination gloves so as not to cross-contaminate

Characteristics

Lightweight clear gloves

Not to be worn for dental procedures

Various sizes available

Practice Notes

New set of overgloves must be used for each patient. Keep overgloves in an uncontaminated area of the treatment room. Must be careful to not contaminate outside of overgloves when putting on over examination gloves.

Sterilization Notes

Overgloves must be disposed of in the garbage.



Instrument

Nitrile Utility Gloves

Functions

- To protect hands during processing of instruments for sterilization procedures
- To wear for preparation and handling of chemicals
- To disinfect operator
- To transport cassettes of tray setups to sterilization area from treatment area

Characteristics

- Chemical resistant
- Puncture resistant
- Ribbed for nonslip grip
- Range of sizes and colors
- Refer to state regulations on when utility gloves should be worn

Practice Note

Nitrile Utility Gloves should be kept in sterilization area of office.

Sterilization Notes

Nitrile Utility Gloves are disinfected after each use. Sterilize according to the manufacturer's recommendation and refer to local and state regulations.





Instrument

Cassette

Functions

To use for instruments as tray setup
To use for instrument sterilization

Characteristics

Available in metal or resin
Color coded
Range of sizes

Practice Notes

Instruments in the cassette may be cleaned in an ultrasonic cleaner and then wrapped and sterilized.
Color coding aids in the identification of cassettes and tray setups.

Sterilization Notes

Cassette with instruments must be precleaned, either, placed in a sterilizing pouch with an internal process indicator, sealed, then sterilized OR wrapped with an internal process indicator inside and secured on the outside with process indicator tape, then sterilized. Verify appropriate color change has been achieved in external process indicator immediately after removal from sterilizer then check internal process indicator before treatment. Refer to state regulations for any additional state requirements.



Instrument

Color-Coding System for Instruments

Function

To color code instruments for organization and identification of tray setups

Characteristic

Variety of colors—Color coding coordinates with color cassettes

Practice Note

The Color-Coding System makes it easier to identify tray setups and instruments within the tray setup.

Sterilization Notes

Color-Coded Instruments must be precleaned, either, placed in a sterilizing pouch with an internal process indicator, sealed, then sterilized OR wrapped with an internal process indicator inside and secured on the outside with process indicator tape, then sterilized. Verify appropriate color change has been achieved in external process indicator immediately after removal from sterilizer then check internal process indicator before treatment. Refer to state regulations for any additional state requirements.



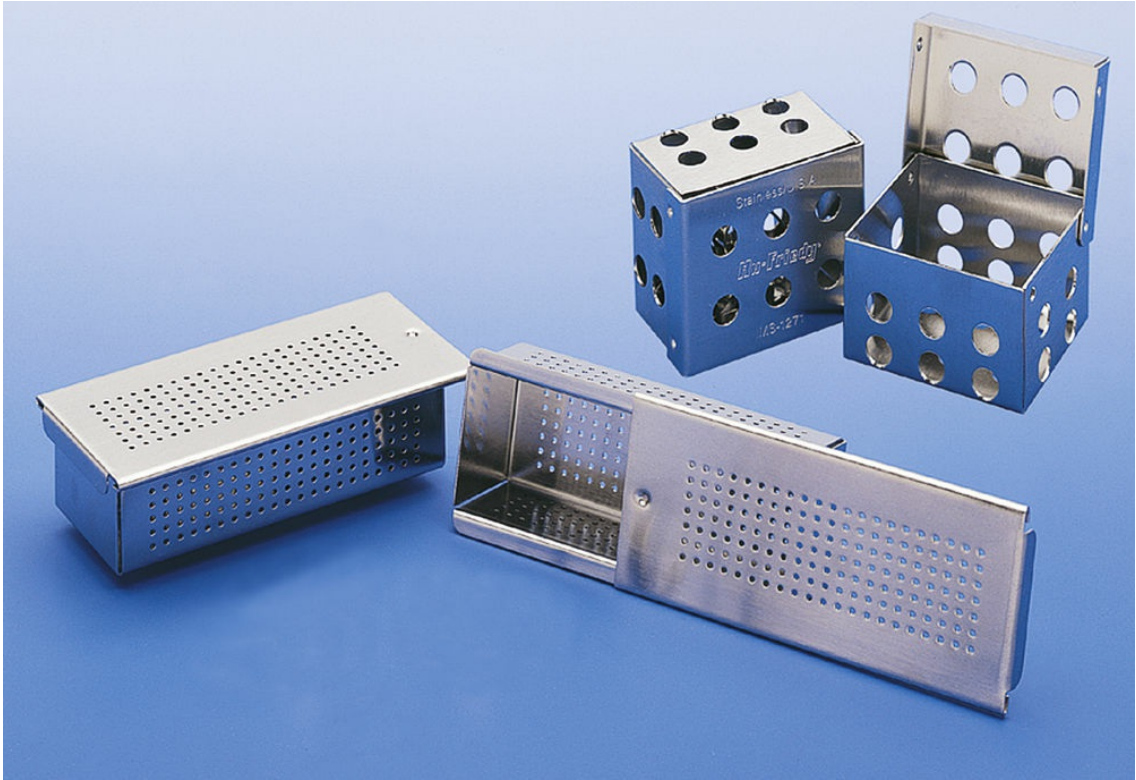

Instrument

Parts Box for Sterilization

Function

To use for sterilization of small items

Examples

Burs, dental dam clamps

Characteristic

Range of sizes to accommodate sterilization needs

Practice Note

Parts Box helps hold and organize small items for tray setups.

Sterilization Notes

Parts Box must be precleaned, either, placed in a sterilizing pouch with an internal process indicator, sealed, then sterilized OR wrapped with an internal process indicator inside and secured on the outside with process indicator tape, then sterilized. Verify appropriate color change has been achieved in external process indicator immediately after removal from sterilizer then check internal process indicator before treatment. Refer to state regulations for any additional state requirements.



Instrument

Cassette Wrap

Functions

- To use to wrap cassette during sterilization
- To store cassette in wrapping after sterilization
- To use for tray cover during dental procedure

Characteristic

Range of sizes—To accommodate cassettes

Practice Note

Cassettes should be kept in sterile wrap until the patient is seated. Refer to local and state regulations.

Sterilization Notes

All instruments or cassettes must be precleaned, either, placed in a sterilizing pouch with an internal process indicator, sealed, then sterilized OR wrapped with an internal process indicator inside and secured on the outside with process indicator tape, then sterilized. Verify appropriate color change has been achieved in external process indicator immediately after removal from sterilizer then write date and sterilizer used on wrap. Check internal process indicator before treatment. Refer to state regulations for any additional state requirements.



Instrument

Sterilization Pouches

Function

To be used for sterilization of instruments and cassettes

Characteristic

Pouches have range of sizes to accommodate all sizes of instruments and cassettes.

Available with Self Seal Pouches

Available with indicator strip on pouch

- Indicator strip changed color after sterilization
- Indicator strip color before sterilization
- Cassette with indicator tape on outside of pouch

Practice Note

Instruments should be kept in the pouches until the patient is seated. Refer to state regulations.

Sterilization Notes

All instruments must be precleaned placed in a sterilization pouch with an internal process indicator, sealed, then sterilized. Verify appropriate color change has been achieved in external process indicator immediately after removal from sterilizer then write date and sterilizer used on pouch. Check internal process indicator before treatment. Refer to state regulations for any additional state requirements.



Instrument

Indicator Tape and Dispensing Unit

Functions

To secure wrap on outside of cassette

To use outside cassettes or sterilization pouches to indicate exposure of instruments to a certain temperature—Color will change on the tape.

Characteristics

Available in preprinted tray setup procedures-refer to page 602 and 603.

Available with color coding

Available blank for labeling tape with procedure and/or instrument content

Practice Note

Instruments should be kept in the pouches until the patient is seated. Refer to state regulations.

Sterilization Notes

When Indicator Tape is placed outside a cassette, the strips change color with exposure to temperature of the sterilization process; they do not determine the actual sterilization. Refer to sterilization monitoring. If the indicator tape does not change color the pouch or wrap must be resterilized.



Instrument

Biological Monitors for Sterilizers

Function

To confirm efficacy of sterilization, documentation of results is recorded in office sterilization log

Characteristic

Many systems available

Practice Note

Biological Monitor Testing device is placed in the sterilizer for one cycle of instruments. It is then mailed to the manufacturer, which mails back the findings. The results are logged in the office sterilization records.

Sterilization Notes

The Centers for Disease Control and Prevention, the American Dental Association, and the Office Safety and Asepsis Procedures Research Foundation recommend at least weekly testing of each sterilizer in the office. Local and state requirements may be different.



Instrument

Sterilization Spore Check—In Office

Function

To monitor and confirm the effectiveness of steam sterilizers

Characteristics

- Record book
- Self-contained biological indicator
- Dry block incubator

Practice Note

A vial with the solution is marked and placed in a sterilization pouch, and the sterilization cycle is processed. After the cycle is complete, follow the directions; then place vial in incubator. Results will occur in 24 hours. Record results.

Sterilization Notes

Steam sterilizers should be checked for effectiveness every week. Every load of implants should be monitored for effectiveness when possible with each implant before each implant procedure.



Instrument

Sharps Container

Function

To serve as storage receptacle for used needles, old burs, scalpel blades, orthodontic wires, endodontic files, and all other disposable sharp items used during dental procedures

Characteristics

Must be puncture resistant
Must be labeled "Biohazard"
Must have a reclosable top

Practice Note

Sharps containers must be disposed of according to local, state, and federal regulations and by an Environmental Protection Agency regulatory disposal company. Required paperwork must be kept according to state and federal regulations.

Sterilization Notes

Refer to state and local regulations on the type of glove (utility and patient glove) to handle sharps that are disposed in the Sharps Container.



Instrument

Ultrasonic Cleaning Unit

Function

To remove debris and bioburden from instruments

Characteristic

Reduces risk of exposure to pathogens during the cleaning stage of the sterilization process

Practice Notes

Tank is filled with antimicrobial or general all-purpose solution specially designed for the ultrasonic unit. Fill and drain solution daily.

Debris is removed by mechanical means; sound waves create tiny bubbles that cause inward collapse (implosion) and removal of material. Lid must be closed during operation of unit.

Available in some units are racks for cassettes.

Sterilization Notes

After cleaning the instruments in the ultrasonic cleaning unit, instruments must be rinsed and either be placed in a sterilizing pouch with an internal process indicator, sealed, then sterilized OR wrapped with an internal process indicator inside and secured on the outside with process indicator tape, then sterilized. Verify appropriate color change has been achieved in external process indicator immediately after removal from sterilizer then check internal process indicator before treatment. Refer to state regulations for any additional state requirements.

For precleaning instruments *Guidelines for Infection Control in Dental Health-Care Settings—2003* states “that the use of automated cleaning equipment such as ultrasonic cleaner or washer-disinfector is safer than hand scrubbing instruments prior to continuing the sterilization process even though hand washing is acceptable.”



Instrument

Sterilizer—Autoclave (Saturated Steam)

Function

To kill all microbes, viruses, bacteria, and fungi, thereby sterilizing instruments

Characteristics

Uses steam under pressure—15 pounds per square inch (psi) at 250°F for 20 minutes

Shelves and racks are available for cassettes

Various styles and manufacturers

Range of sizes

Practice Notes

Refer to federal, state, and manufacturer's sterilization techniques as well as manufacturer's maintenance requirements.

Sterilization Notes

The Centers for Disease Control and Prevention, the American Dental Association, and the Office Safety and Asepsis Procedures Research Foundation recommend at least weekly testing of Sterilizers. Local and state requirements may be different. Refer to pages 606 and 607 for Biological Monitors for Sterilization.



Instrument

Statim G4 Cassette Autoclave

Functions

To kill all microbes, viruses, bacteria, and fungi
To sterilize instruments and handpieces

Characteristics

Statim 2000 G4 cycle times: 6 minutes unwrapped, 14 minutes wrapped
Statim 5000 G4 cycle times: 9 minutes unwrapped, 17.5 minutes wrapped
Uses fresh steam-distilled water with every cycle
Uses Dri-Tec drying system for fast dry loads
Readout Screen available for each cycle

Practice Note

Refer to federal, state, and manufacturer's sterilization techniques as well as manufacturer's maintenance requirements.

Sterilization Notes

The Centers for Disease Control and Prevention, the American Dental Association, and the Office Safety and Asepsis Procedures Research Foundation recommend at least weekly testing of sterilizers. Local and state requirements may be different. Refer to pages [606](#) and [607](#) for Biological Monitors for Sterilization.



Instrument

Sterilizer—Dry Heat (Static Air)

Function

To kill all microbes, viruses, bacteria, and fungi, thereby sterilizing instruments

Characteristics

Oven-type sterilizer
320°F for 60 to 120 minutes
Shelves available for cassettes
Various styles and manufacturers
Range of sizes

Practice Notes

Packaging and wrapped material must be able to withstand high temperatures.
Door cannot be opened during sterilization cycle.
Items cannot be layered or stacked but should be placed on their edges.

Sterilization Notes

The Centers for Disease Control and Prevention, the American Dental Association, and the Office Safety and Asepsis Procedures Research Foundation recommend at least weekly testing of Sterilizers. Local and state requirements may be different. Refer to pages [606](#) and [607](#) for Biological Monitors for Sterilization.



Instrument

Sterilizer—Dry Heat (Rapid Heat Transfer)

Function

To kill all microbes, viruses, bacteria, and fungi, thereby sterilizing instruments

Characteristics

Forced air-type sterilizer
375°F for 12 minutes (wrapped)
375°F for 6 minutes (unwrapped)
Instruments placed in preheated chamber
Various styles and manufacturers
Range of sizes

Practice Notes

Packaging and wrapped material must be able to withstand high temperatures.
Door cannot be opened during sterilization cycle.

Sterilization Notes

The Centers for Disease Control and Prevention, the American Dental Association, and the Office Safety and Asepsis Procedures Research Foundation recommend at least weekly testing of Sterilizers. Local and state requirements may be different. Refer to pages [606](#) and [607](#) for Biological Monitors for Sterilization.

Dental Materials Equipment

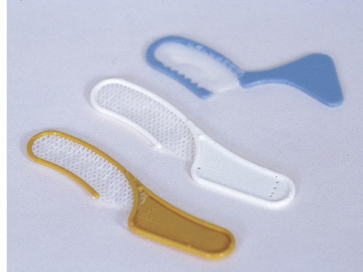

Instrument

Flexible Rubber Bowl

Functions

To mix material, usually a powder and a liquid

To mix impression material and irreversible hydrocolloid for study models, opposing models, bleaching trays, night guards, mouth guards, orthodontic appliances, or custom trays for removable appliances

To mix laboratory plaster, stone, and die stone for models

Characteristic

Bowl is flexible to manipulate material.

Practice Note

Flexible Rubber Bowl is used with the alginate spatula.

Sterilization Notes

Preclean and disinfect Flexible Rubber Bowl before and after each use according to the manufacturer's recommendation.



Instrument

Flexible Alginate (Irreversible Hydrocolloid) Spatula

Functions

- To mix powder and a liquid in a flexible bowl
- To mix impression material such as irreversible hydrocolloid (alginate)
- To mix laboratory plaster, stone, and die stone for models

Characteristic

Spatula is flexible to manipulate material.

Practice Note

Flexible Alginate Spatula is used with the flexible rubber bowl.

Sterilization Notes

Preclean and disinfect Flexible Alginate Spatula before and after each use according to manufacturer's recommendation.





Instrument

Disposable Plastic Perforated Full Arch Impression Trays

Function

To use for taking impressions with many types of impression material

Example

Irreversible hydrocolloid (alginate), crown, and bridge impression material

Characteristics

- Maxillary perforated tray
- Mandibular perforated tray

Perforated trays allow material to push through the tray, creating a mechanical lock that keeps the material in place.

Range of sizes

Practice Notes

Disposable Plastic Perforated trays are used for many types of dental procedures involving taking impressions.

Impressions must be rinsed then disinfected before pouring up impressions.

Sterilization Notes

Disposable Plastic Perforated Full Arch Impression Trays should be disposed of in the garbage. Single use only.



Instrument

Metal Perforated Full Arch Impression Trays

Function

To use for taking impressions with many types of impression material.

Example

Irreversible hydrocolloid (alginate), crown, and bridge impression material

Characteristics

- Maxillary Metal Perforated Tray
- Mandibular Metal Perforated Tray

Perforated trays allow material to push through the tray, creating a mechanical lock that keeps the material in place.

Range of sizes

Practice Notes

Metal Perforated Full Arch Impression Trays are used for many types of dental procedures involving taking impressions.

Impression trays must be rinsed then disinfected before pouring up impressions.

Sterilization Notes

Metal Perforated Full Arch Impression Trays must be precleaned, either, placed in a sterilizing pouch with an internal process indicator, sealed, then sterilized OR wrapped with an internal process indicator inside and secured on the outside with process indicator tape, then sterilized. Verify appropriate color change has been achieved in external process indicator immediately after removal from sterilizer then check internal process indicator before treatment. Refer to state regulations for any additional state requirements.





Instrument

Disposable Plastic Perforated Quadrant and Anterior Impression Trays

Functions

To use for taking impressions with many types of impression material
To use for taking a quadrant or anterior portion of the mouth

Characteristics

- Section tray for anterior maxillary or mandibular perforated tray
- Maxillary left or mandibular right perforated tray
- Maxillary right or mandibular left perforated tray

Perforated trays allow material to push through the tray, creating a mechanical lock that keeps the material in place.

Range of sizes

Metal quadrant and anterior trays also available. Refer to sterilization notes below.

Practice Notes

Disposable Plastic Perforated Quadrant and Anterior Impression Trays are used for many types of dental procedures involving taking impressions.

Impressions must be rinsed then disinfected before pouring up impressions.

Sterilization Notes

Disposable Plastic Perforated Quadrant And Anterior Impression Trays should be disposed of in the garbage. Single use only.



Instrument

Alginator

Function

To mix alginate, irreversible hydrocolloid automatically

Characteristics

Flexible bowl attaches to alginator

Low and high buttons allow bowl to rotate, mixing the alginate and water together.

Spatula pressing the material against the bowl along with the rotation of the bowl results in the material being a smooth consistency.

Practice Notes

Alginator is used for many dental procedures involving taking an alginate impression.

Impressions must be cleaned and disinfected before pouring up impressions.

Sterilization Notes

Alginator case must be precleaned, sprayed with a disinfectant to wipe clean the surface, then, sprayed a second time to disinfect according the manufacturers guidelines with an approved TB/hospital wipe or spray. The Flexible Alginate Bowl must be precleaned thoroughly after removing alginate from the bowl, then, sprayed a second time to disinfect with an approved TB/hospital wipe or spray. Switch on the unit when wiping the bowl to assure thorough coverage. Refer to state regulations for any additional state requirements.



Instrument

Triple Tray (Disposable)

Functions

To use for taking final impressions for crown and bridge restorations, opposing teeth, and bite registration with one impression

To use in the mouth, taking maxillary and mandibular simultaneously

To use with many types of impression material

Characteristics

Trays have a ledge on the side to hold sufficient amount of material for the impression.

Trays have mesh-type material in the middle of the tray to hold material in place.

Trays available:

- Quadrant used for maxillary right/left or mandibular right/left
- Maxillary left or mandibular right perforated tray
- Anterior maxillary or mandibular perforated tray

Practice Note

Triple Trays are used for many types of dental procedures.

Impressions must be rinsed then disinfected before pouring up impressions.

Sterilization Notes

Triple Trays should be disposed of in the garbage. Single use only.



Instrument

Mixing Gun for Dental Impression Material

Functions

- To mix polyvinylsiloxane, polysulfide, and polyether material for final impression
- To mix base and catalyst for impression tray
- To mix wash material for the syringe
- To mix material for bite registration and temporary crowns

Characteristics

- Mixing gun
 - Material used in gun
- Manufacturers have different-style guns to accommodate their material. A different technique for the tray material is to mix a putty material that is a base and a catalyst.

Practice Notes

- A tube with the base and catalyst is inserted into the mixing gun with a mixing rod attached. Pressure is placed on the trigger of the gun, and the material extrudes from the tubes into the mixing rod and onto the impression tray or into the tube of the syringe. Tray material and wash (syringe) material are different.

Sterilization Notes

Use overgloves to handle Mixing Gun or preclean and disinfect after each use according to the manufacturer's recommendation. Mixing rod tips should be disposed of in the garbage. Single use only.



Instrument

Automixer

Functions

To automatically mix impression material

To mix base and catalyst for polyvinylsiloxane and polyether material

To place material after dispensing from automixer into impression trays for final impressions

Characteristics

Different styles of automixers available

Must attach mixing tips

Practice Notes

A wash material (delivered from a syringe) is placed on the prepared tooth by the operator before the tray with the impression material is placed in the patient's mouth.

Polyvinylsiloxane can also be mixed manually.

Sterilization Notes

Use overgloves to handle Automixer or preclean and disinfect after each use according to the manufacturer's recommendation.



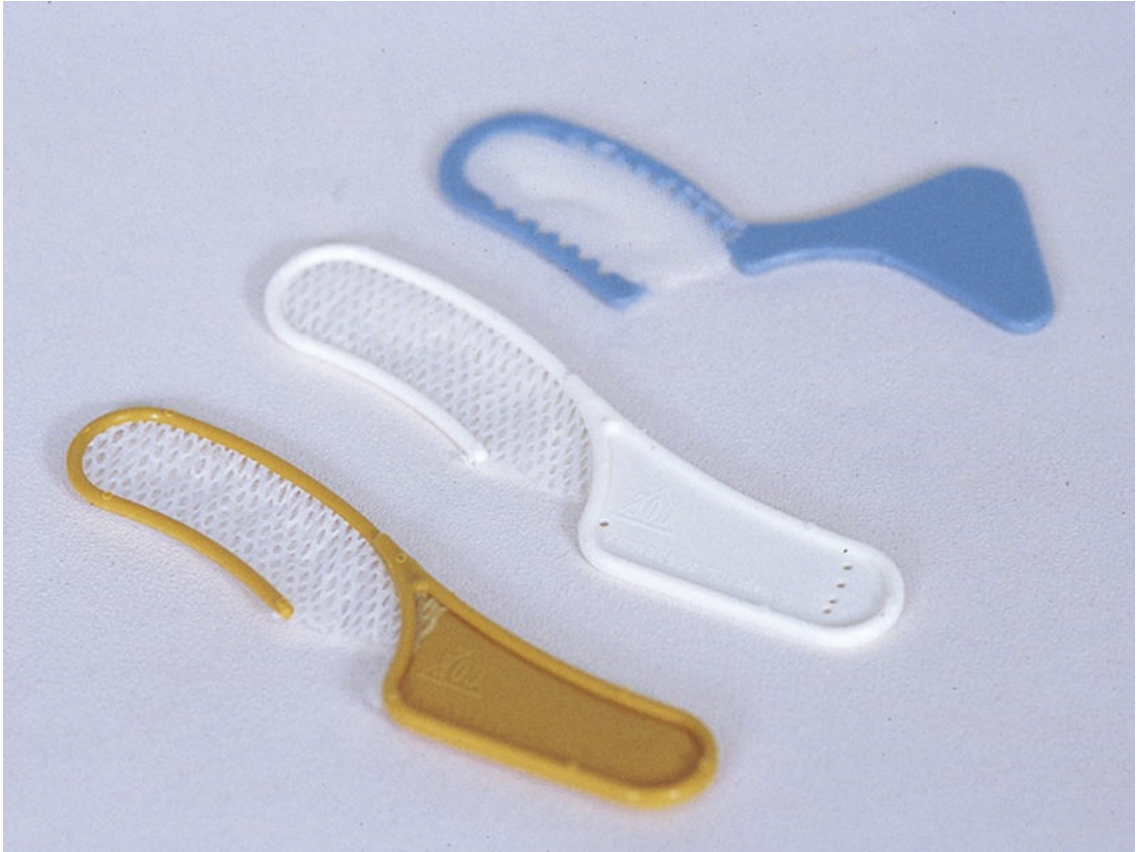

Instrument

Bite Registration Tray

Functions

To use for taking bite registration for crown and bridge procedures
To use in the mouth, taking maxillary and mandibular simultaneously
To use with many types of bite registration material

Characteristics

Trays have mesh-type material in the middle of the tray to hold material in place.
Range of sizes
Trays can be used in right or left quadrant.
Anterior section bite registration tray is also available.

Practice Notes

Bite Registration Trays is used with crown and bridge tray setup.
Mixing guns may be used to mix material.
Bite registration tray should be rinsed then disinfected before sending to laboratory.

Sterilization Notes

Bite Registration Trays should be disposed of in the garbage. Single use only.



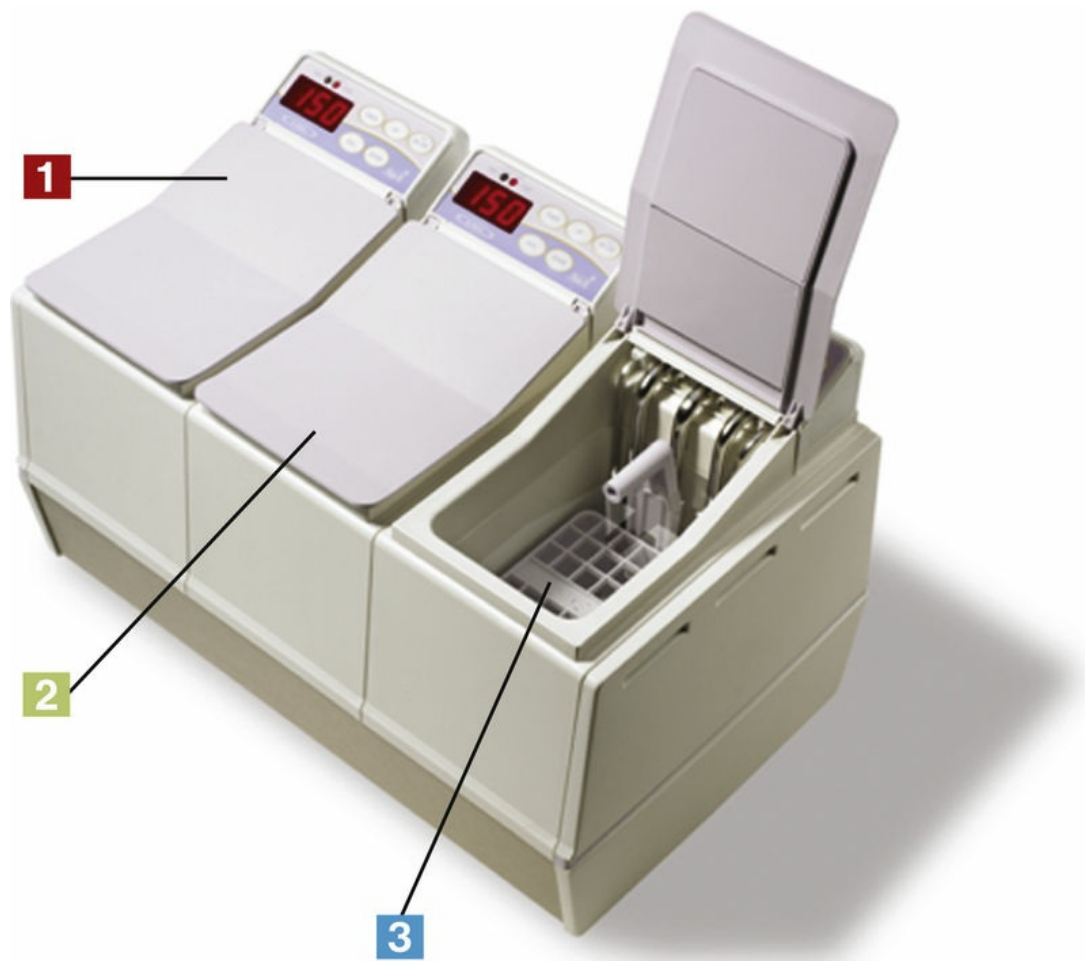

Instrument

Reversible Hydrocolloid Unit

Function

To boil reversible hydrocolloid, store, and temper material for final impressions

Characteristics

Hydrocolloid unit has three baths:

- Liquefying the semisolid material at 212°F (100°C)
- Storage bath that cools the material and keeps it ready for impressions at 150°F (65.5°C)
- Tempering bath holds the filled impression tray for 5 minutes before it is placed in the patient's mouth at 110°F (44°C).

Tubes of the material are for the impression tray.

Small cylinders are for the wash material and are used in syringes for operator to place around tooth before impression is taken.

Practice Note

Reversible hydrocolloid water-cooled impression trays need to be used for this type of impression material.

Sterilization Notes

Preclean and disinfect Reversible Hydrocolloid Unit, if contaminated, before and after each use according to the manufacturer's recommendation.

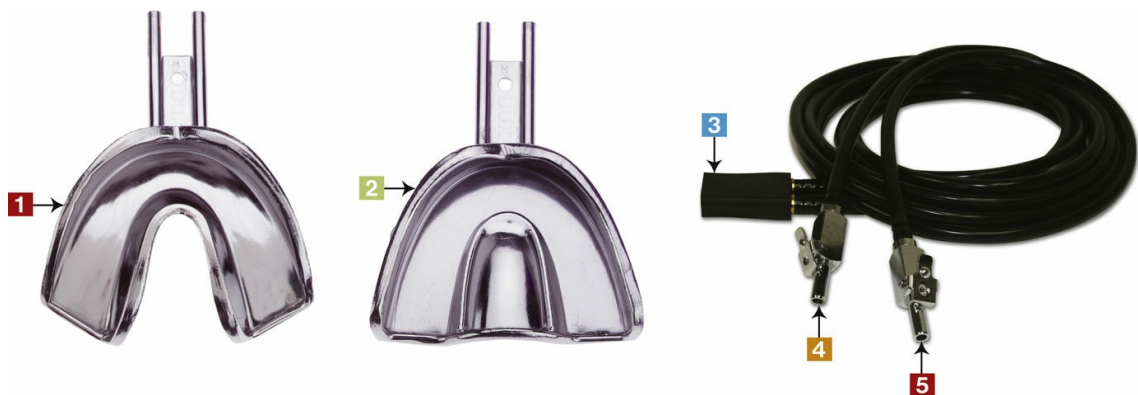

Instrument

Reversible Hydrocolloid Water-Cooled Impression Trays and Hose

Function

To take impression with reversible hydrocolloid

Characteristics

- Mandibular water-cooled tray
- Maxillary water-cooled tray
- Attaches to tray
- Attaches to water source on dental unit
- Attaches to vacuum system of dental unit

A hose attaches to the tray on one end; the other end attaches to a water source and a vacuum for the water.

The water runs inside the tray, which cools and sets the material once in the patient's mouth.

Practice Note

Important to connect all parts of the hose before turning on the water source

Impression must be rinsed then disinfected before sending to lab

Sterilization Notes

Irreversible Hydrocolloid Water-cooled Impression Trays must be precleaned, either, placed in a sterilizing pouch with an internal process indicator, sealed, then sterilized OR wrapped with an internal process indicator inside and secured on the outside with process indicator tape, then sterilized. Verify appropriate color change has been achieved in external process indicator immediately after removal from sterilizer then check internal process indicator before treatment. Refer to state regulations for any additional state requirements. Hose must be precleaned and disinfected according to the manufacturer's recommendation.

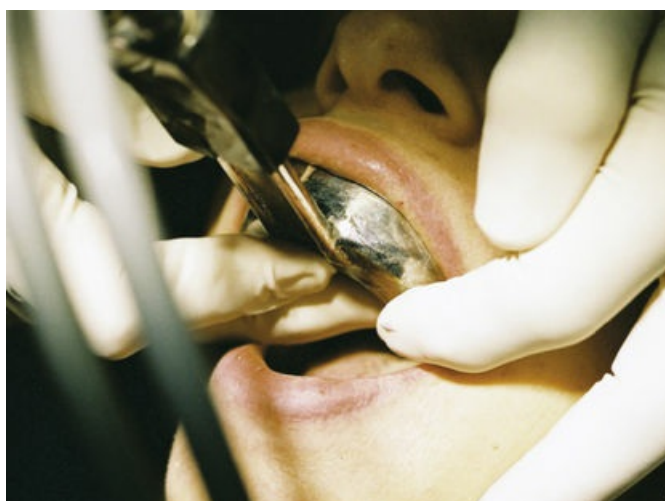



Instrument

Laboratory Spatula

Functions

To mix powder and a liquid in a flexible bowl

To mix and shape laboratory plaster, stone, and die stone for models

Characteristics

Spatula straight to help manipulate material

Range of sizes

Practice Note

Laboratory Spatula is used with vibrator.

Sterilization Notes

Preclean and disinfect Laboratory Spatula, if contaminated, after each use according to the manufacturer's recommendation. Refer to state regulations for any additional state requirements.





Instrument

Vibrator for Laboratory

Function

To vibrate material in mixing bowl to remove air bubbles from mixing plaster, stone, or die stone

Characteristics

Use vibrator after mixing the plaster or stone.

Use vibrator while adding plaster or stone to impression to eliminate air bubbles in impression.

Practice Note

Place plastic cover on vibrator work surface to keep vibrator free from material.

Sterilization Notes

Preclean and disinfect vibrator, if contaminated, according to the manufacturer's recommendation.





Instrument

Vacuum Mixing Unit

Functions

To vacuum mix all types of gypsums, plasters, and investment materials
To program digitally type of material being mixed
To remove excessive air from material while mixing

Characteristics

Vacuum mixing unit uses blades to mix material and vacuums air bubbles
Bowl with blades attaches to unit and mixes material automatically
Vacuum system within the unit removes excess air for smoother material consistency

Practice Note

Vacuum Mixer used in dental office labs and dental laboratories for better consistency of material for models and investment material for cast crowns.

Sterilization Notes

Preclean and disinfect Vacuum Mixing Unit and Mixing Bowls, if contaminated, according to manufacturer's recommendation.



Instrument

Laboratory Knife

Functions

To use for separating impressions from model(s)
To use for hand-trimming models
To use on any type of appliance for hand trimming

Characteristics

Range of sizes
Usually has green wooden handle—Referred to as Green Handle Lab Knife

Practice Note

Laboratory Knife is used in dental office setting and dental laboratories.

Sterilization Notes

Preclean and disinfect Laboratory Knife, if contaminated, according to manufacturer's recommendation. Refer to state regulations for any additional state requirements.



Instrument

Model Trimmer

Function

To trim plaster, stone, or die stone models

Characteristics

Trimmer has an abrasive grinding wheel to grind excess plaster, stone, and die stone from the models.

Water runs next to the grinding wheel to reduce heat, reduce the dust created by grinding, and keep the wheel clean.

Practice Notes

Diagnostic models, orthodontic models, and crown and bridge models are all trimmed differently. Glasses and mask should be worn while trimming models.

Unit should have splash guards.

Sterilization Notes

Preclean and disinfect Model Trimmer, if contaminated, according to the manufacturer's recommendation.

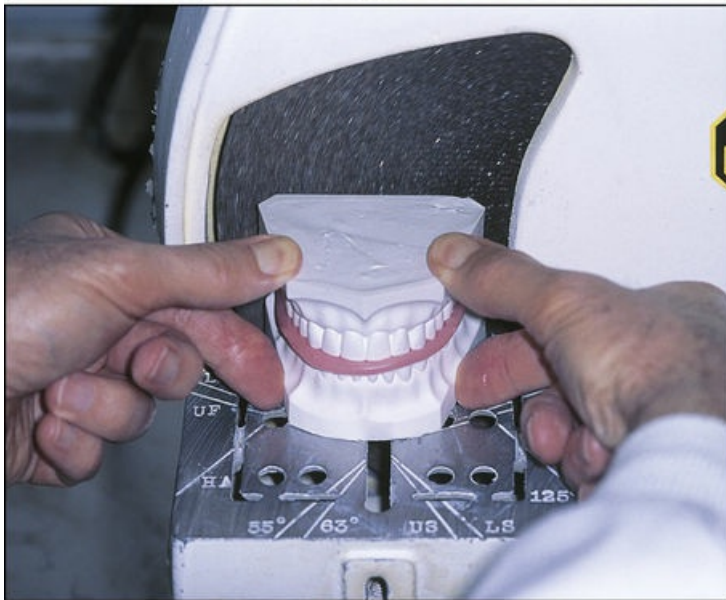

Instrument

Flexible Mixing Spatula

Function

To mix dental materials

Characteristics

Flexible metal to allow proper manipulation
Range of sizes

Practice Note

Flexible Mixing Spatula is used on most restorative, endodontic, orthodontic, and periodontic tray setups.

Sterilization Notes

Flexible Mixing Spatula must be precleaned, either, placed in a sterilizing pouch with an internal process indicator, sealed, then sterilized OR wrapped with an internal process indicator inside and secured on the outside with process indicator tape, then sterilized. Verify appropriate color change has been achieved in external process indicator immediately after removal from sterilizer then check internal process indicator before treatment. Refer to state regulations for any additional state requirements.



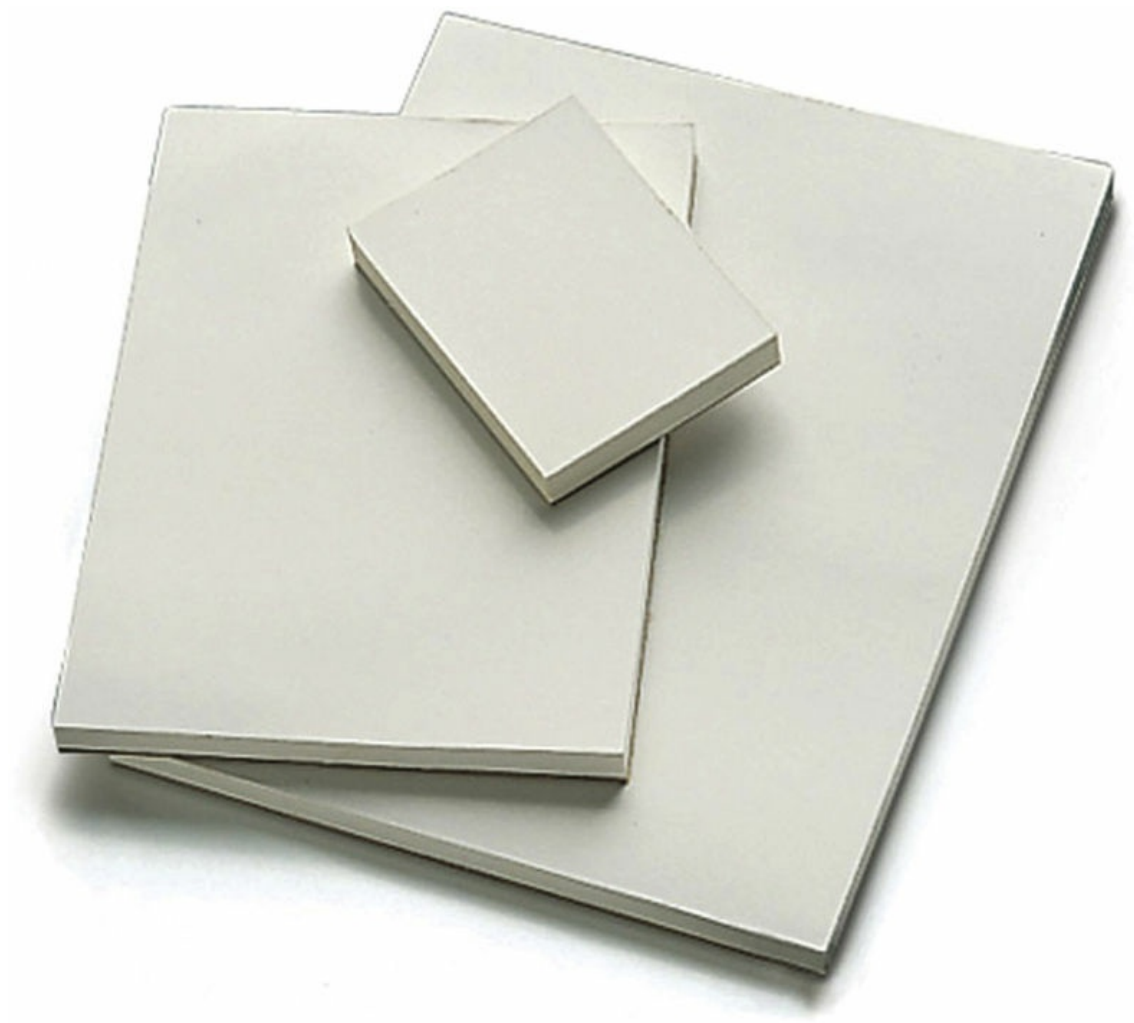

Instrument

Paper Mixing Pads

Function

To mix all types of dental materials

Characteristics

Each paper on the pad is coated so material will not seep through the paper.
Many types and sizes available

Practice Note

Many materials have special paper pads that must be used when mixing certain materials.

Sterilization Notes

Remove one paper to mix each material and not contaminate the pad. Entire pad should not be used to mix unless overgloves are used.



20

Dental Imaging and Diagnostic Equipment

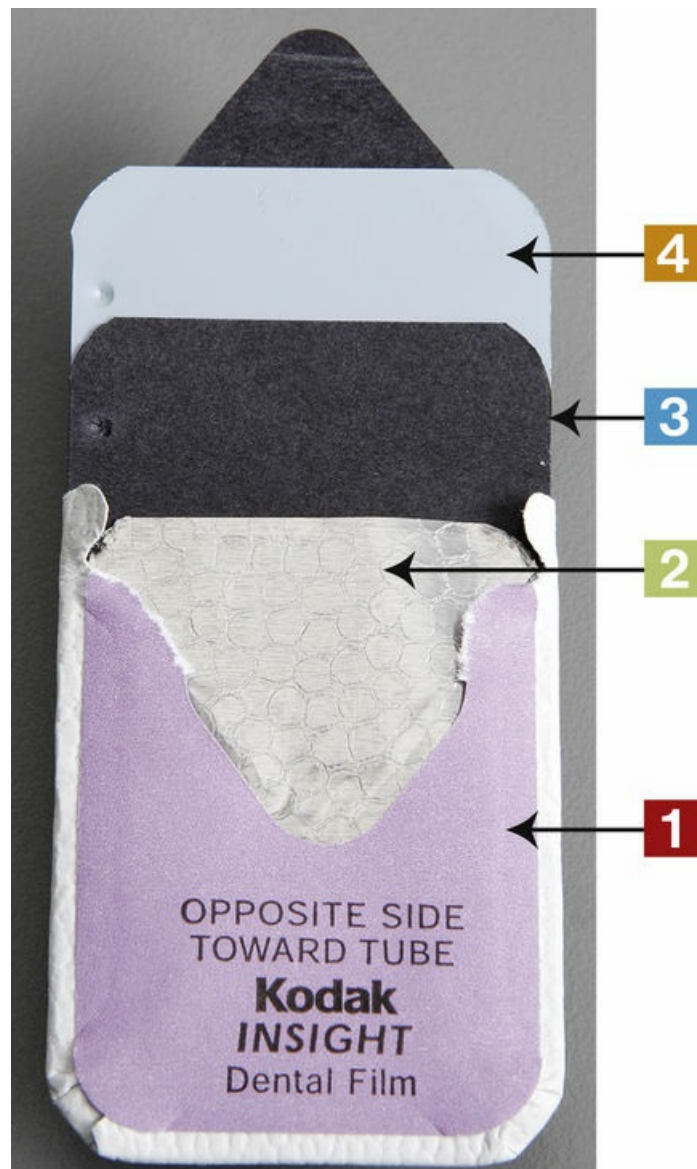

Instrument

Intraoral Dental Film

Function

To capture the image of teeth in the radiographic process

Characteristics

- Outside covering of film—Soft plastic or paper (both waterproof)
- Sheet of lead foil to stop the radiation from extending beyond the film
- Black paper to protect the film from light penetration
- Film—Single or double film

Film speed indicated on each packet—Set by American National Standards Institute (ANSI)

Film speed A through F—D, E, F used intraorally

Faster speed of the film reduces the amount of radiation exposure; F speed is faster than D speed.

Film speed determines amount of radiation needed to produce a quality radiograph—Settings are on x-ray unit.

Practice Note

Intraoral Dental X-ray Film is used in all phases of dentistry.

Sterilization Notes

Follow standard precautions and cross-contamination protocol when exposing and processing film for developing. Outer packet and black paper may be disposed of in the garbage. Correct disposal of lead foil must be checked within your state. In some states, lead foil is considered a hazardous waste and must be collected and disposed of properly. For proper recycling protocol, refer to Department of Environmental Health regulations in the state where you practice.

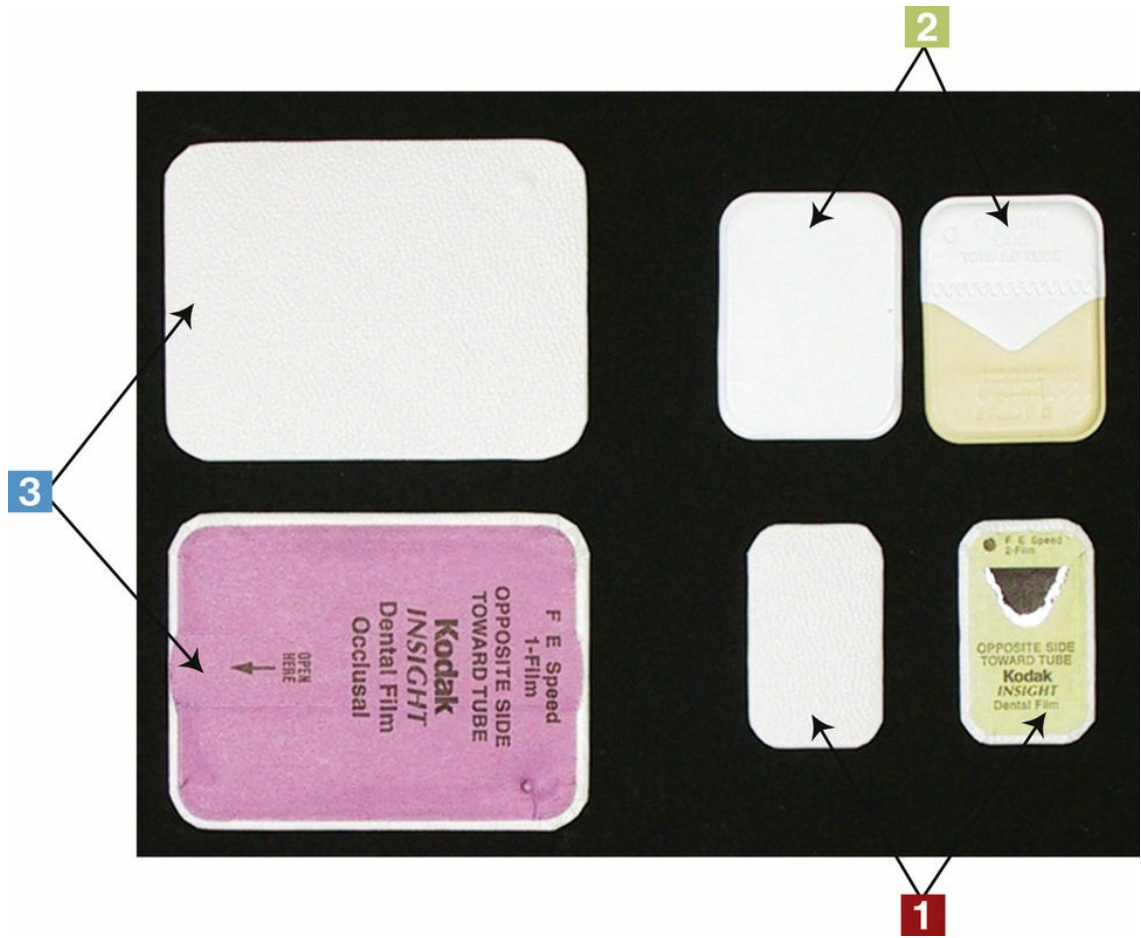

Instrument

Intraoral Dental Film—Various Sizes

Functions

To project an image of the patient's teeth through x-ray onto the film
To use for intraoral and extraoral projections

Characteristics

Commonly taken radiographs—Front and back view

Size #0—Taken on children under 3 (not pictured)

■ Size #1—Used for Anterior periapical image (narrow view)

■ Size #2—Used for Periapical and bite-wing image

Size #3—Used for extended bitewing projections (not pictured)

■ Size #4—Used for occlusal projections; taken to view maxillary and mandibular teeth: commonly taken on children

Practice Notes

Smooth side of the film (the raised-dot side—convex) faces the x-ray tube or position-indicating device (PID). Raised dot should be toward the occlusal or incisal.

Sterilization Notes

Follow standard precautions and cross-contamination protocol when exposing and processing film for developing. Outer packet and black paper may be disposed of in the garbage. Correct disposal of lead foil must be checked within your state. In some states, lead foil is considered a hazardous waste and must be collected and disposed of properly. For proper recycling protocol, refer to Department of Environmental Health regulations in the state where you practice. Refer to state regulations for any additional state requirements.



Instrument

Package of Dental Film

Function

To package intraoral dental film

Characteristics

Box labeled:

- Type of film
- Film speed
- Number of films in individual film packet
- Number of film packets in the box
- Expiration date of film

Film packets—Single or double film

Practice Notes

Each film has an identification dot (raised bump). Concave on one side and convex on the other.

Convex/bump faces toward the teeth when placing the x-ray.

Film storage is important to the integrity of the film. Refer to package instructions for storage recommendations.

Sterilization Notes

Follow standard precautions and cross-contamination protocol when processing film for developing. Outer packet and black paper may be disposed of in the garbage. Correct disposal of lead foil must be checked within your state. In some states, lead foil is considered a hazardous waste and must be collected and disposed of properly. For proper recycling protocol, refer to Department of Environmental Health regulations in the state where you practice.



Instrument

Bite-Wing Tabs

Function

To take a bite-wing radiograph projection

Characteristics

- Stick-on tab
- Slip-on tab

Tab or wing is placed on the occlusal, and patient bites on the tab to secure the film.

Practice Notes

Slip-on tabs are available in different sizes to accommodate different-sized film.

Size #2 film is used for adult bite-wing radiograph.

Bite-wing radiographs are mainly used for diagnosing caries on proximal surfaces (mesial and distal) of the posterior teeth.

Four bite-wings are usually taken on adult dentition—One premolar and one molar projection on each side of the mouth.

Sterilization Notes

Follow standard precautions and cross-contamination protocol when exposing and processing film. Outer packet, black paper, and Bite-Wing Tabs may be disposed of in the garbage. Correct disposal of lead foil must be checked within your state. In some states, lead foil is considered a hazardous waste and must be collected and disposed of properly. For proper recycling protocol, refer to Department of Environmental Health regulations in the state where you practice.



Instrument

Film Holder—Periapical (EeZee-Grip)

Function

To position and hold the film in patient's mouth for periapical images

Characteristics

Double ended:

- One end holds film for posterior teeth projection, as shown.
- Opposite end holds film for anterior teeth projection.

Practice Notes

Size #2 film used for posterior periapical image

Size #1 or #2 used for anterior periapical image

Periapical images used for viewing the coronal part of the tooth, root, apex, and surrounding bone and tissue

EeZee-Grip formerly called Snap-a-ray

Sterilization Notes

EeZee-Grip Film Holder must be precleaned open and unlocked, placed in an open and unlocked position either in a sterilizing pouch with an internal process indicator, sealed, then sterilized OR wrapped with an internal process indicator inside and secured on the outside with process indicator tape, then sterilized. Verify appropriate color change has been achieved in external process indicator immediately after removal from sterilizer then check internal process indicator before treatment. Refer to state regulations for any additional state requirements.

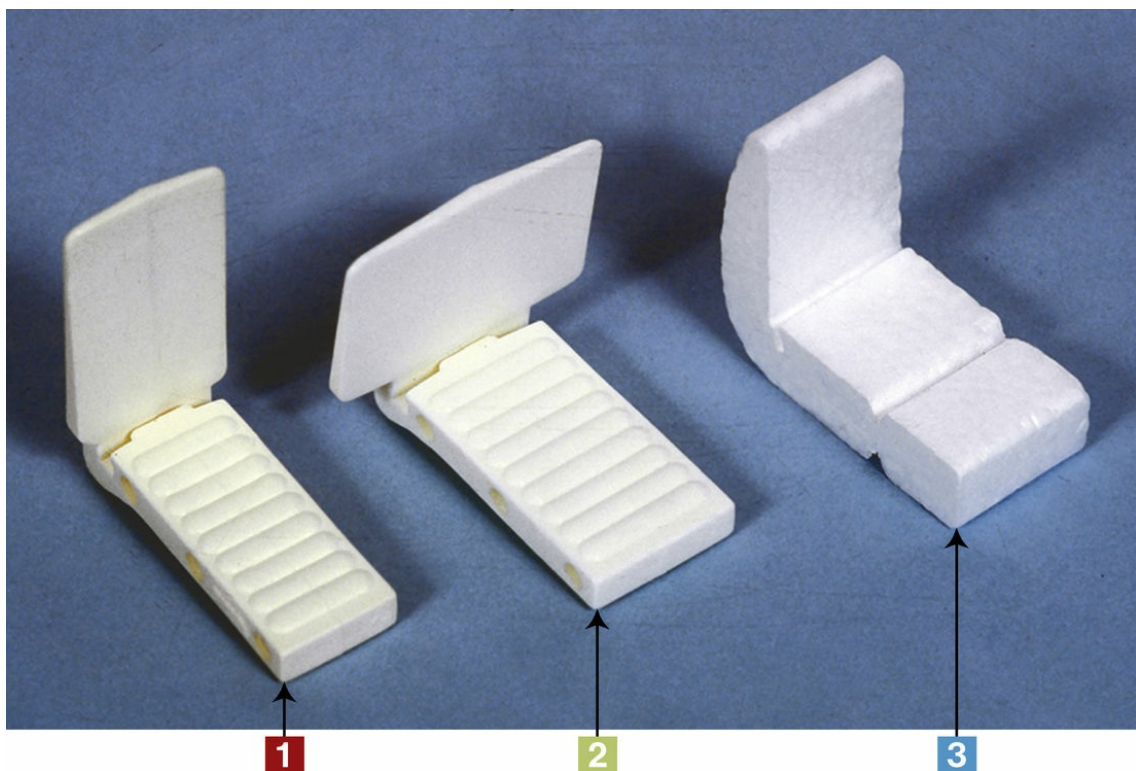

Instrument

Film Holders—Periapical

Functions

To position and hold a film in patient's mouth for periapical image

To allow patient to bite on holder to keep film in place while positioning the position-indicating device (PID) and exposing the film

Characteristics

- Holds film for anterior teeth projection—Plastic that can be sterilized
 - Holds film for posterior teeth projection—Plastic that can be sterilized
 - Holds film for anterior and posterior projection—Disposable Styrofoam (one time use)
- Slot holds film in place

Practice Note

Periapical images are used for viewing the coronal part of the tooth, root, apex, and surrounding bone and tissue.

Sterilization Notes

Plastic Film Holders must be precleaned, either, placed in a sterilizing pouch with an internal process indicator, sealed, then sterilized OR wrapped with an internal process indicator inside and secured on the outside with process indicator tape, then sterilized. Verify appropriate color change has been achieved in external process indicator immediately after removal from sterilizer then check internal process indicator before treatment. Refer to state regulations for any additional state requirements. Disposable Styrofoam holder may be disposed of in garbage.

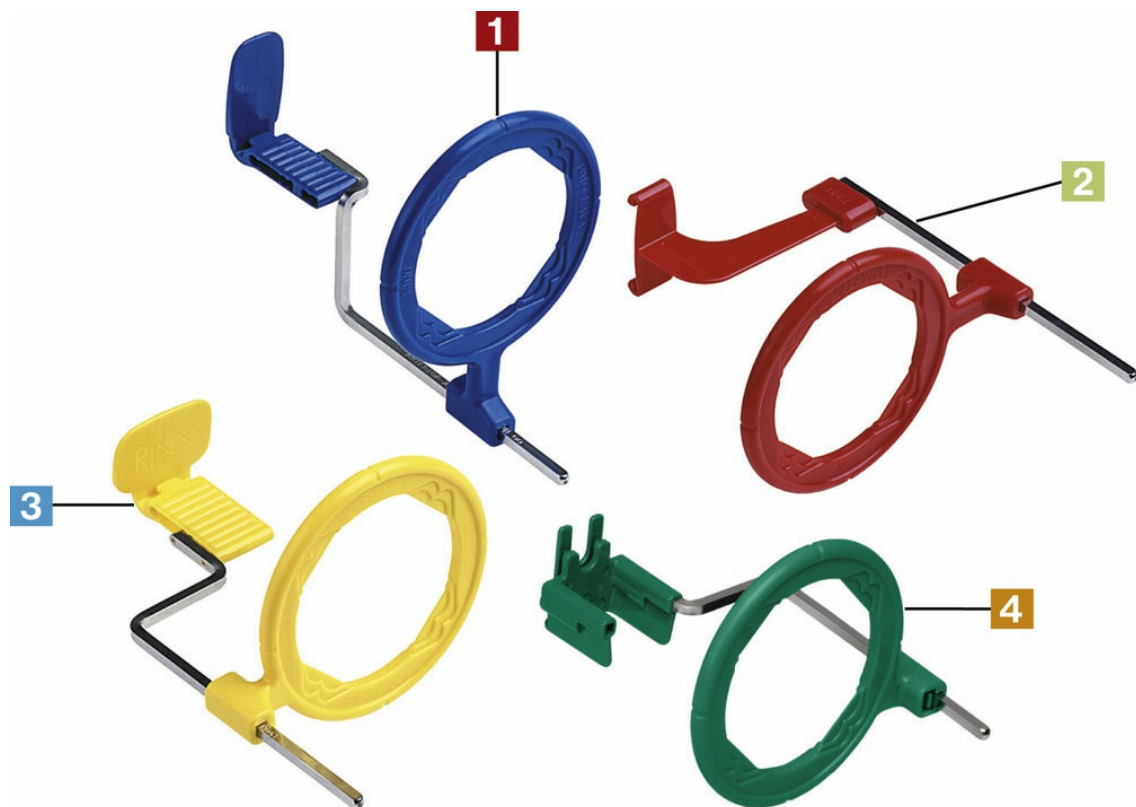

Instrument

Film Holders—XCP

Functions

To position and hold a film in patient's mouth for periapical and bite-wing images using parallel technique

To allow patient to bite on holder to keep film in place while positioning the position-indicating device (PID) and exposing the film

Characteristics

- Blue—Anterior teeth projection
 - Red—Bite-wing projection
 - Yellow—Posterior teeth projection
 - Green—Projections for endodontic procedures
- Slot holds film in place.

Practice Notes

XCP uses the parallel technique for exposing radiation to the film.

PID is parallel with the ring on the XCP.

Sterilization Notes

Film Holders must be precleaned, either, placed in a sterilizing pouch with an internal process indicator, sealed, then sterilized OR wrapped with an internal process indicator inside and secured on the outside with process indicator tape, then sterilized. Verify appropriate color change has been achieved in external process indicator immediately after removal from sterilizer then check internal process indicator before treatment. Refer to state regulations for any additional state requirements.



Instrument

Lead Aprons

Function

To place on patient for protection against scattered x-rays during exposure of x-ray film

Characteristics

- Lead apron
- Lead apron with collar to protect thyroid area
- Lead apron poncho for front and back protection

Practice Notes

Lead Apron must be used when exposing patient to dental x-rays.
Lead aprons should not be folded.

Sterilization Notes

Preclean and disinfect Lead Apron according to the manufacturer's recommendation.





Instrument

Radiation Monitoring Device

Functions

- To place on operator's protective clothing while employee is working in a dental office or radiography lab
- To use as a Direct Ion Storage, DIS, dosimeter constructed with non-volatile analog memory cells surround by gas-filled ion chambers
- To measure the ionizing radiation exposure dose incident on the dosimeter by calculating the amount of proportional change in the voltage across the memory cells

Characteristics

- Each badge includes employee's name, wear and account number, and the radiation monitoring device (dosimeter).
- Radiography monitoring device should be worn for traditional and digital projections.

Practice Note

At the end of a reporting period, or anytime the user wants to check the dose reading on-demand, the dosimeter radiation exposure report can be read instantly and automatically via a mobile device app, localized reader, or computer. The user can also set up high-dose notification alerts or configure badge reassignments online.

Sterilization Notes

If contaminated, disinfect Radiation Monitoring Device according to the manufacturer's recommendation. Refer to state regulations for any additional state requirements.



Instrument

Dental X-Ray Unit

Function

To expose film with radiation that is generated in the x-ray unit

Characteristics

- Position-indicating device (PID)
 - Tube head
 - X-ray unit
- Round or rectangular PIDs available

Practice Note

Control panel for the x-ray unit and button to expose the film are outside patient's treatment room. On some machines, you may adjust the exposure time the x-ray is exposed. Other machines adjust the exposure time, kilovoltage peak (kVp), and milliamperage (mA).

Sterilization Notes

Follow standard precautions and cross-contamination protocol when exposing and processing film. Barriers should be used on x-ray tube head, PID, and panel where x-ray button is pushed. Follow manufacturer's recommendation for precleaning and disinfection of the Dental X-Ray Unit. Refer to state regulations for any additional state requirements.

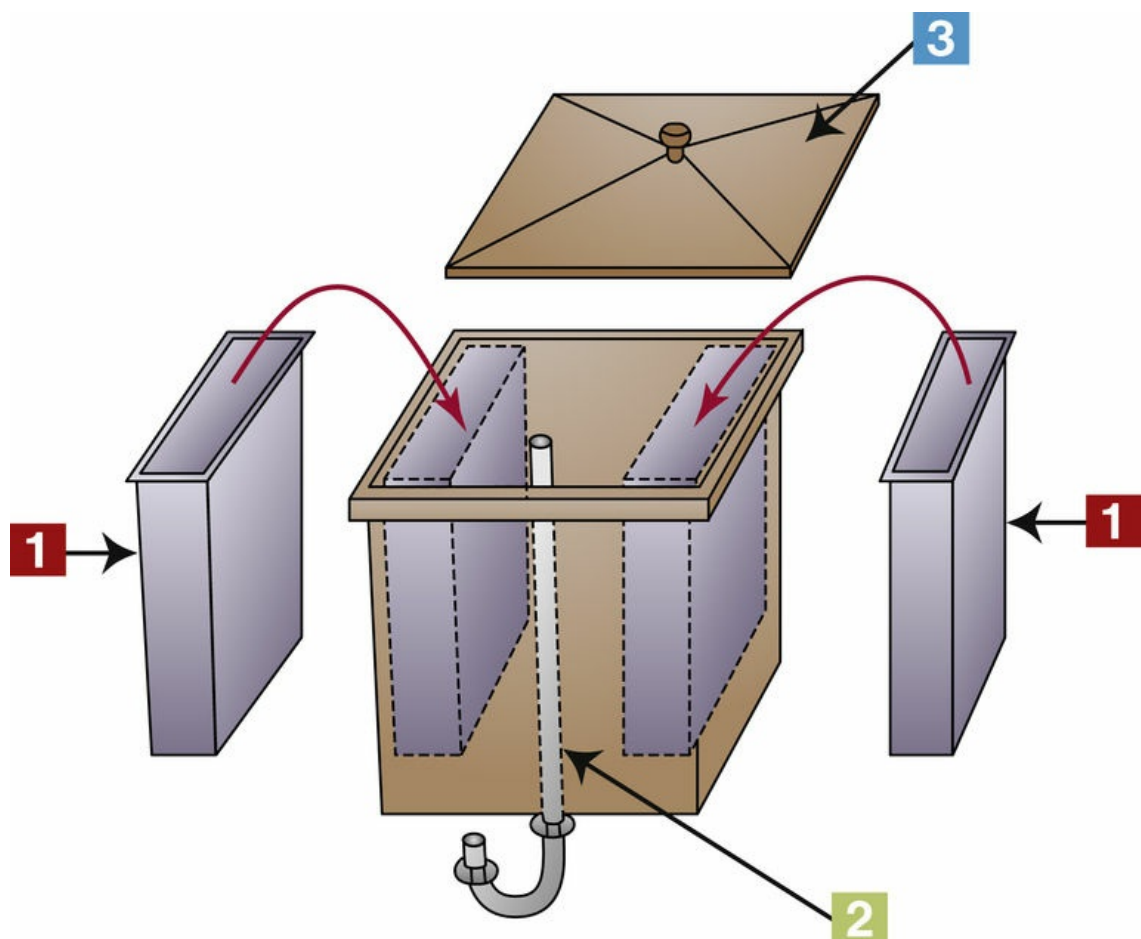

Instrument

Manual Developing Unit

Functions

To manually develop exposed dental radiographic films taken on patients
To develop, rinse, fix, and wash dental radiographic films
To develop dental radiographic films in a darkroom with only a safelight

Characteristics

- Tank insert for the developing and fixing solution
Developer in left tank; fixer in right tank
- Water bath and rinsing tank with constant running water in tank
- Cover for unit

Practice Note

Developing time depends on the temperature of the running water. The water will determine the temperature of the developer and fixer solutions. A table with the temperature denotes the time to develop and fix. Fixer time is double the developing time. The wash time is 20 minutes after the film has been fixed.

Sterilization Notes

Follow standard precautions and cross-contamination protocol when processing film. For proper recycling protocol for solutions, refer to Department of Environmental Health regulations in the state where you practice. Follow local and state regulations in disposal of developer and fixer solution.

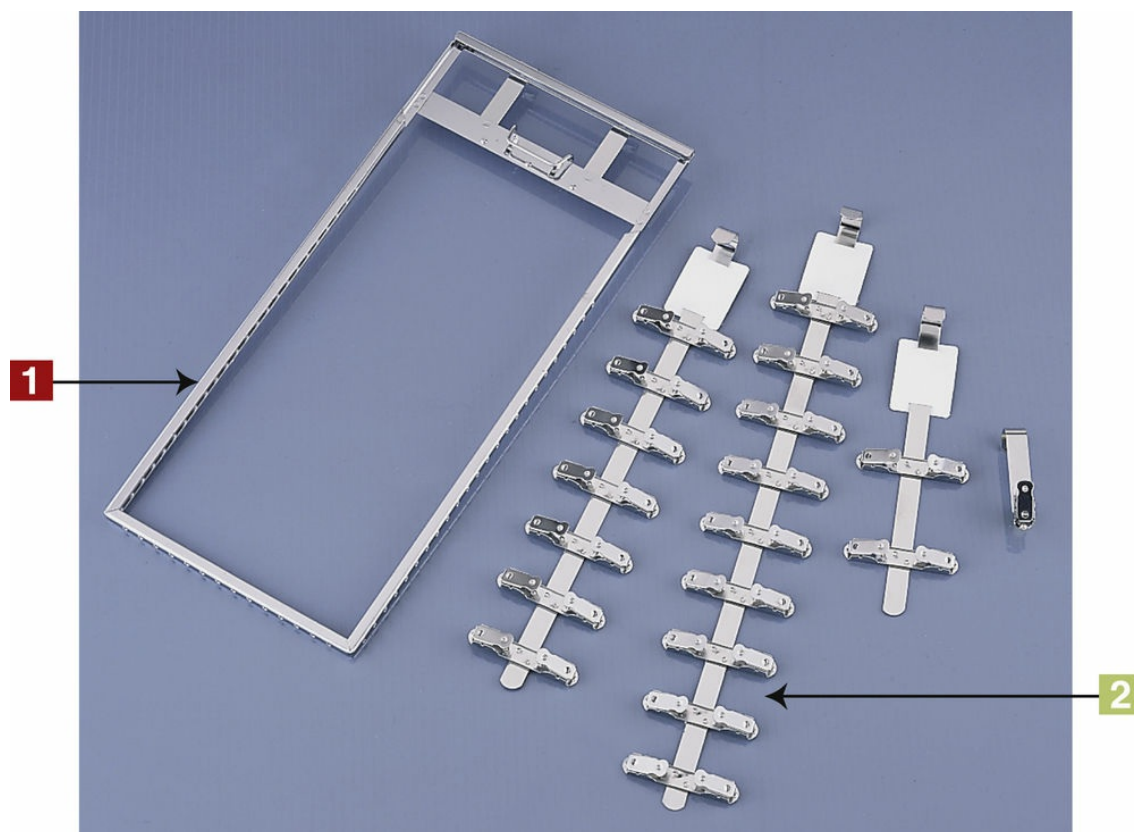

Instrument

Film Rack

Functions

To place undeveloped film on the rack in the darkroom with only the safelight before putting rack in the developer

To place film on rack without touching each other

Characteristic

- Panoramic rack
 - Individual single film racks
- Various sizes of racks available

Practice Note

Keep films on rack through the entire process: develop, rinse, fix, wash, and dry.

Sterilization Notes

Follow standard precautions and cross-contamination protocol when processing film. Outer packet and black paper may be disposed of in the garbage. Correct disposal of lead foil must be checked within your state. In some states, lead foil is considered a hazardous waste and must be collected and disposed of properly. For proper recycling protocol, refer to Department of Environmental Health regulations in the state where you practice. Disinfect racks according to manufacturer's recommendation. Refer to state regulations for any additional state requirements.

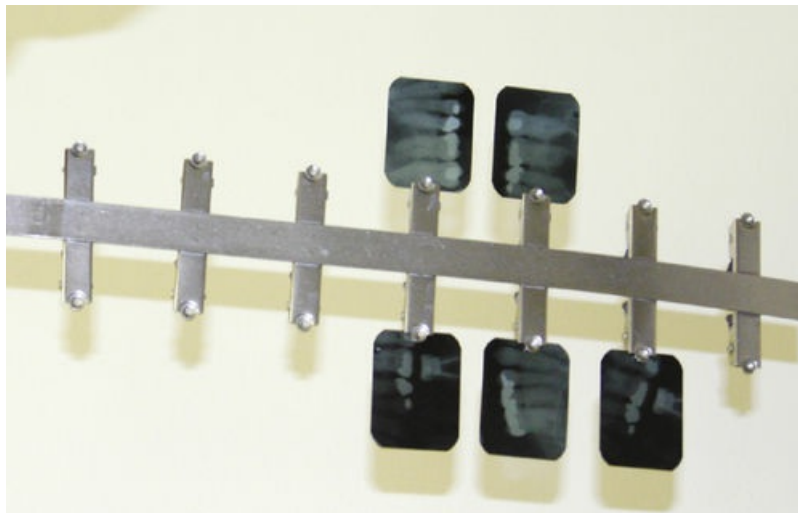

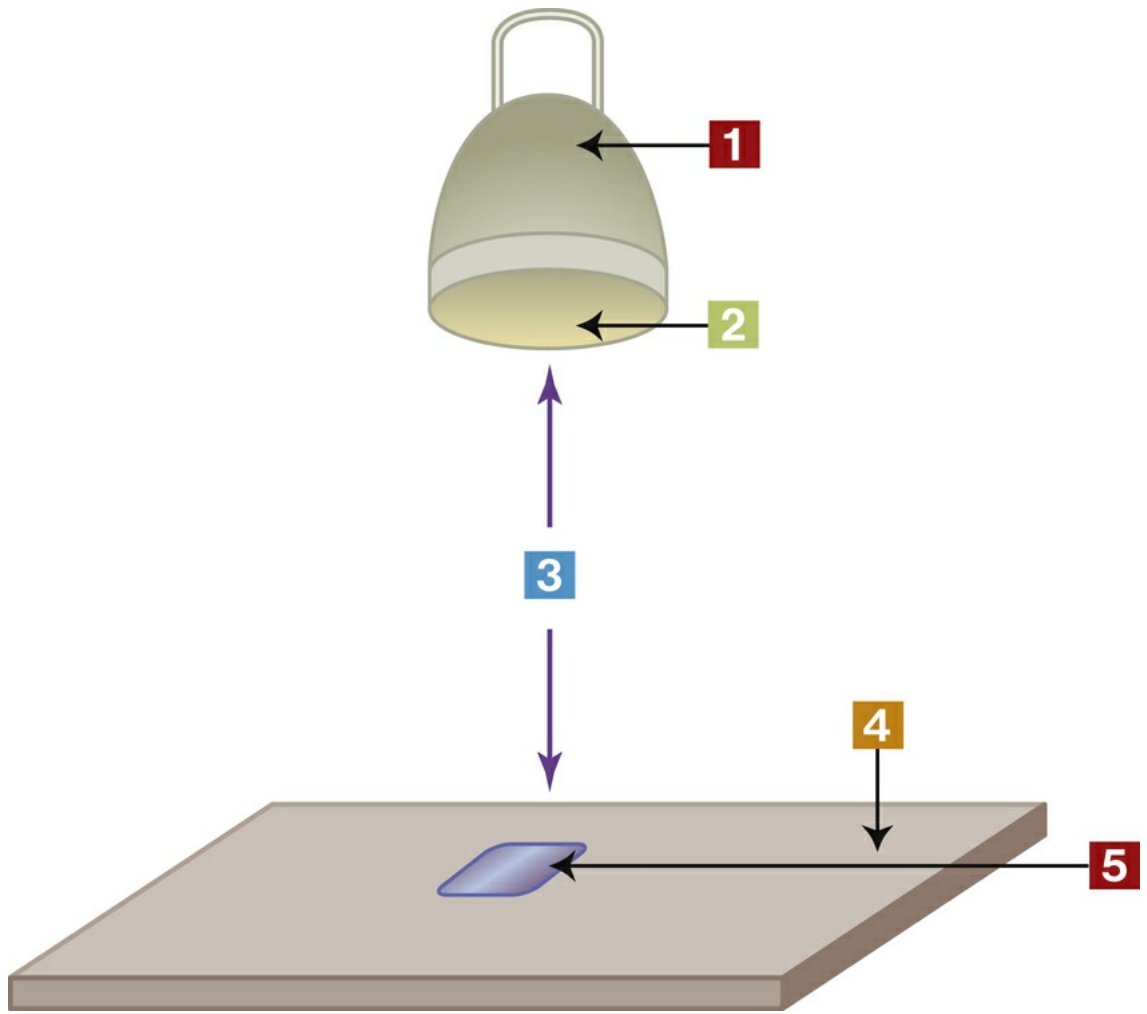

Instrument

Safelight

Function

To provide enough illumination in the darkroom to process films safely without exposing or damaging the film

Characteristics

- Safelight
- Safelight filter
- Minimum distance (at least 4 feet) from safelight to undeveloped x-ray
- Working area
- Undeveloped and unwrapped film

Practice Note

Unwrapped film left too close to the safelight or exposed for more than 2 to 3 minutes will appear fogged.

Sterilization Notes

Follow standard precautions and cross-contamination protocol when processing film. Preclean and disinfect area if contaminated.



Instrument

Automatic Film Processor

Functions

To automatically develop x-ray film in darkroom
To develop x-ray film

Characteristics

- Automatic processor
 - Front loader—Hands go into a dark area to unwrap film. View area from top. Darkroom not needed.
- Various types of processors available

Practice Note

Dentist is able to diagnose x-ray film once film is dry, which is a great advantage of an automatic processor.

Sterilization Notes

Follow standard precautions and cross-contamination protocol when processing film. Outer packet and black paper may be disposed of in the garbage. Correct disposal of lead foil must be checked within your state. In some states, lead foil is considered a hazardous waste and must be collected and disposed of properly. For proper recycling protocol, refer to Department of Environmental Health regulations in the state where you practice. Follow local and state regulations in disposal of developer and fixer solution. Refer to state regulations for any additional state requirements.

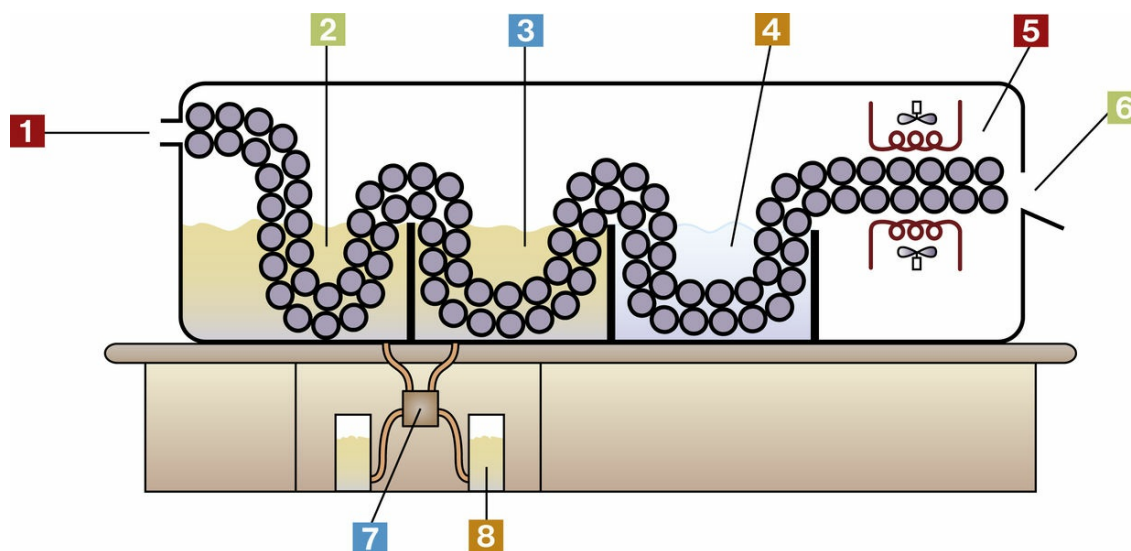

Instrument

Parts of Automatic Film Processor

Functions

To automatically develop x-ray film

To place film in processor to develop, fix, wash, dry; film then ready to mount

Characteristics

- Slot to feed film
- Roller transporter in developer tank
- Roller transporter in fixer tank
- Roller transporter in water tank
- Roller transporter in drying compartment
- Film releases from rollers onto recovery slot
- Pump to replenish developer and fixer
- Replenishing solution for developer and fixer

Practice Note

Developer and fixer solutions for the automatic processor are different from those for manual processing.

Sterilization Notes

Follow standard precautions and cross-contamination protocol when processing film. Outer packet and black paper may be disposed of in the garbage. Correct disposal of lead foil must be checked within your state. In some states, lead foil is considered a hazardous waste and must be collected and disposed of properly. For proper recycling protocol for solutions, refer to Department of Environmental Health regulations in the state where you practice. Follow local and state regulations in disposal of developer and fixer solution. Refer to state regulations for any additional state requirements.



Instrument

View Luminator

Function

To view traditional radiographs for diagnosis

Characteristics

Various sizes and styles of view luminators
Also referred to as view box

Practice Note

View boxes are located in each patient treatment room.

Sterilization Notes

If contaminated, preclean and disinfect View Luminator according to the manufacturer's recommendation.





Instrument

Film Duplicator

Function

To duplicate dental radiographic film

Characteristics

Produces white light to expose film
Various sizes and styles available

Practice Notes

All phases of dentistry use film duplicators. Some dental offices use double-pack dental radiographic film instead of duplicating the film.
Electronic devices are available for duplicating dental radiographs.
Duplicated films are sent to insurance companies or referring specialists. If using double-packet dental radiographic film or digital radiography, duplication is not necessary.

Sterilization Notes

If contaminated, preclean and disinfect Film Duplicator according to the manufacturer's recommendation.

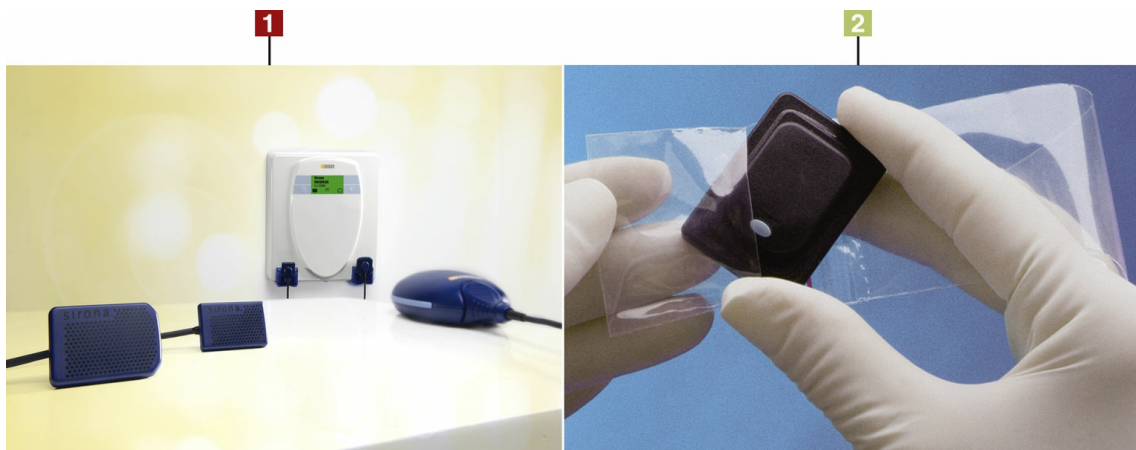

Instrument

Intraoral Sensors for Digital Images

Functions

To take digital intraoral images without film or without processing the film

To project the image of the teeth by digitally projecting radiation onto an electronic sensor and to computerized imaging system before going to computer storage

Characteristics

Different styles and systems of sensors and digital radiography available

Different size sensors available: sizes 1, 2, and 3

■ Some sensors have wire connecting to the computer.

■ Some sensors do not have wire but are put into a specially designed computer after exposure.

Picture shows barrier placed on sensor.

Practice Notes

Paperless dental offices store digital x-rays on the computer, along with patient records.

Digital image may be printed out on special paper if a copy is required.

Barriers for sensors (refer to image 2 on page 698)

Sterilization Notes

Follow standard precautions and cross-contamination protocol when exposing digital film. Barriers must be placed on the sensors. Barriers must be used and the manufacturer's recommendation for disinfection followed. Refer to state regulations for any additional state requirements.

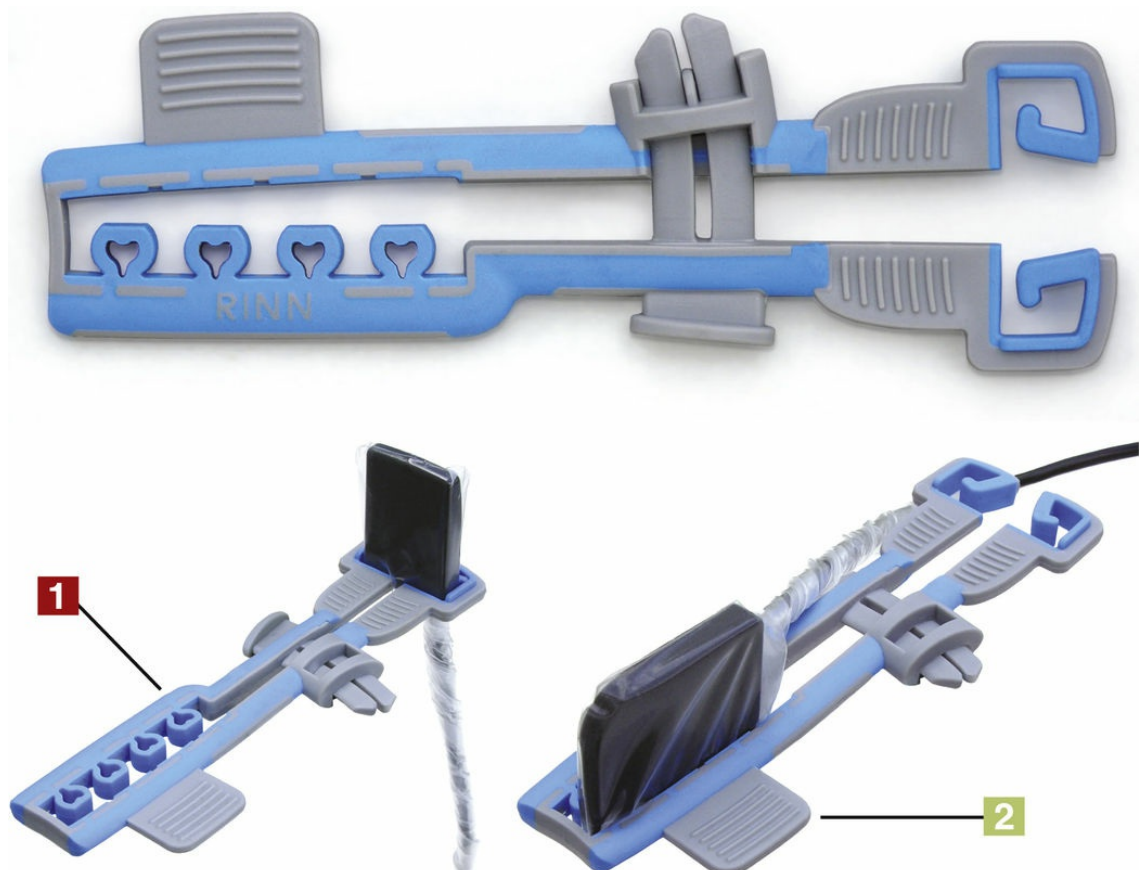

Instrument

Holder for Digital Sensor (EeZee-Grip)

Function

To position and hold a digital x-ray sensor in patient's mouth for periapical images

Characteristics

Double ended:

- Holds film for anterior teeth projection — barrier placed on sensor
 - Holds film for posterior teeth projection — barrier placed on sensor
- Designed for snug fit to prevent slipping

Practice Notes

Holder allows room for the wire attached to the sensor
May be used with wireless digital sensor

Sterilization Notes

Follow standard precautions and cross-contamination protocol when taking digital images. Holder must be precleaned open and unlocked, placed in an open and unlocked position either in a sterilizing pouch with an internal process indicator, sealed, then sterilized OR wrapped with an internal process indicator inside and secured on the outside with process indicator tape, then sterilized. Verify appropriate color change has been achieved in external process indicator immediately after removal from sterilizer then check internal process indicator before treatment. Refer to state regulations for any additional state requirements.

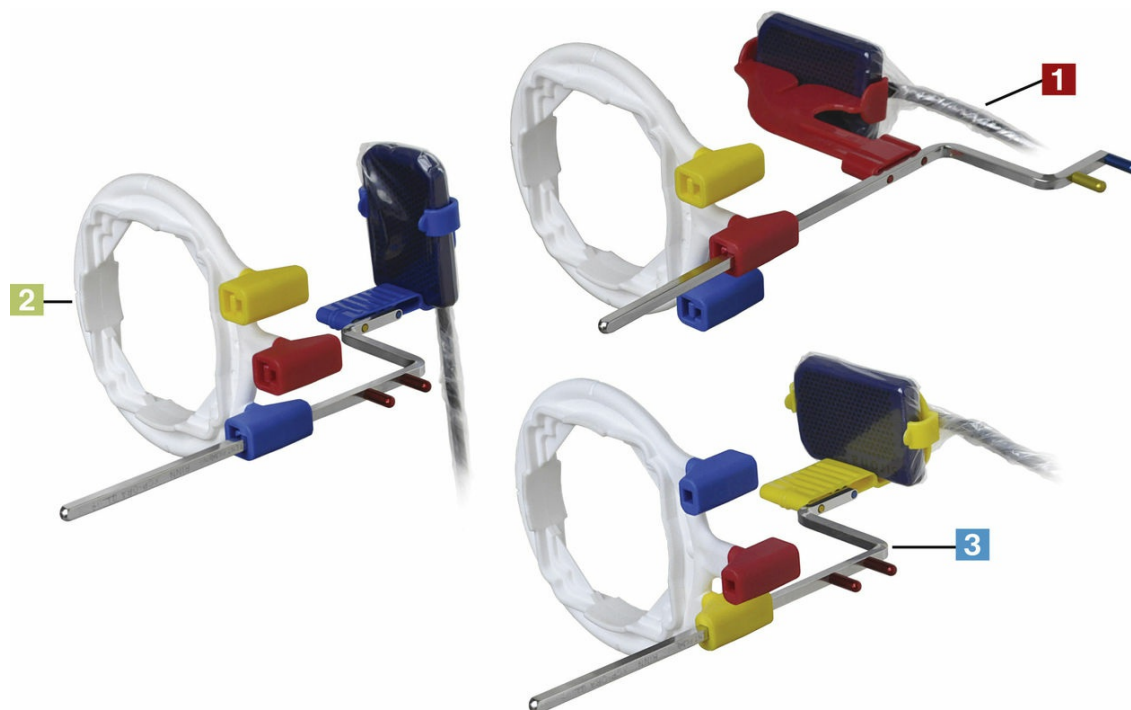

Instrument

One Ring and Arm Positioning System

Functions

To position and hold digital sensors or film in patient's mouth for periapical and bite-wing images using parallel technique

To allow patient to bite on holder to keep digital sensor or film in place while positioning the position-indicating device (PID) and exposing the sensor or film

Reduces the number of components needed for positioning—one arm, one ring

Characteristics

- Holds film for bite-wing projection—barrier placed on sensor
 - Holds film for anterior and posterior teeth projections—barrier placed on sensor
 - Holds film for posterior teeth projection—barrier placed on sensor
- Slots on ring are color coded—blue, anterior; yellow, posterior; red, bite-wing
Allows sufficient amount of space for sensors with wires

Practice Notes

Uses the parallel technique for exposing radiation to the sensor or film

PID is parallel with the ring using a round or square PID

Sterilization Notes

Disassembled Holders must be precleaned, either, placed in a sterilizing pouch with an internal process indicator, sealed, then sterilized OR wrapped with an internal process indicator inside and secured on the outside with process indicator tape, then sterilized. Verify appropriate color change has been achieved in external process indicator immediately after removal from sterilizer then check internal process indicator before treatment. Refer to state regulations for any additional state requirements.

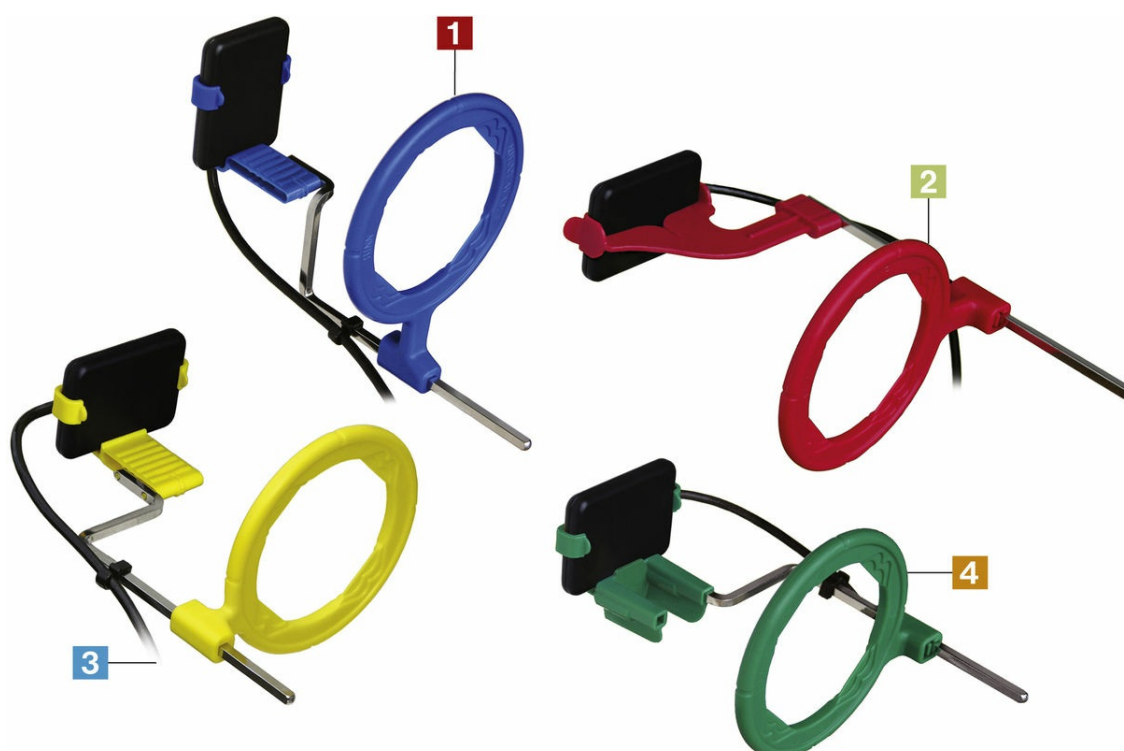

Instrument

Rinn XCP Holders for Digital Sensors

Functions

To position and hold digital sensor in patient's mouth for periapical and bite-wing images, using parallel technique

To allow patient to bite on holder to keep sensor in place while positioning the position-indicating device (PID) and exposing the electronic sensor

Characteristics

- Blue—Holds film for anterior teeth projection
 - Red—Holds film for bite-wing projection
 - Yellow—Holds film for posterior teeth projection
 - Green—Holds film when taking projections for endodontic procedures
- Slots hold electronic sensor in place with barriers placed on sensor and wire.

Practice Note

Several different styles of electronic sensor holders are available.

Sterilization Notes

Dissembled Holders must be precleaned, either, placed in a sterilizing pouch with an internal process indicator, sealed, then sterilized OR wrapped with an internal process indicator inside and secured on the outside with process indicator tape, then sterilized. Verify appropriate color change has been achieved in external process indicator immediately after removal from sterilizer then check internal process indicator before treatment. Refer to state regulations for any additional state requirements.





Instrument

Digital Intraoral X-Ray Unit

Functions

To take digital intraoral images without film or without processing the film

To project the image of the teeth by digitally projecting radiation onto an electronic sensor and then to computerized imaging system

Characteristics

- Position-indicating device (PID) (round)
 - Tube head
 - X-ray unit with digital panel
 - Rectangular PID
- Digital radiographs use less radiation than conventional radiographs.
Networks to computers in all areas of the dental office
Immediate imaging available

Practice Notes

Paperless dental offices store digital x-rays on the computer, along with patient records.
Used in all phases of dentistry, especially endodontics, orthodontics, oral surgery, and implantology.

Sterilization Notes

Follow standard precautions and cross contamination protocol when exposing and processing film. Barriers should be used on x-ray tube head, PID and panel where x-ray button is pushed. If barriers are not used follow manufacturer's recommendation for precleaning and disinfecting of the Dental X-Ray Unit. Refer to state regulations for any additional state requirements.



Instrument

Portable X-Ray Unit

Functions

To take intraoral images with a portable device

To expose digital sensors or conventional dental radiographic film

Characteristics

Wide color LCD with easy to recognize preset exposure; preset exposure time can be adjusted with one button

Unit has a 3.0-mA current

Features internal shielding and a backscatter shield to ensure safety and minimize x-ray exposure to operator and patient

Can be used in place of wall-mounted units

Practice Notes

The battery pack is separate from the body of the unit to minimize the weight and reduce stress on the operator's shoulders and arms.

Sterilization Notes

Follow standard precautions and cross-contamination protocol when exposing and processing film. Barriers should be used on X-ray Unit. If not, follow manufacturer's recommendation for precleaning and disinfection of the Dental X-Ray Unit. Refer to state regulations for any additional state requirements.



Instrument

SCANX Digital Imaging System

Function

To produce diagnostic intraoral digital images

Characteristics

Uses phosphor storage plates (PSPs)—Plastic plates coated with an x-ray sensitive phosphor material

Plates reused multiple times using one time only plastic barrier for each patient that covers the plates

Plates placed in machine to erase current image taken

Different size plates available for images

Compatible computer software needed for the SCANX digital images

Images appear on computer screen

Computer software compatibility of enhancing digital images to aid in diagnosis

Practice Note

Use regular intraoral x-ray machines for images

Use requirements—SCANX, computer and practice management software

Can be used in normal room lighting

Sterilization Notes

Follow standard precautions and cross-contamination protocol. Barriers must be used when exposing sensors. Each plastic plate is covered and closed with a plastic barrier. Plastic barrier is removed before placing in SCANX. New plastic barrier is used for each SCANX image. Plastic covers are one time use only and disposed of in garbage after each use. Refer to state regulations for any additional state requirements.

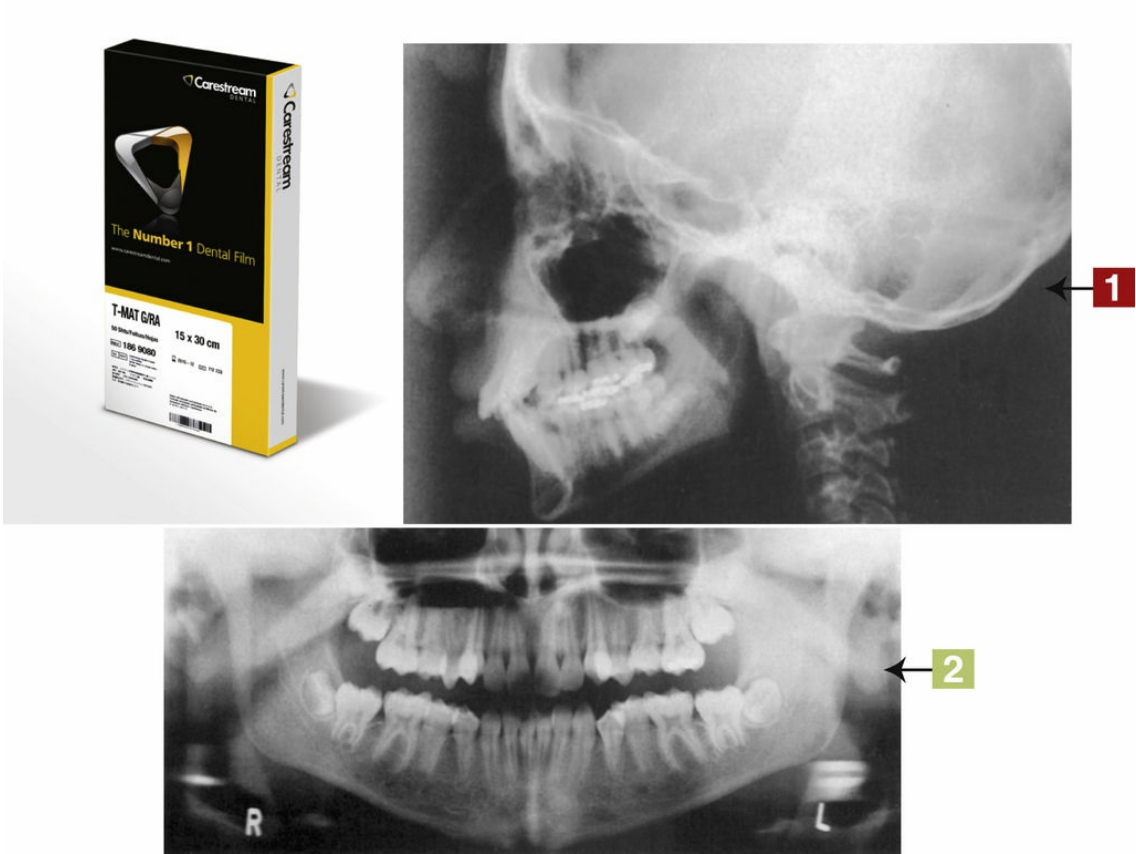

Instrument

Extraoral X-Rays—Cephalometric and Panoramic

Functions

To use to project the patient's teeth through x-ray onto the film
To use for extraoral projections

Characteristics

Film is placed in a cassette outside the mouth.

- Cephalometric radiograph—Shows bony and soft-tissue areas of the facial profile
- Panoramic radiograph—Shows a panoramic view of maxillary and mandibular teeth on one film

Practice Notes

Different styles of extraoral radiograph machines are available.

Cephalometric and panoramic digital radiographs

Cephalometric and panoramic radiographs are used in all phases of dentistry. Panoramic images are used frequently in orthodontics.

Sterilization Notes

Follow standard precautions and cross-contamination protocol when exposing and processing film for developing.



Instrument

Digital Panoramic/Cephalometric Imaging Unit

Functions

To take digital panoramic and cephalometric images without film or without processing the film
To project the image of maxillary and mandibular teeth by digitally projecting radiation onto an electronic sensor and then to computerized imaging system

Characteristics

Unit pictured is a 3 in 1 unit that takes both panoramic and cephalometric images. (It also takes 3D CBCT scans.)

Digital radiographs use less radiation than conventional radiographs.

Networks to computers in all areas of the dental office

Immediate imaging available

Practice Notes

Paperless dental offices store digital panoramic imaging on the computer, along with patient records.

Used in all phases of dentistry, especially orthodontics, oral surgery, and implantology. Panoramic and cephalometric images may also be taken with conventional film.

Sterilization Notes

Follow standard precautions and cross-contamination protocol. Barriers should be used, if not, then, follow the manufacturer's recommendation for precleaning and disinfection.

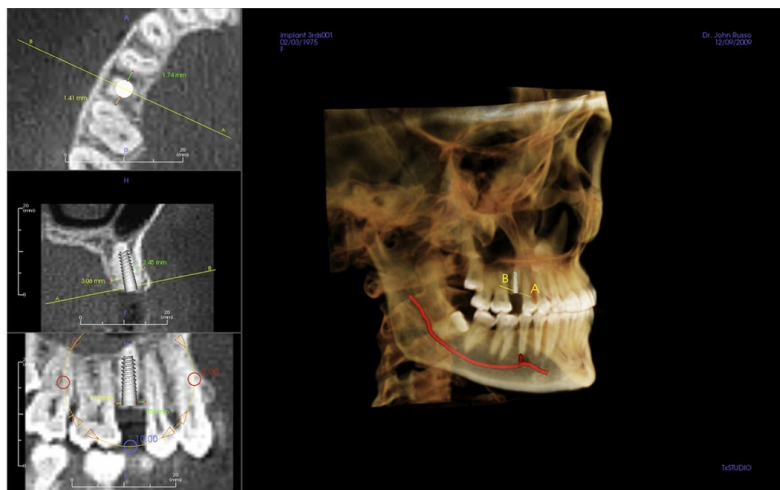

Instrument

Cone-Beam Three-Dimensional (3D) Imaging System

Function

To produce diagnostic 3D images of the head and neck as related to dentistry

Characteristics

High-resolution scans produce images at 0.2-mm voxel size to provide diagnosis for difficult areas to view with conventional radiographs.

Typical scan time of 8.9 seconds

Less radiation and more comfortable for the patient

Practice Note

Assists in diagnosis for enhanced orthodontic treatment planning, supernumerary teeth, abnormal anomalies, third molars, small root fractures, periodontal conditions, relationship of dentition, and other anatomy requiring detailed visualization

Sterilization Notes

Follow standard precautions and cross-contamination protocol. Barriers should be used, if not, then, follow the manufacturer's recommendation for precleaning and disinfection.

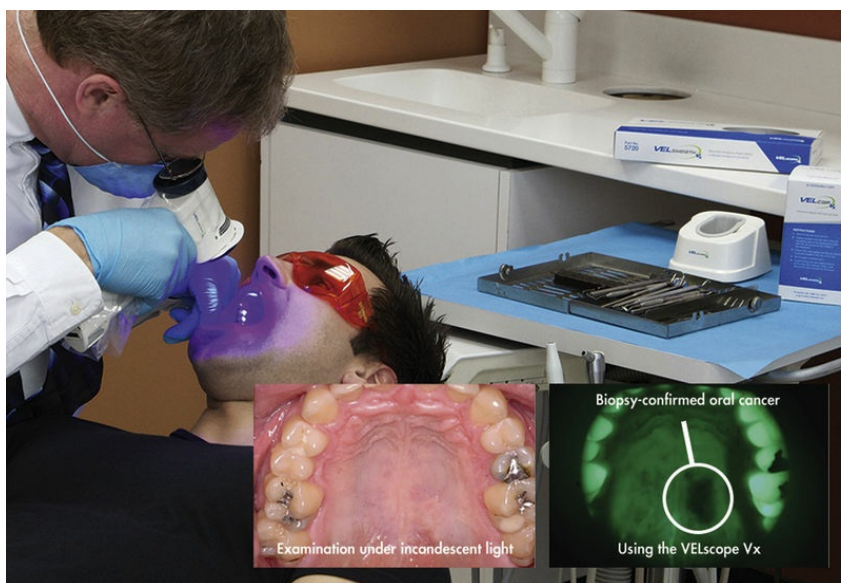

Instrument

Enhanced Oral Assessment System—VELscope Vx

Function

To aid in the assessment of oral mucosal abnormalities in early visualization of potential oral cancer, precancerous lesions or tissue, infections, and trauma that are not apparent to the naked eye alone

To use as an aid in determining surgical boundaries of oral lesions for excision

To use in conjunction with the traditional intraoral and extraoral examination. Referred to as the comprehensive oral exam (COE)

Characteristics

Technology is based on an imaging modality that is sensitive to tissue changes that illuminates oral cavity to visualize potential abnormalities.

Handheld device emits a harmless, ultraviolet (UV) light used to inspect the oral cavity. Device is sensitive to abnormal tissue changes. Distinctive blue-spectrum light causes the soft tissue (oral mucosa) of the mouth to naturally fluoresce.

Imaging adapter with iPod touch attaches to VELscope Vx eyepiece for clinical photographic documentation

Practice Note

Velscope Vx is implemented in general practice as well as periodontal and maxillofacial surgery practices.

Sterilization Notes

Protective barriers should be used on the device for each patient such as VELcap Vx and VELsheath Vx, which is recommended for each patient examination. Manufacturer's recommendation should be followed for precleaning and disinfecting the unit.

Vital Signs and Beyond



Instrument

Stethoscope

Functions

- To listen to pulse
- To listen to heartbeat
- To listen to systolic and diastolic pressure when taking blood pressure

Characteristics

- Ear pieces to hear pulse, and/or blood pressure
- Device to place on an artery to hear the sounds from the pulse, systolic and diastolic pressure
Usually, blood pressure is taken at the brachial artery in the arm.

Practice Notes

Stethoscope in dentistry is used in conjunction with blood pressure cuff to hear systolic and diastolic pressure.
Stethoscope is used before dental procedures to hear the pulse, and take blood pressure

Sterilization Notes

Stethoscope should be precleaned and disinfected according to the manufacturer's recommendation.





Instrument

Aneroid Blood Pressure Cuff—Sphygmomanometer

Functions

To place pressure on the arteries to hear the systolic and diastolic pressure of the arteries

To place around the part of the arm above the bend in the elbow

Characteristics

- Blood pressure cuff for the arm
 - Meter—Aneroid dial system (without liquid); the readout for systolic and diastolic blood pressure
 - Rubber bulb—Attached to cuff with rubber tubing
- Blood pressure cuff available in regular size, small size, and larger size cuffs to fit various arm sizes
Cuff size should fit properly to obtain accurate blood pressure readings.
Cuff is placed above the bend in the elbow above the brachial artery.

Practice Notes

Blood Pressure Cuff is used in conjunction with the stethoscope to hear the systolic and diastolic pressure at the brachial artery located at the inner side of the bend in the elbow.

Document blood pressure readings in patient's chart.

Sterilization Notes

Blood Pressure Cuff must be precleaned and disinfected according to the manufacturer's recommendation.





Instrument

Automatic Blood Pressure Monitor

Functions

- To measure blood pressure automatically
- To display the blood pressure readout on the screen
- To measure pulse rate automatically
- To display the pulse readout on the screen

Characteristics

- Blood pressure cuff
 - Readout screen for blood pressure and pulse rate
- Blood pressure cuff available in regular size, small size, and larger size cuffs to fit various arms
Correct cuff size important for accurate blood pressure readings
Data from past blood pressure information available on some monitors

Practice Notes

Automatic Blood Pressure Monitor is used before medical and dental procedures.
Document blood pressure readings in patient's chart.

Sterilization Notes

Blood Pressure Cuff must be precleaned and disinfected according to the manufacturer's recommendation.





Instrument

Electrocardiogram (EKG) Machine

Function

To measure the electrical activity of the heartbeat

Characteristics

EKG chest leads; self-adhesive pads with wires attached with electrodes for conductivity and placed in specific locations on the patient which are connected to the EKG machine
A read-out is displayed on the screen.

Practice Note

EKG Machine is used to monitor the patient's heartbeat usually during dental surgical procedures, during intravenous sedation in a dental office (mostly for oral surgeries), and for general anesthesia.

Sterilization Notes

Chest leads are single use only. Chest leads used on the patient are disposable and should be disposed of in garbage. Single use only. Disinfect unit according to manufacturer's recommendation.





Instrument

Pulse Oximeter

Functions

To measure the concentration of oxygen in the blood
To detect the pulse rate

Characteristics

- Monitor to display oxygen concentration in the blood and pulse rate
- Finger device that measures the oxygen concentration and pulse rate that sends information to the monitor

Practice Note

Pulse Oximetry used to monitor the patient's heart beat as well as oxygen concentration usually during dental surgical procedures, during intravenous sedation in a dental office, and for general anesthesia

Sterilization Notes

Pulse Oximetry should be precleaned and disinfected according to the manufacturer's recommendation.



Instrument

Capnograph

Functions

To measure carbon dioxide (CO₂) in exhaled breath
To monitor patient's ventilation

Characteristics

- Capnograph monitors patient ventilation, providing a breath by breath trend of respirations and an early warning system of impending respiratory crisis.
- Monitor displays patient carbon dioxide in exhaled breath. Capnography provides an immediate picture of patient condition.

Example

Holding your breath. Capnograph will show immediate apnea. Pulse oximetry is delayed for several minutes, and the pulse oximeter will show high saturation of oxygen for several minutes with holding your breath.

When a person hyperventilates, their CO₂ decreases.

Practice Note

Used in dental offices for patients who are sedated

Sterilization Notes

Capnograph should be precleaned and disinfected according to the manufacturer's recommendations.



Instrument

Automated External Defibrillator (AED)

Functions

To use for emergency situations when a person is unresponsive
To use when a person has no pulse and is not breathing

Characteristic

Place devices correctly on patient and wait for automated voice directions from AED to proceed.

Practice Notes

A provider should be trained healthcare provider basic life support along with using an AED.
Preventive maintenance is required for update of batteries.

Sterilization Notes

AED should be precleaned and disinfected according to the manufacturer's recommendations.



Index

Note: Page numbers followed by *f* indicate figures.

A

- Acorn burnishers, [212f–213f](#), [212–213](#)
- Acrylic bur, laboratory bur, [154f–155f](#), [154–155](#)
- Adhesive-removing pliers, [464f](#), [464–465](#)
- AED, *See* [Automated external defibrillator \(AED\)](#)
- Air abrasion unit and handpiece attachments, [104f](#), [104–105](#)
- Air polisher, [106f](#), [106–107](#)
- Air/water syringe, [78f](#)
 - with removable tip, [72f–73f](#), [72–73](#)
- Air/water syringe tip, [61–82](#)
- Alginator, [634f](#), [634–635](#)
- Amalgam, tray setup for, [228f](#), [229](#)
- Amalgam carrier, [206f–207f](#), [206–207](#)
 - micro retro, [326f](#), [326–327](#)
- Amalgam well, [204f–205f](#), [204–205](#)
- Amalgamator, [202f](#), [202–203](#)
- Analgesic tanks, [52f](#), [52–53](#)
- Anchor tooth, dental dam hole size for, [169](#)
- Aneroid blood pressure cuff, [724f–725f](#), [724–725](#)
- Anesthetic cartridges, [44f](#), [44–45](#), [46f](#)
- Anesthetics
 - color code system on, [46f](#), [47](#)
 - epinephrine in, [46f](#), [47](#)
 - tray setup for, [58f](#), [59](#)
 - vasoconstrictor in, [46f](#), [47](#)
- Angle former, [30f–31f](#), [30–31](#)
- Anterior clamp, for dental dam, [174f–175f](#), [174–175](#)
- Anterior forceps, mandibular, [564f–565f](#), [564–565](#)
- Anterior hoe, [515](#)
- Apex locator, endodontic, [304f](#), [304–305](#)
- Applicator, [234f–235f](#), [234–235](#)
- Aprons, lead, [678f–679f](#), [678–679](#)
- Arch-bending pliers, [434f](#), [434–435](#)

Arch impression trays
 disposable plastic perforated full, 628f, 628–629
 metal perforated full, 630f–631f, 630–631

Arch wires, 428f–429f, 428–429
 nickel titanium, 429
 Optiflex, 429
 stainless steel, 429

Area-specific curettes
 see under Curettes

Arkansas stones, 372f, 373

Articulating paper holder, 226f–227f, 226–227
 characteristics of, 227
 functions of, 227

Aspirating syringe, anesthetic, 38f–39f, 38–39

Assistant chair, 80f

Autoclave (saturated steam), 614f, 614–615
 STATIM G4 cassette, 616f, 616–617

Automated external defibrillator (AED), 734f–735f, 735

Automatic blood pressure monitor, 726f–727f, 726–727

Automatic film processor, 690f, 690–691
 parts of, 692f, 692–693

Automixer, 640f–641f, 640–641

B

Back-action hoe, 516f–517f, 516–517

Ball burnishers, 212f–213f, 212–213

Band pusher, 412f–413f, 412–413, 427

Band pusher/plugger with scaler, 414f, 414–415

Band remover, posterior, 460f–461f, 460–461

Band seater/bite stick, 416f, 416–417

Bands, *See* Matrix bands

Barnhart curette, 336f–337f, 337

Barrel, of syringe, 38f–39f

Basic tray setup, 10f, 11

Battery operated curing light, 242f–243f, 242–243

Battery-operated sharpening device, 374f, 374–375

Beavertail burnisher, 216f–217f, 216–217

Bending pliers, arch, 434f, 434–435

Beta titanium arch wire, 429

Bi-bevel chisel, 547

Binangle chisel, 28f–29f, 28–29

Biological monitors, for sterilizers, 606f, 606–607

Bird beak pliers, 440f–441f, 440–441

Bite block, 382f–383f, 383

Bite registration tray, 642f–643f, 642–643

Bite stick, wooden, 272f–273f, 272–273

Bite-wing tabs, 670f, 670–671

Blade scissors, short, 390f–391f, 390–391

Blades, scalpel handle with, 484f–485f, 484–485

Bleaching trays, 381–402, 400f

Blister packs, of anesthetic, 46f, 46–47

Block-out material, 387

Blood pressure cuff, aneroid, 724f–725f, 724–725

Bone file, 544f–545f, 544–545

Bow, of dental dam clamp, 172f, 173

Bracket placement card, 420f, 420–421

- for Damon self-ligating brackets with self-ligating, 454–455
- for GAC self-ligating brackets with self-ligating, 456–457

Bracket placement pliers

- anterior, 424f–425f, 424–425
- posterior, 422f, 422–423

Bracket remover, 462f, 462–463

Bracket table, for instrument tray, 78f, 79

Brackets

- metal, 419
- orthodontic, 418f–419f, 418–419
 - see also specific brackets*
 - cementing and bonding tray for, 472f, 472–473
 - tray setup for, 476f, 477

Brass wire separators, 408f–409f, 408–409

Bridge scissors, 262f–263f, 262–263

Broach, endodontic, 290f, 290–291

Buccal/lingual hoe, 514f, 514–515

Bur shanks, 118f, 118–119

Burnishers. *see* specific burnishers.

Burs, 116f–117f, 116–117

- see also* specific burs.

C

CAD/CA milling machine, 270f, 270–271

CAD/CAM machine, 268f, 268–269

Capnograph, 732f, 732–733

Cartridges
for anesthetics, 44f, 44–45, 46f

Carvers. *see* specific carvers.

Cassette, 594f, 594–595

Cassette wrap, 600f, 600–601

Castroviejo needle holder, 500f

Cementation, crown and bridge, 278f, 279

Central, maxillary and mandibular, dental dam hole size for, 169

Cephalometric X-rays, 712f, 712–713
imaging unit for, 714f, 714–715

Ceramic brackets, 416f, 419

Ceramic stones, 372f, 373

Cerec machine, 268f, 268–269

Chair
assistant, 80f, 81
ergonomically structured, 76f
operator, 80f, 81

Chair adjustment device, 76f

Cheek retractor, 498f, 498–499

Chisel. *see* specific chisels.

Chuck, types of, 84f–85f, 85

Clamp, for dental dam, 172f, 172–173
see also specific dental dam clamps.

Cleaning unit, ultrasonic, 612f, 612–613

Color coding system, 596f–597f, 596–597
on anesthetics, 46f, 47

Composite burnisher, 240f–241f, 240–241

Composite disc, 150f–151f, 150–151

Composite placement instrument, 238f–239f, 238–239

Composite procedure
class I, class II, and class V, 252f, 253
class III and class IV, 250f, 250–251

Computer-controlled local anesthetic delivery system, 50f–51f, 50–51

Computer screen, 76f

Concave mirrors, 3

Condenser, interproximal, 210f–211f, 210–211

Condenser (Plugger), 208f–209f, 208–209
smooth and serrated, 208f–209f, 208–209

Cone-beam three-dimensional (3D) imaging system, 716f, 716–717

Cone bur, inverted, 124f–125f, 124–125

Container, sharps, 610f, 610–611

Contouring pliers, [264f–265f](#), [264–265](#)

Contra-angle attachments, [90f](#), [91](#)
types of, [91](#)

Contra-angle handpiece attachment, slow-speed motor with, [90f–91f](#), [91](#)

Conventional chuck, [84f–85f](#), [85](#)

Coon pliers, [446f–447f](#), [446–447](#)

Cotton forceps (pliers), [6f–7f](#), [6–7](#)

Cotton roll holder, [382f–383f](#), [383](#)

Cotton rolls, [382f–383f](#), [383](#)

Crosscut
straight fissure bur, [130f–131f](#), [130–131](#)
tapered fissure bur, [132f–133f](#), [132–133](#)

Crown and bridge cementation, tray setup for, [278f](#), [279](#)

Crown and bridge preparation, tray setup for, [276f](#), [276–277](#)

Crown and bridge scissors, [262f–263f](#), [262–263](#)

Crown-removing forceps, provisional, [266f](#), [266–267](#)

Cryer 150 universal forceps, maxillary, [560f–561f](#), [560–561](#)

Cryer 151 universal forceps, mandibular, [562f–563f](#), [562–563](#)

Curette, area-specific, micro mini-five, [360f](#), [360–361](#)

Curette, Ratcliff, [336f–337f](#), [337](#)

Curette, surgical, [496f–497f](#), [496–497](#)

Curette, UC/Rule, [338f](#), [339](#)

Curettes, area-specific, anterior, [342f–343f](#), [342–343](#)

Curettes, area-specific, extended anterior, [346f](#), [346–347](#)

Curettes, area-specific, extended mini anterior, [350f](#), [350–351](#)

Curettes, area-specific, extended mini posterior, [352f](#), [352–353](#)

Curettes, area-specific, extended posterior, [348f](#), [348–349](#)

Curettes, area-specific, posterior, [344f–345f](#), [344–345](#)

Curettes, universal, [336f–338f](#), [336–337](#), [340f](#)
Langer, [340f](#), [340–341](#)

Curing device, light, [78f](#)

Curing light
electronic and battery operated, [242f–243f](#), [242–243](#)
protective shield for, [244f–245f](#), [244–245](#)

Curved sickle scaler, [358f](#), [358–359](#)

Cuspids, dental dam hole size for, [169](#)

Custom-fitted bleaching tray, [388f](#), [388–389](#)

Cutters for ligatures/wires, [450f–451f](#), [450–451](#)

D

Damon self-ligating brackets with self-ligating, bracket placement card for, [454f–455f](#), [454–455](#)

Defibrillator, automated external, 734f–735f

Dental assistant delivery system, 78f, 78–79

Dental dam, 162f–163f, 162–163
tray set up for, 186f, 187

Dental dam clamp, 172f, 172–173
see also specific dental dam clamps.

Dental dam forceps, 170f–171f, 170–171

Dental dam frames, 182f–183f, 182–183

Dental dam punch, 168f–169f, 168–169

Dental dam stamp, 164f, 164–165

Dental dam template, 166f, 166–167

Dental delivery system, 76f, 76–77

Dental stools, 80f, 81

Dental unit, 61–82, 112f, 113

Dental X-ray unit, 682f, 682–683

DIAGNOdent, 392f, 392–393

Diagnostic equipment, 663–720

Diagonal slot, of Tofflemire/matrix band retainer, 190f–191f, 191

Diamond bur. *see* specific diamond burs.

Diamond disc, laboratory bur, 156f–157f, 157

Digital imaging system, SCANX, 710f, 710–711

Digital intraoral X-ray unit, 706f, 706–707

Digital panoramic imaging unit, 714f, 714–715

Digital sensors
holder for, 700f, 700–701
Rinn XCP holders for, 704f–705f, 704–705

Discoïd-cleoid carver, 220f–221f, 220–221

Dispensing unit/indicator tape, 604f, 604–605

Disposables, 382f–383f, 382–383
see also specific disposables.

Distal end-cutting pliers, 442f–443f, 442–443

Distal gingival margin trimmer, 32f–33f, 32–33

Distal/mesial hoe, 514f, 514–515

Double-sided mirrors, 3

Dry Aid, 382f–383f, 383

Dry heat (rapid heat transfer) sterilizer, 620f, 621

Dry heat (static air) sterilizer, 618f, 618–619

Dycal instrument, *See* Liner applicator

E

EeZee-Grip film holder, 672f, 672–673, 700f, 700–701

EKG machine, *See* [Electrocardiogram \(EKG machine\)](#)

Elastic ligature ties, [445](#)

Elastic separating pliers, [406f–407f](#), [406–407](#)

Elastic separators, [404f–405f](#), [404–405](#)

Electric handpiece unit, and handpiece attachments, [100f](#), [100–101](#)

Electrocardiogram (EKG machine), [728f–729f](#), [728–729](#)

Electronic apex locator, [304f](#), [304–305](#)

Electronic operated curing light, [242f–243f](#), [242–243](#)

Elevators. *see* [specific elevators](#).

Enamel hatchet, [20f–21f](#), [20–21](#)

Enamel hoe, [22f–23f](#), [22–23](#)

Endodontic broach, [290f](#), [290–291](#)

Endodontic explorer, [286f–287f](#), [286–287](#)

Endodontic file

- Hedstrom type, [294f](#), [294–295](#)
- K type, [292f–293f](#), [292–293](#)

Endodontic irrigating syringe, [308f](#), [308–309](#)

Endodontic locking forceps (pliers), [288f–289f](#), [288–289](#)

Endodontic long-shank spoon excavator, [284f](#), [284–285](#)

Endodontic millimeter ruler, [302f–303f](#), [302–303](#)

Endodontic plugger, [320f–321f](#), [320–321](#)

Endodontic reamer, [296f](#), [296–297](#)

Endodontic spreader, [318f](#), [318–319](#)

Endodontic stand, [300f](#), [300–301](#)

Endodontic stoppers, [298f](#), [298–299](#)

Endosteal implant, [573](#)

Epinephrine, in local anesthetics, [46f](#), [47](#)

Evacuation devices, [61–82](#)

Evacuator tip

- high-volume (velocity), [62f–63f](#), [78f](#)
 - surgical, [70f–71f](#), [70–71](#)
- low-volume (velocity)
 - mandibular, [68f](#), [68–69](#)
 - saliva, [64f–65f](#), [64–65](#)
- plastic, [62f–63f](#), [63](#)
- stainless steel, [62f–63f](#), [63](#)

Examination gloves, [588f](#), [588–589](#)

Excavators, spoon, [34f–35f](#), [35](#)

Explorers, [4f–5f](#), [4–5](#)

- endodontic, [286f–287f](#), [286–287](#)

External defibrillator, automated, [734f–735f](#), [735](#)

External processing indicator, 62–63
Extraction, tray setup for
 of impacted mandibular molar, 576f, 576–577
 of maxillary right first molar, 574f–575f, 574–575
Extraction instruments, 527–580
 see also specific instruments.
Eye wear, protective, 586f–587f, 586–587

F

Facebow, 256f–257f, 256–257
Fiberoptic high-speed handpiece, 86f–87f, 86–87
File. *see specific files.*
Film duplicator, 696f, 696–697
Film holders
 EeZee-Grip, 672f, 672–673
 periapical, 672f, 672–673, 674f
 XCP, 676f, 676–677
Film processor, automatic, 690f, 690–691
 parts of, 692f, 692–693
Film rack, 686f–687f, 686–687
Filter system, of handpiece maintenance system, 108f, 109
Finger bar, syringe, 38f–39f
Finger device, 730f, 731
Finger grip, syringe, 38f–39f
Finishing bur, 134f–135f, 134–135
Finishing strip, 247f–249f, 248–249
Flame, diamond bur, 140f–141f, 140–141
Flat-end brush, 98f, 99
Flat-end cylinder, diamond bur, 138f–139f, 138–139
Flat-end taper, diamond bur, 136f–137f, 136–137
Fluoride trays, disposable, 384f–385f, 384–385
Football burnishers, 212f–213f, 212–213
Forceps
 see specific forceps.
Four-number instrument, 18f, 18–19
 examples of, 18–19
Friction grip bur, 91
Friction grip shank, 145, 147
Front surface mirrors, 3
Furcation probe, 512f–513f, 512–513
 millimeter-increment markings on, 513

G

- GAC self-ligating brackets with self-ligating instrument, bracket placement card for, [456f–457f](#), [456–457](#)
- Gates Glidden bur or drill, [306f–307f](#), [306–307](#)
- Gingival margin trimmer, mesial and distal, [32f–33f](#), [32–33](#)
- Gingival retraction cord instrument, [260f–261f](#), [260–261](#)
- Glasses, protective, [586f–587f](#), [586–587](#)
- Glick instrument, [322f](#), [322–323](#)
- Gloves. *see* specific gloves.
- Gold carving knife, [224f–225f](#), [224–225](#)
- Guide slots, of Tofflemire/matrix band retainer, [191](#)
- Gutta-percha, [312f–313f](#), [312–313](#)
- Gutta-percha warming unit, [316f–317f](#), [316–317](#)

H

- Halogen radiometers, [246f](#), [246–247](#)
- Handles, *See* [Instrument handles](#)
- Handpiece maintenance system, [108f](#), [108–109](#)
- Handpiece unit and attachment
 - electric, [100f](#), [100–101](#)
 - laser, [110f](#), [110–111](#)
 - slow-speed motor, [88f](#), [88–89](#)
 - surgical, [102f](#), [102–103](#)
- Handpieces
 - burs for, [115–160](#), [116f–117f](#)
 - acrylic, laboratory bur, [154f–155f](#), [154–155](#)
 - crosscut, [130f–133f](#), [130–131](#)
 - diamond disc, laboratory bur, [156f–157f](#), [156–157](#)
 - finishing, [134f–135f](#), [134–135](#)
 - flame, diamond bur, [140f–141f](#), [140–141](#)
 - flat-end cylinder, diamond bur, [138f–139f](#), [138–139](#)
 - flat-end taper, diamond bur, [136f–137f](#), [136–137](#)
 - inverted cone, [124f–125f](#), [124–125](#)
 - magnetic bur block with, [158f](#), [159](#)
 - pear-shaped, [122f–123f](#), [122–123](#)
 - plain cut, [126f–129f](#), [126–127](#)
 - round, [120f–121f](#), [120–121](#)
 - shanks, [118f](#), [118–119](#)
 - wheel, diamond bur, [142f–143f](#), [142–143](#)
 - high-speed, [84f–85f](#), [84–85](#)
 - fiberoptic, [86f–87f](#), [86–87](#)

- rotary attachments for, [115–160](#)
- slow-speed
 - disposable prophyl angle attachments for, [96–97](#), [97f–98f](#)
 - prophy, [93](#), [92f–93f](#)
 - prophy angle, [98f](#), [98–99](#)
 - rechargeable prophyl, [94–95](#), [96f](#)
- unit
 - electric, [100f](#), [100–101](#)
 - laser, [110f](#), [110–111](#)
 - surgical electric, [102f](#), [102–103](#)
- Harpoon, syringe, [38f–39f](#)
- Hatchet, enamel, [20f–21f](#), [20–21](#)
- Height-adjustable foot ring, [80f](#), [81](#)
- Hemostat, [492f](#), [492–493](#)
 - orthodontic, [448f–449f](#), [448–449](#)
 - characteristics of, [449](#)
 - function of, [449](#)
- High-speed handpiece, [84f–85f](#), [84–85](#)
 - fiberoptic, [86f–87f](#), [86–87](#)
- High-volume (velocity) evacuator (HVE) tip, [62f–63f](#), [62–63](#), [78f](#)
- High-volume (velocity) surgical evacuation tip, [70f–71f](#), [70–71](#)
- Hoe. *see* specific hoes.
 - posterior, [515](#)
- Holder, for digital sensor, [700f](#), [700–701](#)
- Holes, of dental dam clamp, [172f](#), [173](#)
- Hollenback and half-Hollenback carvers, [222f–223f](#), [222–223](#)
- How (or Howe) pliers, [430f–431f](#), [430–431](#)
- Hydrocolloid unit, reversible, [644f](#), [644–645](#)
- Hydrocolloid water-cooled impression trays and hose, reversible, [646f–647f](#), [646–647](#)
- Hygiene instruments, [335–380](#)
- Hygiene tray, [376f](#), [376–377](#)

I

- Imaging unit
 - for cephalometric X-rays, [714f](#), [714–715](#)
 - for panoramic X-rays, [714f](#), [714–715](#)
- Implant, [572f](#), [572–573](#)
 - endosteal, [573](#)
- Implant scaler, [354f–355f](#), [354–355](#)
- Implant system, [570f](#), [570–571](#)
- Impression trays

disposable plastic perforated full arch, [628f](#), [628–629](#)
disposable plastic perforated quadrant and anterior, [632f](#), [632–633](#)
India stones, [372f](#), [373](#)
Indicator tape and dispensing unit, sterilization, [604f](#), [604–605](#)
Instrument handles, [8f](#), [8–9](#)
Interdental file, [522f](#), [522–523](#)
Interdental knife, spear point, [520f](#), [520–521](#)
Internal processing indicator, [62–63](#)
Interproximal carving knife, [225](#)
Interproximal condenser, [210f–211f](#), [210–211](#)
Intraoral dental film, [664f–665f](#), [664–665](#)
 package of, [668f](#), [668–669](#)
 various sizes of, [666f](#), [666–667](#)
Intraoral sensors, for digital images, [698f](#), [698–699](#)
Inverted cone bur, [124f–125f](#), [124–125](#)
Invisalign clear aligners, [466f–467f](#), [466–467](#)
Irreversible hydrocolloid spatula, [626f–627f](#), [626–627](#)
Irrigating syringe, [308f](#), [308–309](#)
Isolite-dryfield illuminator, [66f–67f](#), [66–67](#)

J

Jarabak pliers, [436f–437f](#), [436–437](#)
Jaws, of dental dam clamp, [172f](#), [173](#)
Jenker, [48f–49f](#)

K

Knife. *see* specific knives.
 carving, *See* [Carvers](#)
Kobayashi ties, [445](#)

L

Laboratory bur
 acrylic, [154f–155f](#), [154–155](#)
 diamond disc, [156f–157f](#), [156–157](#)
Laboratory coat, [582f–583f](#), [582–583](#)
Laboratory knife, [654f](#), [654–655](#)
Laboratory spatula, [648f–649f](#), [648–649](#)
Langer universal curette, [340f](#), [340–341](#)
Laser handpiece unit and laser handpiece attachment, [110f](#), [110–111](#)
Latch type bur, of contra-angle attachments, [91](#)
Laterals, maxillary and mandibular, dental dam hole size for, [169](#)

Latex-free dental dam, 163
Lead aprons, 678f–679f, 678–679
LED radiometers, 246f, 246–247
Lentulo spiral, 314f–315f, 314–315
Ligature director, 452f–453f, 452–453
Ligature ties, 444f–445f, 444–445
Ligature-tying (Coon) pliers, 446f–447f, 446–447
Light, adjustable intensity, 76f, 77
Light curing device, 78f, 79
Liner applicator, 198f–199f, 198–199
Lingual/buccal hoe, 514f, 514–515
Lip retractor, 458f–459f, 458–459
Local anesthetic, *See* Anesthetics
Local anesthetic syringe, 38f–39f
 components of, 37–60
 tray setup for, 58f, 59
Loma Linda curette, 338f, 339
Long needle, 42f, 42–43
Long shank, 145, 147
Low-volume (velocity) mandibular evacuator, 68f, 68–69
Low-volume (velocity) saliva ejector tip, 64f–65f, 64–65, 78f
Luxating elevator, 530f, 530–531

M

Magnetic bur block, with burs, 158f, 159
Mallet, surgical, 548f–549f, 548–549
Mandibular anterior forceps, 564f–565f, 564–565
Mandibular clamp, universal, 180f, 180–181
Mandibular forceps No. 16, universal, 552f–553f, 552–553
Mandibular forceps No. 17, 554f–555f, 554–555
Mandibular root forceps, 568f–569f, 568–569
Mandibular trial crown remover, 275
Mandibular universal forceps-Cryer 151, 562f–563f, 562–563
Mandrel
 sandpaper disc, with screw-type and snap-on, 148f–149f, 148–149
 screw on, 146f, 146–147
 snap on, 144f, 144–145
Manual developing unit, 684f, 684–685
Matrix band retainer, 190f–191f, 190–191
Matrix band system, 194f, 194–195
Matrix bands, 192f–193f, 192–193

Matrix system, sectional, [232f–233f](#), [232–233](#)
Maxillary clamp, universal, [178f](#), [178–179](#)
Maxillary forceps, No.10S, universal, [550f–551f](#), [550–551](#)
Maxillary left forceps No. 88L, [558f–559f](#), [558–559](#)
Maxillary right forceps No. 88R, [556f–557f](#), [556–557](#)
Maxillary root forceps, [566f–567f](#), [566–567](#)
Maxillary trial crown remover, [275](#)
Maxillary universal forceps-Cryer 150, [560f–561f](#), [560–561](#)
McCall curette, [338f](#), [339](#)
Measurements, *See* [Periodontal probes](#)
Mesial/distal hoe, [514f](#), [514–515](#)
Mesial gingival margin trimmer, [32f–33f](#), [32–33](#)
Metal brackets, [419](#)
Metal composite instrument, [238f](#), [239](#)
Metal perforated full arch impression trays, [630f–631f](#), [630–631](#)
Meter, of sphygmomanometer, [724f](#), [725](#)
Micro retro amalgam carrier, [326f](#), [326–327](#)
Micro retro mouth mirror, [328f](#), [328–329](#)
Microbrush applicator, [234f](#), [235](#)
Millimeter-increment markings
 on furcation probe, [512f](#), [513](#)
 on periodontal probes, [510f–511f](#), [511](#)
Milling machine, CAD/CA, [270f](#), [270–271](#)
Mixing gun for dental impression material, [638f](#), [638–639](#)
Mixing pads, paper, [660f](#), [661](#)
Mixing unit, vacuum, [652f](#), [652–653](#)
Model trimmer, [656f–657f](#), [656–657](#)
Molar band, [193](#)
Molars, dental dam hole size for, [169](#)
Monitoring device, radiation, [680f](#), [680–681](#)
Mouth gag, [482f–483f](#), [482–483](#)
Mouth mirror, [2f–3f](#), [2–3](#), [328f](#), [328–329](#)
Mouth prop, [480f–481f](#), [480–481](#)

N

Needle cap holder, [48f–49f](#), [49](#)
Needle guard, [40f](#), [41](#), [42f](#), [43](#)
Needle holder, [500f–501f](#), [500–501](#)
Needle hub, [40f](#), [41](#), [42f](#), [43](#)
Needles
 suture, [502f–503f](#), [502–503](#)

syringe
 long, 42f, 42–43
 short, 40f, 40–41

Nickel titanium arch wire, 429

Nitrile utility gloves, 592f–593f, 592–593

Nitrous oxide, 52f, 52–53
 and oxygen flowmeter, 56f, 56–57
 characteristics of, 57
 function of, 57

Nitrous oxide nose mask, 54f–55f, 54–55
 tubing for, 55

Nitrous oxide sedation, 37–60

Nose mask, nitrous oxide, 54f–55f, 54–55
 tubing for, 55

O

One ring and arm positioning system, 702f, 702–703

Operator chair, 80f

Optiflex arch wire, 429

Oral assessment system, VELscope Vx, 718f, 719

Orban, 4f, 5

Orthodontic band with tubing and hook, 410f–411f, 410–411

Orthodontic bracket/band removal tray, 476f, 477

Orthodontic brackets, 418f–419f, 418–419
 cementing and bonding tray for, 472f, 472–473
 tray setup for, 476f, 477

Orthodontic cementing and bonding brackets, 472f, 472–473

Orthodontic (Shure) scaler, 426f–427f, 426–427

Orthodontic tooth separating, 470f, 470–471

Orthodontic tying-in arch wire, 474f, 474–475

Osseointegration, 573

Outer knob, of Tofflemire/matrix band retainer, 190f–191f, 191

Overgloves, 590f, 590–591

Oxygen flowmeter, 56f, 56–57

P

Package, of dental film, 668f, 668–669

Panoramic X-rays, 712f, 712–713
 imaging unit for, 714f, 714–715

Paper holder, articulating, 226f–227f, 226–227

Paper mixing pads, 660f, 661

Paper points, sterile absorbent, 310f–311f, 310–311

Parts box, for sterilization, 598f, 598–599

Pear-shaped bur, 122f–123f, 122–123

Perforated full arch impression trays, disposable plastic, 628f, 628–629

Perforated quadrant and anterior impression trays, disposable plastic, 632f, 632–633

Periapical film holder, 672f, 672–673, 674f

Periodontal instruments, 509–526

Periodontal knife, kidney shaped, 518f–519f, 518–519

Periodontal probes, 510f–511f, 510–511

- millimeter-increment markings on, 511

Periodontal surgical instruments, 509–526

Periodontal surgical tray setup, 524f, 525

Periosteal elevator, 494f–495f, 494–495

Periotomes, 532f, 532–533

Peso file, 324f–325f, 324–325

Picks, root-tip, 540f, 540–541

Pigtail, 4f

Piston rod, 38f–39f

Placement instrument, composite, 238f–239f, 238–239

Plastic composite instrument, 238f, 239

Plastic evacuator tip, 62f–63f, 63

Pliers. *see* specific pliers.

Plugger, endodontic, 320f–321f, 320–321

Polisher, air, 106f, 106–107

Portable unit, 708f, 708–709

Positioning system, one ring and arm, 702f, 702–703

Posterior hoe, 515

Power lever chuck, 84f–85f, 85

Power scaler, 362f–363f, 362–363

Preframed dental dam, 184f–185f, 184–185

Premolar band, 193

Premolar clamp, in dental dam, 176f, 176–177

Premolars, dental dam hole size for, 169

Preparation, crown and bridge, 276f, 276–277

Preventive and sealant instruments, 381–402, 398f

Probes

- furcation, 512f–513f, 512–513
- periodontal, 510f–511f, 510–511
 - millimeter-increment markings on, 511

Prongs, of dental dam clamp, 172f, 173

Prophy angle attachments, disposable

- prophy slow-speed handpiece/motor with, 92f–93f, 93
- for slow-speed handpiece/motor, 96–97, 96f–97f
- Prophy angle slow-speed handpiece/motor, 98f, 98–99
- Prophy brush, disposable, 97
- Prophy cup, 98f, 99
 - disposable, 97
 - disposable prophy angle attachment with, 96f, 97
- Prophy slow-speed handpiece/motor
 - with disposable prophy angle attachment, 93, 92f–93f
 - rechargeable, 94–95, 96f
- Prophylaxis polishing, tray setup for, 396f, 396–397
- Protective glasses, 586f–587f, 586–587
- Protective mask, 584f–585f, 584–585
- Protective shield, for curing light, 244f–245f, 244–245
- Provisional crown-removing forceps, 266f, 266–267
- Pulp tester, Vitalometer, 282f–283f, 282–283
- Pulse oximeter, 730f, 730–731
- Push-button chuck, 84f–85f, 85
- Push-button device, 90f, 91

R

- Radiation monitoring device, 680f, 680–681
- Radiometers, LED and halogen, 246f, 246–247
- Ratcliff curette, 336f–337f, 337
- Reamer, endodontic, 296f, 296–297
- Recapping device, 48f–49f, 48–49
- Rechargeable prophy slow-speed handpiece/motor, 94–95, 96f
- Removing forceps, provisional crown, 266f, 266–267
- Retainer, Tofflemire band, 190f–191f, 190–191
- Retraction cord instrument, gingival, 260f–261f, 260–261
- Retractor
 - lip, 458f–459f, 458–459
 - tongue and cheek, 498f, 498–499
- Reversible hydrocolloid unit, 644f, 644–645
- Reversible hydrocolloid water-cooled impression trays and hose, 646f–647f, 646–647
- Rheostat, for handpieces, 76f, 77
- Rinn XCP holders, for digital sensors, 704f–705f, 704–705
- Rongeurs, 542f–543f, 542–543
- Root elevators, 534f–535f, 534–535
- Root forceps
 - mandibular, 568f–569f, 568–569

maxillary, [566f–567f](#), [566–567](#)
Root planing, [378f](#), [379](#)
Root-tip elevator, [538f](#), [538–539](#)
Root-tip picks, [540f](#), [540–541](#)
Rotary attachments, for handpieces, [115–160](#)
Round bur, [120f–121f](#), [120–121](#)
Rubber bowl, flexible, [624f–625f](#), [624–625](#)
Rubber bulb, of sphygmomanometer, [724f](#), [725](#)
Rubber diaphragm, [44f](#), [45](#)
Rubber plunger, silicon, [44f](#), [45](#)
Rubber points, [152f–153f](#), [152–153](#)
Ruler, endodontic millimeter, [302f–303f](#), [302–303](#)

S

Safelight, [688f](#), [688–689](#)
Saliva ejectors, [78f](#), [79](#)
Sandpaper disc, with screw-type and snap-on mandrel, [148f–149f](#), [148–149](#)
Saturated steam, [614f](#), [614–615](#)
Scaler. *see* specific scalers.
Scalpel blade remover, [486f–487f](#), [486–487](#)
Scalpel handle with blades, [484f–485f](#), [484–485](#)
SCANX digital imaging system, [710f](#), [710–711](#)
Scissors. *see* specific scissors.
Screw on, mandrel, [146f](#), [146–147](#)
 sandpaper disc with, [148f–149f](#), [148–149](#)
Sealant, tray setup for, [398f](#), [398–399](#)
Sectional bands, [233](#)
Sectional matrix system, [232f–233f](#), [232–233](#)
Self-contained water unit, [74f](#), [74–75](#)
Sensors, intraoral, for digital images, [698f](#), [698–699](#)
Shade guides/digital color imaging, [258f](#), [258–259](#)
Shanks. *see* specific shanks.
Sharpening device, battery-operated, [374f](#), [374–375](#)
Sharpening stones, [372f–373f](#), [372–373](#)
Sharps container, [610f](#), [610–611](#)
Shepherd's hook, [4f](#)
Short blade scissors, [390f–391f](#), [390–391](#)
Short latch-type shank, [145](#), [147](#)
Short needle, [40f](#), [40–41](#)
Sickle scaler
 curved, [358f](#), [358–359](#)

- straight, 356f, 356–357
- Silicon rubber plunger, 44f, 45
- Single-bevel chisel, 547
- Sirona, 466f–467f, 466–467
- Slow-speed handpiece
 - with disposable prophylaxis angle attachment, 93, 96–97, 97f
 - prophylaxis, 93–94, 92f–93f
 - prophylaxis angle, 98f, 98–99
 - rechargeable prophylaxis, 94–95, 96f
- Slow-speed motor, 88f, 89
 - with contra-angle handpiece attachment, 90f–91f, 91
 - with straight handpiece attachment, 88f, 88–89
- Snap on, mandrel, 144f, 144–145
 - sandpaper disc with, 148f–149f, 148–149
- Spacer, 395
- Spatula
 - flexible alginate (irreversible hydrocolloid), 626f–627f, 626–627
 - flexible mixing, 658f–659f, 658–659
 - laboratory, 648f–649f, 648–649
- Spectra fluorescence caries detection aid system, 394f, 394–395
- Sphygmomanometer, 724f–725f, 724–725
- Spindle, of Tofflemire/matrix band retainer, 190f–191f, 191
- Spindle pin, of Tofflemire/matrix band retainer, 190f–191f, 191
- Spoon excavators, 34f–35f, 35
- Spore check, sterilization
 - in office, 608f, 608–609
- Spreader, endodontic, 318f, 318–319
- Spring separators, steel, 408f–409f, 408–409
- Stainless steel arch wires, 429
- Stainless steel evacuator tip, 62f–63f, 63
- Stand, endodontic, 300f, 300–301
- Start button, of handpiece maintenance system, 108f, 109
- Statim G4 cassette autoclave, 616f, 616–617
- Steel spring separators, 408f–409f, 408–409
- Sterilization, parts box for, 598f, 598–599
- Sterilization equipment, 581–622
 - see also specific equipment.*
- Sterilization pouches, 602f, 602–603
- Sterilization spore check
 - in office, 608f, 608–609
- Sterilizer

autoclave (saturated steam), 614f, 614–615
dry heat (rapid heat transfer), 620f, 621
dry heat (static air), 618f, 618–619
Stethoscope, 722f–723f, 722–723
Stones, sharpening, 372f–373f, 372–373
Stools, dental, 80f, 81
Stoppers, endodontic, 298f, 298–299
Straight chisel, 24f–25f, 24–25
Straight elevator, 528f–529f, 528–529
Straight fissure bur
 crosscut, 130f–131f, 130–131
 plain cut, 126f–127f, 126–127
Straight handpiece attachment, slow-speed motor with, 88f, 88–89
Straight sickle scaler, 356f, 356–357
Strip, finishing, 247f–249f, 248–249
Superfine diamond burs, 141, 143
Surgical chisel, 546f, 546–547
Surgical curette, 496f–497f, 496–497
Surgical electrical handpiece unit, and handpiece attachments, 102f, 102–103
Surgical evacuation tip, high-volume (velocity), 70f–71f, 70–71
Surgical mallet, 548f–549f, 548–549
Suture needle, sutures and, 502f–503f, 502–503
Suture removal, tray setup for, 578f, 579
Suture scissors, 504f–505f, 504–505
Svedopter (metal evacuator), 69
Syringes
 anesthetic aspirating, 38f–39f, 38–39
 irrigating, 308f, 308–309

T

T-ball burnisher, 214f–215f, 214–215
T-bar elevator, 536f, 536–537
Tanner carver, 218f–219f, 218–219
Tapered brush, disposable prophy angle attachment with, 96f, 97
Tapered-end brush, 98f, 99
Tapered fissure bur
 crosscut, 132f–133f, 132–133
 plain cut, 128f–129f, 128–129
Template, for dental dam, 166f, 166–167
Temporary anchorage device (TAD), 468f, 468–469
Threaded tip, syringes, 38f–39f

Three-number instrument, 16f, 16–17

Three-prong pliers, 438f–439f, 438–439

Three-way syringe, *See* Air/water syringe

Thumb ring, syringes, 38f–39f

Tissue forceps, 490f–491f, 490–491

Tissue scissors, 488f–489f, 488–489

Tofflemire band retainer, 190f–191f, 190–191

Tongue retractor, 498f, 498–499

Tooth opening, for endodontic therapy, 330–331
tray setup, 330f, 330–331

Tooth sealing, for endodontic therapy, 333
tray setup, 332f, 333

Torso support, adjustable, 80f, 81

Tray setups

- for amalgam, 228f, 229
- basic, 10f, 11
- for bleaching, 400f, 401
- for crown and bridge cementation, 278f, 279
- for dental dam, 186f, 187
- in dental delivery system, 76f, 77
- for endodontic tooth opening, 330f, 330–331
- for extraction
 - of impacted mandibular molar, 576f, 576–577
 - of maxillary right first molar, 574f–575f, 574–575
- for hygiene, 376f, 376–377
- for local anesthetic syringe, 58f, 59
- for orthodontic bracket/band removal, 476f, 477
- for orthodontic tooth separating, 470f, 470–471
- for orthodontic tying-in arch wire, 474f, 474–475
- periodontal surgical, 524f, 525
- for prophylaxis polishing, 396f, 396–397
- restorative
 - angle former used on, 31
 - binangle chisel used on, 29
 - enamel hatchet used on, 21
 - enamel hoe used on, 23
 - gingival margin trimmer used on, 33
 - spoon excavators used on, 35
 - straight chisel used on, 25
 - Wedelstaedt chisel used on, 27
- for root planing, 378f, 379

for sealant, 398f, 398–399
for sealing of tooth, 332f, 333
for suture removal, 578f, 579

Trays

bite registration, 642f–643f, 642–643
bleaching, 381–402
triple (disposable), 636f, 636–637

Trial crown remover, 274f–275f, 274–275

Trimmer. *see* specific trimmers.

Triple tray (disposable), 636f, 636–637

Tubing, for handpieces, 76f, 77

Tweed loop-forming pliers, 436f–437f, 436–437

U

UC/Rule curette, 338f, 339

Ultrasonic cleaning unit, 612f, 612–613

Ultrasonic scaler instrument tip

furcation, 368f, 368–369
subgingival, 366f, 366–367
supragingival, 364f, 364–365
universal, 370f, 370–371

Ultrasonic scaling unit, 362f–363f, 362–363

Universal band, 193

Universal curettes, 336f–338f, 336–337, 340f

Langer, 340f, 340–341

Universal mandibular clamp, 180f, 180–181

Universal mandibular forceps, No. 16, 552f–553f, 552–553

Universal mandibular forceps-Cryer 151, 562f–563f, 562–563

Universal maxillary clamp, 178f, 178–179

Universal maxillary forceps, No.10S, 550f–551f, 550–551

Universal maxillary forceps-Cryer 150, 560f–561f, 560–561

Universal surgical instrument, 479–508

Utility gloves, nitrile, 592f–593f, 592–593

V

Vacuum former, 386f–387f, 386–387

Vacuum mixing unit, 652f, 652–653

Vasoconstrictor, in local anesthetics, 46f, 47

VELscope Vx, 718f, 719

Vibrator for laboratory, 650f–651f, 650–651

View luminator, 694f–695f, 694–695

Vitalometer/pulp tester, [282f–283f](#), [282–283](#)

W

Wand/STA Single Tooth Anesthesia System, [50f–51f](#), [50–51](#)

Waterline treatment tablets, [74f](#), [74–75](#)

Wedelstaedt chisel, [26f–27f](#), [26–27](#)

Weingart utility pliers, [432f–433f](#), [432–433](#)

Well, for composite material, [236f–237f](#), [236–237](#)

Wheel, diamond bur, [142f–143f](#), [142–143](#)

Winged clamps, of dental dam clamp, [172f](#), [173](#)

Wire cutters, [450f–451f](#), [450–451](#)

Wire ligature ties, [445](#)

Wooden bite stick, [272f–273f](#), [272–273](#)

Wooden wedges, [196f–197f](#), [196–197](#)

Woodson instrument, [200f–201f](#), [200–201](#)

X

X-ray unit

dental, [682f](#), [682–683](#)

digital intraoral, [706f](#), [706–707](#)

X-rays

cephalometric, [712f](#), [712–713](#)

imaging unit for, [714f](#), [714–715](#)

extraoral, [712f](#), [712–713](#)

XCP film holders, [676f](#), [676–677](#)