

## **Advances in Mining Science and Technology**

Advisory Editor: B.N. Whittaker  
Mining Engineering Department, University of Nottingham  
Nottingham, Great Britain

---

- Volume 1 **Underground Mining Methods and Technology**  
(Szwilski and Richards, Editors)
- Volume 2 **Reclamation, Treatment and Utilization of Coal Mining Wastes**  
(Rainbow, Editor)
- Volume 3 **Design of Underground Hard-Coal Mines**  
(Paździora)

Advances in Mining Science and Technology, 3

# Design of Underground Hard-Coal Mines

**Józef Paździora**

Central Mining Institute, Katowice, Poland



ELSEVIER

Amsterdam—Oxford—New York—Tokyo

PWN—POLISH SCIENTIFIC PUBLISHERS

Warszawa

1988

Translated from the Polish by Mauriel Mierzyńska and Stanisław Bochniak

Distribution of this book is being handled by the following publishers:

For the U.S.A. and Canada  
ELSEVIER SCIENCE PUBLISHING CO., INC.  
52, Vanderbilt Avenue  
New York, NY 10017

For Albania, Bulgaria, Czechoslovakia, Cuba, German Democratic Republic, Hungary,  
Korean People's Democratic Republic, Mongolia, People's Republic of China, Poland,  
Romania, the U.S.S.R., Vietnam and Yugoslavia  
ARS POLONA  
Krakowskie Przedmieście 7  
00-068 Warszawa, Poland

For all remaining areas  
ELSEVIER SCIENCE PUBLISHERS  
25, Sara Burgerhartstraat  
P.O. Box 211, 1000 AE Amsterdam, The Netherlands

**Library of Congress Cataloging-in-Publication Data**

Paździora, Józef.

Design of underground hard-coal mines.

(Advances in mining science and technology; 3)

Translation of: Wybrane zagadnienia projektowania kopalń.

Bibliography: p.

1. Mining engineering. I. Title. II. Series.

TN145.P3513 1988 622'.334 87-27441

ISBN 0-444-98938-2 (Vol. 3)

ISBN 0-444-42846-1 (Series)

Copyright © by PWN—Polish Scientific Publishers—Warszawa 1988

All rights reserved.

No part of this publication may be reproduced, stored in retrieval system, or transmitted in any form or by any means, electronic, mechanical, photocopying, recording or otherwise, without the prior written permission of the copyright owner.

Printed in Poland

## **Preface**

The escalating worldwide demand for energy has had the effect, among other things, of promoting the development of coal mining. This development, on a world scale, has not been hampered either by the growing production of crude oil and natural gas or by the advances made in the last three decades by nuclear energy. Everything appears to indicate that coal's contribution in satisfying world energy requirements will be of signal importance for a long time yet. This is particularly true of those regions of the world, or of particular countries, where there are substantial reserves of this valuable fuel. The part played by coal in the world economy seems likely to be enhanced in view of the development prospects for methods of coal utilization, especially coal processing to obtain liquid and gaseous fuels.

These factors, coupled with the necessity of ensuring essential technical and economic effectiveness in mining investment projects have, over the last thirty years, resulted in increasing interest being shown by economists and theoretical and practical mining experts in plans for the exploitation of mining regions, and for the construction of new mines and the reconstruction of working mines. The major problems in this field were seen to be the technical and economic optimization of the project designs and raising the level of work safety in the mines. Thus mine design became a new area in mining sciences and also a specialist field in design theory. In some countries specialist design offices were set up, while in the universities and technical schools, students were trained as specialists in mine design and construction. Poland, a country having mining traditions stretching over many centuries, may be cited as an example. Thirty-five years ago the Chief Mine Design and Studies Office was organized here, followed a few years later by the Chief Coal Preparation Design and Studies Office, backed up by enterprises specializing in the implementation of mine investment projects, both underground and on the surface; meanwhile, institutes for mine design and construction were set up at the Academy of Mining and Metallurgy in Kraków and at the Silesian Polytechnic University in Gliwice. In the period from the end of World War II up to 1984, twenty new hard-coal mines, together with coal preparation

plants, were constructed in Poland, including mines with a daily production of 24 000 tonnes. Reconstruction and modernization projects have been carried out for more than 60 working hard-coal mines and preparation plants, while complex development of the new Rybnik Coal Region has been completed, complex development of the Lublin Coal Region is currently being implemented, and the development of the Upper Silesian Coal Basin is a continuing process. Working to Polish designs and with the active assistance of Polish mining experts, new mines and various mining facilities have been built or are in the course of construction in many foreign countries. Poland has gained a place in the forefront, not only as a coal producer and exporter, but also as an originator and exporter of technical mining know-how, particularly in the field of the design and construction of hard-coal mines.

My 25 years of practical experience in mine design, in the supervision of mining investment implementation both at home and abroad, and also in directing the activities of the Chief Mine Design and Studies Office in Poland, plus more than 20 years' teaching experience in the training of mining engineers, in particular as head of the Mine Design Department of the Mining Faculty at the Silesian Polytechnic University in Gliwice, prompted me to write this present book, which discusses the basic problems met with in the design of underground hard-coal mines. The book is not a classic textbook offering a collection of formulae for the calculation of specific physical values and giving precise principles for the selection of appropriate designs, magnitudes and technical parameters. All these may be found in specialist mining textbooks. My primary endeavour here has been to deal with all those questions in mine design which have not yet been answered in mining textbook publications and which, from my personal experience, I consider to be of importance. Pursuing this course, I have presented the general principles governing the design of new mines and the reconstruction of working mines, the development of mining regions, the design of coal-preparation plant, and energy economy in mines. Making use of the broad experience gained by the Polish mining industry in the implementation of mining investment projects, I have quoted several examples of technical and organizational solutions which effectively shorten the mine construction cycle. In many of the developing countries, difficulties are encountered in ensuring the regular supply of the materials, equipment and spare parts essential to maintain normal mine production. Bearing this problem in mind, I have put forward a conception for the organization of a stores-transport system for such conditions. Finally, I have given an account of the economics of mining investment.

I fully realize that the material given here by no means covers the whole

spectrum of mine design. I hope, however, that it proves of use to readers when taking investment decisions. The book is addressed chiefly to investors and engineers engaged in preparing plans for the development of mining regions, plans for the construction of new mines and the reconstruction of existing mines and preparation plants, and to students in the mining departments of technical schools and universities. I hope that the information offered here will be of genuine practical value, and moreover that it may stimulate the development of new ideas for design and implementation concepts.

I should like to express my thanks to the colleagues and co-workers who favoured me with their valuable help in preparing this book, and especially to Professor Mirosław Chudek, who reviewed it.

*Józef Paździora*

# Chapter 1

## Introduction

### 1.1 World Prospects for Hard-Coal Production Expansion

Coal mining, initiated in the 18th century for use in the ferrous and non-ferrous metals industries, shows a continuous dynamic development right up to the present day and most probably will do so well beyond the 21st century. The more than 100 years-old career of crude oil, which has revolutionized many technologies and sectors of industry, enabled significant developments in transport of all kinds and found a wide application as an energy and chemical raw material, has by no means eliminated coal from the global world energy balance. Neither has coal mining been appreciably affected by the growth of nuclear energy over the three decades of its existence or by the substantial increase in natural gas production.

Although both these energy sources play an increasingly important role they have not seriously challenged coal's share in meeting the escalating world energy demand. Furthermore, as no effective substitute for coking coal has yet been found, its production is essential for the metallurgical industry.

In the 'fifties and 'sixties certain circles in Western countries confidently prophesied the "twilight of coal". This prophecy was based on a belief in the infinite potential of nuclear energy and an uncritical fascination with the apparently unlimited availability and low price of crude oil on world markets at that time. The well-known political events of 1973, with their economic repercussions for importers of crude oil, forced a reappraisal of oil strategies and practical measures were taken to meet the crude-oil demand. As a consequence, the role and importance of coal took on a new look (or more precisely regained its "old" look) in the current and future world energy balance. The practical development prospects for nuclear energy give no support to the voices proclaiming the "twilight of coal". The need for rational expansion

of coal production is at present generally accepted and, although opinions may differ as to optimum projected growth of production, the necessity for such growth is no longer questioned.

The most reliable projections for the future of hard coal appear to be those found in the data presented by World Coal Study—WOCOL, which have been used to a certain extent in this book.

Factors favouring the expansion of coal production are both the growing demand for energy raw materials and the large coal reserves. Coal now takes second place after crude oil in supplying world requirements for energy raw materials. In 1977 world hard-coal production was about 2500 million tonnes and its share in the world energy balance was about 26%. At that time the share of the remaining energy raw materials and sources was as follows: crude oil—50%, natural gas—17%, hydroenergy—4.6% and nuclear energy—2.4%.

In 1981 world coal production was about 2800 million tonnes, of which some 40% was utilized in economically developed Western countries, 55% in the Socialist countries and about 5% in developing countries. Figures showed a clear increase in the share of coal and a marginal increase in that of hydro- and nuclear energy at the expense of crude oil and natural gas (no exact and reliable data available).

Long-term prognoses (up to the year 2000) foresee a considerable increase in the share of coal in meeting world energy needs and an appreciable decrease for the remaining energy raw materials and sources. Two variants of increase in coal demand are considered, i.e. moderate and large. It is estimated that assuming moderate increase in demand for coal, its share in meeting the increased world energy requirements in the year 2000 will be 37% and the corresponding figures for the remaining energy raw materials and sources will be: crude oil—10%, natural gas—8%, hydroenergy—13% and nuclear energy—32%. The large variant demand predicts an increase of 55% for coal assuming a reduction of 20% for crude oil and maintaining the increase of 32% for nuclear energy. Should nuclear energy's share drop by 10% then that of coal would increase to 67%. This means that in the year 2000 the share of hard coal in the world energy balance will be over 35% for moderate demand and 40% or even 43% for large demand.

Projections up to the year 2000 show an increase in hard coal consumption from about 2500 million tonnes in 1977 and about 2800 million tonnes in 1981 to 6000–7000 million tonnes. This increased demand for coal will take various forms in different parts of the world. For member countries of the Organization of Economic Cooperation and Development (Canada, USA, Denmark, Finland, France, FRG, Italy, Holland, Sweden, United Kingdom



and the remaining Western European countries, also Japan and Australia) demand for steam coal will rise from about 740 million tonnes in 1977 to about 1670 million tonnes (moderate variant) or about 2650 million tonnes (large variant) in the year 2000. As an example, figures are given for 1977 and 2000 (both variants) in million tonnes:

	1977	2000	
		moderate variant	large variant
Canada	18.0	67.0	106.0
USA	432.0	975.0	1590.0
Italy	2.4	19.5	48.5
Japan	10.0	64.0	132.0
Australia	29.7	124.0	149.0

Similarly, a two- or threefold overall increase in demand for coal (steam and coking) from the OECD countries is foreseen, i.e. an increase from about 990 million tonnes in 1977 and about 1180 million tonnes in 1981 to about 2000 million tonnes (moderate demand) or 3000 million tonnes (large demand) in the year 2000.

Countries outside OECD utilized about 1500 million tonnes of steam coal in 1977, the biggest consumers being: USSR (490 million tonnes), People's Republic of China (368 million tonnes), Poland (159 million tonnes), India (72 million tonnes), and South Africa (61 million tonnes). It is expected that the total demand for coal (steam and coking) for countries outside OECD will increase by the year 2000 to 3-4 thousand million tonnes and the corresponding figures for the developing countries will be: about 150 million tonnes in 1977 to about 600-700 million tonnes in the year 2000. In this period the People's Republic of China plans to reach an annual coal production of 1.5 thousand million tonnes while the figure for the Socialist countries is 1.5-2 thousand million tonnes. Poland plans to produce about 260 million tonnes of hard coal in the year 2000.

Table 1.1 shows world coal producers and level of coal production in the years 1977, 1981 and projected production for the year 2000 taking the large coal demand variant for the year 2000.

Bearing in mind the escalating world demand for energy, in a situation where alternative energy sources suffer from lack of availability, inadequate development or lack of technical/economic feasibility of production development, the substantial proved resources of coal and advanced technology speak clearly in favour of hard-coal production expansion.

TABLE 1.1 World hard-coal production

Country or region	Coal production, million t			% of world total		
	1977	1981	2000	1977	1981	2000
Canada	23	33.3	159	0.94	1.19	2.3
United States	560	697.4	1883	22.9	24.87	27.8
<b>Total North America</b>	<b>583</b>	<b>730.7</b>	<b>204.2</b>	<b>23.8</b>	<b>26.06</b>	<b>30.1</b>
Denmark	—	—	<1	—	—	<0.1
France	21	20.3	10	0.85	0.72	0.15
FRG	120	95.5	150	4.85	3.39	2.23
Italy	<1	<1	3	<0.1	<0.1	<0.1
Great Britain	108	127.4	162	4.37	4.53	2.4
Other western European countries	38	25.4	101	1.54	0.93	1.5
Japan	18	17.7	18	0.72	0.62	0.26
Australia	76	92.1	326	3.07	3.27	4.84
<b>Total OECD countries</b>	<b>964</b>	<b>1110.1</b>	<b>2813</b>	<b>39.0</b>	<b>39.47</b>	<b>41.84</b>
South Africa	73	131.2	228	2.95	4.66	3.39
India	72	121.1	285	2.91	4.30	4.23
Indonesia	<1	<1	20	<0.1	<0.1	0.29
Asian countries	15	68.3	11	0.6	2.42	0.16
Africa and Latin America	25	24.4	180	1	0.86	2.67
People's Republic of China	373	598.6	1450	15.1	21.28	21.57
Poland	186	163	260	7.53	5.79	3.86
USSR	510	544.2	1100	20.6	19.35	16.36
Other socialist countries	250	50	375	10.1	1.77	5.57
<b>World total</b>	<b>2469</b>	<b>2812</b>	<b>6722</b>	<b>100</b>	<b>100</b>	<b>100</b>

Table 1.2 gives world geological and industrial hard-coal reserves for the latter half of the seventies. The figures may be taken as approximately true also for the mid-eighties since losses due to extraction have no doubt been compensated for by the increase in reserves resulting from geological prospecting. According to the World Coal Study (WOCOL) total world hard-coal production in the period 1977–2000 will reach 103 thousand million tonnes, assuming large coal demand (variant two). This means that in this

TABLE 1.2 World hard-coal reserves

Country	Reserves, million t	
	geological	industrial
USSR	4 860 000	109 900
USA	2 570 398	166 950
People's Republic of China	1 438 045	98 883
Australia	600 000	32 800
Canada	323 036	4 242
FRG	246 800	34 419
Great Britain	190 000	45 000
Poland	139 750	59 600
India	81 019	12 427
South Africa	72 000	43 000
Other countries	229 164	55 711
World total	10 750 212	662 932

24 year period, based on figures for the second half of the seventies, about 15.5% of proved industrial reserves and 0.96% of geological reserves will have been extracted. These figures illustrate great prospects for the coal-mining industry, especially considering that as a result of current exploration geological and industrial reserves continue to rise. Of total estimated world coal reserves only about 6% is currently developed and exploited (in Poland about 30%).

It is worth noting that the ten countries listed in Table 1.2 have about 98% of world geological reserves and about 90% of industrial reserves, while the four countries with the richest reserves (USSR, USA, People's Republic of China and Canada) have about 90% of geological and about 60% of industrial coal reserves. The ten countries listed in Table 1.2 are also the leading world coal producers in the years 1977, 1981 and 2000, their production figures representing over 85% of world coal production. The largest reserves and the highest coal production is found in USSR, USA and People's Republic of China, their joint production in 1977 represented about 59% of world coal production and over 65% in the years 1981 and 2000.

Coal mining requires continuous investment efforts (development of new groups of seams) even to maintain current production at a stable level. It is clear that a planned increase in coal production calls for both investment projects in operating mines and the construction of new mines. The projected expansion of the coal mining industry offers important chances for design engineers, manufacturers of mining machinery and other equipment as well

as for investment construction enterprises. It should be stressed that these opportunities are not restricted to the countries possessing the largest reserves of coal and heading the list of coal producers listed in Table 1.2, but apply equally to the developing countries. Among some 50 developing countries with proved coal reserves, only 30 actually produce coal and their joint share in world coal production in 1977 was only 5% and shows no appreciable upward trend. However, interest in coal in these countries is growing. The countries of Africa and Latin America may serve as a good example, their coal production of about 25 million tonnes in the years 1977 and 1981 is planned to rise to about 180 million tonnes in the year 2000, i.e. an 8-fold increase. A growth of more than 20 times is planned in Indonesia. Hence it is obvious that the developing countries also have broad requirements for mining investment projects, if they are to meet future demands of further economic development.

Prospective development of coal production is not only dictated by the interests of the coal producers but it is also in a sense the moral obligation of coal-rich countries to export coal to countries with no reserves or insufficient reserves of this valuable raw material.

TABLE 1.3 World steam-coal imports

Country	Steam-coal imports, million t			
	1977	1981	2000	
			moderate demand	large demand
Denmark	4.6	10.9	9.4	20.9
Finland	4.1	*	7.7	12.4
France	14.0	17.3	26.0	100.0
FRG	3.0	10.1	20.0	40.0
Italy	2.0	7.7	16.5	45.5
Netherlands	1.5	4.7	19.9	34.2
Sweden	0.3	*	14.3	23.1
Great Britain	1.0	1.7	—	15.0
Other western European countries	7.0	13.3	32.0	42.0
Canada	6.0	9.5	8.0	4.0
Japan	2.0	12.6	53.0	121.0
Asian countries	—	*	60.0	179.0
Africa and Latin America	1.0	*	6.0	10.0
Socialist countries	17.0	*	30.0	30.0
World total	60.0	*	300.0	680.0

\*—no data available

Figures illustrating world steam and coking coal imports in the years 1977 and 1981 and planned import for 2000 are shown in Tables 1.3 and 1.4. Data from Table 1.3 indicate that in the 24-year period from 1977–2000 world imports of steam coal will increase 5-fold assuming moderate demand. Smaller, but also quite substantial increases will be seen in import of coking coal, rising from about 130 million tonnes in 1977 to about 260 or 300 million tonnes in the year 2000. Particularly big increases in import of this type of coal will take place in the Asian countries, Africa and Latin America.

TABLE 1.4 World coking coal imports

Country	Coking coal imports, million t			
	1977	1981	2000	
			moderate demand	large demand
Finland	0.9	*	1.0	1.0
France	10.0	10.2	12.0	15.0
FRG	1.0	0.7	—	—
Italy	11.1	10.8	12.0	12.0
Netherlands	3.0	3.2	2.9	4.0
Sweden	1.8	*	2.8	2.8
Great Britain	1.0	2.6	2.0	2.0
Other western European countries	6.0	18.6	24.0	32.0
Canada	7.0	5.4	9.0	5.0
Japan	60.0	65.3	79.0	85.0
Asian countries	3.0	*	40.0	48.0
Africa and Latin America	7.0	*	57.0	80.0
Socialist countries	18.0	*	20.0	20.0
World total	130.0	*	260.0	300.0

\*—no data available

According to the WOCOL prognosis the main coal exporters in the year 2000 will be USA (about 125–200 million tonnes), Australia (160), Republic of South Africa (55–75), USSR and Poland (each 50), Canada (27–47), People's Republic of China (30) and FRG (23–25 million tonnes). The United Kingdom, France, Belgium, India, Indonesia and other countries will also export about 25–50 million tonnes of coal per year around 2000.

One of the essential stimulators of hard coal production expansion is, and will continue to be, possible increase in export.

## 1.2 Coal Use

Due to competition from natural gas, crude oil and fissile fuels, coal's share in the world energy balance is decreasing, although the quantitative demand is increasing. Also the range of coal utilization is widening. Alongside conventional applications for energy production, the coking industry, the cement and brick industries, the chemical industry, the railways and domestic use, further possibilities for coal utilization for the production of liquid fuels (mainly petrol) and combustion gas, plastics and of many chemicals are foreseen.

Coal utilization processes may generally speaking be divided into traditional, i.e. well known, mastered and improved processes, and perspective processes still in the experimental stage.

Conventional coal utilization processes include:

- combustion
- gasification (incomplete combustion)
- degassing (low temperature carbonization, coking)
- production of moulded coke, smokeless fuels and also coal and graphite products.

Coal utilization processes still in the experimental stage include:

- non-conventional methods for energy production from coal
- production of liquid fuels from coal
- mild oxidation of coal
- other methods of direct chemical action on coal or application of physical means.

A separate problem linked with coal use is utilization of coal mineral waste (mine waste) and the mineral products of combustion, considered as useful raw materials.

Most of hard coal produced is utilized in a total combustion process in which the elements forming the organic coal mass, after reacting with atmospheric oxygen, pass into the following combinations: C into  $\text{CO}_2$ , H into  $\text{H}_2\text{O}$ , S into  $\text{SO}_2$  or  $\text{SO}_3$  and N passes into combustible gases in the form of molecular  $\text{N}_2$ . Coal mineral substance also undergoes transformations, passing into ash (slag fly ash), while aluminosilicates lose water of crystallization, carbonates pass into oxides while pyrite and marcasite pass into ferric oxides simultaneously emitting  $\text{SO}_2$ . Combustion of coal takes place in grate type (layer system) or pulverized fuel furnaces (chamber system). Fluidized bed combustion furnaces have certain properties of both these groups. Further development of coal-based thermal-power engineering will depend to a great

extent on the development of economic methods for combating atmospheric pollution by harmful chemical compounds, in particular sulphur dioxide.

Gasification of solid fuels represents a complex problem. In the simplest terms this process consists of the action of free or combined oxygen and hydrogen on the elementary carbon combined in the organic mass of the solid fuels. Gasification on an industrial scale takes place in reactors called *gas generators* or *gas producers*. They are of cylindrical or prism shape with rectangular cross-section and have equipment for delivery of fuel and gasifying medium and for taking off combustion gas generated and for ash and slag removal. Depending on the type of gasifying medium used, coal gasification produces the following technical gases: air gas, semi-water gas, water gas, water-oxygen-pressure gas and hydrogen gas. Many coal gasification methods are at present in very advanced stages of development, e.g. the HYGAS method based on fluidized coal hydrogenation together with steam-oxygen gasification of the solid residue, the BIGAS method consisting of two-stage pressurized gasification of fluidized coal with oxygen and water vapour or the CONSOL method based on coal gasification in the presence of calcinated dolomite as a constant heat carrier which also binds the CO<sub>2</sub> produced during the process. Noteworthy is underground coal gasification which takes place directly in the seam. Coal gasification processes should be considered as one of the most promising future trends in coal utilization.

In coal degassing the coal is heated to high temperatures (over 500°C) at which it decomposes into solid residue (semi-coke, coke) and volatile parts from which products such as liquid fractions (tar, benzols) and combustible gases are separated. Degassing involves three processes:

*1. Low temperature carbonization.* The purpose of this process (carried out at temperature 500–600°C) is the production of reactive smokeless fuel and motor fuels (Diesel oil and petrol).

*2. Gas production.* The aim is quantity production of combustible gas (town gas) of calorific value not less than 4200 kcal/m<sup>3</sup>. Additionally gas coke of low mechanical strength is produced and also gas pitch, benzols and gas liquor.

*3. High temperature carbonization.* This technology produces metallurgical coke, i.e. coke of high mechanical strength with low ash, sulphur and phosphorus content exhibiting good reactivity characteristics. Developments in standard high-temperature carbonization technology follow various lines: utilization of coal of low coking capacity, coal blending in order to equalize varying properties, improved grinding and blending of coking mixtures,

concentration of charge by drying or pre-heating, boosting capacity of coke oven batteries, speeding up the coking process, utilization of coke quenching heat, mechanical treatment of coke.

The primary aim of moulded-coke technology is the production of metallurgical coke from coal of low coking properties (steam coal or even brown coal). Environmental protection requirements led to the development of various technologies for producing smokeless fuels of low volatile parts content and producing virtually no smoke during combustion. Anthracite is a natural smokeless fuel and from industrial products also coarse grained coke and semi-coke. Tests are being made on high-temperature briquetting of quick coke from steam coal using sintered coal as the binding agent.

Electrode mixes, carbon electrodes and similar products are made from graphite and coal or coke. The technology employed includes plastic moulding, moulding from pulverized mixes or using casting methods.

Among the non-standard methods for obtaining energy from coal is the magnetohydrodynamic process during which electric current is generated as a result of the motion in a magnetic field of differentiated gases at high temperature and again the oxygen process in fuel cells in which oxidation of the fuel takes place at the negative electrode and oxygen reduction at the positive electrode. The summary reaction is equivalent to fuel combustion. Other non-standard methods of coal use are the combined method in which electrical and thermal energy is produced applying simultaneously several technologies, e.g. low temperature coal carbonization, combustion of semi-coke and of low temperature carbonization gases, use of primary tars, and direct combustion of coal slurry. After prior dewatering the slurry is piped to specially adapted furnaces and directly combusted using suitable burners.

The continuing expansion of the automotive industry has prompted interest in the search for an economic method of producing liquid fuels, particularly petrol, from coal. This is one of the future trends in coal use showing particular promise. Research is already advanced on extraction (peptization), hydrogenation of coal in a fluidized state in reactors and multistage pyrolysis of coal in a fluidized bed.

Research and experiments are in progress on mild oxidation of coal yielding humins, benzenocarboxylic and aliphatic acids for use in the chemical industry.

Among the methods of coal use which are still in the experimental stage hydrolysis, halogenation, sulphonation and quick pyrolysis of coal may be listed.

Developments may be expected in the production of plastics from coal by modification of its structure using chemical and physical methods and in binding reactions with various chemicals.



The brief account given here of currently applied technologies and future trends in coal utilization provides ample justification of the need for further development in this area.

### **1.3 Geological Conditions in which the most Important World Hard-Coal Deposits are found**

#### *1.3.1 Distribution of Hard-Coal Deposits throughout the World*

Deposits of hard coal may be found all over the world. The richest proved deposits occur in Europe (United Kingdom, FRG, Poland, USSR), Asia (USSR, People's Republic of China, India), North America (USA and Canada), Africa (Republic of South Africa) and Australia. Coal deposits of more modest size are also present in other countries. Many regions, especially in Africa and Latin America, have not been fully prospected.

Coals occur in three main systems:

- Carboniferous
- Permian-Jurassic
- Tertiary.

The zone of occurrence of Carboniferous coals stretches in a roughly E-W belt from the Kuznets and Karaganda basins through the Ural, Moscow and Donets basins in USSR to the Central and Western European coal basins including those of Great Britain and North America. These deposits are associated in the West with Hercynian orogenesis and in the Asian continent with somewhat delayed Altaic orogenesis. The coals occurring in this zone are classified as hard coals.

The zone of occurrence of Permian-Jurassic coals stretches in a belt along the eastern borders of Asia. The second branch includes Australia, India, Antarctica, South Africa and South America. The formation of the deposits in this zone is associated with the final phase of Altaic orogenesis. The coals in these deposits are mostly of hard-coal type.

The zone of Tertiary deposits is associated with Alpine orogenesis. The most important coal deposits of this zone are located on the western and eastern Pacific coast. This zone includes the east Asian Islands and Australia as well as the eastern borders of Asia and in the eastern Pacific the Tertiary deposits of North and South America. In Europe, Alpine orogenesis is principally associated with the broad regions of brown coal deposits in the German Democratic Republic and in Poland. Overall, in this zone only about 30% of the coals are of hard-coal type.

### 1.3.2 General Characteristics of Selected Hard-Coal Deposits

To discuss all the coal deposits in the world would be a large and intractable problem especially as many coal basins are as yet insufficiently explored. Hence discussion has been limited to the consideration of hard-coal deposits in the countries mentioned in Table 1.2 as having the largest coal deposits.

*1. Union of Soviet Socialist Republics.* The Soviet Union belongs to those countries most plentifully endowed with coal. Deposits are located in different parts of the country. From the geographical and economic aspects coal deposits are divided into two parts, European and Asiatic. The European part was industrialized much earlier and in consequence coal deposits in this part of USSR are better explored.

The coal deposits in USSR occur in various geological formations and six coal-bearing systems, starting with the oldest one, may be distinguished:

- Lower Carboniferous
- Mid and Upper Carboniferous
- Permian or Permian–Carboniferous
- Upper Triassic
- Mid Jurassic
- Cretaceous–Tertiary.

The Lower Carboniferous coal system includes the Karaganda, East and West Urals and Moscow basins. The Mid and Upper Carboniferous system includes the Donets basin and several smaller deposits located on the northern slopes of the Caucasus.

The richest deposits and the best quality coals are found in the Permian system (Permian–Carboniferous) including the Kuznets, Tungusk and Pechorsk–Kamsk deposits. About 50% of coal reserves in USSR is located in these deposits.

The Upper Triassic system includes the Cheliabinsk, Kazakh and Central Asian deposits.

The Mid Jurassic system includes several deposits in the Asiatic parts of the USSR, some of which have not yet been adequately prospected. The most widespread is the Irkuck basin where the coal-bearing formations cover an area of about 28 000 km<sup>2</sup>. This region is at present little explored.

The Cretaceous–Tertiary system covers the more important Central Asian deposits in the Chulom–Yenisei region.

The Karaganda basin with an area of 3000 km<sup>2</sup> is situated on the left bank of the river Nura. It has a syncline configuration with gently sloping northern flank and steep southern flank and is severely faulted. There are more than 50 seams of industrial value. Seam thickness varies from 0.6 m to 1.3 m

and only a few seams have a thickness of 5.0 to 8.0 m. The coals are mostly of coking type. The Triassic and Jurassic overburdens include brown coal deposits. The geological reserves of coal total some 51 thousand million tonnes.

The Moscow coal basin covers an area of 120 000 km<sup>2</sup>. The strata are little disturbed, the throw of known faults is not more than a few metres but the hydrogeological conditions in this basin are complicated. The coal-bearing formations are from 30 to 60 m thick and include four seams of industrial value. The thickness of these seams is from 1.5 to 2.3 m. Total coal reserves amount to about 24 thousand million tonnes. Although the Moscow deposit contains only brown coal it nevertheless plays a very important role in meeting the needs of local industry.

The Donets basin is the biggest coal deposit in the European part of the Soviet Union and has an area of about 60 thousand km<sup>2</sup>. The basin is of syncline type, the main tectonic feature being the so-called *main anticline* which passes through the whole of the coal basin. Several smaller troughs and synclines may also be distinguished. There are a number of faults of throws reaching up to 40 m and overthrusts of amplitude from a few up to 2000 m. The thickness of the productive formations, i.e. the Middle and Upper Carboniferous, is from 2400 to 2600 m. Total number of seams is about 200, of which 40 are currently suitable for mining. About 100 seams of thickness from 0.7 to 1.5 m are of industrial value. Only a few seams are as much as 2.5 m thick. Coal extraction is difficult due to the complex natural conditions in the deposit. Geological reserves to a depth of 2000 m are estimated at 241 thousand million tonnes.

The Kuznets coal basin of 26 000 km<sup>2</sup> area is a syncline with numerous breaks, faults and overthrusts. Many local troughs and anticlines are present. The thickness of the coal-bearing formations varies from 200 to 2300 m. In some parts these formations are interrupted by huge fields of basic extrusive rocks. The coal seams in the central sector of the basin have a fairly constant thickness, while those at the periphery vary considerably and some even disappear. Seam thickness is from 1.0 to 6.0 m. The quality of the coals is very varied, from brown coal to anthracite and graphite. Coal metamorphism increases with depth of seam deposition. The same applies to the methane content. Total reserves of coal are estimated at 905 thousand million tonnes and proved reserves at 66.9 thousand million tonnes.

**2. United States of America.** The coal deposits in the USA are associated with the Permian–Carboniferous, Upper Cretaceous and Tertiary systems. The coal basins of the Carboniferous and Permian series are found in the eastern

states (Appalachian and Pennsylvania basins) and in the middle west where the following coal basins may be mentioned: Northern (Michigan), Eastern (Illinois), Western and South-Western (Texas). The coal basins in the upper Cretaceous and Tertiary are in the Rocky Mountains region. The coal-bearing formations stretch from the Mexican border right through the USA and pass deep into Canada. The most important are the Carboniferous coal deposits due to their high quality and convenient location near the most industrialized eastern states of USA. Production from these eastern states accounts for about 69%, middle west 27% and from the Rocky Mountains region 4% of total hard-coal production in the USA.

The Appalachian coal basin, of area 180 000 km<sup>2</sup>, is in the eastern part of the USA. The productive Carboniferous is represented by two stages, the lower Mississippi and upper Pennsylvania. In the Mississippi stage only thin coal seams are present, in the Pennsylvania stage the most coal-bearing are the Allegheny, Monogahela and Pottsville series. A few seams occur in each of these series with thickness from 1.0 to 5.0 m and even up to 6.7 m. In the Permian formations is found the Dunkard coal-bearing series with two or three mineable seams. The most important is the Washington seam of thickness from 1.6 to 3.2 m. The Appalachian coal basin is a large synclinorium. Carboniferous deposits are folded and form a series of gently sloping anticlines and synclines in which the strata are almost horizontal.

Structurally the Pennsylvania coal basin is a north west extension of the Appalachian basin, from which it is separated by Devonian formations. The coal basin is in the form of a syncline with folded formations. Due to dynamic metamorphism anthracite seams have been formed which account for 95% of total anthracite production in the USA. They are utilized for power generation.

The Northern coal basin (Michigan) is located between lakes Michigan and Huron and occupies an area of 28 500 km<sup>2</sup>. The coal-bearing series appear in the Pennsylvanian formations and include seven seams of coking coal. Seam thickness varies from 1.0 to 3.0 m.

The Eastern coal basin (Illinois) covers the state of Illinois and partly the states of Indiana and Kentucky. Its area is 122 thousand km<sup>2</sup>. Pennsylvanian formations of thickness greater than 200 m occur here containing over 200 seams of steam and coking coal, of which seven are of uniform thickness and considerable extent. Seam thickness varies from 0.4 to 2.6 m. The shallow lying seams in the outcrops are mined in an opencast system.

The Western coal basin lies between the river Mississippi and its tributaries, the Missouri and Arkansas. Its area is 196 thousand km<sup>2</sup>. Pennsylvanian formations of thickness 900 m occur here, in which are 11 coal seams

of industrial importance. Seam thickness is from 0.9 to 2.6 m, and coal types from steam to coking coals are mined.

*3. People's Republic of China.* The Chinese coal deposits are chiefly associated with Carboniferous, Permian and Jurassic formations. The most favourable conditions for coal formation existed in the Upper Carboniferous. These deposits are found in the north east and north of China, while Permian period deposits are found in South China. The stratigraphy of many Chinese coal deposits is not yet sufficiently determined and the lack of geological proving of the coal deposits and their mode of occurrence means that estimates of coal reserves vary substantially. The largest coal deposits are the Fushun and Fushin in the north-east and the Szansi deposit in the north.

The Fushun deposit has been explored to a length of 30 km and a width of 4 km. The deposit is in the form of a trough with granite and gneiss bedrock. In the lower part of the Tertiary formations, which have a thickness of 240 m, are two coal seams. In the upper series a seam of thickness from 10 to 200 m, and overlying this seam are combustible shales of thickness 120–180 m. These shales are utilized as raw material for the production of liquid fuels. The coals are of hard-coal type or transitional from brown up to hard coals.

The Fushin deposit is in the form of a rift valley in which are two synclines cut up by numerous faults. The Upper Jurassic coal-bearing series of thickness more than 4000 m overlie crystalline formations. Seams of an aggregate thickness from 20 to 90 m are cut up by magma intrusions. This is the second most important deposit in China.

The Szansi coal basin covers an area of 157 thousand km<sup>2</sup> and its geological structure is comparatively well determined. Coal-bearing Carboniferous and Permian formations overlie the Cambrian and Ordovician bedrock. The largest deposit in this basin is the Datong with an area of about 2200 km<sup>2</sup>. The coal-bearing formations are in the Upper Carboniferous (Tazynan series), Lower Permian (Szansi series) and in the lower and Middle Jurassic (Datong and Jugan). The most productive are the Tazynan and Datong series. The structure of the deposit forms an asymmetric anticline. In the Tazynan three seams occur of thickness from 1.5 to 3.0 m, in the Datong are 30 seams of aggregate thickness from 12.5 to 26.0 m. The coal reserves of the Datong basin alone are evaluated at 100 thousand million tonnes.

*4. Australia.* The biggest coal basins are located along the eastern coast of Australia (Provinces of New South Wales, Queensland and Victoria). Deposits in the southern and western part of the country are of less importance. Four to eight hard-coal seams occur mainly in the Permian system, of thickness

greater than 2.0 m, locally reaching 7.0 m. Tertiary brown coals occurring in Victoria and South Australia are of signal importance.

The New South Wales coal basin is the largest in Australia and covers an area of 43 thousand km<sup>2</sup>. It consists of three parts: main (central), northern (Eschford) and southern (Reyvercen). Extensive coal-bearing formations occur in the Permian. In the lower series (Greta) are 2 to 7 seams with an aggregate thickness of 14 to 18 m of which the two most important are Upper Greta—of thickness 10 m and Lower Greta—up to 5.0 m thick. The upper formations include 5 to 11 seams with aggregate thickness of about 6 m. The depth of deposition of the coal-bearing formations is comparatively small, not exceeding 900 m.

The Dawson–Mackenzie coal basin (Great Syncline) is in the southern part of the State of Queensland and has an area of about 42 thousand km<sup>2</sup>. Structurally it is an asymmetric syncline with steep eastern flank and gently inclined western flank. In the middle and upper coal-bearing series are 4 to 6 seams of industrial importance of thickness from 0.9 to 7.0 m.

5. *Canada.* The Canadian deposits are the northern continuation of the US deposits and are found in Carboniferous formations located near the St. Lawrence river and in the Newfoundland Islands. The Sydney basin, where 40 seams of thickness 1.0 to 3.0 m and more rarely about 5.0 m are found, is the richest. About 9% of total Canadian coal production comes from this basin. The coal reserves are estimated at about 26 thousand million tonnes.

Coal-bearing formations also occur in the Cretaceous, the most important being located in the Alberta coal basin (Western Provinces). Structurally this deposit is a tectonic depression, the western part being folded while the eastern part forms a plateau flank. The most important coal-bearing formations are Kootenay and Lusear. In the Kootenay formations there are 5 to 22 industrial seams of thickness 1.0 to 15.0 m and even up to 45 m. The coal seams lie directly under the surface, and hence are extracted both by open cast and underground systems. In the Lusear formations are several seams. Two seams of thickness from 2.0 to 22.0 m are worked. Although the area of this coal deposit is extensive the complicated structure and mining difficulties have prevented wide scale exploitation. The Cretaceous deposits are of primary industrial importance, providing 55% of Canada's coal production, 50% from the Alberta basin alone.

6. *Federal Republic of Germany.* From the point of view of reserves, production and industrialization, the most important coal basin in FRG is the Westphalian, also called the Ruhr Basin, with an area of about 5 000 km<sup>2</sup>. The

Devonian bedrock is overlaid by Carboniferous. The Upper Carboniferous with a thickness of 300 to 600 m is the productive series. The overburden consists of Zechstein, Triassic, Jurassic, Cretaceous and Quaternary of aggregate thickness varying from a few to several hundred metres. Typical structure shows wide synclines and associated narrow anticlinal folds. In the coal-bearing formations about 130 seams have been proved of which 45 to 60 are of industrial value. Seam thickness varies from 0.5 to 2.8 m and the coal is of high quality coking type. Reserves to a depth of 1500 m are estimated at about 76.4 thousand million tonnes. Other smaller FRG coal deposits are found in the Aachen, Saar and Osnabrück basins.

7. *Great Britain.* The British coal deposits have for a long time been well explored and are concentrated in three sectors, the southern, central and northern areas.

The southern area includes the South Wales, Kent, Bristol and Somersetshire basins. These are of syncline form and the Carboniferous formations are folded and cut up by numerous faults. Seams of industrial value number from 12 to 26 and their thickness varies between 0.6 and 2.0 m and in sporadic cases up to 4.0 m. Coals are from gas to coking-coal type and anthracite is also found. The reserves are estimated at about 17 thousand million tonnes.

In the central area are the Yorkshire, Derby, Nottinghamshire and Lancashire basins, the strata sequence in all deposits being more or less the same. The Lower Carboniferous formations appear here in the form of thick limestone banks and the Upper Carboniferous are the productive formations. The number of industrial seams is from 24 to 42 with an average thickness of about 1.0 m. In certain cases seam thickness exceeds 2.0 m. The coal is of high quality and is classified between coking type and anthracite. Often the coal seams include intercalations of valuable sapropel. Total reserves are estimated at 16.5 thousand million tonnes.

The northern area includes the Durham, Northumberland and Scottish basins. All the series of the Carboniferous system have been developed here starting with Carboniferous limestone and ending with the coal-bearing formations. The basins are in the form of synclines which in the northern part pass into an anticline. Of the many coal seams 16 are fairly regular with average thickness not exceeding 1.5 m. Steam, gas and coking coals are found here and reserves are evaluated at about 5.1 thousand million tonnes. The Scottish coal basin on the other hand consists of small, isolated deposits formed after erosion of the Upper Carboniferous. The deposits are located in separate synclines. The number of seams reaches 25 and the thickness is from 1.5 to 2.0 m. Gas coals are found here while in the lower parts of the

Carboniferous are cannel and boghead coals. The reserves are evaluated at 3.3 thousand million tonnes.

8. *Poland.* There are three hard-coal basins in Poland, i.e. the Upper Silesian, Lower Silesian and Lublin Basins. In the first two basins coal has been mined for some decades while the Lublin Basin has been explored from 1960 onwards. The Lower Silesian coal basin, due to exhaustion of its reserves, has no future prospects. The largest and the most important is the Upper Silesian Coalfield where about 98% of the hard-coal produced in Poland is mined. The Lublin Mining Region has important development perspectives.

The Upper Silesian Coal Basin, of area about 4 500 km<sup>2</sup>, is situated in the south of Poland. Genetically it is a single formation with the Ostrava-Karvin Coalfield in Czechoslovakia. It is ranked as the second in Europe—both for area and reserves. The coal basin is in the form of a synclinorium. The productive Carboniferous has a thickness of up to 5 000 m and may be divided into three groups: littoral, anticline and syncline. In general it has been found that the thickness of these strata decreases towards the east. The number of seams in the western part is about 90 and in the eastern part about 50. The thickness of seams varies from 0.5 to 10.0 m and one seam is even 20 m thick. The two principal directions of tectonic disturbances are N-S and E-W. The geological reserves to a depth of 1 500 m are evaluated at 70 thousand million tonnes. Seams of steam, gas and coking coal are mined.

The Lublin coal basin in the south-eastern part of the country occupies an area of some 4 600 km<sup>2</sup>. The deposit is in the form of a belt some 180 km long and 20 to 40 km wide. The productive Carboniferous is overlaid by younger formations of thickness up to 800 m. The central part of the basin has been prospected and 24 seams of industrial value have been proved. Seam thickness is from 0.8 to 3.6 m. Coals are of steam coal type and reserves to a depth of 1 000 m are estimated at about 40 thousand million tonnes.

9. *India.* The most important coalfields are in the states of Bengal, Bihar, Orissa and Maharashtra. The chief deposits are in the Upper Carboniferous and the Lower Permian. Three series of coal-bearing formations may be distinguished, i.e. Talchir, Damuda and Panchet, which are covered by Triassic and Jurassic formations. The majority of the coal deposits are disturbed by numerous intrusions of extrusive rocks but the tectonic structure is comparatively straightforward. Coals are of poor quality and consequently India is short of coking coal. Coal reserves are estimated at 139 thousand million tonnes. The main coal deposits are Iharia and Ranigajjn.

The Iharia deposit is 270 km north-east of Calcutta and has an area of



about 450 km<sup>2</sup>. It is a syncline deposit dissected by volcanic intrusions. The best coal-bearing level is the Parakar with 18 to 25 coal seams of thickness from 2.0 to 3.6 m, four of them having a thickness of 8.4 to 15.0 m. The overall reserves to a depth of 600 m are estimated at 11 700 thousand million tonnes. About 40% of Indian coal production comes from this deposit.

The Ranigajn deposit ranks first in India for reserves and second in production. It is situated near the town of Asansol and has an area of about 1500 km<sup>2</sup>. The three coal-bearing series, i.e. Talchir, Damuda and Panchet overlie the Archaean formations. The Ranigajn level in the Damuda series is the richest in coal seams. Of the total of 20 coal seams in this deposit, 15 are found in this level. Coal reserves to a depth of 600 m are estimated at 13 thousand million tonnes and provide 30% of India's coal production.

*10. Republic of South Africa.* In the light of geological prospecting carried out up to now it would appear that the African continent has only small reserves of hard coal. These reserves are currently estimated at 213 thousand million tonnes and 92.6% of this is located in the Republic of South Africa and the rest in Zimbabwe (5.1%), Nigeria, Tanzania, Mozambique, Madagascar and other countries. The largest coal deposits in the Republic of South Africa are in the territories of the Transvaal, Natal, Orange Free State and Cape Province. The coal deposits are associated with the Karroo geological depression exhibiting characteristically zones of enormous north-south fractures. Coal formations are not folded but cut by vertical faults with large displacements. Coal-bearing formations are in the Permian and Triassic systems (Ekka and Beaufort series). In the Ekka series there are 6 coal seams of thickness varying from 2.0 to 4.0 m, one of the seams is 5.5 m thick.

Intensive volcanic action took place towards the end of the formation of the coal-bearing series. The coal seams in contact with the magma were subjected to coking. The coal is of average quality with high ash content but on the whole with no coking properties. The coal in contact with the extrusive rocks passes into mineable coke, semianthracite and anthracite.

## **Chapter 2**

### **Evaluation of Deposit Geological Conditions for Design Requirements**

#### **2.1 State of Deposit Exploration**

Before any major geological exploration of a mineral deposit or even small scale exploration (e.g. prior to shaft sinking) an exploration plan must be prepared.

Depending on the purpose of exploration and the consequent scope of drilling operations and basing on the available data on the geological structure of the given area, the number of boreholes, their depth and diameter, location and drilling method is fixed. The exploration plan also specifies the method of analysing rock samples and measuring water and gas inflow to the boreholes.

Although boreholes are sited after careful analysis of existing information on the geological structure of the region, this siting involves many random factors. The influence of a random factor increases in importance when the geological data is sparse or unreliable. Also the methods used for core analysis and for measurement of water and gas inflow carry certain errors inherent in the given method, while results may also vary depending on the skill of the operators and many other factors.

After implementing the exploration plan, frequently corrected during the drilling operations, current data on geological conditions, stratigraphy, water and gas inflow in various parts of the explored area is collated.

Analysis of exploration shows clearly that results obtained are only partially objective for various reasons, e.g. core recovery never reaches 100% and the properties of core sample rocks are changed due to the action of the drilling fluid and contact with the atmosphere. Water inflow may also be changed due to migration of drilling fluid to the rocks during drilling. Similarly,

measurement of initial gas-bearing properties of the rocks may be distorted by many factors.

The results of direct exploration provide a great deal of information but only on a certain number of points in the plan of the deposit. Location of these points is often governed by random factors and results obtained are not necessarily representative of the actual deposit sectors. Moreover, results obtained from tests carried out during the drilling operations or on drilling cores have only a certain range of accuracy. The same number of boreholes drilled within the same area but located at different points could produce quite different results. It is obvious that the denser the network of boreholes the greater is the probability of a reasonably accurate evaluation of the deposit.

All results of geological prospecting must be interpreted and from this interpretation the final geological documentation in the form of maps, graphs, tables and specifications is prepared. The greater the number of boreholes the greater the differences between the seam maps showing strata sequence and faults prepared by different people. It must be stressed that the tectonics plotted on the seam maps is only an interpretation and the same applies to the occurrence of water-bearing formations, variations in mineral quality, water salinity, gas content and other parameters. Nearly every new borehole or new test results make it necessary to update previous interpretations and may lead to considerable changes in conclusions.

Modern geophysical methods facilitate the preparation of geological documentation and increase the degree of reliability but they cannot clarify all doubts.

Thus the final opinion on deposit geological structure reached by the design engineer will be governed not only by careful study of available data, but to an equal extent by his own knowledge, experience, imagination and courage.

The design engineer often accepts the geological documentation as a correct picture, i.e. assumes faults and contour lines are plotted correctly, deposit variations and quantity of mineral reserves agree with figures given in the tables and the results of laboratory tests on rock strength and calculated inflows of water and gas correspond to the actual state of affairs. There are many examples of serious divergences between carefully prepared designs based on geological documentation and the actual conditions met with during mine development when this kind of approach has been used by the design engineer. Cases are known when a false evaluation of coal quality and of deposit tectonics resulted in difficulties in planned production development. In one of the new mines, as the deposit was cut up by development working and first production workings the *in situ* data made it necessary to modify

the tectonics maps again and again. This involved modifying the cutting out scheme and adapting it to the lines of the main faults as actually proved. During the time of cutting out the deposit the discovery of faulted zones meant that longwall panels had to be substantially shortened which limited the use of mechanization, hindering the progress of the extraction front. In another hard-coal mine, as two levels were being developed it was found that seam positions given in the geological maps were erroneous and the tectonic conditions determined during mining operations differed widely from those on the maps.

The designer may treat the geological documentation in two ways. He may accept that it reflects the real state of affairs and prepare the project designs based directly on the data provided. The degree of competence of the designs produced on this assumption is often inadequate and the results may be costly both during the time of construction and exploitation of the mine.

The second method is to accept the basic results produced by drilling and geological exploration with a certain reserve and to treat the geologists' and tectonics maps as auxiliary material. It is then the duty of the designer to select and develop a model for the mine the least vulnerable to probable inaccuracies in the geological documentation.

The more doubtful the geological data, the more flexible the mine mode should be.

## 2.2 Natural Conditions

Information on the strata overlying the deposit, i.e. the overburden and its hydrogeological regime, is of primary importance in establishing the natural conditions of the deposit. It is important to remember that the parameters of the overburden are the thickness of the strata and their physico-mechanical and hydrogeological properties.

First of all the following must be determined:

- the number, thickness and depth of occurrence of individual water-bearing strata
- the lithological nature of water-bearing strata
- hydrostatic and hydrodynamic pressures and filtration coefficient of the individual strata
- predicted inflow of water to the mine workings and the total inflow to the mine during the time of mine construction and deposit exploitation
- chemical composition of the water and its type.

When designing the shafts and the first ventilation level in the mining area

considered it is necessary to have a map on which the thickness of the overburden is indicated and a map of deposit roof series (Carboniferous or ore-bearing). These maps facilitate rational siting of shafts in the mining area and preliminary choice of suitable shaft sinking technology. It is essential to have a geomechanical description of the overburden formations, including the internal friction coefficients, the bulk density, slope and compaction coefficients for each layer. It is also necessary to identify the strata subject to swelling.

Knowledge of deposit tectonics and the sequence of deposition of the rock formations and the coal seams is of prime importance. Strata disturbances may be continuous, i.e. the layers may be deformed but not interrupted (folds) or may be interrupted and disrupted (faults). The designer should be acquainted with the basic elements of these disturbances, such as the line of the axis of the syncline or anticline and folds, angles of inclination of layers and seams, angle of inclination of fault planes, their azimuth and the vertical height of fault displacement. It is essential to know which faults, if any, are water-bearing and if they would constitute a water hazard for the mine workings (shafts, cross-cuts, development workings). This data forms the basis on which suitable methods for drivage of mine workings and for determining safety zones in the vicinity of faults are selected.

Knowledge of the vertical height of fault displacement is of importance in the planning of deposit development and for determining direction of extraction. Faults with vertical displacement of tens of metres (regional faults) divide the mine area into separate tectonic blocks. Faults of smaller displacement hamper development working and often require the use of special high strength yielding support. Small faults of throw up to 2 m present in great numbers may make full extraction mechanization impossible.

The thickness and slope of each seam must be determined as accurately as possible. The elements of the tectonic structure and disturbances of the strata should be included in the geological documentation. Geological maps showing seams deposition with seam floor or roof isolines marked on them facilitate the designers' task.

When designing new mines and new levels in existing mines the liability of the coal seams and the surrounding rocks to rock-bursts must be analysed for each seam or group of seams. It must be calculated using available data or by analogy with known seams and extraction conditions in neighbouring mines. There are many methods for evaluation of the natural coal liability to rock-bursts. In Poland the laboratory method where the energy index of coal liability to rock-bursts is determined is the most widely used.

Rocks liability to rock-bursts is governed by the petrographic structure (particularly of the coal itself) allowing the accumulation of elastic strain

energy and its abrupt release in a process of dynamic disintegration when limit strength is exceeded. The rock-burst hazard depends largely on the natural susceptibility to rock-bursts of the coal and rocks, and on the thickness of seams and the monolithic barren rock strata (the thicker the seams or rock layers the greater is the hazard). The depth of extraction on which depends the pressure of the rock body is also important. The rock pressure is influenced by variations in strata slope, faults and similar natural factors as well as seam remnants left unmined, existing extraction edges, the mutual effect of seams exploitation and other technical factors. The hazard is particularly large when the occurring stresses are close to the limit strength of the coal in the seam.

In different countries there are various requirements regulating the mining of seams in conditions of rock-burst hazard. Polish mining regulations and instructions for safe extraction of seams subject to rock-bursts distinguish three degrees of rock-burst hazard, specifying methods for determining the natural coal liability to rock-bursts and laying down the principles for the planning and execution of mining operations in seams classified in one of those three categories. In general, when planning the extraction of seams subject to rock-bursts it should be ensured that the deposit is completely mined out leaving no boundary, resistance or safety pillars or other unmined remnants in the seams. The number of roadways and other workings driven must be kept to a minimum. Only workings essential for development and production should be planned. Main development workings should be located, depending on the geological conditions, in barren rock strata, below the lowest seam endangered by rock-bursts or in a non-hazard seam. However, care must be taken that the planned extraction of this seam or series of seams will not increase the hazard in unmined neighbouring seams subject to rock-bursts.

In seams with higher degree of hazard (in Poland—II and III category seams) destressing extraction must be envisaged by working first the seam or strata in which rock-burst hazard is the least (destressing seam). Additionally, it is essential for extraction schedules to be synchronized both in time and space so that the destressing effect from mining out one seam gives maximum relief for each consecutive extracted seam in the given group.

The extraction of a destressing seam should be carried out in such a way that the relief zone extends to the neighbouring seams with higher rock-burst hazard.

Coal seams subject to rock-bursts should be mined using the longwall system, with the extraction front as long as possible and the length of longwall production sector not more than 5 to 8 m, depending on the type of roof

support and the method of roof control applied (roof caving, hydraulic stowing). For longwalls mined simultaneously in parallel, the longitudinal distance between longwall fronts should be either less than 10 m, or not less than 60 m. The sequence and direction of extraction of such seams should be scheduled so as not to increase the rock-burst hazard. Every care must be taken to avoid the longwall faces being taken close to old workings, roadways and faults.

When developing the model of the underground sector of the mine, it is very important to determine the natural inflow of water to the mine during both the construction and the normal production stages. The natural inflow includes water originating from both dynamic and static resources. The dynamic resources are usually fairly stable and originate from precipitation and surface water. Generally speaking, these inflows increase as development work continues.

The static resources consist of water accumulated in natural cavities in the rock body or the deposit, as well as in old goaves. These inflows gradually disappear as the resources become exhausted. Due to their varied origins and types, the dynamic and static water inflows should be calculated separately.

The most intensive water inflow takes place in the development stage, and gradually decreases in later stages. This is due to the exhaustion of static resources and to the fact that the drainage area remains the same throughout the period of mine development and normal production life.

Methods most frequently used for calculation of water inflows are:

- calculation based on the balance of water inflow to exploration boreholes
- calculation using theoretical formulae
- evaluation based on analogy with conditions in neighbouring mines.

In each case, however, a full set of geological, hydrogeological, meteorological, geomechanical and hydrographical data must be compiled.

When designing a new mine, the analogy method may be used only when the hydrogeological conditions in the analysed region are closely similar to those in the comparison region.

The degree of water inflow in the deposit in working mines is calculated by determining:

- watering coefficient  $k_w$ , expressing the ratio of quantity of water pumped out from the mine in unit of time to quantity of useful mineral produced in the same time unit, i.e.  $\text{m}^3$  of water per tonne of gotten,
- coefficient  $q_w$ , expressing water inflow relative to mine concession area ( $\text{m}^3/\text{km}^2$ ),
- coefficient expressing water inflow in unit of time ( $\text{m}^3/\text{min}$ ).

As an example Table 2.1 gives the volume of water inflow to operating mines in various coal basins.

The possibility of water or quicksand breaking into the mine workings in a quantity endangering the mine workers or the whole mining plant is called the *water hazard*. This hazard has to be taken into account during the stages in mine design, construction and deposit exploitation (Polish regulations specify three categories of water hazard in the mines). The analysis of hydrogeological conditions for a given deposit and the evaluation of accuracy of reserves estimation are carried out simultaneously.

TABLE 2.1 Water inflow to operating mines in various coal basins

Coal basin	Water inflow	
	m <sup>3</sup> /min	m <sup>3</sup> /t
Upper Silesian	0.3-24	0.4-32
Lower Silesian	0.6-12	1.8-10
Ruhr	—	1-20
Saar	—	2.8-3.5
Donets	—	2-3.5
Ural	3	3-5

The hydrogeological classification of deposits according to the 1967 recommendations of the Council for Mutual Economic Aid divides deposits into two groups, i.e. deposits with simple, and deposits with complicated hydrogeological conditions. Deposits with simple hydrogeological conditions have small water inflow (up to 10 m<sup>3</sup>/min) and no special dewatering method is needed during mining. Deposits with complicated hydrogeological conditions have considerable water inflow (above 10 m<sup>3</sup>/min) due to the presence of loose rocks or compact rocks with developed Karst features, cavitied or cut up by numerous water-bearing or quicksand-bearing faults. In such conditions it is necessary to apply safety measures (water dams) protecting against large water inflows or break-in of quicksand. Special methods for dewatering the deposit must be applied during mining operations.

### 2.3 Coal Quality

The quality of coal is specified by a number of parameters determined by laboratory methods. The most important parameters are:

- moisture content
- ash content



- volatile matter content
- heat of combustion and calorific value
- sulphur content
- caking power
- dilatometric indices
- true and apparent density
- free swelling index
- expansion pressure
- primary tar capacity
- carbon (C) and hydrogen content
- grinding capacity
- vitrinite light reflection ability
- phosphorus content in ash
- maceral group content
- porosity
- sorption capacity
- self-ignitability index.

Some knowledge of coal quality characteristics is indispensable at all stages of the mine design, as the methods and scope of coal dressing in the planned coal preparation plant, and the suitability of the coal product for specific technological processes have to be determined and a selling price (value of production) established. Coal quality is monitored during the whole period of mine operation to control (and adjust) the quality parameters of the commercial product. These and other requirements made development of coal classification necessary. Different countries use various principles for such a classification, in some countries standard specifications are in use. In Poland the basis for classification was developed by T. Laskowski and B. Roga, working on the assumption that classification principles should be as simple as possible and suitable not only for scientific and technical purposes but also for ordinary coal consumers. Classification parameters include rank, physical and chemical properties, and the parameters which most accurately determine coal's suitability for specific technological processes. The methods for determination of classification indices should be as simple as possible and easy to perform in practical production conditions. The time required for such determination should be short and the result should be repeatable.

The quality is determined by several parameters which, properly grouped, form the basis for the following classification (notation in brackets is the official Polish Standard Specification):

- classification of coal according to type (PN-82/G-97002)
- classification of coal according to grain size (PN-82/G-97001)

— classification of coal according to degree of cleanness and calorific value (PN-82/G-97002 and PN-82/G-97004).

Division of hard coal into types is based on its natural characteristics determining its suitability for technological utilization as defined by the following indexes:

- volatile matter content in the coal, converted for dry, ash-free substance
- caking power (Roga index)
- dilatation
- free swelling index
- combustion heat converted for dry, ash-free substance.

Hard-coal type in Poland is represented by a two-figure number: the first figure indicates the fuel type, and the second the coal rank. Its value marks volatile matter content, caking power and dilatation. An additional indicator expressing the combustion heat of steam coal, caking power of gas-steam coal, dilatation and free-swelling index of ortho-coking coal or volatile matter content of semi-coking coal, is the figure following the full stop after the basic symbol.

The Polish classification of coal according to the type and utilization is as follows:

1. Steam coal: 31.1 and 32.2. For power generation, for all types of furnaces.
2. Gas-steam coal: 32.1 and 32.2. As above.
3. Gas coal: 33. For power generation, for grate and pulverized fuel furnaces, for industrial boilers, gas plants and blends for the production of coke in coking plants.
4. Gas-coking coal: 34.1 and 34.2. For the production of coke in coking plants, for gas plants and gas-coking plants.
5. Ortho-coking coal: 36.1 and 35.2. For the production of coke in coking plants.
6. Meta-coking coal: 36. As in 5.
7. Semi-coking coal: 37.1 and 37.2. For blends for the production of coke in coking plants; may also be utilized for power generation in specially constructed furnaces and for production of smokeless fuel.
8. Lean coal: 38. As in 7.
9. Anthracite coal: 41. As in 7.
10. Anthracite: 42. For power generation in specially constructed furnaces and for the production of carbon electrodes.
11. Meta-anthracite: 43. As in 10.

Size grading of coal is based on the size of coal grains. Depending on the natural structure, winning methods, loading and transport systems and the

preparation processes, the coal becomes crushed into pieces of various sizes. A collection of grains of more or less the same size, lying within the limits of a sorting division, is called a *grade*. Polish Standard Specification PN-74/G-97001 distinguished 12 coal grades. For the time being basic grades (12) and combined grades are allowed in production and in commercial transactions. Different grades command different prices, the lowest price being for fine coal (steam coal fines and preparation plant slurry) and the highest for coarse coal.

The classification of coal according to degree of cleanness and calorific value, as applied in Poland, indicates their fuel value and enables the coal consumer to judge its suitability for specific purposes. Hence the division of coal into grades represents an industrial-commercial division. Division of hard coal for power generation into classes is based on:

- calorific value of coal as delivered to the consumer
- ash content in coal as delivered to the consumer.

The basic indicator of the coal class are two numbers of which:

- the first number consists of the two first figures of the lowest calorific value of coal as supplied to the consumer, as foreseen for this class of coal
- the second number indicates the highest value of ash content in coal as supplied to the consumer as foreseen for this type of coal.

An additional indicator, the highest total moisture content as foreseen for this class of coal, is used for fine coal.

## **Chapter 3**

### **General Principles of Mine Design**

#### **3.1 Development of Design Methods**

The design of mining plants has advanced considerably during the last 30 years and become a new branch of mining science. In Poland, mine design was initiated and developed after World War II both as an area of mining science and as a practical accomplishment, reaching high standards and high technical and economic effectiveness.

Design development in the Polish mining industry was prompted by the necessity of modernizing and extending the existing hard-coal mines after the end of World War II. It became imperative to design and construct new hard-coal mines especially for coking coal, on a scale dictated by the rapid industrial and economic growth of the new Poland.

Investment both in the operating and in newly constructed mines was then the basic condition governing the development of the Polish national economy. Implementation of the huge mining investment program required the creation of suitable design and construction facilities. A considerable amount of invaluable practical experience has been gained and the broad achievements both in the scientific and practical field have won Poland a leading place in world mining.

As practical mine design techniques were developed, efforts were focussed principally on three groups of problems:

- indicating the most appropriate investment schemes for the development of economically useful mineral deposits and programming the associated design and investment work
- optimization of basic design parameters for new and reconstructed mines to obtain maximum profitability for the given investment outlay

— execution of technical designs necessary to implement the investment projects.

These tasks could not be implemented without the formulation and development of a theory of mine design, which has a clearly defined area of research interests, has formed its own system of conceptions and utilizes its own scientific methods or those adopted from other research areas. Three fundamental sectors may be distinguished:

- long-term mining predictions, formulating a concept of the future of the mining industry, being at once the logical consequence and the continuation of current activities, taking into account the effect of current and future external influences
- programming for current mining requirements, consisting essentially of analysis, selection and qualification of aims plus determination of means and methods for their implementation; the chief instrument here is optimization of design scheme variants
- technical designing, resulting in the overall design and costing blue prints for a mining plant and its component elements.

One of the main tasks in the theory of mine design is to analyse the feasibility of new design methods, to justify the choice of the most suitable ones, and to determine their best application. All these methods are based on the practical use of various modelling techniques.

Graphical modelling, i.e. design by drawing is the most widely used. Graphical models can include: sketches, technical drawings (conceptual, construction and workshop drawings), architectural drawings and diagrams (e.g. flow sheets). Automated computer data processing systems with equipment for graphical communication have broadened the scope of designer-computer dialogue considerably. These systems have become of major importance in designing.

Physical design models are useful for developing construction and operational schemes for investment projects. Their main advantage is that they provide a clear and objective view of the proposed design, of particular importance when it consists of a number of elements, installations, etc. Physical models are used primarily to illustrate shape and structure, i.e. they are two-dimensional and three-dimensional. The two-dimensional models are built up using flat shapes representing various sections, components, installations, etc., on a suitable scale. These shapes are set out on a base corresponding to the actual design site. The two-dimensional models show the layout of facilities or component elements in one plane (e.g. the layout at the mine surface or location of machines and equipment in a fixed space).

Three-dimensional models are built up using block shapes (scaled down

models of the individual facilities) and are used for designing (or visualizing) the spatial layout of the components of the given system and of complete systems.

Physical models are also used, e.g.:

- for conducting tests and measurements (e.g. strata pressure, deformation of roof support, etc.)
- for visual illustration (in complicated geological conditions) of seam location in the deposit and deposit disturbances and for planning of mining operations
- for visual illustration of certain design conceptions relating to development of the mine surface, the underground sector, individual mine facilities or installations.

Finally, mathematical modelling is currently more and more frequently applied. Simulation and optimization models are particularly important. The latter may be divided into analytical, analytical-variant and variant models. Such models tend to the elimination of the abstract, and hence can simulate the true situation with considerable accuracy.

Four fundamental problems have to be solved by the scientists and practical mining engineers as regards specific deposits. These are:

- designing the complex development of a mining region
- determination of optimum size of a mine
- design of a rational mine model
- determination of optimum size of mine production and its optimum structure.

The practical solution of these problems for a given deposit produces an overall conception of deposit development.

Many years of study and research have been devoted to the search for theoretical and practical solutions to these problems. In the fifties and sixties analytical methods were developed. In Poland, the earliest work on optimization of mine size was carried out by Ajdukiewicz and Krupiński, later to be extended by Bromowicz and Jawień. Results achieved made it possible to optimize the size of mines of different types and in different geological conditions. Optimization of mine model parameters was also investigated in works by Parysiewicz, Krzanowski, Rutowski, Bromowicz and Jawień. In the late sixties and early seventies work was carried out at the Chief Mine Studies and Design Office in Katowice (Poland) to develop a complex mathematical model of a mine, taking full advantage of computer techniques for optimization of mine design.

Optimization models were produced in the form of large sets of logical-mathematical relations incorporated in prepared programs for computer

calculation. Hence the number of parameters to be optimized may be increased, natural deposit conditions may be simulated more accurately and optimization criteria have become more complete and convincing. Conclusions drawn from analysis of optimization models are of immediate practical value and provide the basis for objective design decisions.

## 3.2 Systems Modelling and System Design

### 3.2.1 General Principles

Modern engineering has to deal with increasing complexity and scale of the problems confronting the designer. Plans are often developed under the pressure of constant haste, while at the same time the complexity of technology means that quality demands are more stringent than ever. Researchers have attempted to determine a design methodology system which could provide the basis for effective development of optimum design solutions. For the past thirty years, systems engineering, sometimes called *systems technique*, has gained a significant status as a new area of modern science. This has resulted from the fact that it is necessary to design not only the technical facility itself, in all its complexity, but also to define a whole group of material and organizational conditions which govern its effective operation. It has become accepted that a system must be considered as a certain complex whole comprehending also a whole set of external conditions without which it could not exist. The justification for the system approach to the design process is two-fold:

- The majority of designs are so complex that they call for integration of all available knowledge, cutting across the boundaries of individual scientific disciplines.
- Defining complicated designs in terms of systems engineering allows them to be solved within the framework of the overall design conception.

In this formalism a system is taken to be a set of component elements linked by the mutually interdependent processes taking place in them, these processes being defined by the objectives and scope of the system. For each system a structure must be established; it is built up by identifying the constituent subsystems and determining the relationships between them and also between the system and its environment. Division of the system into subsystems depends on the design requirements and is based on their functional characteristics.

When the input and output elements of the subsystems are determined in the context of the ultimate objective of the whole system, each subsystem may

be considered independently in the design process, always bearing in mind that many of the relations between the input and output elements of the particular subsystems have a reciprocal feedback reaction.

### 3.2.2 *Systems Design*

The systems approach to design problems has three basic characteristic features:

- a complex solution of the system is sought
- the design approach is interdisciplinary
- modelling methods are applied, mainly mathematical modelling, to obtain optimum solutions.

A complex analysis of the whole system is necessary if its optimum size and structure are to be determined. Advances in design techniques, particularly calculation and optimization methods, facilitate such analysis, although a scrupulous complex analysis for optimization of the whole system is usually very difficult. Individual subsystems are therefore analysed successively and partial optima obtained. Their sum, however, need not necessarily be the optimum for the whole system, due to the feedback existing between subsystems. It is the duty of the designer to determine system size and operational parameters so that minimum or maximum values of selected system characteristics are obtained. The designer must correctly identify the individual subsystems taking into account the actual needs of the system production technology or the system design process. The correctly selected subsystems may then be carefully analysed and designed individually, again bearing in mind their mutual interdependence and feedback. Computers make this task considerably easier.

Having determined the input and output characteristics and the size and structure of the whole system, and of the individual subsystems, an optimum overall conception may be developed.

### 3.2.3 *Designing a Mine as a System*

The scale of the investment involved in the construction of a new mine, the variety of facilities and technological processes envisaged together with the mutual relations linking these elements, justifies treating the mine as a system. Between the individual elements of the production in a mine, or more generally, between the subsystems in the system, there are exact relationships and mutual feedback. Correct selection and coordinated operation of all these subsystems has a radical influence on the production and cost effectiveness of the system. In the case of a mine, natural deposit conditions are also important. These



conditions are not stable but vary both in time and space thus appreciably adding to the difficulties encountered in optimizing the size and structure of the system, i.e. the mine.

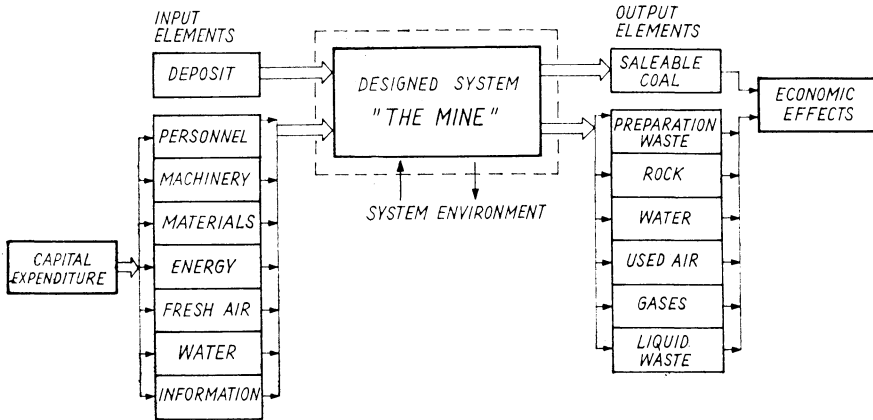

Fig. 3.1 Designed system "the mine". Transformation of input into output elements

Figure 3.1 gives a diagram of a mine system showing the transformation of input elements into output elements. The deposit of useful mineral represents the basic input element. To change this system from a static to a dynamic state additional input elements as indicated in Fig. 3.1 are necessary. The production taking place in the systems transforms these into output elements of which saleable coal is the main product and the remaining are either waste or by-products.

During coal extraction three basic subsystems may be distinguished:

- extraction of seams
- transport of the gotten
- coal preparation (Fig. 3.2).

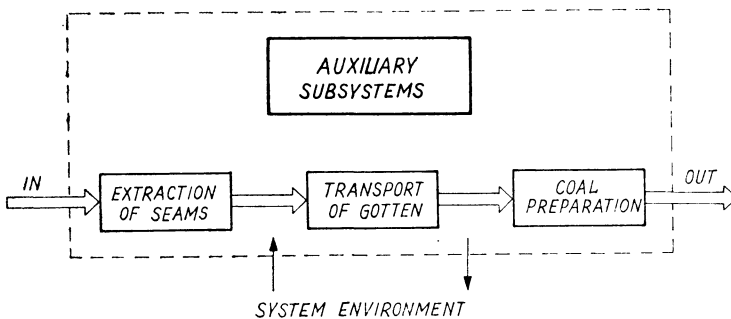

Fig. 3.2 Division of the designed system "the mine" into subsystems. (Elementary structure of the system.)

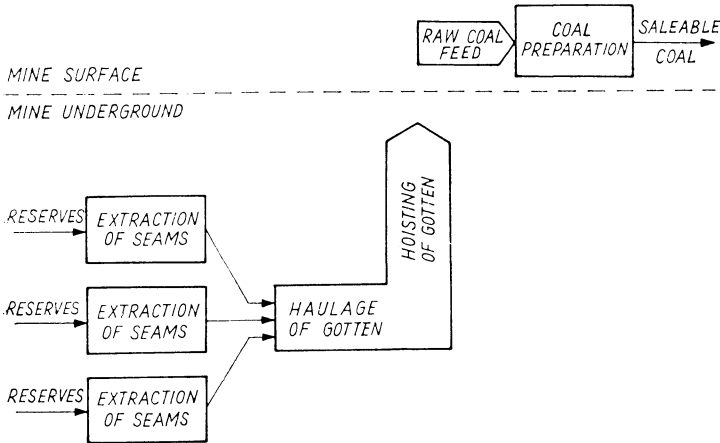

Fig. 3.3 Spatial arrangement of basic subsystems in the designed system "the mine".

The spatial arrangement of these three subsystems is illustrated in Fig. 3.3.

Figure 3.4 shows the division of the designed system "the mine" into subsystems according to production and non-production function. For produc-

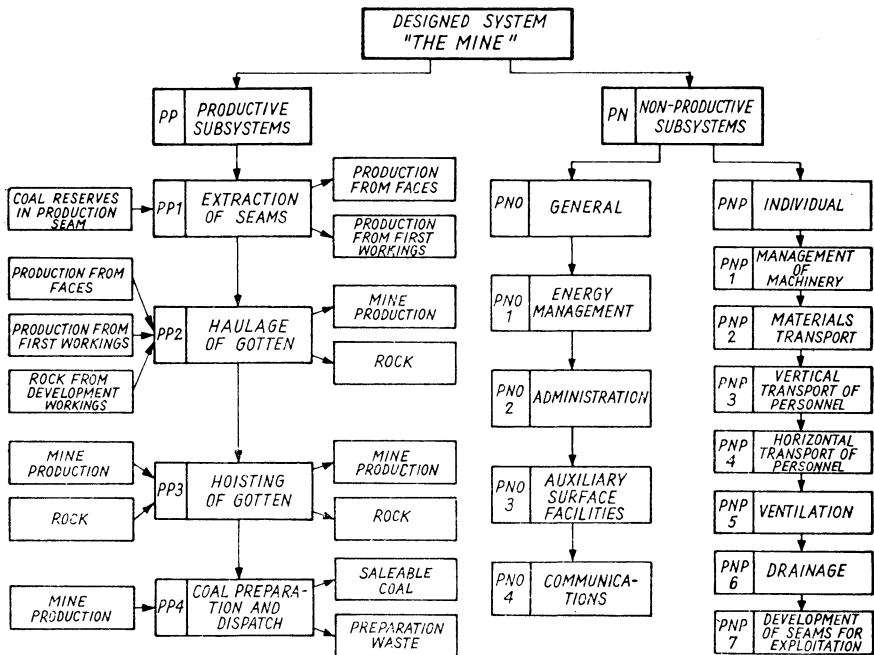

Fig. 3.4 Productive and non-productive subsystems in the designed system "the mine".

tion subsystems the basic input and output elements are indicated, leading from coal reserves in the seam to the saleable coal product. Non-production, or service subsystems, are designated as general duty, i.e. necessary to keep the whole system in operation, and individual subsystem duty, i.e. serving specific subsystems.

The arrangement of structural connections between the subsystems in the designed system “the mine” is illustrated in Fig. 3.5 (symbols are the same as in Fig. 3.4).

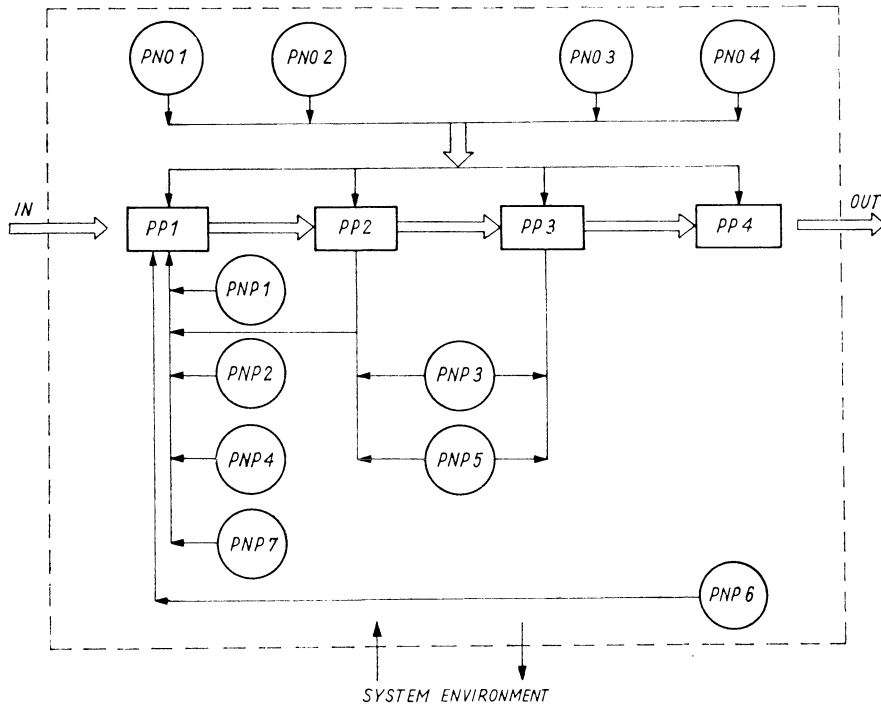

Fig. 3.5 Structural connections between the subsystems in the designed system “the mine”.

### 3.3 The Mine Model

The enormous capital investment expenditure for the development of a hard-coal deposit means that the decisions as to the size and model of the mine are of paramount importance and will have far-reaching consequences. Once the mine model has been designed and this design implemented, no appreciable changes should need to be made in the subsequent exploitation of the deposit.

This applies to the model of both the underground and surface sections of the mine. Any errors in location of shafts, in estimated depths of extraction levels or in the layout of the development workings, can be the cause of serious technological difficulties, excessive mineral losses and economic losses whose effects may persist throughout the life of an extraction level or of the mine. Similarly, mistakes made in siting the main surface facilities (preparation plant, railway sidings, pit baths, stores, main electric switchrooms, etc.) can cause technological and organizational difficulties.

The ultimate choice of the mine model is the most important step in finalizing the overall conception of mine design and in establishing the technical-economic principles. The reasons are as follows:

1. Execution of the underground section of the mine model, i.e. shaft sinking, driving development workings, excavation of rooms and auxiliary headings represents the most costly part of the venture and lasts longer than any other part of the mine.
2. The model of the underground section, once planned and implemented, does not change during the life of the level or the mine. The same applies to the mine surface model, which should retain its form throughout the life of the mine.
3. The development headings for opening up the deposit and the individual seams are the principal workings during the whole period of mine operation. They have a decisive influence on the organization and economic effectiveness of the technological process of coal winning.

The term “mine model” means the spatial location and interconnection of the basic mine components, i.e.: shafts, stone drifts, cross-cuts, extraction faces, development workings, pit bottoms and auxiliary facilities located underground, pit tops, coal preparation plant, railway sidings, stores, workshops and auxiliary facilities located on the surface.

Due to the diversity both in function and location of the component elements of the mine, the model is considered in two parts, i.e. (Fig. 3.6):

- model of mine underground section
- model of mine surface section.

### **3.4 Model of Mine Underground Section**

The *model of the mine underground section* denotes the spatial division of the deposit (within the mine concession area) into extraction and auxiliary levels and extraction panels, i.e. the overall layout of deposit development headings

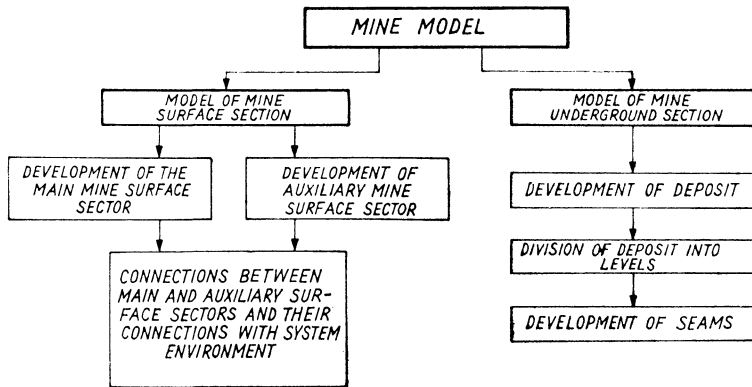

Fig. 3.6 Elements of the mine model.

and workings in the deposit and their mutual location relative to each other. The model of mine underground section is determined by the size and shape of the mining area, natural deposit conditions (number, mutual arrangement and slope of seams, disturbances), coal reserves and mining conditions (gassiness, rock-burst hazard, coal self-ignition liability, strata pressure, watering of overburden rocks, etc.).

The model of the mine underground section consists of (Figs. 3.6 and 3.7):

- development of the deposit
- division of the deposit into levels
- development of the seams.

Development of the deposit may be effected by means of vertical workings (vertical shafts), inclined workings (drifts) or horizontal workings (adits). In Poland deposits are normally developed using vertical shafts. Prior to the development operations the number and duty of the projected shafts must be decided as well as their location in the concession area.

Division of the deposit into levels involves the designation of extraction levels or determination of the vertical range of deposit exploitation.

Prior to this division the following must be established:

- vertical height of the levels
- depth (below ground level) of extraction and ventilation levels
- number of simultaneously operating levels (one- or two-level mine model)
- sequence of extraction schedule
- vertical range of deposit extraction in the case of a non-level mine underground model.

In seams development one of two basic structures, with many variants, may be used:

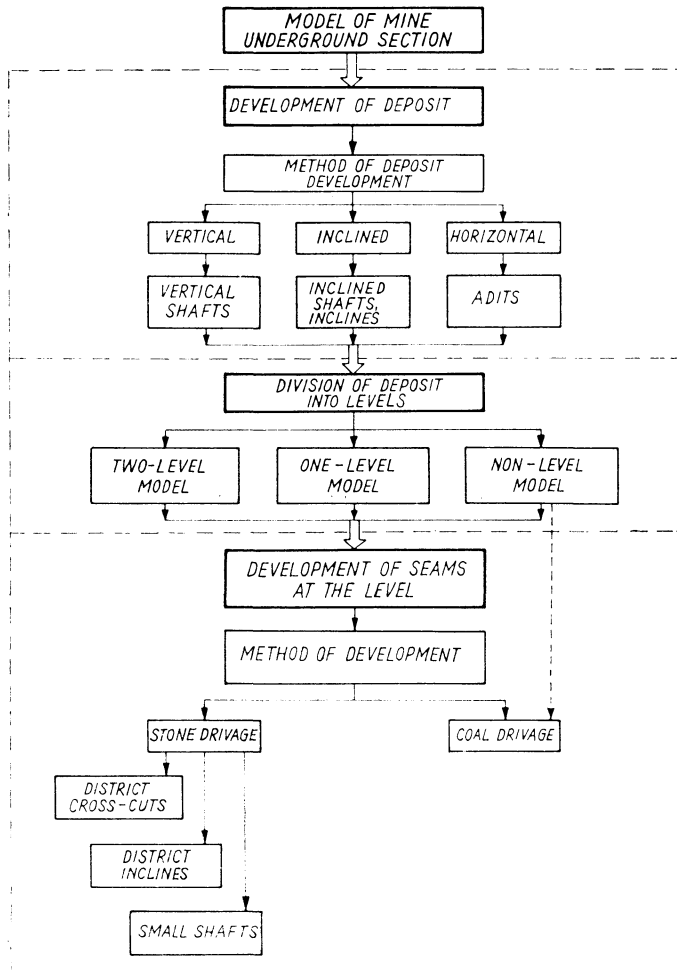

Fig. 3.7 Characteristic elements of the mine model underground section.

- *stone working structure* to gain access to the deposit (also called *geometric structure*)
- *coal working structure* to gain access to the deposit (also called *seam structure*).

Choice of seams development system, i.e. the ultimate layout of development workings, is dictated by the natural conditions in the seams.

### 3.4.1 Deposit Development using Vertical Shafts

The number of shafts to be sunk depends on two main factors:

- quantity of fresh air which must be delivered to the mine
- size of the mine concession area, which determines the length of ventilation roads.

The quantity of air to be delivered to the mine depends primarily on the target coal production per day, deposit gassiness, and depth of extraction.

The designs for new hard-coal mines may incorporate two, three, four or five shafts.

Deposit development by means of two shafts is used when the mine concession area and target production are not large. In this case the production shaft is the downcast shaft and the auxiliary shaft (for manriding/materials handling) is the upcast shaft. The decision to limit the number of shafts may be governed by the high costs of shaft sinking, especially in difficult natural conditions.

When three shafts are used two of these are upcast shafts, one of which is located at the periphery of the concession area due to the size of this area and the consequent length of ventilation roads. The diameters of the two upcast shafts are usually smaller than that of the downcast shaft (production shaft). If for some reason the diameters of all the shafts are similar, the ventilation capacities of the upcast shafts are not fully utilized. The design of new mines usually calls for four shafts (two downcast and two upcast) of approximately equal diameters. This kind of arrangement is applied when ventilation demand is high, e.g. for gassy mines with production up to about 12 000 tonnes per day and for non-gassy mines of about 24 000 tonnes per day. Most often three shafts (of which one is an upcast) are located at the main mine surface and the fourth is a peripheral shaft. In some cases where the take area is very large, and hence the length of ventilation roads is considerable, it may be necessary to use five shafts, of which three are upcast, two of them in peripheral locations. Mines with more than five shafts are very seldom found.

In designs prepared in recent years virtually only large diameter shafts are envisaged (7.5 and 8.0 m dia.).

### 3.4.2 *Division of the Deposit into Levels*

Figure 3.8 shows the division of reserves into the corresponding levels. On the  $Y$ -axis are marked the deposition depths and on the  $X$ -axis the mineable reserves divided into coal types. Knowledge of the quantity of reserves at the individual depths is necessary to prepare this diagram.

Values of the following parameters are shown in the diagram: vertical height of the levels  $H_p$ , service life of the levels  $T_p$ , mineable reserves  $Z_{op}$ . These parameters and estimated daily production from the level  $W_p$  are related by the indicator formula:

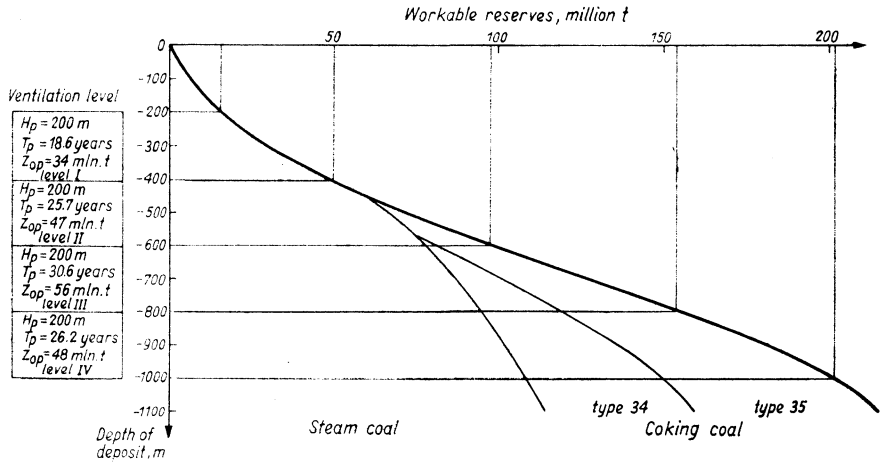

Fig. 3.8 Depth reserves diagram.

$$H_p = \frac{0.1 R_d T_p W_p}{Z_{uz} P} \quad (3.1)$$

or

$$H_p = \frac{0.1 R_d T_p \varphi}{Z_{uz}} \quad (3.2)$$

where:

 $R_d$  — number of working days per year $Z_{uz}$  — index of useful capacity of deposit, t/100 m<sup>3</sup> of Carboniferous $P$  — mine concession area, km<sup>2</sup> $\varphi$  — index of extraction rate,  $\frac{\text{thous. tonnes}}{\text{km}^2 \cdot \text{day}}$ .

Knowing the values of  $R_d$ ,  $T_p$  and  $W_p$  the required mineable reserves (million tonnes) are:

$$Z_{op} = R_d T_p W_p 10^{-3}. \quad (3.3)$$

The mineable reserves, and the index of useful capacity of deposit  $Z_{uz}$ , are related by the formula

$$Z_{uz} = \frac{1000 Z_{op}}{P H_p}. \quad (3.4)$$

The mineable reserves of a level  $Z_{op}$  (million tonnes) when its vertical height  $H_p$  and the index of effective deposit resources  $Z_{uz}$  are known, may be calculated from the formula

$$Z_{op} = 0.01 Z_{uz} H_p P. \quad (3.5)$$



For hard-coal mines in the Polish Upper Silesian Coalfield the following average values are found:

- $H_p = 120-200$  m,
- $T_p = 15-30$  years (in some cases more),
- $Z_{op} = 30-70$  million tonnes,
- $W_p = 4\ 000-12\ 000$  tonnes per day.

3.4.3 Seams Development at a Level

Seam development at a level may be effected by driving through the rock (stone workings) or through the deposit. Both methods may be used in the same mine.

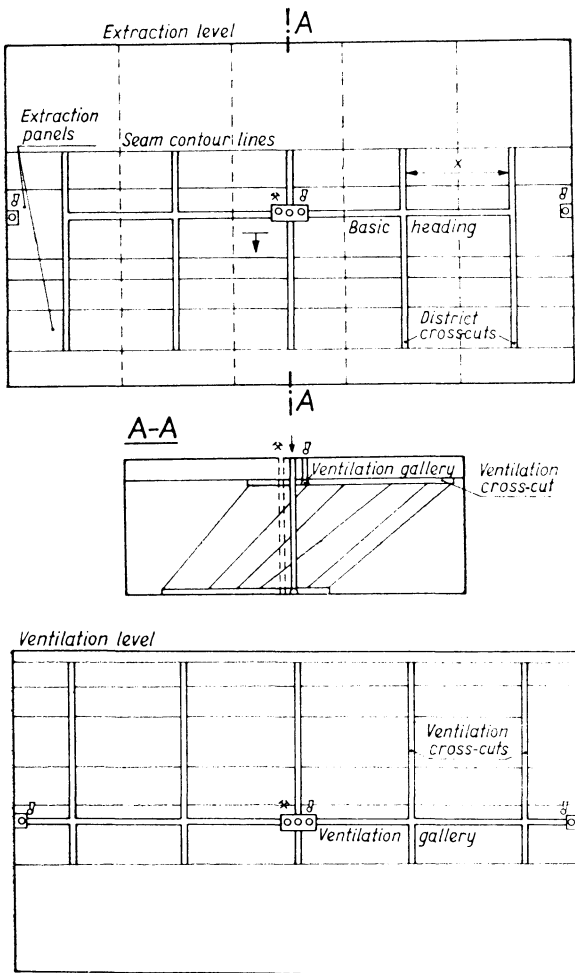

Fig. 3.9 Stone drivage deposit panelling. Group of seams developed by cross-cuts.

When the mine model envisages development drivage in the rock (stone drivage), the deposit is cut away from the main shafts. The main heading is driven parallel to the line of strike and perpendicular cross-cuts open up the seam or seams in the form of consecutive panels (Fig. 3.9). Alternately, the seams are opened using panel drifts. These inclined drifts are driven from the main heading or from short cross-cuts and are used for opening up new sections of the seams of small slope (Fig. 3.10). When the deposit has seams with a slight slope, small shafts may be used to give access to the seams. They

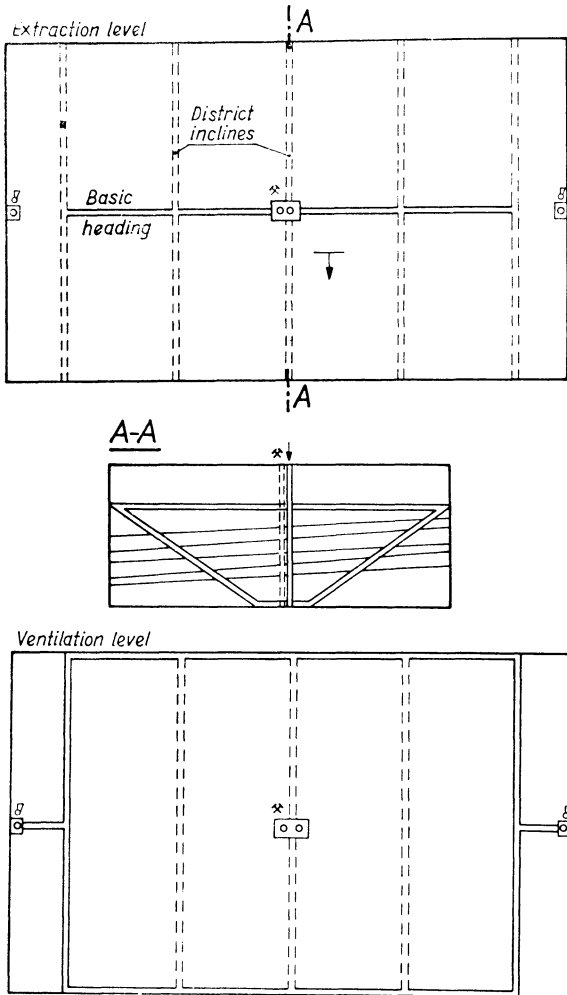

Fig. 3.10 Stone drivage deposit panelling. Group of seams developed by inclines..

are cut from the main cross-cuts and enable higher lying seams to be mined (Fig. 3.11).

The mine model with development workings driven in the deposit has a characteristic layout in which a principal cross-cut is driven from the main shaft perpendicular to the line of strike (Fig. 3.12). From this cross-cut the successive seams are opened up, driving the basic headings.

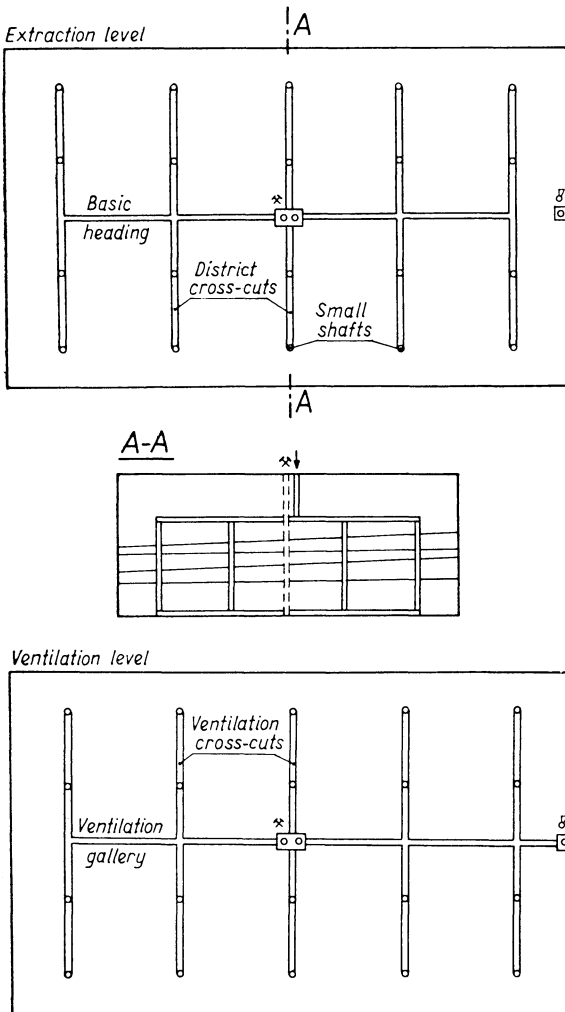

Fig. 3.11 Stone drivage deposit panelling. Group of seams developed by small shafts.

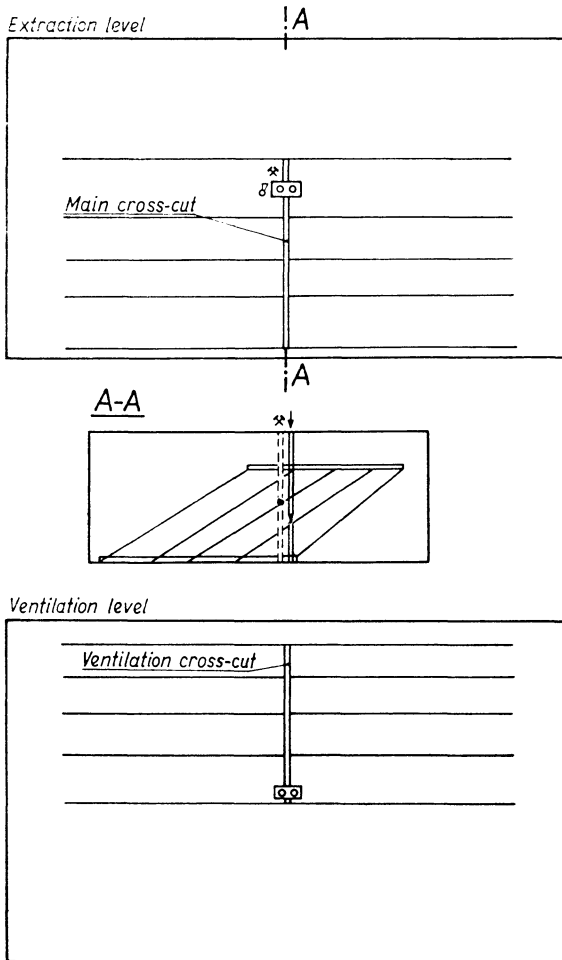

Fig. 3.12 Coal drifage deposit panelling.

### 3.5 Elements of the Mine Technological Process and their Interrelations

The elements linked directly with the production in a mine, from extraction to loading of dressed coal to the rail cars, are the most important. Generally, these elements form a series system, and hence their production capacities should be the same. The production capacity is the daily production, i.e. hourly production multiplied by a scheduled number of working hours per day of a given sector.

The most straightforward technological system would be one in which all the elements of the technological process have the same hourly production capacity and the same synchronized working time. Working times of production sectors differ, though, and cannot be synchronized. In addition, some sectors are liable to production hold-ups which cannot be allowed to interrupt the operation of the remaining sectors. For example, shortage of rail cars for loading the coal should not halt operation of the preparation plant. Similarly, winding installation standstill should not interrupt the work of the preparation plant. Hence the coal preparation plant should be equipped with suitable hoppers for raw and dressed coal. These hoppers are the element equalizing the production capacities of production shafts, coal preparation plant, coal loading facilities, etc.

Similarly, throughput capacities of the main gotten transport and winding facilities must be coordinated and inequalities compensated for. Surge bunkers should be located at the shaft top, as always practised in the newly constructed and reconstructed mines.

The old system using mine cars at the various levels as surge bunkers is now completely outdated. It is ineffective for modern high production winning, holds up car circulation and is quite unsuitable for main transport by belt conveyor.

Extraction districts must be protected against the effects of stoppages in the main haulage system, particularly when there is high production from longwalls and districts. Even a short break in the haulage system results in big production losses which are virtually impossible to recoup in normal working hours. District or panel surge hoppers ensure suitable protection.

Stowing, transport of materials to the faces and of rock from the first workings are treated as parts of the series system of production sectors. Mine ventilation and mine drainage are also basic elements of the production process, independent of the others.

To establish the complex flow diagram of the mine production, all basic sectors and auxiliary sectors such as power system, water-effluent system, workshop and storage facilities both at the surface and underground, lamp-room, baths, cloakrooms, etc. must be taken into account. The following conditions must be fulfilled:

- adequate production capacity of all production sectors
- safe operation and safe working conditions for personnel
- conformity of design with all the relevant rules and regulations
- reliable operation, minimization of break-downs. Selection of suitable roof support, simple ventilation layouts, heavy duty machines and equipment, wear resistant and reliable, etc.

- minimum labour demand, maximum concentration of production
- maximum exploitation of the deposit
- flexible design allowing for possible adaptation of individual sectors or the whole system to meet any forced changes of production capacity, within certain limits
- minimum investment expenditure and production costs.

### 3.6 Development of the Mine Surface

#### 3.6.1 Model of the Mine Surface Layout

This covers the layout of main and auxiliary facilities sited at the main shaft top and auxiliary shaft tops and their interconnections.

The main shaft station includes facilities and installations linked directly with production, i.e. the headframe, winding installations, buildings for shaft top facilities and winding gear, facilities utilized for transport of the gotten from the shaft to the preparation plant, coal preparation and dispatch facilities, and stowing and ventilation equipment. A number of other facilities are only indirectly linked with the production process, the most important being power supply and distribution equipment, workshops and stores, water-effluent facilities, internal transport system, etc. All these are classified as industrial facilities.

Within the main mine surface area are also non-industrial facilities such as baths, cloakrooms, first-aid stations, administrative buildings.

At the auxiliary (peripheral) shafts tops are sited facilities and installations linked directly with the function of the particular shaft.

Development of the mine surface may be classified as a *dispersed type* or *block type*. The dispersed type (Fig. 3.13) contains a large number of facilities located over a relatively large area. This method was used in Poland for the first mines which were constructed after World War II and is still preferred in some countries. The block method in which individual facilities are grouped together in functional blocks may be designed in a belt or zone form.

The block type requires a smaller site and the total cubic capacity of buildings constructed is reduced while at the same time a more functional technological layout is achieved, particularly for transport. Modern, industrialized construction methods can be used. A recent tendency towards maximum use of block layouts has led to the development of the monoblock design.

In the belt system the individual functional blocks are situated in three to six rows at the mine surface parallel to the longitudinal axis of the mine rail station (Fig. 3.14).

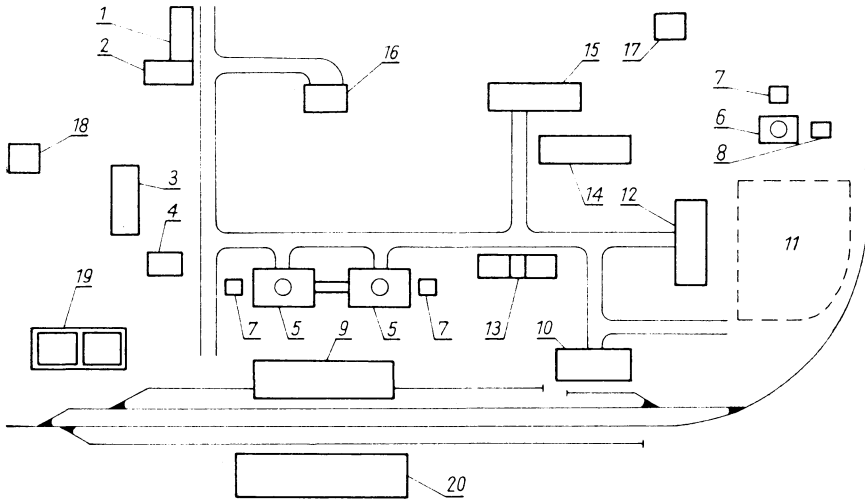

Fig. 3.13 Dispersed development of the mine surface sector; 1—administration; 2—assembly hall; 3—baths; 4—lamp room; 5—production shaft; 6—ventilation and materials handling shaft; 7—winding machines; 8—fan; 9—preparation plant; 10—stores; 11—storage yard; 12—workshops; 13—electric workshop, vulcanization shop, quality control station; 14—electric plant, H.T. switchboard; 15—boiler house; 16—coal individual sale; 17—rescue station; 18—fire service; 19—water/slurry settling tanks; 20—coal tips.

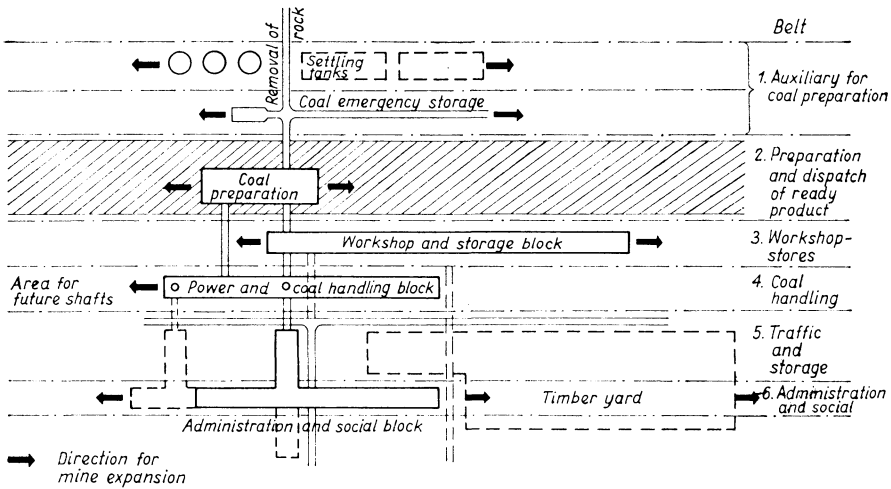

Fig. 3.14 Belt development of the mine surface sector.

In the zone system specific facilities are grouped into functional zones (Fig. 3.15). In both the belt and zone systems development of the surface facilities in stages is envisaged, allowing for possible future extension within the block system.

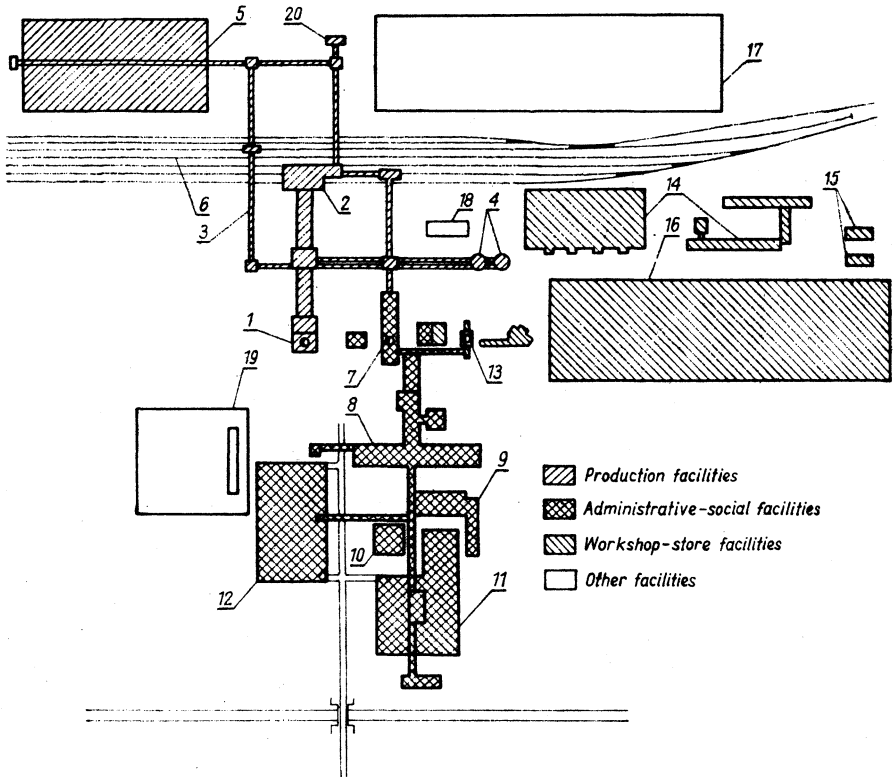

Fig. 3.15 Zone development of the mine surface sector; 1—production shaft; 2—coal preparation plant; 3—transport bridges; 4—raw coal bunkers; 5—coal tips; 6—mine railway station; 7—manriding and service shaft; 8—work safety and health facilities; 9—assembly hall; 10—snack bar; 11—bus station; 12—car park; 13—ventilation and materials handling shaft; 14—store-workshops facilities; 15—stores for special materials (oil, fuel, grease, techn. gases); 16—storage area; 17—water system facilities; 18—heating systems boiler room; 19—main switchboard 220/6 kV; 20—coal individual sale.

The monoblock method locates all the basic production and auxiliary facilities in one block but there are separate shafts (Fig. 3.16). This method is seldom used.



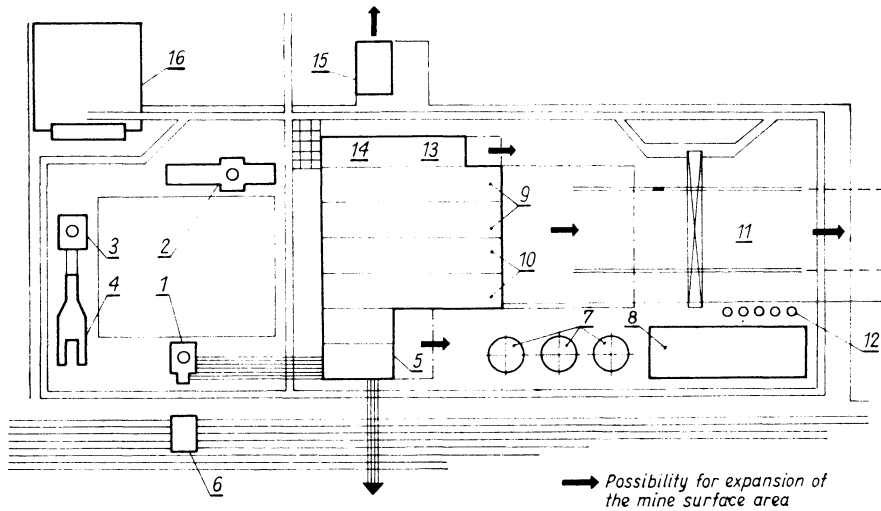

Fig. 3.16 Monoblock development of mine surface sector; 1,2,3—shafts: production manriding and materials handling, ventilation; 4—fans; 5—coal preparation plant; 6—ready product loading station; 7—water system facilities; 8—coal storage; 9—workshops; 10—stores; 11—storage yard; 12—bunkers for loose materials, underground fuel tanks; 13—baths, first aid, rescue, fire fighting stations; 14—assembly hall, supervisory staff, lamp room; 15—administration-management centre, garages; 16—main switchboard 110/6 kV.

The plan showing the layout of all buildings, machinery, components of the mine rail station, road network, internal transport lines and the cable and pipe lines (underground and above ground) is called the *general plan* of the mine surface. This plan forms part of the complex mine construction design and it is prepared in two stages: conceptual and preliminary.

### 3.6.2 Principles for Design of the Main Mine Surface Area

The starting point for design of the main mine surface area is the siting of the mining plant, preliminary selection of the region or locality being followed by the final decision on the exact location. In general, the siting of the mining plant is dictated by the position of the deposit in the mine concession area. The ultimate location of both the main and auxiliary surface areas depends on:

- deposit mining and geological conditions
- ownership of the land
- ground and surface conditions
- existing infrastructure.

Before the detailed development plan for the main mine surface is prepared

it is necessary to:

- fix the siting and duties of the main shafts in relation to the model of the mine underground section
- decide the main streams of gotten, materials, men, water, rock, electric power, heat, compressed air, etc.
- settle the general layout of the surface facilities taking into account configuration of the ground
- fix the size of particular facilities and installations, depending on technical analysis or technical indices
- site the individual facilities and installations in relation to the assumed main production streams.

For this development plan the following principles must be observed:

- mutual siting of buildings, facilities and installations should be adapted to the requirements of the technological processes
- the streams of coal, rock, materials, personnel, etc. should follow the routes established, the shafts being the node points
- distances between buildings should be big enough to comply with fire fighting regulations
- the formation of barren rock dumps and spoil tips in the shaft top area should be avoided
- protection zones and green belts acting as barriers against the harmful effects of dust and noise should be established
- all regulations concerning protection of the natural environment must be rigorously observed.

Special attention should be paid to the zonal arrangement of the surface layout, so that facilities and installations emitting smoke, coal dust, etc. are separated from administrative and social facilities.

### **3.7 Mine Infrastructure**

The complex of basic external installations and buildings necessary for proper operation of the mine forms the mine infrastructure.

The infrastructure has a considerable influence on the siting of the main mine surface. Maximum use should be made of the existing infrastructure facilities and installations in the region where the mine is to be constructed, in particular the possibility of linking the mine with the existing rail and road networks, drawing sufficient supplies of drinking and industrial water and of electric power.

It is convenient to site the main plant reasonably close to towns or settlements to facilitate recruiting local manpower, though special housing for

mine personnel must also be envisaged. On the other hand, the adverse effects of the mine on the environment must also be considered (noise, dust emission, spoil tips, etc.).

Linking up with and making use of the existing infrastructure is usually easier when the mine is constructed in a region where mining development has already taken place. However, if the mine construction involves the development of a new mining region, much of the infrastructure will have to be created.

Access roads to the building site, electric power network and installations as well as basic telecommunication facilities have to be present prior to mine construction.

The next, and vital element of the infrastructure is the housing system. To solve this problem a detailed program must be prepared, taking into account the siting of individual mines, the mine manpower requirements, minimization of the time lost in travelling to and from work, and the expenditure of energy for this transport. In this program, the use of agricultural land for industrial purposes must be kept to a minimum, suitable environmental conditions in the residential areas must be ensured, and, as far as possible, recreational facilities should be provided.

The next infrastructure task is to create an adequate communications network for the needs of the region being developed, and to link it with the national system. The construction of new roads and the modernization of the existing road system, and the laying of railway lines or trunk-lines is often necessary.

The construction of new mines, together with the necessary housing and service facilities, usually requires the construction or modernization of the telecommunication system. In the world of today, the problems of environmental protection have become more and more acute. When considering the principles of mine design and the related infrastructure, especially in the case of newly constructed mines, the protection of the natural environment must be treated as a matter of primary importance.

The problem here is not only preservation of clean air and protection of the surroundings against noise, vibration, and accumulation of mine waste, but also protection of the soil and ground-water against the adverse effects of mining operations and prevention of pollution of surface water by salt underground waters.

Steps must be taken to protect the environment but if waste lands have already been created due to industrial activity, a reclamation program must be planned applying appropriate scientific, technical and organizational measures to restore the land to agricultural or forestry use.

### 3.8 Optimization of the Design Systems

As already said, the individual elements of the production in the mine, i.e. the subsystems of the system, are mutually interdependent. Hence correct choice and coordination of all these elements has a major influence on the economy of the system. The operation and coordination of the elements of production in a hard-coal mine is closely dependent on the natural conditions of the deposit which vary both in time and space. This leads to considerable difficulties in optimization of the system, i.e. the mine.

To establish optimum size and structure of a system it is necessary to make a complex analysis of the whole system. Advances in mathematical optimization methods and the introduction of computer techniques for engineering calculations make optimization feasible, although complicated. Consequently individual subsystems are analysed and partial optima found but their sum does not necessarily represent the optimum solution of the whole system due to the feedback existing between subsystems.

When planning the reconstruction of a mine, the designer has to select the particular subsystem which needs updating. This component must be analysed in detail outside the context of the other components. Naturally, the basic and unchangeable links between the subsystem and the whole system and its environment must be taken into account.

Modern technical design may not (or at least should not) be based on the personal predisposition of the designer or on his creative abilities. When seeking optimum solutions the designer has at his disposal the heuristic method. This does not produce an exact solution to the problem but it is useful in the first stage when design concepts are sought. The heuristic method generalizes experiences and methods of thought in the solving of problems, using logical schemes of procedure in the creative process, known as heuristic algorithms. An illustration of a heuristic algorithm is shown in Fig. 3.17. It eliminates the “blind” search or the laborious analysis of all the variants. Although this simplifies and intensifies the creative processes it does not eliminate the challenge to the creative talent of the designer.

A mathematical model of the system is constructed to help in the choice of the best size and structure, and optimum operational parameters of the system. Simplifications are often made, as it is difficult to model some factors, e.g. the influence of the human factor on the course of production. That often leads to a “model versus reality” situation.

The larger the number of “abstractions”, i.e. simplifications, the simpler is the mathematical model of the system. The more closely the model represents reality, that is, the greater the number of interaction coefficients it con-

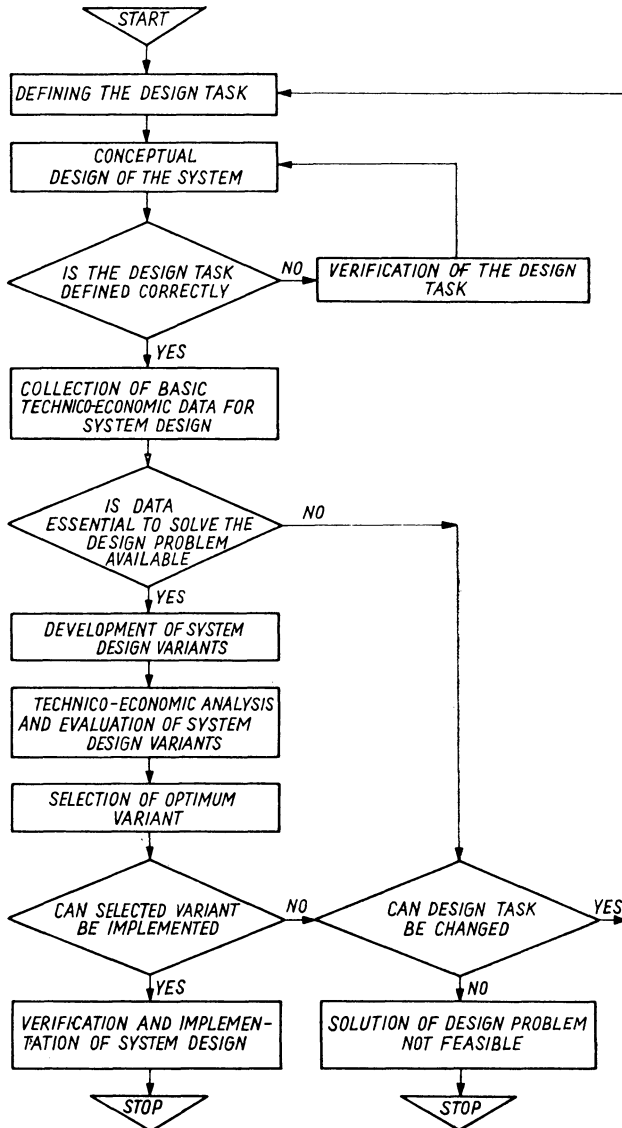

Fig. 3.17 Heuristic algorithm in the system design process.

tains, the more complicated it becomes. Computers enable us to construct models of increasingly small degree of abstraction, and hence more closely simulating reality.

The next step is preparation of the mathematical model for computer

calculations, i.e. development of a logical-mathematical algorithm in a form suitable for programming. This algorithm is a precise prescription comprising:

- description
- mathematical relations
- logical diagram including formulae and verbal instructions for performing analyses in a specific order, serving to solve particular classes of problems.

Development of the algorithm for the mathematical model of the system, its programming and performing the analyses on the computer permits a considerable reduction in the time required for these analyses and, more importantly, they may be performed for any number of variants in a very short time. In this way optimum parameters governing both the structure and size of the designed system may be obtained.

The mine design process comprises three basic stages as described in Chapter 5, i.e.

- the conceptual stage
- the preliminary stage
- the final stage.

Optimization is imposed in each stage of the design, but the number of problems to be optimized varies. For this reason different degrees of accuracy of the system model are required in the different stages. The best results can be achieved by using the most accurate model of the investment project as a whole. By incorporating further knowledge of the technical and economic relations during the investment process for a new mine and in the winning of the deposit, further improvements can be made.

## **Chapter 4**

### **Design of Mine Reconstruction**

#### **4.1 Principles and Purpose**

When the construction of a new mine is considered designs are based on the most up-to-date technical developments available and generally the most modern technical, technological and organizational methods, machines and equipment are introduced. However, science and engineering are constantly advancing while the mine, once constructed, must operate within the framework established at the time of its design and construction. The mine is thus inevitably subject to natural ageing. Worn-out machinery and equipment, i.e. elements of the fixed assets with a limited life, have to be gradually replaced. However, the mine model or the main sectors of the production process are not easy to change. Consequently there is an ever widening gap between the technical efficiency of an existing mine and that of plants designed and constructed later. Thus a mine which at the time of commissioning can claim to be modern, becomes obsolete and has to be modernized in order to increase productivity and reduce labour intensity and production costs.

Such an investment should ensure:

- an increase in the mine production capacity (if development conditions make this feasible) or maintaining the existing level
- an improvement in technical and economic production indices
- modernization of mine production potential
- improvement in safety and health conditions
- introduction of modern, effective coal-getting technologies making use of up-to-date mining techniques.

To describe capital investment undertaken in an operating mine various terms such as modernization, reconstruction or extension are in use. These terms are not always adequate for the investment in question, hence it may be advisable to define them more precisely.

Investment work carried out in an operating mine may be broadly divided into *conservation* and *development projects*.

Conservation projects are designed to secure a simple reproduction of the mine production capacity, i.e. to maintain a stable level of production as particular seams or parts of the deposit are worked out and as production is taken to a greater depth. These are reproduction investment projects, e.g. modernization and replacement of individual machines and equipment as or before their estimated period of service runs out.

The development investment goes further and aims to increase both mine production capacity and production. This type of investment is called *redevelopment* and its scope may be moderate or large. The term *moderate* is generally used for a daily production increase of 10–50% as compared with the previous period. If the planned production increase is greater than 50%, the investment project is classed as large. If this increase does not exceed 10%, such projects are classed as conservation investment (i.e. not classed as development investment). It may be stressed that mine redevelopment is an advantageous form of investment, because the capital required to give the increase in production is much smaller than for the construction of a new mine while the implementation time is much shorter.

In many mining countries the term “mine reconstruction” has come to be used though the meaning here is quite different from that of reconstruction in other fields, such as architecture, civil engineering or the arts. Mine reconstruction implies an investment undertaken in an operating mine which goes beyond simple technological reproduction (production capacity). This means that mine reconstruction is an investment of the development type, reconstructing with or without an increase of the production capacity.

The final result of mine reconstruction investment without an increase in production capacity is simply an improvement in basic economic indices such as productivity, certain costs components, prime costs, etc.

The final result of mine reconstruction investment with an increase in production capacity may be accompanied by simultaneous improvement in basic economic indices. This may be seen as mine development.

Mine reconstruction is an investment undertaking carried out in an operating mine which by changing the structure of the mine, its technological elements or the structure of the fixed assets brings about a change (improvement) in at least some of the basic technical and economic indices.



## 4.2 Initial Conditions and Criteria for Mine Reconstruction

As already mentioned, the creation of new production potential in operating mines is a very effective form of investment due to the smaller capital demand and shorter construction time required. For this reason reconstruction of mines represents a preferred investment.

When considering mine reconstruction, both the scope and the most advantageous moment for commencement has to be decided. Reconstruction starting time depends mainly on the availability of sufficient industrial reserves at the given time, so that the capital investment can be justified and the profitability of investment guaranteed. The level of prime costs or accumulation before reconstruction must be compared with the predicted level after the planned reconstruction. It is also necessary to compare these indices with corresponding figures for other operating or planned mines in similar mining and geological conditions.

The factors influencing the decision on reconstruction starting time are closely interconnected with each other and also with the problem of optimum scope of reconstruction.

All the theoretical and design studies carried out up to now on the material and financial scope of mine reconstruction take as their starting point a predetermined moment for commencement of reconstruction, and may be divided into three main groups according to the optimization method applied, i.e.:

- analytical
- normative
- variant.

The variant method for optimization of reconstruction involves evaluation of a number of technically feasible variants for mine reconstruction prepared by the designer (or design team), who has to analyse existing conditions in the given mine and its development potential. An assessment is made of the economic effectiveness of these variants, followed by a choice of the most advantageous one for implementation. Five characteristic stages may be distinguished:

- I. Analysis and inventory of the current state of the mine.
- II. Analysis of the technical options for mine development and justification of the mine reconstruction.
- III. Elaboration of conceptual designs for reconstruction variants.
- IV. Technical and economic evaluation of variants developed and selection of the optimum variant.
- V. Preparation of designs for the further stages of the investment project.

#### 4.2.1 *Analysis and Inventory of the Current State of the Mine*

Determining the actual state of the mine is the starting point for consideration of the advantages and feasibility of mine reconstruction. Assessment of this state should be based on:

1. balance of existing reserves of useful mineral
2. inventory of fixed assets
3. balance of manpower
4. analysis of technico-economic indices currently achieved.

*Balance of existing reserves of useful mineral.* This balance is prepared for the year preceding the year of planned reconstruction and should include industrial and mineable reserves, indicating particular sectors of the concession area, extraction levels and seams and also the degree of proving, coal types, seam ash content, calorific value and seam thickness. This data forms the basis for the selection of the most advantageous extraction systems. Additionally a profile log of reserves must be prepared indicating the position of existing seams, making it possible to analyse schemes for vertical development of the deposit and to introduce any necessary corrections.

*Inventory of fixed assets.* This involves evaluation of the actual state of mine fixed assets from both the technical and economic aspects (in total mine assets current assets represent only a minor proportion and may be neglected in the overall analysis). The analysis of mine fixed assets should be based on this inventory and an assessment of the technical state of these assets and their net value. Next an objective assessment must be made of the technical/economic value of the individual items of the fixed assets deciding which should be written off or sold due to low output, efficiency and value. In view of the necessary synchronization of the mine technological process certain other items must be scheduled to be written off or sold although they may still represent an appreciable technical and economic value. Decisions must also be made on what other technical and organizational solutions should be introduced to replace the items withdrawn in order to ensure the planned production capacity of the reconstructed mine. The effect of these replacements on employment in the individual production sectors must also be analysed.

As the planned production capacity of the mine is the resultant of the production capacities of the individual sectors, the quantitative inventory and the characteristics of the technical state of fixed assets in the individual sectors are prepared. The following sectors of the mine production may be listed:

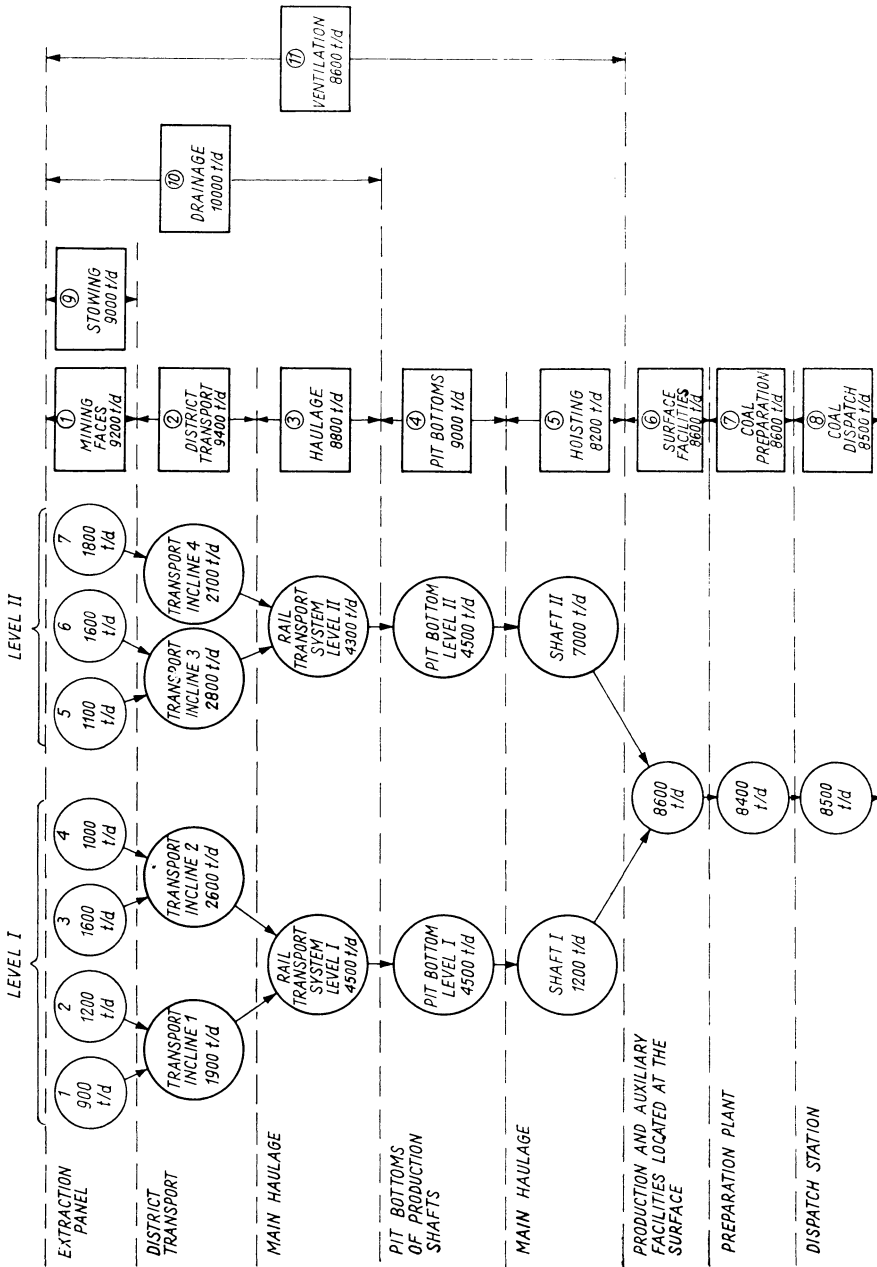

Fig. 4.1 Diagram of connections between mine production sectors including throughput capacities.

- mining faces
- district transport system
- main haulage system
- shaft bottoms
- main winding system
- production and auxiliary facilities located at the surface
- coal preparation plant
- mine railway yard
- stowing system
- drainage system
- ventilation.

The production capacity of each of these sectors must be determined and the ultimate production capacity of the whole mine is then calculated. For this purpose a diagram showing the interrelations of the various sectors is prepared and their outputs are indicated. Figure 4.1 gives an example of such a scheme, from which the actual production capacity of the mine may be found. This is determined by setting out the data for all the sectors and seeking the sector with the lowest production capacity (Fig. 4.2). In the given example the mine production capacity is 8 200 tonnes per day. This figure is limited by the capacity of vertical transport (winding capacity per day) and of the coal preparation plant. These two sectors represent the “bottle-neck” in the

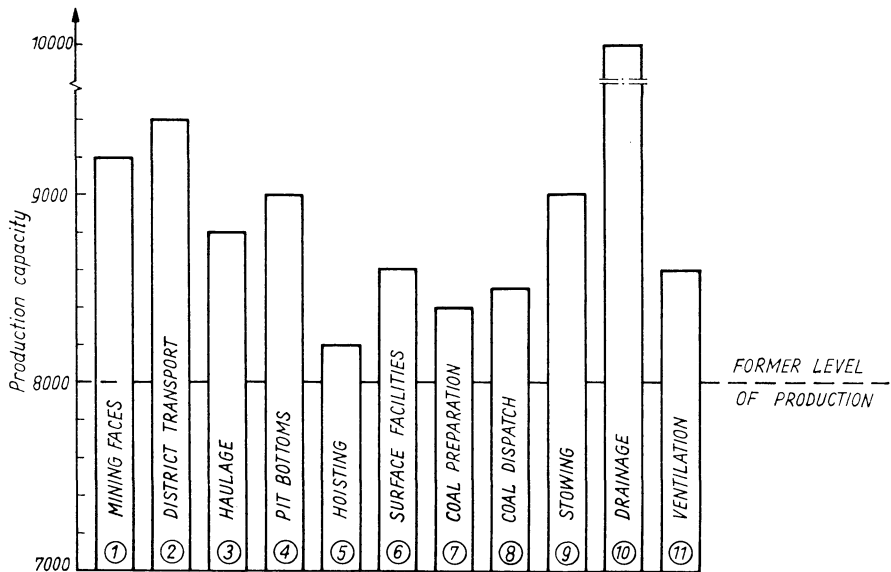

Fig. 4.2 Comparison of throughput capacities of mine production sectors (see also Fig. 4.1).

mine. As the mine produces 8 000 tonnes per day it utilizes about 98% of its capacity.

*Balance of manpower.* A quantitative and qualitative balance is made to evaluate the scope of changes in manpower due to reconstruction. Analysis of the manpower balance may lead to the postulation of increased production concentration and higher technical level in some or all of the production sectors.

*Analysis of technico-economic indices.* This is essential to compare technical and economic indices achieved before reconstruction with those envisaged after, so that the economic effectiveness of the change can be evaluated.

The set of technico-economic indices should include, most importantly, the following:

- mine production capacity
- mine concession area
- number of operating levels
- service life of each level and of the mine
- productivity at the face, underground and for the whole mine
- production costs
- selling price
- value of depreciation.

Auxiliary indices such as costs breakdown, productivity in different types of extraction faces, etc., should also be given.

#### 4.2.2 *Analysis of Technical Development Options and Justification of Reconstruction*

The analysis is performed for the same elements of the existing production process which were previously inventoried. Hence it is carried out for the mineral reserves, fixed assets and manpower, taking into account all existing interconnections. Two aspects are considered, development options and resources utilization and also the advantages and necessity of changing the structure of the production assets and manpower in the mine due to the reconstruction.

The first aspect—development options and utilization of mineral resources — is the key problem when considering the soundness of a reconstruction project. Two cases may be discerned:

- where conditions exist for increasing mine mineral resources
- where existing resources remain the production base.

Neither of these cases governs the decision on reconstruction or type of reconstruction. It may be sound to opt for a reconstruction in both cases,

i.e. with an increase in production capacity or maintaining the existing level. In every case the decision depends on a number of factors, ultimately however on the quantity of resources and on the service life of the reconstructed mine considered as optimum.

In general, a change in the size of reserves or in the extraction method requires a change of the mine model and often of the mine structure since the spatial layout of first workings should secure the rational development of the deposit. Hence a change in reserves or simply in the conception of their exploitation calls for a suitable layout of development workings.

Changes in reserves and in exploitation concept require a change of the mine model in the following cases:

- merger of two or more operating mines
- incorporation of reserves not previously included in the existing mine development scheme
- incorporation of a part of the reserves of a neighbouring operating mine due to readjustment of boundaries
- increase in quantity of industrial reserves and change in their quality as a result of better proving of lower lying reserves, reserves either not included in the previous balance of reserves, or due to changes in balance criteria.

When reconstruction is scheduled without a change in the level of reserves the following may take place:

- division of the concession area and of mine reserves into two or more independent production units or into elementary areas belonging to a mine of collective type
- division of the productive Carboniferous into two separate parts at different depths and establishing within the same mining area a so-called “zonal mine” comprising two independent production units operating in different depth zones.

Sometimes reconstruction is scheduled with no increase in reserves of the operating mine but with a change of mine model and seams development method. This happens when reserves are sufficiently large but the existing mine model and development method have proved unsatisfactory or when other factors (e.g. natural hazards) dictate such changes. Again, an analysis is based on a detailed overall review of the state of fixed assets and the mutual links between the individual sectors of the production (Fig. 4.1). This includes all feasible changes in the fixed assets which could give an increase of production capacity, and improvement in mine economic performance through increased productivity and replacement of out-of-date equipment. The following must be fixed:

- upper limits of production capacity for the particular technological sectors

- practical options for modernization of individual technological processes and modernization of machinery
- restructuring of the manpower, since reconstruction may require qualitative and quantitative changes
- schemes for selling the additional coal produced as a result of reconstruction.

When these points are fixed, a number of feasible reconstruction alternatives may be suggested, followed by conceptual designs.

#### *4.2.3 Developing Conceptual Designs for Reconstruction Variants*

Having determined the feasible reconstruction variants, the conceptual designs are prepared. These should contain a summary of indices and techno-economic parameters specifying the reconstruction itself and the mine after reconstruction as well as drawings and calculations. For each variant the following data must be given:

- investment expenditure required for reconstruction
  - estimated time of duration of reconstruction
  - mine production after reconstruction
  - service life of extraction levels and of the mine
  - face productivity, underground and overall
  - prime costs of production
  - coal quality (type, calorific value, ash content, etc.)
  - selling price
  - structure of fixed assets after reconstruction,
- also any other additional data serving to illustrate and evaluate the reconstruction variants.

A comparison of technical indices before and after the reconstruction forms the basis for technical evaluation of the changes. A summary of economic indices allows an economic assessment of the reconstruction to be made.

Technical and economic evaluation, and selection of the optimum variant takes place in the IV stage of the variant method of reconstruction optimization, which is described in Section 4.4.

#### *4.2.4 Further Stages of Design Documentation*

In stage V of the variant method the selected alternative is developed to a stage enabling practical implementation of the project. The technical and economic principles for the planned reconstruction are worked out and also the necessary technical plans covering all the investment work envisaged. After approval,

the technical designs are prepared and the financing of the investment is arranged. Care must be taken to organize the investment operations so as to avoid as far as possible any interference with normal work in the mine.

All these procedures are similar to those described in Sections 5.2.2 and 5.2.3.

### 4.3 Modernization of the Technological Processes

When the mine reconstruction is to be based on the existing reserves it may be necessary to change the technical level of individual production sectors, to change the model of mine underground and in some cases even to change the size of the mine.

In the first case, i.e. change of the technical level of production sectors, a qualitative analysis of these sectors is made according to the division in Section 4.2.1. The most favourable solutions are selected, specifying the principal parameters determining the size and model of the reconstructed mine and its production sectors, that is:

- mine production capacity
- production life
- depth of extraction levels
- industrial reserves in extraction levels
- number of levels mined simultaneously
- underground and overall mine productivity
- layout of seams development workings.

The characteristic parameters describing the individual sectors of the production process are:

#### *mining front*

- number of simultaneously operating extraction panels and production districts
- mean production concentration from one extraction panel
- number of simultaneously operating faces in the panel
- average advance of the mining front

#### *district and main haulage systems*

- number of loading stations
- number of mine cars per extraction level
- number of locomotives per extraction level
- number of mine cars and locomotives per auxiliary level
- total length of belt conveyors in the main haulage system



*shaft bottoms*

- cubic capacity
- capacity of coal bunkers
- capacity of handling installations

*winding system*

- number of production shafts (also materials and ventilation shafts)
- number of skips in the shafts
- total hoisting capacity of skips
- total hourly throughput capacity of winding installations
- total daily throughput of winding installations
- transport capacity of hydraulic transport system and any other vertical transport arrangements

*surface facilities*

- area occupied by industrial and other facilities
- cubic capacity of buildings

*coal preparation plant*

- scope of coal preparation
- number of types of prepared coal products
- plant daily throughput

*mine railway yard*

- total length of tracks
- daily capacity of handling installations

*stowing*

- daily capacity of hydraulic stowing installations
- daily capacity of dry stowing installations

*drainage*

- total inflow of underground water
- total length of water galleries
- capacity of main drainage pumps

*ventilation*

- mine equivalent orifice
- ventilation capacity of downcast shafts
- quantity of air delivered to the mine

- ventilation capacity of upcast shafts
- quantity of air leaving the mine through the ventilation shafts.

As already stated, mine reconstruction without a change in the quantity of reserves may, in some cases, require modification of the model of the mine underground sector, either in the form of restructured development workings or a change in the number of simultaneously operating extraction levels.

The current trend is to limit the number of simultaneously extracted levels. Hence it may be necessary to drive additional development headings, inclined or vertical (crosscuts, inclined drifts, interlevel small shafts, etc.), in order to reduce the number of extraction levels. This also involves modification of the layout of development headings.

If conditions permit an increase in coal reserves, then reconstruction is achieved by changing the technical level of individual production sectors, modifying the layout of development headings to agree with the planned size and distribution of mine production, and in the case of mine merger by changing existing mine models. When an increase in reserves is envisaged, reconstruction normally results in an increase of the mine production capacity.

When a merger is planned for mines with extraction levels at different depths it is usually necessary to change the model of the mine underground sector and to modify the layout of development headings. Frequently it is also necessary to change the model of the mine surface, i.e. modernization of certain production facilities and in some cases even the construction of a new main mine plant.

A change in the technical standard of individual production sectors, i.e. their modernization, which governs the achieving of reliable operation, safety, and above all satisfactory production and economic effects from the reconstructed mine is called for. General principles and scope of modernization of individual sectors of the production process are discussed next.

*The mining front.* Increasing the range of application and raising the technical level of the coal getting and loading machines and the application of new getting techniques and technologies is involved. The use of heavy duty coal getting and loading machines and face conveyors allows individual roof support to be replaced by powered support leading to complex mechanization of longwalls. Coal extraction then advances more rapidly, production and productivity increase, and the length of the operating extraction front can be reduced. Simultaneously, the main haulage conveyors and district or panel loading stations handling equipment must be modernized. This point will be dealt with in later chapters.

The more convenient extraction panels are often already mined out and

further concentration of production is impossible. It may be necessary to work thin seams and seams located in the safety pillars. In this case modernization depends on selection of suitable extraction methods and technical measures to secure optimum production and economic effects.

*District and main haulage systems.* Modernization of this sector has relied mainly on the introduction of heavy duty belt conveyors with strengthened support structure and lengths of up to 1000 m, suspended conveyors and slow-burning belts, and suspended railways for materials transport. Modernization of the main haulage system involved the introduction of high capacity mine cars, underground locomotives of higher powers, wider gauge tracks and heavier rails as well as mechanization of district or panel loading stations.

Further trends include the introduction of conveyors with wider belts, increased speed of travel and of higher capacity, full automation of the belt conveyor system, adaptation of belt conveyors for manriding, standard application of roof suspended railways and a reduced number of conveyor flights. Surge bunkers located at the district loading points ensure the continuity of work at the coal face. The capacity of these bunkers and handling capacity of the stations must correspond to the planned concentration of production.

New trends in modernization of the main haulage system include the application of large self-discharging cars, full automation of the belt conveyor system and control of the main haulage system from dispatch rooms located at the respective levels.

*Shaft bottoms.* Adaptation to receive and dispatch the quantity of gotten, rock, materials and personnel as specified in the mine reconstruction plans is required. This usually involves restructuring of car circuits and their adaptation for self-discharging cars, the construction of surge bunkers and unloading stations and automation of skip-loading measuring vessels, feeders, etc. If the main haulage system is to be converted to a belt conveyor system, then the shaft bottoms must be adapted accordingly. Together with modernization of shaft bottoms it is also necessary to modernize their technical equipment and that of all adjacent rooms.

*Main winding system.* Modernization here increases the production capacity of the shafts. This is achieved by:

- scheduling shafts for specific transport duties
- improvement in control systems and increase of their drive powers
- increasing effective capacity of skips/cages
- raising winding speed

- improving load handling facilities
- using modern skip guiding devices.

In high-output mines it is often necessary to sink an additional (auxiliary) shaft and to deepen the existing upcast and downcast shafts to improve ventilation and climatic conditions at greater depths.

*Mine surface facilities.* It may be necessary to modernize and extend the whole complex of installations, machines and other facilities located at the surface, e.g. facilities associated with mine operation, coal preparation and dispatch, and services for personnel.

The principal mine surface facilities are concentrated near the main shafts in the vicinity of the so-called main plant. In mines scheduled for reconstruction, the layout of the surface buildings is usually dispersed so that spatial utilization is low. Often there is no functional scheme linking the individual facilities, giving unnecessarily long transport routes between them and making collisions more frequent. As a result mine surface operation is labour intensive and personnel employed unjustifiably large.

For these reasons modernization of the mine surface should have as its object:

- grouping of facilities in functional blocks
- shortening of transport routes and simplification of transport network
- broadening the scope of mechanization and automation of the production processes, introduction of more efficient machinery and equipment
- modernization of social and workshop-stores facilities
- centralization of services for power supply, materials handling, water-effluent economy, dispatch, etc.

*Coal preparation plant.* Modernization of this sector includes:

- simplification of the technological processes and introduction of up-to-date heavy-duty machines and equipment
- reduction in number of coal grades produced
- centralization of the preparation processes in one building
- making the coal preparation plant independent of the operation of production shafts and of coal dispatch (bunkers for raw and prepared coal)
- introduction of closed water circuits
- automation of individual technological sections, of groups of sections and ultimately of the whole preparation plant.

*Mine railway yard.* Modernization of the mine railway yard is principally achieved by:

- extension of sidings and railway yards to cope with the planned increase in production
- increasing traffic capacity by increasing capacity of the tracks
- improving car handling by the introduction of modern locomotives and other equipment
- introduction of modern devices for traffic control
- use of systems and equipment for quick car loading.

*Stowing.* Modernization of stowing includes:

- increasing the number of stowing bunkers and introduction of up-to-date metering and measuring devices
- installing pipes with abrasion resistant linings in the supply system, rubber pipes at the faces and mobile stowing dams operating in a synchronized system with the powered roof support, etc.
- full supply of thick mixture to the stowing pipelines
- continuous stowing of faces
- automation of the stowing process
- adding crushed rock (mine waste) to the hydraulic stowing mixture
- preparation of material for dry stowing underground
- improvement in stowing water economy.

*Drainage.* Modernization of mine drainage is concentrated on:

- adapting gautons, water galleries and tanks, settlers and pump rooms for increased inflow of underground water
- increasing capacity of pumping units and direct delivery of water to the surface, cutting out intermediate tanks at upper levels
- centralization of the equipment and pumping of water to lower located levels to reduce the number of main water drainage rooms
- utilization of mine waters for industrial purposes (in coal preparation plant, for hydraulic stowing, etc.).

In mines with water inflows of varied degree of salinity and where, in order to protect the rivers, it is necessary to control the input of salt underground water, adequate facilities must be provided underground for qualifying the waters according to suitability.

*Ventilation.* In deep mines, extraction levels are gradually being taken to ever greater depths. This fact is reflected in mine reconstruction designs when dealing with ventilation and air conditioning. Reconstruction is often linked with extension of the mine concession area. As regards ventilation, modernization involves adapting the ventilation and air conditioning systems to suit

the new conditions resulting from the mine reconstruction. This is usually achieved by:

- simplifying and updating the ventilation system
- installing new high output and low depression fans grouped in fan stations
- using ventilation stoppings and modern air-intake-shaft gates to eliminate air losses
- limiting the inflow of methane to workings, increasing the efficiency of methane drainage, introducing automatic control of methane concentration in the mine air
- optimization of cross-sections of ventilation roads
- introducing air conditioning.

#### 4.4 Technical and Economic Evaluation of Mine Reconstruction Variants

Technical and economic evaluation of mine reconstruction variants is developed in the penultimate stage (Stage IV) of the variant method for optimization of reconstruction plans. From this evaluation an optimum variant is selected for implementation.

Assuming that each of the considered variants is technically sound (only such variants may be analysed), the final choice rests with economists.

However, economic performance is not always the sole criterion for selection of an optimum variant. In some cases, promoting the extraction of coking coal, industrialization of economically backward regions, etc., may be the deciding factor.

Various methods and criteria for economic evaluation of capital investment projects are available and different countries use different approaches. In Poland, the predicted economic effects are compared with the capital expenditures necessary for investment implementation. Evaluation of economic effectiveness is made by calculating the so-called *indicator (index) of economic effectiveness*  $E$  and then the following questions must be answered:

1. Does the reconstruction variant meet the minimum effectiveness requirement? This is the so-called *absolute evaluation* of economic effectiveness.
2. Which of the analysed variants is the most favourable judged by the criterion set in this method? This is the so-called *relative evaluation* of economic effectiveness. Indicator of economic effectiveness  $E$  may be in quotient form ( $E_i$ ) or differential form ( $E_r$ ). The requirement of investment effectiveness is fulfilled when:
  - the value of the indicator  $E$  is not less than one ( $E_i \geq 1$ ) for the quotient form,

— the value of indicator  $E$  is not negative ( $E_r \geq 0$ ) for the differential form.

The most favourable variant of mine reconstruction is that which gives the maximum value of indicator  $E$ .

In the analysis of investment effectiveness the discount rate should be taken into account, that is, the estimated percentage repayment rate of investment credits advanced. Variants of mine reconstruction may differ in:

- length of time required for investment implementation
- length of production life of the reconstructed mine
- distribution of expenditure and effects in these periods.

Since for different variants there is a different time distribution of both expenditure outlay and of effects achieved, it is necessary to consider the discount rate in order to bring these expenditures and effects to a comparable form.

Relative losses and gains caused by the delay or speed-up in achieving effects and in investment expenditure may be assessed. The indicator of economic effectiveness  $E$  has the following forms:

*quotient form*

$$E_i = \frac{\sum_{t=0}^m (P_t - K_t) (1+r)^{-t} - \sum_{t=1}^u U_t (1+r)^{-t}}{\sum_{t=0}^m (N_t - Z_t) (1+r)^{-t}} \quad (4.1)$$

*differential form*

$$E_r = \sum_{t=0}^m (P_t - K_t - U_t - N_t + Z_t) (1+r)^{-t}, \quad (4.2)$$

where:

- $m$  — calculation period in years
- $P_t$  — value of yearly production
- $K_t$  — cost of yearly production
- $U_t$  — value of gross production surplus predicted for consecutive years of period  $u$  for the non-reconstructed or non-modernized mine
- $u$  — predicted period in years during which gross surplus  $U_t$  will occur
- $N_t$  — investment expenditure, per year
- $Z_t$  — yearly sale value of production property
- $r$  — calculation discount rate, %/100.

Compliance with minimum requirements of effectiveness (for quotient form  $E_i \geq 1$ , for differential form  $E_r \geq 0$ ) ensures repayment of credit advanced out of surplus (value of production less production costs) in the calcula-

tion period. If the indicator of effectiveness  $E$  calculated for a discount rate of 3% is less than 1 or negative, then the evaluation of effectiveness should be supplemented by an analysis of repayment of bank credits.

Principles are also given for fixing the individual values for the calculation of the indicator  $E$  as in formulae (4.1) and (4.2).

*Calculation period  $m$ .* This is the sum of the period of investment implementation  $b$  plus calculated period of production life  $n$ . The first year of investment implementation is taken as the first year of calculation period  $m$  ( $t = 1$ ). The two components of the period  $m$  are determined as follows:

- $b$  is taken as the normative or directive length of time for investment implementation
- $n$  is calculated on the basis of the average rate of depreciation  $Sta$  of the fixed assets resulting from this investment, and on amortization of non-material and legal outlays. The calculation formula is:

$$n = \frac{\ln \frac{Sta + r}{Sta}}{\ln(1 + r)}, \quad (4.3)$$

where  $r$  is the calculation discount rate expressed in %/100.

The calculated period  $n$  should be compared with the maximum period of credit extended for the reconstruction and the shorter of the two accepted. The maximum credit periods for reconstruction are: 10 years for steam coal and 12 years for coking-coal mines.

*Calculation discount rate  $r$ .* The basic parameter used for hard-coal mines in Poland is the calculated value of the indicator  $E$  taking a discount rate of 3%. For other branches of industry indicator  $E$  is calculated at a discount rate of 8%.

*Value of yearly production  $P_t$ .* The value of yearly production in consecutive years during and after the completion of reconstruction is determined as follows:

- net daily production is multiplied by 305 days to give annual production
- annual production is multiplied by the average coal selling price.

*Cost of yearly production  $K_t$ .* This is the total prime cost in consecutive years during and after completion of reconstruction,

- less amortization, rental on basic mining machinery and equipment, interest on bank credits for investment and working assets
- plus tax payments for wages bill.



*Value of gross production surplus  $U_t$ .* This is the difference between the value of production and the running costs envisaged for consecutive years of the period  $u$ . It is gained due to exploitation of the production assets scheduled to be modernized or extended, which would be obtained assuming that no reconstruction or modernization took place. In calculations, only positive values of surplus are taken into account, the negative values are neglected.

*Investment expenditure  $N_t$ .* This is the sum of the nominal investment expenditure  $I_t$  in the consecutive years of reconstruction plus expenditure to form a reserve of working assets  $B$ , i.e.

$$N_t = I_t + B. \quad (4.4)$$

Expenditure to form a reserve of working assets is calculated as follows: determined reserve for the final year of reconstruction should be compared with the initial year and the difference is introduced in proportion to production development. The necessary reserves or working assets calculated in this way should be deducted in the last year of the calculation period.

*Sale value of production assets  $Z_t$ .* This is the sale value of production property withdrawn during the mine reconstruction.

#### **4.5 Examples of Hard-Coal Mines Reconstruction**

After World War II the wide-scale reconstruction of hard-coal mines was common and almost universal, particularly in those mining countries where investment had been slowed down or even stopped due to the war and where the economic, social and energy needs forced the undertaking of mining investment in order to expand coal production and improve technico-economic indices in the mines. At that time the majority of the mines were small-capacity units (mines of 3 000–5 000 tonnes per day were seldom found) using low productive systems and technologies. The reconstruction was accompanied by modernization of systems and technologies. Longwall mining became more widely applied. New improved designs of shearer-loaders, coal ploughs, powered roof support, face conveyors as well as new horizontal and vertical transport equipment were introduced.

Substantial advances were achieved in the mechanization of development work and materials handling, and new coal preparation technologies were employed. The result was a notable increase in production; mechanization and electrification indices rose appreciably with a consequent growth in productivity and economic effectiveness.

The British coal mining industry may serve as an example. Following nationalization of the industry in 1947, the governing body, the National Coal Board, scheduled the reconstruction of coal mines as their first priority.

In 1947 coal production in Great Britain was 197 million tonnes, overall productivity 1 091 kg/O.M.S., underground productivity 1 460 kg/O.M.S. while the labour intensity expressed as the number of working days per 1 000 tonnes production was: 350 at the faces, 335 underground outside the faces, 232 on the surface, a total of 917 mandays per 1 000 tonnes of production. During its first four years the NCB dealt with employment and organizational problems both in the mines and throughout the whole coal-mining industry. The real reconstruction was started in 1951, i.e. the creation of a sound mine model ensuring maximum possible concentration in all production sectors. Shafts were deepened where necessary, the number of extraction levels, production headings and loading stations was reduced while the mean capacity of mine cars was increased. The reconstruction program included ventilation, transport facilities, main haulage and winding installations and also coal preparation plants, power installations and surface facilities. The next task undertaken was intensive mechanization of the coal getting, the starting point for developing production districts of high-output capacity of the order of 1 000–1 500 tonnes per day. The result was a growth in production from 197 million tonnes in 1947 to 224 million tonnes in 1953, with prospects of further production growth. Although in the years 1956–1960 coal production dropped from 222 to 202 million tonnes (due to the coal crisis) the actual production capacity of the mines was substantially larger. However, in spite of the drop in production, due to reconstruction and mechanization a systematic increase in underground and overall productivity was achieved as well as a marked decrease in labour requirements, and all this in a comparatively short time.

In 1960, i.e. ten years after starting the actual mine reconstruction program (1951), the overall output had already reached 1 424 kg/O.M.S. (an increase of 30.5% compared to 1947) and the underground output was up to 1 803 kg/O.M.S. (an increase of about 23.5%). Hence a significant reduction in labour for underground work from 685 mandays per 1 000 tonnes in 1947 to 554 mandays per 1 000 tonnes in 1960 was gained. The corresponding figures for surface work were 232 and 148 and for the total mine 917 and 702. In all the reconstructed and modernized mines considerable increase of economic effectiveness was achieved. In certain mines the profit increase exceeded 100%, e.g. at Maltby mine in the Yorkshire coalfield due to reconstruction the profit per tonne of coal rose from 9 shillings and 11 pence (1950) to 19 shillings and 4 pence (1959).

Another example of a post-1945 hard-coal mine reconstruction program

on a broad scale is the mining industry of the Soviet Union. The demand for energy raw materials was enormous and the reconstruction of working mines and the construction of new mines became imperative. The first task was to achieve a rapid increase in the production capacity of existing mines, extension of their service life, increase in technico-economic indices and in economic effectiveness. In the first stage, up to the end of the nineteen fifties, efforts were concentrated on improving the layout schemes for deposit development and seam panelling and on introducing extraction systems which would ensure a two- or even three-fold increase in production concentration (as compared with the initial level) in the extraction districts, at the loading stations and extraction levels. Organization in all mine sectors was improved. Large investment was made (sinking of new shafts and deepening of existing shafts, driving of drifts, cross-cuts), transport facilities, main haulage and winding installations were reconstructed. Single shafts were sunk in parts of the deposit located below operating extraction levels, new galleries were driven or the cross-sections of existing roadways were increased to improve ventilation and to adapt to new transport facilities. Neighbouring small mines were merged into one production unit and, most importantly, technical and organizational innovations ensuring further development in technico-economic indices were introduced. A major contribution in achieving this goal came from the mechanization of coal getting at the faces, introduced on a wide scale in very differentiated geological conditions. Modern powered roof supports, mechanization of road drivage and shaft sinking were used. The number and variety of coal basins in USSR with their specific mining-geological and development conditions makes it impossible to present an overall assessment of the scope and effects of the reconstruction program carried out in the Soviet hard-coal mines but some idea may be given by the data for the Donets Coal Basin. Before reconstruction some 536 hard-coal mines were operating with a yearly production capacity of 151.9 million tonnes, i.e. the mean yearly production from one mine was only 284 thousand tonnes. The underground output per man per month was 24.8 tonnes. The first reconstruction projects envisaged a reduction in the number of mines to 281, an increase in their production capacity to 158.9 million tonnes, that is, doubling the yearly production per mine (from 284 to 565 thousand tonnes), an increase of underground output per man per month to 45,4 tonnes (i.e. 83%) and a decrease of about 35% in costs of production of 1 tonne of coal. These plans were realized and in 1967 new technical and economic targets were set for this coal basin, considerably higher than the previous ones. Experience gained in the reconstruction of operating mines clearly indicated that the production capacity of a mine should be not less than 4000 tonnes

per day. In the Donets Coal Basin reconstructed mines with a target production capacity of 10–12 thousand tonnes per day are by no means unusual at present.

In Poland the need for the reconstruction of mines and the consequent advantages were very early recognized. The enormous tasks confronting the mining industry after 1945 and the continuing pressure to meet the needs of the dynamically expanding national economy, made it imperative to seek the most technically and economically effective forms of investment to increase the production potential of the mines. In view of the very short time available the only solution was to reconstruct and modernize the mines according to up-to-date production systems and technologies. The vital period was up to 1970, during which time the greatest restructuring of the Polish coal-mining industry was accomplished. Obviously mine reconstruction is never ending (Fig. 4.3), as even new mines require redevelopment after 10–15 years of operation. The share of production from reconstructed mines in the total output of the Polish coal-mining industry is somewhat smaller than in the first 25 post-war years due to the large number of new mines commissioned in this period (in 1983, 20 new mines out of a total of 67 mines). Table 4.1

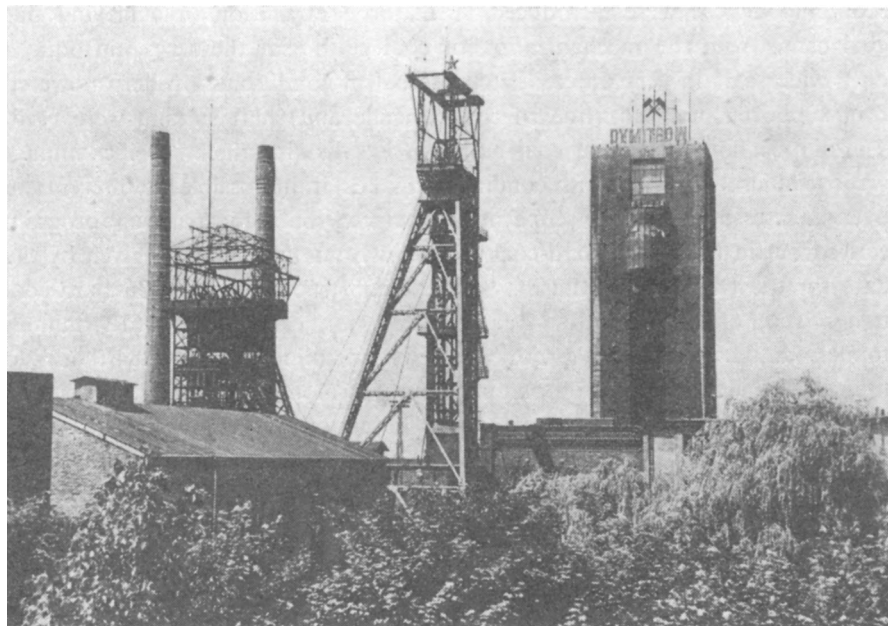

Fig. 4.3 Three generations of headframes in one of the Polish mines: from the end of 19th century, from the 1920–1940 period, from the end of the sixties. Visible example of reconstruction in coal mines.

TABLE 4.1 Development of production concentration in Polish hard-coal mines

Mines of production capacity	Number of mines in years					
	1948	1955	1960	1965	1970	1983
Below 2000	17	15	12	11	3	3
2000 to 4000	41	37	28	22	16	5
4000 to 6000	14	18	27	24	17	10
6000 to 8000	—	7	12	17	25	10
8000 to 10 000	1	2	2	6	14	14
Above 10 000	—	—	—	1	2	25
Total number of mines	73	79	81	81	77	67
Mean production from one mine, t/day	3000	3690	4127	4805	5850	9407
Mean production from one extraction level, t/day	1358	1422	1574	1705	2346	3615

illustrates the number and the size of Polish hard-coal mines, and gives the mean underground production from one mine and from one extraction level. These figures are a measure of the structural changes effected in the industry. Up to 1970, 35 Polish steam-coal mines were reconstructed. Table 4.2 shows the technical and economic indices for these mines before and after reconstruction. Data presented in this table represent the most convincing arguments for a policy of mine reconstruction.

TABLE 4.2 Technico-economic indices of 35 Polish steam-coal mines reconstructed up to 1967

Comparison	Production t/day	Productivity kg OMS	Costs of production zlotys/t	Selling price zlotys/t	Accumulation zlotys/t	Profitability %
Before reconstruction	161 513	1347	248.5	282.6	35.7	12.2
After reconstruction	275 000	1984	238.6	326.0	87.8	36.8
Difference	+113 487	+637	-9.9	+43.4	+52.1	+24.6

## **Chapter 5**

### **Design of New Mines**

#### **5.1 Initial Design Data**

The mining and geological characteristics of the deposit and the overburden is the starting point for any design when developing hard-coal deposits.

The characteristics of the deposit should include the following:

- depth and inclination of individual seams
- type and properties of rocks accompanying the seams
- properties of the coal
- existing and possible hazards
- disturbances in the deposit
- quantity of mineable coal in the deposit and in individual seams.

The characteristics of the overburden should include all the overlying strata, detailing their physico-mechanical and hydrogeological properties. Of particular importance is information on:

- geomechanical properties of the individual layers
- bulk density, angle of inclination and coefficient of compactness of the individual layers
- number, thickness and depth of occurrence of the individual water-bearing layers
- mean water inflow to the mine workings and its chemical composition.

This data is contained in the geological reports on the deposit. The accuracy of the geological documentation and the correctness of the conclusions presented in it directly influence the risk of errors being made by the design team. Careful preparation and presentation of data on the deposit mining-geological conditions has a decisive influence on the results of optimization analyses and on the total complex design for the new mine. An accurate evaluation of coal reserves and determination of their spatial distribution in the deposit is particularly important.

Geological documentation of the deposit contains a statement of recoverable reserves (including division into seams) located within the prospected area. When designing a new mine (or a new level in an operating mine) the size of industrial reserves, i.e. the part of the recoverable reserves scheduled for extraction, is calculated. The remaining reserves are classed as non-industrial, i.e. reserves which for technical or economic reasons are not planned for extraction during the period of mine design or in the nearest future, but may be exploited at a later date.

The industrial reserves less the losses associated with deposit exploitation are called the *workable reserves*. These form the basis for the calculation of production capacity of the whole mine and its individual sectors.

The gross production from the mine during its whole service life is determined by the size of the workable reserves.

In general, the mines do not sell the raw coal (run-of-mine) but process the whole or part of the gotten in their own preparation plants where the barren rock is separated out. The most important quantity is the net coal production, that is gross production reduced by the quantity of waste separated during coal preparation. The differences between the gross and net production are sometimes considerable, even exceeding 40%, depending on the content of barren rock in the gotten. The term *net reserves*, corresponding to net production, is also used. The aggregate net production during the service life of the mine is called the *net workable reserves*. It is obvious that all designs for the whole mine production must be based on gross production.

## 5.2 Stages in Mine Design

The design of a mine is not a single act which produces the complete documentation describing the future mine and exploitation of the deposit. It consists of several stages during which the object of the design becomes defined with increasing accuracy. These stages are:

- conceptual design
- preliminary design
- final design.

The design process starts at the moment when the decision to construct a mine on a specific proved deposit is taken.

The essential foundation for the economic development of every country is an assumed supply of fuel and power. It has been shown that coal is, and will long continue to be, the basic world source of fuel and power. Consequently all efforts made to promote the development of the coal-mining industry have a sound justification. However, the development investment in

this industry is both costly and time consuming. Hence it is essential to maintain a constant program of investigations into the needs and the feasibility and means of creating new production potential in the coal-mining industry. This should include long-term assessment of the demand for coal and identification of areas suitable for mining development. Existing mines should be scrutinized for possible extension or modernization. In different countries mining development is the responsibility of different institutions depending on the local social and economic system. In every case, however, planning is indispensable and must envisage long-term goals in mine construction and production capacity. The programming of mining development could be considered as the first stage of mine design because it establishes the region and the site of future investment and the required size of new production capacity.

The program for mining development forms the basis for the decision to undertake investment activities for which the first step is the design work: conceptual, preliminary and final.

*Investment activity* means the implementation of a specific investment undertaking. An *investment undertaking* is the work planned in order to implement an investment for a defined reason in a scheduled place and time (e.g. construction of a new mine or development of a mining region). The *investment undertaking* comprises the complex scope of factual basic investment work together with jointly undertaken and auxiliary investment projects. *Basic investment* is the part planned directly as production investment, and the principal objective is to achieve a specific production effect (e.g. the construction of a mine). *Joint investment projects* are those undertaken by more than one investor and are planned for more than one user (sewage treatment plant, railway lines, roads, etc.). *Auxiliary investment* is intended to ensure proper operation of the basic investment and includes expenditure for construction of non-production facilities to serve the social welfare needs of the employees and their facilities (e.g. mine training school, residential buildings, baths).

Investment undertakings are divided into *investment tasks*, each task covering a part of the investment undertaking that forms an organic whole. Examples of investment tasks are the construction of coal preparation plant, mine railway yard, administrative-social complex, shaft sinking, construction of a residential settlement, hospital or mine training school.

The unit components forming the investment undertakings and tasks are investment facilities. An *investment facility* is a part of the investment task such as a building or structure, developed and panelled mining area or a mine heading complete with machinery and equipment necessary for its functioning.



In certain countries (e.g. in Poland) all investment facilities are specified in a “unified classification of investment facilities” which lays down nomenclature and practical scope of individual investment facilities, determines unified symbols for the purposes of investment planning, design, implementation and accounting. This classification makes it easier to execute investment design accounting and analysis in compliance with current regulations. It also forms the basis for comparison of investment costs and characteristic indices.

In certain countries (e.g. in Poland) there are rules, instructions or guidelines laid down which govern the principles to be observed in mine investment design. These regulate:

- the scope of technical and economic principles to be decided for investment undertakings of major importance for mining
- the scope of analyses to be undertaken to establish the technical and economic design principles
- the scope of technical designs for individual investment facilities.

### 5.2.1 *Conceptual Design*

Conceptual design is related to a specific investment undertaking. In the case of construction of a new mine it is prepared for a specific mining area or mining region with a proved deposit and known mining-geological conditions of the deposit and overburden. At this stage the overall concept for design of the new mine is prepared in a multivariant form. Each variant contains three fundamental elements, i.e. extent of the mine concession area, the level of production and the mine model.

Coal reserves are directly governed by the size of the mining area. If the size of the mining area and the level of production are not imposed in advance, then variants with different production capacities and different mine models are prepared. They usually differ in the economic profile. When limitations are imposed in advance, that is determined extent of mining area or fixed production capacity, the multivariant approach involves a suitable choice of feasible combinations of the two remaining fundamental elements of the conceptual design. When, however, both size of mining area and production capacity are predetermined, then the individual variants differ in the accepted model of the mine.

In particular cases it is also necessary to take into account other limitations imposed by the investor which may influence the concept of mine construction. Such limitation may refer to the degree of mechanization of mining work (manpower deficit or surplus), scope of coal preparation, etc.

For the further design work the most technically and economically advantageous variant is chosen.

### 5.2.2 Preliminary Design

The conceptual design chosen from the different variants is developed in the form of technical and economic principles for the investment undertaking. These principles are developed to a degree enabling investment implementation to be commenced and when approved they constitute the preliminary investment design.

The scope of the technical and economic principles (preliminary design) varies from country to country depending on the economic system, investment financing institutions and other formal requirements.

They should include:

1. Justification for the need and purpose of the investment.
2. Comparison of indices presented in technical and economic principles and those for the optimum production variant as schemed in the conceptual design.
3. Review of siting problems, including choice of site, ownership of the land, extent of the area essential for investment implementation and of requirements and needs of environmental protection.
4. Technical characteristics of the investment undertaking presented in the form of tables and supplemented by specifications including production program and technology.
5. Technical and economic assessment of the expenditure for undertaking mining operations in view of the surface protection.
6. Specification of necessary machinery and equipment, taking into account necessary import.
7. Valid restrictions.
8. General information on methods of executing mining work, construction-installation work, types of structures and industrialized building methods.
9. Data on auxiliary and joint investment projects necessary to achieve the target production.
10. Summary of total investment costs including an economic analysis.
11. Operative timetable for implementation of the investment undertaking broken down into investment tasks, timetables for individual tasks divided into stages (approved by subcontractors), timetables for financing the investment tasks for particular facilities and agreed delivery schedules for technical equipment.
12. Timetables showing planned progress in reaching design production capacity and final costs of production.
13. Comparison of basic technical and economic indices for the planned mine with those of comparable operating mines, justification of the choice of

technical and organizational methods with particular reference to indices determining the level of costs and profitability, structure of employment and productivity (in case of reconstruction, extension or modernization of an operating mine—comparison of indices before and after carrying out the investment project).

14. Official records of agreements on initial data for costs accounting and also copies of other relevant agreements.
15. Necessary graphical material illustrating development of the site, location of facilities, technological processes, etc.
16. Timetable for delivery of technical designs for the individual investment tasks.

The deposit development plan which specifies the size of the hard-coal reserves and the accompanying minerals scheduled for extraction as well as the scope and method of their extraction should form an integral part of the principles.

When the construction of a new mine is considered the technical characteristics listed in point 4 should include characteristic parameters of the mining area and of the deposit, description of mine boundaries, data on reserves, types of coal and accompanying minerals, development of the deposit, mining hazards, development of output, implementation cycle and cycle for reaching the design production potential, shafts duties, schemes and layouts for underground transport, ventilation problems, air conditioning, methane drainage and dewatering, energy supply, communications, coal preparation, water-sewage economy, workshop and storage facilities, waste economy, problems of work safety and health, recultivation of land and protection of the environment, predictions of surface deformation, rail and road transport system and other problems deriving from the specific nature of the region, infrastructure, etc.

In the case of extension, reconstruction or modernization of a mine the technical characteristics listed in point 4 together with production program and technology should include the same elements as for the construction of a new mine; however, the existing state of the mine must be taken into account in the planning of all investment work and schemes should be worked out to avoid any hitches or collisions in investment implementation due to the normal mine operation.

The summary of costs listed in point 10 should include all costs of all investment tasks and also a breakdown of costs for each individual investment task, and specify them.

The graphical data listed in point 15 should include:

— location plan of the mining area

- general geological and mining characteristics of the deposit
- profile log of industrial reserves
- layouts of winding installations for individual shafts
- diagrams showing development of production capacity and of output from particular levels and from the whole mine
- typical geological cross-sections for the mining area
- general plan for development of the investment site (main minehead and peripheral mineheads) with a list of projected facilities and those scheduled for demolition
- plans of levels currently extracted and scheduled for extraction
- spatial diagram of the transport system
- spatial and canonic diagram of ventilation system
- diagrammatic scheme of the electric power supply system for the mine and its facilities
- layout of main mine drainage system
- layout scheme of hydraulic stowing system and other technological systems (methane drainage, utilization of waste, etc.)
- diagram of water-sewage system and of environment protection facilities
- general plan of mine railway yard
- list of standard and repeatable designs useful in the investment implementation.

In some countries the development of preliminary designs is regulated by guidelines, instructions or regulations. In Poland, these rules are given in “Guidelines for the arrangement and form of technical and economic principles for hard-coal mines”, prepared at the Chief Mining Studies and Design Office in Katowice.

When approved by the appropriate authorities, these principles form the basis for final designs and constitute the formal go-ahead for the investment.

### 5.2.3 Detailed Design

Detailed design involves the preparation of technical designs for the individual investment facilities.

The technical design should include:

- descriptive part giving the basic data determining the investment facility, and in the case of extension or reconstruction projects a description of current state (as shown in the inventory carried out)
- detailed site development plan showing where the projected facility is to be located and a location plan for facilities to be constructed underground
- technical descriptions, results of calculations, diagrams, technical drawings and workshop drawings as required by the subcontractors

- specification of machinery, equipment and materials
- cost estimates and summary of costs for the investment facility
- comparison of costs with estimated expenditure in the technical and economic principles; in the case of discrepancies a detailed justification must be shown
- technical and economic indices and their comparison with the indices given in the technical and economic principles, including detailed justification in the case of differences arising
- provisions stating special regulations applying in a particular facility (e.g. protection against methane and coal-dust explosion, etc.)
- list of individual designs and drawings forming the complete technical design.

Standard and repeatable designs which cut down design time and costs, and investment implementation time and costs should be utilized. This also has the obvious advantage that the standard designs have already been technically and operationally proved in practice. Clearly they need to be adapted for actual conditions and must comply with the approved technical and economic design principles.

The prepared designs are studied and formally accepted by the investor or, after agreement with the investor, by the subcontractor who checks that documentation is complete and complies with technical and economic design principles.

As already mentioned, the design principles give the formal basis for starting investment implementation. This means that certain jobs such as the site development, earth moving work for surface installations, etc., may be commenced without the final documentation. The aim is to shorten construction time for the whole investment thus shortening the non-productive time of freezing of credits already advanced. The technical designs for individual facilities are prepared during the construction. Obviously, care must be taken to ensure that these designs are correct and supplied well in advance to eliminate the possibility of hold-ups due to lack of drawings. The necessary building materials, installations, technical and electrical equipment and machinery are ordered in advance.

The design engineers carry out the author's supervision during the implementation of the planned investment.

### **5.3 Optimum Size of the Mine**

The size of the mine is determined by:

- mining area, km<sup>2</sup>

- workable reserves, million tonnes
- service life of the mine, years
- net daily production from the mine, thousand tonnes per day.

These parameters are closely interconnected as already explained in Section 5.2.

The parameters determining the size of the mine are the most important in the whole mine design. Their values together with the parameters of the mine model, constitute the basis for the overall conception of the mine design, and hence have a decisive influence on the organizational, technical and technological solutions developed for the planned mine. This design scheme should not only allow the mine to be built but should also, and most importantly, ensure maximum economic effectiveness of exploitation of the given deposit that can be achieved within the determined investment expenditure.

At the conceptual stage of design the optimum size of the proposed mine has to be determined. This is done by optimization analysis, based essentially on economic criteria. Mining, geological and technological limitations must also be taken into account, designing for maximum exploitation of the deposit and maximum utilization of available technical facilities.

Many methods are available for estimating optimum parameters determining the size of the mine. They include: statistical, normative variant, analytical and combined analytical-variant methods. The authors of the most important methods are: Zwiagin, Riman, Boryczko, Szewiakow, Benthaus, van Wahl, Ajdukiewicz, Bromowicz, Jawień, Paździora. The methods developed by the latter two authors contributed to rational decisions on the size of mines in Polish coalfields (Jawień in the Upper Silesian Coalfield and Paździora in the Lublin Coalfield).

The mathematical model of a mine developed at the Chief Mining Studies and Design Office in Katowice by a team under the leadership of J. Paździora, which contributed to the introduction of computerized optimization analyses in design practice, is also worthy of mention. A sound concept for determining the optimum size of a projected mine in the conditions prevailing in the Polish coalfields was developed. The optimum output from a very gassy mine is about 12 thousand tonnes per day (Table 5.1) and for a newly constructed non-gassy mine about 24 thousand tonnes per day (Table 5.2). The estimated service life of the mine is about 60–70 years and the mine concession area is from 16–30 km<sup>2</sup>.

Advances made in mechanization of mining work in the postwar period together with the stricter demands of production economics, led to a notable growth in production concentration at the faces, at the extraction levels and,

TABLE 5.1 Production capacity, concession area and planned service life of new gassy mines in the Rybnik Mining Region, Poland

Mine	Net production t/day	Concession area km <sup>2</sup>	Planned service life years
"1 Maja"	8 400	35.6	36
"Jastrzębie"	11 000	16.4	52
"Moszczenica"	12 000	18.6	77
"Manifest Lipcowy"	12 000	16.4	72
"Borynia"	10 000	17.4	65
"XXX-lecia PRL"	15 000	21.4	66
"ZMP"	8 000	14.7	67
"Krupiński"	12 000	16.2	70
"Kaczyce"	12 000	23.6	67
"Pawłowice"	12 000	16.5	53

for mines as a whole. The general modernization of the longwall mining system enabled a multiple increase in production.

The figures shown in Table 5.3, giving the basic technical and economic indices for Polish hard-coal mines, are an eloquent proof of the progress made.

The optimum size of the mine is estimated using the mathematical model. This may be performed at various stages of the design, and hence may refer to the mine as a system or only to its individual elements regarded as sub-systems. The model need not be unnecessarily detailed, but should cover all interdependence between the technical and economic indices.

TABLE 5.2 Production capacity, concession area and planned service life of some new non-gassy mines in the Upper Silesian Coal Basin

Mine	Net production t/day	Concession area km <sup>2</sup>	Planned service life years
"Lenin"	18 000	44.6	100
"Ziemowit"	27 000	62.1	56
"Halemba"	24 000	10.8	46
"Staszic"	16 000	11.99	61
"Piast"	24 000	38.98	66
"Jaworzno"	16 000	39.2	36
"Czczott"	24 000	57.6	40
"Budryk"	20 000	35.57	66

TABLE 5.3 Basic technico-economic indices of hard-coal mines in Poland designed after 1945 and at present

Indices	Unit	Characteristic periods of time				
		up to 1955	1956-1960	1961-1970	1971-1980	now
Mine production (net)	t/day	4000-6000	up to 8000 (up to 8000)*	10000-12000 (6000-8000)*	15000-25000 (about 12000)*	about 25000 (about 12000)*
Average construction time to produce first coal	years	8	7	5-6	4-5	4-5
Average construction time to reach target production	years	12-15	11-13	10-12	6-9	6-8
Construction time for an extraction level	years	8-10	8	5-6	3-4	3-4
Numbers of extraction levels in the mine		2-3	2	2	2	1-2
Production from one level	t/day	1000-2000	3000-4000	5000-8000	10000-15000	up to 25000
Production from one face	t/day	up to 200	300-400	500-1000	1500-3000	2000-4000
Production per loading point	t/day	450	600	1500	2500-5000	4000-6000
Intensity of extraction	t/km <sup>2</sup>	400	500	700	1000-1500	1500-2500
Overall productivity	tOMS	1.55	1.8	2-3.5	3.5-5	about 5
Index of mechanization of coal getting	%	50	50-80	96	100	100

\*mines with high methane emission.



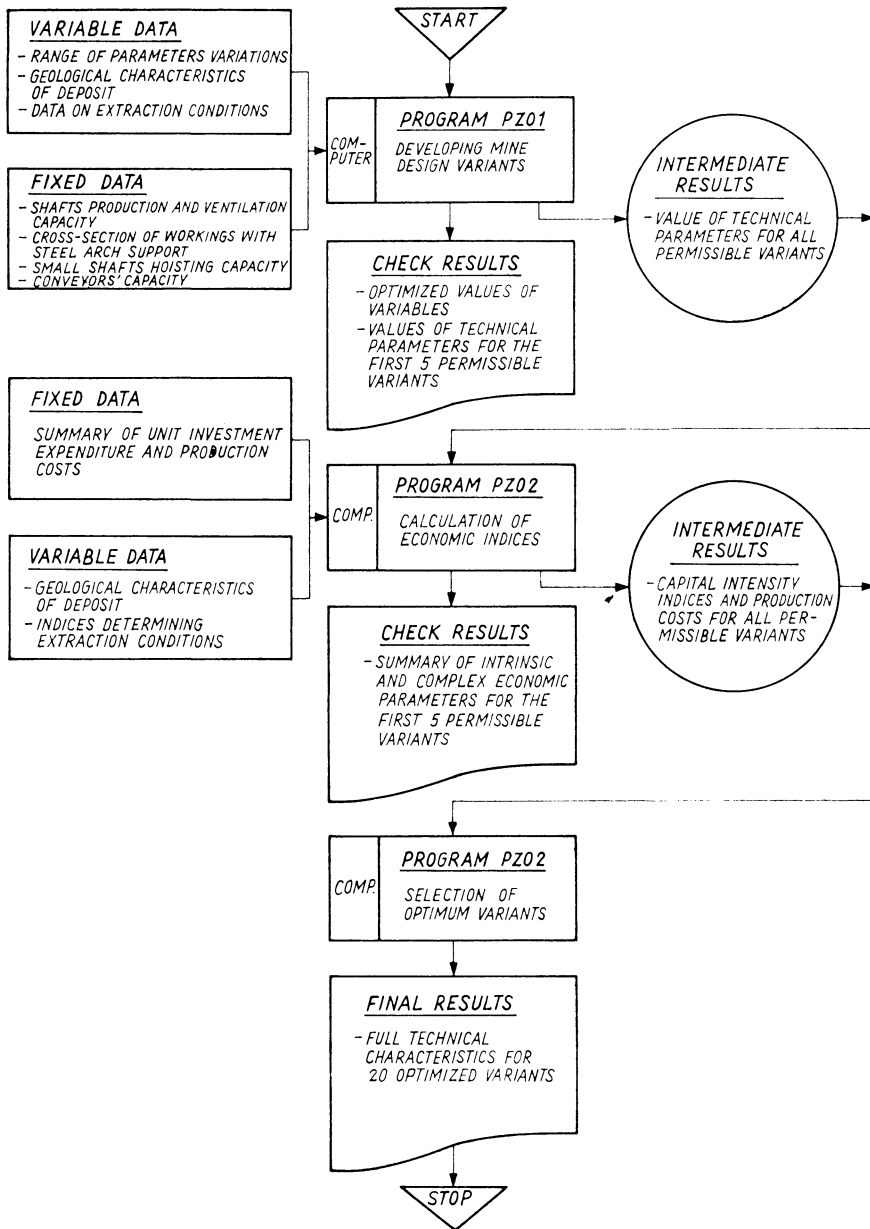

Fig. 5.1 Algorithm for computerized calculations of the mine mathematical model.

*Optimization of the mine size* has to include the optimization of the basic parameters for any deposit with the given geological and mining characteristics.

Maximum economic exploitation of the deposit is included in the mathematical model as the next requirement. About 20 optimum variants are then selected.

Figure 5.1 illustrates the routine for computer calculations of the mine mathematical model.

#### **5.4 Mine Design from the Aspect of Minimum Construction Time**

The length of implementation of the investment project is a primary factor. When constructing new mines (or reconstructing operating mines) solution should be sought which secure the economically most favourable construction time. Naturally this is usually the shortest time, although in some cases maximum reduction in construction time may involve higher costs. Taking into account earlier access to the deposit, and hence its earlier exploitation and shortening of the non-productive period when financial and technical resources are frozen, this approach is advantageous.

To minimize the period of investment implementation, the model of the mine, and especially the model of its underground sector has to be accepted. A simplified structure for deposit first working allows the number of operating levels and the number and length of headings and rooms necessary to develop the deposit and prepare for extraction to be limited. Optimum mining systems must be chosen, such as longwall systems with suitable length and the maximum run of the face ensuring considerable length of the production front. Such systems require fewer time-consuming and expensive first workings, and allow heavy duty equipment to be used which enables concentration of production from the seams. A study of designs for new and reconstructed mines in the postwar years shows a systematic decrease in the number of extraction levels and of development workings. The Polish hard-coal mining industry may serve as an example. In the years 1950–1978 the number of extraction levels dropped from 248 to 161 and the length of development workings per 1000 tonnes of daily production was cut from 27.54 m to 8.31 m, with a parallel increase in yearly production from 78 million tonnes in 1950 to 192.6 million tonnes in 1978. These figures should be analysed in conjunction with the data given in Table 5.3, i.e. total mine production, production from one longwall and from one extraction level, intensity of seam extraction and construction time for an extraction level and for the whole mine. There is

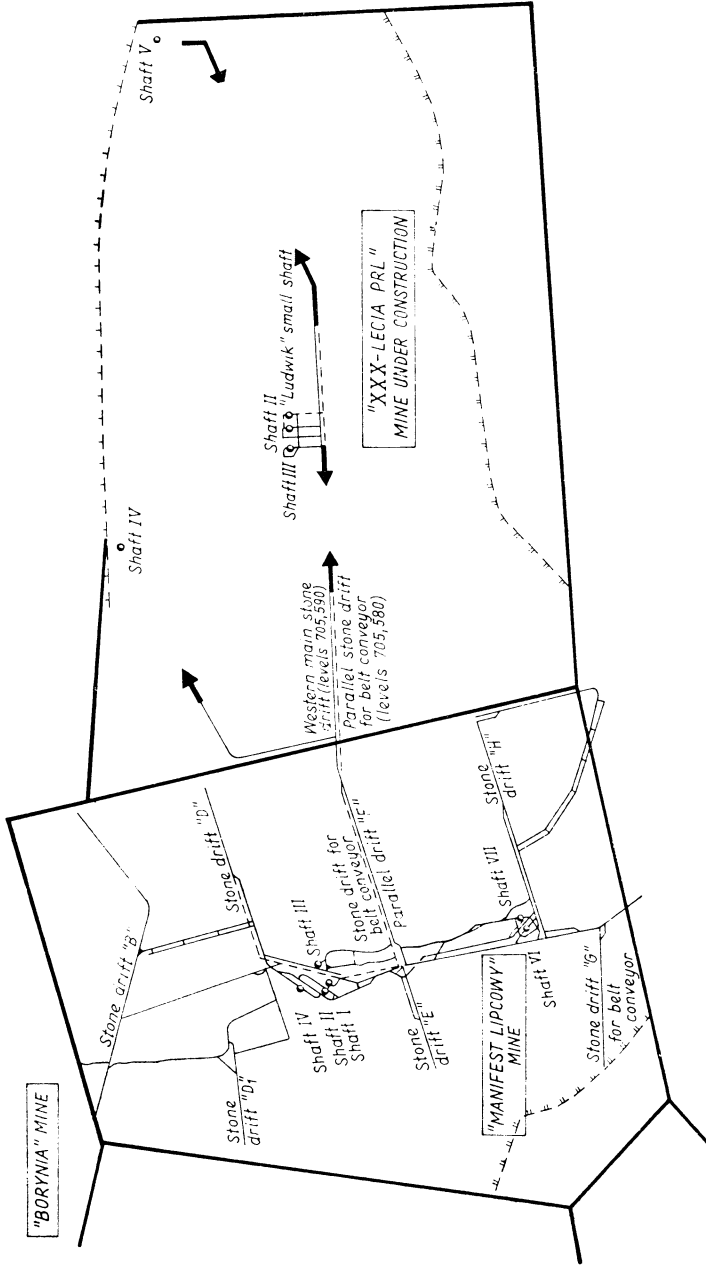

Fig. 5.2 Deposit development at the "XXX-lecia PRL" mine from workings in the existing "Manifest Lipcowy" mine.

a direct correlation between the smaller number of length and underground workings, and shortening of construction cycle and increase in production concentration.

Shaft sinking is the most time-consuming part of the mine construction. It is also the most difficult one to shorten. When complicated geological conditions occur in the overburden it is necessary to apply special sinking methods such as strata freezing or cementation, or the use of tubbing. All this lengthens mine construction time, since it is only after completion of shaft sinking and installing the winding gear, or adapting the previously installed equipment, that work can go ahead to drive the main development workings, cross-cuts, rooms, first workings, etc. However, if there is an operating mine in the vicinity of the planned new mine, then suitable workings may be driven from this mine towards the mining area of the new mine before or parallel with shaft sinking. Opening up the deposit from a neighbouring mine in this way can be very effective in shortening construction time. One of the many examples is the construction of the mine "XXX-lecia PRL" in the Rybnik Coal Mining Region in Poland.

The "XXX-lecia PRL" mine (very gassy) was designed as a single-level mine with first workings driven in the rock. Production of 15 thousand tonnes per day was planned and the deposit was to be developed through three central shafts (production shaft I, man-riding and materials handling shaft II, ventilation shaft III) and two peripheral shafts (ventilation shafts IV and V). According to the design (Fig. 5.2), the development work was carried out from the existing mine "Manifest Lipcowy" (from levels 580 and 705) parallel with the sinking of shaft I, II and III from the surface. The main galleries for the extraction and ventilation levels were driven from "Manifest Lipcowy" mine towards the three simultaneously sunk central shafts and peripheral shaft IV. These galleries were also utilized for cutting out the extraction panels necessary for the first production and for the development of the production front in the western part of the deposit. Construction was started in 1970, the first coal was produced in 1974 and the production capacity was reached in 1981. The construction time was thus shortened by about three years. Similar effects were achieved at the "ZMP" mine in the same region (production capacity 8000 tonnes per day), where the deposit was developed from galleries driven from the neighbouring mines "Borynia" and "Janowice" (Fig. 5.3).

In both cases the depth of levels in the operating and in the new mines was more or less the same. When there are considerable differences in the depth of levels and the depths cannot be developed by horizontal workings, inclined workings are used for deposit panelling of the new mine. The "Piast"

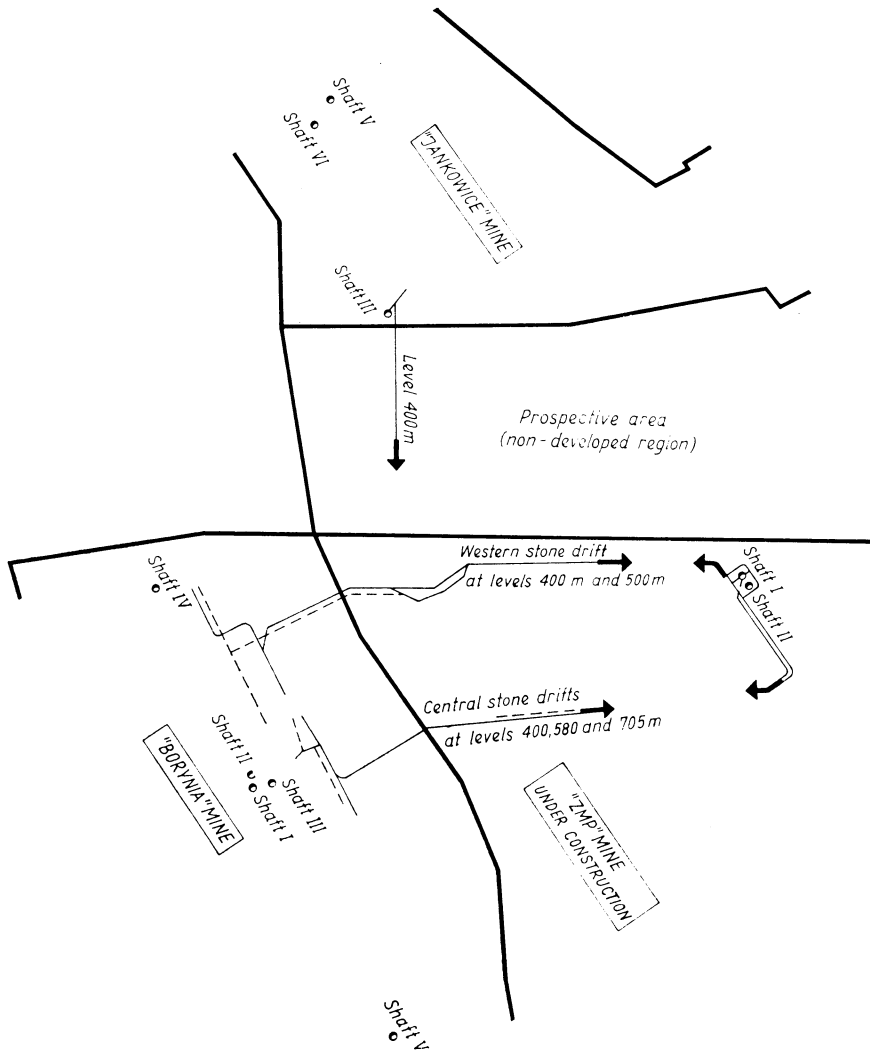

Fig. 5.3 Deposit development at the “ZMP” mine from workings in the existing “Borynia” and “Jankowice” mines.

mine with a production capacity of 24 000 tonnes per day is the best example of this method. Here the deposit was cut out from the neighbouring operating mine “Ziemowit” through four inclined drifts. The construction cycle of the “Piaś” mine was shortened in this way by 3.5 years.

Other organizational and technical measures are also applied to shorten the construction cycle of a new mine or the reconstruction of an operating mine.

One of the main items in an investment undertaking is the construction of the winding system and shaft tops. The construction of these facilities has a direct and significant influence on the time of mine construction or reconstruction. Results of studies conducted have led to modern design and implementation methods including:

- construction of all-purpose headframes to be used both for the development and extraction of the deposit
- shaft sinking from the final headframes, using the final winding gear
- development and implementation of a technology for shifting of headframes and associated buildings and other shaft-top facilities from the assembly site to final location
- development of a method for replacement of winding installations in operating mines with minimum interruption of shaft operation.

The construction of all-purpose headframes and their adaptation for shaft sinking (using buckets) during the development working stage (when shaft cages and mining cars are used) represented the first task to be solved. In the nineteen sixties all-purpose headframes were designed and utilized for shaft sinking and deposit panelling, employing buckets of 2.3 and 4 m<sup>3</sup> capacity. The following types were commonly used:

- single-way headframes for shafts of up to 6 m diameter
- dual-way headframes for shafts of up to 8 m diameter.

Simultaneous sinking of the production shaft and construction of the shaft-top bunker is currently used in Poland. In the example shown in Fig. 5.4, the shaft was sunk to a depth of some 720 m. The shaft sinking operations were then stopped and the shaft was prepared for excavating shaft-side workings at depths from 620 to 706.5. Working from the shaft bottom, in the first sequence a skip pocket (10) was excavated in the concrete lining and a roadway with yielding steel-arch support was driven linking the skip pocket with the chamber (8) not yet constructed. Later the following facilities were installed in the shaft:

- protection stage at depth 613 m
  - loading stage (2) at depth 620 m
  - safety stage (3) at depth 625.5 m
  - vertical partitions between the bucket ways at depths from 613 to 625.5 m and from 655 to 672 m
  - stage for personnel alighting and for materials handling at depth 620 m
  - protection stage at depth 655 m
  - working stage (2) at depth 669 m
  - safety stage (3) at depth 672 m,
- and a discharge chute in the skip pocket (10). After constructing these stages

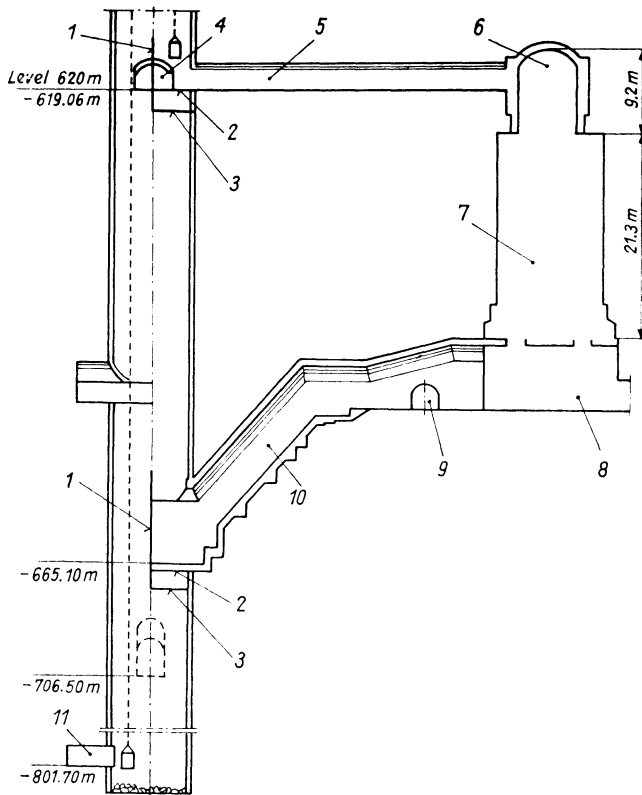

Fig. 5.4 Shaft sinking with simultaneous driving of galleries and construction of coal bunker; 1—partition; 2—working stage; 3—safety stage; 4—shaft double entry; 5—gallery; 6—discharge chamber; 7—coal bunker; 8—chamber under the bunker; 9—contactor room; 10—skip pocket; 11—ventilation duct inlet.

and the chute, shaft sinking was continued and driving of the roadway (5) was started. From this roadway a chamber (6) over the bunker (in the concrete lining) 19 m long and 6.7 m wide and 4.3 m high was constructed. Also from roadway (5), reaching as far as the future bunker (7), an 800 mm diameter hole was drilled near the bunker axis through the chamber (6) over the bunker. This hole was intended for off-loading the gotten during excavation of the bunker. After installing a scraper to remove the gotten to the chute in the skip pocket, excavation of bunker (7) was commenced working from the top. The bunker, located at a distance of 41.4 m from the shaft, has a diameter of 10 m (inside lining diameter), a depth of 16.4 m and a concrete lining of thickness 50 cm.

The gotten was loaded into the bucket at the loading platform (2) at level

669 m. The crew and materials required for the construction of the bunker were delivered from the surface to the working platform at level 620 m in a bucket. Having completed the bunker, the chamber (8) under the bunker was constructed, including reinforced concrete roof plate and a contactor room (9). Simultaneous sinking of the shaft and the construction of the shaft-side coal bunker saved 9 months, while complying with all the required safety regulations.

For many years it has been standard practice to build certain facilities at temporary sites and then shift them to the final design location. This applies particularly to headframes with their full mechanical and electrical equipment. The headframes complete with full equipment are assembled at the auxiliary site (as close as possible to the final location) and then shifted to the final site. While the assembly goes ahead at the auxiliary site, shaft sinking or reconstruction work in the shaft takes place. Having finished this work, the headframes and the winding gear used for shaft sinking is dismantled and the final winding installation moved into position over shaft. Special platforms of suitable construction are used, rolling the final winding installation over a specially constructed track, making use of multirope or hydraulic systems (now mainly hydraulic). This method has been used to move headframes nearly 100 m high and of total weight over 5000 tonnes over a distance of more than 70 m.

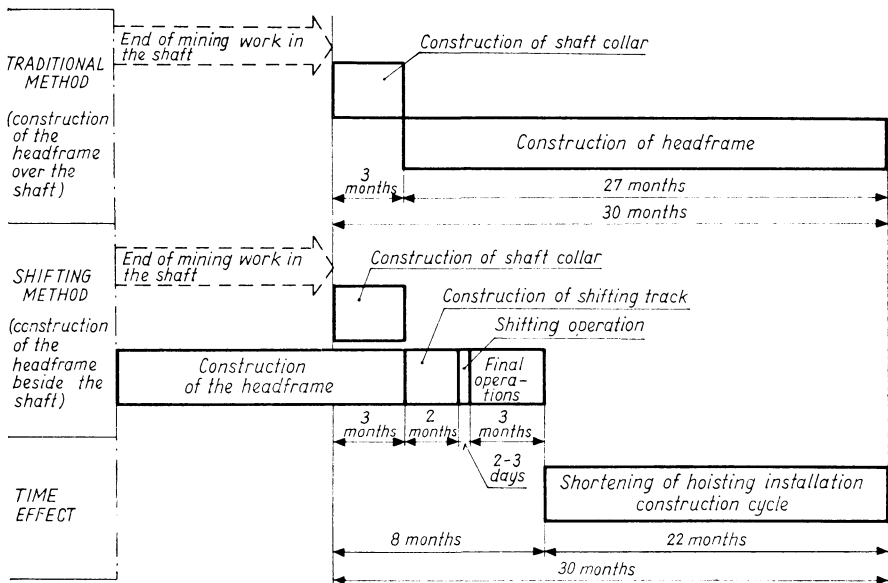

Fig. 5.5 Comparison of headframe erection times by the traditional method and the shifting method (as shown on Fig. 5.6).



Figure 5.5 gives a comparison of a construction cycle for a winding installation using traditional methods, with that when assembling at a temporary site as shown in Figure 5.6.

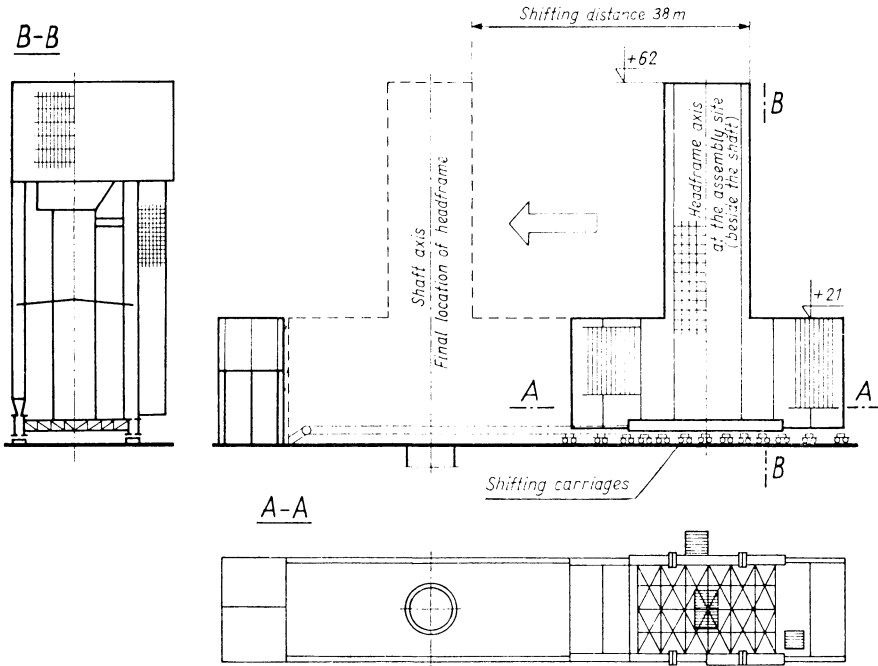

Fig. 5.6 Scheme for shifting of headframe assembled 38 m away from the shaft.

A method for shifting the headframe together with other shaft-side installations (Figs. 5.7 and 5.8) or other facilities (Fig. 5.9) is also used. This method was used for the first time in Poland at the “XXX-lecia PRL” mine. Two headframes with shaft-top installations were moved (1730 tonnes for a distance of 58 m and 2770 tonnes for a distance of 57 m), also two shaft top buildings were shifted (187 tonnes for a distance of 58 m and 444 tonnes for a distance of 57 m) together with a lamproom (2040 tonnes for a distance of 52.5 m).

When planning this type of operation it is essential to synchronize all the work involved in such a way that the temporary occupation of the site for assembly and shifting of the installation does not hold up the construction of other facilities and does not increase the total mine surface area.

Due to the shifting of finished structures, the time for erection of winding installations has been shortened by about 13 to 22 months in the case of tower-type headframes and from 15 to 18 months for trestle-type headframes moved together with shaft-top buildings.

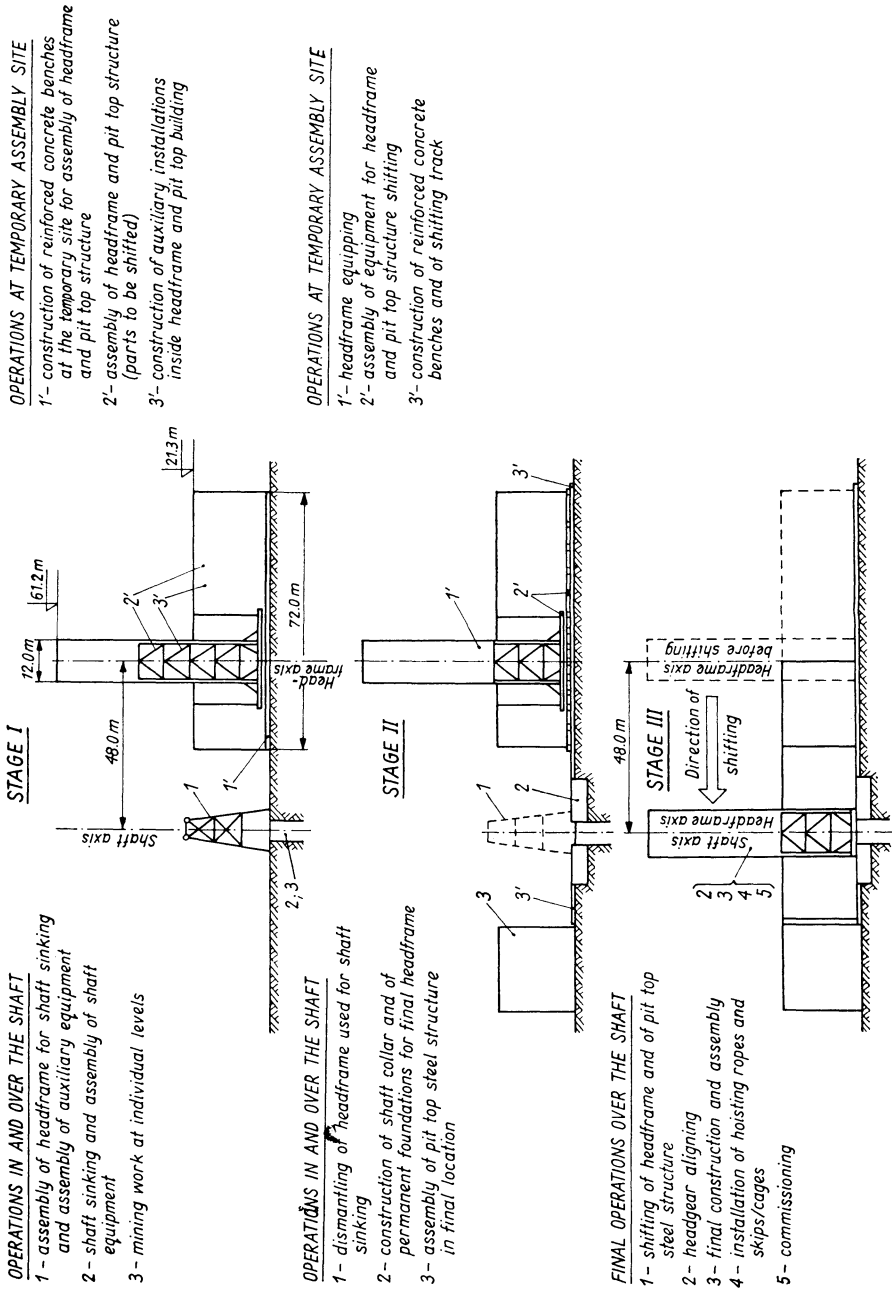

Fig. 5.7 Assembly and shifting of headframe including pit top building. Shifted weight—4 250 tonnes, shifting distance—48 m.

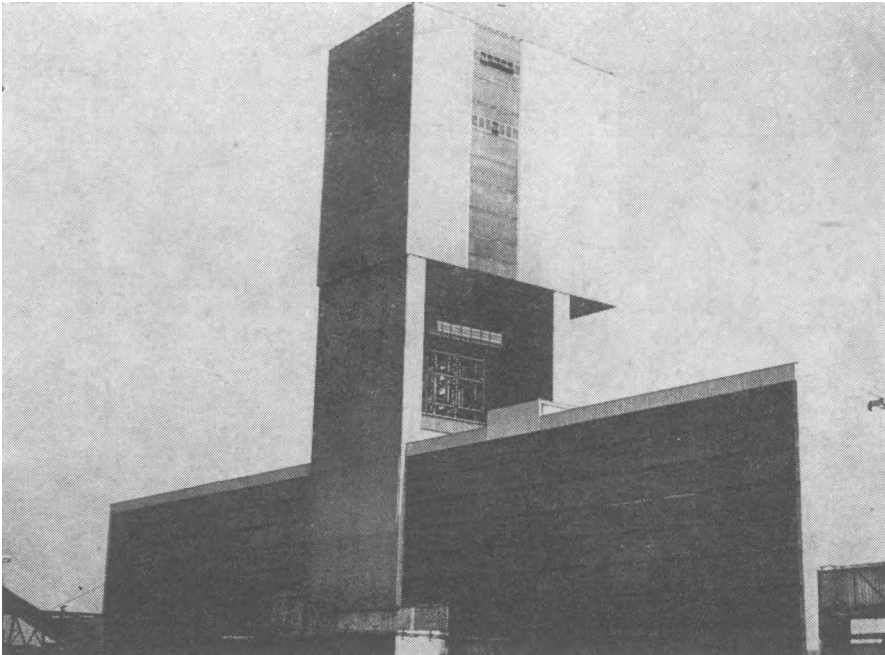

Fig. 5.8 The headframe and pit top of No. 2 shaft at the "Krupiński" mine, Poland, assembled and shifted as illustrated on Fig. 5.7.

The time factor depends on local conditions and the feasibility of applying the various methods.

The assembly of the final production headframe before commencement of shaft sinking can also save time. Shaft sinking is carried out with the help of a specially adapted production winding gear. Having completed sinking and lining of the shaft, the temporary equipment is dismantled (buckets, rope guides, shaft stages) and the guide column of the headframe is assembled. Ropes and winding skips/cages are installed and the winding gear adapted for normal operation. The total length of time for all these operations does not exceed six months, so that nearly two years are saved overall.

A properly planned layout of workshop and storage facilities for subcontractors at the building site is another important factor. During mine construction a number of specialist enterprises are present at the site, each with its own workshop and storage facilities. Experience shows that each subcontractor tries to locate these in the most convenient place from his own point of view. Often such buildings hinder the free movement of building equipment belonging to other subcontractors. A temporarily vacant side may be taken

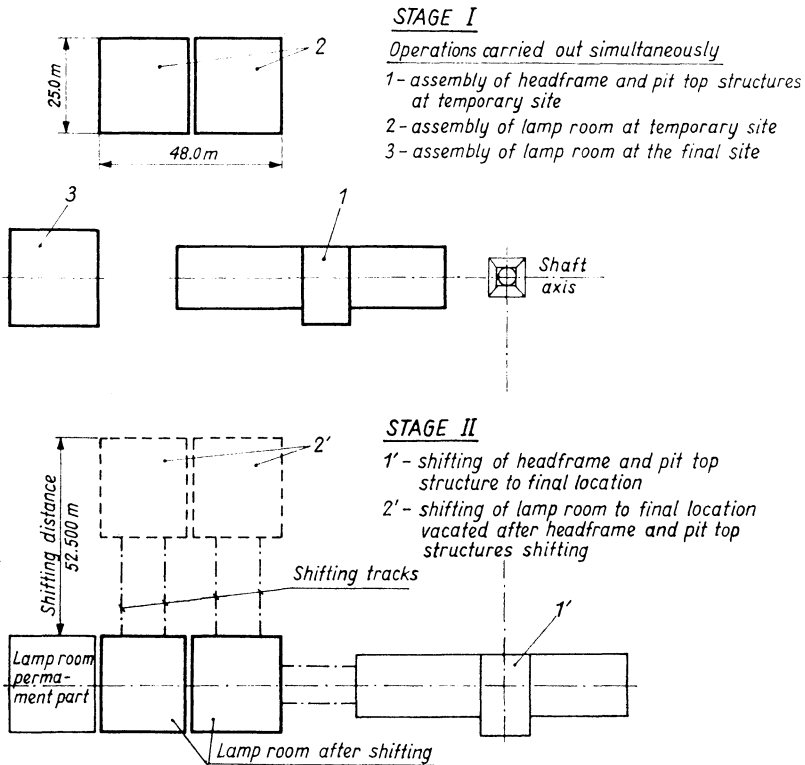

Fig. 5.9 Assembly and shifting of the headframe including pit top building and lamp room. Shifting distance 48 m (headframe and pit top building) and 52.5 m (lamp room)

over although scheduled for future development. Several cases have been known where during the mine construction it became necessary to resite certain facilities or to use equipment other than that called for in the design; some buildings constructed earlier had to be demolished and re-erected on a new site. All this adversely influences the time schedule and increases costs. It may be avoided by correct planning (allowing for external access roads and internal site transport), as in the example shown on Fig. 5.10. Light, standardized buildings of industrial shop type are erected, easy to construct, with low costs and labour requirements. Each subcontractor (I to X) is allotted accommodation suited to his actual needs. Nearly all these facilities (about 90%) were afterwards re-used in another new mine.

Application of standard and typical designs plays a very important part in minimizing investment time and the following results are achieved:

— cutting down time required for preparation of design drawings

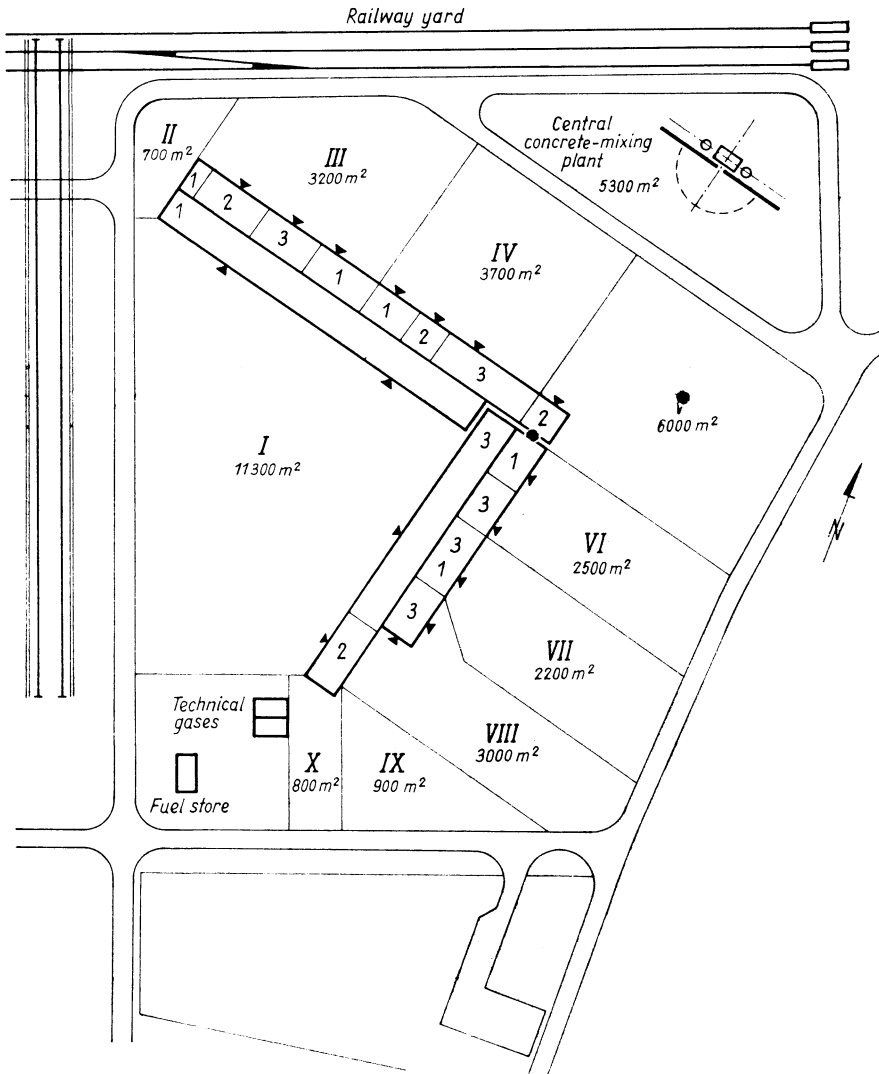

Fig. 5.10 Centralized construction facilities for subcontractors, 1—stores, 2—workshops; 3—roofed area, I—X—areas and facilities for individual subcontractors.

- rationalization of mining work organization and technology, especially in standard design underground workings
- shortening construction time for mine surface facilities
- more efficient installation of technological equipment
- reduction in materials consumption, building costs and equipment manufacturing costs.

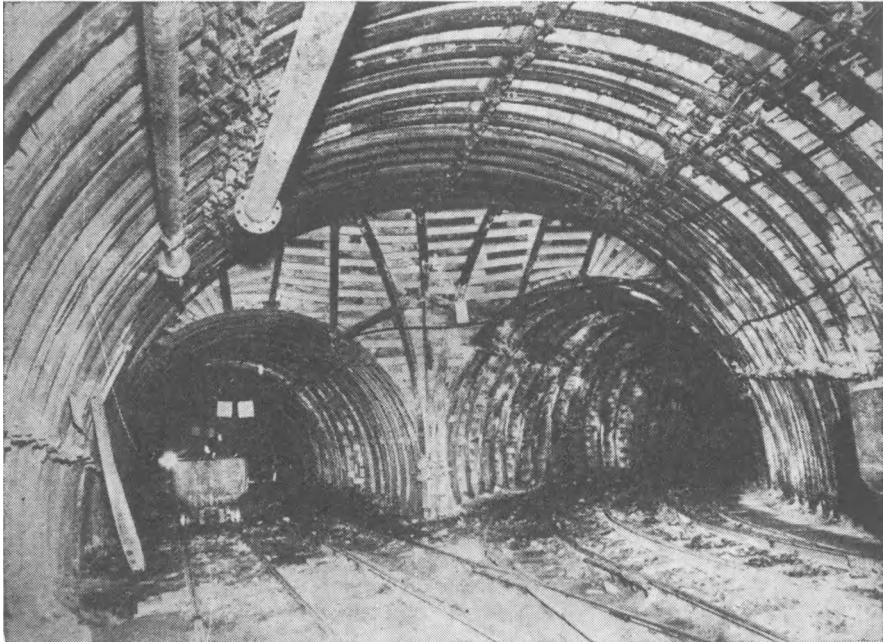

Fig. 5.11 Standardized roadway including roadway crossings.



Fig. 5.12 Standardized underground railway station.

Due to the use of typical standard designs it becomes possible to design a mine by the “catalogue” method. Here the constructor, knowing the required duty and overall imposed parameters of the given facility, selects suitable standard components and systems and verifies his choice by computerized calculations. In the Polish mining industry an advanced degree of standardization has been developed in the following:

- roadway workings, where cross-sections are standardized depending on installed equipment, type of support and method of solving roadway junctions (Figs. 5.11 and 5.12)
- room workings such as explosives stores, trolley and battery locomotive sheds (Fig. 5.13), battery charging rooms, main-drainage pump-rooms including water galleries (Fig. 5.14), 6 kV main and district switchboard rooms, fire fighting stations, first aid rooms, etc.

Typical design series have also been developed for equipment used in the winding system and for certain underground equipment. Diameters of shafts and auxiliary shafts have been standardized. In skip shafts standardized skips of capacity up to 30 tonnes are used and standardized cages are used in cage shafts.

In the underground area, typical technological systems have been developed

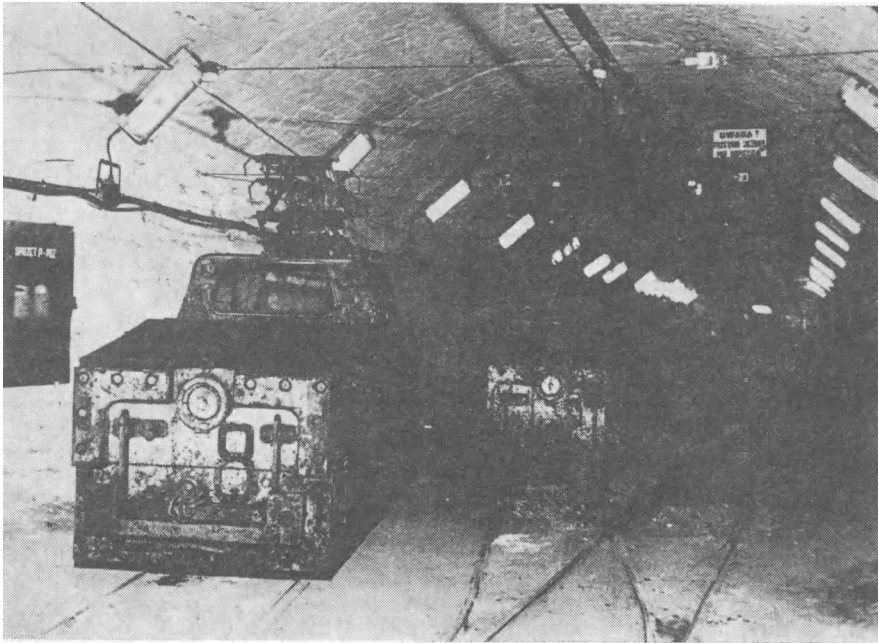

Fig. 5.13 Standardized trolley locomotive workshop.

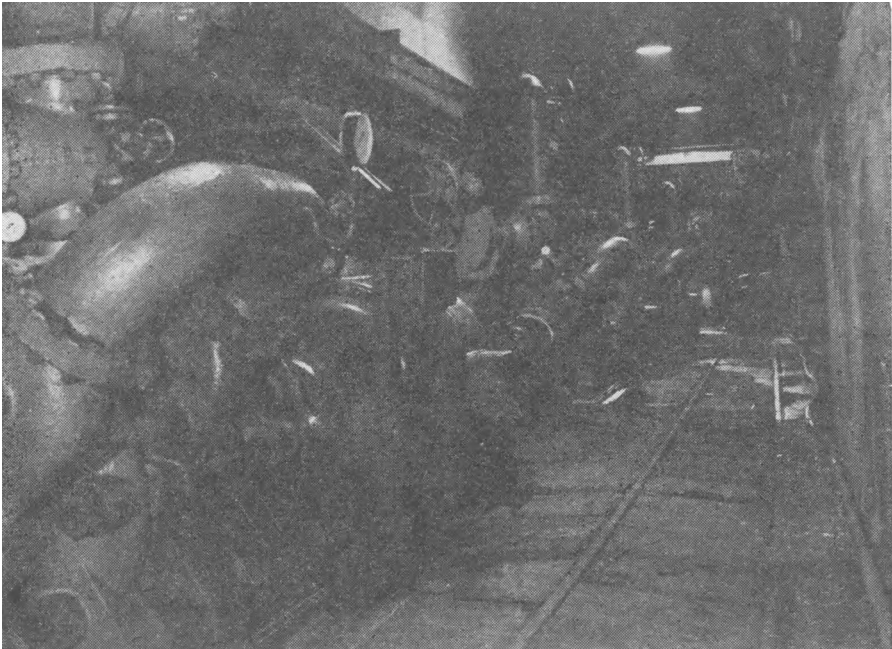

Fig. 5.14 Standardized main drainage pump room.

for shaft side facilities: balance platforms, car grippers, car pushers, track brakes, water, ventilation and safety stoppings.

Good results have been obtained in developing standard designs for electric power supply. The components are based on repeatable designs while most of the high and low voltage distribution equipment is prefabricated by the contractors to typical design documentation.

The system of dispersed development of the mine surface found in the older mines has been replaced by the block development and grouping of surface facilities in functional zones. In this way surface development shows a favourable proportion between area occupied and cubic capacity of the industrial facilities. This also gives straightforward and functional communications and technological routes. In mines where the block system has been introduced the developed site area has been reduced on average from 6.0 to 3.5 ha per 1000 tonnes of daily coal production and the cubic capacity of buildings from about 50 000 to about 30 000 m<sup>3</sup> per 1000 tonnes of daily coal production.

The rationalization described above allows the construction period to be reduced by some 50–60%. For example, during the construction of the “Piast”



mine, an administrative-social complex of about 80 000 m<sup>3</sup> capacity was completed in 37 months, the block principle being applied not only to baths, lamp rooms and miners' assembly hall with record offices but also administrative offices, dispatch room, telephone exchange, industrial guard station, gate house, laundry room, first aid point and technicians' club with library. The complex was constructed from prefabricated typical elements.

The coal preparation plant is the most important component due both to cubic capacity and function, especially in coking-coal mines. During the last 30 years substantial progress has been made in Poland in the design and construction of coal-preparation plants. The effectiveness of coal-preparation has increased while investment costs and construction times have been cut. This is discussed in more detail in Chapter 7.

The following conclusions may be drawn:

1. Optimum shortening of the construction cycle can be implemented at any stage of design. This may be achieved by careful preparation of complex development plans for the mining regions, developing a suitable mine model and making use of standardized components for the construction of surface facilities.
2. Considerable time saving may be gained by direct development of the deposit from workings driven from a neighbouring operating mine.
3. Adapting a collective mine model allows a reduction in number of shafts, cubic capacity of underground and surface facilities and allows the mine to be commissioned in stages.
4. The length of time required to construct surface facilities depends on the surface layout scheme and the technologies applied for this construction. The use of up-to-date technologies such as shaft sinking from the final production headframes and winding installation, building of headframes and shaft-side facilities at auxiliary sites and moving them to the final location later can substantially shorten construction time for the whole mine.
5. Improved organization of construction work saves time. Lattice methods which by indicating the "critical path" permit an analysis of operations bearing directly on the final date of investment implementation are valuable. They also permit an accurate analysis of costs incurred due to more rapid construction work.
6. Optimization of mine construction is vitally important in meeting the escalating demand for coal throughout the world.

## Chapter 6

### Planning the Development of Coal Mining Regions

#### 6.1 Basic Definitions

An area with coal deposits which forms a separate geological unit is called a *coal basin* (e.g. the Upper Silesian and Lublin Coal Basins in Poland, the Donets Coal Basin in USSR, the Saar Coal Basin in FRG). A *coal region* is a part of a coal basin distinguished from the rest of the basin by its geographical location or some other feature (e.g. the Rybnik Coal Region in the Upper Silesian Coal Basin). Areas with specific geological-mining conditions geographical location or various characteristics of coal occurring there are called *coal mining regions*. If other mineable minerals such as crude oil, metallic ores, chemical raw materials, rock materials are present, the area is called a *mining region*.

A coal mining region is the term given to a part of a country in which a group of mutually linked units of production potential is concentrated and where coal production and processing plays a dominant role. In the coal mining region the mining-geological parameters are similar, as are the mechanical and chemical properties of the coal and accompanying minerals, making it possible to develop a unified model and optimum size for a mine design.

Complex development of a coal mining region involves establishing guidelines for the development of coal mining as the basic local industry. The total infrastructure of the region including utilities and services, social welfare, communications and transport facilities, etc., is also developed. Modernization and extension of the existing mines and the construction of new mines in the given coal mining region should form a part of an overall complex technical and economic development plan for the whole region.

Development of new coal regions in Poland can serve as an example. In the post-war period (1945–1983) 20 new hard-coal mines were opened in Poland,

that is, 10 mines in already developed regions of the Upper Silesian Coal Basin, 9 mines in the new Rybnik Mining Region and the first mine of the currently developed Lublin Mining Region. Further mines are in the planning stage. During this period all the operating hard-coal mines have been reconstructed and modernized. The coal industry, which governs the character of the new community being formed, tends to create a strongly industrialized agglomeration which inevitably represents a severe threat to the natural environment. The protection of man's natural environment is given the top place in all plans for coal mining regions. The mining design office (Chief Mine Studies and Design Office, Katowice) which prepares projects for the development of coal mining regions both at home and abroad, and cooperates with the relevant research institutes, considers all known technologies for coal winning and preparation. A management model for the whole region is developed for each individual project making use of the most up-to-date computerized and mathematical methods.

The current world fuel and energy situation demands the most effective utilization of energy raw materials. The Polish school of mining design has considerable experience and can claim scientific as well as practical achievements. The broad investment program that has been implemented in the Polish mining industry, and the successful investment projects realized in many other countries, confirm this.

## **6.2 Methodology of Planning Coal Mining Regions**

Complex development of coal mining regions, involving both time and spatial plans, is one of the design methods used in Poland. Complex development aims to achieve:

- optimum utilization of deposits of coal and accompanying minerals occurring in the region
- adequate development of industrial and social infrastructure by construction of services facilities, social welfare amenities, communications network, water-sewage system, power supply, etc.
- development of associated industries, particularly those which are traditionally linked with the region
- a long-term plan for an educational system for different levels and specializations based on manpower requirements and the creation of jobs for various employment groups
- protection of the natural environment
- a time schedule for the implementation of investment and for production development, based on long-term predictions for advances in mining

techniques and applying methods for analysis of investment effectiveness.

To achieve these goals it is necessary to find a complex solution to three groups of technical problems:

- division of the deposit into production units (mines) and preparation of a model for development and extraction
- designing the layout of the surface sector
- spatial development of the region, bearing in mind the interests of the coal mining industry and the whole technical and social infrastructure.

The first group of problems, which may be called the *design for mining development of the deposit*, comprehends determination of the optimum mine size, model and structure. Analytical methods of mine design used in the fifties have been markedly improved due to the introduction of computer techniques.

Complex optimization of the principal parameters of the mine and its individual elements was realized by developing the basic mathematical model of the mine. With the help of computers it is possible to monitor and evaluate the technical and economic indices corresponding to several hundred or even several thousand variants of the mine model and mine structure.

Depending on the nature of the input data, the mathematical models are divided into determinist, probability, statistical and strategic types.

In the *determinist models* every input parameter is precisely determined, i.e. its value (or nature) is known and invariable and each decision corresponds to one function of the objective. Each produced solution is reliable from the theoretical point of view.

If, however, even one model input parameter is a random variable of considerable distribution, then the model becomes a *probability model*.

In *statistical models* one or more parameters are random variables of unknown distribution, or with known distribution but varying with time (*stochastic models*).

If we know that one or more input parameters may have one of many values within a known set, then this is a *strategic model*.

Determinist models were virtually always used until quite recently. Practice showed, however, that reality often diverges from the design situation due to the random variation of certain parameters. This could be the geological state of the deposit, which at the design stage is not sufficiently known, particularly in the case of a deposit not previously developed. As a rule an element of doubt or risk is present. In such cases the probability models prove to be more useful than the determinist ones. The progression from determinist to probability models has facilitated a notable advance in design theory and practice.

In the method of complex development of coal mining regions the first priority is the speeding up of the target time for reaching production. This may be achieved by development of the mining region in stages, so that the coal production increases steadily, the construction time for each individual mine is the shortest possible. In general the mining and geological conditions in each sector of the given coal mining region are the same or similar. If this is so and several mines are to be constructed in this region, it should be possible to adopt the same or similar model of deposit development, to utilize standardized designs, equipment and machinery and to plan for joint use of certain facilities (roads, railway sidings, service shafts, electric power network, water system) both underground and on the surface. This can give substantial economies in time and costs of designs as well as in construction time and investment expenditure. The correct sequence of construction may considerably shorten the construction time due to the feasibility of mutual help in developing the neighbouring concessions. In this case the same or similar depths of extraction levels should be scheduled in the development designs for the neighbouring mines. From a mine already constructed it should then be feasible to excavate development cross-cuts for a new mine simultaneously with shaft sinking and other development work, as described in Section 5.4 and illustrated in Figs. 5.2 and 5.3.

TABLE 6.1 New hard-coal mines in the Rybnik Coal Mining Region (at the end of 1983)

Mine	Year of starting		Planned capacity t/day		Year of reaching target production
	construc- tion	extrac- tion	initial	present	
"1 Maja"	1952	1960	3600	8 400	1972
"Jastrzębie"	1956	1963	4000	11 000	1980
"Moszczenica"	1957	1963	4000	12 000	1974
"Szczygłowice"	1957	1961	6000	20 000	1980
"Manifest Lipcowy"	1961	1969	8000	12 000	1976
"Borynia"	1968	1971	8000	10 000	1976
"XXX-lecie PRL"	1970	1979	8000	15 000	1981
"ZMP"	1974	1979	8000	8 000	1983
"Krupiński"	1975	1983	12 000		1986
"Kaczyce"	1978	1984	12 000		1987
"Budryk"	1978	1985	20 000		1993
"Pawłowice"			12 000		

A practical example of this procedure is the development of the Rybnik Coal Mining Region in Poland, where in 1952–1983 nine new mines of target capacity 108 400 tonnes per day have been constructed and commissioned, while two more mines are under construction (32 000 tonnes per day) and the twelfth mine is in the design stage (Table 6.1). All these mines were, or are being constructed in a new region not previously developed for mining, where the deposit has a high methane content.

Rapid advances in mechanization have brought a significant increase in concentration of production. The largest non-gassy mines built in Poland have a production capacity of 24 thousand tonnes per day (Fig. 6.1) and 27 thousand tonnes per day (Table 5.2). Currently mines of even higher production capacity are being designed. Such advances naturally influence the design and layout of the mine surface.

The second priority is the development of the mine surface sector which is directly related to the accepted model of the underground sector. The object is to simplify the design and reduce the area of the surface layout with maximum utilization of standard structural components. Modern designs achieve considerable simplicity due to the centralization of many technical, industrial, social and cultural-recreational functions for all the production

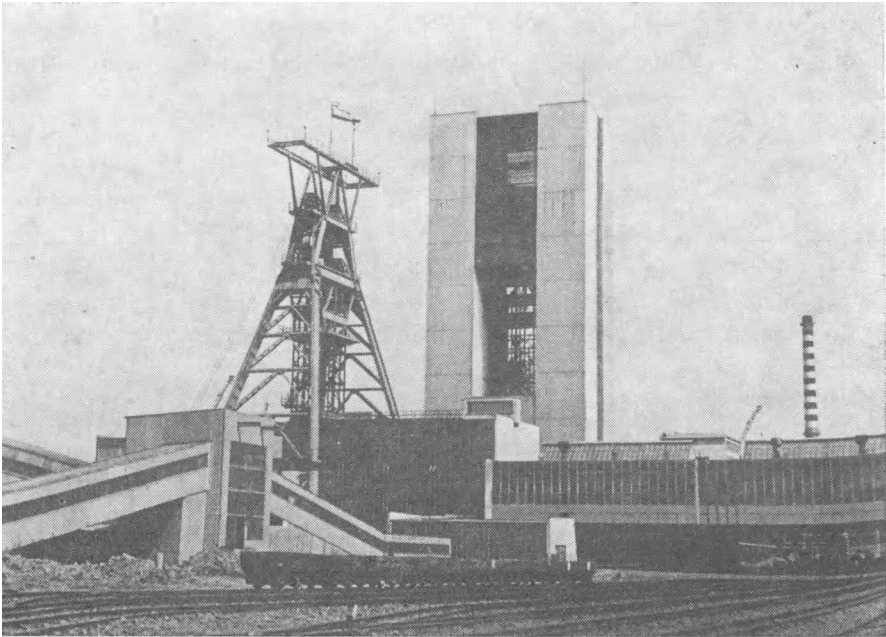

Fig. 6.1 View of the "Piast" mine. Nett production 24 000 t/day.

units and their personnel. Studies on the application of probability methods for developing overall guidelines for the design of the mine surface are already far advanced.

The third group of technical problems comprehends investment projects for spatial development of the region. They result directly from the overall plan for mining development of the region and the infrastructure requirements. The following facilities or their groups may be listed:

- ancillary industrial complexes serving all the mines of the region
- central or group preparation plants for coal and other raw materials (serving all or a group of mines in the region)
- central industrial service facilities for all the mines (repair workshop, stores, etc.)
- subcontractors' workshops and facilities
- communications, power, water/sewage networks, etc.
- housing, social and services facilities, schools, etc.

### **6.3 Examples of the Development of Coal Mining Regions in Poland**

There are three hard-coal basins in Poland, i.e. the Upper Silesian (Katowice), Lower Silesian (Wałbrzych) and Lublin basins. The Lower Silesian coal basin is totally developed and has presently no development prospects. The Lublin basin is currently being developed and shows good prospects. It is described in detail in a later chapter.

In the Upper Silesian coal basin, which is the biggest in Poland, four coal mining regions (Fig. 6.2) may be distinguished: the Central, Rybnik, Mińsk-Źródło-Pszczyna and Kraków regions. Developed mining areas (operating mines and mines under construction) and areas scheduled for future development are in each of them. Most intensive development is seen in the Central Mining Region and the least in the Kraków Coal Mining Region.

In the Upper Silesian Coal Basin, the Central and Rybnik Coal Mining Regions are the largest and are already developed. The methods applied here, especially in the case of the Rybnik Coal Mining Region, are the best example of the Polish school of design for the development of coal mining regions.

#### *6.3.1 Development of the Central Coal Mining Region in the Upper Silesian Coal Basin*

The yearly production from this region has already passed the 100 million tonnes mark. After nationalization of the coal industry in Poland this region was restructured. Many small and old mines, threatened by closure due to

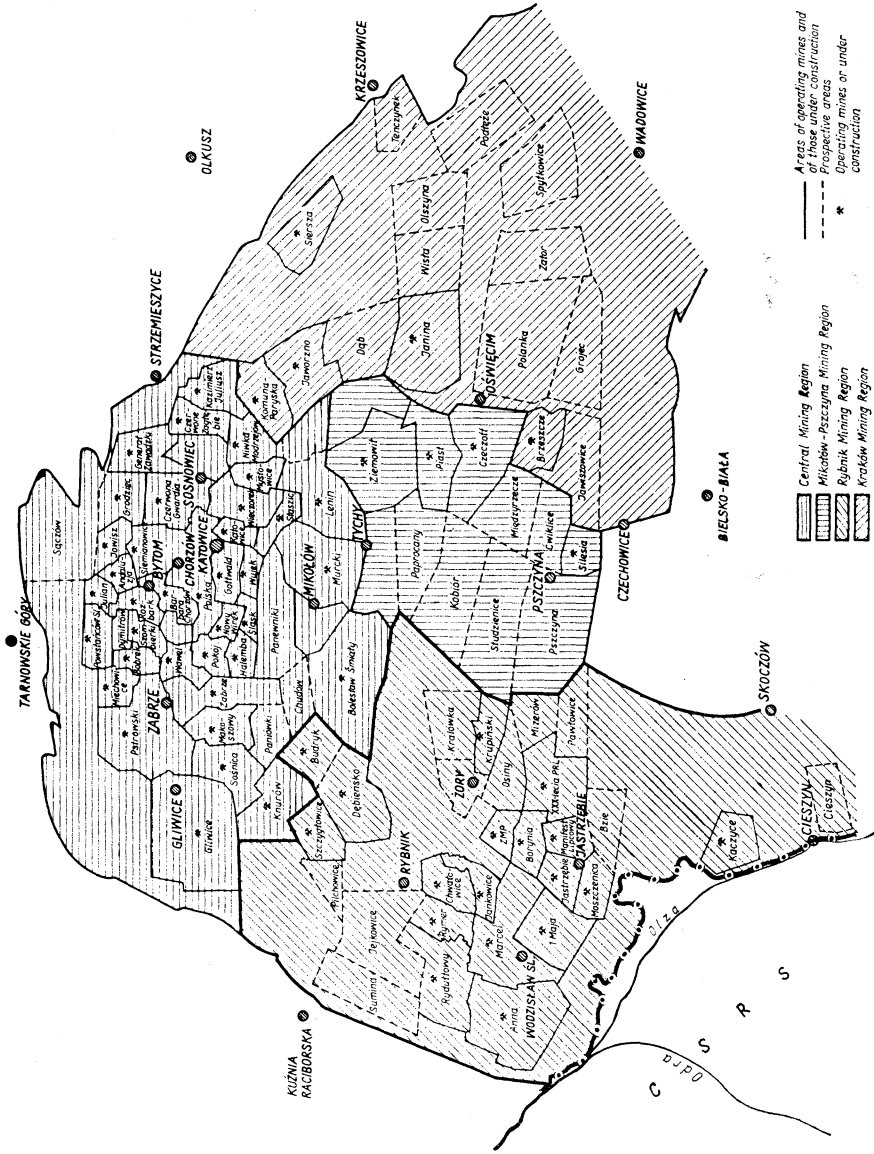

Fig. 6.2 Upper Silesian Coal Mining Basin. Mining regions, operating mines, mines under construction, prospective mining areas.



the exhaustion of reserves within the boundaries of the old mining leases, were merged to achieve more rational exploitation of the deposit. Mining operations were extended to coal left in safety pillars, under towns and other surface structures, to shaft pillars and reserves located at depths below 1000 m. Improvements in methods of mining out safety pillars avoided the closure of many mines in towns such as Bytom, Chorzów, Katowice and Zabrze and allowed production from these mines to be systematically increased. Table 6.2 shows the quantity of coal extracted from support pillars in years 1963–1983 and its share in the total production of hard coal. It is interesting to note the proportion of this production corresponding to different extraction methods (caving, hydraulic stowing, dry stowing). Extraction with hydraulic stowing requires about 220 thousand tonnes per day of stowing material, supplied mainly from open-cast sand pits. Sand is transported by a separate

TABLE 6.2 Production from support pillars and its share in total hard-coal production in Poland

Year	Winning system						Total	
	with caving		with hydraulic stowing		with dry stowing		thousand t	%
	thousand t	%	thousand t	%	thousand t	%		
1963	—	—	—	—	—	—	16 029	14.26
1964	—	—	—	—	—	—	19 434	16.7
1965	—	—	—	—	—	—	22 687	19.2
1966	—	—	—	—	—	—	23 196	19.1
1967	14 487	11.8	36 737	29.8	1 784	1.4	53 008	43.0
1968	14 137	11.0	37 205	29.1	1 355	1.1	52 696	41.2
1969	17 501	13.0	36 422	27.1	1 728	1.3	55 651	41.4
1970	17 814	12.7	37 371	26.8	1 764	1.3	56 949	40.8
1971	20 865	14.4	35 948	24.5	1 826	1.3	58 239	40.2
1972	22 780	15.20	36 383	24.27	2 234	1.49	61 396	40.96
1973	25 788	16.56	35 544	23.46	2 002	1.29	64 334	41.31
1974	30 069	18.67	35 841	22.25	2 472	1.54	68 383	42.46
1975	33 970	19.85	36 237	21.18	1 712	1.03	71 919	42.03
1976	37 396	20.92	32 530	18.19	1 828	1.02	71 753	40.13
1977	38 757	20.88	32 240	17.37	1 798	0.97	72 795	39.22
1978	34 001	49.8	27 285	40.1	1 108	1.6	68 278	35.52
1979	41 836	20.85	25 554	12.73	1 354	0.67	75 224	37.48
1980	38 734	20.09	20 530	10.65	1 236	0.64	65 954	34.22
1981	27 214	16.73	16 492	10.14	767	0.47	48 905	30.06
1982	32 185	17.04	19 829	10.50	931	0.49	58 122	30.76
1983	34 429	18.05	21 684	11.37	894	0.47	62 085	32.54

railway network. Coal extraction from support pillars located under towns or other structures (e.g. under the Bobrek Steel Plant in Bytom) represents a significant achievement for Polish mining science, due particularly to Professor W. Budryk.

The transport of coal from the Central Mining Region, reaching over 150 million tonnes per year of which about 85% is sent to consumers outside the coal basin, is of prime importance. Seven railway stations acting as marshalling yards are located on the perimeter of the region. To minimize the number of journeys, linear-programming methods and computer techniques are used. Optimum transport routes outside the coal basin are selected with the help of mathematical models.

Underground mining disturbs the balance of nature, though to a lesser degree than do other industries in the Upper Silesian Coal Basin. Plans for the reconstruction and modernization of old mines and the construction of new mines envisage environmental protection measures, as follows:

- protection of the atmospheric air;
- protection of underground and surface water;
- protection of the soil and the landscape;
- protection of the ground surface and surface structures against mining subsidence;
- water disposal.

To limit excessive emission of smoke, dust and sulphur oxides, fires in spoil tips are extinguished, dust-extractor installations are introduced in industrial plants, and low-efficiency equipment is modernized.

The following methods are applied for the protection of underground and surface water:

- construction of modern treatment plants for industrial and communal effluents;
- prevention of over-salination of surface water by mine water, either by employing desalination of the mine waters (to give fresh water and salt), or by a hydrotechnical method in which there is a controlled feed of the salt water to the rivers via special retention reservoirs
- using closed-water circuits in coal preparation plants
- protecting surface water reservoirs against infiltration from underground sources
- sub-level disposal of flotation and washery slurries in natural surface depressions.

For many years intensive reclamation of spoil tips and recultivation of the soil has been practiced while over-level dumping of waste is strictly limited. Considerable quantities of waste are utilized for dry stowing in old workings.

Barren sandy areas left after sand stripping are treated with fertilizers and recultivated or used as water reservoirs for industry, agriculture, communal or recreational purposes. Areas devastated by the effects of underground mining are recultivated mainly by park and forest tree planting.

Protection against mining subsidence is a serious problem from the technical and also from the economic and social aspects. Preventive engineering has helped to protect surface structures and installations against the effects of ground deformation. When siting new towns, industrial plants, etc., predictions of ground deformation are carefully analysed to select the optimum location. Levelling of ground subsidence is achieved by choice of suitable extraction systems and by stepping up extraction advance in seams of neighbouring mines.

### *6.3.2 Development of the Rybnik Coal Mining Region in the Upper Silesian Coal Basin*

Rybnik lies in the south-western sector of the Upper Silesian Coal Basin (Fig. 6.2) and borders with the Czechoslovakian Ostrava-Karvina Coal Basin. Mining was first started here some 200 years ago and in 1914 there were eight mines, producing 4.4 million tonnes per year in a comparatively small area in the eastern-central part of the basin. In 1938 coal production was about 6 million tonnes, i.e. only 1.6 million tonnes more than in 1944.

Systematic geological prospecting carried out after 1945 indicated a big development potential for this region. The southern and south-eastern parts of the Rybnik lands proved to be particularly rich in coking coal. Planning and design work for the development of this region was started in the early fifties, the strategy covering the whole Rybnik Coal Mining Region. Very shortly work began on the construction of new mines, i.e. "1 Maja", "Jastrzębie", "Moszczenica" and "Szczygłowice", in the northern part of the region (Fig. 6.1 and Table 6.1). The final, comprehensive plan for the development of the Rybnik Coal Mining Region was completed at the end of the fifties and its effects may be seen in the investment projects listed in Table 6.1 (for the end of 1983). Apart from the actual mine construction the plan included investment projects for electric power, heat engineering, water-sewage, road and rail transport, building of towns and settlements, telecommunications, services of all kinds, sport, recreation and culture. Investment requirements, i.e. supply and storage of materials, machinery and equipment, provision of temporary construction facilities were included. The plan also specified the precise order and organization of the investment, detailing the time break-down of the expenditure, and included economic analysis and guidelines

for research and development and constructional-design studies that needed to be carried out.

Implementation of this plan then followed. Seven new mines are sited in close proximity, i.e. "1 Maja", "Jastrzębie", "Moszczenica", "Borynia", "ZMP", "Manifest Lipcowy" and "XXX-lecia PRL" and two further mines "Krupiński" and "Szczygłowice". The final joint production capacity of these mines was fixed initially at 61 600 tonnes and later at over 108 000 tonnes per day. For example, daily production from the "Jastrzębie" mine was initially set at 4 000 tonnes but updated information has raised the target production to 11 000 tonnes per day.

Evidence of progress made in design, mining technologies and winning techniques is provided by the comparison of the planned production from the nine mines (108 400 tonnes per day) with the production achieved from the eight "old" mines operating in the Rybnik area in the pre-war period, i.e. in 1938 with favourable markets, about 6 million tonnes, or 20 000 tonnes per day.

At present (1984), the mines "Kaczyce" and "Budryk" are under construction and designs for the mine "Pawłowice" are still on the drawing board. The scope of the projects undertaken is similar to that for the seven mines already mentioned. The development of further areas is planned for the future.

Boundaries of the mining concession areas are usually natural ones. The depth of extraction levels was coordinated wherever possible with that in the neighbouring mines shortening the construction time for each next mine by driving horizontal workings directly from an already developed mine, as explained in Section 5.4. Shafts (downcast and upcast) were sited at the joint boundary of neighbouring concession areas, thus effectively determining the future location of the mine surface buildings.

The isoline map of surface subsidence was prepared (for the whole Upper Silesian Coal Basin), and a map showing surface development conditions was worked out. This map played a decisive part in delineating support pillars (limit of restricted extraction) and in siting residential estates and towns. An allowance was made for the adverse surface effects of underground mining, which disturbs the natural geomechanical equilibrium, soil conditions and the water regime.

Instead of planning housing projects near to the mines, residential construction was concentrated in larger units.

A good example is the town Jastrzębie (about 100 thousand inhabitants) located in the middle of the newly developed coal mining region at a place

where the Carboniferous lies at a considerable depth thus ensuring suitable conditions for surface structures.

Detailed plans were also prepared and implemented for ancillary projects such as rail transport, heat-and-power stations, electric-power network, communications, water-sewage and gas layouts. The heat and power generating plants at the "Moszczenica" and "Manifest Lipcowy" mines may serve as an example. The plants supply both heat and power for the two mines and also for "Jastrzębie" and "Borynia" and the town of Jastrzębie.

All extracting seams classified as IV category methane hazard in deep mines are required to have three independent sources of electric power supply. A suitable electric network was designed and constructed to comply with both the technical and electrical requirements.

Optimum telephone facilities of the joint-cable type are provided for the individual mines to ensure reliable communications with other mines and their exchanges, with the internal coal industry and national networks.

Water pipeline networks were designed and installed to supply drinking and industrial water to the mines and to carry off salt underground water. Mechanical-biological plants treat effluent from the individual mines. Pipelines draining salt underground water to retention-controlled reservoirs, and eventually to the river Odra, were provided.

The industrial and economic development of the Rybnik Coal Mining Region led to a substantially increased demand for water, coinciding with a drop in the supply. Consequently it became necessary to prepare a program for water economy measures including:

- closed-water circuits in coal preparation plants
- separation of underground water suitable for drinking and industrial purposes
- treatment of bath-house waste-water to enable reuse.

These measures also promote environmental protection by reducing the quantity of pollutants carried off.

Designs were also developed and implemented for methane delivery pipelines (industrial) linking the methane drainage stations with the present and future users.

Achievements already made in the complex development of the Rybnik Coal Mining Region can serve as a useful example of the implementation of long-term, economic-social planning. Project designs prepared in the late fifties and early sixties provided satisfactory solutions to these problems and determined guidelines for the investment development of the whole region, integrated with the master plan for development of the whole Upper Silesian Industrial Region.

Figures 6.3 to 6.8 show views of some of the mines constructed in the Rybnik Coal Mining Region.

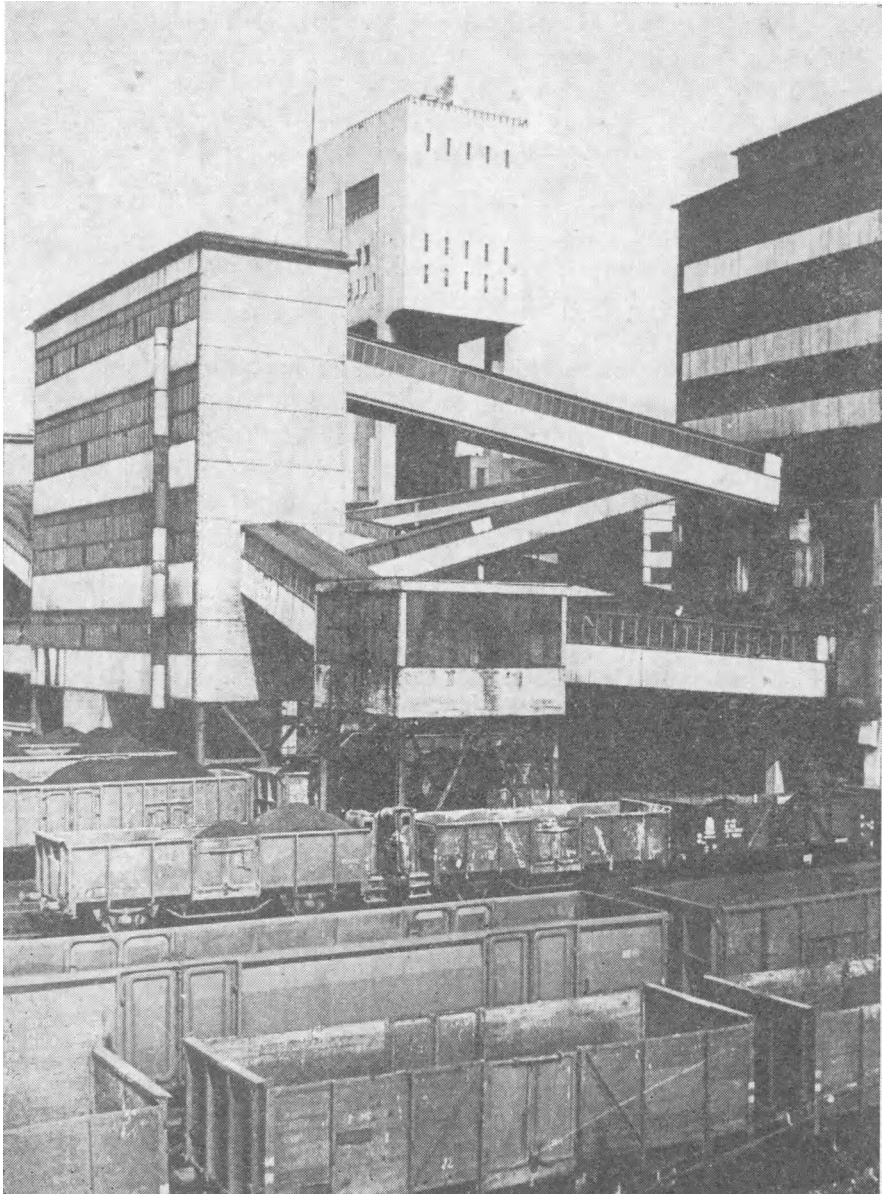

Fig. 6.3 "Moszczenica" mine. Production capacity 12 000 t/day. First workings—1957. Commissioned—1963.



Fig. 6.4 Assembly hall of "Moszczenica" mine.

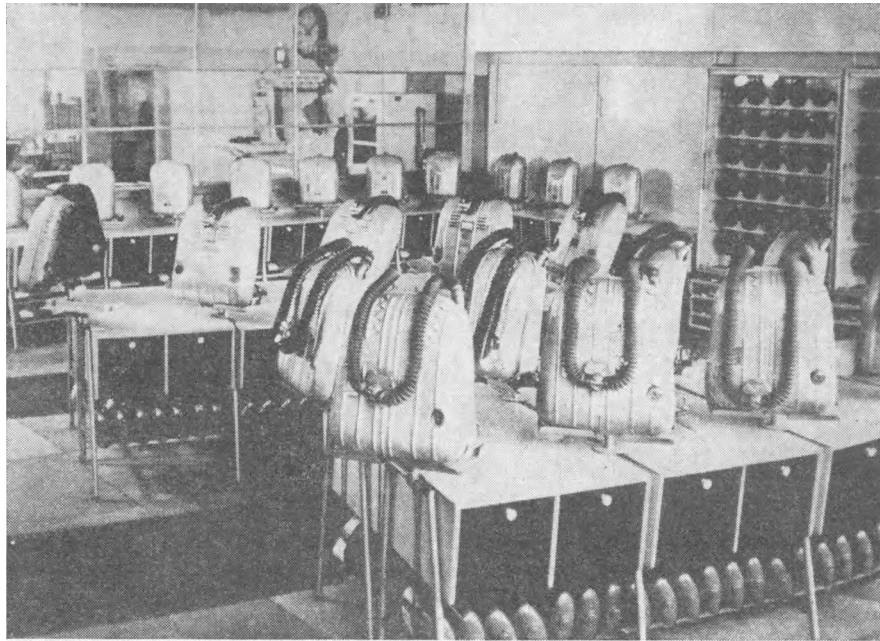

Fig. 6.5 "Moszczenica" mine rescue station.

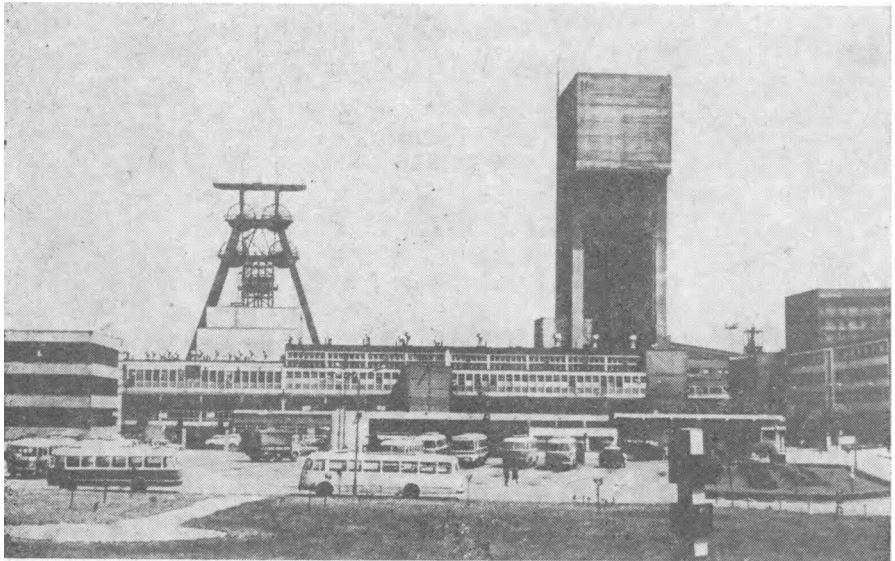

Fig. 6.6 View of "Manifest Lipcowy" mine. Production capacity 12 000 t/day. Construction started—1961. First production—1969. Social-administrative building in the foreground. On the right—coal preparation plant.

### 6.3.3 *Development of the Central Mining Region in the Lublin Coal Basin*

Another example of a complex development is the Lublin Coal Basin (area about 4600 km<sup>2</sup>) situated near the Polish eastern frontier. It has an elongated shape, stretching from south-east to north-west, 180 km in length and 18–37 km in width. The land is virtually flat, consisting chiefly of cultivated fields, meadows and grazing lands. The part where the coal deposit is situated is little industrialized or urbanized and has a sparse communications system. The hard-coal deposit forms an extensive trough with strata dipping at 2–15°. The northern wing dips to the south-west at 2–5°, the southern wing to the north-east at 5–15°. The aggregate thickness of the overburden varies between 400 and 800 m, while the coal seams are 0.8–3.6 m thick. Coal is of steam, flame and gas-flame type with mean calorific value 27.2 MJ/kg (6500 Kcal/kg) in an air-dry state.

In the Lublin Coal Basin an area of about 1 000 km<sup>2</sup>, called Lublin Coal Mining Region, has been delineated. This is divided into three regions, according to the deposit and general geological evaluation (Fig. 6.9):

- The Central Coal Region of area 290 km<sup>2</sup> and recoverable reserves 4 000 million tonnes



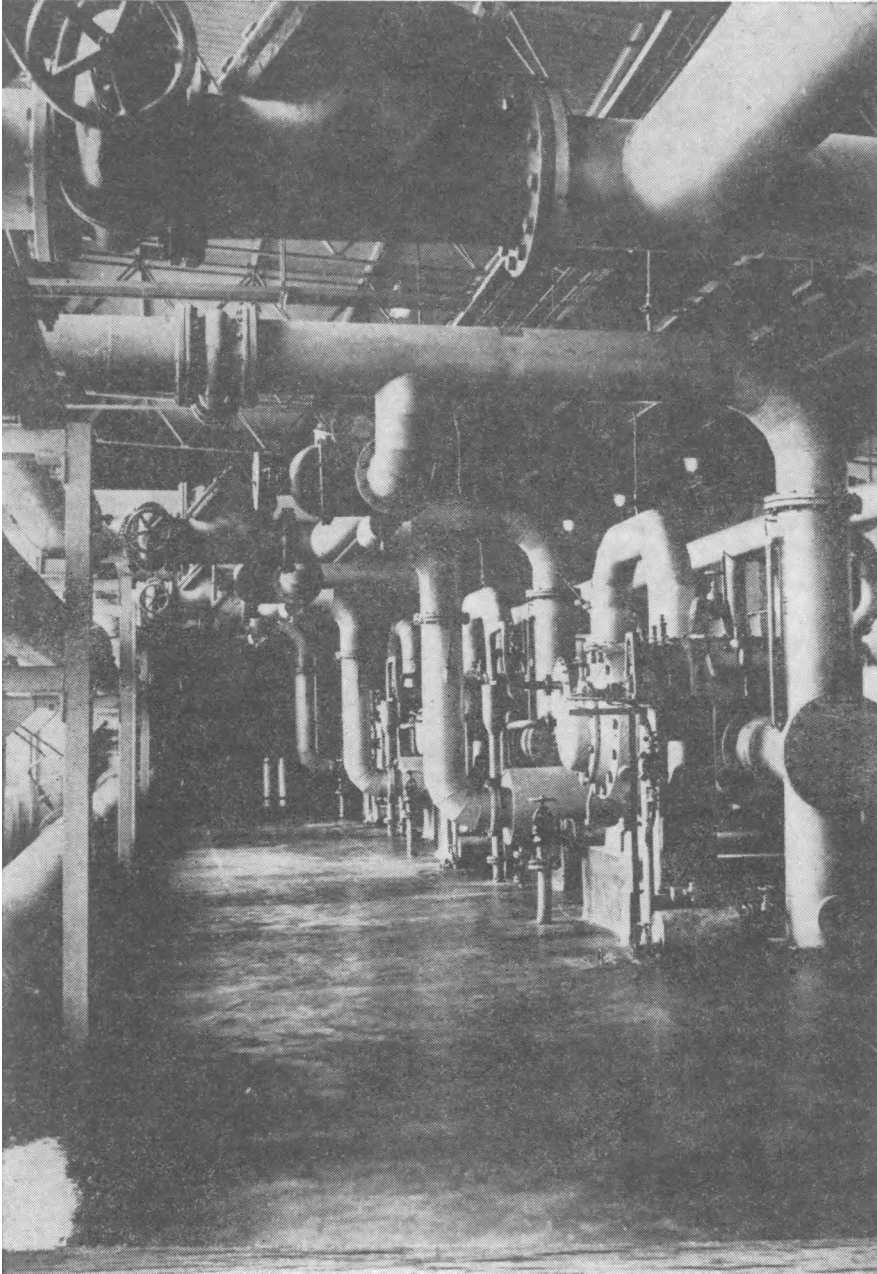

Fig. 6.7 Part of methane drainage station in one of the gassy mines of the Rybnik Mining Region. Gas compressors of capacity  $44 \text{ m}^3/\text{min}$  each.

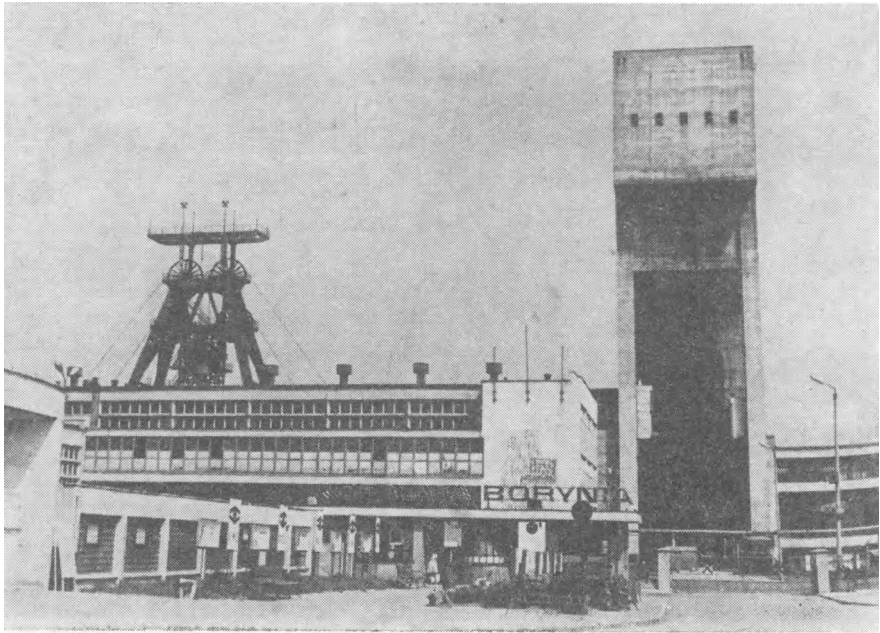

Fig. 6.8 "Borynia" mine. Production capacity 10 000 t/day. Construction started—1969. First production 1971.

- The Northern Coal Region of area 430 km<sup>2</sup> and recoverable reserves 10 000 million tonnes
- The Southern Coal Region of area 250 km<sup>2</sup> and recoverable reserves 6 000 million tonnes.

The Central Mining Region was chosen as the most promising for an initial development in view of the most accurate knowledge of its geological structure, suitable level of coal reserves, comparatively easy linking up with the existing infrastructure and the possible development of the regions to the north and south.

The plan for complex, centralized development envisaged the Central Region as an integrated production-economic unit with a central coal preparation and dispatch plant and centralized industrial, social and management facilities. The basic module for deposit development was taken to be a sub-unit of 6 000 tonnes per day production capacity and concession area about 10 km<sup>2</sup>. Two sub-units form a production unit (mine) of capacity 12 000 tonnes per day with four shafts, two for materials/manriding, one upcast ventilation shaft and one production shaft which also serves as a ventilation

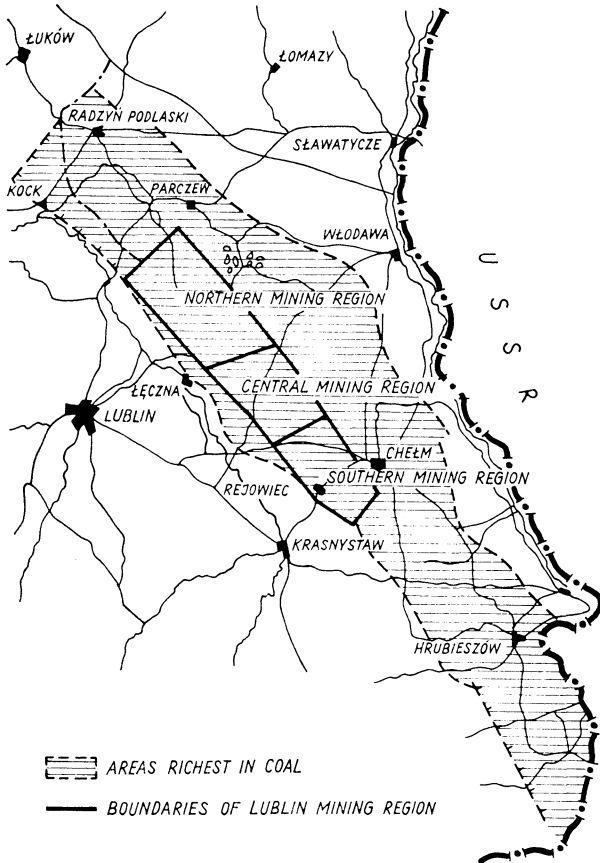

Fig. 6.9 Lublin Coal Basin and Lublin Coal Mining Region.

downcast shaft. Seven such production units are foreseen in the Central Mining Region (Fig. 6.10).

The total output was to be transported by belt conveyors to a joint mining industrial district with the central coal preparation plant and other centralized facilities (workshops, stores, transport) serving all the mines of the region. Figure 6.11 gives a diagram of an in-seam extraction model for a production unit. Seams will be mined in a longwall system with caving, longwalls of length 150–200 m and life 1 500–2 000 m with daily production from one longwall 1 000–2 500 tonnes.

The scheduled division of the region into production units with centralized auxiliary services (coal preparation workshops, stores, transport facilities, etc.) and the most up-to-date technical and organizational methods was planned.

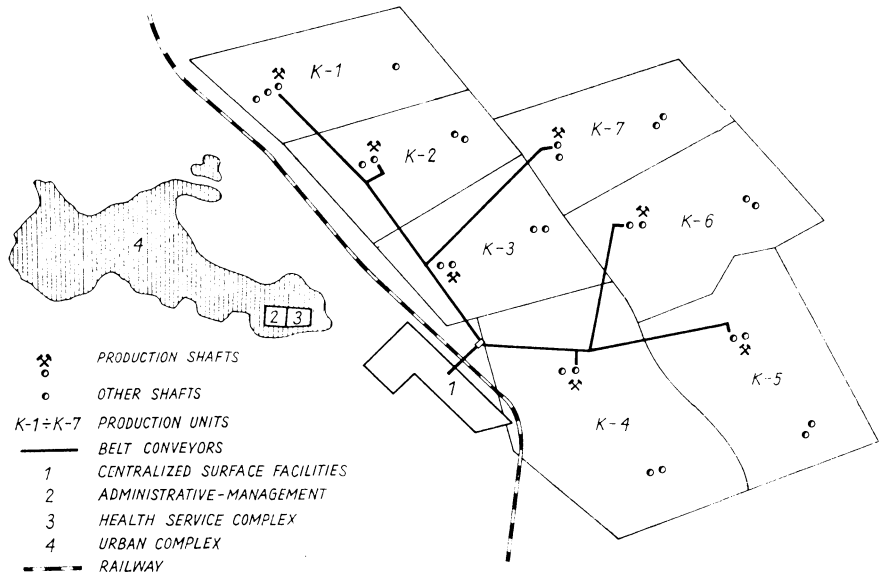

Fig. 6.10 Planned development of the Central Mining Region in Lublin Mining Basin.

This should give an appreciable reduction in the cubic capacity of surface facilities and in the number and length of workings driven in the rock, and hence shortening of the construction cycle and economies in investment expenditure. Table 6.3 gives a comparison of the cubic capacity of surface buildings and of stone workings in the Lublin Central Mining Region and figures for the “Manifest Lipcowy” mine in the Rybnik Coal Mining Region, having the same production capacity of 12 000 tonnes per day. These figures highlight the effects of improvements in the design.

Decisions on the surface layout at the mines of the Central Mining Region were governed by the following factors:

- introduction of centralized coal preparation and dispatch, central workshops, stores, transport and social services
- observing the principle of centralized urban development (with high standard of housing and service facilities for the mine personnel and their families) located as close as possible to the green protection zones between the town and the industrial part of the region.

Social and management facilities, schools and medical services were to be sited in the newly constructed mining town with an initial population (estimated on the basis of the number of people employed in mining, civil engineering, the food industry, services) of over 100 000 inhabitants.

The mineralized underground water was to be carried off to a large-capacity

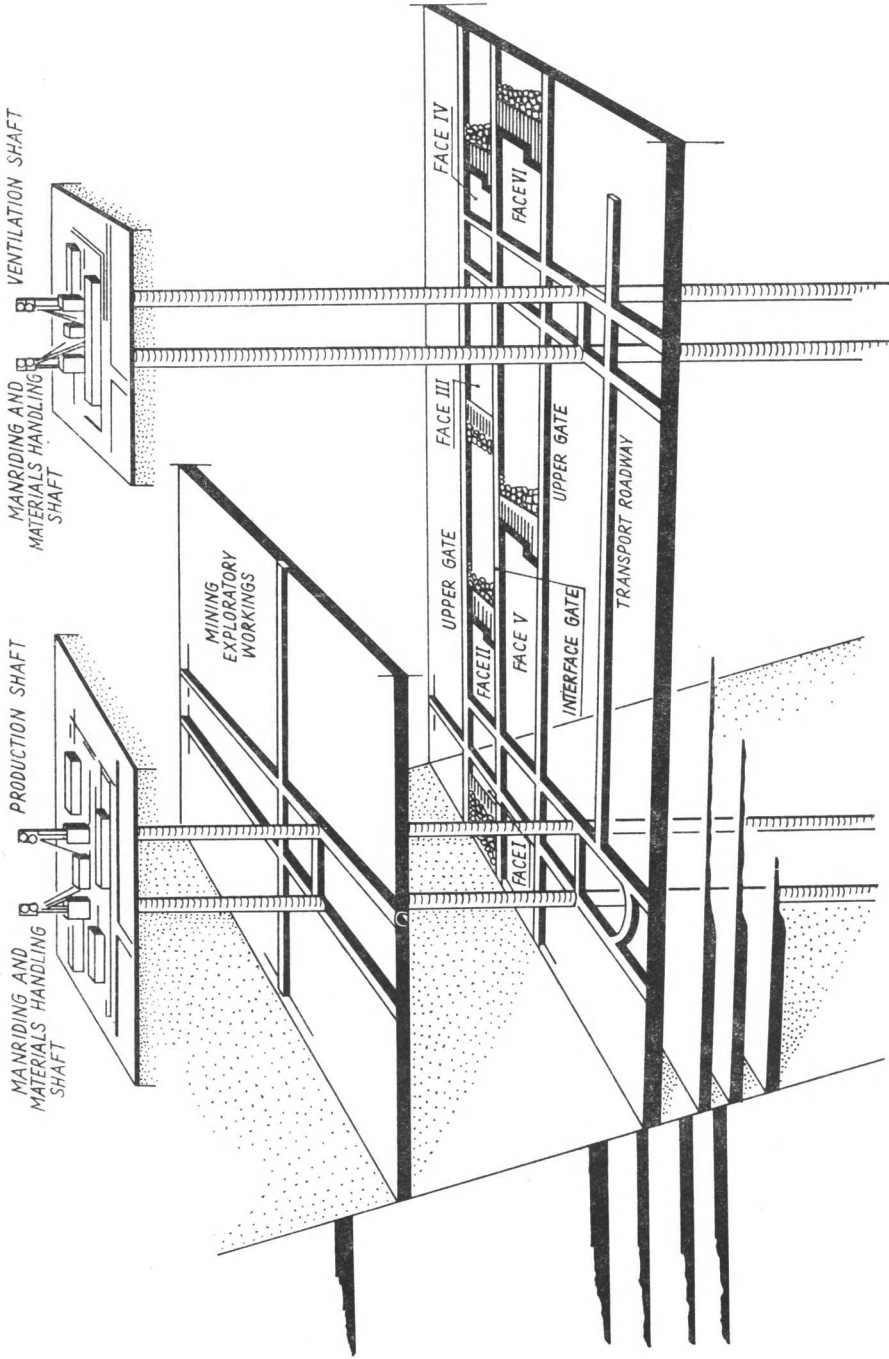

Fig. 6.11 Schematic diagram for a production unit of 12 000 t/day capacity.

TABLE 6.3 Comparison of cubic capacity of surface facilities and of stone workings at the "Manifest Lipcowy" mine in the Rybnik Coal Mining Region and a production unit in the Central Mining Region in the Lublin Coal Basin

Item	Units	"Manifest Lipcowy" mine	Production unit in the Lublin Central Mining Region
Production	t/day	12 000	12 000
Surface facilities including		500 000	64 000
— production facilities	m <sup>3</sup>	336 000	38 000
— safety of work and health facilities	m <sup>3</sup>	70 000	17 000
— auxiliary facilities	m <sup>3</sup>	94 000	9 000
Area of surface development	ha	40	10
Chamber workings underground	m <sup>3</sup>	15 000	1 500
Cross-cuts	m	34 000	300

settling pond from which it would be fed to the rivers during high water-level periods (hydrotechnical dilution). Communal effluent from both the industrial and urban zones was to be treated at a joint treatment plant. The design of the central coal-preparation plant envisages storage reservoirs to prevent accidental drainage of washery waters to natural watercourses.

Heat for the town and centralized facilities and plants in the industrial zone was scheduled to be supplied from a single heat-and-power generating station.

Maximum utilization of waste from the preparation plant and protection of surface water, shallow-lying water horizons and beauty spots for the whole mining region was planned.

Full development of the Lublin Central Mining Region was not possible in view of the economic difficulties in Poland in the late seventies and early eighties. The program had to be reassessed and updated while centralized development of the region was abandoned.

Implementation of this complex plan would require that the time of execution of individual elements of the design should be coordinated within the detailed investment program and the overall construction time-table. Centralized investment may be implemented in stages, but these must always be in advance of the main investment for which they fulfil a services or supplementary technological function. Hence centralized development demands larger investment expenditure in the initial phase than is necessary for a non-centralized system, implemented in stages over a longer period. This does not invali-

date the general principle that total investment outlay and production costs are less for centralized than for non-centralized development.

For various reasons the plan for centralized development of this mining region was set aside. The mines will be constructed in stages as independent production and organizational units with their own coal preparation plants, workshops, stores, social and services facilities. By the end of 1982 the first stage of the construction of the K-1 mine was completed, that is the first production unit in the Central Mining Region (Fig. 6.10). At present (1984) work on this mine continues, while construction of the second (K-2) mine has been started and the third (K-3) is in the design stage. However, the general principle will be maintained, i.e. complex development of the region, introduced in stages depending on the available investment resources.

As already mentioned, the K-1 mine, sited in Bogdanka in the Central Mining Region of Lublin Coal Basin, has been completed. Figure 6.12 shows part of this mine as it was in December 1982, i.e. when the mine was opened for extraction. Figure 6.13 shows the scheduled duties of shafts, advances achieved in shaft sinking and also winding installations at the end of stage one, and the final (second) stage. The following points are noteworthy:

- imprecise definition of duty of shaft I
- utilization, in the transition stage, of shaft II (materials handling and manriding) for production purposes (until sinking of shaft III and erection of skip winding installation in stage two)
- planned future use of shaft S IV, built in the vicinity of mine K-2, as one of the upcast shafts.

The present model of the mine (as shown on Fig. 6.13) shows the discrepancies discovered during shaft sinking, especially the sinking of shaft I. The original schedule was:

- shaft I, production, skip winding, upcast
- shaft II, materials-manriding and production (skip-cages), downcast
- shaft III, materials-manriding (cages), downcast
- shaft IV, upcast.

Shaft I was sunk using the ground freezing method. After four months of freezing the system was taken to a greater depth (710 m). Control measurements during the freezing process indicated a correct design thickness of the frozen strata (up to 5.5 m) and correct mean design temperature ( $-15^{\circ}\text{C}$ ). Central drilling carried out at the shaft bottom showed that the loose, watery formations of Albian in the shaft core remained unfrozen but their freezing was essential for further shaft sinking. Continued intensive freezing resulted in damage to the shaft lining between 200–400 m due to volumetric expansion of the Cretaceous at sub-zero temperatures. Hydrogeological tests carried

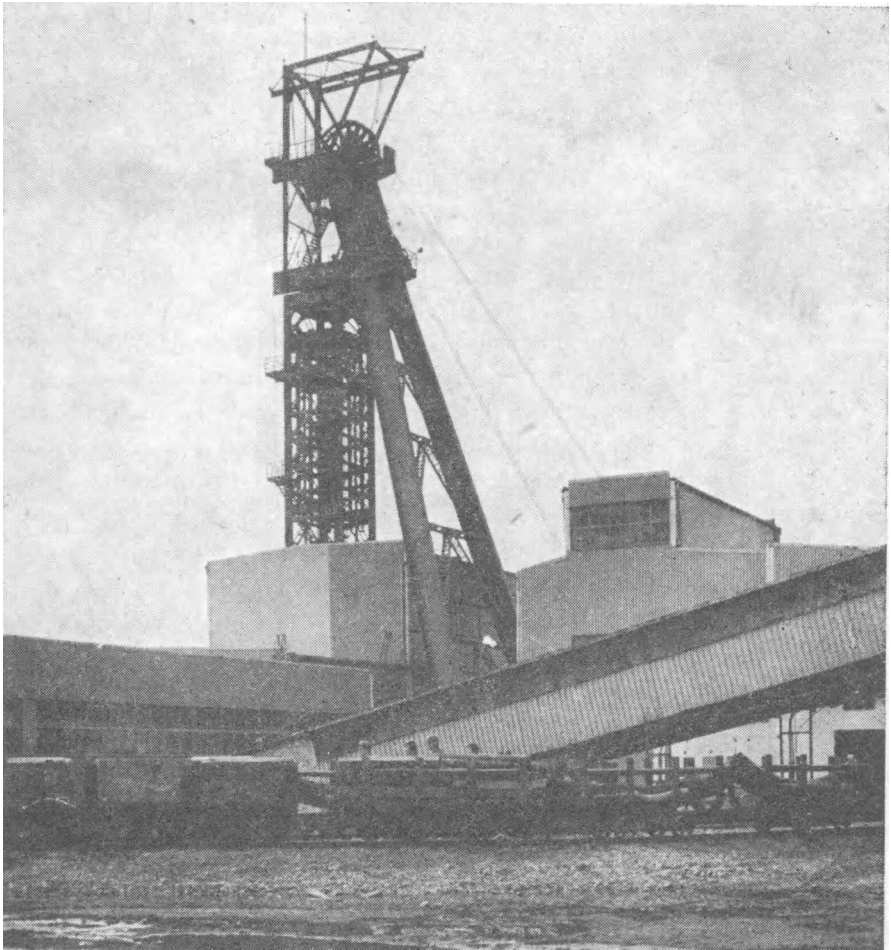

Fig. 6.12 View of K-1 hard-coal mine in Bogdanka, the first mine in Lublin Mining Basin. (Photo: shaft II including pit top buildings and belt conveyor bridge).

out before shaft sinking had not indicated watering of the Cretaceous at this depth. It was decided to construct additional concrete lining in shaft I to give reinforcement between 170–430 m, at the cost of reducing shaft inside diameter by 1 m. After freezing the shaft I core, sinking was continued to the final depth of 995 m. Experience gained was utilized when sinking shaft II, delayed for six months, and also shaft III (all three shafts sited on the main mine surface sector). After completing the sinking of shafts I and II work was begun to excavate shaft-bottom workings at level 960 m, up to



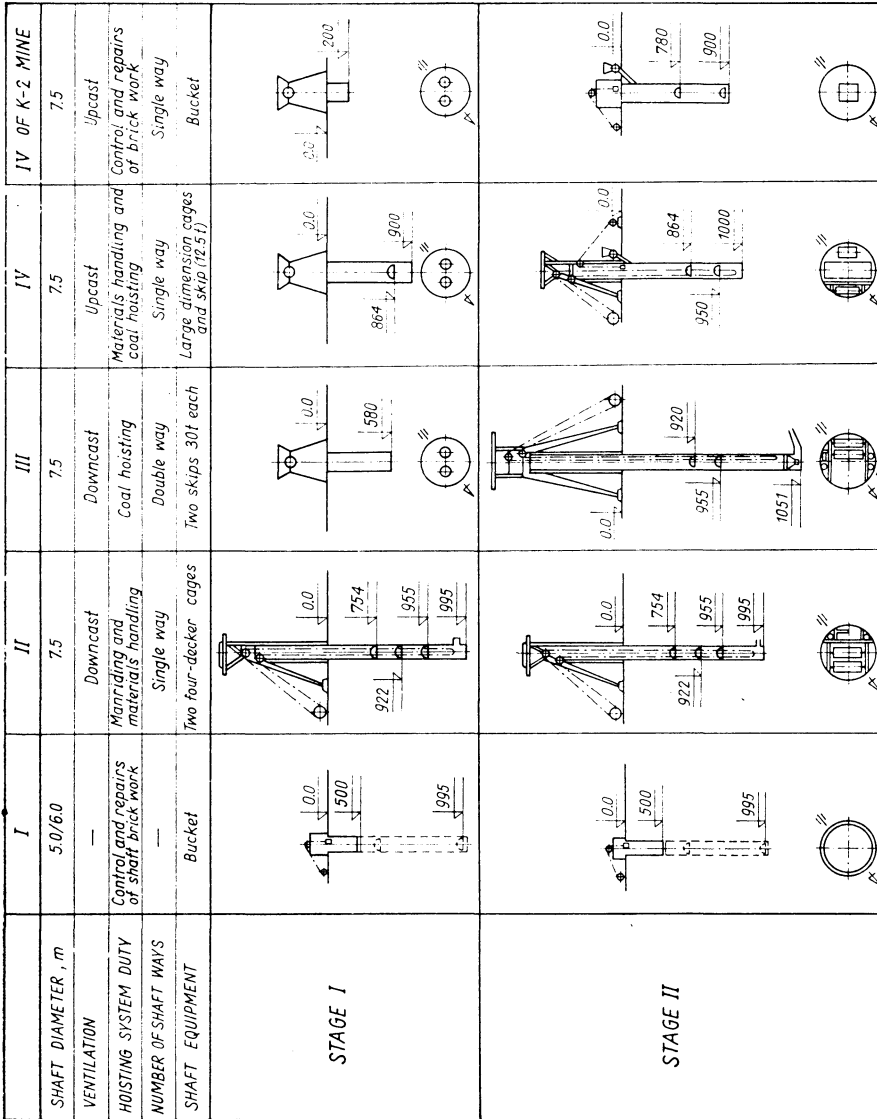

Fig. 6.13 Shaft duties, progress in shaft sinking, hoisting facilities at the end of stage I of construction of K-1 mine in Bogdanka (December 1982). Stage II illustrates final duties of facilities.

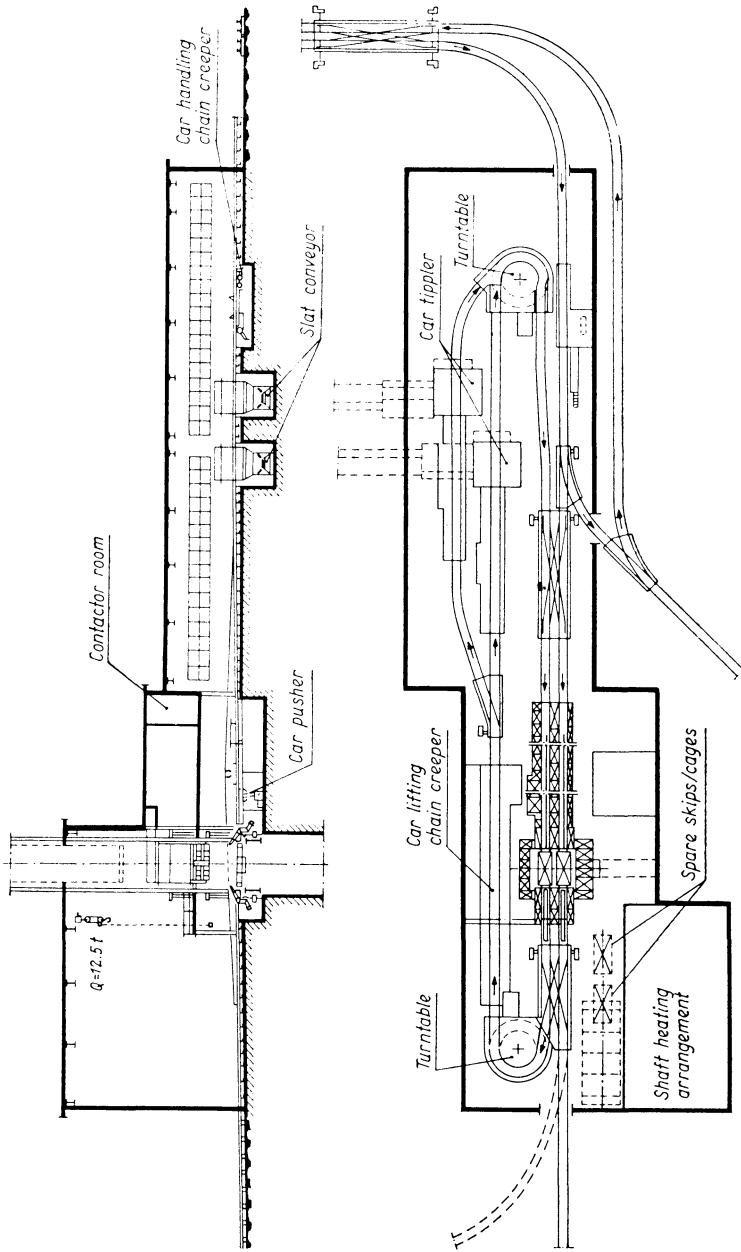

Fig. 6.14 Pit top of the No. II shaft (multi-duty) at the K-1 mine in Bogdanka.

October 1979 a joint length of 430 m was driven. At that point a large quantity of loose material penetrated into shaft I at depth 635 m, silting up the shaft and a part of the shaft bottom workings. It then became necessary to construct isolating dams for shaft II from shaft I at levels 754 and 960 m to block shaft I at depth 500 m with an isolating stopper and to develop a new model of the mine as illustrated on Fig. 6.13.

Particularly noteworthy is the layout of the pit top at shaft II including the car circuit at the shaft eye (Fig. 6.14). At the higher part of the pit top (on the car pushing side) is located the technological equipment for the car circuit and for skip/cage changeover, while the installation for heating the downcast air is located in the annexe. In the lower part of the pit-top buildings are the rail tracks and two tipplers, one for cars with coal and one for cars with rock. Under the tipplers are slat conveyors which deliver the gotten to the belt conveyors. The built-up mine surface sector area is 1 740 m<sup>2</sup>, the utilized area is 2 000 m<sup>2</sup> and the cubic capacity 18 400 m<sup>3</sup>.

## **Chapter 7**

### **Planning and Design of Hard-Coal Preparation Plants**

#### **7.1 Design Stages**

Increasingly stringent quality requirements from hard-coal consumers plus the rising content of impurities in the gotten due to the greater mechanization of extraction means that the question of coal preparation is increasingly important. In all mining countries the post-war period saw significant development in technologies and range of hard-coal preparation, especially for coking coal. Many innovations have been made in the technological/machinery layouts and in the construction of the preparation plants.

The design stages when constructing, reconstructing, modernizing or extending coal preparation plants are the same as described in Section 5.2. In Section 5.2 the scope of the basic design principles was outlined and in point 4 the technical specification for the investment undertaking is given (in tabular form supplemented by descriptions) including production program and technology. For investment projects involving the construction of new coal preparation plants the technical specification should include:

- characteristic parameters of the mineral to be processed
- planned development of plant production capacity (stages)
- technological flowsheet including design of the water-slurry circulation
- characteristic parameters of the final product
- spatial layout of the plant including delivery of raw material and loading of the ready product to rail cars or other means of transport
- electric energy, transport, workshop and storage facilities
- work safety and health measures.

Modernization or extension of an existing preparation plant has to conform to the same design principles as a new plant but it must be adapted to existing conditions.

In the detailed design stage plans must be prepared for the individual machines/technological systems and the various preparation plant facilities. All the requirements specified in Section 5.2.3 must be complied with.

## 7.2 Classification of Preparation Plants

The basic duty of a coal preparation plant is to separate useful products (coal and middlings) from waste (rock, metal, wood and other impurities) by the use of various concentration methods, e.g. separation, dewatering, crushing and drying to obtain a product of quality parameters as required by the consumer. The operations must be closely coordinated, both technologically and economically, with those of the coal mine. From the aspect of number of mines served, two types of preparation plants may be distinguished:

- individual plants, processing coal from one mine only
- central plants, processing coal from several mines.

Usually each mine has its own (individual) preparation plant forming an integral part of the mine. Central preparation plants are located in mining regions where the production from individual mines and the distances between them are small.

Considering type of coal dealt with, we may distinguish coking-coal and steam-coal preparation plants, differing widely in the technological/machines systems and in the costs of construction and operation.

The range of concentration envisaged varies from country to country, and in general depends on the type of coal processed. Preparation plants are usually (e.g. in Poland) planned for following ranges:

- to 20/10 mm (steam coal)
- to 0.5 mm (steam coal)
- to 0 mm (coking coal, more rarely steam coal).

Coal preparation plants consist of technological systems, these can be divided into technological sections, and finally technological operations. A technological system contains a complete set of technological sections which provide handling and processing of the coal gotten (feed) and delivery of the final products to rail cars or other means of transport. A technological section is a set of technological operations designed to achieve a specific technological purpose. The types of basic technological sections in modern preparation plants with coal concentration to 20(10), 0.5 and 0 mm are illustrated in Table 7.1 while Table 7.2 gives the types of operations taking place in these sections.

The number of technological sections in a coal preparation plant varies

TABLE 7.1 Basic technological sections in modern coal preparation plants with ranges of concentration to 20/10, 0.5 and 0 mm

Types of technological sections	Technological sections of concentration ranges			Technological sections variants
	to 20/10 mm	to 0.5 mm	to 0 mm	
Preparation of charge	*	*	*	<ol style="list-style-type: none"> <li>1. Preparation of charge with non-selective crushing of coarse fractions</li> <li>2. Preparation of charge with selective crushing of coarse fractions</li> <li>3. Preparation of charge with preliminary concentration of coarse fractions in classifiers</li> </ol>
Concentration of coarse and medium coal	*	*	*	<ol style="list-style-type: none"> <li>1. Coal concentration in classifiers</li> <li>2. Coal concentration in jigs</li> </ol>
Concentration of small coal	*	*	*	<ol style="list-style-type: none"> <li>1. Coal concentration in jigs</li> <li>2. Coal concentration in cyclones</li> </ol>
Secondary concentration of intermediate product	—	—	*	<ol style="list-style-type: none"> <li>1. Coal concentration in jigs</li> <li>2. Coal concentration in cyclones</li> </ol>
Water-slurry circulation	*	*	*	<ol style="list-style-type: none"> <li>1. Without slurry flotation</li> <li>2. With slurry flotation</li> </ol>
Drying of concentrate	—	—	*	<ol style="list-style-type: none"> <li>1. Drying of concentrate class 0.5–0 mm</li> <li>2. Drying of concentrate class 10–0 mm</li> </ol>
Loading of final products	*	*	*	—

TABLE 7.2 Basic technological operations in the technological sections

Types of technological sections	Types of technological operations
Preparation of charge	<ol style="list-style-type: none"> <li>1. Pre-preliminary classification</li> <li>2. Non-selective crushing, selective crushing or preliminary concentration in classifiers</li> <li>3. Quantity and quality stabilization in bunkers</li> <li>4. Preliminary classification</li> </ol>
Concentration of coarse and medium coal	<ol style="list-style-type: none"> <li>1. Charge concentration</li> <li>2. Dewatering of products</li> <li>3. Final classification or crushing of concentrate</li> </ol>
Concentration of small coal	<ol style="list-style-type: none"> <li>1. Desliming of charge</li> <li>2. Charge concentration</li> <li>3. Dewatering of products</li> </ol>
Secondary concentration of intermediate product	<ol style="list-style-type: none"> <li>1. Desliming of charge</li> <li>2. Charge concentration</li> <li>3. Dewatering of products</li> </ol>
Water-slurry circulation	<ol style="list-style-type: none"> <li>1. Control classification of washery waste waters</li> <li>2. Clarification of washery waters</li> <li>3. Flotation or non-flotation of slurry</li> <li>4. Clarification of flotation waters</li> <li>5. Dewatering of products</li> </ol>
Drying of concentrate	<ol style="list-style-type: none"> <li>1. Quantity stabilization of charge</li> <li>2. Drying of concentrate</li> </ol>
Loading of final products	<ol style="list-style-type: none"> <li>1. Storage of products</li> <li>2. Weighing and loading of product</li> </ol>

from 4-7 and depends on the type of coal (coking or steam coal), range of preparation and whether secondary preparation of the intermediate product and drying of the concentrate is used. Secondary preparation of the intermediate product is used for coking coal but seldom for steam-coal preparation plants. The decision to apply secondary preparation depends on the quantity of middlings in the raw coal, the densimetric characteristics of middlings

crushed to below 10 mm and on the type of machinery used for primary preparation (efficiency of the process). Drying of the concentrate is used mainly to comply with consumers' requirements but cost of transport and climatic conditions are also taken into account.

### 7.3 Initial Data for Design of Preparation Plants. Criteria for Choice of Sections and Technological Operations

In Section 7.1 general information was given on the stages in the design of preparation plants. To plan a technological process the following initial data must be known:

- mine net and gross production per day and per year
- working time expressed as number of working days per year and hours per working day
- type of raw coal (coking or steam coal)
- content of ash, hygroscopic and transient moisture, organic and pyrite sulphur in the raw coal
- calorific value of dry, ash-free coal
- selective crushing suitability of raw coal coarse grades
- grain size of the raw coal
- densimetric composition of the raw coal
- densimetric composition of crushed middlings
- washing-out characteristics of the barren rock
- slurry sedimentation properties
- slurry flotability characteristics
- slurry filtration properties
- customers' requirements as to grain size, ash content, moisture content, sulphur content and calorific value
- environmental protection requirements.

The following initial data is also required for planning constructional, electrical and installations projects:

- 1:5000 scale map with proposed plant siting
- 1:1000 scale topographical plan
- soil characteristics and ground conditions
- conditions for supply of electric power, industrial and drinking water.

The production capacity of a coal preparation plant is calculated from the formula

$$Q_z = \frac{W_R^N \cdot 100 \cdot 1.2}{(100 - K) T_1 T_2} = \frac{W_R^B \cdot 1.2}{T_1 T_2} \quad (7.1)$$



or

$$Q_z = \frac{W_D^N 100 \cdot 1.2}{(100 - K) T_2} = \frac{W_D^B \cdot 1.2}{T_2}, \quad (7.2)$$

where:

$Q_z$ —preparation plant output, t/h

$W_R^N$ —net mine production, t/year

$W_R^B$ —gross mine production, t/year

$W_D^N$ —net mine production, t/day

$W_D^B$ —gross mine production, t/day

$K$ —average quantity of waste produced in the plant, %

$T_1$ —plant working time, days/year

$T_2$ —effective plant working time, h/day (usually  $T_2 = 13$  h/day with two-shift working and 20 h/day with three-shift working)

$T_3$ —available plant working time, h/day (usually  $T_3 = 16$  h/day with two-shift working and 24 h/day with three shift working)

1.2—plant production capacity reserve factor  $\frac{T_3}{T_2}$ .

The average quantity of waste  $K$  produced by the plant is calculated from the formula

$$K = \frac{Q_{s_1} K_1 + Q_{s_2} K_2 + \dots + Q_{s_n} K_n}{Q_{s_1} + Q_{s_2} + \dots + Q_{s_n}}, \quad (7.3)$$

where:

$Q_{s_1}, Q_{s_2}, \dots, Q_{s_n}$  — output from the technological sections, t/h

$K_1, K_2, \dots, K_n$  — quantity of waste produced in the technological sections.

The production capacity of a technological section is determined from the equation

$$Q_s = \frac{Q_z U}{100}, \quad (7.4)$$

where  $U$  is the quantity of feed delivered to a technological section expressed as a percentage of total feed to the preparation plant.

Coking coal is concentrated in the range to 0 mm, steam coal to 10, 0.5 or 0 mm. The decision to concentrate steam coal 10–0.5 mm and 0.5–0 mm classes depends on ash content and content of organic and pyrite sulphur in the raw coal.

The maximum grain dimensions in the preparation process feed depends on:

— type of coal (coking or steam)

— raw-coal grain size consist especially when considering yield of coarse-coal fractions

- densimetric composition of the raw coal particularly the quantity of middlings
- required grain size consist of saleable coal
- type of machines for concentration of coarse fractions (separators or jigs).

In steam-coal preparation plants the maximum feed grain size is usually 200 or 150 mm, while in coking-coal plants it is 100, 50 or 30 mm.

Factors governing the choice of selective or non-selective crushing of coarse classes of raw coal are the required yield of coarse fractions, stone content in the coarse fractions and the differences between hardness of coal and stone. The general technological criteria favouring choice of selective crushing of coarse raw-coal classes are large quantity of stone in the coarse fractions and good crushing properties of the coarse coal, i.e. a minimum stone separation efficiency of 50% with coal losses (fraction below 1.8 t/m<sup>3</sup>) in the separated stone not more than 1%.

Yield of various grain classes from the coal concentrated in the particular sections of the preparation plant depends on maximum grain dimensions of the feed, grain size consist of the raw coal, concentration capacity of the various grain sizes in the raw coal and type of machines used for processing.

The type of machines used in preparation plant sections dealing with coarse and medium coal (separators or jigs) and fines (cyclones or jigs) depends mainly on coal concentration capacity  $S$  (%) calculated from the formula

$$S = \frac{100 \gamma_1}{100 - \gamma_2} = \frac{100 \gamma_1}{\gamma_3}, \quad (7.5)$$

where:

$\gamma_1$ —percentage yield of fractions 1.5–1.8 t/m<sup>3</sup>

$\gamma_2$ —percentage yield of fractions above 1.8 t/m<sup>3</sup>

$\gamma_3$ —percentage yield of fractions below 1.8 t/m<sup>3</sup>

Coal concentration capacity is assessed as follows:

$S < 4\%$  —easy concentrating coal

$S = 4-10\%$  —medium concentrating coal

$S = 10-17\%$ —difficult concentrating coal

$S > 17\%$  —very difficult concentrating coal.

For the treatment of coal of easy or medium concentration capacity jigs are recommended, while for difficult or very difficult concentrating coal heavy medium separators or cyclones are used.

Coking coal is generally subjected to three-product processing, yielding concentrate, intermediate product and waste, while for steam coal two-product processing giving concentrate and waste is used.

The quantity of barren rock and its washing-out capacity decide the order

of separation of products in three-product concentration of coal in heavy-medium classifiers and cyclones.

With large quantity of barren rock and easy washing-out capacity, classification in primary separators and cyclones (first stage of concentration) is used. With difficult washing-out capacity and small quantity of barren rock, waste products are separated in classifiers and secondary cyclones (second stage of concentration). The densimetric composition of the crushed middlings determines whether or not secondary concentration is required, and if so what method should be used. Slurry flotation capacity, determined by the quality of products yielded, governs the choice of two-product or three-product slurry flotation. The required flotation time determines the design capacity of flotation machines. The capacity of a flotation machine as a function of slurry flotation time is given by the formula

$$V_F = VT^{-1}, \quad (7.6)$$

where:

$V_F$  — flotation machine throughput,  $m^3/h$

$V$  — flotation machine capacity,  $m^3$

$T$  — flotation time, h.

The longer the required slurry-flotation time, the smaller the flotation-machine throughput for given machine capacity.

The sedimentation properties of the slurry, expressed as the sedimentation rate, determine the area of Dorr thickeners used to clarify washery and flotation water. The approximate unit feed load of a Dorr thickener as a function of slurry sedimentation rate is

$$V_D^z = 0.65V_s, \quad (7.7)$$

where:

$V_D^z$  — unit load of the Dorr thickener,  $m^3/h \cdot m^2$

$V_s$  — slurry sedimentation rate, m/h.

The greater the slurry sedimentation rate, the longer may be the unit loading of the Dorr thickeners, and hence the smaller their diameter or number.

The filtration properties of raw 0.5–0 mm slurry (expressed by the *Dahlstrom filtration index*) determine the type of dewatering machines required (vacuum filters, sedimentation centrifuges or filter presses). The Dahlstrom filtration index  $D$  for 0.5–0 mm slurry is given by:

$$D = A\sqrt{\gamma}, \quad (7.8)$$

where:

$A$ —ash content in 0.075–0 mm class for analytically pure state, %

$\gamma$ —yield of class 0.075–0 mm for analytically pure state, %.

The scale of evaluation of filtration properties of 0.5–0 mm slurry is:

$D < 100$  —easy filtering

$D = 100\text{--}200$ —medium filtering

$D = 200\text{--}300$ —difficult filtering

$D > 300$  —very difficult filtering.

To filter easy and medium filtering slurry vacuum filters are used; for difficult and very difficult filtering slurry sedimentation centrifuges and filter presses are used.

The filtration properties of the raw 0.5–0 mm slurry also govern whether or not to use desilting of the water-slurry circulation.

#### 7.4 Principles for Design of Preparation Plants

Standardized units and assemblies should be used where possible to shorten both design and construction time of the plant. For instance, in Poland four standardized technological flowsheets have been prepared based on typical production for 500 t/h and 1000 t/h. Standard production throughputs of the plants are  $2 \times 500 \text{ t/h} = 1000 \text{ t/h}$  and  $2 \times 1000 \text{ t/h} = 2000 \text{ t/h}$ . Standardized technological flowsheets and capacities facilitate rational development of designs for machinery and equipment, automation schemes for the technological processes and improvement of technical and economic indices.

The planning of a flowsheet in a modern preparation plant is based on:

- large throughput (up to 1000 t/h) with as many as possible of the basic operations carried out in single machines, the number of machines for additional operations being kept to a minimum
- number of sections and of technological operations kept to a minimum
- maximizing concentrate yield and minimizing coal losses in the waste due to the use of high efficiency preparation machines such as classifiers, jigs, cyclones and flotation machines
- minimizing number of types and sizes of machines and equipment to facilitate maintenance and repairs (also making it feasible for machinery manufacturers to increase concentration of production)
- using closed water-slurry circulation (use of Dorr thickeners, vacuum filters, centrifuges, filter presses)
- preparation of waste for further processing
- minimum consumption of electric power
- maximum automation of technological operations to reduce the manpower demand
- protection of the environment (vibration, noise, dust)

- minimizing investment expenditure
- minimizing costs of production.

The effectiveness of coal preparation in the individual grain classes, using machines as recommended in the technological flowsheets, may be expressed approximately by the imperfections indices as follows:

- classifiers (200–10 mm) —0.05
- cyclones (30–0.5 mm) —0.08
- jigs (10–0.5 mm) —0.15
- flotation machines (0.5–0 mm) —0.30.

The preparation effectiveness expressed in losses of coal and middlings in the waste is approximately:

- classifiers (200–10 mm) —2%
- cyclones (30–0.5 mm) —3%
- jigs (10–0.5 mm) —6%
- flotation machines (0.5–0 mm) —9%.

When planning the spatial layout of machinery and equipment in individual sections of a preparation plant the following rules should be observed:

- maximum use of gravity transport
- minimum length of transport routes
- ensuring easy assembly, maintenance and dismantling of machines and equipment
- flexible linking of the individual systems in the plants
- possibility of stage-by-stage construction of the systems and of future expansion of the plant.

Division of the plant into building units depends on the production capacity and the number and type of technological sections. Older designs usually included a large number of individual facilities, modern ones use a limited number of such units. Steam-coal preparation plants, concentrating the coal to 10 mm, currently have most often (e.g. in Poland) seven basic facilities:

- feed preparation station
- reserve standby hoppers for the feed
- complex block providing preliminary classification of the feed, coal-enrichment section, loading of over 10 mm coal class and filtration of the slurry
- radial thickeners
- settling tanks for circulation waters
- dumps for 10–0 mm fines
- loading station for 10–0 mm fines.

Modern coking-coal preparation plants enriching coal to 0 mm usually include (e.g. in Poland):

- feed preparation station

- reserve-standby hoppers for the feed
- complex block where all the coal-enrichment sections are located
- radial thickeners
- settling tanks for circulation water
- drying station for flotation concentrate
- dewatering station for flotation waste
- concentrate storage yards
- concentrate loading station.

### 7.5 Modern Designs for Coal Preparation Plants

Modern coking and steam coal preparation plants are usually based on the technological models illustrated in Table 7.3. The *technological model* means a group of basic technological sections, the following data being specified:

- maximum grain size of raw coal prepared for concentration
- grain classes of coal to be concentrated
- coal concentration system (two-product or three-product)
- basic types of machines in the technological sections.

TABLE 7.3 Modern technological models of coking and steam-coal preparation plants

Model	Type of coal	Concentration range	Sections of charge preparation and concentration		
			Types of sections	Grain class mm	Type of equipment
I	Coking	to 0 mm	1. Preparation of charge	200–10	screens
				10–0	crushers
			2. Three-product concentration	200–10	classifiers
			3. Three-product concentration	10–0.5	jigs
			4. Three-product concentration	10–0.5	cyclones
5. Two-product concentration	0.5–0	flotation machines			
II	Coking	to 0 mm	1. Preparation of charge	100–10	screens
				10–0	crushers
			2. Three-product concentration	100–10	classifiers
			3. Three-product concentration	10–0.5	cyclones
4. Two-product concentration	0.5–0	flotation machines			

TABLE 7.3 *continued*

Model	Type of coal	Concentration range	Sections of charge preparation and concentration		
			Types of sections	Grain class mm	Type of equipment
III	Coking	to 0 mm	1. Preparation of charge	50-0	screens crushers
			2. Three-product concentration	50-0.5	jigs
			3. Three-product concentration	10-0.5	cyclones or jigs
			4. Two-product concentration	0.5-0	flotation machines
IV	Coking	to 0 mm	1. Preparation of charge	30-0	screens classifiers crushers
			2. Three-product concentration	30-0.5	cyclones
			3. Two-product concentration	0.5-0	flotation machines
V	Steam	to 10 mm	1. Preparation of charge	200-10 10-0	screens crushers
			2. Two-product concentration	200-10	classifiers
VI	Steam	to 0.5 mm	1. Preparation of charge	200-10 10-0	screens crushers
			2. Two-product concentration	200-10	classifiers
			3. Two-product concentration	10-0.5	jigs
VII	Steam	to 0 mm	1. Preparation of charge	200-10 10-0	screens crushers
			2. Two-product concentration	200-10	classifiers
			3. Two-product concentration	10-0.5	jigs
			4. Two-product concentration	0.5-0	flotation machines

The choice of a technological model in a planned coal preparation plant is determined primarily by economic factors, i.e. maximum value of production and minimum investment and production costs.

Figure 7.1 gives an example of a coking-coal preparation plant flowsheet for concentrating coal to 0 mm, and Fig. 7.2 explains the notation used in Fig. 7.1 and in the following figures. This plant consists of the following six technological sections:

- preparation of 50–0 mm feed with selective crushing of + 50 mm fractions in Bradford breakers
- three-product concentration of 50–0.5 mm class in jigs
- three-product secondary concentration of the intermediate 20–0.5 mm product in Stamicarbon cyclones
- water-slurry circulation with flotation of 0.5–0 mm slurry
- drying of 0.5–0 mm flotation concentrate
- loading of final products (concentrates, intermediate products, waste).

Figure 7.3 gives an example of a technological flowsheet for a plant processing steam coal to 10 mm. This plant consists of the following four sections:

- preparation of 200–10 mm and 10–40 mm feed with non-selective crushing of coal above 200 mm to below 200 mm size
- two-product concentration of 200–10 mm class in separators with final classification of the 200–10 mm concentrate into two classes, 200–50 mm and 50–10 mm
- water-slurry circulation with clarification of washery water in radial thickeners and filtration of 0.5–0 mm slurry in vacuum filters
- final products loading (concentrates, raw fines, waste).

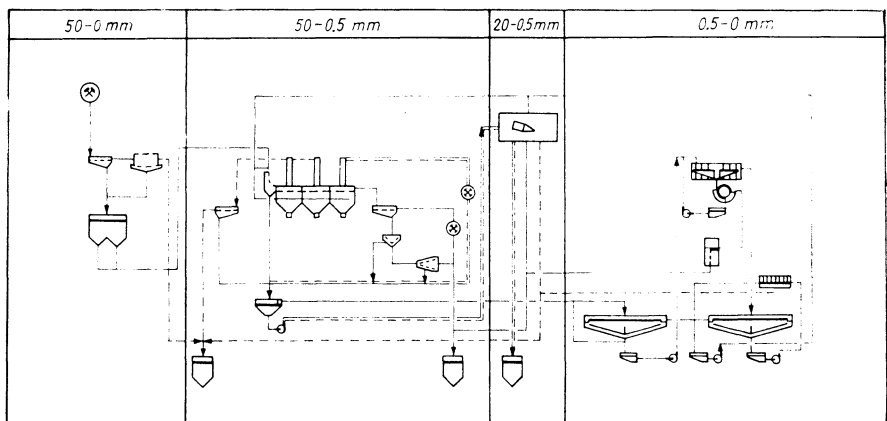

Fig. 7.1 Coking coal preparation plant flowsheet. Range of concentration to 0 mm.















<i>SYMBOL</i>	<i>ITEM</i>	<i>SYMBOL</i>	<i>ITEM</i>
	<i>Picking belt</i>		<i>Vertical drainer</i>
	<i>Selective crusher</i>		<i>Horizontal drainer</i>
	<i>Jaw crusher</i>		<i>Recuperator</i>
	<i>Hammer crusher</i>		<i>Filter</i>
	<i>Classifier</i>		<i>Filter press</i>
	<i>Two-product jig</i>		<i>Dryer</i>
	<i>Three-product jig</i>		<i>Suspensions tank</i>
	<i>Flotation machine</i>		<i>Classification sump</i>
	<i>Hydrocyclone</i>		<i>Pump sump</i>
	<i>Arc sieve</i>		<i>DORR thickener</i>
	<i>Screen</i>		<i>Pump</i>
	<i>Dewatering screen</i>		<i>Tank</i>
	<i>Centrifugal dewatering screen</i>		<i>Tank</i>

Fig. 7.2 Symbols used in Figs. 7.1, 7.3, 7.4.

Another example of a plant treating steam coal to 0 mm is given in Fig. 7.4. This plant consists of five technological sections:

- preparation of 200–10 mm and 10–0 mm feed (as in Fig. 7.3)
- two-product concentration of 200–10 mm class (as in Fig. 7.3)
- two-product concentration of 10–0.5 mm class in jigs with dewatering of concentrate in centrifugal dewatering screens (e.g. OSO type of Polish production) and in dewaterers.

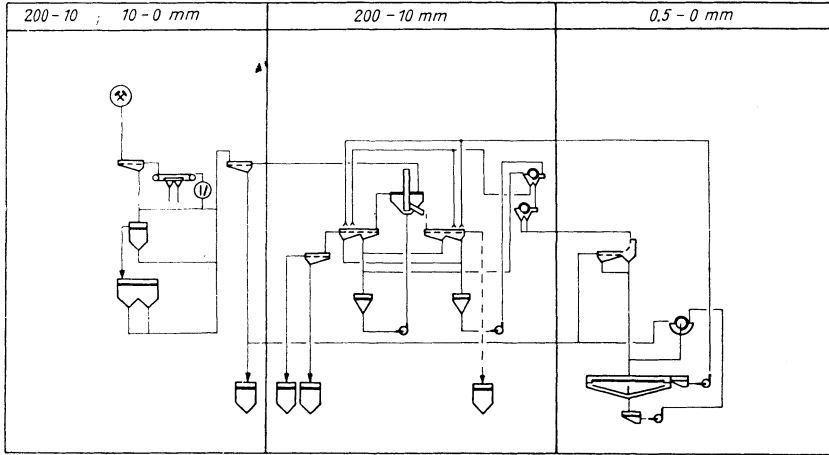

Fig. 7.3 Steam coal preparation plant flowsheet. Range of concentration to 10 mm.

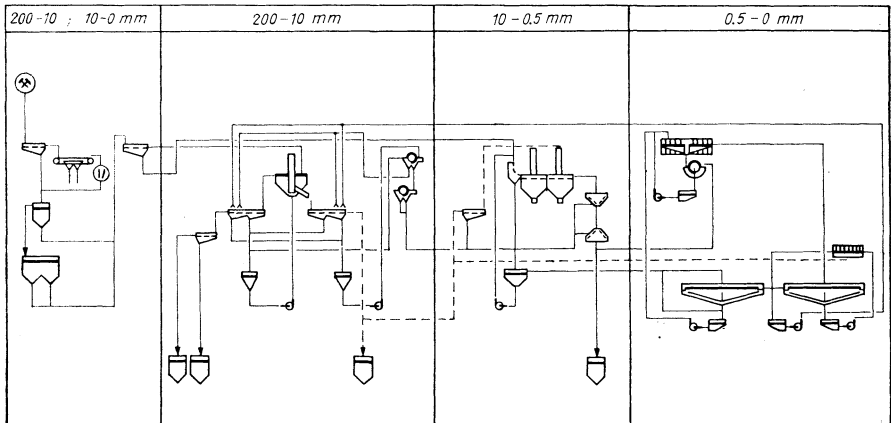

Fig. 7.4 Steam coal preparation plant flowsheet. Range of concentration to 0 mm.

- water-slurry circulation with flotation of 0.5–0 mm slurry, filtration of flotation concentrate in vacuum filters and filtration of waste in filter presses
- final product loading section.

Figures 7.5 to 7.9 give examples of spatial layouts for basic machines in the feed preparation and concentration sections. These are examples of coal preparation plants recently constructed in Poland or plants constructed in other countries from Polish designs. The machines layout shown in Fig. 7.9 uses gravity delivery of the feed to both primary and secondary cyclones

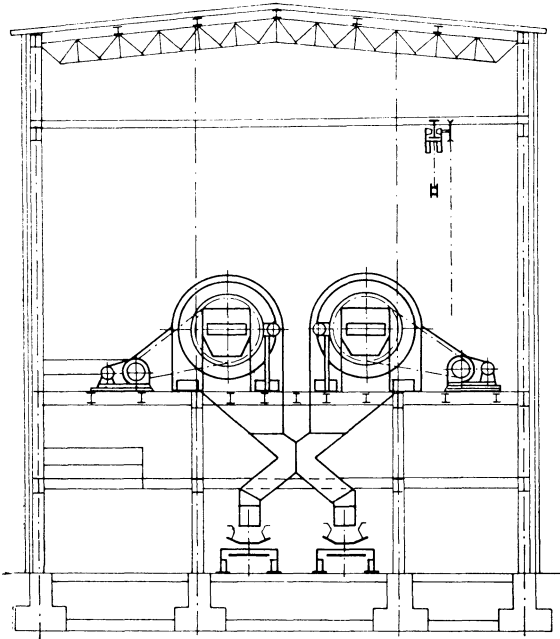

Fig. 7.5 Spatial arrangement of Bradford breakers in 50-0 mm feed preparation section.

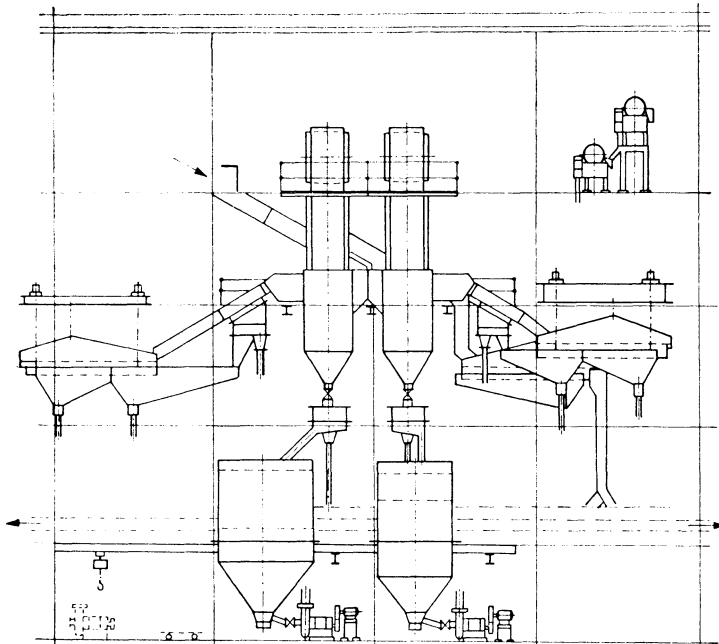

Fig. 7.6 Spatial arrangement of Disa two-product classifier, draining screens and tanks in class 200-10 mm concentration section.

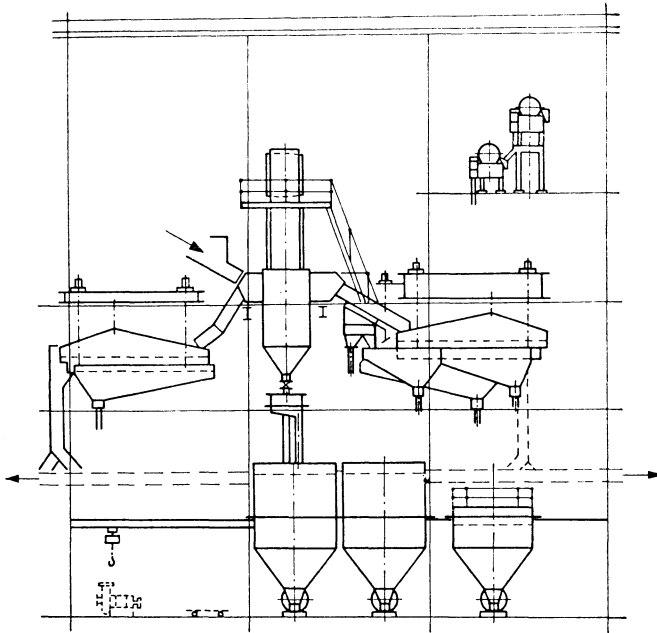

Fig. 7.7 Spatial arrangement of Disa three-product classifier, draining screens and tanks in class 200-10 mm concentration section.

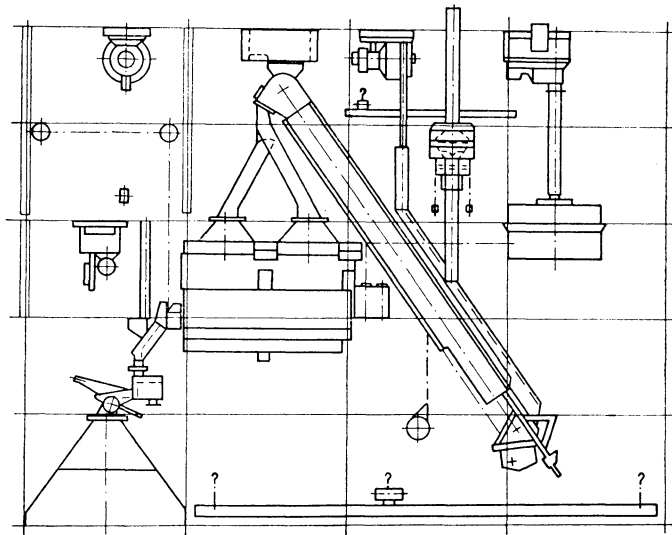

Fig. 7.8 Spatial arrangement of two-product jig, OSO centrifugal screen and drainer in class 10-0.5 mm concentration section.

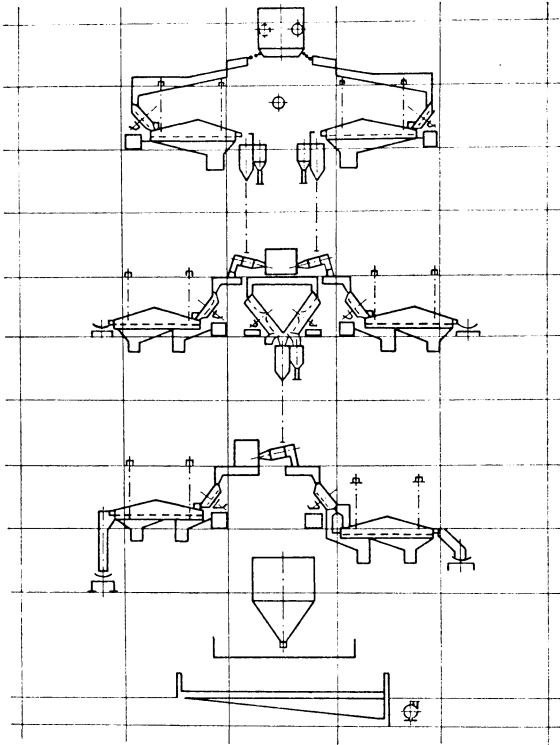

Fig. 7.9 Spatial arrangement of cyclones, desliming screens and draining screens in three-product 10–0.5 mm concentration section.

(eliminating the pumping of feed to the secondary cyclones). This system was installed in the preparation plant at the “Monidih” mine in India (throughput 700 t/h) which was designed in the Chief Mining Studies and Design Office in Katowice, while construction was supervised by the Polish designers.

Figures 7.10 to 7.12 show parts of new coking coal preparation plants constructed during the last few years in the Rybnik Coal Mining Region.

The coking-coal preparation plant of 1600 t/h capacity at the “Krupiński” mine was commissioned in 1983. Figure 7.13 gives the general plan and Figure 7.14 shows a part of the plant (on the left—circular raw-coal bunkers, on the right—preparation complex).

The stages of the coal preparation process at the “Krupiński” mine are as follows:

- preparation of 50–0 mm feed based on selective crushing using drum crushers

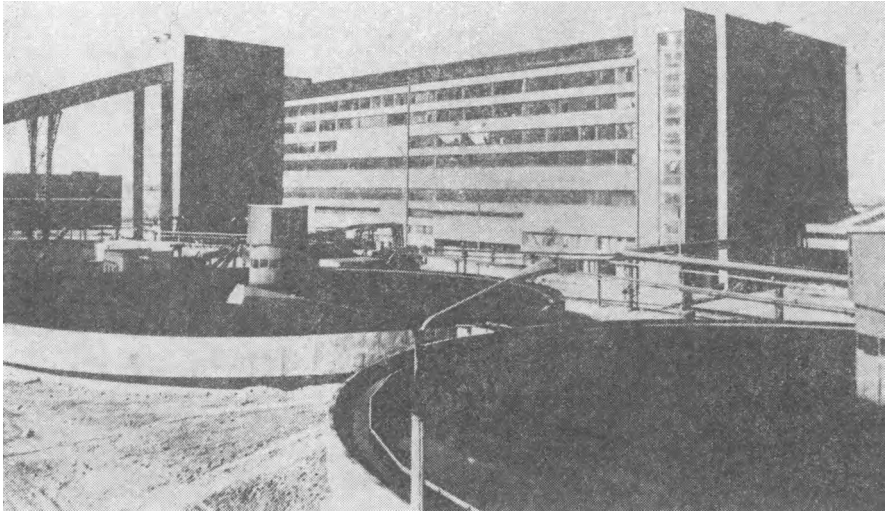

Fig. 7.10 Coking coal preparation plant at the “XXX-lecia PRL” mine. Throughput 1700 t/h. Commissioned in 1976. Foreground—40 m diameter desliming tanks.

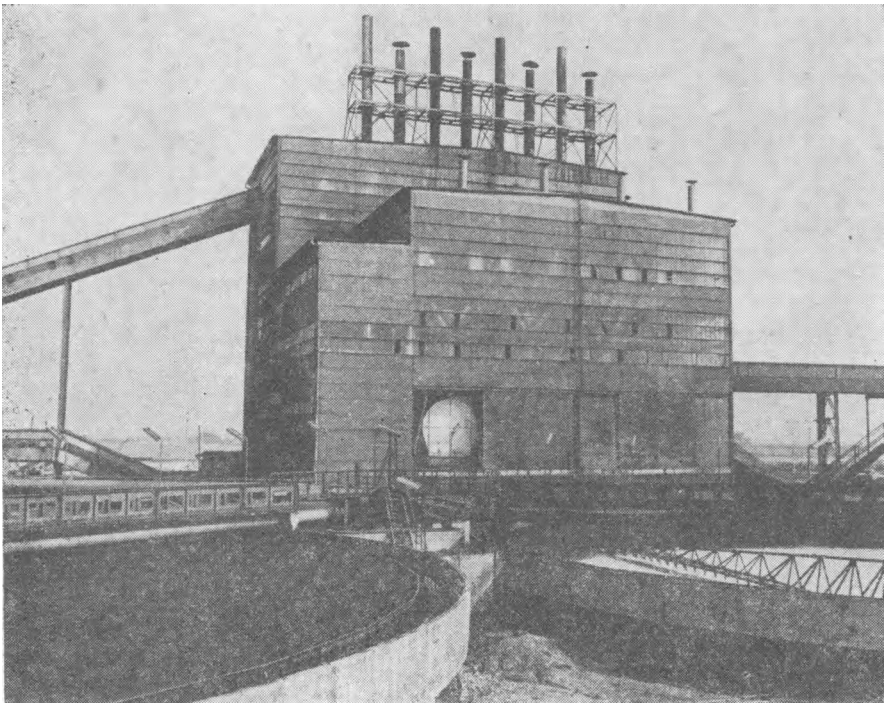

Fig. 7.11 Drying plant for flotation concentrate in the coal preparation plant shown in Fig. 7.10.

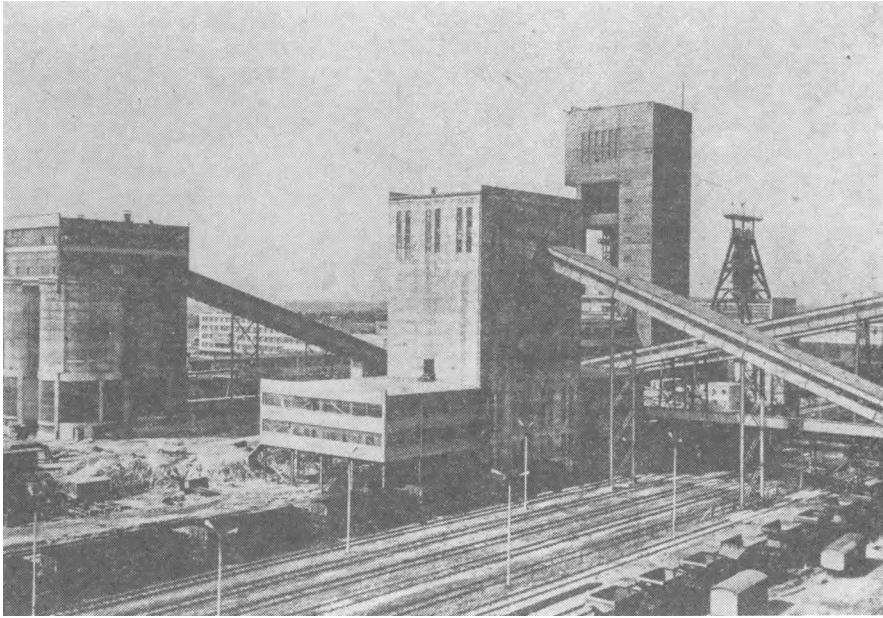

Fig. 7.12 Raw coal bunkers (left) and concentrated products bunkers. Coal loading station in coking coal preparation plant at the "Borynia" mine. Plant throughput 1700 t/h. Commissioned 1975.

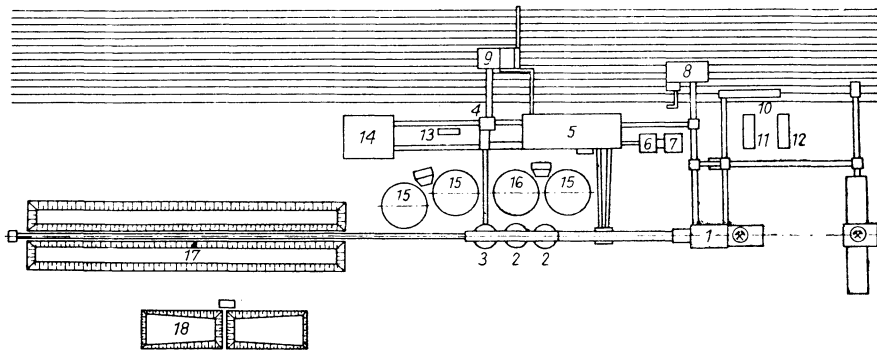

Fig. 7.13 General plan of coking coal preparation plant at the "Krupiński" mine. Throughput 1600 t/h. Commissioned 1983; 1—coal feed preparation station; 2—raw coal bunkers; 3—concentrate bunkers; 4—dry flotation concentrate bunker; 5—main concentration facility; 6—central control room; 7—laboratory; 8—waste products loading station; 9—ready products loading station; 10—bunker for coal from other mines; 11—store; 12—open-sided store; 13—reagents station; 14—drying plant; 15—radial thickeners; 16—waste water settling tanks; 17—concentrate tips; 18—waste water reservoirs.

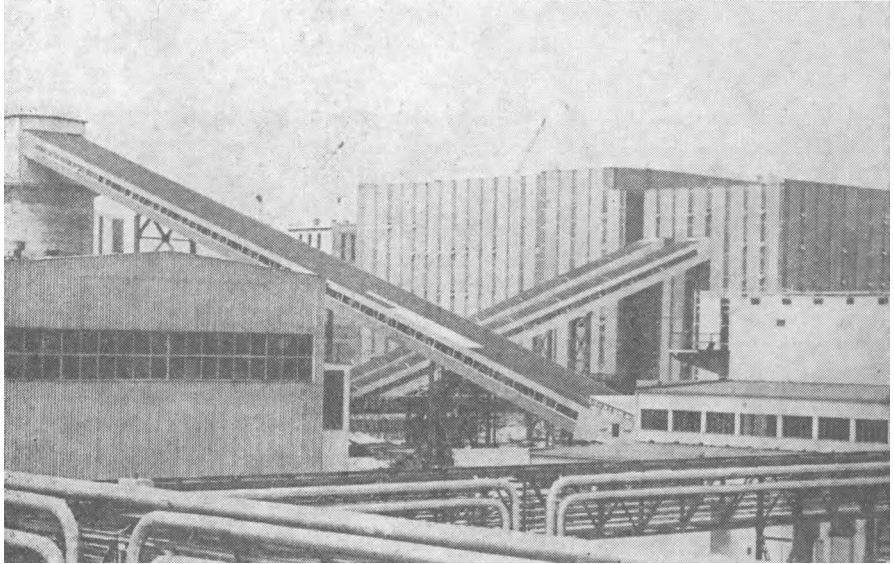

Fig. 7.14 View of preparation plant at the "Krupiński" mine. Left: raw coal bunkers. Right: preparation building (see general plan, Fig. 7.13).

- three-product concentration of 50–0.5 mm class in jigs
- two-product concentration of 0.5–0 mm class in flotation machines.

The capacities of basic technological sections are:

- |   |            |
|---|------------|
| — feed preparation section              | 1 600 t/h  |
| — 50–0.5 mm class concentration section | 1 250 t/h  |
| — 0.5–0 mm class concentration section  | 350 t/h    |
| — 0.5–0 mm concentrate drying section   | 280 t/h    |
| — concentrate loading section           | 2 000 t/h. |

The plant has the following technical parameters:

- |   |                        |
|---|------------------------|
| — net production                                | 12 000 t/d             |
| — gross production                              | 1 600 t/h              |
| — working time                                  | 16 h/d                 |
| — total cubic capacity of facilities            | 371 794 m <sup>3</sup> |
| — total cubic capacity of buildings             | 272 000 m <sup>3</sup> |
| — weight of steel structure                     | 6 386 t                |
| — weight of machines and equipment              | 6 700 t                |
| — total length of belt-conveyor support bridges | 1 507 m                |
| — installed power                               | 19 100 kW.             |

The basic facilities of the coal preparation plant such as the feed prep-



aration station, the complex preparation block and the drying plant are of steel structure with walls of laminated plates with trapeze sheet-metal reinforcements. Large "Vitrolit" surfaces used instead of traditional windows ensure natural lighting inside the buildings. Components of walls, roofs and conveyor bridges are made from prefabricated laminated panels. Units in contact with water such as ready-product bunkers, radial thickeners, pit sumps, flotation agents, stores, etc., are of monolithic reinforced concrete manufactured by sliding shuttering or relocatable boarding. All machines and equipment are controlled from a central command post and technological interlocking is provided. The design also includes local control of individual machines by apparatus at the operator's station.

The following measurements and control systems provide control of the technological process:

- control of charging and discharging of raw-coal bunkers
- stabilization of quantity of coal delivered to jigs
- stabilization of quantity of feed delivered to the dryers
- loading of final concentration products
- continuous measurement of moisture and ash content in 20–0 mm concentrate
- balance measurements of products
- industrial TV in the feed preparation section and the loading section
- central data recording.

The balance of products from the plant is:

- gross delivery to the plant (R.O.M.) 100%
- waste 45%
- net product 55%
- gross yield of final products
  - concentrate 20–0 mm 48%
  - middlings 10–0 mm 7%
  - waste 45%

Consumption of basic process materials is:

- flotation agent 6 t/d
- fuel for dryers 115 t/d
- flocculant 0.1 t/d
- fresh water for the process 1 600 m<sup>3</sup>/d

The preparation plant at the "Krupiński" mine achieves good technical and economic indices, comparing favourably with those in other coking-coal preparation plants of similar production capacity. High output machines and equipment are used in accordance with up-to-date opinions on optimum size and capacity of hard-coal preparation plants.

Table 7.4 gives a summary of basic preparation machines used in Polish plants in systems of 1000 t/h production capacity.

TABLE 7.4 Basic high-output machines used in Polish coal preparation plants of 1000 t/h throughput

Technological section	Technological process	Type of machine	Capacity
Preparation of charge 200–20 mm and 20–0 mm	1. Preliminary classification $\varnothing$ 200 mm	Vibrating screen WK1–2.6 $\times$ 5	1000 t/h
	2. Non-selective crushing of class + 200 mm to class – 200 mm	Jaw-crusher KWK-100 U	150 t/h
	3. Preliminary classification $\varnothing$ 20 mm	Vibrating screen PZ-3095	1000 t/h
Concentration of class 200–20 mm	1. Concentration	Separator DISA-4000	400 t/h
	2. Dewatering of concentration products	Vibrating screen PWP1-3,0 $\times$ 5	300 t/h
Concentration of class 20–0.5 mm	1. Concentration	Piston-less jig MO-24	500 t/h
	2. Preliminary dewatering of concentrate	Centrifugal dewatering screen OSO-3200	1600 m <sup>3</sup> /h
	3. Final dewatering of concentrate	Vibrating drainer WOW-1,5	350 t/h
Water-slurry circulation	1. Clarification of washery wastes	Dorr thickener, diameter 45 m	1600 m <sup>3</sup> /h
	2. Flotation of slurry 0.5–0 mm	Pneumatic-mechanical flotation machine IZ-12	900 m <sup>3</sup> /h
	3. Filtration of flotation concentrate	Vacuum filter of area 150 sq. m	40 t/h
	4. Clarification of flotation waters	Dorr thickener, diameter 45 m	1300 m <sup>3</sup> /h
	5. Filtration of flotation waste	Filtration press ROW-570	10 t/h

## 7.6 Technical and Economic Indices

The economic effects achieved by a preparation plant may be measured by the following data, quoted relative to unit plant production of 1 tonne per hour:

— weight of machines and equipment t

- installed power kW
- cubic capacity of buildings m<sup>3</sup>
- employment persons

and production costs per tonne of coal concentrate.

The value of these indices depends on the production capacity of the plant, the range of concentration and the type of technological sections.

Table 7.5 gives the approximate technical and economic indices for preparation plants constructed according to models III and V listed in Table 7.3.

In general, plants with capacity of about 2 000 tonnes per hour exhibit technical and economic indices about 20–30% better than those of 1 000 t/h plants using similar concentration technology.

TABLE 7.5 Basic technico-economic indices of preparation plants according to technological models III and V from Table 7.3

Specification	Units	Technological model according to Table 7.3			
		III	III	V	V
Plant output	t/h	1000	2000	1000	2000
Concentration range	mm	to 0	to 0	to 10	to 10
Weight of machinery and equipment	t · h/t	6.5	4.5	1.8	1.4
Installed power	kW · h/t	17.0	12.0	4.0	3.0
Cubic capacity of buildings	m <sup>3</sup> · h/t	280.0	200.0	70.0	60.0
Employment	men · h/t	0.2	0.15	0.14	0.13
Investment expenditure	%	100	70	35	20
Production costs	%	100	80	30	20

The capital demand for plants of 1000 t/h capacity concentrating coal to 0 mm size is about 40% greater than when concentrating to 0.5 mm, and 80% greater than when concentrating to 10 mm.

The most expensive of the individual technological sections is the water-slurry circulation section with flotation of slurry and dewatering of flotation waste in filtration presses, while the cheapest is the feed-preparation section.

The largest production costs are incurred in the 0.5–0 mm concentrate-drying section and the smallest in the feed preparation section.

The materials and energy consumption indices of the basic preparation machines are worth consideration. The *materials consumption index* is taken as the ratio of weight of machine including ancillary equipment (t) to nominal

output (t/h). *Energy consumption index* is taken as the ratio of the installed power of machine plus ancillary equipment (kW) to its nominal output. These indices influence the price of the machines and, to a certain extent, the overall investment costs.

TABLE 7.6 Material and power consumption indices of basic machines including auxiliary equipment in concentration sections for classes 200–10 and 10–0.5 and 0.5–0 and in concentrate 0.5–0 mm drying section

Technological sections	Type of machinery and production capacity, t/h	Index	
		Materials consumption t · h/t	Power consumption kW · h/t
Concentration of class 200–10 mm	Classifier, 300	0.2	0.3
	Dewatering screen, 150	0.03	0.08
Concentration of class 10–0.5 mm	Jig, 500	0.3	1.0
	Drainer, 250	0.03	0.2
Concentration of class 0.5–0 mm	Flotation machine, 100	0.5	1.8
	Vacuum filter, 40	1.2	6.3
	Sedimentation centrifuge, 25	0.7	7.2
	Filtration press, 8	19.4	13.4
Concentrate drying	Dryer, 70	3.9	9.3

In general, indices of materials and energy consumption increase with the increased range of concentration. Table 7.6 shows indices of materials and energy consumption for machines, complete with ancillary equipment, in the sections preparing classes 200–10, 10–0.5 and 0.5–0 mm and for drying of 0.5–0 mm concentrate. The highest indices for both materials and energy consumption are found for the machines in the water-slurry circulation and for drying of the 0.5–0 mm concentrate.

## Chapter 8

### Energy Management in Mine Design

Both the technology and technical means for coal winning have developed remarkably since the war. Concentration of production and mechanization of exploratory, development, production and auxiliary working have advanced significantly. This has naturally been accompanied by a systematic rise in consumption of energy in its various forms. At the same time coal is being extracted to ever greater depths in steadily deteriorating mining and geological conditions, resulting in continual increase of energy consumption. A marked increase in the share of energy costs in the total unit costs of coal extraction is evident. The problem of energy supply to the mines and to individual receivers is becoming particularly important. This also includes the selection of suitable machines and installations, their proper utilization and energy losses. The overall investment in supply and economic utilization of energy in the mines is known as *energy management*.

Energy economy in the mine should be subjected to comprehensive analysis in a multivariant scheme as early as the stage of conceptual design. It must also be considered during the preparation of technical designs, choosing the variant giving the lowest index of energy consumption as well as the lowest investment and operational costs, whilst ensuring reliability of operation and complying with all the required safety regulations.

Analyses made at the conceptual design stage and during the elaboration of the technical and economic design principles should make it possible to decide on the choice of most suitable energy carriers and of most favourable technical and technological designs from both the energy and economic aspects. Analyses should be based on indices of unit power consumption measured directly for individual machines and equipment and for whole technological sections in mines with varied geological and mining conditions and various technological and technical characteristics.

The designed energy supply systems should be very reliable since losses caused by interruption in energy supply are comparatively large and as a rule difficult to make up. The reliability of energy supply is essential in mines with a methane hazard.

Energy consumption in hard-coal mines depends not only on direct production processes (coal getting, district and main haulage, winding) and coal preparation but also, to a great extent, on non-production processes such as drainage, ventilation, heating of downcast shafts and surface structures, air conditioning of working faces in very deep mines, lighting, etc. All these sectors, both production and non-production, should be analysed and designed with equal care.

## 8.1 Electric Energy Management

### 8.1.1 *Balance of Electric Power and Energy*

The basic electric energy parameters of the mine at the so-called common point of connection to the national grid and also energy distribution inside the mine have to be known before specifying the requirements for the supply source.

The starting point is the balance of electric energy and power prepared at the conceptual design stage and within the framework of the technical and economic design principles. The method for balancing of electric power and energy given in this chapter should guarantee sufficient accuracy.

In designs for operating mines (modernization, reconstruction, extension) the balance of installed power and of electric energy is based on measurement data either specially prepared or from supplier's meter readings and internal plant readings. Certain values, such as demand power, are quoted for a one year period.

Since measurements performed over a whole year may be difficult, it is acceptable to limit the measurement period to not less than one month, with the proviso that this must be a period of high and stable production. Values for this shorter period are then factored up for a one-year period.

For newly designed mines electric power parameters are calculated on the basis of daily and yearly mine production (net), rated power of drives of the planned machines, equipment and other users and also their working time, applying appropriate values of factors and indices.

Use is made of the value of *installed power*, distinguishing *total installed power*  $P_i$  (kW) and *installed power of working machines and equipment*  $P_{ip}$  (kW).

Total installed power  $P_i$  is taken to mean the sum of the rated active powers

(kW) of all electric users in the mine (or given facility) without reserves in store. It expresses the overall state of equipment of the mine (or facility) with electric energy users.

The installed power of working machines and equipment  $P_{ip}$  refers to electric energy users in normal operation. Hence this value is less than  $P_i$  by the sum of the rated active powers of the electric energy users in reserve, undergoing repairs, etc. For calculation of electric energy indicators based on installed power the value of installed power of working machinery and equipment  $P_{ip}$  is always taken.

*Example.* The mine has 4 main drainage pumps: one pump with 1 000 kW electric motor in operation, two with 630 kW motors on stand-by and one with 630 kW motor under repair. In this case  $P_i = 2\,890$  kW,  $P_{ip} = 1\,000$  kW.

Another factor occurring in the power and energy balance is the *demand power*  $P_m$  (kW). For particular groups of consumer units the demand power is calculated from the formula

$$P_m = P_{ip}k_z, \quad (8.1)$$

where:  $k_z$ —demand power coefficient.

If the demand powers  $P_m$  are known (from measurements or calculations) and also the installed powers  $P_{ip}$ , then the demand factor  $k_z$  for particular groups of consumer units and for the whole mine is calculated from the ratio  $P_m : P_{ip}$ . When there are no measurement data then the factor  $k_z$  for a group of consumer units is calculated from the formula

$$k_z = \frac{k_w k_j}{\eta_m \eta_s}, \quad (8.2)$$

where:

$k_w$ —load factor, ratio of the power uptake by machinery driven to rated power of their driving motors

$k_j$ —coincidence factor of machines operation

$\eta_m$ —efficiency of motor

$\eta_s$ —efficiency of supply network.

Approximate values of  $k_z$  are given in Table 8.1.

The value of  $k_z$  for individual groups of consumer units or for a mine may also be determined from the statistical data from other mines with similar conditions. Table 8.1 gives approximate values of the factor  $k_z$  for characteristic groups of consumers in Polish hard-coal mines. Larger values refer to mines of high production and high production concentration and to drives of high power, except thyristor winding machines where the value of  $k_z$  decreases with increase in drive power.

TABLE 8.1 Demand power factor  $k_z$  and power factor  $\cos\varphi$  for characteristic groups of consumers and hard-coal mines in Poland

Group of consumers	Value of factors	
	$k_z$	$\cos\varphi$
Face machinery and equipment including district haulage	0.3–0.6	0.6–0.68
Main horizontal transport system		
— rail transport	0.4–0.55	0.7–0.75
— belt conveyor transport	0.6–0.7	0.7–0.75
Pit bottom facilities	0.35–0.5	0.6–0.65
Main drainage system	0.8	0.75–0.85
Total for mine underground sector:		
— including main drainage system	0.4–0.6	0.65–0.75
— excluding main drainage system	0.3–0.5	0.6–0.7
Vertical transport, winding installation:		
— single duty system	0.4–0.55	0.75–0.85*
— multi-duty system	0.4–0.45	0.75–0.85*
— with thyristor winding drive	0.45–0.65	0.45–0.65
— for transport of materials	0.15–0.3	0.75–0.85*
Pit top facilities	0.4–0.55	0.6–0.65
Main ventilation fans	0.8	0.8–0.9*
Coal preparation plant	0.55–0.65	0.67–0.74
Compressors	0.8	0.75–0.86*
Remaining consumers located at the surface sector	0.5–0.7	0.75–0.85
Total for the mine (surface and underground sectors)	0.4–0.6	0.7–0.75

Note: Values marked by \* refer to asynchronous motors. Values for synchronous motors must be fixed individually.

The demand power  $P_m$  for a mine is calculated as the sum of demand powers of all working groups of consumer units, taking into account non-coincidence of occurrence of peak loads, as in the formula

$$P_m = k_{jp} \sum P_{ip} k_z, \quad (8.3)$$

where  $k_{jp}$  represents the peak load build-up coefficient.

Figure 8.1 shows factor  $k_{jp}$  as a function of the sum of active demand power (peak)  $\sum P_m = \sum P_{ij} k_z$  based on data from Polish hard-coal mines.

For existing mines or groups of consumer units, peak powers are calculated from measurement data. These powers are 30-minute peak values. The measurement data may include peak powers averaged over other  $t$ -minute



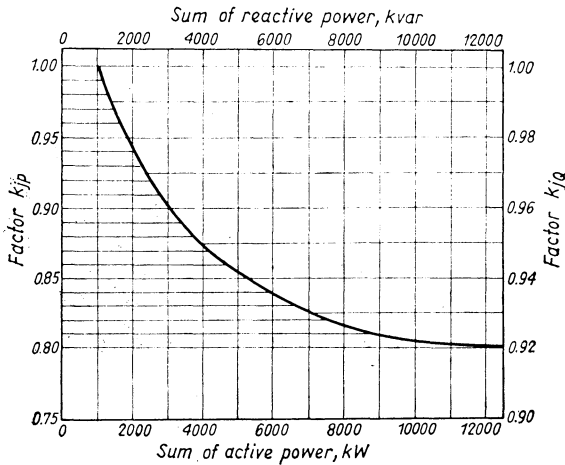

Fig. 8.1 Indices of superposition of peak load active powers  $k_{jp}$  and reactive powers  $k_{jq}$  as a function of sum of peak active powers  $\sum P_m = \sum P_{ij}k_z$  and peak reactive powers  $\sum Q_m = \sum P_m \tan \varphi_m$  (data from Polish hard-coal mines).

time periods (e.g. 15-minute peak powers  $P_{15m}$  taken from the maxigraph or 60-minute powers  $P_{60m}$  from balance measurements). In this case the measured  $t$ -minute value of peak power  $P_{tm}$  must be converted to the 30-minute peak power (demand power)  $P_m$  as in the formula

$$P_m = C_t P_{tm}, \quad (8.4)$$

where  $C_t$  is a factor whose value depends on the annual utilization time of  $t$ -minute peak power. The value of  $C_t$  may be read off from Figure 8.2. (Example: If 15-minute peak power is  $P_{15m} = 12\,260$  kW and yearly consumption of electric energy  $A_a = 56\,515\,000$  kWh, then the yearly period of utilization of power  $T_{15m} = A_a : P_{15m} = 4\,610$  h which on Fig. 8.2 corresponds to  $C_{15} = 0.861$ . Therefore (demand) peak power  $P_m = C_{15} P_{15m} = 10\,540$  kW.

The yearly time of use of demand power  $T_m$ (h) for a group of projected consumer units is:

$$T_m = T_d D_a, \quad (8.5)$$

where:

$T_d$ —number of working hours per day (fixed by the technological schedule, h/d)

$D_a$ —number of working days per year (for installations working also on non-production days  $D_a = 365$ ).

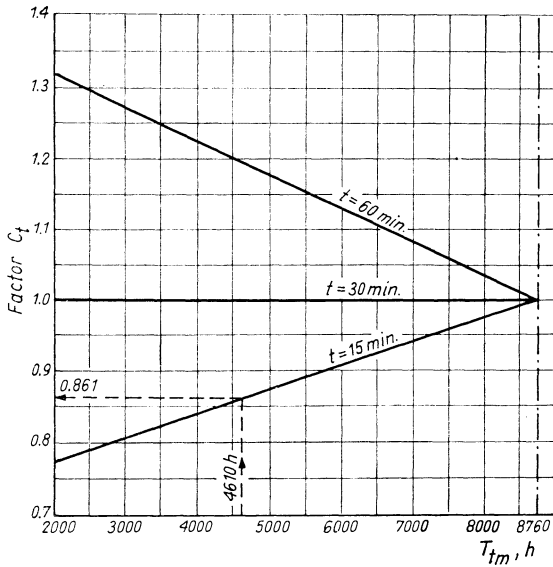

Fig. 8.2 The relation between factor  $C_t$  of the yearly time of utilization  $T_{tm}$  of  $t$ -minute peak power  $P_m$ .

For a new mine the yearly time  $T_m$  of utilization of the demand power  $P_m$  is:

$$T_m = \frac{A_a}{P_m} \quad (8.6)$$

where:  $A_a$ —yearly consumption of active energy in the whole mine, kWh.

For existing mines or groups of consumer units the annual time of utilization  $T_m = A_a : P_m$  is calculated from relevant measurement data.

The yearly consumption of energy  $A_a$  for particular groups of projected consumer units is calculated from formula (8.6). The yearly consumption of energy for the whole mine is the sum of annual energy uptakes by individual users ( $A_a = \sum P_m T_m$ ).

For existing mines and groups of consumer units the yearly consumption of energy is taken as the measured value of annual energy consumption or calculated from measurements over a shorter period (not less than one month) multiplied for the whole year.

The values of the power factor  $\cos \varphi$  are of great importance for electric energy management.

For particular groups of projected consumer units and for the whole mine, power factors are based on statistical data (Table 8.1). If measurement data or calculated values of active and reactive power are available, the power factors in peak period  $\cos \varphi_m$  are calculated from the relation

$$\cos \varphi_m = \frac{P_m}{\sqrt{P_m^2 + Q_m^2}}, \quad (8.7)$$

where:

$P_m$ —demand power, kW

$Q_m$ —reactive power at active loading peak, kvar

the  $P_m$  and  $Q_m$  values being 30-minute values.

For a group of projected consumer units, the reactive power  $Q_m$  in the peak period (kvar) can be calculated from the formula

$$Q_m = \pm P_m \tan \varphi_m = \pm P_m \sqrt{\frac{1}{\cos^2 \varphi_m} - 1}, \quad (8.8)$$

where  $\tan \varphi_m$  and  $\cos \varphi_m$  are trigonometric functions of the phase displacement angle  $\varphi$  at active loading peak. The  $\pm$  sign refers to the type of load (+ for inductive and – for capacitance type users, e.g. counterexcited synchronous motors).

The value of peak reactive power for the whole mine is calculated as the algebraic sum of reactive powers of all operating groups of consumer units, taking into account the non-coincidence of occurrence of peak loads, from the formula

$$Q_m = k_{jq} \sum (\pm (P_m \tan \varphi_m) - Q_k), \quad (8.9)$$

where:

$k_{jq}$ —coefficient read off from the graph (Fig. 8.1), depending on the sum of the peak reactive powers of all operating groups of consumer units

$Q_k$ —reactive power of all operating static condenser batteries installed to correct the power factor, kvar.

For working mines and consumer groups, the peak reactive powers are determined from measurements. The unit electric energy indicators are calculated from the calculated or measured values of electric power and electric energy consumed, i.e. values of  $P_{ip}$ ,  $P_m$  and  $A_a$  per net tonne of coal produced.

### 8.1.2 Unit Electric Energy Indicators and the Structure of Consumption

Unit consumption of electric energy (kWh per net tonne) in coal mines depends principally on the mining and geological conditions, the depth of the mine, the types of technology applied (particularly coal preparation), the type of energy carrier and the degree of mechanization. In some countries with excess manpower and lack of resource, or lack of willingness to employ resources in the mechanization and modernization of production technologies, the unit

consumption of electric energy is several times lower than that in comparable mines employing modern technologies and a high standard of mechanization of production processes. Unit electric energy consumption is also markedly influenced by both concentration and volume of production (the indicator decreases with a rise in the value of these parameters), as well as by up-to-date construction and watt-hour efficiency of machines and equipment. Table 8.2 gives the appropriate values of unit electric energy consumption in Polish

TABLE 8.2 Unit consumption of electric power in Polish hard-coal mines

Mines	Consumption of electric power kW · h/t
Non-gassy mines with water inflow up to 5 m <sup>3</sup> /min	20–30
Non-gassy mines with water inflow over 5 m <sup>3</sup> /min	25–38
Gassy mines with average methane explosion hazard	37–50
Gassy mines with severe methane explosion hazard	50–80
Deep gassy mines with considerable water inflow and severe methane explosion hazard	80–110
Deep mines with considerable water inflow and gas and rock outbursts hazard	93–150

hard-coal mines operating in varied mining and geological conditions. These mines use modern technologies and maximum level of mechanization of mining work and safety measures. The electric power consumed for production of compressed air is also included. Energy consumption increases with increasing depth of the mines, increasing water inflows and methane hazard.

The structure of energy consumption is also largely differentiated. It depends on the system of seam extraction, machines and equipment used, the intensity of ventilation, the degree of watering of the mine, the length of workings, and the degree of coal concentration. Table 8.3 shows the structure of electric energy consumption in Polish hard-coal mines. Mean and extreme values for all the hard-coal mines are given.

The substantial differences between the extreme values occurring in different mines is noteworthy. For instance, maximum value of electric energy utilized for the production of compressed air is 12 times higher than the minimum (higher values occur in very gassy mines using compressed air driven equipment at the faces and for underground transport); in the case of vertical transport, these differences depend on the depth of the mines and in coal preparation they depend on the range of coal concentration.

TABLE 8.3 Structure of electric energy consumption in Polish hard-coal mines

Consumption purpose	Share in total consumption of electric power, %	
	Total for the mines	Extreme values for individual purposes
Production of compressed air	17.5	3.2–38.0
Vertical transport	13.5	7.6–16.7
Coal preparation	13.0	8.1–17.1
Main drainage	12.5	3.4–21.4
Main ventilation	12.5	9.9–12.8
Coal getting and coal haulage	25.0	12.8–32.8
Other consumers at the surface	6.0	5.0– 8.0

Values obtained from measurements in other mines may be used at the conceptual design stage when attempting to determine the value of peak power demand indicator  $k_z$ , peak power  $P_m$  and energy consumption  $A_a$ . This is acceptable when the same or similar mining-geological, technological and technical conditions are involved.

### 8.1.3 Supply Sources and Systems

A mine is required to have at least two independent sources of supply of electric energy. Each of these should be able to cover full power requirement in the case of failure of the other one. Two independent transmission lines must also be provided for every mine, each line being capable of delivering the full power requirement. With more than two supply lines, the remaining lines must ensure transmission of the full power in case of a line failure. This independence of supply has to be maintained along the whole energy transmission route, from the supply source to the main mine transformer distribution station and to the first category users (main fan, vertical manriding transport).

Two supply sources and systems are considered to be independent when breakdown of one does not cause any disturbances in the other. In some countries mines with high methane hazard are required to have three sources of supply. In Poland, three independent sources of supply are required for mines of IV category methane hazard (more than  $15 \text{ m}^3 \text{ CH}_4$  per tonne of gotten). The first two sources and supply systems must comply with the conditions specified above, the third source and transmission line (stand-by supply) should be capable of delivering the power required for the main ventilation fans.

#### 8.1.4 Choice of Voltage

The value of the demand power  $P_m$  (peak power) differs considerably between different hard-coal mines and different countries. This is true both of operating and projected mines. There are some mines with power requirements only a few MW and others with 80 MW. A suitable voltage must be chosen depending on the value of power transmitted. In this respect marked differences may be observed in world mining practice both as to voltage in power supply lines and in surface and underground distribution networks. Also the rated voltages of mining machines and equipment vary considerably from country to country.

Hard-coal mines currently being designed in Poland require power between 20 and 80 MW. Voltage of 110 kV is the most suitable and currently most often used for the transmission of this power in the Polish mines (Fig. 8.3). The distribution of electric power both at the surface and underground in the mines is based on 6 kV voltage system with insulated neutral point. Due to the size of modern mines and to the necessity of reducing the influence of thyristor winding machines on the 6 kV network, it is advantageous to use a 20 kV distribution network for supplying peripheral shafts and thyristor winding installations and a 6 kV network for the remaining groups of users at the mine surface and underground. For supplying power users at the mine surface 500 V is used (from stationary transformers installed close to the particular groups of users) and for supplying lighting installations and small power users a 380/220 V network with earthed neutral point is used. Higher voltage network components exhibit greater reliability. New designs of Polish mines are using 10 kV voltage instead of the 6 kV used previously.

#### 8.1.5 Distribution Network Systems

*Cable network.* A cable network is usually designed for distribution. In Poland, the 6 kV cable networks are being replaced in new designs by cables with insulation for a rated voltage of 10 kV to allow for the planned change to 10 kV voltage when suitable 10 kV electric motors are available.

The double-radial system is usually used for distribution. All the more important consumers are supplied by this system while the less important ones are supplied by the loop system.

The double-radial system consists of two single radial systems (transmission line-transformer, transmission line-motor) connected to independent sources of supply.

The loop system consists of stations connected along the supply line, which is supplied from two sides. It is possible to cut the line at any desired station.

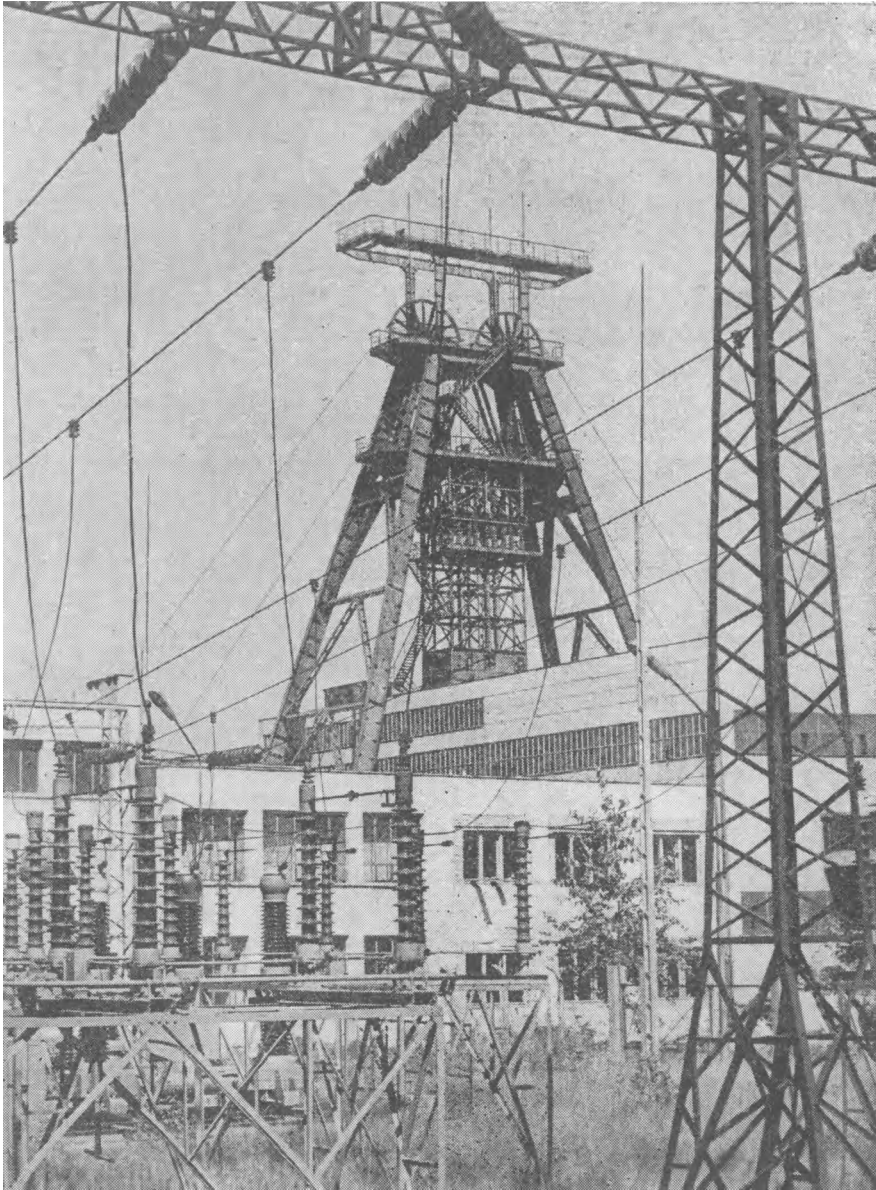

Fig. 8.3 110 kV substation switchgear at the "Staszic" mine.

Cable lines of the mine distribution network are laid in cable ducts, or on special platforms also used for technological pipelines, or more seldom in the ground. In newly designed mines the more important consumers are supplied by one cable line located on a platform and by a second laid in a cable duct, giving increased reliability.

To ensure reliability of power supply the transmission lines serving the mine underground sector are routed separately, i.e. cable lines are located in at least two separate shafts. Should one cable line fail the remaining lines must be capable of transmitting the total power required for basic supply.

Cables laid underground in the mines must comply with the requirements of the competent mining authority. In Poland this is the Ministry of Mining and Power. Cables normally in use in industry, usually with aluminium conductors, may be used at the surface. It is recommended to use cables sheathed and insulated with fire-resistant materials. When laying out cable routes care must be taken to comply with fire protection regulations.

Certain sections of cable lines are taken through ground affected by mining subsidence and here both cables and cable-joint boxes must be protected against tensile and compressive forces, e.g. by enclosing them in elastic PVC pipes or by suspending them from posts on steel ropes.

*Transformer-Distribution Stations.* Hard-coal mines in Poland are supplied from the main 6/0, 5/0, 4/0, 23 kV transformer-distribution station sited near the 110 kV switchboard, in the weighted centre of the load system.

The design may call for one or two, and in special cases even three main transformer-distribution stations depending on the mine output, methane hazard and the number of transformers stepping down supply voltage (e.g. 110 kV) to distribution network voltage (e.g. 6 kV). These stations supply the main underground switchboards and local switchboards located in the preparation plant, compressor room near the winding machines, main ventilation fans, workshops, etc.

Metal-clad switchgear does not meet certain regulation requirements. The main transformer-distribution stations (in Poland 6 kV) are therefore provided with open construction two-system sectionalized switchgears with suitable insulation for the rated voltage (in Poland 6 kV). The switchboard structure is fabricated from steel sections, the walls between cubicles, the protection canopies and other partitions are fabricated from fire-resistant and arc-resistant materials. To improve operational reliability of the switchboard, two series connected isolating switches separated by a partition made of non-flammable material are used as a section switch. A similar partition divides the two systems of bus bars along their whole length. The sectionalized part



of the switchgear is screened to the whole height and width to protect the station against smoke in case of breakdown. In addition exhaust fans powered from an outside source (usually a set of batteries) are provided to extract smoke from the station.

Switchgear safety, signalling and interlocking circuits have 110 or 220 V DC supply. Two sets of 110 V or 220 V accumulators are provided in the station. One set supplies the auxiliary circuits of the 110 kV switchgear and the other the 6 kV switchgear, each being a reserve for the other. The station also has a control board with a display showing all the panels of the 110 kV switchgear and also the supply coupling panels of the 6 kV switchgear. The basement of the building houses 6/0.5 and 6/0, 4/0.23 kV transformers and if necessary also anti-short-circuit choking coils.

The transformer-distribution station building should be free-standing. In district stations the switchgear is of single system, sectionized or non-sectionized type with an open or enclosed cubicle construction.

For supplying electric machines and equipment underground a main switchgear station (in Poland 6 kV) is sited at the pit bottom of each extraction level. The main drainage pumps (if located at this level) and district switchboards are fed from this switchboard. The main underground switchboards are sited in the fresh-air current, and hence standard (non-flameproof) cubicles are utilized. In panels with a methane hazard district switchboards are of flameproof construction, in panels with no methane hazard they are of standard construction. Safety, signalling and interlocking systems have AC feed.

In gassy Polish mines power supply to districts or to a whole extraction level can be cut out if methane concentration exceeds the permissible level. The cutting-out operation is activated by special methanometric equipment.

#### *8.1.6 Choice of High Power Drives*

High power drives for machinery and equipment account for more than half of the mine installed and required power. These machines include: winding machines, main ventilation fans, air compressors and main drainage pumps. As an example, the drive powers of main installations in Polish coal mines may be as high as:

- winding machines — 7 200 kW (2 × 3 600 kW)
- air compressors — 6 800 kW
- fans — 3 150 kW
- pumps — 1 250 kW.

These power values and the specific operational requirements of these machines have a decisive influence on the choice of parameters of the electric energy supply and distribution network.

The choice of the drive motor power is governed by the machine's technological duty but the choice of drive type (asynchronous, synchronous, thyristor, Ward-Leonard, etc.) is governed by the network conditions at the machine site and the function of the drive in this network.

Winding machines present the most difficulties in the choice of drive type and adaptation to the technological duty. Winding machines of power over 1000 kW are driven by DC motors fed from rotary transformers (Ward-Leonard system) or from thyristor converters.

Until recently, air compressors (Figs. 8.4 and 8.5), fans (Fig. 8.6) and pumps (Fig. 5.14) were driven by asynchronous or synchronous motors of constant revolutions. Due to the development of semiconductor techniques wider control of drives revolution is becoming possible. Controlled revolution drives are introduced where this gives a reduced power consumption and improved technological efficiency. This type of drive is already in use in main ventilation fans where thyristor subsynchronous-cascade systems are used to control revolutions of drive motors. The control range is selected individually depending on the requirements and local fan working conditions. Drives for air compressors and pumps will also be equipped with synchronous cascade systems where it is technically and economically justified.

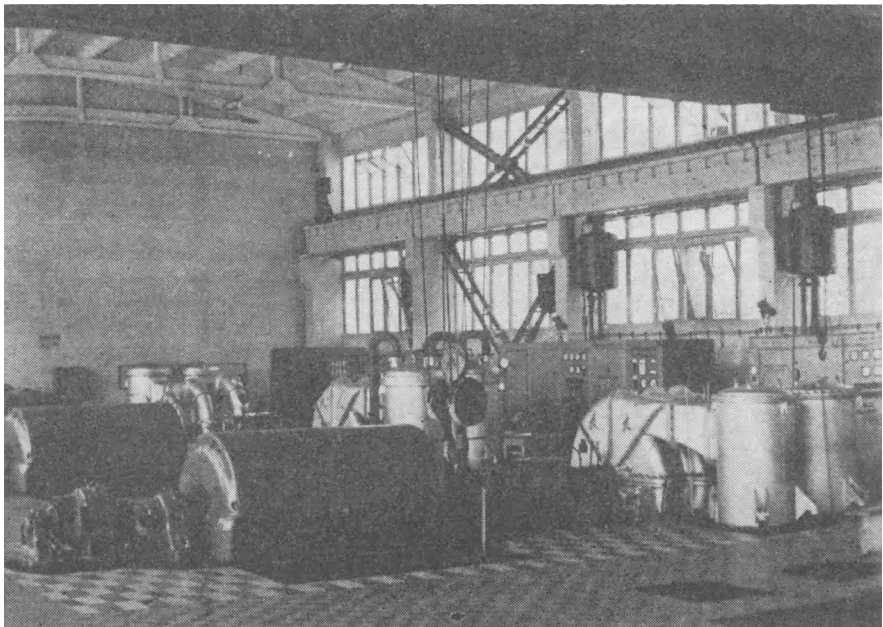

Fig. 8.4 Mine air compressors: output 34 500 m<sup>3</sup>/h, 7 500 rpm, air pressure 0.7 MPa. Electric motor 3 500 kW.

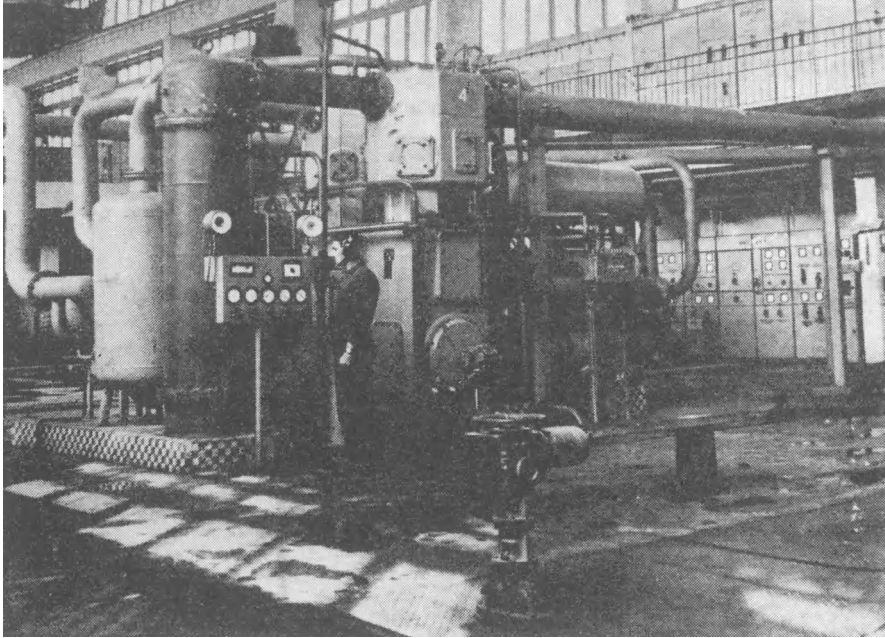

Fig. 8.5 Mine 5-stage piston air compressor. Output 2 800 m<sup>3</sup>/h, 493 rpm, air pressure 20 MPa, electric motor 800 kW.

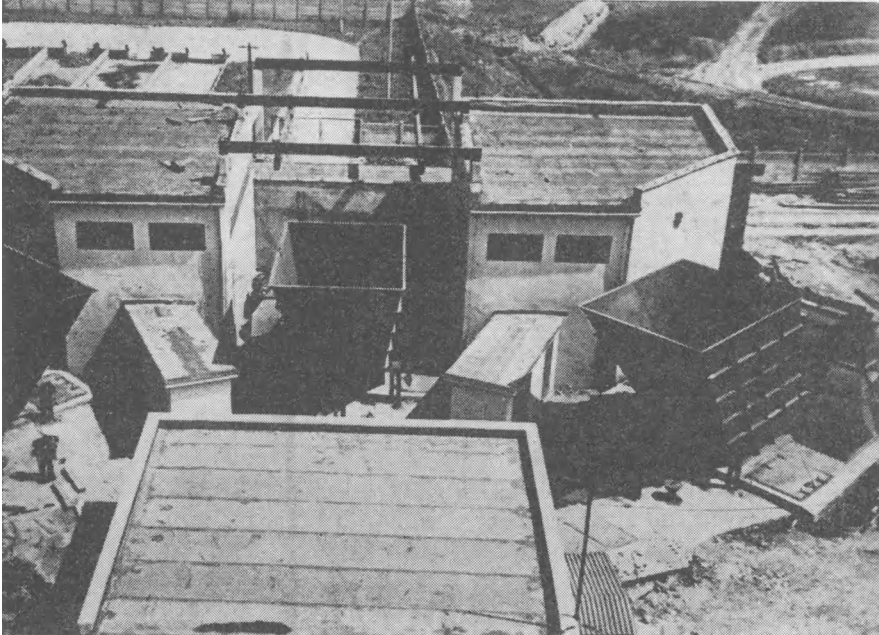

Fig. 8.6 Three-fan station. Fans of 16 000 m<sup>3</sup>/h capacity, 492 rpm. Electric motor 1 250 kW.

Thyristor drives for winding gears, despite their unquestionable advantages, i.e. lower electric energy consumption and better technical parameters than the traditional Ward-Leonard system drives, suffer from a major drawback. This is their effect on the supply network, in particular:

- notching at the primary of the converter transformer during commutation
- taking up of highly distorted current with consequent voltage distortion
- impact loading of reactive power network during starting up of winding machines causing voltage drop
- low mean power factor.

The extent of the unfavourable effects of thyristor drives on the feed network depends chiefly on the short-circuit capacity of this network, on drive powers and the structure of the converter system. Various requirements regarding the effects of thyristor drives on the feed network are in force in different countries. In Poland it is required that the notching should not be greater than 20% of voltage amplitude, distortion of supply power voltage curve should not be greater than 5% in the 6 kV network and 1.5% in 110 kV network, while the voltage drop caused by reactive power surges should not exceed 3% in the 6 kV and 1.5% in the 110 kV network.

The effects of the voltage curve distortion and voltage drop caused by reactive power surges may be reduced by the use of suitable higher harmonics filtration systems and follow-up compensation of the reactive power. A low level of notching may be ensured by providing a suitable short-circuit capacity of the switchgear busbar from which the converter drive is fed. Selection of suitable power for the 110/6 kV transformers can meet this requirement but this may lead to over-large transformers relative to the actual mine needs. Notching at the primary of the converter transformer will not exceed 20% if the short-circuit capacity  $S_{sc\ min}$  is greater or equal to a value:

$$S_{sc\ min} \geq \frac{4S_T}{u_z}, \quad (8.10)$$

where:

$S_T$ —converter transformer power

$u_z$ —relative value of converter transformer short-circuit voltage.

Due to the winding technology schedule, the converter drive most seriously affects the supply network during start-up. The largest consumption of reactive power for drives with simultaneous control of thyristor bridges is at the beginning of the start-up cycle, and for drives with sequence control this is near the middle of the start-up cycle.

Devices compensating the reactive power surges are calculated from the formula

$$Q_{\text{comp}} \geq Q_{\text{max}} - \frac{\Delta U_p S_{\text{sc}}}{110}, \quad (8.11)$$

where:

- $Q_{\text{max}}$ —maximum value of reactive power taken up by the drive, Mvar
- $\Delta U_p$ —permissible voltage drop caused by reactive power surges, %
- $S_{\text{sc}}$ —short-circuit capacity on the higher voltage side of converter transformers.

Voltage deformation caused by take-up of highly deformed current by drives depends on the number of bridges and the method of their control. The degree of deformation  $u$  (%) is calculated from the formula

$$u = \frac{100 \cdot 3 \gamma X_n}{U_n} \sqrt{\sum_{k=2}^{25} (J_k k)^2} \quad (8.12)$$

where:

- $U_n$ —rated voltage of network, V
- $\gamma$ —dissipation coefficient of higher harmonics
- $X_n$ —reactance of the feed network,  $\Omega$ /phase
- $J_k$ —harmonic value of  $k$ th order current, A
- $k$ —harmonic order.

Direct follow-up compensation of reactive power surges is currently effected as follows:

- using a battery of capacitors successively switched in to the network by means of thyristor switches as the reactive power taken up by the converter drive increases, and switched out as take-up of reactive power decreases
- using synchronous capacitors, in this case large synchronous motors for driving mining machines, equipped with special thyristor exciters with follow-up excitation control systems.

Limitation of higher harmonics in the mine power network is achieved by the use of filters for the 5, 7, 11 and 13 harmonics. As the current value of individual harmonics depends on a number of factors, the selection of filters must be made independently for each mine distribution network system.

Best results when selecting compensating and filtering devices are based on measurements of actual parameters of networks feeding the thyristor winding machines.

The choice of drives for pumps, fans and air compressors is a relatively simple matter but the correct choice of a winding machine for the technological duty is a very important design problem. The gotten has to be hoisted to the surface from a specified depth and in a specified length of time without exceeding technical parameters of the machine.

Winding machine basic parameters are:

- $D$ —diameter of the winding wheel, m
- $Q$ —lifting capacity, kN
- $V$ —steady hoisting speed, m/s
- $P$ —electric motor rated power, kW
- $M$ —electric motor effective torque, kNm
- $n$ —electric motor revolutions.

The symbols  $D$ ,  $Q$ ,  $V$ ,  $P$ ,  $M$  and  $n$  with subscript  $N$  denote nominal parameters while subscript  $z$  denotes calculated or assumed parameters. It is clear that calculated or assumed parameters may not be greater than nominal parameters and that  $D_z = D_N$ .

For design purposes the  $z$  parameters are evaluated as follows:

- (a) steady hoisting speed is assumed as  $V_z = V_N$
- (b) effective hoisting capacity is determined by the production schedule  
 $Q_z \leq Q_N$
- (c) winding wheel diameter is assumed  $D_z = D_N$
- (d) from available data the condition  $M_z \leq M_N$  is checked.

This condition gives:

$$M_N = 975 \frac{P_N}{n_N} \geq M_z = 975 \frac{P_z}{n_z} \quad (8.13)$$

and if  $D_z = D_N$  and  $V_z = V_N$  then  $n_z = n_N$ ; hence ultimately

$$P_N \geq P_z.$$

This procedure ensures that none of the nominal parameters of a chosen winding machine is exceeded and at the same time the hoisting duty is fulfilled.

Figure 8.7 gives the hoisting diagram of the winding machine and the corresponding effective torque of the winding motor. The hoisting diagram is described by the following formulae (general case, where acceleration  $a_1$  is not equal to retardation  $a_3$ ):

— start-up time, s

$$t_1 = \frac{V}{a_1} \quad (8.14)$$

— braking time, s

$$t_3 = \frac{V}{a_3} \quad (8.15)$$

— steady travel time, s

$$t_2 = \frac{H}{V} - \frac{V}{a} \quad (8.16)$$

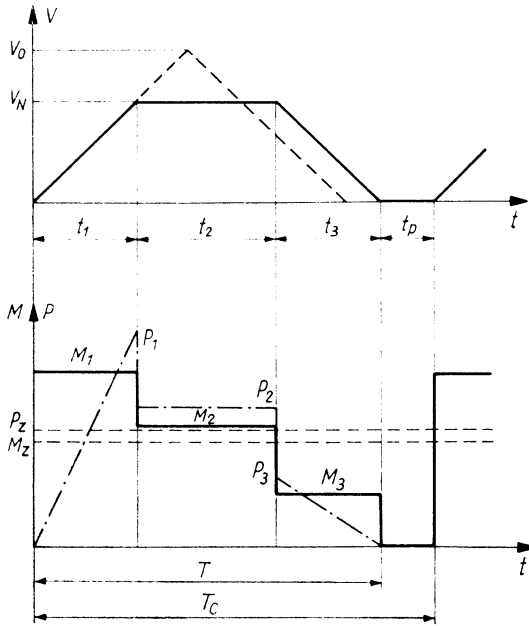

Fig. 8.7 Winding machine hoisting diagram.

— average acceleration,  $m/s^2$

$$a = 2 \frac{a_1 a_3}{a_1 + a_3} \quad (8.17)$$

— standstill time, s

$$t_p = f(Q) \quad (8.18)$$

— travel time, s

$$T = t_1 + t_2 + t_3 \quad (8.19)$$

— total cycle time, s

$$T_c = T + t_p. \quad (8.20)$$

Effective motor torque  $M$  (kNm) is related to the tension force in the rope  $F$  (kN)

$$M = \frac{D}{2} F. \quad (8.21)$$

In particular time intervals of the hoisting diagram the forces occurring in the rope are calculated (kN):

— start-up force

$$F_{st} = 1.18 Q + ma, \quad (8.22)$$

— static force

$$F_s = 1.18 Q, \quad (8.23)$$

— braking force

$$F_b = 1.18 Q - ma, \quad (8.24)$$

where:

$m$ —mobile mass, assumed as equivalent mass at the rope, a function of the lifting capacity  $Q$ , the shaft depth  $H$  and the ratio of skip capacity to skip weight including the suspension gear (this ratio is assumed to be constant and equal to 1.2)

1.18—a coefficient taking into account the shaft resistance.

The equivalent force  $F_e$  which determines winding machine loading is calculated from the formula

$$F_e = \left[ (F_{st}^2 t_1 + F_s^2 t_2 + F_b^2 t_3) \frac{0.01}{T_c} \right]^{\frac{1}{2}}. \quad (8.25)$$

Knowing values of the diameter  $D$  and of the force  $F_e$ , the equivalent effective torque  $M_e$  at the motor shaft (formula (8.21)) and the equivalent power  $P_e$  (kW) may be calculated as

$$P_e = 1.03 M_e n_N \cdot 10^{-4}, \quad (8.26)$$

which is the power developed at the hoisting motor shaft with nominal revolutions  $n_N$  and load from equivalent torque  $M_e$ .

The functions of lifting capacity  $f(Q)$ , and of lifting capacity and depth  $m(Q, H)$  in formulae (8.18) and (8.22)–(8.24) are empirical functions determined as

$$\begin{aligned} f(Q) &= 0.1 Q && \text{when } 100 \leq Q \leq 260, \\ f(Q) &= 10 + \sqrt{Q} && \text{when } Q > 260, \\ m &= 0.1(0.00279H + 4.0146)Q, \end{aligned}$$

where  $Q$  is given in kN and  $H$  in meters.

To calculate these values it is necessary to know  $D, Q, V, H, a_1$  and  $a_3$ . For practical purposes it is sufficient to know  $D, Q, V, H$  and  $a$ , where  $a$  may be calculated from formula (8.17), and substitute  $a_1 = a_3 = a$ .

Two values in this set, i.e. the acceleration and the hoisting speed, are subject to certain limitations. The maximum acceleration  $a$  is limited by the rope slip, and the minimum acceleration by economy in time of duration of the hoisting cycle. In preliminary calculations it is normally taken that



$0.9 \leq a \leq 1.1$ . The maximum steady hoisting speed  $V$  is limited by the acceleration  $a$  and the shaft depth  $H$  and the minimum speed by economy considerations. In general, it is taken that:

$$\frac{1}{2}\sqrt{Ha} \leq V \leq \sqrt{Ha},$$

where  $\sqrt{Ha} = V_0$  is the maximum speed in a triangular hoisting diagram (Fig. 8.7).

### 8.1.7 Example of Electric Power Supply and Distribution Design for a Gassy Coal Mine of High Production and Considerable Depth

#### Basic data

As an example of an electric power supply design is cited a very gassy Polish mine in the Upper Silesian Coal Mining Region. The daily production is 40 000 tonnes gross and 20 000 tonnes net. There are two extraction levels, the lower one being at a depth of 1 050 m. The mine has three production-manriding shafts and three ventilation (upcast) shafts. Shafts I, II, III are located at the main mine surface, two are downcast shafts and the third an upcast ventilation shaft. Shafts IV and V are perimeter ventilation shafts. Shaft IV is a production-manriding shaft sited at the auxiliary mine surface area, which takes over certain main mine surface functions.

#### Principal electric power consumers

The following are the principal consumers or groups of consumers:

1. *Winding machines.* There are eight winding machines, five with thyristor and three with Leonard drives, i.e.:

- three four-rope thyristor-drive skip-winding machines, each of 300 kN lifting capacity with two electric motors of 3 600 kW each
- two two-rope thyristor-drive cage-winding machines, each of 100 kN lifting capacity with two electric motors of 2 400 kW each
- three Leonard-drive cage-winding machines with 2 400 kW electric motors. Each is equipped with a converter whose generator is driven by two synchronous motors of 1900 kW each.

2. *Fans.* There are three two-fan ventilation stations, two at shafts IV and V with fans driven by asynchronous motors of 2 500 kW (6 kV) with revolutions controlled by thyristor cascades and one at shaft II with fans driven by synchronous motors of 1 600 kW (6 kV) each.

3. *Air compressors.* Four air compressors are situated at the mine surface and driven by synchronous motors of 2 100 kW (6 kV) each.

4. *Main drainage system.* The installed power of the main drainage pumps is 10 MW (6 kV).

5. *Coal preparation plant.* The installed power is 24 MW, the feed voltage is 20 and 6 kV. Some of the consumers are fed from 20/0.5 kV and 20/0.4/0.23 kV (9 MVA) transformers while all drives with 6 kV motors are fed directly from this voltage (7.2 MVA).

6. *Mine underground sector.* Total installed power of electric energy consumers installed underground is 45.2 MW.

7. *Remaining electric energy consumers.* This includes all consumers installed in the surface facilities such as workshops, stores, baths, lamp rooms, administration buildings, etc. Total installed power is 18 MW.

Tables 8.4 and 8.5 show the balance of power and of electric energy together with the basic electric energy indices of the given mine.

#### *Mine electric energy supply*

In view of the planned extraction of seams of IV category (methane hazard more than 15 m<sup>3</sup> CH<sub>4</sub> per tonne of gotten) the mine has two independent sources of power supply, each capable of delivering full power demand. There is also a third independent source of electric power which (according to Polish regulations) should guarantee at least the power demand of the main ventilation fans. These power sources are marked on Figs. 8.8 and 8.9 as *QI*, *QII* and *QIII*. All three have equal power delivery capabilities. Each source may take over the function of the main stand-by or emergency supplies as required.

The consumers at the main mine surface are fed from No. I and No. II 110/20/6 kV stations each with two 25 MVA transformers. These stations are supplied by the existing 110 kV grid network in the region of the mine. Similarly, consumers sited at the auxiliary mine surface (near shaft VI) are fed from this network but in the 110/20/6 kV station III two 16 MVA transformers are installed. Each of the windings of the 6 and 20 kV 110/20/6 kV transformers is connected to a separate section of the 6 or 20 kV switchboard with no possibility of working in parallel with the corresponding winding of the adjacent transformer.

TABLE 8.4 Balance of power and of electric energy

Consumers	Installed power of operating equipment $P_{lp}$ kW	$k_z$	$\cos \varphi$	$\tan \varphi$	Demand power $P_m$ kW	Reactive power $Q_m$ kvar	Yearly time of utilization of demand power $T_m$ h	Yearly consumption of electric power $A_e$ MW · h
Thyristor drive winding machines	26 400	0.57	0.7	1.02	15 120	15 450	4 000	60 480
Ward-Leonard drive winding machines	11 400	0.25	0.8	0.75	2 880	-9 120	2 500	7 200
Fans	11 600	0.8	0.89	0.51	9 280	4 720	8 760	81 290
Coal preparation plant	31 100	0.55	0.85	0.53	17 200	10 660	4 000	68 800
Compressors	8 400	0.8	0.71	1	6 720	-6 720	4 000	26 880
Methane drainage	500	0.8	0.8	0.75	400	300	6 000	2 400
Other consumers	28 500	0.6	0.75	0.88	17 100	15 050	3 000	51 300
Total for mine surface sector	117 900	—	0.92	0.42	68 700	28 600	4 343	298 350
Mine underground sector without main drainage	40 000	0.62	0.7	1.02	24 700	25 000	3 200	80 000
Main drainage*	11 000		0.8	0.75	2 300	1 730	6 200	14 260

Table 8.4 continued

Consumers	Installed power of operating equipment $P_{ip}$ kW	$k_x$	$\cos \varphi$	$\tan \varphi$	Demand power $P_m$ kW	Reactive power $Q_m$ kvar	Yearly time of utilization of demand power $T_m$ h	Yearly consumption of electric power $A_e$ MW·h
Total mine underground sector	51 000				24 700	25 000	3 816	94 260
Total for the mine	168 900				93 400	53 800		
Allowing for peak load coefficients $k_{JP} = 0.8, k_{JQ} = 0.92$	168 900	0.44	0.83	0.66	74 720	49 500	7 932	392 610
Including: — first category consumers — thyristor drive winding machines	23 500 26 400				14 860 15 120	2 370 15 450		

Note: \* operation at non-peak periods

TABLE 8.5 Basic electric energy indices

Index	Value
Net mine production	
— per day	20 000 t
— per year	5 900 000 t
Installed power of operating equipment $P_{lp}$	168 900 kW
Demand power $P_m$	74 720 kW
Demand power coefficient $k_x$	0.44
Power factor $\cos\varphi$	0.94
Unit installed power per t/day net output	8.44 kW
Unit demand power per t/day net output	3.74 kW
Yearly consumption of active power $A_a$	392 610 MW · h
Unit consumption of electric power	66.5 kW · h/t
Yearly utilization time of demand power $T_m$	5 254 h
Power of operating synchronous motors	17 600 kW
Demand power of first category consumers	14 860 kW
Installed power of thyristor drive machines	26 400 kW
Demand power of thyristor drive machines	15 120 kW
Installed power of operating fans	11 600 kW
Demand power of operating fans	9 280 kW

Ventilation shafts Nos. IV and V are fed by 20 kV cables lines and the third supply line required by regulations is an overhead line also of 20 kV. The thyristor winding machines are fed from the 20 kV switchboard as is a part of the preparation equipment. The remaining consumers are fed from the 6 kV network.

All hard-coal mines designed and constructed in Poland in the last few years have a 6 kV distribution network. Only very recently has the two-voltage network, i.e. 6 and 20 kV, as described in this example, been introduced for high-production mines with large power demand.

This arrangement has the following advantages:

- using the 20 kV network to feed the thyristor winding machines makes it possible to eliminate the higher harmonics filters in the 6 kV network
- follow-up compensation of reactive power surges is not necessary
- due to the distribution of a considerable proportion of the power demand via the 20 kV network it is possible to reduce cross-sections of cables, and hence energy losses
- reducing the shorting power on the 6 kV side allows the choking coils on the underground return lines to be eliminated.

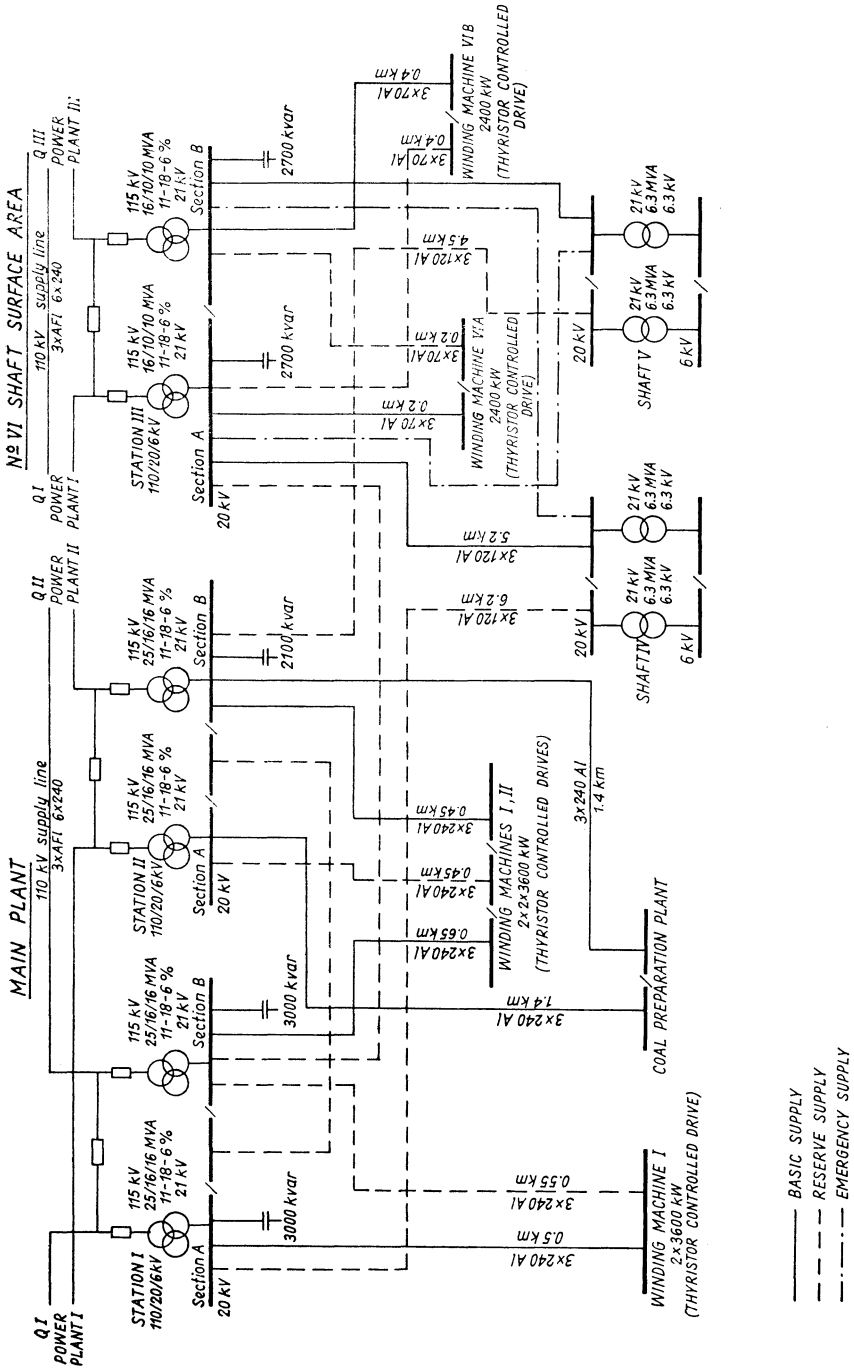

Fig. 8.8 Diagram of 6 kV network for a very deep gassy mine of high production capacity.

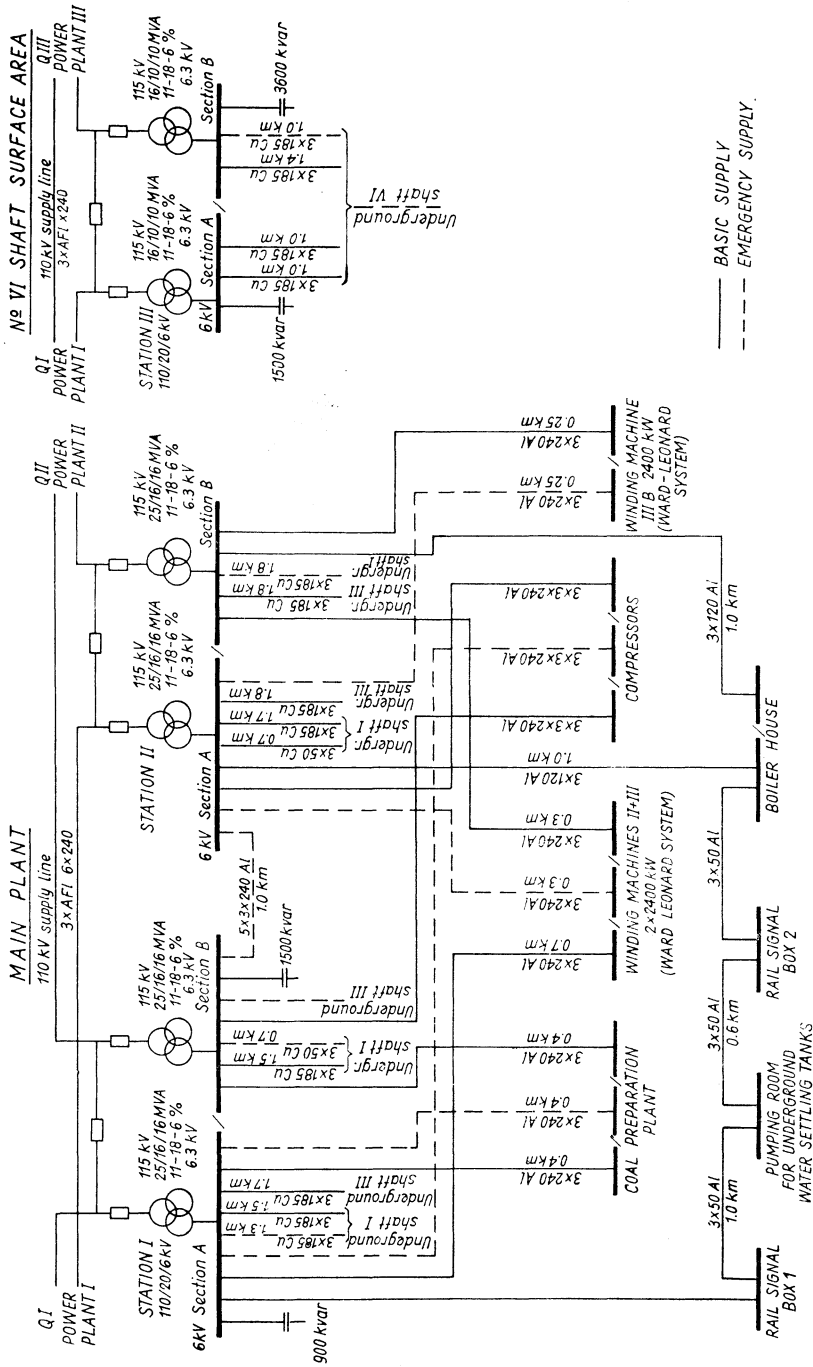

Fig. 8.9 Diagram of 20 kV network for mine as in Fig. 8.8.

## 8.2 Compressed Air Management

### 8.2.1 *Production and Application of Compressed Air in Hard-Coal Mines*

In comparison with other types of energy, and above all with electric energy, compressed air is the least economic energy carrier. The average operational efficiency of a compressed air installation system including air compressors, compressed air pipelines and energy consumers (air drives) in a mine is only about 10%. Consequently, there was a virtually universal trend in the post war years towards replacing pneumatic with electric drives. A systematic increase in electrification and limited use of compressed air in Poland can be noted. In Polish non-gassy mines, the index of electrification is 96–99% and in mines with methane hazard about 80%, but here it must be stressed that Polish mines are among the most gassy in Europe.

The present level of technical knowledge does not allow compressed air energy to be replaced entirely by electric energy, and hence the number of compressed air drives is still considerable, especially in gassy mines. Air driven machines and equipment are used principally for stone and stone/coal drivage and for drives and control of shaftside installations.

In gassy mines compressed air is produced by high capacity stationary compressors (in Poland up to 66 000 m<sup>3</sup>/h and 6.8 MW). These are installed at the surface in separate buildings. In non-gassy mines small capacity portable air compressors (100 kW) are used, located underground in the vicinity of the air-driven equipment.

In the existing installations various types of centrifugal and piston compressors driven by electric motors are used. Compressors with steam drives may still be found but are nowadays only museum pieces.

The economic centrifugal compressors with external cooling of the compressed air, driven by synchronous or asynchronous motors, are most often used in modern air installation.

Recently subsynchronous cascade systems have been introduced for control of revolutions, and hence of compressors' output. This gives a certain flexibility of operation which means reduced losses for choking when the compressed air demand changes.

Consumption of compressed air in Polish gassy mines varies from 120 to 200 m<sup>3</sup>/tonne of coal (net), depending on the degree of gassiness, the volume of production and the length of the compressed air network. The electric energy indices of air compressors operating in the Polish mining industry are given in Table 8.6, the last column showing the indices normally used for design purposes.



TABLE 8.6 Electric power indices for stationary compressors in the Polish hard-coal mines

Index	Type of compressor	Type of drive	Value	Value taken for calculations
Power utilization factor	—	synchronous (with compensation)	0.622–0.750	0.732
		synchronous	0.782–0.998	0.902
		asynchronous	0.727–0.942	0.849
Power factor $\cos \varphi$	—	asynchronous	0.71–0.954	0.846
Energy utilization index $\text{kW} \cdot \text{h}/\text{m}^3$	Centrifugal	—	0.081–0.150	0.107
	Low pressure piston type	—	0.081–1.36	0.113
	High pressure piston type	—	0.231–0.279	0.252
Unit power consumption index for transport $\frac{\text{kW} \cdot \text{h}}{\text{m}^3 \cdot \text{Pa}} \cdot 10^{-6}$	Centrifugal	—	0.123–0.259	0.166
	Low pressure piston type	—	0.138–0.231	0.183
	High pressure piston type	—	0.129–0.162	0.144

Apart from the air compressor itself the compressed air system includes:

- filters for inlet air including suction connector pipes and control gate valves
- compressed air pressure hoses, together with non-return valves
- cooling system including radiators for circulation water (in a closed cooling system).

Selection of capacity, power and number of compressors (most commonly two working plus one stand-by) is based on the compressed air balance prepared from the manufacturer's data on unit air consumption by individual machines and equipment air losses in the network.

The consumption of compressed air by air driven machines and equipment varies considerably, depending not only on the useful capacity of the machines and equipment but also to a great extent on their technical condition and efficiency. The most widely used air-driven machines and equipment are drills and air-duct fans. The unit air consumption of Polish-made air drills and fans is:

- W 22 type air drills — 0.053 m<sup>3</sup>/s
- W 27 type air drills — 0.067 m<sup>3</sup>/s
- air-duct fan 600 dia. — 0.33 m<sup>3</sup>/s
- air-duct fan 800 dia. — 0.56 m<sup>3</sup>/s.

### 8.2.2 Compressed Air Network

The pipelines and fittings in compressed air networks should be chosen to ensure the required pressure for air drives (MN/m<sup>2</sup>) at the required point.

The pressure drop  $\Delta p$  (MN/m<sup>2</sup>) between the point of air supply and consumption is calculated from the formula

$$\Delta p = p_p - p_k, \quad (8.27)$$

where:

$p_p$ —pressure at the supply point

$p_k$ —pressure at the consumption point.

For the calculation of pipe diameters an air velocity  $w \leq 15$  m/s may be assumed. At the terminal sectors of the pipeline greater velocities may be taken if they do not cause exceeding of the permissible pressure drop  $\Delta p$ .

The diameter of the pipeline is selected provisionally and later corrected from check calculations if necessary. The unit pressure drop  $H$  per 1 km of pipeline (MN m<sup>-2</sup> km<sup>-1</sup>) is taken as in:

$$H = \frac{\Delta p}{L_1}, \quad (8.28)$$

where:

$\Delta p$ —pressure drop, MN/m<sup>3</sup>

$L_1$ —length of pipeline between air supply and consumption point, km.

The terminal pressure  $p_2$  in a particular segment  $L_2$  of the pipeline is:

$$p_2 = p_1 - HL_2, \quad (8.29)$$

where:

$p_1$ —initial pressure in segment, MN/m<sup>2</sup>

$H$ —unit pressure drop, MN/m<sup>2</sup> km.

A preliminary value of pipeline diameter is determined from the nomogram (Fig. 8.10), depending on airflow rate  $V$  (Nm<sup>3</sup>/h), initial pressure  $p_1$ , final pressure  $p_2$  and unit pressure drop  $H$ . This nomogram has been constructed for isothermal airflow in the pipeline at temperature  $t = 30^\circ\text{C}$  and a coefficient of friction  $\lambda = 0.02$  using the formula

$$V = 1.68 \cdot 10^5 \sqrt{\frac{d_{in}^3 (p_1^2 - p_2^2)}{L_2 p_1^2}}, \quad (8.30)$$

where  $d_{in}$  is the inside diameter of the pipeline, m.

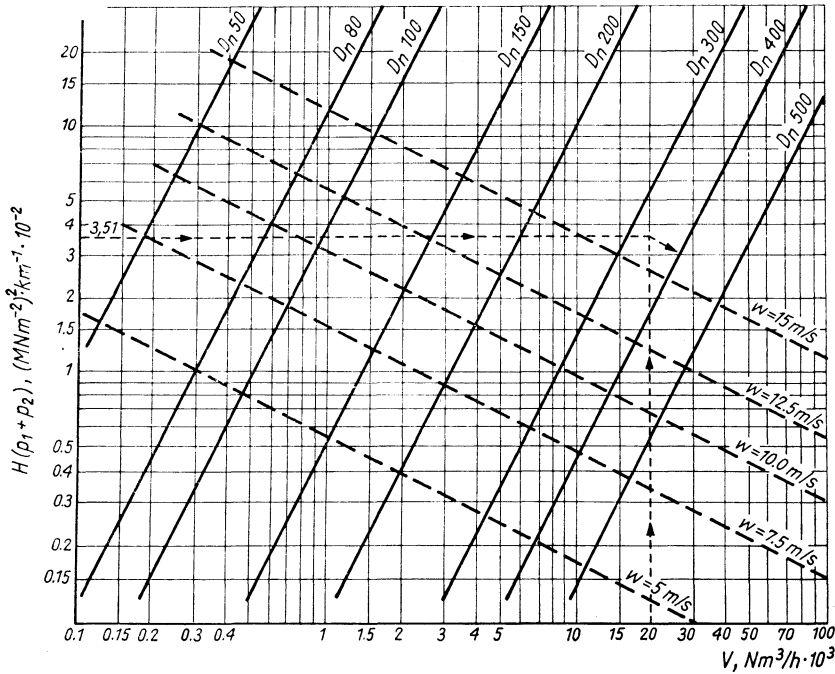

Fig. 8.10 Nomogram for calculation of compressed air pipeline diameters.

Velocities given on Fig. 8.10 are for a pressure in the pipeline of 0.5 MN/m<sup>2</sup>.

The pipeline first chosen is checked by calculation of flow resistance. The pressure losses are calculated starting from the supply point towards the receiving point. For pipelines with flanged joints the losses  $\Delta V$  due to non-airtightness should be taken into account. The losses may be roughly calculated from the formulae:

— for pipelines located in the main cross-cuts

$$\Delta V_1 = 0.8d_{in}L \tag{8.31}$$

— for district pipelines

$$\Delta V_2 = 2d_{in}L \tag{8.32}$$

where:

$d_{in}$ —pipeline inside diameter, m

$L$  —length of pipeline, km.

From check calculations changes are made, if necessary, in pipeline design diameter to keep the pipeline terminal pressure close to the assumed value.

The design should indicate the method of laying the air pipeline at the surface, starting from the compressor room right up to the shaft (in ducts on

bridges or in the ground), in the shaft, the shaft bottom and then in the cross-cuts and headings. Depending on the siting and the method of pipeline laying a suitable draining system is selected.

To secure proper distribution of compressed air, regulating fittings and control and measurement instruments must be provided, i.e.:

- flow meters, pressure and temperature gauges at the outlet points from compressor rooms with the transmission of data to the mine dispatch room
- pressure and temperature gauges at the points in the shaft where the pipeline branches off
- flow meters at the main pipeline branch points in the cross-cuts.

### 8.3 Heat Energy Management

Parallel with increased electrification there has been a decrease in the consumption of heat energy in the mines. Due to the steady advance of electrification in Poland, the consumption of heat energy in the last twenty years has dropped to about one quarter. Nevertheless, in the overall balance heat energy is still a significant item. In European countries the heat consumption index varies from 200 to 300 MJ/t net output. In Poland the average figure is 250 MJ/t.

Heat energy, of which steam or hot water is the carrier, is used mainly for the mine bath house, heating of buildings at the mine surface, warming ventilation air in downcast shafts, and occasionally for compressor and winding machine drives. In Polish climatic conditions, for space heating 120 kJ/h per 1 m<sup>3</sup> is assumed, and for warming 1 000 m<sup>3</sup>/min of air entering the downcast shaft to +2°C, about 1.66 GJ.

In Polish hard-coal mines the structure of heat consumption is as follows:

- |                                |       |
|--------------------------------|-------|
| — baths                        | — 35% |
| — heating of premises          | — 31% |
| — production of compressed air | — 11% |
| — heating of shafts            | — 10% |
| — other industrial purposes    | — 13% |

The last item includes steam for shunting locomotives and for the drying plant in the coal preparation department.

Thermal energy for the mines is usually produced in their own generating stations and is also used to heat nearby housing estates or neighbouring towns. The basic raw material for the production of heat is steam coal in the form of a mixed charge (small coal, fines, middlings).

In calculations for the design of heating installations in mine surface facilities, temperatures determined in the relevant standards are taken. Alternatively temperatures which meet technological requirements, taking into account outside temperatures and heat-transfer coefficients, are considered.

The type and parameters of the heating agent in internal heating installations are selected, bearing in mind the function of the facility premises and the parameters of the heating agent in the heating network.

The recovery of waste energy from various technological processes, e.g. production of compressed air, ventilation of baths, mine ventilation, etc., can help to balance heat requirements. Table 8.7 gives examples of waste heat utilization for practical purposes and the results of technical and economic analyses of the advantages gained. Some of these projects have been implemented in the Polish hard-coal mines.

TABLE 8.7 Utilization of waste heat for practical purposes. Results of technico-economic analyses

Source of heat recovery-scheduled utilization	Quantitative unit of heating medium	Heat recovery from unit heating medium GJ/h	Demand power MW	Saving of coal t/year	Recovery coefficient	Remarks
Heat from upcast air current for heating of downcast air	1000 m <sup>3</sup> /min	1.93	0.15	45.8	3.56	Economic without heat pump
Heat from upcast air current for space heating	1000 m <sup>3</sup> /min	0.42	0.064	8.8	2.25	With heat pump not economic
Heat from underground waters for space heating	1 m <sup>3</sup> /min	4.2	0.61	141	2.6	With heat pump non-economic in view of excessive investment costs
Heat from 0.7 MPa compressors for heating bath waters	10 000 m <sup>3</sup> /h	0.67	0.001	331	220	Highly economic

Methane is a very valuable raw material and should be utilized in the chemical industry. Only in cases where methane production is sporadic or delivery to outside consumers is not technically and economically justified may it be used to produce heat for the mine. In such cases it is combusted in coal boilers adapted for gas, or when the methane production is sporadic, in specially designed mobile boilers.

## **Chapter 9**

### **Mine Storage and Transport Management—“Transmag” System**

#### **9.1 Problems of Storage-Transport Management in the Coal Mining Industry**

Organizationally, technically and economically sound operation of hard-coal mines depends, among other things, on the regular supply of materials and technical means necessary to fulfil this function. Coal mines are large scale consumers of timber, various building materials, prefabricated concrete components, metallurgical products, electrical equipment, cables, machines, etc., and the regular delivery of these items is essential to maintain production and safe working conditions.

In normal circumstances when the system of supply of materials, machinery and spare parts functions correctly, and the distances between the mine and the producers and distributors are not great, regular supply causes no problems. All that is necessary is to provide reasonable storage facilities for minimum normative reserves of materials and spare parts required to cover current needs, without unnecessary freezing of financial resources. Storage costs are also correspondingly low. However, when there is a larger grouping of mines in a given coal mining region (for instance, in the Rybnik, Upper Silesian or currently building Lublin Mining Regions) and particularly if these mines belong to the same economic organization, it may be advantageous to plan a joint materials supply and storage system. The total storage costs can then be reduced for all the members, the level of reserve storage lowered and the total investment expenditure for construction of stores and storage yards kept low. This system can prove especially effective in the case of new mines located in newly developed mining regions, particularly when these regions are far from producers or suppliers.

In underdeveloped countries a reliable supply of materials can be difficult.

This problem has to be solved satisfactorily, otherwise it could jeopardize the continuity of mine production or even the safety of the mining crews.

Periodic disturbances in regularity of deliveries prompts individual consumers to keep reserves of materials and technical supplies in excess of current needs. This increases market difficulties, particularly as regards materials in short supply (in this case very often rationed), causing negative social-economic repercussions in the given country. Furthermore an excessively high level of stores means freezing of the funds spent on the purchase of the stored materials which are "non-productive" as long as they are in store.

When deliveries are unreliable, or materials are simply unobtainable on the market, a system of individual collection of products from the manufacturer is most often used. The transport of materials and technical supplies from the producer to the site is then very important. The goal here is both maximum utilization of transport facilities and maximum simplification of handling operations.

The ideal solution for the materials-storage system is to have the materials, equipment and machines ready for shipment from the manufacturer so that, loaded on the proper transport at the proper time, they can be delivered to the proper site at the mine at the moment when they are required. This is in practice unattainable, and in the case of underground mines, even impossible.

Every action which reduces the gap between the ideal and the actual system is valuable. Such actions should aim not only at rationalization of storage-transport management but also at reducing the labour demand and improving safety conditions, and should cover the technical facilities and transport technology as well as the organization of the operation of the system.

The scale of this problem is illustrated by two figures. To produce one million tonnes of hard coal the industry consumes about twenty thousand different items of material, with a total weight of thirty thousand tonnes in the mines and mining enterprises. It is worth noting that the greater part of the materials delivered to the mines remains in the mine workings for ever, and that only a small part is recovered for re-use. Consumption of materials increases in direct proportion to the increase in coal production; hence with rising hard-coal production the problems of materials-transport management become more acute.

In 1970 the Chief Mining Studies and Design Office in Poland evolved a concept and eventually a finalized scheme for a modern storage-transport system dealing with materials and technical supplies delivered to the mines. The system is called "Transmag" and offers a solution to the problem of storage and transportation of materials *en route* from the producer or supplier to the utilization site. Many elements of this scheme have been used in mining complexes in Poland and abroad.



## 9.2 Essence, Purpose and Model of the System

In the traditional model each mine deals individually with all problems involved in supply of materials necessary for production. Countries with a fluctuating supply market have to maintain numerous commercial contacts with producers or distributors and arrange delivery of materials to the mine stores. This calls for a large number of administrative personnel and the operation of varied transport facilities. Additional problems arise due to the different forms of materials supply which influence the technology of storage and transport of materials in the mines. In many countries the majority of basic and auxiliary materials are supplied in bulk. This necessitates laborious handling, while incorrect use of loading equipment can cause damage or destruction of the delivered goods.

Delivery should allow rational mechanization of transshipment of goods from the manufacturer to the utilization site. The "Transmag" system does just that. This is achieved by forming the materials into loading units which correspond to the specific conditions of the mine users and to transport requirements, while the organization is based on modern management systems.

The "Transmag" system consists of a collection of internally ordered "basic sets", each of which comprises several elements. A basic set in the "Transmag" system is a storage-transport "chain" for a given material or group of materials of closely similar physical properties and similar storage-transport qualities. The elements of each set are the technical means and organizational factors necessary for proper operation of this set. The basic sets include materials or groups of materials supplied to the mines in large quantities, such as mine timber props, half sawn props (standard and impregnated), sawn timber, fitches, prefabricated concrete components, lime dust for dusting of mine workings and for anti-explosion barriers, stowing cloth, stowing pipes, steel elements, yielding support arches, netting for arch support, bricks, aggregate, cement, conveyor belts, rubber articles and protective clothing, cables and conductors (power, telecommunications and signalling control), steel ropes, mining machines and equipment, etc.

Each of the basic sets should operate in three sectors of the system, i.e. in the suppliers, storage and users. This is an ideal state in which materials, formed into loading units, are delivered to the required site either at the surface or underground, after either having passed through the central stores, where they should be classed as normative spares, or being delivered directly to the mine in question. Materials delivered to the mine are reloaded on to suitable transport and dispatched to the working site. When the suppliers cannot be fitted into this system, i.e. the materials and machines cannot be made to

comply with the specific shape and dimensions requirements for loading units, they are dispatched to the required central stores of the mine complex and here they are formed into suitable loading units.

When considering the “Transmag” system in its full form (i.e. jointly with the suppliers of materials) it may be seen that it includes the travel routes of materials and equipment from the place of purchase or manufacture via storage and transport to the place of utilization, mainly underground in the mine as shown on Fig. 9.1.

The role of supplier for a group of mines is taken by the branch or multi-branch stores. Materials from the first sector of operation of the “Transmag” system are ordered and brought in by the second sector and dispatched in the required quantities at the required time for use by the third sector. Consequently, the organization of supply to the mines is in the hands of specialized units (sector two) which have a double duty, i.e. to implement the summary orders received from the mines located in their area of operation, store the goods delivered and dispatch them to the mines at the time and in quantities as ordered. In justified cases the goods may be delivered directly from the manufacturer to the consumer, bypassing the central stores.

The “Transmag” system provides a complex solution to the problems of materials transport management, offering technical and economic advantages by reducing the labour demand (particularly for materials handling), the

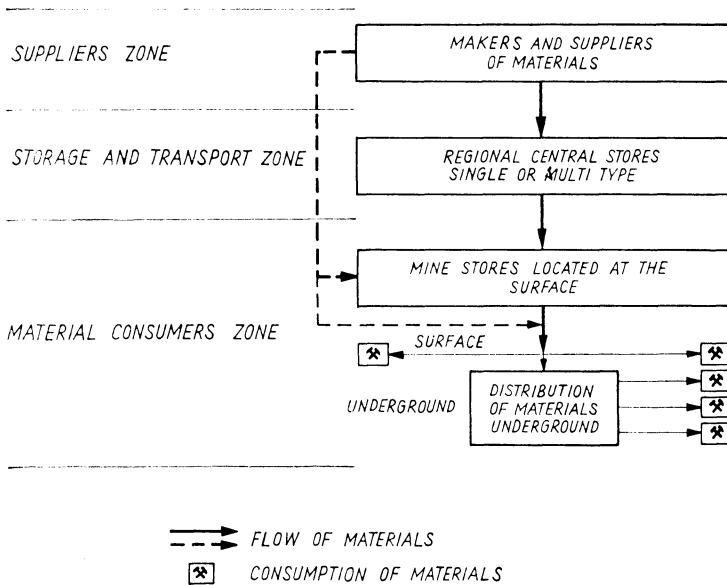

Fig. 9.1 Flow of materials in the “Transmag” system.

damage and destruction of goods and the level of stores reserves. Suitable technical facilities are provided, including equipment for forming the loading units, handling of materials, transport and storage and also for distribution of these materials in the mines.

In its organizational methods the “Transmag” system foresees a wide application of computer techniques and incorporation of materials management methods into the management data system of the mine or group of mines.

Figure 9.2 gives a schematic diagram of the “Transmag” system illustrating the essence of this system and its model.

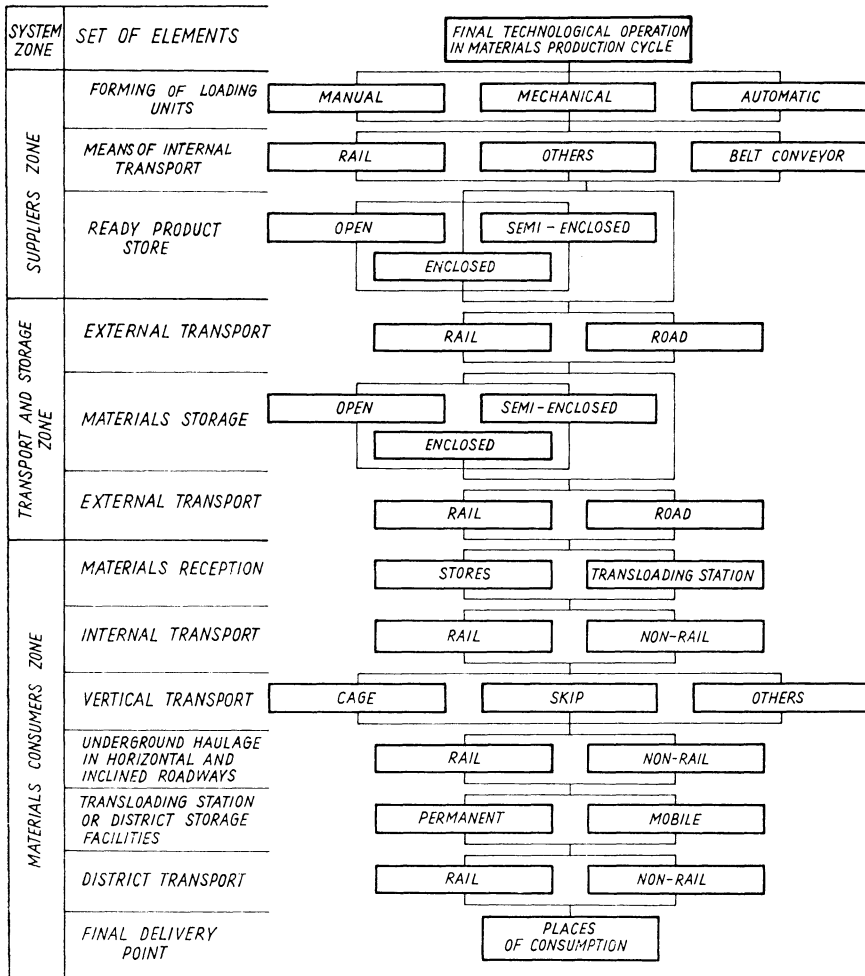

Fig. 9.2 “Transmag” system schematic diagram.

### 9.3 Basic Set of the System and its Elements

As already explained, the “Transmag” system represents a collection of basic sets each with several elements. Each set is internally ordered and covers a material or group of materials of similar properties. The basic set is a process taking place through all three sectors of system operation (Fig. 9.1) and its elements are the technical means and organizational factors to be found at each point of this process. The logical connection between the individual elements defines a specific order in the set and maintaining this order ensures successful realization of the set.

Appropriate collections of elements occurring on individual sections of the materials route are subordinated to individual sectors of system operation. These elements are the means and methods for forming the materials into loading units for transport, loading and unloading. Depending on the conditions in which the set is implemented, the materials route may be different, but it always passes through the collection of elements as shown in the diagram corresponding to the given sector of system operation. Individual sets differ both in the object of the process (type of materials) and the composition of individual collections of elements.

The common element in each basic set is the loading unit. It is always the same quantity of the given materials packed together for the duration of transport and storage in such a way as to allow mechanical handling and to provide protection against damage due to transport and storage, atmospheric conditions or the mining environment.

The formation of a loading unit should be the last technological operation in the production process in the manufacturer’s sector. The loading units then form the initial items in the basic sets of the “Transmag” system. If it is impossible to comprehend all suppliers of materials and products in the “Transmag” system, then the formation of loading units has to be moved to the second sector, i.e. to the central store of a group of mines.

Loading units are divided into two basic groups:

- natural loading units
- formed loading units.

Natural loading units include all materials or products whose structure, weight and overall dimensions, exceed (where disassembly is not feasible) the following parameters:

- weight over 1 250 kg gross
- overall dimensions in the vertical cross-section  $800 \times 1\,000$  mm
- width in horizontal projection 800 mm.

Formed loading units are those whose ultimate form is the result of packing a number of individual items in a single package for transport and storage purposes.

Natural loading units are principally heavy components of machinery and equipment of large overall dimensions whose disassembly is either impossible or for technical or economic reasons inadvisable. The most commonly used formed units are packages or pallets, or containers.

Packages (packet units) are usually formed from long elements. In the "Transmag" system the width should not exceed 800 mm, height 1 000 mm and length depends on the packed material. Packages are bound with steel, plastic or webbing bands or with clamps and these items are classed as non-returnable. If it is necessary to use distance members to raise the unit above floor level, these members (chocks) should ensure at least 100 mm clearance. Maximum weight of the package should not exceed 1 250 kg.

Pallets (pallet units) are formed from small size elements. The standard pallet has dimensions  $800 \times 1\,200$  mm in the horizontal projection. The "Transmag" system prefers a flat wooden pallet, single panel with access from four sides. Method of fastening depends on the type of materials transported. For small items, containers of sizes that are sub-multiples of pallet size are used. For larger items pallet frames are used. Large items (but not longer than 1 200 mm) are fastened with bands and formed into packages. Pallets of different construction are also used but always with the same horizontal dimensions, e.g. box, netting and column pallets. Pallets are returnable.

The basic dimensions of pallet units for the mining industry are: length 1 200 mm, width 800 mm, height 1 000 mm, maximum weight 1 250 kg gross.

Container loading units are formed in packages which are sub-multiples of the size of standard containers for long distance transport (railway, truck, inland water and sea transport) and have a capacity not less than  $1\text{ m}^3$ .

For specific materials the loading unit should always be of the same dimensions, irrespective of where the unit is formed and what it is made of, i.e. a standard design specified in the documentation. This documentation consists of a catalogue card and a load-calculation card prepared jointly for the same loading unit. Altogether these cards specify full characteristics of the loading unit and should be prepared before physical formation of the unit and its checking in a trial run.

The Chief Mining Studies and Design Office in Katowice prepared the documentation for 1 500 loading units, presented in the form of a catalogue. This should help in the organization of transport and storage of materials.

9.4 Planning the Technological Process of the System

All elements occurring in the three sectors of the “Transmag” system should be covered to ensure their simultaneous operation. The loading unit involved and the outline diagram of the basic set are taken as the basic data.

Conditions prevailing in the different sectors of the process and the demand for the given materials govern the form of delivery, the various technological operations required in the process and the place where such operations are to take place.

The aim should be the maximum utilization of existing facilities (stores, yards, means of transport, etc.) and exploitation of all possible modernization. New elements should be introduced only when absolutely essential.

The design of a basic set comprehends both the technology of formation

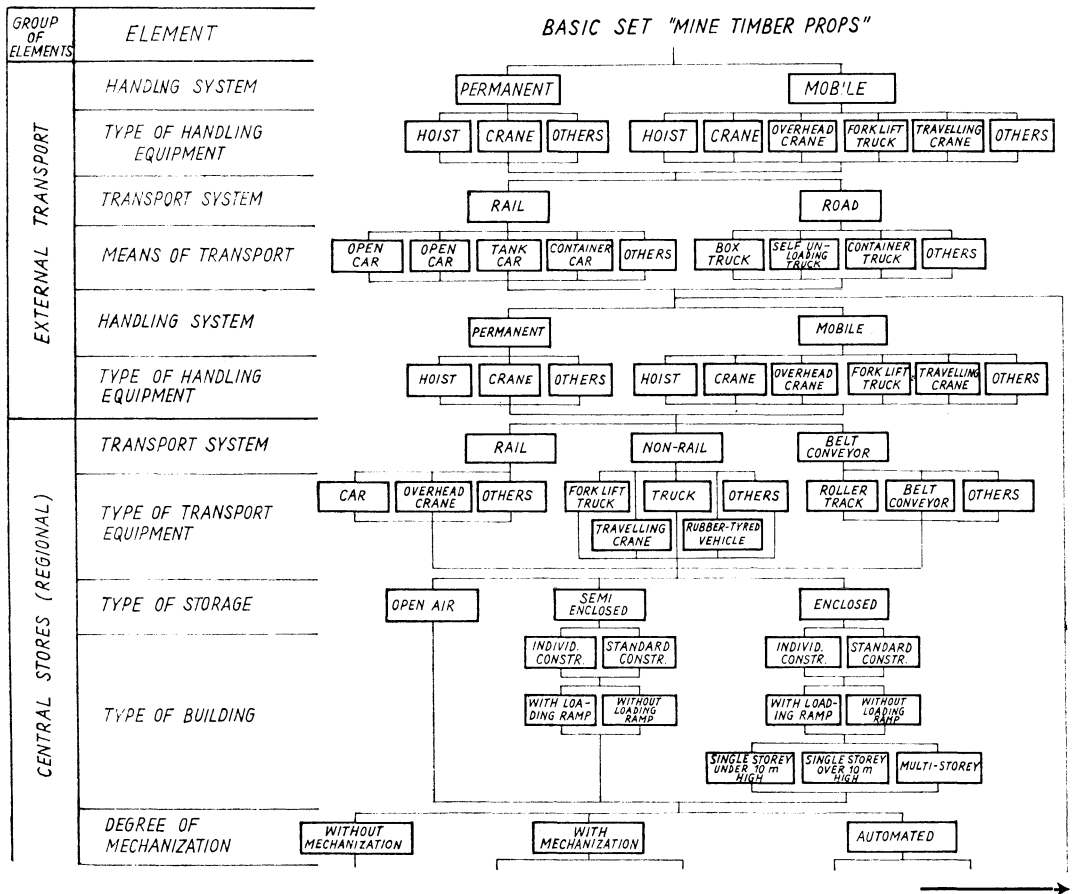

of loading units and their transport and storage. It requires a complex design based on the technological principles and including the following sections: constructional, mechanical, electrical, water-sewage and fire-fighting and costing-financial. All investors must participate in this plan. Its scope is determined by existing and future needs. Conceptual schemes and investigations, analyses and studies should be prepared beforehand.

The design of a basic set has to include all operations and take into account all the technical means encountered along the route taken by the materials and must specify the means for individual sectors of the technological process, for both the transport and storage of a given group of materials or goods.

A previously prepared "systematic order of elements and sets", similar to that shown on Fig. 9.3, may be of help in the design of basic sets. The

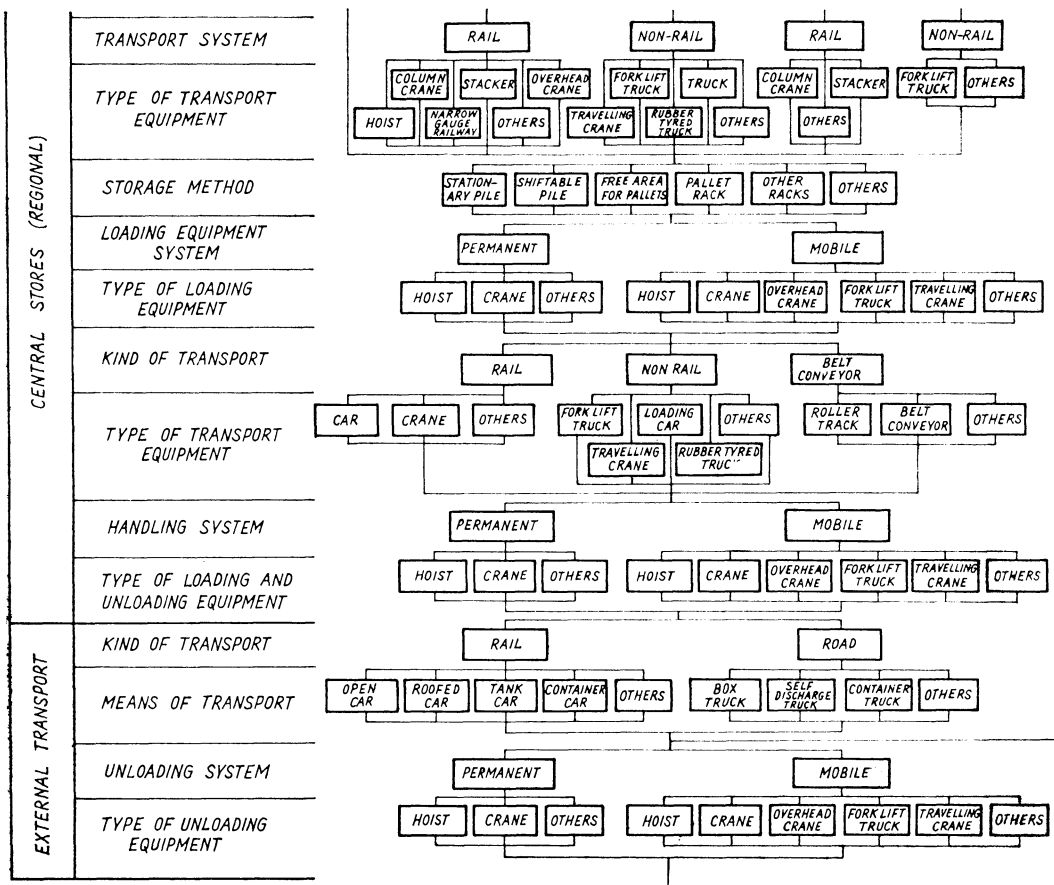

Fig. 9.3 Scheme of transport and storage elements in "Transmag" system. Basic set "mine timber props".

example of Fig. 9.3 refers to the second sector of the operation of the system (regional central store) for the basic set “mine timber props”. Similar one-line diagrams for the elements of basic sets are prepared for the suppliers’ and consumers’ sectors of the same basic set “mine timber props”. The diagram of suppliers’ sector must deal primarily with the elements of forming the loading units. Similar diagrams are made for individual basic sets (e.g. bricks, prefabricated components, yielding support arches, etc.).

Each basic set begins with the formation of a loading unit; hence the “Transmag” system starts by determining the place and method of formation of loading units of the individual basic sets. Hence for each type of materials or goods the design must envisage a loading point or station for forming loading units, specifying method of loading on to the internal transport facilities, and means and methods of storing and dispatching the prepared units. This forms a collection of elements which should ensure satisfactory operation of the “Transmag” system in its first sector, i.e. at the manufacturers. It is necessary to design or select stations for forming loading units and their equipment, handling, transport and storage facilities. Loading units may be formed by hand, mechanically or automatically. Figures 9.4 to 9.6 give a few examples of loading stations’ equipment as listed in the catalogue of equipment recommended for use in the technological process of the “Transmag” system.

Elements for the storage and transport sector are more differentiated, due to the larger number of operations. Many different types of loading units have to be handled. Furthermore, this sector has a wider scope than the producers, since it combines both the storage and transport functions. The main function is to store materials scheduled for the mines grouped in the given supply region.

Organizing the central supply and storage system for a group of existing mines takes place in several stages. In the first stage the demand for materials from the individual mines is evaluated. Decisions are made on whether materials

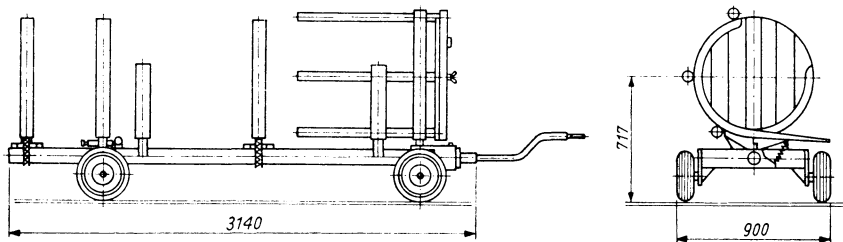

Fig. 9.4 Mobile station for formation of timber prop units.



will be stored in mines' stores and if so which and in what quantities. The demand for the whole group of mines covered by the joint materials-storage system is then determined and the size of normative reserves to be kept in the central regional stores decided.

This again governs the type, the number and the size of the central stores. With the availability of the central stores the previous supply and storage arrangements in the individual mines are gradually phased out and adapted to the centralized economy.

When constructing mines in a non-developed region, requirements are evaluated as already described. A centralized supply and materials-storage management system must be organized and ready to serve the mines from the moment of their commissioning. The system must be operational in advance of mine commissioning date. Investment for this purpose should be implemented in stages, corresponding to the growing quantities (not numbers) of materials to be stored in the storage facilities.

In selecting the equipment for the storage facilities the precise relationship between the storage and transport duties must result in their coordination. Each centralized store should operate a two-way transport system, i.e. supplier-stores and stores-mine, and of course the indispensable internal transport system. Only this type of arrangement can ensure satisfactory supply of materials to the mines and efficient operation of the stores themselves. This

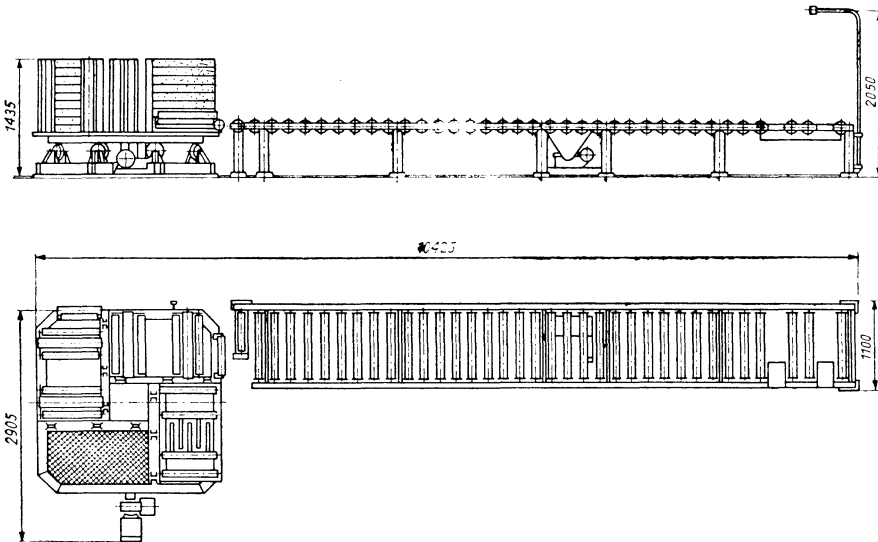

Fig. 9.5 Station for formation of transport units from prefabricated concrete elements.

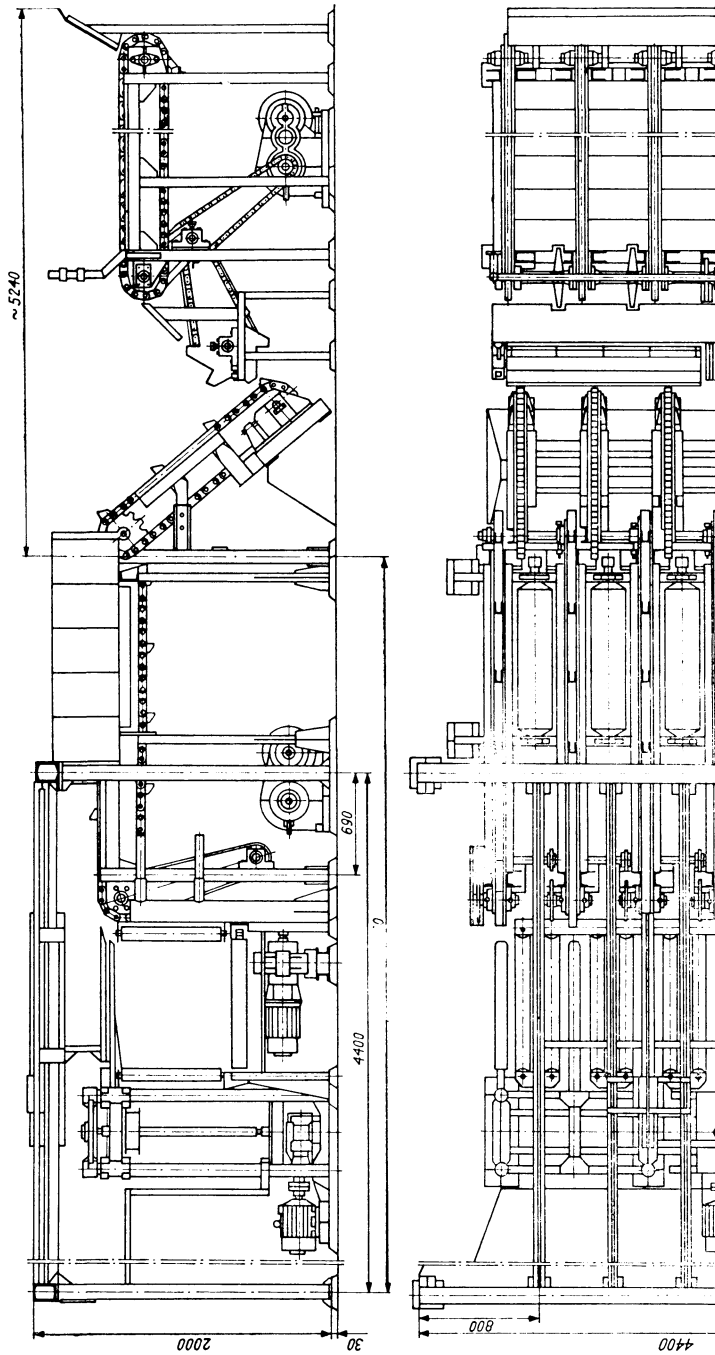

Fig. 9.6 Mechanism for forming of loading units from narrow gauge rail sleepers.

must be taken into consideration when selecting equipment for storage-transportation operations in the second sector of the "Transmag" system, which must be suitable for three basic types of storage facilities, that is:

- enclosed stores (buildings), which must have a storage height of at least 6 m and storage are not less than 1000 m<sup>2</sup> (these criteria also apply to existing buildings scheduled to be adapted as central stores)
- semi-enclosed stores, i.e. open-sided stores and fenced enclosures
- open stores (storage yards).

All these facilities must have an easy access to the communications network (roads, railway lines). Figures 9.7 and 9.8 illustrate Polish schemes for the design of central stores.

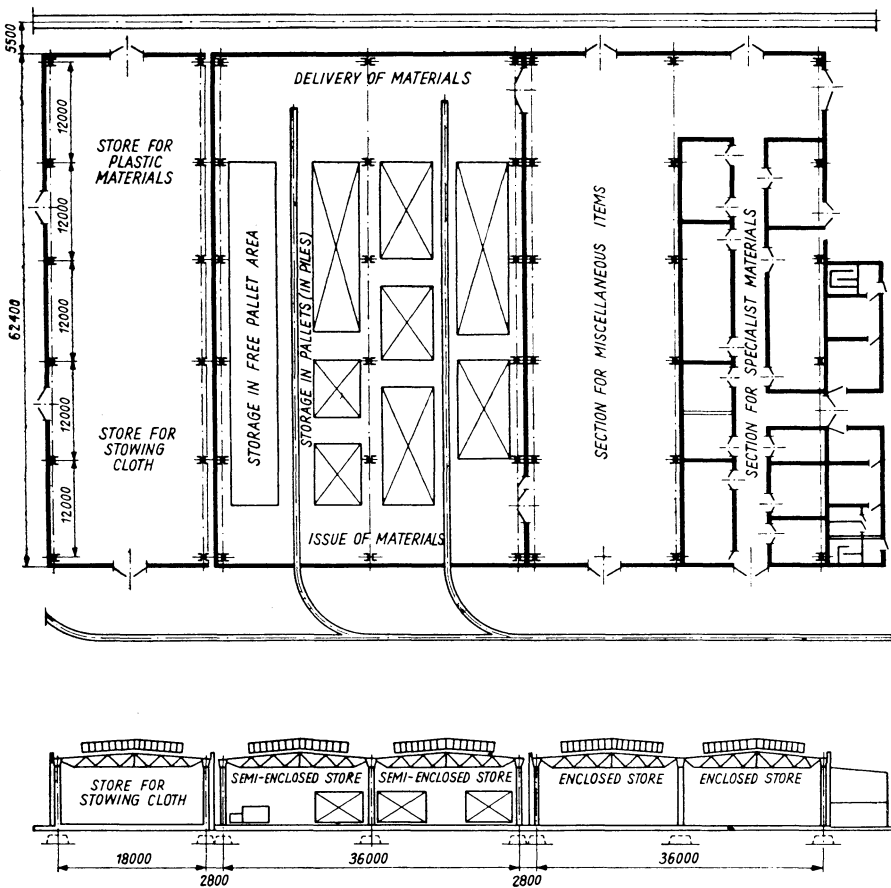

Fig. 9.7 Store. Enclosed and semi-enclosed type.

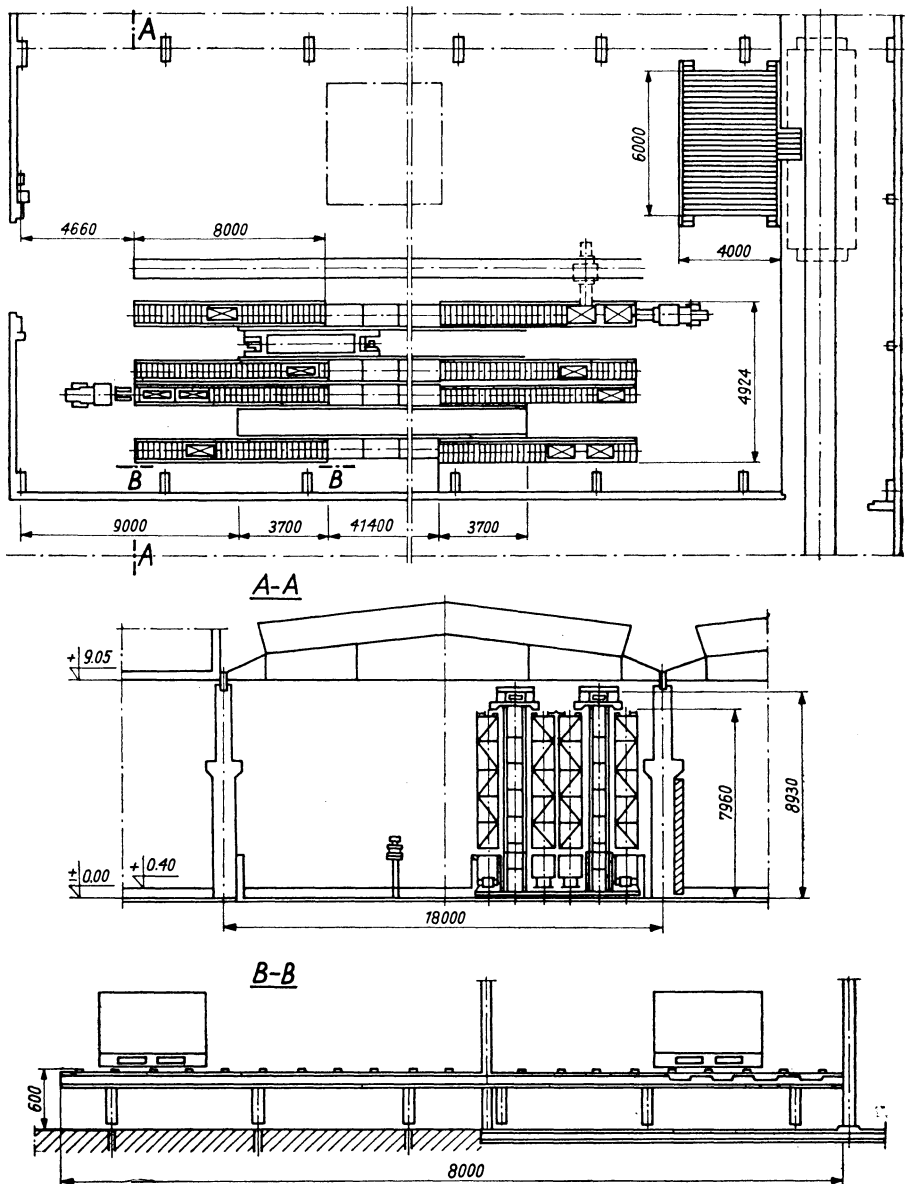

Fig. 9.8 High storage racks with stacking machine.

In the mines, i.e. the third sector of operation of the "Transmag" system, each basic set of this system ends. In existing mines, mainly due to their different transport conditions, selection of elements for this system represents the most difficult stage in the design. This makes it imperative to carry out

a particularly careful analysis of existing and new facilities and technical equipment so that the requirements of the projected centralized materials-storage management are met. For new mines the design of storage and transportation elements poses no special problems. In both cases (i.e. existing and newly constructed mines), the type and the range of needs must be determined as regards the following elements:

- handling and transport of materials and goods at the surface
- transport of materials and goods via the shafts
- transport and handling of materials and goods underground.

Materials delivered to the mine by external transport are reloaded in the mine stores which act as a handling point. This involves the transfer from external transport to the mine transport system or storage of goods in normative quantities as required for a few days or up to two weeks. The mine reloading point should have a capacity corresponding to the quantity of materials required underground during 24 hours. This capacity forms the basis for the selection of storage-reloading-transport elements. In existing mines, analysis of the feasibility of increasing the shaft hoisting capacity should determine the choice of elements for shaft transport of materials and products. This analysis should specify the modernization needs and the necessary means. The balance between the throughput capacity of the shaft and shaftside facilities and that of the handling point at this shaft is essential. In new mines the design ensures that handling and hoisting capacity are appropriate to the needs of materials transport.

Proper planning of transport and reloading of materials underground in the mine is very important.

To achieve this requires:

- detailed delineation of transport routes
- determination of quantity of materials to be transported to the particular working sites
- specifying quantity and type of equipment needed to deliver materials to the required sites in a quantity and at a time determined by the norms for the given job.

When selecting equipment for materials transport in the mine it is useful to work out a transport flow sheet. Figure 9.9 gives an example.

The introduction of the “Transmag” system brings the following useful effects:

- elimination of manual work by mechanization of loading and unloading operations
- introduction of modern forms of materials economy data recording and flow

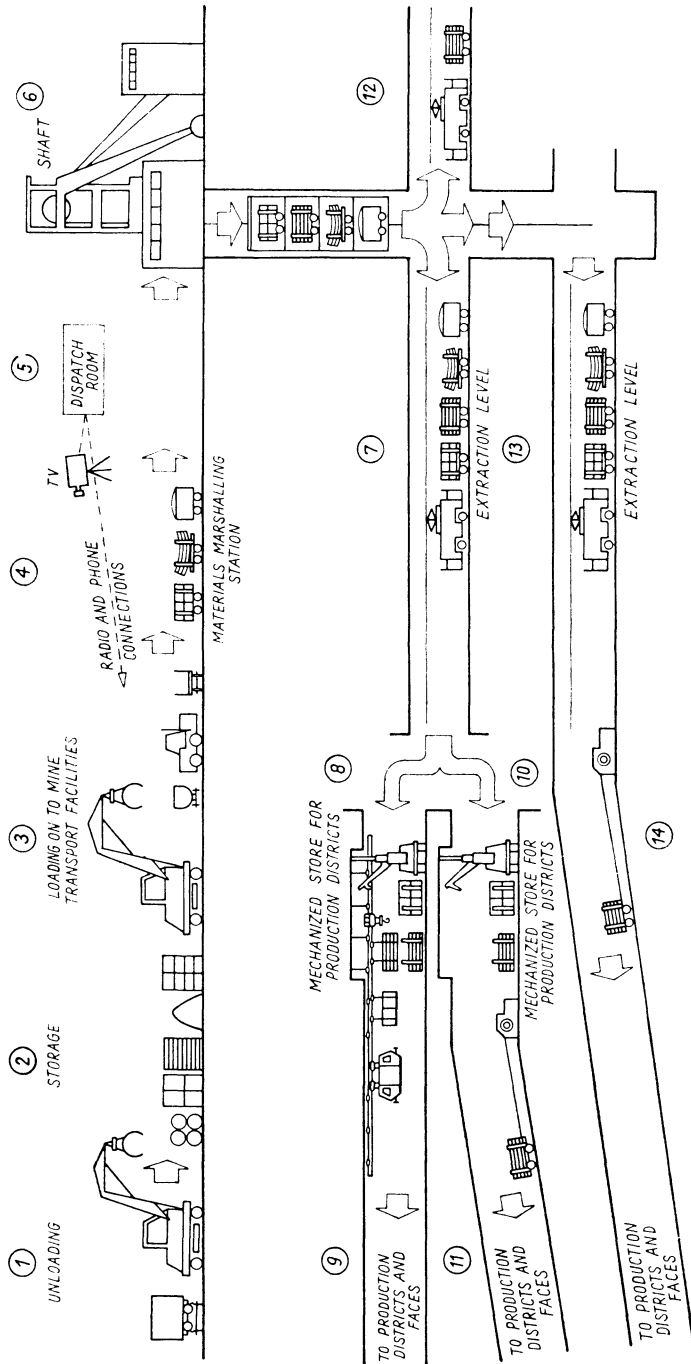

Fig. 9.9 Flow of materials in the mine.

- reduction in standard reserves and decrease in prime costs in mines operating with the centralized materials-storage system
- improvement of work safety for personnel employed in materials handling at all stations of the materials transport-storage system both at the surface and underground
- decrease in materials losses
- substantial economies due to the introduction of returnable packings.

Finally, it may be added that the introduction of computers in the Polish coal mining industry has helped to solve a number of organizational problems relating to materials economy. Several data systems for management of materials economy in the industry have been developed and implemented, resulting in significant economies.

## **Chapter 10**

### **Economic Problems in Mining Investment**

#### **10.1 Calculation of Economic Effectiveness in the Design Stage**

To create new production capacity in the coal mining industry requires considerable financial outlays. This is particularly true in the construction of new mines where the necessary expenditure has reached such proportions that the provision of adequate investment funds has become a major problem not only for individual investors but also, in the case of countries with a nationalized coal industry, for the whole national economy. This high level of investment makes it imperative to exercise the greatest care to ensure optimum planning of expenditure.

The investment project should be planned and expenditure of investment funds so designed that implementation of this investment and exploitation of the deposit gives specific economic benefits. This means the return of investment capital and profitability of the exploitation processes. Only if project design decisions and investment decisions are based on objective and thorough economic analysis can this be achieved.

Design decisions establishing values of basic mine parameters have a governing influence on the level of profitability attained. Hence the design of a new mine or the reconstruction of an existing mine is as much an economic as a technical task. All technical and technological problems should be evaluated equally from the economic aspect, which should produce solutions ensuring maximum profitability.

The economic justification of every investment project in the coal mining industry undertaken to create new production potentials involves two principal objectives:

- justification of benefits accruing due to investment implementation
- assessment of relative economic effectiveness of feasible projects, and an



accurate evaluation of the economic effectiveness achieved with the chosen design solution.

The decision to undertake an investment project is governed by the necessity of modernizing or reconstructing operating mines or by the advantage of creating new production potential (construction of new mines), in line with the development program laid down for the mining sector and based on predictions of market demand for hard coal (domestic and foreign).

This decision may also be taken for other motives, e.g. for overriding economic or social reasons resulting from the economic needs or social policy of the country concerned, as mentioned in Section 4.4.

The profitability of the investment depends primarily on design decisions establishing the values of the basic parameters of the mine. The most important decisions are:

- size of the mine, that is, its production capacity, the extent of mine concession area and mine service life
- model of the mine, i.e. the number of shafts, their siting, the number of extraction levels, and the system of horizontal development
- technical equipment of the mine.

Securing maximum profitability of the planned investment means determining optimum values of the basic parameters while at the same time satisfying all the limiting conditions imposed.

An essential condition is the ability to foresee the economic results of the decisions taken during the design process. Full evaluation of the economic effectiveness of a given investment has to be based on fully objective calculations in a complex concept.

As previously described, several variants of an investment undertaking are prepared at the conceptual stage of the design, and one of these is selected for further elaborations. The variants usually differ in magnitude of investment expenditure, in effects expected to be achieved and in their time schedule. Relative evaluation allows the selection of the most favourable variant. Absolute evaluation should indicate anticipated profitability of the investment in the context of anticipated effects.

## **10.2 Parameters Governing Investment Profitability**

It has been stated that the profitability is fundamentally influenced by the design decisions as to the size, model and equipment of the mine. Profitability also depends on the following factors:

- natural state of the deposit which influences the mine production capacity and the level of extraction costs

- conditions under which the investment is implemented, which influence the size of investment expenditure and the length of the investment cycle
- situation on the coal market and the general economic climate, which is reflected in the selling price of coal and the bank interest rates for investment credits.

When speaking of the natural state of the deposit as an essential factor governing profitability of the planned investment, it means not only the deposit itself, its nature, specific features and deposition of strata (as described in Chapter 2), but also the overlying strata. The type and characteristics of the overburden markedly influence mining investment costs. Overburden parameters determine the siting of shafts and establishing the first ventilation level. Quicksand formations are often found in the overburden and this is very important when selecting shaft sinking method. The cost of shaft sinking by special methods (e.g. freezing of strata) is 2–3 times greater than when using conventional methods and the time required is longer. The type of strata occurring in the overburden, particularly close to the surface, largely influences conditions for construction of surface facilities. The building of heavy structures such as the coal preparation plant and headframes depends on the characteristics of the overburden as far down as 30 metres.

The thickness and natural conditions of the overburden may also influence decisions on the depth of mine levels. High temperatures and increased strata pressures are found at greater depth, causing increased investment expenditure, larger costs for support of workings, underground air conditioning, etc.

The most important factors governing the profitability of mining investment are discussed here in greater detail.

### *10.2.1 Production Capacity of the Mine*

Production capacity of the mine decides the values of all the unit parameters (per tonne of coal produced). This capacity depends on deposit resources and mining-geological conditions. The mine concession area determines the level of mineable resources. Mine daily production is limited by the minimum service life of the mine. It has been estimated that the service life of a projected deep hard-coal mine should be not less than 50 years. Production capacity of the mine is also limited by the mining and geological conditions, particularly by the methane content, the thickness of seams and their inclination, disturbances in seams deposition and consequent difficulty in developing the extraction front and also the planned extraction depth. An increase in the planned production capacity of the mine necessitates an increase in the investment expenditure.

In general, it may be said that with a firm selling price for coal, an increased output gives an increased value of mine production while unit extraction costs normally drop.

For a given deposit and a fixed selling price for the coal there is a definite optimum size of production which if exceeded results in lowered profitability, because the necessary increase in the investment expenditure is not compensated by a rise in the value of production.

### *10.2.2 Cost of Coal Winning*

Coal winning costs depend mainly on the mining and geological conditions of the deposit, on the productivity possible in such conditions, and on the mine production capacity. Prime production costs consist of labour costs, energy, materials and depreciation. The share of the individual sectors in total production costs differs from country to country. In the Polish mining industry the share of labour costs is about 50% and materials about 20% of total prime costs.

When carrying out technical and economic analyses and estimating the profitability of the investment project at the design stage it is necessary to calculate future coal extraction costs. This is relatively difficult since the whole production process in the mine must be considered in the context of the deposit mining and geological conditions. Use may be made of statistical data from mines with the same or similar mining, geological and technological conditions.

### *10.2.3 Investment Expenditure*

The magnitude of investment expenditure naturally has a fundamental influence on investment profitability. Investment costs are determined primarily by the scope of mining work in the deposit plus construction<sup>v</sup> and installation work both at the surface and in the underground workings.

Different countries have various criteria for deciding whether or not expenditure may be classed as investment costs. Investment costs are usually taken to include the value of all investment work and services handed over to the investor, installed machinery and equipment and machines which do not require installation, transport means, tools, non-durable items and materials issued to the construction site from the investment stores and remaining outlays.

Depending on the type of effects produced the costs of individual investment tasks may be divided into four groups:

- investment costs which increase the value of fixed assets
- investment costs which increase the value of working assets

- investment costs which increase non-material and legal values
- investment costs giving no economic effects (assets).

The items which increase the fixed assets are all working facilities and durable objects. These include main workings, buildings, structures, machines, equipment and apparatus, transport means. The costs of these items acquired as a result of the investment activity comprise direct and indirect costs. The direct costs are associated with the construction or the purchase of fixed assets (e.g. shaft sinking, the coal preparation plant, purchase of machinery, etc.). The indirect costs consist primarily of the costs of the individual investment documentation, outlays for the purchase and adaptation of standard documentation together with costs of author's supervision, costs of geological and geophysical surveying, geodetic measurements plus the costs of construction and dismantling of temporary facilities and equipment at the construction site.

The items which increase the working assets also include the so-called *first equipping of investment facilities*, i.e. tools, measurement and testing instruments. The cost of purchase of such items is included in the investment expenditure only if it is specified in the approved design-costs documentation for the given investment project.

Some costs connected with the preparation and the actual implementation of investment and also with the preparation for the future production work in the newly constructed and modernized facility, and costs of author's supervision, are included in the investment costs increasing non-material and legal values.

Investment costs giving no economic effects (assets) include the interest paid on investment credits, and the cost of protection and maintenance when an investment project has been temporarily or permanently discontinued.

To evaluate investment effectiveness at the conceptual design stage it is necessary to have a model of the distribution of investment expenditure in the consecutive years of investment implementation. Actual distributions of expenditure for planned or already completed investment undertakings form the basis for developing this model.

Of the various attempts to work out a model of distribution of investment expenditure the following are distinguished:

- a model assuming sinusoidal distribution of investment expenditure as in the formula

$$i(t) = \sin\left(\pi \frac{t}{b}\right), \quad (10.1)$$

— a model based on linear distribution of expenditure during the mine construction time, i.e.  
for the period 0– $a$

$$i_1(t) = \frac{2}{aw} t, \quad (10.2)$$

for the period  $a$ – $b$

$$i_2(t) = \frac{2}{bw} t + \frac{2}{w}, \quad (10.3)$$

— a model described as:  
for the period 0– $a$

$$i_1(t) = \frac{w}{a} t^2, \quad (10.4)$$

for the period  $a$ – $b$

$$i_2(t) = -t^2 + bt, \quad (10.5)$$

where:

$i(t)$ —share of the investment expenditure in the year  $t$  relative to total expenditure, %

$b$ —mine construction period, years

$a$ —mine construction period up to the time of the first production, years

$w$ —period of the production development, years.

Comparative analysis of these models proved that the model given by formulae (10.4) and (10.5) most accurately describes the real distribution of expenditure.

#### 10.2.4 Mine Construction Cycle

The mine construction cycle covers the period from the date of handing over the construction site to the contractor up to the date when the investor takes possession of the completed investment and normal operation may be started up after technological commissioning. The length of the construction cycle should be specified in the investment design and agreed in detail between the investor and subcontractor. In countries where the government acts directly or indirectly as the investor and also provides the necessary funds, construction cycles are fixed by the relevant regulations. For instance in Poland, the Ministry of Construction and Building Materials publishes periodically the norms for investment cycles, specifying time limits which must be adhered to. Most of the mines designed and constructed in the last ten years have been, or are

being constructed in the so-called *directive cycle*, i.e. a shorter investment cycle than the normative. Table 10.1 gives examples of normative and directive construction cycles for several Polish hard-coal mines.

TABLE 10.1 Standard and directive construction cycles for some Polish hard-coal mines

Mine	Target production t/day	Construction cycle, years	
		standard cycle*	directive cycle*
"Manifest Lipcowy"	12 000	8/14	7/13
"Borynia"	10 000	10/15	9/14
"XXX-lecia PRL"	15 000	7/13	5/11
"ZMP"	8 000	6.5/9.5	5/7.5
"Piast"	24 000	6/11	4.5/9.5
"Czeczott"	24 000	7/11.5	6.5/11

Note:\* Number in numerator indicates construction time to first production. Number in denominator—total construction time.

The length of the investment cycle also directly influences investment profitability. A shortened construction cycle means a shorter period when capital is locked up, and an earlier start to production. This problem has been dealt with in Chapter 5. One of the large Polish coal mines with a methane hazard (15 000 tonnes per day of coking coal) may be cited as an example. By shortening the construction cycle from 13 to 11 years an increase of 20% in investment effectiveness index was achieved.

It should be added that mine construction time is markedly influenced by the time required for mining excavation work. A good example is the "Kaczyce" mine in Poland, where five years of the six-year construction period (up to winning the first coal) were needed for shaft sinking and development work at the various levels. Naturally, other mine investment facilities were constructed simultaneously.

### 10.2.5 Coal Selling Price

This depends on the quality of the coal extracted and its degree of preparation which determines the value of production, and hence investment profitability. Unfortunately, coal prices are not constant but are dictated by the demand and supply, and frequently other factors as well. During the last forty years, for example, large fluctuations in coal prices have been noted. In view of the long time elapsing between deciding on the mine construction and the moment when normal production is achieved, it is virtually impossible to predict the future selling price of coal with any accuracy. This represents a basic difficulty in evaluating the profitability of an investment undertaking.

### 10.2.6 Interest Rate

The value of calculation rate of interest on capital laid out for investment implementation is essential in assessing the profitability of mining investment projects. The larger the capital outlay and the longer the construction time, the greater is the importance of the interest rate. The proportion of these funds laid out in consecutive years of mine construction also plays a large part. In some countries the rate of interest is regulated by laws. For example, in Poland the rate of interest on investment capital is fixed centrally at 8%, but for certain sectors of industry this may be less, in the hard-coal mining industry it is 3%.

In conditions of market economy the normative rate of interest does not apply and for assessing the investment an interest rate equal to the minimum accepted capital return rate is normally assumed. This signifies the minimum profitability anticipated due to investing the available capital and its value is equal to the "purchase" of the capital by the investor, allowing 1–2% for the risk margin.

## 10.3 Calculation of Economic Effectiveness of Investment

In Section 4.4, when discussing the technical and economic assessment of mine reconstruction variants it was mentioned that there are many methods and criteria of economic analysis applied in different countries for assessing reconstruction designs. This applies in exactly the same way to the economic analysis of construction variants for new mines or other investment undertakings. In Chapter 4 the method used in Poland to evaluate the investment effectiveness of mine reconstruction was given. Formulae (4.1) and (4.2) with additional explanations and principles for determining particular values required to calculate the index of investment effectiveness are relevant.

The same principles apply when considering the construction of a new mine or other investment project (e.g. building a new central coal-preparation plant). Calculation of the economic effectiveness involves comparing necessary investment expenditure for mine construction with the effects anticipated from exploitation of the deposit. The comparison may be made as a balance of expenses and returns giving the effectiveness index  $E$  in a differential form ( $E_r$ ). The comparison may also be in a relative form, i.e. the effects are set against the capital expenditure, giving the effectiveness index in a quotient form ( $E_i$ ). The minimum condition of effectiveness is met when:

- for the differential form, the effectiveness index  $E_r$  is not negative ( $E_r \geq 0$ )
- for quotient form, the effectiveness index  $E_i$  is not less than 1 ( $E_i \geq 1$ ).

As it is necessary to perform effectiveness calculations at various stages of the design process, two formulae for the calculation of effectiveness index  $E$  are used, simplified and developed. The simplified formula, which neglects the time factor, is used to evaluate investment effectiveness at the conceptual design stage. The developed formula is used at the stage of preliminary design, when the data available is sufficiently detailed. The index of economic effectiveness according to the simplified formula is:

$$E_u = \frac{P - k}{I(1 + br/2)(r + S) + Br}, \quad (10.6)$$

where:

$P$ —expected value of yearly production

$k$ —expected cost of yearly production

$I$ —nominal investment outlay for mine construction

$b$ —mine construction period, years

$r$ —rate of interest, %/100

$S$ —average rate of depreciation of fixed assets, %/100

$B$ —funds to form a reserve of working assets.

Index  $E_u$  is a measure of the effectiveness of expenditure of capital funds to obtain annual production, while the yearly profit  $P - k$  (neglecting depreciation) is quoted relative to the investment expenditure together with the amount of capital locked up.

The index of economic effectiveness according to the developed formula, in quotient form, is

$$E_i = \frac{\sum_{t=1}^m (P_t - K_t)(1 + r)^{-t}}{\sum_{t=0}^m N_t(1 + r)^{-t}}, \quad (10.7)$$

where:

$m$ —calculation period, years

$P_t, K_t$ —value of annual production ( $P_t$ ) and of annual running costs ( $K_t$ ) in  $t$  consecutive years of investment implementation and exploitation

$N_t$ —value of capital expenditure in  $t$  consecutive years of investment implementation and exploitation.

Index  $E_i$  has the same meaning as index  $E_u$  in formula (10.6) except that it takes into account the time factor in the form of updating calculations.

The index of economic effectiveness of investment according to the developed formula, in differential form, is:



$$E_r = \sum_{t=0}^m (P_t - K_t - N_t) (1+r)^{-t}. \tag{10.8}$$

This index balances the returns  $P_t$  and outgoings  $K_t$ , as well as the capital expenditure  $N_t$  in the assumed calculation period. It indicates the factual value of profit made in the calculation period due to the investment implementation and exploitation.

Economic effectiveness of mining investment is often evaluated on the basis of the capital value of investment, the internal rate of investment and the yearly repayment.

The capital value of investment determines the sum of currently updated expenses and returns during project implementation and exploitation, assuming a specific value of interest rate. The updating of annual expenses and returns is usually related to the moment of commencing investment implementation. Figure 10.1 shows the yearly investment expenditure  $N_t$ , value of production  $P_t$ , production costs  $K_t$  and value of profit  $Z$  in  $t$  consecutive years of mine construction and exploitation.

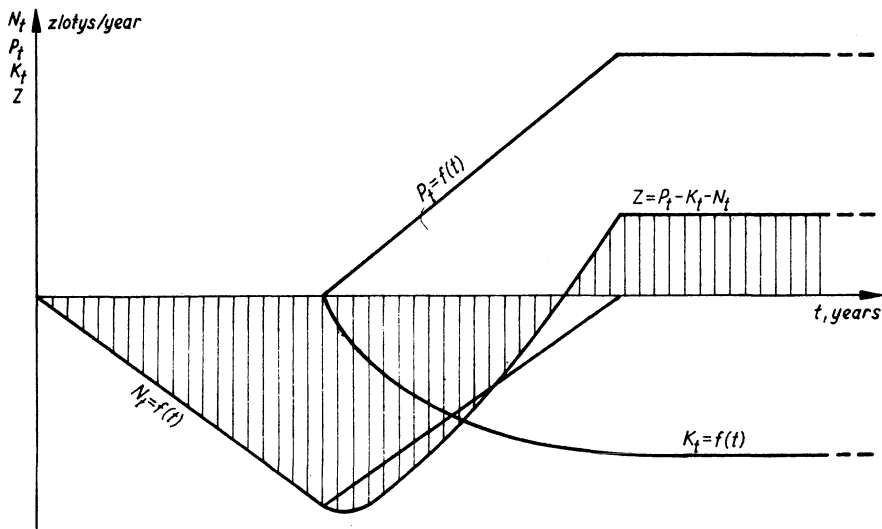

Fig. 10.1 Investment expenditure  $N_t$ , value of production  $P_t$ , production costs  $K_t$  and value of profit  $Z$  in  $t$  consecutive years of mine construction and exploitation.

$P_t$  and production costs  $K_t$  in successive years of mine construction and exploitation. Balancing these three values in the total period  $T$  of the mine construction and exploitation the capital value of investment  $W_k$  is derived, i.e.:

$$W_k = \sum_{t=1}^T (P_t - N_t - K_t) (1+r)^{-t}. \tag{10.9}$$

The condition for effectiveness is that  $W_k > 0$ . Maximization of the capital value is the aim when seeking the most advantageous design variant for the investment project.

Figure 10.2 illustrates the capital value of investment in the consecutive years of implementation and exploitation, for three different values of interest

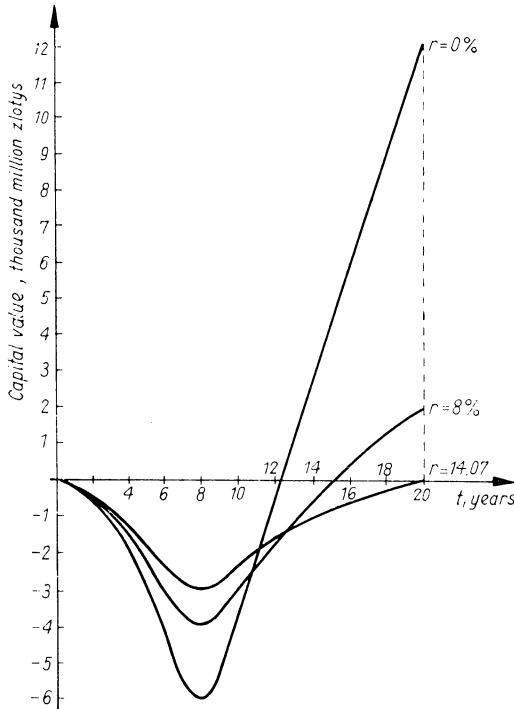

Fig. 10.2 Capital value of investment in consecutive years of implementation and exploitation with rate of interest  $r = 0\%$ ,  $r = 8\%$  and  $r = 14.07\%$  (internal interest rate). Mine with production capacity of 10 000 t/day.

rate. With a rise in the rate of interest the capital value decreases (Fig. 10.3) and in the extreme case, when the rate of interest is equal to the internal rate of interest, the capital value drops to zero.

The internal rate of interest is a calculation rate for which the sum of costs and return, discounted to the initial moment, is equal to zero. In other words, the internal rate of interest zeroes the capital value of investment. It describes the effectiveness of capital engaged in implementing the given investment, or more briefly, the profitability of this capital. Profitability of an investment is assured when the internal rate of interest is larger than the calculation rate of interest (Fig. 10.3).

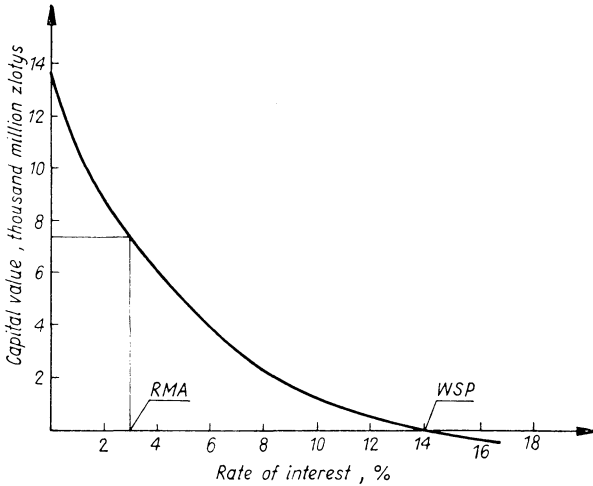

Fig. 10.3 Interpretation of minimum accepted profitability (RMA) and of internal interest rate (WSP) presented on the diagram illustrating the dependence of value of capital on the rate of interest. Mine with production capacity of 10 000 t/day.

The yearly instalment  $A_k$  also known as the annuity is the index determining the value of an updated yearly profit in a period  $T$  of investment activity. This is calculated by multiplying the value of investment capital  $W_k$  by a conversion factor, i.e.

$$A_k = W_k \frac{(i+r)^T r}{(i+r)^T - 1}. \quad (10.10)$$

The index  $A_k$  is calculated in such a way that the capital value is divided into equal yearly instalments, thus eliminating the influence of the length of calculation period  $T$  on the value of profit gained in this period.

#### 10.4 Investment Decision Making in Conditions of Risk

When making investment decisions one of many possible variants is selected. First, the external conditions existing during investment construction and exploitation must be determined, remembering that the external conditions prevailing at the moment of decision making may change in the future. External conditions are taken to mean everything that is outside the control of the decision-making body but which influences the way in which the decision is implemented and its efficiency. If we know what external situation is likely to exist in the future, but we do not know the probability factors governing

its existence, we find ourselves in an uncertain position for decision making. Hence, when the probability characteristics governing external conditions are not known, we speak of *decision making in risk conditions*. In the case of mining investments, decision making in risk conditions is typical.

The characteristics of the natural state of the deposit within the concession area of the projected mine are decided from the results of geological and geophysical prospecting. From the analysis of drilling cores and from geophysical prospecting, the quality and quantity of the mineral in the deposit may be evaluated, together with the quality of the accompanying rocks, the seam deposition characteristics and the type of overburden. The actual natural state of the deposit sometimes differs markedly from that shown in deposit geological maps. Such discrepancies may refer to the quantity of coal reserves in the deposit, the quality of coal in the seams (especially ash and barren-rock content), the deposition of seams (inclination and spatial configuration), the macro- and microtectonics of the deposit, the methane content, and the hydrogeological conditions, both in the overburden and in the deposit.

The external conditions, taken to be the characteristics of the natural state of the deposit, may improve or deteriorate relative to the state when the design decisions were made. However, both negative and positive changes in the state of the deposit will adversely influence design decisions except, of course, objectively favourable changes such as an increase in reserves resulting from more accurate prospecting of the deposit, or lower methane content than anticipated. Mining work carried out in the deposit both in the development stage (first workings) and during exploitation of the deposit (preparation and production working) makes it possible to verify the initial characteristics of the deposit as given in geological documentation. Modifications are often made both in seam maps and in design schemes already partly implemented. At the time of making basic investment decisions the selling price of coal at the future production date, and hence the value of mine production, is also uncertain. This uncertainty also applies to the true investment expenditure and deposit exploitation costs which may rise due to rising costs of labour, energy, materials and machines.

In fact, none of the elements of the balance of economic effectiveness for mining investment is known for certain, consequently the design and investment decisions are made in conditions of uncertainty or risk. However, these decisions must be based on specific parameters describing the external conditions. Therefore it is necessary to speak of a variations interval for these parameters, i.e. an interval in which these values may be taken to be true with an accepted probability. In this way the parameters of investment effectiveness are estimated considering their probability distribution.

The risk that planned investment effectiveness will not be reached results from possible, and very probable, variations in values of estimated design parameters. This risk is thus due to changes in the external conditions existing when decisions were made.

The following methods are known and applied for evaluation of the risk factor in the analysis of investment effectiveness:

*Approximate methods*

- raising the interest rate to a value covering the risk element
- reducing the profits to a value corresponding to conditions of “certainty”, i.e. minimum risk.

*Probability methods*

- *Hiller method*, i.e. analysis of the density function of the investment profitability by an analytical method
- *Herz method*, analysis of the density function of the investment profitability by an empirical method.

#### 10.4.1 *Approximate Methods*

The two approximate methods mentioned incorporate the risk directly in the index of quantitative assessment of investment profitability. This index is then decreased by an amount depending on the accuracy of evaluation of the level of risk in the particular project design. This may be achieved either by raising rate of interest in the calculation of investment effectiveness (usually by 1–2%) or by the appropriate reduction of returns from exploitation of the investment project. Neither of these methods “measures” the level of risk, but based on a subjective evaluation by the decision-maker, they reduce the anticipated investment profitability. These methods are very simple and easy to apply. The approximate methods of risk calculation are only suitable for large financial organizations which fund numerous investment undertakings, where the investment outlays are relatively small in comparison with the total financial resources of the organization.

#### 10.4.2 *Probability Methods*

Here the risk is treated differently than in the approximate methods and is not included in the evaluation of investment effectiveness. Each individual component design or its variants are characterized by two indices: the index of investment effectiveness and an index taking into account the degree of risk associated with its profitability.

From studies conducted up to now on the uncertain nature of the state of external conditions and its influence on investment profitability, it is clear that the index of investment profitability is a random variable for which the function of probability density may be determined.

The index representing investment profitability may be one of the parameters determining this function and particularly its central trend. This may be the mean value, medium, modal value. It might appear that of these parameters the modal value is the best estimate of investment profitability. However, if the profitability distribution was based only on a small number of empirical values or if there is no clear central tendency, the application of this parameter to estimate investment profitability is not advantageous. It is also considerably more convenient to make use of the mean value of probability distribution in calculations. For this reason the mean value is most frequently utilized and it would appear to be the most representative parameter for estimation of investment profitability although it is open to criticism.

To evaluate the risk associated with investment profitability, parameters may be assumed describing the probability distribution for investment profitability, i.e. the average deviation, variance and standard deviation. To measure the level of risk in the same units as the profitability, the standard deviation is taken for its measurement. To illustrate the statistical parameters governing the profitability of a projected investment design and the associated risk, the following simple example may be considered.

Two investment design variants described by the following parameters of normal distribution of profitability are assumed:

*variant I*

mean value  $m_1 = E(\xi)$ , standard deviation  $\sigma_1 = 1$ ;

*variant II*

mean value  $m_2 = E(\xi)$ , standard deviation  $\sigma_2 = 2$ , where  $m_1 = m_2$ .

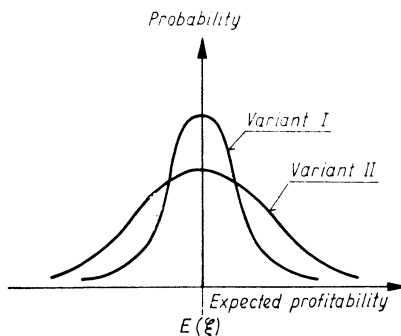

Fig. 10.4 Probability distribution of expected profitability for two design variants.

These variants are illustrated in Fig. 10.4 by the probability distributions of their profitability. Both variants have the same profitability (mean value), but they differ in the functions of probability distribution. The feasibly attainable values of investment profitability in variant I have a smaller dispersion relative to the anticipated value of profitability than in the case of variant II, which is characterized by the standard deviation. The conclusion is that variant I involves a smaller risk than variant II. The more flattened distribution of variant II indicates a larger risk since there is a greater possibility that the actual result will differ considerably from the expected. Figure 10.5 gives the inverted distribution functions for the two variants, which are called the *risk profiles*. The level of risk is more conveniently estimated from the risk profiles. They also allow the risk of incurring losses due to investment implementation to be evaluated.

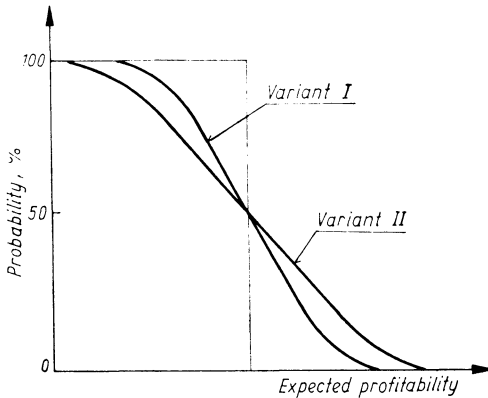

Fig. 10.5 Risk profiles for two design variants.

The *Hiller method* is a probability method based on the principle that the period of exploitation of the projected investment is known, and the flow of yearly returns and the level of investment expenditure are random variables whose mean values (expected) and variances are known. In this method analytical analyses are made of the mean value of the index of profitability assessment, its variance and an estimate of the density function.

The mean value of the index of profitability assessment indicates the level of profitability and its variance indicates the level of risk associated with this profitability.

The *Herz method*, on the other hand, is based on the assumption that the variability of investment profitability depends on a combination of mean values of each of the parameters used to calculate this profitability. The variability of profitability is determined by its density function which is found

by applying the Monte Carlo simulation method. This simulation is based on the density functions of each of the parameters determining profitability, i.e. their uncertainty profiles. The density function is obtained, i.e. the so-called risk profile, which embodies considerably more information than the mean value of profitability and its variance obtained by the Hiller method.

In practice the Monte Carlo simulation method involves the following steps:

1. The distribution function must be determined for each of the random variables occurring in the investment profitability calculation.
2. For each of these random variables a random value is selected; in this way the first Monte Carlo simulation can be carried out.
3. The value of the index of economic effectiveness of an investment is calculated using the set of values of random variables obtained.
4. Steps 2 and 3 repeated until the required number of simulations have been performed.
5. Values of the economic effectiveness of investment thus found are divided among the particular intervals. The accumulated probability giving the risk profile is also calculated.

This method simulates reality using a model in the form of risk profiles for the individual parameters describing the investment profitability. It should be noted that the risk profiles are obtained by applying subjective probability. The values of parameters used for profitability calculations in the past are studied and above all opinions of experts should be sought on the probability of such values being achieved in the future. From this data the probability distributions (density functions) for individual parameters are established.



## Bibliography

1. Asimov, M.: *An Introduction to Engineering Design*, (in Polish), Wyd. Naukowo-Techniczne, Warsaw (1975).
2. Bąbiński, C., Wolpe, M.: *Design Automation*, (in Polish), Wyd. "Arkady", Warsaw (1976).
3. Bezrukova, L. G., Malkin, A. S.: *Economic Evaluation of Projects in the Design and Development of Mines*, (in Russian), "Nedra", Moscow (1979).
4. Chudek, M., Paździora, J., Dąbrowski, J.: "Technical variants of structure and size of a modernized hard-coal mine", (in Polish), *Projekty—Problemy—Budownictwo Węglowe*, 7–8 (1979).
5. Ciszak, E.: "Design and construction of hard coal mines", *UNO Symposium "World Coal Prospects"*, Katowice, 15-23.10.1979.
6. Claes, F., Rusche, H.: "Die Berechnung von Flözbetriebskosten mit einem Programm-system für die Zuschnittsplanung", *Glückauf*, 2 (1975).
7. Cyrnek, C.: "Optimization of mine construction cycle by minimizing investment expenditure for mining development and preparation work", (in Polish), *Academy of Mining and Metallurgy, Research scripts*, sheet 462, Kraków (1974).
8. Cyrnek, C., Soliński, I.: "An attempt at optimization of deep mine construction cycle allowing for scheduled development of production", (in Polish), *Academy of Mining and Metallurgy, Research scripts*, sheet 4, Kraków (1977).
9. "Design optimization in underground coal systems", *Research and Development*, Report No. 91 (1974).
10. Dobrzycki, M.: "Complexes of mining facilities and their relations with methods for design of surface development layout in deep coal-mines", (in Polish), *Budownictwo Węglowe—Projekty—Problemy*, 7–8 (1983).
11. Dunckle, R. E., Luna, J.: "New concept in coal cleaning. Modular preparation plants", *World Coal*, 7, 6 (1981).
12. Ferencztajn, B.: "Electroenergy indices in mine design", (in Polish), *Projekty—Problemy—Budownictwo Węglowe*, 10 (1974).
13. Gaussens, J.: *Decision Making Problems in Research and Development*, (in Polish), Wydawnictwo Naukowo-Techniczne, Warsaw (1975).
14. Goliński, J.: *Optimization Methods in Technical Design*, (in Polish), Wydawnictwo Naukowo-Techniczne, Warsaw (1974).
15. Gordon, G.: *Systems Simulation*, (in Polish), Wydawnictwo Naukowo-Techniczne, Warsaw (1975).
16. Jawień, M., Magda, R.: "Optimization of siting of preparation plant and production shafts from the aspect of transport of the gotten and the cleaned product", (in Polish), *Archiwum Górnictwa*, 23, 3 (1978).

17. Jawień, M., Magda, R.: "A gradient method for taking into account factors affecting siting of the main mine surface sector", (in Polish), *Projekty—Problemy—Budownictwo Węglowe*, 7–8 (1979).
18. Jones, J. C.: *Design Methods*, (in Polish), Wydawnictwo Naukowo-Techniczne, Warsaw (1978).
19. Karbownik, A.: "A method for the design of optimum structure for a production level in a hard-coal mine", (in Polish), Doctoral thesis, Gliwice, Silesian Polytechnic (1978) (not published).
20. Karbownik, A.: "Assessment of effectiveness of shortening the implementation cycle for an investment undertaking «mines construction»", (in Polish), *Silesian Polytechnic, Research scripts*, sheet 87 (1979).
21. Karbownik, A.: "Analysis of economic criteria for evaluation of design and investment decisions", (in Polish), *Budownictwo Węglowe—Projekty—Problemy*, 8 (1982).
22. Karbownik, A.: "Taking design decisions in conditions of uncertainty", (in Polish), *Budownictwo Węglowe—Projekty—Problemy*, 1 (1983).
23. *Catalogue of standard designs for coal mining*, (in Polish), 4th ed., Główne Biuro Studiów i Projektów Górniczych, Katowice.
24. Krupiński, B.: *Principles of Mine Design*, Parts 1 and 2, (in Polish), Wydawnictwo Górniczo-Hutnicze, Katowice (1963).
25. Kryński, H.: *Balance of Economic Effectiveness of Investment Projects*, (in Polish), Państwowe Wydawnictwo Naukowe, Warsaw (1978).
26. Lama, R. D.: "Planning for the future", *Colliery Guardian*, **221**, 4 (1975).
27. Lama, R. D.: "Principles of underground coal mine design—an approach". (Part 1), *Colliery Guardian*, **225**, 5 (1977).
28. Małoszewski, J., Kostra, J.: "New technological and organizational schemes for shaft sinking and driving of main underground workings", (in Polish), *Projekty—Problemy—Budownictwo Węglowe*, 3–4 (1977).
29. Mazurek, A.: "Research studies as a basis for the design of modern mining plants", (in Polish), *Budownictwo Węglowe—Projekty—Problemy*, 7–8 (1983).
30. Moore, P. G.: *Risk in Decision Making*, (in Polish), Państwowe Wydawnictwo Ekonomiczne, Warsaw (1973).
31. Paździora, J.: "An experiment in mining investment design", (in Polish), *Życie Gospodarcze*, 1 (1974).
32. Paździora, J.: "Design of hard-coal mines", (in Polish), *Wiadomości Górnicze*, 7–8 (1974).
33. Paździora, J.: "Development of coal regions in Poland", (in Polish), *Projekty—Problemy—Budownictwo Węglowe*, 7–8 (1976).
34. Paździora, J.: "Up to dateness of project designs in the context of shortening the construction cycle for hard-coal mines", (in Polish), *Projekty—Problemy—Budownictwo Węglowe*, 3–4 (1977).
35. Paździora, J.: "Selected problems in mine design", (in Polish), *Silesian Polytechnic, scripts*, No. 920, Gliwice (1980).
36. Paździora, J.: "Complex development of the Central Coal Region in the Lublin Coal Basin", (in Polish), *Budownictwo Węglowe—Projekty—Problemy*, 9 (1982).
37. Paździora, J., Karbownik, A.: "Basic principles and mathematical model of a method for design of optimum structure of an extraction level in a hard coal mine", (in Polish), *Projekty—Problemy—Budownictwo Węglowe*, 7–8 (1978).

38. "Promis—A mine planning and production scheduling AID", *Mining Magazine*, **144**, 5 (1981).
39. Dietze, W., Steinmetz, R., Strzodka, K.: *Rationalisierung der Projektierung im Bergbau*, Deutscher Verlag für Grundstoffindustrie, Leipzig (1978).
40. Reiser, S.: "Designs for coal preparation plants in new mines", (in Polish), *Budownictwo Węglowe—Projekty—Problemy*, 12 (1983).
41. Reiser, S., Błasiak, T.: "Analysis of synthetic indices for assessing technical design variants to supplement the regulation method for assessing economic effectiveness of investment projects", (in Polish), *Projekty—Problemy—Budownictwo Węglowe*, 5 (1979).
42. Ruskey, F., Burdick, R.: "A hazard evasion program for mine planning", *US Department of the Interior*, Washington (1972).
43. Sadowski, W.: *Theory of Decision Making*, (in Polish), Państwowe Wydawnictwo Ekonomiczne, Warsaw (1974).
44. Simpson, R.: "A comparison of opening out coal deposits by means of shafts or inclined drifts", (in Polish), *Projekty—Problemy—Budownictwo Węglowe*, 3-4 (1977).
45. Skelding, S. A.: "The principles of new mine planning", *Mining Engineering*, **142**, 251 (1982).
46. Spyra, D.: "Experience and achievements in the construction of mine surface complexes from the aspect of shortening implementation cycle", (in Polish), *Projekty—Problemy—Budownictwo Węglowe*, 3-4 (1977).
47. Szarański, Z., Wróbel, K.: "New lines in the design of coal preparation plants in Poland", (in Polish), *Budownictwo Węglowe—Projekty—Problemy*, 5 (1983).
48. Tatomir, K. I.: *Fundamental Theory of Optimum Mine Design*, (in Russian), "Naukova Dumka", Kiev (1975).
49. Von Wahl, S.: "Überlegungen und Rechnungen zur Frage der günstigsten Größe von Grubenbetrieben. Theoretische Grundlagen und Beschreibung eines Modells", *Glückauf, Forschung Hefte*, sheet 3 (1967).
50. Zvjagin, P. Z., Rajchel, B. L.: "Comparative economic evaluation of the construction of new and reconstruction of existing mines of the Donets Basin", (in Russian), *Ugol'*, 9 (1967).

## Subject index

- Analysis of economic and technical indices 63
- Analysis of technical development options 63
- Annuity (yearly instalment) 221
- Approximate methods for evaluation of the risk factor 223
- Auxiliary investment 82
- Average quantity of production waste 139
  
- Balance of electric power and energy 160
- Balance of manpower 63
- Balance of reserves of useful mineral 60
- Basic investment 82
- Basic sets of the "Transmag" system 195, 198
- BIGAS method 9
- Block type development of the mine surface 48
  
  
- Cable network 168
- Calculation of economic effectiveness 217
- Capacity of a flotation machine 141
- Capital value of investment 219
- Characteristics of the deposit 80
- Characteristics of the overburden 80
- Choice of winding machine for the technological duty 175
- Coal basin 108
- Coal concentration capacity 140
- Coal deposits in:
  - Australia 15
  - Canada 16
  - FRG 16
  - Great Britain 17
  - India 18
  - People's Republic of China 15
  - Poland 18
  - USA 13
  - USSR 12
- Coal mining region 108
- Coal preparation plants 135
- Coal quality characteristics 26, 27
- Coal utilization processes 8
- Coal winning costs 213
- Complex development of mining regions 109
- Complex flow diagram of the mine production 47
- Compressed air networks 188
- Compressors 186, 187
- Conceptual design 83, 84
- Conservation project 58
- CONSOL method 9
- Cost of yearly production 74
  
  
- Dahlstrom filtration index 141
- Decision making in risk conditions 220
- Degassing 9
- Degree of voltage deformation 175
- Demand power 161-163
- Deposit conditions 23
- Deposit development 40
- Deposit tectonics 23
- Design for mining development of the deposit 110
- Design of basic set 200, 201
- Design of compressed air networks 188-190
- Design of surface heating installation 191
- Design of preparation plant 142

- Detailed mine design 86
- Determinist mathematical models of a mine 110
- Developed formula for calculation of effectiveness index 218
- Dispersed type development of the mine surface 48
- Division of the deposit 39, 41
- Dorr thickeners 141
- Double-radial electric network system 168
- Drives for winding machines 174, 175
  
- Effectiveness index 217
- Effectiveness of coal preparation 143
- Electric energy consumption 165–167
- Evaluation of economic effectiveness 72
- Exploration plan 20
- External conditions 221, 222
  
- First equipping of investment facilities 214
- Function of lifting capacity 178
- Function of lifting capacity and depth 178
  
- Gasification 9
- Graphical data of preliminary design 85
  
- Heat energy 190
- Herz method 225
- Heuristic algorithm 54
- High power drives 171
- Hiller method 225
- Hoisting diagram of winding machine 176
- Hydrogeological classification of deposits 26
- HYGAS method 9
  
- Independent supply sources 167
- Independent supply systems 167
- Index (indicator) of economic effectiveness 72, 217
  - in differential form 72, 217, 219
  - in quotient form 72, 217, 218
- Index of extraction rate 42
- Index of useful capacity of deposit 42
- Indicator formula 41–42
- Industrial reserves 81
- Initial data for design of preparation plants 138
- Internal rate of interest 220
- Inventory of fixed assets 60
- Investment activity 82
- Investment expenditure 75, 213
- Investment profitability 211
- Investment task 82
- Investment undertaking 82
  
- Loading unit 198
- Long-term mining predictions 31
- Loop electric network system 168
- Lower Silesian Coal Basin 113
- Lublin Coal Basin 122
  
- Mathematical modelling 32
- Mine construction cycle 215
- Mine infrastructure 52
- Mine redevelopment 58
- Model of mine underground section 38
- Models of distribution of investment expenditure 214, 215
- Modernization of:
  - coal preparation plant 70
  - district and main haulage systems 69
  - main winding system 69
  - mine drainage 71
  - mine railway yard 70
  - mine surface facilities 70
  - mining front 68
  - stowing 71
  - ventilation 71
- Monte Carlo simulation method 226
  
- Net workable reserves 81

- Optimum mining system 92  
 Optimum scope of mine reconstruction 59  
 Optimum size of a mine 88  
 Overburden 22
- Physical design models 31, 32  
 Pipelines in compressed air networks 188, 189  
 Polish classification of coal 28  
 Power factor 164  
 Preliminary design of a mine 84  
 Preparation plants 135  
 Principal parameters of size and model of a mine 66  
 Principles for the investment undertaking 84  
 Probability methods for evaluation of the risk factor 223  
 Probability mathematical model of a mine 110  
 Production capacity of the mine 212  
 Production capacity of the preparation plant 138  
 Programming for current mining requirements 31
- Reactive power 165  
 Reconstruction investment 58  
 Recoverable reserves 81  
 Rock liability to rock-bursts 23  
 Rybnik Coal Region 117
- Seams development 43  
 Seams with higher degree of hazard 24  
 Sectors of mine production 60, 62  
 Selecting of compensating and filtering devices 175
- Simplified formula for the effectiveness index 218  
 Spatial layout of machinery and equipment 143  
 Statistical model of a mine 110  
 Statistical parameters 224  
 Stochastic model of a mine 110  
 Storage transport chain 195  
 Strategic model of a mine 110  
 Systems design 34
- Technical specification of investment project 134  
 Technological model of preparation plant 144  
 Transformer-distribution stations 170  
 "Transmag" system 194
- Upper Silesian Basin 113
- Vertical height of fault displacement 23
- Water hazard 26  
 Watering coefficient 25  
 Winding machine parameters 176  
 Workable reserves 81  
 World coal consumption 2, 3  
 World coal production 2, 4  
 World coking-coal imports 7  
 World hard-coal reserves 5  
 World steam-coal imports 6
- Yearly repayment instalment (annuity) 221
- Zones of occurrence of coals 11