Code of Standard Practice for Steel Buildings and Bridges

March 18, 2005

Supersedes the March 7, 2000 AISC *Code of Standard Practice for Steel Buildings and Bridges* and all previous versions.

Prepared by the American Institute of Steel Construction, Inc. under the direction of the AISC Committee on the Code of Standard Practice and issued by the AISC Board of Directors.



AMERICAN INSTITUTE OF STEEL CONSTRUCTION, INC.
One East Wacker Drive, Suite 3100, Chicago, Illinois 60601-2000

Copyright © 2005

by

American Institute of Steel Construction, Inc.

All rights reserved. This book or any part thereof
must not be reproduced in any form without
the written permission of the publisher.

The information presented in this publication has been prepared in accordance with recognized engineering principles and is for general information only. While it is believed to be accurate, this information should not be used or relied upon for any specific application without competent professional examination and verification of its accuracy, suitability and applicability by a licensed engineer, architect or other professional. The publication of the material contained herein is not intended as a representation or warranty on the part of the American Institute of Steel Construction, Inc. or of any other person named herein, that this information is suitable for any general or particular use or of freedom from infringement of any patent or patents. Anyone making use of this information assumes all liability arising from such use.

Caution must be exercised when relying upon other specifications and codes developed by other bodies and incorporated by reference herein since such material may be modified or amended from time to time subsequent to the printing of this edition. The American Institute of Steel Construction, Inc. bears no responsibility for such material other than to refer to it and incorporate it by reference at the time of the initial publication of this edition.

Printed in the United States of America

PREFACE

As in any industry, trade practices have developed among those that are involved in the design, purchase, fabrication and erection of structural steel. This Code provides a useful framework for a common understanding of the acceptable standards when contracting for structural steel. As such, it is useful for owners, architects, engineers, general contractors, construction managers, fabricators, steel detailers, erectors and others that are associated with construction in structural steel. Unless specific provisions to the contrary are contained in the contract documents, the existing trade practices that are contained herein are considered to be the standard custom and usage of the industry and are thereby incorporated into the relationships between the parties to a contract.

The Symbols and Glossary are an integral part of this Code. In many sections of this Code, a non-mandatory Commentary has been prepared to provide background and further explanation for the corresponding Code provisions. The user is encouraged to consult it.

Since the first edition of this Code was published in 1924, AISC has continuously surveyed the structural steel design community and construction industry to determine standard trade practices. Since then, this Code has been periodically updated to reflect new and changing technology and industry practices.

The 2000 edition was the fifth complete revision of this Code since it was first published. The 2005 edition is not a complete revision but does add several important changes and updates. It is the result of the deliberations of a fair and balanced Committee, the membership of which included six structural engineers, two architects, one code official, one general contractor, eight fabricators, one steel detailer, three erectors, two inspectors, and one attorney. The following changes have been made in this revision:

- The intent of Section 1.1 has been clarified with additional Commentary.
- Section 1.5.2 has been modified to better address Owner-established performance criteria.
- The intent of the first sentence in Section 1.8.2 has been clarified.
- The order of paragraphs in Section 3.3 has been reversed to highlight that discovered discrepancies must be reported for resolution.
- The requirements in Section 3.4 for scale of design drawings have been modified.
- A requirement has been added in Section 4.2 for identification of Shop and Erection Drawings. Additionally, a paragraph has been added in the Commentary to this section addressing the use of independent detailing services, and the paragraph addressing the submittal schedule has been modified.
- A paragraph has been added to the Commentary in Section 4.4 addressing Shop and Erection Drawings that are approved subject to corrections noted, as well as Shop and Erection Drawings that are not approved.

- Coverage has been added of the RFI process in Section 4.6. Concurrently, explicit mention of RFIs has been added in Sections 3.5 and 4.4.2. Additionally, definitions have been added in the Glossary of the terms RFI, Clarification and Revision.
- The requirements for material identification have been modified in Section 6.1. Compatible modifications have also been made in Section 5.1.1.
- The requirements in Section 6.4.5 have been expanded to address fabricated trusses specified without camber. Compatible additions have been made in Sections 7.13.1.2(g) and (h).
- Section 7.4 has been modified to change “building lines” to “lines”.
- The Established Column Line definition in the Glossary has been changed, the definition of the term Column Line has been changed, and the usage of these terms in Section 7.5.1 has been changed for consistency with these definitions.
- Additional Commentary has been provided in Section 7.10.1 to illustrate the required description of the lateral load resisting system.
- Explicit mention of Erection Bracing Drawings has been added in the Commentary to Section 7.10.3.
- The intent of Section 8.5.5 has been clarified.
- Item 9.2.2(d) has been modified to change “detailed overall length” to “overall length”.
- Appendix A has been added to explicitly allow the user of this Code to choose to use electronic means for the exchange of project information.

By the AISC Committee on the Code of Standard Practice,

Frank B. Wylie, III, Chairman
Barry L. Barger, Vice Chairman
William A. Andrews
Paul M. Brosnahan
Richard B. Cook
William B. Cooper
William R. Davidson
Theodore L. Droessler
Donald T. Engler
Lawrence G. Griffis
D. Kirk Harman
Viji Kuruvilla
Keith G. Landwehr
James L. Larson

Rex I. Lewis
William F. McEleney
H. Scott Metzger
Leonard R. Middleton
Donald G. Moore
Homer R. Peterson, II
David B. Ratterman
Rex D. Smith
James A. Stori
Thomas S. Tarpy, Jr.
Michael J. Tylk
Michael A. West
Charles J. Carter, Secretary

TABLE OF CONTENTS

Glossary	vii
Section 1. General Provisions	1
1.1. Scope	1
1.2. Referenced Specifications, Codes and Standards	1
1.3. Units	2
1.4. Design Criteria	3
1.5. Responsibility for Design	3
1.6. Patents and Copyrights	3
1.7. Existing Structures	3
1.8. Means, Methods and Safety of Erection	4
Section 2. Classification of Materials	5
2.1. Definition of Structural Steel	5
2.2. Other Steel, Iron or Metal Items	6
Section 3. Design Drawings and Specifications	9
3.1. Structural Design Drawings and Specifications	9
3.2. Architectural, Electrical and Mechanical Design Drawings and Specifications	13
3.3. Discrepancies	13
3.4. Legibility of Design Drawings	13
3.5. Revisions to the Design Drawings and Specifications	14
3.6. Fast-Track Project Delivery	15
Section 4. Shop and Erection Drawings	16
4.1. Owner Responsibility	16
4.2. Fabricator Responsibility	16
4.3. Use of CAD Files and/or Copies of Design Drawings	17
4.4. Approval	19
4.5. Shop and/or Erection Drawings Not Furnished by the Fabricator	20
4.6. The RFI Process	21
Section 5. Materials	22
5.1. Mill Materials	22
5.2. Stock Materials	23
Section 6. Shop Fabrication and Delivery	25
6.1. Identification of Material	25
6.2. Preparation of Material	26
6.3. Fitting and Fastening	26
6.4. Fabrication Tolerances	27
6.5. Shop Cleaning and Painting	30
6.6. Marking and Shipping of Materials	32
6.7. Delivery of Materials	32

Section 7. Erection	34
7.1. Method of Erection	34
7.2. Job-Site Conditions	34
7.3. Foundations, Piers and Abutments	34
7.4. Lines and Bench Marks	35
7.5. Installation of Anchor Rods, Foundation Bolts and Other Embedded Items	35
7.6. Installation of Bearing Devices	36
7.7. Grouting	37
7.8. Field Connection Material	37
7.9. Loose Material	38
7.10. Temporary Support of Structural Steel Frames	38
7.11. Safety Protection	41
7.12. Structural Steel Frame Tolerances	42
7.13. Erection Tolerances	42
7.14. Correction of Errors	53
7.15. Cuts, Alterations and Holes for Other Trades	53
7.16. Handling and Storage	53
7.17. Field Painting	54
7.18. Final Cleaning Up	54
Section 8. Quality Assurance	55
8.1. General	55
8.2. Inspection of Mill Material	56
8.3. Non-Destructive Testing	56
8.4. Surface Preparation and Shop Painting Inspection	56
8.5. Independent Inspection	56
Section 9. Contracts	58
9.1. Types of Contracts	58
9.2. Calculation of Weights	58
9.3. Revisions to the Contract Documents	59
9.4. Contract Price Adjustment	60
9.5. Scheduling	60
9.6. Terms of Payment	61
Section 10. Architecturally Exposed Structural Steel	62
10.1. General Requirements	62
10.2. Fabrication	62
10.3. Delivery of Materials	63
10.4. Erection	64
Appendix A. Digital Building Product Models	65

GLOSSARY

The following terms are used in this Code. Where used, they are capitalized to alert the user that the term is defined in this Glossary.

AASHTO. American Association of State Highway and Transportation Officials.

Adjustable Items. See Section 7.13.1.3.

AESS. See Architecturally Exposed Structural Steel.

AISC. American Institute of Steel Construction, Inc.

Anchor Bolt. See Anchor Rod.

Anchor Rod. A mechanical device that is either cast or drilled and chemically adhered, grouted or wedged into concrete and/or masonry for the purpose of the subsequent attachment of Structural Steel.

Anchor-Rod Group. A set of Anchor Rods that receives a single fabricated Structural Steel shipping piece.

ANSI. American National Standards Institute.

Architect. The entity that is professionally qualified and duly licensed to perform architectural services.

Architecturally Exposed Structural Steel. See Section 10.

AREMA. American Railway Engineering and Maintenance of Way Association.

ASME. American Society of Mechanical Engineers.

ASTM. American Society for Testing and Materials.

AWS. American Welding Society.

Bearing Devices. Shop-attached base and bearing plates, loose base and bearing plates and leveling devices, such as leveling plates, leveling nuts and washers and leveling screws.

CASE. Council of American Structural Engineers.

Clarification. An interpretation, of the Design Drawings or Specifications that have been Released for Construction, made in response to an RFI or a note on an approval drawing and providing an explanation that neither revises the information that has been Released for Construction nor alters the cost or schedule of performance of the work.

the Code, this Code. This document, the AISC *Code of Standard Practice for Steel Buildings and Bridges* as adopted by the American Institute of Steel Construction, Inc.

Column line. The grid line of column centers set in the field based on the dimensions shown on the structural design drawings and using the building layout provided by the Owners Designated Representative for Construction. Column offsets are taken from the column line. The column line may be straight or curved as shown in the structural design drawings.

Connection. An assembly of one or more joints that is used to transmit forces between two or more members and/or connection elements.

Contract Documents. The documents that define the responsibilities of the parties that are involved in bidding, fabricating and erecting Structural Steel. These documents normally include the Design Drawings, the Specifications and the contract.

Design Drawings. The graphic and pictorial portions of the Contract Documents showing the design, location and dimensions of the work. These documents generally include plans, elevations, sections, details, schedules, diagrams and notes.

Embedment Drawings. Drawings that show the location and placement of items that are installed to receive Structural Steel.

EOR. See Structural Engineer of Record.

Engineer. See Structural Engineer of Record.

Engineer of Record. See Structural Engineer of Record.

Erection Bracing Drawings. Drawings that are prepared by the Erector to illustrate the sequence of erection, any requirements for temporary supports and the requirements for raising, bolting and/or welding. These drawings are in addition to the Erection Drawings.

Erection Drawings. Field-installation or member-placement drawings that are prepared by the Fabricator to show the location and attachment of the individual shipping pieces.

Erector. The entity that is responsible for the erection of the Structural Steel.

Established Column Line. The actual field line that is most representative of the erected column centers along a line of columns placed using the dimensions shown in the structural Design Drawings and the lines and bench marks established by the Owner's Designated Representative for Construction, to be used in applying the erection tolerances given in this Code for column shipping pieces.

Fabricator. The entity that is responsible for fabricating the Structural Steel.

Hazardous Materials. Components, compounds or devices that are either encountered during the performance of the contract work or incorporated into it containing substances that, notwithstanding the application of reasonable care, present a threat of harm to persons and/or the environment.

Inspector. The Owner's testing and inspection agency.

MBMA. Metal Building Manufacturers Association.

Mill Material. Steel mill products that are ordered expressly for the requirements of a specific project.

Owner. The entity that is identified as such in the Contract Documents.

Owner's Designated Representative for Construction. The Owner or the entity that is responsible to the Owner for the overall construction of the project, including its planning, quality and completion. This is usually the general contractor, the construction manager or similar authority at the job site.

Owner's Designated Representative for Design. The Owner or the entity that is responsible to the Owner for the overall structural design of the project, including the Structural Steel frame. This is usually the Structural Engineer of Record.

Plans. See Design Drawings.

RCSC. Research Council on Structural Connections.

Released for Construction. The term that describes the status of Contract Documents that are in such a condition that the Fabricator and the Erector can rely upon them for the performance of their work, including the ordering of material and the preparation of Shop and Erection Drawings.

Revision. An instruction or directive providing information that differs from information that has been Released for Construction. A Revision may, but does not always, impact the cost or schedule of performance of the work.

RFI. A written request for information or clarification generated during the construction phase of the project.

SER. See Structural Engineer of Record.

Shop Drawings. Drawings of the individual Structural Steel shipping pieces that are to be produced in the fabrication shop.

SJI. Steel Joist Institute.

Specifications. The portion of the Contract Documents that consists of the written requirements for materials, standards and workmanship.

SSPC. SSPC: The Society for Protective Coatings, which was formerly known as the Steel Structures Painting Council.

Standard Structural Shapes. Hot-rolled W-, S-, M- and HP-shapes, channels and angles listed in ASTM A6/A6M; structural tees split from the hot-rolled W-, S- and M-shapes listed in ASTM A6/A6M; hollow structural sections produced to ASTM A500, A501, A618 or A847; and, steel pipe produced to ASTM A53/A53M.

Steel Detailer. The entity that produces the Shop and Erection Drawings.

Structural Engineer of Record. The licensed professional who is responsible for sealing the Contract Documents, which indicates that he or she has performed or supervised the analysis, design and document preparation for the structure and has knowledge of the load-carrying structural system.

Structural Steel. The elements of the structural frame as given in Section 2.1.

Tier. The Structural Steel framing defined by a column shipping piece.

Weld Show-Through. In Architecturally Exposed Structural Steel, visual indication of the presence of a weld or welds on the side of the member opposite the weld.

CODE OF STANDARD PRACTICE FOR STEEL BUILDINGS AND BRIDGES

SECTION 1. GENERAL PROVISIONS

1.1. Scope

In the absence of specific instructions to the contrary in the Contract Documents, the trade practices that are defined in this Code shall govern the fabrication and erection of Structural Steel.

Commentary:

The practices defined in this Code are the commonly accepted standards of custom and usage for Structural Steel fabrication and erection, which generally represent the most efficient approach. This Code is not intended to define a professional standard of care for the Owners Designated Representative for Design, change the duties and responsibilities of the Owner, Contractor, Architect or Structural Engineer from those set forth in the Contract Documents, or assign to the Owner, Architect or Structural Engineer any duty or authority to undertake responsibility inconsistent with the provisions of the Contract Documents.

This Code is not applicable to steel joists or metal building systems, which are addressed by SJI and MBMA, respectively.

1.2. Referenced Specifications, Codes and Standards

The following documents are referenced in this Code:

AASHTO Specification—The 2004 AASHTO *LRFD Bridge Design Specifications*, 3rd Edition, with interims, or the 2002 AASHTO *Standard Specifications for Highway Bridges*, 17th Edition, with interims.

AISC Manual of Steel Construction—The AISC *Manual of Steel Construction*, 13th Edition.

AISC Seismic Provisions—The AISC *Seismic Provisions for Structural Steel Buildings*, March 9, 2005.

AISC Specification—The AISC *Specification for Structural Steel Buildings*, March 9, 2005.

ANSI/ASME B46.1—ANSI/ASME B46.1-95, Surface Texture (Surface Roughness, Waviness and Lay).

AREMA Specification—The 1999 AREMA *Manual for Railway Engineering, Volume II—Structures, Chapter 15*.

ASTM A6/A6M—04a, *Standard Specification for General Requirements for Rolled Structural Steel Bars, Plates, Shapes, and Sheet Piling*.

- ASTM A53/A53M—02, *Standard Specification for Pipe, Steel, Black and Hot-Dipped, Zinc-Coated, Welded and Seamless.*
- ASTM A325—04, *Standard Specification for Structural Bolts, Steel, Heat Treated, 120/105 ksi Minimum Tensile Strength.*
- ASTM A325M—04, *Standard Specification for High-Strength Bolts for Structural Steel Joints (Metric).*
- ASTM A490—04, *Standard Specification for Heat-Treated Steel Structural Bolts, 150 ksi Minimum Tensile Strength.*
- ASTMA490M—04, *Standard Specification for High-Strength Steel Bolts, Classes 10.9 and 10.9.3, for Structural Steel Joints (Metric).*
- ASTM A500—03a, *Standard Specification for Cold-Formed Welded and Seamless Carbon Steel Structural Tubing in Rounds and Shapes.* No metric equivalent exists.
- ASTM A501—01, *Standard Specification for Hot-Formed Welded and Seamless Carbon Steel Structural Tubing.* No metric equivalent exists.
- ASTM A618—04, *Standard Specification for Hot-Formed Welded and Seamless High-Strength Low-Alloy Structural Tubing.* No metric equivalent exists.
- ASTM A847—99a(2003), *Standard Specification for Cold-Formed Welded and Seamless High-Strength, Low-Alloy Structural Tubing with Improved Atmospheric Corrosion Resistance.* No metric equivalent exists.
- ASTM F1852/F1852M—04, *Standard Specification for "Twist-Off" Type Tension Control Structural Bolt/Nut/Washer Assemblies, Steel, Heat Treated, 120/105 ksi Minimum Tensile Strength.*
- AWS D1.1—The AWS D1.1 *Structural Welding Code—Steel*, 2004.
- CASE Document 11—*An Agreement Between Structural Engineer of Record and Contractor for Transfer of Computer Aided Drafting (CAD) files on Electronic Media*, 2000
- CASE Document 962—*The National Practice Guidelines for the Structural Engineer of Record*, Fourth Edition, 2000.
- RCSC Specification—*The Specification for Structural Joints Using ASTM A325 or A490 Bolts*, 2004.
- SSPC SP2—*SSPC Surface Preparation Specification No. 2, Hand Tool Cleaning*, 2004.
- SSPC SP6—*SSPC Surface Preparation Specification No. 6, Commercial Blast Cleaning*, 2004.

1.3. Units

In this Code, the values stated in either U.S. customary units or metric units shall be used. Each system shall be used independently of the other.

Commentary:

In this Code, dimensions, weights and other measures are given in U.S. customary units with rounded or rationalized metric-unit equivalents in

brackets. Because the values stated in each system are not exact equivalents, the selective combination of values from each of the two systems is not permitted.

1.4. Design Criteria

For buildings, in the absence of other design criteria, the provisions in the AISC Specification shall govern the design of the Structural Steel. For bridges, in the absence of other design criteria, the provisions in the AASHTO Specification and AREMA Specification shall govern the design of the Structural Steel, as applicable.

1.5. Responsibility for Design

- 1.5.1. When the Owner's Designated Representative for Design provides the design, Design Drawings and Specifications, the Fabricator and the Erector are not responsible for the suitability, adequacy or building-code conformance of the design.
- 1.5.2. When the Owner enters into a direct contract with the Fabricator to both design and fabricate an entire, completed steel structure, the Fabricator shall be responsible for the suitability, adequacy, conformance with Owner-established performance criteria, and building-code conformance of the Structural Steel design. The Owner shall be responsible for the suitability, adequacy and building-code conformance of the non-Structural Steel elements and shall establish the performance criteria for the Structural Steel frame.

1.6. Patents and Copyrights

The entity or entities that are responsible for the specification and/or selection of proprietary structural designs shall secure all intellectual property rights necessary for the use of those designs.

1.7. Existing Structures

- 1.7.1. Demolition and shoring of any part of an existing structure are not within the scope of work that is provided by either the Fabricator or the Erector. Such demolition and shoring shall be performed in a timely manner so as not to interfere with or delay the work of the Fabricator and the Erector.
- 1.7.2. Protection of an existing structure and its contents and equipment, so as to prevent damage from normal erection processes, is not within the scope of work that is provided by either the Fabricator or the Erector. Such protection shall be performed in a timely manner so as not to interfere with or delay the work of the Fabricator or the Erector.

16.3-4

- 1.7.3. Surveying or field dimensioning of an existing structure is not within the scope of work that is provided by either the Fabricator or the Erector. Such surveying or field dimensioning, which is necessary for the completion of Shop and Erection Drawings and fabrication, shall be performed and furnished to the Fabricator in a timely manner so as not to interfere with or delay the work of the Fabricator or the Erector.
- 1.7.4. Abatement or removal of Hazardous Materials is not within the scope of work that is provided by either the Fabricator or the Erector. Such abatement or removal shall be performed in a timely manner so as not to interfere with or delay the work of the Fabricator and the Erector.

1.8. Means, Methods and Safety of Erection

- 1.8.1. The Erector shall be responsible for the means, methods and safety of erection of the Structural Steel frame.
- 1.8.2. The Structural Engineer of Record shall be responsible for the structural adequacy of the design of the structure in the completed project. The Structural Engineer of Record shall not be responsible for the means, methods and safety of erection of the Structural Steel frame. See also Sections 3.1.4 and 7.10.

SECTION 2. CLASSIFICATION OF MATERIALS

2.1. Definition of Structural Steel

Structural Steel shall consist of the elements of the structural frame that are shown and sized in the structural Design Drawings, essential to support the design loads and described as:

- Anchor Rods that will receive Structural Steel.
- Base plates.
- Beams, including built-up beams, if made from Standard Structural Shapes and/or plates.
- Bearing plates.
- Bearings of steel for girders, trusses or bridges.
- Bracing, if permanent.
- Canopy framing, if made from Standard Structural Shapes and/or plates.
- Columns, including built-up columns, if made from Standard Structural Shapes and/or plates.
- Connection materials for framing Structural Steel to Structural Steel.
- Crane stops, if made from Standard Structural Shapes and/or plates.
- Door frames, if made from Standard Structural Shapes and/or plates and if part of the Structural Steel frame.
- Edge angles and plates, if attached to the Structural Steel frame or steel (open-web) joists.
- Embedded Structural Steel parts, other than bearing plates, that will receive Structural Steel.
- Expansion joints, if attached to the Structural Steel frame.
- Fasteners for connecting Structural Steel items: permanent shop bolts, nuts and washers; shop bolts, nuts and washers for shipment; field bolts, nuts and washers for permanent Connections; and, permanent pins.
- Floor-opening frames, if made from Standard Structural Shapes and/or plates and attached to the Structural Steel frame or steel (open-web) joists.
- Floor plates (checkered or plain), if attached to the Structural Steel frame.
- Girders, including built-up girders, if made from Standard Structural Shapes and/or plates.
- Girts, if made from Standard Structural Shapes.
- Grillage beams and girders.
- Hangers, if made from Standard Structural Shapes, plates and/or rods and framing Structural Steel to Structural Steel.
- Leveling nuts and washers.
- Leveling plates.
- Leveling screws.
- Lintels, if attached to the Structural Steel frame.
- Marquee framing, if made from Standard Structural Shapes and/or plates.

- Machinery supports, if made from Standard Structural Shapes and/or plates and attached to the Structural Steel frame.
- Monorail elements, if made from Standard Structural Shapes and/or plates and attached to the Structural Steel frame.
- Posts, if part of the Structural Steel frame.
- Purlins, if made from Standard Structural Shapes.
- Relieving angles, if attached to the Structural Steel frame.
- Roof-opening frames, if made from Standard Structural Shapes and/or plates and attached to the Structural Steel frame or steel (open-web) joists.
- Roof-screen support frames, if made from Standard Structural Shapes.
- Sag rods, if part of the Structural Steel frame and connecting Structural Steel to Structural Steel.
- Shear stud connectors, if specified to be shop attached.
- Shims, if permanent.
- Struts, if permanent and part of the Structural Steel frame.
- Tie rods, if part of the Structural Steel frame.
- Trusses, if made from Standard Structural Shapes and/or built-up members.
- Wall-opening frames, if made from Standard Structural Shapes and/or plates and attached to the Structural Steel frame.
- Wedges, if permanent.

Commentary:

The Fabricator normally fabricates the items listed in Section 2.1. Such items must be shown, sized and described in the structural Design Drawings. Bracing includes vertical bracing for resistance to wind and seismic load and structural stability, horizontal bracing for floor and roof systems and permanent stability bracing for components of the Structural Steel frame.

2.2. Other Steel, Iron or Metal Items

Structural Steel shall not include other steel, iron or metal items that are not generally described in Section 2.1, even where such items are shown in the structural Design Drawings or are attached to the Structural Steel frame. Other steel, iron or metal items include but are not limited to:

- Bearings, if non-steel.
- Cables for permanent bracing or suspension systems.
- Castings.
- Catwalks.
- Chutes.
- Cold-formed steel products.
- Cold-rolled steel products, except those that are specifically covered in the AISC Specification.
- Corner guards.

Crane rails, splices, bolts and clamps.
 Crane stops, if not made from Standard Structural Shapes or plates.
 Door guards.
 Embedded steel parts, other than bearing plates, that do not receive Structural Steel or that are embedded in precast concrete.
 Expansion joints, if not attached to the Structural Steel frame.
 Flagpole support steel.
 Floor plates (checkered or plain), if not attached to the Structural Steel frame.
 Forgings.
 Gage-metal products.
 Grating.
 Handrail.
 Hangers, if not made from Standard Structural Shapes, plates and/or rods or not framing Structural Steel to Structural Steel.
 Hoppers.
 Items that are required for the assembly or erection of materials that are furnished by trades other than the Fabricator or Erector.
 Ladders.
 Lintels, if not attached to the Structural Steel frame.
 Masonry anchors.
 Miscellaneous metal.
 Ornamental metal framing.
 Pressure vessels.
 Reinforcing steel for concrete or masonry.
 Relieving angles, if not attached to the Structural Steel frame.
 Roof screen support frames, if not made from Standard Structural Shapes.
 Safety cages.
 Shear stud connectors, if specified to be field installed.
 Stacks.
 Stairs.
 Steel deck.
 Steel (open-web) joists.
 Steel joist girders.
 Tanks.
 Toe plates.
 Trench or pit covers.

Commentary:

Section 2.2 includes many items that may be furnished by the Fabricator if contracted to do so by specific notation and detail in the Contract Documents. When such items are contracted to be provided by the Fabricator, coordination will normally be required between the Fabricator and other material suppliers

and trades. The provisions in this Code are not intended to apply to items in Section 2.2.

In previous editions of this Code, provisions regarding who should normally furnish field-installed shear stud connectors and cold-formed steel deck support angles were included in Section 7.8. These provisions have been eliminated since field-installed shear stud connectors and steel deck support angles are not defined as Structural Steel in this Code.

SECTION 3. DESIGN DRAWINGS AND SPECIFICATIONS

3.1. Structural Design Drawings and Specifications

Unless otherwise indicated in the Contract Documents, the structural Design Drawings shall be based upon consideration of the design loads and forces to be resisted by the Structural Steel frame in the completed project.

The structural Design Drawings shall clearly show the work that is to be performed and shall give the following information with sufficient dimensions to accurately convey the quantity and nature of the Structural Steel to be fabricated:

- (a) The size, section, material grade and location of all members;
- (b) All geometry and working points necessary for layout;
- (c) Floor elevations;
- (d) Column centers and offsets;
- (e) The camber requirements for members; and,
- (f) The information that is required in Sections 3.1.1 through 3.1.6.

The Structural Steel Specification shall include any special requirements for the fabrication and erection of the Structural Steel.

The structural Design Drawings, Specifications and addenda shall be numbered and dated for the purposes of identification.

Commentary:

Contract Documents vary greatly in complexity and completeness. Nonetheless, the Fabricator and the Erector must be able to rely upon the accuracy and completeness of the Contract Documents. This allows the Fabricator and the Erector to provide the Owner with bids that are adequate and complete. It also enables the preparation of the Shop and Erection Drawings, the ordering of materials and the timely fabrication and erection of shipping pieces.

In some cases, the Owner can benefit when reasonable latitude is allowed in the Contract Documents for alternatives that can reduce cost without compromising quality. However, critical requirements that are necessary to protect the Owner's interest, that affect the integrity of the structure or that are necessary for the Fabricator and the Erector to proceed with their work must be included in the Contract Documents. Some examples of critical information include:

Standard specifications and codes that govern Structural Steel design and construction, including bolting and welding.

Material specifications.

Special material requirements to be reported on the certified mill test reports.

Welded-joint configuration.

Weld-procedure qualification.
 Special requirements for work of other trades.
 Final disposition of backing bars and runoff tabs.
 Lateral bracing.
 Stability bracing.
 Connections or data for Connection selection and/or completion.
 Restrictions on Connection types.
 Column stiffeners (also known as continuity plates).
 Column web doubler plates.
 Bearing stiffeners on beams and girders.
 Web reinforcement.
 Openings for other trades.
 Surface preparation and shop painting requirements.
 Shop and field inspection requirements.
 Non-destructive testing requirements, including acceptance criteria.
 Special requirements on delivery.
 Special erection limitations.
 Identification of non-Structural Steel elements that interact with the
 Structural Steel frame to provide for the lateral stability of the
 Structural Steel frame (see Section 3.1.4).
 Column differential shortening information.
 Special fabrication and erection tolerances for AESS.
 Special pay-weight provisions.

- 3.1.1. Permanent bracing, column stiffeners, column web doubler plates, bearing stiffeners in beams and girders, web reinforcement, openings for other trades and other special details, where required, shall be shown in sufficient detail in the structural Design Drawings so that the quantity, detailing and fabrication requirements for these items can be readily understood.
- 3.1.2. The Owner's Designated Representative for Design shall either show the complete design of the Connections in the structural Design Drawings or allow the Fabricator to select or complete the Connection details while preparing the Shop and Erection Drawings. When the Fabricator is allowed to select or complete the Connection details, the following information shall be provided in the structural Design Drawings:
- (a) Any restrictions on the types of Connections that are permitted;
 - (b) Data concerning the loads, including shears, moments, axial forces and transfer forces, that are to be resisted by the individual members and their Connections, sufficient to allow the Fabricator to select or complete the Connection details while preparing the Shop and Erection Drawings;
 - (c) Whether the data required in (b) is given at the service-load level or the factored-load level; and,

- (d) Whether LRFD or ASD is to be used in the selection or completion of Connection details.

When the Fabricator selects or completes the Connection details, the Fabricator shall utilize the requirements in the AISC Specification and the Contract Documents and submit the Connection details to the Owner's Designated Representative for Design for approval.

Commentary:

When the Owner's Designated Representative for Design shows the complete design of the Connections in the structural Design Drawings, the following information is included:

- (a) All weld sizes and lengths;
- (b) All bolt sizes, locations, quantities and grades;
- (c) All plate and angle sizes, thicknesses and dimensions; and,
- (d) All work point locations and related information.

The intent of this approach is that complete information necessary for Connection detailing, fabrication and erection is shown in the structural Design Drawings. The Steel Detailer will then be able to transfer this information to the Shop and Erection Drawings, applying it to the individual pieces being detailed.

When the Owner's Designated Representative for Design allows the Fabricator to select or complete the Connections, this is commonly done by referring to tables in the Contract Documents or in the AISC Manual of Steel Construction, or by schematically showing the types of Connections required in the structural Design Drawings. The Steel Detailer will then configure the Connections based upon the design loads and other information given in the structural Design Drawings. If the desired Connection is not covered in those tables, a detail of the "special" Connection should be contained in the structural Design Drawings. This detail should provide such information as weld sizes, plate thicknesses and quantities of bolts. However, there may be some geometry and dimensional information that the Steel Detailer must develop. The intent of this method is that the Steel Detailer will select the Connection materials and configuration from the referenced tables or complete the specific Connection configuration (i.e. dimensions, edge distances and bolt spacing) based upon the Connection details that are shown in the structural Design Drawings.

This method will require the skill of an experienced Steel Detailer, who is familiar with the AISC requirements for Connection configurations, capable and experienced in the use of the Connection tables in the AISC Manual of Steel Construction and capable of calculating dimensions and adapting a typical Connection detail to similar situations. Notations of loadings in the structural Design Drawings are only to facilitate selection of the Connections from the

referenced tables. It is not the intent of this method that the Steel Detailer practice engineering.

If there are any restrictions as to the types of Connections to be used, particularly as it relates to simple shear Connections, it is required that these limitations be set forth in the structural Design Drawings and Specifications. There are a variety of Connections available in the AISC Manual of Steel Construction for a given situation. Preference for a particular type will vary between Fabricators and Erectors. Stating these limitations, if any, in the structural Design Drawings and Specifications will help to avoid repeated changes to the Shop and Erection Drawings due to the selection of a Connection that is not acceptable to the Owner's Designated Representative for Design, thereby avoiding additional cost and/or delay for the redrawing of the Shop and Erection Drawings.

The structural Design Drawings must indicate the method of design used as LRFD or ASD. In order to conform to the spirit of the AISC Specification, the Connections must be selected using the same method and the corresponding references.

- 3.1.3. When leveling plates are to be furnished as part of the contract requirements, their locations and required thickness and sizes shall be specified in the Contract Documents.
- 3.1.4. When the Structural Steel frame, in the completely erected and fully connected state, requires interaction with non-Structural Steel elements (see Section 2) for strength and/or stability, those non-Structural Steel elements shall be identified in the Contract Documents as required in Section 7.10.

Commentary:

Examples of non-Structural Steel elements include diaphragms made of steel deck, diaphragms made of concrete on steel deck and masonry and/or concrete shear walls.

- 3.1.5. When camber is required, the magnitude, direction and location of camber shall be specified in the structural Design Drawings.

Commentary:

For cantilevers, the specified camber may be up or down, depending upon the framing and loading.

- 3.1.6. Specific members or portions thereof that are to be left unpainted shall be identified in the Contract Documents. When shop painting is required, the painting requirements shall be specified in the Contract Documents, including the following information:

- (a) The identification of specific members or portions thereof to be painted;
- (b) The surface preparation that is required for these members;
- (c) The paint specifications and manufacturer's product identification that are required for these members; and,
- (d) The minimum dry-film shop-coat thickness that is required for these members.

Commentary:

Some members or portions thereof may be required to be left unpainted, such as those that will be in contact and acting compositely with concrete, or those that will receive spray-applied fire protection materials.

3.2. Architectural, Electrical and Mechanical Design Drawings and Specifications

All requirements for the quantities, sizes and locations of Structural Steel shall be shown or noted in the structural Design Drawings. The use of architectural, electrical and/or mechanical Design Drawings as a supplement to the structural Design Drawings is permitted for the purposes of defining detail configurations and construction information.

3.3. Discrepancies

When discrepancies exist between the Design Drawings and Specifications, the Design Drawings shall govern. When discrepancies exist between scale dimensions in the Design Drawings and the figures written in them, the figures shall govern. When discrepancies exist between the structural Design Drawings and the architectural, electrical or mechanical Design Drawings or Design Drawings for other trades, the structural Design Drawings shall govern.

When a discrepancy is discovered in the Contract Documents in the course of the Fabricator's work, the Fabricator shall promptly notify the Owner's Designated Representative for Construction so that the discrepancy can be resolved by the Owner's Designated Representative for Design. Such resolution shall be timely so as not to delay the Fabricator's work. See Sections 3.5 and 9.3.

Commentary:

While it is the Fabricator's responsibility to report any discrepancies that are discovered in the Contract Documents, it is not the Fabricator's responsibility to discover discrepancies, including those that are associated with the coordination of the various design disciplines. The quality of the Contract Documents is the responsibility of the entities that produce those documents.

3.4. Legibility of Design Drawings

Design Drawings shall be clearly legible and drawn to an identified scale that is appropriate to clearly convey the information.

Commentary:

Historically, the most commonly accepted scale for structural steel plans has been 1/8 in. per ft [10 mm per 1 000 mm]. There are, however, situations where a smaller or larger scale is appropriate. Ultimately, consideration must be given to the clarity of the drawing.

The scaling of the Design Drawings to determine dimensions is not an accepted practice for detailing the Shop and Erection Drawings. However, it should be remembered when preparing Design Drawings that scaling may be the only method available when early-submission drawings are used to determine dimensions for estimating and bidding purposes.

3.5. Revisions to the Design Drawings and Specifications

Revisions to the Design Drawings and Specifications shall be made either by issuing new Design Drawings and Specifications or by reissuing the existing Design Drawings and Specifications. In either case, all Revisions, including Revisions that are communicated through responses to RFIs or the annotation of Shop and/or Erection Drawings (see Section 4.4.2), shall be clearly and individually indicated in the Contract Documents. The Contract Documents shall be dated and identified by Revision number. Each Design Drawing shall be identified by the same drawing number throughout the duration of the project, regardless of the Revision. See also Section 9.3.

Commentary:

Revisions to the Design Drawings and Specifications can be made by issuing sketches and supplemental information separate from the Design Drawings and Specifications. These sketches and supplemental information become amendments to the Design Drawings and Specifications and are considered new Contract Documents. All sketches and supplemental information must be uniquely identified with a number and date as the latest instructions until such time as they may be superseded by new information.

When revisions are made by revising and re-issuing the existing structural Design Drawings and/or Specifications, a unique revision number and date must be added to those documents to identify that information as the latest instructions until such time as they may be superseded by new information. The same unique drawing number must identify each Design Drawing throughout the duration of the project so that revisions can be properly tracked, thus avoiding confusion and miscommunication among the various entities involved in the project.

When revisions are communicated through the annotation of Shop or Erection Drawings or contractor submissions, such changes must be confirmed in writing by one of the aforementioned methods. This written confirmation is imperative to maintain control of the cost and schedule of a project and to avoid potential errors in fabrication.

3.6. **Fast-Track Project Delivery**

When the fast-track project delivery system is selected, release of the structural Design Drawings and Specifications shall constitute a Release for Construction, regardless of the status of the architectural, electrical, mechanical and other interfacing designs and Contract Documents. Subsequent revisions, if any, shall be the responsibility of the Owner and shall be made in accordance with Sections 3.5 and 9.3.

Commentary:

The fast-track project delivery system generally provides for a condensed schedule for the design and construction of a project. Under this delivery system, the Owner elects to Release for Construction the structural Design Drawings and Specifications, which may be partially complete, at a time that may precede the completion of and coordination with architectural, mechanical, electrical and other design work and Contract Documents. The release of these structural Design Drawings and Specifications may also precede the release of the General Conditions and Division 1 Specifications.

Release of the structural Design Drawings and Specifications to the Fabricator for ordering of material constitutes a Release for Construction. Accordingly, the Fabricator and the Erector may begin their work based upon those partially complete documents. As the architectural, mechanical, electrical and other design elements of the project are completed, revisions may be required in design and/or construction. Thus, when considering the fast-track project delivery system, the Owner should balance the potential benefits to the project schedule with the project cost contingency that may be required to allow for these subsequent revisions.

SECTION 4. SHOP AND ERECTION DRAWINGS

4.1. Owner Responsibility

The Owner shall furnish, in a timely manner and in accordance with the Contract Documents, complete structural Design Drawings and Specifications that have been Released for Construction. Unless otherwise noted, Design Drawings that are provided as part of a contract bid package shall constitute authorization by the Owner that the Design Drawings are Released for Construction

Commentary:

When the Owner issues Released-for-Construction Design Drawings and Specifications, the Fabricator and the Erector rely on the fact that these are the Owner's requirements for the project. This release is required by the Fabricator prior to the ordering of material and the preparation and completion of Shop and Erection Drawings.

To ensure the orderly flow of material procurement, detailing, fabrication and erection activities, on phased construction projects, it is essential that designs are not continuously revised after they have been Released for Construction. In essence, once a portion of a design is Released for Construction, the essential elements of that design should be "frozen" to ensure adherence to the contract price and construction schedule. Alternatively, all parties should reach a common understanding of the effects of future changes, if any, as they affect scheduled deliveries and added costs.

4.2. Fabricator Responsibility

Except as provided in Section 4.5, the Fabricator shall produce Shop and Erection Drawings for the fabrication and erection of the Structural Steel and is responsible for the following:

- (a) The transfer of information from the Contract Documents into accurate and complete Shop and Erection Drawings; and,
- (b) The development of accurate, detailed dimensional information to provide for the fit-up of parts in the field.

Each Shop and Erection Drawing shall be identified by the same drawing number throughout the duration of the project and shall be identified by revision number and date, with each specific revision clearly identified.

When the Fabricator submits a request to change Connection details that are described in the Contract Documents, the Fabricator shall notify the Owner's Designated Representatives for Design and Construction in writing in advance of the submission of the Shop and Erection Drawings. The Owner's Designated Representative for Design shall review and approve or reject the request in a timely manner.

When requested to do so by the Owner's Designated Representative for Design, the Fabricator shall provide to the Owner's Designated Representatives for Design and Construction its schedule for the submittal of Shop and Erection Drawings so as to facilitate the timely flow of information between all parties.

Commentary:

The fabricator is permitted to use the services of independent detailers to produce shop and erection drawings and to perform other support services such as producing advanced bills of material and bolt summaries.

As the Fabricator develops the detailed dimensional information for production of the Shop and Erection Drawings, there may be discrepancies, missing information or conflicts discovered in the Contract Documents. See Section 3.3.

When the Fabricator intends to make a submission of alternative Connection details to those shown in the Contract Documents, the Fabricator must notify the Owner's Designated Representatives for Design and Construction in advance. This will allow the parties involved to plan for the increased effort that may be required to review the alternative Connection details. In addition, the Owner will be able to evaluate the potential for cost savings and/or schedule improvements against the additional design cost for review of the alternative Connection details by the Owner's Designated Representative for Design. This evaluation by the Owner may result in the rejection of the alternative Connection details or acceptance of the submission for review based upon cost savings, schedule improvements and/or job efficiencies.

The Owner's Designated Representative for Design may request the Fabricator's schedule for the submittal of shop and erection drawings. This process is intended to allow the parties to plan for the staffing demands of the submission schedule. The Contract Documents may address this issue in more detail. In the absence of the requirement to provide this schedule, none need be provided.

When the Fabricator provides a schedule for the submission of the Shop and Erection Drawings, it must be recognized that this schedule may be affected by revisions and the response time to requests for missing information or the resolution of discrepancies.

4.3. Use of CAD Files and/or Copies of Design Drawings

The Fabricator shall neither use nor reproduce any part of the Design Drawings as part of the Shop or Erection Drawings without the written permission of the Owner's Designated Representative for Design. When CAD files or copies of the Design Drawings are made available for the Fabricator's use, the Fabricator shall accept this information under the following conditions:

- (a) All information contained in the CAD files or copies of the Design Drawings shall be considered instruments of service of the Owner's Designated Representative for Design and shall not be used for other projects, additions to the project or the completion of the project by others. CAD files and copies of the Design Drawings shall remain the property of the Owner's Designated Representative for Design and in no case shall the transfer of these CAD files or copies of the Design Drawings be considered a sale.
- (b) The CAD files or copies of the Design Drawings shall not be considered to be Contract Documents. In the event of a conflict between the Design Drawings and the CAD files or copies thereof, the Design Drawings shall govern;
- (c) The use of CAD files or copies of the Design Drawings shall not in any way obviate the Fabricator's responsibility for proper checking and coordination of dimensions, details, member sizes and fit-up and quantities of materials as required to facilitate the preparation of Shop and Erection Drawings that are complete and accurate as required in Section 4.2; and,
- (d) The Fabricator shall remove information that is not required for the fabrication or erection of the Structural Steel from the CAD files or copies of the Design Drawings.

Commentary:

With the advent of electronic media and the internet, electronic copies of Design Drawings are becoming readily available to the Fabricator. As a result, the Owner's Designated Representative for Design may have reduced control over the unauthorized use of the Design Drawings. There are many copyright and other legal issues to be considered.

The Owner's Designated Representative for Design may choose to make CAD files or copies of the Design Drawings available to the Fabricator, and may charge a service or licensing fee for this convenience. In doing so, a carefully negotiated agreement should be established to set out the specific responsibilities of both parties in view of the liabilities involved for both parties. For a sample contract, see CASE Document 11.

The CAD files and/or copies of the Design Drawings are provided to the Fabricator for convenience only. The information therein should be adapted for use only in reference to the placement of Structural Steel members during erection. The Fabricator should treat this information as if it were fully produced by the Fabricator and undertake the same level of checking and quality assurance. When amendments or revisions are made to the Contract Documents, the Fabricator must update this reference material.

When CAD files or copies of the Design Drawings are provided to the Fabricator, they often contain other information, such as architectural backgrounds or references to other Contract Documents. This additional

material should be removed when producing Shop and Erection Drawings to avoid the potential for confusion.

4.4. **Approval**

Except as provided in Section 4.5, the Shop and Erection Drawings shall be submitted to the Owner's Designated Representatives for Design and Construction for review and approval. These drawings shall be returned to the Fabricator within 14 calendar days. Approved Shop and Erection Drawings shall be individually annotated by the Owner's Designated Representatives for Design and Construction as either approved or approved subject to corrections noted. When so required, the Fabricator shall subsequently make the corrections noted and furnish corrected Shop and Erection Drawings to the Owner's Designated Representatives for Design and Construction.

Commentary:

As used in this Code, the 14-day allotment for the return of Shop and Erection Drawings is intended to represent the Fabricator's portal-to-portal time. The intent in this Code is that, in the absence of information to the contrary in the Contract Documents, 14 days may be assumed for the purposes of bidding, contracting and scheduling. A submittal schedule is commonly used to facilitate the approval process.

If a Shop or Erection Drawing is approved subject to corrections noted, the Owner's Designated Representative for Design may or may not require that it be re-submitted for record purposes following correction. If a Shop or Erection Drawing is not approved, revisions must be made and the drawing re-submitted until approval is achieved.

- 4.4.1. Approval of the Shop and Erection Drawings, approval subject to corrections noted and similar approvals shall constitute the following:
- (a) Confirmation that the Fabricator has correctly interpreted the Contract Documents in the preparation of those submittals;
 - (b) Confirmation that the Owner's Designated Representative for Design has reviewed and approved the Connection details shown on the Shop and Erection Drawings and submitted in accordance with Section 3.1.2, if applicable; and,
 - (c) Release by the Owner's Designated Representatives for Design and Construction for the Fabricator to begin fabrication using the approved submittals.

Such approval shall not relieve the Fabricator of the responsibility for either the accuracy of the detailed dimensions in the Shop and Erection Drawings or the general fit-up of parts that are to be assembled in the field.

The Fabricator shall determine the fabrication schedule that is necessary to meet the requirements of the contract.

Commentary:

When considering the current language in this Section, the Committee sought language that would parallel the practices of CASE. In CASE Document 962, CASE indicates that when the design of some element of the primary structural system is left to someone other than the Structural Engineer of Record, "...such elements, including connections designed by others, should be reviewed by the Structural Engineer of Record. He [or she] should review such designs and details, accept or reject them and be responsible for their effects on the primary structural system." Historically, this Code has embraced this same concept.

From the inception of this Code, AISC and the industry in general have recognized that only the Owner's Designated Representative for Design has all the information necessary to evaluate the total impact of Connection details on the overall structural design of the project. This authority has traditionally been exercised during the approval process for Shop and Erection Drawings. The Owner's Designated Representative for Design has thus retained responsibility for the adequacy and safety of the entire structure since at least the 1927 edition of this Code.

- 4.4.2. Unless otherwise noted, any additions, deletions or Revisions that are indicated in responses to RFIs or on the approved Shop and Erection Drawings shall constitute authorization by the Owner that the additions, deletions or revisions are Released for Construction. The Fabricator and the Erector shall promptly notify the Owner's Designated Representative for Construction when any direction or notation in responses to RFIs or on the Shop or Erection Drawings or other information will result in an additional cost and/or a delay. See Sections 3.5 and 9.3.

Commentary:

When the Fabricator notifies the Owner's Designated Representative for Construction that a direction or notation in responses to RFIs or on the Shop or Erection Drawings will result in an additional cost or a delay, it is then normally the responsibility of the Owner's Designated Representative for Construction to subsequently notify the Owner's Designated Representative for Design.

4.5. Shop and/or Erection Drawings Not Furnished by the Fabricator

When the Shop and Erection Drawings are not prepared by the Fabricator, but are furnished by others, they shall be delivered to the Fabricator in a timely manner. These Shop and Erection Drawings shall be prepared, insofar as is practical, in accordance with the shop fabrication and detailing standards of the Fabricator. The Fabricator shall neither be responsible for the completeness or

accuracy of Shop and Erection Drawings so furnished, nor for the general fit-up of the members that are fabricated from them.

4.6. **The RFI Process**

When Requests for Information (RFIs) are issued, the process shall include the maintenance of a written record of inquiries and responses related to interpretation and implementation of the Contract Documents, including the Clarifications and/or Revisions to the Contract Documents that result, if any. RFIs shall not be used for the incremental Release for Construction of Design Drawings. When RFIs involve discrepancies or Revisions, see Sections 3.3, 3.5, and 4.4.2.

Commentary:

The RFI process is most commonly used during the detailing process, but can also be used to forward inquiries by the Erector or to inform the Owners Designated Representative For Design in the event of a fabricator or erector error and to develop corrective measures to resolve such errors.

The RFI process is intended to provide a written record of inquiries and associated responses but not to replace all verbal communication between the parties on the project. RFIs should be prepared and responded to in a timely fashion so as not to delay the work of the Detailer, Fabricator, and Erector. Discussion of the RFI issues and possible solutions between the Fabricator, Erector, and Owner's Designated Representatives for Design and Construction often can facilitate timely and practical resolution. Unlike Shop and Erection Drawing submittals in Section 4.2, RFI response time can vary depending on the urgency of the issue, the amount of work required by the Owner's Designated Representatives for Design and Construction to develop a complete response, and other circumstances such as building official approval.

RFIs should be prepared in a standardized format, including RFI number and date, identity of the author, reference to a specific Design Drawing number (and specific detail as applicable) or Specification section, the needed response date, a description of a suggested solution (graphic depictions are recommended for more complex issues), and an indication of possible schedule and cost impacts. RFIs should be limited to one question each (unless multiple questions are interrelated to the same issue) to facilitate the resolution and minimize response time. Questions and proposed solutions presented in RFIs should be clear and complete. RFI responses should be equally clear and complete in the depictions of the solutions, and signed and dated by the responding party.

Unless otherwise noted, the Fabricator/Erector can assume that a response to an RFI constitutes a Release for Construction. However, if the response will result in an increase in cost or a delay in schedule, Section 4.4.2 requires that the Fabricator/Erector promptly inform the Owner's Designated Representatives for Design and Construction.

SECTION 5. MATERIALS

5.1. Mill Materials

Unless otherwise noted in the Contract Documents, the Fabricator is permitted to order the materials that are necessary for fabrication when the Fabricator receives Contract Documents that have been Released for Construction.

Commentary:

The Fabricator may purchase materials in stock lengths, exact lengths or multiples of exact lengths to suit the dimensions shown in the structural Design Drawings. Such purchases will normally be job-specific in nature and may not be suitable for use on other projects or returned for full credit if subsequent design changes make these materials unsuitable for their originally intended use. The Fabricator should be paid for these materials upon delivery from the mill, subject to appropriate additional payment or credit if subsequent unanticipated modification or reorder is required. Purchasing materials to exact lengths is not considered fabrication.

- 5.1.1. Unless otherwise specified by means of special testing requirements in the Contract Documents, mill testing shall be limited to those tests that are required for the material in the ASTM specifications indicated in the Contract Documents. Materials ordered to special material requirements shall be marked by the supplier as specified in ASTM A6/A6M Section 12 prior to delivery to the Fabricator's shop or other point of use. Such material not so marked by the supplier, shall not be used until:
- (a) Its identification is established by means of testing in accordance with the applicable ASTM specifications; and,
 - (b) A Fabricator's identification mark, as described in Section 6.1.2 and 6.1.3, has been applied.
- 5.1.2. When Mill Material does not satisfy ASTM A6/A6M tolerances for camber, profile, flatness or sweep, the Fabricator shall be permitted to perform corrective procedures, including the use of controlled heating and/or mechanical straightening, subject to the limitations in the AISC Specification.

Commentary:

Mill dimensional tolerances are completely set forth in ASTM A6/A6M. Normal variations in the cross-sectional geometry of Standard Structural Shapes must be recognized by the designer, the Fabricator, the Steel Detailer and the Erector (for example, see Figure C-5.1). Such tolerances are mandatory because roll wear, thermal distortions of the hot cross-section immediately after leaving the forming rolls and differential cooling distortions that take place on the cooling beds are all unavoidable. Geometric perfection of the cross-section is

not necessary for either structural or architectural reasons, if the tolerances are recognized and provided for.

ASTM A6/A6M also stipulates tolerances for straightness that are adequate for typical construction. However, these characteristics may be controlled or corrected to closer tolerances during the fabrication process when the added cost is justified by the special requirements for an atypical project.

- 5.1.3. When variations that exceed ASTM A6/A6M tolerances are discovered or occur after the receipt of Mill Material the Fabricator shall, at the Fabricator's option, be permitted to perform the ASTM A6/A6M corrective procedures for mill reconditioning of the surface of Structural Steel shapes and plates.
- 5.1.4. When special tolerances that are more restrictive than those in ASTM A6/A6M are required for Mill Materials, such special tolerances shall be specified in the Contract Documents. The Fabricator shall, at the Fabricator's option, be permitted to order material to ASTM A6/A6M tolerances and subsequently perform the corrective procedures described in Sections 5.1.2 and 5.1.3.

5.2. Stock Materials

- 5.2.1. If used for structural purposes, materials that are taken from stock by the Fabricator shall be of a quality that is at least equal to that required in the ASTM specifications indicated in the Contract Documents.
- 5.2.2. Certified mill test reports shall be accepted as sufficient record of the quality of materials taken from stock by the Fabricator. The Fabricator shall review and retain the certified mill test reports that cover such stock materials. However, the Fabricator need not maintain records that identify individual pieces of stock material against individual certified mill test reports, provided the Fabricator purchases stock materials that meet the requirements for material grade and quality in the applicable ASTM specifications.
- 5.2.3. Stock materials that are purchased under no particular specification, under a specification that is less rigorous than the applicable ASTM specifications or without certified mill test reports or other recognized test reports shall not be used without the approval of the Owner's Designated Representative for Design.

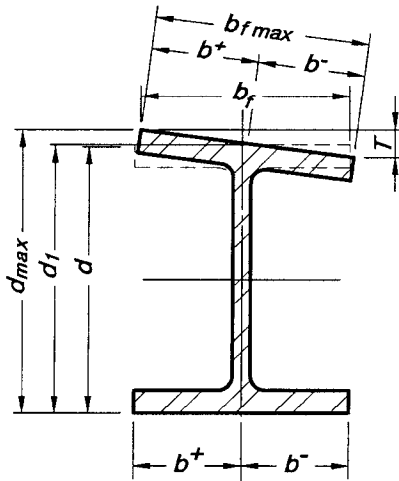

U.S. customary units:

Flange-tilt tolerances:

$$T + T' = 1/4" \text{ in. for } d \leq 12 \text{ in.}$$

$$= 5/16" \text{ in. for } d > 12 \text{ in.}$$

Actual depth with tolerances:

$$d_1 = d \text{ plus or minus } 1/8 \text{ in. (typ.)}$$

$$d_{max} = d + T + T'$$

Actual flange width with tolerances:

$$b^+ = 1/2 b_f \text{ plus or minus } 3/16 \text{ in.}$$

$$b^- = 1/2 b_f \text{ minus or plus } 3/16 \text{ in.}$$

$$b_{max} = b_f \text{ plus } 1/4 \text{ in. or minus } 3/16 \text{ in.}$$

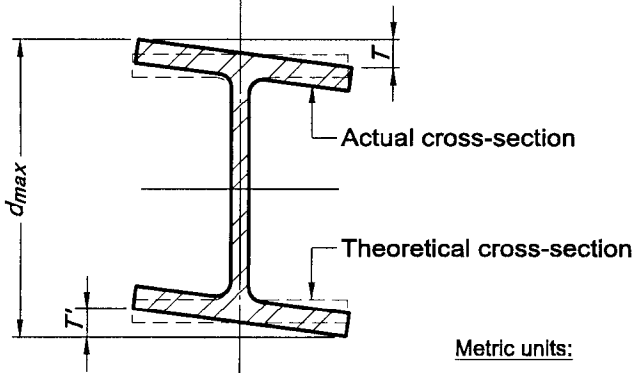

Metric units:

Flange-tilt tolerances:

$$T + T' = 6 \text{ mm for } d \leq 300 \text{ mm}$$

$$= 8 \text{ mm for } d > 300 \text{ mm}$$

Actual depth with tolerances:

$$d_1 = d \text{ plus or minus } 3 \text{ mm}$$

$$d_{max} = d + T + T'$$

Actual flange width with tolerances:

$$b^+ = 1/2 b_f \text{ plus or minus } 5 \text{ mm}$$

$$b^- = 1/2 b_f \text{ minus or plus } 5 \text{ mm}$$

$$b_{max} = b_f \text{ plus } 6 \text{ mm or minus } 5 \text{ mm}$$

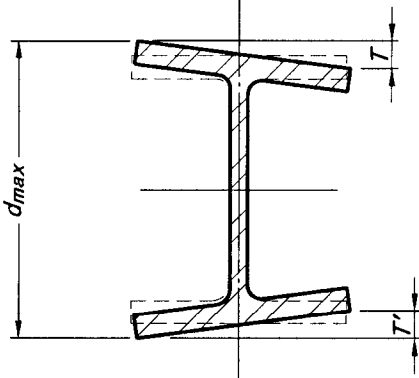

Figure C-5.1. Mill tolerances on the cross-section of a W-shape.

SECTION 6. SHOP FABRICATION AND DELIVERY

6.1. Identification of Material

6.1.1. The Fabricator shall be able to demonstrate by written procedure and actual practice a method of material identification, visible up to the point of assembling members as follows:

- (a) For shop-standard material, identification capability shall include shape designation. Representative mill test reports shall be furnished by the Fabricator if requested to do so by the Owner's Designated Representative for Design, either in the Contract Documents or in separate written instructions given to the Fabricator prior to ordering Mill Materials.
- (b) For material of grade other than shop-standard material, identification capability shall include shape designation and material grade. Representative mill test reports shall be furnished by the Fabricator if requested to do so by the Owner's Designated Representative for Design, either in the Contract Documents or in separate written instructions given to the Fabricator prior to ordering Mill Materials.
- (c) For material ordered in accordance with an ASTM supplement or other special material requirements in the Contract Documents, identification capability shall include shape designation, material grade, and heat number. The corresponding mill test reports shall be furnished by the Fabricator if requested to do so by the Owner's Designated Representative for Design, either in the Contract Documents or in separate written instructions given to the Fabricator prior to ordering Mill Materials.

Unless an alternative system is established in the Fabricator's written procedures, shop-standard material shall be as follows:

Material	Shop-standard material grade
W and WT	ASTM A992
M, S, MT and ST	ASTM A36
HP	ASTM A36
L	ASTM A36
C and MC	ASTM A36
HSS	ASTM A500 grade B
Steel Pipe	ASTM A53 grade B
Plates and Bars	ASTM A36

Commentary:

The requirements in Section 6.1.1(a) will suffice for most projects. When material is of a strength level that differs from the shop-standard grade, the requirements in Section 6.1.1(b) apply. When special material requirements

apply, such as ASTM A6/A6M supplement S5 or S30 for CVN testing, ASTM A6/A6M supplement S8 for ultrasonic testing, or ASTM A588/A588M for atmospheric corrosion resistance, the requirements in Section 6.1.1(c) are applicable.

- 6.1.2. During fabrication, up to the point of assembling members, each piece of material that is ordered to special material requirements shall carry a Fabricator's identification mark or an original supplier's identification mark. The Fabricator's identification mark shall be in accordance with the Fabricator's established material identification system, which shall be on record and available prior to the start of fabrication for the information of the Owner's Designated Representative for Construction, the building-code authority and the Inspector.
- 6.1.3. Members that are made of material that is ordered to special material requirements shall not be given the same assembling or erection mark as members made of other material, even if they are of identical dimensions and detail.

6.2. Preparation of Material

- 6.2.1. The thermal cutting of Structural Steel by hand-guided or mechanically guided means is permitted.
- 6.2.2. Surfaces that are specified as "finished" in the Contract Documents shall have a roughness height value measured in accordance with ANSI/ASME B46.1 that is equal to or less than 500. The use of any fabricating technique that produces such a finish is permitted.

Commentary:

Most cutting processes, including friction sawing and cold sawing, and milling processes meet a surface roughness limitation of 500 per ANSI/ASME B46.1.

6.3. Fitting and Fastening

- 6.3.1. Projecting elements of Connection materials need not be straightened in the connecting plane, subject to the limitations in the AISC Specification.
- 6.3.2. Backing bars and runoff tabs shall be used in accordance with AWS D1.1 as required to produce sound welds. The Fabricator or Erector need not remove backing bars or runoff tabs unless such removal is specified in the Contract Documents. When the removal of backing bars is specified in the Contract Documents, such removal shall meet the requirements in AWS D1.1. When the removal of runoff tabs is specified in the Contract Documents, hand flame-

cutting close to the edge of the finished member with no further finishing is permitted, unless other finishing is specified in the Contract Documents.

Commentary:

In most cases, the treatment of backing bars and runoff tabs is left to the discretion of the Owner's Designated Representative for Design. In some cases, treatment beyond the basic cases described in this Section may be required. As one example, special treatment is required for backing bars and runoff tabs in beam-to-column moment Connections when the requirements in the AISC Seismic Provisions must be met. In all cases, the Owner's Designated Representative for Design should specify the required treatments in the Contract Documents.

- 6.3.3. Unless otherwise noted in the Shop Drawings, high-strength bolts for shop-attached Connection material shall be installed in the shop in accordance with the requirements in the AISC Specification.

6.4. Fabrication Tolerances

The tolerances on Structural Steel fabrication shall be in accordance with the requirements in Section 6.4.1 through 6.4.6.

Commentary:

Fabrication tolerances are stipulated in several specifications and codes, each applicable to a specialized area of construction. Basic fabrication tolerances are stipulated in this Section. For Architecturally Exposed Structural Steel, see Section 10. Other specifications and codes are also commonly incorporated by reference in the Contract Documents, such as the AISC Specification, the RCSC Specification, AWS D1.1 and the AASHTO Specification.

- 6.4.1. For members that have both ends finished (see Section 6.2.2) for contact bearing, the variation in the overall length shall be equal to or less than 1/32 in. [1 mm]. For other members that frame to other Structural Steel elements, the variation in the detailed length shall be as follows:
- (a) For members that are equal to or less than 30 ft [9 000 mm] in length, the variation shall be equal to or less than 1/16 in. [2 mm].
 - (b) For members that are greater than 30 ft [9 000 mm] in length, the variation shall be equal to or less than 1/8 in. [3 mm].
- 6.4.2. For straight structural members other than compression members, whether of a single Standard Structural Shape or built-up, the variation in straightness shall be equal to or less than that specified for wide-flange shapes in ASTM A6/A6M, except when a smaller variation in straightness is specified in the Contract Documents. For straight compression members, whether of a Standard

Structural Shape or built-up, the variation in straightness shall be equal to or less than $1/1000$ of the axial length between points that are to be laterally supported. For curved structural members, the variation from the theoretical curvature shall be equal to or less than the variation in sweep that is specified for an equivalent straight member of the same straight length in ASTM A6/A6M.

In all cases, completed members shall be free of twists, bends and open joints. Sharp kinks or bends shall be cause for rejection.

- 6.4.3. For beams and trusses that are detailed without specified camber, the member shall be fabricated so that, after erection, any incidental camber due to rolling or shop fabrication is upward.
- 6.4.4. For beams that are specified in the Contract Documents with camber, beams received by the Fabricator with 75% of the specified camber shall require no further cambering. Otherwise, the variation in camber shall be as follows:
- (a) For beams that are equal to or less than 50 ft [15 000 mm] in length, the variation shall be equal to or less than minus zero / plus 1/2 in. [13 mm].
 - (b) For beams that are greater than 50 ft [15 000 mm] in length, the variation shall be equal to or less than minus zero / plus 1/2 in. plus 1/8 in. for each 10 ft or fraction thereof [13 mm plus 3 mm for each 3 000 mm or fraction thereof] in excess of 50 ft [15 000 mm] in length.

For the purpose of inspection, camber shall be measured in the Fabricator's shop in the unstressed condition.

Commentary:

There is no known way to inspect beam camber after the beam is received in the field because of factors that include:

- (a) The release of stresses in members over time and in varying applications;
- (b) The effects of the dead weight of the member;
- (c) The restraint caused by the end Connections in the erected state; and,
- (d) The effects of additional dead load that may ultimately be intended to be applied, if any.

Therefore, inspection of the Fabricator's work on beam camber must be done in the fabrication shop in the unstressed condition.

- 6.4.5. For fabricated trusses that are specified in the Contract Documents with camber, the variation in camber at each specified camber point shall be equal to or less than plus or minus $1/800$ of the distance to that point from the nearest point of support. For the purpose of inspection, camber shall be measured in the Fabricator's shop in the unstressed condition. For fabricated trusses that are

specified in the Contract Documents without indication of camber, the foregoing requirements shall be applied at each panel point of the truss with a zero camber ordinate.

Commentary:

There is no known way to inspect truss camber after the truss is received in the field because of factors that include:

- (a) The effects of the dead weight of the member;
- (b) The restraint caused by the truss Connections in the erected state; and,
- (c) The effects of additional dead load that may ultimately be intended to be applied, if any.

Therefore, inspection of the Fabricator's work on truss camber must be done in the fabrication shop in the unstressed condition. See Figure C-6.1.

6.4.6. When permissible variations in the depths of beams and girders result in abrupt changes in depth at splices, such deviations shall be accounted for as follows:

- (a) For splices with bolted joints, the variations in depth shall be taken up with filler plates; and,
- (b) For splices with welded joints, the weld profile shall be adjusted to conform to the variations in depth, the required cross-section of weld shall be provided and the slope of the weld surface shall meet the requirements in AWS D1.1.

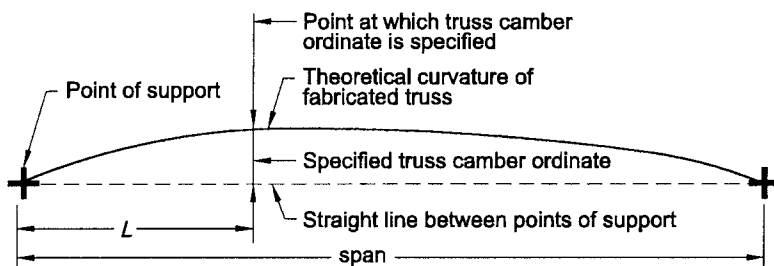

Taking L as the distance from the point at which truss camber is specified to the closer point of support, in. [mm], the tolerance on truss camber at that point is calculated as $L/800$. L must be equal to or less than one-half the span.

Figure C-6.1. Illustration of the tolerance on camber for fabricated trusses with specified camber.

6.5. Shop Cleaning and Painting (see also Section 3.1.6)

Structural Steel that does not require shop paint shall be cleaned of oil and grease with solvent cleaners, and of dirt and other foreign material by sweeping with a fiber brush or other suitable means. For Structural Steel that is required to be shop painted, the requirements in Sections 6.5.1 through 6.5.4 shall apply.

Commentary:

Extended exposure of unpainted Structural Steel that has been cleaned for the subsequent application of fire protection materials can be detrimental to the fabricated product. Most levels of cleaning require the removal of all loose mill scale, but permit some amount of tightly adhering mill scale. When a piece of Structural Steel that has been cleaned to an acceptable level is left exposed to a normal environment, moisture can penetrate behind the scale, and some “lifting” of the scale by the oxidation process is to be expected. Cleanup of “lifted” mill scale is not the responsibility of the Fabricator, but is to be assigned by contract requirement to an appropriate contractor.

Section 6.5.4 of this Code is not applicable to weathering steel, for which special cleaning specifications are always required in the Contract Documents.

- 6.5.1. The Fabricator is not responsible for deterioration of the shop coat that may result from exposure to ordinary atmospheric conditions or corrosive conditions that are more severe than ordinary atmospheric conditions.

Commentary:

The shop coat of paint is the prime coat of the protective system. It is intended as protection for only a short period of exposure in ordinary atmospheric conditions, and is considered a temporary and provisional coating.

- 6.5.2. Unless otherwise specified in the Contract Documents, the Fabricator shall, as a minimum, hand clean the Structural Steel of loose rust, loose mill scale, dirt and other foreign matter, prior to painting, by means of wire brushing or by other methods elected by the Fabricator, to meet the requirements of SSPC-SP2. If the Fabricator’s workmanship on surface preparation is to be inspected by the Inspector, such inspection shall be performed in a timely manner prior to the application of the shop coat.

Commentary:

The selection of a paint system is a design decision involving many factors including:

- (a) The Owner’s preference;

- (b) The service life of the structure;
- (c) The severity of environmental exposure;
- (d) The cost of both initial application and future renewals; and,
- (e) The compatibility of the various components that comprise the paint system (surface preparation, shop coat and subsequent coats).

Because the inspection of shop painting must be concerned with workmanship at each stage of the operation, the Fabricator provides notice of the schedule of operations and affords the Inspector access to the work site. Inspection must then be coordinated with that schedule so as to avoid delay of the scheduled operations.

Acceptance of the prepared surface must be made prior to the application of the shop coat because the degree of surface preparation cannot be readily verified after painting. Time delay between surface preparation and the application of the shop coat can result in unacceptable deterioration of a properly prepared surface, necessitating a repetition of surface preparation. This is especially true with blast-cleaned surfaces. Therefore, to avoid potential deterioration of the surface, it is assumed that surface preparation is accepted unless it is inspected and rejected prior to the scheduled application of the shop coat.

The shop coat in any paint system is designed to maximize the wetting and adherence characteristics of the paint, usually at the expense of its weathering capabilities. Deterioration of the shop coat normally begins immediately after exposure to the elements and worsens as the duration of exposure is extended. Consequently, extended exposure of the shop coat will likely lead to its deterioration and may necessitate repair, possibly including the repetition of surface preparation and shop coat application in limited areas. With the introduction of high-performance paint systems, avoiding delay in the application of the shop coat has become more critical. High-performance paint systems generally require a greater degree of surface preparation, as well as early application of weathering protection for the shop coat.

Since the Fabricator does not control the selection of the paint system, the compatibility of the various components of the total paint system, or the length of exposure of the shop coat, the Fabricator cannot guarantee the performance of the shop coat or any other part of the system. Instead, the Fabricator is responsible only for accomplishing the specified surface preparation and for applying the shop coat (or coats) in accordance with the Contract Documents.

This Section stipulates that the Structural Steel is to be cleaned to meet the requirements in SSPC-SP2. This stipulation is not intended to represent an exclusive cleaning level, but rather the level of surface preparation that will be furnished unless otherwise specified in the Contract Documents if the Structural Steel is to be painted.

Further information regarding shop painting is available in *A Guide to Shop Painting of Structural Steel*, published jointly by SSPC and AISC.

- 6.5.3. Unless otherwise specified in the Contract Documents, paint shall be applied by brushing, spraying, rolling, flow coating, dipping or other suitable means, at the election of the Fabricator. When the term “shop coat”, “shop paint” or other equivalent term is used with no paint system specified, the Fabricator’s standard shop paint shall be applied to a minimum dry-film thickness of one mil [25 µm].
- 6.5.4. Touch-up of abrasions caused by handling after painting shall be the responsibility of the contractor that performs touch-up in the field or field painting.

Commentary:

Touch-up in the field and field painting are not normally part of the Fabricator’s or the Erector’s contract.

6.6. Marking and Shipping of Materials

- 6.6.1. Unless otherwise specified in the Contract Documents, erection marks shall be applied to the Structural Steel members by painting or other suitable means.
- 6.6.2. Bolt assemblies and loose bolts, nuts and washers shall be shipped in separate closed containers according to length and diameter, as applicable. Pins and other small parts and packages of bolts, nuts and washers shall be shipped in boxes, crates, kegs or barrels. A list and description of the material shall appear on the outside of each closed container.

Commentary:

In most cases bolts, nuts and other components in a fastener assembly can be shipped loose in separate containers. However, ASTM F1852/F1852M twist-off-type tension-control bolt assemblies and galvanized ASTM A325, A325M and F1852/F1852M bolt assemblies must be assembled and shipped in the same container according to length and diameter.

6.7. Delivery of Materials

- 6.7.1. Fabricated Structural Steel shall be delivered in a sequence that will permit efficient and economical fabrication and erection, and that is consistent with requirements in the Contract Documents. If the Owner or Owner’s Designated Representative for Construction wishes to prescribe or control the sequence of delivery of materials, that entity shall specify the required sequence in the Contract Documents. If the Owner’s Designated Representative for Construction contracts separately for delivery and for erection, the Owner’s

Designated Representative for Construction shall coordinate planning between contractors.

- 6.7.2. Anchor Rods, washers, nuts and other anchorage or grillage materials that are to be built into concrete or masonry shall be shipped so that they will be available when needed. The Owner's Designated Representative for Construction shall allow the Fabricator sufficient time to fabricate and ship such materials before they are needed.
- 6.7.3. If any shortage is claimed relative to the quantities of materials that are shown in the shipping statements, the Owner's Designated Representative for Construction or the Erector shall promptly notify the Fabricator so that the claim can be investigated.

Commentary:

The quantities of material that are shown in the shipping statement are customarily accepted as correct by the Owner's Designated Representative for Construction, the Fabricator and the Erector.

- 6.7.4. Unless otherwise specified in the Contract Documents, and subject to the approved Shop and Erection Drawings, the Fabricator shall limit the number of field splices to that consistent with minimum project cost.

Commentary:

This Section recognizes that the size and weight of Structural Steel assemblies may be limited by shop capabilities, the permissible weight and clearance dimensions of available transportation or job-site conditions.

- 6.7.5. If material arrives at its destination in damaged condition, the receiving entity shall promptly notify the Fabricator and carrier prior to unloading the material, or promptly upon discovery prior to erection.

SECTION 7. ERECTION

7.1. Method of Erection

Fabricated Structural Steel shall be erected using methods and a sequence that will permit efficient and economical performance of erection, and that is consistent with the requirements in the Contract Documents. If the Owner or Owner's Designated Representative for Construction wishes to prescribe or control the method and/or sequence of erection, or specifies that certain members cannot be erected in their normal sequence, that entity shall specify the required method and sequence in the Contract Documents. If the Owner's Designated Representative for Construction contracts separately for fabrication services and for erection services, the Owner's Designated Representative for Construction shall coordinate planning between contractors.

Commentary:

Design modifications are sometimes requested by the Erector to allow or facilitate the erection of the Structural Steel frame. When this is the case, the Erector should notify the Fabricator prior to the preparation of Shop and Erection Drawings so that the Fabricator may refer the Erector's request to the Owner's Designated Representatives for Design and Construction for resolution.

7.2. Job-Site Conditions

The Owner's Designated Representative for Construction shall provide and maintain the following for the Fabricator and the Erector:

- (a) Adequate access roads into and through the job site for the safe delivery and movement of the material to be erected and of derricks, cranes, trucks and other necessary equipment under their own power;
- (b) A firm, properly graded, drained, convenient and adequate space at the job site for the operation of the Erector's equipment, free from overhead obstructions, such as power lines, telephone lines or similar conditions; and,
- (c) Adequate storage space, when the structure does not occupy the full available job site, to enable the Fabricator and the Erector to operate at maximum practical speed.

Otherwise, the Owner's Designated Representative for Construction shall inform the Fabricator and the Erector of the actual job-site conditions and/or special delivery requirements prior to bidding.

7.3. Foundations, Piers and Abutments

The accurate location, strength and suitability of, and access to, all foundations, piers and abutments shall be the responsibility of the Owner's Designated Representative for Construction.

7.4. **Lines and Bench Marks**

The Owner's Designated Representative for Construction shall be responsible for the accurate location of lines and benchmarks at the job site and shall furnish the Erector with a plan that contains all such information. The Owner's Designated Representative for Construction shall establish offset lines and reference elevations at each level for the Erector's use in the positioning of Adjustable Items (see Section 7.13.1.3), if any.

7.5. **Installation of Anchor Rods, Foundation Bolts and Other Embedded Items**

7.5.1. Anchor Rods, foundation bolts and other embedded items shall be set by the Owner's Designated Representative for Construction in accordance with Embedment Drawings that have been approved by the Owner's Designated Representatives for Design and Construction. The variation in location of these items from the dimensions shown in the Embedment Drawings shall be as follows:

- (a) The variation in dimension between the centers of any two Anchor Rods within an Anchor-Rod Group shall be equal to or less than 1/8 in. [3 mm].
- (b) The variation in dimension between the centers of adjacent Anchor-Rod Groups shall be equal to or less than 1/4 in. [6 mm].
- (c) The variation in elevation of the tops of Anchor Rods shall be equal to or less than plus or minus 1/2 in. [13 mm].
- (d) The accumulated variation in dimension between centers of Anchor-Rod Groups along the Column Line through multiple Anchor-Rod Groups shall be equal to or less than 1/4 in. per 100 ft [2 mm per 10 000 mm], but not to exceed a total of 1 in. [25 mm].
- (e) The variation in dimension from the center of any Anchor-Rod Group to the Column Line through that group shall be equal to or less than 1/4 in. [6 mm].

The tolerances that are specified in (b), (c) and (d) shall apply to offset dimensions shown in the structural Design Drawings, measured parallel and perpendicular to the nearest Column Line, for individual columns that are shown in the structural Design Drawings as offset from Column Lines.

Commentary:

The tolerances established in this Section have been selected for compatibility with the holes sizes that are recommended for base plates in the AISC Manual of Steel Construction. If special conditions require more restrictive tolerances, the contractor responsible for setting the Anchor Rods should be so informed in the Contract Documents. When the Anchor Rods are set in sleeves, the

adjustment provided may be used to satisfy the required Anchor-Rod setting tolerances.

- 7.5.2. Unless otherwise specified in the Contract Documents, Anchor Rods shall be set with their longitudinal axis perpendicular to the theoretical bearing surface.
- 7.5.3. Embedded items and Connection materials that are part of the work of other trades, but that will receive Structural Steel, shall be located and set by the Owner's Designated Representative for Construction in accordance with an approved Embedment Drawing. The variation in location of these items shall be limited to a magnitude that is consistent with the tolerances that are specified in Section 7.13 for the erection of the Structural Steel.
- 7.5.4. All work that is performed by the Owner's Designated Representative for Construction shall be completed so as not to delay or interfere with the work of the Fabricator and the Erector. The Owner's Designated Representative for Construction shall conduct a survey of the as-built locations of Anchor Rods, foundation bolts and other embedded items, and shall verify that all items covered in Section 7.5 meet the corresponding tolerances. When corrective action is necessary, the Owner's Designated Representative for Construction shall obtain the guidance and approval of the Owner's Designated Representative for Design.

Commentary:

Few Fabricators or Erectors have the capability to provide this survey. Under standard practice, it is the responsibility of others.

7.6. Installation of Bearing Devices

All leveling plates, leveling nuts and washers and loose base and bearing plates that can be handled without a derrick or crane are set to line and grade by the Owner's Designated Representative for Construction. Loose base and bearing plates that require handling with a derrick or crane shall be set by the Erector to lines and grades established by the Owner's Designated Representative for Construction. The Fabricator shall clearly scribe loose base and bearing plates with lines or other suitable marks to facilitate proper alignment.

Promptly after the setting of Bearing Devices, the Owner's Designated Representative for Construction shall check them for line and grade. The variation in elevation relative to the established grade for all Bearing Devices shall be equal to or less than plus or minus 1/8 in. [3 mm]. The final location of Bearing Devices shall be the responsibility of the Owner's Designated Representative for Construction.

Commentary:

The 1/8 in. [3 mm] tolerance on elevation of Bearing Devices relative to established grades is provided to permit some variation in setting Bearing Devices, and to account for the accuracy that is attainable with standard surveying instruments. The use of leveling plates larger than 22 in. by 22 in. [550 mm by 550 mm] is discouraged and grouting is recommended with larger sizes. For the purposes of erection stability, the use of leveling nuts and washers is discouraged when base plates have less than four Anchor Rods.

7.7. Grouting

Grouting shall be the responsibility of the Owner's Designated Representative for Construction. Leveling plates and loose base and bearing plates shall be promptly grouted after they are set and checked for line and grade. Columns with attached base plates, beams with attached bearing plates and other similar members with attached Bearing Devices that are temporarily supported on leveling nuts and washers, shims or other similar leveling devices, shall be promptly grouted after the Structural Steel frame or portion thereof has been plumbed.

Commentary:

In the majority of structures the vertical load from the column bases is transmitted to the foundations through structural grout. In general, there are three methods by which support is provided for column bases during erection:

- (a) Pre-grouted leveling plates or loose base plates;
- (b) Shims; and,
- (c) Leveling nuts and washers on the Anchor Rods beneath the column base.

Standard practice provides that loose base plates and leveling plates are to be grouted as they are set. Bearing Devices that are set on shims or leveling nuts are grouted after plumbing, which means that the weight of the erected Structural Steel frame is supported on the shims or washers, nuts and Anchor Rods. The Erector must take care to ensure that the load that is transmitted in this temporary condition does not exceed the strength of the shims or washers, nuts and Anchor Rods. These considerations are presented in greater detail in AISC Design Guides No. 1 and 10.

7.8. Field Connection Material

- 7.8.1. The Fabricator shall provide field Connection details that are consistent with the requirements in the Contract Documents and that will, in the Fabricator's opinion, result in economical fabrication and erection.

- 7.8.2. When the Fabricator is responsible for erecting the Structural Steel, the Fabricator shall furnish all materials that are required for both temporary and permanent Connection of the component parts of the Structural Steel frame.
- 7.8.3. When the erection of the Structural Steel is not performed by the Fabricator, the Fabricator shall furnish the following field Connection material:
- (a) Bolts, nuts and washers of the required grade, type and size and in sufficient quantity for all Structural Steel-to-Structural Steel field Connections that are to be permanently bolted, including an extra 2 percent of each bolt size (diameter and length);
 - (b) Shims that are shown as necessary for make-up of permanent Structural Steel-to-Structural Steel Connections; and,
 - (c) Backing bars and run-off tabs that are required for field welding.
- 7.8.4. The Erector shall furnish all welding electrodes, fit-up bolts and drift pins used for the erection of the Structural Steel.

Commentary:

See the commentary for Section 2.2.

7.9. Loose Material

Unless otherwise specified in the Contract Documents, loose Structural Steel items that are not connected to the Structural Steel frame shall be set by the Owner's Designated Representative for Construction without assistance from the Erector.

7.10. Temporary Support of Structural Steel Frames

- 7.10.1. The Owner's Designated Representative for Design shall identify the following in the Contract Documents:
- (a) The lateral-load-resisting system and connecting diaphragm elements that provide for lateral strength and stability in the completed structure; and,
 - (b) Any special erection conditions or other considerations that are required by the design concept, such as the use of shores, jacks or loads that must be adjusted as erection progresses to set or maintain camber, position within specified tolerances or prestress.

Commentary:

The intent of Section 7.10.1 of the Code is to alert the Owners Designated Representative for Construction and the Erector of the means for lateral load resistance in the completed structure so that appropriate planning can occur for

construction of the building. Examples of a description of the lateral load resisting system as required by 7.10.1(a) are shown below.

Example 1 is an all-steel building with a composite metal deck and concrete floor system. All lateral load resistance is provided by welded moment frames in each orthogonal building direction. One suitable description of this lateral load resisting system is:

All lateral load resistance and stability of the building in the completed structure is provided by moment frames with welded beam to column connections framed in each orthogonal direction (see plan sheets for locations). The composite metal deck and concrete floors serve as horizontal diaphragms that distribute the lateral wind and seismic forces horizontally to the vertical moment frames. The vertical moment frames carry the applied lateral loads to the building foundation.

Example 2 is a steel-framed building with a composite metal deck and concrete floor system. All beam-to-column connections are simple connections and all lateral load resistance is provided by reinforced concrete shear walls in the building core and in the stair wells. One suitable description of this lateral load resisting system is:

All lateral load resistance and stability of the building in the completed structure is provided exclusively by cast-in-place reinforced concrete shear walls in the building core and stair wells (see plan sheets for locations). These walls provide all lateral load resistance in each orthogonal building direction. The composite metal deck and concrete floors serve as horizontal diaphragms that distribute the lateral wind and seismic forces horizontally to the concrete shear walls. The concrete shear walls carry the applied lateral loads to the building foundation.

See also Commentary Section 7.10.3.

- 7.10.2. The Owner's Designated Representative for Construction shall indicate to the Erector prior to bidding, the installation schedule for non-Structural Steel elements of the lateral-load-resisting system and connecting diaphragm elements identified by the Owner's Designated Representative for Design in the Contract Documents.

Commentary:

See Commentary Section 7.10.3.

- 7.10.3. Based upon the information provided in accordance with Sections 7.10.1 and 7.10.2, the Erector shall determine, furnish and install all temporary supports, such as temporary guys, beams, falsework, cribbing or other elements required for the erection operation. These temporary supports shall be sufficient to secure the bare Structural Steel framing or any portion thereof against loads that are

likely to be encountered during erection, including those due to wind and those that result from erection operations.

The Erector need not consider loads during erection that result from the performance of work by, or the acts of, others, except as specifically identified by the Owner's Designated Representatives for Design and Construction, nor those that are unpredictable, such as loads due to hurricane, tornado, earthquake, explosion or collision.

Temporary supports that are required during or after the erection of the Structural Steel frame for the support of loads caused by non-Structural Steel elements, including cladding, interior partitions and other such elements that will induce or transmit loads to the Structural Steel frame during or after erection, shall be the responsibility of others.

Commentary:

Many Structural Steel frames have lateral-load-resisting systems that are activated during the erection process. Such lateral-load-resisting systems may consist of welded moment frames, braced frames or, in some instances, columns that cantilever from fixed-base foundations. Such frames are normally braced with temporary guys that, together with the steel deck floor and roof diaphragms, or other diaphragm bracing that may be included as part of the design, provide stability during the erection process. The guy cables are also commonly used to plumb the Structural Steel frame. The Erector normally furnishes and installs the required temporary supports and bracing to secure the bare Structural Steel frame, or portion thereof, during the erection process. When Erection Bracing Drawings are required in the Contract Documents, those drawings show this information.

If the Owner's Designated Representative for Construction determines that steel decking is not installed by the Erector, temporary diaphragm bracing may be required if a horizontal diaphragm is not available to distribute loads to the vertical and lateral load resisting system. If the steel deck will not be available as a diaphragm during Structural Steel erection, the Owner's Designated Representative for Construction must communicate this condition to the Erector prior to bidding. If such diaphragm bracing is required, it must be furnished and installed by the Erector.

Sometimes structural systems that are employed by the Owner's Designated Representative for Design rely upon other elements besides the Structural Steel frame for lateral-load resistance. For instance, concrete or masonry shear walls or precast spandrels may be used to provide resistance to vertical and lateral loads in the completed structure. Because these situations may not be obvious to the contractor or the Erector, it is required in this Code that the Owner's Designated Representative for Design identify such situations in the Contract Documents. Similarly, if a structure is designed so that special erection techniques are required, such as jacking to impose certain loads or

position during erection, it is required in this Code that such requirements be specifically identified in the Contract Documents.

In some instances, the Owner's Designated Representative for Design may elect to show erection bracing in the Design Drawings. When this is the case, the Owner's Designated Representative for Design should then confirm that the bracing requirements were understood by review and approval of the Erection Drawings during the submittal process.

Sometimes during construction of a building, collateral building elements, such as exterior cladding, may be required to be installed on the bare Structural Steel frame prior to completion of the lateral-load-resisting system. These elements may increase the potential for lateral loads on the temporary supports. Such temporary supports may also be required to be left in place after the Structural Steel frame has been erected. Special provisions should be made by the Owner's Designated Representative for Construction for these conditions.

- 7.10.4. All temporary supports that are required for the erection operation and furnished and installed by the Erector shall remain the property of the Erector and shall not be modified, moved or removed without the consent of the Erector. Temporary supports provided by the Erector shall remain in place until the portion of the Structural Steel frame that they brace is complete and the lateral-load-resisting system and connecting diaphragm elements identified by the Owner's Designated Representative for Design in accordance with Section 7.10.1 are installed. Temporary supports that are required to be left in place after the completion of Structural Steel erection shall be removed when no longer needed by the Owner's Designated Representative for Construction and returned to the Erector in good condition.

7.11. Safety Protection

- 7.11.1. The Erector shall provide floor coverings, handrails, walkways and other safety protection for the Erector's personnel as required by law and the applicable safety regulations. Unless otherwise specified in the Contract Documents, the Erector is permitted to remove such safety protection from areas where the erection operations are completed.
- 7.11.2. When safety protection provided by the Erector is left in an area for the use of other trades after the Structural Steel erection activity is completed, the Owner's Designated Representative for Construction shall:
- (a) Accept responsibility for and maintain this protection;
 - (b) Indemnify the Fabricator and the Erector from damages that may be incurred from the use of this protection by other trades;
 - (c) Ensure that this protection is adequate for use by other affected trades;

- (d) Ensure that this protection complies with applicable safety regulations when being used by other trades; and,
- (e) Remove this protection when it is no longer required and return it to the Erector in the same condition as it was received.

7.11.3. Safety protection for other trades that are not under the direct employment of the Erector shall be the responsibility of the Owner's Designated Representative for Construction.

7.11.4. When permanent steel decking is used for protective flooring and is installed by the Owner's Designated Representative for Construction, all such work shall be scheduled and performed in a timely manner so as not to interfere with or delay the work of the Fabricator or the Erector. The sequence of installation that is used shall meet all safety regulations.

7.11.5. Unless the interaction and safety of activities of others, such as construction by others or the storage of materials that belong to others, are coordinated with the work of the Erector by the Owner's Designated Representative for Construction, such activities shall not be permitted until the erection of the Structural Steel frame or portion thereof is completed by the Erector and accepted by the Owner's Designated Representative for Construction.

7.12. Structural Steel Frame Tolerances

The accumulation of the mill tolerances and fabrication tolerances shall not cause the erection tolerances to be exceeded.

Commentary:

In previous editions of this Code, it was stated that "...variations are deemed to be within the limits of good practice when they do not exceed the cumulative effect of rolling tolerances, fabricating tolerances and erection tolerances." It is recognized in the current provision in this Section that accumulations of mill tolerances and fabrication tolerances generally occur between the locations at which erection tolerances are applied, and not at the same locations.

7.13. Erection Tolerances

Erection tolerances shall be defined relative to member working points and working lines, which shall be defined as follows:

- (a) For members other than horizontal members, the member work point shall be the actual center of the member at each end of the shipping piece.
- (b) For horizontal members, the working point shall be the actual centerline of the top flange or top surface at each end.
- (c) The member working line shall be the straight line that connects the member working points.

The substitution of other working points is permitted for ease of reference, provided they are based upon the above definitions.

The tolerances on Structural Steel erection shall be in accordance with the requirements in Sections 7.13.1 through 7.13.3.

Commentary:

The erection tolerances defined in this Section have been developed through long-standing usage as practical criteria for the erection of Structural Steel. Erection tolerances were first defined in the 1924 edition of this Code in Section 7(f), "Plumbing Up." With the changes that took place in the types and use of materials in building construction after World War II, and the increasing demand by Architects and Owners for more specific tolerances, AISC adopted new standards for erection tolerances in Section 7(h) of the March 15, 1959 edition of this Code. Experience has proven that those tolerances can be economically obtained.

Differential column shortening may be a consideration in design and construction. In some cases, it may occur due to variability in the accumulation of dead load among different columns (see Figure C-7.1). In other cases, it may be characteristic of the structural system that is employed in the design. Consideration of the effects of differential column shortening may be very important, such as when the slab thickness is reduced, when electrical and other similar fittings mounted on the Structural Steel are intended to be flush with the finished floor and when there is little clearance between bottoms of beams and the tops of door frames or ductwork.

Expansion and contraction in a Structural Steel frame may also be a consideration in the design and construction. Steel will expand or contract approximately 1/8 in. per 100 ft for each change of 15°F [2 mm per 10 000 mm for each change of 15°C] in temperature. This change in length can be assumed to act about the center of rigidity. When anchored to their foundations, end columns will be plumb only when the steel is at normal temperature (see Figure C-7.2). It is therefore necessary to correct field measurements of offsets to the structure from established baselines for the expansion or contraction of the exposed Structural Steel frame. For example, a 200-ft-long [60 000-m-long] building that is plumbed up at 100°F [38°C] should have working points at the tops of the end columns positioned 1/2 in. [14 mm] further apart than the working points at the corresponding bases in order for the columns to be plumb at 70°F [21°C]. Differential temperature effects on column length should also be taken into account in plumbing surveys when tall Structural Steel frames are subjected to sun exposure on one side.

The alignment of lintels, spandrels, wall supports and similar members that are used to connect other building construction units to the Structural Steel frame should have an adjustment of sufficient magnitude to allow for the accumulation of mill tolerances and fabrication tolerances, as well as the erection tolerances. See Figure C-7.3.

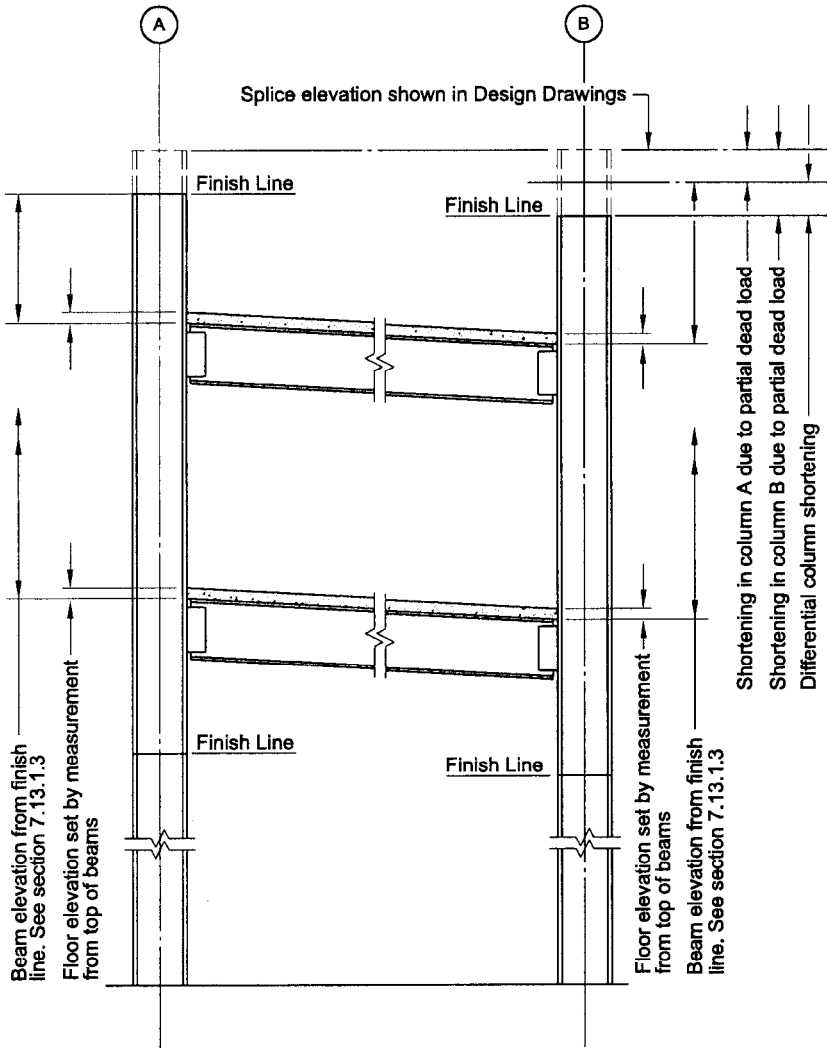

Figure C-7.1. Effects of differential column shortening.

When plumbing columns, apply a temperature adjustment at a rate of 1/8 in. per 100 ft. for each change of 15° F [2 mm per 10 000 mm for each change of 15° C] between the temperature at the time of erection and the working temperature.

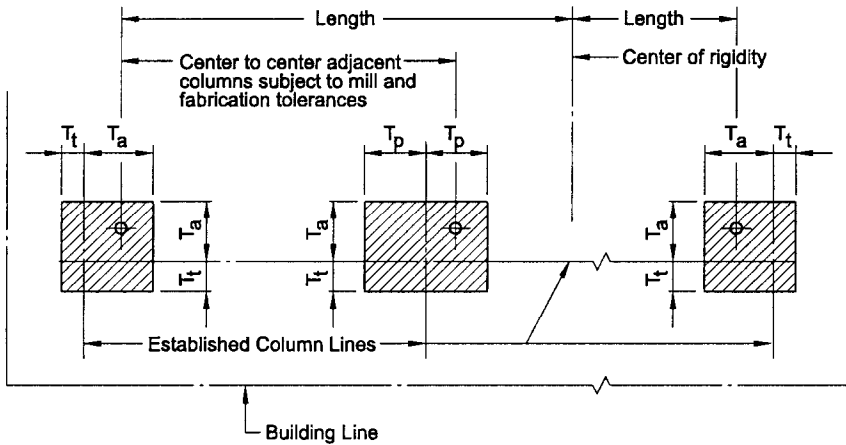
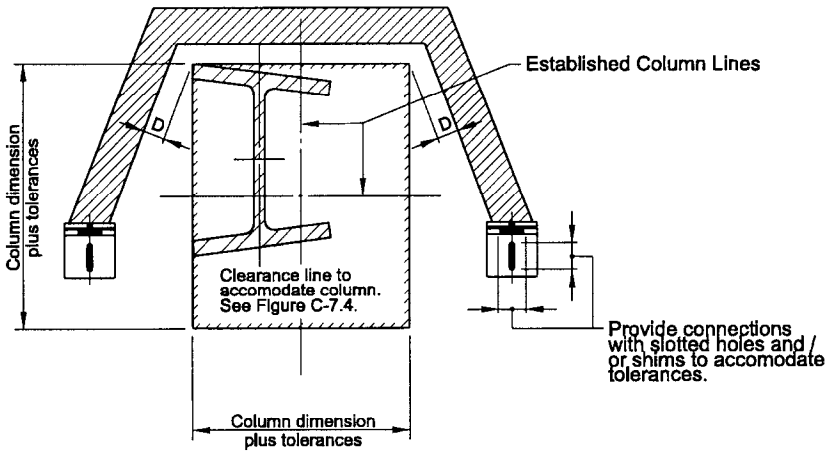

Figure C-7.2. Tolerances in plan location of column.

7.13.1. The tolerances on position and alignment of member working points and working lines shall be as described in Sections 7.13.1.1 through 7.13.1.3.

7.13.1.1. For an individual column shipping piece, the angular variation of the working line from a plumb line shall be equal to or less than 1/500 of the distance between working points, subject to the following additional limitations:

- (a) For an individual column shipping piece that is adjacent to an elevator shaft, the displacement of member working points shall be equal to or less than 1 in. [25 mm] from the Established Column Line in the first 20 stories. Above this level, an increase in the displacement of 1/32 in. [1 mm] is permitted for each additional story up to a maximum displacement of 2 in. [50 mm] from the Established Column Line.
- (b) For an exterior individual column shipping piece, the displacement of member working points from the Established Column Line in the first 20 stories shall be equal to or less than 1 in. [25 mm] toward and 2 in. [50 mm] away from the building line. Above this level, an increase in the displacement of 1/16 in. [2 mm] is permitted for each additional story up to a maximum displacement of 2 in. [50 mm] toward and 3 in. [75 mm] away from the building line.



If fascia joints are set from nearest column finish line, allow $\pm 5/8$ in. [16mm] for vertical adjustment. The entity responsible for the fascia details must allow for progressive shortening of steel columns.

D= Tolerances required by manufacturer of wall units plus survey tolerances.

Figure C-7.3. Clearance required to accommodate fascia.

Commentary:

The limitations that are described in this Section and illustrated in Figures C-7.4 and C-7.5 make it possible to maintain built-in-place or prefabricated facades in a true vertical plane up to the 20th story, if Connections that provide for 3 in. [75 mm] of adjustment are used. Above the 20th story, the facade may be maintained within 1/16 in. [2 mm] per story with a maximum total deviation of 1 in. [25 mm] from a true vertical plane, if Connections that provide for 3 in. [75 mm] of adjustment are used. Connections that permit adjustments of plus 2 in. [50 mm] to minus 3 in. [75 mm] (5 in. [125 mm] total) will be necessary in cases where it is desired to construct the facade to a true vertical plane above the 20th story.

- (c) For an exterior individual column shipping piece, the member working points at any splice level for multi-Tier buildings and at the tops of columns for single-Tier buildings shall fall within a horizontal envelope, parallel to the building line, that is equal to or less than 1 1/2 in. [38 mm] wide for buildings up to 300 ft [90 000 mm] in length. An increase in the width of

this horizontal envelope of 1/2 in. [13 mm] is permitted for each additional 100 ft [30 000 m] in length up to a maximum width of 3 in. [75 mm].

Commentary:

This Section limits the position of exterior column working points at any given splice elevation to a narrow horizontal envelope parallel to the building line (see Figure C-7.6). This envelope is limited to a width of 1 1/2 in. [38 mm], normal to the building line, in up to 300 ft [90 000 mm] of building length. The horizontal location of this envelope is not necessarily directly above or below the corresponding envelope at the adjacent splice elevations, but should be within the limitation of the 1 in 500 plumbness tolerance specified for the controlling columns (see Figure C-7.5).

- (d) For an exterior column shipping piece, the displacement of member working points from the Established Column Line, parallel to the building line, shall be equal to or less than 2 in. [50 mm] in the first 20 stories. Above this level, an increase in the displacement of 1/16 in. [2 mm] is permitted for each additional story up to a maximum displacement of 3 in. [75 mm] parallel to the building line.

7.13.1.2. For members other than column shipping pieces, the following limitations shall apply:

- (a) For a member that consists of an individual, straight shipping piece without field splices, other than a cantilevered member, the variation in alignment shall be acceptable if it is caused solely by variations in column alignment and/or primary supporting member alignment that are within the permissible variations for the fabrication and erection of such members.
- (b) For a member that consists of an individual, straight shipping piece that connects to a column, the variation in the distance from the member working point to the upper finished splice line of the column shall be equal to or less than plus 3/16 in. [5 mm] and minus 5/16 in. [8 mm].
- (c) For a member that consists of an individual shipping piece that does not connect to a column, the variation in elevation shall be acceptable if it is caused solely by the variations in the elevations of the supporting members within the permissible variations for the fabrication and erection of those members.
- (d) For a member that consists of an individual, straight shipping piece and that is a segment of a field assembled unit containing field splices between points of support, the plumbness, elevation and alignment shall be acceptable if the angular variation of the working line from the plan alignment is equal to or less than 1/500 of the distance between working points.

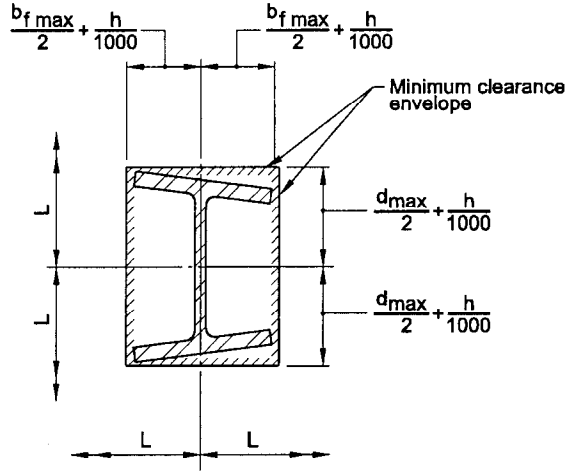

For enclosures or attachments that may follow column alignment.

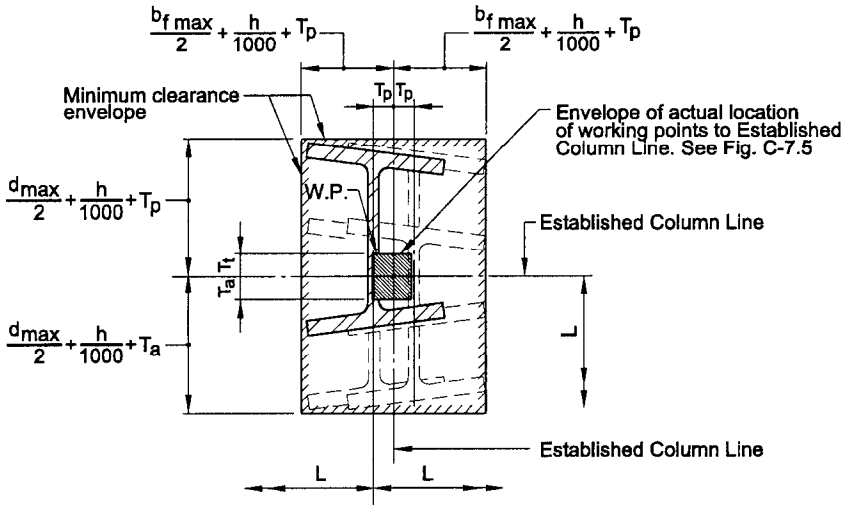

For enclosures or attachments that must be held to precise plan location.

L = Actual center to center of columns = plan dimensions \pm column cross section tolerance of columns \pm beam length tolerance.

T_a = Plumbness tolerance away from building line (varies, see Fig. C-7.5)

T_t = Plumbness tolerance toward building line (varies, see Fig. C-7.5)

T_p = Plumbness tolerance parallel to building line ($=T_a$)

Figure C-7.4. Clearance required to accommodate accumulated column tolerance.

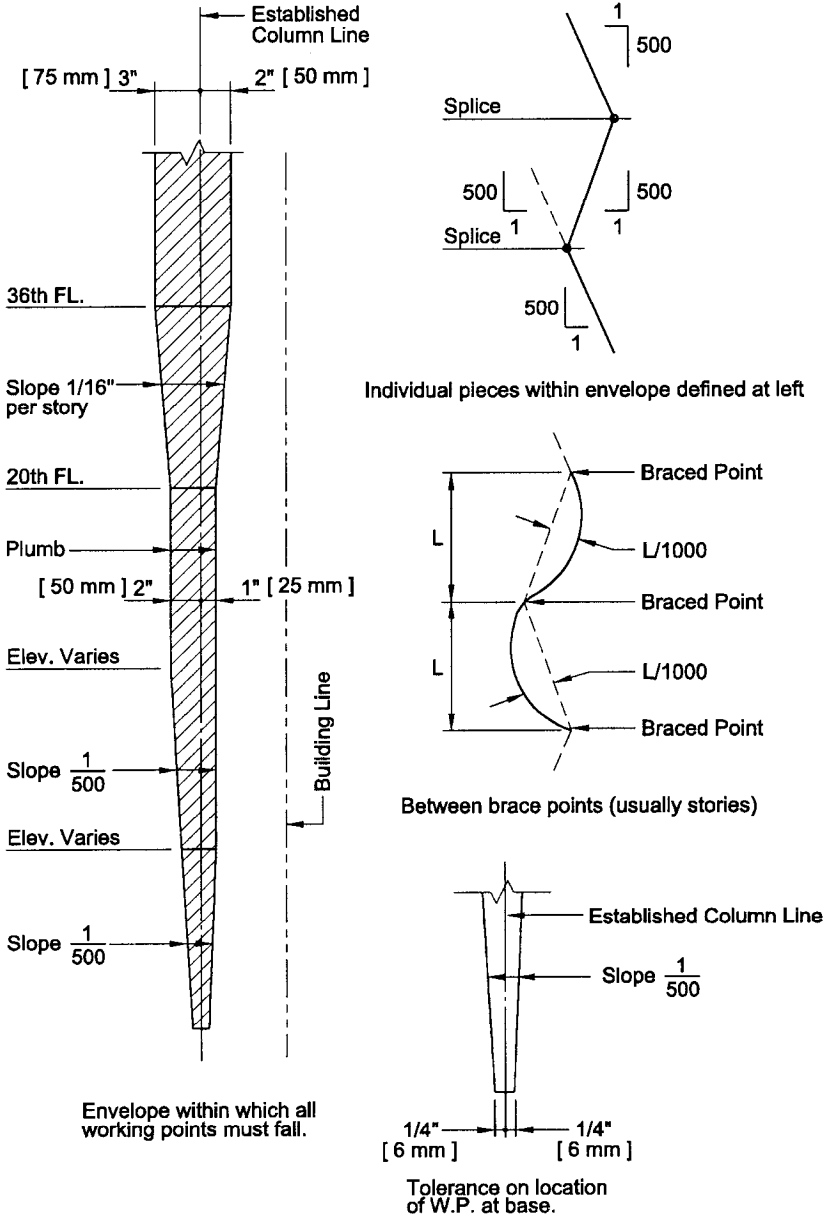

Note: The plumb line through the base working point for an individual column is not necessarily the precise plan location because Sect. 7.13.1.1 deals only with plumbness tolerances and does not include inaccuracies in location of the Established Column Line, foundations and anchor rods beyond the Erector's control

Figure C-7.5. Exterior column plumbness tolerances normal to building line.

Code of Standard Practice for Steel Buildings and Bridges, March 18, 2005

AMERICAN INSTITUTE OF STEEL CONSTRUCTION

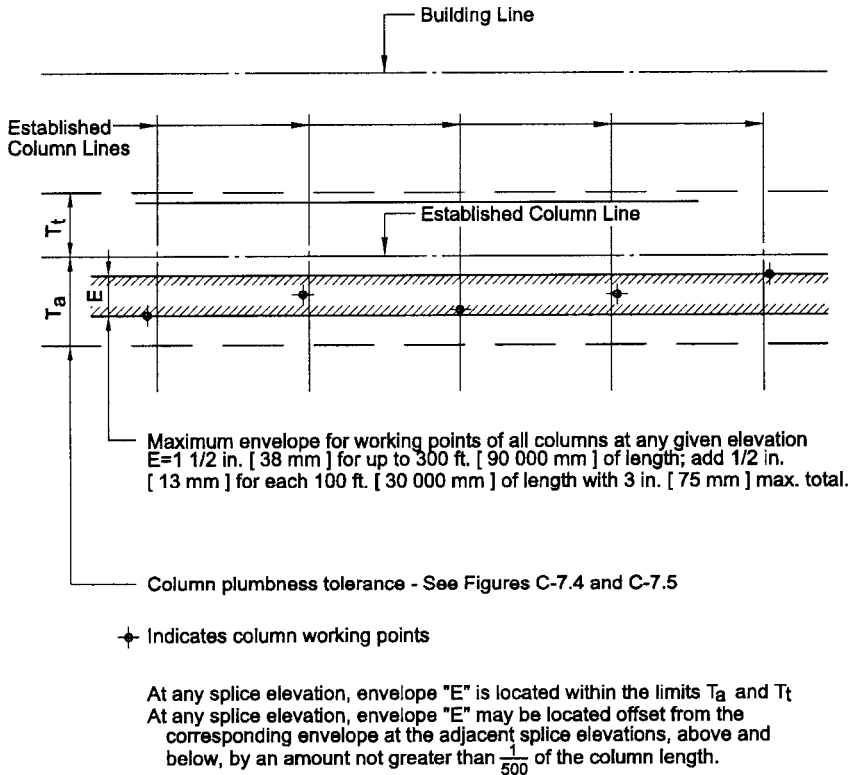

Figure C-7.6. Tolerances in plan at any splice elevation of exterior columns.

- (e) For a cantilevered member that consists of an individual, straight shipping piece, the plumbness, elevation and alignment shall be acceptable if the angular variation of the working line from a straight line that is extended in the plan direction from the working point at its supported end is equal to or less than $1/500$ of the distance from the working point at the free end.
- (f) For a member of irregular shape, the plumbness, elevation and alignment shall be acceptable if the fabricated member is within its tolerances and the members that support it are within the tolerances specified in this Code.

Commentary:

The angular misalignment of the working line of all fabricated shipping pieces relative to the line between support points of the member as a whole in erected position must not exceed 1 in 500. Note that the tolerance is not stated in terms of a linear displacement at any point and is not to be taken as the overall length between supports divided by 500. Typical examples are

shown in Figure C-7.7. Numerous conditions within tolerance for these and other cases are possible. This condition applies to both plan and elevation tolerances.

- (g) For a member that is fully assembled in the field in an unstressed condition, the same tolerances shall apply as if fully assembled in the shop.
- (h) For a member that is field-assembled, element-by-element in place, temporary support shall be used or an alternative erection plan shall be submitted to the Owner's Designated Representatives for Design and Construction. The tolerance in Section 7.13.1.2(d) shall be met in the supported condition with working points taken at the point(s) of temporary support.

Commentary:

Trusses fabricated and erected as a unit or as an assembly of truss segments normally have excellent controls on vertical position regardless of fabrication and erection techniques. However, a truss fabricated and erected by assembling individual components in place in the field is potentially more sensitive to deflections of the individual truss components and the partially completed work during erection, particularly the chord members. In such a case, the erection process should follow an erection plan that addresses this issue.

7.13.1.3. For members that are identified as Adjustable Items by the Owner's Designated Representative for Design in the Contract Documents, the Fabricator shall provide adjustable Connections for these members to the supporting Structural Steel frame. Otherwise, the Fabricator is permitted to provide non-adjustable Connections. When Adjustable Items are specified, the Owner's Designated Representative for Design shall indicate the total adjustability that is required for the proper alignment of these supports for other trades. The variation in the position and alignment of Adjustable Items shall be as follows:

- (a) The variation in the vertical distance from the upper finished splice line of the nearest column to the support location specified in the structural Design Drawings shall be equal to or less than plus or minus 3/8 in. [10 mm].
- (b) The variation in the horizontal distance from the established finish line at the particular floor shall be equal to or less than plus or minus 3/8 in. [10 mm].
- (c) The variation in vertical and horizontal alignment at the abutting ends of Adjustable Items shall be equal to or less than plus or minus 3/16 in. [5 mm].

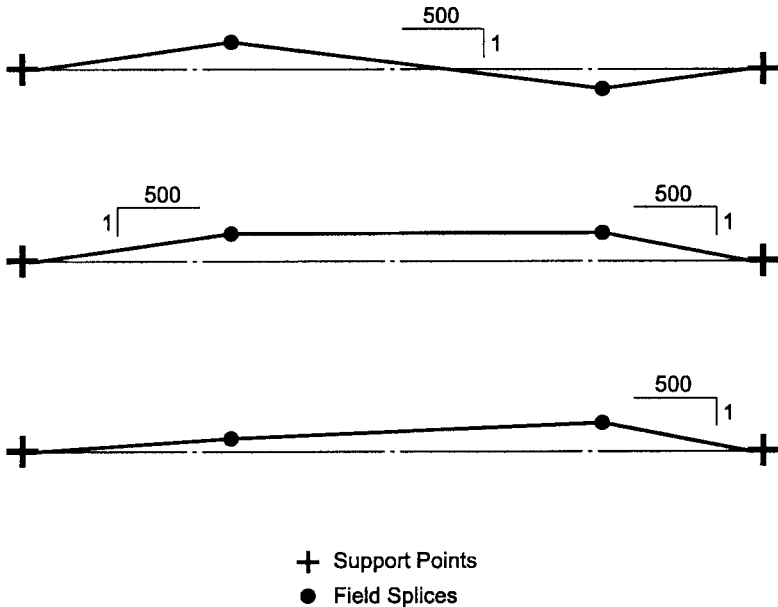

Figure C-7.7. Alignment tolerances for members with field splices.

Commentary:

When the alignment of lintels, wall supports, curb angles, mullions and similar supporting members for the use of other trades is required to be closer than that permitted by the foregoing tolerances for Structural Steel, the Owner's Designated Representative for Design must identify such items in the Contract Documents as Adjustable Items.

- 7.13.2. In the design of steel structures, the Owner's Designated Representative for Design shall provide for the necessary clearances and adjustments for material furnished by other trades to accommodate the mill tolerances, fabrication tolerances and erection tolerances in this Code for the Structural Steel frame.

Commentary:

In spite of all efforts to minimize inaccuracies, deviations will still exist; therefore, in addition, the designs of prefabricated wall panels, partition panels, fenestrations, floor-to-ceiling door frames and similar elements must provide for clearance and details for adjustment as described in Section 7.13.2. Designs must provide for adjustment in the vertical dimension of prefabricated facade panels that are supported by the Structural Steel frame because the accumulation of shortening of loaded steel columns will result in the unstressed facade supported at each floor level being higher than the Structural Steel framing to

which it must be attached. Observations in the field have shown that where a heavy facade is erected to a greater height on one side of a multistory building than on the other, the Structural Steel framing will be pulled out of alignment. Facades should be erected at a relatively uniform rate around the perimeter of the structure.

- 7.13.3. Prior to placing or applying any other materials, the Owner's Designated Representative for Construction shall determine that the location of the Structural Steel is acceptable for plumbness, elevation and alignment. The Erector shall be given either timely notice of acceptance by the Owner's Designated Representative for Construction, or a listing of specific items that are to be corrected in order to obtain acceptance. Such notice shall be rendered promptly upon completion of any part of the work and prior to the start of work by other trades that may be supported, attached or applied to the Structural Steel frame.

7.14. Correction of Errors

The correction of minor misfits by moderate amounts of reaming, grinding, welding or cutting, and the drawing of elements into line with drift pins, shall be considered to be normal erection operations. Errors that cannot be corrected using the foregoing means, or that require major changes in member or Connection configuration, shall be promptly reported to the Owner's Designated Representatives for Design and Construction and the Fabricator by the Erector, to enable the responsible entity to either correct the error or approve the most efficient and economical method of correction to be used by others.

Commentary:

As used in this Section, the term "moderate" refers to the amount of reaming, grinding, welding or cutting that must be done on the project as a whole, not the amount that is required at an individual location. It is not intended to address limitations on the amount of material that is removed by reaming at an individual bolt hole, for example, which is limited by the bolt-hole size and tolerance requirements in the AISC and RCSC Specifications.

7.15. Cuts, Alterations and Holes for Other Trades

Neither the Fabricator nor the Erector shall cut, drill or otherwise alter their work, nor the work of other trades, to accommodate other trades, unless such work is clearly specified in the Contract Documents. When such work is so specified, the Owner's Designated Representatives for Design and Construction shall furnish complete information as to materials, size, location and number of alterations in a timely manner so as not to delay the preparation of Shop and Erection Drawings.

7.16. Handling and Storage

The Erector shall take reasonable care in the proper handling and storage of the Structural Steel during erection operations to avoid the accumulation of excess

dirt and foreign matter. The Erector shall not be responsible for the removal from the Structural Steel of dust, dirt or other foreign matter that may accumulate during erection as the result of job-site conditions or exposure to the elements. The Erector shall handle and store all bolts, nuts, washers and related fastening products in accordance with the requirements of the RCSC Specification.

Commentary:

During storage, loading, transport, unloading and erection, blemish marks caused by slings, chains, blocking, tie-downs, etc., occur in varying degrees. Abrasions caused by handling or cartage after painting are to be expected. It must be recognized that any shop-applied coating, no matter how carefully protected, will require touching-up in the field. Touching-up of these blemished areas is the responsibility of the contractor performing the field touch-up or field painting.

The Erector is responsible for the proper storage and handling of fabricated Structural Steel at the job site during erection. Shop-painted Structural Steel that is stored in the field pending erection should be kept free of the ground and positioned so as to minimize the potential for water retention. The Owner or Owner's Designated Representative for Construction is responsible for providing suitable job-site conditions and proper access so that the Fabricator/Erector may perform its work.

Job-site conditions are frequently muddy, sandy, dusty or a combination thereof during the erection period. Under such conditions it may be impossible to store and handle the Structural Steel in such a way as to completely avoid any accumulation of mud, dirt or sand on the surface of the Structural Steel, even though the Fabricator and the Erector manages to proceed with their work.

Repairs of damage to painted surfaces and/or removal of foreign materials due to adverse job-site conditions are outside the scope of responsibility of the Fabricator and the Erector when reasonable attempts at proper handling and storage have been made.

7.17. Field Painting

Neither the Fabricator nor the Erector is responsible to paint field bolt heads and nuts or field welds, nor to touch up abrasions of the shop coat, nor to perform any other field painting.

7.18. Final Cleaning Up

Upon the completion of erection and before final acceptance, the Erector shall remove all of the Erector's falsework, rubbish and temporary buildings.

SECTION 8. QUALITY ASSURANCE

8.1. General

- 8.1.1. The Fabricator shall maintain a quality assurance program to ensure that the work is performed in accordance with the requirements in this Code, the AISC Specification and the Contract Documents. The Fabricator shall have the option to use the AISC Quality Certification Program to establish and administer the quality assurance program.

Commentary:

The AISC Quality Certification Program confirms to the construction industry that a certified Structural Steel fabrication shop has the capability by reason of commitment, personnel, organization, experience, procedures, knowledge and equipment to produce fabricated Structural Steel of the required quality for a given category of work. The AISC Quality Certification Program is not intended to involve inspection and/or judgment of product quality on individual projects. Neither is it intended to guarantee the quality of specific fabricated Structural Steel products.

- 8.1.2. The Erector shall maintain a quality assurance program to ensure that the work is performed in accordance with the requirements in this Code, the AISC Specification and the Contract Documents. The Erector shall be capable of performing the erection of the Structural Steel, and shall provide the equipment, personnel and management for the scope, magnitude and required quality of each project. The Erector shall have the option to use the AISC Erector Certification Program to establish and administer the quality assurance program.

Commentary:

The AISC Erector Certification Program confirms to the construction industry that a certified Structural Steel Erector has the capability by reason of commitment, personnel, organization, experience, procedures, knowledge and equipment to erect fabricated Structural Steel to the required quality for a given category of work. The AISC Erector Certification Program is not intended to involve inspection and/or judgment of product quality on individual projects. Neither is it intended to guarantee the quality of specific erected Structural Steel products.

- 8.1.3. When the Owner requires more extensive quality assurance or independent inspection by qualified personnel, or requires that the Fabricator be certified under the AISC Quality Certification Program and/or requires that the Erector be certified under the AISC Erector Certification Program, this shall be clearly stated in the Contract Documents, including a definition of the scope of such inspection.

8.2. Inspection of Mill Material

Certified mill test reports shall constitute sufficient evidence that the mill product satisfies material order requirements. The Fabricator shall make a visual inspection of material that is received from the mill, but need not perform any material tests unless the Owner's Designated Representative for Design specifies in the Contract Documents that additional testing is to be performed at the Owner's expense.

8.3. Non-Destructive Testing

When non-destructive testing is required, the process, extent, technique and standards of acceptance shall be clearly specified in the Contract Documents.

8.4. Surface Preparation and Shop Painting Inspection

Inspection of surface preparation and shop painting shall be planned for the acceptance of each operation as the Fabricator completes it. Inspection of the paint system, including material and thickness, shall be made promptly upon completion of the paint application. When wet-film thickness is to be inspected, it shall be measured during the application.

8.5. Independent Inspection

When inspection by personnel other than those of the Fabricator and/or Erector is specified in the Contract Documents, the requirements in Sections 8.5.1 through 8.5.6 shall be met.

- 8.5.1. The Fabricator and the Erector shall provide the Inspector with access to all places where the work is being performed. A minimum of 24 hours notification shall be given prior to the commencement of work.
- 8.5.2. Inspection of shop work by the Inspector shall be performed in the Fabricator's shop to the fullest extent possible. Such inspections shall be timely, in-sequence and performed in such a manner as will not disrupt fabrication operations and will permit the repair of non-conforming work prior to any required painting while the material is still in-process in the fabrication shop.
- 8.5.3. Inspection of field work shall be promptly completed without delaying the progress or correction of the work.
- 8.5.4. Rejection of material or workmanship that is not in conformance with the Contract Documents shall be permitted at any time during the progress of the work. However, this provision shall not relieve the Owner or the Inspector of the obligation for timely, in-sequence inspections.

- 8.5.5. The Fabricator, Erector, and Owner's Designated Representatives for Design and Construction shall be informed of deficiencies that are noted by the Inspector promptly after the inspection. Copies of all reports prepared by the Inspector shall be promptly given to the Fabricator, Erector and Owner's Designated Representatives for Design and Construction. The necessary corrective work shall be performed in a timely manner.
- 8.5.6. The Inspector shall not suggest, direct, or approve the Fabricator or Erector to deviate from the Contract Documents or the approved Shop and Erection Drawings, or approve such deviation, without the written approval of the Owner's Designated Representatives for Design and Construction.

SECTION 9. CONTRACTS

9.1. Types of Contracts

- 9.1.1. For contracts that stipulate a lump sum price, the work that is required to be performed by the Fabricator and the Erector shall be completely defined in the Contract Documents.
- 9.1.2. For contracts that stipulate a price per pound, the scope of work that is required to be performed by the Fabricator and the Erector, the type of materials, the character of fabrication and the conditions of erection shall be based upon the Contract Documents, which shall be representative of the work to be performed.
- 9.1.3. For contracts that stipulate a price per item, the work that is required to be performed by the Fabricator and the Erector shall be based upon the quantity and the character of the items that are described in the Contract Documents.
- 9.1.4. For contracts that stipulate unit prices for various categories of Structural Steel, the scope of work that is required to be performed by the Fabricator and the Erector shall be based upon the quantity, character and complexity of the items in each category as described in the Contract Documents, and shall also be representative of the work to be performed in each category.

9.2. Calculation of Weights

Unless otherwise specified in the contract, for contracts stipulating a price per pound for fabricated Structural Steel that is delivered and/or erected, the quantities of materials for payment shall be determined by the calculation of the gross weight of materials as shown in the Shop Drawings.

Commentary:

The standard procedure for calculation of weights that is described in this Code meets the need for a universally acceptable system for defining “pay weights” in contracts based upon the weight of delivered and/or erected materials. These procedures permits the Owner to easily and accurately evaluate price-per-pound proposals from potential suppliers and enables all parties to a contract to have a clear and common understanding of the basis for payment.

The procedure in this Code affords a simple, readily understood method of calculation that will produce pay weights that are consistent throughout the industry and that may be easily verified by the Owner. While this procedure does not produce actual weights, it can be used by purchasers and suppliers to define a widely accepted basis for bidding and contracting for Structural Steel. However, any other system can be used as the basis for a contractual agreement. When other systems are used, both the supplier and the purchaser should clearly understand how the alternative procedure is handled.

- 9.2.1. The unit weight of steel shall be taken as 490 lb/ft³ [7 850 kg/m³]. The unit weight of other materials shall be in accordance with the manufacturer's published data for the specific product.
- 9.2.2. The weights of Standard Structural Shapes, plates and bars shall be calculated on the basis of Shop Drawings that show the actual quantities and dimensions of material to be fabricated, as follows:
- (a) The weights of all Standard Structural Shapes shall be calculated using the nominal weight per ft [mass per m] and the detailed overall length.
 - (b) The weights of plates and bars shall be calculated using the detailed overall rectangular dimensions.
 - (c) When parts can be economically cut in multiples from material of larger dimensions, the weight shall be calculated on the basis of the theoretical rectangular dimensions of the material from which the parts are cut.
 - (d) When parts are cut from Standard Structural Shapes, leaving a non-standard section that is not useable on the same contract, the weight shall be calculated using the nominal weight per ft [mass per m] and the overall length of the Standard Structural Shapes from which the parts are cut.
 - (e) Deductions shall not be made for material that is removed for cuts, copes, clips, blocks, drilling, punching, boring, slot milling, planing or weld joint preparation.
- 9.2.3. The items for which weights are shown in tables in the AISC Manual of Steel Construction shall be calculated on the basis of the tabulated weights shown therein.
- 9.2.4. The weights of items that are not shown in tables in the AISC Manual of Steel Construction shall be taken from the manufacturer's catalog and the manufacturer's shipping weight shall be used.

Commentary:

Many items that are weighed for payment purposes are not tabulated with weights in the AISC Manual of Steel Construction. These include, but are not limited to, Anchor Rods, clevises, turnbuckles, sleeve nuts, recessed-pin nuts, cotter pins and similar devices.

- 9.2.5. The weights of shop or field weld metal and protective coatings shall not be included in the calculated weight for the purposes of payment.

9.3. Revisions to the Contract Documents

Revisions to the Contract Documents shall be confirmed by change order or extra work order. Unless otherwise noted, the issuance of a revision to the

Contract Documents shall constitute authorization by the Owner that the revision is Released for Construction. The contract price and schedule shall be adjusted in accordance with Sections 9.4 and 9.5.

9.4. Contract Price Adjustment

- 9.4.1. When the scope of work and responsibilities of the Fabricator and the Erector are changed from those previously established in the Contract Documents, an appropriate modification of the contract price shall be made. In computing the contract price adjustment, the Fabricator and the Erector shall consider the quantity of work that is added or deleted, the modifications in the character of the work and the timeliness of the change with respect to the status of material ordering, detailing, fabrication and erection operations.

Commentary:

The fabrication and erection of Structural Steel is a dynamic process. Typically, material is being acquired at the same time that the Shop and Erection Drawings are being prepared. Additionally, the fabrication shop will normally fabricate pieces in the order that the Structural Steel is being shipped and erected.

Items that are revised or placed on hold generally upset these relationships and can be very disruptive to the detailing, fabricating and erecting processes. The provisions in Sections 3.5, 4.4.2 and 9.3 are intended to minimize these disruptions so as to allow work to continue. Accordingly, it is required in this Code that the reviewer of requests for contract price adjustments recognize this and allow compensation to the Fabricator and the Erector for these inefficiencies and for the materials that are purchased and the detailing, fabrication and erection that has been performed, when affected by the change.

- 9.4.2. Requests for contract price adjustments shall be presented by the Fabricator and/or the Erector in a timely manner and shall be accompanied by a description of the change that is sufficient to permit evaluation and timely approval by the Owner.
- 9.4.3. Price-per-pound and price-per-item contracts shall provide for additions or deletions to the quantity of work that are made prior to the time the work is Released for Construction. When changes are made to the character of the work at any time, or when additions and/or deletions are made to the quantity of the work after it is released for detailing, fabrication or erection, the contract price shall be equitably adjusted.

9.5. Scheduling

- 9.5.1. The contract schedule shall state when the Design Drawings will be Released for Construction, if the Design Drawings are not available at the time of

bidding, and when the job site, foundations, piers and abutments will be ready, free from obstructions and accessible to the Erector, so that erection can start at the designated time and continue without interference or delay caused by the Owner's Designated Representative for Construction or other trades.

- 9.5.2. The Fabricator and the Erector shall advise the Owner's Designated Representatives for Design and Construction, in a timely manner, of the effect any revision has on the contract schedule.
- 9.5.3. If the fabrication or erection is significantly delayed due to revisions to the requirements of the contract, or for other reasons that are the responsibility of others, the Fabricator and/or Erector shall be compensated for the additional costs incurred.

9.6. Terms of Payment

The Fabricator shall be paid for Mill Materials and fabricated product that is stored off the job site. Other terms of payment for the contract shall be outlined in the Contract Documents.

Commentary:

These terms include such items as progress payments for material, fabrication, erection, retainage, performance and payment bonds and final payment. If a performance or payment bond, paid for by the Owner, is required by contract, no retainage shall be required.

SECTION 10. ARCHITECTURALLY EXPOSED STRUCTURAL STEEL

10.1. General Requirements

When members are specifically designated as “Architecturally Exposed Structural Steel” or “AESS” in the Contract Documents, the requirements in Sections 1 through 9 shall apply as modified in Section 10. AESS members or components shall be fabricated and erected with the care and dimensional tolerances that are stipulated in Sections 10.2 through 10.4. The following additional information shall be provided in the Contract Documents when AESS is specified:

- (a) Specific identification of members or components that are AESS;
- (b) Fabrication and/or erection tolerances that are to be more restrictive than provided for in this Section, if any; and,
- (c) Requirements, if any, of a mock-up panel or components for inspection and acceptance standards prior to the start of fabrication.

Commentary:

This Section of this Code defines additional requirements that apply only to members that are specifically designated by the Contract Documents as “Architecturally Exposed Structural Steel” (AESS). The rapidly increasing use of exposed Structural Steel as a medium of architectural expression has given rise to a demand for closer dimensional tolerances and smoother finished surfaces than required for ordinary Structural Steel framing.

This Section of this Code establishes standards for these requirements that take into account both the desired finished appearance and the abilities of the fabrication shop to produce the desired product. It should be pointed out that the term “Architecturally Exposed Structural Steel” (AESS), as covered in this Section, must be specified in the Contract Documents if the Fabricator is required to meet the fabricating standards in this Section, and applies only to that portion of the Structural Steel so identified.

AESS requirements usually involve significant cost in excess of that for Structural Steel that is fabricated in the absence of an AESS requirement. Therefore, the designation AESS should be applied rationally, with visual acceptance criteria that are appropriate for the distance at which the exposed element will be viewed in the completed structure. In order to avoid misunderstandings and to hold costs to a minimum, only those Structural Steel surfaces and Connections that will remain exposed and subject to normal view by pedestrians or occupants of the completed structure should be designated as AESS.

10.2. Fabrication

- 10.2.1. The permissible tolerances for out-of-square or out-of-parallel, depth, width and symmetry of rolled shapes shall be as specified in ASTM A6/A6M. Unless

otherwise specified in the Contract Documents, the exact matching of abutting cross-sectional configurations shall not be necessary. The as-fabricated straightness tolerances of members shall be one-half of the standard camber and sweep tolerances in ASTM A6/A6M.

- 10.2.2. The tolerances on overall profile dimensions of members that are built-up from a series of Standard Structural Shapes, plates and/or bars by welding shall be taken as the accumulation of the variations that are permitted for the component parts in ASTM A6/A6M. The as-fabricated straightness tolerances for the member as a whole shall be one-half the standard camber and sweep tolerances for rolled shapes in ASTM A6/A6M.
- 10.2.3. Unless specific visual acceptance criteria for Weld Show-Through are specified in the Contract Documents, the members or components shall be acceptable as produced.

Commentary:

Weld Show-Through is generally a function of weld size and material thickness.

- 10.2.4. All copes, miters and cuts in surfaces that are exposed to view shall be made with uniform gaps of 1/8 in. [3 mm] if shown as open joints, or in reasonable contact if shown without gap.
- 10.2.5. All welds that are exposed to view shall be visually acceptable if they meet the requirements in AWS D1.1, except all groove and plug welds that are exposed to view shall not project more than 1/16 in. [2 mm] above the exposed surface. Finishing or grinding of welds shall not be necessary, unless such treatment is required to provide for clearances or fit of other components.
- 10.2.6. Erection marks or other painted marks shall not be made on those surfaces of weathering steel AESS members that are to be exposed in the completed structure. Unless otherwise specified in the Contract Documents, the Fabricator shall clean weathering steel AESS members to meet the requirements of SSPC-SP6.
- 10.2.7. Stamped or raised manufacturer's identification marks shall not be filled, ground or otherwise removed.
- 10.2.8. Seams of hollow structural sections shall be acceptable as produced. Seams shall be oriented away from view or as directed in the Contract Documents.

10.3. Delivery of Materials

The Fabricator shall use special care to avoid bending, twisting or otherwise distorting the Structural Steel.

10.4. Erection

- 10.4.1. The Erector shall use special care in unloading, handling and erecting the Structural Steel to avoid marking or distorting the Structural Steel. Care shall also be taken to minimize damage to any shop paint. If temporary braces or erection clips are used, care shall be taken to avoid the creation of unsightly surfaces upon removal. Tack welds shall be ground smooth and holes shall be filled with weld metal or body solder and smoothed by grinding or filing. The Erector shall plan and execute all operations in such a manner that the close fit and neat appearance of the structure will not be impaired.
- 10.4.2. Unless otherwise specified in the Contract Documents, AESS members and components shall be plumbed, leveled and aligned to a tolerance that is one-half that permitted for non-AESS members. To accommodate these erection tolerances for AESS, the Owner's Designated Representative for Design shall specify Connections between AESS members and non-AESS members, masonry, concrete and other supports as Adjustable Items, in order to provide the Erector with means for adjustment.
- 10.4.3. When AESS is backed with concrete, the Owner's Designated Representative for Construction shall provide sufficient shores, ties and strongbacks to prevent sagging, bulging or similar deformation of the AESS members due to the weight and pressure of the wet concrete.

APPENDIX A. DIGITAL BUILDING PRODUCT MODELS

The provisions in this Appendix shall apply when the contract documents indicate that a three-dimensional digital building product model replaces contract drawings and is to be used as the primary means of designing, representing, and exchanging structural steel data for the project. When this is the case, all references to the Design Drawings in this Code shall instead apply to the Design Model, and all references to the Shop and Erection Drawings in the Code shall instead apply to the Manufacturing Model. The CIS/2 Logical Product Model shall be used as the building product model for structural steel.

If the primary means of project communication reverts from a model-based system to a paper-based system, the requirements in this Code other than in this Appendix shall apply.

Commentary:

Current technology permits the transfer of three-dimensional digital building product model data among the design and construction teams for a project. Over the last several years, designers and fabricators have used CIS/2 as a standard format in the exchange of building product models representing the steel structure. This Appendix facilitates the use of this technology in the design and construction of steel structures, and eliminates any interpretation of this Code that might be construed to prohibit or inhibit the use of this technology. While the technology is new and there is no long-established standard of practice, it is the intent in this Appendix to provide guidance for its use.

APPENDIX A. GLOSSARY

Add the following definitions to the Glossary:

Building Product Model. A digital information structure of the objects making up a building, capturing the form, function, behavior and relations of the parts and assemblies within one or more building systems. A building product model can be implemented in multiple ways, including as an ASCII file or as a database. The data in the model is created, manipulated, evaluated, reviewed and presented using computer-based design, engineering, and manufacturing applications. Traditional two-dimensional drawings may be one of many reports generated by the building product model (see Eastman, Charles M.: *Building Product Models: Computer Environments Supporting Design and Construction*; 1999 by CRC Press).

CIS/2 (CIMSteel Integration Standards/Version 2). The specification providing the building product model for structural steel and format for electronic data interchange (EDI) among software applications dealing with steel design, analysis, and manufacturing.

Logical Product Model (LPM). The CIS/2 building product model, which supports the engineering of low-, medium- and high-rise construction, in domestic, commercial

and industrial contexts. All elements of the structure are covered, including main and secondary framing and connections. The components used can be of any variety of structural shape or element.

The LPM addresses the exchange of data between structural steel applications. It is meant to support a heterogeneous set of applications over a fairly broad portion of the steel lifecycle. It is organized around three different sub-models: the Analysis Model (data represented in structural analysis), the Design Model (data represented in frame design layout) and the Manufacturing Model (data represented in detailing for fabrication).

Data Management Conformance (DMC). The capability of the CIMSteel model to include optional data entities for managing and tracking additions, deletions and modifications to a model, including who made the change and when the change was made for all data changes.

A1.2. Referenced Specifications, Codes and Standards

Add the following reference to Section 1.2:

CIMSteel Integration Standards Release 2: Second Edition P265: CIS/2.1: Volumes 1 through 4.

A3. DESIGN DRAWINGS AND SPECIFICATIONS

In addition to the requirements in Section 3, the following requirements shall apply to the Design Model:

A3.1. Design Model

The Design Model shall:

- (a) Consist of Data Management Conformance Classes.
- (b) Contain Analysis Model data so as to include load calculations as specified in the Contract Documents.
- (c) Include entities that fully define each steel element and the extent of detailing of each element, as would be recorded on equivalent set of structural steel design drawings.
- (d) Include all steel elements identified in the Contract Documents as well as any other entities required for strength and stability of the completely erected structure.
- (e) Govern over all other forms of information, including drawings, sketches, etc.

A3.2. LPM Administration

The Owner shall designate an Administrator for the LPM, who shall:

- (a) Control the LPM by providing appropriate access privileges (read, write, etc) to all relevant parties.
- (b) Maintain the security of the LPM.
- (c) Guard against data loss of the LPM.
- (d) Be responsible for updates and revisions to the LPM as they occur.
- (e) Inform all appropriate parties as to changes to the LPM.

Commentary:

When a project is designed and constructed using EDI, it is imperative that an individual entity on the team be responsible for maintaining the LPM. This is to assure protection of data through proper backup, storage and security and to provide coordination of the flow of information to all team members when information is added to the model. Team members exchange information to revise the model with this Administrator. The Administrator will validate all changes to the LPM. This is to assure proper tracking and control of revisions.

This Administrator can be one of the design team members such as an Architect, Structural Engineer or a separate entity on the design team serving this purpose. The Administrator can also be the Fabricator's detailer or a separate entity on the construction team serving this purpose.

A4.3. Fabricator Responsibility

In addition to the requirements in Section 4.3, the following requirements shall apply:

When the Design Model is used to develop the Manufacturing Model the fabricator shall accept the information under the following conditions:

- (a) When the design information is to be conveyed to the Fabricator by way of the Design Model, in the event of a conflict between the model and the Design Drawings, the Design Model will control.
- (b) The ownership of the information added to the LPM in the Manufacturing Model should be defined in the Contract Documents. In the absence of terms for ownership regarding the information added by the Fabricator to the LPM in the Contract Documents, the ownership will belong to the Fabricator.
- (c) During the development of the Manufacturing Model, as member locations are adjusted to convert the modeled parts from a Design Model, these relocations will only be done with the approval of the Owner's Designated Representative for Design.
- (d) The Fabricator and Erector shall accept the use of the LPM and Design Model under the same conditions as set forth in Paragraph 4.3 with regard to CAD files, except as modified in A4.3 above.

A4.4. Approval

In addition to the requirements in Section 4.4, the following requirements shall apply:

When the approval of the detailed material is to be done by the use of the Manufacturing Model the version of the submitted model shall be identified. The approver shall annotate the Manufacturing Model with approval comments attached to the individual elements as specified in the CIS/2 standard. As directed by the approval comment the Fabricator will reissue the Manufacturing Model for re-review and the version of the model submitted will be tracked as previously defined.

Commentary:

Approval of the Manufacturing Model by the Owner's Designated Representative for Design can replace the approval of actual shop and erection drawings. For this method to be effective, a system must be in place to record review, approval, correction and final release of the Manufacturing Model for fabrication of structural steel. The versions of the model must be tracked, and review comments and approvals permanently attached to the versions of the model to the same extent as such data is maintained with conventional hard copy approvals. The CIS/2 standard provides this level of tracking.



AMERICAN INSTITUTE OF STEEL CONSTRUCTION, INC.
One East Wacker Drive, Suite 3100, Chicago, Illinois 60601-2000

AISC 303-05 (2M505)