



Illustrated Guide for Building a Spira International Ply on Frame Boat

by Jeff Spira

Plans for these boats may be found at:
<http://www.spirainternational.com/>

Published by
Spira International, Inc.
Copyright © 2010
All Rights Reserved

Building a Spira International Ply on Frame Boat

by Jeff Spira

Hi, I'm Jeff Spira. I've been designing, building and sailing boats for nearly 40 years. I'd like to thank you for deciding to buy a Spira International boat plan. These are, I believe, some of the easiest modern home built boat plans available anywhere.

I have a Mechanical Engineering degree from California Polytechnic State

University in San Luis Obispo located in coastal central California. While I was at Cal Poly I apprenticed under a Naval Architect and Boat Carpenter helping to design and build boats. I also commercial fished out of Morro Bay fishing for Albacore tuna and Rock Cod (sometimes referred to as Pacific



Red Snapper) I also lived on a commercial boat for quite a while while attending school. At this time I did everything I could to get out on the water, whether it was surfing, sailing, fishing, diving, and swimming. If it had anything to do with water, I was ready.



After college I stayed in the marine industry and designed and build heavy load lifting and moving systems for shipyards and offshore drilling rigs. In 1977, I was the project engineer for the world's heaviest lifting device, the 25,000 ton shiplift platform built in Batangas Bay in the Philippines. This enormous platform could lift 700 foot long ships 60 feet out of the water then transfer them into the shipyard on wheeled bogies for repairs.

I did a number of other shipyards and heavy load lifting and moving systems as well, including the Denver Mile High Stadium east stands expansion (the world's biggest moving land structure at 16 stories tall and 5000

tons) and the moving drill floors for a number of offshore drilling rigs.

You may have experience with some of my other engineering projects, including the nosewheel steering systems used on all commercial aircraft from the Boeing 737 up to and including the 777. I also designed critical components used in General Motors cars and trucks. So if you have a Chevy or GM truck, everything from an S-10 to the Suburban, full sized pickups and even up to 2-1/2 ton commercial trucks, you are relying on my engineering skills to get you safely home. That system was adapted to the luxury Buick Pontiac and Cadillac sedans as well.



It was into the 1990s though when I began selling my boat designs. I took my very different design philosophy and applied it to easy-to-build, extra strong boats that any beginner can build into a fun and safe boat without specialized materials tools or techniques. You may not think what I do is particularly revolutionary, but it is quite different from other designers and results in a light, strong, very quick to build design.

The boats I design are not wooden boats in the traditional sense. In traditional wooden boats, the wood framing is attached together and the planking is fastened to the frames with fasteners that are used to transfer the loads of the water to the various parts of the hull. Not so in Spira International boats. These boats are designed as unified structures, much like the unibody construction of cars or modern bonded monocoque construction of airplanes combines the framing and the skin into a single structure from a structural point of view.

In addition, traditional wooden boats absorbed water into the wood to become soaked, swelling up to seal the joints. In a Spira International boat, the wood separated from the water by a barrier of epoxy that is a hard plastic when cured keeping water out. These are intended to be hybrid composite boats, not wooden boats, so the standard rules of what constitutes a good boatbuilding material is not applicable to SpiraInternational boats.

Balsa and foam are sometimes used as the cores for composite boats, and these materials are very porous and have low strength, yet they can create very tough hulls, so don't get too hung up on the strength of the materials you use thinking they won't make for a sound hull. I've analyzed the strength of these structures to be amply strong no matter what species of wood you elect to use.

Tools for Spira International Framed Boats

To build the one of these boats, you should also be familiar with using wood working hand tools and hand-type power tool such as saber saws, electric drills, and electric sanders. You could build this boat using only hand tools but power tools sure makes the construction go much faster. I personally find the time savings using power tools allows me to do a better job. For instance, if I set out to sand a boat, I get bored in a few hours and if I'm hand sanding, I won't have made nearly as much progress than if I'm using a power sander. In any case, if you have spent some time using wood working tools, you'll have no trouble building a boat. If this is your first endeavor into any kind of wood working, I'd suggest building a tune up project of some type before building the boat. One great idea is to build a pair of saw horses. You'll need them to build the boat and it will give you a give you a chance to get used to the tools.

To build a Spira International ply on frame boat design, following is a list of suggested tools you'll need. This can be considered a minimum list.



Power Tools

- Saber Saw
- Electric Drill
- Power Sander (quarter sheet random orbital type)
- Electric Screwdriver (not required but sure nice)

Hand Tools

- Block Plane
- Screwdrivers (both straight & phillips)
- 20 (or more) 2" or 3" "C" clamps
- Hammer
- 3/4" or 1" Woodworking Chisel
- Back Saw
- Framing Square
- Yard Stick,
- 25' Tape Measure

Of course there are some other tools that could come in handy, such as a table saw, a power plane, and one of my favorites, an old fashioned drawknife. Don't concern yourself with having a full tool chest before beginning. You can add tools as you need them.



The concept of too many clamps is not one boat builders are able to grasp. A variety of different types of clamps make boat building easier.

Lumber for Spira International Framed Boats

Not a day goes by that I don't get an email from someone who wants to know if such and such species is OK to use, or to say that their local Home Depot doesn't stock the species of wood I call out on my drawings. I'm in the process of redoing the drawings removing most of the species from them, but until I do, I'm sure I'll get a lot more questions.

The first consideration you should make is usage. If you are planning on a 5 year 'round the horn' sea voyage, obviously you should select your materials with more consideration and care than if you are building a small row boat to keep at your mountain cabin to use a weekend a month on the local lake during the summer months. Nonetheless, you are going to put lots of effort into the construction of your boat and should select the best materials you can, to fit your usage and budget.

There are essentially two different kinds of trees harvested to make lumber. These are Deciduous and Conifer. Deciduous trees are broadleaf treed like Walnut, Oak, Maple, Birch, Mahogany, and similar. These trees lose their leaves in the autumn and regrow them in the spring. Sometimes called broad-leaf trees, the lumber cut from these trees is usually referred to as hardwood.

The other type of trees, the conifers, are evergreens. Pine, spruce, fir, cedar, etc. are conifers. These are sometimes called softwoods. Softwoods are what is used as construction lumber throughout the world because it grows quickly, is easy to mill, lightweight, and is strong enough to create sturdy structures.

Traditionally, boats have been built of hardwood framing, and often had softwood planking but that was when each framing piece was required to carry it's full load rather than being part of an integrated structure.

Any softwood, if it is structurally sound is bonds well, is suitable to build the framing for a Spira International boat. In different parts of the US and in different parts of the world, different species of woods are used as construction materials. For instance, if you walked into a Home Depot in Florida and bought a 2x4 off the rack, it would probably be Yellow Pine, if in Oregon, it would probably be Douglas Fir. Either are equally acceptable from a structural viewpoint to build a Spira International boat.

You can certainly also use hardwoods if you prefer, and some of these are excellent choices, like Mahogany - easy to work, rot resistant, not too expensive, but others might be a bad choice - like Teak - splits easily, doesn't bond well because of the high oil content, or Maple - very difficult to cut and form. It is always advisable to get some sample material before you start and try cutting, planing, and forming it so that you know what you're getting into before you invest heavily in materials and get started on a project that has as many labor hours as a boat.



Conifers include such species as: Douglas Fir, Grand Fir, Incense Cedar, Lodgepole Pine, Mountain Hemlock, Pacific Silver Fir, Ponderosa Pine, Sitka Spruce, Western Hemlock, Western Red Cedar, White Pine, Yellow Pine, and others.



Deciduous trees include Maple, Cypress, Hickory, Oak, Walnut, Willow, Cherry, Dogwood, Elm, Ash, Birch, Beech, Buckeye, Pecan, Ironwood, Poplar, Paw Paw, Olive, Sassafras Tree, Cottonwood, Sycamore, and others.

I've been asked if pressure treated lumber is a good idea for building boats. Well, it certainly isn't necessary, and there's really no need to go through that expense, however if you live in a very high humidity environment, where it rains frequently, you may wish to use pressure treated lumber even though though the wood is sealed with epoxy. The enemy of wood in boats is fresh water, not salt because "dry rot" is really a fungus that only grows in the presence of fresh water. Saltwater kills the plant. This should also be a strong hint to keep standing rainwater from collecting in your boat. A cover and open drain plug holes, when your boat is stored outside are always a good idea.

The biggest concern with using construction grade lumber for building a Spira International type boat is deciding what defects in the lumber are acceptable and which are not. Here are a few of the common defects in construction lumber:

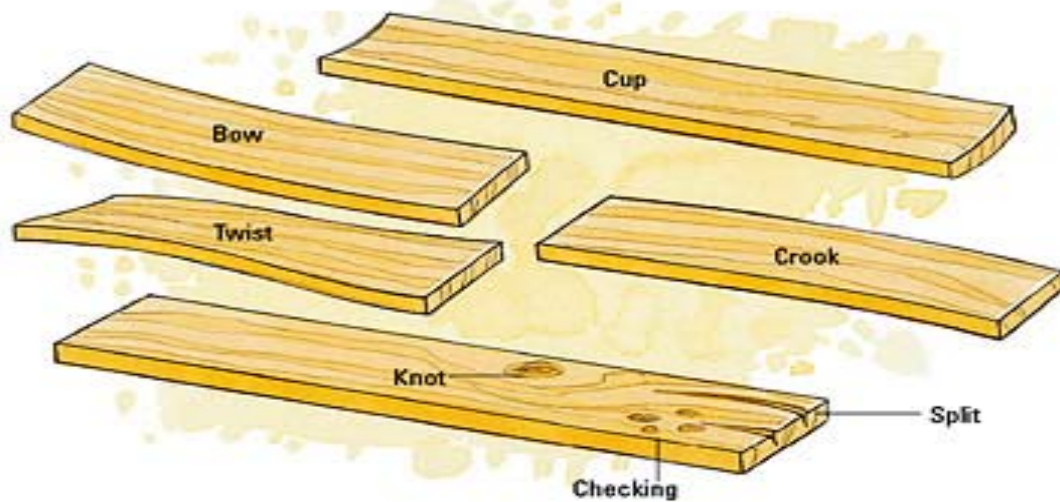

The cups, twists, and warps present no major problems if not too severe, but checking, knots and splits are of some concern. Examine your structural pieces carefully for splits. Any splits should be avoided in all framing. If you discover one after you've already assembled and glued up your framing - don't worry about it, but it is best to cut off any splits you find in lumber before you assemble frame elements.

Knots present a special problem. I often specify clear lumber, which is knot free, but small tight knots are not a problem so long as they aren't at the corner edges of the lumber. Here are some examples of tight and loose knots. Do not use lumber with loose knots:

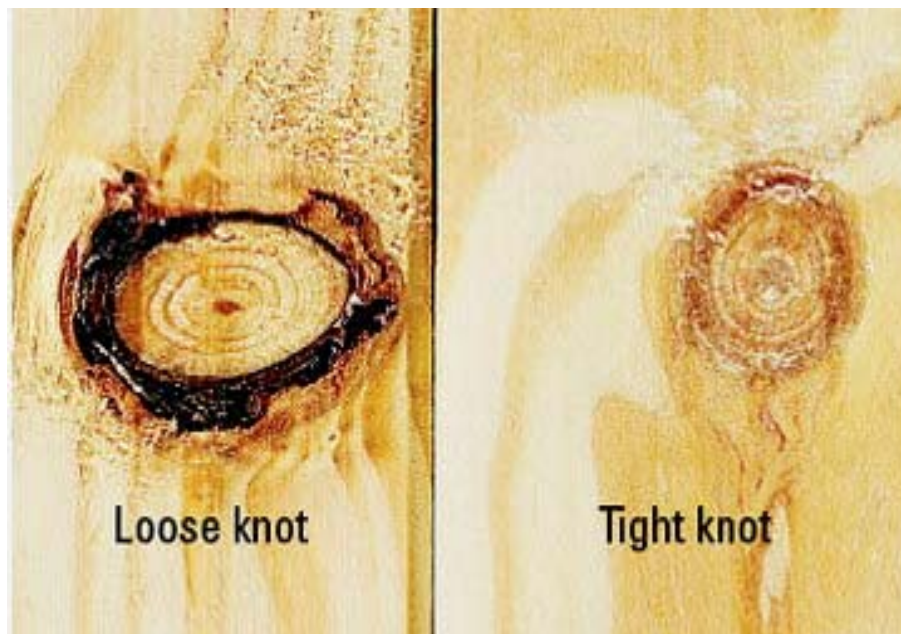

Plywood for Spira International Framed Boats

The question always arises on whether to use marine or construction plywood for building boats. Let's first discuss the different types of ply. There used to be a type of plywood called interior ply that was manufactured using natural glues that would let loose when wet. It is not made anymore. Nearly all ply made now, that I've ever come across uses synthetic, waterproof glues.

Plies made of softwoods, usually fir but sometimes pine, have knotholes. If these are left open on the surface laminations, it is called "C" grade. If the knotholes are filled with football shaped plugs, it is considered "B" grade, and if it has no knotholes, it is considered "A" grade. So ABX plywood would have no knotholes on one side, filled knotholes on the other and has been laminated with waterproof glue (X = exterior.) The problem lies in the interior laminations. In most plywood the knotholes are left unfilled leaving a void on the inside. In marine plywood these interior knotholes are also filled leaving the ply void free.

For my boats, I only recommend marine plywood in the event the builder elects not to fiberglass and epoxy coat the boat on the outside. If the builder decides to glass cover the boat ABX plywood is sufficient.

As an alternate to marine or standard plywood, hardwood plywood may be used. Mahogany and Birch are the most common. They have no knotholes, so don't have any voids. The only downside to using hardwood plys is that they don't bend easily so sometimes you need to laminate two thinner layers of plywood in an area where there is a lot of bends.

Fasteners for Spira International Framed Boats

Screws? Nails? Bronze? Stainless? The array of possible fasteners for home built boats can be confusing, so I thought I'd offer a few guidelines on what may be the best for you. First, you need to know that modern boat designs don't rely nearly as much on fasteners as do their older ancestors. Nearly all home built boats made these days rely on adhesives for joint strength. Epoxy is the most popular with the new polyurethane "Gorilla Glue" type a close second. These adhesives will not fail if properly applied - the wood will break before the joint will give way. They'll even fill gaps that more traditional "glues" would never stand for. This means that when you use epoxy, all the fasteners really do is hold the joint in-place until the epoxy cures. After the epoxy sets up you could theoretically remove the fastener and not affect the joint strength.

Building an old mahogany boat with screws was quite a chore in the olden days. The screw holes had to be pre-drilled, then the screw run in with an old fashioned screwdriver, or perhaps a manual Yankee driver. It was a whole lot of work! New trends in fasteners have come about after the invention of lightweight cordless power drill and screwdriver tools, so it makes it a lot easier to install fasteners. My recommendation is to use what are called "deck screws." These are thin screws that can be screwed into place using a cordless drill without drilling a starter hole. This has revolutionized home wooden boat building world. Like drywall screws have replaced nailing, so have deck screws replaces boat nails. They're easy.

Next materials: It used to be that stainless steel was very expensive, but with most of the fasteners coming from offshore, stainless just isn't that expensive any more and for most trailerable boats, stainless makes an ideal fastener. It doesn't corrode normally with a boat that is kept out of the water even when used in seawater. I can hear the comments from readers now, "but what about everything I read that it corrodes when in seawater and embedded under a sealed surface..." Yes, OK, it can corrode under certain circumstances, but in my opinion, these are few and far between, and see paragraph 1 above - If it does corrode so what?

For a boat that truly is kept in a slip in the ocean, silicon bronze is probably a good idea. It's the finest of all boat building fasteners. They don't come in deck screw shapes, so you'll have to pre-drill starter holes, but you'll be able to drive them in with a cordless drill if you purchase Phillips head screws. You'll probably find silicon bronze ring type boat nails the easiest way to fasten the plywood planking to the framing on a ply on frame boat using bronze fasteners. The thought of drilling all of those starter holes in a ply covered boat would be a daunting task.



A good friend of mine and fellow boatbuilder suggested I look into Raptor Nails for use in boats. These things are incredible. They're composite so can't rust, weather or weaken due to environmental conditions - plus they can be cut with a saw, plan, sandpaper or rasp without damaging the tool's edge. You can pick up a pneumatic gun and shoot them in-place to fasten bonded joints. There's some buzz in the boat building community and those who tried them love them. In your next boat you might think about investing in these new fasteners. They sound like a boat builder's dream. They'd make the ideal ply fastening system.

Glues for Spira International Framed Boats

There are a number of products suitable for building Spira International framed boats but by far the best choice is Epoxy. Epoxy is a 2 part thermosetting (which means it polymerizes into a hard plastic that cannot be reversed - not melted - when cured.) adhesive ideal for boat building because it is extremely strong, flexible and waterproof. The very same resin may be used to laminate fiberglass cloth to the outside of the boat to seal and strengthen the planking.

I often get e-mails from people asking about what kind of epoxy is best to use for building my boats. I've used an online supplier, John Greer, in the past and find his products excellent quality and very well priced. He ships quickly, answers questions promptly and also stocks thickening agents like cab-o-sil and microspheres, and also carries fiberglass cloth and tape, also at excellent prices. Check out his web site: <http://www.jgreer.com/>.

You may also use polyurethane adhesives, such as Elmer's Ultimate, Stick-Ass Glue, DAP Polyurethane and others. These will also make the 'stronger than the surrounding wood' joints, sufficiently water resistant for boat building use.

Framed Boat Building Procedure

Building a wooden framed boat is best accomplished on a strongback. Generally this is made of a strong wooden beam just long enough to fit inside the boat. This brings the boat up to a comfortable working height and keeps everything aligned while the boat is under construction. On some of the boat designs the strongback is detailed and on others it's left up to you. This is usually dependent on how complex the strongback needs to be. If a smaller boat, it's usually quite simple to construct.



The next step is to build the frames. To begin with you need a plywood board on which to lay out your ribs. Make sure the ply has square and parallel edges. You'll also need a framing square and measuring device of some sort. I have a 4' aluminum scale (like a yardstick) but you can get by with a tape measure. Some guys just draw right on the plywood, others prefer to use a sheet of butcher paper on the board.

First you draw a centerline to work from, then measure off the horizontal distances just as they are specified on the drawings and using the framing square, draw vertical lines through these measured points.

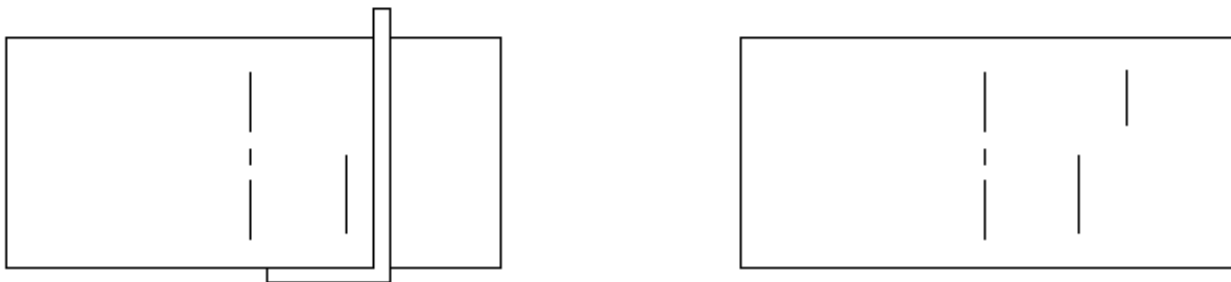

Next draw a perpendicular baseline from which you measure the vertical distances as shown on the drawings. Then use your framing square to scribe horizontal lines through those points that intersect the vertical lines determined above.

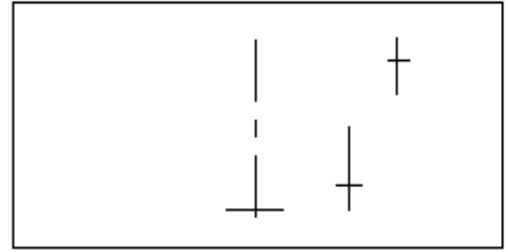
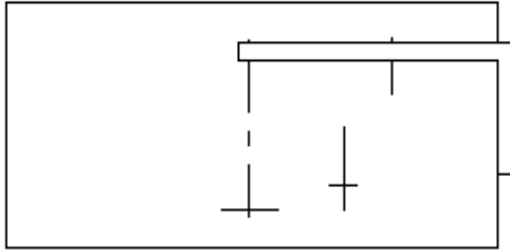

Finish off the frame drawing with lines connecting the locations Repeat for the other side as well.

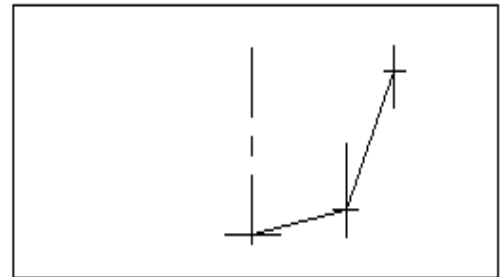
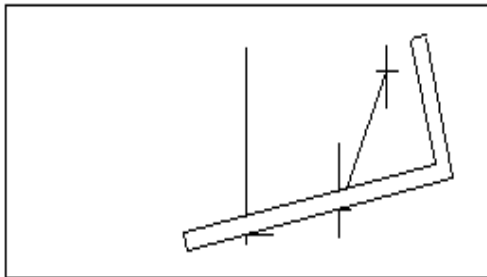

The wood frame members are then cut and laid out on the pattern, then drilled, glued with epoxy, and bolted together to form the shapes as shown on the drawings.



While most of the frames are built using lap joints, the transoms are not They are built exclusively using butt joints - all flat on one level. The adhesive will hold the joints together well enough until the plywood covering can be added. This is what really ties everything together. Here are several transoms, one for a drift boat and the other a power boat so you can see how this is done:



Next, you need to set the ribs on the strongback.. On some boats like the Carolina dories, or some of the Grand Banks dories, the bottoms are straight, so there's no need to block up the frames. Just tack them to the strongback in their correct longitudinal locations. Still other boats, like many of the v-bottom hulls, have the strongback designed so that you do not need to worry about heights. But on many boats, you will need to raise the ribs up from the strongback to create "rocker" or a curve to the bottom. Temporary simple blocks may be used, or more complex, notched blocks can be created to create this curve.



Once the strongback is complete, the framing is temporarily attached so that the remainder of the framing may be attached and create a single unified structure. Generally this is begun by first attaching the transom to the strongback. In most cases, a height is given. (If not, the height will be obvious, such as being flush with the jig.) It is important to note that this height is always to the inside of the framing, i.e. the forward edge of the transom.

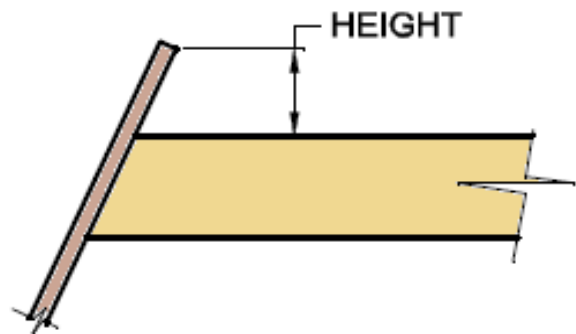

Generally, the dimension from the transom to the first frame is specified, but if it is not, it is the standard frame spacing ahead of the inner edge of the top edge (when rightside up) of the transom to the joint plane of the first frame:

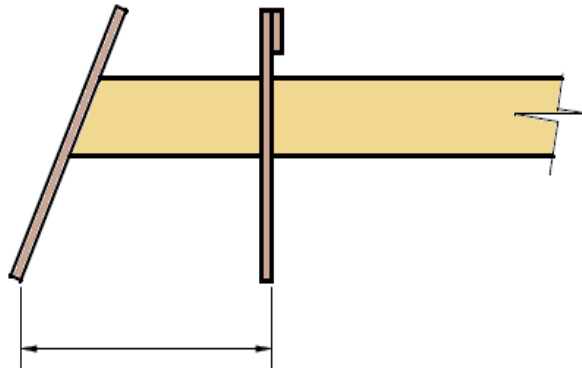

I'm sure that most readers will think that from here forward all you need to do is measure from frame to frame the standard frame spacing dimensions like this:

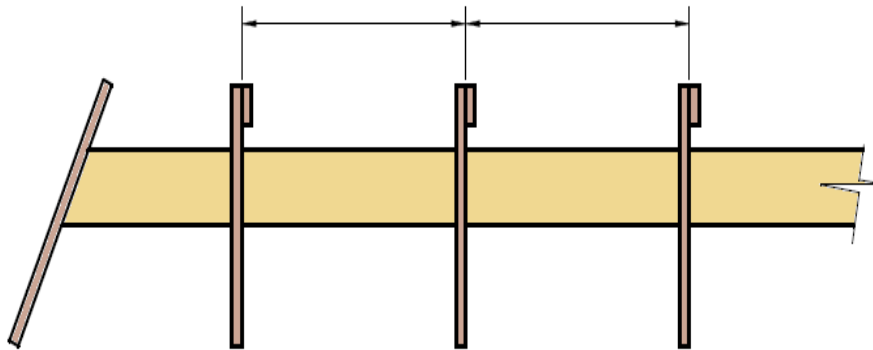

Unfortunately that would be a big mistake. Suppose you are too big by 1/4" (less than the thickness of your pinkie) in this dimension setting frame two, then again, in setting frame 3 and so on. By frame 10 you would be off 2-3/4 inches, enough to make your boat a disaster. The correct way to do it, is to use frame 1 as a reference and set all frames based on frame #1, like this:

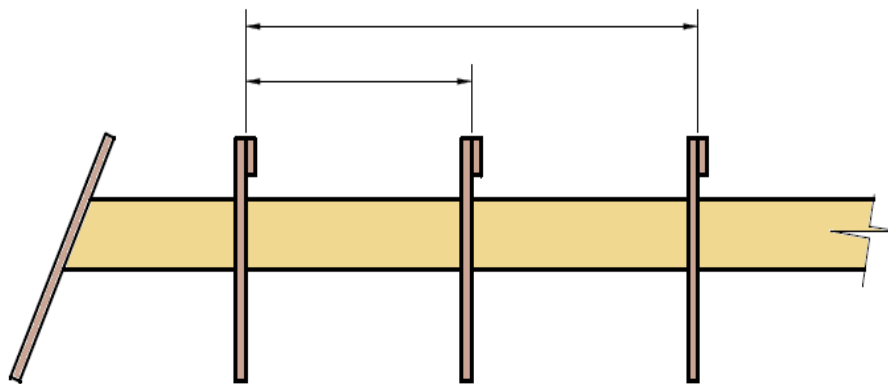

So if the standard frame spacing is 1' 6", then frame two is 1' 6" away, frame three is 3' away, frame four is 4' 6" away, frame five is 6' away and so on. That way if you make a mistake in placing the frames by 1/4 inch, the errors don't accumulate and add up, so a 1/4 inch mistake in placing frame 10 is still only a 1/4" mistake - not noticeable at all, in the overall lines of the boat.

At some point in the hull, you come to a place where the hull quits getting wider and starts getting narrower. This is when the frames reverse. On newer designs, I identify this transition with notes, but on older designs, it is only indicated in the pictures. The theoretical ideal lines of the boat are always designed to the reference plane of the frames, and that means the lap joint. That means the spacing is always to where the lap joint is, even though the bottom frames and side frames reverse direction:

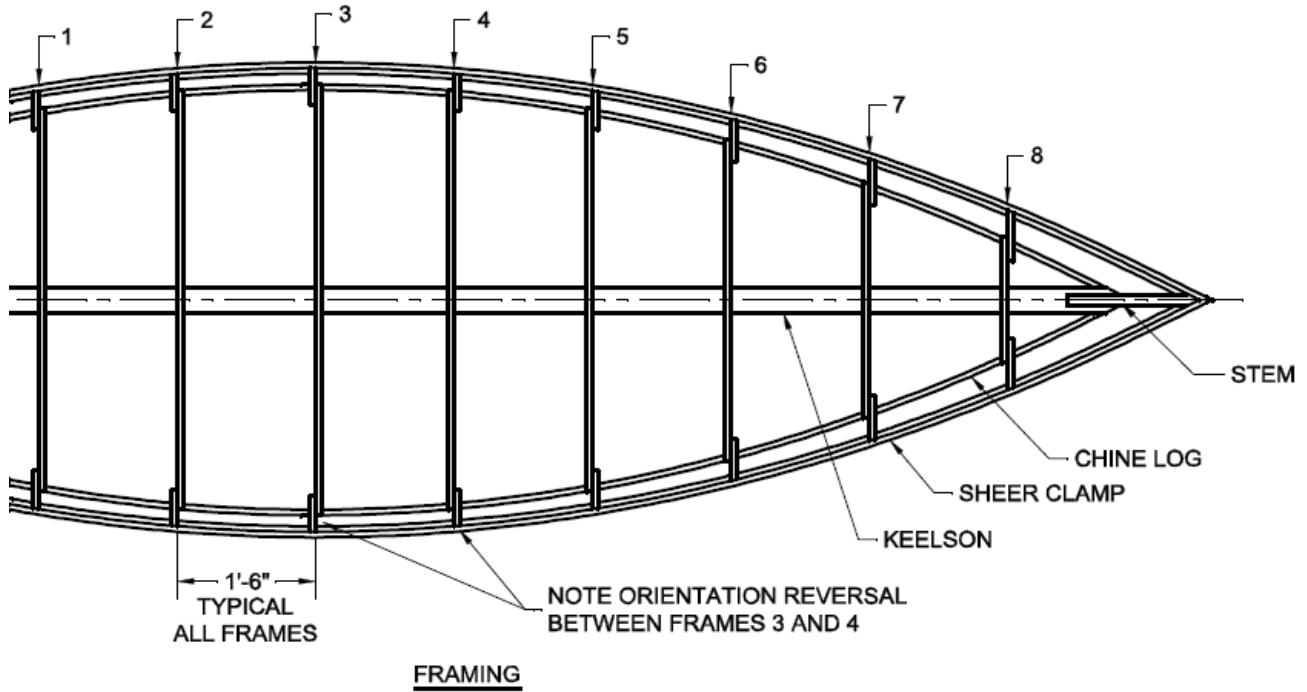

Between frames 3 and 4 in this Inagua drawing, the frames flip their orientation so that the theoretical ideal lines always intersect the frame at the plane where the bottom ribs and side ribs meet in the lap joint. So just remember that the correct rib spacing is always lap joint to lap joint:

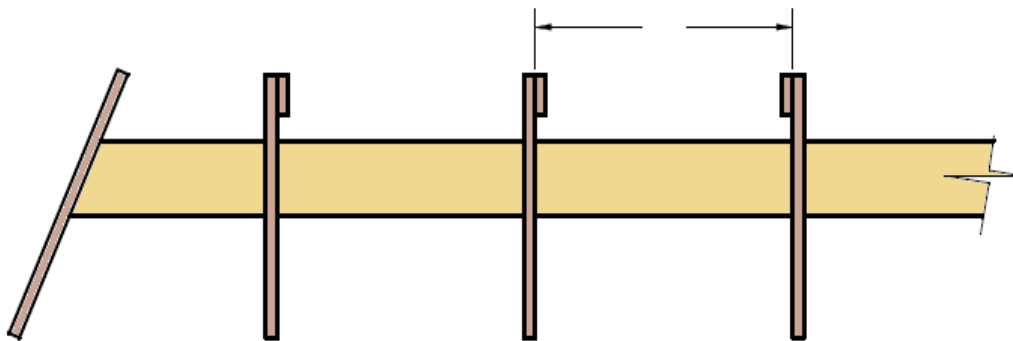

Of course, this frame should also be spaced the correct distance from Frame 1, not the frame just before it, but the dimension lines show you which plane, fore or aft, you should measure to - always to where the lap joint is.

The stem is attached to the strongback jig at the bow of the boat. It may have a actual dimension to it's highest point like this:

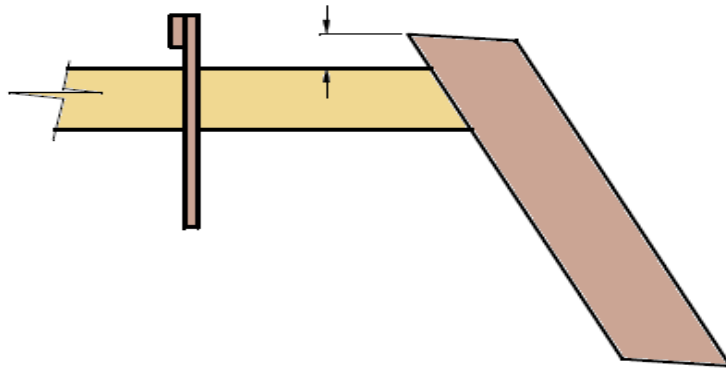

... or it may be an obvious point, such as flush with the top of the strongback. In either event, it needs to be fastened to the strongback and held in-place. Stem knees are added later, after the longitudinals have been installed.

Next the aft end of the keelson is beveled to fit flush, then glued. Screws are run into the aft (end grain) end of the keelson through the transom, securing it into place. Work forward from here attaching the keelson to each frame as you go, and when you get to the stem, glue and run screws downward through the keelson into the base of the stem:

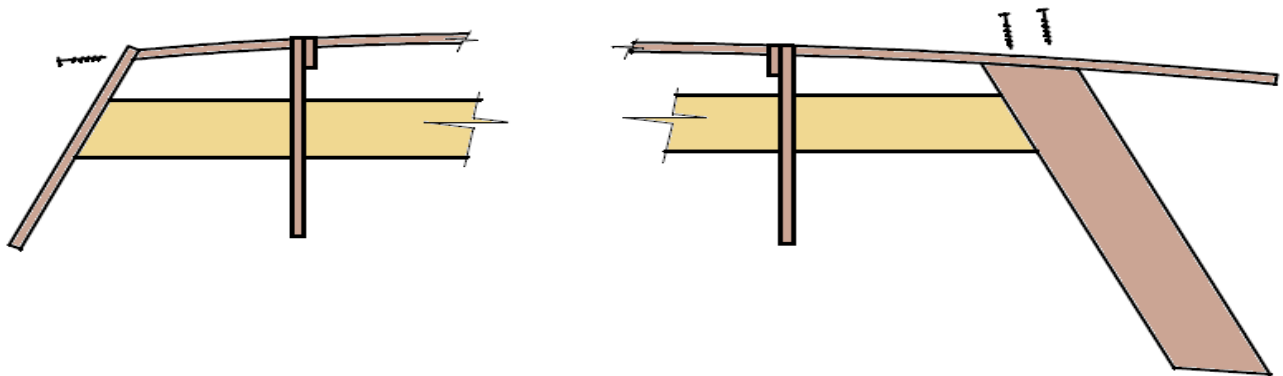

The keelson is then trimmed to its final length and prepared for further trimming when the chine log and sheer clamp are installed. See the sheer clamp and chine log fitting guide for more detail on that process.



The chine log comes next. You must cut out notches in the frames as shown on the drawings. The easiest way to do this is by cutting a small piece of the material used for the chine log and sheer clamp to use as a marking tool. Holding it up to the top of the frame and angling it to the approximate angle it will be sitting once attached. Simply use a pencil to mark the top (for the sheer clamp) or bottom of the frame (for the chine log) then mark the side of the frame for the correct distance of the cut to account for the width of the material. No need to get too fussy at this stage, you'll get a chance to fit it better using a rasp or file for a good tight fit. Here's how that marking and cutting will look:

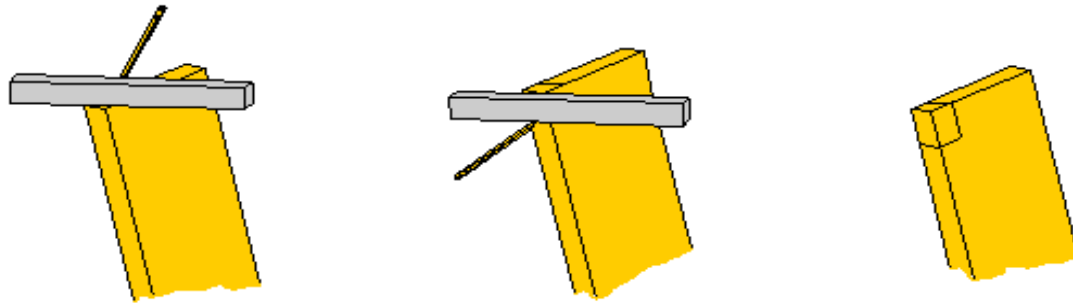

Then use a back saw to cut out the notches at the correct angles.

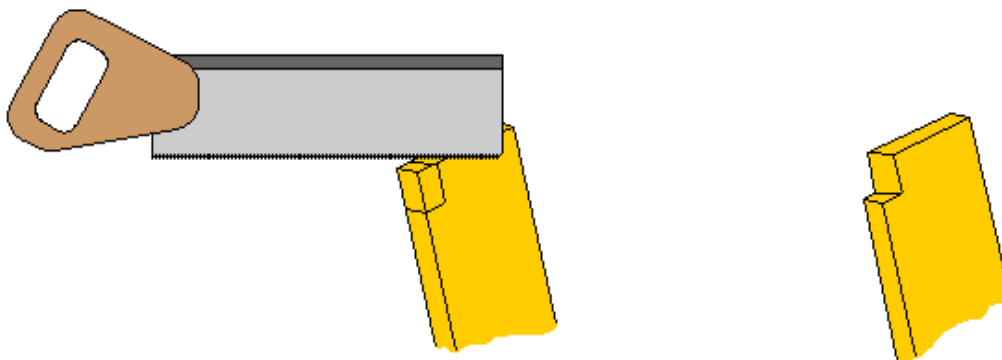

There is no need to obtain the sheer clamp and chine log materials in full lengths. For some boats this would be impossible to find, for others, just difficult and expensive. You can choose good quality construction lumber and scarf pieces of it together to achieve the desired lengths. A scarf joint will look something like this:

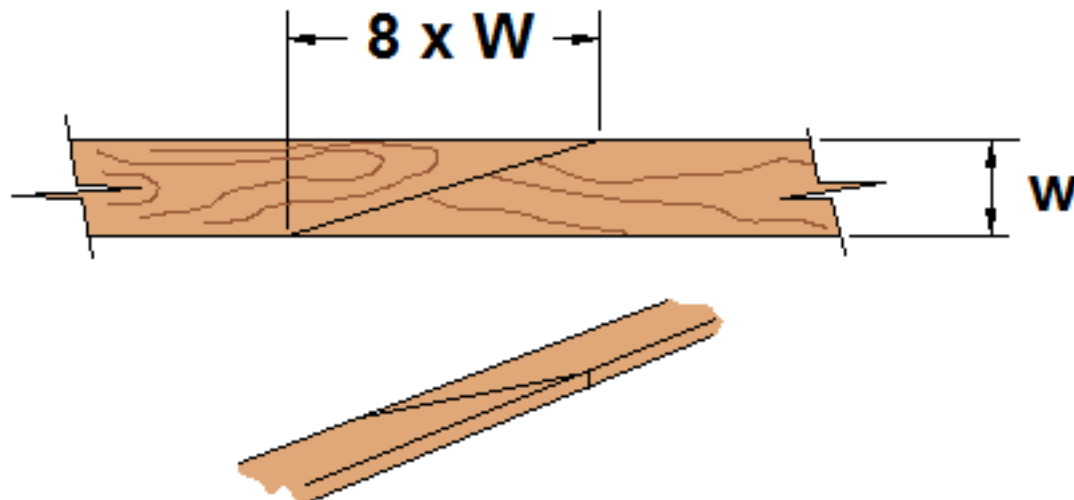

As you approach the bow and stern, you'll need to notch the transom and stem to receive the sheer clamp and chine log.

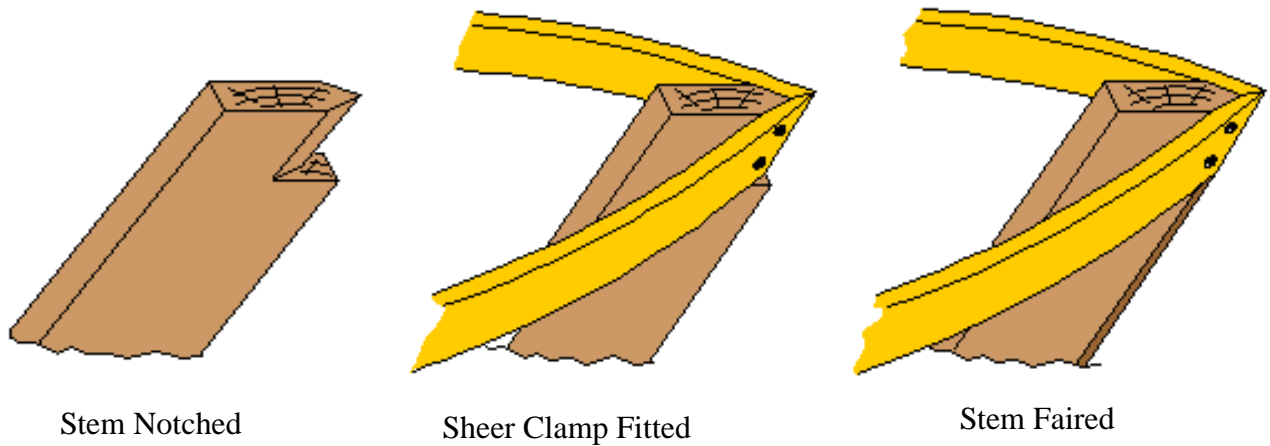

Once the framing is complete, the next step is to "fair" the boat. This involves planing the frames and chine log so that plywood will smoothly fit on the outside of the boat. Take your time doing this so the fits are tight and smooth. Some people (and I include myself) like a drawknife for this work, but be careful, it takes some practice to keep from removing too much material.



There is no way to pre-determine the exact sizes and shapes of the plywood for framed hulls beforehand. If you build each rib within plus or minus 1/8" and locate them precisely within plus and minus 1/8" the plywood planking can vary by as much as 2"! It's probably more likely that most of these dimensions will vary by a good deal more than that. I'd say if a builder gets within 1/2" he's probably doing a pretty good job on his boat. This means that the plywood planking shape can vary between one hull and the other by as much as 6". It just doesn't make any sense to try to cut this out beforehand.

The correct way to cut out the plywood is to first frame the hull. Put all elements in-place, glued and fastened so that the precise hull size and shape is fully established:



The boat's framing is then used as the only reliable pattern to cut out the plywood covering. This is done by clamping the plywood in place where you wish to locate it on the framing as shown here:



You then trace around the framing onto the plywood with a pencil being sure to cut it a little oversized to make sure you get full coverage of the area. Then remove the plywood and cut it out along the lines you drew.

Once you cut out the plywood, you can then glue and screw it into place.

The extra material left projecting over the edges of the framing is easily removed with a rasp, sander or angle grinder to make the edges precisely align with the framing below:



Wherever there are joints abutting, a butt block must be installed. These are 6" wide, made from the same thickness of stock as the plywood sides themselves and fitted on the inside from frame element to frame element (usually from chine log to sheer clamp.) These are then glued and placed straddling the joint on the inside. Screws are then run through the hull from the outside into the butt block to secure it in-place until the adhesive cures fully:



If the plywood cannot make the bend or twist it needs, it is perfectly acceptable to cover it in a series of narrow plywood strips:



Following the ply covering, you want to carefully fill all of the cracks voids, screw heads, holes and other imperfections on the surface of the hull. The easiest thing to do this with is epoxy with fine sawdust (wood flour) like you get from a sander, mixed in. It turns the fluid epoxy to a putty like consistency that is easy to apply, smooth, and sand later after it is cured.



Next - sand the hull smooth. (It's not nearly as much fun as it looks!)



Once the hull is smooth and sanded, it's time to fiberglass. Spira International framed boats are generally designed to be sheathed in 2 layers of 6 oz fiberglass cloth on the outside only. Larger boats could use three or four layers, and the thickness of the cloth could be stepped up to 10 oz cloth if more rugged usage is anticipated.

Some people elect also to use fiberglass tape on the seams. This is a good idea as it reinforces the joints well.



To glass the hull, begin by cutting out the fiberglass so that it overlaps all edges and its own panels by at least 3”



It is best to cut all panels out first, bottoms and sides, because you'll want to make sure that once you mix up a batch of resin you use it all before it starts to harden - usually 3 or 4 hours. You could apply both layers of glass for most boats in this amount of time. It is perfectly acceptable to add a layer of fiberglass over another layer while it is still wet. In fact it is preferred.

If the plans call for a layer fiberglass between two layers of plywood, have the second layer of plywood cut out and ready to go, too. You'll want to get it on before the epoxy is fully cured.

Next, mix up a batch pf epoxy resin in accordance with the manufacturer’s recommendations and paint or squeegee it on the area you wish to fiberglass:



Then spread out the glass cloth on the wet epoxy, apply a second coat and squeegee it in until the glass cloth turns from white to transparent. This tells you the glass is wetted out properly.



You can lay the second layer of cloth right over the first that you just wet out if it is still tacky. If the epoxy is cured already, apply another coat of epoxy resin over the cured epoxy before laying the next layer of cloth on.

Once it is cured you will be able to see the texture of the cloth on the surface.



This will require considerable sanding to get smooth. A trick to minimize this effect is to use plain old waxed paper, the kind your grandmother wrapped sandwiches in. Just lay it on the wet glass/epoxy surface after wetting and roll down. After the epoxy cures, the waxed paper will peel off and leave a smooth surface that needs only minimal sanding.



Once you peel off the waxed paper, three things need to be done: 1) sand, 2) sand, and 3) sand some more.



The sander can also be used to trim the excess fiberglass that extends above (below when upside down) the sheer line. This is probably the easiest way to do this.



About now, you'll start to wish you had taken up basket weaving instead of boat building, but keep at it anyway, and eventually you'll get the finish nice and smooth.



The rub rails come next. These are put outside of the fiberglass so that they can be changed or repaired ore easily. Their purpose to to absorb bumps and dings so that your hull doesn't take that abuse, so expect some wear over time:



Next comes time for paint. Often boat builders are confused on which type of paint to use. Your paint selection will depend on your intended use and application. If it is going to be used occasionally in fresh water, and stored dry in a garage or shed, you don't have to be too picky - any expterior enamel will work just fine. If you intend to store it outdoors, you may wish to use an epoxy paint, as the next step up, and if you intend to keep it in saltwater for extended periods of time, a marine paint will give you the best endurance. Ask your paint supplier if a primer is recommended with teh type of paint you intend to use. I nearly always use one for exterior enamel, rarely for epoxy paint.

You can apply with either a spray gun, if you have the equipment and experience, or with a brush:



If your plan is to let the wood shine through, apply several coats of polyurethane varnish over the outside of the hull are called for. This will seal the surface, make it shiny, and protect it from both ultraviolet rays from the sun and from degradation from the water.



Now it is time to buy a couple cases of beer and to invite all of your friends over for a boat flipping party.



Once you get it right side up, you'll see places where your fastening missed, where drips of epoxy came through and the like. Clean everything up, fill any holes, then mix up a batch of epoxy to saturate the inside of the hull with epoxy. This strengthens and seals the wood for a strong durable finish.



Your hull is now done!

Originally I designed interiors and seating arrangements for my boats, but ended up spending the majority of my time answering questions about how to change from two seats to three, can I put in a center console and on and on, so I really don't do interior arrangements any more. By the time you've completed the hull, I trust you have ample experience to design and install some simple decking, thwart seats, or a casting deck in the bow of your boat. There are infinite possibilities, so have at it and enjoy. Following are a series of photos that will give you some ideas of what can be done. Let your imagination go wild:







Lightweight cabins are always a possibility also:



The operative word here is LIGHT. Please contact me before doing any major construction though.

Appendices

These drawings are offered as optional information. They may or may be applicable to your particular boat.

NOTICE
 THIS DRAWING CONTAINS A PROPRIETARY DESIGN ASSIGNED TO SPIRA INTERNATIONAL, INC. ALL RIGHTS TO DUPLICATE, TRANSFER OR SELL THIS DESIGN ARE EXPRESSLY RESERVED. THE BUYER IS LICENSED TO BUILD ONE ASSEMBLY FROM THESE PLANS.

REVISIONS		DATE	APPROVED
ZONE	DESCRIPTION		
LTR			

- NOTES:**
1. SUITABLE LENGTHS 6' TO 7' - 1/2"
 2. EPOXY ALL JOINTS
 3. WRAP HANDLE WITH CORD OR USE HYPALON GRIPS
 4. SATURATE ALL BARE WOOD SURFACES WITH EPOXY
 OPTIONAL: COVER WITH 1 LAYER OF 6 OZ FIBERGLASS CLOTH & EPOXY.

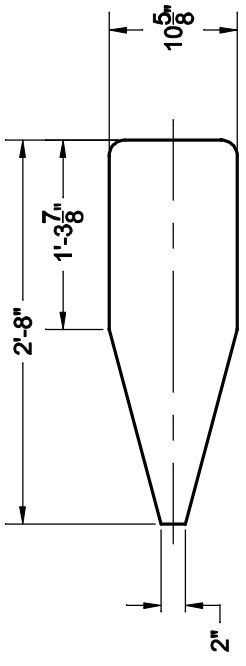

PADDLE BLADE - 1/2 PLY - 2 REQ'D

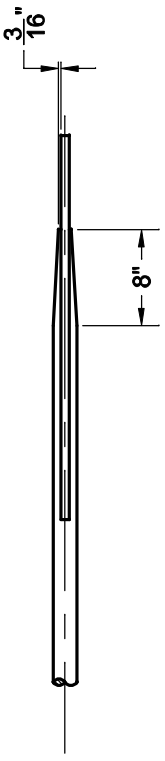

CLOSET POLE
 (1-1/2" FIR)

1" HICKORY
 DOWEL

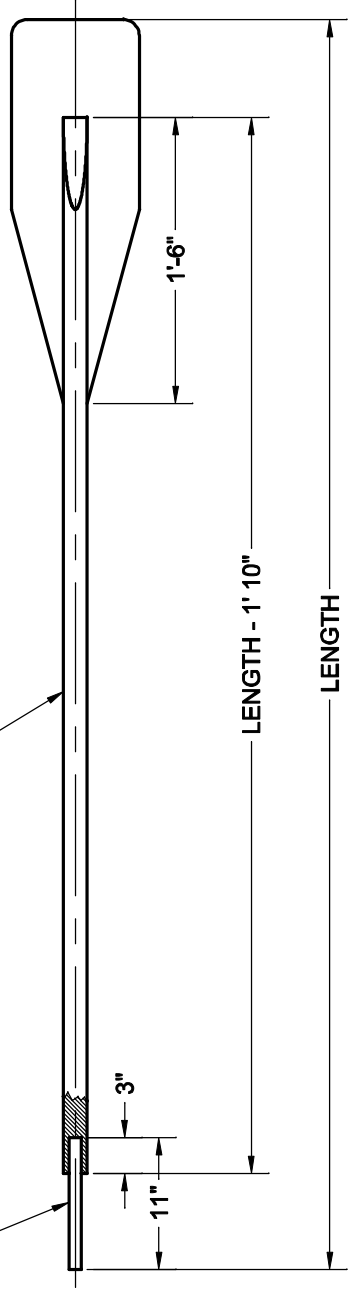

Spira International, Inc.
Huntington Beach, California

HOME BUILT OARS

DRAWN BY: J. SPIRA DATE: 04/10/09 DRAWING NO. OARS01

SCALE 1-1/2" = 1' SHEET OF

NOTICE
 THIS DRAWING CONTAINS A PROPRIETARY DESIGN ASSIGNED TO SPIRA INTERNATIONAL, INC. ALL RIGHTS TO DUPLICATE, TRANSFER OR SELL THIS DESIGN ARE EXPRESSLY RESERVED. THE BUYER IS LICENSED TO BUILD ONE ASSEMBLY FROM THESE PLANS.

REVISIONS				
ZONE	LTR	DESCRIPTION	DATE	APPROVED
	B	UPDATED TO NEW FORMAT	01/07/09	JJS

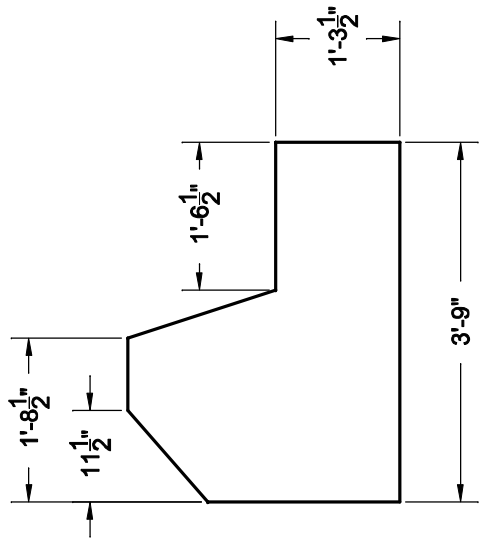

CONSOLE SIDES
 2 REQUIRED

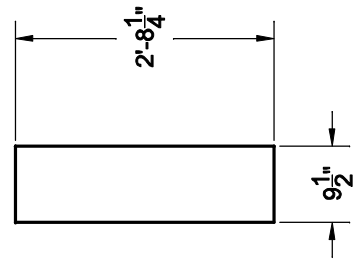

CONSOLE TOP

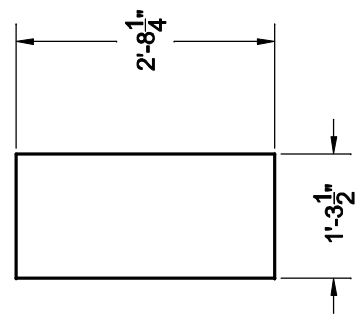

DASH

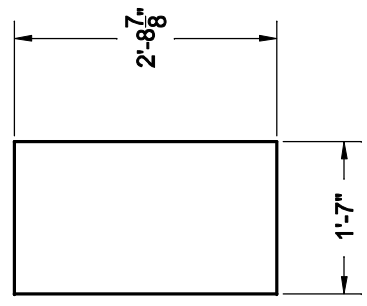

CONSOLE SEAT

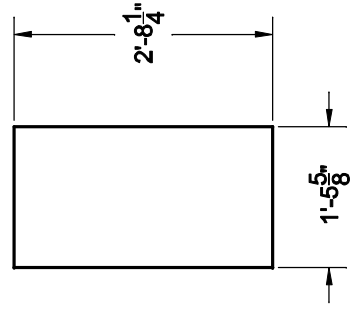

BACK

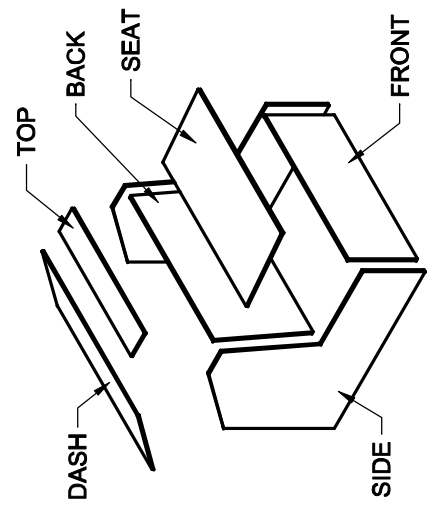

ALL PARTS MADE FROM
 1/2" PLYWOOD

Spira International, Inc.
Huntington Beach, California

CONSOLE DETAILS
 VEE BOTTOM FISHING BOAT

DRAWN BY: J. SPIRA	DATE: 04/09/02	DRAWING NO. SAND06
-----------------------	-------------------	-----------------------

SCALE 1" = 1'
 SHEET OF

REVISIONS		
ZONE	DESCRIPTION	DATE
LTR		

NOTICE
 THIS DRAWING CONTAINS A PROPRIETARY DESIGN ASSIGNED TO SPIRA INTERNATIONAL, INC. ALL RIGHTS TO DUPLICATE, TRANSFER OR SELL THIS DESIGN ARE EXPRESSLY RESERVED. THE BUYER IS LICENSED TO BUILD ONE ASSEMBLY FROM THESE PLANS.

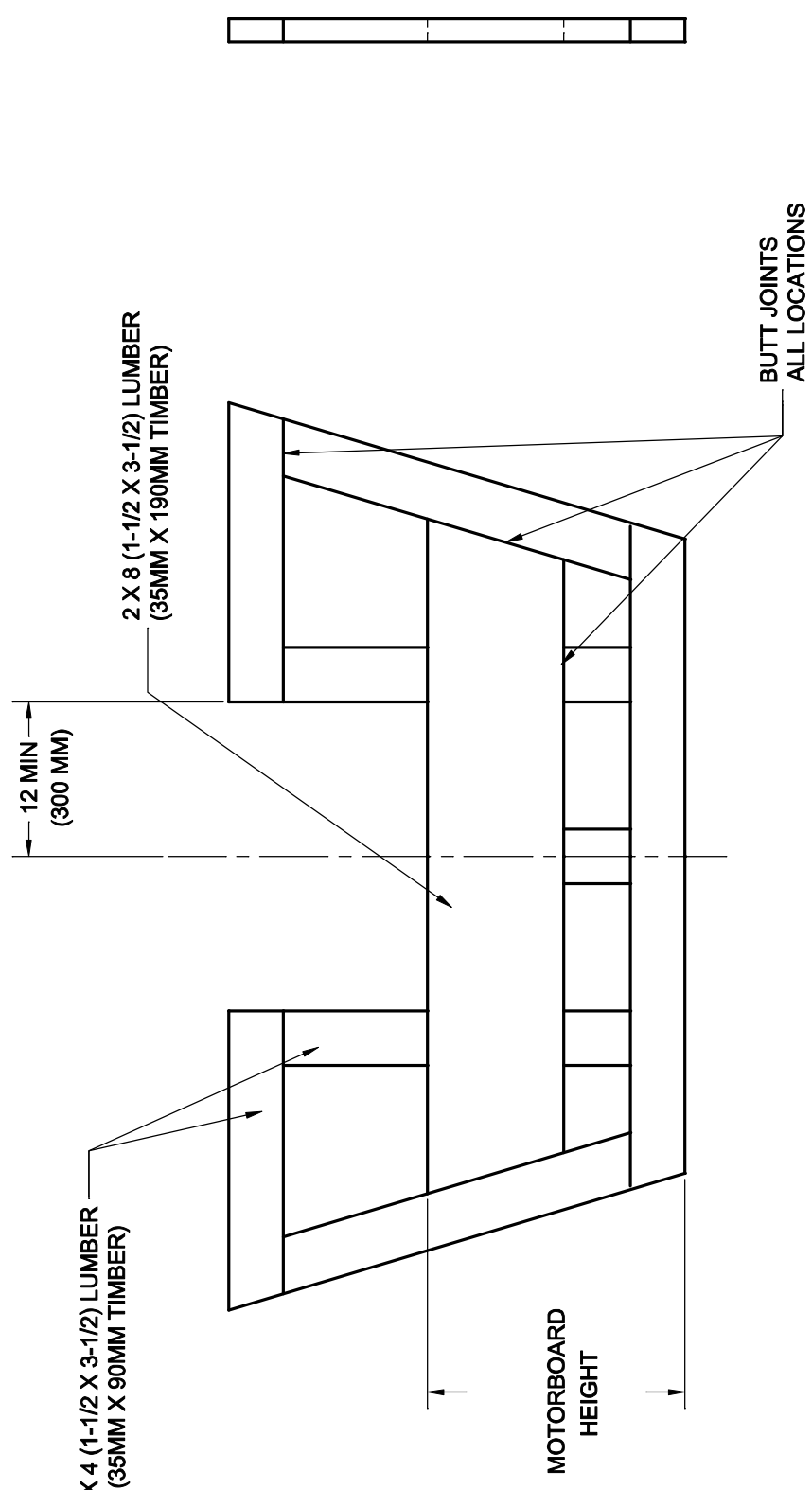

MOTOR SHAFT	MOTORBOARD HEIGHT	
	INCHES	MM
SHORT SHAFT	15	380
STANDARD SHAFT	20	510
LONG SHAFT	25	635

Spira International, Inc.
Huntington Beach, California

TRANSOM CONSTRUCTION
ALL FRAMED HULLS

DRAWN BY: J. SPIRA DATE: 10/01/10 DRAWING NO. TRANS

SCALE 2" = 1' SHEET OF

REVISIONS		
ZONE	DESCRIPTION	DATE

NOTICE
 THIS DRAWING CONTAINS A PROPRIETARY DESIGN ASSIGNED TO SPIRA INTERNATIONAL, INC. ALL RIGHTS TO DUPLICATE, TRANSFER OR SELL THIS DESIGN ARE EXPRESSLY RESERVED. THE BUYER IS LICENSED TO BUILD ONE ASSEMBLY FROM THESE PLANS.

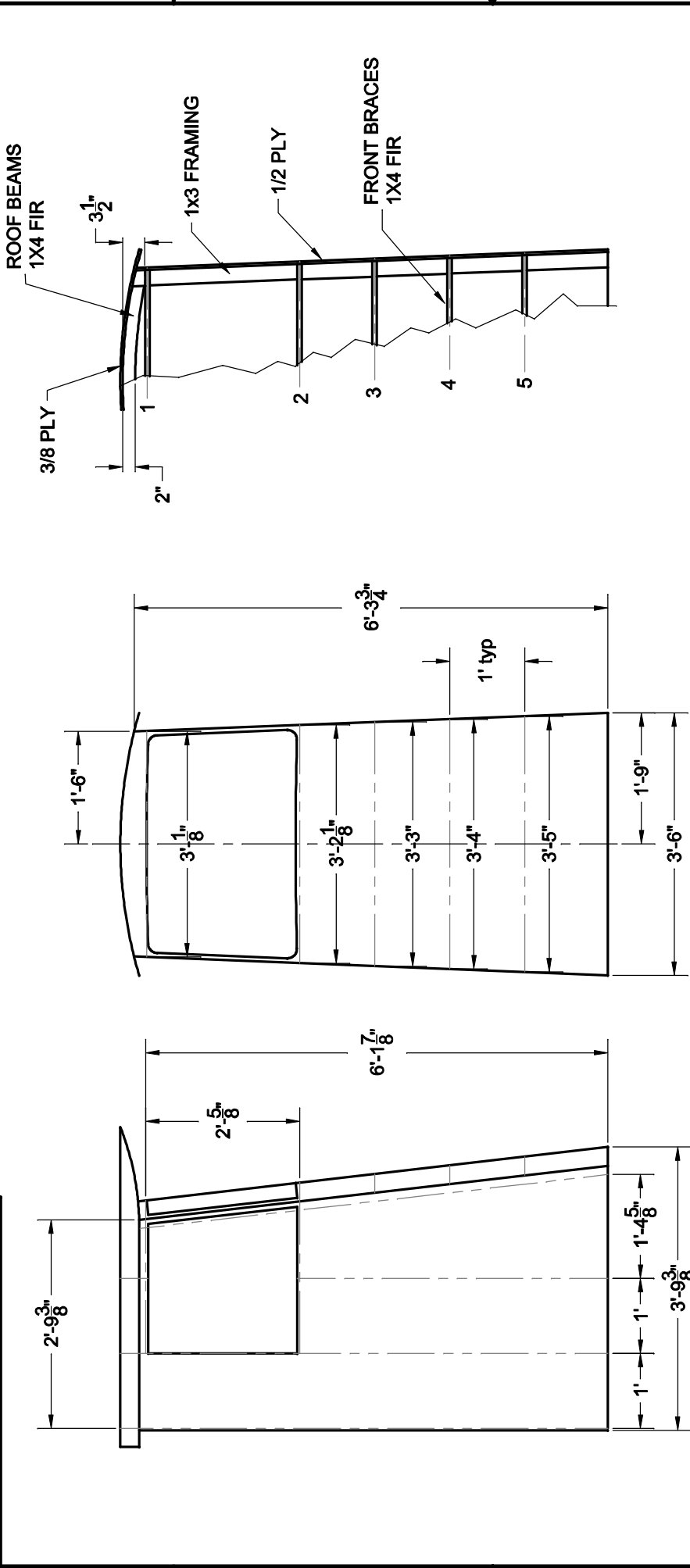

BRACE	LENGTH (L)
1	3' 1/8"
2	3' 2-1/8"
3	3' 3"
4	3' 4"
5	3' 5"

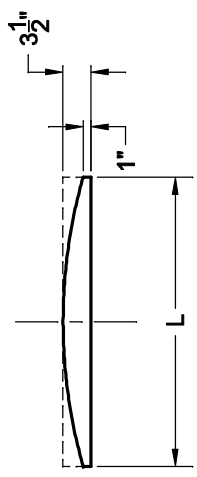

FRONT BRACES

Spira International, Inc.
Huntington Beach, California

PILOTHOUSE

DRAWN BY: J. SPIRA DATE: 09/12/08 DRAWING NO. PHSE01

SCALE: 1" = 1' SHEET OF

NOTICE
 THIS DRAWING CONTAINS A PROPRIETARY DESIGN ASSIGNED TO
 SPIRA INTERNATIONAL, INC. ALL RIGHTS TO DUPLICATE, TRANSFER
 OR SELL THIS DESIGN ARE EXPRESSLY RESERVED. THE
 BUYER IS LICENSED TO BUILD ONE ASSEMBLY FROM THESE PLANS.

REVISIONS		
ZONE	DESCRIPTION	DATE
LTR		

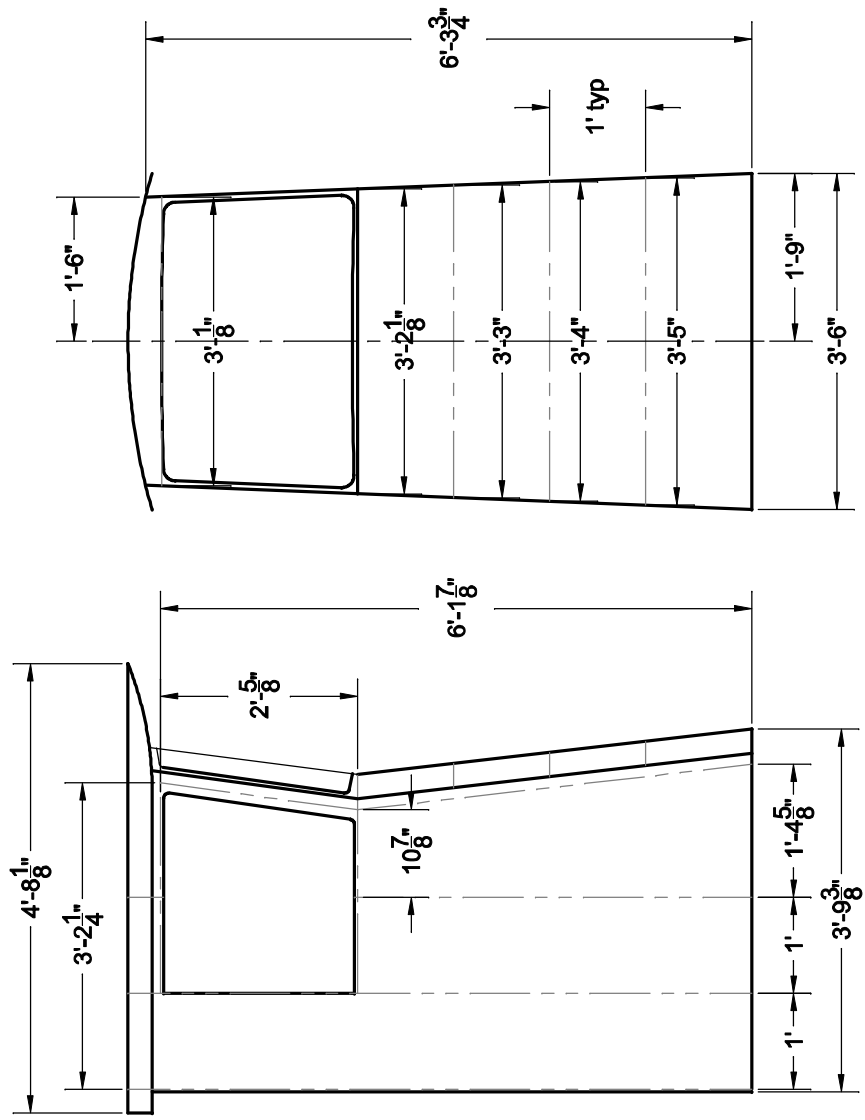
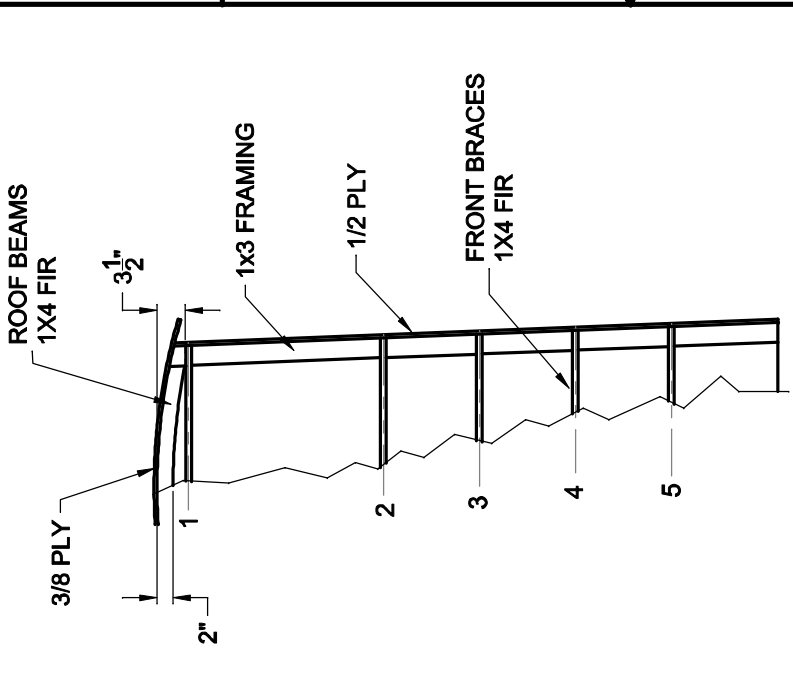

BRACE	LENGTH (L)
1	3' 1/8"
2	3' 2-1/8"
3	3' 3"
4	3' 4"
5	3' 5"

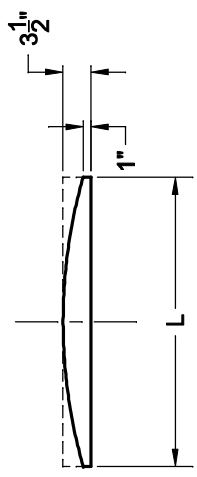

FRONT BRACES

Spira International, Inc.
Huntington Beach, California

PILOTHOUSE

DRAWN BY: J. SPIRA DATE: 09/12/08 DRAWING NO. PHSE02

SCALE: 1" = 1' SHEET OF